

Declaration of Rachel J. Watters on Authentication of Publication

I, Rachel J. Watters, am a librarian, and the Head of Resource Sharing for the General Library System, Memorial Library, located at 728 State Street, Madison, Wisconsin, 53706. Part of my job responsibilities include oversight of Wisconsin TechSearch (“WTS”), an interlibrary loan department at the University of Wisconsin-Madison. I have worked as a librarian at the University of Wisconsin library system since 1998, starting as a graduate student employee in the Kurt F. Wendt Engineering Library and WTS, then as a librarian in Interlibrary Loan at Memorial Library. I began professional employment at WTS in 2002 and became WTS Director in 2011. In 2019, I became of Head of Resource Sharing for UW-Madison’s General Library System. I have a master’s degree in Library and Information Studies from the University of Wisconsin-Madison. Through the course of my studies and employment, I have become well informed about the operations of the University of Wisconsin library system, which follows standard library practices.

This Declaration relates to the dates of receipt and availability of the following:

Chen, S.C. and Lee, K. (April 1998). A mixed-mode smart transducer interface for sensors and actuators. *Sound & Vibration*, 32(4), 24-27.

Standard operating procedures for materials at the University of Wisconsin-Madison Libraries. When an issue was received by the Library, it would be checked in, stamped with the date of receipt, added to library holdings records, and made available

Declaration of Rachel J. Watters on Authentication of Publication

to readers as soon after its arrival as possible. The procedure normally took a few days or at most 2 to 3 weeks.

Exhibit A to this Declaration is a true and accurate copy of the verso page with library date stamp of *Sound & Vibration* (April 1998), from the University of Wisconsin-Madison Library collection. Exhibit A also includes an excerpt of pages 24 to 27 of that issue, showing the article entitled *A mixed-mode smart transducer interface for sensors and actuators* (April 1998). Based on this information, the date stamp on the issue's verso page indicates *A mixed-mode smart transducer interface for sensors and actuators* (1998) was received by the Kurt F. Wendt Library, University of Wisconsin-Madison Libraries on May 28, 1998.

Based on the information in Exhibit A, it is clear that the issue was received by the library on or before May 28, 1998, catalogued and available to library patrons within a few days or at most 2 to 3 weeks after May 28, 1998.

Members of the interested public could locate the *Sound & Vibration* (April 1998) publication after it was cataloged by searching the public library catalog or requesting a search through WTS. The search could be done by title and/or subject key words. Members of the interested public could access the publication by locating it on the library's shelves or requesting it from WTS.

I declare that all statements made herein of my own knowledge are true and that all statements made on information and belief are believed to be true; and further that

Declaration of Rachel J. Watters on Authentication of Publication

these statements were made with the knowledge that willful false statements and the like so made are punishable by fine or imprisonment, or both, under Section 1001 of Title 18 of the United States Code.

Date: April 4, 2023

Memorial Library
728 State Street
Madison, Wisconsin 53706

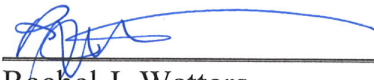

Rachel J. Watters
Head of Resource Sharing

Exhibit A

SOUND & VIBRATION

INSTRUMENTATION REFERENCE ISSUE

APRIL 1998

Data Acquisition Systems IEEE-P1451.4 Standard Instrumentation Buyer's Guide

S
S0705
V65



***** CAR-RT SORT ** C003
576 517 015 88 APR8
UNIV. OF WISCONSIN
K F WENDT LIBRARY
215 N RANDALL AVE
MADISON WI 53706-1605

00954

EDITOR AND PUBLISHER

Jack K. Mowry

ASSOCIATE EDITOR

George F. Lang

CONTRIBUTING EDITORS

Randall J. Allemang

Nelson L. Baxter

Clifford R. Bragdon

Malcolm J. Crocker

David J. Ewins

John L. Frarey

Gregg K. Hobbs

John S. Mitchell

Richard J. Peppin

Chris D. Powell

Mark C. Rodamaker

Larry H. Royster

Rajendra Singh

Strether Smith

Eric E. Ungar

Patrick L. Walter

Donald Wasserman

CIRCULATION MANAGER

Nancy Ormsby

NEWS EDITOR

Jennifer A. Baase

ART DIRECTOR

Gerald F. Garfield

MEMBER

BUSINESS PUBLICATIONS

AUDIT OF CIRCULATION



MEMBER

ASSOCIATION OF

BUSINESS PUBLISHERS



sound and vibration

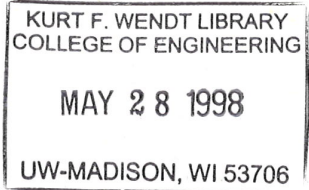

THE NOISE AND VIBRATION CONTROL MAGAZINE

*Noise and Vibration Control • Equipment Reliability
Structural Analysis • Dynamic Measurements
Dynamic Testing*

APRIL 1998

VOLUME 32/NUMBER 4

EDITORIAL

Some Things Change and Some Things Remain the Same! 5
Patrick L. Walter

FEATURES

**New Developments in Large-Scale
Dynamic Data Acquisition Systems 18**
*Strether Smith, Steve Katz, Bill Hollowell, Eric Olson, Al Brower,
Bob Franz and Scott Snyder*

**A Mixed-Mode Smart Transducer
Interface for Sensors and Actuators 24**
Steven C. Chen and Kang Lee

Dynamic Measurement Instrumentation Buyer's Guide 29

DEPARTMENTS

S&V News 1
S&V Observer 6
Our Authors 14
Professional Services 37
Reader-Service Index 38
Reader-Service Card 39

COVER

The cover photograph depicts IOtech's new WaveBook/516 portable PC-based data acquisition system being used in "Hummer" vehicle testing at AM General Corporation's testing facility in Livonia, MI. The WaveBook /516 provides 1-MHz speed data acquisition while maintaining 16-bit resolution. This performance accommodates multichannel data collection for test and measurement applications such as: vehicle noise and vibration testing which require high resolution. (*Photo courtesy of IOtech, Cleveland, OH.*)

SOUND AND VIBRATION (ISSN 0038-1810) is published monthly by Acoustical Publications, Inc., P.O. Box 40416, Bay Village, OH 44140. Periodicals postage paid at Cleveland, OH and additional mailing offices. POSTMASTER: Send address changes to SOUND AND VIBRATION, P.O. Box 40416, Bay Village, OH 44140. Copyright © 1998, Acoustical Publications, Inc., 27101 E. Oviatt Rd., P.O. Box 40416, Bay Village, OH 44140. Telephone: (440) 835-0101. FAX: (440) 835-9303. e-mail: sv@mindspring.com. All rights reserved. Permission to Photocopy: Where necessary, permission is granted by the copyright owner for libraries and others registered with the Copyright Clearance Center (CCC) to photocopy any article herein for the flat fee of \$2 per copy of the article. Payment should be sent directly to CCC, 27 Congress St., Salem, MA 01970. Permission for reproduction and copying, for other than personal or internal reference use, may be obtained from the publisher. ISSN 0038-1810/97 \$2.00. Subscriptions: SOUND AND VIBRATION is circulated without charge to qualified individuals in the United States who are concerned with noise and vibration control, equipment reliability, structural analysis, dynamic measurements, and dynamic testing. Qualified individuals perform the following functions: design engineering, testing and evaluation, management, research and development, consulting and engineering services, equipment reliability/PM/PdM, occupational safety and health, and other functions related to the fields served. Application for a free subscription may be made by filling out the card bound into each issue or by requesting a subscription application card from the publisher. Please allow one to three months for mailing of first issue. Subscription rates for unqualified U.S. subscribers and individuals outside of the United States are: Domestic - \$20 per year, Canada - \$25 U.S. per year. Other countries - \$60 U.S. per year (surface airlift mail). Single copy prices: U.S. - \$2, Canada - \$2.50, all others - \$5 U.S. (air mail). Subscription Correspondence: Address inquiries and requests to SOUND AND VIBRATION, P.O. Box 40416, Bay Village, OH 44140. Use subscription application form for address change and include address label from a recent issue. Please allow one to three months for address change.

A Mixed-Mode Smart Transducer Interface for Sensors and Actuators

Steven C. Chen, Aeptec Microsystems, Inc., Rockville, Maryland

Kang Lee, National Institute of Standards and Technology, Gaithersburg, Maryland

This article discusses some of the key issues of the proposed IEEE P1451.4 standard – the existing mixed-mode transducer communication schemes, the Transducer Electronic Data Sheet (TEDS) requirements, compatibility with legacy systems, and utilization of results of other P1451 developments to leverage existing and emerging sensor-networking technologies.

Today, the transducer industry produces and utilizes mainly analog transducers. Interfacing these transducers to measurement and control systems is a major and costly undertaking. While digital communication is the trend of the future, the issue of interfacing analog transducers with additional smart features to legacy systems should be addressed.

The test and measurement community requires transducers with built-in identification which also fulfill more common requirements: 2 wire system, small size, low cost, low power consumption, etc. The test and measurement community will be best served with a standardized transducer interface and a uniquely identifiable set of standardized protocols.

Due to the lack of such a standard, some transducer manufacturers have introduced various solutions but have seen limited acceptance. An independent and openly defined standard will reduce risk for potential users, transducer and system manufacturers, and system integrators. This will accelerate the emergence and acceptance of this technology. Therefore, the project, IEEE P1451.4, was established to develop a standard that allows analog transducers to communicate digital information (mixed-mode operation) for the purposes of self-identification and configuration.

The IEEE P1451 Working Groups have been working on a uniform approach for connecting sensors and actuators to communication networks, control systems and measurement systems. The P1451.1, 1451.2 and P1451.3 efforts focused on network-capable sensors and actuators with digital readings. The P1451.4 effort proposes a mixed-mode smart transducer communication protocol based on existing analog connections. It also specifies TEDS formats for interfacing analog transducers with additional smart features to the legacy systems. The proposed interface will be designed to be compatible with other P1451 network-capable transducer interfaces.

P1451.4 Proposed Standard

The proposed standard will define an interface for mixed-mode transducers (i.e., analog transducers with digital output for control and self-describing purposes) as part of the P1451 family of standards (see Figure 1). It will establish a standard that allows analog-output, mixed-mode transducers to communicate digital information with an IEEE P1451 compliant object. Both sensors and actuators are supported and the existence of the P1451.4 interface is invisible from the network viewpoint.

It is the intent that all of the standards in the IEEE 1451 family can be used either as stand-alone or with each other. For example, a 'black box' transducer with a P1451.1 object model combined with a P1451.4-compliant transducer is within the

ICP is a registered trademark of PCB Piezotronics, Inc.
MicroLAN is a registered trademark of Dallas Semiconductor, Inc.
LabVIEW is a registered trademark of National Instruments, Inc.
IBASIC is a registered trademark of Hewlett-Packard Company
DeltaTron is a registered trademark of Brüel & Kjær

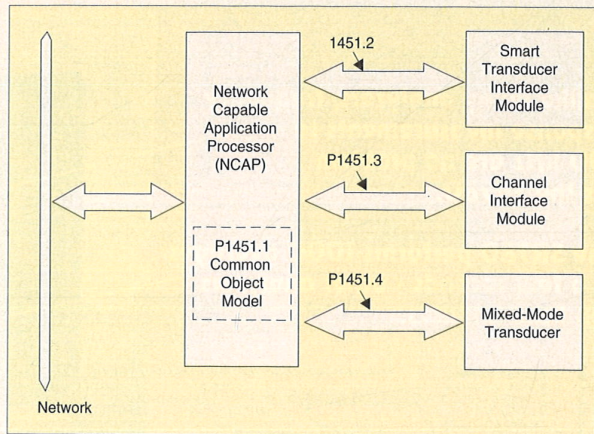

Figure 1. IEEE P1451 family relationship.

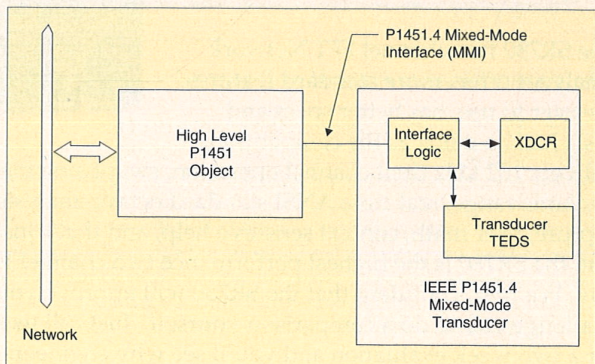

Figure 2. IEEE P1451.4 interface.

definition of the P1451 family specification. The IEEE P1451.4 interface is needed both to allow the use of existing analog transducer wiring and also for those demanding applications where it is not practical to physically include the Network Capable Application Processor (NCAP) with the transducer. Examples of the latter include very small transducers and very harsh operating environments.

Each P1451.4-compliant mixed-mode transducer would consist of at least one transducer and the interface logic required to control and transfer data across various existing analog interfaces (see Figure 2). The transducer TEDS will be minimized and defined such that it contains enough information to allow a higher level P1451 object to fill any gaps in its TEDS.

Scope. This P1451.4 Working Group will propose a standard that allows analog transducers to communicate digital information with an IEEE P1451 object. The standard will define the protocol and interface. It will also define the format of the transducer TEDS. The transducer TEDS will be based on the IEEE 1451.2 TEDS. The standard will not specify the transducer design, signal conditioning or the specific use of the TEDS.

Purpose. A standard is needed that allows analog transducers to communicate digital information for the purposes of self-identification and configuration. Due to the lack of a standard, some transducer manufacturers have introduced various solutions but have seen limited acceptance. An independent and

openly defined standard will reduce risk for potential users, transducer and system manufacturers and system integrators. This will accelerate the emergence and acceptance of this technology.

TEDS. The P1451.4 TEDS shall be compatible with the 1451.2 TEDS with the goal to minimize the size of nonvolatile memory. The key consideration for TEDS design are: relevant information that help the user, "plug-and-play" functionality, support for all transducers, openness for individual needs and compatibility to 1451.2. The P1451.4 TEDS shall include the following categories:

1. Identification Parameters
 - a. Manufacturer name
 - b. Model number
 - c. Series number
 - d. Revision number
 - e. Date code
2. Device Parameters
 - a. Sensor type
 - b. Sensitivity
 - c. Bandwidth
 - d. Units
3. Calibration Parameters
 - a. Last calibration date
 - b. Correction engine coefficients
4. Application Parameter
 - a. Channel identification
 - b. Channel grouping
 - c. Sensor location and orientation

The most recent proposed TEDS includes a 256-bit, non-human-readable compact-TEDS and additional human-readable TEDS. The compact-TEDS enables the minimum implementation of a P1451.4 TEDS for transducers which have limited memory or size. Table 1 indicates the latest proposal for the P1451.4 compact-TEDS which will include parameters, such as bandwidth, which are critical for higher bandwidth transducers.

Implementation. To take advantage of the results from the P1451 effort, P1451.4 will establish a standard that allows

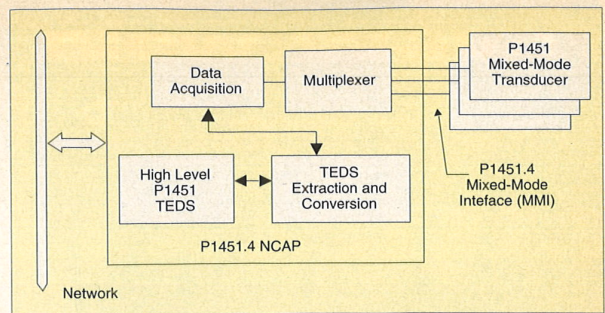

Figure 3. IEEE P1451.4 compatible NCAP.

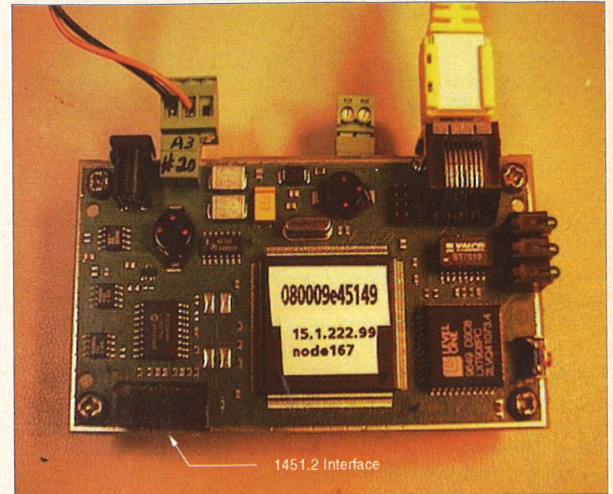

Figure 4. Ethernet-to-1451.2 NCAP created for a demonstration of concept (courtesy of Hewlett-Packard).

analog-output mixed-mode transducers to communicate digital information with a high-level IEEE P1451 object.

Table 1. Proposed IEEE P1451.4 Transducer Electronic Data Sheet (TEDS) measuring template formats.

Field Description	Type	Access	# of Bits	Bit Position	Example	Unit
ROM Part						
Manufacturer	Brüel & Kjær	RO-Manuf.	11	0	Brüel & Kjær	
Type number		RO-Manuf.	16	11	1234	
Version letter		RO-Manuf.	5	27	" "	
Version number		RO-Manuf.	7	32	0	
Serial number		RO-Manuf.	25	39	1234567	
E²-PROM Part						
CRC8 for the first 64+256 bits		R/W-all	8	0		
Selector of template descriptor	IEEE 1451.4	SelOfDescriptor	2	8	IEEE 1451.4	
Template identification	Accelerometer		8	10	Acceleration	m/s ²
Sensitivity @ F _{ref}		R/W-Cal.	16	18	100.0E-6	V/ms ²
F _{ref}		R/W-Cal.	8	34	10.0E+0	Hz
Calibration date		R/W-Cal.	16	42	July 18, 1997	
Transfer function approximation						
F _{hp} electrical	(n=0: section disabled)	R/W-Cal.	12	58	10.0E-3	Hz
F _{lp} electrical	(n=0: section disabled)	R/W-Cal.	12	70	100.0E+0	Hz
F _{mounted} resonance	(n=0: section disabled)	R/W-Cal.	9	82	100.0E+0	Hz
Mounted Q	(n=0: section disabled)	R/W-Cal.	8	91	300.0E-3	
Temperature coefficient	(n=0: section disabled)	R/W-Cal.	9	99	1.0E-6	
Sensitivity direction (x,y,z)		R/W-Cal.	2	108	x=0,y=1,z=2	
Measurement position ID (0...511)		R/W-user	8	110		
Selector of extended template descriptor	User	SelOfExtDescript	2	118	User	
User data		R/W-user	136	120		
Total number of predefined bits					184	
Total number of bits					320	

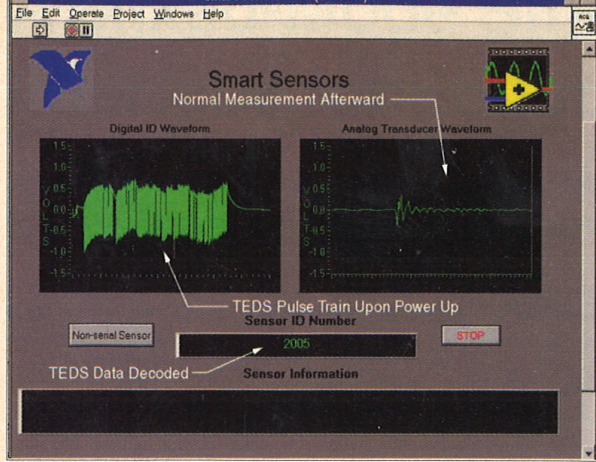

Figure 5. TEDS decoding with LabVIEW (courtesy of National Instruments).

One of the possible implementations is shown in Figure 3 – a multichannel P1451.4 NCAP, based on a 1451.2 NCAP, with optional multiplexer, data acquisition, logic or firmware for TEDS extraction and conversion, as well as high-level P1451 TEDS. Figure 4 shows a compatible 1451.2 NCAP created by Hewlett-Packard Co.* as a demonstration of concept.

Compatibility with Legacy Systems

P1451.4 transducers with TEDS will be compatible with legacy data acquisition systems by utilizing existing analog connections. Under normal operating condition, P1451.4 transducers will behave like traditional analog transducers. Upon power-up or interrogation, P1451.4 transducers will enter a digital communication mode.

Legacy systems can be updated to support P1451.4 transducers, as follows:

1. Hardware – Extra circuitry can be added at the front-end to control the P1451.4 transducers and to decode the TEDS. This will require modification of the legacy systems.
2. Patch Panel – A patch panel can be used between P1451.4 transducers and legacy systems to toggle power to the transducers or send out interrogation signals to activate the digital mode. It can also decode and upload the digital TEDS data to a controller. Additional hardware is necessary, but no modification of the legacy systems is required.
3. Firmware/Software – The embedded controller or the software in the legacy system can extract the TEDS data from the waveform memory after power up or interrogation. This solution requires no modification of legacy systems, nor additional hardware. Two previous demonstrations included a National Instruments LabVIEW® program with PC plug-in ADC (Analog to Digital Converter) cards (see Figure 5) and an IBASIC program with the HP35670A Dynamic Signal Analyzer.

Current Approaches

Several transducer manufacturers have supplied mixed-mode transducers with built-in intelligence for improvement such as self identification. These updated mixed-mode transducers utilize existing analog interfaces such as the ICP® and 4-20 mA current loop interfaces with or without an additional digital connection.

Several commercial mixed-mode smart transducers are available. Members of the P1451.4 working group have proposed two types of implementation. Brüel & Kjær has proposed a bi-directional, multi-drop communication scheme (see Figures 6,

*Certain commercial products are identified in this article in order to adequately describe the proposed standard. Such identification does not imply recommendation or endorsement by the National Institute of Standards and Technology.

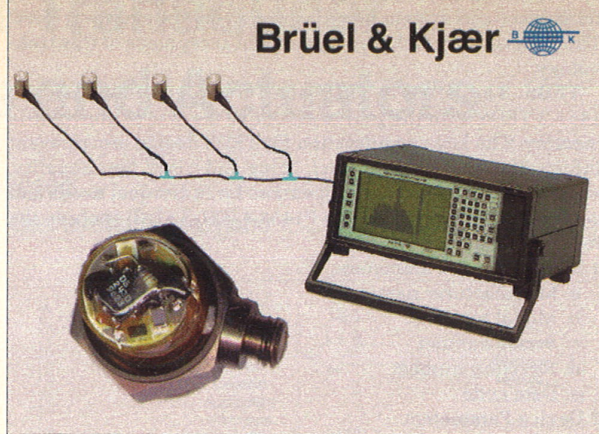

Figure 6. Example of possible multi-drop smart transducer (courtesy of Brüel & Kjær).

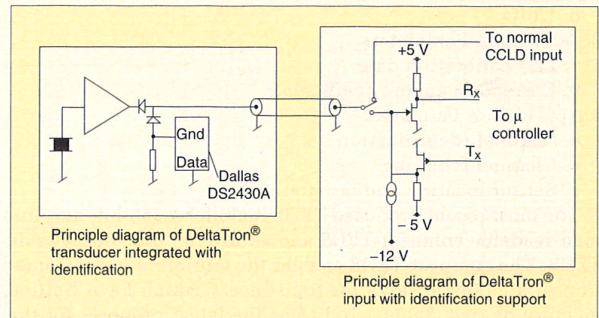

Figure 7. Example of current implementation (courtesy of Brüel & Kjær).

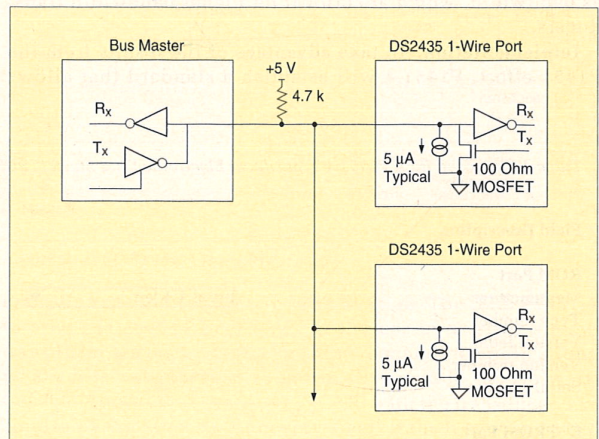

Figure 8. Coupling network between bus master (e.g., instrument) and 1-wire port (e.g., transducer). Proposed by Brüel & Kjær.

7 and 8). This proposal is based on standard MicroLAN® components from Dallas Semiconductor and the digital communication is activated by switching the normal (positive) supply current to a negative current. Other members have proposed point-to-point systems (such as shown in Figure 9). Digital communication is activated upon power-up (Kistler) or by a 2 mA drop of supply current for a predefined time period (Endevco and Wilcoxon).

Currently, the working group is very interested in the 1-wire MicroLAN® due to its one wire nature and commercially available components. Note in Figure 10 that the TEDS electronics does not increase the size of a modal accelerometer.

Future Development

The P1451.4 working group has formed a TEDS subgroup and the subgroup has achieved good progress. Hewlett-Packard and

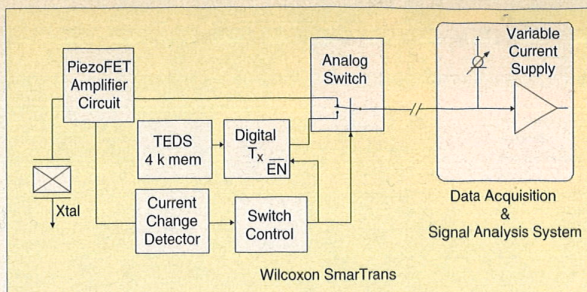

Figure 9. Example of current implementations (courtesy of Wilcoxon Research).

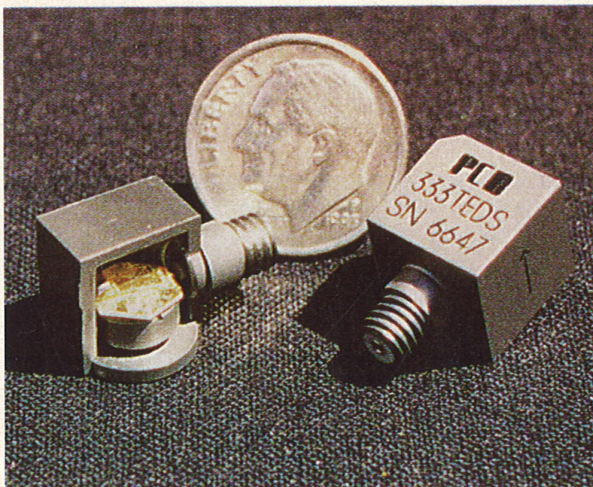

Figure 10. The challenge of implementing TEDS in a modal accelerometer (courtesy of The Modal Shop).

Kistler Instruments have agreed to provide licenses for their individual patents related to the P1451.4 working group effort. Dallas Semiconductors has also agreed to provide a license of their patents related to the 1-wire MicroLAN®.

Involvement by other companies with various sensing technologies will be highly welcome.

For more information on the P1451 working groups contact: Kang Lee, National Institute of Standards and Technology; Phone: 301-975-6602; e-mail: Kang.Lee@NIST.gov.

Acknowledgments

The authors would like to thank: Mark Buckner (Oak Ridge National Lab.), Jorgen Bække (B&K), Stan Woods (Hewlett-Packard) and all the members of the working group who have contributed to this work.

Bibliography

- Chen, S., Poland, J., Liang, Z., Lally, R., "Smart Transducers," Proceedings IMAC, 1993.
- Gierer, J., Grant, R., "Self Monitoring and Reporting Transducers," Proceedings Fourteenth Transducer Workshop, 1987.
- Talmadge, R., Appley, K., "Programmable Transducer Microchip Development," Proceedings Sensors Expo, 1990.
- Eller, E., "An Accelerometer with Internal Self-Test and Identification," Proceedings Sensors Expo West, 1990.
- Proceedings First IEEE/NIST SMART Sensor Interface Standard Workshop, Gaithersburg, MD, 1994.
- Bryzek, J., et al, "Common Communication Interface for Networked Smart Sensors and Actuators," *SENSORS*, pp. 14-23, September, 1995.
- Brendel, A., "Sensor Stores Calibration Data in Nonvolatile ROM," *Test & Measurement*, June 1996.
- West, R., "Automatic Calibration of Strain Gauges," *SENSORS*, pp 44-46, July 1995.
- Gen-kuong, F., and Johnson, R., "Accelerometer for High Frequency, Low Noise Application, with Self-Test/ID Feature," 1990 Proceedings of Institute of Environmental Sciences (IES).
- van der Waal, E., Droinet, Y., Coransson, S., Tidy, S., "A Low Cost, High Performance Mixed Signal ASIC for the Calibration of Piezo-Resistive Sensors," Sensors Expo West Proceedings, 1996. SIV

New Wave of Products from Ono Sokki

CF-1200 Hand-Held

- Built in sensor power supply
- Time, spectrum and overall display
- AC/DC Battery operation
- PCMCIA V 2.0 IC memory and data storage
- Lightweight (710g) with backlit LCD display

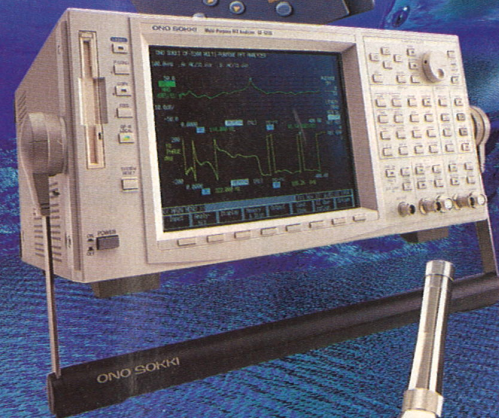
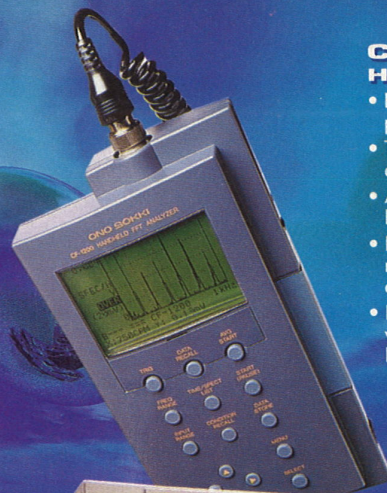

CF-5200 2-Ch FFT

- E-Z Operation
- 9.4" Color Display
- DOS Compatible 3.5" floppy disk
- Built-in printer
- 25-1,600 lines
- Zoom & 32kHz realtime
- Order tracking
- Realtime octave
- GP-IB & Centronics printer interface

LA-5110 Type I Sound Level Meter/RTA

- Five measurements made in two weightings simultaneously
- AC/DC and RS-232 Outputs
- 1/1 and 1/3 Realtime Analysis (Option)



ONO SOKKI TECHNOLOGY INC.

2171 Executive Dr., Ste. 400 Addison, IL 60101 • 800-922-7174

CF-1200, Circle 121 CF-5200, Circle 122 LA-5110, Circle 123