

UNITED STATES PATENT AND TRADEMARK OFFICE

BEFORE THE PATENT TRIAL AND APPEAL BOARD

META PLATFORMS, INC.,
Petitioner,

v.

THALES VISIONIX, INC.,
Patent Owner.

IPR2022-01304
Patent 6,922,632 B2

Before WILLIAM V. SAINDON, HYUN J. JUNG, and
JASON W. MELVIN, *Administrative Patent Judges*.

JUNG, *Administrative Patent Judge*.

DECISION
Granting Institution of *Inter Partes* Review
35 U.S.C. § 314

I. INTRODUCTION

A. *Background and Summary*

Meta Platforms, Inc. (“Petitioner”) filed a Petition (Paper 1, “Pet.”) requesting institution of an *inter partes* review of claims 1–9, 11–29, and 66–69 of U.S. Patent No. 6,922,632 B2 (Ex. 1001, “the ’632 patent”). Thales Visionix, Inc. (“Patent Owner”) filed a Preliminary Response. Paper 8 (“Prelim. Resp.”). With our authorization, the parties filed additional briefs directed solely to the issue of our discretion under 35 U.S.C. § 314(a). Papers 9, 10.

Under 35 U.S.C. § 314, an *inter partes* review may not be instituted “unless . . . there is a reasonable likelihood that the petitioner would prevail with respect to at least 1 of the claims challenged in the petition.” Upon consideration of the Petition and for the reasons explained below, we determine that Petitioner has shown a reasonable likelihood of prevailing with respect to at least one of the challenged claims.

Thus, we institute an *inter partes* review of claims 1–9, 11–29, and 66–69 of the ’632 patent on all presented challenges. *SAS Inst. Inc. v. Iancu*, 138 S. Ct. 1348, 1359–60 (2018).

B. *Real Parties in Interest*

Petitioner identifies Meta Platforms, Inc. and Meta Platforms Technologies, LLC as real parties in interest. Pet. 1. Patent Owner identifies Thales Visionix, Inc. and Gentex Corporation as real parties in interest. Paper 4, 1.

C. Related Matters

The parties identify *Gentex Corp. v. Meta Platforms, Inc.*, 4:22-cv-03892 (N.D. Cal.) as a related matter.¹ Pet. 1–2; Paper 4, 1. Patent Owner additionally identifies as related matters IPR2022-01305 that also challenges the same patent and IPR2022-01308 that challenges a related patent. Paper 4, 1–2.

We instituted an *inter partes* review of claims 30–36, 44, 45, 47–55, and 57–61 of the '632 patent in IPR2022-01305. *Meta Platforms, Inc. v. Thales Visionix, Inc.*, IPR2022-01305, Paper 12 (PTAB Mar. 13, 2023) (Decision Granting Institution).

D. The '632 Patent (Ex. 1001)

The '632 patent issued on July 26, 2005 from an application filed on August 11, 2003 and claims priority to a provisional application filed on August 9, 2002. Ex. 1001, codes (22), (45), (60). The '632 patent “relates to tracking, navigation, pose estimation, localization, auto-calibration, scene modeling, structure-from-motion and/or map-building based on sensor inputs.” *Id.* at 1:12–15. Reproduced below is Figure 1 of the '632 patent.

¹ The case was originally filed in the U.S. District Court for the Western District of Texas (No. 6:21-cv-00755-ADA) and was subsequently transferred to the U.S. District Court for the Northern District of California. Pet. 2. The parties incorrectly identify the case number in the Northern District of California as “5:22-cv-03892.” *Compare* Pet. 2; Paper 4 (Patent Owner’s Mandatory Notices), 1, *with* Ex. 2002 (Joint Order Regarding Claim Construction and Discovery).

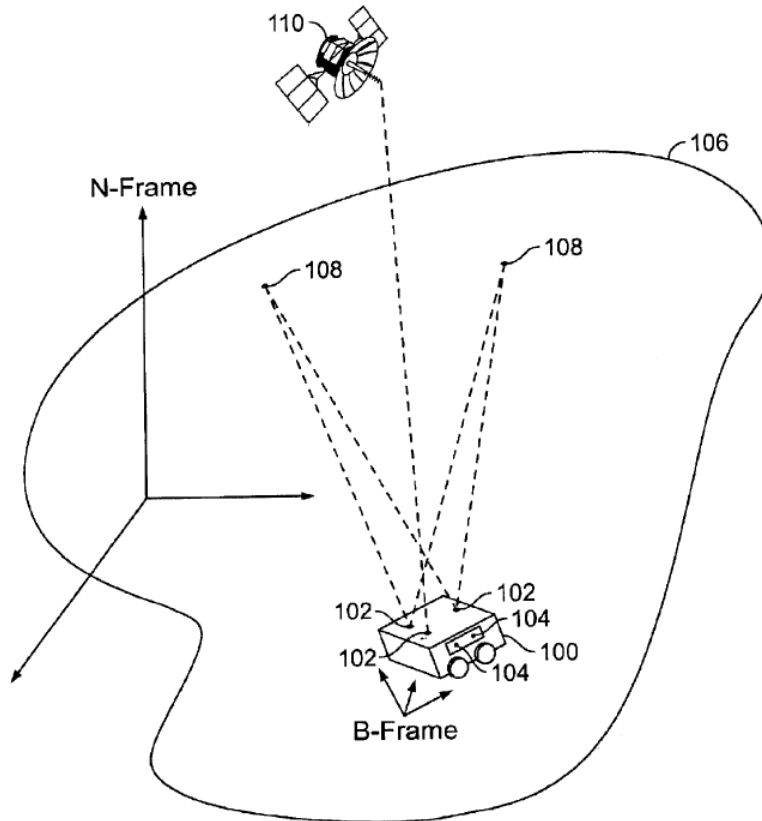

FIG. 1

Figure 1 “shows a vehicle navigating an environment.” Ex. 1001, 11:48. Navigation system 90 (shown in Figure 2 reproduced below) tracks vehicle 100 in environment 106, in particular “the position and the orientation (together referred to as the 6-dimensional ‘pose’) of vehicle 100 based on both inertial measurements as well as sensor measurements between sensing devices or targets in the vehicle 100 and sensing devices or targets that are fixed in the environment 106.” *Id.* at 12:3–4, 12:11–16.

Sensors and targets fixed to vehicle 100 or environment 106 are collectively referred to as pose sensing elements (“PSE”). Ex. 1001, 13:6–8. The ’632 patent states that “[f]or an ‘inside-out’ measurement, the sensor is attached to the vehicle and the target is fixed in the environment,” and “[f]or an ‘outside-in’ measurement, a sensor fixed in the environment observes a

target fixed to the moving vehicle.” *Id.* at 14:47–51. Reproduced below is Figure 2 of the ’632 patent.

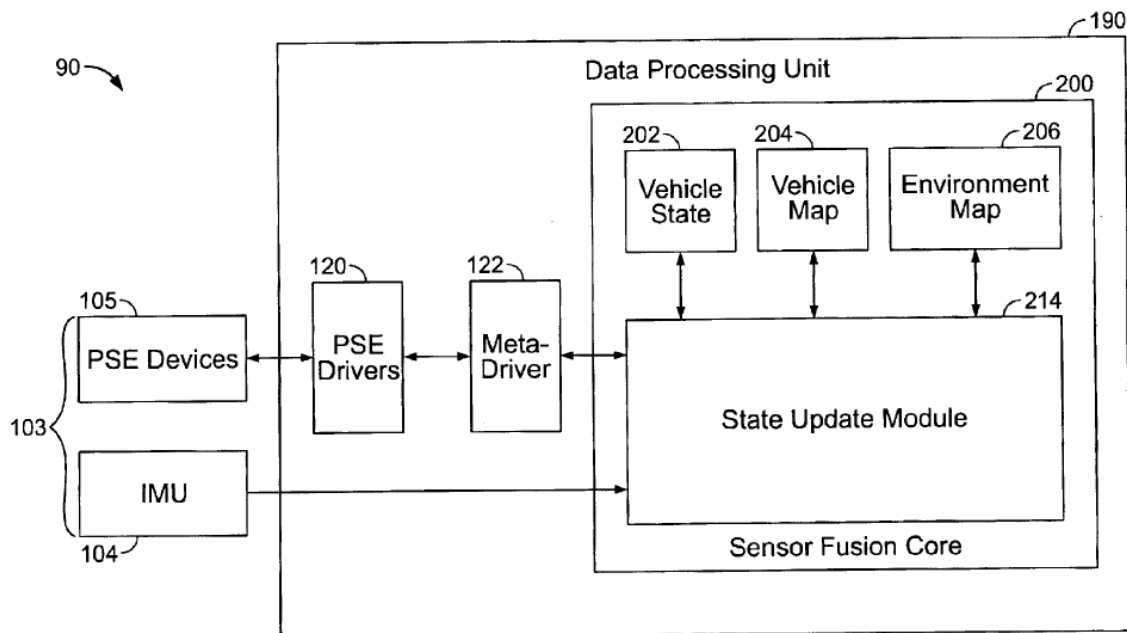

FIG. 2

Figure 2 is a block diagram of a navigation system. Ex. 1001, 11:49. Navigation system 90 includes sensors 103 and data processing unit 190. *Id.* at 12:5–7. Sensors 103 include PSE devices 105 and inertial measurement unit (“IMU”) 104. *Id.* at 12:45–48.

According to the ’632 patent, “a wide variety of sensors and targets may be used” because “[n]avigation system 90 is modularized and configurable such that different sensors and targets can be selected for a particular vehicle without necessarily having to re-implement and re-test the implementation of the navigation system.” Ex. 1001, 13:32–37. The ’632 patent “provides a ‘plug and track’ capability in which sensors and targets and their associated software drivers can be ‘plugged’ into the navigation system 90.” *Id.* at 13:37–40.

Explore Litigation Insights

Docket Alarm provides insights to develop a more informed litigation strategy and the peace of mind of knowing you're on top of things.

Real-Time Litigation Alerts



Keep your litigation team up-to-date with **real-time alerts** and advanced team management tools built for the enterprise, all while greatly reducing PACER spend.

Our comprehensive service means we can handle Federal, State, and Administrative courts across the country.

Advanced Docket Research



With over 230 million records, Docket Alarm's cloud-native docket research platform finds what other services can't. Coverage includes Federal, State, plus PTAB, TTAB, ITC and NLRB decisions, all in one place.

Identify arguments that have been successful in the past with full text, pinpoint searching. Link to case law cited within any court document via Fastcase.

Analytics At Your Fingertips



Learn what happened the last time a particular judge, opposing counsel or company faced cases similar to yours.

Advanced out-of-the-box PTAB and TTAB analytics are always at your fingertips.

API

Docket Alarm offers a powerful API (application programming interface) to developers that want to integrate case filings into their apps.

LAW FIRMS

Build custom dashboards for your attorneys and clients with live data direct from the court.

Automate many repetitive legal tasks like conflict checks, document management, and marketing.

FINANCIAL INSTITUTIONS

Litigation and bankruptcy checks for companies and debtors.

E-DISCOVERY AND LEGAL VENDORS

Sync your system to PACER to automate legal marketing.