

T-1 3/4 (5mm)

HLMP-D150A

Red Diffused

HLMP-D155A

Red Clear with Standoff

T-100 (3mm)

HLMP-K150

Red Diffused

HLMP-K155

Red Clear

PACKAGE DIMENSIONS

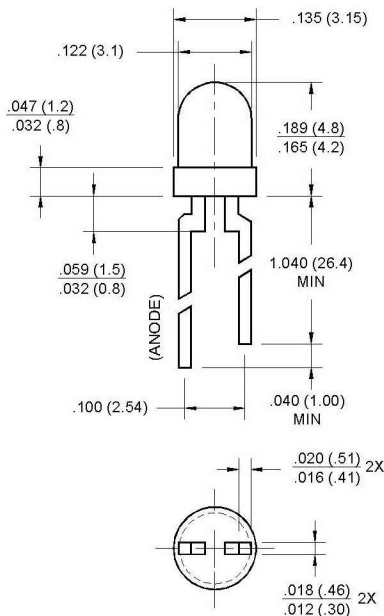

HLMP-K150/K155

FEATURES

- Wide Viewing Angle
- Deep Red Color

DESCRIPTION

Exceptional light output typifies these devices and provides for their use over a broad range of drive currents. The LED material is based on double heterojunction (DH) AlGaAs/GaAs technology.

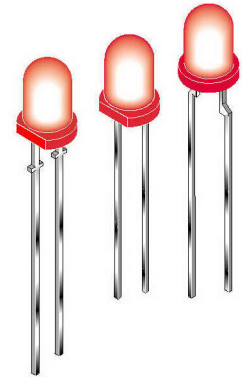

NOTES:

1. ALL DIMENSIONS ARE IN INCHES (mm).
2. TOLERANCE ARE $\pm .010$ " UNLESS OTHERWISE SPECIFIED.
3. AN EPOXY MENISCUS MAY EXTEND ABOUT .040" (1 mm) DOWN THE LEADS.

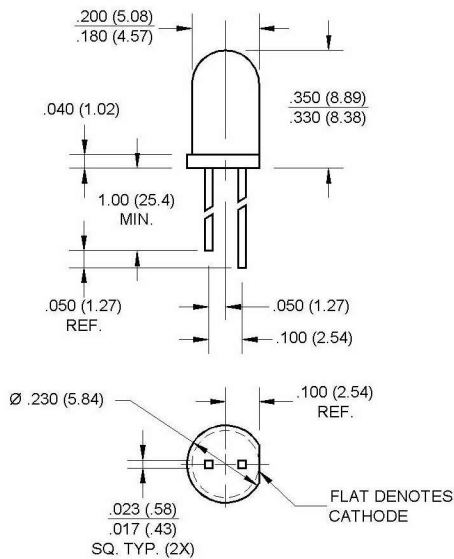

HLMP-D150A

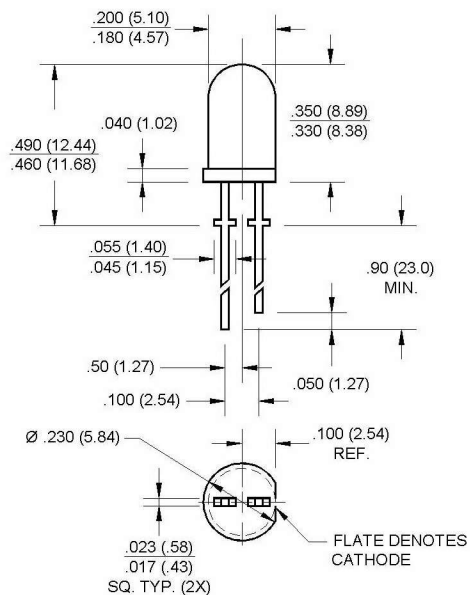

HLMP-D155A

ABSOLUTE MAXIMUM RATING (T_A =25°C)

Parameter	RED	UNITS
Power Dissipation	87	mW
Peak Forward Current (f=1kHz, DF=10%)	300	mA
Continuous DC Forward Current	30	mA
Lead Soldering Time at 260° C	5	sec
Operating Temperature	-20 to +100	°C
Storage Temperature	-55 to +100	°C

ELECTRICAL / OPTICAL CHARACTERISTICS (T_A =25°C)

Parameter	HLMP-K150	HLMP-K155	HLMP-D150A	HLMP-D155A	Condition
Luminous Intensity (mcd)					I _F = 1mA
Minimum	1.2	2.0	1.2	3.0	
Typical	2.0	3.0	3.0	10.0	
Forward Voltage (V)					I _F = 1mA
Maximum	1.8	1.8	1.8	1.8	
Typical	1.6	1.6	1.6	1.6	
Peak Wavelength (nm)	660	660	660	660	I _F = 1mA
Spectral Line Half Width	20	20	20	20	I _F = 1mA
Reverse Voltage (V)	5	5	5	5	I _R = 100µA
Viewing Angle (°)	60	45	65	24	I _F = 1mA

TYPICAL PERFORMANCE CURVES (T_A = 25°C)

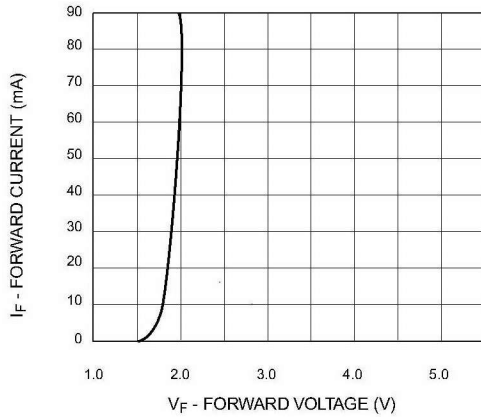

Fig. 1 Forward Current vs. Forward Voltage

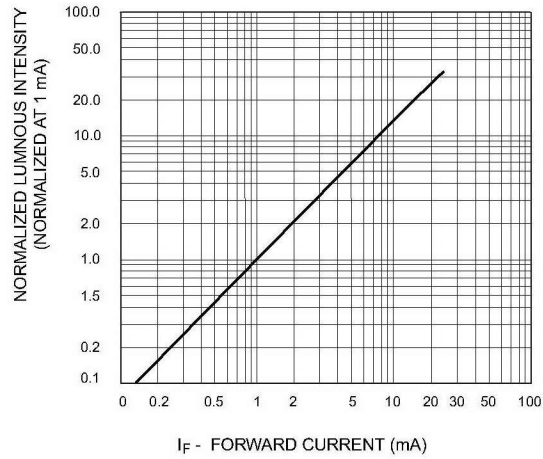

Fig. 2 Relative Luminous Intensity vs. DC Forward Current

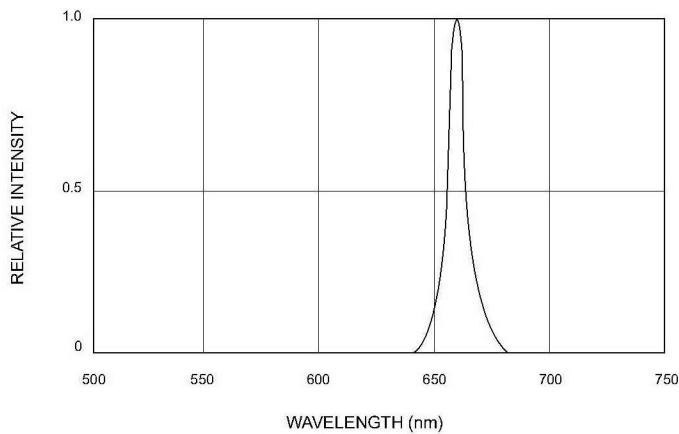

Fig. 3 Relative Intensity vs. Peak Wavelength

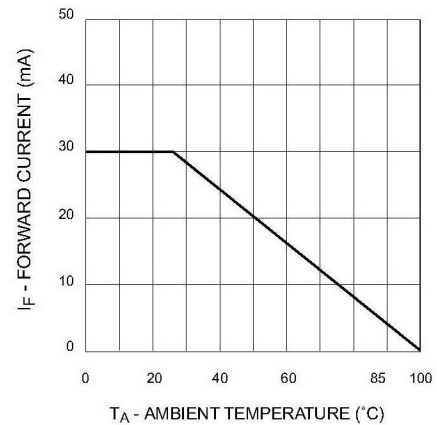
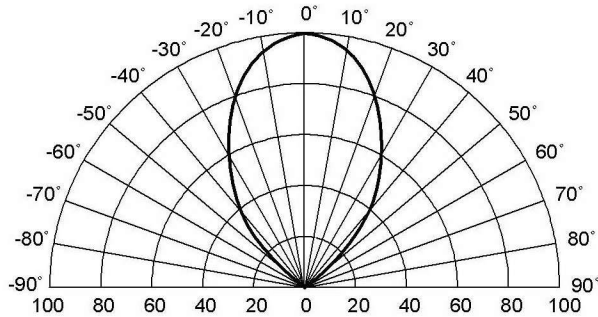

Fig. 4 Current Derating Curve

TYPICAL PERFORMANCE CURVES ($T_A = 25^\circ\text{C}$)



REL. LUMINOUS INTENSITY (%)

Fig. 5A Radiation Diagram (HLMP-D150A)

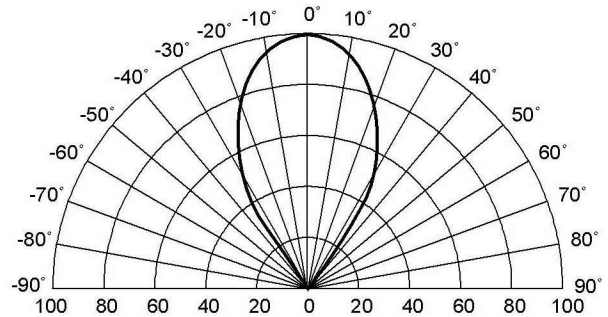

REL. LUMINOUS INTENSITY (%)

Fig. 5B Radiation Diagram (HLMP-K150)

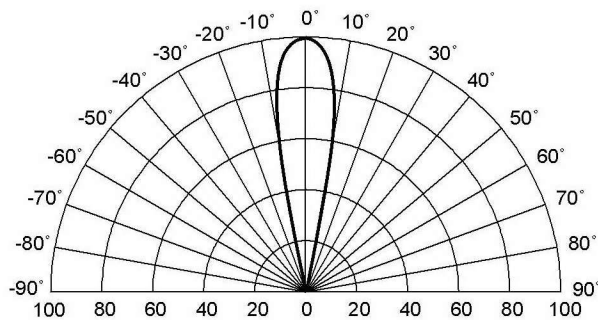

REL. LUMINOUS INTENSITY (%)

Fig. 5C Radiation Diagram (HLMP-D155A)

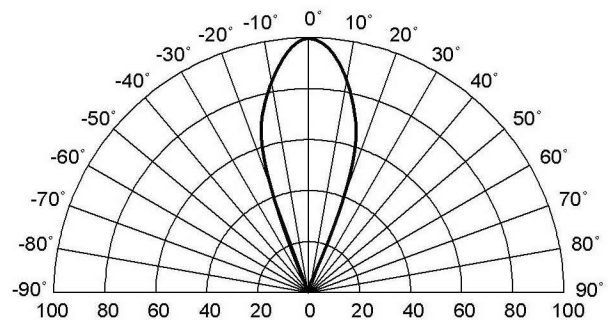

REL. LUMINOUS INTENSITY (%)

Fig. 5D Radiation Diagram (HLMP-K155)

DISCLAIMER

FAIRCHILD SEMICONDUCTOR RESERVES THE THE RIGHT TO MAKE CHANGES WITHOUT FURTHER NOTICE TO ANY PRODUCTS HEREIN TO IMPROVE RELIABILITY, FUNCTION OR DESIGN. FAIRCHILD DOES NOT ASSUME ANY LIABILITY ARISING OUT OF THE APPLICATION OR USE OF ANY PRODUCT OR CIRCUIT DESCRIBED HEREIN; NEITHER DOES IT CONVEY ANY LICENSE UNDER ITS PATENT RIGHTS, NOR THE RIGHTS OF OTHERS.

LIFE SUPPORT POLICY

FAIRCHILD'S PRODUCTS ARE NOT AUTHORIZED FOR USE AS CRITICAL COMPONENTS IN LIFE SUPPORT DEVICES OR SYSTEMS WITHOUT THE EXPRESS WRITTEN APPROVAL OF THE PRESIDENT OF FAIRCHILD SEMICONDUCTOR CORPORATION. As used herein:

1. Life support devices or systems are devices or systems which, (a) are intended for surgical implant into the body, or (b) support or sustain life, and (c) whose failure to perform when properly used in accordance with instructions for use provided in labeling, can be reasonably expected to result in a significant injury of the user.
2. A critical component in any component of a life support device or system whose failure to perform can be reasonably expected to cause the failure of the life support device or system, or to affect its safety or effectiveness.