



# Data Sheet

## Peltier effect heat pumps

RS stock numbers 618-724, 618-730

A range of semi-conductor thermoelectric devices working on the Peltier effect. When supplied with a suitable electric current they can either cool or heat. When subjected to an externally applied temperature gradient these devices will generate a small amount of electrical power.

Available in three sizes the larger devices can be used for cooling or controlling the temperature of sub-assemblies.

### Introduction to the Peltier effect

In 1834 Jean C. A. Peltier discovered that the passage of an electric current through the junction of two dissimilar conductors can either cool or heat this junction depending on the direction of current. Heat generation or absorption rates are proportional to the magnitude of the current and also the temperature of the junction.

Practical Peltier Effect Heat Pumps consist of many such couples connected electrically in series and thermally in parallel.

Figure 1 A single couple

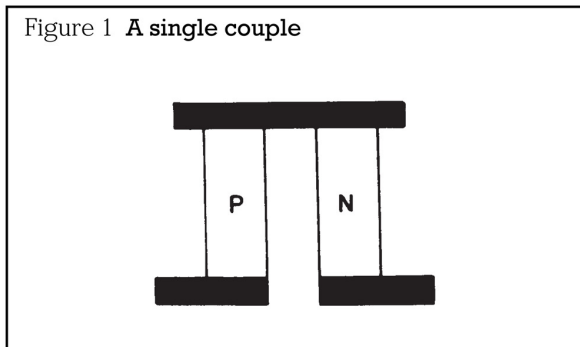

Semiconductors doped both p and n type form the elements of the couple and are soldered to copper connecting strips. Ceramic faceplates electrically insulate these connecting strips from external surfaces. The semiconductor material used is bismuth telluride as this shows the most pronounced effect at moderate operating temperatures.

### Features

- Solid state, long term stability
- Capable of heating or cooling - dependent on current flow
- Generates no acoustic noise
- Capable of generating power.

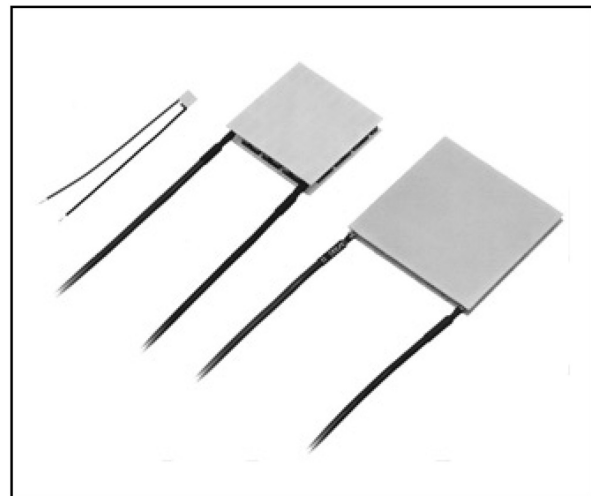
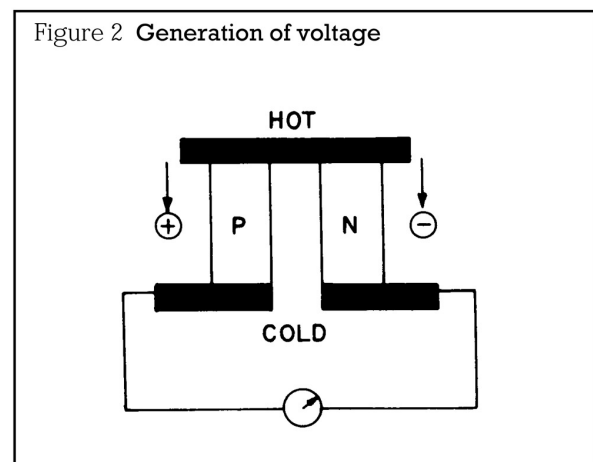
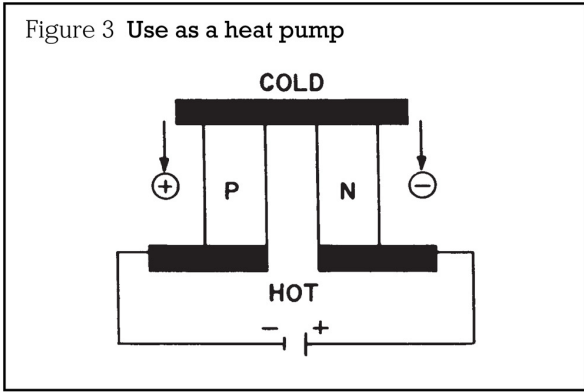

Figure 2 Generation of voltage



At open circuit a temperature gradient maintained across the device creates a potential across its terminals proportional to the temperature difference. If the temperature difference is maintained, and if the device is connected to an electrical load power is generated.



If, instead the device is connected to a dc source, heat will be absorbed at one end of the device, cooling it, while heat is rejected at the other end, where the temperature rises. Reversing the current reverses the flow of heat. Therefore the module can generate electric power or, depending on how it is connected to external circuitry, heat or cool an object.

A common misconception is that the Peltier device somehow absorbs heat and carries it away, perhaps with the electric current. This is simply not true. The device only transfers or pumps heat from one of its sides to the opposite side. At the hot side, the heat must be removed through the use of a heat sink or by some other means. It is important to realise that the heat delivered to the hot side of the device includes the pumped heat plus the electrical power dissipated within the device.

**Peltier 18.8W (RS stock no 618-724) and 68.8W (RS stock no 618-730) modules**

**Electrical characteristics**

at hot side temperature  $T_h = 25^\circ\text{C}$

Parameter	RS stock no 618-724	RS stock no 618-730
Maximum temperature difference ( $\Delta T$ )	70°C	65°C
Maximum current	9A	8.5A
Maximum voltage	3.75	15.4
Heat pumping capacity ( $Q_c$ )	18.8W	68.8W
Operating temperature range	-150°C to +110°C	

**Specifications**

Universal multipliers			Dimensions		
N No. of Couples	G Geometry factor	G x N	A (mm)	B (mm)	C (mm)
31 RS stock no (618-724)	0.18	5.58	30	30	5.6
127 RS stock no (618-730)	0.17	21.60	40	40	3.3

Larger Peltier devices of 18.8W and 68.8W ratings. The 18.8W module takes a maximum current of 9A with the 68.8W device taking 8.5A. They are both suitable for cooling sub-assemblies.

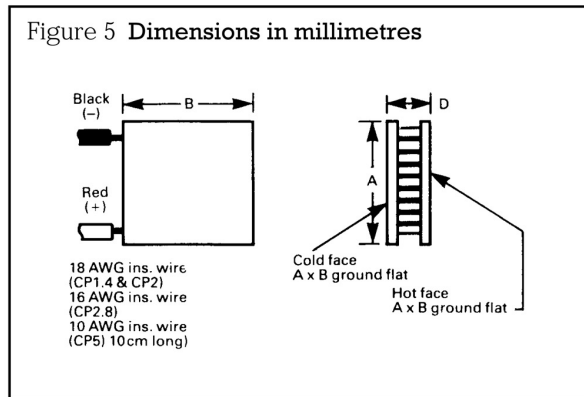

## Using Peltier devices

When trying to determine the heat pumping capacity required, two factors must be considered; active heating elements and heat leak.

Active heating elements are any components which have a power consumption. All of this power consumption (input power) will eventually be converted to heat and should be considered as heat load.

An object that is held at a temperature below ambient will draw heat from the surroundings onto its cold surface. The results of this additional heat is that a cooled object which is not insulated will not be able to maintain temperatures as low as one which has insulation. This additional heat load requirement is called the heat leak. Three main factors affect the magnitude of the heat leak. These are:

1. The temperature difference between ambient and the cooled device.
2. The surface area of the cooled device.
3. The amount of insulation used. It is advantageous to thermally insulate the device being cooled in order to reduce the heat leak to a minimum.

There are other sources of heat leak such as conduction heat from electrical wires or heat leak from the heat sink back to the cold plate of the Peltier device. Hence precise calculation of heat leak is difficult and it may be best determined empirically.

The total heat pumping capacity required is the sum of the active heat load and the heat leak.

## Choosing the proper heat sink

Once the required heat pumping capacity has been determined the next step is choosing the proper heat sink. A Peltier device is not a sponge which absorbs heat, rather, it is a heat pump. The heat which is pumped out of the cold surface is deposited on the hot side of the module. This heat must be dissipated in some way. If it is not the hot side of the device will heat up the point where it will stop functioning as a cooling device and actually begin to heat the cold surface.

From fundamentals, a heat sink must be maintained at a temperature higher than ambient to transfer heat from its surface out into the surroundings. The higher the heat sink temperature above the ambient temperature the more heat can be transferred out of the heat sink. This points to choosing a heat sink which will get as hot as possible. However, reference to the performance curves shows that as the  $\Delta T$  across the module becomes larger (as a result of the increased hot side temperature) the heat pumping capacity and the coefficient of performance (COP) both decrease. Considering both these phenomena a heat sink which rises to a temperature between 5 and 15°C above ambient is a practical choice.

Figure 6 Coefficient of performance vs current

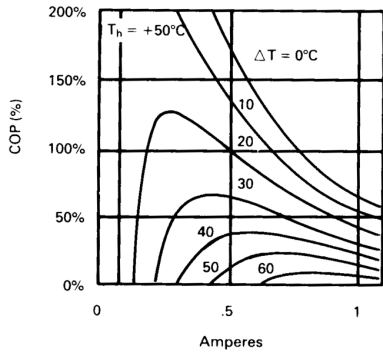

How to use universal performance graphs

Example:

a device dissipates 31 watts of power. It is desired to maintain the device at a constant temperature of  $+5^\circ\text{C}$ , the ambient temperature being  $+35^\circ$  (ie.  $T_c = +5^\circ\text{C}$ ,  $T_h = +35^\circ\text{C}$ ). To select the appropriate module, approach with the following method:

$$1. \Delta T = T_h - T_c = +35^\circ - 5^\circ = +30^\circ\text{C}.$$

Choose operating current (typically from 30G to 40G) at 35G (equals  $35/50 = 70\%$  of  $I_{max}$ ).

2. From  $T_h = +35^\circ\text{C}$  graph ( $\Delta T = +30^\circ$ ,  $I = 35\text{G}$ ), obtain  $Q_c / G \times N = 1.65$ ; Then  $G \times N = Q_c / 1.65 = 31 / 1.65 = 18.8$ .

3. Choose module with  $G \times N \geq 18.8$

This implies that the 68.8W (RS stock no 618-730) module is the most suitable for the application.

Figure 7 Hot side mounted to heat sink

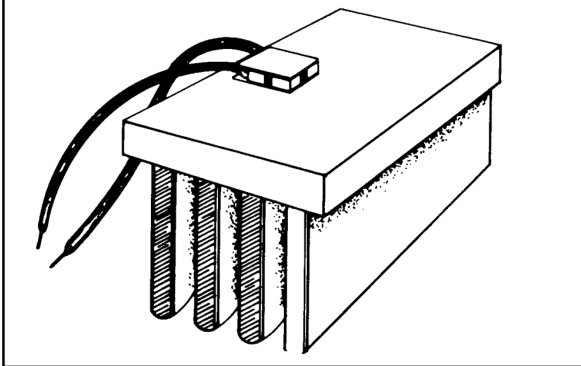
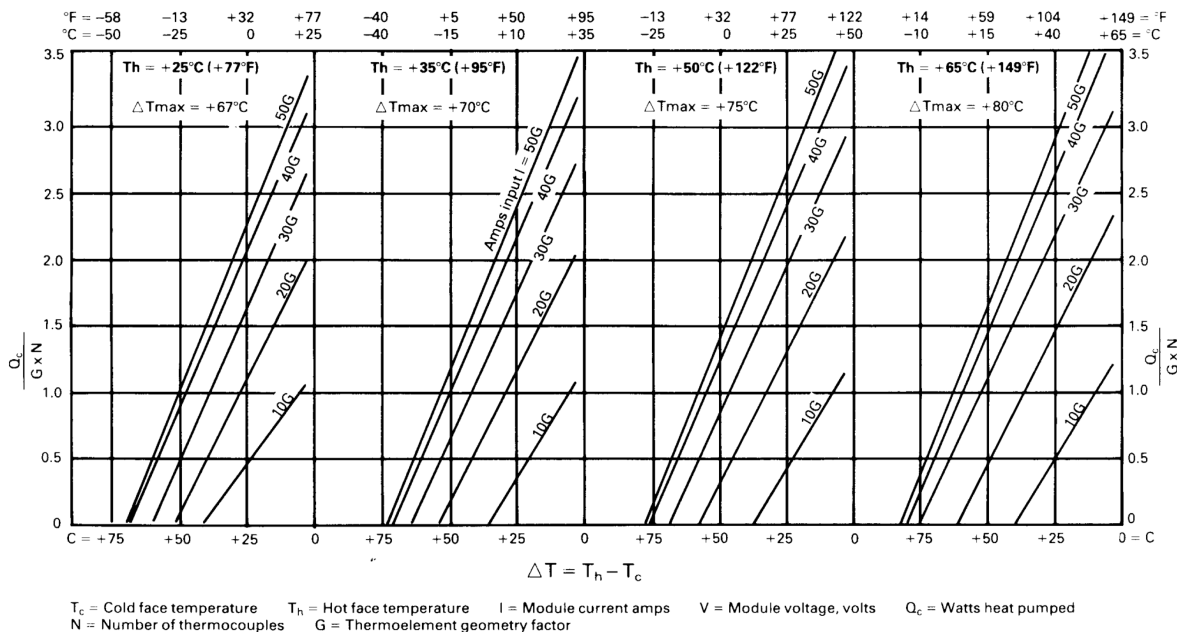

Figure 8 Universal performance graphs



### Installation of Peltier devices

Peltier devices are only as strong as the semiconductor materials used in their fabrication and thus may be damaged by the application of excessive stress. Modules should never be designed as a mechanical supporting member of an assembly.

Two mounting methods are recommended with the clamping method being generally preferred. Epoxy bonding should not be used when operation in the vacuum is required.

### Clamping method

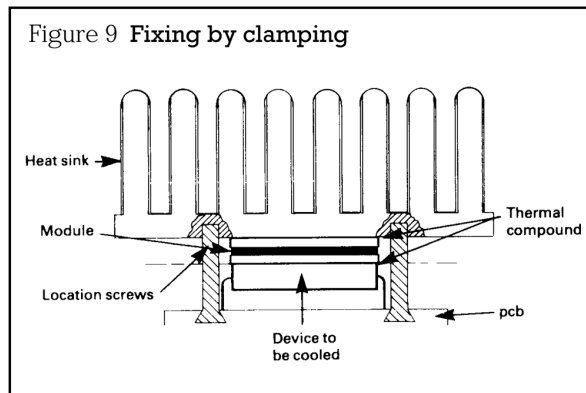

1. The mounting surfaces should be smooth to within  $\pm 0.001$  in.
2. Clean the module and mounting surfaces to remove any burrs, grit, etc.
3. Coat the module hot side with a thin film of heatsink compound and place the module on the heat sink. Applying firm but even downward pressure, rock the module from side to side until a slight resistance is felt and excess heatsink compound is squeezed out.
4. Coat the cold side of the module with a thin film of heatsink compound. Place the object to be cooled in contact with the module and rock the object slightly from side to side to squeeze out excess thermal grease.
5. Both the object to be cooled and heat sink together using either stainless steel screws with spring washers or nylon screws. To ensure even pressure across the module surfaces, tighten all screws finger tight and then continue tightening in an alternate or diagonal pattern starting with the centre screws (if any) first. Maximum recommended compression loading is 15 pounds per square inch of module surface. **Do not over tighten.**

### Epoxy bonding method

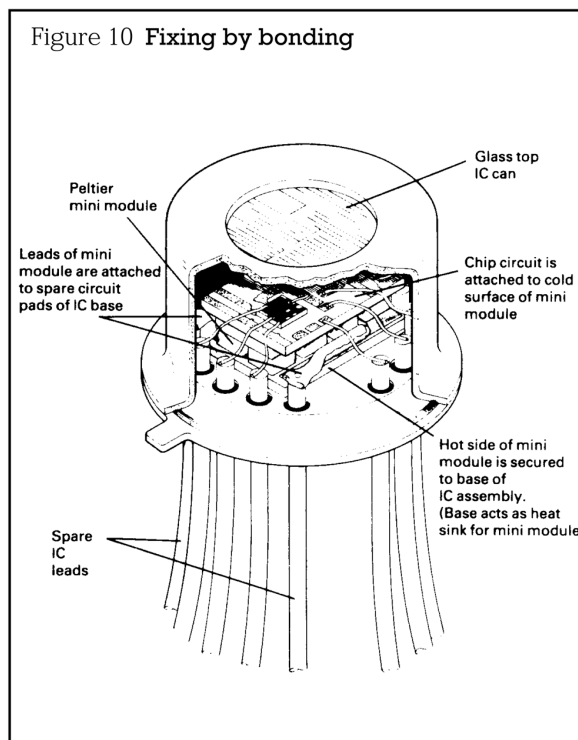

1. The mounting surfaces should be smooth, flat and free from grease or burrs.
2. Coat the module hot side with a thin layer of silver loaded epoxy.
3. Place the module on the heat sink and rock slightly to squeeze out excess epoxy.
4. Weight or lightly clamp the module to hold it in place until the epoxy has cured.

### Power supply considerations

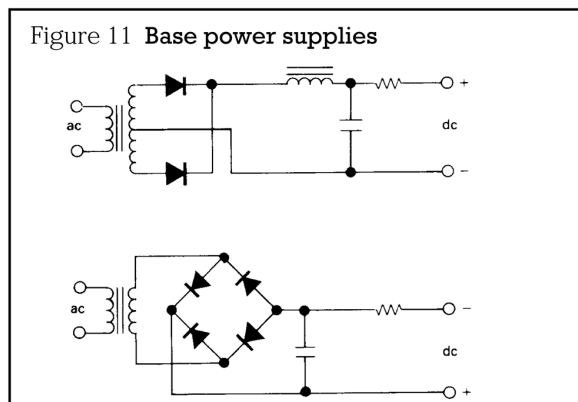

Peltier devices operate from direct current and the power requirements are usually not stringent or precise. For most applications, unregulated dc power with a ripple content of 10% or less is satisfactory and it is possible that higher levels of ripple can be tolerated for certain non-critical applications. However, because

# Explore Litigation Insights

Docket Alarm provides insights to develop a more informed litigation strategy and the peace of mind of knowing you're on top of things.

## Real-Time Litigation Alerts



Keep your litigation team up-to-date with **real-time alerts** and advanced team management tools built for the enterprise, all while greatly reducing PACER spend.

Our comprehensive service means we can handle Federal, State, and Administrative courts across the country.

## Advanced Docket Research



With over 230 million records, Docket Alarm's cloud-native docket research platform finds what other services can't. Coverage includes Federal, State, plus PTAB, TTAB, ITC and NLRB decisions, all in one place.

Identify arguments that have been successful in the past with full text, pinpoint searching. Link to case law cited within any court document via Fastcase.

## Analytics At Your Fingertips



Learn what happened the last time a particular judge, opposing counsel or company faced cases similar to yours.

Advanced out-of-the-box PTAB and TTAB analytics are always at your fingertips.

## API

Docket Alarm offers a powerful API (application programming interface) to developers that want to integrate case filings into their apps.

## LAW FIRMS

Build custom dashboards for your attorneys and clients with live data direct from the court.

Automate many repetitive legal tasks like conflict checks, document management, and marketing.

## FINANCIAL INSTITUTIONS

Litigation and bankruptcy checks for companies and debtors.

## E-DISCOVERY AND LEGAL VENDORS

Sync your system to PACER to automate legal marketing.