

UNITED STATES PATENT AND TRADEMARK OFFICE
CERTIFICATE OF CORRECTION

PATENT NO. : 7,761,127 B2
APPLICATION NO. : 11/366209
DATED : July 20, 2010
INVENTOR(S) : Ammar Al-Ali et al.

Page 1 of 1

It is certified that error appears in the above-identified patent and that said Letters Patent is hereby corrected as shown below:

Page 2, Column 2, Line 9, change “ $I_{\lambda} = I_{0\lambda} e^{-d_{\lambda} \cdot \mu_{a,\lambda}}$ ” to -- $I_{\lambda} = I_{0,\lambda} e^{-d_{\lambda} \cdot \mu_{a,\lambda}}$ --.

Claim 13, Column 20, Line 5, change “the substrate” to -- a substrate --.

This certificate supersedes the Certificate of Correction issued January 4, 2011.

Signed and Sealed this
First Day of February, 2011



David J. Kappos
Director of the United States Patent and Trademark Office



UNITED STATES DEPARTMENT OF COMMERCE
Patent and Trademark Office
ASSISTANT SECRETARY OF COMMERCE AND
COMMISSIONER OF PATENTS AND TRADEMARKS
P.O. Box 1450
Alexandria, VA 22313-1450

January 5, 2011

KNOBBE MARTENS OLSON & BEAR LLP
2040 MAIN STREET
FOURTEENTH FLOOR
IRVINE CA 92614

Patent No. : 7,761,127 B2
Inventor(s) : Ammar Al-Ali, et al.
Issued : July 20, 2010
For **MULTIPLE WAVELENGTH SENSOR**
SUBSTRATE
Doc. No.: **MLR.004A**

To Whom It May Concern:

The Certificate of Correction issued on January 4, 2011, issued in error, in that error(s) was made in identifying the patent number and/or keying text/corrections, i.e.:

The column and line number identifying location of error in patent was not printed in the issued cofc. The correction displays "Claim 2", listing claim number. The correction should be shown as --Claim 13, Column 20, line 5--. A new certificate of correction will be issued listing the Column and line number location where error appears in the printed patent.

Therefore, a certificate of correction will be issued to correct (supersede) the Certificate of Correction containing error(s), made during preparation of the Certificate of Correction, as noted above.

No further response is required, from applicants (attorney). However, errors discovered by attorney, other than as noted and described above, should be noted on *a copy* of the Certificate of Correction that was issued in error, accompanied by a signed transmittal letter and submitted directed to this Branch.

Antonio Johnson
(571)272-0483
For Mary F. Diggs, Supervisor
Decisions & Certificates of Correction Branch
(703) 756-1580

UNITED STATES PATENT AND TRADEMARK OFFICE
CERTIFICATE OF CORRECTION

PATENT NO. : 7,761,127 B2
APPLICATION NO. : 11/366209
DATED : July 20, 2010
INVENTOR(S) : Ammar Al-Ali et al.

Page 1 of 1

It is certified that error appears in the above-identified patent and that said Letters Patent is hereby corrected as shown below:

Page 2, Line 9, Column 2, change " $I_{\lambda} = I_{0,\lambda} e^{-d_{\lambda} \cdot \mu_{a,\lambda}}$ " to -- $I_{\lambda} = I_{0,\lambda} e^{-d_{\lambda} \cdot \mu_{a,\lambda}}$ --.

Claim 13, change "the substrate" to -- a substrate --.

Signed and Sealed this
Fourth Day of January, 2011

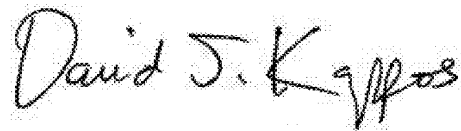

David J. Kappos
Director of the United States Patent and Trademark Office

UNITED STATES PATENT AND TRADEMARK OFFICE
CERTIFICATE OF CORRECTION

PATENT NO. : 7,761,127
APPLICATION NO. : 11/366,209
ISSUE DATE : July 20, 2010
INVENTOR(S) : Ammar Al-Ali, et al.

Page 1 of 1

It is certified that error appears in the above-identified patent and that said Letters Patent is hereby corrected as shown below:

Page 2, Line 9, Column 2, change " $I_{\lambda} = I_{0,\lambda} e^{-d_{\lambda} \cdot \mu_{a,\lambda}}$ " to -- $I_{\lambda} = I_{0,\lambda} e^{-d_{\lambda} \cdot \mu_{a,\lambda}}$ --.

Claim 13, change "the substrate" to -- a substrate --.

9995625
111110

MAILING ADDRESS OF SENDER:

Jarom D. Kesler
KNOBBE, MARTENS, OLSON & BEAR, LLP
2040 Main Street, 14th Floor
Irvine, California 92614

DOCKET NO. MLR.004A

Electronic Acknowledgement Receipt

EFS ID:	8881523
Application Number:	11366209
International Application Number:	
Confirmation Number:	2025
Title of Invention:	MULTIPLE WAVELENGTH SENSOR SUBSTRATE
First Named Inventor/Applicant Name:	Ammar Al-Ali
Customer Number:	20995
Filer:	Jarom D. Kesler/Alexandra Benitez
Filer Authorized By:	Jarom D. Kesler
Attorney Docket Number:	MLR.004A
Receipt Date:	19-NOV-2010
Filing Date:	01-MAR-2006
Time Stamp:	19:56:44
Application Type:	Utility under 35 USC 111(a)

Payment information:

Submitted with Payment	no
------------------------	----

File Listing:

Document Number	Document Description	File Name	File Size(Bytes)/ Message Digest	Multi Part /.zip	Pages (if appl.)
1		MLR_004A.pdf	55144 <small>7473ce327fd505fe0732fadffe0b291ae1ca583</small>	yes	2

Multipart Description/PDF files in .zip description		
Document Description	Start	End
Transmittal Letter	1	1
Request for Certificate of Correction	2	2
Warnings:		
Information:		
Total Files Size (in bytes):		55144
<p>This Acknowledgement Receipt evidences receipt on the noted date by the USPTO of the indicated documents, characterized by the applicant, and including page counts, where applicable. It serves as evidence of receipt similar to a Post Card, as described in MPEP 503.</p> <p><u>New Applications Under 35 U.S.C. 111</u> If a new application is being filed and the application includes the necessary components for a filing date (see 37 CFR 1.53(b)-(d) and MPEP 506), a Filing Receipt (37 CFR 1.54) will be issued in due course and the date shown on this Acknowledgement Receipt will establish the filing date of the application.</p> <p><u>National Stage of an International Application under 35 U.S.C. 371</u> If a timely submission to enter the national stage of an international application is compliant with the conditions of 35 U.S.C. 371 and other applicable requirements a Form PCT/DO/EO/903 indicating acceptance of the application as a national stage submission under 35 U.S.C. 371 will be issued in addition to the Filing Receipt, in due course.</p> <p><u>New International Application Filed with the USPTO as a Receiving Office</u> If a new international application is being filed and the international application includes the necessary components for an international filing date (see PCT Article 11 and MPEP 1810), a Notification of the International Application Number and of the International Filing Date (Form PCT/RO/105) will be issued in due course, subject to prescriptions concerning national security, and the date shown on this Acknowledgement Receipt will establish the international filing date of the application.</p>		

Knobbe Martens Olson & Bear LLP

Intellectual Property Law

2040 Main Street
Fourteenth Floor
Irvine, CA 92614
Tel 949-760-0404
Fax 949-760-9502
www.kmob.com

Jarom D. Kesler
Jarom.Kesler@kmob.com

November 19, 2010

ATTN: Certificate of Correction Branch
Commissioner for Patents
P.O. Box 1450
Alexandria, VA 22313-1450

Re: Title: MULTIPLE WAVELENGTH SENSOR SUBSTRATE
Letters Patent No. 7,761,127
Issued: July 20, 2010
Our Reference: MLR.004A

Dear Sir:

Enclosed for filing is a Certificate of Correction in connection with the above-identified patent.

As the errors cited in the Certificate of Correction were incurred through the fault of the Patent Office, no fee is believed to be required. However, please charge our Deposit Account No. 11-1410 for any fees that may be incurred with this request.

Respectfully submitted,

Knobbe, Martens, Olson & Bear, LLP

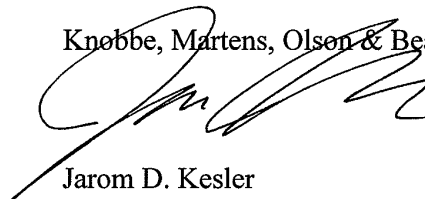

Jarom D. Kesler
Registration No. 57,046
Customer No. 20995

Enclosures

9995760

San Diego
858-836-9000

San Francisco
415-954-4114

Los Angeles
310-551-3450

Riverside
951-781-9231

Seattle
206-405-2000

Washington, DC
202-640-6400



UNITED STATES PATENT AND TRADEMARK OFFICE

UNITED STATES DEPARTMENT OF COMMERCE
United States Patent and Trademark Office
Address: COMMISSIONER FOR PATENTS
P.O. Box 1450
Alexandria, Virginia 22313-1450
www.uspto.gov

Table with 5 columns: APPLICATION NO., ISSUE DATE, PATENT NO., ATTORNEY DOCKET NO., CONFIRMATION NO.
Row 1: 11/366,209, 07/20/2010, 7761127, MLR.004A, 2025

20995 7590 06/30/2010
KNOBBE MARTENS OLSON & BEAR LLP
2040 MAIN STREET
FOURTEENTH FLOOR
IRVINE, CA 92614

ISSUE NOTIFICATION

The projected patent number and issue date are specified above.

Determination of Patent Term Adjustment under 35 U.S.C. 154 (b)

(application filed on or after May 29, 2000)

The Patent Term Adjustment is 1154 day(s). Any patent to issue from the above-identified application will include an indication of the adjustment on the front page.

If a Continued Prosecution Application (CPA) was filed in the above-identified application, the filing date that determines Patent Term Adjustment is the filing date of the most recent CPA.

Applicant will be able to obtain more detailed information by accessing the Patent Application Information Retrieval (PAIR) WEB site (http://pair.uspto.gov).

Any questions regarding the Patent Term Extension or Adjustment determination should be directed to the Office of Patent Legal Administration at (571)-272-7702. Questions relating to issue and publication fee payments should be directed to the Application Assistance Unit (AAU) of the Office of Data Management (ODM) at (571)-272-4200.

APPLICANT(s) (Please see PAIR WEB site http://pair.uspto.gov for additional applicants):

- Ammar Al-Ali, Tustin, CA;
Mohamed Diab, Mission Viejo, CA;
Marcelo Lamego, Rancho Santa Margarita, CA;
James P. Coffin, Mission Viejo, CA;
Yassir Abdul-Hafiz, Irvine, CA;

Electronic Patent Application Fee Transmittal				
Application Number:	11366209			
Filing Date:	01-Mar-2006			
Title of Invention:	MULTIPLE WAVELENGTH SENSOR SUBSTRATE			
First Named Inventor/Applicant Name:	Ammar Al-Ali			
Filer:	Jarom D. Kesler/Nadin Hamoui			
Attorney Docket Number:	MLR.004A			
Filed as Large Entity				
Utility under 35 USC 111(a) Filing Fees				
Description	Fee Code	Quantity	Amount	Sub-Total in USD(\$)
Basic Filing:				
Pages:				
Claims:				
Miscellaneous-Filing:				
Petition:				
Patent-Appeals-and-Interference:				
Post-Allowance-and-Post-Issuance:				
Utility Appl issue fee	1501	1	1510	1510
Publ. Fee- early, voluntary, or normal	1504	1	300	300

Description	Fee Code	Quantity	Amount	Sub-Total in USD(\$)
Extension-of-Time:				
Miscellaneous:				
Total in USD (\$)				1810

Electronic Acknowledgement Receipt

EFS ID:	7796565
Application Number:	11366209
International Application Number:	
Confirmation Number:	2025
Title of Invention:	MULTIPLE WAVELENGTH SENSOR SUBSTRATE
First Named Inventor/Applicant Name:	Ammar Al-Ali
Customer Number:	20995
Filer:	Jarom D. Kesler/Heide Young
Filer Authorized By:	Jarom D. Kesler
Attorney Docket Number:	MLR.004A
Receipt Date:	11-JUN-2010
Filing Date:	01-MAR-2006
Time Stamp:	14:47:43
Application Type:	Utility under 35 USC 111(a)

Payment information:

Submitted with Payment	yes
Payment Type	Credit Card
Payment was successfully received in RAM	\$1810
RAM confirmation Number	1056
Deposit Account	111410
Authorized User	KNOBBE MARTENS OLSON AND BEAR

The Director of the USPTO is hereby authorized to charge indicated fees and credit any overpayment as follows:

Charge any Additional Fees required under 37 C.F.R. Section 1.16 (National application filing, search, and examination fees)

Charge any Additional Fees required under 37 C.F.R. Section 1.17 (Patent application and reexamination processing fees)

File Listing:					
Document Number	Document Description	File Name	File Size(Bytes)/ Message Digest	Multi Part /.zip	Pages (if appl.)
1	Issue Fee Payment (PTO-85B)	lfee.pdf	89433	no	1
			8afd763d42975e41d55c25813d4c94510ac50f01		
Warnings:					
Information:					
2	Fee Worksheet (PTO-875)	fee-info.pdf	31917	no	2
			b860ad0bbfb33e13d594f2a6fd477749e8196841		
Warnings:					
Information:					
Total Files Size (in bytes):			121350		
<p>This Acknowledgement Receipt evidences receipt on the noted date by the USPTO of the indicated documents, characterized by the applicant, and including page counts, where applicable. It serves as evidence of receipt similar to a Post Card, as described in MPEP 503.</p> <p><u>New Applications Under 35 U.S.C. 111</u> If a new application is being filed and the application includes the necessary components for a filing date (see 37 CFR 1.53(b)-(d) and MPEP 506), a Filing Receipt (37 CFR 1.54) will be issued in due course and the date shown on this Acknowledgement Receipt will establish the filing date of the application.</p> <p><u>National Stage of an International Application under 35 U.S.C. 371</u> If a timely submission to enter the national stage of an international application is compliant with the conditions of 35 U.S.C. 371 and other applicable requirements a Form PCT/DO/EO/903 indicating acceptance of the application as a national stage submission under 35 U.S.C. 371 will be issued in addition to the Filing Receipt, in due course.</p> <p><u>New International Application Filed with the USPTO as a Receiving Office</u> If a new international application is being filed and the international application includes the necessary components for an international filing date (see PCT Article 11 and MPEP 1810), a Notification of the International Application Number and of the International Filing Date (Form PCT/RO/105) will be issued in due course, subject to prescriptions concerning national security, and the date shown on this Acknowledgement Receipt will establish the international filing date of the application.</p>					

INFORMATION DISCLOSURE STATEMENT BY APPLICANT	Application No.	11/366,209
	Filing Date	March 1, 2006
	First Named Inventor	Ammar Al-Ali et al.
	Art Unit	3735
(Multiple sheets used when necessary)	Examiner	
SHEET 5 OF 13	Attorney Docket No.	MLR.004A

U.S. PATENT DOCUMENTS					
Examiner Initials	Cite No.	Document Number Number - Kind Code (if known) Example: 1,234,567 B1	Publication Date MM-DD-YYYY	Name of Patentee or Applicant	Pages, Columns, Lines Where Relevant Passages or Relevant Figures Appear
	106	6,397,092	05-28-2002	Norris et al.	
	107	6,393,310	05-21-2002	Kuenstner	
	108	6,377,828	04-23-2002	Chaiken, et al.	
	109	6,374,129	04-16-2002	Chin, et al.	
	110	6,363,269	03-26-2002	Hanna et al.	
	111	6,356,774 3/02	01-12-2002	Bernstein et al.	
	112	6,351,658	02-26-2002	Middleman et al.	
	113	6,341,257	01-22-2002	Haaland	
	114	6,330,468	12-11-2001	Scharf	
	115	6,304,767	10-16-2001	Soller et al.	
	116	6,304,675	10-16-2001	Osbourm et al.	
	117	6,298,252	10-02-2001	Kovach et al.	
	118	6,272,363	08-07-2001	Casciani et al.	
	119	6,230,035	05-08-2001	Aoyagi et al.	
	120	6,226,539	05-01-2001	Potratz	
	121	6,157,041	12-05-2000	Thomas et al.	
	122	6,154,667	11-28-2000	Miura et al.	
	123	6,151,518	11-21-2000	Hayashi	
	124	6,112,107	08-29-2000	Hannula	
	125	6,104,938	08-15-2000	Huiku	
	126	6,094,592	07-25-2000	Yorkey et al.	
	127	6,083,172	07-04-2000	Baker JR. et al.	
	128	6,073,037	06-06-2000	Alam et al.	
	129	6,068,594	05-30-2000	Schloemer et al.	
	130	6,064,898	05-16-2000	Aldrich	
	131	6,023,541	02-08-2000	Merchant et al.	

PAP
5/12/10

Examiner Signature	Date Considered
*Examiner: Initial if reference considered, whether or not citation is in conformance with MPEP 609. Draw line through citation if not in conformance and not considered. Include copy of this form with next communication to applicant.	

T¹ - Place a check mark in this area when an English language Translation is attached.

ALL REFERENCES CONSIDERED EXCEPT WHERE LINED THROUGH. /EB/

INFORMATION DISCLOSURE STATEMENT BY APPLICANT	Application No.	11/366,209
	Filing Date	March 1, 2006
	First Named Inventor	Ammar Al-Ali
	Art Unit	3735
(Multiple sheets used when necessary)		Examiner
SHEET 5 OF 6		Attorney Docket No. MLR.004A

U.S. PATENT DOCUMENTS					
Examiner Initials	Cite No.	Document Number Number - Kind Code (if known) Example: 1,234,567 B1	Publication Date MM-DD-YYYY	Name of Patentee or Applicant	Pages, Columns, Lines Where Relevant Passages or Relevant Figures Appear
	117	5,791,347	08/1998	Flaherty, et al.	
	118	5,785,659	07/1998	Caro, et al.	
	119	5,782,757	07/1998	Diab, et al.	
	120	5,769,785	06/1998	Diab, et al.	
	121	5,760,910	06/1998	Lepper, Jr., et al.	
	122	5,758,644	06/1998	Diab, et al.	
	123	5,743,262	04/1998	Lepper, Jr., et al.	
	124	Des. 393,830	04/1998	Tobler, et al.	
	125	5,685,299	11/1997	Diab, et al.	
	126	5,645,440	07/1997	Tobler, et al.	
	127	5,638,818	06/1997	Diab, et al.	
	128	5,638,816	06/1997	Kiani-Azarbayjany, et al.	
	129	5,632,272	05/1997	Diab, et al.	
	130	5,602,924	02/1997	Durand, et al.	
	131	5,590,649	01/1997	Caro, et al.	
	132	5,562,002 10/96	10/1996	Lalin	
	133	5,533,511	07/1996	Kaspari, et al.	
	134	5,494,043	02/1996	O'Sullivan, et al.	
	135	5,490,505	02/1996	Diab, et al.	
	136	5,482,036	01/1996	Diab, et al.	
	137	D363,120	10/1995	Savage, et al.	
	138	5,452,717	09/1995	Branigan, et al.	
	139	D362,063	09/1995	Savage, et al.	
	140	D361,840	08/1995	Savage, et al.	
	141	5,431,170	07/1995	Mathews	
	142	D353,196	12/1994	Savage, et al.	
	143	D353,195	12/1994	Savage, et al.	
	144	5,337,744	08/1994	Branigan	
	145	5,163,438	11/1992	Gordon, et al.	

PP
5/12/10

Examiner Signature	Date Considered
<p>*Examiner: Initial if reference considered, whether or not citation is in conformance with MPEP 609. Draw line through citation if not in conformance and not considered. Include copy of this form with next communication to applicant.</p>	

T¹ - Place a check mark in this area when an English language Translation is attached.

ALL REFERENCES CONSIDERED EXCEPT WHERE LINED THROUGH. /EB/



PTO/SB/08 Equivalent

INFORMATION DISCLOSURE STATEMENT BY APPLICANT <i>(Multiple sheets used when necessary)</i> SHEET 1 OF 2	Application No.	11/366,209
	Filing Date	March 1, 2006
	First Named Inventor	Al-Ali, et al.
	Art Unit	3735
	Examiner	Unknown
		Attorney Docket No. MLR.004A

U.S. PATENT DOCUMENTS

Examiner Initials	Cite No.	Document Number Number - Kind Code (if known) Example: 1,234,567 B1	Publication Date MM-DD-YYYY	Name of Patentee or Applicant	Pages, Columns, Lines Where Relevant Passages or Relevant Figures Appear
	1	6,743,172	6/1/04	Blike	
	2	6,611,698	8/26/03	Yamashita et al.	
	3	6,253,097	6/26/01	Aronow et al.	
	4	6,184,521	2/6/01	Coffin IV et al.	
	5	6,122,042	9/19/00	Wunderman et al.	
	6	5,800,348	1/9/98	Kaestle et al.	
	7	5,645,059	7/8/97	Fein et al.	
	8	5,331,549	7/19/94	Crawford Jr.	
	9	5,259,381	11/9/93	Cheung et al.	
	10	5,058,588	10/22/91	Kaestle et al.	
	11	4,986,665	1/22/91	Yamanishi et al.	
	12	4,907,876	3/13/90	Suzuki et al.	
	13	2005/0011488	2/10/05	Al Ali et al.	
	14	2004/0267103	12/30/04	Li Luya et al.	
	15	2004/0262046	12/30/04	Simon et al.	
	16	2004/0158134	8/12/04	Diab et al.	
	17	2004/0147823	7/29/04	Kiani et al.	
	18	2004/0133087	7/8/04	Al Ali et al.	
	19	2004/0081621	4/29/04	Arndt et al.	
	20	2004/0059209	3/25/04	Al Ali et al.	
	21	2004/0034898	2/10/05	Al Ali et al.	
	22	2002/0183819	12/5/02	Struble	
	23	2002/0161291	10/31/02	Kiani et al.	
	24	2002/0038081	3/28/02	Fein et al.	
	25	2002/0021269 2/02 2/24/00	2/24/00	Rast	
	26	2001/0044700	11/22/01	Koboyashi et al.	

RSP
5/12/10

FOREIGN PATENT DOCUMENTS

Examiner Signature	Date Considered
*Examiner: Initial if reference considered, whether or not citation is in conformance with MPEP 609. Draw line through citation if not in conformance and not considered. Include copy of this form with next communication to applicant.	

T¹ - Place a check mark in this area when an English language Translation is attached.

ALL REFERENCES CONSIDERED EXCEPT WHERE LINED THROUGH. /EB/



UNITED STATES PATENT AND TRADEMARK OFFICE

UNITED STATES DEPARTMENT OF COMMERCE
United States Patent and Trademark Office
Address: COMMISSIONER FOR PATENTS
P.O. Box 1450
Alexandria, Virginia 22313-1450
www.uspto.gov

Table with 5 columns: APPLICATION NO., FILING DATE, FIRST NAMED INVENTOR, ATTORNEY DOCKET NO., CONFIRMATION NO. Includes details for application 11/366,209 filed 03/01/2006 by Ammar Al-Ali, attorney MLR.004A, confirmation 2025. Also includes examiner BERHANU, ETSUB D, art unit 3768, and notification date 05/06/2010 via electronic mode.

Please find below and/or attached an Office communication concerning this application or proceeding.

The time period for reply, if any, is set in the attached communication.

Notice of the Office communication was sent electronically on above-indicated "Notification Date" to the following e-mail address(es):

- jcartec@kmob.com
efiling@kmob.com
eOAPilot@kmob.com

Response to Rule 312 Communication

Application No.	Applicant(s)
11/366,209	AL-ALI ET AL.
Examiner	Art Unit
ETSUB D. BERHANU	3768

-- The MAILING DATE of this communication appears on the cover sheet with the correspondence address --

1. The amendment filed on 26 April 2010 under 37 CFR 1.312 has been considered, and has been:
- a) entered.
 - b) entered as directed to matters of form not affecting the scope of the invention.
 - c) disapproved because the amendment was filed after the payment of the issue fee.
Any amendment filed after the date the issue fee is paid must be accompanied by a petition under 37 CFR 1.313(c)(1) and the required fee to withdraw the application from issue.
 - d) disapproved. See explanation below.
 - e) entered in part. See explanation below.

/Eric F Winakur/
Primary Examiner, Art Unit 3768

OK TO ENTER: /EB/ (04/29/2010)

MLR.004A

PATENT

IN THE UNITED STATES PATENT AND TRADEMARK OFFICE

Applicant : Ammar Al-Ali, et al.
App. No : 11/366,209
Filed : March 1, 2006
For : MULTIPLE WAVELENGTH SENSOR
SUBSTRATE
Examiner : Berhanu, Etsub D.
Art Unit : 3768
Conf No. : 2025

CERTIFICATE OF EFS WEB
TRANSMISSION

I hereby certify that this correspondence, and any other attachment noted on the automated Acknowledgement Receipt, is being transmitted from within the Pacific Time zone to the Commissioner for Patents via the EFS Web server on:

April 26, 2010

(Date)

/Jarom D. Kesler/

Jarom D. Kesler, Reg. No. 57,046

AMENDMENT AFTER NOTICE OF ALLOWANCE UNDER 37 CFR 1.312

Mail Stop Amendment

Commissioner for Patents

P.O. Box 1450

Alexandria, VA 22313-1450

Dear Sir:

Please amend the above-identified application as follows:

Amendments to the Specification begin on page 2 of this paper.

Remarks begin on page 3 of this paper.

IN THE UNITED STATES PATENT AND TRADEMARK OFFICE

Applicant : Ammar Al-Ali, et al.
 App. No : 11/366,209
 Filed : March 1, 2006
 For : MULTIPLE WAVELENGTH SENSOR
 SUBSTRATE
 Examiner : Berhanu, Etsub D.
 Art Unit : 3768
 Conf No. : 2025

CERTIFICATE OF EFS WEB
 TRANSMISSION

I hereby certify that this correspondence, and any other attachment noted on the automated Acknowledgement Receipt, is being transmitted from within the Pacific Time zone to the Commissioner for Patents via the EFS Web server on:

April 26, 2010

(Date)

/Jarom D. Kesler/

Jarom D. Kesler, Reg. No. 57,046

AMENDMENT AFTER NOTICE OF ALLOWANCE UNDER 37 CFR 1.312**Mail Stop Amendment**

Commissioner for Patents
 P.O. Box 1450
 Alexandria, VA 22313-1450

Dear Sir:

Please amend the above-identified application as follows:

Amendments to the Specification begin on page 2 of this paper.

Remarks begin on page 3 of this paper.

Application No.: 11/366,209
Filing Date: March 1, 2006

AMENDMENTS TO THE SPECIFICATION

Please amend paragraph [0002] of the Specification as follows with additions underlined and deletions shown in strikethrough or using double brackets:

[0002] The present application is related to the following copending U.S. utility applications:

	App. Sr. No.	Filing Date	Title	Atty Dock.
1	[[11/####,###]] <u>11/367,013</u>	March 1, 2006	Multiple Wavelength Sensor Emitters	MLR.002A
2	[[11/####,###]] <u>11/366,995</u>	March 1, 2006	Multiple Wavelength Sensor Equalization	MLR.003A
3	[[11/####,###]] <u>11/366,210</u>	March 1, 2006	Multiple Wavelength Sensor Interconnect	MLR.005A
4	[[11/####,###]] <u>11/366,833</u>	March 1, 2006	Multiple Wavelength Sensor Attachment	MLR.006A
5	[[11/####,###]] <u>11/366,997</u>	March 1, 2006	Multiple Wavelength Sensor Drivers	MLR.009A
6	[[11/####,###]] <u>11/367,034</u>	March 1, 2006	Physiological Parameter Confidence Measure	MLR.010A
7	[[11/####,###]] <u>11/367,036</u>	March 1, 2006	Configurable Physiological Measurement System	MLR.011A
8	[[11/####,###]] <u>11/367,033</u>	March 1, 2006	Noninvasive Multi- Parameter Patient Monitor	MLR.012A
9	[[11/####,###]] <u>11/367,014</u>	March 1, 2006	Noninvasive Multi- Parameter Patient Monitor	MLR.013A
10	[[11/####,###]] <u>11/366,208</u>	March 1, 2006	Noninvasive Multi- Parameter Patient Monitor	MLR.014A

Application No.: 11/366,209
Filing Date: March 1, 2006

REMARKS

In this amendment, Applicants have amended the Specification to include the serial numbers of the related applications incorporated by reference and filed on the same day as the present Application. Applicant submits that no new matter has been added through the amendments.

Please charge any additional fees, including any fees for additional extension of time, or credit overpayment to Deposit Account No. 11-1410.

Respectfully submitted,

KNOBBE, MARTENS, OLSON & BEAR, LLP

Dated: April 26, 2010

By: _____/Jarom D. Kesler/

Jarom D. Kesler
Registration No. 57,046
Attorney of Record
Customer No. 20995
(949) 760-0404

8890699

Electronic Acknowledgement Receipt

EFS ID:	7492497
Application Number:	11366209
International Application Number:	
Confirmation Number:	2025
Title of Invention:	MULTIPLE WAVELENGTH SENSOR SUBSTRATE
First Named Inventor/Applicant Name:	Ammar Al-Ali
Customer Number:	20995
Filer:	Jarom D. Kesler/Shirley Martinez
Filer Authorized By:	Jarom D. Kesler
Attorney Docket Number:	MLR.004A
Receipt Date:	26-APR-2010
Filing Date:	01-MAR-2006
Time Stamp:	20:54:25
Application Type:	Utility under 35 USC 111(a)

Payment information:

Submitted with Payment	no
------------------------	----

File Listing:

Document Number	Document Description	File Name	File Size(Bytes)/ Message Digest	Multi Part /.zip	Pages (if appl.)
1		4a.pdf	71210 fc0a90c26a195c3f69234d0eb621bb5ba2f03dd4	yes	3

Multipart Description/PDF files in .zip description		
Document Description	Start	End
Amendment after Notice of Allowance (Rule 312)	1	1
Specification	2	2
Applicant Arguments/Remarks Made in an Amendment	3	3

Warnings:

Information:

Total Files Size (in bytes):	71210
-------------------------------------	-------

This Acknowledgement Receipt evidences receipt on the noted date by the USPTO of the indicated documents, characterized by the applicant, and including page counts, where applicable. It serves as evidence of receipt similar to a Post Card, as described in MPEP 503.

New Applications Under 35 U.S.C. 111

If a new application is being filed and the application includes the necessary components for a filing date (see 37 CFR 1.53(b)-(d) and MPEP 506), a Filing Receipt (37 CFR 1.54) will be issued in due course and the date shown on this Acknowledgement Receipt will establish the filing date of the application.

National Stage of an International Application under 35 U.S.C. 371

If a timely submission to enter the national stage of an international application is compliant with the conditions of 35 U.S.C. 371 and other applicable requirements a Form PCT/DO/EO/903 indicating acceptance of the application as a national stage submission under 35 U.S.C. 371 will be issued in addition to the Filing Receipt, in due course.

New International Application Filed with the USPTO as a Receiving Office

If a new international application is being filed and the international application includes the necessary components for an international filing date (see PCT Article 11 and MPEP 1810), a Notification of the International Application Number and of the International Filing Date (Form PCT/RO/105) will be issued in due course, subject to prescriptions concerning national security, and the date shown on this Acknowledgement Receipt will establish the international filing date of the application.

INFORMATION DISCLOSURE STATEMENT BY APPLICANT (Multiple sheets used when necessary) SHEET 1 OF 6	Application No.	11/366,209
	Filing Date	March 1, 2006
	First Named Inventor	Ammar Al-Ali
	Art Unit	3735
	Examiner	
	Attorney Docket No.	MLR.004A

U.S. PATENT DOCUMENTS

Initials	Cite No.	Document Number Number - Kind Code (if known) Example: 1,234,567 B1	Publication Date MM-DD-YYYY	Name of Patentee or Applicant	Pages, Columns, Lines Where Relevant Passages or Relevant Figures Appear
	1	7,044,918	05/2006	Diab	
	2	7,041,060	05/2006	Flaherty, et al	
	3	7,039,449	05/2006	Al-Ali	
	4	7,030,749	04/2006	Al-Ali	
	5	7,027,849	04/2006	Al-Ali	
	6	7,024,233	04/2006	Al, et al.	
	7	7,015,451 3/06	02/2006	Dalke, et al.	
	8	7,003,339	02/2006	Diab, et al.	
	9	7,003,338	02/2006	Weber, et al.	
	10	6,999,904	02/2006	Weber, et al.	
	11	6,996,427	02/2006	Ali, et al.	
	12	6,993,371	01/2006	Kiani, et al.	
	13	6,985,764	01/2006	Mason, et al.	
	14	6,979,812	12/2005	Al-Ali	
	15	6,970,792	11/2005	Diab	
	16	6,961,598	11/2005	Diab	
	17	6,950,687	09/2005	Al-Ali	
	18	6,943,348	09/2005	Coffin, IV	
	19	6,939,305	09/2005	Flaherty, et al.	
	20	6,934,570	08/2005	Kiani, et al.	
	21	6,931,268	08/2005	Kiani-Azarbayjany, et al.	
	22	6,920,345	07/2005	Al-Ali, et al.	
	23	6,898,452	05/2005	Al-Ali, et al.	
	24	6,861,639	03/2005	Al-Ali	
	25	6,852,083	02/2005	Caro, et al.	
	26	6,850,788	02/2005	Al-Ali	
	27	6,850,787	02/2005	Weber, et al.	
	28	6,830,711	12/2004	Mills, et al.	
	29	6,826,419	11/2004	Diab, et al.	

Examiner Signature	Date Considered
*Examiner: Initial if reference considered, whether or not citation is in conformance with MPEP 609. Draw line through citation if not in conformance and not considered. Include copy of this form with next communication to applicant.	

T¹ - Place a check mark in this area when an English language Translation is attached.

ALL REFERENCES CONSIDERED EXCEPT WHERE LINED THROUGH. /EB/



PTO/SB/08 Equivalent

INFORMATION DISCLOSURE STATEMENT BY APPLICANT (Multiple sheets used when necessary)	Application No.	11/366,209
	Filing Date	March 1, 2006
	First Named Inventor	Al-Ali, et al.
	Art Unit	3735
SHEET 1 OF 2	Examiner	Unknown
	Attorney Docket No.	MLR.004A

U.S. PATENT DOCUMENTS

Examiner Initials	Cite No.	Document Number Number - Kind Code (if known) Example: 1,234,567 B1	Publication Date MM-DD-YYYY	Name of Patentee or Applicant	Pages, Columns, Lines Where Relevant Passages or Relevant Figures Appear
	1	6,743,172	6/1/04	Blike	
	2	6,611,698	8/26/03	Yamashita et al.	
	3	6,253,097	6/26/01	Aronow et al.	
	4	6,184,521	2/8/01	Coffin IV et al.	
	5	6,122,042	9/19/00	Wunderman et al.	
	6	5,800,348 9/98	1/9/98	Kaestle et al.	
	7	5,645,059	7/8/97	Fein et al.	
	8	5,331,549	7/19/94	Crawford Jr.	
	9	5,259,381	11/9/93	Cheung et al.	
	10	5,058,588	10/22/91	Kaestle et al.	
	11	4,986,665	1/22/91	Yamanishi et al.	
	12	4,907,876	3/13/90	Suzuki et al.	
	13	2005/0011488	2/10/05	Al Ali et al.	
	14	2004/0267103	12/30/04	Li Luya et al.	
	15	2004/0262046	12/30/04	Simon et al.	
	16	2004/0158134	8/12/04	Diab et al.	
	17	2004/0147823	7/29/04	Kiani et al.	
	18	2004/0133087	7/8/04	Al Ali et al.	
	19	2004/0081621	4/29/04	Amdt et al.	
	20	2004/0059209	3/25/04	Al Ali et al.	
	21	2004/0034898	2/10/05	Al Ali et al.	
	22	2002/0183819	12/5/02	Struble	
	23	2002/0161291	10/31/02	Kiani et al.	
	24	2002/0038081	3/28/02	Fein et al.	
	25	2002/0021269	2/21/00	Rast	
	26	2001/0044700	11/22/01	Koboyashi et al.	

PAP
4/23/06

FOREIGN PATENT DOCUMENTS

Examiner Signature	Date Considered
*Examiner: Initial if reference considered, whether or not citation is in conformance with MPEP 609. Draw line through citation if not in conformance and not considered. Include copy of this form with next communication to applicant.	

T - Place a check mark in this area when an English language Translation is attached.

ALL REFERENCES CONSIDERED EXCEPT WHERE LINED THROUGH. /EB/

IN THE UNITED STATES PATENT AND TRADEMARK OFFICE

Applicant : Ammar Al-Ali, et al.
 App. No : 11/366,209
 Filed : March 1, 2006
 For : MULTIPLE WAVELENGTH SENSOR
 SUBSTRATE
 Examiner : Berhanu, Etsub D.
 Art Unit : 3768
 Conf No. : 2025

CERTIFICATE OF EFS WEB TRANSMISSION

I hereby certify that this correspondence, and any other attachment noted on the automated Acknowledgement Receipt, is being transmitted from within the Pacific Time zone to the Commissioner for Patents via the EFS Web server on:

April 15, 2010

(Date)

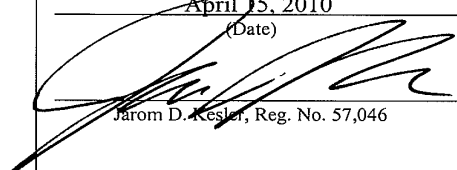

Jarom D. Kesler, Reg. No. 57,046

AMENDMENT AFTER NOTICE OF ALLOWANCE UNDER 37 CFR 1.312

Mail Stop Amendment

Commissioner for Patents
P.O. Box 1450
Alexandria, VA 22313-1450

Dear Sir:

Please amend the above-identified application as follows:

Amendments to the Specification begin on page 2 of this paper.

Remarks begin on page 3 of this paper.

Application No.: 11/366,209
Filing Date: March 1, 2006

AMENDMENTS TO THE SPECIFICATION

Please replace paragraph [0002] of the Specification with the following:

[0002] The present application is related to the following copending U.S. utility applications:

	App. Sr. No.	Filing Date	Title	Atty Dock.
1	11/367,013	March 1, 2006	Multiple Wavelength Sensor Emitters	MLR.002A
2	11/366,995	March 1, 2006	Multiple Wavelength Sensor Equalization	MLR.003A
3	11/366,210	March 1, 2006	Multiple Wavelength Sensor Interconnect	MLR.005A
4	11/366,833	March 1, 2006	Multiple Wavelength Sensor Attachment	MLR.006A
5	11/366,997	March 1, 2006	Multiple Wavelength Sensor Drivers	MLR.009A
6	11/367,034	March 1, 2006	Physiological Parameter Confidence Measure	MLR.010A
7	11/367,036	March 1, 2006	Configurable Physiological Measurement System	MLR.011A
8	11/367,033	March 1, 2006	Noninvasive Multi- Parameter Patient Monitor	MLR.012A
9	11/367,014	March 1, 2006	Noninvasive Multi- Parameter Patient Monitor	MLR.013A
10	11/366,208	March 1, 2006	Noninvasive Multi- Parameter Patient Monitor	MLR.014A

Application No.: 11/366,209
Filing Date: March 1, 2006

REMARKS

In this amendment, Applicants have amended the Specification to include the serial numbers of the related applications incorporated by reference and filed on the same day as the present Application. Applicant submits that no new matter has been added through the amendments.

Please charge any additional fees, including any fees for additional extension of time, or credit overpayment to Deposit Account No. 11-1410.

Respectfully submitted,

KNOBBE, MARTENS, OLSON & BEAR, LLP

Dated: April 15, 2010

By

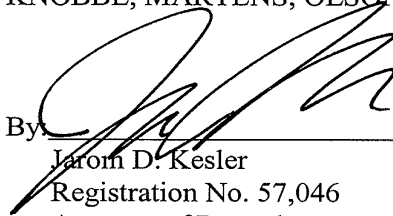

Jarom D. Kesler
Registration No. 57,046
Attorney of Record
Customer No.
(949) 760-0404

8890699

Electronic Acknowledgement Receipt

EFS ID:	7422414
Application Number:	11366209
International Application Number:	
Confirmation Number:	2025
Title of Invention:	MULTIPLE WAVELENGTH SENSOR SUBSTRATE
First Named Inventor/Applicant Name:	Ammar Al-Ali
Customer Number:	20995
Filer:	Jarom D. Kesler/Alexandra Benitez
Filer Authorized By:	Jarom D. Kesler
Attorney Docket Number:	MLR.004A
Receipt Date:	15-APR-2010
Filing Date:	01-MAR-2006
Time Stamp:	17:55:01
Application Type:	Utility under 35 USC 111(a)

Payment information:

Submitted with Payment	no
------------------------	----

File Listing:

Document Number	Document Description	File Name	File Size(Bytes)/ Message Digest	Multi Part /.zip	Pages (if appl.)
1		004A.pdf	78370 25cbd567d3d9ae96fa0618170faa13aa3d4d75fd	yes	3

Multipart Description/PDF files in .zip description		
Document Description	Start	End
Amendment after Notice of Allowance (Rule 312)	1	1
Specification	2	2
Applicant Arguments/Remarks Made in an Amendment	3	3

Warnings:

Information:

Total Files Size (in bytes):	78370
-------------------------------------	-------

This Acknowledgement Receipt evidences receipt on the noted date by the USPTO of the indicated documents, characterized by the applicant, and including page counts, where applicable. It serves as evidence of receipt similar to a Post Card, as described in MPEP 503.

New Applications Under 35 U.S.C. 111

If a new application is being filed and the application includes the necessary components for a filing date (see 37 CFR 1.53(b)-(d) and MPEP 506), a Filing Receipt (37 CFR 1.54) will be issued in due course and the date shown on this Acknowledgement Receipt will establish the filing date of the application.

National Stage of an International Application under 35 U.S.C. 371

If a timely submission to enter the national stage of an international application is compliant with the conditions of 35 U.S.C. 371 and other applicable requirements a Form PCT/DO/EO/903 indicating acceptance of the application as a national stage submission under 35 U.S.C. 371 will be issued in addition to the Filing Receipt, in due course.

New International Application Filed with the USPTO as a Receiving Office

If a new international application is being filed and the international application includes the necessary components for an international filing date (see PCT Article 11 and MPEP 1810), a Notification of the International Application Number and of the International Filing Date (Form PCT/RO/105) will be issued in due course, subject to prescriptions concerning national security, and the date shown on this Acknowledgement Receipt will establish the international filing date of the application.



UNITED STATES PATENT AND TRADEMARK OFFICE

UNITED STATES DEPARTMENT OF COMMERCE
United States Patent and Trademark Office
Address: COMMISSIONER FOR PATENTS
P.O. Box 1450
Alexandria, Virginia 22313-1450
www.uspto.gov

NOTICE OF ALLOWANCE AND FEE(S) DUE

20995 7590 03/12/2010

KNOBBE MARTENS OLSON & BEAR LLP
2040 MAIN STREET
FOURTEENTH FLOOR
IRVINE, CA 92614

EXAMINER

BERHANU, ETSUB D

ART UNIT PAPER NUMBER

3768

DATE MAILED: 03/12/2010

Table with 5 columns: APPLICATION NO., FILING DATE, FIRST NAMED INVENTOR, ATTORNEY DOCKET NO., CONFIRMATION NO.
11/366,209 03/01/2006 Ammar Al-Ali MLR.004A 2025

TITLE OF INVENTION: MULTIPLE WAVELENGTH SENSOR SUBSTRATE

Table with 7 columns: APPLN. TYPE, SMALL ENTITY, ISSUE FEE DUE, PUBLICATION FEE DUE, PREV. PAID ISSUE FEE, TOTAL FEE(S) DUE, DATE DUE
nonprovisional NO \$1510 \$300 \$0 \$1810 06/14/2010

THE APPLICATION IDENTIFIED ABOVE HAS BEEN EXAMINED AND IS ALLOWED FOR ISSUANCE AS A PATENT. PROSECUTION ON THE MERITS IS CLOSED. THIS NOTICE OF ALLOWANCE IS NOT A GRANT OF PATENT RIGHTS. THIS APPLICATION IS SUBJECT TO WITHDRAWAL FROM ISSUE AT THE INITIATIVE OF THE OFFICE OR UPON PETITION BY THE APPLICANT. SEE 37 CFR 1.313 AND MPEP 1308.

THE ISSUE FEE AND PUBLICATION FEE (IF REQUIRED) MUST BE PAID WITHIN THREE MONTHS FROM THE MAILING DATE OF THIS NOTICE OR THIS APPLICATION SHALL BE REGARDED AS ABANDONED. THIS STATUTORY PERIOD CANNOT BE EXTENDED. SEE 35 U.S.C. 151. THE ISSUE FEE DUE INDICATED ABOVE DOES NOT REFLECT A CREDIT FOR ANY PREVIOUSLY PAID ISSUE FEE IN THIS APPLICATION. IF AN ISSUE FEE HAS PREVIOUSLY BEEN PAID IN THIS APPLICATION (AS SHOWN ABOVE), THE RETURN OF PART B OF THIS FORM WILL BE CONSIDERED A REQUEST TO REAPPLY THE PREVIOUSLY PAID ISSUE FEE TOWARD THE ISSUE FEE NOW DUE.

HOW TO REPLY TO THIS NOTICE:

I. Review the SMALL ENTITY status shown above.

If the SMALL ENTITY is shown as YES, verify your current SMALL ENTITY status:

A. If the status is the same, pay the TOTAL FEE(S) DUE shown above.

B. If the status above is to be removed, check box 5b on Part B - Fee(s) Transmittal and pay the PUBLICATION FEE (if required) and twice the amount of the ISSUE FEE shown above, or

If the SMALL ENTITY is shown as NO:

A. Pay TOTAL FEE(S) DUE shown above, or

B. If applicant claimed SMALL ENTITY status before, or is now claiming SMALL ENTITY status, check box 5a on Part B - Fee(s) Transmittal and pay the PUBLICATION FEE (if required) and 1/2 the ISSUE FEE shown above.

II. PART B - FEE(S) TRANSMITTAL, or its equivalent, must be completed and returned to the United States Patent and Trademark Office (USPTO) with your ISSUE FEE and PUBLICATION FEE (if required). If you are charging the fee(s) to your deposit account, section "4b" of Part B - Fee(s) Transmittal should be completed and an extra copy of the form should be submitted. If an equivalent of Part B is filed, a request to reapply a previously paid issue fee must be clearly made, and delays in processing may occur due to the difficulty in recognizing the paper as an equivalent of Part B.

III. All communications regarding this application must give the application number. Please direct all communications prior to issuance to Mail Stop ISSUE FEE unless advised to the contrary.

IMPORTANT REMINDER: Utility patents issuing on applications filed on or after Dec. 12, 1980 may require payment of maintenance fees. It is patentee's responsibility to ensure timely payment of maintenance fees when due.

PART B - FEE(S) TRANSMITTAL

**Complete and send this form, together with applicable fee(s), to: Mail Mail Stop ISSUE FEE
 Commissioner for Patents
 P.O. Box 1450
 Alexandria, Virginia 22313-1450
 or Fax (571)-273-2885**

INSTRUCTIONS: This form should be used for transmitting the ISSUE FEE and PUBLICATION FEE (if required). Blocks 1 through 5 should be completed where appropriate. All further correspondence including the Patent, advance orders and notification of maintenance fees will be mailed to the current correspondence address as indicated unless corrected below or directed otherwise in Block 1, by (a) specifying a new correspondence address; and/or (b) indicating a separate "FEE ADDRESS" for maintenance fee notifications.

CURRENT CORRESPONDENCE ADDRESS (Note: Use Block 1 for any change of address)

20995 7590 03/12/2010

KNOBBE MARTENS OLSON & BEAR LLP
 2040 MAIN STREET
 FOURTEENTH FLOOR
 IRVINE, CA 92614

Note: A certificate of mailing can only be used for domestic mailings of the Fee(s) Transmittal. This certificate cannot be used for any other accompanying papers. Each additional paper, such as an assignment or formal drawing, must have its own certificate of mailing or transmission.

Certificate of Mailing or Transmission

I hereby certify that this Fee(s) Transmittal is being deposited with the United States Postal Service with sufficient postage for first class mail in an envelope addressed to the Mail Stop ISSUE FEE address above, or being facsimile transmitted to the USPTO (571) 273-2885, on the date indicated below.

(Depositor's name)
(Signature)
(Date)

APPLICATION NO.	FILING DATE	FIRST NAMED INVENTOR	ATTORNEY DOCKET NO.	CONFIRMATION NO.
11/366,209	03/01/2006	Ammar Al-Ali	MLR.004A	2025

TITLE OF INVENTION: MULTIPLE WAVELENGTH SENSOR SUBSTRATE

APPLN. TYPE	SMALL ENTITY	ISSUE FEE DUE	PUBLICATION FEE DUE	PREV. PAID ISSUE FEE	TOTAL FEE(S) DUE	DATE DUE
nonprovisional	NO	\$1510	\$300	\$0	\$1810	06/14/2010

EXAMINER	ART UNIT	CLASS-SUBCLASS
BERHANU, ETSUB D	3768	600-310000

1. Change of correspondence address or indication of "Fee Address" (37 CFR 1.363). <input type="checkbox"/> Change of correspondence address (or Change of Correspondence Address form PTO/SB/122) attached. <input type="checkbox"/> "Fee Address" indication (or "Fee Address" Indication form PTO/SB/47; Rev 03-02 or more recent) attached. Use of a Customer Number is required.	2. For printing on the patent front page, list (1) the names of up to 3 registered patent attorneys or agents OR, alternatively, 1 _____ (2) the name of a single firm (having as a member a registered attorney or agent) and the names of up to 2 registered patent attorneys or agents. If no name is listed, no name will be printed. 2 _____ 3 _____
--	--

3. ASSIGNEE NAME AND RESIDENCE DATA TO BE PRINTED ON THE PATENT (print or type)
 PLEASE NOTE: Unless an assignee is identified below, no assignee data will appear on the patent. If an assignee is identified below, the document has been filed for recordation as set forth in 37 CFR 3.11. Completion of this form is NOT a substitute for filing an assignment.
 (A) NAME OF ASSIGNEE _____ (B) RESIDENCE: (CITY and STATE OR COUNTRY) _____

Please check the appropriate assignee category or categories (will not be printed on the patent): Individual Corporation or other private group entity Government

4a. The following fee(s) are submitted: <input type="checkbox"/> Issue Fee <input type="checkbox"/> Publication Fee (No small entity discount permitted) <input type="checkbox"/> Advance Order - # of Copies _____	4b. Payment of Fee(s): (Please first reapply any previously paid issue fee shown above) <input type="checkbox"/> A check is enclosed. <input type="checkbox"/> Payment by credit card. Form PTO-2038 is attached. <input type="checkbox"/> The Director is hereby authorized to charge the required fee(s), any deficiency, or credit any overpayment, to Deposit Account Number _____ (enclose an extra copy of this form).
--	---

5. **Change in Entity Status** (from status indicated above)
 a. Applicant claims SMALL ENTITY status. See 37 CFR 1.27. b. Applicant is no longer claiming SMALL ENTITY status. See 37 CFR 1.27(g)(2).

NOTE: The Issue Fee and Publication Fee (if required) will not be accepted from anyone other than the applicant; a registered attorney or agent; or the assignee or other party in interest as shown by the records of the United States Patent and Trademark Office.

Authorized Signature _____ Date _____
 Typed or printed name _____ Registration No. _____

This collection of information is required by 37 CFR 1.311. The information is required to obtain or retain a benefit by the public which is to file (and by the USPTO to process) an application. Confidentiality is governed by 35 U.S.C. 122 and 37 CFR 1.14. This collection is estimated to take 12 minutes to complete, including gathering, preparing, and submitting the completed application form to the USPTO. Time will vary depending upon the individual case. Any comments on the amount of time you require to complete this form and/or suggestions for reducing this burden, should be sent to the Chief Information Officer, U.S. Patent and Trademark Office, U.S. Department of Commerce, P.O. Box 1450, Alexandria, Virginia 22313-1450. DO NOT SEND FEES OR COMPLETED FORMS TO THIS ADDRESS. SEND TO: Commissioner for Patents, P.O. Box 1450, Alexandria, Virginia 22313-1450.

Under the Paperwork Reduction Act of 1995, no persons are required to respond to a collection of information unless it displays a valid OMB control number.



UNITED STATES PATENT AND TRADEMARK OFFICE

UNITED STATES DEPARTMENT OF COMMERCE
United States Patent and Trademark Office
Address: COMMISSIONER FOR PATENTS
P.O. Box 1450
Alexandria, Virginia 22313-1450
www.uspto.gov

Table with columns: APPLICATION NO., FILING DATE, FIRST NAMED INVENTOR, ATTORNEY DOCKET NO., CONFIRMATION NO.
11/366,209 03/01/2006 Ammar Al-Ali MLR.004A 2025
20995 7590 03/12/2010
KNOBBE MARTENS OLSON & BEAR LLP
2040 MAIN STREET
FOURTEENTH FLOOR
IRVINE, CA 92614
EXAMINER: BERHANU, ETSUB D
ART UNIT: 3768 PAPER NUMBER
DATE MAILED: 03/12/2010

Determination of Patent Term Adjustment under 35 U.S.C. 154 (b)
(application filed on or after May 29, 2000)

The Patent Term Adjustment to date is 831 day(s). If the issue fee is paid on the date that is three months after the mailing date of this notice and the patent issues on the Tuesday before the date that is 28 weeks (six and a half months) after the mailing date of this notice, the Patent Term Adjustment will be 831 day(s).

If a Continued Prosecution Application (CPA) was filed in the above-identified application, the filing date that determines Patent Term Adjustment is the filing date of the most recent CPA.

Applicant will be able to obtain more detailed information by accessing the Patent Application Information Retrieval (PAIR) WEB site (http://pair.uspto.gov).

Any questions regarding the Patent Term Extension or Adjustment determination should be directed to the Office of Patent Legal Administration at (571)-272-7702. Questions relating to issue and publication fee payments should be directed to the Customer Service Center of the Office of Patent Publication at 1-(888)-786-0101 or (571)-272-4200.

Notice of Allowability	Application No.	Applicant(s)	
	11/366,209	AL-ALI ET AL.	
	Examiner	Art Unit	
	ETSUB D. BERHANU	3768	

-- The MAILING DATE of this communication appears on the cover sheet with the correspondence address--

All claims being allowable, PROSECUTION ON THE MERITS IS (OR REMAINS) CLOSED in this application. If not included herewith (or previously mailed), a Notice of Allowance (PTOL-85) or other appropriate communication will be mailed in due course. **THIS NOTICE OF ALLOWABILITY IS NOT A GRANT OF PATENT RIGHTS.** This application is subject to withdrawal from issue at the initiative of the Office or upon petition by the applicant. See 37 CFR 1.313 and MPEP 1308.

1. This communication is responsive to the amendments filed 23 October 2009.
2. The allowed claim(s) is/are 1-30.
3. Acknowledgment is made of a claim for foreign priority under 35 U.S.C. § 119(a)-(d) or (f).
 - a) All b) Some* c) None of the:
 1. Certified copies of the priority documents have been received.
 2. Certified copies of the priority documents have been received in Application No. _____.
 3. Copies of the certified copies of the priority documents have been received in this national stage application from the International Bureau (PCT Rule 17.2(a)).

* Certified copies not received: _____.

Applicant has THREE MONTHS FROM THE "MAILING DATE" of this communication to file a reply complying with the requirements noted below. Failure to timely comply will result in ABANDONMENT of this application.
THIS THREE-MONTH PERIOD IS NOT EXTENDABLE.

4. A SUBSTITUTE OATH OR DECLARATION must be submitted. Note the attached EXAMINER'S AMENDMENT or NOTICE OF INFORMAL PATENT APPLICATION (PTO-152) which gives reason(s) why the oath or declaration is deficient.
5. CORRECTED DRAWINGS (as "replacement sheets") must be submitted.
 - (a) including changes required by the Notice of Draftsperson's Patent Drawing Review (PTO-948) attached
 - 1) hereto or 2) to Paper No./Mail Date _____.
 - (b) including changes required by the attached Examiner's Amendment / Comment or in the Office action of Paper No./Mail Date _____.

Identifying indicia such as the application number (see 37 CFR 1.84(c)) should be written on the drawings in the front (not the back) of each sheet. Replacement sheet(s) should be labeled as such in the header according to 37 CFR 1.121(d).
6. DEPOSIT OF and/or INFORMATION about the deposit of BIOLOGICAL MATERIAL must be submitted. Note the attached Examiner's comment regarding REQUIREMENT FOR THE DEPOSIT OF BIOLOGICAL MATERIAL.

Attachment(s)

- | | |
|---|---|
| <ol style="list-style-type: none"> 1. <input type="checkbox"/> Notice of References Cited (PTO-892) 2. <input type="checkbox"/> Notice of Draftsperson's Patent Drawing Review (PTO-948) 3. <input type="checkbox"/> Information Disclosure Statements (PTO/SB/08), Paper No./Mail Date _____ 4. <input type="checkbox"/> Examiner's Comment Regarding Requirement for Deposit of Biological Material | <ol style="list-style-type: none"> 5. <input type="checkbox"/> Notice of Informal Patent Application 6. <input type="checkbox"/> Interview Summary (PTO-413), Paper No./Mail Date _____ . 7. <input checked="" type="checkbox"/> Examiner's Amendment/Comment 8. <input type="checkbox"/> Examiner's Statement of Reasons for Allowance 9. <input type="checkbox"/> Other _____. |
|---|---|

EXAMINER'S AMENDMENT

1. An examiner's amendment to the record appears below. Should the changes and/or additions be unacceptable to applicant, an amendment may be filed as provided by 37 CFR 1.312. To ensure consideration of such an amendment, it MUST be submitted no later than the payment of the issue fee.

Authorization for this examiner's amendment was given in a telephone interview with Mr. Jarom Kessler on 20 January 2010, wherein amendments to claims 9, 13 and 26 were discussed in order to clarify the intended invention.

The application has been amended as follows:

Claim 9 has been amended to read:

9. In a physiological sensor adapted to determine a physiological parameter using a plurality of light emitting sources with emission wavelengths affected by one or more dynamic operating parameters, a sensor method comprising:

providing a thermal mass disposed within the substrate proximate the light emitting sources and a temperature sensor thermally coupled to the thermal mass;

transmitting optical radiation from the plurality of light emitting sources into body tissue;

detecting the optical radiation after tissue attenuation; and

determining a plurality of operating wavelengths of the light emitting sources dependent on a bulk temperature of the light emitting sources so that one or more physiological parameters of a patient can be determined based upon the operating wavelengths.

Claim 12, line 2 has been amended to replace the term "theremistor" with the term - - thermistor - -.

Claim 13 has been amended to read:

Art Unit: 3768

13. In a physiological sensor adapted to determine a physiological parameter using a plurality of light emitting sources with emission wavelengths affected by one or more dynamic operating parameters, a sensor method comprising:

providing a thermal mass disposed within a substrate of the light emitting sources and a temperature sensor thermally coupled to the thermal mass;

transmitting optical radiation from the plurality of light emitting sources into body tissue;

detecting the optical radiation after tissue attenuation; and

indicating an operating wavelength for each of the plurality of light emitting sources.

Claim 25, line 1 has been amended to replace the term "21" with the term - - 24 - -.

Claim 26, line 4 has been amended to add the phrase - - and within a substrate - - between the terms "emitters" and "so".

Claim 30, line 2 has been amended to replace the phrase "a substrate" with the phrase - - the substrate - - in order to provide proper antecedent basis.

Any inquiry concerning this communication or earlier communications from the examiner should be directed to ETSUB D. BERHANU whose telephone number is (571)272-6563. The examiner can normally be reached on Monday - Friday (7:00 - 3:30).

If attempts to reach the examiner by telephone are unsuccessful, the examiner's supervisor, Long Le can be reached on (571)272-0823. The fax phone number for the organization where this application or proceeding is assigned is 571-273-8300.

Art Unit: 3768

Information regarding the status of an application may be obtained from the Patent Application Information Retrieval (PAIR) system. Status information for published applications may be obtained from either Private PAIR or Public PAIR. Status information for unpublished applications is available through Private PAIR only. For more information about the PAIR system, see <http://pair-direct.uspto.gov>. Should you have questions on access to the Private PAIR system, contact the Electronic Business Center (EBC) at 866-217-9197 (toll-free). If you would like assistance from a USPTO Customer Service Representative or access to the automated information system, call 800-786-9199 (IN USA OR CANADA) or 571-272-1000.

/Eric F Winakur/
Primary Examiner, Art Unit 3768

EDB

EAST Search History

EAST Search History (Prior Art)

Ref #	Hits	Search Query	DBs	Default Operator	Plurals	Time Stamp
L1	156470	"257"/\$.ccls. and thermal	US-PGPUB; USPAT; USOCR	OR	OFF	2010/01/21 15:37
L2	1797	"257"/\$.ccls. and thermal same temperature same bulk	US-PGPUB; USPAT; USOCR	OR	OFF	2010/01/21 15:37
L3	43	"257"/\$.ccls. and thermal same temperature same bulk same stabiliz\$4	US-PGPUB; USPAT; USOCR	OR	OFF	2010/01/21 15:38
L6	3	"372"/\$.ccls. and thermal same temperature same bulk same stabiliz\$4	US-PGPUB; USPAT; USOCR	OR	OFF	2010/01/21 15:54
L7	9	("20030026301" "20030048991" "5500916" "5959292" "5973824" "6078705" "6088147" "6212323" "6245412").PN. OR ("6782013").URPN.	US-PGPUB; USPAT; USOCR	OR	OFF	2010/01/21 15:55
L8	3	("2002/0154665").URPN.	USPAT	OR	OFF	2010/01/21 15:55
L9	604	(thermal and (substrate wafer) and (temperature thermistor) and (radiation emit\$4 source laser diode led) and wavelength).clm.	US-PGPUB	OR	ON	2010/01/21 15:57
L10	0	(thermal and (substrate wafer) and (temperature thermistor) and (radiation emit\$4 source laser diode led) and wavelength and bulk and stabliz\$4).clm.	US-PGPUB	OR	ON	2010/01/21 15:58
L11	12	(thermal and (substrate wafer) and (temperature thermistor) and (radiation emit\$4 source laser diode led) and wavelength and bulk).clm.	US-PGPUB	OR	ON	2010/01/21 15:58

L12	155	(thermal and (substrate wafer) and (temperature thermistor) and (radiation emit\$4 source laser diode led) and wavelength and (stabiliz\$4 equal\$4)).cm.	US-PGPUB	OR	ON	2010/01/21 15:58
L13	0	("2006/0211922").URPN.	USPAT	OR	OFF	2010/01/21 15:59
S1	141	"20010044700" "20010045532" "20020021269" "20020038078" "20020038081" "20020059047" "20020111748" "20020156353" "20020161291" "20020183819" "20030109775" "20030120160" "20030139657" "20030195402" "20040033618" "20040034898" "20040059209" "20040064259" "20040081621" "20040092805" "20040133087" "20040138538" "20040138540" "20040147823" "20040158134" "20040158135" "20040162472" "20040167382" "20040176670" "20040181134" "20040199063" "20040204639" "20040204868" "20040262046" "20040267103" "20040267140" "20050011488" "20050043902" "20050049469" "20050070773" "20050070775" "20050075546" "20050085735" "20050124871" "20050143634" "20050143943"	US-PGPUB; USPAT; USOCR	OR	OFF	2009/07/12 19:11

"20050148834" |
"20050184895" |
"20050187447" |
"20050187448" |
"20050187449" |
"20050187450" |
"20050187452" |
"20050187453" |
"20050197549" |
"20050197579" |
"20050197793" |
"20050203357" |
"20050228253" |
"20050250997" |
"20060030764" |
"3998550" | "0033643" |
"0036000" | "4157708" |
"4167331" | "4266554" |
"4446871" | "4586513" |
"4621643" | "4653498" |
"4685464" | "4694833" |
"4700708" | "4714341" |
"4770179" | "4773422" |
"4781195" | "4800885" |
"4832484" | "4846183" |
"4863265" | "4867571" |
"4869254" | "4907876" |
"4911167" | "4934372" |
"4942877" | "4955379" |
"4960126" | "4964010" |
"4967571" | "4975581" |
"4986665" | "4997769" |
"5033472" | "5054495" |
"5058588" | "5078136" |
"5190040" | "5209230" |
"5259381" | "5267562" |
"5267563" | "5278627" |
"5297548" | "5313940" |
"5331549" | "5335659" |
"5348004" | "5351685" |
"5355880" | "5355882" |
"5361758" | "5368224" |
"5385143" | "5387122" |
"5392777" | "5413101" |
"5421329" | "5427093" |
"5429128" | "5435309" |
"5490523" | "5494032" |
"5503148" | "5520177" |
"5533507" | "5551423" |
"5553615" | "5577500" |
"5584299" | "5588427" |
"5590652" | "5595176" |
"5596992" | "5603623" |
"5630413" | "5645059").
PN.

S2	200	("5645060" "5660567" "5662106" "5676139" "5676141" "5678544" "5685301" "5687719" "5687722" "5690104" "5692503" "5697371" "5713355" "5743263" "5746206" "5746697" "5752914" "5755226" "5772587" "5779630" "5782237" "5782756" "5790729" "5792052" "5793485" "5800348" "5800349" "5803910" "5807246" "5807247" "5810723" "5810724" "5817010" "5818985" "5823952" "5827182" "5830137" "5839439" "5842979" "5851178" "5851179" "5853364" "5857462" "5865736" "5876348" "5885213" "5891024" "5910108" "5916154" "5919133" "5921921" "5934277" "5954644" "5978691" "5983122" "5995856" "5995859" "5999841" "0555882" "6006119" "6014576" "6018673" "6018674" "6023541" "6064898" "6068594" "6073037" "6083172" "6094592" "6104938" "6112107" "6122042" "6151518" "6154667" "6157041" "6184521" "6226539" "6230035" "6253097" "6272363" "6285895" "6298252" "6304675" "6304767" "6330468" "6341257" "6351658" "6356774" "6363269" "6374129" "6377828" "6393310" "6397092" "6397093" "6408198" "6411833" "6415166" "6415233" "6415236" "6434408" "6441388" "6453184" "6463310" "6480729" "6490466" "6497659" "6501974" "6504943" "6505060" "6505061"	US-PGPUB; USPAT; USOCR	OR	OFF	2009/07/12 19:11
----	-----	--	------------------------------	----	-----	---------------------

		"6505133" "6510329" "6519486" "6522398" "6526301" "6528809" "6537225" "6546267" "6553241" "6564077" "6571113" "6582964" "6584413" "6591123" "6594511" "6600940" "6606509" "6606510" "6611698" "6614521" "6615064" "6615151" "6618602" "6622095" "6628975" "6631281" "6654623" "6657717" "6658277" "6662033" "6665551" "6668183" "6671526" "6675031" "6675106" "6681126" "6687620" "6694157" "6697655" "6701170" "6708049" "6711503" "6714803" "6714805" "6719705" "6720734" "6721584" "6725074" "6726634" "6741875" "6741876" "6743172" "6745061" "6748253" "6748254" "6754515" "6754516" "6760609" "6773397" "6778923" "6780158" "6788849" "6801797" "6801799" "6810277" "6819950" "6825619" "6829496" "6836679" "6839579" "6839580" "6839582" "6842702" "6845256" "6847835" "6869402" "6882874" "6912049" "6917422" "6919566" "6921367" "6922645" "6928311" "6931269" "6944487" "6975891" "6987994" "7001337" "7006856").PN.				
S3	2	kaestle.in. and resistor	US-PGPUB; USPAT; USOCR	OR	OFF	2009/07/12 19:12
S4	18	sakai.in. and wavelength with memory	US-PGPUB; USPAT; USOCR	OR	OFF	2009/07/12 19:12
S5	1	"20060211922"	US-PGPUB; USPAT; USOCR	OR	OFF	2009/07/12 19:16

S6	0	("2006/0211922").URPN.	USPAT	OR	OFF	2009/07/12 19:23
S7	21	S1 and temperature	USPAT	OR	OFF	2009/07/12 19:24
S8	68	S2 and temperature	USPAT	OR	OFF	2009/07/12 19:25
S9	40	S1 and temperature	US-PGPUB; USPAT; USOCR	OR	OFF	2009/07/12 19:25
S10	68	S2 and temperature	US-PGPUB; USPAT; USOCR	OR	OFF	2009/07/12 19:25
S11	1	"20060211922" and thermal adj mass	US-PGPUB; USPAT; USOCR	OR	OFF	2009/07/12 19:37
S12	1197	600/310.ccls.	US-PGPUB; USPAT; USOCR	OR	OFF	2009/07/12 20:41
S13	86	600/331.ccls.	US-PGPUB; USPAT; USOCR	OR	OFF	2009/07/12 20:41
S14	34	600/333.ccls.	US-PGPUB; USPAT; USOCR	OR	OFF	2009/07/12 20:41
S15	226	600/336.ccls.	US-PGPUB; USPAT; USOCR	OR	OFF	2009/07/12 20:42
S16	6213	stabiliz\$5 with temperature with (led diode source laser radiation emitter emitting)	US-PGPUB; USPAT; USOCR	OR	ON	2009/07/12 20:42
S17	294	stabiliz\$5 with temperature with (led diode source laser radiation emitter emitting) same thermistor	US-PGPUB; USPAT; USOCR	OR	ON	2009/07/12 20:43
S18	265	S17 and @py<"2006"	US-PGPUB; USPAT; USOCR	OR	ON	2009/07/12 20:43
S19	6	S18 and "600"/\$.ccls.	US-PGPUB; USPAT; USOCR	OR	ON	2009/07/12 20:57
S20	28	600/309-344.ccls. and wavelength with stabiliz\$5	US-PGPUB; USPAT; USOCR	OR	OFF	2009/07/12 21:09
S21	101	600/322.ccls. and laser with diodes	US-PGPUB; USPAT; USOCR	OR	OFF	2009/07/12 21:27

S22	77	S21 and @py<"2006"	US-PGPUB; USPAT; USOCR	OR	OFF	2009/07/12 21:27
S23	74	S21 and @py<"2005"	US-PGPUB; USPAT; USOCR	OR	OFF	2009/07/12 21:27
S24	105	600/323.ccls. and laser with diodes	US-PGPUB; USPAT; USOCR	OR	OFF	2009/07/12 21:29
S25	57	S24 and @py<"2004"	US-PGPUB; USPAT; USOCR	OR	OFF	2009/07/12 21:29
S26	115	600/322-344.ccls. and semiconductor with laser	US-PGPUB; USPAT; USOCR	OR	ON	2009/07/12 21:38
S27	51	S26 and @py<"2004"	US-PGPUB; USPAT; USOCR	OR	ON	2009/07/12 21:39
S28	100	peltier adj element same substrate same layer\$4	US-PGPUB; USPAT; USOCR	OR	OFF	2009/07/15 10:08
S29	0	peltier adj element with within with substrate same layer\$4	US-PGPUB; USPAT; USOCR	OR	OFF	2009/07/15 10:11
S30	11	peltier adj element with in with substrate same layer \$4	US-PGPUB; USPAT; USOCR	OR	OFF	2009/07/15 10:11
S31	9	peltier adj element with within with substrate	US-PGPUB; USPAT; USOCR	OR	OFF	2009/07/15 10:12
S32	24	S28 and copper	US-PGPUB; USPAT; USOCR	OR	OFF	2009/07/15 10:21
S33	0	peltier adj element with copper with cladding	US-PGPUB; USPAT; USOCR	OR	OFF	2009/07/15 10:23
S34	0	peltier adj element same (copper with cladding)	US-PGPUB; USPAT; USOCR	OR	OFF	2009/07/15 10:23
S35	0	peltier adj element same (copper with clad\$5)	US-PGPUB; USPAT; USOCR	OR	OFF	2009/07/15 10:23
S36	82	thermal with mass with within with substrate	US-PGPUB; USPAT; USOCR	OR	OFF	2009/12/18 10:51
S37	39	"5183042"	US-PGPUB; USPAT; USOCR	OR	OFF	2009/12/18 11:52

S38	0	"5183042.pn."	US-PGPUB; USPAT; USOCR	OR	OFF	2009/12/18 11:53
S39	1	"5183042".pn.	US-PGPUB; USPAT; USOCR	OR	OFF	2009/12/18 11:53
S40	473	compress with store with memory with data	US-PGPUB; USPAT; USOCR	OR	OFF	2009/12/18 13:57
S41	12	S40 and "600"/\$.cls.	US-PGPUB; USPAT; USOCR	OR	OFF	2009/12/18 13:57
S42	3590	compress\$4 with store with memory with data	US-PGPUB; USPAT; USOCR	OR	OFF	2009/12/18 14:01
S43	38	S42 and "600"/\$.cls.	US-PGPUB; USPAT; USOCR	OR	OFF	2009/12/18 14:01

1 / 21 / 2010 4:04:15 PM

C:\ Documents and Settings\ eberhanu\ My Documents\ EAST\ Workspaces\ 11366209.wsp

<i>Index of Claims</i> 	Application/Control No. 11366209	Applicant(s)/Patent Under Reexamination AL-ALI ET AL.
	Examiner ETSUB D BERHANU	Art Unit 3768

✓	Rejected
=	Allowed

-	Cancelled
÷	Restricted

N	Non-Elected
I	Interference

A	Appeal
O	Objected

Claims renumbered in the same order as presented by applicant
 CPA
 T.D.
 R.1.47

CLAIM		DATE									
Final	Original										
1	1	=									
2	2	=									
3	3	=									
4	4	=									
7	5	=									
8	6	=									
9	7	=									
10	8	=									
13	9	=									
14	10	=									
15	11	=									
16	12	=									
20	13	=									
21	14	=									
22	15	=									
6	16	=									
5	17	=									
11	18	=									
12	19	=									
17	20	=									
18	21	=									
19	22	=									
23	23	=									
24	24	=									
25	25	=									
26	26	=									
27	27	=									
28	28	=									
29	29	=									
30	30	=									

Issue Classification 	Application/Control No. 11366209	Applicant(s)/Patent Under Reexamination AL-ALI ET AL.
	Examiner ETSUB D BERHANU	Art Unit 3768

ORIGINAL						INTERNATIONAL CLASSIFICATION														
CLASS		SUBCLASS				CLAIMED					NON-CLAIMED									
600		310				A	6	1	B	5 / 145 (2006.01.01)										
CROSS REFERENCE(S)																				
CLASS	SUBCLASS (ONE SUBCLASS PER BLOCK)																			
362	84																			

Claims renumbered in the same order as presented by applicant
 CPA
 T.D.
 R.1.47

Final	Original	Final	Original	Final	Original	Final	Original	Final	Original	Final	Original	Final	Original	Final	Original
1	1	5	17												
2	2	11	18												
3	3	12	19												
4	4	17	20												
7	5	18	21												
8	6	19	22												
9	7	23	23												
10	8	24	24												
13	9	25	25												
14	10	26	26												
15	11	27	27												
16	12	28	28												
20	13	29	29												
21	14	30	30												
22	15														
6	16														

/ETSUB D BERHANU/ Examiner.Art Unit 3768 (Assistant Examiner)	01/21/2010 (Date)	Total Claims Allowed: 30	
/Eric F Winakur/ Primary Examiner.Art Unit 3768 (Primary Examiner)	01/28/2010 (Date)	O.G. Print Claim(s) 13	O.G. Print Figure 12

Search Notes 	Application/Control No. 11366209	Applicant(s)/Patent Under Reexamination AL-ALI ET AL.
	Examiner ETSUB D BERHANU	Art Unit 3768

SEARCHED			
Class	Subclass	Date	Examiner
600	310, 331, 333, 336	01/21/2010	EDB

SEARCH NOTES		
Search Notes	Date	Examiner
Searched EAST (USPAT, USPGPUB)	01/21/2010	EDB
Class/subclass search and Keyword search	01/21/2010	EDB
PALM Inventor Name Search	01/21/2010	EDB
See Attached Sheets	01/21/2010	EDB

INTERFERENCE SEARCH			
Class	Subclass	Date	Examiner
PGPUB	See Search History	01/21/2010	EDB

--	--



UNITED STATES PATENT AND TRADEMARK OFFICE

UNITED STATES DEPARTMENT OF COMMERCE
United States Patent and Trademark Office
Address: COMMISSIONER FOR PATENTS
P.O. Box 1450
Alexandria, Virginia 22313-1450
www.uspto.gov

Table with columns: APPLICATION NO., FILING DATE, FIRST NAMED INVENTOR, ATTORNEY DOCKET NO., CONFIRMATION NO., EXAMINER, ART UNIT, PAPER NUMBER, NOTIFICATION DATE, DELIVERY MODE. Includes application details for Ammar Al-Ali and examiner BERHANU, ETSUB D.

Please find below and/or attached an Office communication concerning this application or proceeding.

The time period for reply, if any, is set in the attached communication.

Notice of the Office communication was sent electronically on above-indicated "Notification Date" to the following e-mail address(es):

jcartec@kmob.com
eOAPilot@kmob.com

Interview Summary	Application No.	Applicant(s)	
	11/366,209	AL-ALI ET AL.	
	Examiner	Art Unit	
	ETSUB D. BERHANU	3768	

All participants (applicant, applicant's representative, PTO personnel):

- (1) ETSUB D. BERHANU. (3) Jarom Kesler.
(2) Eric Winakur. (4) Sean Ambrosius.

Date of Interview: 20 October 2009.

Type: a) Telephonic b) Video Conference
c) Personal [copy given to: 1) applicant 2) applicant's representative]

Exhibit shown or demonstration conducted: d) Yes e) No.
If Yes, brief description: _____.

Claim(s) discussed: 1,5,9 and 13.

Identification of prior art discussed: prior art of record.

Agreement with respect to the claims f) was reached. g) was not reached. h) N/A.

Substance of Interview including description of the general nature of what was agreed to if an agreement was reached, or any other comments: Applicant provided proposed amendments to the claims. Applicant and Examiner discussed the proposed amendments as they related to the cited prior art. Examiner will update their search once a reply is filed by the Applicant.

(A fuller description, if necessary, and a copy of the amendments which the examiner agreed would render the claims allowable, if available, must be attached. Also, where no copy of the amendments that would render the claims allowable is available, a summary thereof must be attached.)

THE FORMAL WRITTEN REPLY TO THE LAST OFFICE ACTION MUST INCLUDE THE SUBSTANCE OF THE INTERVIEW. (See MPEP Section 713.04). If a reply to the last Office action has already been filed, APPLICANT IS GIVEN A NON-EXTENDABLE PERIOD OF THE LONGER OF ONE MONTH OR THIRTY DAYS FROM THIS INTERVIEW DATE, OR THE MAILING DATE OF THIS INTERVIEW SUMMARY FORM, WHICHEVER IS LATER, TO FILE A STATEMENT OF THE SUBSTANCE OF THE INTERVIEW. See Summary of Record of Interview requirements on reverse side or on attached sheet.

/Eric F Winakur/
Primary Examiner, Art Unit 3768

Summary of Record of Interview Requirements

Manual of Patent Examining Procedure (MPEP), Section 713.04, Substance of Interview Must be Made of Record

A complete written statement as to the substance of any face-to-face, video conference, or telephone interview with regard to an application must be made of record in the application whether or not an agreement with the examiner was reached at the interview.

Title 37 Code of Federal Regulations (CFR) § 1.133 Interviews Paragraph (b)

In every instance where reconsideration is requested in view of an interview with an examiner, a complete written statement of the reasons presented at the interview as warranting favorable action must be filed by the applicant. An interview does not remove the necessity for reply to Office action as specified in §§ 1.111, 1.135. (35 U.S.C. 132)

37 CFR §1.2 Business to be transacted in writing.

All business with the Patent or Trademark Office should be transacted in writing. The personal attendance of applicants or their attorneys or agents at the Patent and Trademark Office is unnecessary. The action of the Patent and Trademark Office will be based exclusively on the written record in the Office. No attention will be paid to any alleged oral promise, stipulation, or understanding in relation to which there is disagreement or doubt.

The action of the Patent and Trademark Office cannot be based exclusively on the written record in the Office if that record is itself incomplete through the failure to record the substance of interviews.

It is the responsibility of the applicant or the attorney or agent to make the substance of an interview of record in the application file, unless the examiner indicates he or she will do so. It is the examiner's responsibility to see that such a record is made and to correct material inaccuracies which bear directly on the question of patentability.

Examiners must complete an Interview Summary Form for each interview held where a matter of substance has been discussed during the interview by checking the appropriate boxes and filling in the blanks. Discussions regarding only procedural matters, directed solely to restriction requirements for which interview recordation is otherwise provided for in Section 812.01 of the Manual of Patent Examining Procedure, or pointing out typographical errors or unreadable script in Office actions or the like, are excluded from the interview recordation procedures below. Where the substance of an interview is completely recorded in an Examiners Amendment, no separate Interview Summary Record is required.

The Interview Summary Form shall be given an appropriate Paper No., placed in the right hand portion of the file, and listed on the "Contents" section of the file wrapper. In a personal interview, a duplicate of the Form is given to the applicant (or attorney or agent) at the conclusion of the interview. In the case of a telephone or video-conference interview, the copy is mailed to the applicant's correspondence address either with or prior to the next official communication. If additional correspondence from the examiner is not likely before an allowance or if other circumstances dictate, the Form should be mailed promptly after the interview rather than with the next official communication.

The Form provides for recordation of the following information:

- Application Number (Series Code and Serial Number)
- Name of applicant
- Name of examiner
- Date of interview
- Type of interview (telephonic, video-conference, or personal)
- Name of participant(s) (applicant, attorney or agent, examiner, other PTO personnel, etc.)
- An indication whether or not an exhibit was shown or a demonstration conducted
- An identification of the specific prior art discussed
- An indication whether an agreement was reached and if so, a description of the general nature of the agreement (may be by attachment of a copy of amendments or claims agreed as being allowable). Note: Agreement as to allowability is tentative and does not restrict further action by the examiner to the contrary.
- The signature of the examiner who conducted the interview (if Form is not an attachment to a signed Office action)

It is desirable that the examiner orally remind the applicant of his or her obligation to record the substance of the interview of each case. It should be noted, however, that the Interview Summary Form will not normally be considered a complete and proper recordation of the interview unless it includes, or is supplemented by the applicant or the examiner to include, all of the applicable items required below concerning the substance of the interview.

A complete and proper recordation of the substance of any interview should include at least the following applicable items:

- 1) A brief description of the nature of any exhibit shown or any demonstration conducted,
- 2) an identification of the claims discussed,
- 3) an identification of the specific prior art discussed,
- 4) an identification of the principal proposed amendments of a substantive nature discussed, unless these are already described on the Interview Summary Form completed by the Examiner,
- 5) a brief identification of the general thrust of the principal arguments presented to the examiner,
(The identification of arguments need not be lengthy or elaborate. A verbatim or highly detailed description of the arguments is not required. The identification of the arguments is sufficient if the general nature or thrust of the principal arguments made to the examiner can be understood in the context of the application file. Of course, the applicant may desire to emphasize and fully describe those arguments which he or she feels were or might be persuasive to the examiner.)
- 6) a general indication of any other pertinent matters discussed, and
- 7) if appropriate, the general results or outcome of the interview unless already described in the Interview Summary Form completed by the examiner.

Examiners are expected to carefully review the applicant's record of the substance of an interview. If the record is not complete and accurate, the examiner will give the applicant an extendable one month time period to correct the record.

Examiner to Check for Accuracy

If the claims are allowable for other reasons of record, the examiner should send a letter setting forth the examiner's version of the statement attributed to him or her. If the record is complete and accurate, the examiner should place the indication, "Interview Record OK" on the paper recording the substance of the interview along with the date and the examiner's initials.

MLR.004A

PATENT

IN THE UNITED STATES PATENT AND TRADEMARK OFFICE

Applicant : Ammar Al-Ali et al.
App. No : 11/366,209
Filed : March 1, 2006
For : MULTIPLE WAVELENGTH SENSOR
SUBSTRATE
Examiner : Etsub D. Berhanu
Art Unit : 3768
Conf No. : 2025

CERTIFICATE OF EFS WEB
TRANSMISSION

I hereby certify that this correspondence, and any other attachment noted on the automated Acknowledgement Receipt, is being transmitted from within the Pacific Time zone to the Commissioner for Patents via the EFS Web server on:

October 23, 2009

(Date)

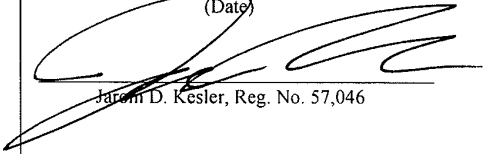
Jaron D. Kesler, Reg. No. 57,046

RESPONSE TO OFFICE ACTION DATED JULY 23, 2009

Mail Stop Amendment

Commissioner for Patents
P.O. Box 1450
Alexandria, VA 22313-1450

Dear Sir:

In response to the Office Action dated July 23, 2009, Applicants respectfully submit the following comments in connection with the above-captioned application.

Amendments to the Claims are reflected in the listing of claims which begins on page 2 of this paper.

Summary of Interview begins on page 6 of this paper.

Remarks/Arguments begin on page 7 of this paper.

Application No.: 11/366,209
Filing Date: March 1, 2006

AMENDMENTS TO THE CLAIMS

1. **(Currently Amended)** A physiological sensor comprising:
a plurality of emitters configured to transmit optical radiation having a plurality of wavelengths in response to a corresponding plurality of drive currents, the plurality of emitters including a substrate;
a thermal mass disposed proximate the emitters and within the substrate so as to stabilize a bulk temperature for the emitters; and
a temperature sensor thermally coupled to the thermal mass,
wherein the temperature sensor provides a temperature sensor output responsive to the bulk temperature so that the wavelengths are determinable as a function of the drive currents and the bulk temperature.
2. **(Currently Amended)** The physiological sensor according to claim 1 wherein the ~~further comprising a substrate~~ has ~~having~~ a first side and a second side,
wherein the emitters are mounted to the first side, and
wherein the temperature sensor is mounted to the second side.
3. **(Original)** The physiological sensor according to claim 2 wherein the temperature sensor is a thermistor and the emitters are LEDs.
4. **(Currently Amended)** The physiological sensor according to claim 3:
wherein the thermal mass is a plurality of layers of the substrate, ~~and~~
~~wherein each of the layers is substantially copper clad.~~
5. **(Currently Amended)** A physiological sensor capable of emitting light into tissue and producing an output signal usable to determine one or more physiological parameters of a patient, the physiological sensor comprising:
a thermal mass;
a plurality of light emitting sources, including a substrate of the plurality of light emitting sources, thermally coupled to the thermal mass, the sources having a corresponding plurality of operating wavelengths, the thermal mass disposed within the substrate;
a temperature sensor thermally coupled to the thermal mass and capable of determining a bulk temperature for the thermal mass, the operating wavelengths dependent on the bulk temperature; and

Application No.: 11/366,209
Filing Date: March 1, 2006

a detector capable of detecting light emitted by the light emitting sources after tissue attenuation, wherein the detector is capable of outputting a signal usable to determine one or more physiological parameters of a patient based upon the operating wavelengths.

6. **(Currently Amended)** The physiological sensor according to claim 5:

~~wherein the light emitting sources and the temperature sensor are disposed on a substrate,~~
and

wherein the thermal mass is disposed within the substrate proximate the light emitting sources and the temperature sensor.

7. **(Currently Amended)** The physiological sensor according to claim 6 5 wherein the temperature sensor comprises a thermistor.

8. **(Original)** The physiological sensor according to claim 7 wherein the light emitting sources are disposed on a first side of the substrate and the temperature sensor is disposed on a second side of the substrate.

9. **(Currently Amended)** In a physiological sensor adapted to determine a physiological parameter using a plurality of light emitting sources with emission wavelengths affected by one or more dynamic operating parameters, a sensor method comprising:

providing a thermal mass disposed within a substrate proximate the light emitting sources;

transmitting optical radiation from the plurality of light emitting sources into body tissue;
detecting the optical radiation after tissue attenuation; and

determining a plurality of operating wavelengths of the light emitting sources dependent on a bulk temperature of the light emitting sources so that one or more physiological parameters of a patient can be determined based upon the operating wavelengths.

10. **(Original)** The physiological sensor method according to claim 9 wherein the determining step comprises stabilizing the bulk temperature for the light emitting sources.

11. **(Original)** The physiological sensor method according to claim 10 wherein the determining further comprises thermally coupling a thermistor to the light emitting sources so as to indicate the bulk temperature.

Application No.: 11/366,209
Filing Date: March 1, 2006

12. **(Original)** The physiological sensor method according to claim 11 further comprising disposing the thermistor proximate the light emitting sources.

13. **(Currently Amended)** In a physiological sensor adapted to determine a physiological parameter using a plurality of light emitting sources with emission wavelengths affected by one or more dynamic operating parameters, a sensor method comprising:

providing a thermal mass disposed within a substrate of the light emitting sources;

transmitting optical radiation from the plurality of light emitting sources into body tissue;

detecting the optical radiation after tissue attenuation; and

indicating an operating wavelength for each of the plurality of light emitting sources.

14. **(Original)** The physiological sensor method according to claim 13 wherein the indicating step comprises measuring a bulk temperature for the light emitting sources.

15. **(Original)** The physiological sensor method according to claim 14 wherein the indicating further comprises utilizing a thermistor thermally coupled to the light emitting sources so as to measure a bulk temperature.

16. **(New)** The physiological sensor according to claim 1:

wherein the thermal mass is disposed within the substrate proximate the light emitting sources and the temperature sensor.

17. **(New)** The physiological sensor of claim 4 wherein each of the layers of the thermal mass is substantially copper clad

18. **(New)** The physiological sensor according to claim 5 wherein the thermal mass is a plurality of layers of the substrate.

19. **(New)** The physiological sensor of claim 18 wherein each of the layers of the thermal mass is substantially copper clad.

20. **(New)** The physiological sensor according to claim 9 wherein the thermal mass is disposed within the substrate proximate the light emitting sources and the temperature sensor.

21. **(New)** The physiological sensor method according to claim 9 wherein the thermal mass is a plurality of layers of the substrate.

22. **(New)** The physiological sensor method according to claim 21 wherein each of the layers of the thermal mass is substantially copper clad.

Application No.: 11/366,209
Filing Date: March 1, 2006

23. (New) The physiological sensor according to claim 13 wherein the thermal mass is disposed within the substrate proximate the light emitting sources and the temperature sensor.

24. (New) The physiological sensor method according to claim 13 wherein the thermal mass is a plurality of layers of the substrate.

25. (New) The physiological sensor method according to claim 21 wherein each of the layers of the thermal mass is substantially copper clad.

26. (New) A physiological sensor comprising:
a plurality of emitters configured to transmit optical radiation having a plurality of wavelengths in response to a corresponding plurality of drive currents;
a thermal mass disposed proximate the emitters so as to stabilize a bulk temperature for the emitters; and
a temperature sensor thermally coupled to the thermal mass,
wherein the temperature sensor provides a temperature sensor output responsive to the bulk temperature so that the wavelengths are determinable as a function of the drive currents and the bulk temperature;

a substrate having a top side and a bottom side,
wherein the emitters are mounted to the top side, and
wherein the temperature sensor is mounted to the bottom side.

27. (New) The physiological sensor according to claim 26 wherein the temperature sensor is a thermistor and the emitters are LEDs.

28. (New) The physiological sensor according to claim 26 wherein the thermal mass is a plurality of layers of the substrate.

29. (New) The physiological sensor of claim 28 wherein each of the layers of the thermal mass is substantially copper clad.

30. (New) The physiological sensor according to claim 26:
wherein the light emitting sources and the temperature sensor are disposed on a substrate,
and
wherein the thermal mass is disposed within the substrate proximate the light emitting sources and the temperature sensor.

Application No.: 11/366,209
Filing Date: March 1, 2006

SUMMARY OF INTERVIEW

An in-person interview was conducted on October 20, 2009 between Applicants counsel of record, Jarom D. Kesler, reg. no. 57,046 and Sean Ambrosius, reg. no. 65,290 and Examiners Winakur and Berhanu. Applicants discussed the pending claims and the cited references. Applicants proposed amendments to the claims.

Application No.: 11/366,209
Filing Date: March 1, 2006

REMARKS

The Applicants thank the Examiner for their examination of the present application. By way of summary, Claims 1-15 were pending. In the present amendment, Applicants have amended Claims 1, 2, 4, 5, 6, 7, 9, 13; and added new Claims 16-30. Accordingly, Claims 1-30 remain pending for consideration.

Applicants note that in the Disposition of the Claims section of the July, 23, 2009 Office Action, the Office Action indicated that only Claims 1-12 were pending. The Applicants respectfully note that this appears to be a typographical error.

The Applicants would like to thank Examiners Berhanu and Winakur for the interview extended to the Applicants' counsel of record, Jarom D. Kesler and Sean Ambrosius. During the interview, the claims were discussed in light of the prior art and Applicants presented proposed amendments. Accordingly, the Applicants have amended Claims 1, 2, 4, 5, 6, 7, 9, 13 along the lines discussed in the interview. Therefore, the Applicants respectfully request reconsideration of the pending amended claims.

Allowable Subject Matter - Claims 4, and 6-8

The Applicants also thank the Examiner for the indication of allowable subject matter in Claims 4, and 6-8. Pursuant to the Office Action, the Applicants have revised the claims to include the subject matter indicated as allowable. Accordingly, the Applicants respectfully submit that Claims as amended are in condition for allowance.

Examiner's Statement of Reasons for Allowance

The Applicants respectfully disagree with the Examiner's Statement of Reasons for Allowance to the extent that not all the claims include each of the structures or method steps recited in the Examiner's Statement. Also, the Applicants respectfully disagree with the Examiner's Statement to the extent that there is any implication that the patentability of any claim rests on the recitation of a single feature because it is the combination of features recited in each claim that makes that claim patentable.

Application No.: 11/366,209
Filing Date: March 1, 2006

Rejection of Claims 9, 13 and 14 Under 35 U.S.C. § 102(b)

The Office Action rejected Claims 9, 13 and 14 under 35 U.S.C. § 102(b) as being anticipated by Cheung et al. '381 (USPN 5,259,381).

The Applicants respectfully submit that the claims as previously pending are patentably distinguished over the Cheung patent, the other cited references, or any combination thereof. Claims 9 and 13, however, have been amended to include the subject matter indicated as allowable in the July 23, 2009 Office Action in order to advance prosecution of the present application. Applicants respectfully assert that Claims 9 and 13 are in condition for allowance and respectfully request such action.

Claim 14 which depends from Claim 13, is believed to be patentable for the same reasons articulated above with respect to Claim 13, and because of the additional features recited therein.

Rejection of Claim 15 Under 35 U.S.C. § 103(a)

The Office Action rejected Claim 15 under 35 U.S.C. § 103(a) as being unpatentable over Cheung et al. '381, as applied to claim 14, further in view of Funabashi et al. '665 (US Pub No. 2002/0154665).

Claim 15 which depends from Claim 13, is believed to be patentable for the same reasons articulated above with respect to Claim 13, and because of the additional features recited therein.

Rejection of Claims 1-3 and 5 under 35 U.S.C. § 103(a)

The Office Action rejected Claims 1-3 and 5 under 35 U.S.C. § 103(a) as being unpatentable over Cheung et al. '381 further in view of Dettling '113 (USPN 6,360,113) further in view of Funabashi et al. '665.

The Applicants respectfully submit that the claims as previously pending are patentably distinguished over the Cheung patent, the Dettling patent, the other cited references, or any combination thereof. Claim 1, however, has been amended to include the subject matter indicated as allowable in the July 23, 2009 Office Action in order to advance prosecution of the present application. Applicants respectfully assert that Claim 1 is in condition for allowance and respectfully request such action.

Application No.: 11/366,209
Filing Date: March 1, 2006

Claims 2-3 and 5 which depend from Claim 1, are believed to be patentable for the same reasons articulated above with respect to Claim 1, and because of the additional features recited therein.

Rejection of Claims 9-12 Under 35 U.S.C. § 103(a)

The Office Action rejected Claims 9-12 under 35 U.S.C. § 103(a) as being unpatentable over Noda et al. '588 (USPN 6,149,588) further in view of Dettling '113 further in view of Funabashi et al '665 further in view of Cheung et al. '381.

The Applicants respectfully submit that the claims as previously pending are patentably distinguished over the Noda patent, the Dettling patent, the Funabashi patent, the other cited references, or any combination thereof. Claim 9, however, has been amended to include the subject matter indicated as allowable in the July 23, 2009 Office Action in order to advance prosecution of the present application. Applicants respectfully assert that Claim 9 is in condition for allowance and respectfully request such action.

Claims 10-12 which depend from Claim 9, are believed to be patentable for the same reasons articulated above with respect to Claim 9, and because of the additional features recited therein.

No Disclaimers or Disavowals

Although the present communication may include alterations to the application or claims, or characterizations of claim scope or referenced art, Applicants are not conceding in this application that previously pending claims are not patentable over the cited references. Rather, any alterations or characterizations are being made to facilitate expeditious prosecution of this application. Applicants reserve the right to pursue at a later date any previously pending or other broader or narrower claims that capture any subject matter supported by the present disclosure, including subject matter found to be specifically disclaimed herein or by any prior prosecution. Accordingly, reviewers of this or any parent, child or related prosecution history shall not reasonably infer that Applicants have made any disclaimers or disavowals of any subject matter supported by the present application.

Application No.: 11/366,209
Filing Date: March 1, 2006

Co-Pending Applications of Assignee

Applicants wish to draw the Examiner's attention to the following co-pending applications of the present application's assignee.

Docket No.	Serial No.	title	Filed
MLR.002A	11/367013	Multiple Wavelength Sensor Emitters	03/01/06
MLR.002C1	12/422915	Multiple Wavelength Sensor Emitters	04/13/09
MLR.002CP1	11/546932	Disposable Multiple Wavelength Optical Sensor	10/12/06
MLR.003A	11/366995	Multiple Wavelength Sensor Equalization	05/01/06
MLR.006C1	12/568469	Multiple Wavelength Sensor Emitters	09/28/09
MLR.009A	11/366997	Multiple Wavelength Sensor Drivers	03/01/06
MLR.010A	11/367034	Physiological Parameter Confidence Measure	03/01/06
MLR.011A	11/367036	Configurable Physiological Measurement System	03/01/06
MLR.012A	11/367033	Noninvasive Multi-Parameter Patient Monitor	03/01/06
MLR.013A	11/367014	Noninvasive Multi-Parameter Patient Monitor	03/01/06
MLR.014A	11/366208	Noninvasive Multi-Parameter Patient Monitor	03/01/06
MLR.015A	12/056179	Multiple Wavelength Optical Sensor	03/26/08
MLR.015A2	12/082810	Optical Sensor Assembly	04/14/08
MLRNP.002A	11/367017	noninvasive multi-parameter patient monitor	03/01/06
MLRNP.003A	11/871646	Noninvasive Multi-Parameter Patient Monitor	10/12/07
MLRNP.005A	11/963599	Noninvasive Multi-Parameter Patient Monitor	12/21/07
MLRNP.006A	11/366214	Resonant Cavity Light Emitting Diode For Use In Patient Monitor	03/01/06
MLRNP.007A	12/110214	Noninvasive Multi-Parameter Patient Monitor	04/25/08

Application No.: 11/366,209
Filing Date: March 1, 2006

Please charge any additional fees, including any fees for additional extension of time, or credit overpayment to Deposit Account No. 11-1410.

Respectfully submitted,

KNOBBE, MARTENS, OLSON & BEAR, LLP

Dated: October 23, 2009

By: 

Jarom D. Kesler
Registration No. 57,046
Attorney of Record
Customer No. 20995
(949) 760-0404

7994285
102209

Electronic Patent Application Fee Transmittal				
Application Number:	11366209			
Filing Date:	01-Mar-2006			
Title of Invention:	Multiple wavelength sensor substrate			
First Named Inventor/Applicant Name:	Ammar Al-Ali			
Filer:	Jarom D. Kesler/Nadin Hamoui			
Attorney Docket Number:	MLR.004A			
Filed as Large Entity				
Utility under 35 USC 111(a) Filing Fees				
Description	Fee Code	Quantity	Amount	Sub-Total in USD(\$)
Basic Filing:				
Pages:				
Claims:				
Claims in excess of 20	1202	10	52	520
Independent claims in excess of 3	1201	1	220	220
Miscellaneous-Filing:				
Petition:				
Patent-Appeals-and-Interference:				
Post-Allowance-and-Post-Issuance:				

Description	Fee Code	Quantity	Amount	Sub-Total in USD(\$)
Extension-of-Time:				
Miscellaneous:				
Total in USD (\$)				740

Electronic Acknowledgement Receipt

EFS ID:	6324281
Application Number:	11366209
International Application Number:	
Confirmation Number:	2025
Title of Invention:	Multiple wavelength sensor substrate
First Named Inventor/Applicant Name:	Ammar Al-Ali
Customer Number:	20995
Filer:	Jarom D. Kesler/ThuyQuyen Nguyen
Filer Authorized By:	Jarom D. Kesler
Attorney Docket Number:	MLR.004A
Receipt Date:	23-OCT-2009
Filing Date:	01-MAR-2006
Time Stamp:	19:44:33
Application Type:	Utility under 35 USC 111(a)

Payment information:

Submitted with Payment	yes
Payment Type	Credit Card
Payment was successfully received in RAM	\$740
RAM confirmation Number	5109
Deposit Account	111410
Authorized User	KNOBBE MARTENS OLSON AND BEAR

The Director of the USPTO is hereby authorized to charge indicated fees and credit any overpayment as follows:

Charge any Additional Fees required under 37 C.F.R. Section 1.16 (National application filing, search, and examination fees)

Charge any Additional Fees required under 37 C.F.R. Section 1.17 (Patent application and reexamination processing fees)

File Listing:					
Document Number	Document Description	File Name	File Size(Bytes)/ Message Digest	Multi Part /.zip	Pages (if appl.)
1		MLR.pdf	532546 633d288220cdbcdfcac697dfe04434411b9d47d	yes	11
Multipart Description/PDF files in .zip description					
	Document Description		Start		End
	Amendment/Req. Reconsideration-After Non-Final Reject		1		1
	Claims		2		5
	Applicant summary of interview with examiner		6		6
	Applicant Arguments/Remarks Made in an Amendment		7		11
Warnings:					
Information:					
2	Fee Worksheet (PTO-875)	fee-info.pdf	31497 0153c8f31b49debbe12da0f36104d49a4026b6f1	no	2
Warnings:					
Information:					
Total Files Size (in bytes):			564043		
<p>This Acknowledgement Receipt evidences receipt on the noted date by the USPTO of the indicated documents, characterized by the applicant, and including page counts, where applicable. It serves as evidence of receipt similar to a Post Card, as described in MPEP 503.</p> <p><u>New Applications Under 35 U.S.C. 111</u> If a new application is being filed and the application includes the necessary components for a filing date (see 37 CFR 1.53(b)-(d) and MPEP 506), a Filing Receipt (37 CFR 1.54) will be issued in due course and the date shown on this Acknowledgement Receipt will establish the filing date of the application.</p> <p><u>National Stage of an International Application under 35 U.S.C. 371</u> If a timely submission to enter the national stage of an international application is compliant with the conditions of 35 U.S.C. 371 and other applicable requirements a Form PCT/DO/EO/903 indicating acceptance of the application as a national stage submission under 35 U.S.C. 371 will be issued in addition to the Filing Receipt, in due course.</p> <p><u>New International Application Filed with the USPTO as a Receiving Office</u> If a new international application is being filed and the international application includes the necessary components for an international filing date (see PCT Article 11 and MPEP 1810), a Notification of the International Application Number and of the International Filing Date (Form PCT/RO/105) will be issued in due course, subject to prescriptions concerning national security, and the date shown on this Acknowledgement Receipt will establish the international filing date of the application.</p>					



UNITED STATES PATENT AND TRADEMARK OFFICE

UNITED STATES DEPARTMENT OF COMMERCE
United States Patent and Trademark Office
Address: COMMISSIONER FOR PATENTS
P.O. Box 1450
Alexandria, Virginia 22313-1450
www.uspto.gov

Table with 5 columns: APPLICATION NO., FILING DATE, FIRST NAMED INVENTOR, ATTORNEY DOCKET NO., CONFIRMATION NO. Includes details for application 11/366,209 filed 03/01/2006 by Ammar Al-Ali, attorney MLR.004A, confirmation 2025, examiner BERHANU, ETSUB D, art unit 3768, notification date 07/23/2009, and delivery mode ELECTRONIC.

Please find below and/or attached an Office communication concerning this application or proceeding.

The time period for reply, if any, is set in the attached communication.

Notice of the Office communication was sent electronically on above-indicated "Notification Date" to the following e-mail address(es):

jcartec@kmob.com
eOAPilot@kmob.com

DETAILED ACTION

Claim Rejections - 35 USC § 102

1. The following is a quotation of the appropriate paragraphs of 35 U.S.C. 102 that form the basis for the rejections under this section made in this Office action:

A person shall be entitled to a patent unless –

(b) the invention was patented or described in a printed publication in this or a foreign country or in public use or on sale in this country, more than one year prior to the date of application for patent in the United States.

2. Claims 9, 13 and 14 are rejected under 35 U.S.C. 102(b) as being anticipated by Cheung et al.'381 (cited by Applicant).

Cheung et al.'381 discloses a sensor method, the method comprising: transmitting optical radiation from a plurality of light emitting sources into body tissue, detecting the optical radiation after tissue attenuation and determining a plurality of operating wavelengths of the light emitting sources so that one or more physiological parameters can be determined based upon the operating wavelengths (see ABSTRACT and SUMMARY OF THE INVENTION). Figure 11 and its description thereof disclose a physiological sensor used to carry out the method discussed above, the apparatus comprising a plurality of LED emitters 40,42 and a temperature sensor 50, the emitters mounted on a first left side of a substrate and the temperature sensor mounted on a second right side of the substrate.

Claim Rejections - 35 USC § 103

3. The following is a quotation of 35 U.S.C. 103(a) which forms the basis for all obviousness rejections set forth in this Office action:

(a) A patent may not be obtained though the invention is not identically disclosed or described as set forth in section 102 of this title, if the differences between the subject matter sought to be patented and the prior art are such that the subject matter as a whole would have been obvious at the time the invention was made to a person having ordinary skill in the art to which said subject matter pertains. Patentability shall not be negated by the manner in which the invention was made.

Art Unit: 3768

4. Claim 15 is rejected under 35 U.S.C. 103(a) as being unpatentable over Cheung et al.'381, as applied to claim 14, further in view of Funabashi et al.'665 (US Pub No. 2002/0154665).

Cheung et al.'381 discloses all the elements of the current invention, as discussed in paragraph 2 above, except for the method comprising utilizing a thermistor thermally coupled to the light emitting sources to measure the bulk temperature. Cheung et al.'381 discloses the use of a temperature sensor, but fails to give the details of the temperature sensor. Funabashi et al.'665 teaches the use of a thermistor thermally connected to a light source to measure the temperature of the light source (page 9, section [0079]). It would have been within the skill of the art to use a thermistor, such as the one discussed in Funabashi et al.'665, as the temperature sensor of Cheung et al.'381 since Cheung et al.'381 requires the use of a temperature sensor for measuring the temperature of light sources and the thermistor, but fails to provide the details of the temperature sensor, and Funabashi et al.'665 discloses a thermistor thermally coupled to a light source that is capable of measuring a temperature of the light source.

5. Claims 1-3 and 5 are rejected under 35 U.S.C. 103(a) as being unpatentable over Cheung et al.'381 further in view of Dettling'113 (USPN 6,360,113) further in view of Funabashi et al.'665.

Cheung et al.'381 discloses all the elements of the current invention, as discussed in paragraph 2 above, except for the sensor comprising a thermal mass disposed proximate the emitters, wherein the thermal mass stabilizes a bulk temperature of the emitters. Dettling'113 teaches stabilizing the temperatures of emitters in order to reduce the potential for error due to wavelength shift (col. 1, line 65 – col. 2, line 2). It would have been obvious to one of ordinary skill in the art at the time of the invention to modify the sensor of Cheung et al.'381 to be capable of stabilizing the temperature of the light emitting sources, as taught by Dettling'113, since it would reduce error due to wavelength shift. Cheung et al.'381 further in view of Dettling'113 discloses all the elements of the current invention, as discussed above, except for the manner in which the emitter temperatures are stabilized. Funabashi et al.'665 teaches the use of a thermistor and a thermal mass disposed proximate emitters so as to stabilize emitter temperatures

Art Unit: 3768

(page 9, section [0079]). It would have been within the skill of the art to use a thermal mass disposed proximate the emitters, as taught by Funabashi et al.'665, as the temperature stabilization means of Cheung et al.'381 further in view of Dettling'113, since Cheung et al.'381 further in view of Dettling'113 fails to provide details of how the emitter temperatures are stabilized, and Funabashi et al.'665 provides details of a means to stabilize emitter temperatures that is capable of being used with the sensor of Cheung et al.'381 further in view of Dettling'113.

6. Claims 9-12 are rejected under 35 U.S.C. 103(a) as being unpatentable over Noda et al.'588 further in view of Dettling'113 further in view of Funabashi et al.'665 further in view of Cheung et al.'381.

Noda et al.'588 discloses a physiological sensor method, the method comprising: transmitting optical radiation from a plurality of light emitting sources into body tissue and detecting the optical radiation after tissue attenuation (see ABSTRACT). Noda et al.'588 discloses all the elements of the current invention, as discussed above, except for the method comprising determining a plurality of operating wavelengths of the light emitting sources and determining one or more physiological parameters based on the operating wavelengths, wherein the determining step comprises stabilizing a bulk temperature of the light emitting sources and thermally coupling a thermistor proximate to the light emitting sources. Dettling'113 teaches stabilizing the temperatures of emitters in order to reduce the potential for error due to wavelength shift (col. 1, line 65 – col. 2, line 2). It would have been obvious to one of ordinary skill in the art at the time of the invention to modify the method of Noda et al.'588 to include stabilizing the temperature of the light emitting sources, as taught by Dettling'113, since it would reduce error due to wavelength shift. Noda et al.'588 further in view of Dettling'113 discloses all the elements of the current invention, as discussed above, except for the manner in which the emitter temperatures are stabilized. Funabashi et al.'665 teaches the use of a thermistor and a thermal mass disposed proximate emitters so as to stabilize emitter temperatures (page 9, section [0079]). It would have been within the skill of the art to use a thermistor and thermal mass disposed proximate the emitters,

Art Unit: 3768

as taught by Funabashi et al.'665, as the temperature stabilization means of Noda et al.'588 further in view of Dettling'113, since Noda et al.'588 further in view of Dettling'113 fails to provide details of how the emitter temperatures are stabilized, and Funabashi et al.'665 provides details of a means to stabilize emitter temperatures that is capable of being used with the method of Noda et al.'588 further in view of Dettling'113. Noda et al.'588 further in view of Dettling'113 further in view of Funabashi et al.'665 discloses all the elements of the current invention, as discussed above, except for the method comprising determining one or more physiological parameters based on a determined operating wavelength. Cheung et al.'381 teaches determining the operating wavelengths of light emitting sources and compensating a physiological measurement for the effect of temperature on wavelength of the light emitting sources (see ABSTRACT and SUMMARY OF INVENTION). It would have been obvious to one of ordinary skill in the art at the time of the invention to modify the method of Noda et al.'588 further in view of Dettling'113 further in view of Funabashi et al.'665 to include determining the one or more physiological parameters based on determined operating wavelengths, as taught by Cheung et al.'381, since it would allow the affect of temperature variations on the wavelength of light emitted by the light sources to be compensated for when determining the physiological measurement, thereby producing a more accurate physiological measurement.

Allowable Subject Matter

7. The following is a statement of reasons for the indication of allowable subject matter: None of the prior art teaches or suggests, either alone or in combination a physiological sensor wherein either a thermal mass is a plurality of layers of a substrate or wherein a thermal mass is disposed within a substrate proximate light emitting sources and a temperature sensor, in combination with the other claimed elements.

Art Unit: 3768

8. Claims 4 and 6-8 are objected to as being dependent upon a rejected base claim, but would be allowable if rewritten in independent form including all of the limitations of the base claim and any intervening claims.

Conclusion

9. The prior art made of record and not relied upon is considered pertinent to applicant's disclosure. Kaestle'588 (cited by Applicant) and Sakai et al.'877 (cited by Applicant) each disclose an apparatus and method wherein a temperature of light emitting sources within a physiological measurement device is taken and used to determine operating wavelengths of the light emitting sources and compensated physiological measurement values.

Any inquiry concerning this communication or earlier communications from the examiner should be directed to ETSUB D. BERHANU whose telephone number is (571)272-6563. The examiner can normally be reached on Monday - Friday (7:00 - 3:30).

If attempts to reach the examiner by telephone are unsuccessful, the examiner's supervisor, Long Le can be reached on (571)272-0823. The fax phone number for the organization where this application or proceeding is assigned is 571-273-8300.

Art Unit: 3768

Information regarding the status of an application may be obtained from the Patent Application Information Retrieval (PAIR) system. Status information for published applications may be obtained from either Private PAIR or Public PAIR. Status information for unpublished applications is available through Private PAIR only. For more information about the PAIR system, see <http://pair-direct.uspto.gov>. Should you have questions on access to the Private PAIR system, contact the Electronic Business Center (EBC) at 866-217-9197 (toll-free). If you would like assistance from a USPTO Customer Service Representative or access to the automated information system, call 800-786-9199 (IN USA OR CANADA) or 571-272-1000.

/Eric F Winakur/
Primary Examiner, Art Unit 3768

Notice of References Cited	Application/Control No. 11/366,209	Applicant(s)/Patent Under Reexamination AL-ALI ET AL.	
	Examiner ETSUB D. BERHANU	Art Unit 3768	Page 1 of 1

U.S. PATENT DOCUMENTS

*	Document Number Country Code-Number-Kind Code	Date MM-YYYY	Name	Classification
*	A US-6,360,113	03-2002	Dettling, Allen	600/322
*	B US-6,149,588	11-2000	Noda et al.	600/316
*	C US-2002/0154665	10-2002	Funabashi et al.	372/45
	D US-			
	E US-			
	F US-			
	G US-			
	H US-			
	I US-			
	J US-			
	K US-			
	L US-			
	M US-			

FOREIGN PATENT DOCUMENTS

*	Document Number Country Code-Number-Kind Code	Date MM-YYYY	Country	Name	Classification
	N				
	O				
	P				
	Q				
	R				
	S				
	T				

NON-PATENT DOCUMENTS

*	Include as applicable: Author, Title Date, Publisher, Edition or Volume, Pertinent Pages)
U	
V	
W	
X	

*A copy of this reference is not being furnished with this Office action. (See MPEP § 707.05(a).)
Dates in MM-YYYY format are publication dates. Classifications may be US or foreign.

Search Notes 	Application/Control No. 11366209	Applicant(s)/Patent Under Reexamination AL-ALI ET AL.
	Examiner ETSUB D BERHANU	Art Unit 3768

SEARCHED			
Class	Subclass	Date	Examiner
600	310, 331, 333, 336	07/12/2009	EDB

SEARCH NOTES		
Search Notes	Date	Examiner
Searched EAST (USPAT, USPGPUB)	07/12/2009	EDB
Class/subclass search and Keyword search	07/12/2009	EDB
PALM Inventor Name Search	07/12/2009	EDB
See Attached Sheets	07/12/2009	EDB

INTERFERENCE SEARCH			
Class	Subclass	Date	Examiner

--	--



UNITED STATES PATENT AND TRADEMARK OFFICE

UNITED STATES DEPARTMENT OF COMMERCE
 United States Patent and Trademark Office
 Address: COMMISSIONER FOR PATENTS
 P.O. Box 1450
 Alexandria, Virginia 22313-1450
 www.uspto.gov

BIB DATA SHEET

CONFIRMATION NO. 2025

SERIAL NUMBER	FILING or 371(c) DATE	CLASS	GROUP ART UNIT	ATTORNEY DOCKET NO.	
11/366,209	03/01/2006	600	3768	MLR.004A	
<p>RULE</p>					
<p>APPLICANTS Ammar Al-Ali, Tustin, CA; Mohamed Diab, Mission Viejo, CA; Marcelo Lamego, Rancho Santa Margarita, CA; James P. Coffin, Mission Viejo, CA; Yassir Abdul-Hafiz, Irvine, CA;</p>					
<p>** CONTINUING DATA ***** This appln claims benefit of 60/657,596 03/01/2005 and claims benefit of 60/657,281 03/01/2005 and claims benefit of 60/657,268 03/01/2005 and claims benefit of 60/657,759 03/01/2005</p>					
<p>** FOREIGN APPLICATIONS *****</p>					
<p>** IF REQUIRED, FOREIGN FILING LICENSE GRANTED ** 04/06/2006</p>					
Foreign Priority claimed <input type="checkbox"/> Yes <input checked="" type="checkbox"/> No 35 USC 119(a-d) conditions met <input type="checkbox"/> Yes <input checked="" type="checkbox"/> No Verified and Acknowledged <u>/ETSUB D BERHANU/</u> Examiner's Signature	<input type="checkbox"/> Met after Allowance Initials _____	STATE OR COUNTRY CA	SHEETS DRAWINGS 49	TOTAL CLAIMS 15	INDEPENDENT CLAIMS 4
<p>ADDRESS KNOBBE MARTENS OLSON & BEAR LLP 2040 MAIN STREET FOURTEENTH FLOOR IRVINE, CA 92614 UNITED STATES</p>					
<p>TITLE Multiple wavelength sensor substrate</p>					
FILING FEE RECEIVED 1330	FEES: Authority has been given in Paper No. _____ to charge/credit DEPOSIT ACCOUNT No. _____ for following:		<input type="checkbox"/> All Fees <input type="checkbox"/> 1.16 Fees (Filing) <input type="checkbox"/> 1.17 Fees (Processing Ext. of time) <input type="checkbox"/> 1.18 Fees (Issue) <input type="checkbox"/> Other _____ <input type="checkbox"/> Credit		

EAST Search History

Ref #	Hits	Search Query	DBs	Default Operator	Plurals	Time Stamp
L1	141	"20010044700" "20010045532" "20020021269" "20020038078" "20020038081" "20020059047" "20020111748" "20020156353" "20020161291" "20020183819" "20030109775" "20030120160" "20030139657" "20030195402" "20040033618" "20040034898" "20040059209" "20040064259" "20040081621" "20040092805" "20040133087" "20040138538" "20040138540" "20040147823" "20040158134" "20040158135" "20040162472" "20040167382" "20040176670" "20040181134" "20040199063" "20040204639" "20040204868" "20040262046" "20040267103" "20040267140" "20050011488" "20050043902" "20050049469" "20050070773" "20050070775" "20050075546" "20050085735" "20050124871" "20050143634" "20050143943" "20050148834"	US-PGPUB; USPAT; USOCR	OR	OFF	2009/07/12 19:11

"20050184895" |
"20050187447" |
"20050187448" |
"20050187449" |
"20050187450" |
"20050187452" |
"20050187453" |
"20050197549" |
"20050197579" |
"20050197793" |
"20050203357" |
"20050228253" |
"20050250997" |
"20060030764" |
"3998550" | "0033643" |
"0036000" | "4157708" |
"4167331" | "4266554" |
"4446871" | "4586513" |
"4621643" | "4653498" |
"4685464" | "4694833" |
"4700708" | "4714341" |
"4770179" | "4773422" |
"4781195" | "4800885" |
"4832484" | "4846183" |
"4863265" | "4867571" |
"4869254" | "4907876" |
"4911167" | "4934372" |
"4942877" | "4955379" |
"4960126" | "4964010" |
"4967571" | "4975581" |
"4986665" | "4997769" |
"5033472" | "5054495" |
"5058588" | "5078136" |
"5190040" | "5209230" |
"5259381" | "5267562" |
"5267563" | "5278627" |
"5297548" | "5313940" |
"5331549" | "5335659" |
"5348004" | "5351685" |
"5355880" | "5355882" |
"5361758" | "5368224" |
"5385143" | "5387122" |
"5392777" | "5413101" |
"5421329" | "5427093" |
"5429128" | "5435309" |
"5490523" | "5494032" |
"5503148" | "5520177" |
"5533507" | "5551423" |
"5553615" | "5577500" |
"5584299" | "5588427" |
"5590652" | "5595176" |
"5596992" | "5603623" |
"5630413" | "5645059").
PN.

L2	200	"5645060"	"5660567"	US-PGPUB;	OR	OFF	2009/07/12
		"5662106"	"5676139"	USPAT;			19:11
		"5676141"	"5678544"	USOCR			
		"5685301"	"5687719"				
		"5687722"	"5690104"				
		"5692503"	"5697371"				
		"5713355"	"5743263"				
		"5746206"	"5746697"				
		"5752914"	"5755226"				
		"5772587"	"5779630"				
		"5782237"	"5782756"				
		"5790729"	"5792052"				
		"5793485"	"5800348"				
		"5800349"	"5803910"				
		"5807246"	"5807247"				
		"5810723"	"5810724"				
		"5817010"	"5818985"				
		"5823952"	"5827182"				
		"5830137"	"5839439"				
		"5842979"	"5851178"				
		"5851179"	"5853364"				
		"5857462"	"5865736"				
		"5876348"	"5885213"				
		"5891024"	"5910108"				
		"5916154"	"5919133"				
		"5921921"	"5934277"				
		"5954644"	"5978691"				
		"5983122"	"5995856"				
		"5995859"	"5999841"				
		"0555882"	"6006119"				
		"6014576"	"6018673"				
		"6018674"	"6023541"				
		"6064898"	"6068594"				
		"6073037"	"6083172"				
		"6094592"	"6104938"				
		"6112107"	"6122042"				
		"6151518"	"6154667"				
		"6157041"	"6184521"				
		"6226539"	"6230035"				
		"6253097"	"6272363"				
		"6285895"	"6298252"				
		"6304675"	"6304767"				
		"6330468"	"6341257"				
		"6351658"	"6356774"				
		"6363269"	"6374129"				
		"6377828"	"6393310"				
		"6397092"	"6397093"				
		"6408198"	"6411833"				
		"6415166"	"6415233"				
		"6415236"	"6434408"				
		"6441388"	"6453184"				
		"6463310"	"6480729"				
		"6490466"	"6497659"				

		"6501974" "6504943" "6505060" "6505061" "6505133" "6510329" "6519486" "6522398" "6526301" "6528809" "6537225" "6546267" "6553241" "6564077" "6571113" "6582964" "6584413" "6591123" "6594511" "6600940" "6606509" "6606510" "6611698" "6614521" "6615064" "6615151" "6618602" "6622095" "6628975" "6631281" "6654623" "6657717" "6658277" "6662033" "6665551" "6668183" "6671526" "6675031" "6675106" "6681126" "6687620" "6694157" "6697655" "6701170" "6708049" "6711503" "6714803" "6714805" "6719705" "6720734" "6721584" "6725074" "6726634" "6741875" "6741876" "6743172" "6745061" "6748253" "6748254" "6754515" "6754516" "6760609" "6773397" "6778923" "6780158" "6788849" "6801797" "6801799" "6810277" "6819950" "6825619" "6829496" "6836679" "6839579" "6839580" "6839582" "6842702" "6845256" "6847835" "6869402" "6882874" "6912049" "6917422" "6919566" "6921367" "6922645" "6928311" "6931269" "6944487" "6975891" "6987994" "7001337" "7006856").PN.				
L3	2	kaestle.in. and resistor	US-PGPUB; USPAT; USOCR	OR	OFF	2009/07/12 19:12
L4	18	sakai.in. and wavelength with memory	US-PGPUB; USPAT; USOCR	OR	OFF	2009/07/12 19:12

L5	1	"20060211922"	US-PGPUB; USPAT; USOCR	OR	OFF	2009/07/12 19:16
L6	0	("2006/0211922").URPN.	USPAT	OR	OFF	2009/07/12 19:23
L7	21	1 and temperature	USPAT	OR	OFF	2009/07/12 19:24
L8	68	2 and temperature	USPAT	OR	OFF	2009/07/12 19:25
L9	40	1 and temperature	US-PGPUB; USPAT; USOCR	OR	OFF	2009/07/12 19:25
L10	68	2 and temperature	US-PGPUB; USPAT; USOCR	OR	OFF	2009/07/12 19:25
L11	1	"20060211922" and thermal adj mass	US-PGPUB; USPAT; USOCR	OR	OFF	2009/07/12 19:37
L12	1197	600/310.ccls.	US-PGPUB; USPAT; USOCR	OR	OFF	2009/07/12 20:41
L13	86	600/331.ccls.	US-PGPUB; USPAT; USOCR	OR	OFF	2009/07/12 20:41
L14	34	600/333.ccls.	US-PGPUB; USPAT; USOCR	OR	OFF	2009/07/12 20:41
L15	226	600/336.ccls.	US-PGPUB; USPAT; USOCR	OR	OFF	2009/07/12 20:42
L16	6213	stabiliz\$5 with temperature with (led diode source laser radiation emitter emitting)	US-PGPUB; USPAT; USOCR	OR	ON	2009/07/12 20:42
L17	294	stabiliz\$5 with temperature with (led diode source laser radiation emitter emitting) same thermistor	US-PGPUB; USPAT; USOCR	OR	ON	2009/07/12 20:43
L18	265	17 and @py<"2006"	US-PGPUB; USPAT; USOCR	OR	ON	2009/07/12 20:43
L19	6	18 and "600"/\$.ccls.	US-PGPUB; USPAT; USOCR	OR	ON	2009/07/12 20:57

L20	28	600/309-344.ccls. and wavelength with stabiliz\$5	US-PGPUB; USPAT; USOCR	OR	OFF	2009/07/12 21:09
L21	101	600/322.ccls. and laser with diodes	US-PGPUB; USPAT; USOCR	OR	OFF	2009/07/12 21:27
L22	77	21 and @py<"2006"	US-PGPUB; USPAT; USOCR	OR	OFF	2009/07/12 21:27
L23	74	21 and @py<"2005"	US-PGPUB; USPAT; USOCR	OR	OFF	2009/07/12 21:27
L24	105	600/323.ccls. and laser with diodes	US-PGPUB; USPAT; USOCR	OR	OFF	2009/07/12 21:29
L25	57	24 and @py<"2004"	US-PGPUB; USPAT; USOCR	OR	OFF	2009/07/12 21:29
L26	115	600/322-344.ccls. and semiconductor with laser	US-PGPUB; USPAT; USOCR	OR	ON	2009/07/12 21:38
L27	51	26 and @py<"2004"	US-PGPUB; USPAT; USOCR	OR	ON	2009/07/12 21:39

7/ 12/ 2009 10:07:40 PM

C:\ Documents and Settings\ eberhanu\ My Documents\ EAST\ Workspaces\ 11366209.wsp

Receipt date: 02/20/2007

PTO/SB/08 Equivalent

INFORMATION DISCLOSURE STATEMENT BY APPLICANT	Application No.	11/366,209
	Filing Date	March 1, 2006
	First Named Inventor	Ammar Al-Ali
	Art Unit	3768
<i>(Multiple sheets used when necessary)</i>	Examiner	Winakur, Eric F.
SHEET 1 OF 1	Attorney Docket No.	MLR.004A

U.S. PATENT DOCUMENTS					
Examiner Initials	Cite No.	Document Number Number - Kind Code (if known) Example: 1,234,567 B1	Publication Date MM-DD-YYYY	Name of Patentee or Applicant	Pages, Columns, Lines Where Relevant Passages or Relevant Figures Appear
	1	US 2002/156353 A1	10-24-2002	Eric Russell Larson	
	2	US 2001/045532 A1	11-29-2001	Charles E. Schulz, et al.	
	3	US 6,285,895 B1	09-04-2001	Kimmo Juhani Ristolainen, et al.	

FOREIGN PATENT DOCUMENTS						
Examiner Initials	Cite No.	Foreign Patent Document Country Code-Number-Kind Code Example: JP 1234567 A1	Publication Date MM-DD-YYYY	Name of Patentee or Applicant	Pages, Columns, Lines Where Relevant Passages or Relevant Figures Appear	T ¹

NON PATENT LITERATURE DOCUMENTS			
Examiner Initials	Cite No.	Include name of the author (in CAPITAL LETTERS), title of the article (when appropriate), title of the item (book, magazine, journal, serial, symposium, catalog, etc.), date, page(s), volume-issue number(s), publisher, city and/or country where published.	T ¹
	4	International Search Report for PCT/US2006/007516, mailed on 01-11-2007, in 4 pages.	
	5	SCHMITT, JOSEPH M.; ZHOU, GUAN-XIONG; MILLER, JUSTIN, <u>Measurement of Blood Hematocrit by Dual-wavelength Near-IR Photoplethysmography</u> , published May 1992, Proc. SPIE Vol.1641, p.150-161, Physiological Monitoring and Early Detection Diagnostic Methods, Thomas S. Mang; Ed. (SPIE homepage), in 12 pages.	

3427772:cy
021407

Examiner Signature	/Etsub Berhanu/ (07/12/2009)	Date Considered
<p>*Examiner: Initial if reference considered, whether or not citation is in conformance with MPEP 609. Draw line through citation if not in conformance and not considered. Include copy of this form with next communication to applicant.</p>		

T¹ - Place a check mark in this area when an English language Translation is attached.

ALL REFERENCES CONSIDERED EXCEPT WHERE LINED THROUGH. /EB/

**INFORMATION DISCLOSURE
STATEMENT BY APPLICANT**

(Multiple sheets used when necessary)

SHEET 1 OF 13

Application No.	11/366,209
Filing Date	March 1, 2006
First Named Inventor	Ammar Al-Ali et al.
Art Unit	3735
Examiner	
Attorney Docket No.	MLR.004A

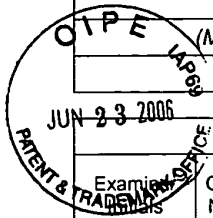

U.S. PATENT DOCUMENTS

Examination Cite No.	Document Number Number - Kind Code (if known) Example: 1,234,567 B1	Publication Date MM-DD-YYYY	Name of Patentee or Applicant	Pages, Columns, Lines Where Relevant Passages or Relevant Figures Appear
1	7,006,856	02-28-2006	Baker, Jr. et al.	
2	7,001,337	02-21-2006	Dekker	
3	6,987,994	01-17-2006	Mortz	
4	6,975,891	12-13-2005	Pawluczyk	
5	6,944,487	09-13-2005	Maynard, et al.	
6	6,931,269	08-16-2005	Terry	
7	6,928,311	08-09-2005	Pawluczyk et al.	
8	6,922,645	07-26-2005	Haaland et al.	
9	6,921,367	07-26-2005	Mills	
10	6,919,566	07-19-2005	Cadell	
11	6,917,422	07-12-2005	Samsoondar et al.	
12	6,912,049	06-28-2005	Pawluczyk et al.	
13	6,882,874	04-19-2005	Huiku	
14	6,869,402	03-22-2005	Arnold	
15	6,847,835	01-25-2005	Yamanishi	
16	6,845,256	01-18-2005	Chin et al.	
17	6,842,702	01-11-2005	Haaland et al.	
18	6,839,582	01-04-2005	Heckel	
19	6,839,580	01-04-2005	Zonios, et al.	
20	6,839,579	01-04-2005	Chin	
21	6,836,679	12-28-2004	Baker JR. et al.	
22	6,829,496	12-07-2004	Nagai, et al.	
23	6,825,619	11-30-2004	Norris	
24	6,819,950	11-16-2004	Mills	
25	6,810,277	10-26-2004	Edgar, Jr, et al.	
26	6,801,799	10-05-2004	Mendelson	

Examiner Signature	Date Considered
*Examiner: Initial if reference considered, whether or not citation is in conformance with MPEP 609. Draw line through citation if not in conformance and not considered. Include copy of this form with next communication to applicant.	

T¹ - Place a check mark in this area when an English language Translation is attached.

ALL REFERENCES CONSIDERED EXCEPT WHERE LINED THROUGH. /EB/

INFORMATION DISCLOSURE STATEMENT BY APPLICANT	Application No.	11/366,209
	Filing Date	March 1, 2006
	First Named Inventor	Ammar Al-Ali et al.
	Art Unit	3735
(Multiple sheets used when necessary)	Examiner	
SHEET 2 OF 13	Attorney Docket No.	MLR.004A

U.S. PATENT DOCUMENTS					
Examiner Initials	Cite No.	Document Number Number - Kind Code (if known) Example: 1,234,567 B1	Publication Date MM-DD-YYYY	Name of Patentee or Applicant	Pages, Columns, Lines Where Relevant Passages or Relevant Figures Appear
	27	6,801,797	10-05-2004	Mannheimer et al.	
	28	6,788,849	09-07-2004	Pawluczyk	
	29	6,780,158	08-24-2004	Yarita	
	30	6,780,158	08-24-2004	Yarita	
	31	6,778,923	08-17-2004	Norris et al.	
	32	6,773,397	08-10-2004	Kelly	
	33	6,760,609	07-06-2004	Jacques	
	34	6,754,516	06-22-2004	Mannheimer	
	35	6,754,515	06-22-2004	Pologe	
	36	6,748,254	06-08-2004	O'Neil et al.	
	37	6,748,253	06-08-2004	Norris et al.	
	38	6,745,061	06-01-2004	Hicks et al.	
	39	6,741,876	05-25-2004	Scecina et al.	
	40	6,741,875	05-25-2004	Pawluczyk et al.	
	41	6,726,634	04-27-2004	Freeman	
	42	6,725,074	04-20-2004	Kastle	
	43	6,721,584	04-13-2004	Baker JR. et al.	
	44	6,720,734	04-13-2004	Norris	
	45	6,719,705	04-13-2004	Mills	
	46	6,714,805	03-30-2004	Jeon, et al.	
	47	6,714,803	03-30-2004	Mortz	
	48	6,711,503	03-23-2004	Haaland	
	49	6,708,049	03-16-2004	Berson et al.	
	50	6,701,170	03-02-2004	Stetson	
	51	6,697,655	02-24-2004	Sueppel, et al.	
	52	6,694,157	02-17-2004	Stone et al.	

Examiner Signature	Date Considered
*Examiner: Initial if reference considered, whether or not citation is in conformance with MPEP 609. Draw line through citation if not in conformance and not considered. Include copy of this form with next communication to applicant.	

T¹ - Place a check mark in this area when an English language Translation is attached.

ALL REFERENCES CONSIDERED EXCEPT WHERE LINED THROUGH. /EB/

INFORMATION DISCLOSURE STATEMENT BY APPLICANT	Application No.	11/366,209
	Filing Date	March 1, 2006
	First Named Inventor	Ammar Al-Ali et al.
	Art Unit	3735
(Multiple sheets used when necessary)	Examiner	
SHEET 3 OF 13	Attorney Docket No.	MLR.004A

U.S. PATENT DOCUMENTS					
Examiner Initials	Cite No.	Document Number Number - Kind Code (if known) Example: 1,234,567 B1	Publication Date MM-DD-YYYY	Name of Patentee or Applicant	Pages, Columns, Lines Where Relevant Passages or Relevant Figures Appear
	53	6,687,620	02-03-2004	Haaland et al.	
	54	6,681,126	01-20-2004	Solenberger	
	55	6,675,106	01-06-2004	Keenan et al.	
	56	6,675,031	01-06-2004	Porges, et al.	
	57	6,671,526	12-30-2003	Aoyagi et al.	
	58	6,668,183	12-23-2003	Hicks et al.	
	59	6,665,551	12-16-2003	Suzuki	
	60	6,662,033	12-09-2003	Casciani et al.	
	61	6,658,277	12-02-2003	Wasserman	
	62	6,657,717	12-02-2003	Cadell et al.	
	63	6,654,623	11-25-2003	Kastle	
	64	6,631,281	10-07-2003	Kastle	
	65	6,628,975	09-30-2003	Fein et al.	
	66	6,622,095	09-16-2003	Kobayashi et al.	
	67	6,618,602	09-09-2003	Levin	
	68	6,615,151	09-02-2003	Seccina et al.	
	69	6,615,064	09-02-2003	Aldrich	
	70	6,614,521	09-02-2003	Samsoondar et al.	
	71	6,606,510	08-12-2003	Swedlow, et al.	
	72	6,606,509	08-12-2003	Schmitt	
	73	6,600,940	07-29-2003	Fein, et al.	
	74	6,594,511	07-15-2003	Stone et al.	
	75	6,591,123	07-08-2003	Fein et al.	
	76	6,584,413	06-24-2003	Keenan et al.	
	77	6,582,964	06-24-2003	Samsoondar et al.	
	78	6,571,113	05-27-2003	Fein, et al.	
	79	6,564,077	05-13-2003	Mortara	

Examiner Signature	Date Considered
*Examiner: Initial if reference considered, whether or not citation is in conformance with MPEP 609. Draw line through citation if not in conformance and not considered. Include copy of this form with next communication to applicant.	

T¹ - Place a check mark in this area when an English language Translation is attached.

ALL REFERENCES CONSIDERED EXCEPT WHERE LINED THROUGH. /EB/

INFORMATION DISCLOSURE STATEMENT BY APPLICANT	Application No.	11/366,209
	Filing Date	March 1, 2006
	First Named Inventor	Ammar Al-Ali et al.
	Art Unit	3735
<i>(Multiple sheets used when necessary)</i>		Examiner
SHEET 4 OF 13		Attorney Docket No. MLR.004A

U.S. PATENT DOCUMENTS					
Examiner Initials	Cite No.	Document Number Number - Kind Code (if known) Example: 1,234,567 B1	Publication Date MM-DD-YYYY	Name of Patentee or Applicant	Pages, Columns, Lines Where Relevant Passages or Relevant Figures Appear
	80	6,553,241	04-22-2003	Mannheimer, et al.	
	81	6,546,267	04-08-2003	Sugiura	
	82	6,537,225	03-25-2003	Mills	
	83	6,528,809	03-04-2003	Thomas et al.	
	84	6,526,301	02-25-2003	Larsen et al.	
	85	6,522,398	02-18-2003	Cadell et al.	
	86	6,519,486	02-11-2003	Edgar, Jr., et al.	
	87	6,510,329	01-21-2003	Heckel	
	88	6,505,133	01-07-2003	Hanna	
	89	6,505,061	01-07-2003	Larson	
	90	6,505,060	01-07-2003	Norris	
	91	6,504,943	01-07-2003	Sweatt et al.	
	92	6,501,974	12-31-2002	Huiku	
	93	6,497,659	12-24-2002	Rafert	
	94	6,490,466	12-03-2002	Fein et al.	
	95	6,480,729	11-12-2002	Stone	
	96	6,463,310	10-08-2002	Swedlow et al.	
	97	6,453,184	09-17-2002	Hyogo et al.	
	98	6,441,388	08-27-2002	Thomas et al.	
	99	6,434,408	08-13-2002	Heckel	
	100	6,415,236	07-02-2002	Kobayashi et al.	
	101	6,415,233	07-02-2002	Haaland	
	102	6,415,166	07-02-2002	Van Hoy et al.	
	103	6,411,833	06-25-2002	Baker, Jr. et al.	
	104	6,408,198	06-18-2002	Hanna et al.	
	105	6,397,093	05-28-2002	Aldrich	

Examiner Signature	Date Considered
*Examiner: Initial if reference considered, whether or not citation is in conformance with MPEP 609. Draw line through citation if not in conformance and not considered. Include copy of this form with next communication to applicant.	

T¹ - Place a check mark in this area when an English language Translation is attached.

ALL REFERENCES CONSIDERED EXCEPT WHERE LINED THROUGH. /EB/

INFORMATION DISCLOSURE STATEMENT BY APPLICANT	Application No.	11/366,209
	Filing Date	March 1, 2006
	First Named Inventor	Ammar Al-Ali et al.
	Art Unit	3735
(Multiple sheets used when necessary)	Examiner	
SHEET 5 OF 13	Attorney Docket No.	MLR.004A

U.S. PATENT DOCUMENTS					
Examiner Initials	Cite No.	Document Number Number - Kind Code (if known) Example: 1,234,567 B1	Publication Date MM-DD-YYYY	Name of Patentee or Applicant	Pages, Columns, Lines Where Relevant Passages or Relevant Figures Appear
	106	6,397,092	05-28-2002	Norris et al.	
	107	6,393,310	05-21-2002	Kuenstner	
	108	6,377,828	04-23-2002	Chaiken, et al.	
	109	6,374,129	04-16-2002	Chin, et al.	
	110	6,363,269	03-26-2002	Hanna et al.	
	111	6,356,774	01-12-2002	Bernstein et al.	
	112	6,351,658	02-26-2002	Middleman et al.	
	113	6,341,257	01-22-2002	Haaland	
	114	6,330,468	12-11-2001	Scharf	
	115	6,304,767	10-16-2001	Soller et al.	
	116	6,304,675	10-16-2001	Osbourn et al.	
	117	6,298,252	10-02-2001	Kovach et al.	
	118	6,272,363	08-07-2001	Casciani et al.	
	119	6,230,035	05-08-2001	Aoyagi et al.	
	120	6,226,539	05-01-2001	Potratz	
	121	6,157,041	12-05-2000	Thomas et al.	
	122	6,154,667	11-28-2000	Miura et al.	
	123	6,151,518	11-21-2000	Hayashi	
	124	6,112,107	08-29-2000	Hannula	
	125	6,104,938	08-15-2000	Huiku	
	126	6,094,592	07-25-2000	Yorkey et al.	
	127	6,083,172	07-04-2000	Baker JR. et al.	
	128	6,073,037	06-06-2000	Alam et al.	
	129	6,068,594	05-30-2000	Schloemer et al.	
	130	6,064,898	05-16-2000	Aldrich	
	131	6,023,541	02-08-2000	Merchant et al.	

Examiner Signature	Date Considered
*Examiner: Initial if reference considered, whether or not citation is in conformance with MPEP 609. Draw line through citation if not in conformance and not considered. Include copy of this form with next communication to applicant.	

T¹ - Place a check mark in this area when an English language Translation is attached.

ALL REFERENCES CONSIDERED EXCEPT WHERE LINED THROUGH. /EB/

INFORMATION DISCLOSURE STATEMENT BY APPLICANT	Application No.	11/366,209
	Filing Date	March 1, 2006
	First Named Inventor	Ammar Al-Ali et al.
	Art Unit	3735
(Multiple sheets used when necessary)	Examiner	
SHEET 6 OF 13	Attorney Docket No.	MLR.004A

U.S. PATENT DOCUMENTS					
Examiner Initials	Cite No.	Document Number Number - Kind Code (if known) Example: 1,234,567 B1	Publication Date MM-DD-YYYY	Name of Patentee or Applicant	Pages, Columns, Lines Where Relevant Passages or Relevant Figures Appear
	132	6,018,674	01-25-2000	Aronow	
	133	6,018,673	01-25-2000	Chin et al.	
	134	6,014,576	01-11-2000	Raley	
	135	6,006,119	12-21-1999	Soller et al.	
	136	5,999,841	12-07-1999	Aoyagi et al.	
	137	5,995,859	11-30-1999	Takahashi	
	138	5,995,856	11-30-1999	Mannheimer et al.	
	139	5,983,122	11-09-1999	Jarman et al.	
	140	5,978,691	11-02-1999	Mills	
	141	5,954,644	09-21-1999	Dettling	
	142	5,934,277	08-10-1999	Mortz	
	143	5,921,921	07-13-1999	Potratz et al.	
	144	5,919,133	07-06-1999	Taylor	
	145	5,916,154	06-29-1999	Hobbs et al.	
	146	5,910,108	06-08-1999	Solenberger	
	147	5,891,024	04-06-1999	Jarman et al.	
	148	5,885,213	03-23-1999	Richardson et al.	
	149	5,876,348	03-02-1999	Sugo	
	150	5,865,736	02-02-1999	Baker JR. et al.	
	151	5,857,462	01-12-1999	Thomas et al.	
	152	5,853,364	12-29-1998	Baker, Jr., et al.	
	153	5,851,179	12-22-1998	Ritson et al.	
	154	5,851,178	12-22-1998	Aronow	
	155	5,842,979	12-01-1998	Jarman	
	156	5,839,439	11-24-1998	Nierlich et al.	
	157	5,830,137	11-03-1998	Sharf	

Examiner Signature	Date Considered
*Examiner: Initial if reference considered, whether or not citation is in conformance with MPEP 609. Draw line through citation if not in conformance and not considered. Include copy of this form with next communication to applicant.	

T¹ - Place a check mark in this area when an English language Translation is attached.

ALL REFERENCES CONSIDERED EXCEPT WHERE LINED THROUGH. /EB/

INFORMATION DISCLOSURE STATEMENT BY APPLICANT	Application No.	11/366,209
	Filing Date	March 1, 2006
	First Named Inventor	Ammar Al-Ali et al.
	Art Unit	3735
<i>(Multiple sheets used when necessary)</i>		Examiner
SHEET 7 OF 13		Attorney Docket No. MLR.004A

U.S. PATENT DOCUMENTS					
Examiner Initials	Cite No.	Document Number Number - Kind Code (if known) Example: 1,234,567 B1	Publication Date MM-DD-YYYY	Name of Patentee or Applicant	Pages, Columns, Lines Where Relevant Passages or Relevant Figures Appear
	158	5,827,182	10-27-1998	Raley	
	159	5,823,952	10-20-1998	Levinson et al.	
	160	5,818,985	10-06-1998	Merchant et al.	
	161	5,817,010	10-06-1998	Hibl	
	162	5,810,724	09-22-1998	Gronvall	
	163	5,810,723	09-22-1998	Aldrich	
	164	5,807,247	09-15-1998	Merchant et al.	
	165	5,807,246	09-15-1998	Sakaguchi et al.	
	166	5,803,910	09-08-1998	Potratz	
	167	5,800,349	09-01-1998	Isaacson et al.	
	168	5,793,485	08-11-1998	Gourley	
	169	5,792,052	08-11-1998	Isaacson et al.	
	170	5,790,729	08-04-1998	Pologe et al.	
	171	5,782,756	07-21-1998	Mannheimer	
	172	5,782,237	07-21-1998	Casciani et al.	
	173	5,779,630	07-14-1998	Fein et al.	
	174	5,772,587	06-30-1998	Gratton, et. al	
	175	5,755,226	05-26-1998	Carim et al.	
	176	5,752,914	05-19-1998	Delonzor et al.	
	177	5,746,697	05-05-1998	Swedlow et al.	
	178	5,746,206	05-05-1998	Mannheimer	
	179	5,743,263	04-28-1998	Baker, Jr.	
	180	5,713,355	02-03-1998	Richardson et al.	
	181	5,697,371	12-16-1997	Aoyagi	
	182	5,692,503	12-02-1997	Kuenstner	
	183	5,690,104	11-25-1997	Kanemoto, et al.	
	184	5,687,722	11-18-1997	Tien et al.	

Examiner Signature	Date Considered
*Examiner: Initial if reference considered, whether or not citation is in conformance with MPEP 609. Draw line through citation if not in conformance and not considered. Include copy of this form with next communication to applicant.	

T¹ - Place a check mark in this area when an English language Translation is attached.

ALL REFERENCES CONSIDERED EXCEPT WHERE LINED THROUGH. /EB/

INFORMATION DISCLOSURE STATEMENT BY APPLICANT	Application No.	11/366,209
	Filing Date	March 1, 2006
	First Named Inventor	Ammar Al-Ali et al.
	Art Unit	3735
<i>(Multiple sheets used when necessary)</i>		Examiner
SHEET 8 OF 13		Attorney Docket No. MLR.004A

U.S. PATENT DOCUMENTS					
Examiner Initials	Cite No.	Document Number Number - Kind Code (if known) Example: 1,234,567 B1	Publication Date MM-DD-YYYY	Name of Patentee or Applicant	Pages, Columns, Lines Where Relevant Passages or Relevant Figures Appear
	185	5,687,719	11-18-1997	Sato, et al.	
	186	5,685,301	11-11-1997	Klomhaus	
	187	5,678,544	10-21-1997	Delonzor et al.	
	188	5,676,141	10-14-1997	Hollub	
	189	5,676,139	10-14-1997	Goldberger et al.	
	190	5,662,106	09-02-1997	Swedlow et al.	
	191	5,660,567	08-26-1997	Nierlich et al.	
	192	5,645,060	07-08-1997	Yorkey	
	193	5,630,413	05-20-1997	Thomas et al.	
	194	5,603,623	02-18-1997	Nishikawa et al.	
	195	5,596,992	01-28-1997	Haaland et al.	
	196	5,595,176	01-21-1997	Yamaura	
	197	5,590,652	01-07-1997	Inai	
	198	5,588,427	12-31-1996	Tien	
	199	5,584,299	12-17-1996	Sakai et al.	
	200	5,577,500	11-26-1996	Potratz	
	201	5,555,882	09-17-1996	Richardson et al.	
	202	5,553,615	09-10-1996	Carim, et al.	
	203	5,551,423	09-03-1996	Sugiura	
	204	5,533,507	07-09-1996	Potratz	
	205	5,520,177	05-28-1996	Ogawa	
	206	5,503,148	04-02-1996	Pologe et al.	
	207	5,494,032	02-27-1996	Robinson et al.	
	208	5,490,523	02-13-1996	Isacson et al.	
	209	5,435,309	07-25-1995	Thomas et al.	
	210	5,429,128	07-04-1995	Cadell et al.	
	211	5,427,093	06-27-1995	Ogawa et al.	

Examiner Signature	Date Considered
<p>*Examiner: Initial if reference considered, whether or not citation is in conformance with MPEP 609. Draw line through citation if not in conformance and not considered. Include copy of this form with next communication to applicant.</p>	

T¹ - Place a check mark in this area when an English language Translation is attached.

ALL REFERENCES CONSIDERED EXCEPT WHERE LINED THROUGH. /EB/

INFORMATION DISCLOSURE STATEMENT BY APPLICANT	Application No.	11/366,209
	Filing Date	March 1, 2006
	First Named Inventor	Ammar Al-Ali et al.
	Art Unit	3735
(Multiple sheets used when necessary)	Examiner	
SHEET 9 OF 13	Attorney Docket No.	MLR.004A

U.S. PATENT DOCUMENTS					
Examiner Initials	Cite No.	Document Number Number - Kind Code (if known) Example: 1,234,567 B1	Publication Date MM-DD-YYYY	Name of Patentee or Applicant	Pages, Columns, Lines Where Relevant Passages or Relevant Figures Appear
	212	5,421,329	06-06-1995	Casciani et al.	
	213	5,413,101	05-09-1995	Sugiura	
	214	5,392,777	02-28-1995	Swedlow et al.	
	215	5,387,122	02-07-1995	Goldberger et al.	
	216	5,385,143	01-31-1995	Aoyagi	
	217	5,368,224	11-29-1994	Richardson et al.	
	218	5,361,758	11-08-1994	Hall et al.	
	219	5,355,882	10-18-1994	Ukawa et al.	
	220	5,355,880	10-18-1994	Thomas et al.	
	221	5,351,685	10-04-1994	Potratz	
	222	5,348,004	09-20-1994	Hollub	
	223	5,335,659	08-09-1994	Pologe et al.	
	224	5,313,940	5-24-1994	Fuse et al.	
	225	5,297,548	03-29-1994	Pologe	
	226	5,278,627	01-11-1994	Aoyagi	
	227	5,267,563	12-07-1993	Swedlow et al.	
	228	5,267,562	12-07-1993	Ukawa et al.	
	229	5,209,230	05-11-1993	Swedlow et al.	
	230	5,190,040	03-02-1993	Aoyagi	
	231	5,078,136	01-07-1992	Stone et al.	
	232	5,054,495	10-08-1991	Uemura, et al.	
	233	5,033,472	07-23-1991	Sato, et al.	
	234	4,997,769	03-05-1991	Lundsgaard	
	235	4,975,581	12-04-1990	Robinson et al.	
	236	4,967,571	11-06-1990	Sporri	
	237	4,964,010	10-16-1990	Miyasaka et al.	

Examiner Signature	Date Considered
*Examiner: Initial if reference considered, whether or not citation is in conformance with MPEP 609. Draw line through citation if not in conformance and not considered. Include copy of this form with next communication to applicant.	

T¹ - Place a check mark in this area when an English language Translation is attached.

ALL REFERENCES CONSIDERED EXCEPT WHERE LINED THROUGH. /EB/

INFORMATION DISCLOSURE STATEMENT BY APPLICANT	Application No.	11/366,209
	Filing Date	March 1, 2006
	First Named Inventor	Ammar Al-Ali et al.
	Art Unit	3735
<i>(Multiple sheets used when necessary)</i>	Examiner	
SHEET 10 OF 13	Attorney Docket No.	MLR.004A

U.S. PATENT DOCUMENTS					
Examiner Initials	Cite No.	Document Number Number - Kind Code (if known) Example: 1,234,567 B1	Publication Date MM-DD-YYYY	Name of Patentee or Applicant	Pages, Columns, Lines Where Relevant Passages or Relevant Figures Appear
	238	4,960,126	10-02-1990	Conlon et al.	
	239	4,955,379	09-11-1990	Hall	
	240	4,942,877	07-24-1990	Sakai et al.	
	241	4,934,372	06-19-1990	Corenman et al.	
	242	4,911,167	03-27-1990	Corenman et al.	
	243	4,869,254	09-26-1989	Stone et al.	
	244	4,867,571	09-19-1989	Frick et al.	
	245	4,863,265	09-05-1989	Flower, et al.	
	246	4,846,183	07-11-1989	Martin	
	247	4,832,484	05-23-1989	Aoyagi, et al.	
	248	4,800,885	01-31-1989	Johnson	
	249	4,781,195	11-01-1988	Martin	
	250	4,773,422	09-27-1988	Isaacson et al.	
	251	4,770,179	09-13-1988	New et al.	
	252	4,714,341	12-22-1987	Hamaguri et al.	
	253	4,700,708	10-20-1987	New et al.	
	254	4,694,833	09-22-1987	Hamaguri	
	255	4,685,464	08-11-1987	Goldberger	
	256	4,653,498	03-31-1987	New et al.	
	257	4,621,643	11-11-1986	New et al.	
	258	4,586,513	05-06-1986	Hamaguri	
	259	4,446,871	05-08-1984	Imura	
	260	4,266,554	05-12-1981	Hamaguri	
	261	4,167,331	09-11-1979	Nielsen	
	262	4,157,708	06-12-1979	Imura	
	263	3,998,550	12-21-1976	Konishi, et al.	

Examiner Signature	Date Considered
*Examiner: Initial if reference considered, whether or not citation is in conformance with MPEP 609. Draw line through citation if not in conformance and not considered. Include copy of this form with next communication to applicant.	

T¹ - Place a check mark in this area when an English language Translation is attached.

ALL REFERENCES CONSIDERED EXCEPT WHERE LINED THROUGH. /EB/

INFORMATION DISCLOSURE STATEMENT BY APPLICANT	Application No.	11/366,209
	Filing Date	March 1, 2006
	First Named Inventor	Ammar Al-Ali et al.
	Art Unit	3735
(Multiple sheets used when necessary)	Examiner	
SHEET 11 OF 13	Attorney Docket No.	MLR.004A

U.S. PATENT DOCUMENTS					
Examiner Initials	Cite No.	Document Number Number - Kind Code (if known) Example: 1,234,567 B1	Publication Date MM-DD-YYYY	Name of Patentee or Applicant	Pages, Columns, Lines Where Relevant Passages or Relevant Figures Appear
	264	RE35,122	12-19-1995	Corenman et al.	
	265	2004/0006261	01-08-2004	Swedlow et al.	
	266	2006/0030764	02-09-2006	Porges et al.	
	267	2004/0033618	02-19-2004	Haass, et al.	
	268	2002/0038078	03-28-2002	Ito	
	269	2005/0043902	02-24-2005	Haaland et al.	
	270	2005/0049469	03-03-2005	Aoyagi et al.	
	271	2002/0059047	05-16-2002	Haaland	
	272	2004/0064259	04-01-2004	Haaland et al.	
	273	2005/0070773	03-31-2005	Chin et al.	
	274	2005/0070775	03-31-2005	Chin et al.	
	275	2005/0075546	04-07-2005	Samsoondar et al.	
	276	2005/0085735	04/21-2005	Baker JR. et al.	
	277	2004/0092805	05-13-2004	Yarita	
	278	2003/0109775	06-12-2003	O'Neil, et al.	
	279	2002/0111748	08-15-2002	Kobayashi et al.	
	280	2003/0120160	06-26-2003	Yarita	
	281	2005/0124871	06/09-2005	Baker JR. et al.	
	282	2004/0138538	07-15-2004	Stetson	
	283	2004/0138540	07-15-2004	Baker JR. et al.	
	284	2003/0139657	07-24-2003	Solenberger	
	285	2005/143634	06-30-2005	Baker JR. et al.	
	286	2005/0143943	06-30-2005	Brown	
	287	2005/0148834	07-07-2005	Hull, et al.	
	288	2004/0158135	08-12-2004	Baker JR. et al.	
	289	2004/0162472	08-19-2004	Berson et al.	
	290	2004/0167382	08-26-2004	Gardner, et al.	

Examiner Signature	Date Considered
*Examiner: Initial if reference considered, whether or not citation is in conformance with MPEP 609. Draw line through citation if not in conformance and not considered. Include copy of this form with next communication to applicant.	

T¹ - Place a check mark in this area when an English language Translation is attached.

ALL REFERENCES CONSIDERED EXCEPT WHERE LINED THROUGH. /EB/

INFORMATION DISCLOSURE STATEMENT BY APPLICANT	Application No.	11/366,209
	Filing Date	March 1, 2006
	First Named Inventor	Ammar Al-Ali et al.
	Art Unit	3735
<i>(Multiple sheets used when necessary)</i>		Examiner
SHEET 12 OF 13		Attorney Docket No. MLR.004A

U.S. PATENT DOCUMENTS					
Examiner Initials	Cite No.	Document Number Number - Kind Code (if known) Example: 1,234,567 B1	Publication Date MM-DD-YYYY	Name of Patentee or Applicant	Pages, Columns, Lines Where Relevant Passages or Relevant Figures Appear
	291	2004/0167382	08-26-2004	Gardner et al.	
	292	2004/0176670	09-09-2004	Takamura et al.	
	293	2004/0181134	09-16-2004	Baker JR. et al.	
	294	2005/0184895	08-25-2005	Petersen et al.	
	295	2005/0187447	08-25-2005	Chew et al.	
	296	2005/0187448	08-25-2005	Petersen et al.	
	297	2005/0187449	08-25-2005	Chew et al.	
	298	2005/0187450	08-25-2005	Chew et al.	
	299	2005/0187452	08-25-2005	Petersen et al.	
	300	2005/0187453	08-25-2005	Petersen et al.	
	301	2003/0195402	10-16-2003	Fein et al.	
	302	2005/0197549	09-08-2005	Baker JR.	
	303	2005/0197579	09-08-2005	Baker JR.	
	304	2005/0197793	09-08-2005	Baker JR.	
	305	2004/0199063	10-07-2004	O'Neil et al.	
	306	2005/0203357	09-15-2005	Debreczeny et al.	
	307	2004/0204639	10-14-2004	Casciani et al.	
	308	2004/0204868	10-14-2004	Maynard, et al.	
	309	2005/0228253	10-13-2005	Debreczeny	
	310	2005/0250997	11-10-2005	Takedo et al.	
	311	2004/0267140	12-30-2004	Ito et al.	
	312	RE36,000	12-22-1998	Swedlow et al.	
	313	RE33,643	07-23-1991	Isacson et al.	

FOREIGN PATENT DOCUMENTS						
Examiner Initials	Cite No.	Foreign Patent Document Country Code-Number-Kind Code Example: JP 1234567	Publication Date MM-DD-YYYY	Name of Patentee or Applicant	Pages, Columns, Lines Where Relevant Passages or Relevant Figures Appear	T ¹
	314					
	315					

Examiner Signature	Date Considered
*Examiner: Initial if reference considered, whether or not citation is in conformance with MPEP 609. Draw line through citation if not in conformance and not considered. Include copy of this form with next communication to applicant.	

T¹ - Place a check mark in this area when an English language Translation is attached.

ALL REFERENCES CONSIDERED EXCEPT WHERE LINED THROUGH. /EB/

INFORMATION DISCLOSURE STATEMENT BY APPLICANT	Application No.	11/366,209
	Filing Date	March 1, 2006
	First Named Inventor	Ammar Al-Ali et al.
	Art Unit	3735
<i>(Multiple sheets used when necessary)</i>		Examiner
SHEET 13 OF 13		Attorney Docket No. MLR.004A

FOREIGN PATENT DOCUMENTS						
Examiner Initials	Cite No.	Foreign Patent Document <i>Country Code-Number-Kind Code</i> Example: JP 1234567	Publication Date MM-DD-YYYY	Name of Patentee or Applicant	Pages, Columns, Lines Where Relevant Passages or Relevant Figures Appear	T ¹
	316					
	317					
	318					

NON PATENT LITERATURE DOCUMENTS			
Examiner Initials	Cite No.	Include name of the author (in CAPITAL LETTERS), title of the article (when appropriate), title of the item (book, magazine, journal, serial, symposium, catalog, etc.), date, page(s), volume-issue number(s), publisher, city and/or country where published.	T ¹
	319		
	320		
	321		
	322		
	323		

2695860
061906

Examiner Signature	Date Considered
<p>*Examiner: Initial if reference considered, whether or not citation is in conformance with MPEP 609. Draw line through citation if not in conformance and not considered. Include copy of this form with next communication to applicant.</p>	

T¹ - Place a check mark in this area when an English language Translation is attached.

ALL REFERENCES CONSIDERED EXCEPT WHERE LINED THROUGH. /EB/

**INFORMATION DISCLOSURE
STATEMENT BY APPLICANT**

(Multiple sheets used when necessary)

SHEET 1 OF 6

Application No.	11/366,209
Filing Date	March 1, 2006
First Named Inventor	Ammar Al-Ali
Art Unit	3735
Examiner	
Attorney Docket No.	MLR.004A

U.S. PATENT DOCUMENTS

Document Number Initials	Cite No.	Document Number Number - Kind Code (if known) Example: 1,234,567 B1	Publication Date MM-DD-YYYY	Name of Patentee or Applicant	Pages, Columns, Lines Where Relevant Passages or Relevant Figures Appear
	1	7,044,918	05/2006	Diab	
	2	7,041,060	05/2006	Flaherty, et al	
	3	7,039,449	05/2006	Al-Ali	
	4	7,030,749	04/2006	Al-Ali	
	5	7,027,849	04/2006	Al-Ali	
	6	7,024,233	04/2006	Al, et al.	
	7	7,015,451	02/2006	Dalke, et al.	
	8	7,003,339	02/2006	Diab, et al.	
	9	7,003,338	02/2006	Weber, et al.	
	10	6,999,904	02/2006	Weber, et al.	
	11	6,996,427	02/2006	Ali, et al.	
	12	6,993,371	01/2006	Kiani, et al.	
	13	6,985,764	01/2006	Mason, et al.	
	14	6,979,812	12/2005	Al-Ali	
	15	6,970,792	11/2005	Diab	
	16	6,961,598	11/2005	Diab	
	17	6,950,687	09/2005	Al-Ali	
	18	6,943,348	09/2005	Coffin, IV	
	19	6,939,305	09/2005	Flaherty, et al.	
	20	6,934,570	08/2005	Kiani, et al.	
	21	6,931,268	08/2005	Kiani-Azarbayjany, et al.	
	22	6,920,345	07/2005	Al-Ali, et al.	
	23	6,898,452	05/2005	Al-Ali, et al.	
	24	6,861,639	03/2005	Al-Ali	
	25	6,852,083	02/2005	Caro, et al.	
	26	6,850,788	02/2005	Al-Ali	
	27	6,850,787	02/2005	Weber, et al.	
	28	6,830,711	12/2004	Mills, et al.	
	29	6,826,419	11/2004	Diab, et al.	

Examiner Signature

Date Considered

*Examiner: Initial if reference considered, whether or not citation is in conformance with MPEP 609. Draw line through citation if not in conformance and not considered. Include copy of this form with next communication to applicant.

T¹ - Place a check mark in this area when an English language Translation is attached.

ALL REFERENCES CONSIDERED EXCEPT WHERE LINED THROUGH. /EB/

INFORMATION DISCLOSURE STATEMENT BY APPLICANT	Application No.	11/366,209
	Filing Date	March 1, 2006
	First Named Inventor	Ammar Al-Ali
	Art Unit	3735
<i>(Multiple sheets used when necessary)</i>	Examiner	
SHEET 2 OF 6	Attorney Docket No.	MLR.004A

U.S. PATENT DOCUMENTS					
Examiner Initials	Cite No.	Document Number Number - Kind Code (if known) Example: 1,234,567 B1	Publication Date MM-DD-YYYY	Name of Patentee or Applicant	Pages, Columns, Lines Where Relevant Passages or Relevant Figures Appear
	30	6,822,564	11/2004	Al-Ali	
	31	6,816,741	11/2004	Diab	
	32	6,813,511	11/2004	Diab, et al.	
	33	6,792,300	09/2004	Diab, et al.	
	34	6,771,994	08/2004	Kiani, et al.	
	35	6,770,028	08/2004	Ali, et al.	
	36	6,760,607	07/2004	Al-Ali	
	37	6,745,060	06/2004	Diab, et al.	
	38	6,735,459	05/2004	Parker	
	39	6,725,075	04/2004	Al-Ali	
	40	6,721,585	04/2004	Parker	
	41	RE38,492	04/2004	Diab, et al.	
	42	6,714,804	03/2004	Al-Ali, et al.	
	43	RE38,476	03/2004	Diab, et al.	
	44	6,699,194	03/2004	Diab, et al.	
	45	6,697,658	02/2004	Al-Ali	
	46	6,697,656	02/2004	Al-Ali	
	47	6,684,091	01/2004	Parker	
	48	6,684,090	01/2004	Ali, et al.	
	49	6,678,543	01/2004	Diab, et al.	
	50	6,671,531	12/2003	Al-Ali, et al.	
	51	6,661,161	12/2003	Lanzo, et al.	
	52	6,658,276	12/2003	Diab, et al.	
	53	6,654,624	11/2003	Diab, et al.	
	54	6,650,917	11/2003	Diab, et al.	
	55	6,643,530	11/2003	Diab, et al.	
	56	6,640,116	10/2003	Diab	
	57	6,632,181	10/2003	Flaherty, et al.	
	58	6,606,511	08/2003	Ali, et al.	

Examiner Signature	Date Considered
<p>*Examiner: Initial if reference considered, whether or not citation is in conformance with MPEP 609. Draw line through citation if not in conformance and not considered. Include copy of this form with next communication to applicant.</p>	

T¹ - Place a check mark in this area when an English language Translation is attached.

ALL REFERENCES CONSIDERED EXCEPT WHERE LINED THROUGH. /EB/

INFORMATION DISCLOSURE STATEMENT BY APPLICANT	Application No.	11/366,209
	Filing Date	March 1, 2006
	First Named Inventor	Ammar Al-Ali
	Art Unit	3735
<i>(Multiple sheets used when necessary)</i>		Examiner
SHEET 3 OF 6		Attorney Docket No. MLR.004A

U.S. PATENT DOCUMENTS					
Examiner Initials	Cite No.	Document Number Number - Kind Code (if known) Example: 1,234,567 B1	Publication Date MM-DD-YYYY	Name of Patentee or Applicant	Pages, Columns, Lines Where Relevant Passages or Relevant Figures Appear
	59	6,597,933	07/2003	Kiani, et al.	
	60	6,595,316	07/2003	Cybulski, et al.	
	61	6,584,336	06/2003	Ali, et al.	
	62	6,580,086	06/2003	Schulz, et al.	
	63	6,542,764	04/2003	Al-Ali, et al.	
	64	6,541,756	04/2003	Schulz, et al.	
	65	6,526,300	02/2003	Kiani, et al.	
	66	6,525,386	02/2003	Mills, et al.	
	67	6,519,487	02/2003	Parker	
	68	6,515,273	02/2003	Al-Ali	
	69	6,501,975	12/2002	Diab, et al.	
	70	6,470,199	10/2002	Kopotic, et al.	
	71	6,463,311	10/2002	Diab	
	72	6,430,525	08/2002	Weber, et al.	
	73	6,397,091	05/2002	Diab, et al.	
	74	6,388,240	05/2002	Schulz, et al.	
	75	6,377,829	04/2002	Al-Ali	
	76	6,371,921	04/2002	Caro, et al.	
	77	6,360,114	03/2002	Diab, et al.	
	78	6,349,228	02/2002	Kiani, et al.	
	79	6,343,224	01/2002	Parker	
	80	6,334,065	12/2001	Al-Ali, et al.	
	81	6,321,100	11/2001	Parker	
	82	6,285,896	09/2001	Tobler, et al.	
	83	6,280,213	08/2001	Tobler, et al.	
	84	6,278,522	08/2001	Lepper, Jr., et al.	
	85	6,263,222	07/2001	Diab, et al.	
	86	6,256,523	07/2001	Diab, et al.	
	87	6,236,872	05/2001	Diab, et al.	

Examiner Signature	Date Considered
<p>*Examiner: Initial if reference considered, whether or not citation is in conformance with MPEP 609. Draw line through citation if not in conformance and not considered. Include copy of this form with next communication to applicant.</p>	

T¹ - Place a check mark in this area when an English language Translation is attached.

ALL REFERENCES CONSIDERED EXCEPT WHERE LINED THROUGH. /EB/

INFORMATION DISCLOSURE STATEMENT BY APPLICANT	Application No.	11/366,209
	Filing Date	March 1, 2006
	First Named Inventor	Ammar Al-Ali
	Art Unit	3735
<i>(Multiple sheets used when necessary)</i>		Examiner
SHEET 4 OF 6		Attorney Docket No. MLR.004A

U.S. PATENT DOCUMENTS					
Examiner Initials	Cite No.	Document Number Number - Kind Code (if known) Example: 1,234,567 B1	Publication Date MM-DD-YYYY	Name of Patentee or Applicant	Pages, Columns, Lines Where Relevant Passages or Relevant Figures Appear
	88	6,229,856	05/2001	Diab, et al.	
	89	6,206,830	03/2001	Diab, et al.	
	90	6,184,521	02/2001	Coffin, IV, et al.	
	91	6,165,005	12/2000	Mills, et al.	
	92	6,157,850	12/2000	Diab, et al.	
	93	6,152,754	11/2000	Gerhardt, et al.	
	94	6,151,516	11/2000	Kiani-Azarbayjany, et al.	
	95	6,144,868	11/2000	Parker	
	96	6,110,522	08/2000	Lepper, Jr., et al.	
	97	6,088,607	07/2000	Diab, et al.	
	98	6,081,735	06/2000	Diab, et al.	
	99	6,067,462	05/2000	Diab, et al.	
	100	6,045,509	04/2000	Caro, et al.	
	101	6,036,642	03/2000	Diab, et al.	
	102	6,027,452	02/2000	Flaherty, et al.	
	103	6,011,986	01/2000	Diab, et al.	
	104	6,002,952	12/1999	Diab, et al.	
	105	5,997,343	12/1999	Mills, et al.	
	106	5,995,855	11/1999	Kiani, et al.	
	107	5,940,182	08/1999	Lepper, Jr., et al.	
	108	5,934,925	08/1999	Tobler, et al.	
	109	5,919,134	07/1999	Diab	
	110	5,904,654	05/1999	Wohltmann, et al.	
	111	5,890,929	04/1999	Mills, et al.	
	112	5,860,919	01/1999	Kiani-Azarbayjany, et al.	
	113	5,833,618	11/1998	Caro, et al.	
	114	5,830,131	11/1998	Caro, et al.	
	115	5,823,950	10/1998	Diab, et al.	
	116	5,810,734	09/1998	Caro, et al.	

Examiner Signature	Date Considered
*Examiner: Initial if reference considered, whether or not citation is in conformance with MPEP 609. Draw line through citation if not in conformance and not considered. Include copy of this form with next communication to applicant.	

T¹ - Place a check mark in this area when an English language Translation is attached.

ALL REFERENCES CONSIDERED EXCEPT WHERE LINED THROUGH. /EB/

INFORMATION DISCLOSURE STATEMENT BY APPLICANT	Application No.	11/366,209
	Filing Date	March 1, 2006
	First Named Inventor	Ammar Al-Ali
	Art Unit	3735
<i>(Multiple sheets used when necessary)</i>		Examiner
SHEET 5 OF 6		Attorney Docket No. MLR.004A

U.S. PATENT DOCUMENTS					
Examiner Initials	Cite No.	Document Number Number - Kind Code (if known) Example: 1,234,567 B1	Publication Date MM-DD-YYYY	Name of Patentee or Applicant	Pages, Columns, Lines Where Relevant Passages or Relevant Figures Appear
	117	5,791,347	08/1998	Flaherty, et al.	
	118	5,785,659	07/1998	Caro, et al.	
	119	5,782,757	07/1998	Diab, et al.	
	120	5,769,785	06/1998	Diab, et al.	
	121	5,760,910	06/1998	Lepper, Jr., et al.	
	122	5,758,644	06/1998	Diab, et al.	
	123	5,743,262	04/1998	Lepper, Jr., et al.	
	124	Des. 393,830	04/1998	Tobler, et al.	
	125	5,685,299	11/1997	Diab, et al.	
	126	5,645,440	07/1997	Tobler, et al.	
	127	5,638,818	06/1997	Diab, et al.	
	128	5,638,816	06/1997	Kiani-Azarbayjany, et al.	
	129	5,632,272	05/1997	Diab, et al.	
	130	5,602,924	02/1997	Durand, et al.	
	131	5,590,649	01/1997	Caro, et al.	
	132	5,562,002	10/1986	Lalin	
	133	5,533,511	07/1996	Kaspari, et al.	
	134	5,494,043	02/1996	O'Sullivan, et al.	
	135	5,490,505	02/1996	Diab, et al.	
	136	5,482,036	01/1996	Diab, et al.	
	137	D363,120	10/1995	Savage, et al.	
	138	5,452,717	09/1995	Branigan, et al.	
	139	D362,063	09/1995	Savage, et al.	
	140	D361,840	08/1995	Savage, et al.	
	141	5,431,170	07/1995	Mathews	
	142	D353,196	12/1994	Savage, et al.	
	143	D353,195	12/1994	Savage, et al.	
	144	5,337,744	08/1994	Branigan	
	145	5,163,438	11/1992	Gordon, et al.	

Examiner Signature	Date Considered
*Examiner: Initial if reference considered, whether or not citation is in conformance with MPEP 609. Draw line through citation if not in conformance and not considered. Include copy of this form with next communication to applicant.	

T¹ - Place a check mark in this area when an English language Translation is attached.

ALL REFERENCES CONSIDERED EXCEPT WHERE LINED THROUGH. /EB/

INFORMATION DISCLOSURE STATEMENT BY APPLICANT	Application No.	11/366,209
	Filing Date	March 1, 2006
	First Named Inventor	Ammar Al-Ali
	Art Unit	3735
<i>(Multiple sheets used when necessary)</i>		Examiner
SHEET 6 OF 6		Attorney Docket No. MLR.004A

U.S. PATENT DOCUMENTS					
Examiner Initials	Cite No.	Document Number Number - Kind Code (if known) Example: 1,234,567 B1	Publication Date MM-DD-YYYY	Name of Patentee or Applicant	Pages, Columns, Lines Where Relevant Passages or Relevant Figures Appear
	146	5,069,213	12/1991	Polczynski	
	147	5,041,187	08/1991	Hink, et al.	
	148	4,964,408	10/1990	Hink, et al.	
	149	4,960,128	10/1990	Gordon, et al.	

2695867
061906

Examiner Signature /Etsub Berhanu/ (07/12/2009)	Date Considered
*Examiner: Initial if reference considered, whether or not citation is in conformance with MPEP 609. Draw line through citation if not in conformance and not considered. Include copy of this form with next communication to applicant.	

T¹ - Place a check mark in this area when an English language Translation is attached.

ALL REFERENCES CONSIDERED EXCEPT WHERE LINED THROUGH. /EB/



INFORMATION DISCLOSURE STATEMENT BY APPLICANT (Multiple sheets used when necessary) SHEET 1 OF 2	Application No.	11/366,209
	Filing Date	March 1, 2006
	First Named Inventor	Al-Ali, et al.
	Art Unit	3735
	Examiner	Unknown
	Attorney Docket No.	MLR.004A

U.S. PATENT DOCUMENTS

Examiner Initials	Cite No.	Document Number Number - Kind Code (if known) Example: 1,234,567 B1	Publication Date MM-DD-YYYY	Name of Patentee or Applicant	Pages, Columns, Lines Where Relevant Passages or Relevant Figures Appear
	1	6,743,172	6/1/04	Blike	
	2	6,611,698	8/26/03	Yamashita et al.	
	3	6,253,097	6/26/01	Aronow et al.	
	4	6,184,521	2/6/01	Coffin IV et al.	
	5	6,122,042	9/19/00	Wunderman et al.	
	6	5,800,348	1/9/98	Kaestle et al.	
	7	5,645,059	7/8/97	Fein et al.	
	8	5,331,549	7/19/94	Crawford Jr.	
	9	5,259,381	11/9/93	Cheung et al.	
	10	5,058,588	10/22/91	Kaestle et al.	
	11	4,986,665	1/22/91	Yamanishi et al.	
	12	4,907,876	3/13/90	Suzuki et al.	
	13	2005/0011488	2/10/05	Al Ali et al.	
	14	2004/0267103	12/30/04	Li Luya et al.	
	15	2004/0262046	12/30/04	Simon et al.	
	16	2004/0158134	8/12/04	Diab et al.	
	17	2004/0147823	7/29/04	Kiani et al.	
	18	2004/0133087	7/8/04	Al Ali et al.	
	19	2004/0081621	4/29/04	Arndt et al.	
	20	2004/0059209	3/25/04	Al Ali et al.	
	21	2004/0034898	2/10/05	Al Ali et al.	
	22	2002/0183819	12/5/02	Struble	
	23	2002/0161291	10/31/02	Kiani et al.	
	24	2002/0038081	3/28/02	Fein et al.	
	25	2002/0021269	2/21/00	Rast	
	26	2001/0044700	11/22/01	Koboyashi et al.	

FOREIGN PATENT DOCUMENTS

Examiner Signature	Date Considered
<p>*Examiner: Initial if reference considered, whether or not citation is in conformance with MPEP 609. Draw line through citation if not in conformance and not considered. Include copy of this form with next communication to applicant.</p>	

T¹ - Place a check mark in this area when an English language Translation is attached.

ALL REFERENCES CONSIDERED EXCEPT WHERE LINED THROUGH. /EB/

INFORMATION DISCLOSURE STATEMENT BY APPLICANT	Application No.	11/366,209	
	Filing Date	March 1, 2006	
	First Named Inventor	Al-Ali, et al.	
	Art Unit	3735	
<i>(Multiple sheets used when necessary)</i>		Examiner	Unknown
SHEET 2 OF 2		Attorney Docket No.	MLR.004A

Examiner Initials	Cite No.	Foreign Patent Document Country Code-Number-Kind Code Example: JP 1234567 A1	Publication Date MM-DD-YYYY	Name of Patentee or Applicant	Pages, Columns, Lines Where Relevant Passages or Relevant Figures Appear	T ¹
	27	WO 00/59374	10/12/00	Scheuing et al.		
	28	WO 98/43071	10/1/98	Baker et al.		
	29	WO 03/068060	8/21/03	Huiku		

NON PATENT LITERATURE DOCUMENTS

Examiner Initials	Cite No.	Include name of the author (in CAPITAL LETTERS), title of the article (when appropriate), title of the item (book, magazine, journal, serial, symposium, catalog, etc.), date, page(s), volume-issue number(s), publisher, city and/or country where published.	T ¹
	30	Patent Cooperation Treaty (PCT) International Search Report; PCT/US 2006/007389; Date of Mailing 7/17/06; Pages 1-9	
	31	PCT International Search Report; PCT/US2006/007537; Date of Mailing 7/17/06; Pages 1-10	
	32	PCT International Search Report; PCT/US2006/007389; Date of Mailing 7/17/06; Pages 1-9	
	33	PCT International Search Report; PCT/US2006/007538; Date of Mailing 7/17/06; Pages 1-9	
	34	PCT International Search Report; PCT/US2006/007958; Date of Mailing 7/17/06; Pages 1-8	
	35	PCT International Search Report; PCT/US2006/007506; Date of Mailing 7/17/06; Pages 1-10	
	36	PCT International Search Report; PCT/US2006/007536; Date of Mailing 7/17/06; Pages 1-9	
	37	PCT International Search Report; PCT/US2006/007540; Date of Mailing 7/17/06; Pages 1-9	
	38	PCT International Search Report; PCT/US2006/007539; Date of Mailing 7/17/06; Pages 1-9	
	39	PCT International Search Report; PCT/US2006/007387; Date of Mailing 7/17/06; Pages 1-9	

3848323
081706

Examiner Signature	/Etsub Berhanu/ (07/12/2009)	Date Considered
*Examiner: Initial if reference considered, whether or not citation is in conformance with MPEP 609. Draw line through citation if not in conformance and not considered. Include copy of this form with next communication to applicant.		

T¹ - Place a check mark in this area when an English language Translation is attached.

ALL REFERENCES CONSIDERED EXCEPT WHERE LINED THROUGH. /EB/

INFORMATION DISCLOSURE STATEMENT

Applicant : Ammar Al-Ali, et al.
 App. No : 11/366,209
 Filed : March 1, 2006
 For : MULTIPLE WAVELENGTH
 SENSOR SUBSTRATE
 Examiner : Winakur, Eric F.
 Art Unit : 3768

Confirmation No.: 2025

**EFS Web Transmission
Certification**

I hereby certify that this correspondence
and all marked attachments are being
transmitted via EFS

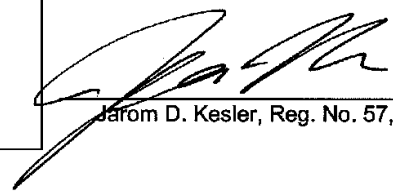

Jarom D. Kesler, Reg. No. 57,046

Commissioner for Patents
P.O. Box 1450
Alexandria, VA 22313-1450

Dear Sir:

Enclosed for filing in the above-identified application is a PTO/SB/08 Equivalent listing 5 references to be considered by the Examiner. Also enclosed are 2 foreign patent references and/or non-patent literature as listed on the Information Disclosure Statement.

This Information Disclosure Statement is being filed before the receipt of a first Office Action on the merits, and presumably no fee is required. If a first Office Action on the merits was mailed before the mailing date of this Statement, the Commissioner is authorized to charge the fee set forth in 37 C.F.R. § 1.17(p) to Deposit Account No. 11-1410.

Respectfully submitted,
KNOBBE, MARTENS, OLSON & BEAR, LLP

Dated: 2/20/07

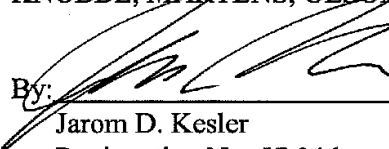
By: 
 Jarom D. Kesler
 Registration No. 57,046
 Attorney of Record
 Customer No. 20,995
 (949) 760-0404

INFORMATION DISCLOSURE STATEMENT BY APPLICANT	Application No.	11/366,209
	Filing Date	March 1, 2006
	First Named Inventor	Ammar Al-Ali
	Art Unit	3768
<i>(Multiple sheets used when necessary)</i>	Examiner	Winakur, Eric F.
SHEET 1 OF 1	Attorney Docket No.	MLR.004A

U.S. PATENT DOCUMENTS					
Examiner Initials	Cite No.	Document Number Number - Kind Code (if known) Example: 1,234,567 B1	Publication Date MM-DD-YYYY	Name of Patentee or Applicant	Pages, Columns, Lines Where Relevant Passages or Relevant Figures Appear
	1	US 2002/156353 A1	10-24-2002	Eric Russell Larson	
	2	US 2001/045532 A1	11-29-2001	Charles E. Schulz, et al.	
	3	US 6,285,895 B1	09-04-2001	Kimmo Juhani Ristolainen, et al.	

FOREIGN PATENT DOCUMENTS						
Examiner Initials	Cite No.	Foreign Patent Document Country Code-Number-Kind Code Example: JP 1234567 A1	Publication Date MM-DD-YYYY	Name of Patentee or Applicant	Pages, Columns, Lines Where Relevant Passages or Relevant Figures Appear	T ¹

NON PATENT LITERATURE DOCUMENTS			
Examiner Initials	Cite No.	Include name of the author (in CAPITAL LETTERS), title of the article (when appropriate), title of the item (book, magazine, journal, serial, symposium, catalog, etc.), date, page(s), volume-issue number(s), publisher, city and/or country where published.	T ¹
	4	International Search Report for PCT/US2006/007516, mailed on 01-11-2007, in 4 pages.	
	5	SCHMITT, JOSEPH M.; ZHOU, GUAN-XIONG; MILLER, JUSTIN, <u>Measurement of Blood Hematocrit by Dual-wavelength Near-IR Photoplethysmography</u> , published May 1992, Proc. SPIE Vol.1641, p.150-161, Physiological Monitoring and Early Detection Diagnostic Methods, Thomas S. Mang; Ed. (SPIE homepage), in 12 pages.	

3427772:cy
021407

Examiner Signature	Date Considered
<p>*Examiner: Initial if reference considered, whether or not citation is in conformance with MPEP 609. Draw line through citation if not in conformance and not considered. Include copy of this form with next communication to applicant.</p>	

T¹ - Place a check mark in this area when an English language Translation is attached.

Electronic Acknowledgement Receipt

EFS ID:	1529104
Application Number:	11366209
International Application Number:	
Confirmation Number:	2025
Title of Invention:	Multiple wavelength sensor substrate
First Named Inventor/Applicant Name:	Ammar Al-Ali
Customer Number:	20995
Filer:	Jarom D. Kesler/Kehinde Jegede
Filer Authorized By:	Jarom D. Kesler
Attorney Docket Number:	MLR.004A
Receipt Date:	20-FEB-2007
Filing Date:	01-MAR-2006
Time Stamp:	16:13:57
Application Type:	Utility

Payment information:

Submitted with Payment	no
------------------------	----

File Listing:

Document Number	Document Description	File Name	File Size(Bytes)	Multi Part /.zip	Pages (if appl.)
1	Information Disclosure Statement (IDS) Filed	MLR004aIDS.pdf	99814	no	2

Warnings:

Information:					
This is not an USPTO supplied IDS fillable form					
2	NPL Documents	MLR004aNonPatRef1.pdf	762049	no	12
Warnings:					
Information:					
3	NPL Documents	MLR004aNonPatentRef2.pdf	172348	no	4
Warnings:					
Information:					
Total Files Size (in bytes):			1034211		
<p>This Acknowledgement Receipt evidences receipt on the noted date by the USPTO of the indicated documents, characterized by the applicant, and including page counts, where applicable. It serves as evidence of receipt similar to a Post Card, as described in MPEP 503.</p> <p><u>New Applications Under 35 U.S.C. 111</u> If a new application is being filed and the application includes the necessary components for a filing date (see 37 CFR 1.53(b)-(d) and MPEP 506), a Filing Receipt (37 CFR 1.54) will be issued in due course and the date shown on this Acknowledgement Receipt will establish the filing date of the application.</p> <p><u>National Stage of an International Application under 35 U.S.C. 371</u> If a timely submission to enter the national stage of an international application is compliant with the conditions of 35 U.S.C. 371 and other applicable requirements a Form PCT/DO/EO/903 indicating acceptance of the application as a national stage submission under 35 U.S.C. 371 will be issued in addition to the Filing Receipt, in due course.</p> <p><u>New International Application Filed with the USPTO as a Receiving Office</u> If a new international application is being filed and the international application includes the necessary components for an international filing date (see PCT Article 11 and MPEP 1810), a Notification of the International Application Number and of the International Filing Date (Form PCT/RO/105) will be issued in due course, subject to prescriptions concerning national security, and the date shown on this Acknowledgement Receipt will establish the international filing date of the application.</p>					

10/21



Please Direct All Correspondence to Customer Number **20995**

**TRANSMITTAL LETTER
INFORMATION DISCLOSURE STATEMENT**

Applicant : Al-Ali, et al.
App. No : 11/366,209
Filed : March 1, 2006
For : MULTIPLE WAVELENGTH SENSOR
SUBSTRATE
Examiner : Unknown
Art Unit : 3735

CERTIFICATE OF MAILING

I hereby certify that this correspondence and all marked attachments are being deposited with the United States Postal Service as first-class mail in an envelope addressed to: Commissioner for Patents, P.O. Box 1450, Alexandria, VA 22313-1450, on

August 25, 2006
(Date)

[Signature]
Jarom D. Kessler, Reg. No. 57,046

Mail Stop Amendment
Commissioner for Patents
P.O. Box 1450
Alexandria, VA 22313-1450

Dear Sir:

Enclosed for filing in the above-identified application are:

- (X) An Information Disclosure Statement and PTO/SB/08 equivalent listing references for consideration:
 - (X) Listing 39 references.
 - (X) Enclosing 13 references.
- (X) The Commissioner is hereby authorized to charge any additional fees which may be required, or credit any overpayment, to Account No. 11-1410.
- (X) Return prepaid postcard.

[Signature]
Jarom D. Kessler
Registration No. 57,046
Attorney of Record
Customer No. 20,995
(949) 760-0404



INFORMATION DISCLOSURE STATEMENT

Applicant : Al-Ali, et al.
 App. No : 11/366,209
 Filed : March 1, 2006
 For : MULTIPLE WAVELENGTH SENSOR
 SUBSTRATE
 Examiner : Unknown
 Art Unit : 3735

CERTIFICATE OF MAILING

I hereby certify that this correspondence and all marked attachments are being deposited with the United States Postal Service as first-class mail in an envelope addressed to: Commissioner for Patents, P.O. Box 1450, Alexandria, VA 22313-1450, on

August 25, 2006

(Date)

 Jarom Kesler, Reg. No. 57,046

Mail Stop Amendment
 Commissioner for Patents
 P.O. Box 1450
 Alexandria, VA 22313-1450

Dear Sir:

Enclosed for filing in the above-identified application is a PTO/SB/08 Equivalent listing 39 references to be considered by the Examiner. Also enclosed are 13 foreign patent references and/or non-patent literature as listed on the Information Disclosure Statement.

This Information Disclosure Statement is being filed before the mailing date of a final action and before the mailing date of a Notice of Allowance.

CERTIFICATION UNDER 37 C.F.R. § 1.97(e)(1)

I hereby certify that each item of information contained in this Statement was first cited in a communication from a foreign Patent Office in a counterpart foreign application not more than three months prior to the filing of this Information Disclosure Statement.

Thus, no fee is required as set forth in 37 C.F.R. § 1.97(c).

Respectfully submitted,
 KNOBBE, MARTENS, OLSON & BEAR, LLP

Dated: 8/25/06

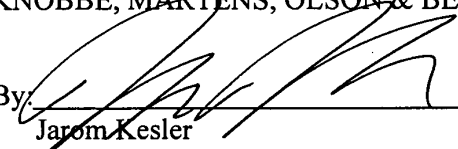
By: 
 Jarom Kesler
 Registration No. 57,046
 Attorney of Record
 Customer No. 20,995
 (949) 760-0404



INFORMATION DISCLOSURE STATEMENT BY APPLICANT (Multiple sheets used when necessary)	Application No.	11/366,209
	Filing Date	March 1, 2006
	First Named Inventor	Al-Ali, et al.
	Art Unit	3735
SHEET 1 OF 2	Examiner	Unknown
	Attorney Docket No.	MLR.004A

U.S. PATENT DOCUMENTS

Examiner Initials	Cite No.	Document Number Number - Kind Code (if known) Example: 1,234,567 B1	Publication Date MM-DD-YYYY	Name of Patentee or Applicant	Pages, Columns, Lines Where Relevant Passages or Relevant Figures Appear
	1	6,743,172	6/1/04	Blike	
	2	6,611,698	8/26/03	Yamashita et al.	
	3	6,253,097	6/26/01	Aronow et al.	
	4	6,184,521	2/6/01	Coffin IV et al.	
	5	6,122,042	9/19/00	Wunderman et al.	
	6	5,800,348	1/9/98	Kaestle et al.	
	7	5,645,059	7/8/97	Fein et al.	
	8	5,331,549	7/19/94	Crawford Jr.	
	9	5,259,381	11/9/93	Cheung et al.	
	10	5,058,588	10/22/91	Kaestle et al.	
	11	4,986,665	1/22/91	Yamanishi et al.	
	12	4,907,876	3/13/90	Suzuki et al.	
	13	2005/0011488	2/10/05	Al Ali et al.	
	14	2004/0267103	12/30/04	Li Luya et al.	
	15	2004/0262046	12/30/04	Simon et al.	
	16	2004/0158134	8/12/04	Diab et al.	
	17	2004/0147823	7/29/04	Kiani et al.	
	18	2004/0133087	7/8/04	Al Ali et al.	
	19	2004/0081621	4/29/04	Arndt et al.	
	20	2004/0059209	3/25/04	Al Ali et al.	
	21	2004/0034898	2/10/05	Al Ali et al.	
	22	2002/0183819	12/5/02	Struble	
	23	2002/0161291	10/31/02	Kiani et al.	
	24	2002/0038081	3/28/02	Fein et al.	
	25	2002/0021269	2/21/00	Rast	
	26	2001/0044700	11/22/01	Koboyashi et al.	

FOREIGN PATENT DOCUMENTS

Examiner Signature	Date Considered
*Examiner: Initial if reference considered, whether or not citation is in conformance with MPEP 609. Draw line through citation if not in conformance and not considered. Include copy of this form with next communication to applicant.	

T¹ - Place a check mark in this area when an English language Translation is attached.

INFORMATION DISCLOSURE STATEMENT BY APPLICANT	Application No.	11/366,209	
	Filing Date	March 1, 2006	
	First Named Inventor	Al-Ali, et al.	
	Art Unit	3735	
<i>(Multiple sheets used when necessary)</i>		Examiner	Unknown
SHEET 2 OF 2		Attorney Docket No.	MLR.004A

Examiner Initials	Cite No.	Foreign Patent Document Country Code-Number-Kind Code Example: JP 1234567 A1	Publication Date MM-DD-YYYY	Name of Patentee or Applicant	Pages, Columns, Lines Where Relevant Passages or Relevant Figures Appear	T ¹
	27	WO 00/59374	10/12/00	Scheuing et al.		
	28	WO 98/43071	10/1/98	Baker et al.		
	29	WO 03/068060	8/21/03	Huiku		

NON PATENT LITERATURE DOCUMENTS						
Examiner Initials	Cite No.	Include name of the author (in CAPITAL LETTERS), title of the article (when appropriate), title of the item (book, magazine, journal, serial, symposium, catalog, etc.), date, page(s), volume-issue number(s), publisher, city and/or country where published.				T ¹
	30	Patent Cooperation Treaty (PCT) International Search Report; PCT/US 2006/007389; Date of Mailing 7/17/06; Pages 1-9				
	31	PCT International Search Report; PCT/US2006/007537; Date of Mailing 7/17/06; Pages 1-10				
	32	PCT International Search Report; PCT/US2006/007388; Date of Mailing 7/17/06; Pages 1-9				
	33	PCT International Search Report; PCT/US2006/007538; Date of Mailing 7/17/06; Pages 1-9				
	34	PCT International Search Report; PCT/US2006/007958; Date of Mailing 7/17/06; Pages 1-8				
	35	PCT International Search Report; PCT/US2006/007506; Date of Mailing 7/17/06; Pages 1-10				
	36	PCT International Search Report; PCT/US2006/007536; Date of Mailing 7/17/06; Pages 1-9				
	37	PCT International Search Report; PCT/US2006/007540; Date of Mailing 7/17/06; Pages 1-9				
	38	PCT International Search Report; PCT/US2006/007539; Date of Mailing 7/17/06; Pages 1-9				
	39	PCT International Search Report; PCT/US2006/007387; Date of Mailing 7/17/06; Pages 1-9				

3848323
081706

Examiner Signature	Date Considered
*Examiner: Initial if reference considered, whether or not citation is in conformance with MPEP 609. Draw line through citation if not in conformance and not considered. Include copy of this form with next communication to applicant.	

T¹ - Place a check mark in this area when an English language Translation is attached.



INTERNATIONAL APPLICATION PUBLISHED UNDER THE PATENT COOPERATION TREATY (PCT)

<p>(51) International Patent Classification ⁷ : A61B 5/00</p>	<p>A1</p>	<p>(11) International Publication Number: WO 00/59374 (43) International Publication Date: 12 October 2000 (12.10.00)</p>
<p>(21) International Application Number: PCT/US00/09502 (22) International Filing Date: 7 April 2000 (07.04.00) (30) Priority Data: 60/128,367 8 April 1999 (08.04.99) US (71) Applicant (for all designated States except US): SOMANETICS CORPORATION [US/US]; 1653 East Maple Road, Troy, MI 48083-4208 (US). (72) Inventors; and (75) Inventors/Applicants (for US only): SCHEUING, Richard, S. [US/US]; 441 Farmridge Court, Rochester Hills, MI 48307 (US). YOUNGBLOOD, James, H. [US/US]; 333 Hillwood, White Lake, MI 48383 (US). (74) Agent: CARRIER, Robert, J.; Price, Heneveld, Cooper, DeWitt & Litton, 695 Kenmoor, S.E., P.O. Box 2567, Grand Rapids, MI 49501 (US).</p>		<p>(81) Designated States: AE, AG, AL, AM, AT, AU, AZ, BA, BB, BG, BR, BY, CA, CH, CN, CR, CU, CZ, DE, DK, DM, DZ, EE, ES, FI, GB, GD, GE, GH, GM, HR, HU, ID, IL, IN, IS, JP, KE, KG, KP, KR, KZ, LC, LK, LR, LS, LT, LU, LV, MA, MD, MG, MK, MN, MW, MX, NO, NZ, PL, PT, RO, RU, SD, SE, SG, SI, SK, SL, TJ, TM, TR, TT, TZ, UA, UG, US, UZ, VN, YU, ZA, ZW, ARIPO patent (GH, GM, KE, LS, MW, SD, SL, SZ, TZ, UG, ZW), Eurasian patent (AM, AZ, BY, KG, KZ, MD, RU, TJ, TM), European patent (AT, BE, CH, CY, DE, DK, ES, FI, FR, GB, GR, IE, IT, LU, MC, NL, PT, SE), OAPI patent (BF, BJ, CF, CG, CI, CM, GA, GN, GW, ML, MR, NE, SN, TD, TG).</p> <p>Published <i>With international search report. Before the expiration of the time limit for amending the claims and to be republished in the event of the receipt of amendments.</i></p>

(54) Title: PATIENT SENSOR FOR CLINICAL SPECTROPHOTOMETRIC APPARATUS

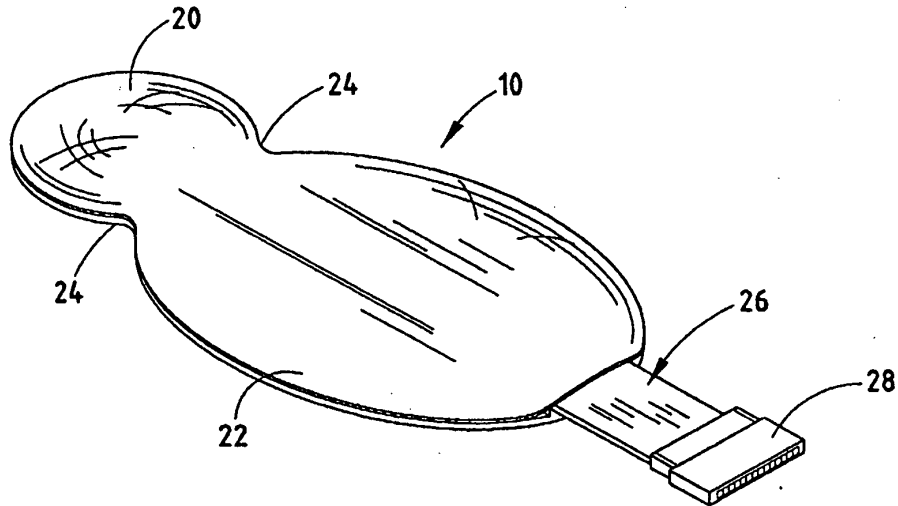

(57) Abstract

This invention is a small, and lightweight spectrophotometric sensor which is particularly, but not necessarily exclusively, useful in cerebral oximetry incorporates a flex circuit (26) having surface mounted electro-optical components that are electrically coupled to conductive traces carried on the flex circuit. At least some such components have an integrally attached rigid, and opaque light passage defining structure which may include a collar-like member, and is preferably a molded element that is "overmolded" upon the electro-optical component. The flex circuit includes a thin elongated member which includes alternate coatings of conductive, and non-conductive material over the conductive traces to provide electrical insulation, and electromagnetic shielding. The conductive traces are connected to short electrical leads extending outwardly from the sensor for only a brief distance, terminated by a manually connectable, and disconnected connector member. The flex circuit is mounted on a soft, thin, opaque, foam body (12), and covered by a thin protective layer (16).

FOR THE PURPOSES OF INFORMATION ONLY

Codes used to identify States party to the PCT on the front pages of pamphlets publishing international applications under the PCT.

AL	Albania	ES	Spain	LS	Lesotho	SI	Slovenia
AM	Armenia	FI	Finland	LT	Lithuania	SK	Slovakia
AT	Austria	FR	France	LU	Luxembourg	SN	Senegal
AU	Australia	GA	Gabon	LV	Latvia	SZ	Swaziland
AZ	Azerbaijan	GB	United Kingdom	MC	Monaco	TD	Chad
BA	Bosnia and Herzegovina	GE	Georgia	MD	Republic of Moldova	TG	Togo
BB	Barbados	GH	Ghana	MG	Madagascar	TJ	Tajikistan
BE	Belgium	GN	Guinea	MK	The former Yugoslav Republic of Macedonia	TM	Turkmenistan
BF	Burkina Faso	GR	Greece			TR	Turkey
BG	Bulgaria	HU	Hungary	ML	Mali	TT	Trinidad and Tobago
BJ	Benin	IE	Ireland	MN	Mongolia	UA	Ukraine
BR	Brazil	IL	Israel	MR	Mauritania	UG	Uganda
BY	Belarus	IS	Iceland	MW	Malawi	US	United States of America
CA	Canada	IT	Italy	MX	Mexico	UZ	Uzbekistan
CF	Central African Republic	JP	Japan	NE	Niger	VN	Viet Nam
CG	Congo	KE	Kenya	NL	Netherlands	YU	Yugoslavia
CH	Switzerland	KG	Kyrgyzstan	NO	Norway	ZW	Zimbabwe
CI	Côte d'Ivoire	KP	Democratic People's Republic of Korea	NZ	New Zealand		
CM	Cameroon			PL	Poland		
CN	China	KR	Republic of Korea	PT	Portugal		
CU	Cuba	KZ	Kazakistan	RO	Romania		
CZ	Czech Republic	LC	Saint Lucia	RU	Russian Federation		
DE	Germany	LI	Liechtenstein	SD	Sudan		
DK	Denmark	LK	Sri Lanka	SE	Sweden		
EE	Estonia	LR	Liberia	SG	Singapore		

PATIENT SENSOR FOR CLINICAL
SPECTROPHOTOMETRIC APPARATUS

BACKGROUND OF THE INVENTION

5 This invention relates generally to spectrophotometric devices and apparatus,
particularly those used for medical purposes, for non-invasively monitoring or otherwise
obtaining data from patients or other test subjects by passing selected light spectra
through portions of the patient anatomy and monitoring the resulting light to obtain data
based on spectrally related absorption by particular biologic substances which reveal
10 internal physiological conditions.

 More particularly, the invention relates to the sensors which are used to produce
and administer the selected light spectra, and to detect the resultant light emanating from
the test subject after it has transmitted the anatomical portion under test. Still more
particularly, the invention pertains to sensors of this basic nature which comprise soft,
15 light-weight, compliant members which carry the necessary electro-optical components
(*e.g.*, emitters, detectors, and the like) and which are applied to a selected area or
location on the patient/test subject in a manner which holds the electro-optical
components in their desired positions relative to the patient/test subject, *e.g.*, normally
in direct light-tight contact with the skin.

20 Many different versions and types of such sensors have been developed over the
past decade or thereabouts, during which medically-related spectrophotometric devices
have been developed and have gained increasing usage in hospitals and other such
clinical locations. Many or most such previously developed sensors pertain to pulse
oximeters, which are used to obtain a measure of arterial hemoglobin oxygen saturation
25 on an ongoing, *in vivo* basis, most typically by attaching the sensor to the patient's
finger, ear lobe, or the like. Other types of such sensors for using the broad underlying
spectrophotometric principals to accomplish various other novel results have also been
developed or proposed previously, particularly by Somanetics Corporation of Troy
Michigan, the Applicant herein, which has developed a non-invasive spectrophotometric
30 cerebral oximeter. That device operates on a non-pulsatile basis to compute oxygen
saturation in the brain by mounting one or more sensors on the forehead and using
selected light wavelengths in the near infrared/red bandwidth to transmit brain tissue
underlying the forehead and detect spectral absorption of the selected light wavelengths
by the blood present in that area. In this regard, reference is made to Applicant's prior

U.S. Patent Nos. 5,795,292, 5,697,367, 5,584,296, 5,482,034, 5,465,714, and 5,217,013, relating to various aspects of this development and its associated apparatus.

Due to the emphasis on sanitation rigorously followed in hospitals and other such health facilities, the standard operating protocol is the utilization of single-use devices and equipment which comes in a sterilized container and is thrown away after use, or even after the container is opened. That same protocol has been followed in the use of spectrophotometric devices such as pulse oximeters and the like, as well as in cerebral oximeters, *i.e.*, the sensors are thrown away after a single use. This of course introduces a significant cost factor, and with the increasing emphasis on cost reduction in medical procedures there is a corresponding emphasis on the design and manufacture of equipment which is more economical to produce and correspondingly less wasteful when discarded after only a single use. At the same time, there is also an increased emphasis on the design and manufacture of better and more capable as well as more reliable componentry, which is usually contradictory to the economy paradigm.

SUMMARY OF THE INVENTION

The present invention satisfies both of the above-stated objectives by the provision of an improved spectrophotometric sensor which is particularly (but not necessarily exclusively) useful in cerebral oximetry. In satisfying these dual objectives of economy and performance, the improved sensor provided herewith comprises a less expensive but equally or even more reliable device, which is lighter in weight than predecessor devices yet nonetheless produces the same high level of operating efficiency and accuracy possessed by previous such devices; in fact, the present invention provides improvements in both such areas due to the novel and highly effective structure and method of manufacture made possible by and in accordance with the invention.

More particularly, the present invention provides an optimally small and lightweight spectrophotometric sensor which incorporates a flex circuit having surface-mounted electro-optical components that are electrically coupled to conductive traces carried on the flex circuit, wherein at least some such components have an integrally attached rigid and opaque light passage-defining structure which may comprise a collar-like member preferably a molded element that is "overmolded" upon the electro-optical component. In this aspect, the invention provides a spectrophotometric sensor of the type just noted having an electro-optical component which is embedded in a generally rigid and opaque light-passage structure comprising an aperture that is formed in place

upon the embedded electro-optical component. Preferably, the conductive traces of the flex circuit are connected to short electrical leads extending outwardly from the sensor for only a brief distance and terminated there by a manually connectable and disconnectable connector member.

5 Furthermore, the invention provides a method of conducting spectrophotometric procedures by use of an electro-optical sensor and a signal processing unit, in which the sensor is applied to the test subject and electrically connected to the processing unit by a coupling carried by and located close to the sensor, said coupling being releasably connectable to a reusable high-quality electrical cable having conductors extending to
10 and connected to the processing unit, to reduce sensor cost, weight, and motion artifact effects. Also provided is a method of manufacturing a spectrophotometric sensor by automated machine operation, including the steps of using a thin flexible substrate which carries thin conductive traces on at least one side, placing electro-optical components in precise predetermined positions on said substrate by using robotic apparatus, and
15 establishing secure electrical connections between said components and said conductive traces by automated means, *e.g.*, by conveying the substrate and placed components through a solder reflow oven, and by using conductive adhesive between said traces and said components.

BRIEF DESCRIPTION OF THE DRAWINGS

20 Fig. 1 is a perspective view showing the basic appearance and nature of a preferred embodiment of the invention;

Fig. 2 is an exploded perspective view showing the components making up the structure of Fig. 1;

25 Fig. 3 is an overhead plan view showing some of the assembled components of the sensor in place, with others removed;

Fig. 4 is an overhead plan view showing one preferred embodiment of the flex circuit used in the sensor;

Fig. 5 is an overhead plan view showing the main body component of the sensor alone, prior to assembly;

30 Fig. 6 is an enlarged side elevational view showing a preferred embodiment of the flex circuit and assembled components;

Fig. 7 is a longitudinal central sectional view of the assembled sensor;

Fig. 8 is an enlarged fragmentary sectional view of the portion circled in Fig. 7 and label "VIII";

Fig. 9 is a enlarged perspective view showing a preferred embodiment of an electro-optical component as utilized in the sensor;

5 Fig. 10 is a further enlarged cross-sectional side elevation taken along the plane X-X of Fig. 9; and

Fig. 11 is a further enlarged cross-sectional side elevation taken along the plane XI-XI of Fig. 9.

DESCRIPTION OF PREFERRED EMBODIMENTS

10 The basic appearance and nature of a preferred embodiment 10 of the invention is illustrated in an overall manner in Fig. 1 and in further detail in Figs. 2, 7, and 8, from which it will be seen that this preferred embodiment is a composite device comprising a plurality of superimposed layers which are stacked one upon the other and adhesively or otherwise secured together into a composite, laminated structure. As best illustrated in
15 Figs. 1 and 2, the sensor 10 preferably has an overall shape analogous to a "figure 8" or "snowman," having a first, smaller rounded portion 20 at one end and a second, larger rounded portion 22 at the other end, with a narrow waist portion 24 therebetween. A flat "flex circuit" 26 which protrudes from the larger end 22 carries a plurality of electrical traces (noted further below) that are terminated by an electrical connector 28
20 of a generally conventional nature, by which the sensor 10 may be connected to and disconnected from a spectrophotometric device such as an oximeter, by means of an electrical cable extending therefrom and having a corresponding and cooperating plug or other such connector part at its end (not specifically illustrated).

As illustrated in Figs. 2, 7, and 8 the various layers making up sensor 10 include
25 a principal body portion 12, which preferably comprises a softly resilient but firm molded foam member having certain transverse apertures 56, recesses 58, and other shaped configurations, and preferably made of a conductive polymeric material such as polyethylene. In a specific preferred embodiment, body 12 may be approximately one-tenth to two-tenths inches thick at its thickest point. Immediately atop the main body portion 12 is a layer of adhesive (or thin "double-sided" adhesive tape film) 13, and a
30 shielding layer 14, which preferably comprises copper-impregnated ripstop nylon approximately .005-.010 inches thick, both of which have substantially the same arrangement of apertures and recesses as those formed in the adjacent side of the foam

body 12 so as to register directly therewith when the adhesive layer 13 and shielding layer 14 are in place upon body 12. Atop the shielding layer 14 is the aforementioned flex circuit 26, whose surface-mounted electro-optical components fit closely inside the aforementioned registering apertures in the shielding layer 14, adhesive layer 13 and
5 main body 12. Over the entire upper surface of main body 12, and covering it as well as shielding layer 14 and the flex circuit 26, is a relatively thin outer cover layer 16, which is preferably of polymeric foam or the like, preferably opaque or substantially opaque, and preferably adhesively secured in place on body 12 to hold the component layers under it securely together as well as provide a finished appearance. Fig. 3 is a top plan
10 view of this layered structure with cover layer 16 removed, showing flex circuit 26 in place atop shielding layer 14 (which covers adhesive layer 13).

On the opposite side of the body 12 from the component layers noted above is one or more layers of electrically conductive adhesive 18a (Figs. 2, 7, and 8) and, directly adjacent and upon that, a protective outer liner layer 18b which should have a
15 readily releasable surface characteristic, *e.g.*, silicone-coated polymeric sheet, so that it may be easily and quickly removed from the adhesive layer 18a for use of the sensor 10 by adhesively securing the latter to the forehead or other selected surface area of the patient or test subject by means of the conductive adhesive 18a. Adhesive layer(s) 18a may advantageously be conductive PSA such as "Arclad 8006," by Adhesives Research,
20 Inc.

The overall nature and certain details or features of the flex circuit 26 are best seen in Figs. 4 and 6. Basically, this component comprises a flexible substrate 30 which carries a plurality of electrically conductive traces 32, a light-emitter component
grouping 34, light-detectors 36 (preferably, at least two, carried at different spacings
25 from the emitter 34), a programmed calibration memory chip 38, and the aforementioned connector 28. More particularly considered, the flexible substrate 30 preferably includes, in addition to the traces 32, a plurality of additional layers 40, 42, and 44 superimposed over one another on each side of the substrate. These layers may be and preferably are very thin (on the order of one mil thick each) coatings which are
30 screen-printed or otherwise applied atop one another. The layers 40 applied directly to each side of the flexible substrate 30 (and atop the conductive traces 32) are of a non-conductive, electrically insulative material, and they are also preferably of an opaque white coloration, so as to be optically shielding as well as electrically insulative. The

layers 42 applied atop the insulating layers 40 preferably comprise screen-printed conductive silver or the like, to function as an electromagnetic shield, and the outer layers 44, applied over the shielding layers 42, preferably comprise another insulating layer of non-conductive, opaque white material.

5 In what is at least one of the most preferred embodiments, the flexible substrate 30 may comprise the polyimide sheet material known commercially as "Kapton®" (trademark of Dupont Company), on the order of about .005 -- .015 inches thick in this embodiment; however, other synthetic sheet materials may also be utilized, including
10 more flexible materials such as polyester compounds (including the polyester derivative known as "PEN" (Pentech), which will withstand higher temperatures than many other polyesters), such materials all being electrically non-conductive. The conductive traces 32 applied on at least one side of substrate 30 are preferably copper in the case of Kapton® substrates, (which are somewhat stronger and more heavy-duty than the polyesters), on the order of .0003 inches thick, and covered by tin plate in exposed
15 areas. Particularly located open (uncoated) "window" areas are left in the insulating and conductive shielding layers 40, 42, and 44 in the immediate area where the emitters 34, detectors 36, and memory chip 38 are to be located, to permit the desired electrical connections to be made between the terminals 48 of the components 34, 36, and 38 and the conductive traces 32.

20 Where the sensor configuration described above is utilized, these electrical connections may be made by silk-screening or otherwise applying solder paste to the specific area on the traces 32 where each such connection is to be made, placing the components 34, 36, 38 precisely in the desired position (by "pick and place", automated robotic apparatus) and using a contact adhesive to temporarily hold the components in
25 this desired placement while the substrate 30 and attached components are conveyed through an oven that is sufficiently hot to melt the solder paste and establish the desired electrical connection without damaging the components, conductive strips or substrate (*i.e.*, about 175°C or less). Where other less rugged materials are used for the substrate 30 (such as polyester), this manufacturing method may be too demanding, but the
30 conductive traces 32 may then be of silver or other conductive ink, printed in place, and the connections between these printed traces and the component terminals may be accomplished by use of conductive adhesives, thereby avoiding the use of hot solder reflow ovens and the like.

The components referred to above as the "emitter" 34 and "detectors" 36 are shown in more detail in Figs. 8, 9, and 10, as well as in Fig. 6, which illustrates the same mounted upon the substrate 30. As noted above, the emitter 34 comprises a selected grouping of wavelength-specific light-emitting components such as LEDs, and the detectors 36 comprise light-sensors such as photodiodes, which provide an electrical output whose magnitude is representative of the light intensity received by them on a real-time basis. In and of themselves, such electro-optical components (now often referred to as "optodes") are very small cubically-shaped solid-state components (indicated at 46 in Fig. 10), with laterally extending electrical terminals 48 protruding therefrom. In accordance with the present invention, each of the electro-optical components 46 is initially encapsulated in a clear epoxy which is preferably applied by the process known as transfer molding, at temperatures of about 150°C or less (to protect the components), to protectively cover each electro-optical component and seal it from moisture, *etc.*, with the electrical connection terminals 48 extending outwardly from the encapsulated component. (The electro-optical component 46 may be supplied in a form by which the component itself is mounted on a metal "lead frame" having integral strip-like projections which form the terminals 48, in which event the component and lead frame are both encapsulated except for the terminals.)

The epoxy-embedded optode 46 thus forms a protected assembly 50 which lends itself well to mechanical handling and other assembly techniques. In accordance with the invention, assembly 50 is overmolded to provide a rigid, windowed outer portion 52 (Fig. 10), for example by using the synthetic compound known as "GE/Ultem" no. 1000F-7101 (available from General Electric Corporation) or other opaque plastic which should be moldable at a sufficiently low temperature to avoid damage to the optode and its embedding material and also capable of withstanding the aforementioned subsequent solder reflow process without damage. Thus, the overmolded component assembly 50, 52 is the actual component which is mounted in place upon the flexible substrate 30 in the particular preferred embodiment under discussion, and it lends itself well to this process due to its size and regulated shape as well as its capability of being handled without damage by mechanical means. The overmolded exterior 52 is preferably opaque and essentially rigid, and it has a window-like opening on one side defined by walls 54, through which light may pass to or from the electro-optical component 46.

The window walls 54 of overmolded cover 52 provide an essentially non-distortable light passage of uniform and consistent shape and dimensions which is not subject to deformation or other such shape changes during use of the sensor, as for example when the sensor is applied to the patient or test subject and pressed firmly into place in a manner which bends or compresses portions of the compliant foam body 12. Also, the walls 54 block ambient light from reaching the sensors, particularly where their outer ends lie in direct contact with the subject to be tested, and the overmolded assembly lends itself well to the automated pick and place manufacturing procedure referred to above, which involves robotic machinery whose use contributes significantly to accurate and consistent component placement at reduced cost. Of course, the bottom extremity of the overmolded electro-optical assembly is the surface applied to the flexible substrate 30 and which carries the adhesive which secures the component in place for soldering, and the connection terminals 48 are offset and configured so that their end extremities basically lie in the same plane as the bottom of the overmolding 52, which is directly adjacent and contiguous to, and substantially the same plane as that occupied by the conductive traces 32, on which the solder paste mentioned previously is applied. It should be pointed out that (as shown in Figs. 9, 10, and 11) the window 54 defined by the overmolding 52 preferably corresponds to and has the same shape as those formed by the molded light guides and optode receptacles disclosed in Applicant's prior U.S. Patent No. 5,465,714, to provide the benefits described therein and broadly disclosed in Applicant's U.S. Patent No. 5,584,296.

Fig. 6 illustrates the assembly produced by mounting the overmolded electro-optical units 34, 36 on the flexible substrate 30, as discussed above, and also shows the calibration memory chip 38 mounted on substrate 30 in essentially this same manner. That is, while memory chip 38 does not necessarily embody the embedded or overmolded structures discussed above in connection with Figs. 9, 10, and 11, it does have projecting electrical terminals which are soldered (or otherwise connected) to the conductive traces 32 in the same manner. It should be noted that, in accordance with the most preferred embodiment of the invention, the mounted and soldered components 34, 36, and 38 are preferably "potted" after they have been so mounted, by applying a small quantity (*e.g.*, a drop or two) of silicone adhesive or the like around at least their edges, to settle around and cover at least side portions of each such component and in particular its soldered or otherwise connected electrical terminals, to thereby further protect them

from undesired direct contact with external objects, and seal them from moisture, dirt, etc. This final potting step will or may cover the entire memory chip 38 (as seen at 64 in Fig. 6), as well as the perimeter of the "window" openings left in the shielding and insulating layers 40, 42, and 44, mentioned above, which are provided for the purpose of mounting the electro-optical components. As shown in Fig. 8, the adhesive layer 13 may have somewhat smaller apertures for the components 34, 36, and 38 than the shielding layer 14 and body 12, such that the edges of the adhesive (which may be a thin film) overlie the ends of terminals 48 connected to the traces 32 on the substrate 26 (or overlie the potting compound 64).

It should be pointed out that the calibration chip 38 preferably comprises a miniaturized digital read-only memory device that is programmed at the factory in accordance with the overall performance parameters of the particular optodes used on a given substrate, *i.e.*, the detection response of the particular detectors involved in relation to the particular light emissions produced by the particular emitters (LEDs) being used, regardless of whatever the actual output wavelength of the latter may be (actual center wavelengths of LEDs and the like being subject to a certain amount of variance even though generally within a specified band, and affecting the wavelength-related measurement performance during spectrophotometric procedures). In this manner, the actual performance characteristics of each individual sensor may be instantly and automatically "read" from the sensor by the spectrophotometric device upon being connected thereto, and appropriate calibration of the device for that particular sensor being automatically implemented by the device using its own internal computer or controller.

The completely assembled flex circuit 26, as described above, is placed atop the foam main body 12, with the shielding layer 14 and adhesive layer 13 disposed therebetween, and with the electro-optical components in direct registry with, and disposed within, the corresponding apertures 56 provided in body 12, at which time the memory chip 38 and covered (potted) terminals 48 are preferably received into their corresponding recesses 58 in the foam body 12. This surface configuration of the foam body 12 is illustrated in Fig. 5, in which the openings for the overmolded electro-optical assemblies are designated by the numeral 56 and the recesses for the terminals 48 (as potted, or otherwise) are designated by the numeral 58. As further illustrated in Fig. 5, the top of the main body 12 preferably has a generally flat longitudinal plateau-like

section 60 having the same basic shape as the adhesive layer 13, shielding layer 14 and flex circuit 26, for receiving the latter in flush relationship, and the side portions 62 of main body 12 outboard of plateau area 60 (Figs. 3 and 5) preferably taper downwardly toward the edges of the body, whose flat underside carries the adhesive layer 18a that
5 contacts the skin of the patient/test subject, together with the removable protective outer liner layer 18b.

The narrowed waist portion 24 of main body 12, and the adjacent smaller and larger rounded end portions 20, 22 are provided at least in part in order to reduce the overall size (footprint) of the sensor while nonetheless ensuring optimal shielding of both
10 light and electromagnetic effects for the emitter 34 and detectors 36 and their associated circuitry. In this regard, it should be noted that the conductive body 12 and even the conductive adhesive layer 18a comprise part of the electromagnetic shielding for the sensor, along with the various conductive layers noted above, all of which should be interconnected and coupled to a system ground or other such circuit point (preferably, in
15 accordance with the commonly owned prior patents identified above and incorporated by reference). At the same time, the illustrated sensor configuration also enhances the conformability of sensor 10 to various patient/test subject surface configurations without wrinkling or otherwise distorting the surface of the sensor in the area directly adjacent the patient/test subject, which is an important factor. Of course, the size and shape of
20 the sensor must also be sufficient to ensure reliable adhesion to the forehead of the patient, but this obviously also involves the relative adhesiveness of the substance used in the adhesive layer 18a. Notwithstanding these utilitarian considerations, the "figure 8" or "snowman" shape, as generally illustrated, is also very distinctive and esthetic in appearance, and also helps to differentiate this sensor from all others.

It should be pointed out that there are significant advantages in terminating the electrical conductors for the electro-optical components (*i.e.*, the flex circuit 26 in the preferred embodiment described above) at a point closely adjacent the sensor 10 itself, and using a disconnectable connector at that point to couple the sensor to the
25 spectrophotometric instrument, rather than equipping the sensor with a relatively long length electrical cable or the like whose end extremity carries a plug that is connectable to the instrument itself or some other point intermediate the two. By so doing, the cost of the sensor-connected cable may be eliminated from the cost of each sensor, and perhaps even more importantly the incentive to use inexpensive and hence inefficient
30

cable for this purpose is eliminated. At the same time, the use of high-grade and relatively expensive cable permanently connected to the oximeter instrument is actually made attractive since it need only be provided once, performs better, and is usable a great many times. In addition, the sensor itself is made lighter in weight and less susceptible to motion artifact, *etc.*, and, the automated and hence less expensive manufacture of the sensor is facilitated, since the practice of using lengthy connection cable attached permanently to the sensor required a manual soldering operation at the point of attachment. At the same time, use of a flex circuit such as that described above not only facilitates automated sensor manufacture but also eliminates other hand wiring, soldering, *etc.* No doubt, other significant advantages will be perceived by those skilled in the art upon further consideration of the foregoing specification.

It should be understood that the foregoing disclosure and attached drawings are directed to one or more particular preferred embodiments of the invention for purposes of illustration, and that variations and modifications of such particular embodiments may well occur to those skilled in the art after considering this disclosure. All such variations *etc.*, should therefore be considered an integral part of the underlying invention, especially in regard to particular shapes, configurations, component choices and variations in structural and system features.

The invention claimed is:

1. A compact, lightweight and flexible spectrophotometric sensor for clinical applications comprising:

5 a flexible body which is compliantly conformable to the shape of a subject to be examined;

a thin and flexible substrate mounted on said body, said substrate having electrically conductive traces on at least portions of a surface;

10 a plurality of electro-optical components mounted on said substrate and electrically coupled to said conductive traces, said components including at least one light source and at least one light detector;

15 said light source and said light detector components each having at least one side and an integrally attached generally opaque member having a generally annular collar-like portion on at least said side thereof to provide a light-guiding passage to and from said side, said generally opaque members and their respective electro-optical components each comprising an integral assembly adapted to facilitate robotic handling and precise placement thereof upon said substrate.

20 2. A spectrophotometric sensor as set forth in claim 1, wherein said light source and light detector components further include an optically clear light-transmissive covering on at least said side thereof.

3. A spectrophotometric sensor as set forth in claim 2, wherein said collar-like portion is disposed over said light-transmissive covering.

25 4. A spectrophotometric sensor as set forth in claim 1, wherein said collar-like portion comprises an overmolded structure which is molded in place on said electro-optical components.

30 5. A spectrophotometric sensor as set forth in claim 4, wherein said light source and light detector components further include an optically clear light-transmissive covering on at least said side thereof.

6. A spectrophotometric sensor as set forth in claim 5, wherein said collar-like portion is disposed over said light-transmissive covering.
7. A spectrophotometric sensor as set forth in claim 1, further including at least one shielding layer disposed between said substrate and said body.
8. A spectrophotometric sensor as set forth in claim 7, wherein said at least one shielding layer comprises a metal-carrying fabric.
9. A spectrophotometric sensor as set forth in claim 8, wherein said at least one layer comprises a metal-impregnated fabric.
10. A spectrophotometric sensor as set forth in claim 2, wherein said light-transmissive covering substantially encapsulates its related component.
11. A spectrophotometric sensor as set forth in claim 4, wherein said over-molded structure substantially encapsulates the component on which it is formed.
12. A spectrophotometric sensor as set forth in claim 11, wherein said overmolded structure is disposed over the light-transmissive covering on the associated component.
13. A spectrophotometric sensor as set forth in claim 1, wherein said body has a thickness greater than that of said integral assembly comprising an electro-optical component and its associated generally opaque member, and wherein said body has a recess for receiving each of said integral assemblies.
14. A spectrophotometric sensor as set forth in claim 13, wherein said body recesses comprise passages extending through said body and opening outwardly thereof through each of two opposite sides, whereby said integral assemblies are receivable into said passages from a first of said sides and face toward the passage opening on the other of said sides, to send or receive light therethrough.

15. A spectrophotometric sensor as set forth in claim 14, further including at least one shielding layer disposed between said substrate and said body, said shielding layer having an aperture therethrough positioned to register with said body recesses and sized to receive and pass said integral assemblies therethrough.

5

16. A spectrophotometric sensor as set forth in claim 15, wherein said electrically conductive traces are located on a side surface of said substrate and said side is disposed adjacent said body and said shielding layer is disposed between said side surface and a surface of said body.

10

17. A compact, lightweight and flexible spectrophotometric sensor for clinical applications comprising:

a flexible body which is compliantly conformable to the shape of a subject to be examined;

15

a thin and flexible substrate mounted on said body, said substrate having electrically conductive traces on at least portions of a surface;

a plurality of electro-optical components mounted on said substrate and electrically coupled to said conductive traces, said components including at least one light source and at least one light detector;

20

said substrate and said electrically conductive traces extending outwardly of said body only a short distance and terminating at an electrical connector;

said connector having a plurality of separate electrical terminals and certain of said traces being electrically coupled to certain of said terminals;

25

whereby said electro-optical components on said substrate are electrically connectable to a clinical device located at a distance from the sensor by means of a reusable intermediate cable connected to said clinical device and single use of said sensor results in minimal economic loss.

30

18. A spectrophotometric sensor as set forth in claim 17, wherein said short distance comprises only a few inches.

19. A compact, lightweight and flexible spectrophotometric sensor for clinical applications comprising:

a flexible body which is compliantly conformable to the shape of a subject to be examined;

a thin and flexible substrate mounted on said body, said substrate having electrically conductive traces on at least portions of a surface;

5 a plurality of electro-optical components mounted on said substrate and electrically coupled to said conductive traces, said components including at least one light source and at least one light detector;

10 said body having an overall shape which is thin when viewed from the side or end and which is rounded on the ends and narrows into a necked-down region between said ends when viewed in plan, said substrate extending across said necked-down region and into each of a first and second area located on opposite sides of said region, said at least one light source being disposed at said first area of said body located on one side of said necked-down region and said at least one light detector being disposed at said second area of said body located on the other side of said necked-down region.

15 20. A spectrophotometric sensor as set forth in claim 19, wherein both said first and said second areas of said body are rounded over most of their surface when viewed in plan.

20 21. A spectrophotometric sensor as set forth in claim 21, wherein each of said rounded ends of said body are substantially wider than said substrate.

22. A compact, lightweight and flexible spectrophotometric sensor for clinical applications comprising:

25 a flexible body which is compliantly conformable to the shape of a subject to be examined;

a thin and flexible substrate mounted on said body, said substrate having electrically conductive traces on at least portions of a surface;

30 a plurality of electro-optical components mounted on said substrate and electrically coupled to said conductive traces, said components including at least one light source and at least one light detector;

a data memory chip mounted on said substrate and having electrical terminals connected to said conductive traces thereon, to store and read out data representative of

the overall intensity response of the particular light detector mounted on said substrate to light from the particular light source mounted thereon, thereby facilitating calibration of a clinical analytic device coupled to said sensor for operation therewith.

5 23. A spectrophotometric sensor as set forth in claim 22, wherein said memory chip has a protective covering over its exterior.

24. A spectrophotometric sensor as set forth in claim 23, wherein said protective covering extends over the electrical terminals of said memory chip.

10

25. A spectrophotometric sensor as set forth in claim 24, wherein said memory chip comprises a miniature digital read-only memory.

15

26. A spectrophotometric sensor as set forth in claim 1, further including a data memory chip mounted on said substrate and having electrical terminals connected to said conductive traces thereon, to store and read out data representative of the overall intensity response of the particular light detector mounted on said substrate to light from the particular light source mounted thereon, thereby facilitating calibration of a clinical analytic device coupled to said sensor for operation therewith.

20

27. An electro-optical component assembly for use in a spectrophotometric sensor, comprising in combination:

an electrically actuated and optically responsive component to emit or receive light when electrically connected; and

25

an encasement covering at least the edges and part of an optically responsive side of said component, said encasement defining a light-transmissive path for light impinging upon or emitted from said optically responsive side of said component, and said encasement being formed in place upon said component.

30

28. An electro-optical component assembly for use in a spectrophotometric sensor as set forth in claim 27, wherein said encasement defines an aperture disposed in alignment with said optically responsive side of said component, said aperture forming at least part of said light transmissive path.

29. An electro-optical component assembly for use in a spectrophotometric sensor as set forth in claim 27, wherein said encasement comprises optically transmissive material which covers at least said edges and said side of said component, said optically
5 transmissive material comprising at least part of said light transmissive path.

30. An electro-optical component assembly for use in a spectrophotometric sensor as set forth in claim 29, wherein said encasement further includes an outer covering extending over the outside of at least portions of said optically transmissive material,
10 said outer cover being generally opaque and defining an aperture disposed in alignment with said optically responsive side of said component, and with said optically transmissive path, said aperture forming an extension of said path.

31. An electro-optical component assembly for use in a spectrophotometric sensor as set forth in claim 30, wherein said outer covering comprising an overmolding which is
15 formed in place upon said component and optically transmissive covering.

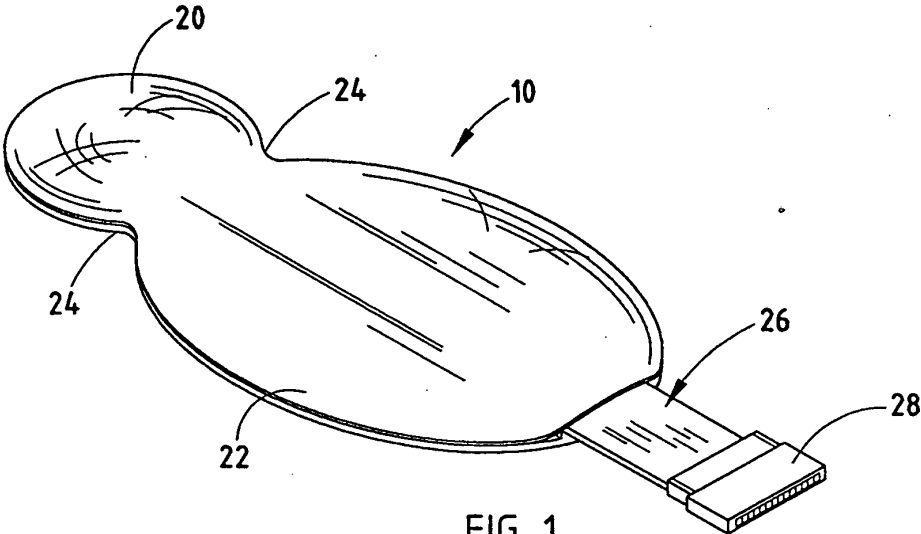

FIG. 1

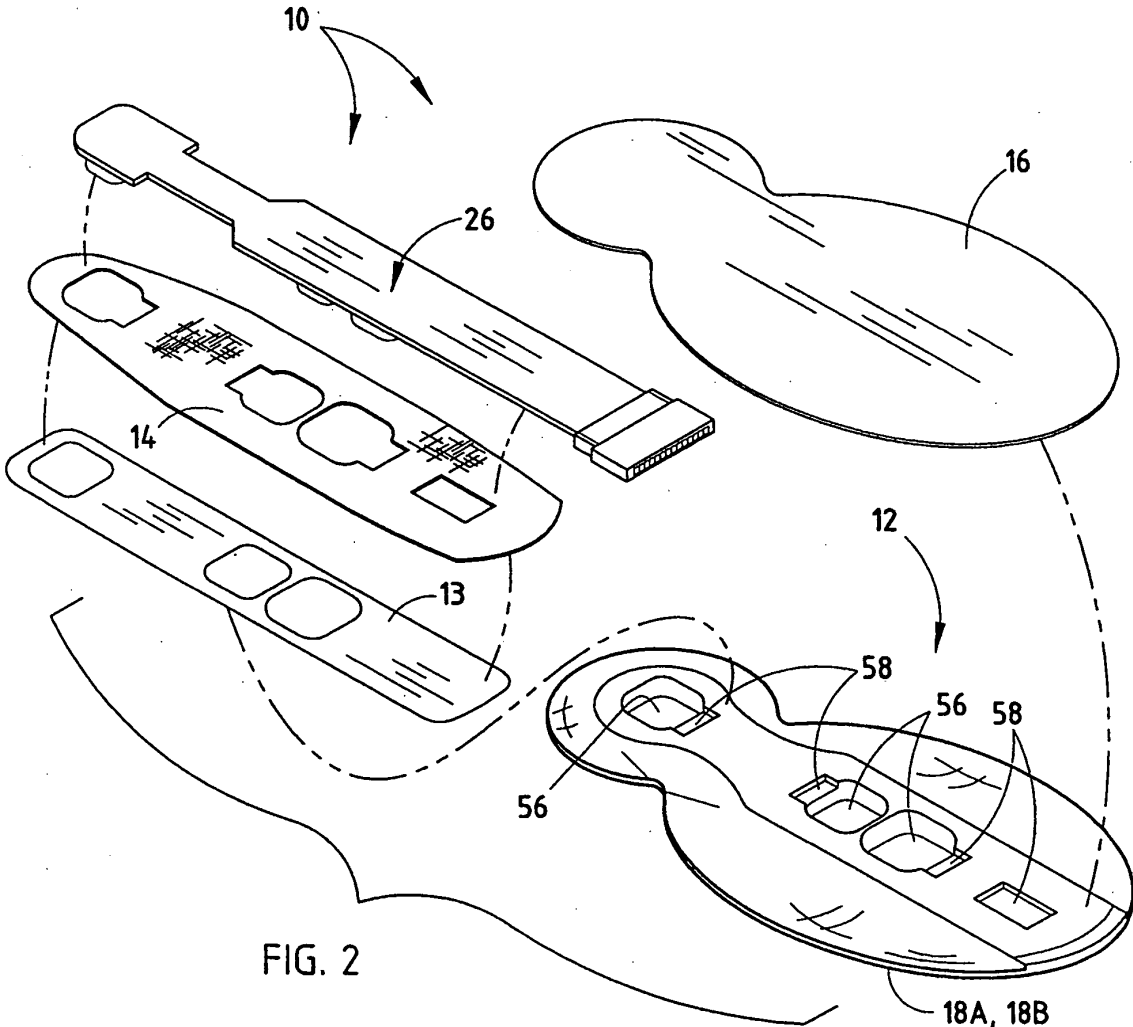

FIG. 2

2/3

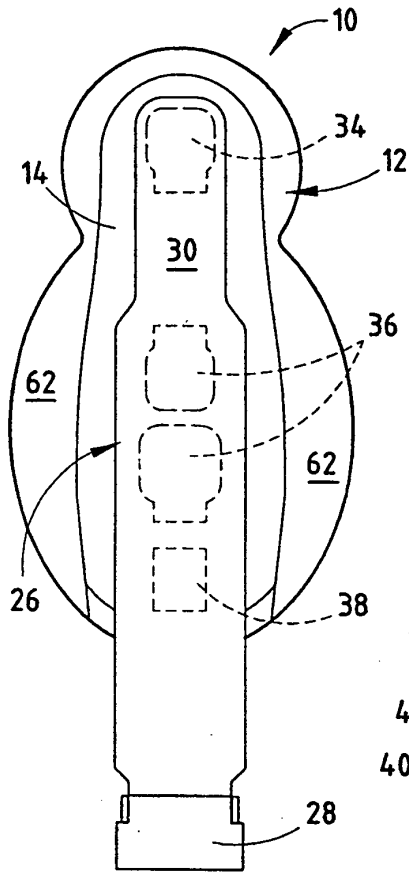

FIG. 3

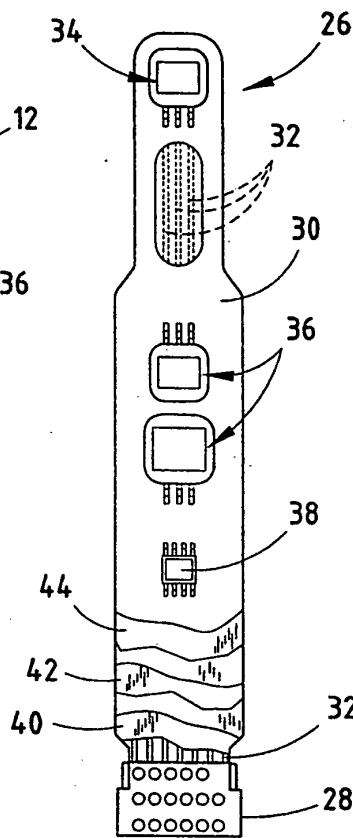

FIG. 4

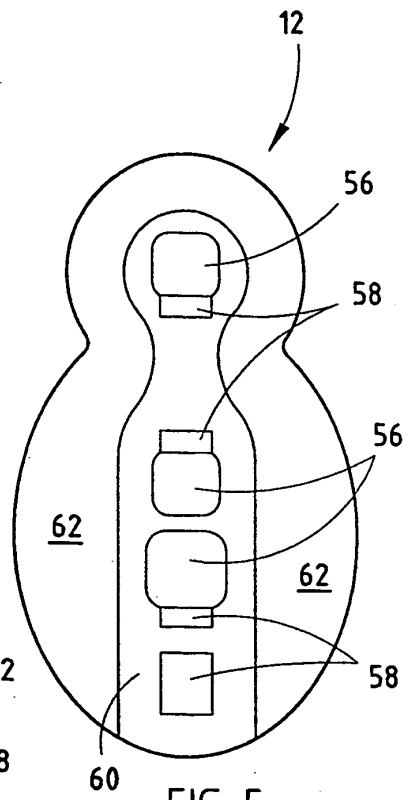

FIG. 5

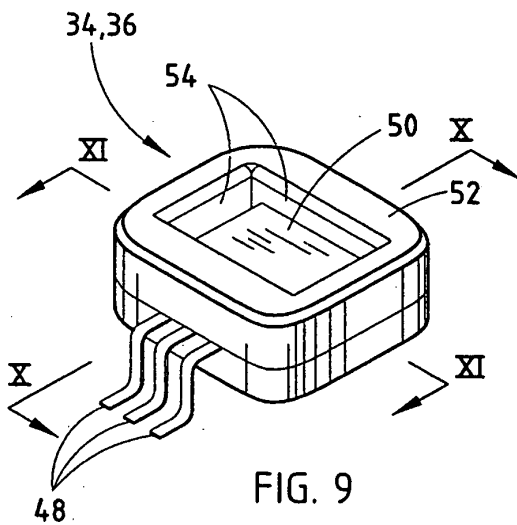

FIG. 9

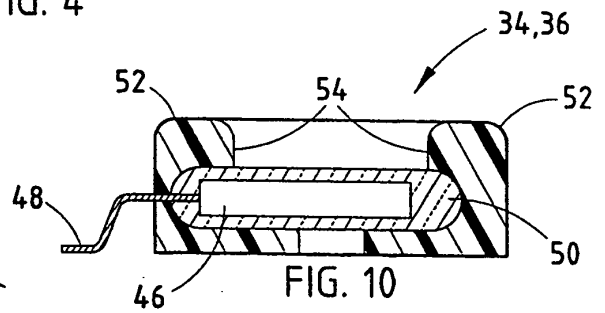

FIG. 10

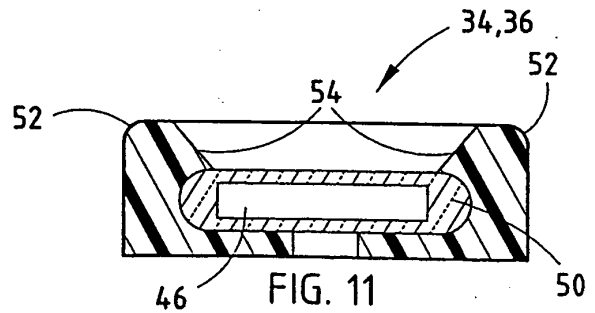

FIG. 11

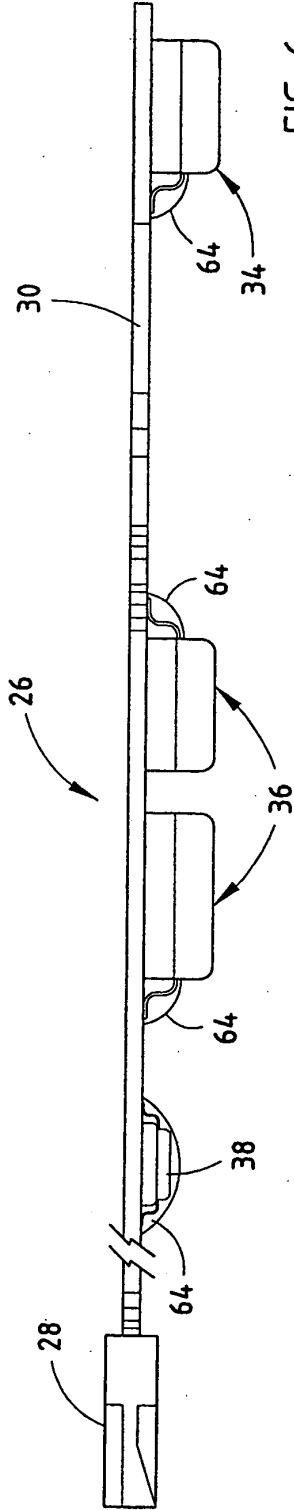

FIG. 6

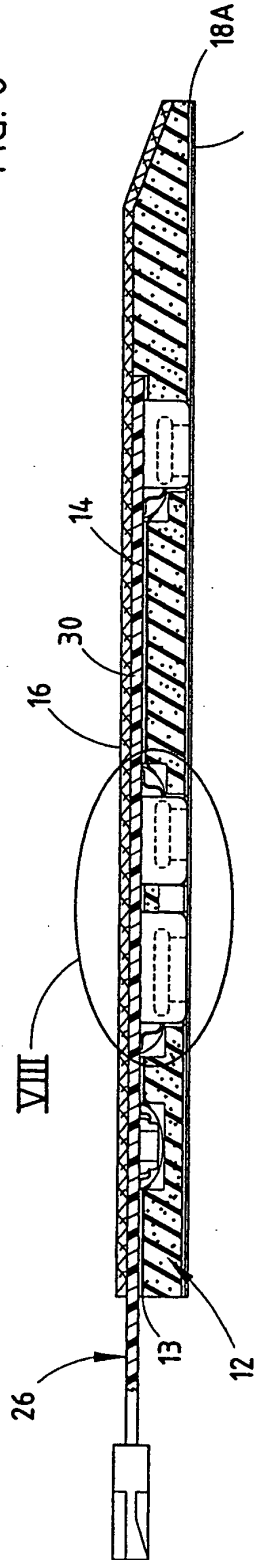

FIG. 7

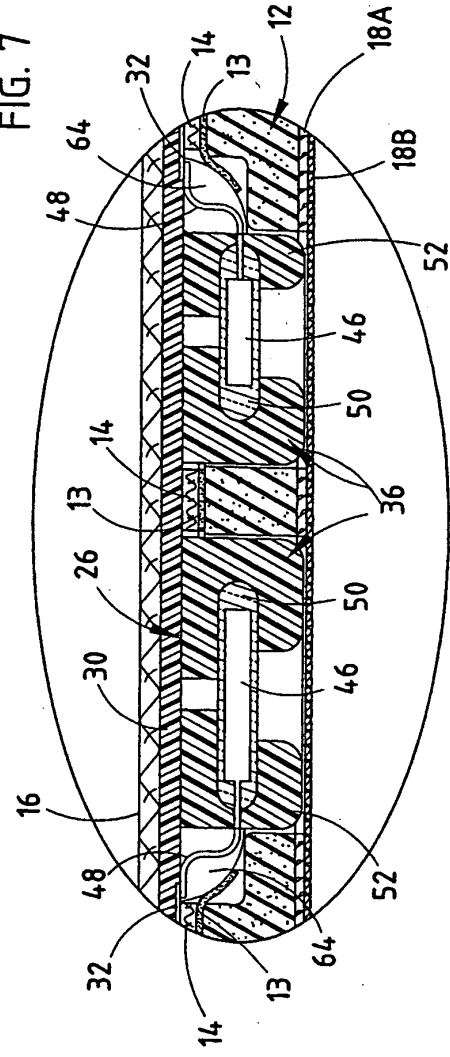
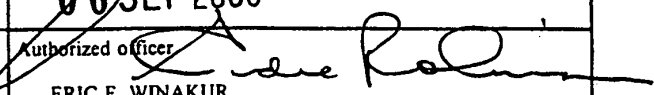

FIG. 8

INTERNATIONAL SEARCH REPORT

International application No.
PCT/US00/09502

A. CLASSIFICATION OF SUBJECT MATTER IPC(7) : A61B 5/00 US CL : 600/323, 344 According to International Patent Classification (IPC) or to both national classification and IPC				
B. FIELDS SEARCHED Minimum documentation searched (classification system followed by classification symbols) U.S. : 600/310, 322, 323, 340, 344 Documentation searched other than minimum documentation to the extent that such documents are included in the fields searched Electronic data base consulted during the international search (name of data base and, where practicable, search terms used)				
C. DOCUMENTS CONSIDERED TO BE RELEVANT				
Category*	Citation of document, with indication, where appropriate, of the relevant passages	Relevant to claim No.		
X — Y	US 5,584,296 A (CUI et al.) 17 December 1996, col. 8 line 43 to col. 10 line 61.	1-12 ----- 26		
X — Y	US 5,249,576 A (GOLDBERGER et al.) 05 October 1993, entire document.	17-25 ----- 26		
X	US 5,465,714 A (SCHEUING) 14 November 1995, col. 5 line 56 to col. 6 line 34.	27, 29		
<input type="checkbox"/> Further documents are listed in the continuation of Box C. <input type="checkbox"/> See patent family annex.				
<table style="width: 100%; border: none;"> <tr> <td style="width: 50%; border: none;"> * Special categories of cited documents: "A" document defining the general state of the art which is not considered to be of particular relevance "E" earlier document published on or after the international filing date "L" document which may throw doubts on priority claim(s) or which is cited to establish the publication date of another citation or other special reason (as specified) "O" document referring to an oral disclosure, use, exhibition or other means "P" document published prior to the international filing date but later than the priority date claimed </td> <td style="width: 50%; border: none;"> "T" later document published after the international filing date or priority date and not in conflict with the application but cited to understand the principle or theory underlying the invention "X" document of particular relevance; the claimed invention cannot be considered novel or cannot be considered to involve an inventive step when the document is taken alone "Y" document of particular relevance; the claimed invention cannot be considered to involve an inventive step when the document is combined with one or more other such documents, such combination being obvious to a person skilled in the art "&" document member of the same patent family </td> </tr> </table>			* Special categories of cited documents: "A" document defining the general state of the art which is not considered to be of particular relevance "E" earlier document published on or after the international filing date "L" document which may throw doubts on priority claim(s) or which is cited to establish the publication date of another citation or other special reason (as specified) "O" document referring to an oral disclosure, use, exhibition or other means "P" document published prior to the international filing date but later than the priority date claimed	"T" later document published after the international filing date or priority date and not in conflict with the application but cited to understand the principle or theory underlying the invention "X" document of particular relevance; the claimed invention cannot be considered novel or cannot be considered to involve an inventive step when the document is taken alone "Y" document of particular relevance; the claimed invention cannot be considered to involve an inventive step when the document is combined with one or more other such documents, such combination being obvious to a person skilled in the art "&" document member of the same patent family
* Special categories of cited documents: "A" document defining the general state of the art which is not considered to be of particular relevance "E" earlier document published on or after the international filing date "L" document which may throw doubts on priority claim(s) or which is cited to establish the publication date of another citation or other special reason (as specified) "O" document referring to an oral disclosure, use, exhibition or other means "P" document published prior to the international filing date but later than the priority date claimed	"T" later document published after the international filing date or priority date and not in conflict with the application but cited to understand the principle or theory underlying the invention "X" document of particular relevance; the claimed invention cannot be considered novel or cannot be considered to involve an inventive step when the document is taken alone "Y" document of particular relevance; the claimed invention cannot be considered to involve an inventive step when the document is combined with one or more other such documents, such combination being obvious to a person skilled in the art "&" document member of the same patent family			
Date of the actual completion of the international search 10 AUGUST 2000	Date of mailing of the international search report 06 SEP 2000			
Name and mailing address of the ISA/US Commissioner of Patents and Trademarks Box PCT Washington, D.C. 20231 Facsimile No. (703) 305-3230	Authorized officer:  ERIC F. WINAKUR Telephone No. (703) 308-3940			



INTERNATIONAL APPLICATION PUBLISHED UNDER THE PATENT COOPERATION TREATY (PCT)

<p>(51) International Patent Classification⁶ : G01N 21/27, 21/31</p>	<p>A1</p>	<p>(11) International Publication Number: WO 98/43071 (43) International Publication Date: 1 October 1998 (01.10.98)</p>
<p>(21) International Application Number: PCT/IB97/00292 (22) International Filing Date: 21 March 1997 (21.03.97) (71) Applicant: NELLCOR PURITAN BENNETT INC. [US/US]; 4280 Hacienda Drive, Pleasanton, CA 94588 (US). (72) Inventors: BAKER, Clark, R., Jr.; 18493 Magee Way, Castro Valley, CA 94546 (US). YORKEY, Thomas, J.; 3072 Bernard Avenue, San Ramon, CA 94583 (US).</p>	<p>(81) Designated States: AU, CA, JP, European patent (AT, BE, CH, DE, DK, ES, FI, FR, GB, GR, IE, IT, LU, MC, NL, PT, SE). Published <i>With international search report.</i></p>	
<p>(54) Title: METHOD AND APPARATUS FOR ARBITRATING TO OBTAIN BEST ESTIMATES FOR BLOOD CONSTITUENT VALUES AND REJECTING HARMONICS</p>		
<p>(57) Abstract</p> <p>A method of measuring a blood constituent value using data comprising a single data set comprises: (a) determining a plurality of possible blood constituent values using a plurality of blood constituent value calculators, each of the blood constituent value calculators using the single data set, each of the possible blood constituent values having a confidence level associated therewith based on at least one quality metric; and (b) arbitrating between the plurality of possible blood constituent values with regard to the confidence levels to determine a measure of the blood constituent.</p>		

FOR THE PURPOSES OF INFORMATION ONLY

Codes used to identify States party to the PCT on the front pages of pamphlets publishing international applications under the PCT.

AL	Albania	ES	Spain	LS	Lesotho	SI	Slovenia
AM	Armenia	FI	Finland	LT	Lithuania	SK	Slovakia
AT	Austria	FR	France	LU	Luxembourg	SN	Senegal
AU	Australia	GA	Gabon	LV	Latvia	SZ	Swaziland
AZ	Azerbaijan	GB	United Kingdom	MC	Monaco	TD	Chad
BA	Bosnia and Herzegovina	GE	Georgia	MD	Republic of Moldova	TG	Togo
BB	Barbados	GH	Ghana	MG	Madagascar	TJ	Tajikistan
BE	Belgium	GN	Guinea	MK	The former Yugoslav Republic of Macedonia	TM	Turkmenistan
BF	Burkina Faso	GR	Greece			TR	Turkey
BG	Bulgaria	HU	Hungary	ML	Mali	TT	Trinidad and Tobago
BJ	Benin	IE	Ireland	MN	Mongolia	UA	Ukraine
BR	Brazil	IL	Israel	MR	Mauritania	UG	Uganda
BY	Belarus	IS	Iceland	MW	Malawi	US	United States of America
CA	Canada	IT	Italy	MX	Mexico	UZ	Uzbekistan
CF	Central African Republic	JP	Japan	NE	Niger	VN	Viet Nam
CG	Congo	KE	Kenya	NL	Netherlands	YU	Yugoslavia
CH	Switzerland	KG	Kyrgyzstan	NO	Norway	ZW	Zimbabwe
CI	Côte d'Ivoire	KP	Democratic People's Republic of Korea	NZ	New Zealand		
CM	Cameroon			PL	Poland		
CN	China	KR	Republic of Korea	PT	Portugal		
CU	Cuba	KZ	Kazakstan	RO	Romania		
CZ	Czech Republic	LC	Saint Lucia	RU	Russian Federation		
DE	Germany	LI	Liechtenstein	SD	Sudan		
DK	Denmark	LK	Sri Lanka	SE	Sweden		
EE	Estonia	LR	Liberia	SG	Singapore		

-1-

METHOD AND APPARATUS FOR ARBITRATING TO OBTAIN BEST ESTIMATES
FOR BLOOD CONSTITUENT VALUES & REJECTING HARMONICS

This invention relates to a method and apparatus for measuring physiological parameters, in particular for processing data so that its reliability can be assessed. It relates in particular to a method and apparatus for arbitrating to obtain best estimates for blood constituent values and rejecting harmonics.

Pulse oximeters typically measure and display various blood flow characteristics including the oxygen saturation of haemoglobin in arterial blood and pulse rate. Oximeters pass light through blood perfused tissue such as a finger or an ear, and photoelectrically sense the absorption of light in the tissue. The amount of light absorbed is then used to calculate the amount of the blood constituent (for example oxyhaemoglobin) being measured.

Techniques for calculating blood oxygen saturation levels in haemoglobin are disclosed in International patent application no. IB96/ filed with the present application entitled METHOD AND APPARATUS FOR ADAPTIVELY AVERAGING DATA SIGNALS, which bears the reference P21977A. Information concerning these features of the present invention that is disclosed in those documents is incorporated in the specification of the present application by this reference. The disclosed technique involves assigning varying weights to different measurements, the weighted measurements being averaged to obtain a filtered measurement. It employs Kalman filtering techniques to calculate blood oxygen saturation. Kalman filtering allows one to fit parameters in a least squares sense when the parameters are varying in time.

Other techniques for calculating blood oxygen saturation levels in haemoglobin, in which a harmonic filter is used to reduce noise effects, are disclosed in International patent application no. IB96/ filed with the present application entitled METHOD AND APPARATUS FOR HARMONICALLY FILTERING DATA,

-2-

entitled METHOD AND APPARATUS FOR HARMONICALLY FILTERING DATA, which bears the reference P21977D. Information concerning these features of the present invention that is disclosed in that document is incorporated in the specification of the present application by this reference.

Techniques for determining pulse rates are disclosed in International patent application no. IB96/ filed with the present application entitled METHOD AND APPARATUS FOR MEASURING PULSE RATE AND SATURATION, which bears the reference P21977B. Information concerning these features of the present invention that is disclosed in this document is incorporated in the specification of the present application by this reference. A technique disclosed in the document involves use of a comb filter to isolate signal energy which corresponds to fundamental and related frequencies.

The present invention provides a technique for assessing signals relating to physiological parameters, in particular blood oxygen saturation and pulse rate, to determine whether and how they are to be displayed. The signals can be derived using techniques of the type that are disclosed in the specifications of the three applications referred to above. The technique of the invention involves arbitrating between possible values of the parameter in question according to a confidence level associated with each value based in a quality metric.

Accordingly, in one aspect, the invention provides a method of measuring a blood constituent value (for example, oxygenated haemoglobin in blood) using data comprising a single data set, which comprises:

- (a) determining a plurality of possible blood constituent values using a plurality of blood constituent value calculators, each of the blood constituent value calculators using the single data set, each of the

-3-

possible blood constituent values having a confidence level associated therewith based on at least one quality metric; and

(b) arbitrating between the plurality of possible blood constituent values with regard to the confidence levels to determine a measure of the blood constituent.

In another aspect, the invention provides apparatus for measuring a blood constituent using a single data set, by applying the method referred to above.

In a further aspect, the invention provides a method of determining a patient's pulse rate using data comprising a single data set corresponding to electromagnetic energy transmitted through the tissue of a patient, the method comprising the steps of:

(a) determining a plurality of possible pulse rates using a plurality of pulse rate estimators, each of the pulse rate estimators using the single data set, each of the possible pulse rates having a confidence level associated therewith based on at least one quality metric; and

(b) arbitrating between the plurality of possible pulse rates with regard to the confidence levels to determine the patient's pulse rate.

In yet another aspect, the invention provides apparatus for determining a patient's pulse rate using a single data set, by applying the method referred to above.

Preferably, the arbitrating step comprises:

(a) comparing the confidence levels for each of the values with the confidence levels for other values; and

-4-

(b) selecting as the measure of the blood constituent or of the pulse rate (as the case may be) one of the plurality of possible values having a confidence level greater than all other confidence levels by at least a first amount.

Preferably, the arbitrating step comprises linearly interpolating between the plurality of possible values to generate the measure of the blood constituent or the patient's pulse rate (as the case may be) where none of the confidence levels is greater than all other confidence levels by more than a first amount.

When the method is measuring a blood constituent value, it is preferred that the quality metric is selected from the group comprising age of the possible blood constituent value and variance of the possible blood constituent value.

Preferably, in the second method aspect of the invention, the pulse rate estimator determines its corresponding possible pulse rate by:

- (a) defining a comb filter to remove signal energy from the data corresponding to a fundamental frequency and harmonics thereof;
- (b) determining a particular harmonic frequency which minimizes noise energy at an output of the comb filter, the particular harmonic frequency corresponding to the fundamental frequency; and
- (c) generating the possible pulse rate corresponding to the particular harmonic frequency.

Preferably, the step of determining the harmonic frequency comprises:

- (a) calculating squared noise for the data;

-5-

- (b) calculating a second derivative of the squared noise with respect to the fundamental frequency; and
- (c) performing a Newton-Raphson search to determine the particular harmonic frequency.

The determination of the pulse rate by the pulse rate estimator can include the steps of:

- (a) evaluating a power spectrum corresponding to the data to determine which of a plurality of peaks in the power spectrum corresponds to the fundamental frequency; and
- (b) verifying that the particular harmonic frequency corresponds to the fundamental frequency based on the evaluating step.

When the method is determining a patient's pulse rate, it is preferred that the quality metric is selected from the group comprising pulse signal shape, signal-to-noise ratio, correlation of the at least one wavelength of electromagnetic energy, arrhythmia probability, and, when there are two wavelengths of electromagnetic energy, a correlation between the data corresponding to the two wavelengths.

The pulse rate estimator in the second method aspect of the invention can determine its corresponding possible pulse rate by:

- (a) comparing the data to a predetermined waveform template;
- (b) identifying a sequence of waveform characteristics indicative of a waveform period;
- (c) averaging a number of successive waveform periods to determine an average waveform period; and
- (d) determining the corresponding possible pulse rate from the average waveform period.

-6-

The method can include a step of identifying pulse data that is corrupted by motion, and rejecting that data.

The quality metric can then be selected from the group comprising a motion indication, and a proportion of motion corrupted pulse periods detected over a time interval.

In a yet further aspect, the invention provides a method of determining a pulse rate of a patient using data corresponding to at least one wavelength of electromagnetic energy transmitted through tissue of the patient, which comprises:

- (a) tracking a fundamental frequency using an adaptive comb filter to filter the data and to thereby generate a first pulse rate, the first pulse rate having a first confidence level associated therewith based on at least one quality metric;
- (b) comparing the data to a predetermined waveform template to generate a second pulse rate, the second pulse rate having a second confidence level associated therewith based on the at least one quality metric; and
- (c) arbitrating between the first and second pulse rates with regard to the first and second confidence levels to determine the patient's pulse rate.

Preferably, the tracking step comprises:

- (a) defining a comb filter to remove signal energy from the data corresponding to the fundamental frequency and harmonics thereof; and
- (b) determining a particular harmonic frequency which minimizes noise energy at an output of the comb filter, the particular harmonic frequency corresponding to the fundamental frequency.

-7-

Preferably, the step of determining the harmonic frequency then comprises:

- (a) calculating squared noise for the data;
- (b) calculating a second derivative of the squared noise with respect to the fundamental frequency; and
- (c) performing a Newton-Raphson search to determine the fundamental frequency.

The tracking step can comprise:

- (a) evaluating a power spectrum corresponding to the data to determine which of a plurality of peaks in the power spectrum corresponds to the fundamental frequency; and
- (b) verifying that the particular harmonic frequency corresponds to the fundamental frequency based on the evaluating step.

It might also include a step of filtering the first pulse rate to determine a filtered first pulse rate, for example by a filtering technique such as Kalman filtering.

Preferably, the comparing step of the method comprises:

- (a) identifying a sequence of waveform characteristics indicative of a waveform period;
- (b) averaging a number of successive waveform periods to determine an average waveform period; and
- (c) determining the second pulse rate from the average waveform period.

Preferably, the arbitrating step of the method comprises:

- (a) comparing the first and second confidence levels; and

-8-

- (b) selecting as the patient's pulse rate one of the first and second confidence levels which is greater than the other of the first and second confidence levels by at least a first amount.

The arbitrating step can comprise linearly interpolating between the first and second pulse rates to generate the patient's pulse rate where neither of the first and second confidence levels is greater than the other of the first and second confidence levels by more than a first amount.

Preferably, the at least one quality metric corresponding to the first confidence level is selected from the group comprising pulse signal shape, signal-to-noise ratio, correlation of the at least one wavelength of electromagnetic energy, and arrhythmia probability.

Preferably, there are two wavelengths of electromagnetic energy, and the at least one quality metric corresponding to the first confidence level comprises a correlation between the data corresponding to the two wavelengths.

Preferably, the at least one quality metric corresponding to the second confidence level is selected from the group comprising a motion indication, and a proportion of motion corrupted pulse periods detected over a time interval.

Preferably, prior to the processing step, the method includes the steps of:

- (a) taking the logarithm of a signal representative of the at least one wavelength of electromagnetic energy, thereby generating a first signal;
- (b) band pass filtering the first signal, thereby generating a second signal; and
- (c) normalizing the second signal, thereby generating the data;

-9-

the tracking step comprising taking the derivative of the data.

The invention can involve reduction of noise effects when measuring a physiological parameter. It can include apparatus for reducing the noise effects which comprises:

means for generating a plurality of measurements derived from at least one wavelength of electromagnetic energy transmitted through living tissue;

means for providing a signal indicative of the at least one wavelength of electromagnetic energy;

means for comparing selected measurements with at least one expected measurement characteristic;

means for assigning one of a plurality of variable weights to each selected measurement based on the comparing step thereby generating a plurality of differently weighted measurements for each wavelength, the variable weights being assigned, in part, in response to a similarity between each selected measurement and a corresponding previous measurement, the variable weights comprising a plurality of different non-zero numbers;

means for averaging a plurality of the differently weighted measurements to obtain a filtered measurement for use in estimating the physiological parameter; and

means for calibrating the system to measure the physiological parameter in response to the signal indicative of the at least one wavelength of electromagnetic energy.

The invention also includes a monitor for measuring a physiological parameter, the monitor being for use with a sensor having emitting means for emitting at least one wavelength of electromagnetic energy, sensing means for sensing the electromagnetic energy and for generating a first signal representative thereof, means for detachably coupling the sensor to the oximeter and for providing communication of signals between the sensor and the oximeter, and means for providing a second signal indicative of the at least one wavelength of electromagnetic energy, the monitor comprising:

-10-

means for generating a plurality of measurements derived from the first signal;

means for comparing selected measurements with at least one expected measurement characteristic;

means for assigning one of a plurality of variable weights to each selected measurement based on the comparing step thereby generating a plurality of differently weighted measurements, the variable weights being assigned, in part, in response to a similarity between each selected measurement and a corresponding previous measurement, the variable weights comprising a plurality of different non-zero numbers;

means for averaging a plurality of the differently weighted measurements to obtain a filtered measurement for use in estimating the physiological parameter; and

means for calibrating the monitor to measure the physiological parameter in response to the second signal.

There now follows a discussion of preferred methods of processing and displaying the blood oxygen saturation and pulse rate for use on a hospital floor. With metrics that are available from algorithms for measuring oxygen saturation levels and pulse rates, confidence levels for the saturation and the pulse rate values that are calculated can be estimated, thus determining which saturation and which pulse rate of the multiple pulse rates and multiple saturations can be considered reliable, and how long the saturation or pulse rate previously selected should be held when a current estimate is not considered sufficiently reliable.

The present invention can be applied to blood oxygen saturation values calculated using Kalman filtering techniques (with or without cardiac gated averaging) as disclosed in the International patent application no. IB96/ (P21977A) referred to above. Metrics that can be calculated from these algorithms include:

Age: effective averaging period is double this; and

-11-

Deviation: standard deviation of saturation estimate in saturation points.

The present invention can be applied to pulse rate values calculated using a comb filter as disclosed in the International patent application no. [] referred to above. Metrics that can be calculated from these algorithms include:

Validity: a heuristic metric based on the strength of harmonics in the pulse, i.e., the shape of the pulse;

S/N: signal-to-noise ratio;

Arrhythmia probability: a function of S/N vs. Uncorrelation averaged over time; and

Uncorrelation (IR & red) $\sqrt{1 - \text{crosscorrelation}(IR, red)^2}$
where crosscorrelation is over an appropriate number of sample points.

Motion flag: set when motion is detected; and

Motion Percent: percentage of motion corrupted patterns detected in the last ten seconds.

The confidence interval for a pulse rate measured using an adaptive comb filter is a function of the validity metric and the arrhythmia probability metric. This space divides into several regions in which one or both metrics are the determining factor in how likely the adaptive comb filter is to be tracking the correct rate.

The Age and Deviation metrics can be used to determine saturation. A general algorithm for calculating the age of the output of an IIR filter having the form

$$\text{Filtered}(n+1) = (1 + W) * \text{Filtered}(n) - W * \text{Raw},$$

-12-

where the age of Filtered and Raw are known, and Filtered(n) is the value at sample number n, is described by the following steps:

- 1) Increment the age of Filtered by the amount of time elapsed since it was last calculated; and
- 2) Age of Filtered(n + 1) = (1 + W) * Age of Filtered(n) + W * Age of Raw

Preferably, the technique of the invention involves evaluation of several properties of the incoming oximetry signal, independent of the confidence metrics for the parameter in question (for example oxygen saturation and pulse rate) to determine whether the signal is actually due to a human pulse and what should appear on the display that is provided. Possible states include:

- | | |
|----------------|--|
| Disconnect: | when the sensor is unplugged; |
| No Contact: | when the sensor does not make sufficient contact with the patient; |
| Pulse lost: | when the pulse disappears and the sensor is still on the patient; |
| Non-pulse: | when the oximetry signal comes from a signal other than a human pulse because the sensor has fallen off or is seeing an enormous amount of interference; |
| Pulse Present: | when the oximetry signal comes from a human pulse; and |
| Not Sure: | a waiting period before declaring a Disconnect or Non-pulse state. |

The possible actions in response to the occurrence of these various states are to update the display, hold the current values, or clear the display, for example blanks, dashes, zeroes, etc.

The criteria for the various states are evaluated in the following order:

-13-

Pulse lost: The % IR modulation is below a threshold for period of seconds, or the criteria for Non-pulse are met and the previous state had been Pulse lost.

Non-pulse: The uncorrelation is high and the percentage of energy above 5 Hz is high, OR the percent IR modulation is low. This criterion has been true for ten seconds continuously. If this criterion has been true for less than ten seconds, the Not Sure state is declared.

Pulse present: The state is not one of the above states.

The criteria for the various display actions are UPDATE when the state is Pulse present, HOLD when the state is Not Sure or No contact, and CLEAR when the state is Disconnect, Pulse lost, or Non-pulse.

The best saturation is displayed when 1) the signal state action is UPDATE, and 2) the best saturation is sufficiently recent. Saturation is held when 1) the conditions for displaying the best saturation are not met, 2) the displayed saturation is less than sufficiently recent, and 3) the signal state action is not CLEAR. Saturation is blanked when 1) the conditions for displaying the best saturation are not met, and 2) the conditions for holding the saturation are not met.

The best heart rate is displayed when 1) the best calculated heart rate has a high confidence, and 2) the signal state action is UPDATE. The heart rate is held when 1) the conditions for displaying the current heart rate are not met, 2) the displayed heart rate is sufficiently recent, and 3) the signal state action is not CLEAR. The heart rate is blanked when 1) the conditions for displaying the current heart rate are not met, and 2) the conditions for holding the heart rate are not met.

-14-

CLAIMS:

1. A method of measuring a blood constituent value using data comprising a single data set, which comprises:

(a) determining a plurality of possible blood constituent values using a plurality of blood constituent value calculators, each of the blood constituent value calculators using the single data set, each of the possible blood constituent values having a confidence level associated therewith based on at least one quality metric; and

(b) arbitrating between the plurality of possible blood constituent values with regard to the confidence levels to determine a measure of the blood constituent.

2. A method as claimed in claim 1, in which the arbitrating step comprises:

(a) comparing the confidence levels for each of the possible blood constituent values with the confidence levels for other blood constituent values; and

(b) selecting as the measure of the blood constituent one of the plurality of possible blood constituent values having a confidence level greater than all other confidence levels by at least a first amount.

3. A method as claimed in claim 1, in which the arbitrating step comprises linearly interpolating between the plurality of possible blood constituent values to generate the measure of the blood constituent where none of the confidence levels is greater than all other confidence levels by more than a first amount.

-15-

4. A method as claimed in claim 1, in which the at least one quality metric is selected from the group comprising age of the possible blood constituent value and variance of the possible blood constituent value.

5. A method as claimed in claim 1, in which the blood constituent comprises oxygenated haemoglobin in arterial blood.

6. Apparatus for measuring a blood constituent using a single data set, comprising:

(a) means for determining a plurality of possible blood constituent values using a plurality of blood constituent value calculators, each of the blood constituent value calculators using the single data set, each of the possible blood constituent values having a confidence level associated therewith based on at least one quality metric; and

(b) means for arbitrating between the plurality of possible blood constituent values with regard to the confidence levels to determine a measure of the blood constituent.

7. A method of determining a patient's pulse rate using data comprising a single data set corresponding to energy transmitted through the tissue of a patient, the method comprising the steps of:

(a) determining a plurality of possible pulse rates using a plurality of pulse rate estimators, each of the pulse rate estimators using the single data set, each of the possible pulse rates having a confidence level associated therewith based on at least one quality metric; and

-16-

(b) arbitrating between the plurality of possible pulse rates with regard to the confidence levels to determine the patient's pulse rate.

8. A method as claimed in claim 7, in which the arbitrating step comprises:

(a) comparing the confidence levels for each of the possible pulse rates with the confidence levels for other possible pulse rates; and

(b) selecting as the patient's pulse rate one of the plurality of possible pulse rates having a confidence level greater than all other confidence levels by at least a first amount.

9. A method as claimed in claim 7, in which the arbitrating step comprises linearly interpolating between the plurality of possible pulse rates to generate the patient's pulse rate where none of the confidence levels is greater than all other confidence levels by more than a first amount.

10. A method as claimed in claim 7, in which one pulse rate estimator determines its corresponding possible pulse rate by:

(a) defining a comb filter to remove signal energy from the data corresponding to a fundamental frequency and harmonics thereof;

(b) determining a particular harmonic frequency which minimizes noise energy at an output of the comb filter, the particular harmonic frequency corresponding to the fundamental frequency; and

(c) generating the possible pulse rate corresponding to the particular harmonic frequency.

-17-

11. A method as claimed in claim 10, in which the determining step comprises:

- (a) calculating squared noise for the data;
- (b) calculating a second derivative of the squared noise with respect to the fundamental frequency; and
- (c) performing a Newton-Raphson search to determine the particular harmonic frequency.

12. A method as claimed in claim 10 further comprising the steps of:

- (a) evaluating a power spectrum corresponding to the data to determine which of a plurality of peaks in the power spectrum corresponds to the fundamental frequency; and
- (b) verifying that the particular harmonic frequency corresponds to the fundamental frequency based on the evaluating step.

13. A method as claimed in claim 10, in which the at least one quality metric is selected from the group comprising pulse signal shape, signal-to-noise ratio, correlation of the at least one wavelength of electromagnetic energy, and arrhythmia probability.

14. A method as claimed in claim 10, in which there are two wavelengths of electromagnetic energy, and the at least one quality metric comprises a correlation between the data corresponding to the two wavelengths.

15. A method as claimed in claim 7, in which one pulse rate estimator determines its corresponding possible pulse rate by:

-18-

- (a) comparing the data to a predetermined waveform template;
 - (b) identifying a sequence of waveform characteristics indicative of a waveform period;
 - (c) averaging a number of successive waveform periods to determine an average waveform period; and
 - (d) determining the corresponding possible pulse rate from the average waveform period.
16. A method as claimed in claim 15, in which the at least one quality metric is selected from the group comprising a motion indication, and a proportion of motion corrupted pulse periods detected over a time interval.
17. A method of determining a pulse rate of a patient using data corresponding to at least one wavelength of electromagnetic energy transmitted through tissue of the patient, which comprises:
- (a) tracking a fundamental frequency using an adaptive comb filter to filter the data and to thereby generate a first pulse rate, the first pulse rate having a first confidence level associated therewith based on at least one quality metric;
 - (b) comparing the data to a predetermined waveform template to generate a second pulse rate, the second pulse rate having a second confidence level associated therewith based on the at least one quality metric; and
 - (c) arbitrating between the first and second pulse rates with regard to the first and second confidence levels to determine the patient's pulse rate.

-19-

18. A method as claimed in claim 17, in which the tracking step comprises:

(a) defining a comb filter to remove signal energy from the data corresponding to the fundamental frequency and harmonics thereof; and

(b) determining a particular harmonic frequency which minimizes noise energy at an output of the comb filter, the particular harmonic frequency corresponding to the fundamental frequency.

19. A method as claimed in claim 18, in which the determining step comprises:

(a) calculating squared noise for the data;

(b) calculating a second derivative of the squared noise with respect to the fundamental frequency; and

(c) performing a Newton-Raphson search to determine the fundamental frequency.

20. A method as claimed in claim 18, in which the tracking step comprises:

(a) evaluating a power spectrum corresponding to the data to determine which of a plurality of peaks in the power spectrum corresponds to the fundamental frequency; and

(b) verifying that the particular harmonic frequency corresponds to the fundamental frequency based on the evaluating step.

-20-

21. A method as claimed in claim 17, in which the tracking step comprises Kalman filtering the first pulse rate to determine a filtered first pulse rate.

22. A method as claimed in claim 17, in which the comparing step comprises:

(a) identifying a sequence of waveform characteristics indicative of a waveform period;

(b) averaging a number of successive waveform periods to determine an average waveform period; and

(c) determining the second pulse rate from the average waveform period.

23. A method as claimed in claim 17, in which the arbitrating step comprises:

(a) comparing the first and second confidence levels; and

(b) selecting as the patient's pulse rate one of the first and second confidence levels which is greater than the other of the first and second confidence levels by at least a first amount.

24. A method as claimed in claim 17, in which the arbitrating step comprises linearly interpolating between the first and second pulse rates to generate the patient's pulse rate where neither of the first and second confidence levels is greater than the other of the first and second confidence levels by more than a first amount.

25. A method as claimed in claim 17, in which the at least one quality metric corresponding to the first confidence level is selected from the group comprising pulse signal shape,

-21-

signal-to-noise ratio, correlation of the at least one wavelength of electromagnetic energy, and arrhythmia probability.

26. A method as claimed in claim 17, in which there are two wavelengths of electromagnetic energy, and the at least one quality metric corresponding to the first confidence level comprises a correlation between the data corresponding to the two wavelengths.

27. A method as claimed in claim 17, in which the at least one quality metric corresponding to the second confidence level is selected from the group comprising a motion indication, and a proportion of motion corrupted pulse periods detected over a time interval.

28. A method as claimed in claim 17, which includes, before the processing step, the steps of:

(a) taking the logarithm of a signal representative of the at least one wavelength of electromagnetic energy, thereby generating a first signal;

(b) band pass filtering the first signal, thereby generating a second signal; and

(c) normalizing the second signal, thereby generating the data;

and in which the tracking step comprises taking the derivative of the data.

INTERNATIONAL SEARCH REPORT

International Application No

PCT/IB 97/00292

A. CLASSIFICATION OF SUBJECT MATTER
 IPC 6 G01N21/27 G01N21/31

According to International Patent Classification (IPC) or to both national classification and IPC

B. FIELDS SEARCHED

Minimum documentation searched (classification system followed by classification symbols)
 IPC 6 G01N A61B

Documentation searched other than minimum documentation to the extent that such documents are included in the fields searched

Electronic data base consulted during the international search (name of data base and, where practical, search terms used)

C. DOCUMENTS CONSIDERED TO BE RELEVANT

Category *	Citation of document, with indication, where appropriate, of the relevant passages	Relevant to claim No.
X	US 5 355 880 A (THOMAS ET AL.) 18 October 1994	1,7
A	see the whole document	17
A	EP 0 522 674 A (UNIVERSITY OF NEW MEXICO & SANDIA NATIONAL LABORATORIES) 13 January 1993 see the whole document	1-28
A	WO 96 30742 A (CIBA CORNING DIAGNOSTICS CORP.) 3 October 1996 see the whole document	1-28
A	US 5 435 309 A (THOMAS ET AL.) 25 July 1995 see the whole document	1-28
	-/--	

Further documents are listed in the continuation of box C.

Patent family members are listed in annex.

* Special categories of cited documents :

- "A" document defining the general state of the art which is not considered to be of particular relevance
- "E" earlier document but published on or after the international filing date
- "L" document which may throw doubts on priority claim(s) or which is cited to establish the publication date of another citation or other special reason (as specified)
- "O" document referring to an oral disclosure, use, exhibition or other means
- "P" document published prior to the international filing date but later than the priority date claimed

- "T" later document published after the international filing date or priority date and not in conflict with the application but cited to understand the principle or theory underlying the invention
- "X" document of particular relevance; the claimed invention cannot be considered novel or cannot be considered to involve an inventive step when the document is taken alone
- "Y" document of particular relevance; the claimed invention cannot be considered to involve an inventive step when the document is combined with one or more other such documents, such combination being obvious to a person skilled in the art.
- "&" document member of the same patent family

Date of the actual completion of the international search

25 November 1997

Date of mailing of the international search report

08/12/1997

Name and mailing address of the ISA
 European Patent Office, P.B. 5818 Patentlaan 2
 NL - 2280 HV Rijswijk
 Tel. (+31-70) 340-2040. Tx. 31 651 epo nl.
 Fax: (+31-70) 340-3016

Authorized officer

Bosma, R

INTERNATIONAL SEARCH REPORT

International Application No
PCT/IB 97/00292

C.(Continuation) DOCUMENTS CONSIDERED TO BE RELEVANT		
Category *	Citation of document, with indication, where appropriate, of the relevant passages	Relevant to claim No.
A	WO 95 34806 A (LIESENHOFF, TIM ET AL.) 21 December 1995 see the whole document -----	1-6
A	DE 43 39 067 A (JENOPTIK GMBH) 18 May 1995 see the whole document -----	1-6

1

INTERNATIONAL SEARCH REPORT

Information on patent family members

International Application No

PCT/IB 97/00292

Patent document cited in search report	Publication date	Patent family member(s)	Publication date
US 5355880 A	18-10-94	CA 2099400 A EP 0586025 A JP 6178767 A US 5630413 A	07-01-94 09-03-94 28-06-94 20-05-97
EP 522674 A	13-01-93	JP 5261088 A US 5494032 A	12-10-93 27-02-96
WO 9630742 A	03-10-96	AU 4889096 A	16-10-96
US 5435309 A	25-07-95	NONE	
WO 9534806 A	21-12-95	DE 4420401 A AU 2881195 A	21-12-95 05-01-96
DE 4339067 A	18-05-95	WO 9513739 A EP 0679064 A	26-05-95 02-11-95

(12) INTERNATIONAL APPLICATION PUBLISHED UNDER THE PATENT COOPERATION TREATY (PCT)

(19) World Intellectual Property Organization
International Bureau



(43) International Publication Date
21 August 2003 (21.08.2003)

PCT

(10) International Publication Number
WO 03/068060 A1

- (51) International Patent Classification⁷: A61B 5/00
- (21) International Application Number: PCT/FI03/00089
- (22) International Filing Date: 4 February 2003 (04.02.2003)
- (25) Filing Language: English
- (26) Publication Language: English
- (30) Priority Data:
10/077,196 15 February 2002 (15.02.2002) US
- (71) Applicant (for all designated States except US): DATEX-OHMEDA, INC. [US/US]; 3030 Ohmeda Drive, Madison, WI 53707 (US).
- (81) Designated States (national): AE, AG, AL, AM, AT, AU, AZ, BA, BB, BG, BR, BY, BZ, CA, CH, CN, CO, CR, CU, CZ, DE, DK, DM, DZ, EC, EE, ES, FI, GB, GD, GE, GH, GM, HR, HU, ID, IL, IN, IS, JP, KE, KG, KP, KR, KZ, LC, LK, LR, LS, LT, LU, LV, MA, MD, MG, MK, MN, MW, MX, MZ, NO, NZ, OM, PH, PL, PT, RO, RU, SC, SD, SE, SG, SK, SL, TJ, TM, TN, TR, TT, TZ, UA, UG, US, UZ, VC, VN, YU, ZA, ZM, ZW.
- (84) Designated States (regional): ARIPO patent (GH, GM, KE, LS, MW, MZ, SD, SL, SZ, TZ, UG, ZM, ZW), Eurasian patent (AM, AZ, BY, KG, KZ, MD, RU, TJ, TM), European patent (AT, BE, BG, CH, CY, CZ, DE, DK, EE, ES, FI, FR, GB, GR, HU, IE, IT, LU, MC, NL, PT, SE, SI, SK, TR), OAPI patent (BF, BJ, CF, CG, CI, CM, GA, GN, GQ, GW, ML, MR, NE, SN, TD, TG).

- (72) Inventor; and
- (75) Inventor/Applicant (for US only): HUIKU, Matti [FI/FI]; Kaksoiskiventie 30 H, FIN-02760 Espoo (FI).
- (74) Agent: PATENT AGENCY COMPATENT LTD.; Hämeentie 29, 4th Floor, FIN-00500 Helsinki (FI).

Published:
— with international search report

For two-letter codes and other abbreviations, refer to the "Guidance Notes on Codes and Abbreviations" appearing at the beginning of each regular issue of the PCT Gazette.

(54) Title: COMPENSATION OF HUMAN VARIABILITY IN PULSE OXIMETRY

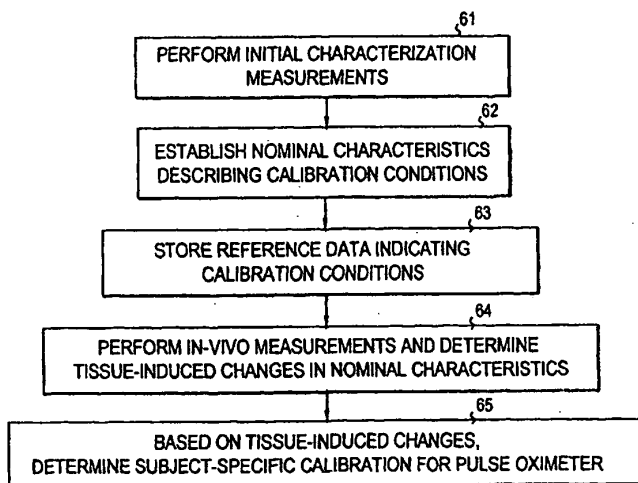

(57) Abstract: The invention relates to the calibration of a pulse oximeter intended for non-invasively determining the amount of at least two light-absorbing substances in the blood of a subject. In order to bring about a solution by means of which the effects caused by the tissue of the subject can be taken into account in connection with the calibration of a pulse oximeter, initial characterization measurements are carried out for a pulse oximeter calibrated under nominal conditions. Based on the characterization measurements, nominal characteristics are established describing the conditions under which nominal calibration has been defined, and reference data indicating the nominal characteristics are stored. In-vivo measurements are then performed on living tissue and based on the in-vivo measurements and the reference data stored, tissue-induced changes in the nominal characteristics are determined. Subject-specific variation in the in-vivo measurements is compensated for by correcting the nominal calibration on the basis of the tissue-induced changes.

WO 03/068060 A1

COMPENSATION OF HUMAN VARIABILITY IN PULSE OXIMETRY

Field of the Invention

The invention relates generally to pulse oximeters used to detect
5 blood oxygenation. More specifically, the invention relates to a method for taking into account human variability in pulse oximeters. The invention further relates to a sensor allowing compensation for the inaccuracies caused by human variability, the sensor being an integral part of the pulse oximeter.

10 Background of the Invention

Pulse oximetry is at present the standard of care for continuous monitoring of arterial oxygen saturation (SpO_2). Pulse oximeters provide instantaneous in-vivo measurements of arterial oxygenation, and thereby an early warning of arterial hypoxemia, for example.

15 A pulse oximeter comprises a computerized measuring unit and a probe attached to the patient, typically to a finger or ear lobe. The probe includes a light source for sending an optical signal through the tissue and a photo detector for receiving the signal after transmission through the tissue. On the basis of the transmitted and received signals, light absorption by the
20 tissue can be determined. During each cardiac cycle, light absorption by the tissue varies cyclically. During the diastolic phase, absorption is caused by venous blood, tissue, bone, and pigments, whereas during the systolic phase there is an increase in absorption, which is caused by the influx of arterial blood into the tissue. Pulse oximeters focus the measurement on this arterial
25 blood portion by determining the difference between the peak absorption during the systolic phase and the constant absorption during the diastolic phase. Pulse oximetry is thus based on the assumption that the pulsatile component of the absorption is due to arterial blood only.

Light transmission through an ideal absorbing sample is determined
30 by the known Lambert-Beer equation as follows:

$$I_{out} = I_{in} e^{-\epsilon DC}, \quad (1)$$

where I_{in} is the light intensity entering the sample, I_{out} is the light intensity received from the sample, D is the path length through the sample, ϵ is the extinction coefficient of the analyte in the sample at a specific
35 wavelength, and C is the concentration of the analyte. When I_{in} , D , and ϵ are known, and I_{out} is measured, the concentration C can be calculated.

In pulse oximetry, in order to distinguish between two species of hemoglobin, oxyhemoglobin (HbO₂), and deoxyhemoglobin (RHb), absorption must be measured at two different wavelengths, i.e. the probe includes two different light emitting diodes (LEDs). The wavelength values widely used are
5 660 nm (red) and 940 nm (infrared), since the said two species of hemoglobin have substantially different absorption values at these wavelengths. Each LED is illuminated in turn at a frequency which is typically several hundred Hz.

The accuracy of a pulse oximeter is affected by several factors. This is discussed briefly in the following.

10 Firstly, the dyshemoglobins which do not participate in oxygen transport, i.e. methemoglobin (MetHb) and carboxyhemoglobin (COHb), absorb light at the wavelengths used in the measurement. Pulse oximeters are set up to measure oxygen saturation on the assumption that the patient's blood composition is the same as that of a healthy, non-smoking individual.
15 Therefore, if these species of hemoglobin are present in higher concentrations than normal, a pulse oximeter may display erroneous data.

Secondly, intravenous dyes used for diagnostic purposes may cause considerable deviation in pulse oximeter readings. However, the effect of these dyes is short-lived since the liver purifies blood efficiently.

20 Thirdly, coatings like nail polish may in practice impair the accuracy of a pulse oximeter, even though the absorption caused by them is constant, not pulsatile, and thus in theory it should not have an effect on the accuracy.

Fourthly, the optical signal may be degraded by both noise and motion artifacts. One source of noise is the ambient light received by the photodetector. Many solutions have been devised with the aim of minimizing or
25 eliminating the effect of the movement of the patient on the signal, and the ability of a pulse oximeter to function correctly in the presence of patient motion depends on the design of the pulse oximeter. One way of canceling out the motion artefact is to use an extra wavelength for this purpose.

30 A further factor affecting the accuracy of a pulse oximeter is the method used to calibrate the pulse oximeter. Usually the calibration is based on extensive empirical studies in which an average calibration curve is determined based on a high number of persons. By means of this calibration curve, which relates the oxygen saturation of blood to pulse oximeter signals,
35 the average difference between the theory and practice (i.e. in-vivo

measurements) is taken into account. The calibration curve typically maps the measured in-vivo signal to a corresponding SpO₂ value.

Pulse oximeters, however, can also utilize the Lambert-Beer model for calculating the concentrations of the different Hb species. In this method of calibration, the measurement signals must first be transformed into signals applicable to the Lambert-Beer model for calculation. This transformation constitutes the calibration of the pulse oximeter, since it is the step which adapts the in-vivo signals to the Lambert-Beer theory, according to which the pulse oximeter is designed to operate. Thus, the calibration curves can also be in the form of transformations used to adapt the actual in-vivo measurements to the Lambert-Beer model.

Transformations are discussed for example in U.S. Patent 6,104,938, which discloses a calibration method based on the absorption properties of each hemoglobin component, i.e. on the extinction coefficients of blood. In this method, the effective extinction coefficients are determined for each light signal via a mathematical transformation from the extinction coefficients according to the Lambert-Beer theory.

However, each patient (i.e. subject of the measurement) has a calibration curve of his or her own, which deviates from the average calibration curve calculated on the basis of a high number of patients. This is due to the fact that for each patient the characteristics of the tissue through which light is transmitted deviate from those of an average patient. One drawback of the current pulse oximeters is that they are incapable of taking this human variability into account. Human variability here refers to any and all factors causing patient-specific variation in the calibration curve, including time-dependent changes in the calibration curve of a single patient. As discussed in the above-mentioned U.S. Patent, subject-dependent variation can also be seen as an effect of a third substance, such as a third hemoglobin species in the blood. However, the variation can also be interpreted as a subject-dependent change in the calibration curve of the pulse oximeter.

Without compensation for human variability, the accuracy of current pulse oximeters is about $\pm 2\%$ SpO₂. However, in multi-wavelength applications in general, and especially if weak absorbers, such as COHb, are to be measured, the human variability represents a much more serious problem. Therefore, techniques of compensation for these inaccuracies are called for.

It is an objective of the invention to bring about a solution by means of which the effects caused by the tissue of the subject can be taken into account when a pulse oximeter is calibrated. In other words, it is an objective of the present invention to create a pulse oximeter which can take into account the differences caused by an individual subject as compared to the average calibration or transformation curve which the current pulse oximeter relies on.

A further objective of the invention is to bring about a general-purpose solution for the compensation of inaccuracies caused by human variability in pulse oximetry, a solution which is not limited to the particular general calibration method employed in the pulse oximeter, but which can be applied to any pulse oximeter regardless of its current built-in calibration method.

Summary of the Invention

These and other objectives of the invention are accomplished in accordance with the principles of the present invention by providing a mechanism by means of which the subject-specific deviation in the tissue-induced effects on the accuracy of the pulse oximeter can be taken into account.

In the method of the invention, the effect of tissue is taken into account and the inaccuracies caused by subject-specific variation in that effect are compensated for. This is implemented by defining a nominal calibration for the apparatus and making off-line measurements, also termed "initial characterization measurements", in order to define the characteristics which describe the conditions under which the nominal calibration has been defined. Reference data indicating the characteristics are stored for subsequent on-line measurements in which light transmission through the actual tissue is measured. (Off-line here refers to measurements performed before the apparatus is taken into use, whereas on-line refers to the actual in-vivo measurements.) Subject-specific calibration is then defined based on the nominal calibration, the on-line measurements, and the reference data created in connection with the off-line measurements. Thus, the inaccuracies are eliminated by means of on-line measurements, which indicate the effect of the tissue. Off-line measurements are used to create the reference data so that light transmission measured subsequently through the tissue of a subject can be used to correct the nominal calibration for that particular subject.

Thus in one aspect the invention provides a method for compensating for subject-specific variability in an apparatus intended for non-invasively determining the amount of at least two light absorbing substances in the blood of a subject and being provided with emitter means for emitting radiation at a minimum of two different wavelengths and with detector means for receiving the radiation emitted, the method comprising the steps of

- 5 - calibrating the apparatus using a nominal calibration,
- carrying out initial characterization measurements, said measurements to include the measuring of radiation received by the detector,
- 10 - based on the characterization measurements, establishing nominal characteristics describing conditions under which the nominal calibration is used,
- storing reference data indicating the nominal characteristics established,
- 15 - performing in-vivo measurements on a living tissue, wherein radiation emitted through the tissue and received by the detector means is measured,
- based on the in-vivo measurements and the reference data stored, determining tissue-induced changes in the nominal characteristics, and
- 20 - compensating for subject-specific variation in the in-vivo measurements by correcting the nominal calibration on the basis of the tissue-induced changes.

In a preferred embodiment of the invention the method is divided in two steps so that the first step compensates for the inaccuracies caused by tissue-induced wavelength shift and the second step compensates for the inaccuracies caused by internal effects occurring in the tissue. The first step is then used to correct the extinction coefficients of the blood analytes to be measured, and the second step is used to correct the average transformation stored in the pulse oximeter.

30 In a further preferred embodiment of the invention the effect of the temperature is also compensated for in connection with the first step.

The method is not limited to pulse oximeters explicitly using the transformations, but can be applied to any pulse oximeter. However, the method is preferably applied to a pulse oximeter based on a transformation, since in a preferred embodiment the method is implemented by carrying out changes separately in the transformation and in the extinction coefficients.

In another aspect, the invention provides an apparatus for non-invasively determining the amount of at least two light absorbing substances in the blood of a subject, the apparatus comprising

- 5 - emitter means for emitting radiation at a minimum of two different wavelengths,
- detector means for receiving said radiation at each of said wavelengths and producing at least two electrical output signals,
- first signal processing means for processing said output signals and producing a modulation signal for each wavelength, whereby each modulation
10 signal represents the pulsating absorption caused by the arterialized blood of the subject,
- second signal processing means for applying a predetermined calibration on said modulation signals, whereby transformed modulation signals applicable in the Lambert-Beer model are obtained,
- 15 - memory means for storing reference data indicating nominal characteristics under which said predetermined calibration has been applied,
- first compensation means, operatively connected to the memory means, for determining tissue-induced changes in the nominal characteristics,
- second compensation means, operatively connected to the first
20 compensation means, for defining a subject-specific calibration by correcting the predetermined calibration on the basis of the tissue-induced changes, and
- calculation means, responsive to the second compensation means, for determining said amounts.

In a still further aspect, the invention provides a sensor for collecting
25 measurement data for a pulse oximeter intended for non-invasively determining the amount of at least two light absorbing substances in the blood of a subject, the sensor comprising

- emitter means for emitting radiation at a minimum of two different
wavelengths,
- 30 - detector means for receiving said radiation at each of said wavelengths and for producing at least two electrical output signals,
- storage means including reference data indicating nominal characteristics describing calibration conditions of the pulse oximeter, said data allowing apparatus connected to the sensor to determine tissue-induced
35 changes in the nominal characteristics when radiation is emitted through said tissue.

Preferred embodiments of the invention are discussed in more detail below.

Brief Description of the Drawings

5 In the following, the invention and its preferred embodiments are described more closely by referring to the examples shown in FIG. 1 to 12 in the appended drawings, wherein:

FIG. 1 illustrates the basic embodiment of a pulse oximeter according to the present invention,

10 FIG. 2 illustrates the signals utilized in the pulse oximeter of FIG. 1,

FIG. 3 shows the extinction coefficients of two different species of hemoglobin as a function of wavelength,

FIG. 4a to 4f illustrate the average transformation curves for two different pulse oximeters,

15 FIG. 5 is a flow diagram illustrating the prior art calibration method,

FIG. 6 is a flow diagram illustrating the general principle according to the present invention,

FIG. 7 is a flow diagram illustrating compensation for the inaccuracies caused by tissue-induced wavelength shift,

20 FIG. 8 illustrates an example of the transmission curve of human tissue, the curve being employed in the compensation of the inaccuracies caused by tissue-induced wavelength shift,

FIG. 9 illustrates the emitter characteristics determined for the compensation,

25 FIG. 10 is a flow diagram illustrating the compensation of the inaccuracies caused by internal effects occurring in the tissue,

FIG. 11 illustrates the low frequency baseline fluctuation utilized in a preferred embodiment of the invention, and

30 FIG. 12 illustrates an embodiment of a sensor according to the invention.

Detailed Description of the Invention

Below, the solution according to the invention is discussed with reference to a pulse oximeter utilizing the above-mentioned transformations and four different wavelengths. As mentioned above, U.S. Patent 6,104,938 discloses a pulse oximeter utilizing the transformations.

FIG. 1 is a block diagram of a pulse oximeter utilizing four different wavelengths. Light from four different LEDs 10a, 10b, 10c, and 10d, each operating at a respective wavelength, passes into patient tissue, such as a finger 11. The light propagated through or reflected from the tissue is received by a photodetector 12, which converts the optical signal received into an electrical signal and feeds it to an input amplifier 13. The amplified signal is then supplied to a control unit 14, which carries out calculation of the amount of the Hb-derivatives in the blood. The control unit further controls the LED drive 15 to alternately activate the LEDs. As mentioned above, each LED is typically illuminated several hundred times per second.

When each LED is illuminated at such a high rate as compared to the pulse rate of the patient, the control unit obtains a high number of samples at each wavelength for each cardiac cycle of the patient. The value of these samples (i.e. the amplitude of the received signal) varies according to the cardiac cycle of the patient, the variation being caused by the arterial blood, as mentioned above. The control unit 14 therefore utilizes four measurement signals, as shown in FIG. 2, each being received at one of the wavelengths.

In order for variations in extrinsic factors, such as the brightness of the LEDs, sensitivity of the detector, or thickness of the finger, to have no effect on the measurement, each signal received is normalized by extracting the AC component oscillating at the cardiac rhythm of the patient, and then dividing the AC component by the DC component of the light transmission or reflection. The signal thus obtained is independent of the above-mentioned extrinsic factors. Thus in this case the control unit utilizes four normalized signals, which are in the following denoted with $dA_i = \frac{AC_i}{DC_i}$, where i is the wavelength in

question (in this basic embodiment of the multi-wavelength pulse oximeter $i=1,2,3, 4$), AC_i is the AC component at wavelength i , and DC_i is the DC component at wavelength i . The signals dA_i are also referred to below as modulation signals. The modulation signals thus indicate how absorption is affected by the arterial blood of the patient.

The above-described measurement arrangement corresponds to a conventional four-wavelength pulse oximeter. The method of the present invention is implemented in the control unit of the pulse oximeter on the basis of the four modulation signals described above, i.e. the novelty of the system resides within the control unit itself. However, to be able to perform the self-

calibration in conjunction with each patient, the control unit requires some pre-calculated data, which is stored in the memory (M1) of the pulse oximeter. Instead of being stored in conjunction with the control unit, this data, or at least part of it, can also be stored in the sensor part of the pulse oximeter. The sensor part, including at least the LEDs and the photo detector, is connected to the signal processing part, which includes the control unit. Consequently, depending on the overall configuration, the novelty can also reside partly in the sensor. The operation of the pulse oximeter is discussed in more detail below.

The theory of pulse oximetry is generally presented as being based on the Lambert-Beer Law. According to this theory, light transmission through the tissue at each wavelength is exponentially dependent on the absorbance of the tissue (Eq. 1). This theory is generally accepted and established as a good model for pulse oximetry.

Next to be discussed is the theory and formalism on which the method of the invention is based.

According to the Lambert-Beer theory and for a system of two analytes, the signals described above can be presented as follows:

$$\begin{aligned}
 dA_1 &= dA \times (\varepsilon_1^{HbO_2} \times HbO_2 + \varepsilon_1^{RHb} \times RHb) \\
 dA_2 &= dA \times (\varepsilon_2^{HbO_2} \times HbO_2 + \varepsilon_2^{RHb} \times RHb) \\
 dA_3 &= dA \times (\varepsilon_3^{HbO_2} \times HbO_2 + \varepsilon_3^{RHb} \times RHb) \\
 dA_4 &= dA \times (\varepsilon_4^{HbO_2} \times HbO_2 + \varepsilon_4^{RHb} \times RHb) \\
 RHb &= 1 - HbO_2
 \end{aligned}$$

where dA is a common factor which depends on the absolute values, i.e. *inter alia* on the total amount of hemoglobin, $\varepsilon_i^{HbO_2}$ is the extinction coefficient of oxyhemoglobin at wavelength i ($i=1-4$), ε_i^{RHb} is the extinction coefficient of deoxyhemoglobin at wavelength i , HbO_2 is the concentration fraction of oxyhemoglobin, and RHb is the concentration fraction of deoxyhemoglobin.

Using a matrix notation, the above dependencies can be expressed for a system of n wavelengths and n analytes as follows:

$$\begin{pmatrix} dA_1 \\ dA_2 \\ \dots \\ dA_n \end{pmatrix} = C * \begin{pmatrix} \varepsilon_{11} \cdot \dots \cdot \varepsilon_{1n} \\ \varepsilon_{21} \cdot \dots \cdot \varepsilon_{2n} \\ \dots \\ \varepsilon_{n1} \cdot \dots \cdot \varepsilon_{nn} \end{pmatrix} \cdot \begin{pmatrix} HbX_1 \\ HbX_2 \\ \dots \\ HbX_n \end{pmatrix} \quad (2),$$

where dA_i is the differential change in absorption (i.e. the modulation signal) at wavelength λ_i , ε_{ij} is the extinction coefficient of the hemoglobin

derivative HbX_j at wavelength λ_i , and the constant C accounts for the change of units to fractional percentages of the concentrations of the analytes HbX_j .

FIG. 3 shows the extinction coefficients (ϵ^{HbO_2} and ϵ^{RHb}) of oxyhemoglobin (HbO_2) and deoxyhemoglobin (RHb) as a function of the wavelength. Point P shown in the figure is the isobestic point of oxyhemoglobin (HbO_2) and deoxyhemoglobin (RHb). The point has the special property that the modulation signal at the wavelength in question does not depend on the respective proportions (relative concentrations) of the hemoglobin species. Thus at the wavelength of point P the effect of the relative concentrations of oxyhemoglobin and deoxyhemoglobin on the result of the measurement is nil. It should be noted, however, that the modulation signal is independent of the relative concentrations only, not of the absolute concentrations. Thus, the absolute amount of the hemoglobin species has an effect on the result of the measurement.

As is known, there is a difference between the Lambert-Beer theory and the practical measurements. The difference is due to the fact that the Lambert-Beer theory does not take into account the scattering and non-homogeneity of the tissue, whereas the actual extinction coefficients are also dependent on the scattering of light caused by the tissue and blood, and on the combined effect of absorption and scattering. The larger the proportion of the attenuation caused by absorption and scattering, the larger is the correction needed between the actual and the theoretical (non-scatter) domains. This correction between these two domains can be represented by the transformation curves discussed above, by means of which the actual in-vivo measurements are mapped to the Lambert-Beer model.

The transformation can be expressed, for example, as follows:

$$N_H^{L-B} = g_H^{-1} (N_H^{in-vivo}) \quad (3),$$

where $N_H = \frac{dA_k}{dA_l}$ is the modulation ratio (the superscript indicating the domain) in the form of a polynomial function (the subscripts k and l indicating the wavelengths in question), and g is the transformation (the subscript "-1" denoting the inverse function).

Figures 4a to 4f illustrate the average transformation curves measured for a pulse oximeter, where the two wavelengths for measuring the two species of hemoglobin are 660 nm and 900 nm and the third wavelength is

either 725 nm or 805 nm. Figures 4a to 4c illustrate the transformation curves for a pulse oximeter with the third wavelength being 725 nm, and Figures 4d to 4f illustrate the transformation curves for a pulse oximeter with the third wavelength being 805 nm. Each curve shows the Lambert-Beer $N_{k,l}$ as a function of the in-vivo $N_{k,l}$ at wavelengths k and l .

FIG. 5 is a flow diagram describing the general measurement principle described in U.S. Patent 6,104,938. In this method, the above-mentioned $N_{k,l}^{in-vivo}$ values are first determined from the dA_l values measured (step 51). The average transformations g_{kl} are then used to convert the measured in-vivo values to values $N_{k,l}^{L-B}$, which can be used in the ideal Lambert-Beer model (step 52). Other input values needed for the Lambert-Beer model are also determined (step 53). In practice these input values are the ideal (nominal) extinction coefficients of the analytes to be measured, the extinction coefficients being given for the center wavelengths used in the measurement. The converted transformation values and the nominal input values (i.e. nominal extinction coefficients) are then used according to the Lambert-Beer model to calculate the concentrations of the desired analytes (step 54). Thus in this approach the in-vivo values $N_{k,l}^{in-vivo}$ measured from the tissue are converted to the ideal in-vitro (cuvette) environment, where the ideal oximetry model (i.e. the Lambert-Beer model) is applied to yield the desired concentrations.

In the standard two wavelength pulse oximetry the prior art technique is to map the modulation ratio $N_{k,l}^{in-vivo}$ directly to the SpO2 percentage measured. In this simple case the transformation is not necessary, though the transformation technique together with the solution in the Lambert-Beer domain can be utilized as well.

There are two basic ways to determine the average transformation, a theoretical approach and an empirical approach. In the empirical approach the measurements are made in the tissue by taking blood samples and measuring the actual proportions of the hemoglobin species and then determining the value of $N_{k,l}^{L-B}$ on the basis of the measured proportions. The transformation is then obtained as the relationship between the values based on the blood samples and the values given by empirical measurements as measured by the pulse oximeter. The theoretical approach, in turn, is based on a known tissue model, which takes into account the characteristics of the tissue as referred to above, which are ignored in the Lambert-Beer model. A first value is

determined for in-vivo N_{kl} by means of the tissue model and a second value on the basis of the Lambert-Beer model. The tissue parameters of the model are determined so that the known 2-wavelength calibration (so-called R-curve) is reproduced. Then using these tissue parameters and the wavelength
5 dependence of the tissue model, the relation of the in-vivo N_{kl} and the Lambert-Beer N_{kl} is extrapolated to other wavelengths in order to obtain the transformations at these new wavelengths. Thus in the theoretical approach no new empirical measurements are made.

In practice the transformation can be a quadratic equation yielding a
10 correction of the order of 20 percent to the measured $N_{kl}^{\text{in-vivo}}$ value, for example. As discussed below, the transformation data (i.e. the transformation curves) are preferably stored in numeric form in the pulse oximeter or the sensor. The number of transformation curves stored in the pulse oximeter can vary, depending on the number of wavelengths used, for example. Typically
15 there is a transformation curve for each wavelength pair.

As mentioned above, the accuracy of a pulse oximeter utilizing an average transformation is not necessarily sufficient, especially if analytes which are weak absorbers are to be measured or if two analytes absorb similarly, whereby it is difficult to distinguish the said analytes from each other.

20 In the present invention the accuracy of the pulse oximeter is improved by taking into account the subject-specific light transmission through the tissue, and changing the values input to the ideal model, i.e. the nominal transformation and the nominal extinction coefficients, on the basis of the measurement to compensate for the subject-specific changes.

25 FIG. 6 is a flow diagram illustrating the general principle of the present invention. In the method of the invention, initial characterization measurements are first made off-line, preferably at the calibration stage of the pulse oximeter with a nominal wavelength pulse oximeter sensor (step 61). Based on the measurements, nominal characteristics are established describing the
30 conditions under which the pulse oximeter has been calibrated (steps 62). As a result of these steps, reference data are stored (step 63), which describe the calibration conditions of the pulse oximeter. In connection with subsequent in-vivo measurements, the same characteristics are again estimated and tissue-induced changes in the characteristics are determined based on the measured
35 characteristics and the reference data stored (step 64). In in-vivo measurement, the $N_{kl}^{\text{in-vivo}}$ values are determined from the dA_l values

measured. On the basis of the changes determined, the subject-specific calibration is then determined (step 65) for the in-vivo measurements to be performed by the pulse oximeter on the subject.

5 It is to be noted here that steps 61-63 are off-line steps performed either when the pulse oximeter has been calibrated in a known manner or at the manufacturing stage of the pulse oximeter sensor when the sensor characteristics are determined. After these steps, the nominal transformation and the nominal extinction coefficients are known to the pulse oximeter.

10 Human tissue can influence the accuracy of a pulse oximeter by two different mechanisms. First a direct wavelength shift is caused in the LED emission due to the filtering effect of the tissue. Namely, on one side of the LED center wavelength the absorption may be larger than on the other, whereby the center wavelength is effectively shifted towards the region with smaller absorption. The second mechanism is a subtle one. It arises from the
15 fact that the arterial blood is in interaction with the surrounding tissue, which can either increase or decrease the effective path length through the arterial blood layer. The first mechanism is in this context termed the external mechanism, since it affects factors external to the tissue (wavelength). The second mechanism is called the internal mechanism, as it is caused by
20 internal factors in the tissue itself.

Therefore, the subject-specific variations in the influence of tissue are preferably compensated for by adding two compensating processes to the above-described prior art mechanism; the first process attends to the subject-specific variation in the external mechanism, and the second one to the
25 subject-specific variation in the internal mechanism. The first process preferably controls the extinction coefficients to be input to the Lambert-Beer model, while the second process preferably controls the value of the transformation used to transform the modulation ratios $N_{kl}^{\text{in-vivo}}$ to the Lambert-Beer model $N_{kl}^{\text{L-B}}$. The linear equations with the unknown analyte
30 concentrations are then solved in the Lambert-Beer model, as in the prior art method. The degree of these compensations is determined by DC light transmission through the tissue (the measured DC signal), measured both in off-line and on-line conditions.

35 The first process is illustrated in the flow diagram of FIG. 7. Initial off-line measurements are again made in order to determine the nominal characteristics under which the pulse oximeter has been calibrated (steps 71

and 72). As a result of these steps, reference data is created and stored, the data indicating the nominal characteristics (step 73). On the basis of the data and the in-vivo measurements made, the tissue-induced changes in the extinction coefficients are then determined in connection with the in-vivo
 5 measurements (step 74). The new coefficients are then used in the Lambert-Beer model to solve the concentrations of the analytes (step 75). Thus in this embodiment the extinction coefficients are changed in a subject-specific manner in order to improve the accuracy of the pulse oximeter.

In one preferred embodiment of the invention the compensation for
 10 any other wavelength shift type interference than tissue-induced interference, such as a shift caused by high LED temperature, spectral absorption, or reflection properties of the sensor cushion or adhesive, is also implemented in connection with compensation for the filtering effect of the tissue.

In the following the compensations are discussed in more detail by
 15 disclosing a practical implementation for both compensation steps. The compensation of subject-variability causing wavelength shift type interference (i.e. external mechanism) is discussed first.

In the Lambert-Beer model (see Eq. 2) the effective extinctions
 20 $\varepsilon_{ij}^{effective}$ for broadband emitters, such as LEDs, can be calculated as follows:

$$\varepsilon_{ij}^{effective} = \frac{1}{W} \int_{\Delta\lambda} \varepsilon_j(\lambda) * LED_i(\lambda(T)) * DET(\lambda) * tissue(\lambda) \partial\lambda \quad (4),$$

where the integration is over the LED emission spectrum $LED_i(\lambda(T))$,
 25 $DET(\lambda)$ represents the spectral sensitivity of the detector, $tissue(\lambda)$ is the spectral transmission of light through the tissue, $\varepsilon_j(\lambda)$ is the spectral extinction of the analyte in question, T is the temperature, and $W = \int LED * DET * tissue * \partial\lambda$ represents a normalization factor.

In a preferred embodiment of the invention, the radiation emitting
 means are Light Emitting Diodes (LED), but lasers emitting at one single
 wavelength are also possible. For lasers the effective extinction values are the
 extinction values at the laser wavelength, which can depend, however, on the
 30 temperature of the emitter component. In the case of a laser, Eq. 4 is thus not
 needed to calculate the effective extinction value. In the preferred embodiment
 of the invention the emitter and detector means are located at the tissue site at
 which the radiation is transmitted through the tissue, but the radiation can also
 be conducted to and from the tissue site in a light conducting fiber or in

equivalent conduction means. In this case Eq. 4 shall also include a term for the spectral transmission of the radiation conductor. A sensor utilizing light conducting fibers can be as shown in FIG. 5 of the above-mentioned U.S. Patent 6,104,938.

5 The extinction coefficients can thus be calculated according to this equation by determining all the above factors, which depend on the actual wavelength values. However, as the task of determining the exact value of Eq. 4 is not possible in connection with a real-time pulse oximeter measurement using only a few discrete wavelength bands, in practice the result of Eq. 4 has
10 to be approximated. The compensation is based on determining nominal extinction coefficients and approximating their wavelength dependence in advance at the factory and using this information in the real measurement situation to approximate the final subject-specific extinction coefficients.

The compensation algorithm will now be presented for a 4-wavelength
15 pulse oximeter according to FIG. 1, having four LEDs at nominal wavelengths of 627nm, 645nm, 670nm, and 870nm. The extinction matrix for RHb (first column), HbO₂, HbCO, and metHb (last column) and for the above four wavelengths (627nm on top) is then nominally in L/(mmol*cm).

$$E_H^0 = \begin{pmatrix} 1.132 & 0.1799 & 0.2734 & 3.575 \\ 0.9182 & 0.1124 & 0.1337 & 2.411 \\ 0.7353 & 0.0885 & 0.0550 & 0.5796 \\ 0.2071 & 0.2772 & 0.010 & 0.5754 \end{pmatrix} \quad (5)$$

20 The above extinction coefficients have been calculated applying Eq. 4 at nominal LED drive temperature without the tissue filtering term $tissue(\lambda)$. It then represents a nominal extinction matrix for a SpO₂ sensor before its attachment on the tissue site. This extinction matrix is then altered on the basis of the measured filtering effect caused by the tissue, when the sensor is
25 attached on the site.

We next introduce a parameter called the Functional Light Transmission (FLT)_i at a wavelength i , since it is used below in order to make all DC_i values (measured at varying LED emission powers at the four discrete wavelengths i) comparable to each other. Using DC values comparable to
30 each other is in practice a prerequisite for unveiling the real effect of the tissue on the measurements and the characteristics of the tissue. In order to obtain the comparable units, the DC light transmission for each LED channel

(wavelength) is first measured at a certain emitter drive current, and the measured DC value is then reduced in the preamplifier to a detector current, which is normalized to an emitter current value of 1 mA. When measured without the tissue in the probe, this result is called the Current Transfer Ratio (CTR) of the probe. CTR characterizes the sensor design and the efficiency of the light transmission from the emitters to the detector. It is usually of the order of a few microAmps (of detector current) per one milliAmp (of LED current). Now the tissue (e.g. a finger) is inserted into the probe and the CTR is again measured. This result is now called the Functional Current Transfer Ratio (FCTR) because it is the CTR measured under conditions of the function of the pulse oximeter, i.e. when the tissue is in place in the probe. The FLT₁ is then calculated for each emitter (wavelength) as follows:

$$FLT(\text{emitter}\#k) = FCTR(1mA - \text{emitter} - \text{current}) / CTR(1mA - \text{emitter} - \text{current}).$$

Next the CTR and the FCTR concepts will be linked to the Lambert-Beer absorption model and to the actual measured intensities in the pulse oximeter. The CTR obviously describes how the external probe design factors, such as the color and geometry of the probe, affect the light transmission to the detector. On the other hand, the FLT can be associated with the true transmission through the tissue in units which are normalized to the emitter efficiency. Therefore, Eq. 1 can be written in a slightly different form, as it is often written in transport theory:

$$I = I_0 \exp(-\alpha * d) = I_0 \exp(-\alpha_{\text{int}} * d) \exp(-\alpha_{\text{ext}} * d') \quad (6),$$

where d is the tissue thickness and α is an effective absorption coefficient. The above equation has been divided into two components. The attenuation factor with α_{int} accounts for all internal absorption effects, such as blood and can be associated to the FLT-value as the FLT equals one when no tissue (no internal attenuation) is in the probe, and the factor with α_{ext} accounts for all external attenuations, such as geometrical factors and multiple surface reflections without light penetration into the tissue, and can be associated with the CTR of the probe. (The term d' denotes the 'phantom' absorption thickness parameter for the external effects.) The term α_{ext} is mainly a SpO₂ probe design issue which does not influence the measurement accuracy as such, and thus it need not to be compensated for by any means. The FLT at wavelength k can now be defined as:

$$FLT_k = \frac{I}{I_0 \exp(-\alpha_{ext} * d')} = \exp(-\alpha_{int} * d) = FCTR_k / CTR_k \quad (7).$$

The FLT thus describes light attenuation caused by the tissue, and it can be related to the DC light transmission in the pulse oximeter.

It is now assumed that the spectral tissue transmission is as presented in FIG. 8, which shows spectral characteristics of tissue in the same units for each wavelength, i.e. FLT as a function of the wavelength, based on an empirical measurement. In a continuous real-time SpO2 measurement, the transmission is known at 4 distinct wavelength values (the FLT values derived from the DC values in the pulse oximeter) marked in the figure. At each wavelength the slope of the tissue transmission curve can be determined or approximated using the four transmission values. The slope then determines the change in the tissue transmission in a band of a predetermined width (100 nm in this example) around the center of the LED band. We denote the slopes between 627 to 645nm and 645 to 670nm by A and B, respectively. This definition of the slopes is expressed as:

$$A = \frac{FLT(\lambda_2) - FLT(\lambda_1)}{(\lambda_2 - \lambda_1) * (FLT(\lambda_1) + FLT(\lambda_2)) / 2} * 100$$

and

$$B = \frac{FLT(\lambda_3) - FLT(\lambda_2)}{(\lambda_3 - \lambda_2) * (FLT(\lambda_2) + FLT(\lambda_3)) / 2} * 100,$$

where $FLT(\lambda_i)$ is the measured FLT value determined at wavelength λ_i . The estimation of these slopes can be improved by calculating the curvature at the center LED (645nm). This curvature (change of the slope/nm) is

$$curv = \frac{B - A}{(\lambda_3 - \lambda_1) / 2}.$$

Finally the expressions are obtained for the slopes s at the three red wavelengths using A and B as parameters:

$$\begin{pmatrix} s_{\lambda_1} \\ s_{\lambda_2} \\ s_{\lambda_3} \\ s_{\lambda_4} \end{pmatrix} = \begin{pmatrix} A - curv * (\lambda_2 - \lambda_1) / 2 \\ (A + B) / 2 \\ B + curv * (\lambda_3 - \lambda_2) / 2 \\ -0.5 \end{pmatrix} \quad (8),$$

where the slope at the IR wavelength has been estimated to be constant as it cannot be determined by the other LEDs. If we had had another LED, at about 800-1000nm range, for example, it could have been used for the estimation of the IR slope. Because the extinction curves are very flat at
 5 870nm and the transmission is usually rather high, the tissue prefilter cannot alter the effective extinction coefficient from its nominal value significantly. The approximation of a constant transmission slope is thus considered sufficient.

In principle these slopes could be inserted in Eq. 4 in order to integrate the new true values for the extinction coefficients. However, this is
 10 impractical to do in real-time, so a simpler algorithm is presented below. We first calculate off-line the relative changes of extinction coefficients for each analyte of the system using Eq. 4 and assuming that the value of the slope equals a predetermined value, which is one in this example. This calculation results in a shift matrix of Eq. 9:

$$15 \quad Tissue_{SHIFT}^{SLOPE=1} = \begin{pmatrix} 0.975 & 0.942 & 0.940 & 0.999 \\ 0.984 & 0.966 & 0.920 & 0.916 \\ 0.963 & 0.986 & 0.896 & 0.789 \\ 1.01 & 1.03 & 0.903 & 1.05 \end{pmatrix} \quad (9),$$

where the effective extinction of HbO₂ at 645nm is 0.966 times the original value, and the effective extinction of HbCO at 670nm is 0.896 times the original value, for example. Thus, the matrix of Eq. 9 defines the relative changes caused by the tissue, assuming that the slope of the tissue
 20 transmission curve equals one. During in-vivo measurement, the slope is estimated using the DC values. The ratio of the slopes then indicates the relative change of a coefficient. In other words, if the relative change determined off-line for a slope value of X1 is r, the relative change for a measured slope value of X2 is then r*(X2/X1). The relative changes are
 25 different for different analytes since the extinction coefficients of the different analytes behave differently as a function of wavelength.

In real-time the effective extinction coefficients can thus be calculated as follows:

$$E^{Eff} = E_H^0 \otimes (1 + S \bullet (Tissue_{SHIFT}^{SLOPE=1} - 1)) \quad (10),$$

30 where S denotes the column array in Eq. 8 and the matrix multiplications are performed element by element (\otimes) or element by row (\bullet), respectively.

If the LEDs are not driven at the nominal drive currents, their effective wavelength may also be shifted by the temperature change at the LED p-n junction. The wavelength shift induced by temperature is typically about 0.1-0.2 nm/°C which is significant if the drive currents are high, as is usually the case at wavelengths shorter than 660 nm. Thus, the extinction matrix of Eq. 10 must also be compensated for in varying LED drive conditions.

There are many ways to find out the temperature of the LED p-n junction. One alternative is to add a temperature sensor on the LED substrate and use the reading of the sensor for the compensation of all LED emission wavelengths. Though the junction temperature follows the substrate temperature according to some empirical heat conduction model, the method may be unreliable because the LED chip contact to the substrate and the internal heat conductivity may vary considerably. A better way is therefore to determine the junction temperature directly from the forward voltage drop of the LED junction. The junction has typical diode characteristics, which can be determined off-line for each LED separately after assembling the LEDs on the substrate. It is even possible to measure, with an optical spectrometer the shift of the emission as a function of the LED forward voltage. Relating the wavelength shift to the forward voltage assumes that the forward voltage is measured during the operation of the pulse oximeter. The circuit board of the pulse oximeter should thus preferably have means for performing the forward voltage measurement. But if it does not, the LED emission shift can be calibrated against the temperature sensor at the substrate. The LED manufacturer specifications for the temperature shift can then be used to calculate the corresponding wavelength shift. Still another practical compensation for the emitter temperature changes is to map empirically the relationship of the emitter drive current to the observed wavelength shift and to use this information to adjust the on-line extinction coefficients for the sensor.

A method for temperature compensation of the LED emission is now presented, assuming that the LED forward voltage is measured on the circuit board. The wavelength shifts can then be calculated as follows

$$\begin{pmatrix} \Delta\lambda_1 \\ \Delta\lambda_2 \\ \Delta\lambda_3 \\ \Delta\lambda_4 \end{pmatrix} = \begin{pmatrix} k_1 \\ k_2 \\ k_3 \\ k_4 \end{pmatrix} \cdot \begin{pmatrix} \Delta V_1 \\ \Delta V_2 \\ \Delta V_3 \\ \Delta V_4 \end{pmatrix} \quad (11),$$

where the shift coefficients k_i are values determined empirically in advance and ΔV_i are the measured changes of the forward voltage drops. For the 627-645-670-870nm LEDs of the sensor, the k-values are 0.06 nm/mV, 0.06nm/mV, 0.09nm/mV, and 0.1nm/mV, respectively.

5 As in the compensation discussed above relating to tissue filtering, it is practical to first calculate the change in the extinction coefficients off-line for a certain fixed wavelength shift. In this example the relative changes of the extinction coefficients are calculated, as in Eq. 9, for a 5 nm wavelength shift for each of the four hemoglobin derivatives. The following shift matrix is then
10 obtained:

$$Temp_{SHIFT}^{\Delta\lambda=5nm} = \begin{pmatrix} 0.919 & 0.820 & 0.798 & 0.974 \\ 0.963 & 0.926 & 0.823 & 0.794 \\ 0.941 & 0.983 & 0.855 & 0.725 \\ 1.0 & 1.01 & 0.963 & 1.02 \end{pmatrix} \quad (12).$$

During in-vivo measurement the relative changes are then calculated based on the measured wavelength shift. The ratio of the wavelength shifts then indicates the relative change of a coefficient caused by temperature. In
15 other words, if the relative change calculated for a wavelength shift of $Y1$ is r , the relative change for the measured (on-line) wavelength shift of $Y2$ is $r \cdot (Y2/Y1)$. The relative changes are different for different analytes, since the extinction coefficients of the different analytes behave differently as a function of wavelength.

20 The temperature compensated extinction coefficients are thus:

$$E_{TEMP}^{EFF} = E_{kl}^0 \otimes (1 + (\Delta\lambda / 5nm) \cdot (Temp_{SHIFT}^{\Delta\lambda=5nm} - 1)) \quad (13),$$

where $\Delta\lambda$ is the array in Eq. 11. As mentioned earlier, $\Delta\lambda$ can also be estimated by reading the temperature indicated by the temperature sensor on the LED substrate or by measuring the LED drive current and using the
25 mapping of the current to the wavelength shift.

The compensation of the variability causing wavelength shift type interference can now be summed up as follows:

$$E^{EFF} = E_{kl}^0 \otimes (1 + S \cdot (Tissue_{SHIFT}^{SLOPE=1} - 1)) \otimes (1 + (\Delta\lambda / 5nm) \cdot (Temp_{SHIFT}^{\Delta\lambda=5nm} - 1)) \quad (14).$$

As mentioned above, the practical compensations can be divided into
30 steps performed off-line prior to the actual measurements, for example in the factory at the manufacturing stage of the pulse oximeter sensor, and to steps

performed on-line, i.e. in connection with the actual in-vivo measurements. Using the above practical example, the off-line compensation steps are as follows.

1. The spectral characteristics of the emitter/detector system is established. In other words, the LEDs are characterized for their light emission (the emission as a function of wavelength) and the detector for its spectral sensitivity. This step thus includes determination of the characteristics of the curve shown in FIG. 9, i.e. the received intensity as a function of wavelength (at least around the wavelengths used). The light transmission from the light emitter to the light detector is measured without human tissue, i.e. the CTR is determined in the sensor in a fixed setup mimicking the actual use of the sensor. For clip-type sensors this is usually the Probe Off position of the sensor. The step also includes determination of the center wavelength of each LED.

2. The effective extinction coefficients are determined without the tissue term. Thus in this step Eq. 4 is used without the tissue term ($tissue(\lambda)$) to form a matrix E_{kl}^0 according to Eq. 5.

3. The relative changes in the effective extinction coefficients due to tissue filter effect are determined. Here Eq. 4 is used assuming that the slope of $tissue(\lambda)$ equals a predetermined fixed value at each wavelength. In other words, the shift matrix of Eq. 9 is determined.

4. The relative changes in the effective extinction coefficients due to wavelength shift caused by changes in temperature are determined. In other words, the matrix of Eq. 12 is determined, which indicates the relative changes for a wavelength shift of a predetermined value.

5. If the LED forward voltage method is used, the LED forward voltages are characterized at a typical drive current for small ambient temperature changes. The temperature coefficients k_l in Eq. 11 and the nominal forward voltage drops at nominal temperature are determined for each LED.

6. The information obtained is saved in a memory unit in the sensor or in the control unit, or the corresponding information is otherwise made available to the pulse oximeter, for example, by using codes, such as sensor identification numbers, which indicate the values of the information.

As is obvious from the above, steps 1 to 6 include performing initial measurements for the compensation, said measurements to include

measuring the light transmission of the apparatus, establishing nominal DC transmission characteristics of the apparatus on the basis of the measurements, and for subsequent in-vivo measurements storing reference data which indicate the transmission characteristics established.

5 Thus in the off-line measurements, the value of Eq. 4 is determined using nominal values, and the nominal extinction matrix is formed. The apparatus is also provided with the data needed in the subsequent on-line compensation steps for calculating the changes in the factors included in Eq. 4. In the on-line steps the said changes are determined and a new extinction
10 matrix is formed, whereby the new extinction values are such that the external effects are compensated for.

To sum up, after the off-line steps the pulse oximeter stores the matrices according to equations 5, 9, and 12 and the values of the shift coefficients k_i . In addition to this, the oximeter stores the CTR values and the
15 center wavelengths corresponding to these values.

Following the above practical algorithm, the on-line compensation steps utilizing the information stored during the off-line steps are as follows:

1. The forward voltage drops (ΔV) are determined for each LED. In this step, the change in the forward voltage relative to the sensor nominal
20 values are calculated, the nominal values having been stored in the sensor memory unit or in the control unit memory. If the pulse oximeter does not have forward voltage measuring means, the temperature of each LED is estimated by reading the temperature indicated by a sensor on the LED substrate, and either the manufacturer specifications or empirical data for corresponding
25 wavelength changes or a look-up table mapping the emitter drive current to the center wavelength shift is used.

2. The effective extinction matrix for the temperature compensation is determined. This is calculated as illustrated in Eq. 11-13, i.e. using the wavelength shifts determined according to Eq. 11 and calculating the matrix of
30 Eq. 13 using the matrices of Eq. 5 and 12 stored earlier.

3. The DC light transmission for each LED channel (wavelength) is measured, and the value measured is normalized to an emitter current value of 1 mA. The result is the FCTR of the sensor. An estimate for the FLT is then
35 calculated for each emitter (wavelength). In this connection, the FLT values are for calculating the slopes (A and B). In other words, all DC values are

normalized in relation to the 1 mA emitter current in order to make all values comparable to one another.

5. The effective Lambert-Beer extinction coefficients are determined using Eq. 14.

5 6. The extinction coefficients obtained in step 5 are used for solving the analyte concentrations in the Lambert-Beer model.

During the above on-line steps 1-6 in-vivo measurements are performed, wherein the DC component of the radiation emitted through the tissue and received by the detector is measured, tissue-induced changes in the transmission characteristics are determined based on the in-vivo DC component and the transmission characteristics stored, and on the basis of the tissue-induced changes the subject-specific variation in the in-vivo measurement is compensated for.

The above off-line and on-line steps compensate for the non-ideal characteristics of the broadband emitters or for external effects on the light source emission spectra. However, they do not compensate for the variation in the absorption and scattering interplay in the tissue, i.e. the internal effects, which equally influence a single line laser emitter and a broadband LED emitter. Lasers also show shifts in the emission line wavelength as a function of the temperature. Therefore, the lasers are compensated for the temperature and internal tissue effects, but not for the pre-filter tissue-induced spectral shifts.

The compensation step attending to the variations in the internal effects is illustrated in the flow diagram of FIG. 10. Initial measurements are again made in order to determine the nominal DC transmission characteristics of the pulse oximeter (steps 101 and 102). As a result of these steps, reference data are created and stored, and the data indicating the transmission characteristics are determined (step 103). On the basis of the data and the in-vivo measurements made, the tissue-induced change in the average transformation is then determined in connection with the in-vivo measurements (step 104). The new transformation is determined, and finally the concentrations of the analytes are solved in the Lambert-Beer model (step 105). Thus in this embodiment the average transformation stored in the pulse oximeter is changed in a subject-specific manner in order to improve the accuracy of the pulse oximeter. As shown below, in this case during the off-line steps 101-103 partly different data is to be created and stored as compared to

the first compensation step, since in this case the DC light transmission characteristics are used to create a subject-specific transformation.

A practical implementation of the second compensating step is now discussed by introducing a new variable called "path length multiplier", since
 5 this will provide an easy way of understanding the technique in accordance with the invention.

As mentioned above, the purpose of the invention is to improve the accuracy of a pulse oximeter in situations in which the blood volume, the red blood cell density or the hematocrit, the total hemoglobin (g/dl), the division
 10 between the arterial and venous blood compartment volumes, and the arterial-venous saturation difference vary and produce human variability, which worsens the accuracy of the SpO2 measurement. It is also the purpose of the invention to compensate for the effect of skin pigmentation (dark skin), which in part can be considered to belong to the tissue prefilter category of
 15 compensations, but which also influences via modifying the path length multiplier. This modification is especially important for SpO2 ear sensors, which are attached to a very thin tissue part (of about the same thickness corresponding to the diffusion constant in human tissue).

The interdependence of the above-described transformation and the
 20 path length multiplier is first illustrated by considering the photon path lengths through a single layer of artery blood and examining how the scattering and absorption affect it. It is postulated here that multiple scattering effectively increases the photon path length through the artery and that the absorption of the surrounding tissue effectively decreases it. In this way the artery and tissue
 25 are in interaction with each other. To derive a mathematical formulation of this relationship, the known Kubelka-Munk two-flux model can be used. This model defines an absorption probability K as follows:

$$K = \left\langle \frac{dl}{dz} \right\rangle * \Sigma_a \quad (15),$$

where Σ_a is the macroscopic absorption cross-section of the media
 30 and dl is the true average photon path length through the scattering and absorbing medium of infinitesimal layer thickness dz . The term $\langle dl/dz \rangle = K/\Sigma_a$ is a path length multiplier (ρ/m) which enhances the arterial blood absorption from that of the Lambert-Beer non-scatter value because of the multiple scattering in the surrounding medium.

The idea of the path length multiplier is applied to the Lambert-Beer formulation of 2- λ pulse oximetry. The ratio of the change in absorption at the two probe wavelengths is defined as:

$$\frac{dA_k}{dA_l} = N_{kl}^{in-vivo} = \frac{\mu_a^k * d_k}{\mu_a^l * d_l} \quad (16),$$

- 5 where μ_a^l is the arterial (non-scatter) absorption coefficient at wavelength l and d_l is the effective true optical path length. The transformation is defined by substituting equation 15 with $dl = d_l$ in equation 16:

$$N_{kl}^{in-vivo} = \frac{\mu_a^k * \left(\frac{K}{\Sigma_a}\right)_k * dz}{\mu_a^l * \left(\frac{K}{\Sigma_a}\right)_l * dz} = \frac{\left(\frac{K}{\Sigma_a}\right)_k}{\left(\frac{K}{\Sigma_a}\right)_l} * N_{kl}^{ideal} \quad (17),$$

- 10 where the ideal Lambert-Beer model is used for $N_{kl}^{ideal} \equiv \mu_a^k / \mu_a^l$, and where the layer thickness dz is the same for all wavelengths (k, l). Equation 17 now represents the transformation $(g_{kl})^{-1}$ from $N_{kl}^{in-vivo}$, i.e. from the measured value, to N_{kl}^{L-B} , which is the ratio of differential absorptions that would be measured if the measurement system were the ideal cuvette system of the Lambert-Beer model. For the transformation the equation below is obtained:

$$15 \quad g_{kl} = \frac{\left(\frac{K}{\Sigma_a}\right)_k}{\left(\frac{K}{\Sigma_a}\right)_l} = \frac{plm_k}{plm_l} \quad (18).$$

- Thus the transforming quantity is a ratio of path length multipliers measured at two different wavelengths (k and l). The dependence of the function g_{kl} thus refers to the absorption density of the scattering tissue in the surrounding of the infinitesimal arterial layer dz including the layer itself. This essentially means that the transformation does not require knowledge of the analyte composition in the arterial blood, but refers rather to the macroscopic light absorption, i.e. transmission through the tissue part under the sensor. That is in the language of pulse oximetry the DC component of the light transmission. This is utilized in the compensation of the invention.

- 25 Modifying Eq.1 and leaving the attenuation of the probe design factors (i.e. CTR values) out of consideration, the relationship of the DC light

transmission through the tissue and the path length multiplier can be presented as follows:

$$I_{out} = I_{in} e^{-\varepsilon DC} = I_{in} e^{-\varepsilon plm D1 C} \quad (19),$$

where D is the actual path length through the sample, $D1$ is the shortest path length through the sample (i.e. the thickness of the sample), and ε is the ideal extinction coefficient of the analyte. Here the I_{out}/I_{in} can be associated with the FLT at the wavelength in question. Plm thus describes the internal attenuation factors in the tissue and, in particular, the enhancement of the absorbancy relative to the ideal cuvette absorption.

In nominal conditions, the path length multiplier has a certain nominal value plm^0 (where the superscript '0' refers to the nominal value). This nominal value can be determined in the factory at the manufacturing stage of the pulse oximeter. When the DC component is measured again in connection with in-vivo measurement, the change in the plm from the nominal value can be used to determine the change in the average transformation.

The term α_{int} in Eq. 6 can be expressed with the help of the path length multiplier in the Lambert-Beer model as

$$\alpha_{int} = plm * \Sigma_a,$$

where Σ_a accounts for all internal absorption sources and is defined in the non-scatter Lambert-Beer domain. The FLT at wavelength k can then be written as follows:

$$FLT_k = \exp(-\alpha_{int} * d) = \exp(-plm * \Sigma_a * d) \quad (20).$$

We then ratio the logarithms of the FLTs at two wavelengths k and l , which results in Eq. 21:

$$\frac{\log(FLT_k)}{\log(FLT_l)} = \frac{plm_k * \Sigma_a^k}{plm_l * \Sigma_a^l} = g_{kl} * \frac{f_a * \mu_a^k + f_v * \mu_v^k}{f_a * \mu_a^l + f_v * \mu_v^l} = g_{kl} * \frac{f_a(\mu_a^k - \mu_v^k) + \mu_v^k}{f_a(\mu_a^l - \mu_v^l) + \mu_v^l} \quad (21),$$

where $g_{kl} = plm_k / plm_l$ is the transformation between the Lambert-Beer and in-vivo modulation ratios according to Eq. 18, and in which the internal absorbing tissue compartments are venous and arterial blood with volume fractions f_v and f_a and with absorption coefficients μ_v and μ_a determined in the Lambert-Beer domain, respectively. In the last expression we have used for the venous volume fraction the relationship $f_v = 1 - f_a$. As the arterial volume fraction is always smaller than the venous volume fraction and as the arterial-

venous absorption difference is always smaller than the venous absorption, the dominating factor in the last term is μ_v^k / μ_v^l , i.e. the venous saturation SvO2.

Thus the changes in the FLT and SvO2 from their nominal values provide the compensation needed for estimating the correct transformation function g_{kl} . We can then finally write for the relative change of the transformation function g_{kl} :

$$\frac{g_{kl}}{g_{kl}^0} = \frac{\frac{\log(FLT_k)}{\log(FLT_l)} \frac{\log(FLT_k)^0}{\log(FLT_l)^0}}{F_{kl}(SvO2, SaO2, f_a) / F_{kl}(SvO2, SaO2, f_a)^0} \quad (22),$$

where the function F_{kl} represents the ratio term $\frac{f_a(\mu_a^k - \mu_v^k) + \mu_v^k}{f_a(\mu_a^l - \mu_v^l) + \mu_v^l}$ in

Eq. 21 and the superscript 0 represents the nominal values of the nominal calibration function g_{kl}^0 , which is on average true for a large patient population. In fact, the $\log(FLT)$ and the F_{kl} compensation terms account for quite different human variability factors in the tissue: whereas F_{kl} mainly tracks the changes of the arterial venous saturation difference, in particular SvO2, the $\log(FLT)$ reflects the changes in the total absorption of the tissue, i.e. in the total blood volume and the total hemoglobin or hematocrit, which are not seen in F_{kl} at all. In practice, the largest corrections to the transformation function are due to the $\log(FLT)$ and F_{kl} is less important.

The FLT in Eq. 22 is easily obtained at the two wavelengths k and l , as has been described earlier in Eq. 7. The function F_{kl} represents the ratio of the absorption coefficients (in the Lambert-Beer non-scatter model) of the whole tissue at these same two wavelengths, i.e. it represents the internal color of the tissue. This internal absorption ratio can be measured by examining the low frequency baseline fluctuations of the plethysmographic wave signal. These fluctuations are caused by the low frequency changes (usually of respiration origin) in the blood volume or in the blood volume distribution of the tissue. Similarly, since the arterial color (= R-ratio) is defined as the ratio of the arterial absorption coefficients, function F_{kl} can be calculated as:

$$F_{kl} = \frac{f_a(\mu_a^k - \mu_v^k) + \mu_v^k}{f_a(\mu_a^l - \mu_v^l) + \mu_v^l} = g_{kl}^{-1} \left(\frac{(AC/DC)_k}{(AC/DC)_l} \right) = g_{kl}^{-1}(N_{kl}^{baseline}) \quad (23),$$

where AC is the amplitude (or the instantaneous slope) of the low frequency baseline fluctuation, instead of the heart pulse amplitude of the plethysmographic wave, and DC is the DC light transmission at that particular wavelength. Because the effective tissue color is mainly determined by the venous blood, function F_{kl} can be approximated as the arterial modulation ratio calculated for the venous saturation, which is usually about SaO₂-10% i.e. $F_{kl}=R(SvO_2=SaO_2-10\%)$.

If the venous saturation is determined by venous blood samples and the arterial saturation by the arterial blood samples, the function F_{kl} can be calculated using the real blood values (with the assumption that the corresponding blood compartment volumes are $f_a=0.25$ and $f_v=0.75$).

The second compensation step for human variability can then be performed in the following way:

1. The nominal light transmission through a finger or ear lobe or its approximation at the distinct nominal wavelengths of the sensor, is determined for a population of patients or volunteers or even for only one single volunteer, on whom the nominal calibration (the original standard pulse oximeter calibration or the actual multi wavelength measurements using this calibration directly or indirectly) was performed; this gives $\frac{\log(FLT_k^0)}{\log(FLT_l^0)}$ as a function of $N_{kl}^{in-vivo}$ at these wavelengths (k, l), i.e. as a function of the correct SpO₂ in practice. Thus, the FLT^0 values are obtained for each wavelength. This information is stored in the sensor memory unit (or in the control unit).

2. Function F^0 can be determined in two alternative ways:

2.1 In the above measurement using the baseline fluctuations, $N_{kl}^{baseline}$ is calculated and transformed to the Lambert-Beer model by the nominal transformation $(g_{kl}^0)^{-1}$ for the population of patients or volunteers or even for only one single volunteer, on whom the nominal calibration (the original standard pulse oximeter calibration or the actual multi-wavelength measurements using this calibration directly or indirectly) was performed; this is tabulated as a function of $N_{kl}^{in-vivo}$ at these wavelengths (k, l). These data are stored in the sensor memory unit (or in the control unit).

2.2. In the above measurement venous and arterial blood samples are taken from a position close to the sensor site and analyzed for RHb, HbO₂, HbCO, and methHb. The absorption coefficients μ_a and μ_v are then calculated using the measured analyte fractions. The arterial volume fraction f_a is then estimated. Usually it is sufficient to approximate that f_a is equal to 0.25. The functions F_{kl} are calculated in the Lambert-Beer Model using the venous and arterial volume fractions and

5

$$\mu_{a,v} = RHb * \mu_{a,v}^{RHb} + HbO_2 * \mu_{a,v}^{HbO_2} + HbCO * \mu_{a,v}^{HbCO} + metHb * \mu_{a,v}^{metHb}$$

3. As a result of steps 1 and 2, we have an off-line determined look-up table for each wavelength pair, in which the following nominal information is tabulated:

10

k	l	$N_{kl}^{in-vivo}$	g_{kl}^0	$\text{Log}(FLT_k)/\text{log}(FLT_l)$	$g_{kl}^{-1} \times (N_{kl}^{baseline})$	F_{kl}

Table 1.

and where also the nominal transformation g^0 is presented and $N_{kl}^{baseline} \cong g_{kl}^0 \times (F_{kl})$. Only one of the two last columns is necessary, depending on the way the values of function F are determined. It is also to be noted that the ratio is not necessary in column 5, but that it is enough to store the FLT values from which the ratio of their logarithms can be calculated.

15

As is obvious from the above, steps 1-3 again include measuring the DC light transmission of the apparatus, establishing nominal DC transmission characteristics for the apparatus on the basis of the measurements, and storing reference data for subsequent in-vivo measurements, the data indicating the transmission characteristics established.

20

After the above off-line steps, which can be performed at the manufacturing stage of the pulse oximeter, the following steps are performed in connection with the on-line (i.e. in-vivo) measurement.

25

4. The actual spectral shape of the light transmission through a finger or ear lobe at the distinct wavelengths of the sensor is determined, and $\frac{\text{log}(FLT_k)}{\text{log}(FLT_l)}$ is calculated for each wavelength pair similarly as in the off-line

30

stage.

5. In Table 1 in the row where the measured modulation ratio at the wavelengths k and l equals $N_{kl}^{\text{in-vivo}}$, the nominal $\frac{\log(FLT_k)^0}{\log(FLT_l)^0}$ is read. The correction factor $\frac{\log(FLT_k)}{\log(FLT_l)} / \frac{\log(FLT_k)^0}{\log(FLT_l)^0}$ is then calculated.

6. In Table 1 in the row, where the measured modulation ratio at the wavelengths k and l equals $N_{kl}^{\text{in-vivo}}$, the nominal F_{kl}^0 is read from either of the last two columns.

7. The correction factor F_{kl}/F_{kl}^0 is determined in one of the following two ways:

7.1 Column $g^{-1} \times (N^{\text{baseline}})$: By using the baseline fluctuations of the measured plethysmographic wave and by using Eq. 23 with g^{-1} , the function F_{kl} is determined. The correction factor F_{kl}/F_{kl}^0 is then calculated. For determining N^{baseline} and its changes, the amplitudes of the signal can be used, as is normally done for a modulation ratio N .

7.2 Column F_{kl} : The blood analytes RHB, HbO₂, HbCO, and metHb are solved in the Lambert-Beer model using the nominal transformation g^0 . This is the first approximation for the analytes. The absorption coefficients μ_a and μ_v are calculated using the measured analyte fractions in the arterial absorption and approximating the absorption coefficient in the venous blood by using the measured dyshemoglobin fractions and setting $HbO_2^{\text{vena}} = HbO_2 - 10\%$ and $RHb^{\text{vena}} = RHb + 10\%$, where $f_a = 0.25$ is assumed. The functions F_{kl} are calculated in the Lambert-Beer Model using the equation:

$$\mu_{a,v} = RHb * \mu_{a,v}^{RHb} + HbO_2 * \mu_{a,v}^{HbO_2} + HbCO * \mu_{a,v}^{HbCO} + metHb * \mu_{a,v}^{metHb}.$$

A more accurate estimate of F_{kl} can be obtained by iteration of new analyte fractions for the new corrected transformation after step 8.

8. A new transformation g_{kl} is calculated using Eq. 22, and the new transformation is used for solving the analyte concentrations in the Lambert-Beer model.

The pre-calculated data utilized by the pulse oximeter can be stored in the sensor part of the pulse oximeter, whereby the same sensor can be attached to different pulse oximeter housings. FIG. 12 illustrates the general structure of a sensor according to the invention, the detailed configuration of the sensor being dependent on which information is stored in the sensor and

which in the signal processing part, and also on the amount of the calculation appropriate in the signal processing part.

Nevertheless, a sensor according to the invention includes the light sources (10a-10c) and the photo detector (12), the light sources being adapted to emit at two or more wavelengths. In addition, the sensor includes a data storage unit M2 for storing the data on the basis of which the signal processing part can perform the above-described calibration. The information necessary for the above compensations is shown in the figure. For the first compensation process the pulse oximeter needs the k-values, the above-mentioned three matrices, i.e. the nominal extinction matrix (Eq. 5), the shift matrices (Eqs. 9 and 12), and the CTR/wavelength pairs. For the second compensation process, in turn, the pulse oximeter needs the information stored in Table 1 and the CTR/wavelength pairs. As mentioned above, at least part of this data determined prior to the use of the device for in-vivo measurements can also be stored in the control unit part of the pulse oximeter. The apparatus further preferably includes means 120 for measuring the forward voltage of the p-n junction of each LED, as discussed above.

As can be seen from the above, the method of the invention is based on the DC transmission of light. By means of the off-line DC measurements, reference data is first created. During subsequent in-vivo DC measurements, the reference data is then utilized to filter out human variability from the in-vivo measurement.

Although the method in accordance with the invention has been discussed in connection with a four wavelength pulse oximeter, it can also be employed in a basic two wavelength pulse oximeter. However, the method is more beneficial in a multi-wavelength pulse oximeter where the number of analytes to be measured is greater than two.

In the case of a two-wavelength pulse oximeter, the simplest way to apply the compensation is first to formulate the calibration of the two-wavelength oximeter as a first step using only one transformation function g^{-1} (e.g. at wavelengths 660nm and 900 nm) and a second step using a two-times-two extinction matrix ϵ for these wavelengths and for the two analytes RHb and HbO₂. The compensation procedures are then identical to the ones presented in the above multi-wavelength method. If the calibration of the two-wavelength pulse oximeter is done in the normal way using a direct mapping of the in-vivo measured R-ratio (= $N_{660-900}$) to the SpO₂ percentage, the

compensation steps could for example, be as follows: The wavelength shifts from the nominal LED center wavelength values to a change in the SpO₂ value can first be coded. The wavelength shifts are determined for the temperature component as described in the above multi-wavelength method and for the tissue component by mapping at the two wavelengths the change in the FLT ratio from its nominal value in the calibration conditions to a change in the SpO₂ value from the nominal calibration SpO₂. The tissue wavelength shift cannot be estimated as accurately as in the multi-wavelength oximeter, but sufficient compensation to the tissue prefilter can still be obtained and the accuracy of the pulse oximeter can be improved. The last compensation step also includes the compensation for the internal tissue variability, which is summed with the prefilter effect.

Although the invention has been described above with reference to the examples shown in the appended drawings, it is obvious that the invention is not limited to these, but may be modified by those skilled in the art without departing from the scope and spirit of the invention. For example, instead of transformation, any other quantity by which the pulse oximeter can correct the average calibration known to it can be used to eliminate human variability.

The invention has also been described with reference to pulse oximeters for analytes which are in the blood of a subject. The invention, however, can also be applied at different wavelength ranges, e.g. at around 1.5 μm for glucose, at which similar compensation means are called for. The other substances in the tissue modify the effective extinction of the glucose because they alter the path length multiplier at this wavelength. Similarly, the tissue prefilter and temperature effects are taken into account.

Claims

1. A method for compensating for subject-specific variability in an apparatus intended for non-invasively determining the amount of at least two light-absorbing substances in the blood of a subject and provided with emitter means for emitting radiation at a minimum of two different wavelengths and with detector means for receiving the radiation emitted, characterized by the steps of:
- calibrating the apparatus using a nominal calibration,
 - carrying out initial characterization measurements, said measurements to include measuring radiation received by the detector,
 - based on the characterization measurements, establishing nominal characteristics describing conditions under which the nominal calibration is used,
 - storing reference data indicating the nominal characteristics established,
 - performing in-vivo measurements on a living tissue, wherein radiation emitted through the tissue and received by the detector means is measured,
 - based on the in-vivo measurements and the reference data stored, determining tissue-induced changes in the nominal characteristics, and
 - compensating for subject-specific variation in the in-vivo measurements by correcting the nominal calibration on the basis of the tissue-induced changes.
2. A method according to claim 1, including compensation for effects causing wavelength shift.
3. A method according to claim 1, including compensation for effects internal to the tissue.
4. A method according to claim 1, including both compensation for effects causing wavelength shift and for effects internal to the tissue.
5. A method according to claim 2, wherein the compensation for effects causing wavelength shift includes defining subject-specific extinction coefficients for the substances.
6. A method according to claim 3, wherein the compensation for effects internal to the tissue includes defining a subject-specific transformation used to transform in-vivo measurement results to the Lambert-Beer model.

7. A method according to claim 4, wherein the compensation for effects causing wavelength shift includes defining subject-specific extinction coefficients for the substances, and the compensation for effects internal to the tissue includes defining a subject-specific transformation used to transform
5 in-vivo measurement results to the Lambert-Beer model.

8. A method according to claim 5, wherein said establishing step includes determining DC transmission characteristics of the emitter and detector means, spectral characteristics of the emitter and detector means and nominal transmission characteristics for the tissue.

10 9. A method according to claim 8, wherein said establishing step further includes determining the temperature in which the nominal calibration is used.

10. A method according to claim 9, wherein the extinction coefficients ϵ_{ij} are determined according to the following formula:

15
$$\epsilon_{ij}^{effective} = \frac{1}{W} \int_{\Delta\lambda} \epsilon_j(\lambda) * LED_i(\lambda(T)) * DET(\lambda) * tissue(\lambda) \partial\lambda,$$

where the integration is over the emission spectrum $LED_i(\lambda)$ of the emitter means, $DET(\lambda)$ represents the spectral sensitivity of the detector means, $tissue(\lambda)$ is the spectral transmission of radiation through the tissue, ϵ_j is the extinction coefficient of the substance, T is the temperature, and i and j
20 are matrix indices.

11. A method according to claim 10, wherein

- the step of establishing nominal characteristics includes defining a nominal extinction matrix with a nominal extinction coefficient for each substance/wavelength pair, and

25 - the step of determining tissue-induced changes includes updating the nominal extinction matrix, whereby the updated matrix includes the subject-specific extinction coefficients to be used in the Lambert-Beer model.

12. A method according to claim 11, wherein the nominal extinction matrix is determined according to the following formula

30
$$\epsilon_{ij}^{effective} = \frac{1}{W} \int_{\Delta\lambda} \epsilon_j(\lambda) * LED_i(\lambda(T)) * DET(\lambda) \partial\lambda$$

where the integration is over the emission spectrum $LED_i(\lambda)$ of the emitter means, $DET(\lambda)$ represents the spectral sensitivity of the detector

means; g is the extinction coefficient of the substance, T is the temperature, and i and j are matrix indices.

13. A method according to claim 11, wherein the step of establishing nominal characteristics further includes determining a first shift matrix, the elements of which indicate a relative change in each extinction coefficient, assuming that the slope of the term $tissue(\lambda)$ has a fixed value deviating from zero.

14. A method according to claim 13, wherein the step of determining tissue-induced changes in the nominal characteristics includes defining (1) the slope of the term $tissue(\lambda)$ and (2) the subject-specific extinction coefficients based on the shift matrix and the slope defined.

15. A method according to claim 6, wherein the method further includes the steps of

- storing an average transformation measured for a great number of subjects and
- based on the tissue-induced changes, updating the average transformation, whereby the updated transformation represents the subject-specific transformation.

16. A method according to claim 10, wherein

- the step of establishing nominal characteristics further includes defining temperature dependence of the emitter and detector means, and
- said compensating step includes temperature compensation for the emitter and detector means.

17. A method according to claim 16, wherein the step of establishing nominal characteristics further includes determining a second shift matrix the elements of which indicate a relative change of each extinction coefficient for a predetermined wavelength shift.

18. A method according to claim 17, wherein the step of determining tissue-induced changes in the nominal characteristics includes

- defining a wavelength shift caused by temperature and
- defining subject-specific coefficients based on the shift matrix and the wavelength shift defined.

19. A method according to claim 7, wherein

- the step of defining nominal characteristics includes calculating nominal values for the Functional Light Transmission (FLT) of the apparatus,

- the step of determining tissue-induced changes includes calculating new values for the Functional Light Transmission (FLT) of the apparatus, and the step of compensating includes determining the subject-specific transformation on the basis of the nominal and new values.

5 **20.** A method according to claim 7, wherein

- the step of defining nominal characteristics includes calculating nominal values for function F_{kl} of the apparatus,

- the step of determining tissue-induced changes includes calculating new values for the function F_{kl} of the apparatus, and

10 - the step of compensating includes determining the subject-specific transformation on the basis of the nominal and new values,

wherein the function F_{kl} corresponds to the ratio $\frac{f_a(\mu_a^k - \mu_v^k) + \mu_v^k}{f_a(\mu_a^l - \mu_v^l) + \mu_v^l}$,

15 where μ_v and μ_a are the absorption coefficients of venous and arterial blood, respectively, as determined in the Lambert-Beer domain, f_a is the volume fraction of arterial blood, and the superscripts k and l indicate the wavelength.

21. A method according to claim 20, wherein the nominal and new values for the Function F_{kl} are calculated on the basis of measured fluctuation of the DC component of the radiation received by the detector means.

22. A method according to claim 20, wherein

20 - the step of determining tissue-induced changes includes calculating a first approximation for the amount of the substances, and

- the step of compensating includes utilizing the first approximation for determining the subject-specific transformation.

25 **23.** A method according to claim 1, wherein the at least two light absorbing substances include oxyhemoglobin (HbO₂) and reduced hemoglobin (RHb).

24. An apparatus for non-invasively determining the amount of at least two light absorbing substances in the blood of a subject, characterized in that the apparatus comprises:

30 - emitter means for emitting radiation at a minimum of two different wavelengths,

- detector means for receiving said radiation at each of said wavelengths and producing at least two electrical output signals,

35 - first signal processing means for processing said output signals and producing a modulation signal for each wavelength, each modulation signal

representing the pulsating absorption caused by the arterialized blood of the subject,

- second signal processing means for applying a predetermined calibration on said modulation signals, whereby transformed modulation signals applicable in the Lambert-Beer model are obtained,

- memory means for storing reference data indicating nominal characteristics under which said predetermined calibration has been applied,

- first compensation means, operatively connected to the memory means, for determining tissue-induced changes in the nominal characteristics,

- second compensation means, operatively connected to the first compensation means, for defining a subject-specific calibration by correcting the predetermined calibration on the basis of the tissue-induced changes, and

- calculation means, responsive to the second compensation means, for determining said amounts.

25. A sensor for collecting measurement data for a pulse oximeter intended for non-invasively determining the amount of at least two light absorbing substances in the blood of a subject, characterized in that the sensor comprises:

- means for emitting radiation at a minimum of two different wavelengths,

- means for receiving said radiation at each of said wavelengths and producing at least two electrical output signals,

- storage means including reference data indicating nominal characteristics describing calibration conditions of the pulse oximeter, said data allowing an apparatus connected to the sensor to determine tissue-induced changes in the nominal characteristics when radiation is emitted through said tissue.

26. A sensor according to claim 25, wherein the means for emitting radiation are Light Emitting Diodes.

27. A sensor according to claim 25, wherein the means for emitting radiation are lasers.

28. A sensor according to claim 25, wherein the means for emitting radiation include radiation conduction means for conducting radiation from the emitting component to the tissue site, at which the measurement is performed.

29. A sensor according to claim 25, wherein the means for receiving radiation include radiation conduction means for conducting radiation from the tissue site to the detector component.

5 30. A sensor according to claim 25, wherein the reference data includes the Functional Light Transmission (FLT) of the apparatus.

31. A sensor according to claim 25, wherein the reference data includes function F_{kl} of the apparatus in nominal conditions,

wherein the function F_{kl} corresponds to the ratio $\frac{f_a(\mu_a^k - \mu_v^k) + \mu_v^k}{f_a(\mu_a^l - \mu_v^l) + \mu_v^l}$,

10 where μ_v and μ_a are the absorption coefficients of venous and arterial blood, respectively, as determined in the Lambert-Beer domain, f_a is the volume fraction of arterial blood, and the superscripts k and l indicate the wavelength.

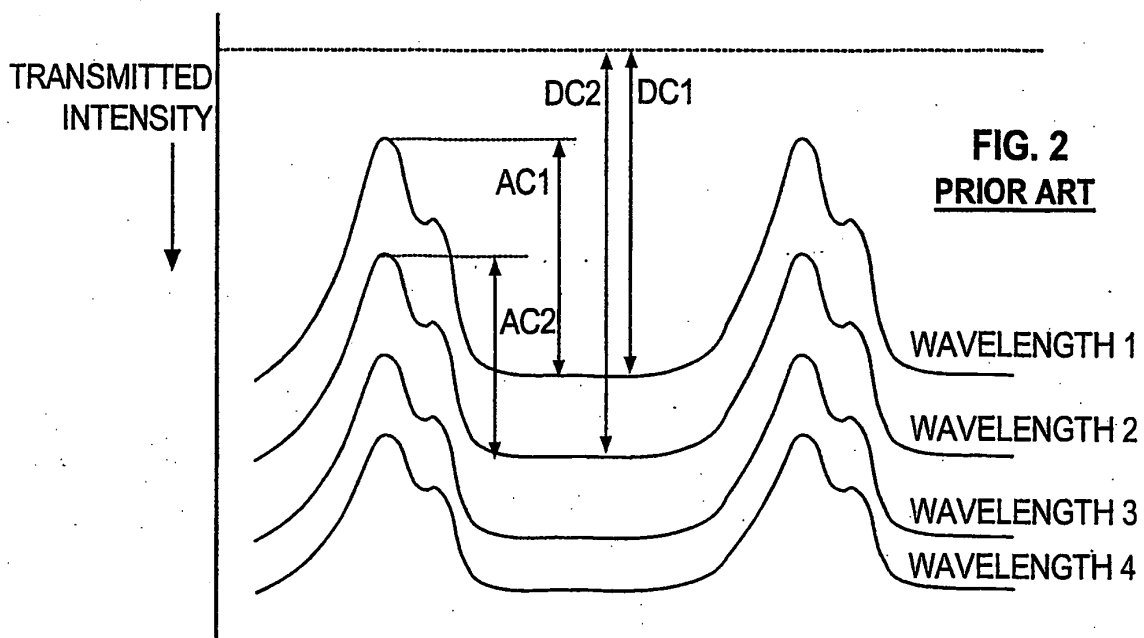
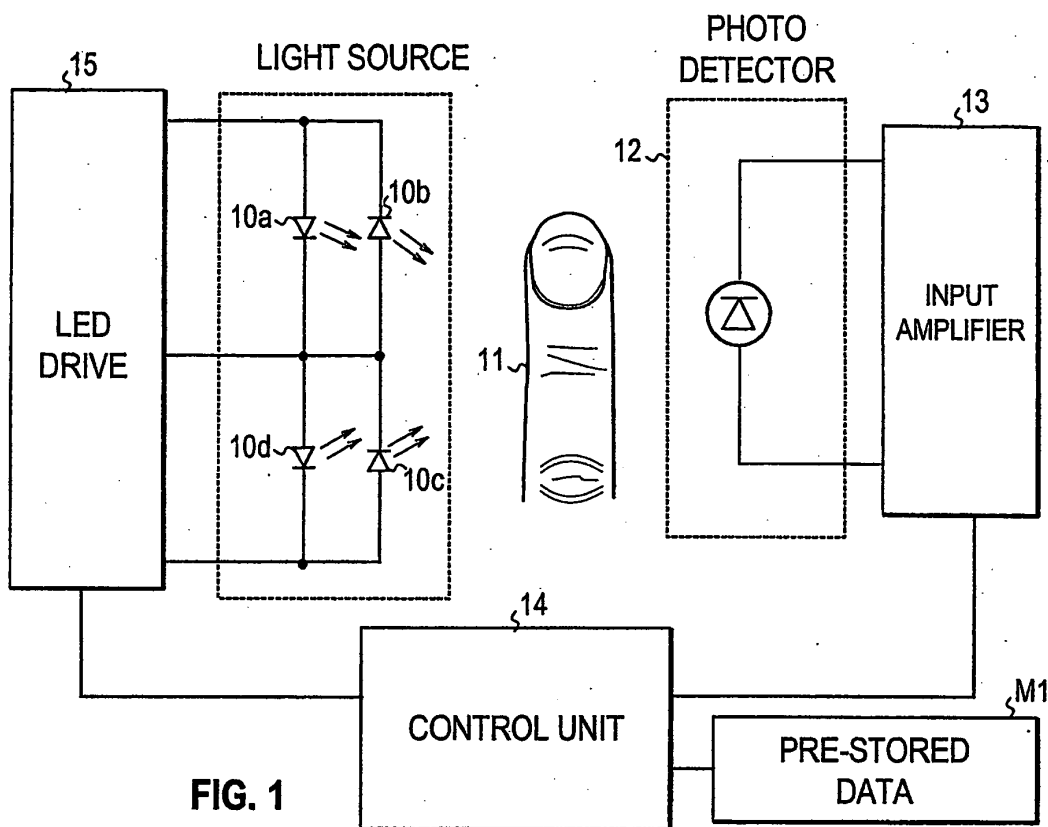

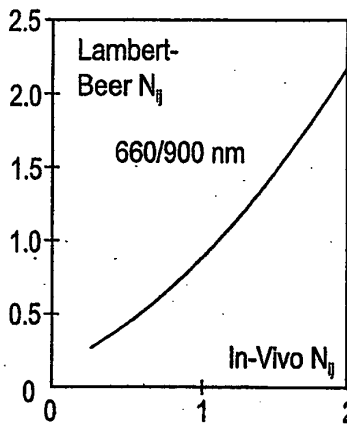
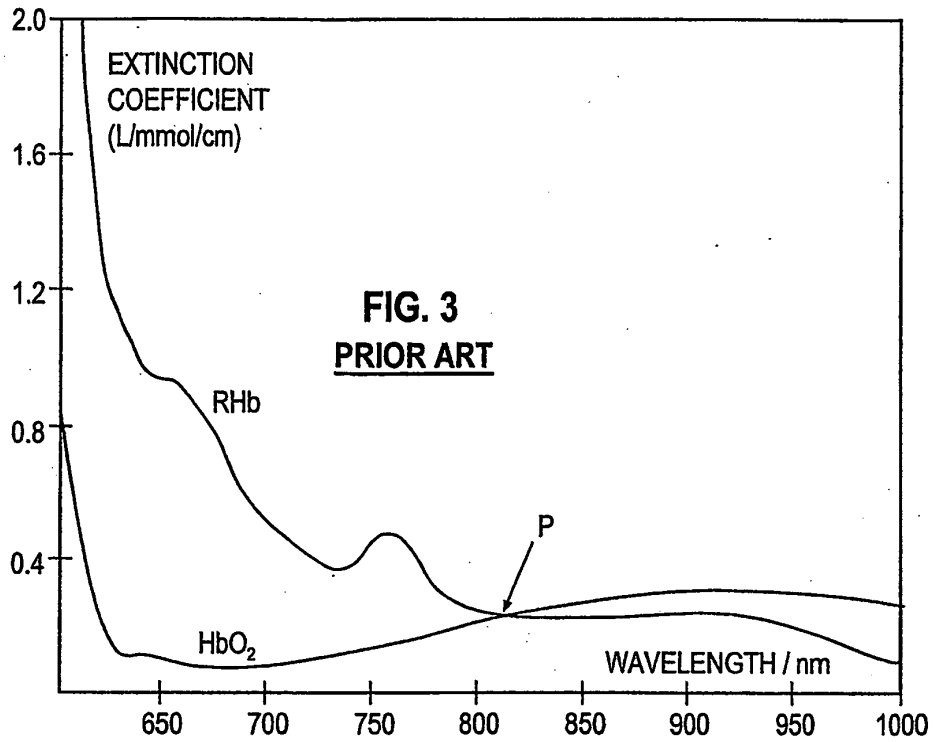

FIG. 4a PRIOR ART

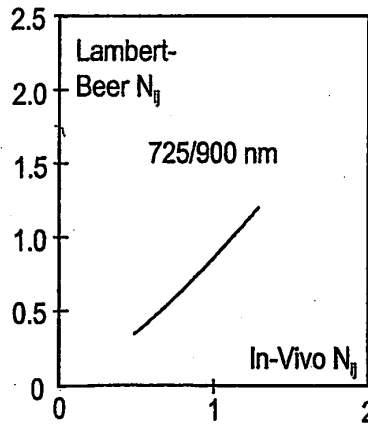

FIG. 4b PRIOR ART

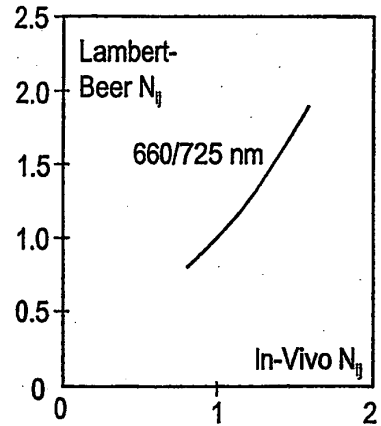

FIG. 4c PRIOR ART

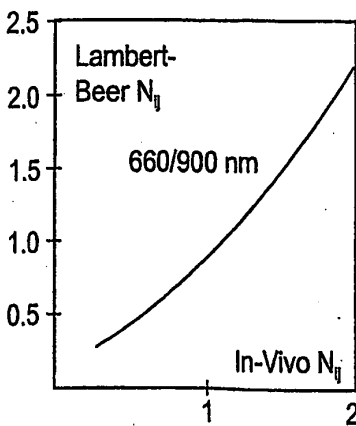

FIG. 4d PRIOR ART

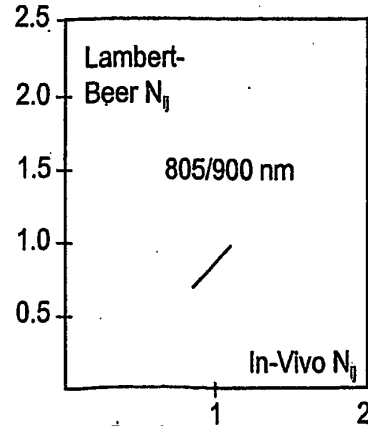

FIG. 4e PRIOR ART

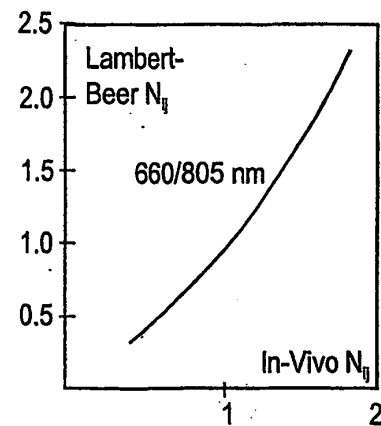

FIG. 4f PRIOR ART

3/6

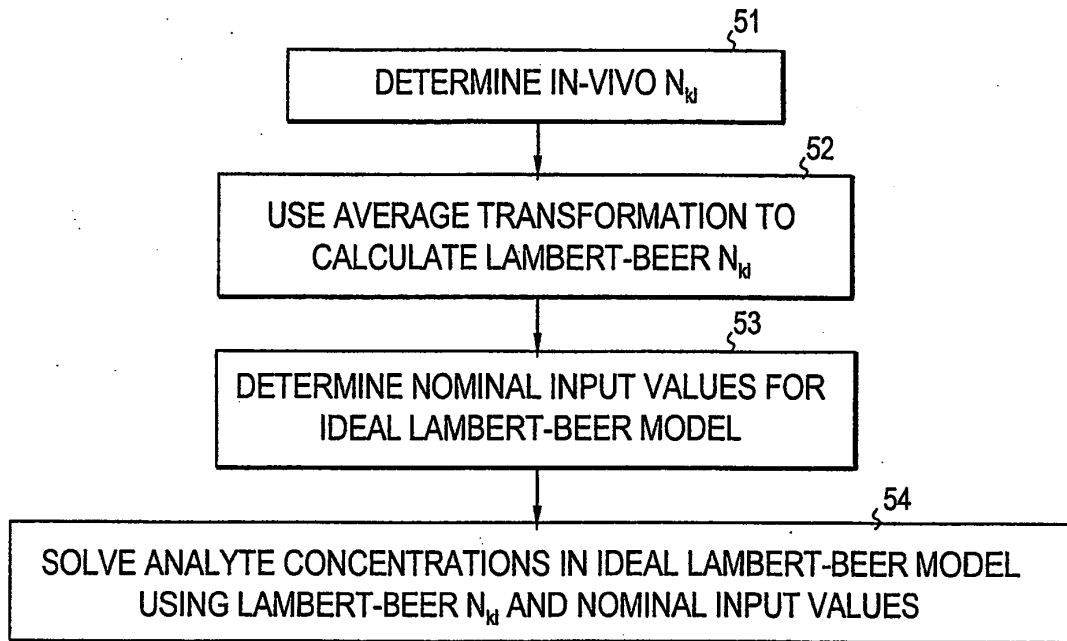

FIG. 5 PRIOR ART

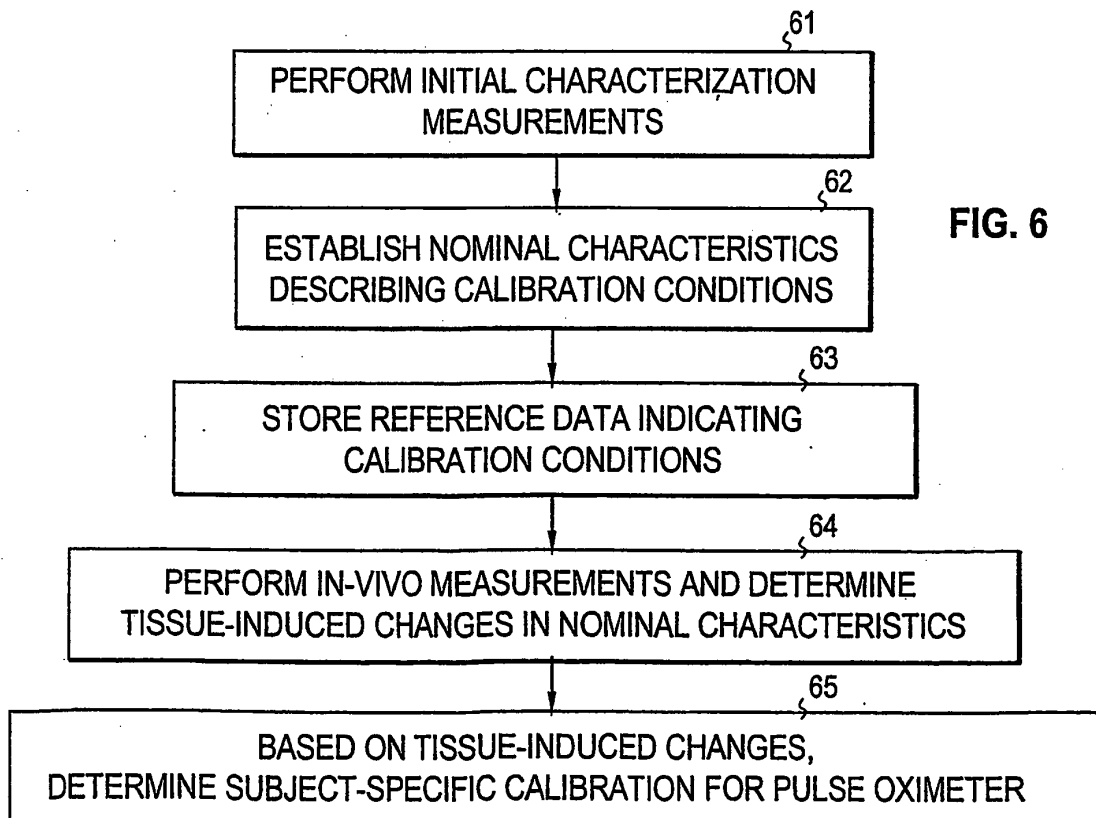

FIG. 6

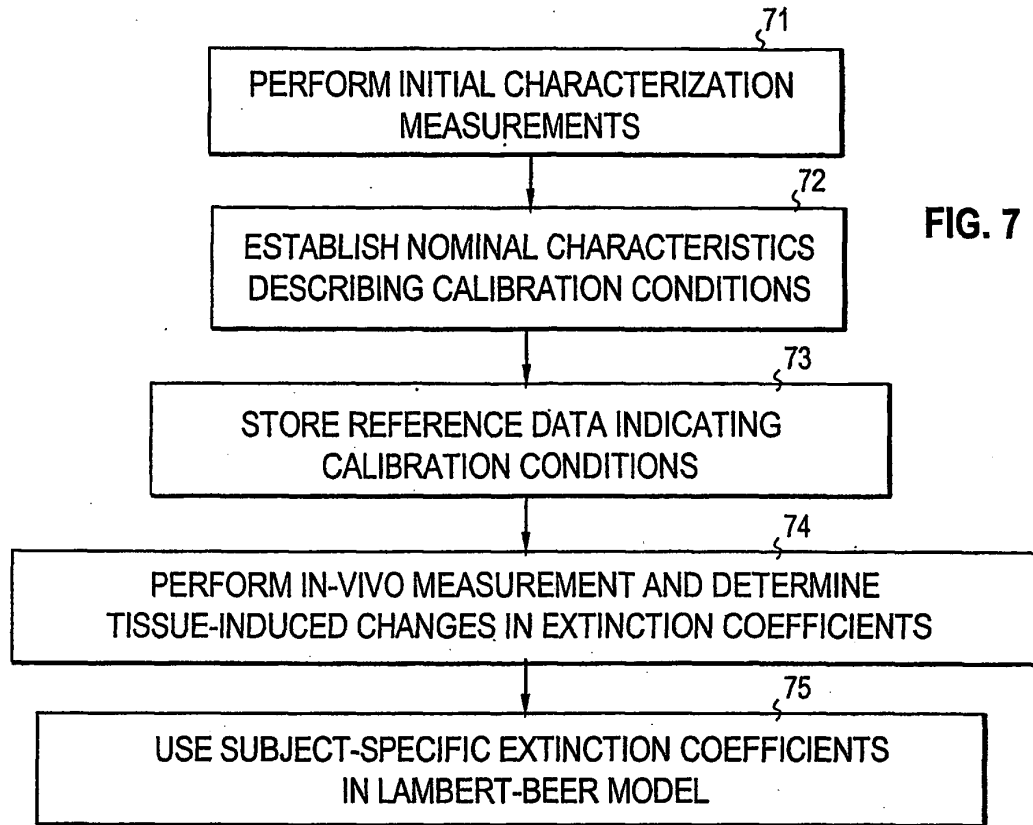

FIG. 7

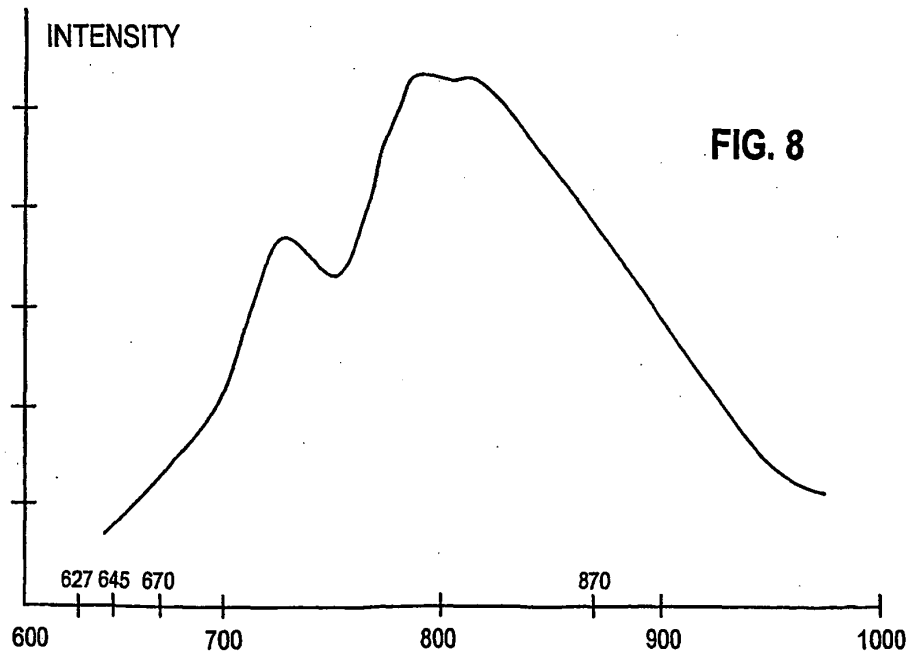

FIG. 8

5/6

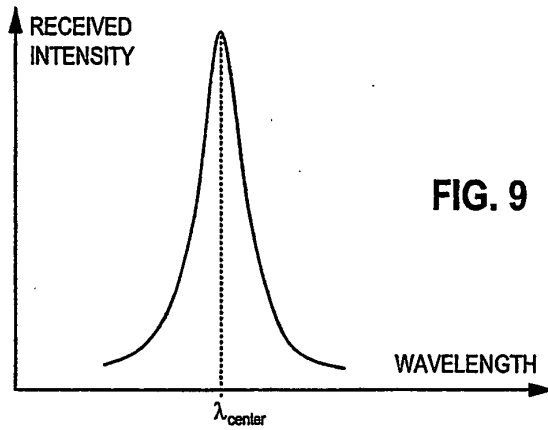

FIG. 9

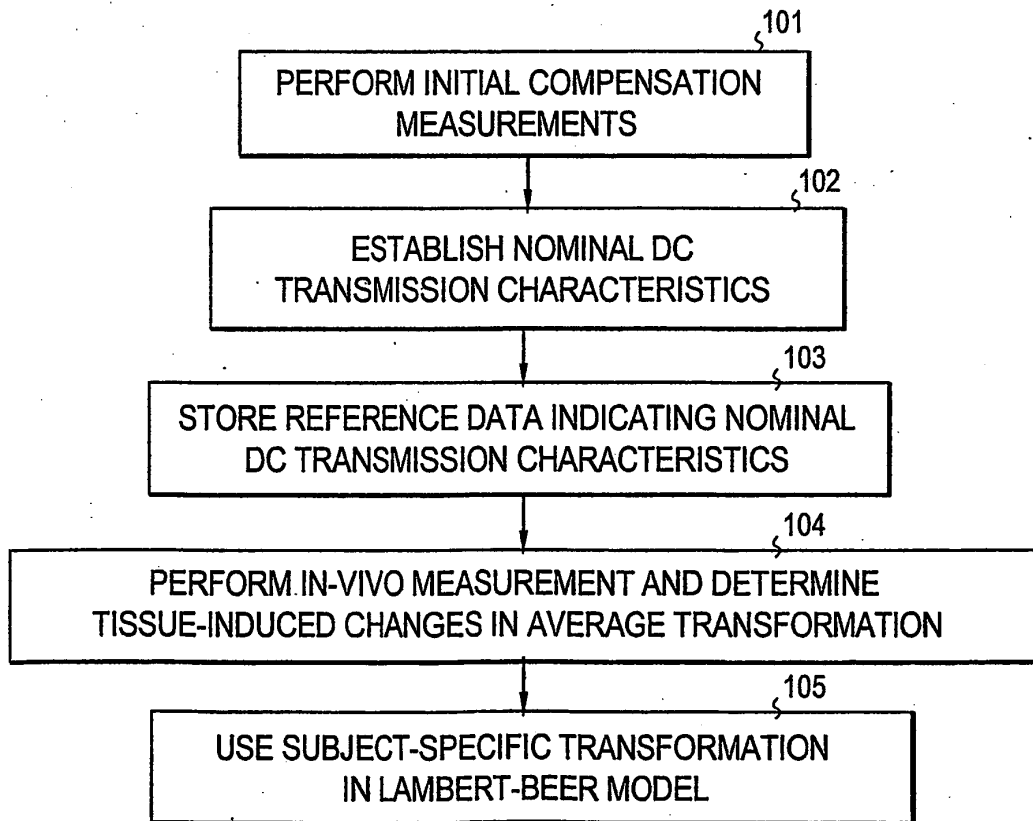

FIG. 10

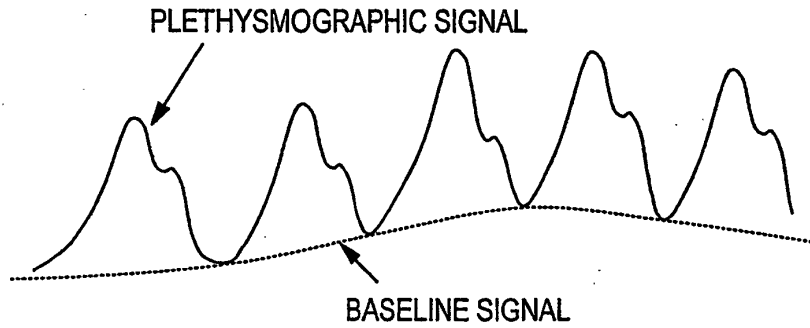

FIG. 11

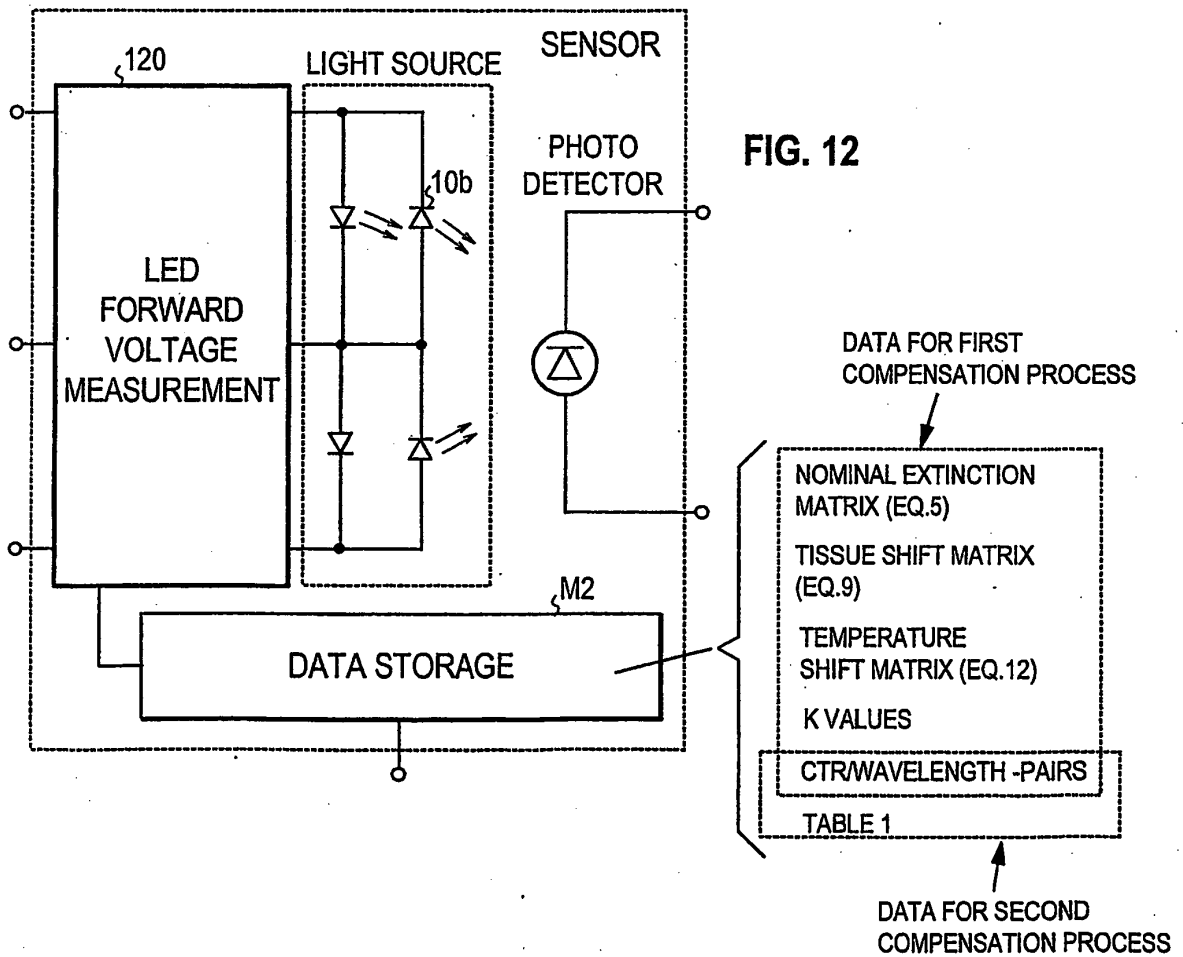

FIG. 12

INTERNATIONAL SEARCH REPORT

International application No.

PCT/FI 03/00089

A. CLASSIFICATION OF SUBJECT MATTER		
IPC7: A61B 5/00 According to International Patent Classification (IPC) or to both national classification and IPC		
B. FIELDS SEARCHED		
Minimum documentation searched (classification system followed by classification symbols)		
IPC7: A61B, G01J		
Documentation searched other than minimum documentation to the extent that such documents are included in the fields searched		
SE,DK,FI,NO classes as above		
Electronic data base consulted during the international search (name of data base and, where practicable, search terms used)		
EPO-INTERNAL, WPI DATA		
C. DOCUMENTS CONSIDERED TO BE RELEVANT		
Category*	Citation of document, with indication, where appropriate, of the relevant passages	Relevant to claim No.
P,A	US 6501974 B2 (HUIKU, M.), 31 December 2002 (31.12.02), the whole document --	1-31
A	WO 0178593 A1 (NELLCOR PURITAN BENNETT INCORPORATED), 25 October 2001 (25.10.01), summary of invention --	1-31
A	US 6216021 B1 (FRANCESCHINI, M.A. ET AL), 10 April 2001 (10.04.01), summary of invention --	1-31
A	US 6151107 A (SCHÖLLERMANN, H. ET AL), 21 November 2000 (21.11.00), summary of invention --	1-31
<input checked="" type="checkbox"/> Further documents are listed in the continuation of Box C. <input checked="" type="checkbox"/> See patent family annex.		
* Special categories of cited documents: "A" document defining the general state of the art which is not considered to be of particular relevance "E" earlier application or patent but published on or after the international filing date "L" document which may throw doubts on priority claim(s) or which is cited to establish the publication date of another citation or other special reason (as specified) "O" document referring to an oral disclosure, use, exhibition or other means "P" document published prior to the international filing date but later than the priority date claimed "T" later document published after the international filing date or priority date and not in conflict with the application but cited to understand the principle or theory underlying the invention "X" document of particular relevance: the claimed invention cannot be considered novel or cannot be considered to involve an inventive step when the document is taken alone "Y" document of particular relevance: the claimed invention cannot be considered to involve an inventive step when the document is combined with one or more other such documents, such combination being obvious to a person skilled in the art "&" document member of the same patent family		
Date of the actual completion of the international search		Date of mailing of the international search report
12 May 2003		15-05-2003
Name and mailing address of the ISA/ Swedish Patent Office Box 5055, S-102 42 STOCKHOLM Facsimile No. +46 8 666 02 86		Authorized officer Pär Moritz /OGU Telephone No. +46 8 782 25 00

INTERNATIONAL SEARCH REPORT

International application No.

PCT/FI 03/00089

C (Continuation). DOCUMENTS CONSIDERED TO BE RELEVANT		
Category*	Citation of document, with indication, where appropriate, of the relevant passages	Relevant to claim No.
A	EP 0800066 A2 (THE PERKIN-ELMER CORPORATION), 8 October 1997 (08.10.97), abstract --	1-3,24-27
A	EP 0748609 A1 (OHMEDA INC.), 18 December 1996 (18.12.96), figures 2,3, abstract -- -----	1-31

INTERNATIONAL SEARCH REPORT

Information on patent family members

29/04/03

International application No.

PCT/FI 03/00089

Patent document cited in search report	Publication date	Patent family member(s)	Publication date
US 6501974 B2	31/12/02	US 2002133068 A WO 02056759 A	19/09/02 25/07/02
WO 0178593 A1	25/10/01	AU 5165401 A EP 1274343 A US 2002035318 A	30/10/01 15/01/03 21/03/02
US 6216021 B1	10/04/01	NONE	
US 6151107 A	21/11/00	DE 59707228 D EP 0914601 A,B ES 2173457 T JP 2000515972 T WO 9804903 A	00/00/00 12/05/99 16/10/02 28/11/00 05/02/98
EP 0800066 A2	08/10/97	CA 2087360 A DE 69315607 D,T EP 0560006 A,B JP 6082307 A JP 2002196130 A KR 264163 B KR 273009 B US 5303165 A	13/08/93 30/04/98 15/09/93 22/03/94 10/07/02 16/08/00 15/11/00 12/04/94
EP 0748609 A1	18/12/96	US 5685301 A	11/11/97

IPW

Please Direct All Correspondence to Customer Number **20995**



**TRANSMITTAL LETTER
INFORMATION DISCLOSURE STATEMENT**

Applicant : Ammar Al-Ali, et al.
 App. No : 11/366,209
 Filed : March 1, 2006
 For : MULTIPLE WAVELENGTH SENSOR
 SUBSTRATE
 Examiner : Unknown
 Art Unit : 3735

CERTIFICATE OF MAILING

I hereby certify that this correspondence and all marked attachments are being deposited with the United States Postal Service as first-class mail in an envelope addressed to: Commissioner for Patents, P.O. Box 1450, Alexandria, VA 22313-1450, on

June 21, 2006

(Date)

[Signature]
Jarom D. Kester, Reg. No. 57,046

Mail Stop Amendment
Commissioner for Patents
P.O. Box 1450
Alexandria, VA 22313-1450

Dear Sir:

Enclosed for filing in the above-identified application are:

- (X) Two Information Disclosure Statements and PTO/SB/08 Equivalents listing references for consideration:
 - (X) Listing 313 references; and
 - (X) Listing 149 references.
- (X) The Commissioner is hereby authorized to charge any additional fees which may be required, or credit any overpayment, to Account No. 11-1410.
- (X) Return prepaid postcard.

[Signature]
 Jarom D. Kester
 Registration No. 57,046
 Attorney of Record
 Customer No. 20,995
 (949) 760-0404



INFORMATION DISCLOSURE STATEMENT

Applicant : Ammar Al-Ali, et al.
 App. No : 11/366,209
 Filed : March 1, 2006
 For : MULTIPLE WAVELENGTH SENSOR
 SUBSTRATE
 Examiner : Unknown
 Art Unit : 3735

CERTIFICATE OF MAILING

I hereby certify that this correspondence and all marked attachments are being deposited with the United States Postal Service as first-class mail in an envelope addressed to: Commissioner for Patents, P.O. Box 1450, Alexandria, VA 22313-1450, on

June 21, 2006

(Date)

Jarom D. Kesler, Reg. No. 57,046

Mail Stop Amendment
 Commissioner for Patents
 P.O. Box 1450
 Alexandria, VA 22313-1450

Dear Sir:

Enclosed for filing in the above-identified application are two PTO/SB/08 Equivalents listing 313 references and 149 references to be considered by the Examiner. Also enclosed are 0 foreign patent references and/or non-patent literature as listed on the Information Disclosure Statement.

This Information Disclosure Statement is being filed before the receipt of a first Office Action on the merits, and presumably no fee is required. If a first Office Action on the merits was mailed before the mailing date of this Statement, the Commissioner is authorized to charge the fee set forth in 37 C.F.R. § 1.17(p) to Deposit Account No. 11-1410.

Respectfully submitted,
 KNOBBE, MARTENS, OLSON & BEAR, LLP

Dated: 6/21/06

By: [Signature]
 Jarom D. Kesler
 Registration No. 57,046
 Attorney of Record
 Customer No. 20,995
 (949) 760-0404

**INFORMATION DISCLOSURE
STATEMENT BY APPLICANT**

(Multiple sheets used when necessary)

SHEET 1 OF 13

Application No.	11/366,209
Filing Date	March 1, 2006
First Named Inventor	Ammar Al-Ali et al.
Art Unit	3735
Examiner	
Attorney Docket No.	MLR.004A

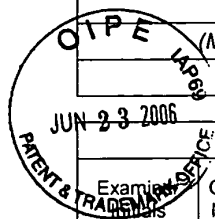

U.S. PATENT DOCUMENTS

Examination Number	Cite No.	Document Number Number - Kind Code (if known) Example: 1,234,567 B1	Publication Date MM-DD-YYYY	Name of Patentee or Applicant	Pages, Columns, Lines Where Relevant Passages or Relevant Figures Appear
	1	7,006,856	02-28-2006	Baker, Jr. et al.	
	2	7,001,337	02-21-2006	Dekker	
	3	6,987,994	01-17-2006	Mortz	
	4	6,975,891	12-13-2005	Pawluczyk	
	5	6,944,487	09-13-2005	Maynard, et al.	
	6	6,931,269	08-16-2005	Terry	
	7	6,928,311	08-09-2005	Pawluczyk et al.	
	8	6,922,645	07-26-2005	Haaland et al.	
	9	6,921,367	07-26-2005	Mills	
	10	6,919,566	07-19-2005	Cadell	
	11	6,917,422	07-12-2005	Samsoondar et al.	
	12	6,912,049	06-28-2005	Pawluczyk et al.	
	13	6,882,874	04-19-2005	Huiku	
	14	6,869,402	03-22-2005	Arnold	
	15	6,847,835	01-25-2005	Yamanishi	
	16	6,845,256	01-18-2005	Chin et al.	
	17	6,842,702	01-11-2005	Haaland et al.	
	18	6,839,582	01-04-2005	Heckel	
	19	6,839,580	01-04-2005	Zonios, et al.	
	20	6,839,579	01-04-2005	Chin	
	21	6,836,679	12-28-2004	Baker JR. et al.	
	22	6,829,496	12-07-2004	Nagai, et al.	
	23	6,825,619	11-30-2004	Norris	
	24	6,819,950	11-16-2004	Mills	
	25	6,810,277	10-26-2004	Edgar, Jr, et al.	
	26	6,801,799	10-05-2004	Mendelson	

Examiner Signature

Date Considered

*Examiner: Initial if reference considered, whether or not citation is in conformance with MPEP 609. Draw line through citation if not in conformance and not considered. Include copy of this form with next communication to applicant.

T¹ - Place a check mark in this area when an English language Translation is attached.

INFORMATION DISCLOSURE STATEMENT BY APPLICANT	Application No.	11/366,209
	Filing Date	March 1, 2006
	First Named Inventor	Ammar Al-Ali et al.
	Art Unit	3735
<i>(Multiple sheets used when necessary)</i>	Examiner	
SHEET 2 OF 13	Attorney Docket No.	MLR.004A

U.S. PATENT DOCUMENTS					
Examiner Initials	Cite No.	Document Number Number - Kind Code (if known) Example: 1,234,567 B1	Publication Date MM-DD-YYYY	Name of Patentee or Applicant	Pages, Columns, Lines Where Relevant Passages or Relevant Figures Appear
	27	6,801,797	10-05-2004	Mannheimer et al.	
	28	6,788,849	09-07-2004	Pawluczyk	
	29	6,780,158	08-24-2004	Yarita	
	30	6,780,158	08-24-2004	Yarita	
	31	6,778,923	08-17-2004	Norris et al.	
	32	6,773,397	08-10-2004	Kelly	
	33	6,760,609	07-06-2004	Jacques	
	34	6,754,516	06-22-2004	Mannheimer	
	35	6,754,515	06-22-2004	Pologe	
	36	6,748,254	06-08-2004	O'Neil et al.	
	37	6,748,253	06-08-2004	Norris et al.	
	38	6,745,061	06-01-2004	Hicks et al.	
	39	6,741,876	05-25-2004	Scecina et al.	
	40	6,741,875	05-25-2004	Pawluczyk et al.	
	41	6,726,634	04-27-2004	Freeman	
	42	6,725,074	04-20-2004	Kastle	
	43	6,721,584	04-13-2004	Baker JR. et al.	
	44	6,720,734	04-13-2004	Norris	
	45	6,719,705	04-13-2004	Mills	
	46	6,714,805	03-30-2004	Jeon, et al.	
	47	6,714,803	03-30-2004	Mortz	
	48	6,711,503	03-23-2004	Haaland	
	49	6,708,049	03-16-2004	Berson et al.	
	50	6,701,170	03-02-2004	Stetson	
	51	6,697,655	02-24-2004	Sueppel, et al.	
	52	6,694,157	02-17-2004	Stone et al.	

Examiner Signature	Date Considered
*Examiner: Initial if reference considered, whether or not citation is in conformance with MPEP 609. Draw line through citation if not in conformance and not considered. Include copy of this form with next communication to applicant.	

T¹ - Place a check mark in this area when an English language Translation is attached.

INFORMATION DISCLOSURE STATEMENT BY APPLICANT	Application No.	11/366,209
	Filing Date	March 1, 2006
	First Named Inventor	Ammar Al-Ali et al.
	Art Unit	3735
(Multiple sheets used when necessary)	Examiner	
SHEET 3 OF 13	Attorney Docket No.	MLR.004A

U.S. PATENT DOCUMENTS					
Examiner Initials	Cite No.	Document Number Number - Kind Code (if known) Example: 1,234,567 B1	Publication Date MM-DD-YYYY	Name of Patentee or Applicant	Pages, Columns, Lines Where Relevant Passages or Relevant Figures Appear
	53	6,687,620	02-03-2004	Haaland et al.	
	54	6,681,126	01-20-2004	Solenberger	
	55	6,675,106	01-06-2004	Keenan et al.	
	56	6,675,031	01-06-2004	Porges, et al.	
	57	6,671,526	12-30-2003	Aoyagi et al.	
	58	6,668,183	12-23-2003	Hicks et al.	
	59	6,665,551	12-16-2003	Suzuki	
	60	6,662,033	12-09-2003	Casciani et al.	
	61	6,658,277	12-02-2003	Wasserman	
	62	6,657,717	12-02-2003	Cadell et al.	
	63	6,654,623	11-25-2003	Kastle	
	64	6,631,281	10-07-2003	Kastle	
	65	6,628,975	09-30-2003	Fein et al.	
	66	6,622,095	09-16-2003	Kobayashi et al.	
	67	6,618,602	09-09-2003	Levin	
	68	6,615,151	09-02-2003	Seccina et al.	
	69	6,615,064	09-02-2003	Aldrich	
	70	6,614,521	09-02-2003	Samsoondar et al.	
	71	6,606,510	08-12-2003	Swedlow, et al.	
	72	6,606,509	08-12-2003	Schmitt	
	73	6,600,940	07-29-2003	Fein, et al.	
	74	6,594,511	07-15-2003	Stone et al.	
	75	6,591,123	07-08-2003	Fein et al.	
	76	6,584,413	06-24-2003	Keenan et al.	
	77	6,582,964	06-24-2003	Samsoondar et al.	
	78	6,571,113	05-27-2003	Fein, et al.	
	79	6,564,077	05-13-2003	Mortara	

Examiner Signature	Date Considered
*Examiner: Initial if reference considered, whether or not citation is in conformance with MPEP 609. Draw line through citation if not in conformance and not considered. Include copy of this form with next communication to applicant.	

T¹ - Place a check mark in this area when an English language Translation is attached.

INFORMATION DISCLOSURE STATEMENT BY APPLICANT	Application No.	11/366,209
	Filing Date	March 1, 2006
	First Named Inventor	Ammar Al-Ali et al.
	Art Unit	3735
<i>(Multiple sheets used when necessary)</i>		Examiner
SHEET 4 OF 13		Attorney Docket No. MLR.004A

U.S. PATENT DOCUMENTS					
Examiner Initials	Cite No.	Document Number Number - Kind Code (if known) Example: 1,234,567 B1	Publication Date MM-DD-YYYY	Name of Patentee or Applicant	Pages, Columns, Lines Where Relevant Passages or Relevant Figures Appear
	80	6,553,241	04-22-2003	Mannheimer, et al.	
	81	6,546,267	04-08-2003	Sugiura	
	82	6,537,225	03-25-2003	Mills	
	83	6,528,809	03-04-2003	Thomas et al.	
	84	6,526,301	02-25-2003	Larsen et al.	
	85	6,522,398	02-18-2003	Cadell et al.	
	86	6,519,486	02-11-2003	Edgar, Jr., et al.	
	87	6,510,329	01-21-2003	Heckel	
	88	6,505,133	01-07-2003	Hanna	
	89	6,505,061	01-07-2003	Larson	
	90	6,505,060	01-07-2003	Norris	
	91	6,504,943	01-07-2003	Sweatt et al.	
	92	6,501,974	12-31-2002	Huiku	
	93	6,497,659	12-24-2002	Rafert	
	94	6,490,466	12-03-2002	Fein et al.	
	95	6,480,729	11-12-2002	Stone	
	96	6,463,310	10-08-2002	Swedlow et al.	
	97	6,453,184	09-17-2002	Hyogo et al.	
	98	6,441,388	08-27-2002	Thomas et al.	
	99	6,434,408	08-13-2002	Heckel	
	100	6,415,236	07-02-2002	Kobayashi et al.	
	101	6,415,233	07-02-2002	Haaland	
	102	6,415,166	07-02-2002	Van Hoy et al.	
	103	6,411,833	06-25-2002	Baker, Jr. et al.	
	104	6,408,198	06-18-2002	Hanna et al.	
	105	6,397,093	05-28-2002	Aldrich	

Examiner Signature	Date Considered
*Examiner: Initial if reference considered, whether or not citation is in conformance with MPEP 609. Draw line through citation if not in conformance and not considered. Include copy of this form with next communication to applicant.	

T¹ - Place a check mark in this area when an English language Translation is attached.

INFORMATION DISCLOSURE STATEMENT BY APPLICANT	Application No.	11/366,209
	Filing Date	March 1, 2006
	First Named Inventor	Ammar Al-Ali et al.
	Art Unit	3735
(Multiple sheets used when necessary)	Examiner	
SHEET 5 OF 13	Attorney Docket No.	MLR.004A

U.S. PATENT DOCUMENTS					
Examiner Initials	Cite No.	Document Number Number - Kind Code (if known) Example: 1,234,567 B1	Publication Date MM-DD-YYYY	Name of Patentee or Applicant	Pages, Columns, Lines Where Relevant Passages or Relevant Figures Appear
	106	6,397,092	05-28-2002	Norris et al.	
	107	6,393,310	05-21-2002	Kuenstner	
	108	6,377,828	04-23-2002	Chaiken, et al.	
	109	6,374,129	04-16-2002	Chin, et al.	
	110	6,363,269	03-26-2002	Hanna et al.	
	111	6,356,774	01-12-2002	Bernstein et al.	
	112	6,351,658	02-26-2002	Middleman et al.	
	113	6,341,257	01-22-2002	Haaland	
	114	6,330,468	12-11-2001	Scharf	
	115	6,304,767	10-16-2001	Soller et al.	
	116	6,304,675	10-16-2001	Osbourn et al.	
	117	6,298,252	10-02-2001	Kovach et al.	
	118	6,272,363	08-07-2001	Casciani et al.	
	119	6,230,035	05-08-2001	Aoyagi et al.	
	120	6,226,539	05-01-2001	Potratz	
	121	6,157,041	12-05-2000	Thomas et al.	
	122	6,154,667	11-28-2000	Miura et al.	
	123	6,151,518	11-21-2000	Hayashi	
	124	6,112,107	08-29-2000	Hannula	
	125	6,104,938	08-15-2000	Huiku	
	126	6,094,592	07-25-2000	Yorkey et al.	
	127	6,083,172	07-04-2000	Baker JR. et al.	
	128	6,073,037	06-06-2000	Alam et al.	
	129	6,068,594	05-30-2000	Schloemer et al.	
	130	6,064,898	05-16-2000	Aldrich	
	131	6,023,541	02-08-2000	Merchant et al.	

Examiner Signature	Date Considered
*Examiner: Initial if reference considered, whether or not citation is in conformance with MPEP 609. Draw line through citation if not in conformance and not considered. Include copy of this form with next communication to applicant.	

T¹ - Place a check mark in this area when an English language Translation is attached.

INFORMATION DISCLOSURE STATEMENT BY APPLICANT	Application No.	11/366,209
	Filing Date	March 1, 2006
	First Named Inventor	Ammar Al-Ali et al.
	Art Unit	3735
<i>(Multiple sheets used when necessary)</i>		Examiner
SHEET 6 OF 13		Attorney Docket No. MLR.004A

U.S. PATENT DOCUMENTS					
Examiner Initials	Cite No.	Document Number Number - Kind Code (if known) Example: 1,234,567 B1	Publication Date MM-DD-YYYY	Name of Patentee or Applicant	Pages, Columns, Lines Where Relevant Passages or Relevant Figures Appear
	132	6,018,674	01-25-2000	Aronow	
	133	6,018,673	01-25-2000	Chin et al.	
	134	6,014,576	01-11-2000	Raley	
	135	6,006,119	12-21-1999	Soller et al.	
	136	5,999,841	12-07-1999	Aoyagi et al.	
	137	5,995,859	11-30-1999	Takahashi	
	138	5,995,856	11-30-1999	Mannheimer et al.	
	139	5,983,122	11-09-1999	Jarman et al.	
	140	5,978,691	11-02-1999	Mills	
	141	5,954,644	09-21-1999	Dettling	
	142	5,934,277	08-10-1999	Mortz	
	143	5,921,921	07-13-1999	Potratz et al.	
	144	5,919,133	07-06-1999	Taylor	
	145	5,916,154	06-29-1999	Hobbs et al.	
	146	5,910,108	06-08-1999	Solenberger	
	147	5,891,024	04-06-1999	Jarman et al.	
	148	5,885,213	03-23-1999	Richardson et al.	
	149	5,876,348	03-02-1999	Sugo	
	150	5,865,736	02-02-1999	Baker JR. et al.	
	151	5,857,462	01-12-1999	Thomas et al.	
	152	5,853,364	12-29-1998	Baker, Jr., et al.	
	153	5,851,179	12-22-1998	Ritson et al.	
	154	5,851,178	12-22-1998	Aronow	
	155	5,842,979	12-01-1998	Jarman	
	156	5,839,439	11-24-1998	Nierlich et al.	
	157	5,830,137	11-03-1998	Sharf	

Examiner Signature	Date Considered
*Examiner: Initial if reference considered, whether or not citation is in conformance with MPEP 609. Draw line through citation if not in conformance and not considered. Include copy of this form with next communication to applicant.	

T¹ - Place a check mark in this area when an English language Translation is attached.

INFORMATION DISCLOSURE STATEMENT BY APPLICANT	Application No.	11/366,209
	Filing Date	March 1, 2006
	First Named Inventor	Ammar Al-Ali et al.
	Art Unit	3735
<i>(Multiple sheets used when necessary)</i>	Examiner	
SHEET 7 OF 13	Attorney Docket No.	MLR.004A

U.S. PATENT DOCUMENTS					
Examiner Initials	Cite No.	Document Number Number - Kind Code (if known) Example: 1,234,567 B1	Publication Date MM-DD-YYYY	Name of Patentee or Applicant	Pages, Columns, Lines Where Relevant Passages or Relevant Figures Appear
	158	5,827,182	10-27-1998	Raley	
	159	5,823,952	10-20-1998	Levinson et al.	
	160	5,818,985	10-06-1998	Merchant et al.	
	161	5,817,010	10-06-1998	Hibl	
	162	5,810,724	09-22-1998	Gronvall	
	163	5,810,723	09-22-1998	Aldrich	
	164	5,807,247	09-15-1998	Merchant et al.	
	165	5,807,246	09-15-1998	Sakaguchi et al.	
	166	5,803,910	09-08-1998	Potratz	
	167	5,800,349	09-01-1998	Isaacson et al.	
	168	5,793,485	08-11-1998	Gourley	
	169	5,792,052	08-11-1998	Isaacson et al.	
	170	5,790,729	08-04-1998	Pologe et al.	
	171	5,782,756	07-21-1998	Mannheimer	
	172	5,782,237	07-21-1998	Casciani et al.	
	173	5,779,630	07-14-1998	Fein et al.	
	174	5,772,587	06-30-1998	Gratton, et. al	
	175	5,755,226	05-26-1998	Carim et al.	
	176	5,752,914	05-19-1998	Delonzor et al.	
	177	5,746,697	05-05-1998	Swedlow et al.	
	178	5,746,206	05-05-1998	Mannheimer	
	179	5,743,263	04-28-1998	Baker, Jr.	
	180	5,713,355	02-03-1998	Richardson et al.	
	181	5,697,371	12-16-1997	Aoyagi	
	182	5,692,503	12-02-1997	Kuentner	
	183	5,690,104	11-25-1997	Kanemoto, et al.	
	184	5,687,722	11-18-1997	Tien et al.	

Examiner Signature	Date Considered
*Examiner: Initial if reference considered, whether or not citation is in conformance with MPEP 609. Draw line through citation if not in conformance and not considered. Include copy of this form with next communication to applicant.	

T¹ - Place a check mark in this area when an English language Translation is attached.

INFORMATION DISCLOSURE STATEMENT BY APPLICANT	Application No.	11/366,209
	Filing Date	March 1, 2006
	First Named Inventor	Ammar Al-Ali et al.
	Art Unit	3735
<i>(Multiple sheets used when necessary)</i>		Examiner
SHEET 8 OF 13		Attorney Docket No. MLR.004A

U.S. PATENT DOCUMENTS					
Examiner Initials	Cite No.	Document Number Number - Kind Code (if known) Example: 1,234,567 B1	Publication Date MM-DD-YYYY	Name of Patentee or Applicant	Pages, Columns, Lines Where Relevant Passages or Relevant Figures Appear
	185	5,687,719	11-18-1997	Sato, et al.	
	186	5,685,301	11-11-1997	Klomhaus	
	187	5,678,544	10-21-1997	Delonzor et al.	
	188	5,676,141	10-14-1997	Hollub	
	189	5,676,139	10-14-1997	Goldberger et al.	
	190	5,662,106	09-02-1997	Swedlow et al.	
	191	5,660,567	08-26-1997	Nierlich et al.	
	192	5,645,060	07-08-1997	Yorkey	
	193	5,630,413	05-20-1997	Thomas et al.	
	194	5,603,623	02-18-1997	Nishikawa et al.	
	195	5,596,992	01-28-1997	Haaland et al.	
	196	5,595,176	01-21-1997	Yamaura	
	197	5,590,652	01-07-1997	Inai	
	198	5,588,427	12-31-1996	Tien	
	199	5,584,299	12-17-1996	Sakai et al.	
	200	5,577,500	11-26-1996	Potratz	
	201	5,555,882	09-17-1996	Richardson et al.	
	202	5,553,615	09-10-1996	Carim, et al.	
	203	5,551,423	09-03-1996	Sugiura	
	204	5,533,507	07-09-1996	Potratz	
	205	5,520,177	05-28-1996	Ogawa	
	206	5,503,148	04-02-1996	Pologe et al.	
	207	5,494,032	02-27-1996	Robinson et al.	
	208	5,490,523	02-13-1996	Isacson et al.	
	209	5,435,309	07-25-1995	Thomas et al.	
	210	5,429,128	07-04-1995	Cadell et al.	
	211	5,427,093	06-27-1995	Ogawa et al.	

Examiner Signature	Date Considered
<p>*Examiner: Initial if reference considered, whether or not citation is in conformance with MPEP 609. Draw line through citation if not in conformance and not considered. Include copy of this form with next communication to applicant.</p>	

T¹ - Place a check mark in this area when an English language Translation is attached.

INFORMATION DISCLOSURE STATEMENT BY APPLICANT	Application No.	11/366,209
	Filing Date	March 1, 2006
	First Named Inventor	Ammar Al-Ali et al.
	Art Unit	3735
<i>(Multiple sheets used when necessary)</i>		Examiner
SHEET 9 OF 13		Attorney Docket No. MLR.004A

U.S. PATENT DOCUMENTS					
Examiner Initials	Cite No.	Document Number <i>Number - Kind Code (if known)</i> Example: 1,234,567 B1	Publication Date MM-DD-YYYY	Name of Patentee or Applicant	Pages, Columns, Lines Where Relevant Passages or Relevant Figures Appear
	212	5,421,329	06-06-1995	Casciani et al.	
	213	5,413,101	05-09-1995	Sugiura	
	214	5,392,777	02-28-1995	Swedlow et al.	
	215	5,387,122	02-07-1995	Goldberger et al.	
	216	5,385,143	01-31-1995	Aoyagi	
	217	5,368,224	11-29-1994	Richardson et al.	
	218	5,361,758	11-08-1994	Hall et al.	
	219	5,355,882	10-18-1994	Ukawa et al.	
	220	5,355,880	10-18-1994	Thomas et al.	
	221	5,351,685	10-04-1994	Potratz	
	222	5,348,004	09-20-1994	Hollub	
	223	5,335,659	08-09-1994	Pologe et al.	
	224	5,313,940	5-24-1994	Fuse et al.	
	225	5,297,548	03-29-1994	Pologe	
	226	5,278,627	01-11-1994	Aoyagi	
	227	5,267,563	12-07-1993	Swedlow et al.	
	228	5,267,562	12-07-1993	Ukawa et al.	
	229	5,209,230	05-11-1993	Swedlow et al.	
	230	5,190,040	03-02-1993	Aoyagi	
	231	5,078,136	01-07-1992	Stone et al.	
	232	5,054,495	10-08-1991	Uemura, et al.	
	233	5,033,472	07-23-1991	Sato, et al.	
	234	4,997,769	03-05-1991	Lundsgaard	
	235	4,975,581	12-04-1990	Robinson et al.	
	236	4,967,571	11-06-1990	Sporri	
	237	4,964,010	10-16-1990	Miyasaka et al.	

Examiner Signature	Date Considered
<p>*Examiner: Initial if reference considered, whether or not citation is in conformance with MPEP 609. Draw line through citation if not in conformance and not considered. Include copy of this form with next communication to applicant.</p>	

T¹ - Place a check mark in this area when an English language Translation is attached.

INFORMATION DISCLOSURE STATEMENT BY APPLICANT	Application No.	11/366,209
	Filing Date	March 1, 2006
	First Named Inventor	Ammar Al-Ali et al.
	Art Unit	3735
<i>(Multiple sheets used when necessary)</i>	Examiner	
SHEET 10 OF 13	Attorney Docket No.	MLR.004A

U.S. PATENT DOCUMENTS					
Examiner Initials	Cite No.	Document Number Number - Kind Code (if known) Example: 1,234,567 B1	Publication Date MM-DD-YYYY	Name of Patentee or Applicant	Pages, Columns, Lines Where Relevant Passages or Relevant Figures Appear
	238	4,960,126	10-02-1990	Conlon et al.	
	239	4,955,379	09-11-1990	Hall	
	240	4,942,877	07-24-1990	Sakai et al.	
	241	4,934,372	06-19-1990	Corenman et al.	
	242	4,911,167	03-27-1990	Corenman et al.	
	243	4,869,254	09-26-1989	Stone et al.	
	244	4,867,571	09-19-1989	Frick et al.	
	245	4,863,265	09-05-1989	Flower, et al.	
	246	4,846,183	07-11-1989	Martin	
	247	4,832,484	05-23-1989	Aoyagi, et al.	
	248	4,800,885	01-31-1989	Johnson	
	249	4,781,195	11-01-1988	Martin	
	250	4,773,422	09-27-1988	Isaacson et al.	
	251	4,770,179	09-13-1988	New et al.	
	252	4,714,341	12-22-1987	Hamaguri et al.	
	253	4,700,708	10-20-1987	New et al.	
	254	4,694,833	09-22-1987	Hamaguri	
	255	4,685,464	08-11-1987	Goldberger	
	256	4,653,498	03-31-1987	New et al.	
	257	4,621,643	11-11-1986	New et al.	
	258	4,586,513	05-06-1986	Hamaguri	
	259	4,446,871	05-08-1984	Imura	
	260	4,266,554	05-12-1981	Hamaguri	
	261	4,167,331	09-11-1979	Nielsen	
	262	4,157,708	06-12-1979	Imura	
	263	3,998,550	12-21-1976	Konishi, et al.	

Examiner Signature	Date Considered
*Examiner: Initial if reference considered, whether or not citation is in conformance with MPEP 609. Draw line through citation if not in conformance and not considered. Include copy of this form with next communication to applicant.	

T¹ - Place a check mark in this area when an English language Translation is attached.

INFORMATION DISCLOSURE STATEMENT BY APPLICANT	Application No.	11/366,209
	Filing Date	March 1, 2006
	First Named Inventor	Ammar Al-Ali et al.
	Art Unit	3735
<i>(Multiple sheets used when necessary)</i>	Examiner	
SHEET 11 OF 13	Attorney Docket No.	MLR.004A

U.S. PATENT DOCUMENTS					
Examiner Initials	Cite No.	Document Number Number - Kind Code (if known) Example: 1,234,567 B1	Publication Date MM-DD-YYYY	Name of Patentee or Applicant	Pages, Columns, Lines Where Relevant Passages or Relevant Figures Appear
	264	RE35,122	12-19-1995	Corenman et al.	
	265	2004/0006261	01-08-2004	Swedlow et al.	
	266	2006/0030764	02-09-2006	Porges et al.	
	267	2004/0033618	02-19-2004	Haass, et al.	
	268	2002/0038078	03-28-2002	Ito	
	269	2005/0043902	02-24-2005	Haaland et al.	
	270	2005/0049469	03-03-2005	Aoyagi et al.	
	271	2002/0059047	05-16-2002	Haaland	
	272	2004/0064259	04-01-2004	Haaland et al.	
	273	2005/0070773	03-31-2005	Chin et al.	
	274	2005/0070775	03-31-2005	Chin et al.	
	275	2005/0075546	04-07-2005	Samsoondar et al.	
	276	2005/0085735	04/21-2005	Baker JR. et al.	
	277	2004/0092805	05-13-2004	Yarita	
	278	2003/0109775	06-12-2003	O'Neil, et al.	
	279	2002/0111748	08-15-2002	Kobayashi et al.	
	280	2003/0120160	06-26-2003	Yarita	
	281	2005/0124871	06/09-2005	Baker JR. et al.	
	282	2004/0138538	07-15-2004	Stetson	
	283	2004/0138540	07-15-2004	Baker JR. et al.	
	284	2003/0139657	07-24-2003	Solenberger	
	285	2005/143634	06-30-2005	Baker JR. et al.	
	286	2005/0143943	06-30-2005	Brown	
	287	2005/0148834	07-07-2005	Hull, et al.	
	288	2004/0158135	08-12-2004	Baker JR. et al.	
	289	2004/0162472	08-19-2004	Berson et al.	
	290	2004/0167382	08-26-2004	Gardner, et al.	

Examiner Signature	Date Considered
<p>*Examiner: Initial if reference considered, whether or not citation is in conformance with MPEP 609. Draw line through citation if not in conformance and not considered. Include copy of this form with next communication to applicant.</p>	

T¹ - Place a check mark in this area when an English language Translation is attached.

INFORMATION DISCLOSURE STATEMENT BY APPLICANT	Application No.	11/366,209
	Filing Date	March 1, 2006
	First Named Inventor	Ammar Al-Ali et al.
	Art Unit	3735
<i>(Multiple sheets used when necessary)</i>		Examiner
SHEET 12 OF 13		Attorney Docket No. MLR.004A

U.S. PATENT DOCUMENTS					
Examiner Initials	Cite No.	Document Number Number - Kind Code (if known) Example: 1,234,567 B1	Publication Date MM-DD-YYYY	Name of Patentee or Applicant	Pages, Columns, Lines Where Relevant Passages or Relevant Figures Appear
	291	2004/0167382	08-26-2004	Gardner et al.	
	292	2004/0176670	09-09-2004	Takamura et al.	
	293	2004/0181134	09-16-2004	Baker JR. et al.	
	294	2005/0184895	08-25-2005	Petersen et al.	
	295	2005/0187447	08-25-2005	Chew et al.	
	296	2005/0187448	08-25-2005	Petersen et al.	
	297	2005/0187449	08-25-2005	Chew et al.	
	298	2005/0187450	08-25-2005	Chew et al.	
	299	2005/0187452	08-25-2005	Petersen et al.	
	300	2005/0187453	08-25-2005	Petersen et al.	
	301	2003/0195402	10-16-2003	Fein et al.	
	302	2005/0197549	09-08-2005	Baker JR.	
	303	2005/0197579	09-08-2005	Baker JR.	
	304	2005/0197793	09-08-2005	Baker JR.	
	305	2004/0199063	10-07-2004	O'Neil et al.	
	306	2005/0203357	09-15-2005	Debreczeny et al.	
	307	2004/0204639	10-14-2004	Casciani et al.	
	308	2004/0204868	10-14-2004	Maynard, et al.	
	309	2005/0228253	10-13-2005	Debreczeny	
	310	2005/0250997	11-10-2005	Takedo et al.	
	311	2004/0267140	12-30-2004	Ito et al.	
	312	RE36,000	12-22-1998	Swedlow et al.	
	313	RE33,643	07-23-1991	Isacson et al.	

FOREIGN PATENT DOCUMENTS						
Examiner Initials	Cite No.	Foreign Patent Document Country Code-Number-Kind Code Example: JP 1234567	Publication Date MM-DD-YYYY	Name of Patentee or Applicant	Pages, Columns, Lines Where Relevant Passages or Relevant Figures Appear	T ¹
	314					
	315					

Examiner Signature	Date Considered
*Examiner: Initial if reference considered, whether or not citation is in conformance with MPEP 609. Draw line through citation if not in conformance and not considered. Include copy of this form with next communication to applicant.	

T¹ - Place a check mark in this area when an English language Translation is attached.

INFORMATION DISCLOSURE STATEMENT BY APPLICANT	Application No.	11/366,209
	Filing Date	March 1, 2006
	First Named Inventor	Ammar Al-Ali et al.
	Art Unit	3735
<i>(Multiple sheets used when necessary)</i>		Examiner
SHEET 13 OF 13		Attorney Docket No. MLR.004A

FOREIGN PATENT DOCUMENTS						
Examiner Initials	Cite No.	Foreign Patent Document <i>Country Code-Number-Kind Code</i> Example: JP 1234567	Publication Date MM-DD-YYYY	Name of Patentee or Applicant	Pages, Columns, Lines Where Relevant Passages or Relevant Figures Appear	T ¹
	316					
	317					
	318					

NON PATENT LITERATURE DOCUMENTS			
Examiner Initials	Cite No.	Include name of the author (in CAPITAL LETTERS), title of the article (when appropriate), title of the item (book, magazine, journal, serial, symposium, catalog, etc.), date, page(s), volume-issue number(s), publisher, city and/or country where published.	T ¹
	319		
	320		
	321		
	322		
	323		

2695860
061906

Examiner Signature	Date Considered
<p>*Examiner: Initial if reference considered, whether or not citation is in conformance with MPEP 609. Draw line through citation if not in conformance and not considered. Include copy of this form with next communication to applicant.</p>	

T¹ - Place a check mark in this area when an English language Translation is attached.

**INFORMATION DISCLOSURE
STATEMENT BY APPLICANT**

(Multiple sheets used when necessary)

SHEET 1 OF 6

Application No.	11/366,209
Filing Date	March 1, 2006
First Named Inventor	Ammar Al-Ali
Art Unit	3735
Examiner	
Attorney Docket No.	MLR.004A

U.S. PATENT DOCUMENTS

Examiner Initials	Cite No.	Document Number Number - Kind Code (if known) Example: 1,234,567 B1	Publication Date MM-DD-YYYY	Name of Patentee or Applicant	Pages, Columns, Lines Where Relevant Passages or Relevant Figures Appear
	1	7,044,918	05/2006	Diab	
	2	7,041,060	05/2006	Flaherty, et al	
	3	7,039,449	05/2006	Al-Ali	
	4	7,030,749	04/2006	Al-Ali	
	5	7,027,849	04/2006	Al-Ali	
	6	7,024,233	04/2006	Al, et al.	
	7	7,015,451	02/2006	Dalke, et al.	
	8	7,003,339	02/2006	Diab, et al.	
	9	7,003,338	02/2006	Weber, et al.	
	10	6,999,904	02/2006	Weber, et al.	
	11	6,996,427	02/2006	Ali, et al.	
	12	6,993,371	01/2006	Kiani, et al.	
	13	6,985,764	01/2006	Mason, et al.	
	14	6,979,812	12/2005	Al-Ali	
	15	6,970,792	11/2005	Diab	
	16	6,961,598	11/2005	Diab	
	17	6,950,687	09/2005	Al-Ali	
	18	6,943,348	09/2005	Coffin, IV	
	19	6,939,305	09/2005	Flaherty, et al.	
	20	6,934,570	08/2005	Kiani, et al.	
	21	6,931,268	08/2005	Kiani-Azarbayjany, et al.	
	22	6,920,345	07/2005	Al-Ali, et al.	
	23	6,898,452	05/2005	Al-Ali, et al.	
	24	6,861,639	03/2005	Al-Ali	
	25	6,852,083	02/2005	Caro, et al.	
	26	6,850,788	02/2005	Al-Ali	
	27	6,850,787	02/2005	Weber, et al.	
	28	6,830,711	12/2004	Mills, et al.	
	29	6,826,419	11/2004	Diab, et al.	

Examiner Signature

Date Considered

*Examiner: Initial if reference considered, whether or not citation is in conformance with MPEP 609. Draw line through citation if not in conformance and not considered. Include copy of this form with next communication to applicant.

T¹ - Place a check mark in this area when an English language Translation is attached.

INFORMATION DISCLOSURE STATEMENT BY APPLICANT	Application No.	11/366,209
	Filing Date	March 1, 2006
	First Named Inventor	Ammar Al-Ali
	Art Unit	3735
<i>(Multiple sheets used when necessary)</i>		Examiner
SHEET 2 OF 6		Attorney Docket No. MLR.004A

U.S. PATENT DOCUMENTS					
Examiner Initials	Cite No.	Document Number <i>Number - Kind Code (if known)</i> Example: 1,234,567 B1	Publication Date MM-DD-YYYY	Name of Patentee or Applicant	Pages, Columns, Lines Where Relevant Passages or Relevant Figures Appear
	30	6,822,564	11/2004	Al-Ali	
	31	6,816,741	11/2004	Diab	
	32	6,813,511	11/2004	Diab, et al.	
	33	6,792,300	09/2004	Diab, et al.	
	34	6,771,994	08/2004	Kiani, et al.	
	35	6,770,028	08/2004	Ali, et al.	
	36	6,760,607	07/2004	Al-Ali	
	37	6,745,060	06/2004	Diab, et al.	
	38	6,735,459	05/2004	Parker	
	39	6,725,075	04/2004	Al-Ali	
	40	6,721,585	04/2004	Parker	
	41	RE38,492	04/2004	Diab, et al.	
	42	6,714,804	03/2004	Al-Ali, et al.	
	43	RE38,476	03/2004	Diab, et al.	
	44	6,699,194	03/2004	Diab, et al.	
	45	6,697,658	02/2004	Al-Ali	
	46	6,697,656	02/2004	Al-Ali	
	47	6,684,091	01/2004	Parker	
	48	6,684,090	01/2004	Ali, et al.	
	49	6,678,543	01/2004	Diab, et al.	
	50	6,671,531	12/2003	Al-Ali, et al.	
	51	6,661,161	12/2003	Lanzo, et al.	
	52	6,658,276	12/2003	Diab, et al.	
	53	6,654,624	11/2003	Diab, et al.	
	54	6,650,917	11/2003	Diab, et al.	
	55	6,643,530	11/2003	Diab, et al.	
	56	6,640,116	10/2003	Diab	
	57	6,632,181	10/2003	Flaherty, et al.	
	58	6,606,511	08/2003	Ali, et al.	

Examiner Signature	Date Considered
*Examiner: Initial if reference considered, whether or not citation is in conformance with MPEP 609. Draw line through citation if not in conformance and not considered. Include copy of this form with next communication to applicant.	

T¹ - Place a check mark in this area when an English language Translation is attached.

INFORMATION DISCLOSURE STATEMENT BY APPLICANT	Application No.	11/366,209
	Filing Date	March 1, 2006
	First Named Inventor	Ammar Al-Ali
	Art Unit	3735
<i>(Multiple sheets used when necessary)</i>		Examiner
SHEET 3 OF 6		Attorney Docket No. MLR.004A

U.S. PATENT DOCUMENTS					
Examiner Initials	Cite No.	Document Number Number - Kind Code (if known) Example: 1,234,567 B1	Publication Date MM-DD-YYYY	Name of Patentee or Applicant	Pages, Columns, Lines Where Relevant Passages or Relevant Figures Appear
	59	6,597,933	07/2003	Kiani, et al.	
	60	6,595,316	07/2003	Cybulski, et al.	
	61	6,584,336	06/2003	Ali, et al.	
	62	6,580,086	06/2003	Schulz, et al.	
	63	6,542,764	04/2003	Al-Ali, et al.	
	64	6,541,756	04/2003	Schulz, et al.	
	65	6,526,300	02/2003	Kiani, et al.	
	66	6,525,386	02/2003	Mills, et al.	
	67	6,519,487	02/2003	Parker	
	68	6,515,273	02/2003	Al-Ali	
	69	6,501,975	12/2002	Diab, et al.	
	70	6,470,199	10/2002	Kopotic, et al.	
	71	6,463,311	10/2002	Diab	
	72	6,430,525	08/2002	Weber, et al.	
	73	6,397,091	05/2002	Diab, et al.	
	74	6,388,240	05/2002	Schulz, et al.	
	75	6,377,829	04/2002	Al-Ali	
	76	6,371,921	04/2002	Caro, et al.	
	77	6,360,114	03/2002	Diab, et al.	
	78	6,349,228	02/2002	Kiani, et al.	
	79	6,343,224	01/2002	Parker	
	80	6,334,065	12/2001	Al-Ali, et al.	
	81	6,321,100	11/2001	Parker	
	82	6,285,896	09/2001	Tobler, et al.	
	83	6,280,213	08/2001	Tobler, et al.	
	84	6,278,522	08/2001	Lepper, Jr., et al.	
	85	6,263,222	07/2001	Diab, et al.	
	86	6,256,523	07/2001	Diab, et al.	
	87	6,236,872	05/2001	Diab, et al.	

Examiner Signature	Date Considered
<p>*Examiner: Initial if reference considered, whether or not citation is in conformance with MPEP 609. Draw line through citation if not in conformance and not considered. Include copy of this form with next communication to applicant.</p>	

T¹ - Place a check mark in this area when an English language Translation is attached.

INFORMATION DISCLOSURE STATEMENT BY APPLICANT	Application No.	11/366,209
	Filing Date	March 1, 2006
	First Named Inventor	Ammar Al-Ali
	Art Unit	3735
<i>(Multiple sheets used when necessary)</i>		Examiner
SHEET 4 OF 6		Attorney Docket No. MLR.004A

U.S. PATENT DOCUMENTS					
Examiner Initials	Cite No.	Document Number <i>Number - Kind Code (if known)</i> Example: 1,234,567 B1	Publication Date MM-DD-YYYY	Name of Patentee or Applicant	Pages, Columns, Lines Where Relevant Passages or Relevant Figures Appear
	88	6,229,856	05/2001	Diab, et al.	
	89	6,206,830	03/2001	Diab, et al.	
	90	6,184,521	02/2001	Coffin, IV, et al.	
	91	6,165,005	12/2000	Mills, et al.	
	92	6,157,850	12/2000	Diab, et al.	
	93	6,152,754	11/2000	Gerhardt, et al.	
	94	6,151,516	11/2000	Kiani-Azarbayjany, et al.	
	95	6,144,868	11/2000	Parker	
	96	6,110,522	08/2000	Lepper, Jr., et al.	
	97	6,088,607	07/2000	Diab, et al.	
	98	6,081,735	06/2000	Diab, et al.	
	99	6,067,462	05/2000	Diab, et al.	
	100	6,045,509	04/2000	Caro, et al.	
	101	6,036,642	03/2000	Diab, et al.	
	102	6,027,452	02/2000	Flaherty, et al.	
	103	6,011,986	01/2000	Diab, et al.	
	104	6,002,952	12/1999	Diab, et al.	
	105	5,997,343	12/1999	Mills, et al.	
	106	5,995,855	11/1999	Kiani, et al.	
	107	5,940,182	08/1999	Lepper, Jr., et al.	
	108	5,934,925	08/1999	Tobler, et al.	
	109	5,919,134	07/1999	Diab	
	110	5,904,654	05/1999	Wohlmann, et al.	
	111	5,890,929	04/1999	Mills, et al.	
	112	5,860,919	01/1999	Kiani-Azarbayjany, et al.	
	113	5,833,618	11/1998	Caro, et al.	
	114	5,830,131	11/1998	Caro, et al.	
	115	5,823,950	10/1998	Diab, et al.	
	116	5,810,734	09/1998	Caro, et al.	

Examiner Signature	Date Considered
*Examiner: Initial if reference considered, whether or not citation is in conformance with MPEP 609. Draw line through citation if not in conformance and not considered. Include copy of this form with next communication to applicant.	

T¹ - Place a check mark in this area when an English language Translation is attached.

INFORMATION DISCLOSURE STATEMENT BY APPLICANT	Application No.	11/366,209
	Filing Date	March 1, 2006
	First Named Inventor	Ammar Al-Ali
	Art Unit	3735
<i>(Multiple sheets used when necessary)</i>		Examiner
SHEET 5 OF 6		Attorney Docket No. MLR.004A

U.S. PATENT DOCUMENTS					
Examiner Initials	Cite No.	Document Number Number - Kind Code (if known) Example: 1,234,567 B1	Publication Date MM-DD-YYYY	Name of Patentee or Applicant	Pages, Columns, Lines Where Relevant Passages or Relevant Figures Appear
	117	5,791,347	08/1998	Flaherty, et al.	
	118	5,785,659	07/1998	Caro, et al.	
	119	5,782,757	07/1998	Diab, et al.	
	120	5,769,785	06/1998	Diab, et al.	
	121	5,760,910	06/1998	Lepper, Jr., et al.	
	122	5,758,644	06/1998	Diab, et al.	
	123	5,743,262	04/1998	Lepper, Jr., et al.	
	124	Des. 393,830	04/1998	Tobler, et al.	
	125	5,685,299	11/1997	Diab, et al.	
	126	5,645,440	07/1997	Tobler, et al.	
	127	5,638,818	06/1997	Diab, et al.	
	128	5,638,816	06/1997	Kiani-Azarbayjany, et al.	
	129	5,632,272	05/1997	Diab, et al.	
	130	5,602,924	02/1997	Durand, et al.	
	131	5,590,649	01/1997	Caro, et al.	
	132	5,562,002	10/1986	Lalin	
	133	5,533,511	07/1996	Kaspari, et al.	
	134	5,494,043	02/1996	O'Sullivan, et al.	
	135	5,490,505	02/1996	Diab, et al.	
	136	5,482,036	01/1996	Diab, et al.	
	137	D363,120	10/1995	Savage, et al.	
	138	5,452,717	09/1995	Branigan, et al.	
	139	D362,063	09/1995	Savage, et al.	
	140	D361,840	08/1995	Savage, et al.	
	141	5,431,170	07/1995	Mathews	
	142	D353,196	12/1994	Savage, et al.	
	143	D353,195	12/1994	Savage, et al.	
	144	5,337,744	08/1994	Branigan	
	145	5,163,438	11/1992	Gordon, et al.	

Examiner Signature	Date Considered
*Examiner: Initial if reference considered, whether or not citation is in conformance with MPEP 609. Draw line through citation if not in conformance and not considered. Include copy of this form with next communication to applicant.	

T¹ - Place a check mark in this area when an English language Translation is attached.

INFORMATION DISCLOSURE STATEMENT BY APPLICANT	Application No.	11/366,209
	Filing Date	March 1, 2006
	First Named Inventor	Ammar Al-Ali
	Art Unit	3735
<i>(Multiple sheets used when necessary)</i>		Examiner
SHEET 6 OF 6		Attorney Docket No. MLR.004A

U.S. PATENT DOCUMENTS					
Examiner Initials	Cite No.	Document Number <i>Number - Kind Code (if known)</i> Example: 1,234,567 B1	Publication Date MM-DD-YYYY	Name of Patentee or Applicant	Pages, Columns, Lines Where Relevant Passages or Relevant Figures Appear
	146	5,069,213	12/1991	Polczynski	
	147	5,041,187	08/1991	Hink, et al.	
	148	4,964,408	10/1990	Hink, et al.	
	149	4,960,128	10/1990	Gordon, et al.	

2695867
061906

Examiner Signature	Date Considered
<p>*Examiner: Initial if reference considered, whether or not citation is in conformance with MPEP 609. Draw line through citation if not in conformance and not considered. Include copy of this form with next communication to applicant.</p>	

T¹ - Place a check mark in this area when an English language Translation is attached.

Law



UNITED STATES PATENT AND TRADEMARK OFFICE

UNITED STATES DEPARTMENT OF COMMERCE
 United States Patent and Trademark Office
 Address: COMMISSIONER FOR PATENTS
 P.O. Box 1450
 Alexandria, Virginia 22313-1450
 www.uspto.gov

APPLICATION NUMBER	FILING OR 371 (c) DATE	FIRST NAMED APPLICANT	ATTORNEY DOCKET NUMBER
11/366,209	03/01/2006	Ammar Al-Ali	MLR.004A

20995
 KNOBBE MARTENS OLSON & BEAR LLP
 2040 MAIN STREET
 FOURTEENTH FLOOR
 IRVINE, CA 92614



**CONFIRMATION NO. 2025
 FORMALITIES
 LETTER**

Date Mailed: 04/07/2006

NOTICE TO FILE MISSING PARTS OF NONPROVISIONAL APPLICATION

06/01/2006 HTECKLU1 00000016 11366209

FILED UNDER 37 CFR 1.53(b)

01 FC:1011	300.00 DP
02 FC:1111	500.00 DP
03 FC:1311	200.00 DP
04 FC:1201	200.00 DP
05 FC:1051	130.00 DP

Filing Date Granted

Items Required To Avoid Abandonment:

An application number and filing date have been accorded to this application. The item(s) indicated below, however, are missing. Applicant is given **TWO MONTHS** from the date of this Notice within which to file all required items and pay any fees required below to avoid abandonment. Extensions of time may be obtained by filing a petition accompanied by the extension fee under the provisions of 37 CFR 1.136(a).

- The statutory basic filing fee is missing.
Applicant must submit \$ 300 to complete the basic filing fee for a non-small entity. If appropriate, applicant may make a written assertion of entitlement to small entity status and pay the small entity filing fee (37 CFR 1.27).
- The oath or declaration is missing. A properly signed oath or declaration in compliance with 37 CFR 1.63, identifying the application by the above Application Number and Filing Date, is required.
Note: If a petition under 37 CFR 1.47 is being filed, an oath or declaration in compliance with 37 CFR 1.63 signed by all available joint inventors, or if no inventor is available by a party with sufficient proprietary interest, is required.

The applicant needs to satisfy supplemental fees problems indicated below.

The required item(s) identified below must be timely submitted to avoid abandonment:

- Additional claim fees of \$200 as a non-small entity, including any required multiple dependent claim fee, are required. Applicant must submit the additional claim fees or cancel the additional claims for which fees are due.
- To avoid abandonment, a surcharge (for late submission of filing fee, search fee, examination fee or oath or declaration) as set forth in 37 CFR 1.16(f) of \$130 for a non-small entity, must be submitted with the missing items identified in this letter.

SUMMARY OF FEES DUE:

Total additional fee(s) required for this application is \$1330 for a Large Entity

- \$300 Statutory basic filing fee.
- \$130 Surcharge.

- The application search fee has not been paid. Applicant must submit \$500 to complete the search fee.
- The application examination fee has not been paid. Applicant must submit \$200 to complete the examination fee for a large entity

- Total additional claim fee(s) for this application is \$200
 - \$200 for 1 independent claims over 3.

Replies should be mailed to: Mail Stop Missing Parts
Commissioner for Patents
P.O. Box 1450
Alexandria VA 22313-1450

A copy of this notice MUST be returned with the reply.

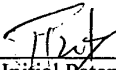
Office of Initial Patent Examination (571) 272-4000, or 1-800-PTO-9199, or 1-800-972-6382
PART 2 - COPY TO BE RETURNED WITH RESPONSE



**TRANSMITTAL LETTER
RESPONSE TO MISSING PARTS**

Applicant : Ammar Al-Ali et al.
App. No : 11/366,209
Filed : March 1, 2006
For : MULTIPLE WAVELENGTH SENSOR
SUBSTRATE
Art Unit : Unknown

CERTIFICATE OF MAILING

I hereby certify that this correspondence and all marked attachments are being deposited with the United States Postal Service as first-class mail in an envelope addressed to: Commissioner for Patents, P.O. Box 1450, Alexandria, VA 22313-1450, on

May 26, 2006

(Date)

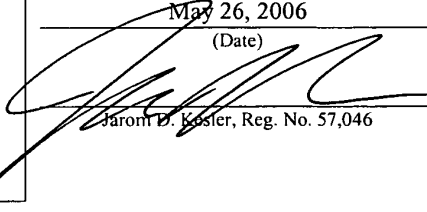
Jarom D. Koster, Reg. No. 57,046

**Mail Stop Missing Parts
Commissioner for Patents
P.O. Box 1450
Alexandria, VA 22313-1450**

Dear Sir:

In response to the Notice to File Missing Parts of Application Under 37 CFR 1.53(f), which was mailed by the Office on April 7, 2006, enclosed are:

- (X) A Declaration in 3 pages.
- (X) Statement Under 37 CFR 3.73(b) Power of Attorney and copy of Assignment.
- (X) A Notice to File Missing Parts.
- (X) Return prepaid postcard.

PATENT

Case Docket No. MLR.004A

Date: May 26, 2006

The fee has been calculated as shown below:

FEE CALCULATION				
FEE TYPE		FEE CODE	CALCULATION	TOTAL
Basic Utility	<i>1.16(a)(1)</i>	1011 (\$300)		\$300
Search Fee	<i>1.16(k)</i>	1111 (\$500)		\$500
Examination Fee	<i>1.16(o)</i>	1311 (\$200)		\$200
Excess Claims > 20	15 - 20 = 0	1202 (\$50)	0 x 50 =	\$0
Independent > 3	4 - 3 = 1	1201 (\$200)	1 x 200 =	\$200
Multiple Claim	<i>1.16(j)</i>	1203 (\$360)		\$0
Application Size Fee	84 - 100 = 0	1081 (\$250) ⁺	0 x 250 =	\$0
Recordation Fee	<i>1.21(h)</i>	8021 (\$40)	0 x 40 =	\$0
Non-English Spec.	<i>1.17(i)</i>	1053 (\$130)		\$0
Surcharge	<i>1.16(f)</i>	1051 (\$130)		\$130
			TOTAL FEE DUE	\$1,330

(X) A check in the amount of \$1,330 to cover the above fees is enclosed.

The Commissioner is hereby authorized to charge any additional fees which may be required, now or in the future, or credit any overpayment, to Account No. 11-1410.

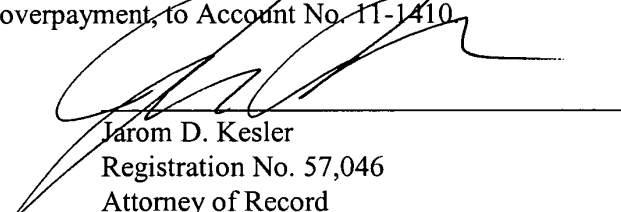

 Jarom D. Kesler
 Registration No. 57,046
 Attorney of Record
 Customer No. 20,995
 (949) 760-0404

2628159
 052406

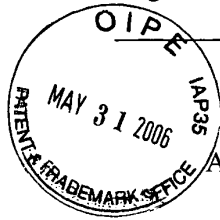

DECLARATION - USA PATENT APPLICATION

As a below named inventor, I hereby declare that:

My residence, mailing address and citizenship are as stated below next to my name;

I believe I am an original, first and joint inventor of the subject matter which is claimed and for which a patent is sought on the invention entitled MULTIPLE WAVELENGTH SENSOR SUBSTRATE; the specification of which was filed on March 1, 2006 as Application Serial No. 11/366,209.

I hereby state that I have reviewed and understand the contents of the above identified specification, including the claims, as amended by any amendment referred to above;

I acknowledge the duty to disclose information which is material to patentability as defined in Title 37, Code of Federal Regulations, § 1.56;

I hereby claim the benefit under Title 35, United States Codes § 119(e) of any United States provisional application(s) listed below.

Application No.: 60/657,596	Filing Date: March 1, 2005
Application No.: 60/657,281	Filing Date: March 1, 2005
Application No.: 60/657,268	Filing Date: March 1, 2005
Application No.: 60/657,759	Filing Date: March 1, 2005

I hereby claim the benefit under Title 35, United States Code, § 120 of any United States application(s) listed below, and insofar as the subject matter of each of the claims of this application is not disclosed in the prior United States application in the manner provided by the first paragraph of Title 35, United States Code § 112, I acknowledge the duty to disclose information which is material to patentability as defined in Title 37, Code of Federal Regulations, § 1.56, which became available between the filing date of the prior application and the national or PCT international filing date of this application:

I hereby declare that all statements made herein of my own knowledge are true and that all statements made on information and belief are believed to be true; and further that these statements were made with the knowledge that willful false statements and the like so made are punishable by fine or imprisonment, or both, under Section 1001 of Title 18 of the United States Code and that such willful, false statements may jeopardize the validity of the application or any patent issued thereon.

Full name of first inventor: Ammar Al-Ali

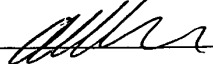
Inventor's signature 

Date 5/22/06

Residence: 10880 Phillips Street, Tustin, CA 92782

Citizenship: United States

Mailing Address: Same as above

Full name of second inventor: Mohamed Diab

Inventor's signature 

Date 5/22/06

Residence: 25075 White Spring, Mission Viejo, CA 92692

Citizenship: United States

Mailing Address: Same as above

Full name of third inventor: Marcelo Lamego

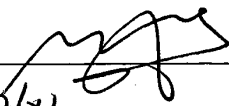
Inventor's signature 

Date 5/22/06

Residence: ~~524 Cardiff, Irvine, CA 92606~~

Citizenship: ~~United States~~ BRAZIL

55 CALLE ALAMITOS
RANCHO SANTA MARGARITA
CA 92688

Mailing Address: Same as above

Full name of fourth inventor: James P. Coffin

Inventor's signature James P. Coffin

Date 23 May 06

Residence: 30 Hollyhock Lane, Mission Viejo, CA 92692

Citizenship: United States

Mailing Address: Same as above

Full name of fifth inventor: Yassir Abdul-Hafiz

Inventor's signature Yassir Abdul-Hafiz

Date 5/22/06

Residence: ~~20041 Osterman Road, #S7, Lake Forest, CA 92630~~
852 Las Palmas, Irvine, Ca 92602

Citizenship: United States

Mailing Address: Same as above

Send Correspondence To:
KNOBBE, MARTENS, OLSON & BEAR, LLP
Customer No. 20,995

2602322
051506



STATEMENT UNDER 37 CFR § 3.73(b)
and
CHANGE OF CORRESPONDENCE ADDRESS

Applicant	:	Ammar Al-Ali et al.
App. No.	:	11/366,209
Filed	:	March 1, 2006
For	:	MULTIPLE WAVELENGTH SENSOR SUBSTRATE
Examiner	:	Unknown
Group Art Unit	:	Unknown

Commissioner for Patents
P.O. Box 1450
Alexandria, VA 22313-1450

Dear Sir:

This document is being filed with a copy of a "Revocation and General Power of Attorney" signed by the Assignee and sets forth the chain of title of the above-identified application.

Please recognize or change the correspondence address for the above-identified application to **Customer No. 20,995**.

MASIMO LABORATORIES, INC., a Corporation, is the Assignee of the entire right, title, and interest of the above-referenced application by virtue of:

The attached copy of the Assignment being forwarded to the Recordation Branch concurrently under separate cover.

The undersigned is an agent of Customer Number 20995 and is authorized to act on behalf of the assignee as provided in the attached copy of the "Revocation and Power of Attorney." All correspondence is to be directed to **Customer No. 20,995**.

Respectfully submitted,
KNOBBE, MARTENS, OLSON & BEAR, LLP

Dated: 5/26/06

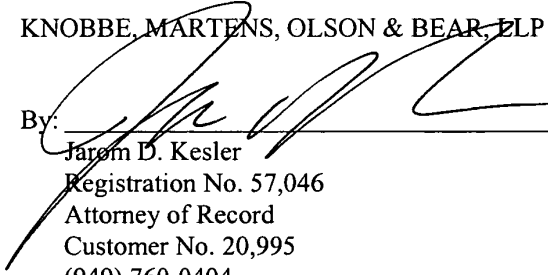
By: 
 Jarom D. Kesler
 Registration No. 57,046
 Attorney of Record
 Customer No. 20,995
 (949) 760-0404



**REVOCATION
AND
GENERAL POWER OF ATTORNEY**

Commissioner for Patents
P.O. Box 1450
Alexandria, VA 22313-1450

Dear Sir:

The undersigned is an empowered representative of the Assignee and hereby appoints the registrants of Knobbe, Martens, Olson & Bear, LLP, **Customer No. 20,995**, as attorneys and agents to represent the Assignee before the United States Patent and Trademark Office (USPTO) in connection with any and all patent applications assigned to the Assignee according to the USPTO assignment records or assignment documents supplied with an accompanying Statement Under 37 CFR § 3.73(b). This appointment is to be to the exclusion of the inventor(s) and his attorney(s) in accordance with the provisions of 37 CFR § 3.71.

All previous powers of attorney for the below named Assignee are hereby revoked.

A Statement Under 37 CFR § 3.73(b), signed by a registrant of Knobbe, Martens, Olson & Bear, LLP, is attached setting forth a full chain of title for the subject application owned by the Assignee named below.

Please recognize or change the correspondence address for the above-identified application to **Customer No. 20,995**.

By:  Date: 9-8-04

Name: Joe E. Kiani Title: President and CEO

Assignee: MASIMO LABORATORIES, INC.

Address: 40 Parker, Irvine, CA 92618

Application No.: 11/366,209
Filing Date: March 1, 2006

PATENT
Client Code: MLR.004A
Page 1

ASSIGNMENT

WHEREAS, We, Ammar Al-Ali, a United States citizen, residing at 10880 Phillips Street, Tustin, CA 92782; Mohamed Diab a United States citizen, residing at 25075 White Spring, Mission Viejo, CA 92692; Marcelo Lamego, a United States citizen, residing at 524 Cardiff, Irvine, CA 92606; James P. Coffin, a United States citizen, residing at 30 Hollyhock Lane, Mission Viejo, CA 92692; and Yassir Abdul-Hafiz, a United States citizen, residing at 20041 Osterman Road, #S7, Lake Forest, CA, 92630, have invented certain new and useful improvements in a MULTIPLE WAVELENGTH SENSOR SUBSTRATE for which we have filed an application for Letters Patent in the United States, Application No. 11/366,209, Filed on March 1, 2006;

AND WHEREAS, MASIMO LABORATORIES, INC. (hereinafter "ASSIGNEE"), a Corporation, with its principal place of business at 40 Parker, Irvine, CA 92618, desires to acquire the entire right, title, and interest in and to the said improvements and the said Application:

NOW, THEREFORE, in consideration of the sum of One Dollar (\$1.00) to me in hand paid, and other good and valuable consideration, the receipt of which is hereby acknowledged, we, the said inventors, do hereby acknowledge that we have sold, assigned, transferred and set over, and by these presents do hereby sell, assign, transfer and set over, unto the said ASSIGNEE, its successors, legal representatives and assigns, the entire right, title, and interest throughout the world in, to and under the said improvements, and the said application and all provisional applications relating thereto, and all divisions, renewals and continuations thereof, and all Letters Patent of the United States which may be granted thereon and all reissues and extensions thereof, and all rights of priority under International Conventions and applications for Letters Patent which may hereafter be filed for said improvements in any country or countries foreign to the United States, and all Letters Patent which may be granted for said improvements in any country or countries foreign to the United States and all extensions, renewals and reissues thereof; and we hereby authorize and request the Commissioner of Patents of the United States, and any Official of any country or countries foreign to the United States, whose duty it is to issue patents on applications as aforesaid, to issue all Letters Patent for said improvements to the said ASSIGNEE, its successors, legal representatives and assigns, in accordance with the terms of this instrument.

AND WE DO HEREBY sell, assign, transfer, and convey to ASSIGNEE, his successors, legal representatives, and assigns all claims for damages and all remedies arising out of any violation of the rights assigned hereby that may have accrued prior to the date of assignment to ASSIGNEE, or may accrue hereafter, including, but not limited to, the right to sue for, collect, and retain damages for past infringements of the said Letters Patent before or after issuance.

AND WE HEREBY covenant and agree that we will communicate to the said ASSIGNEE, its successors, legal representatives and assigns, any facts known to us respecting said improvements, and testify in any legal proceeding, sign all lawful papers, execute all divisional, continuing and reissue applications, make all rightful oaths and generally do everything possible to aid the said ASSIGNEE, its successors, legal representatives and assigns, to obtain and enforce proper patent protection for said improvements in all countries.

IN TESTIMONY WHEREOF, I hereunto set my hand and seal this 22 day of May, 2006

[Signature]
Ammar Al-Ali

STATE OF Ca. }
COUNTY OF Orange. } ss.

On 5.22.06, before me, Sasha z. Paez, personally appeared Ammar Al Ali personally known to me (or proved to me on the basis of satisfactory evidence) to be the person(s) whose name(s) is/are subscribed to the within instrument, and acknowledged to me that he executed the same in he authorized capacity(ies), and that by he signature(s) on the instrument the person(s), or the entity upon behalf of which the person(s) acted, executed the instrument.

WITNESS my hand and official seal.

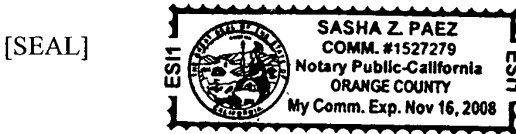

[Signature]
Notary Signature

IN TESTIMONY WHEREOF, I hereunto set my hand and seal this 22 day of May, 2006

[Signature]
Mohamed Diab

STATE OF Ca. }
COUNTY OF Orange } ss.

On 5-22-06, before me, Sasha z. Paez, personally appeared Mohamed Diab personally known to me (or proved to me on the basis of satisfactory evidence) to be the person(s) whose name(s) is/are subscribed to the within instrument, and acknowledged to me that he executed the same in his authorized capacity(ies), and that by his signature(s) on the instrument the person(s), or the entity upon behalf of which the person(s) acted, executed the instrument.

WITNESS my hand and official seal.

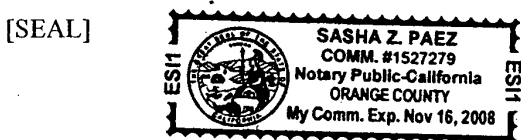

[Signature]
Notary Signature

IN TESTIMONY WHEREOF, I hereunto set my hand and seal this 22 day of May, 2006

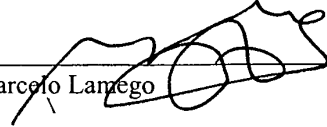
Marcelo Lamego

STATE OF Ca. }
COUNTY OF Orange } ss.

On 5-22-06, before me, Sasha Z. Paez, personally appeared Marcelo Lamego personally known to me (or proved to me on the basis of satisfactory evidence) to be the person(s) whose name(s) is/are subscribed to the within instrument, and acknowledged to me that he his executed the same in authorized capacity(ies), and that by signature(s) on the instrument the person(s), or the entity upon behalf of which the person(s) acted, executed the instrument.

WITNESS my hand and official seal.



Sasha Z. Paez
Notary Signature

IN TESTIMONY WHEREOF, I hereunto set my hand and seal this 22 day of May, 2006

James P. Coffin
James P. Coffin

STATE OF Ca }
COUNTY OF Orange } ss.

On 5-22-06, before me, Sasha Z. Paez, personally appeared James P. Coffin personally known to me (or proved to me on the basis of satisfactory evidence) to be the person(s) whose name(s) is/are subscribed to the within instrument, and acknowledged to me that he executed the same in his authorized capacity(ies), and that by his signature(s) on the instrument the person(s), or the entity upon behalf of which the person(s) acted, executed the instrument.

WITNESS my hand and official seal.

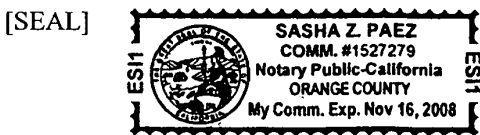

Sasha Z. Paez
Notary Signature

Application No.: 11/366,209
Filing Date: March 1, 2006

PATENT
Client Code: MLR.004A
Page 4

IN TESTIMONY WHEREOF, I hereunto set my hand and seal this 22 day of May, 2006

Yassir Abdul-Hafiz
Yassir Abdul-Hafiz

STATE OF Ca.
COUNTY OF Orange. } ss.

On 5-22-06, before me, Sasha Z. Paez, personally appeared Yassir Abdul-Hafiz personally known to me (or proved to me on the basis of satisfactory evidence) to be the person(s) whose name(s) is/are subscribed to the within instrument, and acknowledged to me that he executed the same in his authorized capacity(ies), and that by his signature(s) on the instrument the person(s), or the entity upon behalf of which the person(s) acted, executed the instrument.

WITNESS my hand and official seal.

[SEAL]



Notary Signature

Sasha Z. Paez

2602311
051506

UNITED STATES PATENT AND TRADEMARK OFFICE

UNITED STATES DEPARTMENT OF COMMERCE
 United States Patent and Trademark Office
 Address: COMMISSIONER FOR PATENTS
 P.O. Box 1450
 Alexandria, Virginia 22313-1450
 www.uspto.gov

APPLICATION NUMBER	FILING OR 371 (c) DATE	FIRST NAMED APPLICANT	ATTORNEY DOCKET NUMBER
11/366,209	03/01/2006	Ammar Al-Ali	MLR.004A

20995
 KNOBBE MARTENS OLSON & BEAR LLP
 2040 MAIN STREET
 FOURTEENTH FLOOR
 IRVINE, CA 92614

**CONFIRMATION NO. 2025
 FORMALITIES
 LETTER**

Date Mailed: 04/07/2006

NOTICE TO FILE MISSING PARTS OF NONPROVISIONAL APPLICATION

FILED UNDER 37 CFR 1.53(b)

Filing Date Granted

Items Required To Avoid Abandonment:

An application number and filing date have been accorded to this application. The item(s) indicated below, however, are missing. Applicant is given **TWO MONTHS** from the date of this Notice within which to file all required items and pay any fees required below to avoid abandonment. Extensions of time may be obtained by filing a petition accompanied by the extension fee under the provisions of 37 CFR 1.136(a).

- The statutory basic filing fee is missing.
Applicant must submit \$ 300 to complete the basic filing fee for a non-small entity. If appropriate, applicant may make a written assertion of entitlement to small entity status and pay the small entity filing fee (37 CFR 1.27).
- The oath or declaration is missing. *A properly signed oath or declaration in compliance with 37 CFR 1.63, identifying the application by the above Application Number and Filing Date, is required.*
Note: If a petition under 37 CFR 1.47 is being filed, an oath or declaration in compliance with 37 CFR 1.63 signed by all available joint inventors, or if no inventor is available by a party with sufficient proprietary interest, is required.

The applicant needs to satisfy supplemental fees problems indicated below.

The required item(s) identified below must be timely submitted to avoid abandonment:

- Additional claim fees of **\$200** as a non-small entity, including any required multiple dependent claim fee, are required. Applicant must submit the additional claim fees or cancel the additional claims for which fees are due.
- To avoid abandonment, a surcharge (for late submission of filing fee, search fee, examination fee or oath or declaration) as set forth in 37 CFR 1.16(f) of \$130 for a non-small entity, must be submitted with the missing items identified in this letter.

SUMMARY OF FEES DUE:

Total additional fee(s) required for this application is **\$1330** for a Large Entity

- **\$300** Statutory basic filing fee.
- **\$130** Surcharge.

- The application search fee has not been paid. Applicant must submit **\$500** to complete the search fee.
- The application examination fee has not been paid. Applicant must submit **\$200** to complete the examination fee for a large entity

- Total additional claim fee(s) for this application is **\$200**
 - **\$200** for 1 independent claims over 3.

Replies should be mailed to: Mail Stop Missing Parts
Commissioner for Patents
P.O. Box 1450
Alexandria VA 22313-1450

*A copy of this notice **MUST** be returned with the reply.*

Office of Initial Patent Examination (571) 272-4000, or 1-800-PTO-9199, or 1-800-972-6382
PART 3 - OFFICE COPY

030106

20427 U.S. PTO

UTILITY APPLICATION	Attorney Docket No.: MLR.004A
	First Named Inventor: Ammar Al-Ali
	Title: MULTIPLE WAVELENGTH SENSOR SUBSTRATE
	Express Mail Label No.: EV 718230785 US
Direct all correspondence to Customer No.: 20995	Date: March 1, 2006 Page 1

Commissioner for Patents
P.O. Box 1450
Alexandria, VA 22313-1450

112935 U.S. PTO
11/366209
030106

The following enclosures are transmitted herewith to be filed in the patent application of:

INVENTORS LIST:

1. Ammar Al-Ali
2. Mohamed Diab
3. Marcelo Lamego
4. James P. Coffin

DOMESTIC PRIORITY INFORMATION:

The present application claims priority benefit under 35 U.S.C. § 119(e) to U.S. Provisional Patent Application Serial No. 60/657,596, filed March 1, 2005, entitled "*Multiple Wavelength Sensor*," No. 60/657,281, filed March 1, 2005, entitled "*Physiological Parameter Confidence Measure*," No. 60/657,268, filed March 1, 2005, entitled "*Configurable Physiological Measurement System*," and No. 60/657,759, filed March 1, 2005, entitled "*Noninvasive Multi-Parameter Patient Monitor*." The present application incorporates the foregoing disclosures herein by reference.

UTILITY APPLICATION	Attorney Docket No.: MLR.004A
	First Named Inventor: Ammar Al-Ali Title: MULTIPLE WAVELENGTH SENSOR SUBSTRATE Express Mail Label No.: EV 718230785 US
Direct all correspondence to Customer No.: 20995	Date: March 1, 2006 Page 2

FILING FEES:

FEE CALCULATION				
FEE TYPE		FEE CODE	CALCULATION	TOTAL
Basic Utility	<i>1.16(a)(1)</i>	1011 (\$300)		\$300
Search Fee	<i>1.16(k)</i>	1111 (\$500)		\$500
Examination Fee	<i>1.16(o)</i>	1311 (\$200)		\$200
Excess Claims > 20	15 - 20 = 0	1202 (\$50)	0 x 50 =	\$0
Independent > 3	4 - 3 = 1	1201 (\$200)	1 x 200 =	\$200
Multiple Claim	<i>1.16(j)</i>	1203 (\$360)		\$0
Application Size Fee	84 - 100 = 0	1081 (\$250) [‡]	0 x 250 =	\$0
Recordation Fee	<i>1.21(h)</i>	8021 (\$40)	0 x 40 =	\$0
Non-English Spec.	<i>1.17(i)</i>	1053 (\$130)		\$0
			TOTAL FEE DUE	\$1,200

[‡]Each additional group of 0-50 pages requires this fee. For example, a 101 page application requires this fee once, a 157 page application requires two times this fee, and a 211 page application requires three times this fee.

ENCLOSED APPLICATION ELEMENTS:

1. Specification in 36 pages.
2. Drawings in 48 sheets.
3. Return prepaid postcard.

The total fees calculated above will be paid at a later date.

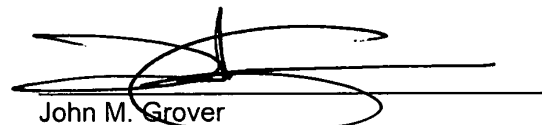
 John M. Grover
 Registration No. 42,610
 Attorney of Record
 Customer No. 20,995
 (949) 760-0404

2407634
022806

Knobbe Martens Olson & Bear LLP

Intellectual Property Law

2040 Main Street
Fourteenth Floor
Irvine, CA 92614
Tel 949-760-0404
Fax 949-760-9502
www.kmob.com

John M. Grover
jgrover@kmob.com

Commissioner for Patents
P.O. Box 1450
Alexandria, VA 22313-1450

CERTIFICATE OF MAILING BY "EXPRESS MAIL"

Attorney Docket No. : MLR.004A
Applicants : Ammar Al-Ali et al.
For : MULTIPLE WAVELENGTH SENSOR
SUBSTRATE
Attorney : John M. Grover
"Express Mail"
Mailing Label No. : EV 718230785 US
Date of Deposit : March 1, 2006

I hereby certify that the accompanying

Transmittal Letter; Specification in 36 pages; 48 sheets of Drawings;
Return Prepaid Postcard

are being deposited with the United States Postal Service "Express Mail Post Office to Addressee" service under 37 CFR 1.10 on the date indicated above and are addressed to the Commissioner for Patents, P.O. Box 1450, Alexandria, VA 22313-1450.

John Grover

2407636
022806

San Diego
619-235-8550

San Francisco
415-954-4114

Los Angeles
310-551-3450

Riverside
951-781-9231

San Luis Obispo
805-547-5580

MULTIPLE WAVELENGTH SENSOR SUBSTRATEPRIORITY CLAIM TO RELATED PROVISIONAL APPLICATIONS

[0001] The present application claims priority benefit under 35 U.S.C. § 119(e) to U.S. Provisional Patent Application Serial No. 60/657,596, filed March 1, 2005, entitled "*Multiple Wavelength Sensor*," No. 60/657,281, filed March 1, 2005, entitled "*Physiological Parameter Confidence Measure*," No. 60/657,268, filed March 1, 2005, entitled "*Configurable Physiological Measurement System*," and No. 60/657,759, filed March 1, 2005, entitled "*Noninvasive Multi-Parameter Patient Monitor*." The present application incorporates the foregoing disclosures herein by reference.

INCORPORATION BY REFERENCE OF COPENDING RELATED APPLICATIONS

[0002] The present application is related to the following copending U.S. utility applications:

	App. Sr. No.	Filing Date	Title	Atty Dock.
1	11/####,###	March 1, 2006	Multiple Wavelength Sensor Emitters	MLR.002A
2	11/####,###	March 1, 2006	Multiple Wavelength Sensor Equalization	MLR.003A
3	11/####,###	March 1, 2006	Multiple Wavelength Sensor Substrate	MLR.004A
4	11/####,###	March 1, 2006	Multiple Wavelength Sensor Interconnect	MLR.005A
5	11/####,###	March 1, 2006	Multiple Wavelength Sensor Attachment	MLR.006A
6	11/####,###	March 1, 2006	Multiple Wavelength Sensor Drivers	MLR.009A
7	11/####,###	March 1, 2006	Physiological Parameter Confidence Measure	MLR.010A
8	11/####,###	March 1, 2006	Configurable Physiological Measurement System	MLR.011A
9	11/####,###	March 1, 2006	Noninvasive Multi-Parameter Patient Monitor	MLR.012A
10	11/####,###	March 1, 2006	Noninvasive Multi-Parameter Patient Monitor	MLR.013A
11	11/####,###	March 1, 2006	Noninvasive Multi-Parameter Patient Monitor	MLR.014A

The present application incorporates the foregoing disclosures herein by reference.

BACKGROUND OF THE INVENTION

[0003] Spectroscopy is a common technique for measuring the concentration of organic and some inorganic constituents of a solution. The theoretical basis of this technique is the Beer-Lambert law, which states that the concentration c_i of an absorbent in solution can be determined by the intensity of light transmitted through the solution, knowing the pathlength d_λ , the intensity of the incident light $I_{0,\lambda}$, and the extinction coefficient $\epsilon_{i,\lambda}$ at a particular wavelength λ . In generalized form, the Beer-Lambert law is expressed as:

$$I_\lambda = I_{0,\lambda} e^{-d_\lambda \cdot \mu_{a,\lambda}} \quad (1)$$

$$\mu_{a,\lambda} = \sum_{i=1}^n \epsilon_{i,\lambda} \cdot c_i \quad (2)$$

where $\mu_{a,\lambda}$ is the bulk absorption coefficient and represents the probability of absorption per unit length. The minimum number of discrete wavelengths that are required to solve EQS. 1-2 are the number of significant absorbers that are present in the solution.

[0004] A practical application of this technique is pulse oximetry, which utilizes a noninvasive sensor to measure oxygen saturation (SpO_2) and pulse rate. In general, the sensor has light emitting diodes (LEDs) that transmit optical radiation of red and infrared wavelengths into a tissue site and a detector that responds to the intensity of the optical radiation after absorption (e.g., by transmission or transreflectance) by pulsatile arterial blood flowing within the tissue site. Based on this response, a processor determines measurements for SpO_2 , pulse rate, and can output representative plethysmographic waveforms. Thus, "pulse oximetry" as used herein encompasses its broad ordinary meaning known to one of skill in the art, which includes at least those noninvasive procedures for measuring parameters of circulating blood through spectroscopy. Moreover, "plethysmograph" as used herein (commonly referred to as "photoplethysmograph"), encompasses its broad ordinary meaning known to one of skill in the art, which includes at least data representative of a change in the absorption of particular wavelengths of light as a function of the changes in body tissue resulting from pulsing blood. Pulse oximeters capable of

reading through motion induced noise are available from Masimo Corporation ("Masimo") of Irvine, California. Moreover, portable and other oximeters capable of reading through motion induced noise are disclosed in at least U.S. Pat. Nos. 6,770,028, 6,658,276, 6,157,850, 6,002,952 5,769,785, and 5,758,644, which are owned by Masimo and are incorporated by reference herein. Such reading through motion oximeters have gained rapid acceptance in a wide variety of medical applications, including surgical wards, intensive care and neonatal units, general wards, home care, physical training, and virtually all types of monitoring scenarios.

SUMMARY OF THE INVENTION

[0005] There is a need to noninvasively measure multiple physiological parameters, other than, or in addition to, oxygen saturation and pulse rate. For example, hemoglobin species that are also significant under certain circumstances are carboxyhemoglobin and methemoglobin. Other blood parameters that may be measured to provide important clinical information are fractional oxygen saturation, total hemaglobin (Hbt), bilirubin and blood glucose, to name a few.

[0006] One aspect of a physiological sensor is emitters configured to transmit optical radiation having multiple wavelengths in response to corresponding drive currents. A thermal mass is disposed proximate the emitters so as to stabilize a bulk temperature for the emitters. A temperature sensor is thermally coupled to the thermal mass. The temperature sensor provides a temperature sensor output responsive to the bulk temperature so that the wavelengths are determinable as a function of the drive currents and the bulk temperature.

[0007] Another aspect of a physiological sensor capable of emitting light into tissue and producing an output signal usable to determine one or more physiological parameters of a patient is a thermal mass. Light emitting sources are thermally coupled to the thermal mass. The sources have corresponding multiple operating wavelengths. A temperature sensor is thermally coupled to the thermal mass and is capable of determining a bulk temperature for the thermal mass, where the operating wavelengths are dependent on the bulk temperature. A detector is capable of detecting light emitted by the light emitting sources after tissue

attenuation and is capable of outputting a signal usable to determine one or more physiological parameters of a patient based upon the operating wavelengths.

[0008] A further aspect of a physiological sensor adapted to determine a physiological parameter using light emitting sources with emission wavelengths affected by one or more dynamic operating parameters is to transmit optical radiation from the light emitting sources into body tissue. The optical radiation is detected after tissue attenuation. Multiple operating wavelengths of the light emitting sources are determined dependent on a bulk temperature of the light emitting sources. One or more physiological parameters of a patient are determined based upon the operating wavelengths.

[0009] An additional aspect of a physiological sensor is a sensor adapted to determine a physiological parameter using light emitting sources with emission wavelengths affected by one or more dynamic operating parameters. Optical radiation is transmitted from the light emitting sources into body tissue. The optical radiation is detected after tissue attenuation. An operating wavelength for each of the light emitting sources is indicated.

BRIEF DESCRIPTION OF THE DRAWINGS

- [0010] FIG. 1 is a perspective view of a physiological measurement system utilizing a multiple wavelength sensor;
- [0011] FIGS. 2A-C are perspective views of multiple wavelength sensor embodiments;
- [0012] FIG. 3 is a general block diagram of a multiple wavelength sensor and sensor controller;
- [0013] FIG. 4 is an exploded perspective view of a multiple wavelength sensor embodiment;
- [0014] FIG. 5 is a general block diagram of an emitter assembly;
- [0015] FIG. 6 is a perspective view of an emitter assembly embodiment;
- [0016] FIG. 7 is a general block diagram of an emitter array;
- [0017] FIG. 8 is a schematic diagram of an emitter array embodiment;
- [0018] FIG. 9 is a general block diagram of equalization;
- [0019] FIGS. 10A-D are block diagrams of various equalization embodiments;
- [0020] FIGS. 11A-C are perspective views of an emitter assembly incorporating various equalization embodiments;
- [0021] FIG. 12 is a general block diagram of an emitter substrate;
- [0022] FIGS. 13-14 are top and detailed side views of an emitter substrate embodiment;
- [0023] FIG. 15-16 are top and bottom component layout views of an emitter substrate embodiment;
- [0024] FIG. 17 is a schematic diagram of an emitter substrate embodiment;
- [0025] FIG. 18 is a plan view of an inner layer of an emitter substrate embodiment;
- [0026] FIG. 19 is a general block diagram of an interconnect assembly in relationship to other sensor assemblies;
- [0027] FIG. 20 is a block diagram of an interconnect assembly embodiment;
- [0028] FIG. 21 is a partially-exploded perspective view of a flex circuit assembly embodiment of an interconnect assembly;
- [0029] FIG. 22 is a top plan view of a flex circuit;

[0030] FIG. 23 is an exploded perspective view of an emitter portion of a flex circuit assembly;

[0031] FIG. 24 is an exploded perspective view of a detector assembly embodiment;

[0032] FIGS. 25-26 are block diagrams of adjacent detector and stacked detector embodiments;

[0033] FIG. 27 is a block diagram of a finger clip embodiment of an attachment assembly;

[0034] FIG. 28 is a general block diagram of a detector pad;

[0035] FIGS. 29A-B are perspective views of detector pad embodiments;

[0036] FIGS. 30A-H are perspective bottom, perspective top, bottom, back, top, side cross sectional, side, and front cross sectional views of an emitter pad embodiment;

[0037] FIGS. 31A-H are perspective bottom, perspective top, top, back, bottom, side cross sectional, side, and front cross sectional views of a detector pad embodiment;

[0038] FIGS. 32A-H are perspective bottom, perspective top, top, back, bottom, side cross sectional, side, and front cross sectional views of a shoe box;

[0039] FIGS. 33A-H are perspective bottom, perspective top, top, back, bottom, side cross sectional, side, and front cross sectional views of a slim-finger emitter pad embodiment;

[0040] FIGS. 34A-H are perspective bottom, perspective top, top, back, bottom, side cross sectional, side, and front cross sectional views of a slim-finger detector pad embodiment;

[0041] FIGS. 35A-B are plan and cross sectional views, respectively, of a spring assembly embodiment;

[0042] FIGS. 36A-C are top, perspective and side views of a finger clip spring;

[0043] FIGS. 37A-D are top, back, bottom, and side views of a spring plate;

[0044] FIGS. 38A-D are front cross sectional, bottom, front and side cross sectional views of an emitter-pad shell;

- [0045] FIGS. **39A-D** are back, top, front and side cross sectional views of a detector-pad shell;
- [0046] FIG. **40** is a general block diagram of a monitor and a sensor;
- [0047] FIGS. **41A-C** are schematic diagrams of grid drive embodiments for a sensor having back-to-back diodes and an information element;
- [0048] FIGS. **42** is a schematic diagrams of a grid drive embodiment for an information element;
- [0049] FIGS. **43A-C** are schematic diagrams for grid drive readable information elements;
- [0050] FIGS. **44A-B** are cross sectional and side cut away views of a sensor cable;
- [0051] FIG. **45** is a block diagram of a sensor controller embodiment; and
- [0052] FIG. **46** is a detailed exploded perspective view of a multiple wavelength sensor embodiment.

DETAILED DESCRIPTION OF THE PREFERRED EMBODIMENTS

Overview

[0053] In this application, reference is made to many blood parameters. Some references that have common shorthand designations are referenced through such shorthand designations. For example, as used herein, HbCO designates carboxyhemoglobin, HbMet designates methemoglobin, and Hbt designates total hemoglobin. Other shorthand designations such as COHb, MetHb, and tHb are also common in the art for these same constituents. These constituents are generally reported in terms of a percentage, often referred to as saturation, relative concentration or fractional saturation. Total hemoglobin is generally reported as a concentration in g/dL. The use of the particular shorthand designators presented in this application does not restrict the term to any particular manner in which the designated constituent is reported.

[0054] FIG. 1 illustrates a physiological measurement system **10** having a monitor **100** and a multiple wavelength sensor assembly **200** with enhanced measurement capabilities as compared with conventional pulse oximetry. The physiological measurement system **10** allows the monitoring of a person, including a patient. In particular, the multiple wavelength sensor assembly **200** allows the measurement of blood constituent and related parameters in addition to oxygen saturation and pulse rate. Alternatively, the multiple wavelength sensor assembly **200** allows the measurement of oxygen saturation and pulse rate with increased accuracy or robustness as compared with conventional pulse oximetry.

[0055] In one embodiment, the sensor assembly **200** is configured to plug into a monitor sensor port **110**. Monitor keys **160** provide control over operating modes and alarms, to name a few. A display **170** provides readouts of measured parameters, such as oxygen saturation, pulse rate, HbCO and HbMet to name a few.

[0056] FIGS. 2A illustrates a multiple wavelength sensor assembly **200** having a sensor **400** adapted to attach to a tissue site, a sensor cable **4400** and a monitor connector **210**. In one embodiment, the sensor **400** is incorporated into a reusable finger clip adapted to removably attach to, and transmit light through, a fingertip. The sensor cable **4400** and monitor connector **210** are integral to the sensor **400**, as

shown. In alternative embodiments, the sensor **400** may be configured separately from the cable **4400** and connector **210**.

[0057] FIGS. **2B-C** illustrate alternative sensor embodiments, including a sensor **401** (FIG. **2B**) partially disposable and partially reusable (resposable) and utilizing an adhesive attachment mechanism. Also shown is a sensor **402** (FIG. **2C**) being disposable and utilizing an adhesive attachment mechanism. In other embodiments, a sensor may be configured to attach to various tissue sites other than a finger, such as a foot or an ear. Also a sensor may be configured as a reflectance or transreflectance device that attaches to a forehead or other tissue surface.

[0058] FIG. **3** illustrates a sensor assembly **400** having an emitter assembly **500**, a detector assembly **2400**, an interconnect assembly **1900** and an attachment assembly **2700**. The emitter assembly **500** responds to drive signals received from a sensor controller **4500** in the monitor **100** via the cable **4400** so as to transmit optical radiation having a plurality of wavelengths into a tissue site. The detector assembly **2400** provides a sensor signal to the monitor **100** via the cable **4400** in response to optical radiation received after attenuation by the tissue site. The interconnect assembly **1900** provides electrical communication between the cable **4400** and both the emitter assembly **500** and the detector assembly **2400**. The attachment assembly **2700** attaches the emitter assembly **500** and detector assembly **2400** to a tissue site, as described above. The emitter assembly **500** is described in further detail with respect to FIG. **5**, below. The interconnect assembly **1900** is described in further detail with respect to FIG. **19**, below. The detector assembly **2400** is described in further detail with respect to FIG. **24**, below. The attachment assembly **2700** is described in further detail with respect to FIG. **27**, below.

[0059] FIG. **4** illustrates a sensor **400** embodiment that removably attaches to a fingertip. The sensor **400** houses a multiple wavelength emitter assembly **500** and corresponding detector assembly **2400**. A flex circuit assembly **1900** mounts the emitter and detector assemblies **500**, **2400** and interconnects them to a multi-wire sensor cable **4400**. Advantageously, the sensor **400** is configured in several

respects for both wearer comfort and parameter measurement performance. The flex circuit assembly **1900** is configured to mechanically decouple the cable **4400** wires from the emitter and detector assemblies **500**, **2400** to reduce pad stiffness and wearer discomfort. The pads **3000**, **3100** are mechanically decoupled from shells **3800**, **3900** to increase flexibility and wearer comfort. A spring **3600** is configured in hinged shells **3800**, **3900** so that the pivot point of the finger clip is well behind the fingertip, improving finger attachment and more evenly distributing the clip pressure along the finger.

[0060] As shown in FIG. 4, the detector pad **3100** is structured to properly position a fingertip in relationship to the detector assembly **2400**. The pads have flaps that block ambient light. The detector assembly **2400** is housed in an enclosure so as to reduce light piping from the emitter assembly to the detector assembly without passing through fingertip tissue. These and other features are described in detail below. Specifically, emitter assembly embodiments are described with respect to FIGS. 5-18. Interconnect assembly embodiments, including the flexible circuit assembly **1900**, are described with respect to FIGS. 19-23. Detector assembly embodiments are described with respect to FIGS. 24-26. Attachment assembly embodiments are described with respect to FIGS. 27-39.

Emitter Assembly

[0061] FIG. 5 illustrates an emitter assembly **500** having an emitter array **700**, a substrate **1200** and equalization **900**. The emitter array **700** has multiple light emitting sources, each activated by addressing at least one row and at least one column of an electrical grid. The light emitting sources are capable of transmitting optical radiation having multiple wavelengths. The equalization **900** accounts for differences in tissue attenuation of the optical radiation across the multiple wavelengths so as to at least reduce wavelength-dependent variations in detected intensity. The substrate **1200** provides a physical mount for the emitter array and emitter-related equalization and a connection between the emitter array and the interconnection assembly. Advantageously, the substrate **1200** also provides a bulk temperature measurement so as to calculate the operating wavelengths for the light

emitting sources. The emitter array **700** is described in further detail with respect to FIG. **7**, below. Equalization is described in further detail with respect to FIG. **9**, below. The substrate **1200** is described in further detail with respect to FIG. **12**, below.

[0062] FIG. **6** illustrates an emitter assembly **500** embodiment having an emitter array **700**, an encapsulant **600**, an optical filter **1100** and a substrate **1200**. Various aspects of the emitter assembly **500** are described with respect to FIGS. **7-18**, below. The emitter array **700** emits optical radiation having multiple wavelengths of predetermined nominal values, advantageously allowing multiple parameter measurements. In particular, the emitter array **700** has multiple light emitting diodes (LEDs) **710** that are physically arranged and electrically connected in an electrical grid to facilitate drive control, equalization, and minimization of optical pathlength differences at particular wavelengths. The optical filter **1100** is advantageously configured to provide intensity equalization across a specific LED subset. The substrate **1200** is configured to provide a bulk temperature of the emitter array **700** so as to better determine LED operating wavelengths.

Emitter Array

[0063] FIG. **7** illustrates an emitter array **700** having multiple light emitters (LE) **710** capable of emitting light **702** having multiple wavelengths into a tissue site **1**. Row drivers **4530** and column drivers **4560** are electrically connected to the light emitters **710** and activate one or more light emitters **710** by addressing at least one row **720** and at least one column **740** of an electrical grid. In one embodiment, the light emitters **710** each include a first contact **712** and a second contact **714**. The first contact **712** of a first subset **730** of light emitters is in communication with a first conductor **720** of the electrical grid. The second contact **714** of a second subset **750** of light emitters is in communication with a second conductor **740**. Each subset comprises at least two light emitters, and at least one of the light emitters of the first and second subsets **730**, **750** are not in common. A detector **2400** is capable of detecting the emitted light **702** and outputting a sensor signal **2500** responsive to the emitted light **702** after attenuation by the tissue site **1**. As such, the sensor

signal **2500** is indicative of at least one physiological parameter corresponding to the tissue site **1**, as described above.

[0064] FIG. **8** illustrates an emitter array **700** having LEDs **801** connected within an electrical grid of n rows and m columns totaling $n + m$ drive lines **4501**, **4502**, where n and m integers greater than one. The electrical grid advantageously minimizes the number of drive lines required to activate the LEDs **801** while preserving flexibility to selectively activate individual LEDs **801** in any sequence and multiple LEDs **801** simultaneously. The electrical grid also facilitates setting LED currents so as to control intensity at each wavelength, determining operating wavelengths and monitoring total grid current so as to limit power dissipation. The emitter array **700** is also physically configured in rows **810**. This physical organization facilitates clustering LEDs **801** according to wavelength so as to minimize pathlength variations and facilitates equalization of LED intensities.

[0065] As shown in FIG. **8**, one embodiment of an emitter array **700** comprises up to sixteen LEDs **801** configured in an electrical grid of four rows **810** and four columns **820**. Each of the four row drive lines **4501** provide a common anode connection to four LEDs **801**, and each of the four column drive lines **4502** provide a common cathode connection to four LEDs **801**. Thus, the sixteen LEDs **801** are advantageously driven with only eight wires, including four anode drive lines **812** and four cathode drive lines **822**. This compares favorably to conventional common anode or cathode LED configurations, which require more drive lines. In a particular embodiment, the emitter array **700** is partially populated with eight LEDs having nominal wavelengths as shown in TABLE **1**. Further, LEDs having wavelengths in the range of 610-630 nm are grouped together in the same row. The emitter array **700** is adapted to a physiological measurement system **10** (FIG. **1**) for measuring H_bCO and/or METHb in addition to S_pO_2 and pulse rate.

LED	λ	Row	Col
D1	630	1	1
D2	620	1	2
D3	610	1	3
D4		1	4
D5	700	2	1
D6	730	2	2
D7	660	2	3
D8	805	2	4
D9		3	1
D10		3	2
D11		3	3
D12	905	3	4
D13		4	1
D14		4	2
D15		4	3
D16		4	4

TABLE 1: Nominal LED Wavelengths

[0066] Also shown in FIG. 8, row drivers **4530** and column drivers **4560** located in the monitor **100** selectively activate the LEDs **801**. In particular, row and column drivers **4530**, **4560** function together as switches to Vcc and current sinks, respectively, to activate LEDs and as switches to ground and Vcc, respectively, to deactivate LEDs. This push-pull drive configuration advantageously prevents parasitic current flow in deactivated LEDs. In a particular embodiment, only one row drive line **4501** is switched to Vcc at a time. One to four column drive lines **4502**, however, can be simultaneously switched to a current sink so as to simultaneously activate multiple LEDs within a particular row. Activation of two or more LEDs of the same wavelength facilitates intensity equalization, as described with respect to FIGS. 9-11, below. LED drivers are described in further detail with respect to FIG. 45, below.

[0067] Although an emitter assembly is described above with respect to an array of light emitters each configured to transmit optical radiation centered around a nominal wavelength, in another embodiment, an emitter assembly advantageously utilizes one or more tunable broadband light sources, including the use of filters to

select the wavelength, so as to minimize wavelength-dependent pathlength differences from emitter to detector. In yet another emitter assembly embodiment, optical radiation from multiple emitters each configured to transmit optical radiation centered around a nominal wavelength is funneled to a tissue site point so as to minimize wavelength-dependent pathlength differences. This funneling may be accomplished with fiberoptics or mirrors, for example. In further embodiments, the LEDs **801** can be configured with alternative orientations with correspondingly different drivers among various other configurations of LEDs, drivers and interconnecting conductors.

Equalization

[0068] FIG. **9** illustrate a physiological parameter measurement system **10** having a controller **4500**, an emitter assembly **500**, a detector assembly **2400** and a front-end **4030**. The emitter assembly **500** is configured to transmit optical radiation having multiple wavelengths into the tissue site **1**. The detector assembly **2400** is configured to generate a sensor signal **2500** responsive to the optical radiation after tissue attenuation. The front-end **4030** conditions the sensor signal **2500** prior to analog-to-digital conversion (ADC).

[0069] FIG. **9** also generally illustrates equalization **900** in a physiological measurement system **10** operating on a tissue site **1**. Equalization encompasses features incorporated into the system **10** in order to provide a sensor signal **2500** that falls well within the dynamic range of the ADC across the entire spectrum of emitter wavelengths. In particular, equalization compensates for the imbalance in tissue light absorption due to Hb and HbO₂ **910**. Specifically, these blood constituents attenuate red wavelengths greater than IR wavelengths. Ideally, equalization **900** balances this unequal attenuation. Equalization **900** can be introduced anywhere in the system **10** from the controller **4500** to front-end **4000** and can include compensatory attenuation versus wavelength, as shown, or compensatory amplification versus or both.

[0070] Equalization can be achieved to a limited extent by adjusting drive currents from the controller **4500** and front-end **4030** amplification accordingly to

wavelength so as to compensate for tissue absorption characteristics. Signal demodulation constraints, however, limit the magnitude of these adjustments. Advantageously, equalization **900** is also provided along the optical path from emitters **500** to detector **2400**. Equalization embodiments are described in further detail with respect to FIGS. **10-11**, below.

[0071] FIGS. **10A-D** illustrate various equalization embodiments having an emitter array **700** adapted to transmit optical radiation into a tissue site **1** and a detector assembly **2400** adapted to generate a sensor signal **2500** responsive to the optical radiation after tissue attenuation. FIG. **10A** illustrates an optical filter **1100** that attenuates at least a portion of the optical radiation before it is transmitted into a tissue site **1**. In particular, the optical filter **1100** attenuates at least a portion of the IR wavelength spectrum of the optical radiation so as to approximate an equalization curve **900** (FIG. **9**). FIG. **10B** illustrates an optical filter **1100** that attenuates at least a portion of the optical radiation after it is attenuated by a tissue site **1**, where the optical filter **1100** approximates an equalization curve **900** (FIG. **9**).

[0072] FIG. **10C** illustrates an emitter array **700** where at least a portion of the emitter array generates one or more wavelengths from multiple light emitters **710** of the same wavelength. In particular, the same-wavelength light emitters **710** boost at least a portion of the red wavelength spectrum so as to approximately equalize the attenuation curves **910** (FIG. **9**). FIG. **10D** illustrates a detector assembly **2400** having multiple detectors **2610**, **2620** selected so as to equalize the attenuation curves **910** (FIG. **9**). To a limited extent, optical equalization can also be achieved by selection of particular emitter array **700** and detector **2400** components, e.g. LEDs having higher output intensities or detectors having higher sensitivities at red wavelengths. Although equalization embodiments are described above with respect to red and IR wavelengths, these equalization embodiments can be applied to equalize tissue characteristics across any portion of the optical spectrum.

[0073] FIGS. **11A-C** illustrates an optical filter **1100** for an emitter assembly **500** that advantageously provides optical equalization, as described above. LEDs within the emitter array **700** may be grouped according to output intensity or wavelength or both. Such a grouping facilitates equalization of LED intensity across the array. In

particular, relatively low tissue absorption and/or relatively high output intensity LEDs can be grouped together under a relatively high attenuation optical filter. Likewise, relatively low tissue absorption and/or relatively low output intensity LEDs can be grouped together without an optical filter or under a relatively low or negligible attenuation optical filter. Further, high tissue absorption and/or low intensity LEDs can be grouped within the same row with one or more LEDs of the same wavelength being simultaneously activated, as described with respect to FIG. **10C**, above. In general, there can be any number of LED groups and any number of LEDs within a group. There can also be any number of optical filters corresponding to the groups having a range of attenuation, including no optical filter and/or a "clear" filter having negligible attenuation.

[0074] As shown in FIGS. **11A-C**, a filtering media may be advantageously added to an encapsulant that functions both as a cover to protect LEDs and bonding wires and as an optical filter **1100**. In one embodiment, a filtering media **1100** encapsulates a select group of LEDs and a clear media **600** (FIG. **6**) encapsulates the entire array **700** and the filtering media **1000** (FIG. **6**). In a particular embodiment, corresponding to TABLE 1, above, five LEDs nominally emitting at 660-905 nm are encapsulated with both a filtering media **1100** and an overlying clear media **600** (FIG. **6**), i.e. attenuated. In a particular embodiment, the filtering media **1100** is a 40:1 mixture of a clear encapsulant (EPO-TEK OG147-7) and an opaque encapsulate (EPO-TEK OG147) both available from Epoxy Technology, Inc., Billerica, MA. Three LEDs nominally emitting at 610-630 nm are only encapsulated with the clear media **600** (FIG. **6**), i.e. unattenuated. In alternative embodiments, individual LEDs may be singly or multiply encapsulated according to tissue absorption and/or output intensity. In other alternative embodiments, filtering media may be separately attachable optical filters or a combination of encapsulants and separately attachable optical filters. In a particular embodiment, the emitter assembly **500** has one or more notches along each side proximate the component end **1305** (FIG. **13**) for retaining one or more clip-on optical filters.

Substrate

[0075] FIG. 12 illustrates light emitters 710 configured to transmit optical radiation 1201 having multiple wavelengths in response to corresponding drive currents 1210. A thermal mass 1220 is disposed proximate the emitters 710 so as to stabilize a bulk temperature 1202 for the emitters. A temperature sensor 1230 is thermally coupled to the thermal mass 1220, wherein the temperature sensor 1230 provides a temperature sensor output 1232 responsive to the bulk temperature 1202 so that the wavelengths are determinable as a function of the drive currents 1210 and the bulk temperature 1202.

[0076] In one embodiment, an operating wavelength λ_a of each light emitter 710 is determined according to EQ. 3

$$\lambda_a = f(T_b, I_{drive}, \sum I_{drive}) \quad (3)$$

where T_b is the bulk temperature, I_{drive} is the drive current for a particular light emitter, as determined by the sensor controller 4500 (FIG. 45), described below, and $\sum I_{drive}$ is the total drive current for all light emitters. In another embodiment, temperature sensors are configured to measure the temperature of each light emitter 710 and an operating wavelength λ_a of each light emitter 710 is determined according to EQ. 4

$$\lambda_a = f(T_a, I_{drive}, \sum I_{drive}) \quad (4)$$

where T_a is the temperature of a particular light emitter, I_{drive} is the drive current for that light emitter and $\sum I_{drive}$ is the total drive current for all light emitters.

[0077] In yet another embodiment, an operating wavelength for each light emitter is determined by measuring the junction voltage for each light emitter 710. In a further embodiment, the temperature of each light emitter 710 is controlled, such as by one or more Peltier cells coupled to each light emitter 710, and an operating wavelength for each light emitter 710 is determined as a function of the resulting controlled temperature or temperatures. In other embodiments, the operating wavelength for each light emitter 710 is determined directly, for example by attaching a charge coupled device (CCD) to each light emitter or by attaching a

fiberoptic to each light emitter and coupling the fiberoptics to a wavelength measuring device, to name a few.

[0078] FIGS. 13-18 illustrate one embodiment of a substrate 1200 configured to provide thermal conductivity between an emitter array 700 (FIG. 8) and a thermistor 1540 (FIG. 16). In this manner, the resistance of the thermistor 1540 (FIG. 16) can be measured in order to determine the bulk temperature of LEDs 801 (FIG. 8) mounted on the substrate 1200. The substrate 1200 is also configured with a relatively significant thermal mass, which stabilizes and normalizes the bulk temperature so that the thermistor measurement of bulk temperature is meaningful.

[0079] FIGS. 13-14 illustrate a substrate 1200 having a component side 1301, a solder side 1302, a component end 1305 and a connector end 1306. Alignment notches 1310 are disposed between the ends 1305, 1306. The substrate 1200 further has a component layer 1401, inner layers 1402-1405 and a solder layer 1406. The inner layers 1402-1405, e.g. inner layer 1402 (FIG. 18), have substantial metallized areas 1411 that provide a thermal mass 1220 (FIG. 12) to stabilize a bulk temperature for the emitter array 700 (FIG. 12). The metallized areas 1411 also function to interconnect component pads 1510 and wire bond pads 1520 (FIG. 15) to the connector 1530.

[0080] FIGS. 15-16 illustrate a substrate 1200 having component pads 1510 and wire bond pads 1520 at a component end 1305. The component pads 1510 mount and electrically connect a first side (anode or cathode) of the LEDs 801 (FIG. 8) to the substrate 1200. Wire bond pads 1520 electrically connect a second side (cathode or anode) of the LEDs 801 (FIG. 8) to the substrate 1200. The connector end 1306 has a connector 1530 with connector pads 1532, 1534 that mount and electrically connect the emitter assembly 500 (FIG. 23), including the substrate 1200, to the flex circuit 2200 (FIG. 22). Substrate layers 1401-1406 (FIG. 14) have traces that electrically connect the component pads 1510 and wire bond pads 1520 to the connector 1532-1534. A thermistor 1540 is mounted to thermistor pads 1550 at the component end 1305, which are also electrically connected with traces to the

connector **1530**. Plated thru holes electrically connect the connector pads **1532**, **1534** on the component and solder sides **1301**, **1302**, respectively.

[0081] FIG. 17 illustrates the electrical layout of a substrate **1200**. A portion of the LEDs **801**, including D1-D4 and D13-D16 have cathodes physically and electrically connected to component pads **1510** (FIG. 15) and corresponding anodes wire bonded to wire bond pads **1520**. Another portion of the LEDs **801**, including D5-D8 and D9-D12, have anodes physically and electrically connected to component pads **1510** (FIG. 15) and corresponding cathodes wire bonded to wire bond pads **1520**. The connector **1530** has row pinouts J21-J24, column pinouts J31-J34 and thermistor pinouts J40-J41 for the LEDs **801** and thermistor **1540**.

Interconnect Assembly

[0082] FIG. 19 illustrates an interconnect assembly **1900** that mounts the emitter assembly **500** and detector assembly **2400**, connects to the sensor cable **4400** and provides electrical communications between the cable and each of the emitter assembly **500** and detector assembly **2400**. In one embodiment, the interconnect assembly **1900** is incorporated with the attachment assembly **2700**, which holds the emitter and detector assemblies to a tissue site. An interconnect assembly embodiment utilizing a flexible (flex) circuit is described with respect to FIGS. 20-24, below.

[0083] FIG. 20 illustrates an interconnect assembly **1900** embodiment having a circuit substrate **2200**, an emitter mount **2210**, a detector mount **2220** and a cable connector **2230**. The emitter mount **2210**, detector mount **2220** and cable connector **2230** are disposed on the circuit substrate **2200**. The emitter mount **2210** is adapted to mount an emitter assembly **500** having multiple emitters. The detector mount **2220** is adapted to mount a detector assembly **2400** having a detector. The cable connector **2230** is adapted to attach a sensor cable **4400**. A first plurality of conductors **2040** disposed on the circuit substrate **2200** electrically interconnects the emitter mount **2210** and the cable connector **2230**. A second plurality of conductors **2050** disposed on the circuit substrate **2200** electrically interconnects the detector mount **2220** and the cable connector **2230**. A decoupling **2060** disposed proximate

the cable connector **2230** substantially mechanically isolates the cable connector **2230** from both the emitter mount **2210** and the detector mount **2220** so that sensor cable stiffness is not translated to the emitter assembly **500** or the detector assembly **2400**. A shield **2070** is adapted to fold over and shield one or more wires or pairs of wires of the sensor cable **4400**.

[0084] FIG. **21** illustrates a flex circuit assembly **1900** having a flex circuit **2200**, an emitter assembly **500** and a detector assembly **2400**, which is configured to terminate the sensor end of a sensor cable **4400**. The flex circuit assembly **1900** advantageously provides a structure that electrically connects yet mechanically isolates the sensor cable **4400**, the emitter assembly **500** and the detector assembly **2400**. As a result, the mechanical stiffness of the sensor cable **4400** is not translated to the sensor pads **3000**, **3100** (FIGS. **30-31**), allowing a comfortable finger attachment for the sensor **200** (FIG. **1**). In particular, the emitter assembly **500** and detector assembly **2400** are mounted to opposite ends **2201**, **2202** (FIG. **22**) of an elongated flex circuit **2200**. The sensor cable **4400** is mounted to a cable connector **2230** extending from a middle portion of the flex circuit **2200**. Detector wires **4470** are shielded at the flex circuit junction by a fold-over conductive ink flap **2240**, which is connected to a cable inner shield **4450**. The flex circuit **2200** is described in further detail with respect to FIG. **22**. The emitter portion of the flex circuit assembly **1900** is described in further detail with respect to FIG. **23**. The detector assembly **2400** is described with respect to FIG. **24**. The sensor cable **4400** is described with respect to FIGS. **44A-B**, below.

[0085] FIG. **22** illustrates a sensor flex circuit **2200** having an emitter end **2201**, a detector end **2202**, an elongated interconnect **2204**, **2206** between the ends **2201**, **2202** and a cable connector **2230** extending from the interconnect **2204**, **2206**. The emitter end **2201** forms a "head" having emitter solder pads **2210** for attaching the emitter assembly **500** (FIG. **6**) and mounting ears **2214** for attaching to the emitter pad **3000** (FIG. **30B**), as described below. The detector end **2202** has detector solder pads for attaching the detector **2410** (FIG. **24**). The interconnect **2204** between the emitter end **2201** and the cable connector **2230** forms a "neck," and

the interconnect **2206** between the detector end **2202** and the cable connector **2230** forms a "tail." The cable connector **2230** forms "wings" that extend from the interconnect **2204**, **2206** between the neck **2204** and tail **2206**. A conductive ink flap **2240** connects to the cable inner shield **4450** (FIGS. **44A-B**) and folds over to shield the detector wires **4470** (FIGS. **44A-B**) soldered to the detector wire pads **2236**. The outer wire pads **2238** connect to the remaining cable wires **4430** (FIGS. **44A-B**). The flex circuit **2200** has top coverlay, top ink, inner coverlay, trace, trace base, bottom ink and bottom coverlay layers.

[0086] The flex circuit **2200** advantageously provides a connection between a multiple wire sensor cable **4400** (FIGS. **44A-B**), a multiple wavelength emitter assembly **500** (FIG. **6**) and a detector assembly **2400** (FIG. **24**) without rendering the emitter and detector assemblies unwieldy and stiff. In particular, the wings **2230** provide a relatively large solder pad area **2232** that is narrowed at the neck **2204** and tail **2206** to mechanically isolate the cable **4400** (FIGS. **44A-B**) from the remainder of the flex circuit **2200**. Further, the neck **2206** is folded (see FIG. **4**) for installation in the emitter pad **3000** (FIGS. **30A-H**) and acts as a flexible spring to further mechanically isolate the cable **4400** (FIGS. **44A-B**) from the emitter assembly **500** (FIG. **4**). The tail **2206** provides an integrated connectivity path between the detector assembly **2400** (FIG. **24**) mounted in the detector pad **3100** (FIGS. **31A-H**) and the cable connector **2230** mounted in the opposite emitter pad **3000** (FIGS. **30A-H**).

[0087] FIG. **23** illustrates the emitter portion of the flex circuit assembly **1900** (FIG. **21**) having the emitter assembly **500**. The emitter assembly connector **1530** is attached to the emitter end **2210** of the flex circuit **2200** (FIG. **22**). In particular, reflow solder **2330** connects thru hole pads **1532**, **1534** of the emitter assembly **500** to corresponding emitter pads **2310** of the flex circuit **2200** (FIG. **22**).

[0088] FIG. **24** illustrates a detector assembly **2400** including a detector **2410**, solder pads **2420**, copper mesh tape **2430**, an EMI shield **2440** and foil **2450**. The detector **2410** is soldered **2460** chip side down to detector solder pads **2420** of the flex circuit **2200**. The detector solder joint and detector ground pads **2420** are

wrapped with the Kapton tape **2470**. EMI shield tabs **2442** are folded onto the detector pads **2420** and soldered. The EMI shield walls are folded around the detector **2410** and the remaining tabs **2442** are soldered to the back of the EMI shield **2440**. The copper mesh tape **2430** is cut to size and the shielded detector and flex circuit solder joint are wrapped with the copper mesh tape **2430**. The foil **2450** is cut to size with a predetermined aperture **2452**. The foil **2450** is wrapped around shielded detector with the foil side in and the aperture **2452** is aligned with the EMI shield grid **2444**.

Detector Assembly

[0089] FIG. **25** illustrates an alternative detector assembly **2400** embodiment having adjacent detectors. Optical radiation having multiple wavelengths generated by emitters **700** is transmitted into a tissue site **1**. Optical radiation at a first set of wavelengths is detected by a first detector **2510**, such as, for example, a Si detector. Optical radiation at a second set of wavelengths is detected by a second detector **2520**, such as, for example, a GaAs detector.

[0090] FIG. **26** illustrates another alternative detector assembly **2400** embodiment having stacked detectors coaxial along a light path. Optical radiation having multiple wavelengths generated by emitters **700** is transmitted into a tissue site **1**. Optical radiation at a first set of wavelengths is detected by a first detector **2610**. Optical radiation at a second set of wavelengths passes through the first detector **2610** and is detected by a second detector **2620**. In a particular embodiment, a silicon (Si) detector and a gallium arsenide (GaAs) detector are used. The Si detector is placed on top of the GaAs detector so that light must pass through the Si detector before reaching the GaAs detector. The Si detector can be placed directly on top of the GaAs detector or the Si and GaAs detector can be separated by some other medium, such as a transparent medium or air. In another particular embodiment, a germanium detector is used instead of the GaAs detector. Advantageously, the stacked detector arrangement minimizes error caused by pathlength differences as compared with the adjacent detector embodiment.

Finger Clip

[0091] FIG. 27 illustrates a finger clip embodiment 2700 of a physiological sensor attachment assembly. The finger clip 2700 is configured to removably attach an emitter assembly 500 (FIG. 6) and detector assembly 2400 (FIG. 24), interconnected by a flex circuit assembly 1900, to a fingertip. The finger clip 2700 has an emitter shell 3800, an emitter pad 3000, a detector pad 2800 and a detector shell 3900. The emitter shell 3800 and the detector shell 3900 are rotatably connected and urged together by the spring assembly 3500. The emitter pad 3000 is fixedly retained by the emitter shell. The emitter assembly 500 (FIG. 6) is mounted proximate the emitter pad 3000 and adapted to transmit optical radiation having a plurality of wavelengths into fingertip tissue. The detector pad 2800 is fixedly retained by the detector shell 3900. The detector assembly 3500 is mounted proximate the detector pad 2800 and adapted to receive the optical radiation after attenuation by fingertip tissue.

[0092] FIG. 28 illustrates a detector pad 2800 advantageously configured to position and comfortably maintain a fingertip relative to a detector assembly for accurate sensor measurements. In particular, the detector pad has fingertip positioning features including a guide 2810, a contour 2820 and a stop 2830. The guide 2810 is raised from the pad surface 2803 and narrows as the guide 2810 extends from a first end 2801 to a second end 2802 so as to increasingly conform to a fingertip as a fingertip is inserted along the pad surface 2803 from the first end 2801. The contour 2820 has an indentation defined along the pad surface 2803 generally shaped to conform to a fingertip positioned over a detector aperture 2840 located within the contour 2820. The stop 2830 is raised from the pad surface 2803 so as to block the end of a finger from inserting beyond the second end 2802. FIGS. 29A-B illustrate detector pad embodiments 3100, 3400 each having a guide 2810, a contour 2820 and a stop 2830, described in further detail with respect to FIGS. 31 and 34, respectively.

[0093] FIGS. 30A-H illustrate an emitter pad 3000 having emitter pad flaps 3010, an emitter window 3020, mounting pins 3030, an emitter assembly cavity 3040,

isolation notches **3050**, a flex circuit notch **3070** and a cable notch **3080**. The emitter pad flaps **3010** overlap with detector pad flaps **3110** (FIGS. **31A-H**) to block ambient light. The emitter window **3020** provides an optical path from the emitter array **700** (FIG. **8**) to a tissue site. The mounting pins **3030** accommodate apertures in the flex circuit mounting ears **2214** (FIG. **22**), and the cavity **3040** accommodates the emitter assembly **500** (FIG. **21**). Isolation notches **3050** mechanically decouple the shell attachment **3060** from the remainder of the emitter pad **3000**. The flex circuit notch **3070** accommodates the flex circuit tail **2206** (FIG. **22**) routed to the detector pad **3100** (FIGS. **31A-H**). The cable notch **3080** accommodates the sensor cable **4400** (FIGS. **44A-B**). FIGS. **33A-H** illustrate an alternative slim finger emitter pad **3300** embodiment.

[0094] FIGS. **31A-H** illustrate a detector pad **3100** having detector pad flaps **3110**, a shoe box cavity **3120** and isolation notches **3150**. The detector pad flaps **3110** overlap with emitter pad flaps **3010** (FIGS. **30A-H**), interleaving to block ambient light. The shoe box cavity **3120** accommodates a shoe box **3200** (FIG. **32A-H**) described below. Isolation notches **3150** mechanically decouple the attachment points **3160** from the remainder of the detector pad **3100**. FIGS. **34A-H** illustrate an alternative slim finger detector pad **3400** embodiment.

[0095] FIGS. **32A-H** illustrate a shoe box **3200** that accommodates the detector assembly **2400** (FIG. **24**). A detector window **3210** provides an optical path from a tissue site to the detector **2410** (FIG. **24**). A flex circuit notch **3220** accommodates the flex circuit tail **2206** (FIG. **22**) routed from the emitter pad **3000** (FIGS. **30A-H**). In one embodiment, the shoe box **3200** is colored black or other substantially light absorbing color and the emitter pad **3000** and detector pad **3100** are each colored white or other substantially light reflecting color.

[0096] FIGS. **35-37** illustrate a spring assembly **3500** having a spring **3600** configured to urge together an emitter shell **3800** (FIG. **46**) and a detector shell **3900**. The detector shell is rotatably connected to the emitter shell. The spring is disposed between the shells **3800**, **3900** and adapted to create a pivot point along a finger gripped between the shells that is substantially behind the fingertip. This

advantageously allows the shell hinge **3810, 3910** (FIGS. **38-39**) to expand so as to distribute finger clip force along the inserted finger, comfortably keeping the fingertip in position over the detector without excessive force.

[0097] As shown in FIGS **36A-C**, the spring **3600** has coils **3610**, an emitter shell leg **3620** and a detector shell leg **3630**. The emitter shell leg **3620** presses against the emitter shell **3800** (FIGS. **38A-D**) proximate a grip **3820** (FIGS. **38A-D**). The detector shell legs **3630** extend along the detector shell **3900** (FIGS. **39A-D**) to a spring plate **3700** (FIGS. **37A-D**) attachment point. The coil **3610** is secured by hinge pins **410** (FIG. **46**) and is configured to wind as the finger clip is opened, reducing its diameter and stress accordingly.

[0098] As shown in FIGS. **37A-D** the spring plate **3700** has attachment apertures **3710**, spring leg slots **3720**, and a shelf **3730**. The attachment apertures **3710** accept corresponding shell posts **3930** (FIGS. **39A-D**) so as to secure the spring plate **3700** to the detector shell **3900** (FIG. **39A-D**). Spring legs **3630** (FIG. **36A-C**) are slidably anchored to the detector shell **3900** (FIG. **39A-D**) by the shelf **3730**, advantageously allowing the combination of spring **3600**, shells **3800, 3900** and hinges **3810, 3910** to adjust to various finger sizes and shapes.

[0099] FIGS. **38-39** illustrate the emitter and detector shells **3800, 3900**, respectively, having hinges **3810, 3910** and grips **3820, 3920**. Hinge apertures **3812, 3912** accept hinge pins **410** (FIG. **46**) so as to create a finger clip. The detector shell hinge aperture **3912** is elongated, allowing the hinge to expand to accommodate a finger.

Monitor And Sensor

[0100] FIG. **40** illustrates a monitor **100** and a corresponding sensor assembly **200**, as described generally with respect to FIGS. **1-3**, above. The sensor assembly **200** has a sensor **400** and a sensor cable **4400**. The sensor **400** houses an emitter assembly **500** having emitters responsive to drivers within a sensor controller **4500** so as to transmit optical radiation into a tissue site. The sensor **400** also houses a detector assembly **2400** that provides a sensor signal **2500** responsive to the optical radiation after tissue attenuation. The sensor signal **2500** is filtered, amplified,

sampled and digitized by the front-end **4030** and input to a DSP (digital signal processor) **4040**, which also commands the sensor controller **4500**. The sensor cable **4400** electrically communicates drive signals from the sensor controller **4500** to the emitter assembly **500** and a sensor signal **2500** from the detector assembly **2400** to the front-end **4030**. The sensor cable **4400** has a monitor connector **210** that plugs into a monitor sensor port **110**.

[0101] In one embodiment, the monitor **100** also has a reader **4020** capable of obtaining information from an information element (IE) in the sensor assembly **200** and transferring that information to the DSP **4040**, to another processor or component within the monitor **100**, or to an external component or device that is at least temporarily in communication with the monitor **100**. In an alternative embodiment, the reader function is incorporated within the DSP **4040**, utilizing one or more of DSP I/O, ADC, DAC features and corresponding processing routines, as examples.

[0102] In one embodiment, the monitor connector **210** houses the information element **4000**, which may be a memory device or other active or passive electrical component. In a particular embodiment, the information element **4000** is an EPROM, or other programmable memory, or an EEPROM, or other reprogrammable memory, or both. In an alternative embodiment, the information element **4000** is housed within the sensor **400**, or an information element **4000** is housed within both the monitor connector **4000** and the sensor **400**. In yet another embodiment, the emitter assembly **500** has an information element **4000**, which is read in response to one or more drive signals from the sensor controller **4500**, as described with respect to FIGS. **41-43**, below. In a further embodiment, a memory information element is incorporated into the emitter array **700** (FIG. **8**) and has characterization information relating to the LEDs **801** (FIG. **8**). In one advantageous embodiment, trend data relating to slowly varying parameters, such as perfusion index, HbCO or METHb, to name a few, are stored in an IE memory device, such as EEPROM.

Back-to-Back LEDs

[0103] FIGS. **41-43** illustrate alternative sensor embodiments. A sensor controller **4500** configured to activate an emitter array **700** (FIG. **7**) arranged in an electrical grid, is described with respect to FIG. **7**, above. Advantageously, a sensor controller **4500** so configured is also capable of driving a conventional two-wavelength (red and IR) sensor **4100** having back-to-back LEDs **4110**, **4120** or an information element **4300** or both.

[0104] FIG. **41A** illustrates a sensor **4100** having an electrical grid **4130** configured to activate light emitting sources by addressing at least one row conductor and at least one column conductor. A first LED **4110** and a second LED **4120** are configured in a back-to-back arrangement so that a first contact **4152** is connected to a first LED **4110** cathode and a second LED **4120** anode and a second contact **4154** is connected to a first LED **4110** anode and a second LED **4120** cathode. The first contact **4152** is in communications with a first row conductor **4132** and a first column conductor **4134**. The second contact is in communications with a second row conductor **4136** and a second column conductor **4138**. The first LED **4110** is activated by addressing the first row conductor **4132** and the second column conductor **4138**. The second LED **4120** is activated by addressing the second row conductor **4136** and the first column conductor **4134**.

[0105] FIG. **41B** illustrates a sensor cable **4400** embodiment capable of communicating signals between a monitor **100** and a sensor **4100**. The cable **4400** has a first row input **4132**, a first column input **4134**, a second row input **4136** and a second column input **4138**. A first output **4152** combines the first row input **4132** and the first column input **4134**. A second output **4154** combines a second row input **4136** and second column input **4138**.

[0106] FIG. **41C** illustrates a monitor **100** capable of communicating drive signals to a sensor **4100**. The monitor **4400** has a first row signal **4132**, a first column signal **4134**, a second row signal **4136** and a second column signal **4138**. A first output signal **4152** combines the first row signal **4132** and the first column signal

4134. A second output signal **4154** combines a second row signal **4136** and second column signal **4138**.

Information Elements

[0107] FIGS. **42-43** illustrate information element **4200-4300** embodiments in communications with emitter array drivers configured to activate light emitters connected in an electrical grid. The information elements are configured to provide information as DC values, AC values or a combination of DC and AC values in response corresponding DC, AC or combination DC and AC electrical grid drive signals. FIG. **42** illustrates information element embodiment **4200** advantageously driven directly by an electrical grid having rows **710** and columns **720**. In particular, the information element **4200** has a series connected resistor R_2 **4210** and diode **4220** connected between a row line **710** and a column line **720** of an electrical grid. In this manner, the resistor R_2 value can be read in a similar manner that LEDs **810** (FIG. **8**) are activated. The diode **4220** is oriented, e.g. anode to row and cathode to column as the LEDs so as to prevent parasitic currents from unwanted activation of LEDs **810** (FIG. **8**).

[0108] FIGS. **43A-C** illustrate other embodiments where the value of R_1 is read with a DC grid drive current and a corresponding grid output voltage level. In other particular embodiments, the combined values of R_1 , R_2 and C or, alternatively, R_1 , R_2 and L are read with a varying (AC) grid drive currents and a corresponding grid output voltage waveform. As one example, a step in grid drive current is used to determine component values from the time constant of a corresponding rise in grid voltage. As another example, a sinusoidal grid drive current is used to determine component values from the magnitude or phase or both of a corresponding sinusoidal grid voltage. The component values determined by DC or AC electrical grid drive currents can represent sensor types, authorized suppliers or manufacturers, emitter wavelengths among others. Further, a diode D (FIG. **43C**) can be used to provide one information element reading R_1 at one drive level or polarity and another information element reading, combining R_1 and R_2 , at a second drive level or polarity, i.e. when the diode is forward biased.

[0109] Passive information element **4300** embodiments may include any of various combinations of resistors, capacitors or inductors connected in series and parallel, for example. Other information element **4300** embodiments connected to an electrical grid and read utilizing emitter array drivers incorporate other passive components, active components or memory components, alone or in combination, including transistor networks, PROMs, ROMs, EPROMs, EEPROMs, gate arrays and PLAs to name a few.

Sensor Cable

[0110] FIGS. **44A-B** illustrate a sensor cable **4400** having an outer jacket **4410**, an outer shield **4420**, multiple outer wires **4430**, an inner jacket **4440**, an inner shield **4450**, a conductive polymer **4460** and an inner twisted wire pair **4470**. The outer wires **4430** are advantageously configured to compactly carry multiple drive signals to the emitter array **700** (FIG. 7). In one embodiment, there are twelve outer wires **4430** corresponding to four anode drive signals **4501** (FIG. 45), four cathode drive signals **4502** (FIG. 45), two thermistor pinouts **1450** (FIG. 15) and two spares. The inner twisted wire pair **4470** corresponds to the sensor signal **2500** (FIG. 25) and is extruded within the conductive polymer **4460** so as to reduce triboelectric noise. The shields **4420**, **4450** and the twisted pair **4470** boost EMI and crosstalk immunity for the sensor signal **2500** (FIG. 25).

Controller

[0111] FIG. 45 illustrates a sensor controller **4500** located in the monitor **100** (FIG. 1) and configured to provide anode drive signals **4501** and cathode drive signals **4502** to the emitter array **700** (FIG. 7). The DSP (digital signal processor) **4040**, which performs signal processing functions for the monitor, also provides commands **4042** to the sensor controller **4500**. These commands determine drive signal **4501**, **4502** levels and timing. The sensor controller **4500** has a command register **4510**, an anode selector **4520**, anode drivers **4530**, current DACs (digital-to-analog converters) **4540**, a current multiplexer **4550**, cathode drivers **4560**, a current meter **4570** and a current limiter **4580**. The command register **4510** provides

control signals responsive to the DSP commands **4042**. In one embodiment, the command register **4510** is a shift register that loads serial command data **4042** from the DSP **4040** and synchronously sets output bits that select or enable various functions within the sensor controller **4500**, as described below.

[0112] As shown in FIG. **45**, the anode selector **4520** is responsive to anode select **4516** inputs from the command register **4510** that determine which emitter array row **810** (FIG. **8**) is active. Accordingly, the anode selector **4520** sets one of the anode on **4522** outputs to the anode drivers **4530**, which pulls up to Vcc one of the anode outputs **4501** to the emitter array **700** (FIG. **8**).

[0113] Also shown in FIG. **45**, the current DACs **4540** are responsive to command register data **4519** that determines the currents through each emitter array column **820** (FIG. **8**). In one embodiment, there are four, 12-bit DACs associated with each emitter array column **820** (FIG. **8**), sixteen DACs in total. That is, there are four DAC outputs **4542** associated with each emitter array column **820** (FIG. **8**) corresponding to the currents associated with each row **810** (FIG. **8**) along that column **820** (FIG. **8**). In a particular embodiment, all sixteen DACs **4540** are organized as a single shift register, and the command register **4510** serially clocks DAC data **4519** into the DACs **4540**. A current multiplexer **4550** is responsive to cathode on **4518** inputs from the command register **4510** and anode on **4522** inputs from the anode selector **4520** so as to convert the appropriate DAC outputs **4542** to current set **4552** inputs to the cathode drivers **4560**. The cathode drivers **4560** are responsive to the current set **4552** inputs to pull down to ground one to four of the cathode outputs **4502** to the emitter array **700** (FIG. **8**).

[0114] The current meter **4570** outputs a current measure **4572** that indicates the total LED current driving the emitter array **700** (FIG. **8**). The current limiter **4580** is responsive to the current measure **4572** and limits specified by the command register **4510** so as to prevent excessive power dissipation by the emitter array **700** (FIG. **8**). The current limiter **4580** provides an enable **4582** output to the anode selector **4520**. A Hi Limit **4512** input specifies the higher of two preset current limits. The current limiter **4580** latches the enable **4582** output in an off condition when the

current limit is exceeded, disabling the anode selector **4520**. A trip reset **4514** input resets the enable **4582** output to re-enable the anode selector **4520**.

Sensor Assembly

[0115] As shown in FIG. **46**, the sensor **400** has an emitter shell **3800**, an emitter pad **3000**, a flex circuit assembly **2200**, a detector pad **3100** and a detector shell **3900**. A sensor cable **4400** attaches to the flex circuit assembly **2200**, which includes a flex circuit **2100**, an emitter assembly **500** and a detector assembly **2400**. The portion of the flex circuit assembly **2200** having the sensor cable **4400** attachment and emitter assembly **500** is housed by the emitter shell **3800** and emitter pad **3000**. The portion of the flex circuit assembly **2200** having the detector assembly **2400** is housed by the detector shell **3900** and detector pad **3100**. In particular, the detector assembly **2400** inserts into a shoe **3200**, and the shoe **3200** inserts into the detector pad **3100**. The emitter shell **3800** and detector shell **3900** are fastened by and rotate about hinge pins **410**, which insert through coils of a spring **3600**. The spring **3600** is held to the detector shell **3900** with a spring plate **3700**. A finger stop **450** attaches to the detector shell. In one embodiment, a silicon adhesive **420** is used to attach the pads **3000**, **3100** to the shells **3800**, **3900**, a silicon potting compound **430** is used to secure the emitter and detector assemblies **500**, **2400** within the pads **3000**, **3100**, and a cyanoacrylic adhesive **440** secures the sensor cable **4400** to the emitter shell **3800**.

[0116] A multiple wavelength sensor has been disclosed in detail in connection with various embodiments. These embodiments are disclosed by way of examples only and are not to limit the scope of the claims that follow. One of ordinary skill in art will appreciate many variations and modifications.

WHAT IS CLAIMED IS:

1. A physiological sensor comprising:
a plurality of emitters configured to transmit optical radiation having a plurality of wavelengths in response to a corresponding plurality of drive currents;
a thermal mass disposed proximate the emitters so as to stabilize a bulk temperature for the emitters; and
a temperature sensor thermally coupled to the thermal mass,
wherein the temperature sensor provides a temperature sensor output responsive to the bulk temperature so that the wavelengths are determinable as a function of the drive currents and the bulk temperature.

2. The physiological sensor according to claim 1 further comprising a substrate having a first side and a second side,
wherein the emitters are mounted to the first side, and
wherein the temperature sensor is mounted to the second side.

3. The physiological sensor according to claim 2 wherein the temperature sensor is a thermistor and the emitters are LEDs.

4. The physiological sensor according to claim 3:
wherein the thermal mass is a plurality of layers of the substrate, and
wherein each of the layers is substantially copper clad.

5. A physiological sensor capable of emitting light into tissue and producing an output signal usable to determine one or more physiological parameters of a patient, the physiological sensor comprising:

a thermal mass;

a plurality of light emitting sources thermally coupled to the thermal mass, the sources having a corresponding plurality of operating wavelengths;

a temperature sensor thermally coupled to the thermal mass and capable of determining a bulk temperature for the thermal mass, the operating wavelengths dependent on the bulk temperature; and

a detector capable of detecting light emitted by the light emitting sources after tissue attenuation, wherein the detector is capable of outputting a signal usable to determine one or more physiological parameters of a patient based upon the operating wavelengths.

6. The physiological sensor according to claim 5:

wherein the light emitting sources and the temperature sensor are disposed on a substrate, and

wherein the thermal mass is disposed within the substrate proximate the light emitting sources and the temperature sensor.

7. The physiological sensor according to claim 6 wherein the temperature sensor comprises a thermistor.

8. The physiological sensor according to claim 7 wherein the light emitting sources are disposed on a first side of the substrate and the temperature sensor is disposed on a second side of the substrate.

9. In a physiological sensor adapted to determine a physiological parameter using a plurality of light emitting sources with emission wavelengths affected by one or more dynamic operating parameters, a sensor method comprising:

transmitting optical radiation from the plurality of light emitting sources into body tissue;

detecting the optical radiation after tissue attenuation; and

determining a plurality of operating wavelengths of the light emitting sources dependent on a bulk temperature of the light emitting sources so that one or more physiological parameters of a patient can be determined based upon the operating wavelengths.

10. The physiological sensor method according to claim 9 wherein the determining step comprises stabilizing the bulk temperature for the light emitting sources.

11. The physiological sensor method according to claim 10 wherein the determining further comprises thermally coupling a thermistor to the light emitting sources so as to indicate the bulk temperature.

12. The physiological sensor method according to claim 11 further comprising disposing the thermistor proximate the light emitting sources.

13. In a physiological sensor adapted to determine a physiological parameter using a plurality of light emitting sources with emission wavelengths affected by one or more dynamic operating parameters, a sensor method comprising:

transmitting optical radiation from the plurality of light emitting sources into body tissue;

detecting the optical radiation after tissue attenuation; and

indicating an operating wavelength for each of the plurality of light emitting sources.

14. The physiological sensor method according to claim 13 wherein the indicating step comprises measuring a bulk temperature for the light emitting sources.

15. The physiological sensor method according to claim 14 wherein the indicating further comprises utilizing a thermistor thermally coupled to the light emitting sources so as to measure a bulk temperature.

MULTIPLE WAVELENGTH SENSOR SUBSTRATE

ABSTRACT OF THE DISCLOSURE

A physiological sensor has emitters configured to transmit optical radiation having multiple wavelengths in response to corresponding drive currents. A thermal mass is disposed proximate the emitters so as to stabilize a bulk temperature for the emitters. A temperature sensor is thermally coupled to the thermal mass. The temperature sensor provides a temperature sensor output responsive to the bulk temperature so that the wavelengths are determinable as a function of the drive currents and the bulk temperature.

2409918
030106

1/18

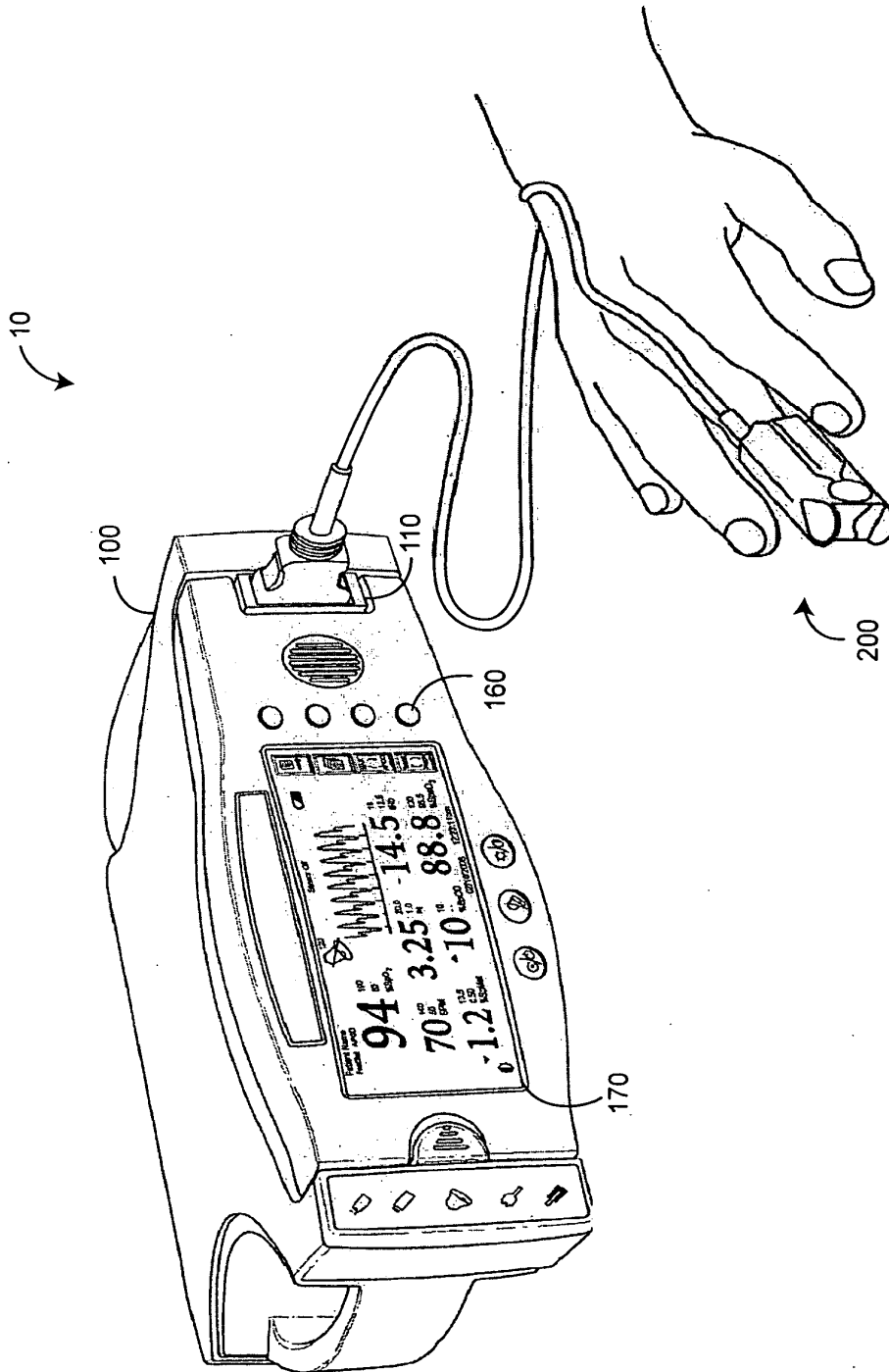

FIG. 1

BEST AVAILABLE COPY

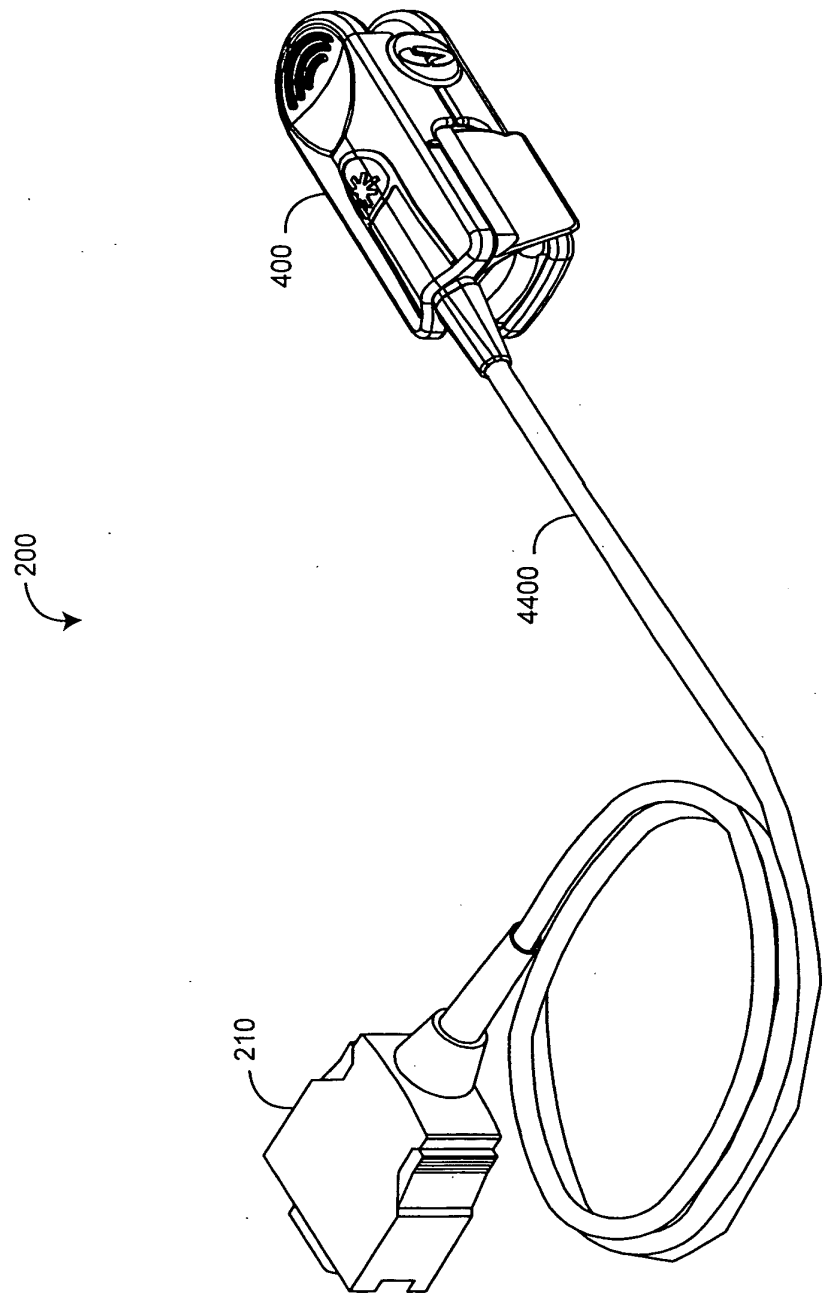

FIG. 2A

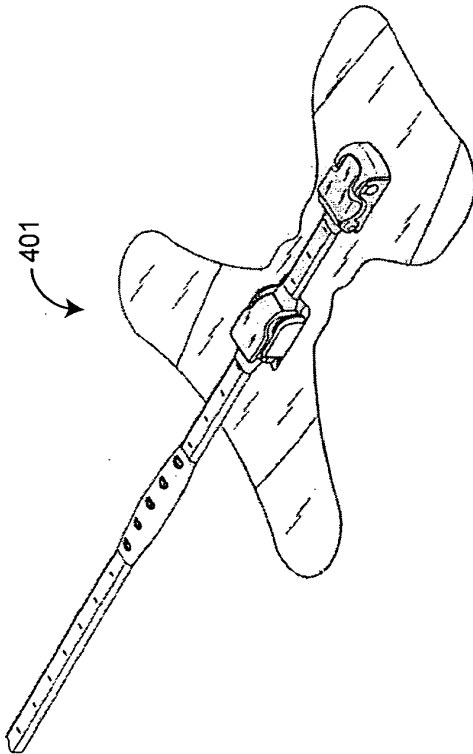

FIG. 2B

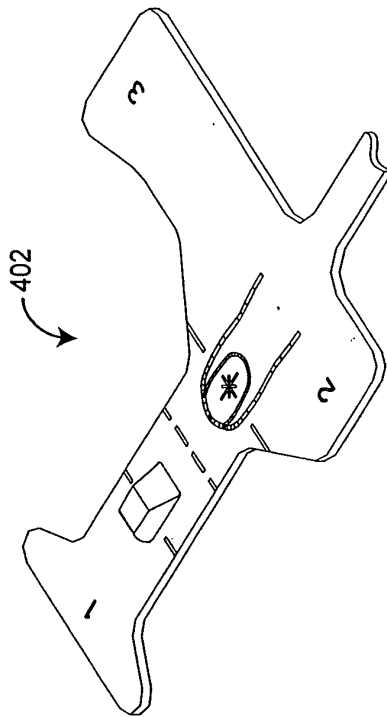

FIG. 2C

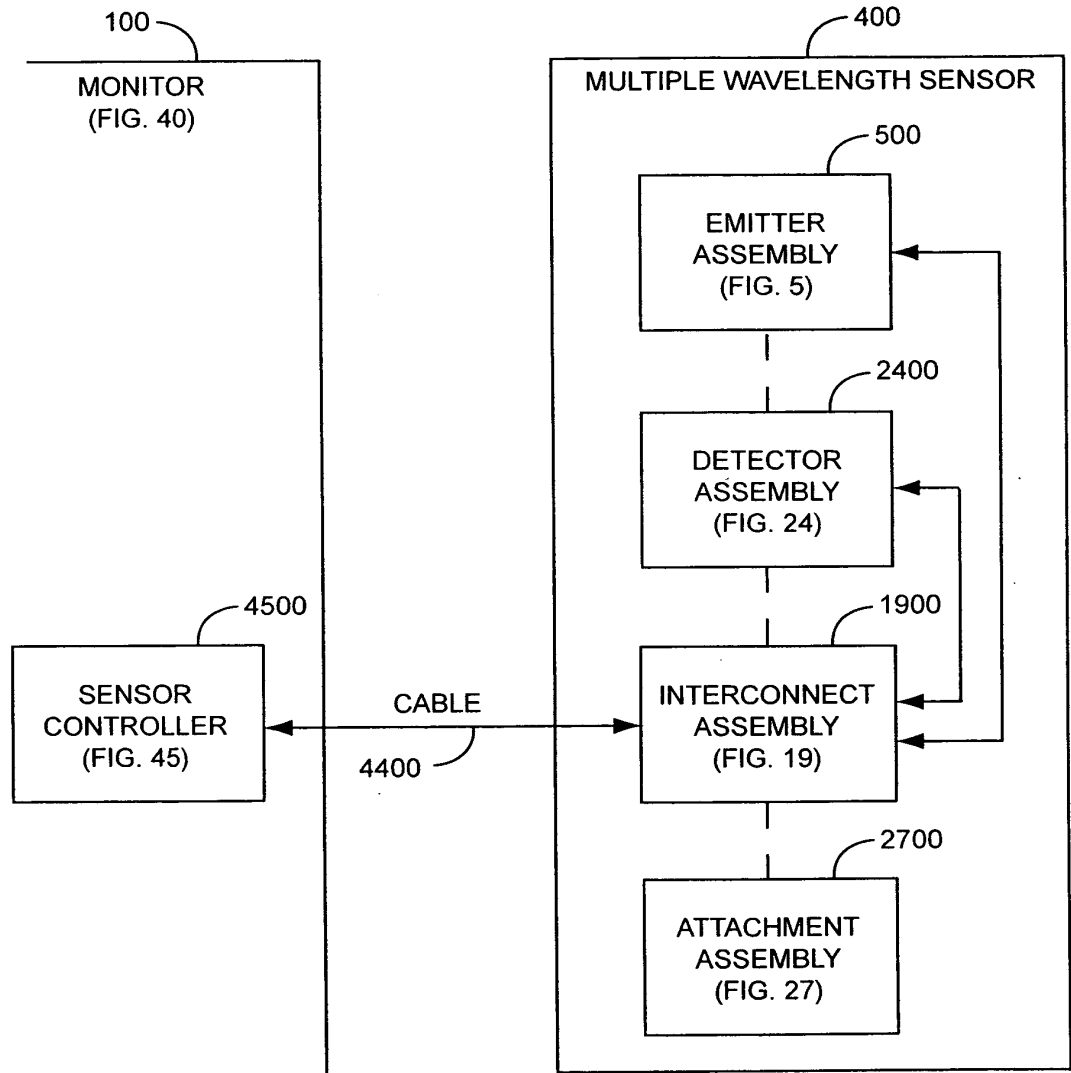

FIG. 3

MULTIPLE WAVELENGTH SENSOR SUBSTRATE
Ammar Al-Ali et al.
Appl. No.: Unknown Atty Docket: MLR.004A

5/48

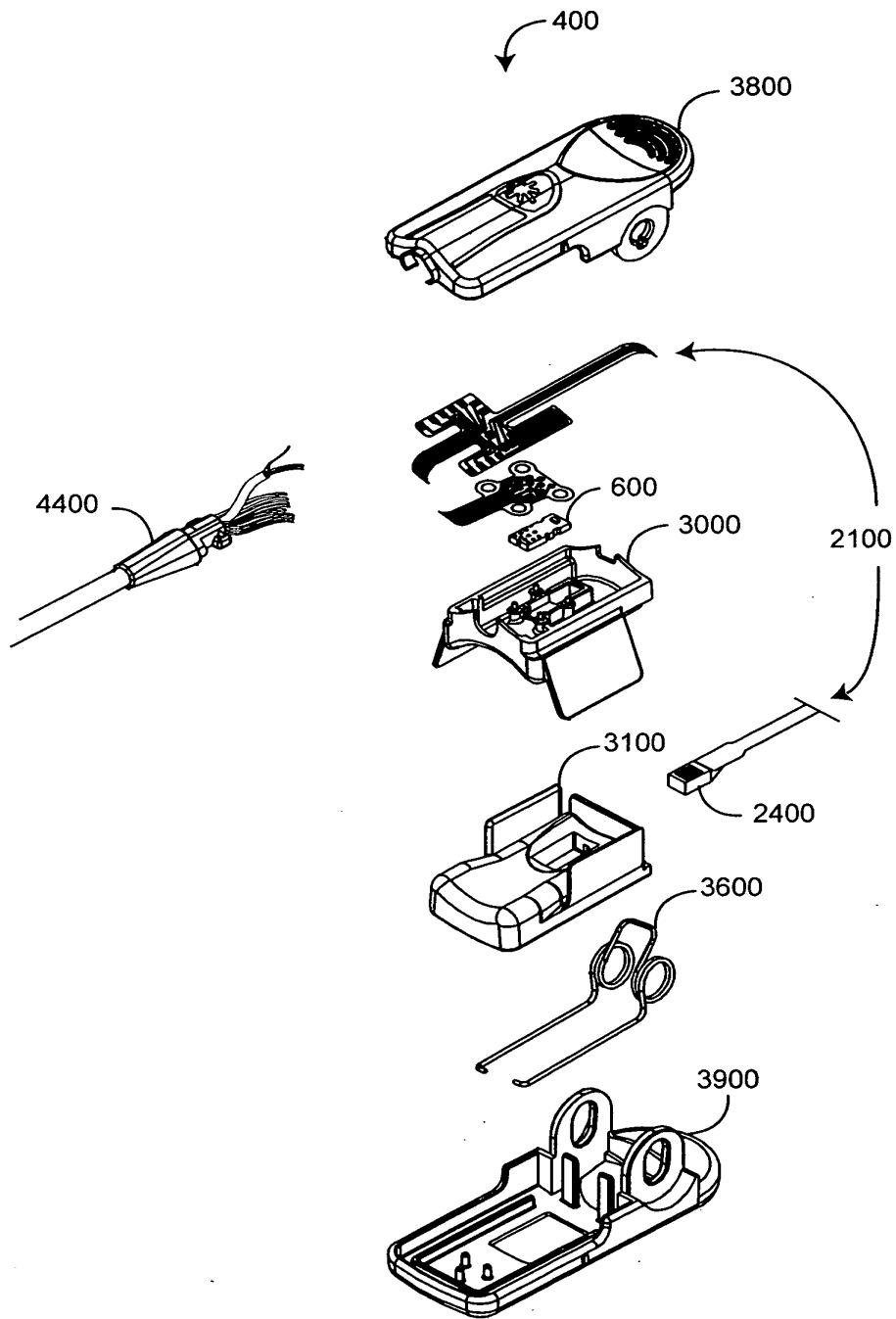

FIG. 4

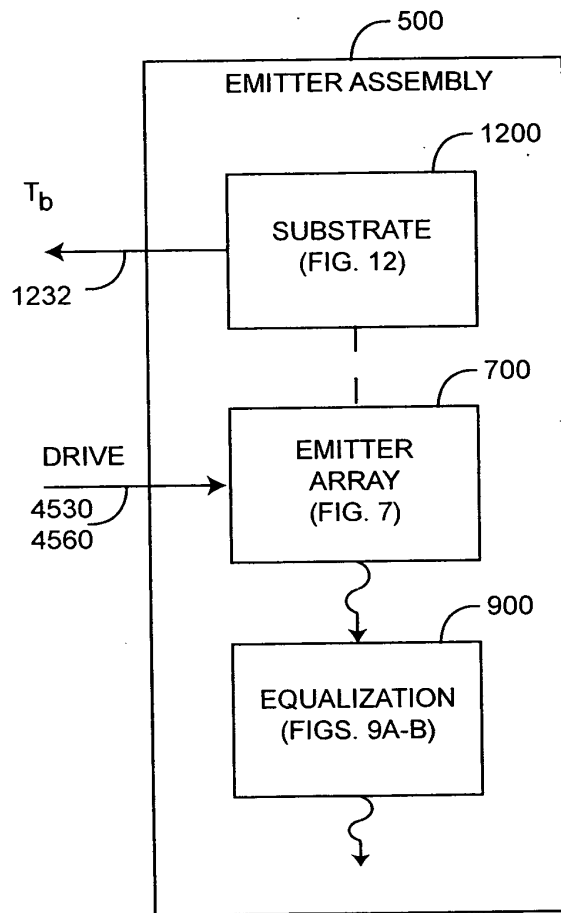

FIG. 5

7/48

500

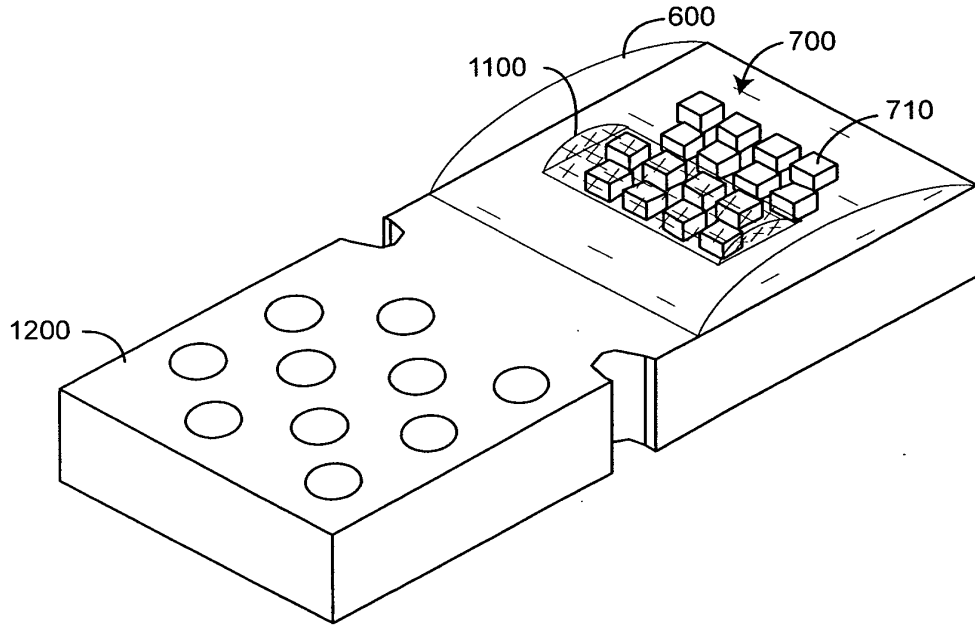

FIG. 6

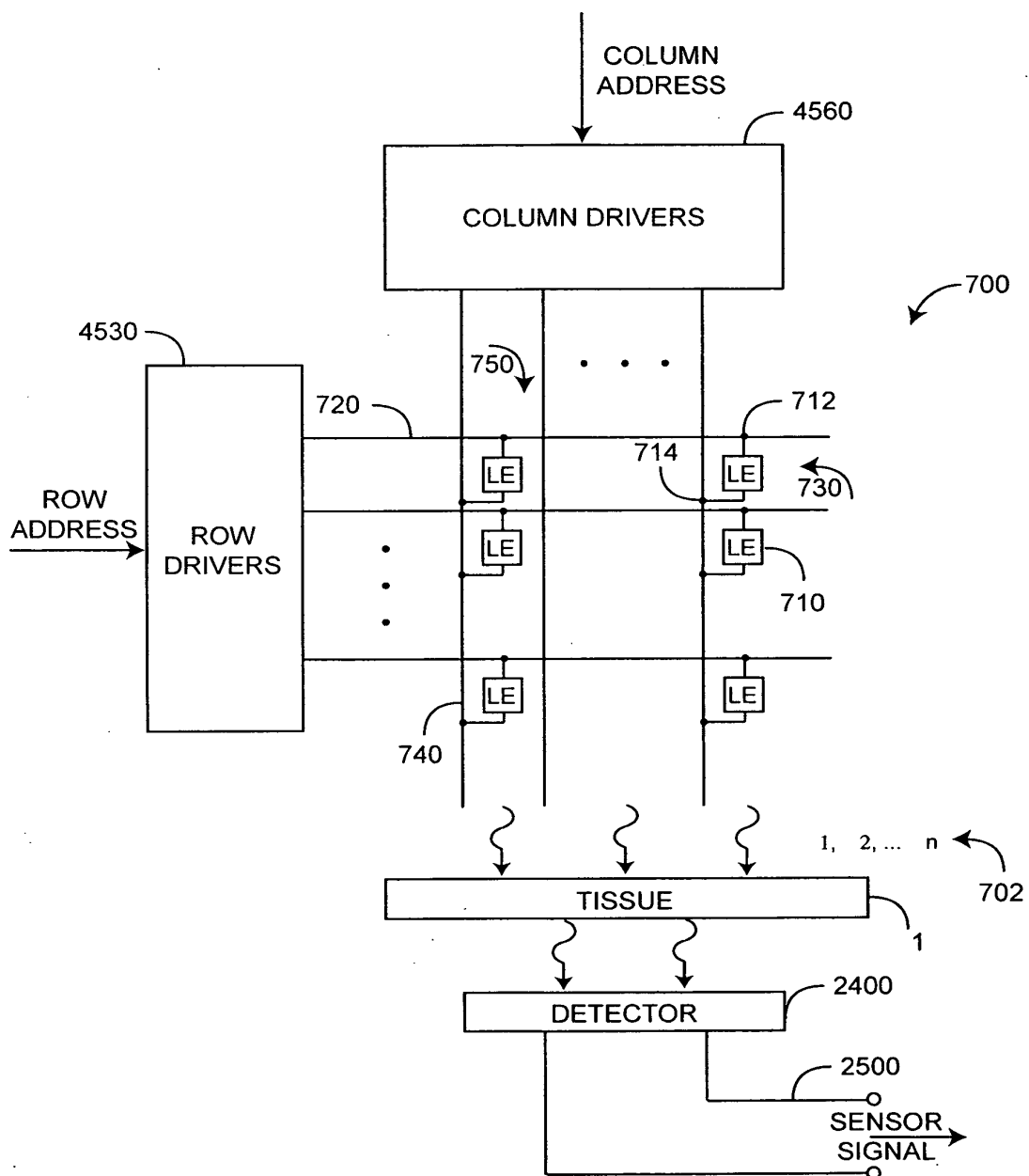

FIG. 7

9/48

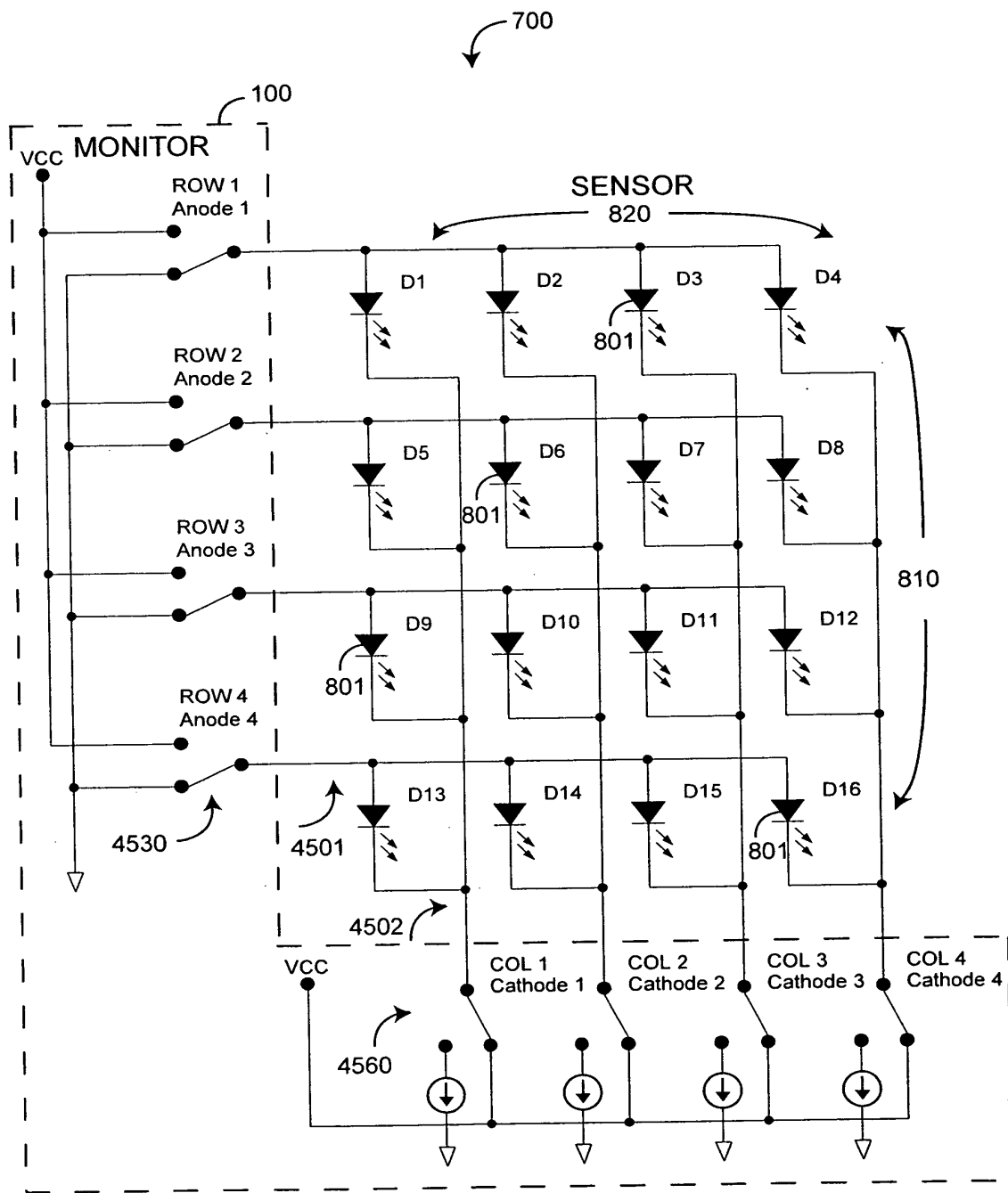

FIG. 8

10/48

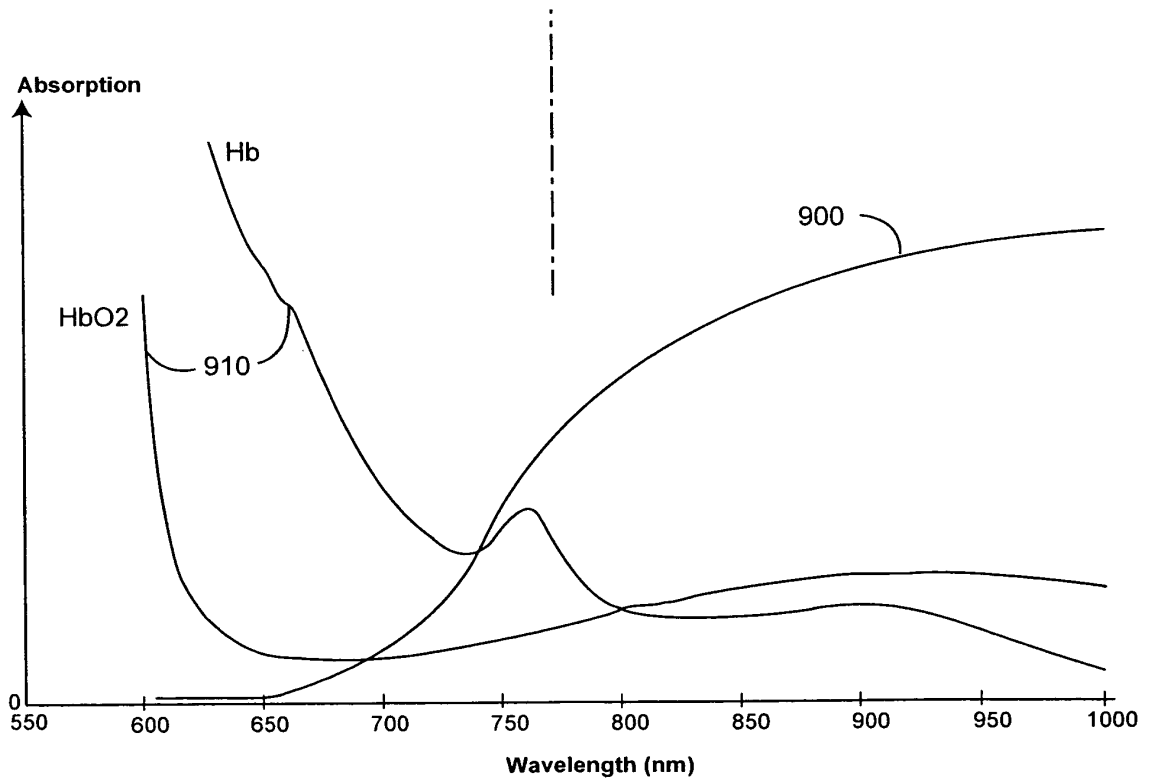
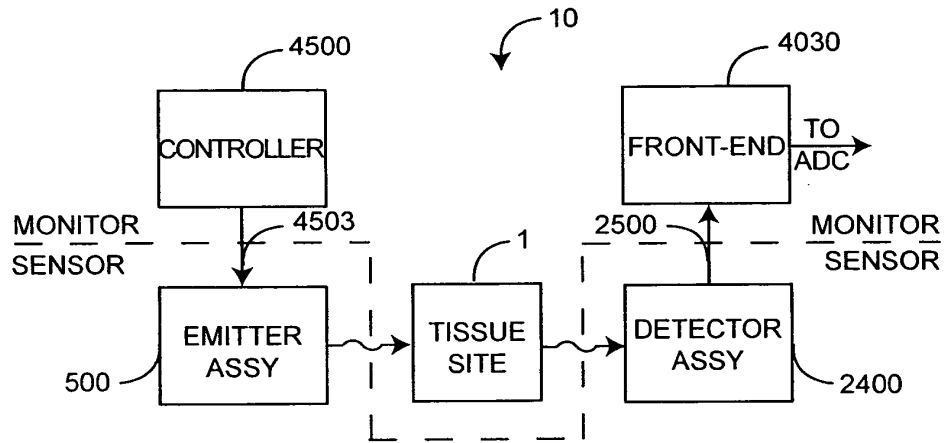

FIG. 9

11/48

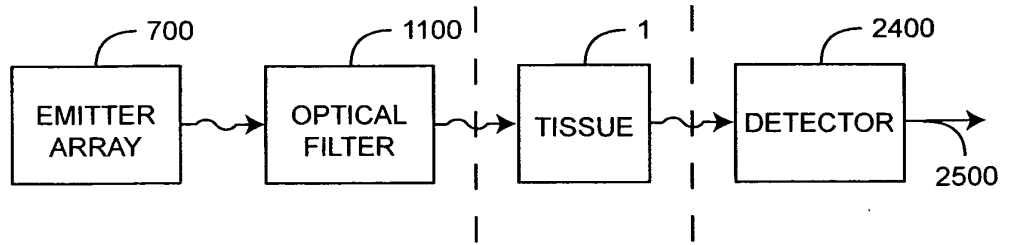

FIG. 10A

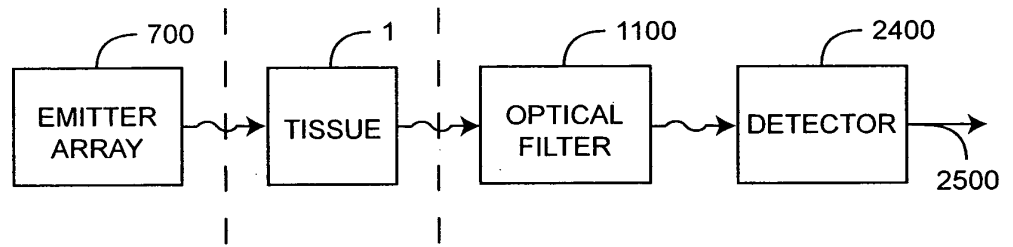

FIG. 10B

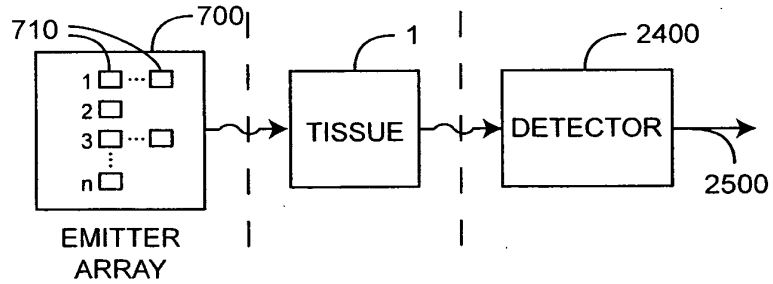

FIG. 10C

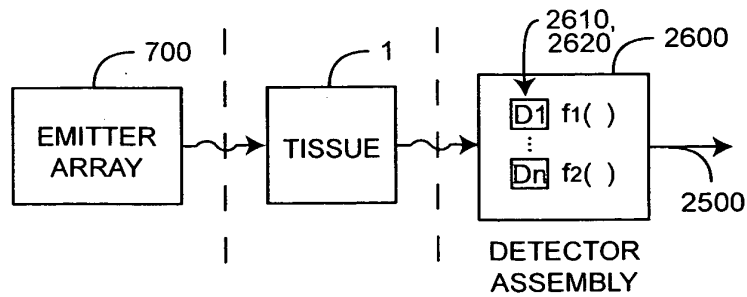

FIG. 10D

12/48

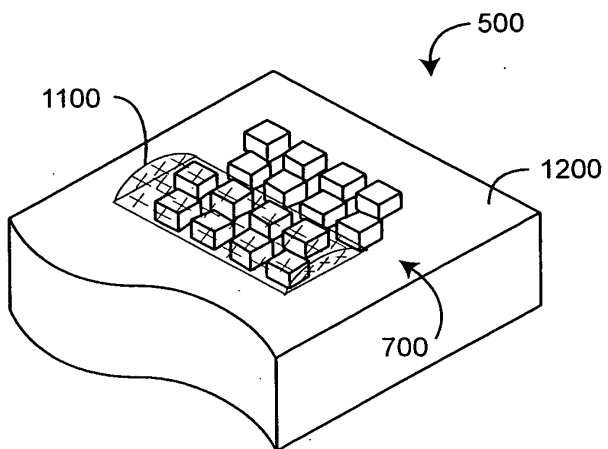

FIG. 11A

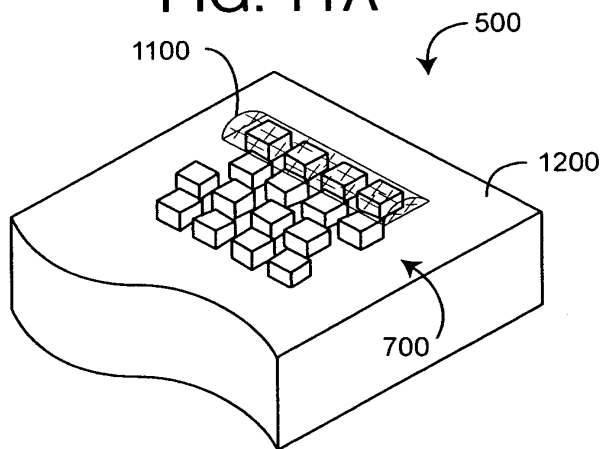

FIG. 11B

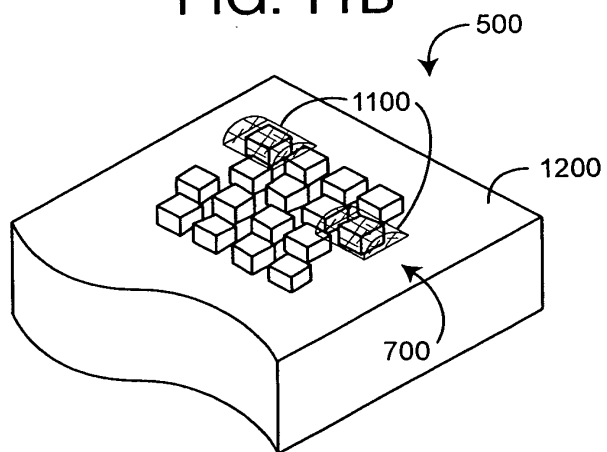

FIG. 11C

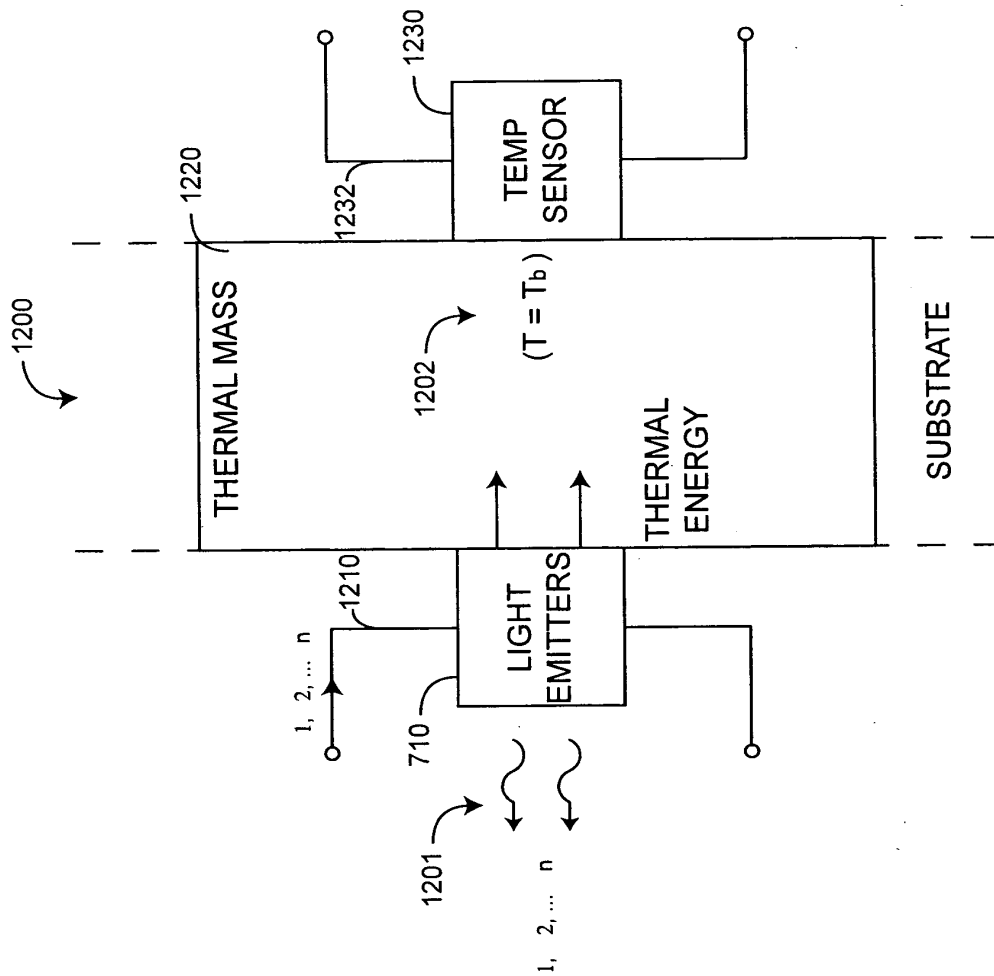
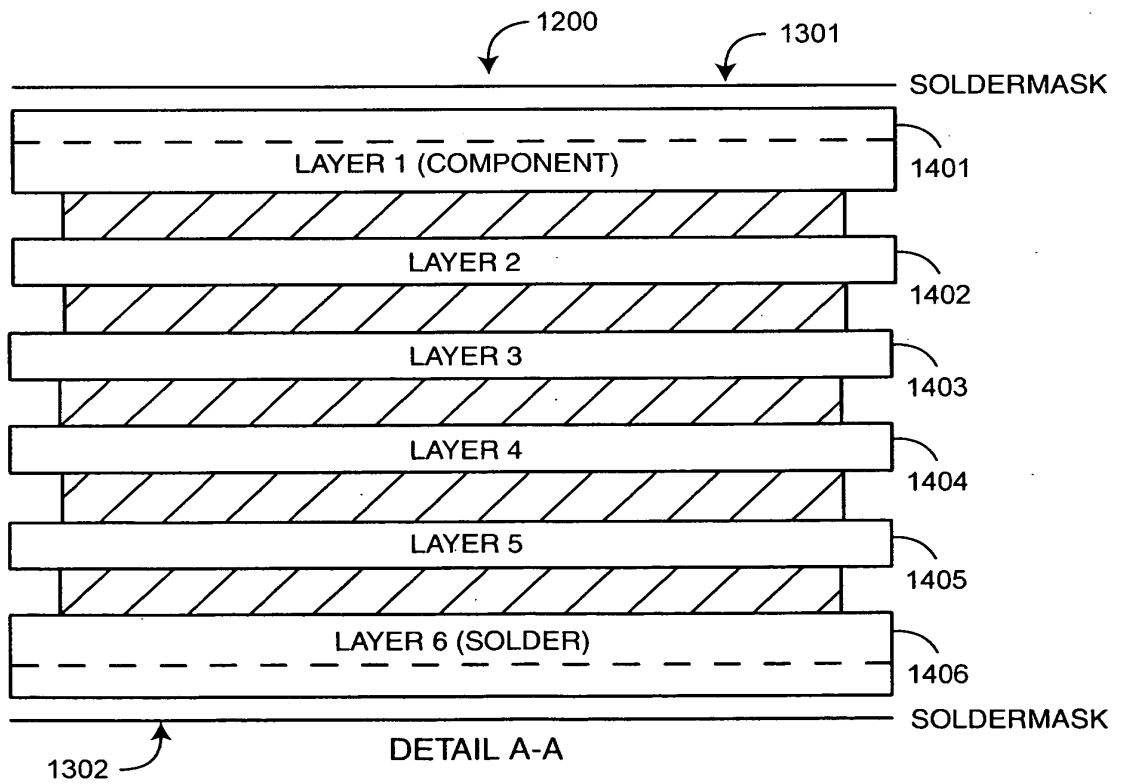
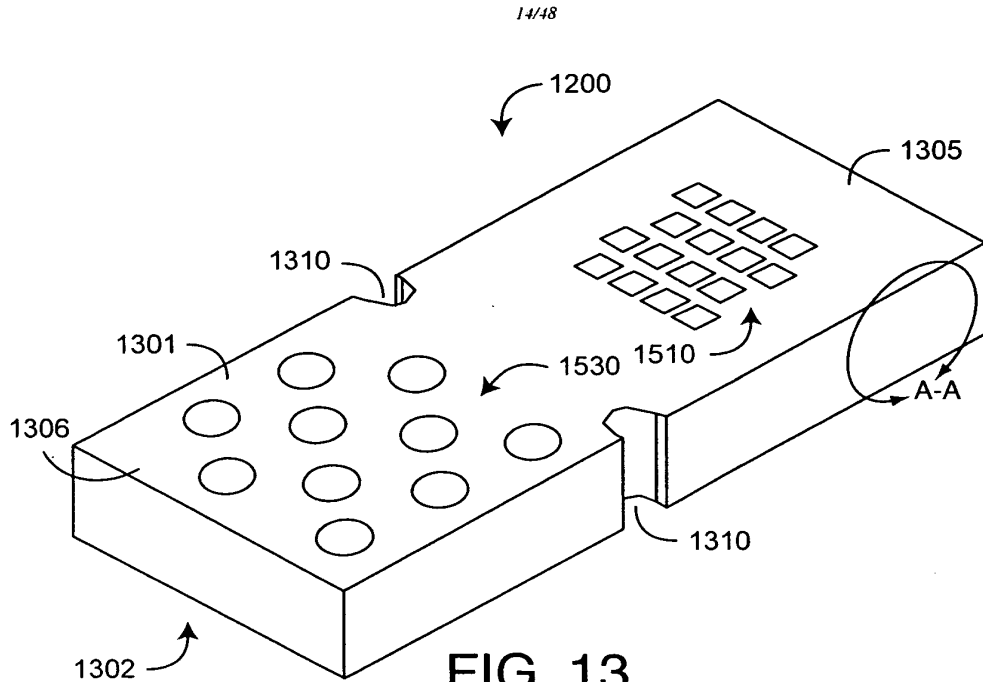

FIG. 12



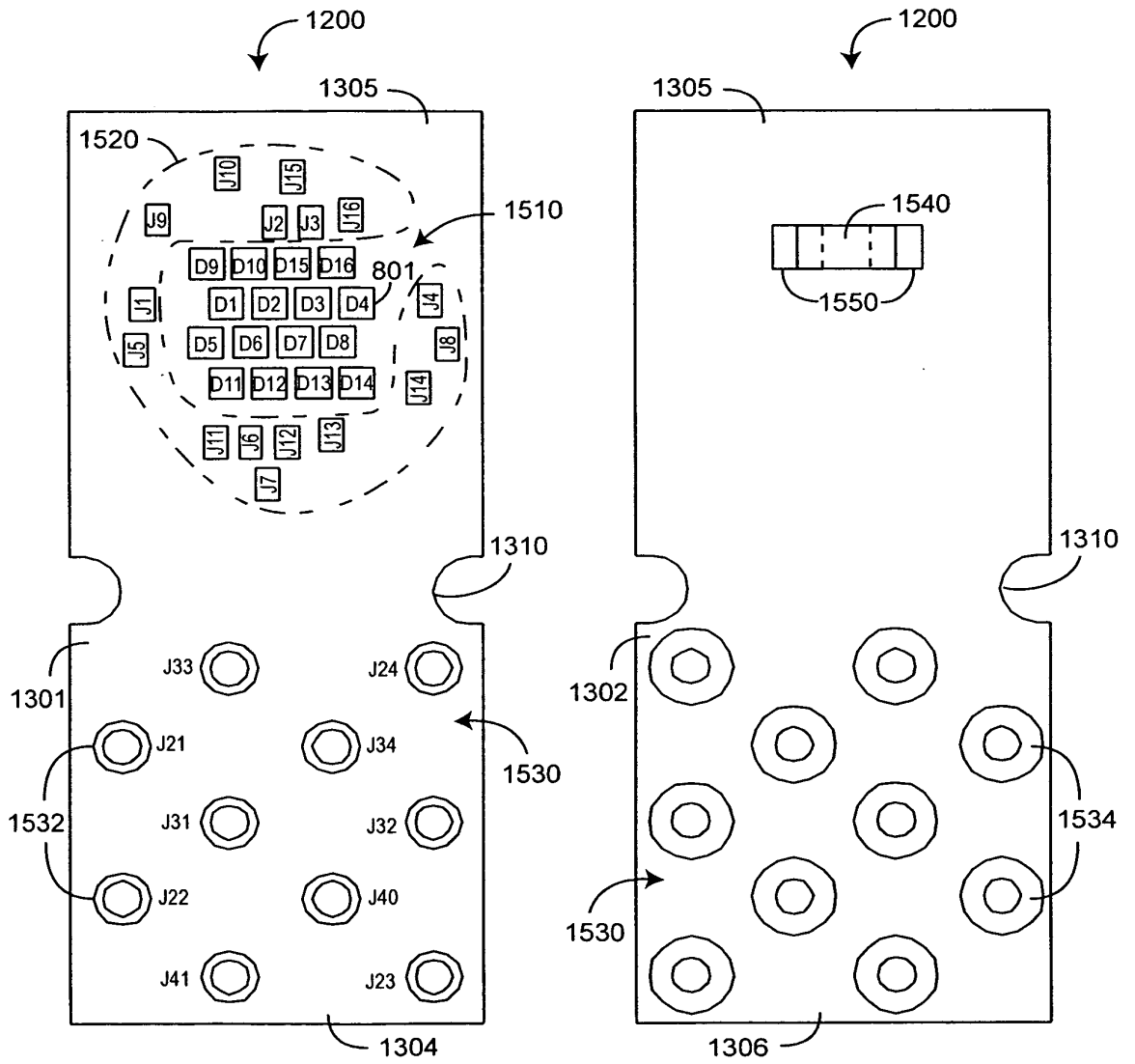

FIG. 15

FIG. 16

MULTIPLE WAVELENGTH SENSOR SUBSTRATE
 Ammar Al-Ali et al.
 Appl. No.: Unknown Atty Docket: MLR.004A

16-48

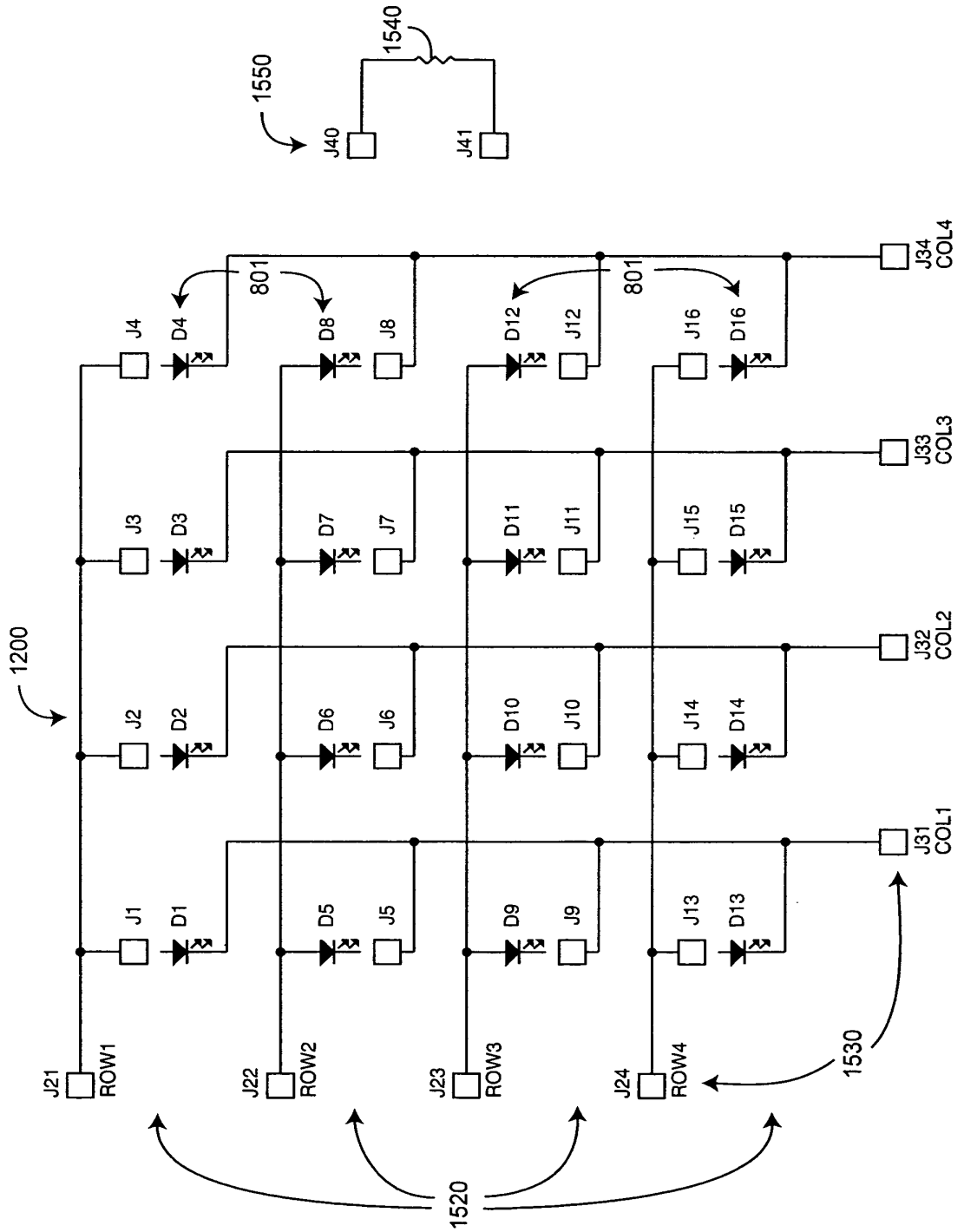

FIG. 17

17/48

1402

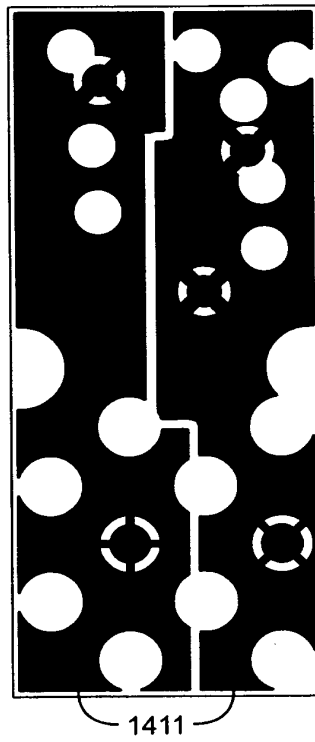

FIG. 18

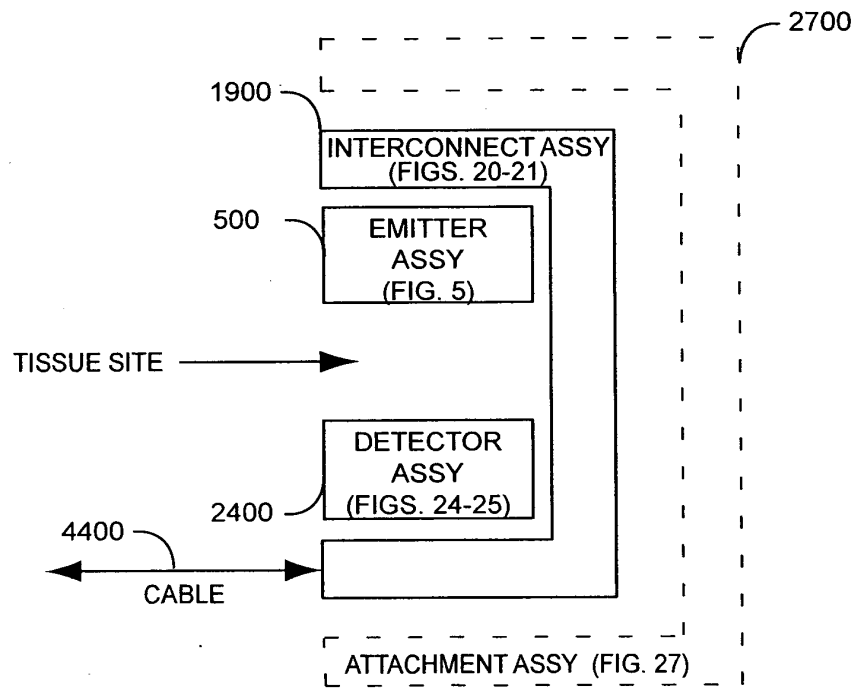

FIG. 19

19/48

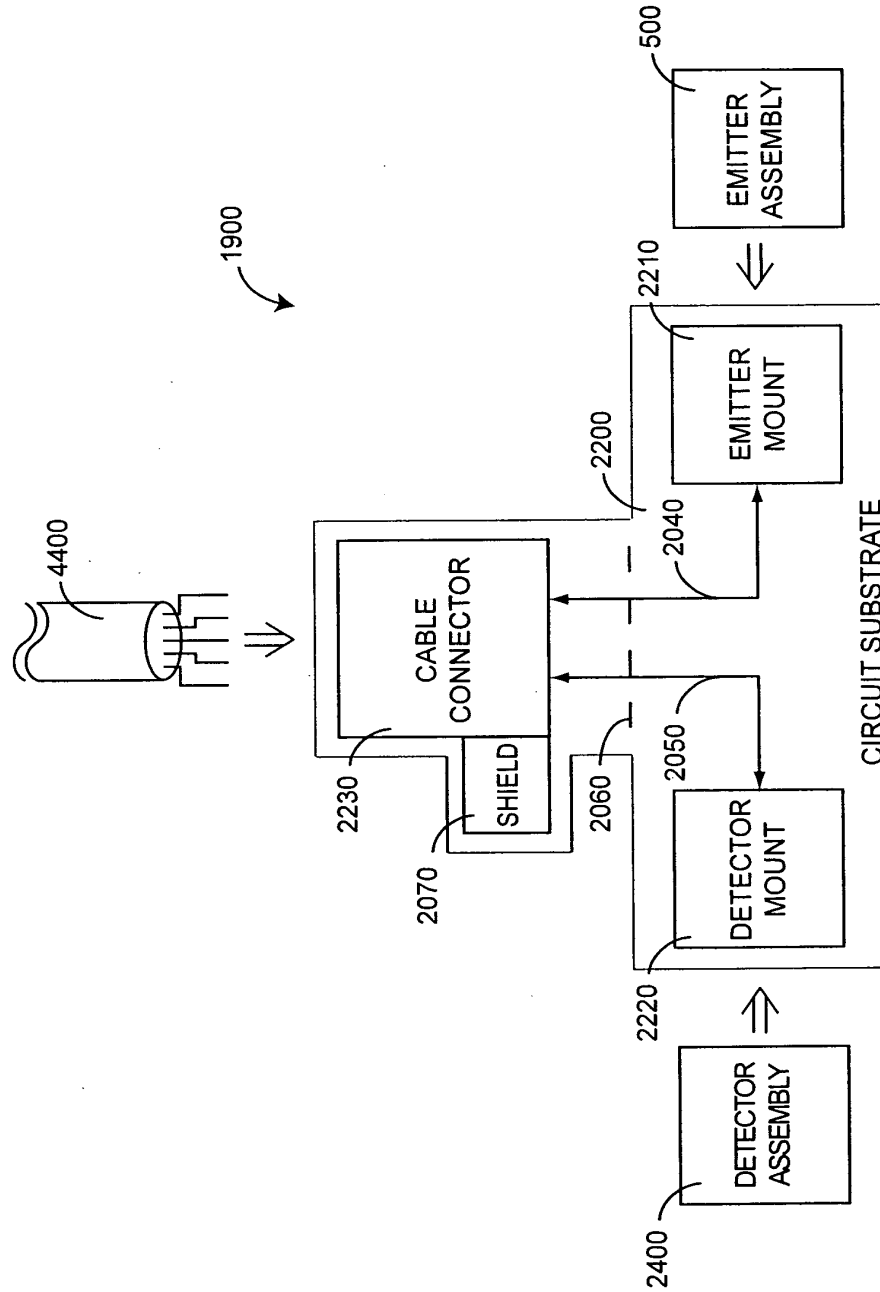

FIG. 20

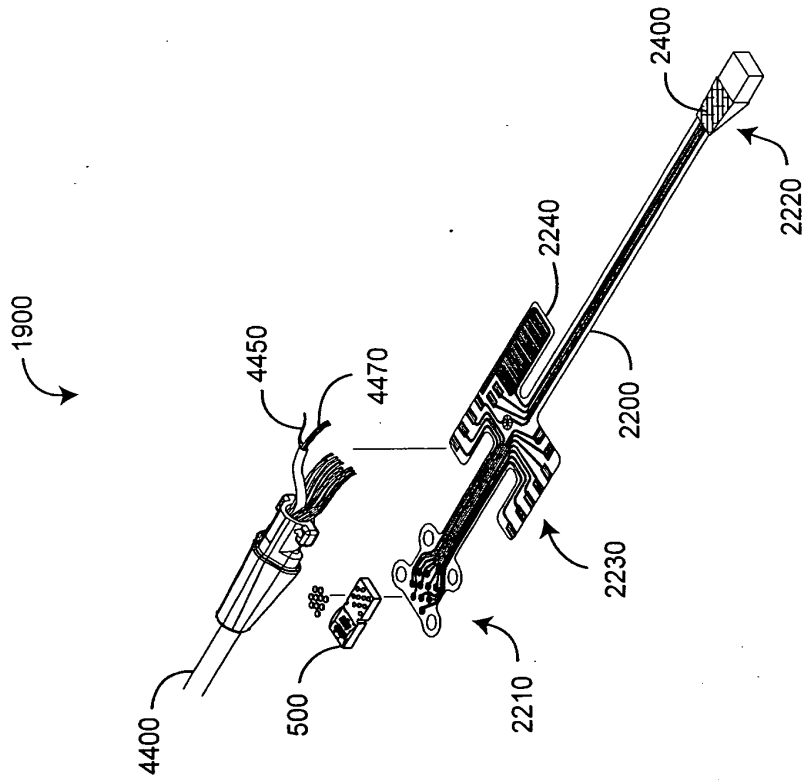

FIG. 21

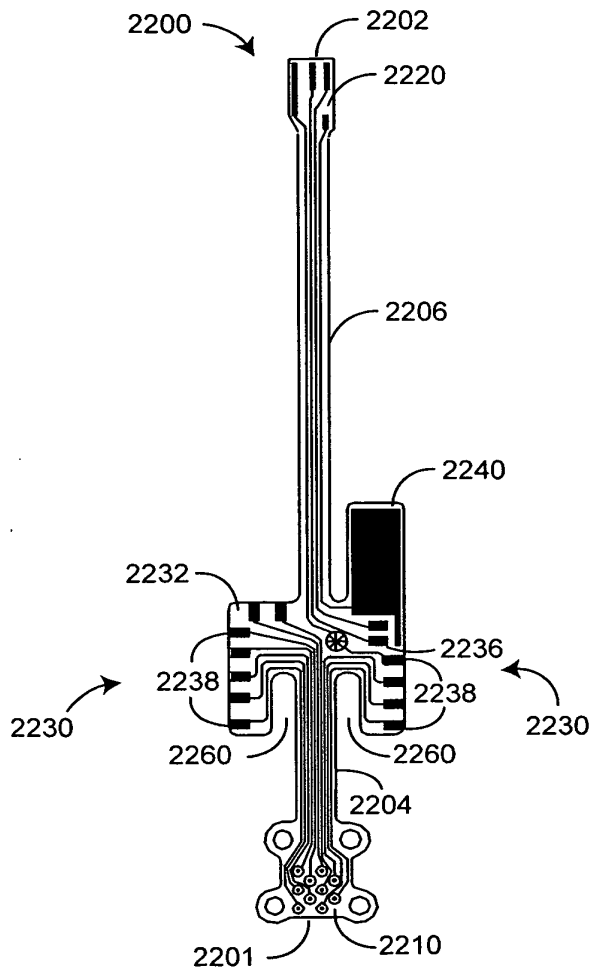

FIG. 22

MULTIPLE WAVELENGTH SENSOR SUBSTRATE

Ammar Al-Ali et al.

Appl. No.: Unknown Atty Docket: MLR.004A

22/48

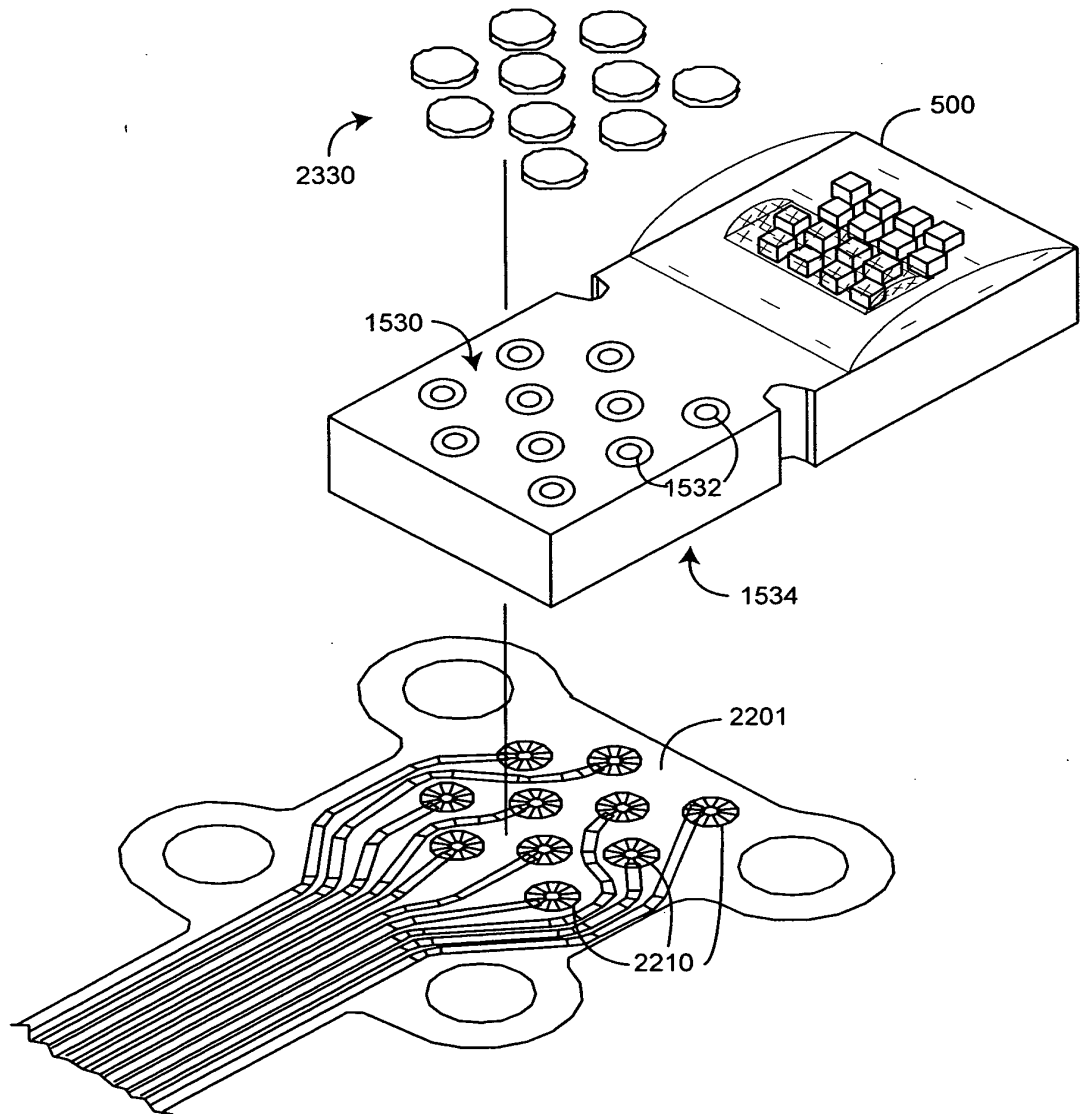

FIG. 23

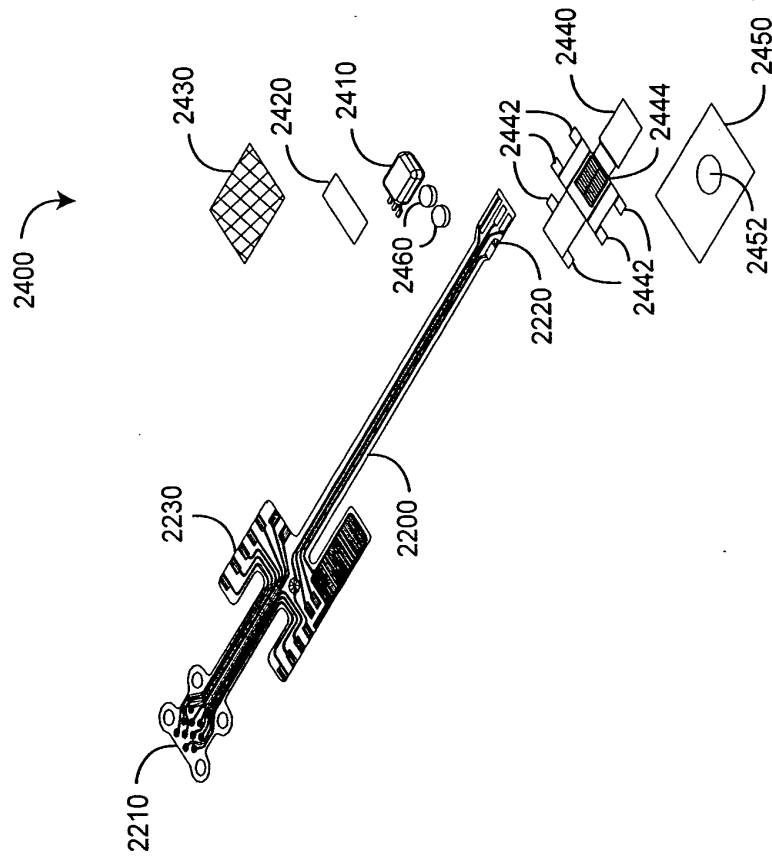

FIG. 24

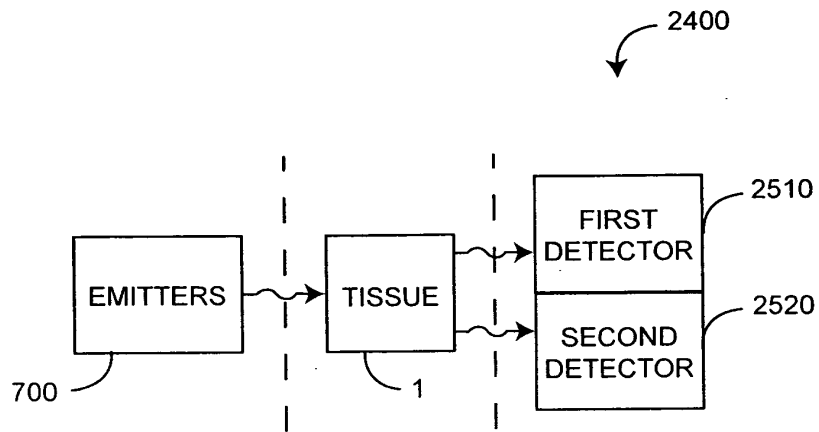

FIG. 25

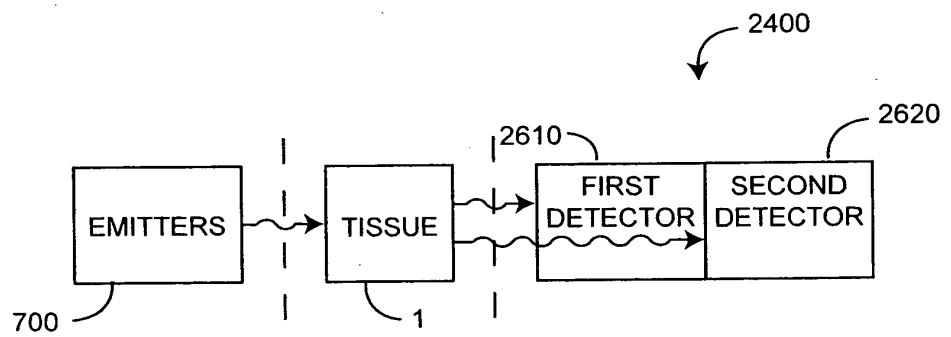

FIG. 26

MULTIPLE WAVELENGTH SENSOR SUBSTRATE

Ammar Al-Ali et al.

Appl. No.: Unknown Atty Docket: MLR.004A

25/48

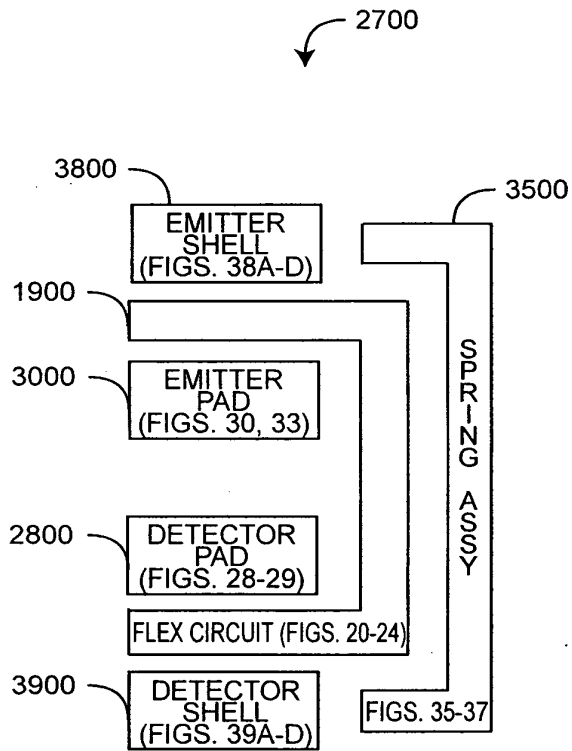

FIG. 27

2800

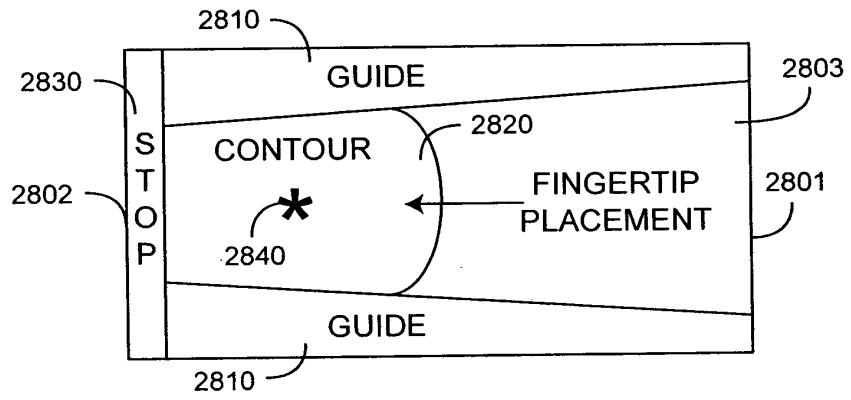

FIG. 28

27/48

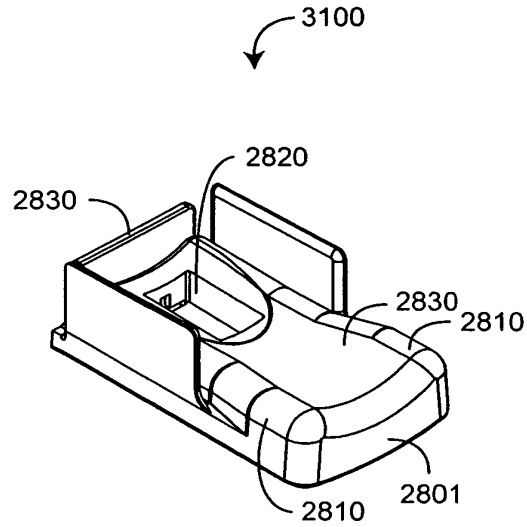

FIG. 29A

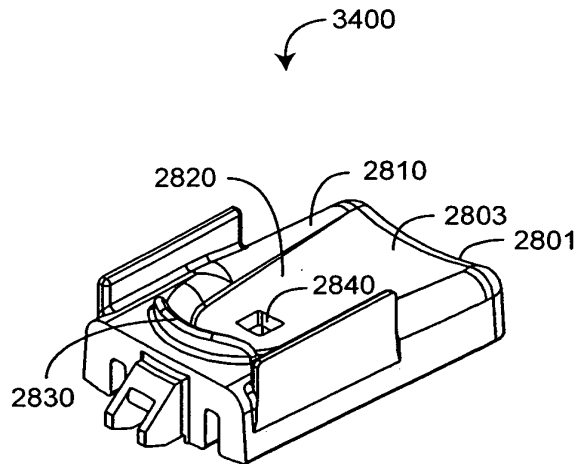

FIG. 29B

28/48

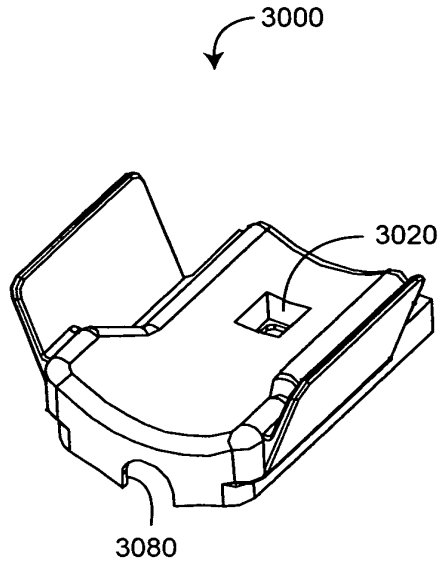

FIG. 30A

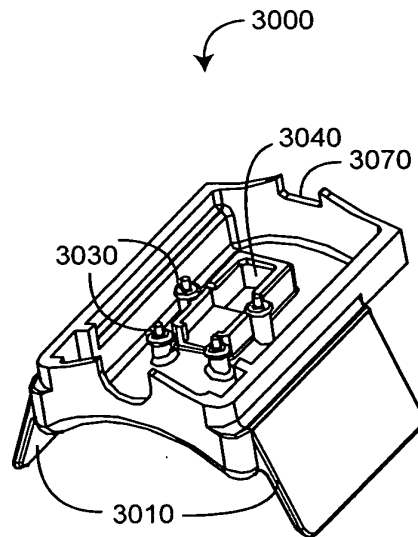

FIG. 30B

29/48

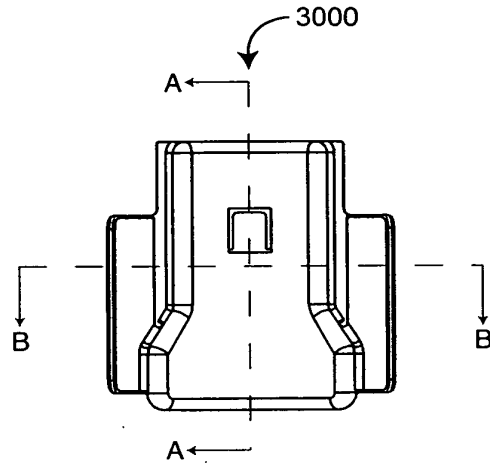
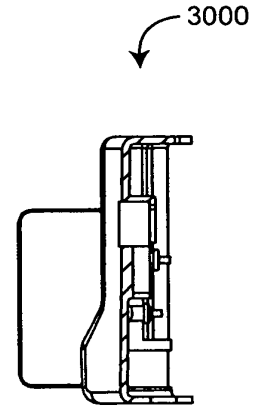

FIG. 30C



SECTION A-A

FIG. 30F

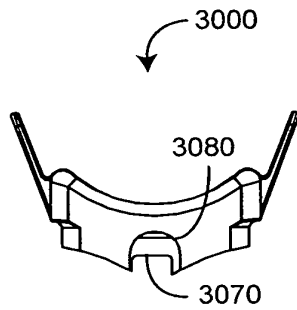

FIG. 30D

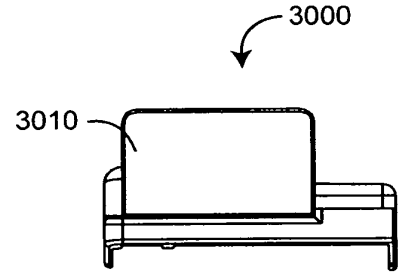

FIG. 30G

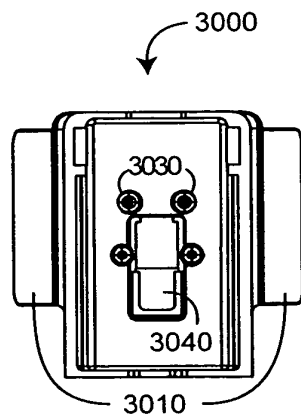
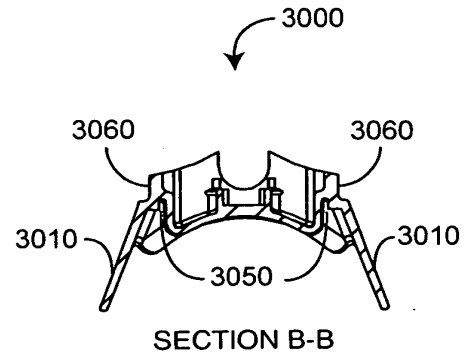

FIG. 30E



SECTION B-B

FIG. 30H

30/48

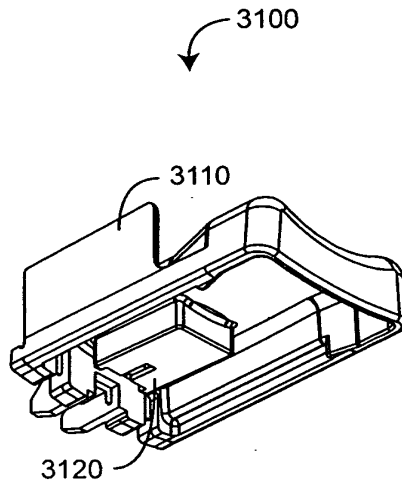

FIG. 31A

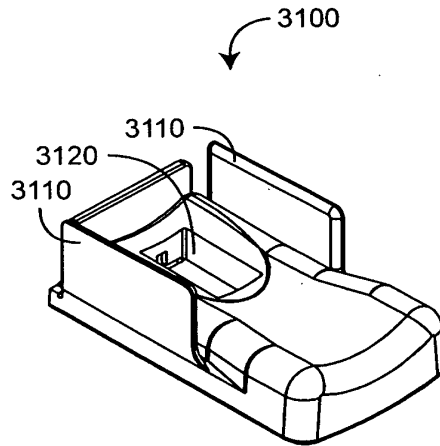
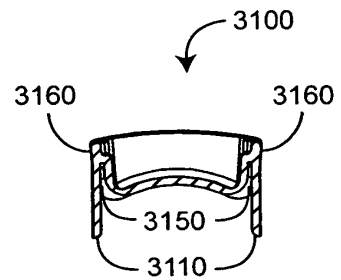
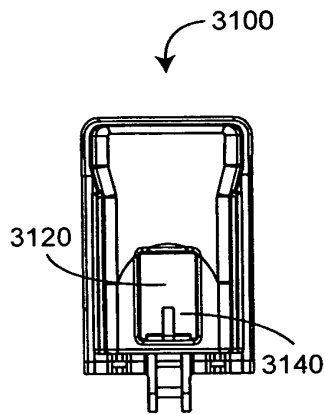
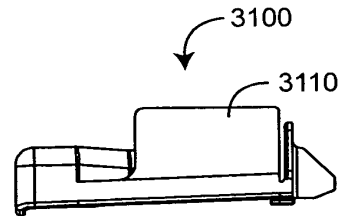
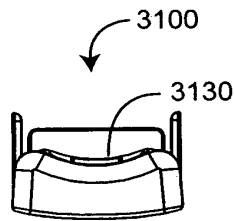
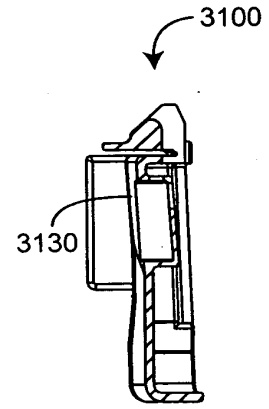
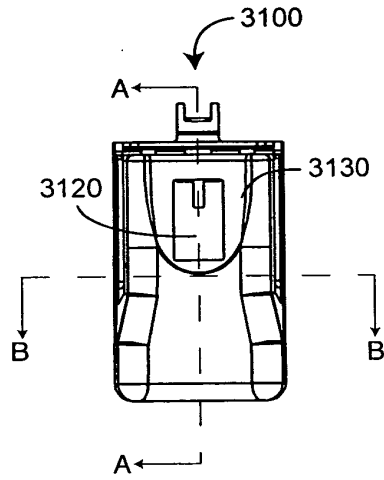

FIG. 31B



32/48

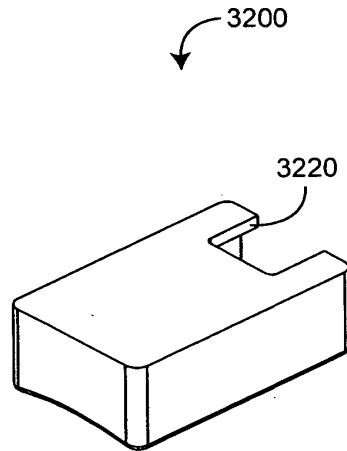

FIG. 32A

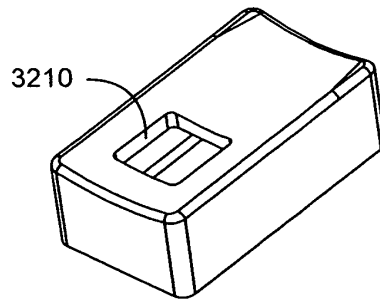

FIG. 32B

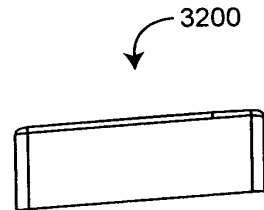
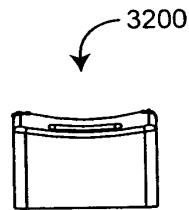
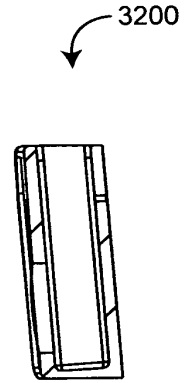
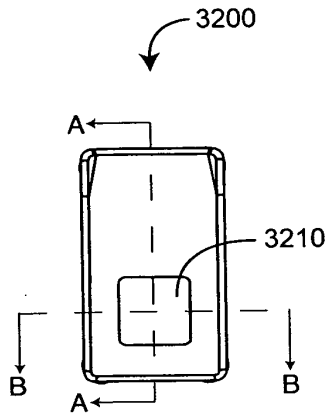
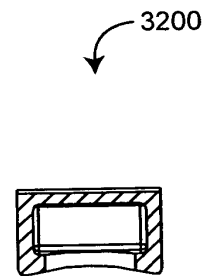
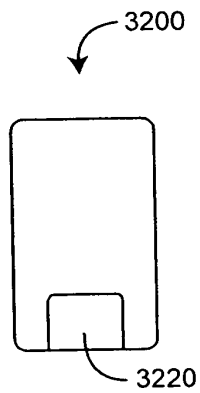

FIG. 32D

FIG. 32G



34/48

3300

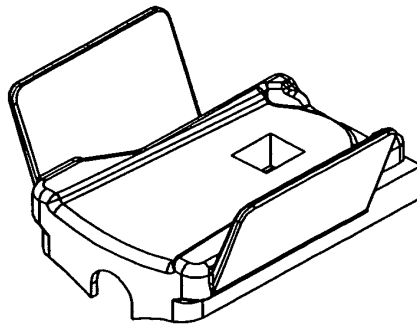

FIG. 33A

3300

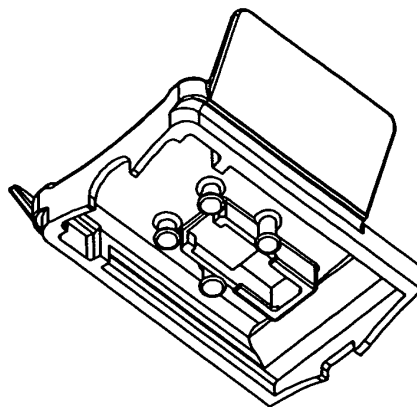

FIG. 33B

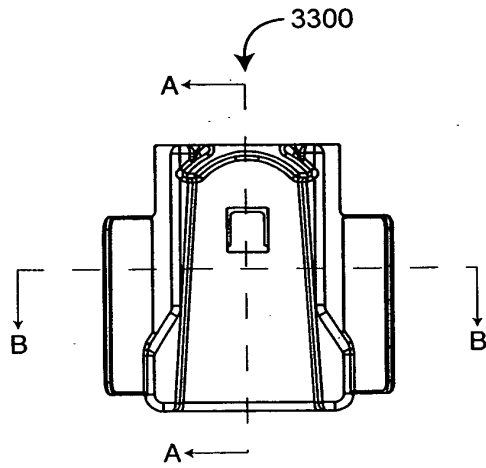

FIG. 33C

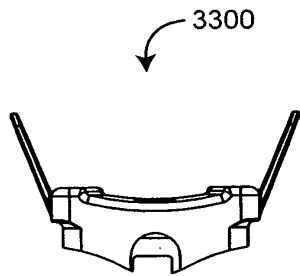

FIG. 33D

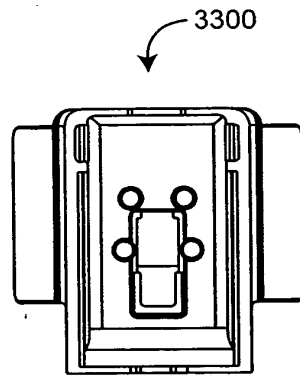

FIG. 33E

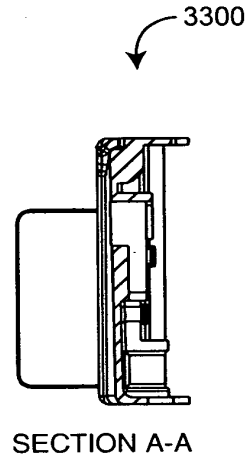

FIG. 33F

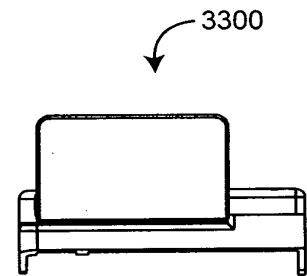

FIG. 33G

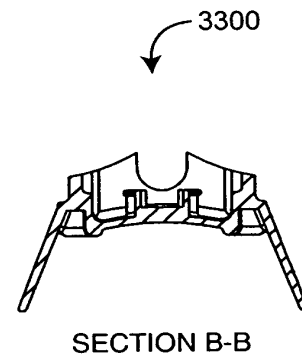

FIG. 33H

36/48

3400

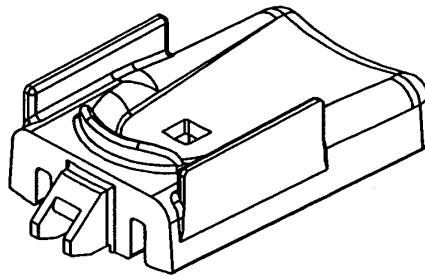

FIG. 34A

3400

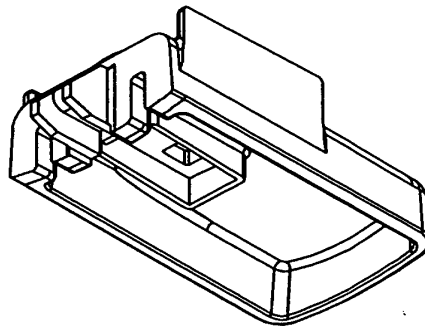

FIG. 34B

37/48

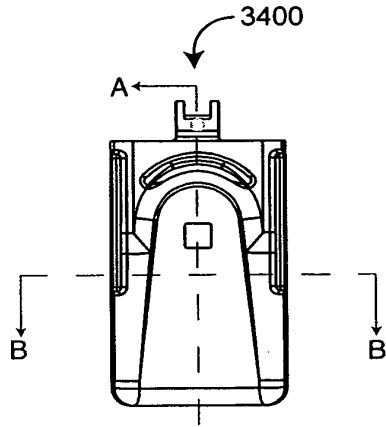

FIG. 34C

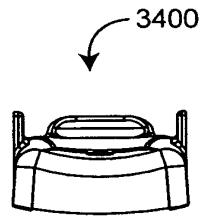

FIG. 34D

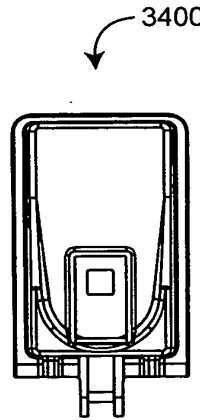
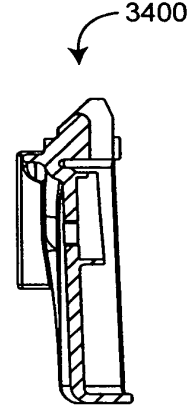

FIG. 34E



SECTION A-A

FIG. 34F

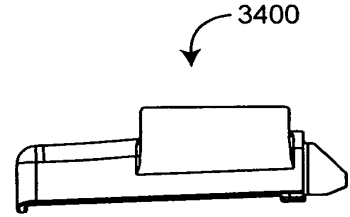
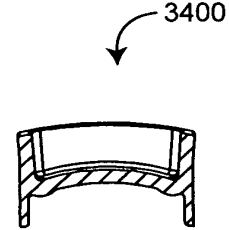

FIG. 34G



SECTION B-B

FIG. 34H

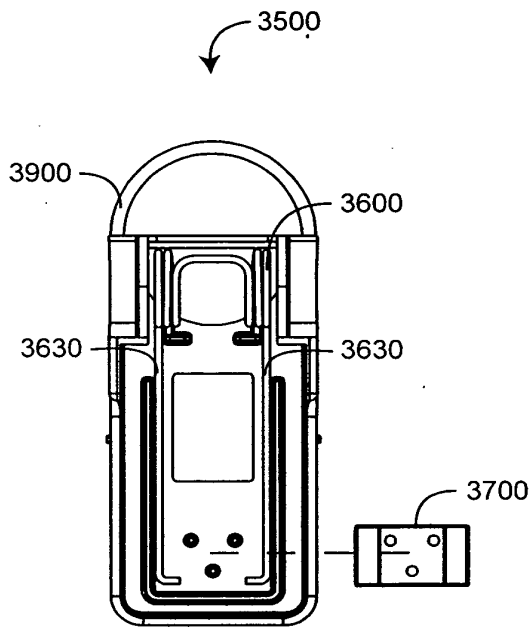

FIG. 35A

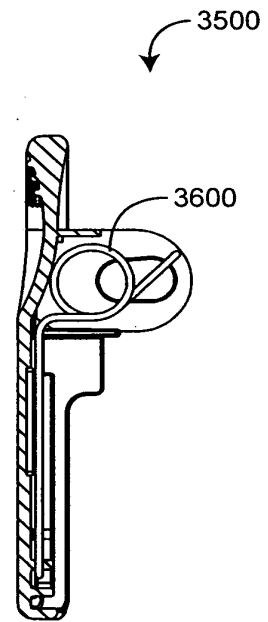

FIG. 35B

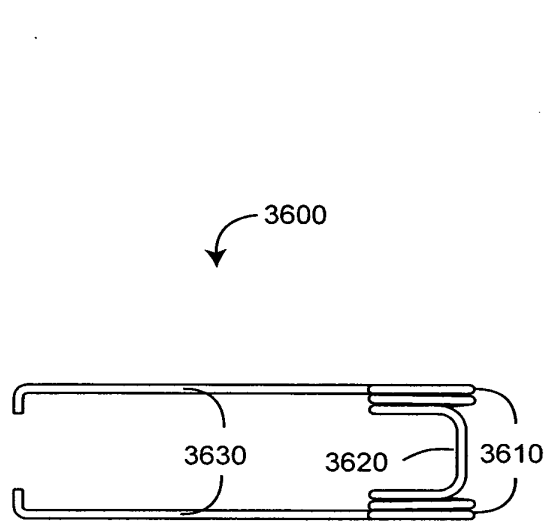

FIG. 36A

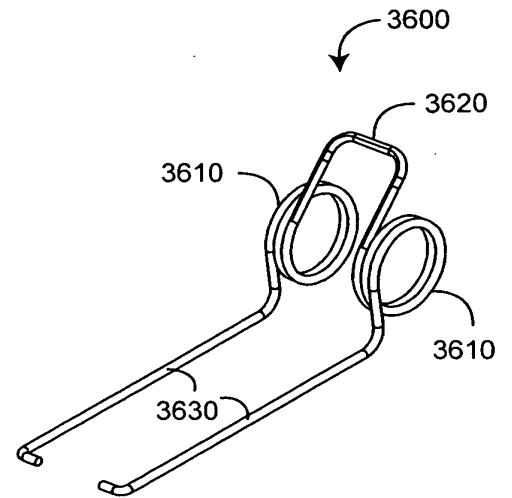

FIG. 36B

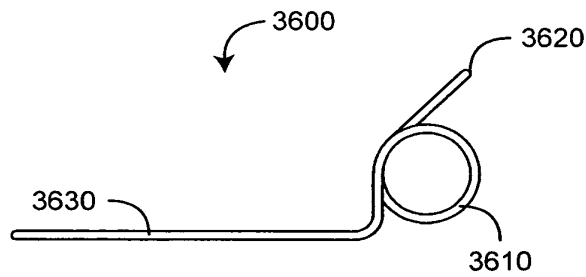

FIG. 36C

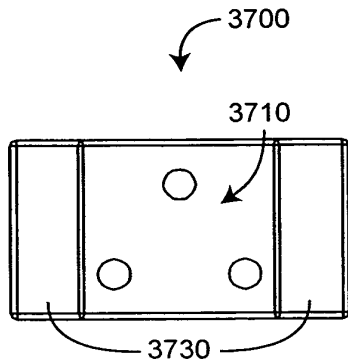

FIG. 37A

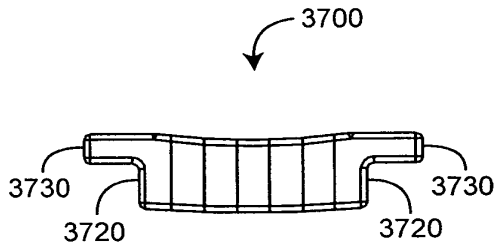

FIG. 37B

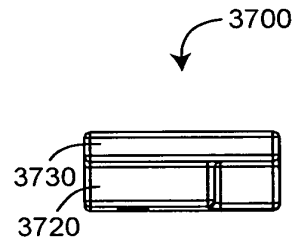

FIG. 37D

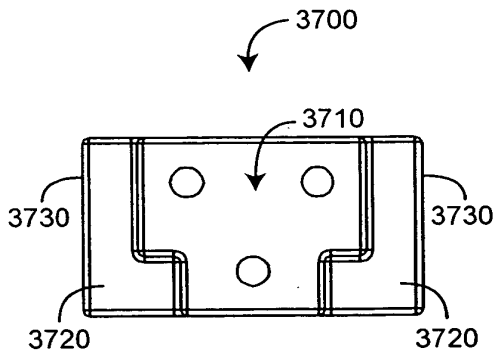
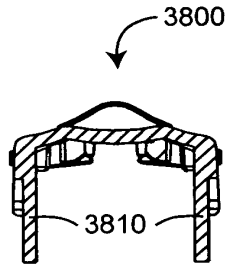

FIG. 37C



SECTION B-B
FIG. 38A

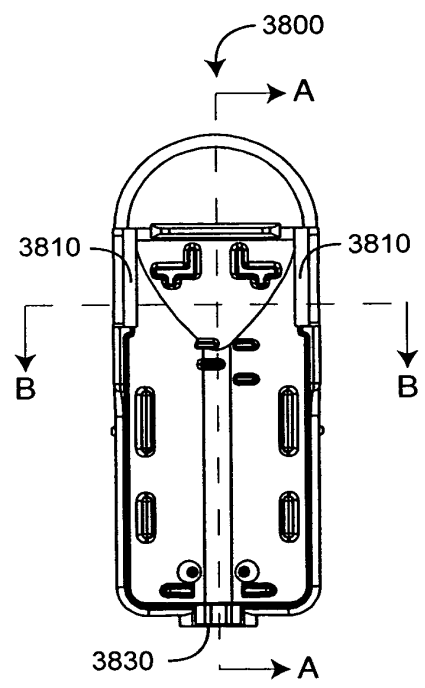
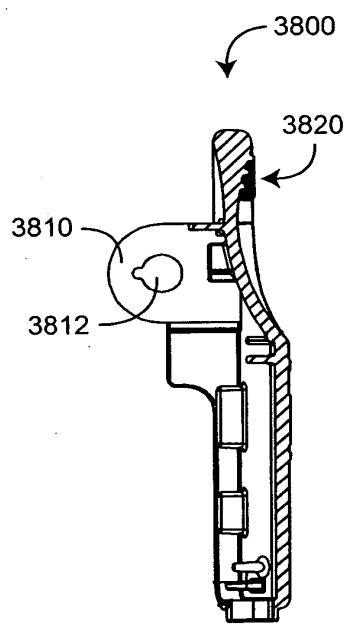

FIG. 38B



SECTION A-A
FIG. 38D

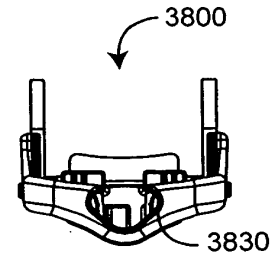

FIG. 38C

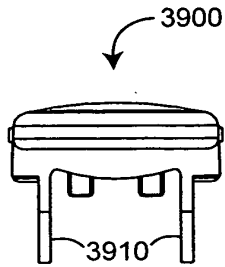

FIG. 39A

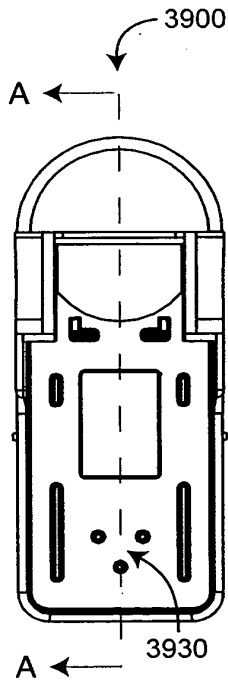
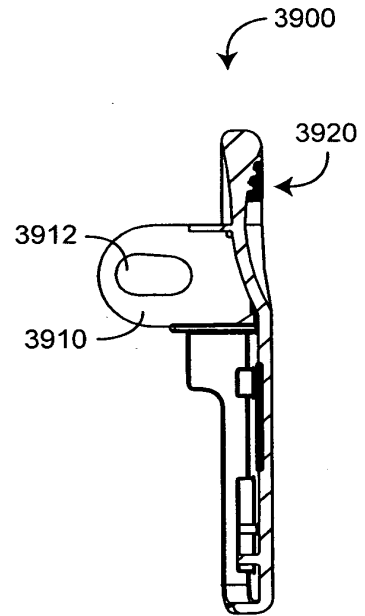

FIG. 39B



SECTION A-A
FIG. 39D

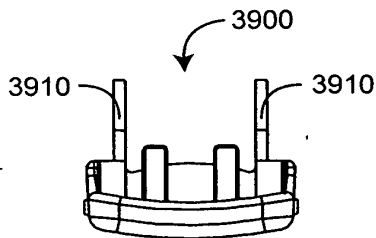

FIG. 39C

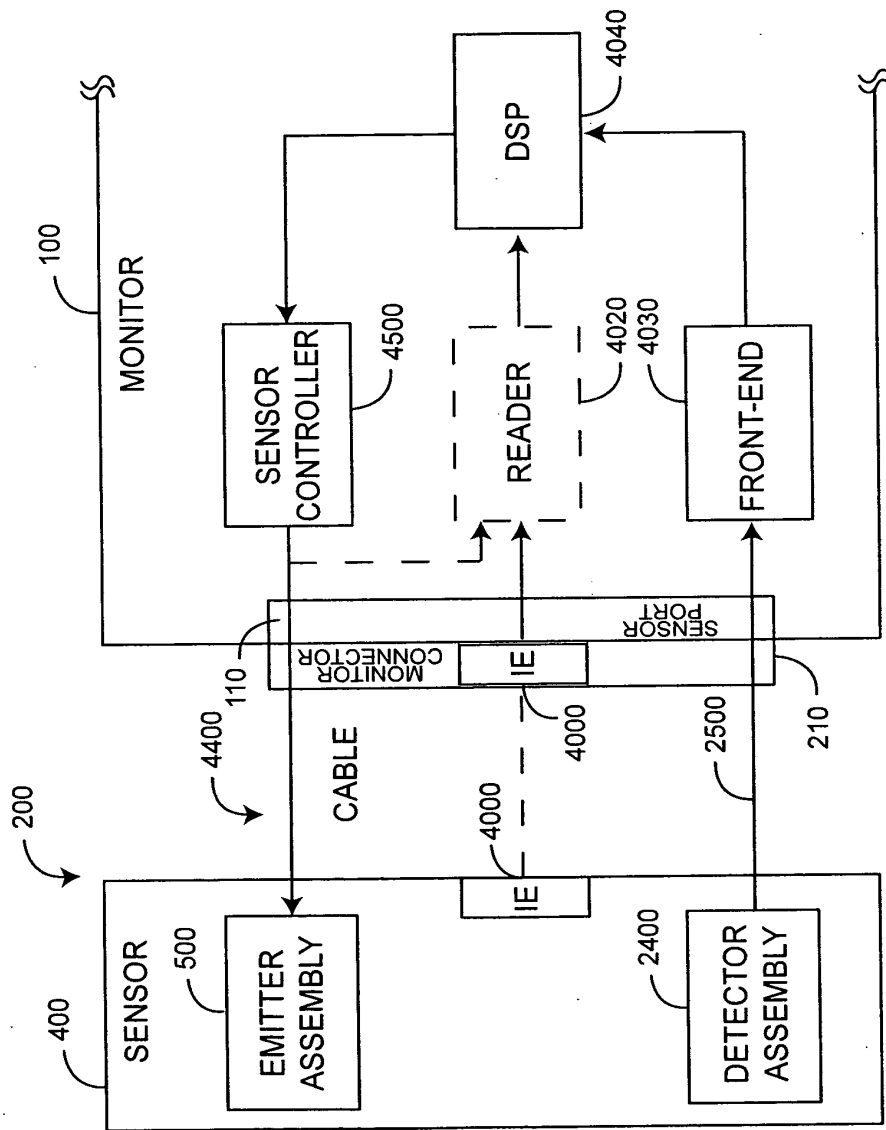

FIG. 40

44/48

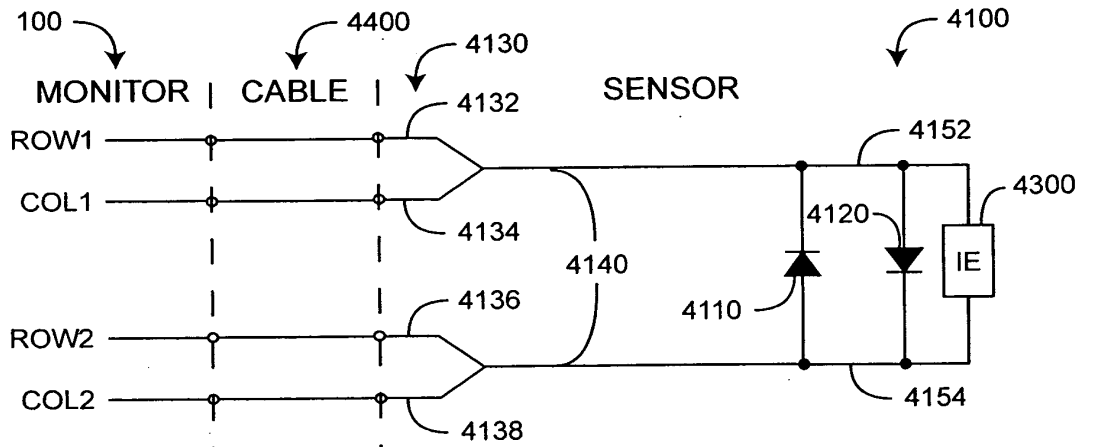

FIG. 41A

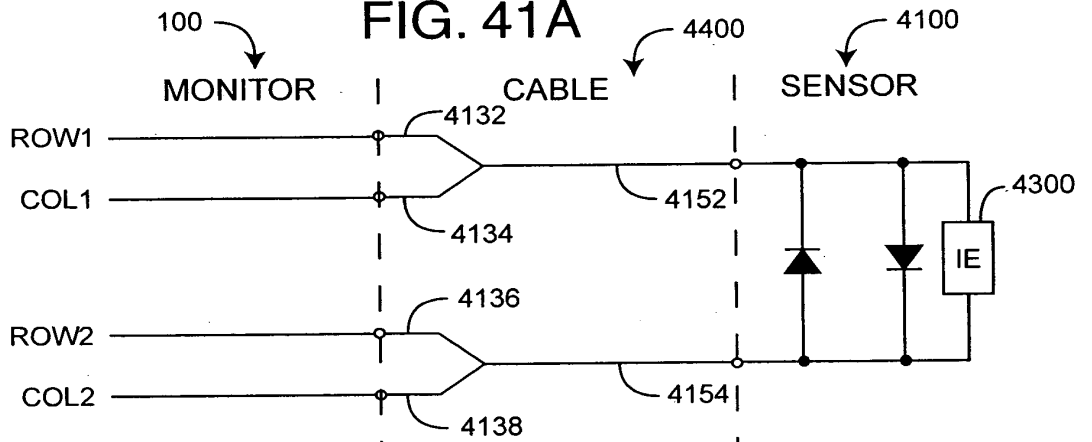

FIG. 41B

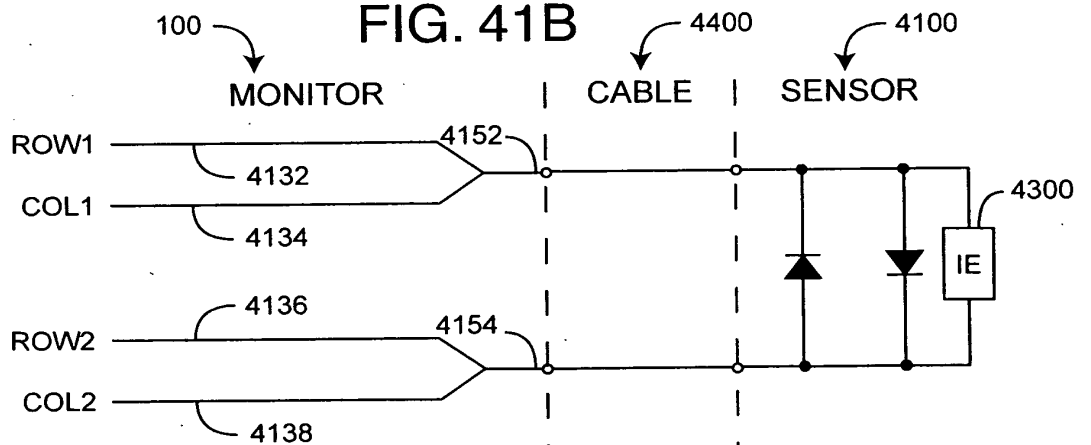

FIG. 41C

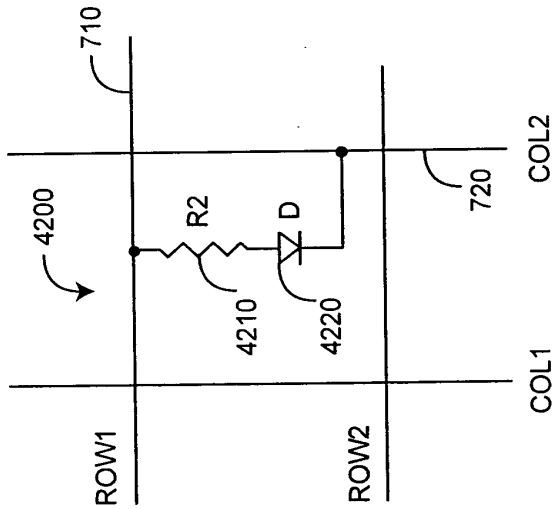

FIG. 42

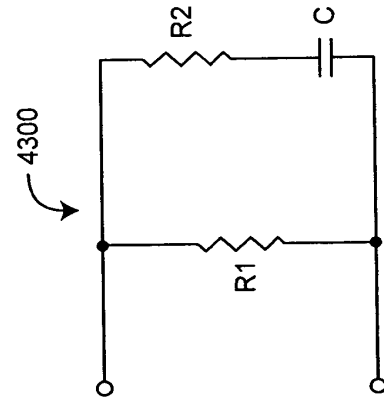

FIG. 43A

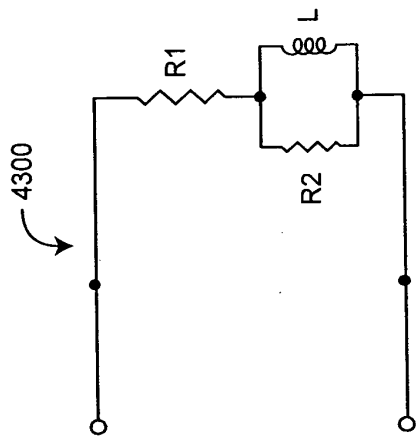

FIG. 43B

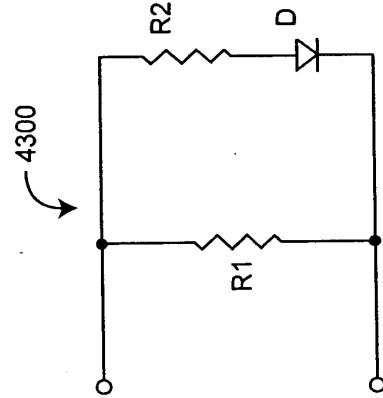

FIG. 43C

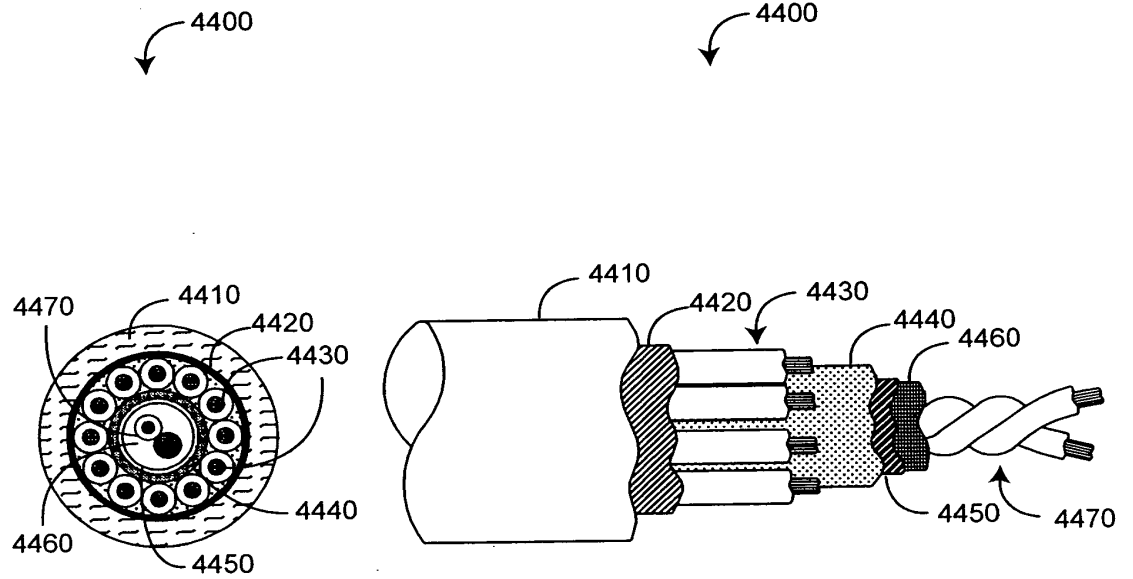

FIG. 44A

FIG. 44B

47/48

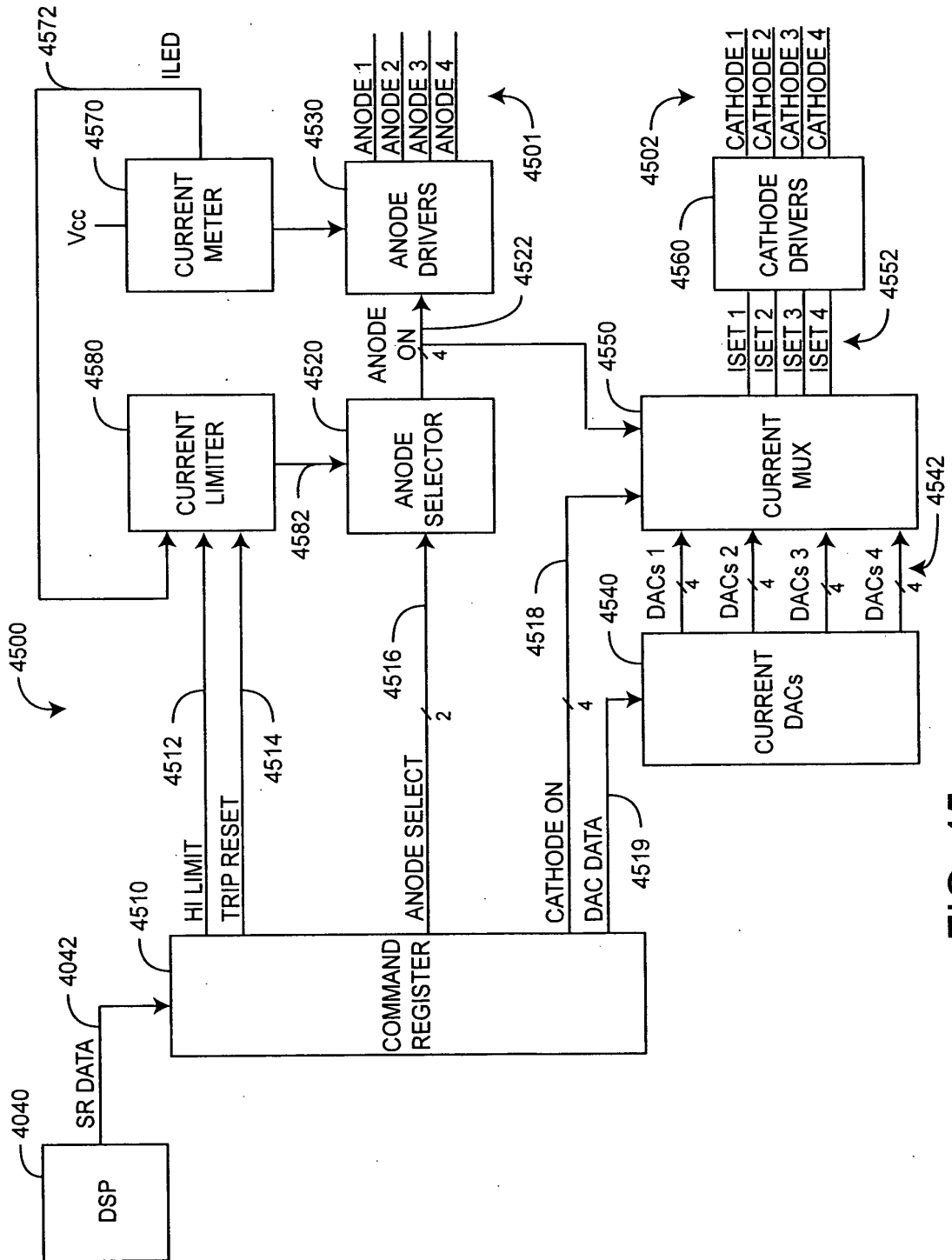

FIG. 45

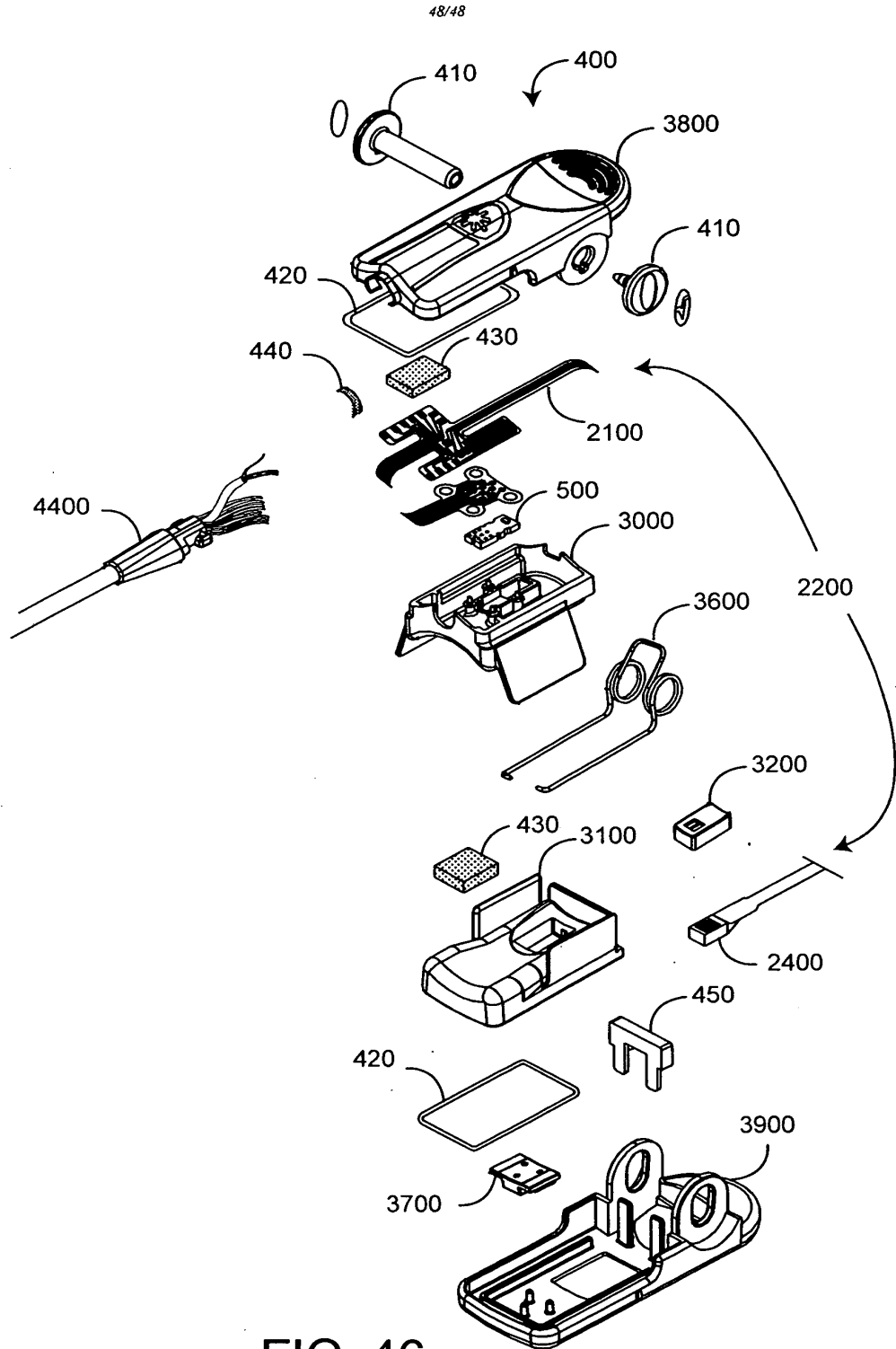

FIG. 46

**This Page is Inserted by IFW Indexing and Scanning
Operations and is not part of the Official Record**

BEST AVAILABLE IMAGES

Defective images within this document are accurate representations of the original documents submitted by the applicant.

Defects in the images include but are not limited to the items checked:

- BLACK BORDERS
- IMAGE CUT OFF AT TOP, BOTTOM OR SIDES
- FADED TEXT OR DRAWING
- BLURRED OR ILLEGIBLE TEXT OR DRAWING
- SKEWED/SLANTED IMAGES
- COLOR OR BLACK AND WHITE PHOTOGRAPHS
- GRAY SCALE DOCUMENTS
- LINES OR MARKS ON ORIGINAL DOCUMENT
- REFERENCE(S) OR EXHIBIT(S) SUBMITTED ARE POOR QUALITY
- OTHER: _____

IMAGES ARE BEST AVAILABLE COPY.

As rescanning these documents will not correct the image problems checked, please do not report these problems to the IFW Image Problem Mailbox.

Under the Paperwork Reduction Act of 1995, no persons are required to respond to a collection of information unless it displays a valid OMB control number.

PATENT APPLICATION FEE DETERMINATION RECORD Substitute for Form PTO-875				Application or Docket Number 11366209			
APPLICATION AS FILED – PART I							
(Column 1)		(Column 2)		SMALL ENTITY			
OR		OTHER THAN SMALL ENTITY					
FOR	NUMBER FILED	NUMBER EXTRA	RATE (\$)	FEE (\$)	RATE (\$)	FEE (\$)	
BASIC FEE (37 CFR 1.16(a), (b), or (c))						300	
SEARCH FEE (37 CFR 1.16(k), (l), or (m))						500	
EXAMINATION FEE (37 CFR 1.16(o), (p), or (q))						200	
TOTAL CLAIMS (37 CFR 1.16(i))	15	minus 20 = *	X\$ 25=		X\$50=		
INDEPENDENT CLAIMS (37 CFR 1.16(h))	4	minus 3 = *	X\$100=		X\$200=	200	
APPLICATION SIZE FEE (37 CFR 1.16(s))	If the specification and drawings exceed 100 sheets of paper, the application size fee due is \$250 (\$125 for small entity) for each additional 50 sheets or fraction thereof. See 35 U.S.C. 41(a)(1)(G) and 37 CFR						
MULTIPLE DEPENDENT CLAIM PRESENT (37 CFR 1.16(j))			N/A		N/A		
			TOTAL		TOTAL	1200	
* If the difference in column 1 is less than zero, enter "0" in column 2.							
APPLICATION AS AMENDED – PART II							
(Column 1)		(Column 2)		(Column 3)			
OR		OTHER THAN SMALL ENTITY					
AMENDMENT A	CLAIMS REMAINING AFTER AMENDMENT	HIGHEST NUMBER PREVIOUSLY PAID FOR	PRESENT EXTRA	RATE (\$)	ADDITIONAL FEE (\$)	RATE (\$)	ADDITIONAL FEE (\$)
	Total (37 CFR 1.16(i))	Minus	**	=	X =	X =	X =
	Independent (37 CFR 1.16(h))	Minus	***	=	X =	X =	X =
	Application Size Fee (37 CFR 1.16(s))			N/A		N/A	
	FIRST PRESENTATION OF MULTIPLE DEPENDENT CLAIM (37 CFR 1.16(j))			N/A		N/A	
			TOTAL ADD'T FEE		TOTAL ADD'T FEE		
(Column 1)		(Column 2)		(Column 3)			
OR		OTHER THAN SMALL ENTITY					
AMENDMENT B	CLAIMS REMAINING AFTER AMENDMENT	HIGHEST NUMBER PREVIOUSLY PAID FOR	PRESENT EXTRA	RATE (\$)	ADDITIONAL FEE (\$)	RATE (\$)	ADDITIONAL FEE (\$)
	Total (37 CFR 1.16(i))	Minus	**	=	X =	X =	X =
	Independent (37 CFR 1.16(h))	Minus	***	=	X =	X =	X =
	Application Size Fee (37 CFR 1.16(s))			N/A		N/A	
	FIRST PRESENTATION OF MULTIPLE DEPENDENT CLAIM (37 CFR 1.16(j))			N/A		N/A	
			TOTAL ADD'T FEE		TOTAL ADD'T FEE		
* If the entry in column 1 is less than the entry in column 2, write "0" in column 3.							
** If the "Highest Number Previously Paid For" IN THIS SPACE is less than 20, enter "20".							
*** If the "Highest Number Previously Paid For" IN THIS SPACE is less than 3, enter "3".							
The "Highest Number Previously Paid For" (Total or Independent) is the highest number found in the appropriate box in column 1.							

This collection of information is required by 37 CFR 1.16. The information is required to obtain or retain a benefit by the public which is to file (and by the USPTO to process) an application. Confidentiality is governed by 35 U.S.C. 122 and 37 CFR 1.14. This collection is estimated to take 12 minutes to complete, including gathering, preparing, and submitting the completed application form to the USPTO. Time will vary depending upon the individual case. Any comments on the amount of time you require to complete this form and/or suggestions for reducing this burden, should be sent to the Chief Information Officer, U.S. Patent and Trademark Office, U.S. Department of Commerce, P.O. Box 1450, Alexandria, VA 22313-1450. DO NOT SEND FEES OR COMPLETED FORMS TO THIS ADDRESS. **SEND TO: Commissioner for Patents, P.O. Box 1450, Alexandria, VA 22313-1450.**

If you need assistance in completing the form, call 1-800-PTO-9199 and select option 2.