

(19) [Issuing Country] Japan Patent Office (JP)  
(12) [Publication Name] Gazette of Unexamined Patent Applications (A)  
(11) [Publication Number] 2004-337605 (P2004-337605A)  
(43) [Publication Date] December 2, 2004 (2004.12.2)

---

(51) [Int.Cl.<sup>7</sup>] A61B 5/145  
          G01J 1/02  
          G01N 21/35  
[FI]      A61B 5/14 310  
          G01J 1/02 P  
          G01N 21/35 Z

[Theme Codes (Reference)] 2G059, 2G065, 4C038  
[Examination Request] Not Yet Received  
[Number of Claims] 35  
[Application Format] Online (OL)  
[Total Number of Pages] 23

---

(21) [Application Number] 2004-128918 (P2004-128918)  
(22) [Filing Date] April 23, 2004 (2004.4.23)  
(31) [Priority Number] 2003-118301 (P2003-118301)  
(32) [Priority Date] April 23, 2003 (2003.4.23)  
(33) [Priority Country] Japan (JP)  
(71) [Applicant]  
[Identification Number] 000103493  
[Name] OTAX Co., Ltd.  
[Address] 1215 Nippa-cho, Kohoku-ku, Yokohama-shi, Kanagawa-ken  
(71) [Applicant]  
[Identification Number] 503068875  
[Name] Yukio YAMADA  
[Address] 3-30-14-406 Takaidohigashi, Suginami-ku, Tokyo  
(71) [Applicant]  
[Identification Number] 803000045  
[Name] Campus Create Co., Ltd.  
[Address] 1-48-14 Okusawa, Setagaya-ku, Tokyo  
(74) [Agent]  
[Identification Number] 100091904  
[Attorney]  
[Name] Shigeo NARUSE  
(72) [Inventor]  
[Name] Yukio YAMADA  
[Address] 3-30-14-406 Takaidohigashi, Suginami-ku, Tokyo

Continued on Last Page

---

(54) [Title of the Invention]

Optical Probe, Measurement System Using the Same, and Reflected Light Detecting Method Using the Same

(57) [Abstract]

[Problem]

To provide an optical sensor that is easy to reduce in size. To provide an optical sensor that is less susceptible to heat generated by the light emitting unit.

[Solution]

A light emitting unit 11 emits light toward a reflecting unit 131 which has a diffuse reflective surface. The emitted light passes through an optical passage 14 before reaching the reflecting unit 131. The reflecting unit 131 then diffusely reflects the light from the light emitting unit 11 back toward the optical passage 14. The interior of the optical passage 14 is an integrating sphere due to the diffuse reflection of light by the reflecting unit 131. The optical passage 14 sends the light diffusely reflected by the reflecting unit 131 from the end portion 141 toward a fingernail 511. Some of the transmitted light is scattered and reflected inside a finger 51 and is received by a light receiving unit 12.

[Selected Drawing] Fig. 13

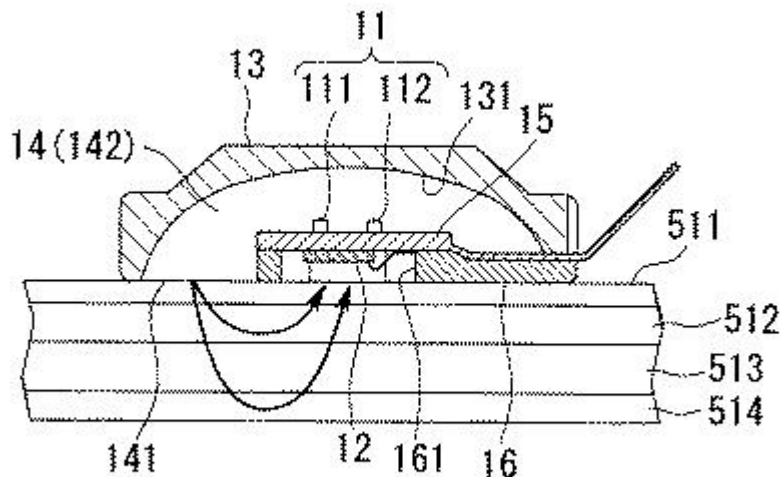

[Claims]

[Claim 1]

10 An optical probe comprising a light emitting unit, a light receiving unit, a reflecting unit, and an optical passage, the light receiving unit receiving light that has been emitted by the light emitting unit and that has passed through the optical passage and the outside, the reflecting unit reflecting light that has passed from the light emitting unit into the optical passage back into the optical passage, and the optical passage sends light emitted from the light emitting unit to the light receiving unit via the reflecting unit or the outside.

[Claim 2]

An optical probe according to claim 1, wherein the light emitting unit emits light toward the reflecting unit or the optical passage.

[Claim 3]

20 An optical probe according to claim 1, wherein the light emitting unit emits light toward the outside.

[Claim 4]

An optical probe according to any one of claims 1 to 3, wherein the light emitting unit emits light having at least two wavelengths.

[Claim 5]

30 An optical probe according to any one of claims 1 to 4, wherein the light emitting unit includes an LED or light emitting laser diode.

[Claim 6]

An optical probe according to any one of claims 1 to 4, wherein the light emitting unit includes a first light emitting unit and a second light emitting unit, the first light emitting unit includes an LED or a laser diode that emits light at a first wavelength, and the second light emitting unit includes an LED or a laser diode that emits light at a second wavelength.

[Claim 7]

40 An optical probe according to any one of claims 1 to 6, wherein the light receiving unit includes a photodiode that detects received light.

[Claim 8]

An optical probe according to any one of claims 1 to 7, wherein the reflecting unit has a diffuse reflective surface.

[Claim 9]

50 An optical probe according to any one of claims 1 to 8, wherein the reflecting unit is formed into a spherical shape.

[Claim 10]

An optical probe according to any one of claims 1 to 9, further comprising a main body, wherein the reflecting unit is formed on an inner surface of the main body, and the main body is deformable.

[Claim 11]

10 An optical probe according to any one of claims 1 to 10, wherein the optical passage comprises an end portion arranged around the light emitting unit or the light receiving unit.

[Claim 12]

An optical probe according to any one of claims 1 to 11, wherein the interior of the optical passage is filled with a transparent material.

[Claim 13]

20 An optical probe according to claim 12, wherein some or all of the transparent material is an epoxy resin.

[Claim 14]

An optical probe according to claim 12, wherein some or all of the transparent material is a silicone resin.

[Claim 15]

30 An optical probe according to any one of claims 1 to 14, wherein the light receiving unit or the light emitting unit is arranged on a board, and the board is deformable.

[Claim 16]

An optical probe according to any one of claims 1 to 15, wherein the light emitting unit is arranged on a board, and the board has heat transferring properties that guide heat generated by the light emitting unit toward the outside.

[Claim 17]

40 An optical probe according to any one of claims 1 to 4, wherein the light emitting unit includes a light guide.

[Claim 18]

An optical probe according to any one of claims 1 to 17, wherein the light receiving unit includes a light guide.

[Claim 19]

50 An optical probe comprising a light emitting unit, a light receiving unit, a reflecting unit, and an optical passage, the light emitting unit emits light toward the reflecting unit, the reflecting unit faces the light emitting unit and returns light that has been emitted from the light emitting unit to the optical passage, the optical passage is arranged between the light

emitting unit and the reflecting unit and the optical passage sends light emitted from the light emitting unit and reflected by the reflecting unit to the outside, and the light receiving unit receives light that has been emitted by the light emitting unit and that has passed through the optical passage and the outside.

[Claim 20]

10 An optical probe comprising a light emitting unit, a light receiving unit, a reflecting unit, and an optical passage, the light emitting unit emits light toward the outside, the optical passage takes in light that has been emitted by the light emitting unit and that has passed through the outside, and guides the light to the reflecting unit, the reflecting unit reflects the light that has been taken into the optical passage and sends the light to the light receiving unit via the optical passage, and the light receiving unit receives the light that has been sent by the optical passage.

[Claim 21]

20 An optical probe according to claim 19 or 20, wherein the light emitting unit is arranged on one surface of the board, and the light receiving unit is arranged on the other surface of the board.

[Claim 22]

A measurement system comprising: an optical probe according to any one of claims 1 to 21; and an analysis unit that analyzes the characteristics of the light received by the optical probe.

[Claim 23]

30 A reflected light detecting method comprising:  
(1) a step of emitting light that has been emitted from the light emitting unit from the periphery of the light receiving unit to the outside; and  
(2) a step of receiving some of the light that has been emitted to the outside and that has passed through the outside with the light receiving unit.

[Claim 24]

40 A detecting method according to claim 23, wherein the light emitted from the light emitting unit is diffusely reflected and then emitted in step (1).

[Claim 25]

50 A reflected light detecting method comprising:  
(1) a step of emitting light from the light emitting unit to the outside;  
(2) a step of taking some of the light that has been emitted toward the outside and that has passed through the outside into the optical passage from the periphery of the light emitting unit; and  
(3) a step of receiving the light that has been taken into the optical passage with the light receiving unit.

[Claim 26]

# Explore Litigation Insights

Docket Alarm provides insights to develop a more informed litigation strategy and the peace of mind of knowing you're on top of things.

## Real-Time Litigation Alerts



Keep your litigation team up-to-date with **real-time alerts** and advanced team management tools built for the enterprise, all while greatly reducing PACER spend.

Our comprehensive service means we can handle Federal, State, and Administrative courts across the country.

## Advanced Docket Research



With over 230 million records, Docket Alarm's cloud-native docket research platform finds what other services can't. Coverage includes Federal, State, plus PTAB, TTAB, ITC and NLRB decisions, all in one place.

Identify arguments that have been successful in the past with full text, pinpoint searching. Link to case law cited within any court document via Fastcase.

## Analytics At Your Fingertips



Learn what happened the last time a particular judge, opposing counsel or company faced cases similar to yours.

Advanced out-of-the-box PTAB and TTAB analytics are always at your fingertips.

## API

Docket Alarm offers a powerful API (application programming interface) to developers that want to integrate case filings into their apps.

## LAW FIRMS

Build custom dashboards for your attorneys and clients with live data direct from the court.

Automate many repetitive legal tasks like conflict checks, document management, and marketing.

## FINANCIAL INSTITUTIONS

Litigation and bankruptcy checks for companies and debtors.

## E-DISCOVERY AND LEGAL VENDORS

Sync your system to PACER to automate legal marketing.