



US005334916A

# United States Patent [19]

[11] Patent Number: 5,334,916

Noguchi

[45] Date of Patent: Aug. 2, 1994

[54] APPARATUS AND METHOD FOR LED EMISSION SPECTRUM CONTROL

[75] Inventor: Masahiro Noguchi, Ibaraki, Japan

[73] Assignee: Mitsubishi Kasei Corporation, Tokyo, Japan

[21] Appl. No.: 888,758

[22] Filed: May 27, 1992

[30] Foreign Application Priority Data

May 27, 1991 [JP] Japan ..... 3-121317

[51] Int. Cl.<sup>5</sup> ..... G05F 1/00; H05B 41/36

[52] U.S. Cl. .... 315/309

[58] Field of Search ..... 315/291, 309

[56] References Cited

U.S. PATENT DOCUMENTS

4,529,949 7/1985 deWit et al. .... 330/289

Primary Examiner—Tony M. Argenbright  
Attorney, Agent, or Firm—Armstrong, Westerman,  
Hattori, McLeland & Naughton

### [57] ABSTRACT

An emission spectrum controlling apparatus and method for an LED are disclosed. A temperature measurement device is provided for measuring the temperature of a light emitting diode or the temperature in the surrounding environment of the light emitting diode. A driving power control device is also provided for controlling the driving power of the LED, and a computing unit is disclosed which controls the driving power control device based on the temperature information from the temperature measuring device and the driving power information from the driving power control device.

8 Claims, 3 Drawing Sheets

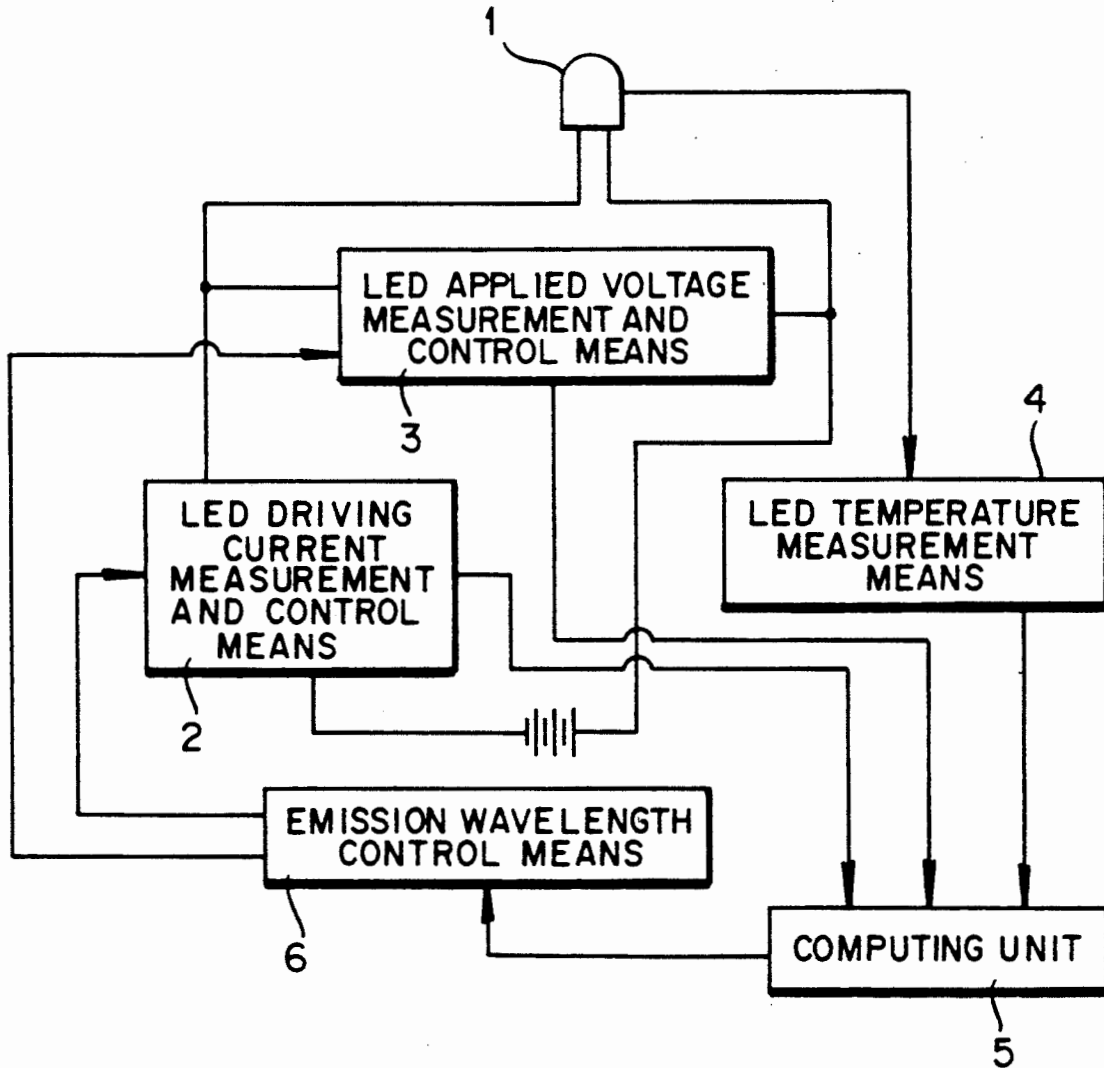

Fig. 1

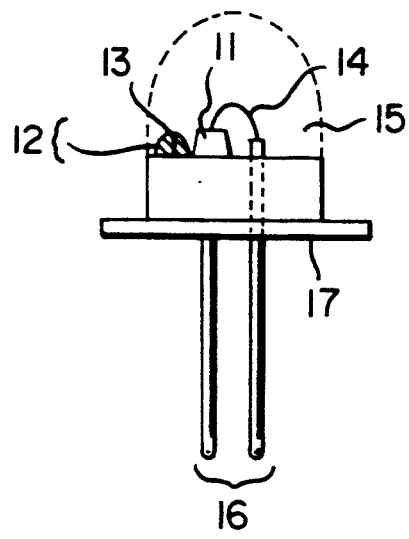
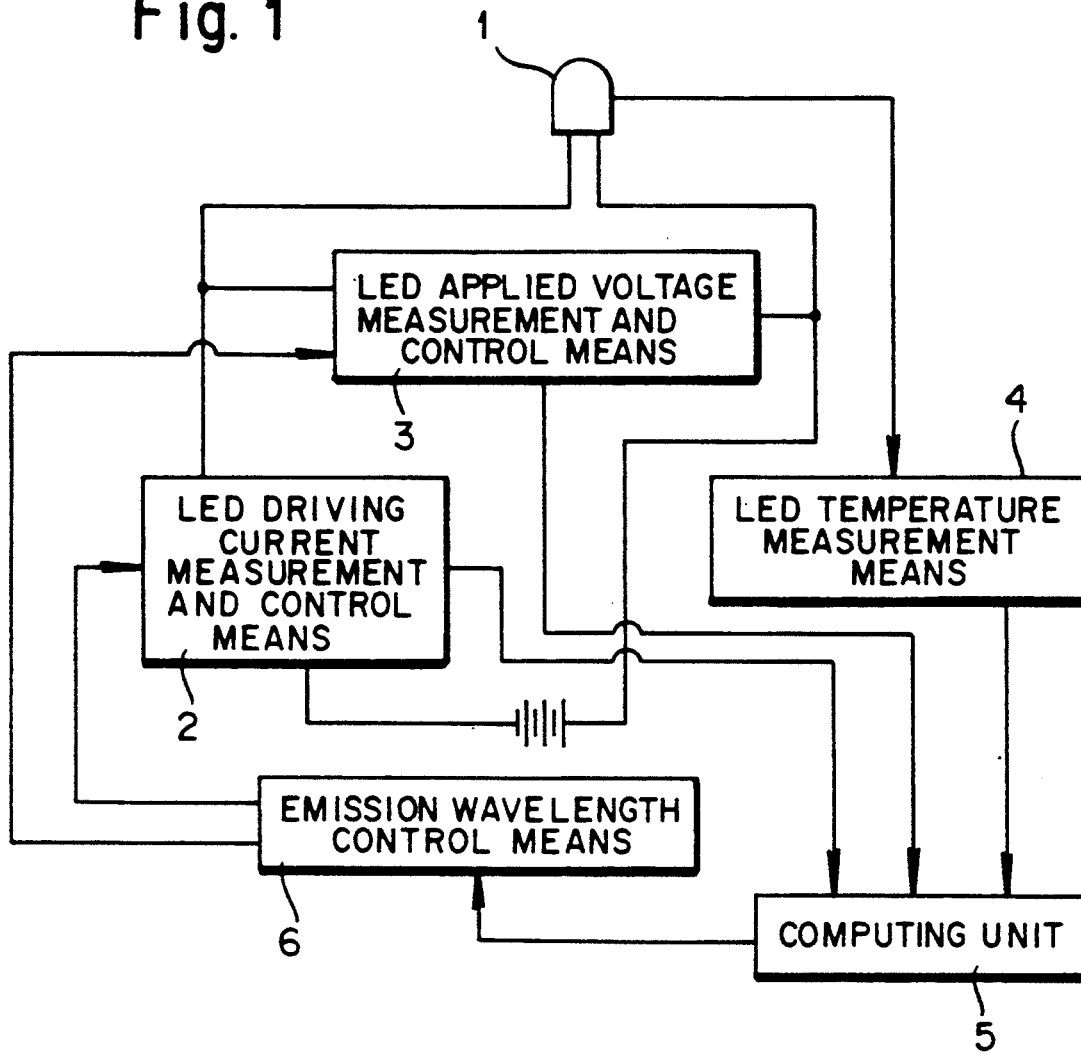
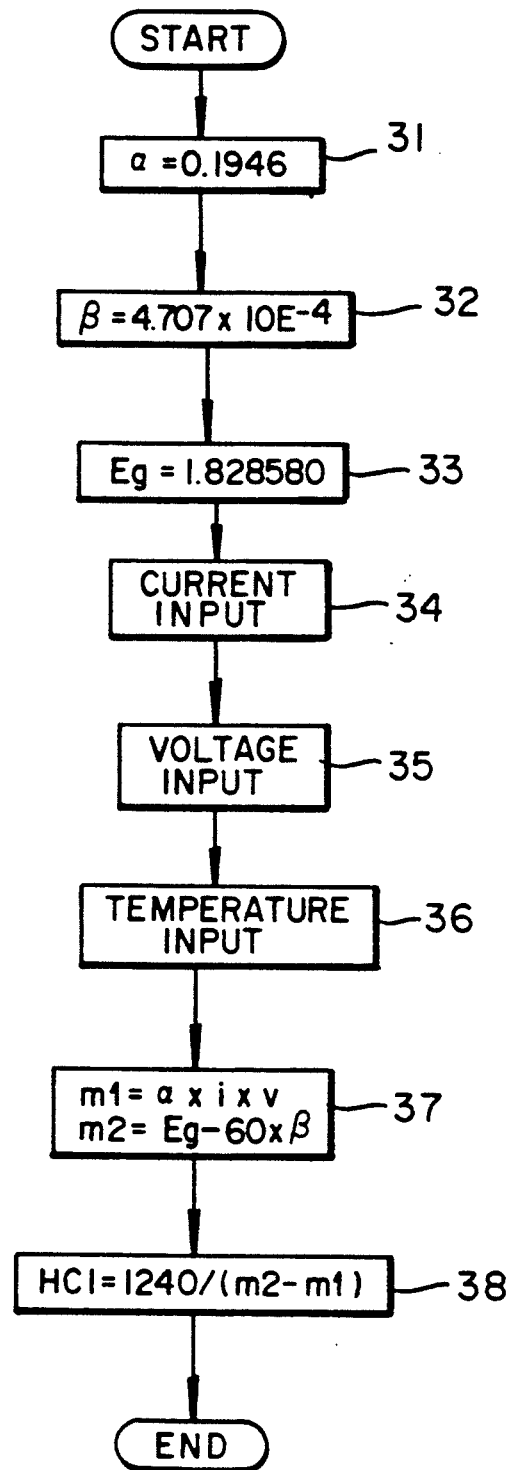

Fig. 2

Fig. 3



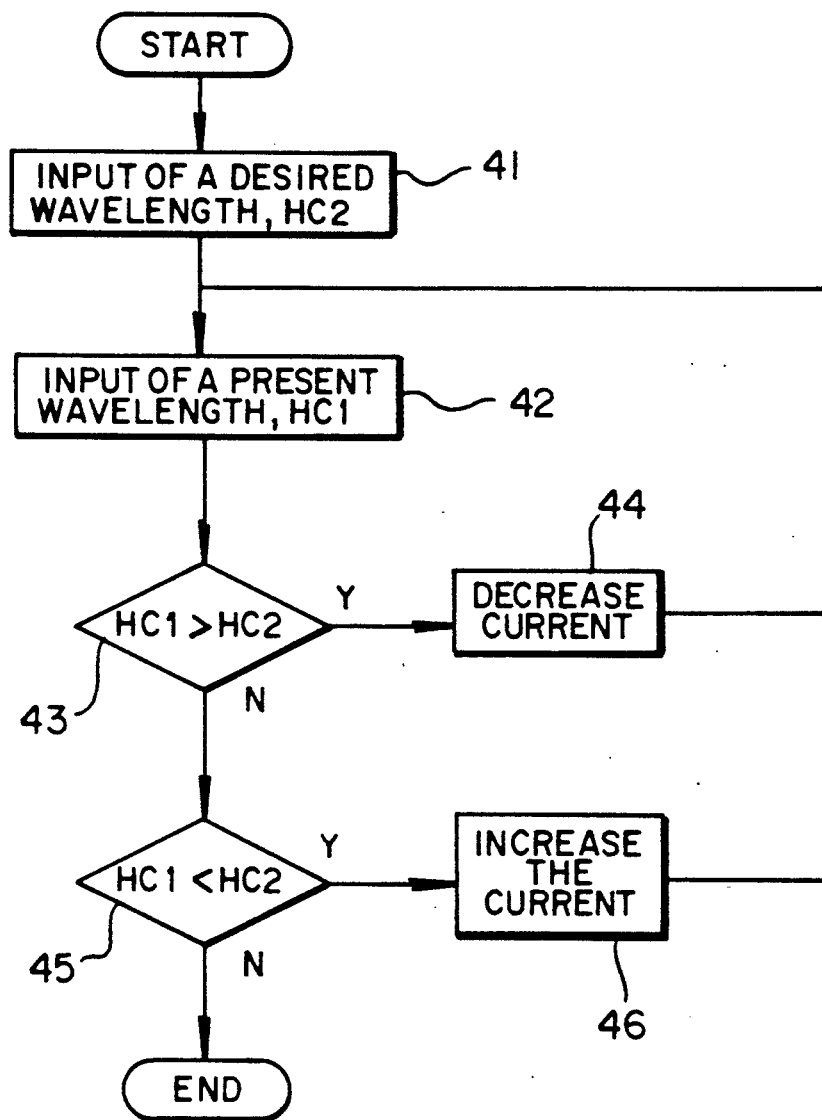

Fig. 4

## APPARATUS AND METHOD FOR LED EMISSION SPECTRUM CONTROL

### BACKGROUND OF THE INVENTION

#### 1. Field of the Invention

The present invention relates to an apparatus and method for controlling the emission spectrum of an LED with high precision, and can be utilized in connection with an emission element (LED) standard light source, an LED light source for a sensor, optical communication equipment, etc.

#### 2. Description of the Related Art

It is known in theory that an emission spectrum of an LED changes along with ambient temperature or a driving current. When an LED standard light source is manufactured which emits light of a particular spectrum, for example, based on the knowledge in theory of changes of emission spectrum of an LED, the LED is set in a thermostatic chamber and the temperature of the LED is kept at a specified value in monitoring the emission spectrum.

### SUMMARY OF THE INVENTION

An emission spectrum could be quantitatively and precisely monitored by using a spectrometer type measuring system for monitoring the emission spectrum, the system incorporating large and expensive devices such that the system as a whole is expensive and difficult to handle.

One object of the present invention is to improve the above-noted problems of expense and size.

Another object of the present invention is to provide an emission spectrum control apparatus and method which is small sized, easy to handle, has a simplified form, and which also has a low manufacturing cost by, for example, developing integrated circuitry.

In accordance with the above-noted objects, an emission spectrum control apparatus and method is provided comprising a temperature measurement means for measuring the temperature of an LED or for measuring the temperature in the environment in which the LED is disposed, a driving power control means for controlling the driving power of the LED, and a computing unit which controls the driving power control means based on temperature information from the temperature measurement means and driving power information from the driving power control means. A plurality of LEDs and a plurality of temperature measurement means can be utilized in the present invention.

### BRIEF DESCRIPTION OF THE DRAWINGS

The present invention will be further explained in connection with the accompanying drawings wherein:

FIG. 1 is a block diagram showing the system for LED emission spectrum control;

FIG. 2 illustrates an embodiment of the present invention having an LED with a thermocouple;

FIG. 3 is a flow chart for illustrating the system for calculating an emission wavelength; and

FIG. 4 is a flow chart illustrating the process for controlling the emission wavelength.

### DESCRIPTION OF THE PREFERRED EMBODIMENTS

In the present invention, an emission wavelength varies according to an optical band gap at a standard temperature, driving power and difference between the

temperature of an LED or the surrounding ambient temperature and the standard temperature. The temperature of the LED itself or the surrounding ambient temperature and the driving power of the LED are detected. Then, the emission wavelength energy can be calculated by subtracting the value of an applied power multiple by a specified coefficient and the difference from the standard temperature multiple by a specified coefficient from the optical band gap at the standard temperature. The emission wavelength can be controlled by controlling the driving power of the LED based on the output of the computing unit.

In FIG. 1, 1 is an LED with a sensor for measuring temperature, 2 is a measurement and control means for an LED driving current, 3 is a measurement and control means for an LED applied voltage, 4 is a measurement means for an LED temperature, 5 is a computing unit, and 6 is a control means for an emission wavelength.

The temperature of the LED is measured by a temperature sensor. However, the temperature to be measured is not limited to the temperature of the LED itself, but the temperature in the environment surrounding the LED can also be measured. The sensor to be used can be either a contact-type or a non contact-type sensor. The desirable range in which the sensor is to be disposed is within a radius of 300 mm from a radiating LED, if a contact-type sensor is used, and within 15 mm is a non contact-type sensor is used.

The number of LEDs or sensors used in the present invention can be more than one each. If the shortest distance among the various positions of sensors and LEDs is within the range of 300 mm (or 15 mm for noncontact sensors), the arrangement will be suitable for achieving good results in the present invention. A thermocouple or a platinum resistor, as examples, can be used as the contact-type sensor in the present invention, and an infrared ray detector or a thermopile, as examples, can be used as the noncontact-type sensor in the present invention.

In FIG. 2, 11 is an LED, 12 is a C-A thermocouple, 13 is an epoxy adhesive, 14 is a Au wire, 15 is a transparent coating resin, 16 is a terminal pin and 17 is a two pin header. In the embodiment illustrated in FIG. 2, LED 11 is bonded to a can type header 17, and the C-A thermocouple 12 is fixed with an epoxy adhesive 13 (e.g. "Araldite"). The LED and terminal pin 16 are connected with a Au wire 14, and this arrangement is coated with the transparent coating resin 15.

In operation, a temperature signal detected by LED lamp 11 is converted to a digital signal by the LED temperature measurement means 4 having a voltmeter and an A/D converter. The temperature information is input to computing unit 5 along with information from the measurement and control means for the LED driving current 2 and the measurement and control means for the LED applied voltage 3.

In the computing unit 5, a computing operation is performed in order to determine the emission wavelength energy based on the equation:

$$EWE = OB - \alpha \times AP - \beta \times DST, \quad (1)$$

wherein EWE is the emission wavelength energy, OB is the optical band gap at a standard temperature, AP is the applied power, and DST is the difference from a standard temperature.

# Explore Litigation Insights

Docket Alarm provides insights to develop a more informed litigation strategy and the peace of mind of knowing you're on top of things.

## Real-Time Litigation Alerts



Keep your litigation team up-to-date with **real-time alerts** and advanced team management tools built for the enterprise, all while greatly reducing PACER spend.

Our comprehensive service means we can handle Federal, State, and Administrative courts across the country.

## Advanced Docket Research



With over 230 million records, Docket Alarm's cloud-native docket research platform finds what other services can't. Coverage includes Federal, State, plus PTAB, TTAB, ITC and NLRB decisions, all in one place.

Identify arguments that have been successful in the past with full text, pinpoint searching. Link to case law cited within any court document via Fastcase.

## Analytics At Your Fingertips



Learn what happened the last time a particular judge, opposing counsel or company faced cases similar to yours.

Advanced out-of-the-box PTAB and TTAB analytics are always at your fingertips.

## API

Docket Alarm offers a powerful API (application programming interface) to developers that want to integrate case filings into their apps.

## LAW FIRMS

Build custom dashboards for your attorneys and clients with live data direct from the court.

Automate many repetitive legal tasks like conflict checks, document management, and marketing.

## FINANCIAL INSTITUTIONS

Litigation and bankruptcy checks for companies and debtors.

## E-DISCOVERY AND LEGAL VENDORS

Sync your system to PACER to automate legal marketing.