



US 20090275810A1

(19) **United States**

(12) **Patent Application Publication**

**Ayers et al.**

(10) **Pub. No.: US 2009/0275810 A1**

(43) **Pub. Date: Nov. 5, 2009**

(54) **PORTABLE MODULAR PC BASED SYSTEM FOR CONTINUOUS MONITORING OF BLOOD OXYGENATION AND RESPIRATORY PARAMETERS**

(75) Inventors: **Eric J. Ayers**, Alliquippa, PA (US);  
**Eric W. Starr**, Allison Park, PA (US)

Correspondence Address:  
**BLYNN L. SHIDELER**  
**THE BLK LAW GROUP**  
**3500 BROOKTREE ROAD, SUITE 200**  
**WEXFORD, PA 15090 (US)**

(73) Assignee: **STARR Life Sciences Corp.**,  
Oakmont, PA (US)

(21) Appl. No.: **12/485,902**

(22) Filed: **Jun. 16, 2009**

**Related U.S. Application Data**

(63) Continuation-in-part of application No. 12/434,599, filed on May 1, 2009.

(60) Provisional application No. 61/073,003, filed on Jun. 16, 2008, provisional application No. 61/049,451, filed on May 1, 2008.

**Publication Classification**

(51) **Int. Cl.**  
**A61B 5/00** (2006.01)  
**G08B 23/00** (2006.01)

(52) **U.S. Cl.** ..... **600/301; 340/573.1**

(57) **ABSTRACT**

A portable modular kiosk based physiologic sensor system for clinical and research applications configured to simultaneously utilize multiple sensors with cross checking and cross calculation of physiologic parameters and configured for continuous monitoring of blood oxygenation and respiratory parameters.

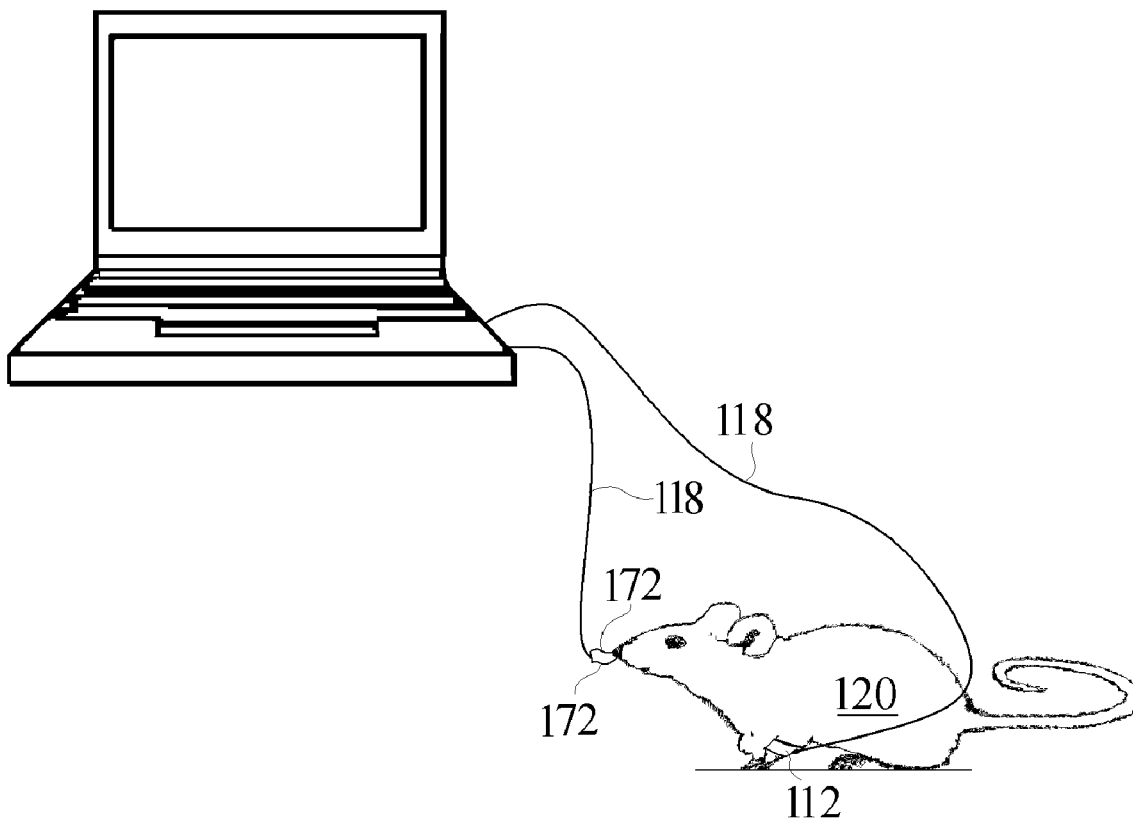

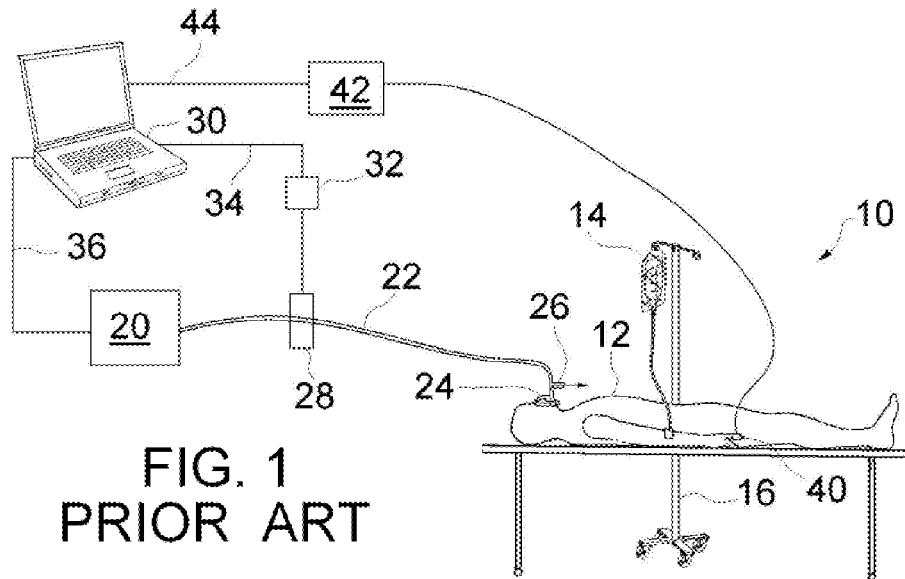

FIG. 1  
PRIOR ART

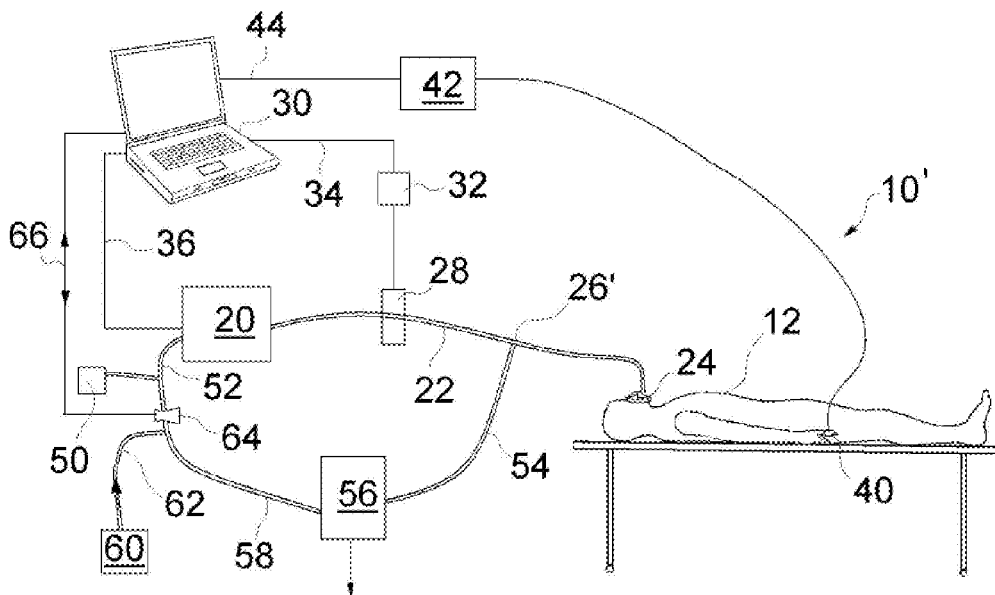

FIG. 2  
PRIOR ART

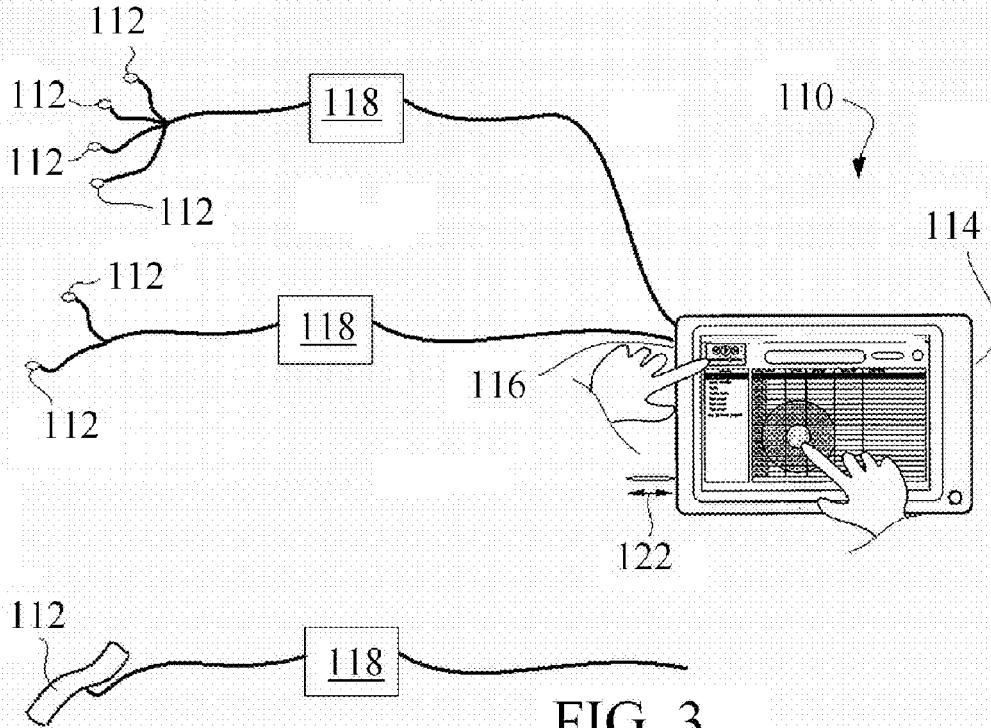
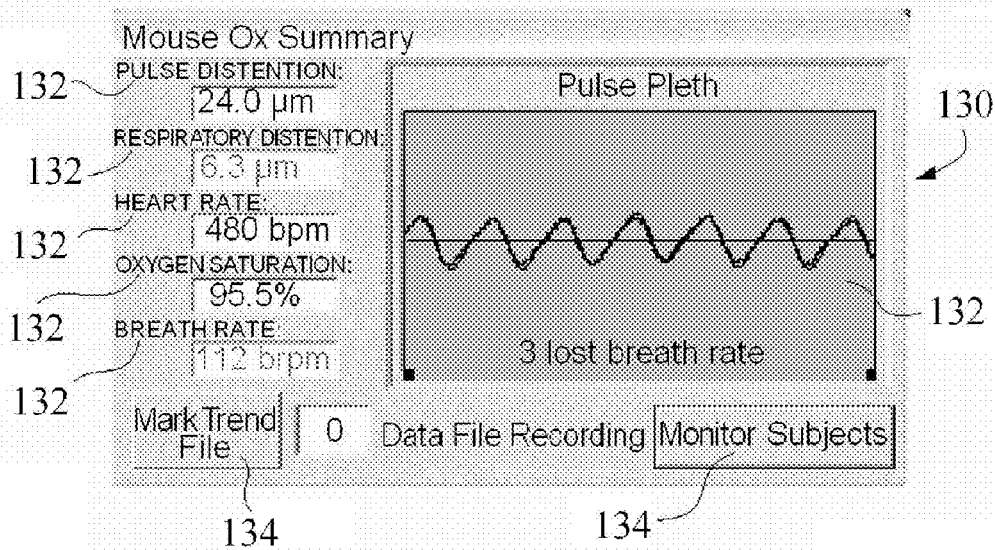
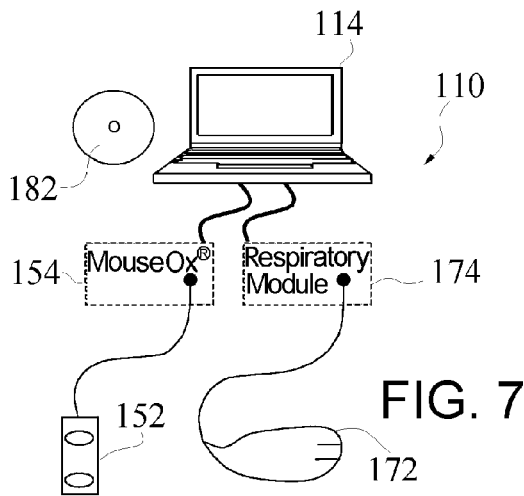
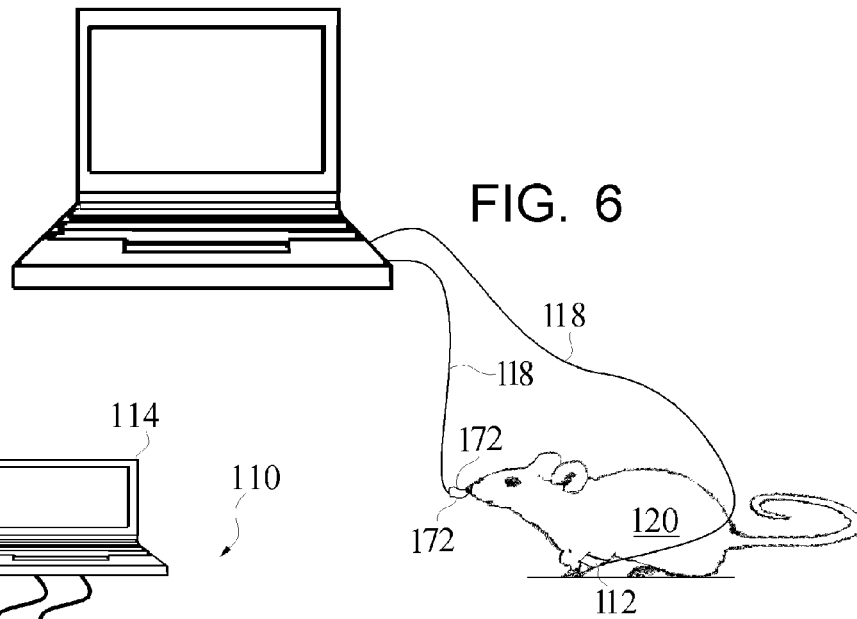
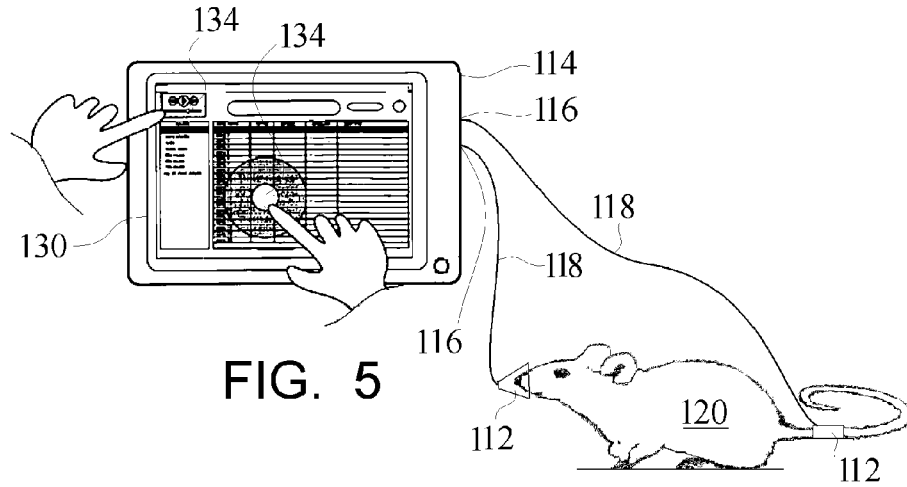

FIG. 3

FIG. 4





**PORTABLE MODULAR PC BASED SYSTEM  
FOR CONTINUOUS MONITORING OF  
BLOOD OXYGENATION AND RESPIRATORY  
PARAMETERS**

RELATED APPLICATIONS

**[0001]** The present application claims the benefit of U.S. Provisional Patent Application Ser. No. 61/073,003 entitled "Apparatus for Continuous Monitoring of Blood Oxygenation and Respiratory Parameters" filed Jun. 16, 2008.

**[0002]** The present application is a continuation in part of U.S. patent application Ser. No. 12/434,599 entitled "Portable Modular Kiosk Based Physiologic Sensor System with Display and Data Storage for Clinical and Research Applications including Cross Calculating and Cross Checked Physiologic Parameters Based Upon Combined Sensor Input" filed May 1, 2009.

**[0003]** U.S. patent application Ser. No. 12/434,599 claims the benefit of U.S. Provisional Patent Application Ser. No. 61/049,451 entitled "Portable Modular Kiosk Based Physiologic Sensor System for Clinical and Research Applications Configured to Simultaneously Utilize Multiple Sensors with Cross Checking and Cross Calculation of Physiologic Parameters" filed May 1, 2008.

BACKGROUND OF THE INVENTION

**[0004]** 1. Field of the Invention

**[0005]** The present invention relates to a portable, modular physiologic sensor system with display and data storage for clinical and research applications, in particular to small mammal applications, such as neonates in humans and rats and mice in research applications, for continuous monitoring of blood oxygenation and respiratory parameters.

**[0006]** 2. Background Information

**[0007]** The present invention relates to monitoring of physiologic parameters of a patient or subject, in particular an animal patient or subject, such as a small mammal, such as neonates in humans and rats and mice in research applications. The following definitions will be helpful in explaining the known background elements that are helpful for understanding the present invention. Physiologic parameters are measured with physiologic sensors that typically, but not always, contact the patient or subject. The term patient is appropriate in the medical fields for both the human medical field and animal veterinarian fields. The term subject is appropriate in the research field, and the term subject will apply to human and non-human applications.

**[0008]** The list of physiologic sensors is large and constantly growing. A representative list of physiologic sensors known in the art include blood pressure sensors, blood flow sensors, blood glucose sensors, blood cholesterol sensors, heart sound sensors, EMG sensors, EEG sensors, EKG sensors, EOG sensors, pulse sensors, oxygenation sensors, blood perfusion sensors, respiration monitors, temperature sensors, blood gas sensors, motion sensors, strain gauges, body position sensors, and limb motion sensors.

**[0009]** A "kiosk" within this application, sometimes called an electronic kiosk, computer kiosk or interactive kiosk, houses a computer terminal that often employs custom kiosk software designed to function, hopefully flawlessly, while preventing users from accessing system functions. "Kiosk

from a computer network. Some common computer kiosks provide a free, informational public service while others common computer kiosks serve a commercial purpose. Touchscreens, trackballs, computer keyboards, and pushbuttons are all typical input devices for interactive computer kiosk.

**[0010]** The "personal computer" or simply "PC" is a term that is so often used it seems unlikely, at first, to require formal definition. However the precise scope of the term is sometimes vague. A PC is a computer whose size, and capabilities (and some have said price) make it useful for individuals, intended to be operated directly by an end user and capable of performing a variety of general purpose tasks, with no intervening computer operator. The PC may be a home computer, or may be found in an office, a medical facility or a research lab. The PC may often be connected to a local area network. The distinguishing characteristics of a PC are that the computer is primarily used, interactively, by one person at a time. This is opposite to the batch processing or time-sharing models which allowed large expensive systems to be used by many people, usually at the same time, or large data processing systems which required a full-time staff to operate. The PC can come in desktop models, notebook models, handheld models, and hybrids of these.

**[0011]** A "notebook computer", or simply "notebook" within this application, is an extremely lightweight PC. Notebook computers typically weigh less than 6 pounds and are small enough to fit easily in a briefcase. Aside from size and portability, the principal difference between a notebook computer and a non-notebook personal computer (e.g. a desktop computer) is the display screen. Notebook computers use a variety of techniques, known as flat-pane technologies, to produce a lightweight and non-bulky display screen. Laptop computers and tablet PCs are two types of notebook computers. Usually all of the interface hardware needed to operate the notebook computer, such as parallel and serial ports, graphics card, sound channel, etc., are built in to a single unit. Most notebook computers contain batteries to facilitate operation without a readily available electrical outlet.

**[0012]** A "laptop computer", or simply laptop, is, within this application, a subset of notebooks. A laptop will have a display and separate keyboard interface (e.g. "qwerty" keyboard), with the keyboard and the display typically hinged together. The term Laptop is sometimes used more broadly and equated with notebooks, but the term will have a narrower definition within this application.

**[0013]** A "Tablet PC" is a notebook, also called a panel computer, and was first introduced by Pen Computing in the early 90s with their PenGo Tablet Computer and popularized by Microsoft. The touch-screen or "graphics tablet/screen hybrid technology" technology of the tablet PHOTOCHROMIC allows the user to operate the computer with a stylus or digital pen, or a fingertip, instead of a keyboard or mouse. The tablet PC is particularly well suited to operate in Kiosk mode in light of the built in user interface provided with the tablet PC.

**[0014]** The input/output ports of a personal computer refer to the communications links through which the personal computers send and receive information, which generally include serial ports, parallel ports, wireless links or connectors (such as WI-FI and Bluetooth), and universal serial bus (USB) ports. In addition, some laptops have expansion slots for

# Explore Litigation Insights

Docket Alarm provides insights to develop a more informed litigation strategy and the peace of mind of knowing you're on top of things.

## Real-Time Litigation Alerts



Keep your litigation team up-to-date with **real-time alerts** and advanced team management tools built for the enterprise, all while greatly reducing PACER spend.

Our comprehensive service means we can handle Federal, State, and Administrative courts across the country.

## Advanced Docket Research



With over 230 million records, Docket Alarm's cloud-native docket research platform finds what other services can't. Coverage includes Federal, State, plus PTAB, TTAB, ITC and NLRB decisions, all in one place.

Identify arguments that have been successful in the past with full text, pinpoint searching. Link to case law cited within any court document via Fastcase.

## Analytics At Your Fingertips



Learn what happened the last time a particular judge, opposing counsel or company faced cases similar to yours.

Advanced out-of-the-box PTAB and TTAB analytics are always at your fingertips.

## API

Docket Alarm offers a powerful API (application programming interface) to developers that want to integrate case filings into their apps.

## LAW FIRMS

Build custom dashboards for your attorneys and clients with live data direct from the court.

Automate many repetitive legal tasks like conflict checks, document management, and marketing.

## FINANCIAL INSTITUTIONS

Litigation and bankruptcy checks for companies and debtors.

## E-DISCOVERY AND LEGAL VENDORS

Sync your system to PACER to automate legal marketing.