

Doc Code: PA..

Document Description: Power of Attorney

PTO/AIA/82A (07-12)

Approved for use through 11/30/2014. OMB 0651-0035
U.S. Patent and Trademark Office; U.S. DEPARTMENT OF COMMERCE

Under the Paperwork Reduction Act of 1995, no persons are required to respond to a collection of information unless it displays a valid OMB control number.

TRANSMITTAL FOR POWER OF ATTORNEY TO ONE OR MORE REGISTERED PRACTITIONERS

NOTE: This form is to be submitted with the Power of Attorney by Applicant form (PTO/AIA/82B or equivalent) to identify the application to which the Power of Attorney is directed, in accordance with 37 CFR 1.5. If the Power of Attorney by Applicant form is not accompanied by this transmittal form or an equivalent, the Power of Attorney will not be recognized in the application.

Application Number	Unknown
Filing Date	Herewith
First Named Inventor	Ammar Al-Ali
Title	ADVANCED PULSE OXIMETRY SENSOR
Art Unit	Unknown
Examiner Name	Unknown
Attorney Docket Number	MASIMO.1007A

SIGNATURE of Applicant or Patent Practitioner

Signature	/Jarom Kesler/	Date	2016-06-28
Name	Jarom Kesler	Telephone	949-760-0404
Registration Number	57,046		

NOTE: This form must be signed in accordance with 37 CFR 1.33. See 37 CFR 1.4(d) for signature requirements and certifications.

*Total of 1 forms are submitted.

This collection of information is required by 37 CFR 1.31, 1.32 and 1.33. The information is required to obtain or retain a benefit by the public which is to file (and by the USPTO to process) an application. Confidentiality is governed by 35 U.S.C. 122 and 37 CFR 1.11 and 1.14. This collection is estimated to take 3 minutes to complete, including gathering, preparing, and submitting the completed application form to the USPTO. Time will vary depending upon the individual case. Any comments on the amount of time you require to complete this form and/or suggestions for reducing this burden, should be sent to the Chief Information Officer, U.S. Patent and Trademark Office, U.S. Department of Commerce, P.O. Box 1450, Alexandria, VA 22313-1450. DO NOT SEND FEES OR COMPLETED FORMS TO THIS ADDRESS. **SEND TO: Commissioner for Patents, P.O. Box 1450, Alexandria, VA 22313-1450.**

If you need assistance in completing the form, call 1-800-PTO-9199 and select option 2.

Doc Code: PA..

Document Description: Power of Attorney

PTO/AIA/82B(07-12)

Approved for use through 11/30/2014. OMB 0651-0035

U.S. Patent and Trademark Office; U.S. DEPARTMENT OF COMMERCE

Under the Paperwork Reduction Act of 1995, no persons are required to respond to a collection of information unless it displays a valid OMB control number.

POWER OF ATTORNEY BY APPLICANT

I hereby revoke all previous powers of attorney given in the application identified in the attached transmittal letter.

I hereby appoint Practitioner(s) associated with the following Customer Number as my/our attorney(s) or agent(s), and to transact all business in the United States Patent and Trademark Office connected therewith for the application referenced in the attached transmittal letter (form PTO/AIA/82A or equivalent):

64735

OR

I hereby appoint Practitioner(s) named below as my/our attorney(s) or agent(s), and to transact all business in the United States Patent and Trademark Office connected therewith for the application referenced in the attached transmittal letter (form PTO/AIA/82A or equivalent):

Name	Registration Number	Name	Registration Number

Please recognize or change the correspondence address for the application identified in the attached transmittal letter to:

The address associated with the above-mentioned Customer Number.

OR

The address associated with Customer Number:

[Empty box for alternate address]

OR

Firm or Individual Name

Address

City

State

Zip

Country

Telephone

Email

I am the Applicant:

Inventor or Joint Inventor

Legal Representative of a Deceased or Legally Incapacitated Inventor

Assignee or Person to Whom the Inventor is Under an Obligation to Assign

Person Who Otherwise Shows Sufficient Proprietary Interest (e.g., a petition under 37 CFR 1.46(b)(2) was granted in the application or is concurrently being filed with this document)

SIGNATURE of Applicant for Patent

Signature

Thomas McClenahan

Date

7/13/13

Name

Thomas McClenahan

Telephone

(949) 297-7000

Title and Company

Executive Vice President and General Counsel, Masimo Corporation

NOTE: Signature - This form must be signed by the applicant in accordance with 37 CFR 1.33. See 37 CFR 1.4 for signature requirements and certifications. Submit multiple forms for more than one signature, see below.

*Total of 1 forms are submitted.

This collection of information is required by 37 CFR 1.31, 1.32 and 1.33. The information is required to obtain or retain a benefit by the public which is to file (and by the USPTO to process) an application. Confidentiality is governed by 35 U.S.C. 122 and 37 CFR 1.11 and 1.14. This collection is estimated to take 3 minutes to complete, including gathering, preparing, and submitting the completed application form to the USPTO. Time will vary depending upon the individual case. Any comments on the amount of time you require to complete this form and/or suggestions for reducing this burden, should be sent to the Chief Information Officer, U.S. Patent and Trademark Office, U.S. Department of Commerce, P.O. Box 1450, Alexandria, VA 22313-1450. DO NOT SEND FEES OR COMPLETED FORMS TO THIS ADDRESS. SEND TO: Commissioner for Patents, P.O. Box 1450, Alexandria, VA 22313-1450.

If you need assistance in completing the form, call 1-800-PTO-9199 and select option 2.

Privacy Act Statement

The **Privacy Act of 1974 (P.L. 93-579)** requires that you be given certain information in connection with your submission of the attached form related to a patent application or patent. Accordingly, pursuant to the requirements of the Act, please be advised that: (1) the general authority for the collection of this information is 35 U.S.C. 2(b)(2); (2) furnishing of the information solicited is voluntary; and (3) the principal purpose for which the information is used by the U.S. Patent and Trademark Office is to process and/or examine your submission related to a patent application or patent. If you do not furnish the requested information, the U.S. Patent and Trademark Office may not be able to process and/or examine your submission, which may result in termination of proceedings or abandonment of the application or expiration of the patent.

The information provided by you in this form will be subject to the following routine uses:

1. The information on this form will be treated confidentially to the extent allowed under the Freedom of Information Act (5 U.S.C. 552) and the Privacy Act (5 U.S.C. 552a). Records from this system of records may be disclosed to the Department of Justice to determine whether disclosure of these records is required by the Freedom of Information Act.
2. A record from this system of records may be disclosed, as a routine use, in the course of presenting evidence to a court, magistrate, or administrative tribunal, including disclosures to opposing counsel in the course of settlement negotiations.
3. A record in this system of records may be disclosed, as a routine use, to a Member of Congress submitting a request involving an individual, to whom the record pertains, when the individual has requested assistance from the Member with respect to the subject matter of the record.
4. A record in this system of records may be disclosed, as a routine use, to a contractor of the Agency having need for the information in order to perform a contract. Recipients of information shall be required to comply with the requirements of the Privacy Act of 1974, as amended, pursuant to 5 U.S.C. 552a(m).
5. A record related to an International Application filed under the Patent Cooperation Treaty in this system of records may be disclosed, as a routine use, to the International Bureau of the World Intellectual Property Organization, pursuant to the Patent Cooperation Treaty.
6. A record in this system of records may be disclosed, as a routine use, to another federal agency for purposes of National Security review (35 U.S.C. 181) and for review pursuant to the Atomic Energy Act (42 U.S.C. 218(c)).
7. A record from this system of records may be disclosed, as a routine use, to the Administrator, General Services, or his/her designee, during an inspection of records conducted by GSA as part of that agency's responsibility to recommend improvements in records management practices and programs, under authority of 44 U.S.C. 2904 and 2906. Such disclosure shall be made in accordance with the GSA regulations governing inspection of records for this purpose, and any other relevant (*i.e.*, GSA or Commerce) directive. Such disclosure shall not be used to make determinations about individuals.
8. A record from this system of records may be disclosed, as a routine use, to the public after either publication of the application pursuant to 35 U.S.C. 122(b) or issuance of a patent pursuant to 35 U.S.C. 151. Further, a record may be disclosed, subject to the limitations of 37 CFR 1.14, as a routine use, to the public if the record was filed in an application which became abandoned or in which the proceedings were terminated and which application is referenced by either a published application, an application open to public inspection or an issued patent.
9. A record from this system of records may be disclosed, as a routine use, to a Federal, State, or local law enforcement agency, if the USPTO becomes aware of a violation or potential violation of law or regulation.

Docket No.: MASIMO.1007A

Customer No. 64735

INFORMATION DISCLOSURE STATEMENT

First Inventor :	Ammar Al-Ali		
App. No. :	Unknown		
Filed :	Herewith		
For :	ADVANCED	PULSE	OXIMETRY
	SENSOR		
Examiner :	Unknown		
Art Unit :	Unknown		
Conf. No. :	Unknown		

Commissioner for Patents
P.O. Box 1450
Alexandria, VA 22313-1450

References and Listing

Pursuant to 37 CFR 1.56, an Information Disclosure Statement listing references is provided herewith. Copies of any listed foreign and non-patent literature references are being submitted.

No Disclaimers

To the extent that anything in the Information Disclosure Statement or the listed references could be construed as a disclaimer of any subject matter supported by the present application, Applicant hereby rescinds and retracts such disclaimer.

Timing of Disclosure

This Information Disclosure Statement is being filed within three months of the filing date or date of national phase entry, with an RCE or before receipt of a First Office Action after an RCE, and no fee is believed to be required.

PTO/SB/08 Equivalent

INFORMATION DISCLOSURE STATEMENT BY APPLICANT	Application No.	Unknown	
	Filing Date	Herewith	
	First Named Inventor	Ammar Al-Ali	
	Art Unit	Unknown	
<i>(Multiple sheets used when necessary)</i>		Examiner	Unknown
SHEET 1 OF 24		Attorney Docket No.	MASIMO.1007A

U.S. PATENT DOCUMENTS

Examiner Initials	Cite No.	Document Number <i>Number - Kind Code (if known)</i> Example: 1,234,567 B1	Publication Date MM-DD-YYYY	Name of Patentee or Applicant	Pages, Columns, Lines Where Relevant Passages or Relevant Figures Appear
	1	9,351,675	05/31/2016	Al-Ali et al.	
	2	9,351,673	05/31/2016	Diab et al.	
	3	2016/0143548	05/26/2016	Al-Ali	
	4	2016/0051205	02/25/2016	Al-Ali et al.	
	5	9,341,565	05/17/2016	Lamego et al.	
	6	9,339,220	05/17/2016	Lamego et al.	
	7	9,333,316	05/10/2016	Kiani	
	8	D755,392	05/03/2016	Hwang et al.	
	9	9,326,712	05/03/2016	Kiani	
	10	2016/0113527	04/28/2016	Al-Ali et al.	
	11	9,323,894	04/26/2016	Kiani	
	12	2016/0103598	04/14/2016	Al-Ali et al.	
	13	9,307,928	04/12/2016	Al-Ali et al.	
	14	2016/0095548	04/07/2016	Al-Ali et al.	
	15	2016/0095543	04/07/2016	Telfort et al.	
	16	9,295,421	03/29/2016	Kiani et al.	
	17	2016/0081552	03/24/2016	Wojtczuk et al.	
	18	9,289,167	03/22/2016	Diab et al.	
	19	2016/0073967	03/17/2016	Lamego et al.	
	20	2016/0072429	03/10/2016	Kiani et al.	
	21	2016/0066879	03/10/2016	Telfort et al.	
	22	2016/0066824	03/10/2016	Al-Ali et al.	
	23	2016/0066823	03/10/2016	Kind et al.	
	24	9,277,880	03/08/2016	Poeze et al.	
	25	2016/0058347	03/03/2016	Reichgott et al.	
	26	2016/0058338	03/03/2016	Schurman et al.	
	27	9,267,572	02/23/2016	Barker et al.	
	28	2016/0045118	02/18/2016	Kiani	
	29	9,259,185	02/16/2016	Abdul-Hafiz et al.	

Examiner Signature	Date Considered
<p>*Examiner: Initial if reference considered, whether or not citation is in conformance with MPEP 609. Draw line through citation if not in conformance and not considered. Include copy of this form with next communication to applicant.</p>	

T¹ - Place a check mark in this area when an English language Translation is attached.

PTO/SB/08 Equivalent

INFORMATION DISCLOSURE STATEMENT BY APPLICANT	Application No.	Unknown	
	Filing Date	Herewith	
	First Named Inventor	Ammar Al-Ali	
	Art Unit	Unknown	
<i>(Multiple sheets used when necessary)</i>		Examiner	Unknown
SHEET 2 OF 24		Attorney Docket No.	MASIMO.1007A

U.S. PATENT DOCUMENTS

Examiner Initials	Cite No.	Document Number <i>Number - Kind Code (if known)</i> Example: 1,234,567 B1	Publication Date MM-DD-YYYY	Name of Patentee or Applicant	Pages, Columns, Lines Where Relevant Passages or Relevant Figures Appear
	30	2016/0029933	02/04/2016	Al-Ali et al.	
	31	2016/0029932	02/04/2016	Al-Ali	
	32	9,245,668	01/26/2016	Vo et al.	
	33	9,241,662	01/26/2016	Al-Ali et al.	
	34	2016/0007930	01/14/2016	Weber et al.	
	35	2016/0000362	01/07/2016	Diab et al.	
	36	9,226,696	01/05/2016	Kiani	
	37	2015/0380875	12/31/2015	Coverston et al.	
	38	2015/0374298	12/31/2015	Al-Ali et al.	
	39	2015/0366507	12/24/2015	Blank	
	40	2015/0366472	12/24/2015	Kiani	
	41	9,218,454	12/22/2015	Kiani et al.	
	42	9,211,095	12/15/2015	Al-Ali	
	43	9,211,072	12/15/2015	Kiani	
	44	2015/0359429	12/17/2015	Al-Ali et al.	
	45	2015/0351704	12/20/2015	Kiani et al.	
	46	2015/0351697	12/10/2015	Weber et al.	
	47	9,195,385	11/24/2015	Al-Ali et al.	
	48	9,192,351	11/24/2015	Telfort et al.	
	49	9,192,329	11/24/2015	Al-Ali	
	50	9,192,312	11/24/2015	Al-Ali	
	51	9,186,102	11/17/2015	Bruinsma et al.	
	52	9,176,141	11/03/2015	Al-Ali et al.	
	53	9,167,995	10/27/2015	Lamego et al.	
	54	9,161,713	10/20/2015	Al-Ali et al.	
	55	9,161,696	10/20/2015	Al-Ali et al.	
	56	9,153,121	10/06/2015	Kiani et al.	
	57	9,153,112	10/06/2015	Kiani et al.	
	58	2015/0272514	10/01/2015	Kiani et al.	

Examiner Signature	Date Considered
<p>*Examiner: Initial if reference considered, whether or not citation is in conformance with MPEP 609. Draw line through citation if not in conformance and not considered. Include copy of this form with next communication to applicant.</p>	

T¹ - Place a check mark in this area when an English language Translation is attached.

PTO/SB/08 Equivalent

INFORMATION DISCLOSURE STATEMENT BY APPLICANT	Application No.	Unknown	
	Filing Date	Herewith	
	First Named Inventor	Ammar Al-Ali	
	Art Unit	Unknown	
<i>(Multiple sheets used when necessary)</i>		Examiner	Unknown
SHEET 3 OF 24		Attorney Docket No.	MASIMO.1007A

U.S. PATENT DOCUMENTS

Examiner Initials	Cite No.	Document Number <i>Number - Kind Code (if known)</i> Example: 1,234,567 B1	Publication Date MM-DD-YYYY	Name of Patentee or Applicant	Pages, Columns, Lines Where Relevant Passages or Relevant Figures Appear
	59	9,142,117	09/22/2015	Muhsin et al.	
	60	9,138,192	09/22/2015	Weber et al.	
	61	9,138,182	09/22/2015	Al-Ali et al.	
	62	9,138,180	09/22/2015	Coverston et al.	
	63	2015/0257689	09/17/2015	Al-Ali et al.	
	64	9,131,917	09/15/2015	Telfort et al.	
	65	9,131,883	09/15/2015	Al-Ali	
	66	9,131,882	09/15/2015	Al-Ali et al.	
	67	9,131,881	09/15/2015	Diab et al.	
	68	2015/0245794	09/03/2015	Al-Ali	
	69	2015/0245773	09/03/2015	Lamego et al.	
	70	2015/0245793	09/02/2015	Al-Ali et al.	
	71	9,119,595	09/01/2015	Lamego	
	72	2015/0238722	08/27/2015	Al-Ali	
	73	9,113,832	08/25/2015	Al-Ali	
	74	9,113,831	08/25/2015	Al-Ali	
	75	2015/0230755	08/20/2015	Al-Ali et al.	
	76	9,107,626	08/18/2015	Al-Ali et al.	
	77	9,107,625	08/18/2015	Telfort et al.	
	78	9,106,038	08/11/2015	Telfort et al.	
	79	2015/0216459	08/06/2015	Al-Ali et al.	
	80	9,095,316	08/04/2015	Welch et al.	
	81	2015/0208966	07/30/2015	Al-Ali	
	82	2015/0201874	07/23/2015	Diab	
	83	9,084,569	07/21/2015	Weber et al.	
	84	2015/0196237	07/16/2015	Lamego	
	85	9,078,560	07/14/2015	Schurman et al.	
	86	9,072,474	07/07/2015	Al-Ali et al.	
	87	9,066,680	06/30/2015	Al-Ali et al.	

Examiner Signature	Date Considered
<p>*Examiner: Initial if reference considered, whether or not citation is in conformance with MPEP 609. Draw line through citation if not in conformance and not considered. Include copy of this form with next communication to applicant.</p>	

T¹ - Place a check mark in this area when an English language Translation is attached.

PTO/SB/08 Equivalent

INFORMATION DISCLOSURE STATEMENT BY APPLICANT	Application No.	Unknown	
	Filing Date	Herewith	
	First Named Inventor	Ammar Al-Ali	
	Art Unit	Unknown	
<i>(Multiple sheets used when necessary)</i>		Examiner	Unknown
SHEET 4 OF 24		Attorney Docket No.	MASIMO.1007A

U.S. PATENT DOCUMENTS					
Examiner Initials	Cite No.	Document Number <i>Number - Kind Code (if known)</i> Example: 1,234,567 B1	Publication Date MM-DD-YYYY	Name of Patentee or Applicant	Pages, Columns, Lines Where Relevant Passages or Relevant Figures Appear
	88	9,066,666	06/30/2015	Kiani	
	89	9,060,721	06/23/2015	Reichgott et al.	
	90	2015/0165312	06/18/2015	Kiani	
	91	2015/0141781	05/21/2015	Weber et al.	
	92	2015/0140863	05/21/2015	Al-Ali et al.	
	93	9,037,207	05/19/2015	Al-Ali et al.	
	94	2015/0133755	05/14/2015	Smith et al.	
	95	9,028,429	05/12/2015	Telfort et al.	
	96	2015/0126830	5/07/2015	Schurman et al.	
	97	2015/0116076	4/30/2015	Al-Ali et al.	
	98	2015/0112151	04/23/2015	Muhsin et al.	
	99	2015/0106121	04/16/2015	Muhsin et al.	
	100	2015/0101844	04/16/2015	Al-Ali et al.	
	101	2015/0099955	04/09/2015	Al-Ali et al.	
	102	2015/0099951	04/09/2015	Al-Ali et al.	
	103	2015/0099950	04/09/2015	Al-Ali et al.	
	104	2015/0097701	04/09/2015	Al-Ali et al.	
	105	2015/0099324	04/09/2015	Wojtczuk et al.	
	106	8,998,809	04/07/2015	Kiani	
	107	2015/0094546	04/02/2015	Al-Ali	
	108	8,996,085	03/31/2015	Kiani et al.	
	109	2015/0087936	03/26/2015	Al-Ali et al.	
	110	8,989,831	03/24/2015	Al-Ali et al.	
	111	2015/0080754	03/19/2015	Purdon et al.	
	112	8,983,564	03/17/2015	Al-Ali	
	113	8,965,471	02/24/2015	Lamego	
	114	2015/0051462	02/19/2015	Olsen	
	115	2015/0045685	02/12/2015	Al-Ali et al.	
	116	2015/0045637	02/12/2015	Dalvi	

Examiner Signature	Date Considered
<p>*Examiner: Initial if reference considered, whether or not citation is in conformance with MPEP 609. Draw line through citation if not in conformance and not considered. Include copy of this form with next communication to applicant.</p>	

T¹ - Place a check mark in this area when an English language Translation is attached.

PTO/SB/08 Equivalent

INFORMATION DISCLOSURE STATEMENT BY APPLICANT	Application No.	Unknown	
	Filing Date	Herewith	
	First Named Inventor	Ammar Al-Ali	
	Art Unit	Unknown	
<i>(Multiple sheets used when necessary)</i>		Examiner	Unknown
SHEET 5 OF 24		Attorney Docket No.	MASIMO.1007A

U.S. PATENT DOCUMENTS

Examiner Initials	Cite No.	Document Number <i>Number - Kind Code (if known)</i> Example: 1,234,567 B1	Publication Date MM-DD-YYYY	Name of Patentee or Applicant	Pages, Columns, Lines Where Relevant Passages or Relevant Figures Appear
	117	2015/0038859	02/05/2015	Dalvi et al.	
	118	8,948,835	02/03/2015	Diab	
	119	8,948,834	02/03/2015	Diab et al.	
	120	2015/0032029	01/29/2015	Al-Ali et al.	
	121	8,942,777	01/27/2015	Diab et al.	
	122	2015/0025406	01/22/2015	Al-Ali	
	123	2015/0018650	01/15/2015	Al-Ali et al.	
	124	2015/0012231	01/08/2015	Poeze et al.	
	125	2015/0011907	01/08/2015	Purdon et al.	
	126	8,929,964	01/06/2015	Al-Ali et al.	
	127	2015/0005600	01/01/2015	Blank et al.	
	128	8,922,382	12/30/2014	Al-Ali et al.	
	129	8,921,699	12/30/2014	Al-Ali et al.	
	130	8,920,317	12/30/2014	Al-Ali et al.	
	131	2014/0378784	12/25/2014	Kiani et al.	
	132	2014/0371548	12/28/2014	Al-Ali et al.	
	133	2014/0371632	12/18/2014	Al-Ali et al.	
	134	8,912,909	12/16/2014	Al-Ali et al.	
	135	8,911,377	12/16/2014	Al-Ali	
	136	8,909,310	12/09/2014	Lamego et al.	
	137	2014/0357966	12/04/2014	Al-Ali et al.	
	138	8,897,847	11/25/2014	Al-Ali	
	139	8,892,180	11/18/2014	Weber et al.	
	140	8,888,708	11/18/2014	Diab et al.	
	141	8,888,539	11/18/2014	Al-Ali et al.	
	142	2014/0336481	11/13/2014	Shakespeare et al.	
	143	8,886,271	11/11/2014	Kiani et al.	
	144	2014/0330099	11/06/2014	Al-Ali et al.	
	145	2014/0330098	11/06/2014	Merritt et al.	

Examiner Signature	Date Considered
<p>*Examiner: Initial if reference considered, whether or not citation is in conformance with MPEP 609. Draw line through citation if not in conformance and not considered. Include copy of this form with next communication to applicant.</p>	

T¹ - Place a check mark in this area when an English language Translation is attached.

PTO/SB/08 Equivalent

INFORMATION DISCLOSURE STATEMENT BY APPLICANT	Application No.	Unknown	
	Filing Date	Herewith	
	First Named Inventor	Ammar Al-Ali	
	Art Unit	Unknown	
<i>(Multiple sheets used when necessary)</i>		Examiner	Unknown
SHEET 6 OF 24		Attorney Docket No.	MASIMO.1007A

U.S. PATENT DOCUMENTS					
Examiner Initials	Cite No.	Document Number <i>Number - Kind Code (if known)</i> Example: 1,234,567 B1	Publication Date MM-DD-YYYY	Name of Patentee or Applicant	Pages, Columns, Lines Where Relevant Passages or Relevant Figures Appear
	146	2014/0330092	11/06/2014	Al-Ali et al.	
	147	2014/0323898	10/30/2014	Purdon et al.	
	148	2014/0323897	10/30/2014	Brown et al.	
	149	2014/0323825	10/30/2014	Al-Ali et al.	
	150	8,870,792	10/28/2014	Al-Ali et al.	
	151	2014/0316218	10/23/2014	Purdon et al.	
	152	2014/0316217	10/23/2014	Purdon et al.	
	153	8,868,150	10/21/2014	Al-Ali et al.	
	154	8,868,147	10/21/2014	Stippick et al.	
	155	2014/0316228	10/23/2014	Blank et al.	
	156	8,852,994	10/07/2014	Wojtczuk et al.	
	157	2014/0303520	10/09/2014	Telfort et al.	
	158	8,852,094	10/07/2014	Al-Ali et al.	
	159	8,849,365	09/30/2014	Smith et al.	
	160	8,847,740	09/30/2014	Kiani et al.	
	161	8,845,543	09/30/2014	Diab et al.	
	162	8,840,549	09/23/2014	Al-Ali et al.	
	163	8,831,700	09/09/2014	Schurman et al.	
	164	8,830,449	09/09/2014	Lamego et al.	
	165	2014/0288400	09/25/2014	Diab et al.	
	166	2014/0276115	09/18/2014	Dalvi et al.	
	167	2014/0275881	09/18/2014	Lamego et al.	
	168	2014/0275872	09/18/2014	Merritt et al.	
	169	2014/0275871	09/18/2014	Lamego et al.	
	170	2014/0275835	09/18/2014	Lamego et al.	
	171	2014/0275808	09/18/2014	Poeze et al.	
	172	8,821,415	09/02/2014	Al-Ali et al.	
	173	2014/0266790	09/18/2014	Al-Ali et al.	
	174	8,821,397	09/02/2014	Al-Ali et al.	

Examiner Signature	Date Considered
<p>*Examiner: Initial if reference considered, whether or not citation is in conformance with MPEP 609. Draw line through citation if not in conformance and not considered. Include copy of this form with next communication to applicant.</p>	

T¹ - Place a check mark in this area when an English language Translation is attached.

INFORMATION DISCLOSURE STATEMENT BY APPLICANT	Application No.	Unknown	
	Filing Date	Herewith	
	First Named Inventor	Ammar Al-Ali	
	Art Unit	Unknown	
<i>(Multiple sheets used when necessary)</i>		Examiner	Unknown
SHEET 7 OF 24		Attorney Docket No.	MASIMO.1007A

U.S. PATENT DOCUMENTS

Examiner Initials	Cite No.	Document Number <i>Number - Kind Code (if known)</i> Example: 1,234,567 B1	Publication Date MM-DD-YYYY	Name of Patentee or Applicant	Pages, Columns, Lines Where Relevant Passages or Relevant Figures Appear
	175	8,801,613	08/12/2014	Al-Ali et al.	
	176	8,790,268	07/29/2014	Al-Ali	
	177	8,788,003	07/22/2014	Schurman et al.	
	178	8,781,549	07/15/2014	Al-Ali et al.	
	179	8,781,544	07/15/2014	Al-Ali et al.	
	180	2014/0213864	07/31/2014	Abdul-Hafiz et al.	
	181	8,781,543	07/15/2014	Diab et al.	
	182	2014/0206963	07/24/2014	Al-Ali	
	183	8,777,634	07/15/2014	Kiani et al.	
	184	8,771,204	07/08/2014	Telfort et al.	
	185	2014/0187973	07/03/2014	Brown et al.	
	186	2014/0194766	07/10/2014	Al-Ali et al.	
	187	8,768,423	07/01/2014	Shakespeare et al.	
	188	8,764,671	07/01/2014	Kiani	
	189	2014/0180160	06/26/2014	Brown et al.	
	190	8,761,850	06/24/2014	Lamego	
	191	8,755,872	06/17/2014	Marinow	
	192	8,755,856	06/17/2014	Diab et al.	
	193	2014/0180154	06/26/2014	Sierra et al.	
	194	2014/0180038	06/26/2014	Kiani	
	195	8,755,535	06/17/2014	Telfort et al.	
	196	2014/0171763	06/19/2014	Diab	
	197	2014/0166076	06/19/2014	Kiani et al.	
	198	8,754,776	06/17/2014	Poeze et al.	
	199	2014/0163402	06/12/2014	Lamego et al.	
	200	2014/0163344	06/12/2014	Al-Ali	
	201	8,740,792	06/03/2014	Kiani et al.	
	202	8,723,677	05/13/2014	Kiani	
	203	8,721,542	05/13/2014	Al-Ali et al.	

Examiner Signature	Date Considered
<p>*Examiner: Initial if reference considered, whether or not citation is in conformance with MPEP 609. Draw line through citation if not in conformance and not considered. Include copy of this form with next communication to applicant.</p>	

T¹ - Place a check mark in this area when an English language Translation is attached.

INFORMATION DISCLOSURE STATEMENT BY APPLICANT	Application No.	Unknown	
	Filing Date	Herewith	
	First Named Inventor	Ammar Al-Ali	
	Art Unit	Unknown	
<i>(Multiple sheets used when necessary)</i>		Examiner	Unknown
SHEET 8 OF 24		Attorney Docket No.	MASIMO.1007A

U.S. PATENT DOCUMENTS

Examiner Initials	Cite No.	Document Number <i>Number - Kind Code (if known)</i> Example: 1,234,567 B1	Publication Date MM-DD-YYYY	Name of Patentee or Applicant	Pages, Columns, Lines Where Relevant Passages or Relevant Figures Appear
	204	8,721,541	05/13/2014	Al-Ali et al.	
	205	2014/0142401	05/22/2014	Al-Ali et al.	
	206	8,720,249	05/13/2014	Al-Ali	
	207	2014/0135588	05/15/2014	Al-Ali et al.	
	208	8,718,738	05/06/2014	Blank et al.	
	209	2014/0129702	05/08/2014	Lamego et al.	
	210	2014/0127137	05/08/2014	Bellott et al.	
	211	8,718,737	05/06/2014	Diab et al.	
	212	8,718,735	05/06/2014	Lamego et al.	
	213	2014/0121483	05/01/2014	Kiani	
	214	2014/0121482	05/01/2014	Merritt et al.	
	215	2014/0120564	05/01/2014	Workman et al.	
	216	8,715,206	05/06/2014	Telfort et al.	
	217	8,712,494	04/29/2014	MacNeish, III et al.	
	218	8,706,179	04/22/2014	Parker	
	219	8,702,627	04/22/2014	Telfort et al.	
	220	8,700,112	04/15/2014	Kiani	
	221	8,690,799	04/08/2014	Telfort et al.	
	222	2014/0114199	04/24/2014	Lamego et al.	
	223	2014/0100434	04/10/2014	Diab et al.	
	224	2014/0094667	04/03/2014	Schurman et al.	
	225	RE44,875	04/29/2014	Kiani et al.	
	226	RE44,823	04/01/2014	Parker	
	227	8,682,407	03/25/2014	Al-Ali	
	228	2014/0081175	03/20/2014	Telfort	
	229	8,676,286	03/18/2014	Weber et al.	
	230	8,670,814	03/11/2014	Diab et al.	
	231	2014/0081100	03/20/2014	Muhsin et al.	
	232	8,670,811	03/11/2014	O'Reilly	

Examiner Signature	Date Considered
<p>*Examiner: Initial if reference considered, whether or not citation is in conformance with MPEP 609. Draw line through citation if not in conformance and not considered. Include copy of this form with next communication to applicant.</p>	

T¹ - Place a check mark in this area when an English language Translation is attached.

PTO/SB/08 Equivalent

INFORMATION DISCLOSURE STATEMENT BY APPLICANT	Application No.	Unknown	
	Filing Date	Herewith	
	First Named Inventor	Ammar Al-Ali	
	Art Unit	Unknown	
<i>(Multiple sheets used when necessary)</i>		Examiner	Unknown
SHEET 9 OF 24		Attorney Docket No.	MASIMO.1007A

U.S. PATENT DOCUMENTS					
Examiner Initials	Cite No.	Document Number <i>Number - Kind Code (if known)</i> Example: 1,234,567 B1	Publication Date MM-DD-YYYY	Name of Patentee or Applicant	Pages, Columns, Lines Where Relevant Passages or Relevant Figures Appear
	233	8,667,967	03/11/2014	Al- Ali et al.	
	234	2014/0077956	03/20/2014	Sampath et al.	
	235	8,666,468	03/04/2014	Al-Ali	
	236	2014/0066783	03/06/2014	Kiani et al.	
	237	8,663,107	03/04/2014	Kiani	
	238	2014/0051953	02/20/2014	Lamego et al.	
	239	8,652,060	02/18/2014	Al-Ali	
	240	2014/0034353	02/06/2014	Al-Ali et al.	
	241	8,641,631	02/04/2014	Sierra et al.	
	242	8,634,889	01/21/2014	Al-Ali et al.	
	243	8,630,691	01/14/2014	Lamego et al.	
	244	2014/0012100	01/09/2014	Al-Ali et al.	
	245	8,626,255	01/07/2014	Al-Ali et al.	
	246	2013/0331660	12/12/2013	Al-Ali et al.	
	247	2013/0331670	12/12/2013	Kiani	
	248	8,606,342	12/10/2013	Diab	
	249	2013/0324808	12/05/2013	Al-Ali et al.	
	250	8,600,467	12/03/2013	Al-Ali et al.	
	251	8,588,880	11/19/2013	Abdul-Hafiz et al.	
	252	8,584,345	11/19/2013	Al-Ali et al.	
	253	8,581,732	11/12/2013	Al-Ali et al.	
	254	2013/0317370	11/28/2013	Dalvi et al.	
	255	2013/0296713	11/07/2013	Al-Ali et al.	
	256	2013/0296672	11/07/2013	O'Neil et al.	
	257	8,577,431	11/05/2013	Lamego et al.	
	258	8,571,619	10/29/2013	Al-Ali et al.	
	259	8,571,618	10/29/2013	Lamego et al.	
	260	8,571,617	10/29/2013	Reichgott et al.	
	261	8,570,503	10/29/2013	Vo et al.	

Examiner Signature	Date Considered
<p>*Examiner: Initial if reference considered, whether or not citation is in conformance with MPEP 609. Draw line through citation if not in conformance and not considered. Include copy of this form with next communication to applicant.</p>	

T¹ - Place a check mark in this area when an English language Translation is attached.

PTO/SB/08 Equivalent

INFORMATION DISCLOSURE STATEMENT BY APPLICANT	Application No.	Unknown	
	Filing Date	Herewith	
	First Named Inventor	Ammar Al-Ali	
	Art Unit	Unknown	
<i>(Multiple sheets used when necessary)</i>		Examiner	Unknown
SHEET 10 OF 24		Attorney Docket No.	MASIMO.1007A

U.S. PATENT DOCUMENTS

Examiner Initials	Cite No.	Document Number <i>Number - Kind Code (if known)</i> Example: 1,234,567 B1	Publication Date MM-DD-YYYY	Name of Patentee or Applicant	Pages, Columns, Lines Where Relevant Passages or Relevant Figures Appear
	262	8,570,167	10/29/2013	Al-Ali	
	263	D692,145	10/22/2013	Al-Ali et al.	
	264	2013/0274572	10/17/2013	Al-Ali et al.	
	265	8,560,034	10/15/2013	Diab et al.	
	266	8,560,032	10/15/2013	Al-Ali et al.	
	267	2013/0267804	10/10/2013	Al-Ali	
	268	2013/0262730	10/03/2013	Al-Ali et al.	
	269	8,548,550	10/01/2013	Al-Ali et al.	
	270	8,548,549	10/01/2013	Schurman et al.	
	271	8,548,548	10/01/2013	Al-Ali	
	272	8,547,209	10/01/2013	Kiani et al.	
	273	8,532,728	09/10/2013	Diab et al.	
	274	2013/0253334	09/26/2013	Al-Ali et al.	
	275	8,532,727	09/10/2013	Ali et al.	
	276	8,529,301	09/10/2013	Al-Ali et al.	
	277	2013/0243021	09/19/2013	Siskavich	
	278	8,523,781	09/03/2013	Al-Ali	
	279	8,515,509	08/20/2013	Bruinsma et al.	
	280	2013/0211214	08/15/2013	Olsen	
	281	8,509,867	08/13/2013	Workman et al.	
	282	8,504,128	08/06/2013	Blank et al.	
	283	8,498,684	0730//2013	Weber et al.	
	284	8,489,364	07/16/2013	Weber et al.	
	285	2013/0190581	07/25/2013	Al-Ali et al.	
	286	8,483,787	07/09/2013	Al-Ali et al.	
	287	8,473,020	06/25/2013	Kiani et al.	
	288	8,471,713	06/25/2013	Poeze et al.	
	289	8,466,286	06/18/2013	Bellot et al.	
	290	8,463,349	06/11/2013	Diab et al.	

Examiner Signature	Date Considered
<p>*Examiner: Initial if reference considered, whether or not citation is in conformance with MPEP 609. Draw line through citation if not in conformance and not considered. Include copy of this form with next communication to applicant.</p>	

T¹ - Place a check mark in this area when an English language Translation is attached.

PTO/SB/08 Equivalent

INFORMATION DISCLOSURE STATEMENT BY APPLICANT	Application No.	Unknown	
	Filing Date	Herewith	
	First Named Inventor	Ammar Al-Ali	
	Art Unit	Unknown	
<i>(Multiple sheets used when necessary)</i>		Examiner	Unknown
SHEET 11 OF 24		Attorney Docket No.	MASIMO.1007A

U.S. PATENT DOCUMENTS					
Examiner Initials	Cite No.	Document Number <i>Number - Kind Code (if known)</i> Example: 1,234,567 B1	Publication Date MM-DD-YYYY	Name of Patentee or Applicant	Pages, Columns, Lines Where Relevant Passages or Relevant Figures Appear
	291	8,457,707	06/04/2013	Kiani	
	292	8,457,703	06/04/2013	Al-Ali	
	293	8,455,290	06/04/2013	Siskavich	
	294	8,437,825	05/07/2013	Dalvi et al.	
	295	8,430,817	04/30/2013	Al-Ali et al.	
	296	8,428,967	04/23/2013	Olsen et al.	
	297	8,423,106	04/16/2013	Lamego et al.	
	298	2013/0096936	04/18/2013	Sampath et al.	
	299	8,418,524	04/16/2013	Al-Ali	
	300	2013/0096405	04/18/2013	Garfio	
	301	8,414,499	04/09/2013	Al-Ali et al.	
	302	8,405,608	03/26/2013	Al-Ali et al.	
	303	8,401,602	03/19/2013	Kiani	
	304	2013/0060147	03/07/2013	Welch et al.	
	305	8,399,822	03/19/2013	Al-Ali	
	306	8,388,353	03/05/2013	Kiani et la.	
	307	2013/0041591	02/14/2013	Lamego	
	308	8,385,996	02/26/2013	Smith et al.	
	309	2013/0046204	02/21/2013	Lamego et al.	
	310	8,385,995	02/26/2013	Al-ali et al.	
	311	8,374,665	02/12/2013	Lamego	
	312	8,364,226	01/29/2013	Diab et al.	
	313	8,364,223	01/29/2013	Al-Ali et al.	
	314	2013/0023775	01/24/2013	Lamego et al.	
	315	8,359,080	01/22/2013	Diab et al.	
	316	8,385,996	02/26/2013	Smith et al.	
	317	8,374,665	02/12/2013	Lamego	
	318	8,355,766	01/15/2013	MacNeish, III et al.	
	319	8,353,842	01/15/2013	Al-Ali et al.	

Examiner Signature	Date Considered
<p>*Examiner: Initial if reference considered, whether or not citation is in conformance with MPEP 609. Draw line through citation if not in conformance and not considered. Include copy of this form with next communication to applicant.</p>	

T¹ - Place a check mark in this area when an English language Translation is attached.

PTO/SB/08 Equivalent

INFORMATION DISCLOSURE STATEMENT BY APPLICANT	Application No.	Unknown	
	Filing Date	Herewith	
	First Named Inventor	Ammar Al-Ali	
	Art Unit	Unknown	
<i>(Multiple sheets used when necessary)</i>		Examiner	Unknown
SHEET 12 OF 24		Attorney Docket No.	MASIMO.1007A

U.S. PATENT DOCUMENTS

Examiner Initials	Cite No.	Document Number <i>Number - Kind Code (if known)</i> Example: 1,234,567 B1	Publication Date MM-DD-YYYY	Name of Patentee or Applicant	Pages, Columns, Lines Where Relevant Passages or Relevant Figures Appear
	320	2013/0006076	01/03/2013	McHale	
	321	8,346,330	01/01/2013	Lamego	
	322	2012/0330112	12/27/2012	Lamego et al.	
	323	8,337,403	12/25/2012	Al-Ali et al.	
	324	2012/0319816	12/20/2012	Al-Ali	
	325	RE43,860	12/11/2012	Parker	
	326	8,315,683	11/20/2012	Al-Ali et al.	
	327	8,310,336	11/13/2012	Muhsin et al.	
	328	2012/0296178	11/22/2012	Lamego et al.	
	329	2012/0283524	11/08/2012	Kiani et al.	
	330	8,306,596	11/06/2012	Schurman et al.	
	331	8,301,217	10/30/2012	Al-Ali et al.	
	332	8,274,360	09/25/2012	Sampath et al.	
	333	8,265,723	09/11/2012	McHale et al.	
	334	8,260,577	09/04/2012	Weber et al.	
	335	8,255,028	08/28/2012	Al-Ali et al.	
	336	8,255,027	08/28/2012	Al-Ali et al.	
	337	2012/0209084	08/16/2012	Olsen et al.	
	338	8,255,026	08/28/2012	Al-Ali	
	339	2012/0209082	08/16/2012	Al-Ali	
	340	8,244,325	08/14/2012	Al-Ali et al.	
	341	8,233,955	07/31/2012	Al-Ali et al.	
	342	8,229,533	07/24/2012	Diab et al.	
	343	8,228,181	07/24/2012	Al-Ali	
	344	8,224,411	07/17/2012	Al-Ali et al.	
	345	2012/0179006	07/12/2012	Jansen et al.	
	346	8,219,172	07/10/2012	Schurman et al.	
	347	2012/0165629	06/28/2012	Merritt et al.	
	348	8,204,566	06/19/2012	Schurman et al.	

Examiner Signature	Date Considered
<p>*Examiner: Initial if reference considered, whether or not citation is in conformance with MPEP 609. Draw line through citation if not in conformance and not considered. Include copy of this form with next communication to applicant.</p>	

T¹ - Place a check mark in this area when an English language Translation is attached.

PTO/SB/08 Equivalent

INFORMATION DISCLOSURE STATEMENT BY APPLICANT	Application No.	Unknown	
	Filing Date	Herewith	
	First Named Inventor	Ammar Al-Ali	
	Art Unit	Unknown	
<i>(Multiple sheets used when necessary)</i>		Examiner	Unknown
SHEET 13 OF 24		Attorney Docket No.	MASIMO.1007A

U.S. PATENT DOCUMENTS					
Examiner Initials	Cite No.	Document Number <i>Number - Kind Code (if known)</i> Example: 1,234,567 B1	Publication Date MM-DD-YYYY	Name of Patentee or Applicant	Pages, Columns, Lines Where Relevant Passages or Relevant Figures Appear
	349	8,203,704	06/19/2012	Merritt et al.	
	350	8,203,438	06/19/2012	Kiani et al.	
	351	8,190,227	05/29/2012	Diab et al.	
	352	8,190,223	05/29/2012	Al-Ali et al.	
	353	8,185,180	05/22/2012	Diab et al.	
	354	8,182,443	05/22/2012	Kiani	
	355	8,180,420	05/15/2012	Diab et al.	
	356	8,175,672	05/08/2012	Parker	
	357	2012/0088984	04/12/2012	Al-Ali et al.	
	358	8,150,487	04/03/2012	Diab et al.	
	359	2012/0059267	03/08/2012	Lamego et al.	
	360	8,145,287	03/27/2012	Diab et al.	
	361	8,130,105	03/06/2012	Al-Ali et al.	
	362	8,128,572	03/06/2012	Diab et al.	
	363	8,126,528	02/28/2012	Diab et al.	
	364	2012/0046557	02/23/2012	Kiani	
	365	8,118,620	02/21/2012	Al-Ali et al.	
	366	2012/0041316	02/16/2012	Al-Ali et al.	
	367	RE43,169	02/07/2012	Parker	
	368	2011/0301444	12/08/2011	Al-Ali	
	369	2011/0288383	11/24/2011	Diab	
	370	8,050,728	11/01/2011	Al-Ali et al.	
	371	8,048,040	11/01/2011	Kiani	
	372	8,046,042	10/25/2011	Diab et al.	
	373	8,046,041	10/25/2011	Diab et al.	
	374	8,046,040	10/25/2011	Ali et al.	
	375	8,036,728	10/11/2011	Diab et al.	
	376	8,036,727	10/11/2011	Schurman et al.	
	377	8,029,765	10/04/2011	Bellott et al.	

Examiner Signature	Date Considered
<p>*Examiner: Initial if reference considered, whether or not citation is in conformance with MPEP 609. Draw line through citation if not in conformance and not considered. Include copy of this form with next communication to applicant.</p>	

T¹ - Place a check mark in this area when an English language Translation is attached.

PTO/SB/08 Equivalent

INFORMATION DISCLOSURE STATEMENT BY APPLICANT	Application No.	Unknown	
	Filing Date	Herewith	
	First Named Inventor	Ammar Al-Ali	
	Art Unit	Unknown	
<i>(Multiple sheets used when necessary)</i>		Examiner	Unknown
SHEET 14 OF 24		Attorney Docket No.	MASIMO.1007A

U.S. PATENT DOCUMENTS

Examiner Initials	Cite No.	Document Number <i>Number - Kind Code (if known)</i> Example: 1,234,567 B1	Publication Date MM-DD-YYYY	Name of Patentee or Applicant	Pages, Columns, Lines Where Relevant Passages or Relevant Figures Appear
	378	8,028,701	10/04/2011	Al-Ali et al.	
	379	2011/0237969	09/29/2011	Eckerbom et al.	
	380	2011/0230733	09/22/2011	Al-Ali	
	381	2011/0213212	09/01/2011	Al-Ali	
	382	RE42,753	09/27/2011	Kiani-Azarbayjany et al.	
	383	8,019,400	09/13/2011	Diab et al.	
	384	2011/0208015	08/25/2011	Welch et al.	
	385	8,008,088	08/30/2011	Bellott et al.	
	386	8,000,761	08/16/2011	Al-Ali	
	387	7,991,446	08/02/2011	Al-Ali et al.	
	388	7,990,382	08/02/2011	Kiani	
	389	7,988,637	08/02/2011	Diab	
	390	7,976,472	07/12/2011	Kiani	
	391	7,962,190	06/14/2011	Diab et al.	
	392	7,962,188	06/14/2011	Kiani et al.	
	393	7,957,780	06/07/2011	Lamego et al.	
	394	7,951,086	05/31/2011	Flaherty et al.	
	395	2011/0125060	05/26/2011	Telfort et al.	
	396	7,941,199	05/10/2011	Kiani	
	397	7,937,130	05/03/2011	Diab et al.	
	398	2011/0105854	05/05/2011	Kiani et al.	
	399	7,937,129	05/03/2011	Mason et al.	
	400	7,937,128	05/03/2011	Al-Ali	
	401	2011/0082711	04/07/2011	Poeze et al.	
	402	7,919,713	04/05/2011	Al-Ali et al.	
	403	7,910,875	03/22/2011	Al-Ali	
	404	7,909,772	03/22/2011	Popov et al.	
	405	7,904,132	03/08/2011	Weber et al.	
	406	7,899,518	03/01/2011	Trepagnier et al.	

Examiner Signature	Date Considered
<p>*Examiner: Initial if reference considered, whether or not citation is in conformance with MPEP 609. Draw line through citation if not in conformance and not considered. Include copy of this form with next communication to applicant.</p>	

T¹ - Place a check mark in this area when an English language Translation is attached.

PTO/SB/08 Equivalent

INFORMATION DISCLOSURE STATEMENT BY APPLICANT	Application No.	Unknown	
	Filing Date	Herewith	
	First Named Inventor	Ammar Al-Ali	
	Art Unit	Unknown	
<i>(Multiple sheets used when necessary)</i>		Examiner	Unknown
SHEET 15 OF 24		Attorney Docket No.	MASIMO.1007A

U.S. PATENT DOCUMENTS					
Examiner Initials	Cite No.	Document Number <i>Number - Kind Code (if known)</i> Example: 1,234,567 B1	Publication Date MM-DD-YYYY	Name of Patentee or Applicant	Pages, Columns, Lines Where Relevant Passages or Relevant Figures Appear
	407	7,899,507	03/01/2011	Al-Ali et al.	
	408	7,894,868	02/22/2011	Al-Ali et al.	
	409	7,891,355	02/22/2011	Al-Ali et al.	
	410	7,880,626	02/01/2011	Al-Ali et al.	
	411	7,880,606	02/01/2011	Al-Ali	
	412	7,873,497	01/18/2011	Weber et al.	
	413	7,865,222	01/04/2011	Weber et al.	
	414	7,844,315	11/30/2010	Al-Ali	
	415	7,844,314	11/30/2010	Al-Ali	
	416	7,844,313	11/30/2010	Kiani et al.	
	417	RE41,912	11/02/2010	Parker	
	418	7,822,452	10/26/2010	Schurman et al.	
	419	7,801,581	09/21/2010	Diab	
	420	7,791,155	09/07/2010	Diab	
	421	D621,516	08/10/2010	Kiani et al.	
	422	7,764,982	07/27/2010	Dalke et al.	
	423	7,761,128	07/20/2010	Al-Ali et al.	
	424	7,761,127	07/20/2010	Al-Ali et al.	
	425	7,734,320	06/08/2010	Al-Ali	
	426	7,729,733	06/01/2010	Al-Ali et al.	
	427	RE41,317	05/04/2010	Parker	
	428	D614,305	04/20/2010	Al-Ali et al.	
	429	2010/0030040	02/04/2010	Poeze et al.	
	430	D609,193	02/02/2010	Al-Ali et al.	
	431	2010/0004518	01/07/2010	Vo et al.	
	432	7,647,083	01/12/2010	Al-Ali et al.	
	433	D606,659	12/22/2009	Kiani et al.	
	434	2009/0275844	11/05/2009	Al-Ali	
	435	7,618,375	11/17/2009	Flaherty	

Examiner Signature	Date Considered
<p>*Examiner: Initial if reference considered, whether or not citation is in conformance with MPEP 609. Draw line through citation if not in conformance and not considered. Include copy of this form with next communication to applicant.</p>	

T¹ - Place a check mark in this area when an English language Translation is attached.

PTO/SB/08 Equivalent

INFORMATION DISCLOSURE STATEMENT BY APPLICANT	Application No.	Unknown	
	Filing Date	Herewith	
	First Named Inventor	Ammar Al-Ali	
	Art Unit	Unknown	
<i>(Multiple sheets used when necessary)</i>		Examiner	Unknown
SHEET 16 OF 24		Attorney Docket No.	MASIMO.1007A

U.S. PATENT DOCUMENTS

Examiner Initials	Cite No.	Document Number <i>Number - Kind Code (if known)</i> Example: 1,234,567 B1	Publication Date MM-DD-YYYY	Name of Patentee or Applicant	Pages, Columns, Lines Where Relevant Passages or Relevant Figures Appear
	436	2009/0275813	11/05/2009	Davis	
	437	2009/0247984	10/01/2009	Lamego et al.	
	438	7,596,398	09/29/2009	Al-Ali et al.	
	439	7,563,110	07/21/2009	Al-Ali et al.	
	440	7,530,955	05/12/2009	Diab et al.	
	441	7,530,949	05/12/2009	Al Ali et al.	
	442	7,530,942	05/12/2009	Diab	
	443	7,526,328	04/28/2009	Diab et al.	
	444	7,510,849	03/31/2009	Schurman et al.	
	445	7,509,494	03/24/2009	Al-Ali	
	446	7,509,154	03/24/2009	Diab et al.	
	447	7,500,950	03/10/2009	Al-Ali et al.	
	448	D587,657	03/03/2009	Al-Ali et al.	
	449	7,499,835	03/03/2009	Weber et al.	
	450	7,499,741	03/03/2009	Diab et al.	
	451	7,496,393	02/24/2009	Diab et al.	
	452	7,496,391	02/24/2009	Diab et al.	
	453	7,489,958	02/10/2009	Diab et al.	
	454	7,483,730	01/27/2009	Diab et al.	
	455	7,483,729	01/27/2009	Al-Ali et al.	
	456	7,471,971	12/30/2008	Diab et al.	
	457	7,471,969	12/30/2008	Diab et al.	
	458	7,469,157	12/23/2008	Diab et al.	
	459	7,467,002	12/16/2008	Weber et al.	
	460	7,454,240	11/18/2008	Diab et al.	
	461	7,440,787	10/21/2008	Diab	
	462	7,438,683	10/21/2008	Al-Ali et al.	
	463	7,428,432	09/23/2008	Ali et al.	
	464	7,415,297	08/19/2008	Al-Ali et al.	

Examiner Signature	Date Considered
<p>*Examiner: Initial if reference considered, whether or not citation is in conformance with MPEP 609. Draw line through citation if not in conformance and not considered. Include copy of this form with next communication to applicant.</p>	

T¹ - Place a check mark in this area when an English language Translation is attached.

PTO/SB/08 Equivalent

INFORMATION DISCLOSURE STATEMENT BY APPLICANT	Application No.	Unknown	
	Filing Date	Herewith	
	First Named Inventor	Ammar Al-Ali	
	Art Unit	Unknown	
<i>(Multiple sheets used when necessary)</i>		Examiner	Unknown
SHEET 17 OF 24		Attorney Docket No.	MASIMO.1007A

U.S. PATENT DOCUMENTS

Examiner Initials	Cite No.	Document Number <i>Number - Kind Code (if known)</i> Example: 1,234,567 B1	Publication Date MM-DD-YYYY	Name of Patentee or Applicant	Pages, Columns, Lines Where Relevant Passages or Relevant Figures Appear
	465	7,383,070	06/03/2008	Diab et al.	
	466	7,377,899	05/27/2008	Weber et al.	
	467	7,377,794	05/27/2008	Al Ali et al.	
	468	7,376,453	05/20/2008	Diab et al.	
	469	7,373,194	05/13/2008	Weber et al.	
	470	7,373,193	05/13/2008	Al-Ali et al.	
	471	7,371,981	05/13/2008	Abdul-Hafiz	
	472	7,356,365	04/08/2008	Schurman	
	473	D566,282	04/08/2008	Al-Ali et al.	
	474	7,355,512	04/08/2008	Al-Ali	
	475	7,343,186	03/11/2008	Lamego et al.	
	476	7,341,559	03/11/2008	Schulz et al.	
	477	7,340,287	03/04/2008	Mason et al.	
	478	7,332,784	02/19/2008	Mills, et al.	
	479	2008/0030468	02/07/2008	Al-Ali et al.	
	480	7,328,053	02/05/2008	Diab et al.	
	481	2007/0282478	12/06/2007	Al-Ali et al.	
	482	7,295,866	11/13/2007	Al-Ali	
	483	7,292,883	11/06/2007	De Felice et al.	
	484	D554,263	10/30/2007	Al-Ali	
	485	7,289,835	10/30/2007	Mansfield et al.	
	486	7,280,858	10/09/2007	Al-Ali et al.	
	487	7,274,955	09/25/2007	Kiani et al.	
	488	7,272,425	09/18/2007	Al-Ali	
	489	7,254,434	08/07/2007	Schulz et al.	
	490	7,254,433	08/07/2007	Diab et al.	
	491	7,254,431	08/07/2007	Al-Ali	
	492	7,254,429	08/07/2007	Schurman et al.	
	493	7,245,953	07/17/2007	Parker	

Examiner Signature	Date Considered
<p>*Examiner: Initial if reference considered, whether or not citation is in conformance with MPEP 609. Draw line through citation if not in conformance and not considered. Include copy of this form with next communication to applicant.</p>	

T¹ - Place a check mark in this area when an English language Translation is attached.

PTO/SB/08 Equivalent

INFORMATION DISCLOSURE STATEMENT BY APPLICANT	Application No.	Unknown	
	Filing Date	Herewith	
	First Named Inventor	Ammar Al-Ali	
	Art Unit	Unknown	
<i>(Multiple sheets used when necessary)</i>		Examiner	Unknown
SHEET 18 OF 24		Attorney Docket No.	MASIMO.1007A

U.S. PATENT DOCUMENTS

Examiner Initials	Cite No.	Document Number <i>Number - Kind Code (if known)</i> Example: 1,234,567 B1	Publication Date MM-DD-YYYY	Name of Patentee or Applicant	Pages, Columns, Lines Where Relevant Passages or Relevant Figures Appear
	494	7,239,905	07/03/2007	Kiani-Azarbayjany et al.	
	495	RE39,672	06/05/2007	Shehada et al.	
	496	7,225,007	05/29/2007	Al-Ali	
	497	7,225,006	05/29/2007	Al-Ali et al.	
	498	7,221,971	05/22/2007	Diab	
	499	7,215,986	05/08/2007	Diab	
	500	7,215,984	05/08/2007	Diab	
	501	7,190,261	03/13/2007	Al-Ali	
	502	7,186,966	03/06/2007	Al-Ali	
	503	7,149,561	12/12/2006	Diab	
	504	7,142,901	11/28/2006	Kiani et al.	
	505	7,132,641	11/07/2006	Schulz et al.	
	506	7,096,054	08/22/2006	Abdul-Hafiz et al.	
	507	7,096,052	08/22/2006	Mason et al.	
	508	7,067,893	06/27/2006	Mills et al.	
	509	7,044,918	05/16/2006	Diab	
	510	7,041,060	05/09/2006	Flaherty et al	
	511	7,039,449	05/02/2006	Al-Ali	
	512	7,030,749	04/18/2006	Al-Ali	
	513	7,027,849	04/11/2006	Al-Ali	
	514	7,024,233	04/04/2006	Ali et al.	
	515	7,015,451	03/21/2006	Dalke et al.	
	516	7,003,339	02/21/2006	Diab et al.	
	517	7,003,338	02/21/2006	Weber et al.	
	518	6,999,904	02/14/2006	Weber et al.	
	519	6,996,427	02/07/2006	Ali et al.	
	520	6,993,371	01/31/2006	Kiani et al.	
	521	6,985,764	01/10/2006	Mason et al.	
	522	6,979,812	12/27/2005	Al-Ali	

Examiner Signature	Date Considered
<p>*Examiner: Initial if reference considered, whether or not citation is in conformance with MPEP 609. Draw line through citation if not in conformance and not considered. Include copy of this form with next communication to applicant.</p>	

T¹ - Place a check mark in this area when an English language Translation is attached.

PTO/SB/08 Equivalent

INFORMATION DISCLOSURE STATEMENT BY APPLICANT	Application No.	Unknown	
	Filing Date	Herewith	
	First Named Inventor	Ammar Al-Ali	
	Art Unit	Unknown	
<i>(Multiple sheets used when necessary)</i>		Examiner	Unknown
SHEET 19 OF 24		Attorney Docket No.	MASIMO.1007A

U.S. PATENT DOCUMENTS

Examiner Initials	Cite No.	Document Number <i>Number - Kind Code (if known)</i> Example: 1,234,567 B1	Publication Date MM-DD-YYYY	Name of Patentee or Applicant	Pages, Columns, Lines Where Relevant Passages or Relevant Figures Appear
	523	2005/0277819	12/15/2005	Kiani et al.	
	524	6,970,792	11/29/2005	Diab	
	525	6,961,598	11/01/2005	Diab	
	526	6,950,687	09/27/2005	Al-Ali	
	527	6,943,348	09/13/2005	Coffin IV	
	528	6,939,305	09/06/2005	Flaherty et al.	
	529	6,934,570	08/23/2005	Kiani et al.	
	530	6,931,268	08/16/2005	Kiani-Azarbayjany et al.	
	531	6,920,345	07/19/2005	Al-Ali et al.	
	532	6,898,452	05/24/2005	Al-Ali et al.	
	533	6,861,639	03/01/2005	Al-Ali	
	534	6,852,083	02/08/2005	Caro et al.	
	535	6,850,788	02/01/2005	Al-Ali	
	536	6,850,787	02/01/2005	Weber et al.	
	537	6,830,711	12/14/2004	Mills et al.	
	538	6,826,419	11/30/2004	Diab et al.	
	539	6,822,564	11/23/2004	Al-Ali	
	540	6,816,741	11/09/2004	Diab	
	541	6,813,511	11/02/2004	Diab et al.	
	542	6,792,300	09/14/2004	Diab et al.	
	543	6,771,994	08/03/2004	Kiani et al.	
	544	6,770,028	08/03/2004	Ali et al.	
	545	6,760,607	07/06/2004	Al-Ali	
	546	6,745,060	06/01/2004	Diab et al.	
	547	6,735,459	05/11/2004	Parker	
	548	6,728,560	04/27/2004	Kollias, et al.	
	549	6,725,075	04/20/2004	Al-Ali	
	550	6,721,585	04/13/2004	Parker	
	551	6,721,582	04/13/2004	Trepagnier, et al.	

Examiner Signature	Date Considered
<p>*Examiner: Initial if reference considered, whether or not citation is in conformance with MPEP 609. Draw line through citation if not in conformance and not considered. Include copy of this form with next communication to applicant.</p>	

T¹ - Place a check mark in this area when an English language Translation is attached.

PTO/SB/08 Equivalent

INFORMATION DISCLOSURE STATEMENT BY APPLICANT	Application No.	Unknown	
	Filing Date	Herewith	
	First Named Inventor	Ammar Al-Ali	
	Art Unit	Unknown	
<i>(Multiple sheets used when necessary)</i>		Examiner	Unknown
SHEET 20 OF 24		Attorney Docket No.	MASIMO.1007A

U.S. PATENT DOCUMENTS					
Examiner Initials	Cite No.	Document Number <i>Number - Kind Code (if known)</i> Example: 1,234,567 B1	Publication Date MM-DD-YYYY	Name of Patentee or Applicant	Pages, Columns, Lines Where Relevant Passages or Relevant Figures Appear
	552	RE38,492	04/06/2004	Diab et al.	
	553	6,714,804	03/30/2004	Al-Ali et al.	
	554	RE38,476	03/30/2004	Diab et al.	
	555	6,699,194	03/02/2004	Diab et al.	
	556	6,697,658	02/24/2004	Al-Ali	
	557	6,697,657	02/24/2004	Shehada, et al.	
	558	6,697,656	02/24/2004	Al-Ali	
	559	6,684,091	01/27/2004	Parker	
	560	6,684,090	01/27/2004	Ali et al.	
	561	6,678,543	01/13/2004	Diab et al.	
	562	6,671,531	12/30/2003	Al-Ali et al.	
	563	6,661,161	12/09/2003	Lanzo et al.	
	564	6,658,276	12/02/2003	Kiani et al.	
	565	6,654,624	11/25/2003	Diab et al.	
	566	6,650,917	11/18/2003	Diab et al.	
	567	6,643,530	11/04/2003	Diab et al.	
	568	6,640,116	10/28/2003	Diab	
	569	6,639,668	10/28/2003	Trepagnier, Pierre	
	570	6,632,181	10/14/2003	Flaherty et al.	
	571	6,606,511	08/12/2003	Ali et al.	
	572	6,597,933	07/22/2003	Kiani et al.	
	573	6,597,932	07/22/2003	Tian et al.	
	574	6,595,316	07/22/2003	Cybulski et al.	
	575	6,584,336	06/24/2003	Ali et al.	
	576	6,580,086	06/17/2003	Schulz et al.	
	577	6,542,764	04/01/2003	Al-Ali et al.	
	578	6,541,756	04/01/2003	Schulz et al.	
	579	6,526,300	02/25/2003	Kiani et al.	
	580	6,525,386	02/25/2003	Mills et al.	

Examiner Signature	Date Considered
<p>*Examiner: Initial if reference considered, whether or not citation is in conformance with MPEP 609. Draw line through citation if not in conformance and not considered. Include copy of this form with next communication to applicant.</p>	

T¹ - Place a check mark in this area when an English language Translation is attached.

PTO/SB/08 Equivalent

INFORMATION DISCLOSURE STATEMENT BY APPLICANT	Application No.	Unknown	
	Filing Date	Herewith	
	First Named Inventor	Ammar Al-Ali	
	Art Unit	Unknown	
<i>(Multiple sheets used when necessary)</i>		Examiner	Unknown
SHEET 21 OF 24		Attorney Docket No.	MASIMO.1007A

U.S. PATENT DOCUMENTS					
Examiner Initials	Cite No.	Document Number <i>Number - Kind Code (if known)</i> Example: 1,234,567 B1	Publication Date MM-DD-YYYY	Name of Patentee or Applicant	Pages, Columns, Lines Where Relevant Passages or Relevant Figures Appear
	581	6,519,487	02/11/2003	Parker	
	582	6,515,273	02/04/2003	Al-Ali	
	583	6,505,059	01/07/2003	Kollias, et al.	
	584	6,501,975	12/31/2002	Diab et al.	
	585	6,470,199	10/22/2002	Kopotic et al.	
	586	6,463,311	10/08/2002	Diab	
	587	6,430,525	08/06/2002	Weber et al.	
	588	6,430,437	08/06/2002	Marro	
	589	6,397,091	05/28/2002	Diab et al.	
	590	6,388,240	05/14/2002	Schulz et al.	
	591	6,377,829	04/23/2002	Al-Ali	
	592	6,371,921	04/16/2002	Caro et al.	
	593	6,368,283	04/09/2002	Xu, et al.	
	594	6,360,114	03/19/2002	Diab et al.	
	595	6,349,228	02/19/2002	Kiani et al.	
	596	6,343,224	01/29/2002	Parker	
	597	6,334,065	12/25/2001	Al-Ali et al.	
	598	6,325,761	12/04/2001	Jay	
	599	6,321,100	11/20/2001	Parker	
	600	6,317,627	11/13/2001	Ennen et al.	
	601	6,301,493	10/09/2001	Marro et al.	
	602	6,285,896	09/04/2001	Tobler et al.	
	603	6,280,213	08/28/2001	Tobler et al.	
	604	6,278,522	08/21/2001	Lepper, Jr. et al.	
	605	6,263,222	07/17/2001	Diab et al.	
	606	6,256,523	07/03/2001	Diab et al.	
	607	6,253,097	06/26/2001	Aronow et al.	
	608	6,241,683	06/05/2001	Macklem, et al.	
	609	6,236,872	05/22/2001	Diab et al.	

Examiner Signature	Date Considered
<p>*Examiner: Initial if reference considered, whether or not citation is in conformance with MPEP 609. Draw line through citation if not in conformance and not considered. Include copy of this form with next communication to applicant.</p>	

T¹ - Place a check mark in this area when an English language Translation is attached.

PTO/SB/08 Equivalent

INFORMATION DISCLOSURE STATEMENT BY APPLICANT	Application No.	Unknown	
	Filing Date	Herewith	
	First Named Inventor	Ammar Al-Ali	
	Art Unit	Unknown	
<i>(Multiple sheets used when necessary)</i>		Examiner	Unknown
SHEET 22 OF 24		Attorney Docket No.	MASIMO.1007A

U.S. PATENT DOCUMENTS					
Examiner Initials	Cite No.	Document Number <i>Number - Kind Code (if known)</i> Example: 1,234,567 B1	Publication Date MM-DD-YYYY	Name of Patentee or Applicant	Pages, Columns, Lines Where Relevant Passages or Relevant Figures Appear
	610	6,232,609	05/15/2001	Snyder, et al.	
	611	6,229,856	05/08/2001	Diab et al.	
	612	6,206,830	03/27/2001	Diab et al.	
	613	6,184,521	02/06/2001	Coffin, IV et al.	
	614	6,165,005	12/26/2000	Mills et al.	
	615	6,157,850	12/05/2000	Diab et al.	
	616	6,152,754	11/28/2000	Gerhardt et al.	
	617	6,151,516	11/21/2000	Kiani-Azarbayjany et al.	
	618	6,144,868	11/07/2000	Parker	
	619	6,129,675	10/10/2000	Jay	
	620	6,128,521	10/03/2000	Marro et al.	
	621	6,124,597	09/26/2000	Shehada	
	622	6,110,522	08/29/2000	Lepper, Jr. et al.	
	623	6,088,607	07/11/2000	Diab et al.	
	624	6,081,735	06/27/2000	Diab et al.	
	625	6,067,462	05/23/2000	Diab et al.	
	626	6,045,509	04/04/2000	Caro et al.	
	627	6,036,642	03/14/2000	Diab et al.	
	628	6,027,452	02/22/2000	Flaherty et al.	
	629	6,011,986	01/04/2000	Diab et al.	
	630	6,002,952	12/14/1999	Diab et al.	
	631	5,997,343	12/07/1999	Mills et al.	
	632	5,995,855	11/30/1999	Kiani et al.	
	633	5,940,182	08/17/1999	Lepper, Jr. et al.	
	634	5,934,925	08/10/1999	Tobler et al.	
	635	5,919,134	07/06/1999	Diab	
	636	5,904,654	05/18/1999	Wohlmann et al.	
	637	5,890,929	04/06/1999	Mills et al.	
	638	5,860,919	01/19/1999	Kiani-Azarbayjany et al.	

Examiner Signature	Date Considered
<p>*Examiner: Initial if reference considered, whether or not citation is in conformance with MPEP 609. Draw line through citation if not in conformance and not considered. Include copy of this form with next communication to applicant.</p>	

T¹ - Place a check mark in this area when an English language Translation is attached.

PTO/SB/08 Equivalent

INFORMATION DISCLOSURE STATEMENT BY APPLICANT	Application No.	Unknown	
	Filing Date	Herewith	
	First Named Inventor	Ammar Al-Ali	
	Art Unit	Unknown	
<i>(Multiple sheets used when necessary)</i>		Examiner	Unknown
SHEET 23 OF 24		Attorney Docket No.	MASIMO.1007A

U.S. PATENT DOCUMENTS					
Examiner Initials	Cite No.	Document Number <i>Number - Kind Code (if known)</i> Example: 1,234,567 B1	Publication Date MM-DD-YYYY	Name of Patentee or Applicant	Pages, Columns, Lines Where Relevant Passages or Relevant Figures Appear
	639	5,833,618	11/10/1998	Caro et al.	
	640	5,830,131	11/03/1998	Caro et al.	
	641	5,823,950	10/20/1998	Diab et al.	
	642	5,810,734	09/22/1998	Caro et al.	
	643	5,791,347	08/11/1998	Flaherty et al.	
	644	5,785,659	07/28/1998	Caro et al.	
	645	5,782,757	07/21/1998	Diab et al.	
	646	5,769,785	06/23/1998	Diab et al.	
	647	5,760,910	06/02/1998	Lepper, Jr. et al.	
	648	5,758,644	06/02/1998	Diab et al.	
	649	5,743,262	04/28/1998	Lepper, Jr. et al.	
	650	D393,830	04/28/1998	Tobler et al.	
	651	5,685,299	11/11/1997	Diab et al.	
	652	5,645,440	07/08/1997	Tobler et al.	
	653	5,638,818	06/17/1997	Diab et al.	
	654	5,638,816	06/17/1997	Kiani-Azarbayjany et al.	
	655	5,632,272	05/27/1997	Diab et al.	
	656	5,602,924	02/11/1997	Durand et al.	
	657	5,590,649	01/07/1997	Caro et al.	
	658	5,562,002	10/08/1996	Lalin	
	659	5,561,275	10/01/1996	Savage, et al.	
	660	5,533,511	07/09/1996	Kaspari et al.	
	661	5,534,851	07/09/1996	Russek	
	662	5,494,043	02/27/1996	O'Sullivan et al.	
	663	5,490,505	02/13/1996	Diab et al.	
	664	5,482,036	01/09/1996	Diab et al.	
	665	5,479,934	01/02/1996	Imran	
	666	5,456,252	10/10/1995	Vari, et al.	
	667	D363,120	10/10/1995	Savage, et al.	

Examiner Signature	Date Considered
<p>*Examiner: Initial if reference considered, whether or not citation is in conformance with MPEP 609. Draw line through citation if not in conformance and not considered. Include copy of this form with next communication to applicant.</p>	

T¹ - Place a check mark in this area when an English language Translation is attached.

INFORMATION DISCLOSURE STATEMENT BY APPLICANT	Application No.	Unknown	
	Filing Date	Herewith	
	First Named Inventor	Ammar Al-Ali	
	Art Unit	Unknown	
<i>(Multiple sheets used when necessary)</i>		Examiner	Unknown
SHEET 24 OF 24		Attorney Docket No.	MASIMO.1007A

U.S. PATENT DOCUMENTS					
Examiner Initials	Cite No.	Document Number <i>Number - Kind Code (if known)</i> Example: 1,234,567 B1	Publication Date MM-DD-YYYY	Name of Patentee or Applicant	Pages, Columns, Lines Where Relevant Passages or Relevant Figures Appear
	668	5,452,717	09/26/1995	Branigan et al.	
	669	D362,063	09/05/1995	Savage, et al.	
	670	D361,840	08/29/1995	Savage, et al.	
	671	5,431,170	07/11/1995	Mathews	
	672	D359,546	06/20/1995	Savage, et al.	
	673	5,377,676	01/03/1995	Vari, et al.	
	674	D353,196	12/06/1994	Savage, et al.	
	675	D353,195	12/06/1994	Savage, et al.	
	676	5,341,805	08/30/1994	Stavridi, et al.	
	677	5,337,744	08/16/1994	Branigan	
	678	5,319,355	06/07/1994	Russek	
	679	5,163,438	11/17/1992	Gordon et al.	
	680	5,069,213	12/03/1991	Polczynski	
	681	5,041,187	08/20/1991	Hink et al.	
	682	4,964,408	10/23/1990	Hink et al.	
	683	4,960,128	10/02/1990	Gordon et al.	

FOREIGN PATENT DOCUMENTS						
Examiner Initials	Cite No.	Foreign Patent Document <i>Country Code-Number-Kind Code</i> Example: JP 1234567 A1	Publication Date MM-DD-YYYY	Name of Patentee or Applicant	Pages, Columns, Lines Where Relevant Passages or Relevant Figures Appear	T ¹

NON PATENT LITERATURE DOCUMENTS			
Examiner Initials	Cite No.	Include name of the author (in CAPITAL LETTERS), title of the article (when appropriate), title of the item (book, magazine, journal, serial, symposium, catalog, etc.), date, page(s), volume-issue number(s), publisher, city and/or country where published.	T ¹

23636987

Examiner Signature	Date Considered
<p>*Examiner: Initial if reference considered, whether or not citation is in conformance with MPEP 609. Draw line through citation if not in conformance and not considered. Include copy of this form with next communication to applicant.</p>	

T¹ - Place a check mark in this area when an English language Translation is attached.

MASIMO.1007A

PATENT

ADVANCED PULSE OXIMETRY SENSOR

INCORPORATION BY REFERENCE TO ANY PRIORITY APPLICATIONS

[0001] This present application claims priority benefit under 35 U.S.C. § 119(e) from U.S. Provisional Application No. 62/188,430, filed July 2, 2015, entitled “Advanced Pulse Oximetry Sensor,” which is incorporated by reference herein. Any and all applications for which a foreign or domestic priority claim is identified in the Application Data Sheet as filed with the present application are hereby incorporated by reference under 37 CFR 1.57.

FIELD OF THE DISCLOSURE

[0002] The present disclosure relates to the field of non-invasive optical-based physiological monitoring sensors, and more particularly to systems, devices and methods for improving the non-invasive measurement accuracy of oxygen saturation, among other physiological parameters.

BACKGROUND

[0003] Spectroscopy is a common technique for measuring the concentration of organic and some inorganic constituents of a solution. The theoretical basis of this technique is the Beer-Lambert law, which states that the concentration c_i of an absorbent in solution can be determined by the intensity of light transmitted through the solution, knowing the pathlength d_λ , the intensity of the incident light $I_{o,\lambda}$, and the extinction coefficient $\varepsilon_{i,\lambda}$ at a particular wavelength λ .

[0004] In generalized form, the Beer-Lambert law is expressed as:

$$I_\lambda = I_{o,\lambda} e^{-d_\lambda \cdot \mu_{a,\lambda}} \quad (1)$$

$$\mu_{a,\lambda} = \sum_{i=1}^n \varepsilon_{i,\lambda} \cdot c_i \quad (2)$$

where $\mu_{a,\lambda}$ is the bulk absorption coefficient and represents the probability of absorption per unit length. The minimum number of discrete wavelengths that are

required to solve equations 1 and 2 is the number of significant absorbers that are present in the solution.

[0005] A practical application of this technique is pulse oximetry, which utilizes a noninvasive sensor to measure oxygen saturation and pulse rate, among other physiological parameters. Pulse oximetry relies on a sensor attached externally to the patient to output signals indicative of various physiological parameters, such as a patient's blood constituents and/or analytes, including for example a percent value for arterial oxygen saturation, among other physiological parameters. The sensor has an emitter that transmits optical radiation of one or more wavelengths into a tissue site and a detector that responds to the intensity of the optical radiation after absorption by pulsatile arterial blood flowing within the tissue site. Based upon this response, a processor determines the relative concentrations of oxygenated hemoglobin (HbO₂) and deoxygenated hemoglobin (Hb) in the blood so as to derive oxygen saturation, which can provide early detection of potentially hazardous decreases in a patient's oxygen supply.

[0006] A pulse oximetry system generally includes a patient monitor, a communications medium such as a cable, and/or a physiological sensor having one or more light emitters and a detector, such as one or more light-emitting diodes (LEDs) and a photodetector. The sensor is attached to a tissue site, such as a finger, toe, earlobe, nose, hand, foot, or other site having pulsatile blood flow which can be penetrated by light from the one or more emitters. The detector is responsive to the emitted light after attenuation or reflection by pulsatile blood flowing in the tissue site. The detector outputs a detector signal to the monitor over the communication medium. The monitor processes the signal to provide a numerical readout of physiological parameters such as oxygen saturation (SpO₂) and/or pulse rate. A pulse oximetry sensor is described in U.S. Patent No. 6,088,607 entitled *Low Noise Optical Probe*; pulse oximetry signal processing is described in U.S. Patent Nos. 6,650,917 and 6,699,194 entitled *Signal Processing Apparatus* and *Signal Processing Apparatus and Method*, respectively; a pulse oximeter monitor is described in U.S. Patent No. 6,584,336 entitled *Universal/Upgrading Pulse*

Oximeter, all of which are assigned to Masimo Corporation, Irvine, CA, and each is incorporated by reference herein in its entirety.

[0007] There are many sources of measurement error introduced to pulse oximetry systems. Some such sources of error include the pulse oximetry system's electronic components, including emitters and detectors, as well as chemical and structural physiological differences between patients. Another source of measurement error is the effect of multiple scattering of photons as the photons pass through the patient's tissue (arterial blood) and arrive at the sensor's light detector.

SUMMARY

[0008] This disclosure describes embodiments of non-invasive methods, devices, and systems for measuring blood constituents, analytes, and/or substances such as, by way of non-limiting example, oxygen, carboxyhemoglobin, methemoglobin, total hemoglobin, glucose, proteins, lipids, a percentage thereof (*e.g.*, saturation), pulse rate, perfusion index, oxygen content, total hemoglobin, Oxygen Reserve Index™ (ORI™) or for measuring many other physiologically relevant patient characteristics. These characteristics can relate to, for example, pulse rate, hydration, trending information and analysis, and the like.

[0009] In an embodiment, an optical physiological measurement system includes an emitter configured to emit light of one or more wavelengths. The system also includes a diffuser configured to receive the emitted light, to spread the received light, and to emit the spread light over a larger tissue area than would otherwise be penetrated by the emitter directly emitting light at a tissue measurement site. The tissue measurement site can include, such as, for example, a finger, a wrist, or the like. The system further includes a concentrator configured to receive the spread light after it has been attenuated by or reflected from the tissue measurement site. The concentrator is also configured to collect and concentrate the received light and to emit the concentrated light to a detector. The detector is configured to detect the concentrated light and to transmit a signal indicative of the detected light. The system also includes a processor configured to receive the

transmitted signal indicative of the detected light and to determine, based on an amount of absorption, an analyte of interest, such as, for example, arterial oxygen saturation or other parameter, in the tissue measurement site.

[0010] In certain embodiments of the present disclosure, the diffuser comprises glass, ground glass, glass beads, opal glass, or a microlens-based, band-limited, engineered diffuser that can deliver efficient and uniform illumination. In some embodiments the diffuser is further configured to define a surface area shape by which the emitted spread light is distributed onto a surface of the tissue measurement site. The defined surface area shape can include, by way of non-limiting example, a shape that is substantially rectangular, square, circular, oval, or annular, among others.

[0011] According to some embodiments, the optical physiological measurement system includes an optical filter having a light-absorbing surface that faces the tissue measurement site. The optical filter also has an opening that is configured to allow the spread light, after being attenuated by the tissue measurement site, to be received by the concentrator. In an embodiment, the opening has dimensions, wherein the dimensions of the opening are similar to the defined surface area shape by which the emitted spread light is distributed onto the surface of the tissue measurement site. In an embodiment, the opening has dimensions that are larger than the defined surface area shape by which the emitted spread light is distributed onto the surface of the tissue measurement site. In other embodiments, the dimensions of the opening in the optical filter are not the same as the diffuser opening, but the dimensions are larger than the detector package.

[0012] In other embodiments of the present disclosure, the concentrator comprises glass, ground glass, glass beads, opal glass, or a compound parabolic concentrator. In some embodiments the concentrator comprises a cylindrical structure having a truncated circular conical structure on top. The truncated section is adjacent the detector. The light concentrator is structured to receive the emitted optical radiation, after reflection by the tissue measurement site, and to direct the reflected light to the detector.

[0013] In accordance with certain embodiments of the present disclosure, the processor is configured to determine an average level of the light detected by the detector. The average level of light is used to determine a physiological parameter in the tissue measurement site.

[0014] According to another embodiment, a method to determine a constituent or analyte in a patient's blood is disclosed. The method includes emitting, from an emitter, light of at least one wavelength; spreading, with a diffuser, the emitted light and emitting the spread light from the diffuser to a tissue measurement site; receiving, by a concentrator, the spread light after the spread light has been attenuated by the tissue measurement site; concentrating, by the concentrator, the received light and emitting the concentrated light from the concentrator to a detector; detecting, with the detector, the emitted concentrated light; transmitting, from the detector, a signal responsive to the detected light; receiving, by a processor, the transmitted signal responsive to the detected light; and processing, by the processor, the received signal responsive to the detected light to determine a physiological parameter.

[0015] In some embodiments, the method to determine a constituent or analyte in a patient's blood includes filtering, with a light-absorbing detector filter, scattered portions of the emitted spread light. According to an embodiment, the light-absorbing detector filter is substantially rectangular in shape and has outer dimensions in the range of approximately 1-5 cm in width and approximately 2-8 cm in length, and has an opening through which emitted light may pass, the opening having dimensions in the range of approximately 0.25-3 cm in width and approximately 1-7 cm in length. In another embodiment, the light-absorbing detector filter is substantially square in shape and has outer dimensions in the range of approximately 0.25-10 cm², and has an opening through which emitted light may pass, the opening having dimensions in the range of approximately 0.1-8cm². In yet another embodiment, the light-absorbing detector filter is substantially rectangular in shape and has outer dimensions of approximately 3 cm in width and approximately 6 cm in length, and has an opening through which emitted light may pass, the

opening having dimensions of approximately 1.5 cm in width and approximately 4 cm in length.

[0016] In still other embodiments of the method to determine a constituent or analyte in a patient's blood, spreading, with a diffuser, the emitted light and emitting the spread light from the diffuser to a tissue measurement site is performed by at least one of a glass diffuser, a ground glass diffuser, a glass bead diffuser, an opal glass diffuser, and an engineered diffuser. In some embodiments the emitted spread light is emitted with a substantially uniform intensity profile. And in some embodiments, emitting the spread light from the diffuser to the tissue measurement site includes spreading the emitted light so as to define a surface area shape by which the emitted spread light is distributed onto a surface of the tissue measurement site.

[0017] According to yet another embodiment, a pulse oximeter is disclosed. The pulse oximeter includes an emitter configured to emit light at one or more wavelengths. The pulse oximeter also includes a diffuser configured to receive the emitted light, to spread the received light, and to emit the spread light directed at a tissue measurement sight. The pulse oximeter also includes a detector configured to detect the emitted spread light after being attenuated by or reflected from the tissue measurement site and to transmit a signal indicative of the detected light. The pulse oximeter also includes a processor configured to receive the transmitted signal and to process the received signal to determine an average absorbance of a blood constituent or analyte in the tissue measurement site over a larger measurement site area than can be performed with a point light source or point detector. In some embodiments, the diffuser is further configured to define a surface area shape by which the emitted spread light is distributed onto a surface of the tissue measurement site, and the detector is further configured to have a detection area corresponding to the defined surface area shape by which the emitted spread light is distributed onto the surface of the tissue measurement site. According to some embodiments, the detector comprises an array of detectors configured to cover the detection area. In still other embodiments, the processor is further configured to determine an average of the detected light.

[0018] For purposes of summarizing, certain aspects, advantages and novel features of the disclosure have been described herein. It is to be understood that not necessarily all such advantages can be achieved in accordance with any particular embodiment of the systems, devices and/or methods disclosed herein. Thus, the subject matter of the disclosure herein can be embodied or carried out in a manner that achieves or optimizes one advantage or group of advantages as taught herein without necessarily achieving other advantages as can be taught or suggested herein.

BRIEF DESCRIPTION OF THE DRAWINGS

[0019] Throughout the drawings, reference numbers can be re-used to indicate correspondence between referenced elements. The drawings are provided to illustrate embodiments of the disclosure described herein and not to limit the scope thereof.

[0020] FIG. 1 illustrates a conventional approach to 2D pulse oximetry in which the emitter is configured to emit optical radiation as a point optical source.

[0021] FIG. 2 illustrates the disclosed 3D approach to pulse oximetry in which the emitted light irradiates a substantially larger volume of tissue as compared to the point source approach described with respect to FIG. 2A.

[0022] FIG. 3 illustrates schematically a side view of a 3D pulse oximetry sensor according to an embodiment of the present disclosure.

[0023] FIG. 4A is a top view of a portion of a 3D pulse oximetry sensor according to an embodiment of the present disclosure.

[0024] FIG. 4B illustrates the top view of a portion of the 3D pulse oximetry sensor shown in FIG. 4A, with the addition of a tissue measurement site in operational position.

[0025] FIG. 5 illustrates a top view of a 3D pulse oximetry sensor according to an embodiment of the present disclosure.

[0026] FIG. 6 illustrates a conventional 2D approach to reflective pulse oximetry in which the emitter is configured to emit optical radiation as a point optical source.

[0027] FIG. 7A is a simplified schematic side view illustration of a reflective 3D pulse oximetry sensor according to an embodiment of the present disclosure.

[0028] FIG. 7B is a simplified schematic top view illustration of the 3D reflective pulse oximetry sensor of FIG. 7A.

[0029] FIG. 8 illustrates a block diagram of an example pulse oximetry system capable of noninvasively measuring one or more blood analytes in a monitored patient, according to an embodiment of the disclosure.

DETAILED DESCRIPTION

[0030] FIG. 1 illustrates schematically a conventional pulse oximetry sensor having a two-dimensional (2D) approach to pulse oximetry. As illustrated, the emitter 104 is configured to emit optical radiation as a point optical source, *i.e.*, an optical radiation source that has negligible dimensions such that it may be considered as a point. This approach is referred to herein as “two-dimensional” pulse oximetry because it applies a two-dimensional analytical model to the three-dimensional space of the tissue measurement site 102 of the patient. Point optical sources feature a defined, freely selectable, and homogeneous light beam area. Light beams emitted from LED point sources often exhibit a strong focus which can produce a usually sharply-defined and evenly-lit illuminated spot often with high intensity dynamics. Illustratively, when looking at the surface of the tissue measurement site 102 (or “sample tissue”), which in this example is a finger, a small point-like surface area of tissue 204 is irradiated by a point optical source. In some embodiments, the irradiated circular area of the point optical source is in the range between 8 and 150 microns. Illustratively, the emitted point optical source of light enters the tissue measurement site 102 as a point of light. As the light penetrates the depth of the tissue 102, it does so as a line or vector, representing a two-dimensional construct within a three-dimensional structure, namely the patient’s tissue 102.

[0031] Use of a point optical source is believed to reduce variability in light pathlength which would lead to more accurate oximetry measurements. However, in practice, photons do not travel in straight paths. Instead, the light particles scatter,

bouncing around between various irregular objects (such as, for example, red blood cells) in the patient's blood. Accordingly, photon pathlengths vary depending on, among other things, their particular journeys through and around the tissue at the measurement site 102. This phenomenon is referred to as "multiple scattering." In a study, the effects of multiple scattering were examined by comparing the results of photon diffusion analysis with those obtained using an analysis based on the Beer-Lambert law, which neglects multiple scattering in the determination of light pathlength. The study found that that the difference between the average lengths of the paths traveled by red and infrared photons makes the oximeter's calibration curve (based on measurements obtained from normal subjects) sensitive to the total attenuation coefficients of the tissue in the two wavelength bands used for pulse oximetry, as well as to absorption by the pulsating arterial blood.

[0032] FIG. 2 illustrates schematically the disclosed systems, devices, and methods to implement three-dimensional (3D) pulse oximetry in which the emitted light irradiates a larger volume of tissue at the measurement site 102 as compared to the 2D point optical source approach described with respect to FIG. 1. In an embodiment, again looking at the surface of the tissue measurement site 102, the irradiated surface area 206 of the measurement site 102 is substantially rectangular in shape with dimensions in the range of approximately 0.25-3 cm in width and approximately 1-6 cm in length. In another embodiment, the irradiated surface area 206 of the measurement site 102 is substantially rectangular in shape and has dimensions of approximately 1.5 cm in width and approximately 2 cm in length. In another embodiment, the irradiated surface area 206 of the measurement site 102 is substantially rectangular in shape and has dimensions of approximately 0.5 cm in width and approximately 1 cm in length. In another embodiment, the irradiated surface area 206 of the measurement site 102 is substantially rectangular in shape has dimensions of approximately 1 cm in width and approximately 1.5 cm in length. In yet another embodiment, the irradiated surface area 206 of the measurement site 102 is substantially square in shape and has dimensions in a range of approximately 0.25-9 cm². In certain embodiments, the irradiated surface area 206 of the measurement site 102 is within a range of approximately 0.5-2 cm in width, and

approximately 1-4 cm in length. Of course a skilled artisan will appreciate that many other shapes and dimensions of irradiated surface area 206 can be used. Advantageously, by irradiating the tissue measurement site 102 with a surface area 206, the presently disclosed systems, devices, and methods apply a three-dimensional analytical model to the three-dimensional structure being measured, namely, the patient's sample tissue 102.

[0033] According to the Beer-Lambert law, the amount of light absorbed by a substance is proportional to the concentration of the light-absorbing substance in the irradiated solution (*i.e.*, arterial blood). Advantageously, by irradiating a larger volume of tissue 102, a larger sample size of light attenuated (or reflected) by the tissue 102 is measured. The larger, 3D sample provides a data set that is more representative of the complete interaction of the emitted light as it passes through the patient's blood as compared to the 2D point source approach described above with respect to FIG. 1. By taking an average of the detected light, as detected over a surface area substantially larger than a single point, the disclosed pulse oximetry systems, devices, and methods will yield a more accurate measurement of the emitted light absorbed by the tissue, which will lead to a more accurate oxygen saturation measurement.

[0034] FIG. 3 illustrates schematically a side view of a pulse oximetry 3D sensor 300 according to an embodiment of the present disclosure. In the illustrated embodiment, the 3D sensor 300 irradiates the tissue measurement site 102 and detects the emitted light, after being attenuated by the tissue measurement site 102. In other embodiments, for example, as describe below with respect to FIGS. 7A and 7B, the 3D sensor 300 can be arranged to detect light that is reflected by the tissue measurement site 102. The 3D sensor 300 includes an emitter 302, a light diffuser 304, a light-absorbing detector filter 306, a light concentrator 308, and a detector 310. In some optional embodiments, the 3D sensor 300 further includes a reflector 305. The reflector 305 can be a metallic reflector or other type of reflector. Reflector 305 can be a coating, film, layer or other type of reflector. The reflector 305 can serve as a reflector to prevent emitted light from emitting out of a top portion of the light diffuser 304 such that light from the emitter 302 is directed in the

tissue rather than escaping out of a side or top of the light diffuser 304. Additionally, the reflector 305 can prevent ambient light from entering the diffuser 304 which might ultimately cause errors within the detected light. The reflector 305 also prevent light piping that might occur if light from the detector 302 is able to escape from the light diffuser 304 and be piped around a sensor securement mechanism to detector 310 without passing through the patient's tissue 102.

The emitter 302 can serve as the source of optical radiation transmitted towards the tissue measurement site 102. The emitter 302 can include one or more sources of optical radiation, such as LEDs, laser diodes, incandescent bulbs with appropriate frequency-selective filters, combinations of the same, or the like. In an embodiment, the emitter 302 includes sets of optical sources that are capable of emitting visible and near-infrared optical radiation. In some embodiments, the emitter 302 transmits optical radiation of red and infrared wavelengths, at approximately 650 nm and approximately 940 nm, respectively. In some embodiments, the emitter 302 includes a single source optical radiation.

[0035] The light diffuser 304 receives the optical radiation emitted from the emitter 302 and spreads the optical radiation over an area, such as the area 206 depicted in FIG. 2. In some embodiments, the light diffuser 304 is a beam shaper that can homogenize the input light beam from the emitter 302, shape the output intensity profile of the received light, and define the way (*e.g.*, the shape or pattern) the emitted light is distributed to the tissue measurement site 102. Examples of materials that can be used to realize the light diffuser 304 include, without limitation, a white surface, glass, ground glass, glass beads, polytetrafluoroethylene (also known as Teflon®, opal glass, and greyed glass, to name a few. Additionally, engineered diffusers can be used to realize the diffuser 304 by providing customized light shaping with respect to intensity and distribution. Such diffusers can, for example, deliver substantially uniform illumination over a specified target area (such as, for example, irradiated surface area 206) in an energy-efficient manner. Examples of engineered diffusers can include molded plastics with specific shapes, patterns or textures designed to diffuse the emitter light across the entirety of the patient's tissue surface.

[0036] Advantageously, the diffuser 304 can receive emitted light in the form of a point optical source and spread the light to fit a desired surface area on a plane defined by the surface of the tissue measurement site 102. In an embodiment, the diffuser 304 is made of ground glass which spreads the emitted light with a Gaussian intensity profile. In another embodiment the diffuser 304 includes glass beads. In some embodiments, the diffuser 304 is constructed so as to diffuse the emitted light in a Lambertian pattern. A Lambertian pattern is one in which the radiation intensity is substantially constant throughout the area of dispersion. One such diffuser 304 is made from opal glass. Opal glass is similar to ground glass, but has one surface coated with a milky white coating to diffuse light evenly. In an embodiment, the diffuser 304 is capable of distributing the emitted light on the surface of a plane (*e.g.*, the surface of the tissue measurement site 102) in a predefined geometry (*e.g.*, a rectangle, square, or circle), and with a substantially uniform intensity profile and energy distribution. In some embodiments, the efficiency, or the amount of light transmitted by the diffuser 304, is greater than 70% of the light emitted by the emitter 302. In some embodiments, the efficiency is greater than 90% of the emitted light. Other optical elements known in the art may be used for the diffuser 304.

[0037] In an embodiment, the diffuser 304 has a substantially rectangular shape having dimensions within a range of approximately 0.5-2 cm in width and approximately 1-4 centimeters in length. In another embodiment, the substantially rectangular shape of the diffuser 304 has dimensions of approximately 0.5 cm in width and approximately 1 cm in length. In another embodiment, the diffuser's 304 substantially rectangular shape has dimensions of approximately 1 cm in width and approximately 1.5 cm in length. In yet another embodiment, the diffuser 304 has a substantially square shape with dimensions in the range of approximately 0.25-10 cm².

[0038] The light-absorbing detector filter 306, which is also depicted in FIG. 4A in a top view, is a planar surface having an opening 402 through which the emitted light may pass after being attenuated by the tissue measurement site 102. In the depicted embodiment, the opening 402 is rectangular-shaped, with

dimensions substantially similar to the irradiated surface area 206. According to an embodiment, the light-absorbing detector filter is substantially rectangular in shape and has outer dimensions of 4 cm in width and 8 cm in length, and has an opening through which emitted light may pass, the opening having dimensions of 2 cm in width and 5 cm in length. In another embodiment, the light-absorbing detector filter is substantially rectangular in shape and has outer dimensions in the range of 1-3 cm in width and 2-8 cm in length, and has an opening through which emitted light may pass, the opening having dimensions in the range of 0.25-2 cm in width and 1-4 cm in length. In yet another embodiment, the light-absorbing detector filter is substantially rectangular in shape and has outer dimensions of 3 cm in width and 6 cm in length, and has an opening through which emitted light may pass, the opening having dimensions of 1.5 cm in width and 4 cm in length.

[0039] The top surface of the light-absorbing filter 306 (facing the tissue measurement site 102 and the emitter 302) is coated with a material that absorbs light, such as, for example, black pigment. Many other types of light-absorbing materials are well known in the art and can be used with the detector filter 306. During operation, light emitted from the emitter 302 can reflect off of the tissue measurement site 102 (or other structures within the 3D sensor 300) to neighboring portions of the 3D sensor 300. If those neighboring portions of the 3D sensor 300 possess reflective surfaces, then the light can reflect back to the tissue measurement site 102, progress through the tissue and arrive at the detector 310. Such multiple scattering can result in detecting photons whose pathlengths are considerably longer than most of the light that is detected, thereby introducing variations in pathlength which will affect the accuracy of the measurements of the pulse oximetry 3D sensor 300. Advantageously, the light-absorbing filter 306 reduces or eliminates the amount of emitted light that is reflected in this manner because it absorbs such reflected light, thereby stopping the chain of scattering events. In certain embodiments, the sensor-facing surfaces of other portions of the 3D sensor 300 are covered in light-absorbing material to further decrease the effect of reflective multiple scattering.

[0040] The light concentrator 308 is a structure to receive the emitted optical radiation, after attenuation by the tissue measurement site 102, to collect and concentrate the dispersed optical radiation, and to direct the collected and concentrated optical radiation to the detector 310. In an embodiment, the light concentrator 308 is made of ground glass or glass beads. In some embodiments, the light concentrator 308 includes a compound parabolic concentrator.

[0041] As described above with respect to FIG. 1, the detector 310 captures and measures light from the tissue measurement site 102. For example, the detector 310 can capture and measure light transmitted from the emitter 302 that has been attenuated by the tissue in the measurement site 102. The detector 310 can output a detector signal responsive to the light captured or measured. The detector 310 can be implemented using one or more photodiodes, phototransistors, or the like. In addition, a plurality of detectors 310 can be arranged in an array with a spatial configuration corresponding to the irradiated surface area 206 to capture the attenuated or reflected light from the tissue measurement site.

[0042] Referring to FIG. 4A, a top view of a portion of the 3D sensor 300 is provided. The light-absorbing detector filter 306 is illustrated having a top surface coated with a light-absorbing material. The light-absorbing material can be a black opaque material or coating or any other dark color or coating configured to absorb light. Additionally, a rectangular opening 402 is positioned relative to the light concentrator 308 (shown in phantom) and the detector 310 such that light may pass through the rectangular opening 402, into the light concentrator 308, and to the detector 310. FIG. 4B illustrates the top view of a portion of the 3D sensor 300 as in FIG. 4A, with the addition of the tissue measurement site 102 in operational position. Accordingly, the rectangular opening 402, the light concentrator 308 and the detector 310 are shown in phantom as being under the tissue measurement site 102. In FIGS. 4A and 4B, the light concentrator 308 is shown to have dimensions significantly larger than the dimensions of the rectangular opening 402. In other embodiments, the dimensions of the light concentrator 308, the rectangular opening 402, and the irradiated surface area 206 are substantially similar.

[0043] FIG. 5 illustrates a top view of a 3D pulse oximetry sensor 500 according to an embodiment of the present disclosure. The 3D sensor 500 is configured to be worn on a patient's finger 102. The 3D sensor 500 includes an adhesive substrate 502 having front flaps 504 and rear flaps 506 extending outward from a center portion 508 of the 3D sensor 500. The center portion 508 includes components of the 3D pulse oximetry sensor 300 described with respect to FIGS. 3, 4A and 4B. On the front side of the adhesive substrate 502 the emitter 302 and the light diffuser 304 are positioned. On the rear side of the adhesive substrate 502 the light-absorbent detector filter 306, the light concentrator 308 and the detector 310 are positioned. In use, the patient's finger serving as the tissue measurement site 102 is positioned over the rectangular opening 402 such that when the front portion of the adhesive substrate is folded over on top of the patient's finger 102, the emitter 302 and the light diffuser 304 are aligned with the measurement site 102, the filter 306, the light concentrator 308 and the detector 310. Once alignment is established, the front and rear flaps 504, 506 can be wrapped around the finger measurement site 102 such that the adhesive substrate 502 provides a secure contact between the patient's skin and the 3D sensor 500. Fig. 5 also illustrates an example of a sensor connector cable 510 which is used to connect the 3D sensor 500 to a monitor 809, as described with respect to FIG. 8.

[0044] FIG. 6 is a simplified schematic illustration of a conventional, 2D approach to reflective pulse oximetry in which the emitter is configured to emit optical radiation as a point optical source. Reflective pulse oximetry is a method by which the emitter and detector are located on the same side of the tissue measurement site 102. Light is emitted into a tissue measurement site 102 and attenuated. The emitted light passes into the tissue 102 and is then reflected back to the same side of the tissue measurement site 102 as the emitter. As illustrated in FIG. 6, a depicted reflective 2D pulse oximetry sensor 600 includes an emitter 602, a light block 606, and a detector 610. The light block 606 is necessary because the emitter 602 and the detector 610 are located on the same side of the tissue measurement site 102. Accordingly, the light block 606 prevents incident emitter light, which did not enter the tissue measurement site 102, from arriving at the

detector 610. The depicted 2D pulse oximetry sensor 600 is configured to emit light as a point source. As depicted in FIG. 6, a simplified illustration of the light path 620 of the emitted light from the emitter 602, through the tissue measurement site 102, and to the detector 610 is provided. Notably, a point source of light is emitted, and a point source of light is detected. As discussed above with respect to FIG. 1, use of a point optical source can result in substantial measurement error due to pathlength variability resulting from the multiple scatter phenomenon. The sample space provided by a 2D point optical emitter source is not large enough to account for pathlength variability, which will skew measurement results.

[0045] FIGS. 7A and 7B are simplified schematic side and top views, respectively, of a 3D reflective pulse oximetry sensor 700 according to an embodiment of the present disclosure. In the illustrated embodiment, the 3D sensor 700 irradiates the tissue measurement site 102 and detects the emitted light that is reflected by the tissue measurement site 102. The 3D sensor 700 can be placed on a portion of the patient's body that has relatively flat surface, such as, for example a wrist, because the emitter 702 and detector 710 are on located the same side of the tissue measurement site 102. The 3D sensor 700 includes an emitter 702, a light diffuser 704, a light block 706, a light concentrator 708, and a detector 710.

[0046] As previously described, the emitter 702 can serve as the source of optical radiation transmitted towards the tissue measurement site 102. The emitter 702 can include one or more sources of optical radiation. Such sources of optical radiation can include LEDs, laser diodes, incandescent bulbs with appropriate frequency-selective filters, combinations of the same, or the like. In an embodiment, the emitter 702 includes sets of optical sources that are capable of emitting visible and near-infrared optical radiation. In some embodiments, the emitter 702 transmits optical radiation of red and infrared wavelengths, at approximately 650 nm and approximately 940 nm, respectively. In some embodiments, the emitter 702 includes a single source of optical radiation.

[0047] The light diffuser 704 receives the optical radiation emitted from the emitter 302 and homogenously spreads the optical radiation over a wide, donut-shaped area, such as the area outlined by the light diffuser 704 as depicted in FIG.

7B. Advantageously, the diffuser 704 can receive emitted light in the form of a 2D point optical source (or any other form) and spread the light to fit the desired surface area on a plane defined by the surface of the tissue measurement site 102. In an embodiment, the diffuser 704 is made of ground glass or glass beads. A skilled artisan will understand that many other materials can be used to make the light diffuser 704.

[0048] The light blocker 706 includes an annular ring having a cover portion 707 sized and shaped to form a light isolation chamber for the light concentrator 708 and the detector 710. (For purposes of illustration, the light block cover 707 is not illustrated in FIG. 7B.) The light blocker 706 and the cover 707 can be made of any material that optically isolates the light concentrator 708 and the detector 710. The light isolation chamber formed by the light blocker 706 and cover 708 ensures that the only light detected by the detector 710 is light that is reflected from the tissue measurement site.

[0049] The light concentrator 708 is a cylindrical structure with a truncated circular conical structure on top, the truncated section of which is adjacent the detector 710. The light concentrator 708 is structured to receive the emitted optical radiation, after reflection by the tissue measurement site 102, and to direct the reflected light to the detector 710. In an embodiment, the light concentrator 708 is made of ground glass or glass beads. In some embodiments, the light concentrator 708 includes a compound parabolic concentrator.

[0050] As previously described, the detector 710 captures and measures light from the tissue measurement site 102. For example, the detector 710 can capture and measure light transmitted from the emitter 702 that has been reflected from the tissue in the measurement site 102. The detector 710 can output a detector signal responsive to the light captured or measured. The detector 710 can be implemented using one or more photodiodes, phototransistors, or the like. In addition, a plurality of detectors 710 can be arranged in an array with a spatial configuration corresponding to the irradiated surface area depicted in FIG. 7B by the light concentrator 708 to capture the reflected light from the tissue measurement site.

[0051] Advantageously, the light path 720 illustrated in FIG. 7A depicts a substantial sample of reflected light that enter the light isolation chamber formed by the light blocker 706 and cover 707. As previously discussed, the large sample of reflected light (as compared to the reflected light collected using the 2D point optical source approach) provides the opportunity to take an average of the detected light, to derive a more accurate measurement of the emitted light absorbed by the tissue, which will lead to a more accurate oxygen saturation measurement.

[0052] Referring now to FIG. 7B, a top view of the 3D sensor 700 is illustrated with both the emitter 702 and the light blocker cover 707 removed for ease of illustration. The outer ring illustrates the footprint of the light diffuser 704. As light is emitted from the emitter 702 (not shown in FIG. 7B), it is diffused homogenously and directed to the tissue measurement site 102. The light blocker 706 forms the circular wall of a light isolation chamber to keep incident light from being sensed by the detector 710. The light blocker cover 707 blocks incidental light from entering the light isolation chamber from above. The light concentrator 710 collects the reflected light from the tissue measurement site 102 and funnels it upward toward the detector 710 at the center of the 3D sensor 700.

[0053] FIG. 8 illustrates an example of an optical physiological measurement system 800, which may also be referred to herein as a pulse oximetry system 800. In certain embodiments, the pulse oximetry system 800 noninvasively measures a blood analyte, such as oxygen, carboxyhemoglobin, methemoglobin, total hemoglobin, glucose, proteins, lipids, a percentage thereof (*e.g.*, saturation), pulse rate, perfusion index, oxygen content, total hemoglobin, Oxygen Reserve Index™ (ORI™) or many other physiologically relevant patient characteristics. These characteristics can relate to, for example, pulse rate, hydration, trending information and analysis, and the like. The system 800 can also measure additional blood analytes and/or other physiological parameters useful in determining a state or trend of wellness of a patient.

[0054] The pulse oximetry system 800 can measure analyte concentrations at least in part by detecting optical radiation attenuated by tissue at a

measurement site 102. The measurement site 102 can be any location on a patient's body, such as a finger, foot, earlobe, wrist, forehead, or the like.

[0055] The pulse oximetry system 800 can include a sensor 801 (or multiple sensors) that is coupled to a processing device or physiological monitor 809. In an embodiment, the sensor 801 and the monitor 809 are integrated together into a single unit. In another embodiment, the sensor 801 and the monitor 809 are separate from each other and communicate with one another in any suitable manner, such as via a wired or wireless connection. The sensor 801 and monitor 809 can be attachable and detachable from each other for the convenience of the user or caregiver, for ease of storage, sterility issues, or the like.

[0056] In the depicted embodiment shown in FIG. 8, the sensor 801 includes an emitter 804, a detector 806, and a front-end interface 808. The emitter 804 can serve as the source of optical radiation transmitted towards measurement site 102. The emitter 804 can include one or more sources of optical radiation, such as light emitting diodes (LEDs), laser diodes, incandescent bulbs with appropriate frequency-selective filters, combinations of the same, or the like. In an embodiment, the emitter 804 includes sets of optical sources that are capable of emitting visible and near-infrared optical radiation.

[0057] The pulse oximetry system 800 also includes a driver 811 that drives the emitter 804. The driver 111 can be a circuit or the like that is controlled by the monitor 809. For example, the driver 811 can provide pulses of current to the emitter 804. In an embodiment, the driver 811 drives the emitter 804 in a progressive fashion, such as in an alternating manner. The driver 811 can drive the emitter 804 with a series of pulses for some wavelengths that can penetrate tissue relatively well and for other wavelengths that tend to be significantly absorbed in tissue. A wide variety of other driving powers and driving methodologies can be used in various embodiments. The driver 811 can be synchronized with other parts of the sensor 801 to minimize or reduce jitter in the timing of pulses of optical radiation emitted from the emitter 804. In some embodiments, the driver 811 is capable of driving the emitter 804 to emit optical radiation in a pattern that varies by less than about 10 parts-per-million.

[0058] The detector 806 captures and measures light from the tissue measurement site 102. For example, the detector 806 can capture and measure light transmitted from the emitter 804 that has been attenuated or reflected from the tissue at the measurement site 102. The detector 806 can output a detector signal 107 responsive to the light captured and measured. The detector 806 can be implemented using one or more photodiodes, phototransistors, or the like. In some embodiments, a detector 806 is implemented in detector package to capture and measure light from the tissue measurement site 102 of the patient. The detector package can include a photodiode chip mounted to leads and enclosed in an encapsulant. In some embodiments, the dimensions of the detector package are approximately 2 square centimeters. In other embodiments, the dimensions of the detector package are approximately 1.5 centimeters in width and approximately 2 centimeters in length.

[0059] The front-end interface 808 provides an interface that adapts the output of the detectors 806, which is responsive to desired physiological parameters. For example, the front-end interface 808 can adapt the signal 807 received from the detector 806 into a form that can be processed by the monitor 809, for example, by a signal processor 810 in the monitor 809. The front-end interface 808 can have its components assembled in the sensor 801, in the monitor 809, in a connecting cabling (if used), in combinations of the same, or the like. The location of the front-end interface 808 can be chosen based on various factors including space desired for components, desired noise reductions or limits, desired heat reductions or limits, and the like.

[0060] The front-end interface 808 can be coupled to the detector 806 and to the signal processor 810 using a bus, wire, electrical or optical cable, flex circuit, or some other form of signal connection. The front-end interface 808 can also be at least partially integrated with various components, such as the detectors 806. For example, the front-end interface 808 can include one or more integrated circuits that are on the same circuit board as the detector 806. Other configurations can also be used.

[0061] As shown in FIG. 8, the monitor 909 can include the signal processor 810 and a user interface, such as a display 812. The monitor 809 can also include optional outputs alone or in combination with the display 812, such as a storage device 814 and a network interface 816. In an embodiment, the signal processor 810 includes processing logic that determines measurements for desired analytes based on the signals received from the detector 806. The signal processor 810 can be implemented using one or more microprocessors or sub-processors (*e.g.*, cores), digital signal processors, application specific integrated circuits (ASICs), field programmable gate arrays (FPGAs), combinations of the same, and the like.

[0062] The signal processor 810 can provide various signals that control the operation of the sensor 801. For example, the signal processor 810 can provide an emitter control signal to the driver 811. This control signal can be useful in order to synchronize, minimize, or reduce jitter in the timing of pulses emitted from the emitter 804. Accordingly, this control signal can be useful in order to cause optical radiation pulses emitted from the emitter 804 to follow a precise timing and consistent pattern. For example, when a transimpedance-based front-end interface 808 is used, the control signal from the signal processor 810 can provide synchronization with an analog-to-digital converter (ADC) in order to avoid aliasing, cross-talk, and the like. As also shown, an optional memory 813 can be included in the front-end interface 808 and/or in the signal processor 810. This memory 813 can serve as a buffer or storage location for the front-end interface 808 and/or the signal processor 810, among other uses.

[0063] The user interface 812 can provide an output, *e.g.*, on a display, for presentation to a user of the pulse oximetry system 800. The user interface 812 can be implemented as a touch-screen display, a liquid crystal display (LCD), an organic LED display, or the like. In alternative embodiments, the pulse oximetry system 800 can be provided without a user interface 812 and can simply provide an output signal to a separate display or system.

[0064] The storage device 814 and a network interface 816 represent other optional output connections that can be included in the monitor 809. The

storage device 814 can include any computer-readable medium, such as a memory device, hard disk storage, EEPROM, flash drive, or the like. The various software and/or firmware applications can be stored in the storage device 814, which can be executed by the signal processor 810 or another processor of the monitor 809. The network interface 816 can be a serial bus port (RS-232/RS-485), a Universal Serial Bus (USB) port, an Ethernet port, a wireless interface (*e.g.*, WiFi such as any 802.1x interface, including an internal wireless card), or other suitable communication device(s) that allows the monitor 809 to communicate and share data with other devices. The monitor 809 can also include various other components not shown, such as a microprocessor, graphics processor, or controller to output the user interface 812, to control data communications, to compute data trending, or to perform other operations.

[0065] Although not shown in the depicted embodiment, the pulse oximetry system 800 can include various other components or can be configured in different ways. For example, the sensor 801 can have both the emitter 804 and detector 806 on the same side of the tissue measurement site 102 and use reflectance to measure analytes.

[0066] Although the foregoing disclosure has been described in terms of certain preferred embodiments, many other variations than those described herein will be apparent to those of ordinary skill in the art.

[0067] Conditional language used herein, such as, among others, "can," "might," "may," "*e.g.*," and the like, unless specifically stated otherwise, or otherwise understood within the context as used, is generally intended to convey that certain embodiments include, while other embodiments do not include, certain features, elements and/or states. Thus, such conditional language is not generally intended to imply that features, elements and/or states are in any way required for one or more embodiments or that one or more embodiments necessarily include logic for deciding, with or without author input or prompting, whether these features, elements and/or states are included or are to be performed in any particular embodiment. The terms "comprising," "including," "having," and the like are synonymous and are used inclusively, in an open-ended fashion, and do not

exclude additional elements, features, acts, operations, and so forth. Also, the term "or" is used in its inclusive sense (and not in its exclusive sense) so that when used, for example, to connect a list of elements, the term "or" means one, some, or all of the elements in the list. Further, the term "each," as used herein, in addition to having its ordinary meaning, can mean any subset of a set of elements to which the term "each" is applied.

[0068] While the above detailed description has shown, described, and pointed out novel features as applied to various embodiments, it will be understood that various omissions, substitutions, and changes in the form and details of the systems, devices or algorithms illustrated can be made without departing from the spirit of the disclosure. As will be recognized, certain embodiments of the disclosure described herein can be embodied within a form that does not provide all of the features and benefits set forth herein, as some features can be used or practiced separately from others.

[0069] The term "and/or" herein has its broadest, least limiting meaning which is the disclosure includes A alone, B alone, both A and B together, or A or B alternatively, but does not require both A and B or require one of A or one of B. As used herein, the phrase "at least one of" A, B, "and" C should be construed to mean a logical A or B or C, using a non-exclusive logical or.

[0070] The apparatuses and methods described herein may be implemented by one or more computer programs executed by one or more processors. The computer programs include processor-executable instructions that are stored on a non-transitory tangible computer readable medium. The computer programs may also include stored data. Non-limiting examples of the non-transitory tangible computer readable medium are nonvolatile memory, magnetic storage, and optical storage. Although the foregoing disclosure has been described in terms of certain preferred embodiments, other embodiments will be apparent to those of ordinary skill in the art from the disclosure herein. Additionally, other combinations, omissions, substitutions and modifications will be apparent to the skilled artisan in view of the disclosure herein. Accordingly, the present invention is not intended to

be limited by the description of the preferred embodiments, but is to be defined by reference to claims.

[0071] Additionally, all publications, patents, and patent applications mentioned in this specification are herein incorporated by reference to the same extent as if each individual publication, patent, or patent application were specifically and individually indicated to be incorporated by reference.

WHAT IS CLAIMED IS:

1. An optical physiological measurement system comprising:
 - an emitter which emits light of a wavelength;
 - a diffuser which receives, spreads and emits the spread light, wherein the emitted spread light is directed at a tissue measurement site of a patient;
 - and
 - a detector configured to detect the emitted light after attenuation by tissue of the patient, the detector further configured to transmit a signal responsive to the detected light.
2. The optical physiological measurement system of Claim 1, further comprising a concentrator which receives the spread light after attenuation by tissue of the patient, concentrates the received spread light and emits the concentrated light in the direction of the detector.
3. The optical physiological measurement system of Claim 1, further comprising a processor configured to receive the transmitted signal responsive to the detected light and to determine a physiological parameter.
4. The optical physiological measurement system of Claim 3, wherein the parameter is arterial oxygen saturation.
5. The optical physiological measurement system of Claim 1, wherein the diffuser comprises at least one of a glass diffuser, ground glass diffuser, a glass bead diffuser, an opal glass diffuser, and an engineered diffuser.
6. The optical physiological measurement system of Claim 1, wherein the diffuser emits the spread light with a substantially uniform intensity profile.
7. The optical physiological measurement system of Claim 1, wherein the diffuser defines a surface area shape by which the emitted spread light is distributed onto a surface of the tissue measurement site.
8. The optical physiological monitor of Claim 7, further comprising a detector filter having a light-absorbing surface facing the tissue measurement site and an opening, the opening having dimensions, wherein the dimensions of the opening are substantially similar to the defined surface area shape by which the emitted spread light is distributed onto the surface of the tissue measurement site.

9. The optical physiological measurement system of Claim 7, wherein the surface area shape is rectangular.

10. The optical physiological measurement system of Claim 9, wherein the rectangular surface area shape has dimensions within a range of approximately 0.25 cm to 3 cm in width and a range of approximately 1 cm to 6 cm in length.

11. The optical physiological measurement system of Claim 9, wherein the rectangular surface area shape has dimensions in the range of approximately 0.1 cm to 2 cm in width and approximately 0.5 cm to 5 cm in length.

12. The optical physiological measurement system of Claim 9, wherein the rectangular surface area shape has dimensions of approximately 1 centimeter in width and approximately 1.5 centimeters in length.

13. The optical physiological measurement system of Claim 7, wherein the surface area shape is square.

14. The optical physiological measurement system of Claim 13, wherein the square surface area shape has dimensions in the range of approximately 0.25 cm² to 10 cm².

15. The optical physiological measurement system of Claim 9, further comprising a detector filter comprising a light-absorbing surface facing the tissue measurement site and an opening, the opening having dimensions, wherein the dimensions of the opening are substantially similar to dimensions of the rectangular shape.

16. The optical physiological measurement system of Claim 1, wherein the concentrator comprises at least one of glass, ground glass, glass beads, opal glass, and a compound parabolic concentrator.

17. The optical physiological measurement system of Claim 1, further comprising a detector filter comprising a light-absorbing surface facing the tissue measurement site and an opening, wherein the opening is configured to allow the spread light, after being attenuated by or reflected from the tissue measurement site, to be received by the concentrator.

18. A method to determine a constituent or analyte in a patient's blood, the method comprising:

emitting, from an emitter, light of a wavelength;

spreading, with a diffuser, the emitted light and emitting the spread light from the diffuser to a tissue measurement site, wherein the diffuser spreads the light over a greater area of the tissue measurement site than would otherwise be illuminated by the emitter directly emitting light at a tissue measurement site; and

detecting, with the detector, the emitted concentrated light.

19. The method of Claim 18, further comprising receiving, by a concentrator, the emitted spread light after the spread light has been attenuated by or reflected from the tissue measurement site and concentrating, by the concentrator, the received light and emitting the concentrated light from the concentrator to a detector.

20. The method of Claim 18, further comprising transmitting, from the detector, a signal responsive to the detected light; receiving, by a processor, the transmitted signal responsive to the detected light; and processing, by the processor, the received signal responsive to the detected light to determine a physiological parameter.

21. The method of Claim 18, further comprising filtering, with a light-absorbing detector filter, scattered portions of the emitted spread light.

22. The method of Claim 18, wherein spreading, with a diffuser, the emitted light and emitting the spread light from the diffuser to a tissue measurement site is performed by at least one of a glass diffuser, a glass bead diffuser, an opal glass diffuser, and an engineered diffuser.

23. The method of Claim 18, wherein spreading, with a diffuser, the emitted light and emitting the spread light from the diffuser to a tissue measurement site further comprises spreading the emitted light with a substantially uniform intensity profile.

24. The method of Claim 18, wherein spreading, with a diffuser, the emitted light and emitting the spread light from the diffuser to a tissue measurement site further comprises spreading the emitted light so as to define a surface area

shape by which the emitted spread light is distributed onto a surface of the tissue measurement site.

25. The method of Claim 18, wherein concentrating, by the concentrator, the received light and emitting the concentrated light from the concentrator to a detector is performed by at least one of a glass concentrator, a glass bead concentrator, an opal glass concentrator, and a compound parabolic concentrator.

26. A pulse oximeter sensor comprising:
an emitter configured to emit light at a wavelength;
a diffuser configured to receive the emitted light, to spread the received light, and to emit the spread light, wherein the emitted spread light is directed at a tissue measurement site; and
a detector configured to detect the emitted spread light, the spread light having been attenuated by the tissue measurement site, the detector further configured to output a signal responsive to the detected light.

27. The pulse oximeter sensor of Claim 26, further comprising a concentrator which concentrates the emitted light after it has been attenuated by the tissue measurement site and directs the concentrated light toward the detector.

28. The pulse oximeter sensor of Claim 26, wherein the detector is further configured to output the signal response to the detected light to a processor configured to receive the signal responsive to the detected light and to determine a physiological parameter.

29. The pulse oximeter sensor of Claim 26, wherein the diffuser is further configured to define a surface area shape by which the emitted spread light is distributed onto a surface of the tissue measurement site.

30. The pulse oximeter sensor of Claim 29, wherein the detector is further configured to have a detection area corresponding to the defined surface area shape by which the emitted spread light is distributed onto the surface of the tissue measurement site.

31. The pulse oximeter sensor of Claim 30, wherein the detector further comprises an array of detectors configured to cover the detection area.

32. A pulse oximeter sensor comprising:

an emitter configured to emit light at a wavelength;
a concentrator which concentrates the emitted light after it has been attenuated by the tissue measurement site; and
a detector configured to detect the emitted spread, the spread light having been attenuated by or reflected from the tissue measurement site, the detector further configured to output a signal responsive to the detected light.

33. The pulse oximeter sensor of Claim 32, wherein the detector is further configured to transmit the output signal responsive to the detected light to a processor configured to receive the signal responsive to the detected light and to determine a physiological parameter.

34. The pulse oximeter sensor of Claim 32, wherein the concentrator is further configured to define a surface area shape by which the emitted spread light is received from a surface of the tissue measurement site.

35. The pulse oximeter sensor of Claim 34, wherein the concentrator is further configured to have a detection area corresponding to the defined surface area shape by which the emitted spread light is distributed onto the surface of the tissue measurement site.

36. The pulse oximeter sensor of Claim 35, wherein the detector further comprises an array of detectors configured to cover the detection area.

ABSTRACT OF THE DISCLOSURE

A non-invasive, optical-based physiological monitoring system is disclosed. One embodiment includes an emitter configured to emit light. A diffuser is configured to receive and spread the emitted light, and to emit the spread light at a tissue measurement site. The system further includes a concentrator configured to receive the spread light after it has been attenuated by or reflected from the tissue measurement site. The concentrator is also configured to collect and concentrate the received light and to emit the concentrated light to a detector. The detector is configured to detect the concentrated light and to transmit a signal representative of the detected light. A processor is configured to receive the transmitted signal and to determine a physiological parameter, such as, for example, arterial oxygen saturation, in the tissue measurement site.

23597505

Electronic Patent Application Fee Transmittal				
Application Number:				
Filing Date:				
Title of Invention:	ADVANCED PULSE OXIMETRY SENSOR			
First Named Inventor/Applicant Name:	Ammar Al-Ali			
Filer:	Jarom D. Kesler/Stacy Ho			
Attorney Docket Number:	MASIMO.1007A			
Filed as Large Entity				
Filing Fees for Utility under 35 USC 111(a)				
Description	Fee Code	Quantity	Amount	Sub-Total in USD(\$)
Basic Filing:				
Utility application filing	1011	1	280	280
Utility Search Fee	1111	1	600	600
Utility Examination Fee	1311	1	720	720
Pages:				
Claims:				
Claims in Excess of 20	1202	16	80	1280
Independent claims in excess of 3	1201	1	420	420
Miscellaneous-Filing:				

Description	Fee Code	Quantity	Amount	Sub-Total in USD(\$)
Late Filing Fee for Oath or Declaration	1051	1	140	140
Petition:				
Patent-Appeals-and-Interference:				
Post-Allowance-and-Post-Issuance:				
Extension-of-Time:				
Miscellaneous:				
Total in USD (\$)				3440

Electronic Acknowledgement Receipt	
EFS ID:	26195690
Application Number:	15195199
International Application Number:	
Confirmation Number:	3453
Title of Invention:	ADVANCED PULSE OXIMETRY SENSOR
First Named Inventor/Applicant Name:	Ammar Al-Ali
Customer Number:	64735
Filer:	Jarom D. Kesler/Heather OBrien
Filer Authorized By:	Jarom D. Kesler
Attorney Docket Number:	MASIMO.1007A
Receipt Date:	28-JUN-2016
Filing Date:	
Time Stamp:	15:19:28
Application Type:	Utility under 35 USC 111(a)

Payment information:

Submitted with Payment	yes
Payment Type	CARD
Payment was successfully received in RAM	\$3440
RAM confirmation Number	062916INTEFSW15204400
Deposit Account	2598
Authorized User	Heather OBrien
The Director of the USPTO is hereby authorized to charge indicated fees and credit any overpayment as follows:	

File Listing:					
Document Number	Document Description	File Name	File Size(Bytes)/ Message Digest	Multi Part /.zip	Pages (if appl.)
1	Application Data Sheet	MASIMO_1007A_ADS.pdf	1823134	no	8
			6220fce4fc99ce4f0d70fe10b394dd51402332f3		
Warnings:					
Information:					
2	Drawings-only black and white line drawings	MASIMO_1007A_Drawings.pdf	228624	no	7
			ce66a69576ddc1dd5e49f14da746e9c185e9bfe7		
Warnings:					
Information:					
3	Power of Attorney	MASIMO_1007A_POA.pdf	334545	no	3
			7a74175ec7061492939e0b9ab8771a38a17f04ba		
Warnings:					
Information:					
4		MASIMO_1007A_IDS.pdf	225303	yes	26
			7088e979265b57a156b70f9e775447b99300e1ee0		
	Multipart Description/PDF files in .zip description				
	Document Description		Start	End	
	Transmittal Letter		1	2	
	Information Disclosure Statement (IDS) Form (SB08)		3	26	
Warnings:					
Information:					
5		MASIMO_1007A_Spec.pdf	163945	yes	30
			5b18cf1b9330564aa31c88915998ab3fe625fa14		

Multipart Description/PDF files in .zip description					
Document Description			Start	End	
Specification			1	24	
Claims			25	29	
Abstract			30	30	
Warnings:					
Information:					
6	Fee Worksheet (SB06)	fee-info.pdf	39826	no	2
			c2108147f6a635f07ccbb3e27623b2f59a2ab		
Warnings:					
Information:					
Total Files Size (in bytes):			2815377		
<p>This Acknowledgement Receipt evidences receipt on the noted date by the USPTO of the indicated documents, characterized by the applicant, and including page counts, where applicable. It serves as evidence of receipt similar to a Post Card, as described in MPEP 503.</p> <p><u>New Applications Under 35 U.S.C. 111</u> If a new application is being filed and the application includes the necessary components for a filing date (see 37 CFR 1.53(b)-(d) and MPEP 506), a Filing Receipt (37 CFR 1.54) will be issued in due course and the date shown on this Acknowledgement Receipt will establish the filing date of the application.</p> <p><u>National Stage of an International Application under 35 U.S.C. 371</u> If a timely submission to enter the national stage of an international application is compliant with the conditions of 35 U.S.C. 371 and other applicable requirements a Form PCT/DO/EO/903 indicating acceptance of the application as a national stage submission under 35 U.S.C. 371 will be issued in addition to the Filing Receipt, in due course.</p> <p><u>New International Application Filed with the USPTO as a Receiving Office</u> If a new international application is being filed and the international application includes the necessary components for an international filing date (see PCT Article 11 and MPEP 1810), a Notification of the International Application Number and of the International Filing Date (Form PCT/RO/105) will be issued in due course, subject to prescriptions concerning national security, and the date shown on this Acknowledgement Receipt will establish the international filing date of the application.</p>					

Under the Paperwork Reduction Act of 1995, no persons are required to respond to a collection of information unless it contains a valid OMB control number.

Application Data Sheet 37 CFR 1.76		Attorney Docket Number	MASIMO.1007A
		Application Number	
Title of Invention	ADVANCED PULSE OXIMETRY SENSOR		
The application data sheet is part of the provisional or nonprovisional application for which it is being submitted. The following form contains the bibliographic data arranged in a format specified by the United States Patent and Trademark Office as outlined in 37 CFR 1.76. This document may be completed electronically and submitted to the Office in electronic format using the Electronic Filing System (EFS) or the document may be printed and included in a paper filed application.			

Secrecy Order 37 CFR 5.2:

Portions or all of the application associated with this Application Data Sheet may fall under a Secrecy Order pursuant to 37 CFR 5.2 (Paper filers only. Applications that fall under Secrecy Order may not be filed electronically.)

Inventor Information:

Inventor 1					Remove
Legal Name					
Prefix	Given Name	Middle Name	Family Name	Suffix	
	Ammar		Al-Ali		
Residence Information (Select One) <input checked="" type="radio"/> US Residency <input type="radio"/> Non US Residency <input type="radio"/> Active US Military Service					
City	San Juan Capistrano	State/Province	CA	Country of Residence	US
Mailing Address of Inventor:					
Address 1	30312 Via Bella				
Address 2					
City	San Juan Capistrano	State/Province	CA		
Postal Code	92675	Country i	US		
Inventor 2					Remove
Legal Name					
Prefix	Given Name	Middle Name	Family Name	Suffix	
	Stephen		Scruggs		
Residence Information (Select One) <input checked="" type="radio"/> US Residency <input type="radio"/> Non US Residency <input type="radio"/> Active US Military Service					
City	Newport Beach	State/Province	CA	Country of Residence	US
Mailing Address of Inventor:					
Address 1	307 Snug Harbor Road				
Address 2					
City	Newport Beach	State/Province	CA		
Postal Code	92663	Country i	US		
All Inventors Must Be Listed - Additional Inventor Information blocks may be generated within this form by selecting the Add button.					
Add					

Correspondence Information:

Enter either Customer Number or complete the Correspondence Information section below.
 For further information see 37 CFR 1.33(a).

Under the Paperwork Reduction Act of 1995, no persons are required to respond to a collection of information unless it contains a valid OMB control number.

Application Data Sheet 37 CFR 1.76		Attorney Docket Number	MASIMO.1007A
		Application Number	
Title of Invention	ADVANCED PULSE OXIMETRY SENSOR		

An Address is being provided for the correspondence information of this application.

Customer Number	64735		
Email Address	efiling@knobbe.com	<input type="button" value="Add Email"/>	<input type="button" value="Remove Email"/>

Application Information:

Title of the Invention	ADVANCED PULSE OXIMETRY SENSOR		
Attorney Docket Number	MASIMO.1007A	Small Entity Status Claimed	<input type="checkbox"/>
Application Type	Nonprovisional		
Subject Matter	Utility		
Total Number of Drawing Sheets (if any)	7	Suggested Figure for Publication (if any)	

Filing By Reference:

Only complete this section when filing an application by reference under 35 U.S.C. 111(c) and 37 CFR 1.57(a). Do not complete this section if application papers including a specification and any drawings are being filed. Any domestic benefit or foreign priority information must be provided in the appropriate section(s) below (i.e., "Domestic Benefit/National Stage Information" and "Foreign Priority Information").

For the purposes of a filing date under 37 CFR 1.53(b), the description and any drawings of the present application are replaced by this reference to the previously filed application, subject to conditions and requirements of 37 CFR 1.57(a).

Application number of the previously filed application	Filing date (YYYY-MM-DD)	Intellectual Property Authority or Country

Publication Information:

Request Early Publication (Fee required at time of Request 37 CFR 1.219)

Request Not to Publish. I hereby request that the attached application not be published under 35 U.S.C. 122(b) and certify that the invention disclosed in the attached application **has not and will not** be the subject of an application filed in another country, or under a multilateral international agreement, that requires publication at eighteen months after filing.

Representative Information:

Representative information should be provided for all practitioners having a power of attorney in the application. Providing this information in the Application Data Sheet does not constitute a power of attorney in the application (see 37 CFR 1.32). Either enter Customer Number or complete the Representative Name section below. If both sections are completed the customer Number will be used for the Representative Information during processing.

Please Select One:	<input checked="" type="radio"/> Customer Number	<input type="radio"/> US Patent Practitioner	<input type="radio"/> Limited Recognition (37 CFR 11.9)
Customer Number	64735		

Under the Paperwork Reduction Act of 1995, no persons are required to respond to a collection of information unless it contains a valid OMB control number.

Application Data Sheet 37 CFR 1.76		Attorney Docket Number	MASIMO.1007A
		Application Number	
Title of Invention	ADVANCED PULSE OXIMETRY SENSOR		

Domestic Benefit/National Stage Information:

This section allows for the applicant to either claim benefit under 35 U.S.C. 119(e), 120, 121, 365(c), or 386(c) or indicate National Stage entry from a PCT application. Providing benefit claim information in the Application Data Sheet constitutes the specific reference required by 35 U.S.C. 119(e) or 120, and 37 CFR 1.78. When referring to the current application, please leave the "Application Number" field blank.

Prior Application Status	Pending	<input type="button" value="Remove"/>	
Application Number	Continuity Type	Prior Application Number	Filing or 371(c) Date (YYYY-MM-DD)
	Claims benefit of provisional	62/188430	2015-07-02
Additional Domestic Benefit/National Stage Data may be generated within this form by selecting the Add button.			<input type="button" value="Add"/>

Foreign Priority Information:

This section allows for the applicant to claim priority to a foreign application. Providing this information in the application data sheet constitutes the claim for priority as required by 35 U.S.C. 119(b) and 37 CFR 1.55. When priority is claimed to a foreign application that is eligible for retrieval under the priority document exchange program (PDX)ⁱ the information will be used by the Office to automatically attempt retrieval pursuant to 37 CFR 1.55(i)(1) and (2). Under the PDX program, applicant bears the ultimate responsibility for ensuring that a copy of the foreign application is received by the Office from the participating foreign intellectual property office, or a certified copy of the foreign priority application is filed, within the time period specified in 37 CFR 1.55(g)(1).

Application Number	Country ⁱ	Filing Date (YYYY-MM-DD)	Access Code ⁱ (if applicable)	<input type="button" value="Remove"/>
Additional Foreign Priority Data may be generated within this form by selecting the Add button.				<input type="button" value="Add"/>

Statement under 37 CFR 1.55 or 1.78 for AIA (First Inventor to File) Transition Applications

This application (1) claims priority to or the benefit of an application filed before March 16, 2013 and (2) also contains, or contained at any time, a claim to a claimed invention that has an effective filing date on or after March 16, 2013.

NOTE: By providing this statement under 37 CFR 1.55 or 1.78, this application, with a filing date on or after March 16, 2013, will be examined under the first inventor to file provisions of the AIA.

Under the Paperwork Reduction Act of 1995, no persons are required to respond to a collection of information unless it contains a valid OMB control number.

Application Data Sheet 37 CFR 1.76		Attorney Docket Number	MASIMO.1007A
		Application Number	
Title of Invention	ADVANCED PULSE OXIMETRY SENSOR		

Authorization or Opt-Out of Authorization to Permit Access:

When this Application Data Sheet is properly signed and filed with the application, applicant has provided written authority to permit a participating foreign intellectual property (IP) office access to the instant application-as-filed (see paragraph A in subsection 1 below) and the European Patent Office (EPO) access to any search results from the instant application (see paragraph B in subsection 1 below).

Should applicant choose not to provide an authorization identified in subsection 1 below, applicant **must opt-out** of the authorization by checking the corresponding box A or B or both in subsection 2 below.

NOTE: This section of the Application Data Sheet is **ONLY** reviewed and processed with the **INITIAL** filing of an application. After the initial filing of an application, an Application Data Sheet cannot be used to provide or rescind authorization for access by a foreign IP office(s). Instead, Form PTO/SB/39 or PTO/SB/69 must be used as appropriate.

1. Authorization to Permit Access by a Foreign Intellectual Property Office(s)

A. Priority Document Exchange (PDX) - Unless box A in subsection 2 (opt-out of authorization) is checked, the undersigned hereby **grants the USPTO authority** to provide the European Patent Office (EPO), the Japan Patent Office (JPO), the Korean Intellectual Property Office (KIPO), the State Intellectual Property Office of the People's Republic of China (SIPO), the World Intellectual Property Organization (WIPO), and any other foreign intellectual property office participating with the USPTO in a bilateral or multilateral priority document exchange agreement in which a foreign application claiming priority to the instant patent application is filed, access to: (1) the instant patent application-as-filed and its related bibliographic data, (2) any foreign or domestic application to which priority or benefit is claimed by the instant application and its related bibliographic data, and (3) the date of filing of this Authorization. See 37 CFR 1.14(h)(1).

B. Search Results from U.S. Application to EPO - Unless box B in subsection 2 (opt-out of authorization) is checked, the undersigned hereby **grants the USPTO authority** to provide the EPO access to the bibliographic data and search results from the instant patent application when a European patent application claiming priority to the instant patent application is filed. See 37 CFR 1.14(h)(2).

The applicant is reminded that the EPO's Rule 141(1) EPC (European Patent Convention) requires applicants to submit a copy of search results from the instant application without delay in a European patent application that claims priority to the instant application.

2. Opt-Out of Authorizations to Permit Access by a Foreign Intellectual Property Office(s)

A. Applicant **DOES NOT** authorize the USPTO to permit a participating foreign IP office access to the instant application-as-filed. If this box is checked, the USPTO will not be providing a participating foreign IP office with any documents and information identified in subsection 1A above.

B. Applicant **DOES NOT** authorize the USPTO to transmit to the EPO any search results from the instant patent application. If this box is checked, the USPTO will not be providing the EPO with search results from the instant application.

NOTE: Once the application has published or is otherwise publicly available, the USPTO may provide access to the application in accordance with 37 CFR 1.14.

Under the Paperwork Reduction Act of 1995, no persons are required to respond to a collection of information unless it contains a valid OMB control number.

Application Data Sheet 37 CFR 1.76	Attorney Docket Number	MASIMO.1007A
	Application Number	
Title of Invention	ADVANCED PULSE OXIMETRY SENSOR	

Applicant Information:

Providing assignment information in this section does not substitute for compliance with any requirement of part 3 of Title 37 of CFR to have an assignment recorded by the Office.

Applicant	1	<input type="button" value="Remove"/>
If the applicant is the inventor (or the remaining joint inventor or inventors under 37 CFR 1.45), this section should not be completed. The information to be provided in this section is the name and address of the legal representative who is the applicant under 37 CFR 1.43; or the name and address of the assignee, person to whom the inventor is under an obligation to assign the invention, or person who otherwise shows sufficient proprietary interest in the matter who is the applicant under 37 CFR 1.46. If the applicant is an applicant under 37 CFR 1.46 (assignee, person to whom the inventor is obligated to assign, or person who otherwise shows sufficient proprietary interest) together with one or more joint inventors, then the joint inventor or inventors who are also the applicant should be identified in this section.		
<input type="button" value="Clear"/>		
<input checked="" type="radio"/> Assignee	Legal Representative under 35 U.S.C. 117	Joint Inventor
Person to whom the inventor is obligated to assign.		Person who shows sufficient proprietary interest
If applicant is the legal representative, indicate the authority to file the patent application, the inventor is:		
<div style="border: 1px solid black; height: 20px; width: 100%;"></div>		
Name of the Deceased or Legally Incapacitated Inventor: <input type="text"/>		
If the Applicant is an Organization check here. <input checked="" type="checkbox"/>		
Organization Name	MASIMO CORPORATION	
Mailing Address Information For Applicant:		
Address 1	52 Discovery	
Address 2		
City	Irvine	State/Province CA
Country	US	Postal Code 92618
Phone Number		Fax Number
Email Address		
Additional Applicant Data may be generated within this form by selecting the Add button. <input type="button" value="Add"/>		

Assignee Information including Non-Applicant Assignee Information:

Providing assignment information in this section does not substitute for compliance with any requirement of part 3 of Title 37 of CFR to have an assignment recorded by the Office.

Under the Paperwork Reduction Act of 1995, no persons are required to respond to a collection of information unless it contains a valid OMB control number.

Application Data Sheet 37 CFR 1.76	Attorney Docket Number	MASIMO.1007A
	Application Number	
Title of Invention	ADVANCED PULSE OXIMETRY SENSOR	

Assignee | 1

Complete this section if assignee information, including non-applicant assignee information, is desired to be included on the patent application publication. An assignee-applicant identified in the "Applicant Information" section will appear on the patent application publication as an applicant. For an assignee-applicant, complete this section only if identification as an assignee is also desired on the patent application publication.

If the Assignee or Non-Applicant Assignee is an Organization check here.

Prefix	Given Name	Middle Name	Family Name	Suffix

Mailing Address Information For Assignee including Non-Applicant Assignee:

Address 1				
Address 2				
City		State/Province		
Country ⁱ		Postal Code		
Phone Number		Fax Number		
Email Address				

Additional Assignee or Non-Applicant Assignee Data may be generated within this form by selecting the Add button.

Signature:

NOTE: This Application Data Sheet must be signed in accordance with 37 CFR 1.33(b). However, if this Application Data Sheet is submitted with the INITIAL filing of the application and either box A or B is not checked in subsection 2 of the "Authorization or Opt-Out of Authorization to Permit Access" section, then this form must also be signed in accordance with 37 CFR 1.14(c).

This Application Data Sheet **must** be signed by a patent practitioner if one or more of the applicants is a **juristic entity** (e.g., corporation or association). If the applicant is two or more joint inventors, this form must be signed by a patent practitioner, **all** joint inventors who are the applicant, or one or more joint inventor-applicants who have been given power of attorney (e.g., see USPTO Form PTO/AIA/81) on behalf of **all** joint inventor-applicants.

See 37 CFR 1.4(d) for the manner of making signatures and certifications.

Signature	/Jarom Kesler/		Date (YYYY-MM-DD)	2016-06-28
First Name	Jarom	Last Name	Kesler	Registration Number
				57046

Additional Signature may be generated within this form by selecting the Add button.

Under the Paperwork Reduction Act of 1995, no persons are required to respond to a collection of information unless it contains a valid OMB control number.

Application Data Sheet 37 CFR 1.76	Attorney Docket Number	MASIMO.1007A
	Application Number	
Title of Invention	ADVANCED PULSE OXIMETRY SENSOR	

This collection of information is required by 37 CFR 1.76. The information is required to obtain or retain a benefit by the public which is to file (and by the USPTO to process) an application. Confidentiality is governed by 35 U.S.C. 122 and 37 CFR 1.14. This collection is estimated to take 23 minutes to complete, including gathering, preparing, and submitting the completed application data sheet form to the USPTO. Time will vary depending upon the individual case. Any comments on the amount of time you require to complete this form and/or suggestions for reducing this burden, should be sent to the Chief Information Officer, U.S. Patent and Trademark Office, U.S. Department of Commerce, P.O. Box 1450, Alexandria, VA 22313-1450. DO NOT SEND FEES OR COMPLETED FORMS TO THIS ADDRESS. **SEND TO: Commissioner for Patents, P.O. Box 1450, Alexandria, VA 22313-1450.**

Privacy Act Statement

The Privacy Act of 1974 (P.L. 93-579) requires that you be given certain information in connection with your submission of the attached form related to a patent application or patent. Accordingly, pursuant to the requirements of the Act, please be advised that: (1) the general authority for the collection of this information is 35 U.S.C. 2(b)(2); (2) furnishing of the information solicited is voluntary; and (3) the principal purpose for which the information is used by the U.S. Patent and Trademark Office is to process and/or examine your submission related to a patent application or patent. If you do not furnish the requested information, the U.S. Patent and Trademark Office may not be able to process and/or examine your submission, which may result in termination of proceedings or abandonment of the application or expiration of the patent.

The information provided by you in this form will be subject to the following routine uses:

1. The information on this form will be treated confidentially to the extent allowed under the Freedom of Information Act (5 U.S.C. 552) and the Privacy Act (5 U.S.C. 552a). Records from this system of records may be disclosed to the Department of Justice to determine whether the Freedom of Information Act requires disclosure of these records.
2. A record from this system of records may be disclosed, as a routine use, in the course of presenting evidence to a court, magistrate, or administrative tribunal, including disclosures to opposing counsel in the course of settlement negotiations.
3. A record in this system of records may be disclosed, as a routine use, to a Member of Congress submitting a request involving an individual, to whom the record pertains, when the individual has requested assistance from the Member with respect to the subject matter of the record.
4. A record in this system of records may be disclosed, as a routine use, to a contractor of the Agency having need for the information in order to perform a contract. Recipients of information shall be required to comply with the requirements of the Privacy Act of 1974, as amended, pursuant to 5 U.S.C. 552a(m).
5. A record related to an International Application filed under the Patent Cooperation Treaty in this system of records may be disclosed, as a routine use, to the International Bureau of the World Intellectual Property Organization, pursuant to the Patent Cooperation Treaty.
6. A record in this system of records may be disclosed, as a routine use, to another federal agency for purposes of National Security review (35 U.S.C. 181) and for review pursuant to the Atomic Energy Act (42 U.S.C. 218(c)).
7. A record from this system of records may be disclosed, as a routine use, to the Administrator, General Services, or his/her designee, during an inspection of records conducted by GSA as part of that agency's responsibility to recommend improvements in records management practices and programs, under authority of 44 U.S.C. 2904 and 2906. Such disclosure shall be made in accordance with the GSA regulations governing inspection of records for this purpose, and any other relevant (i.e., GSA or Commerce) directive. Such disclosure shall not be used to make determinations about individuals.
8. A record from this system of records may be disclosed, as a routine use, to the public after either publication of the application pursuant to 35 U.S.C. 122(b) or issuance of a patent pursuant to 35 U.S.C. 151. Further, a record may be disclosed, subject to the limitations of 37 CFR 1.14, as a routine use, to the public if the record was filed in an application which became abandoned or in which the proceedings were terminated and which application is referenced by either a published application, an application open to public inspections or an issued patent.
9. A record from this system of records may be disclosed, as a routine use, to a Federal, State, or local law enforcement agency, if the USPTO becomes aware of a violation or potential violation of law or regulation.

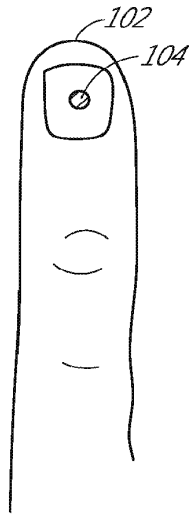

FIG. 1
(PRIOR ART)

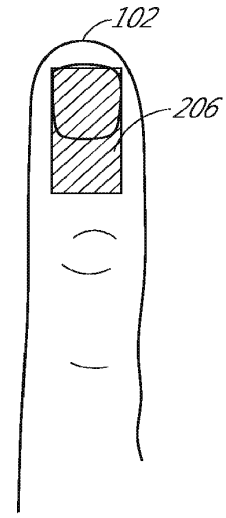

FIG. 2

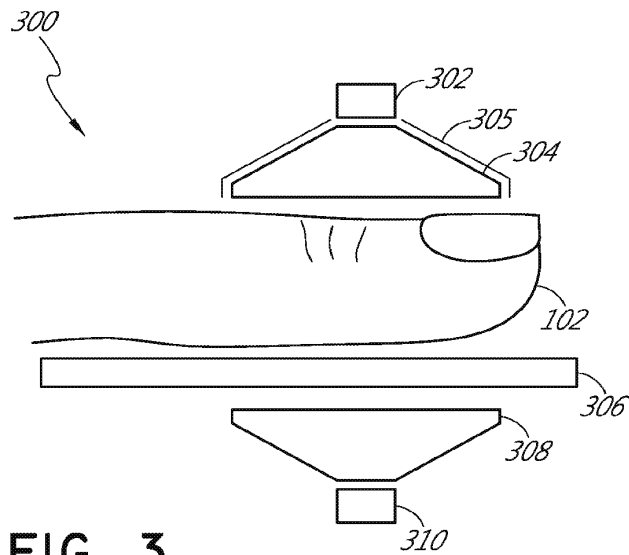

FIG. 3

2/7

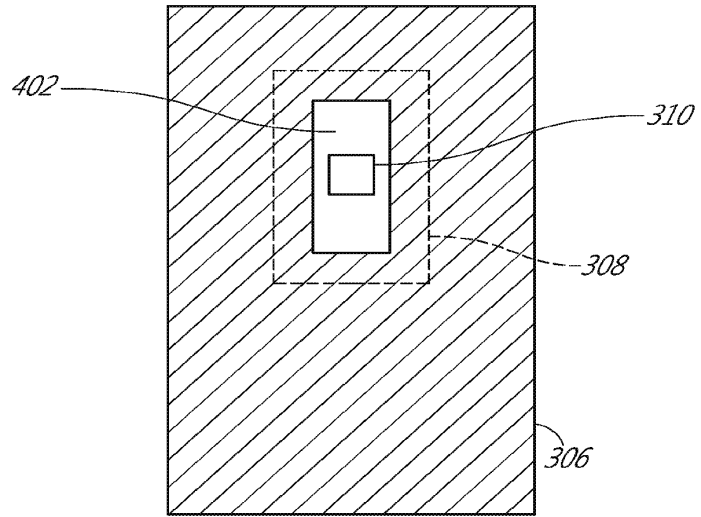

FIG. 4A

3/7

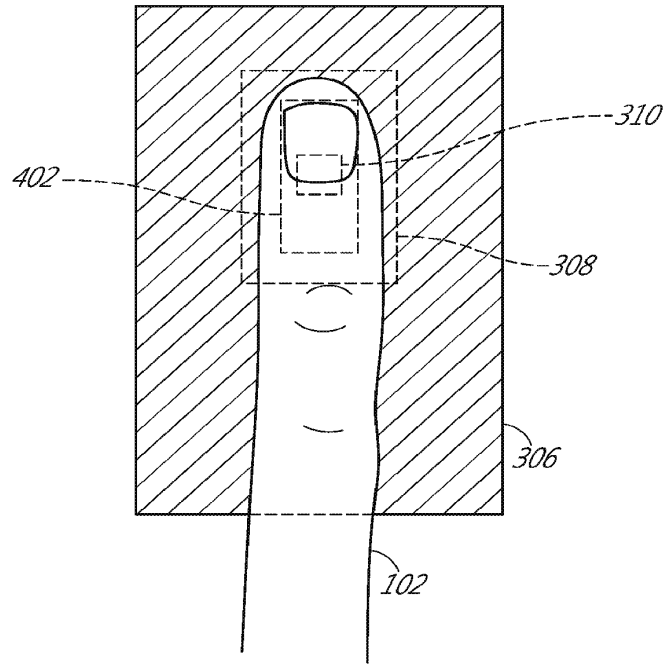

FIG. 4B

4/7

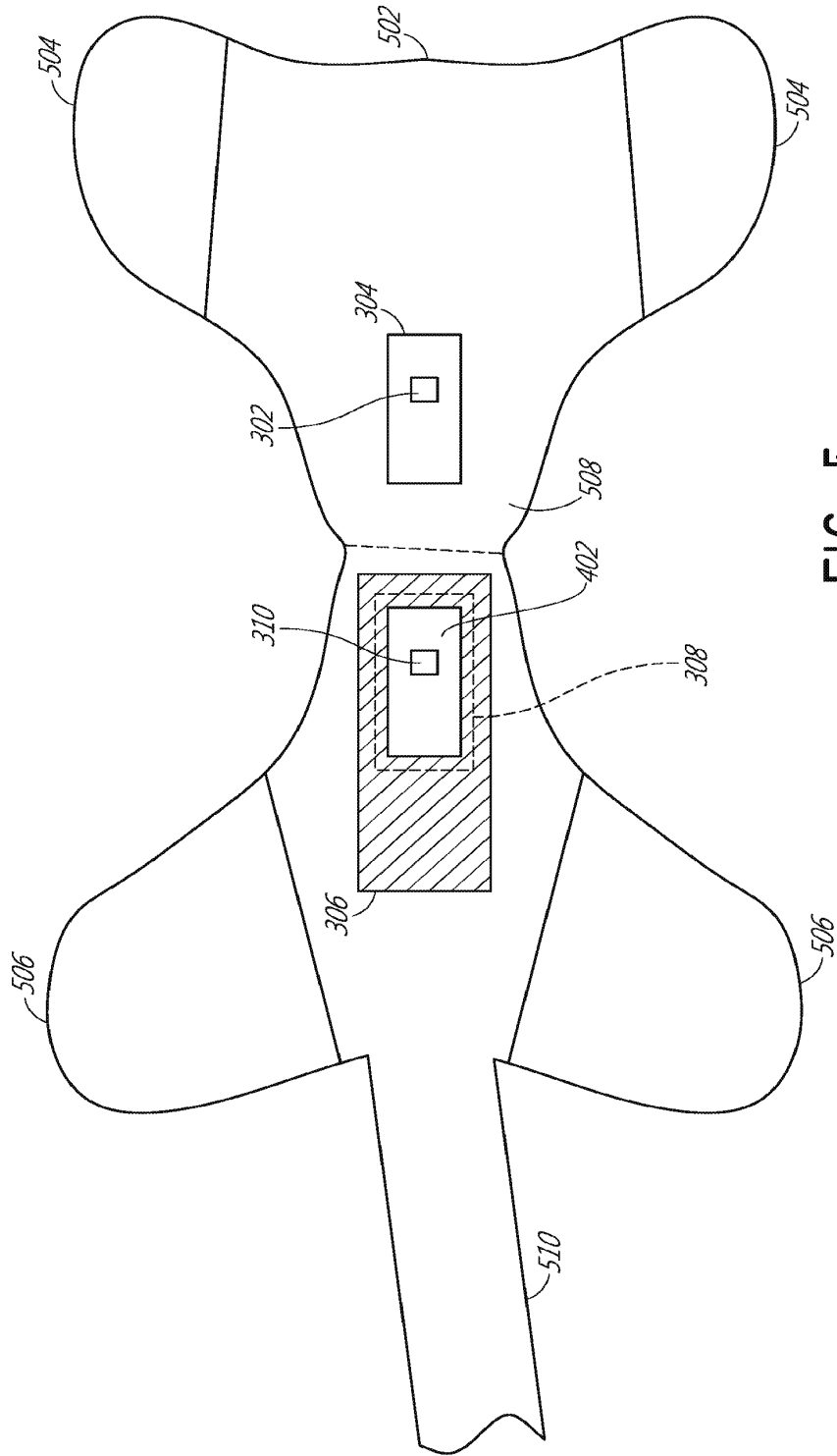

FIG. 5

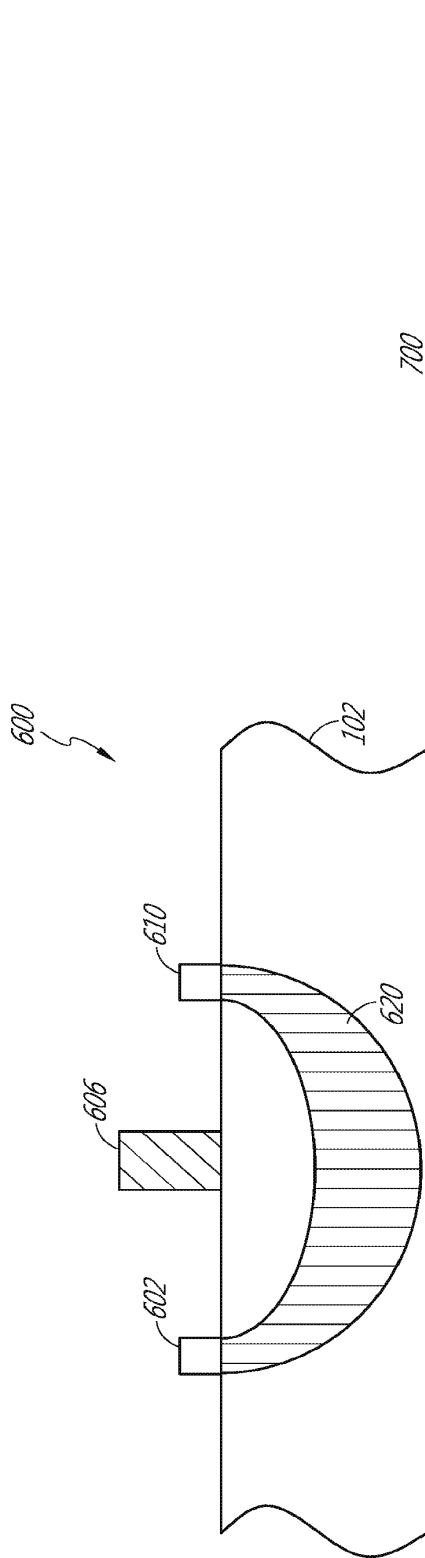

FIG. 6
(PRIOR ART)

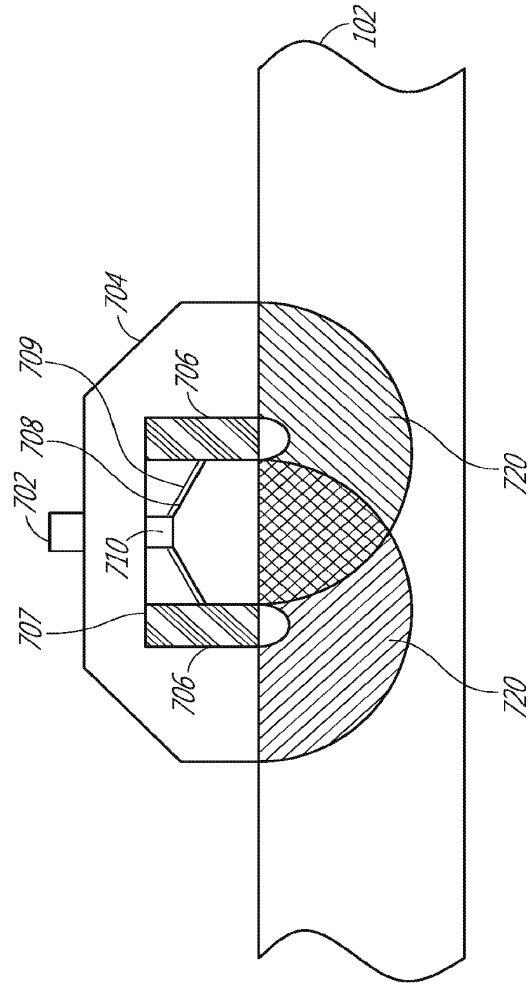

FIG. 7A

6/7

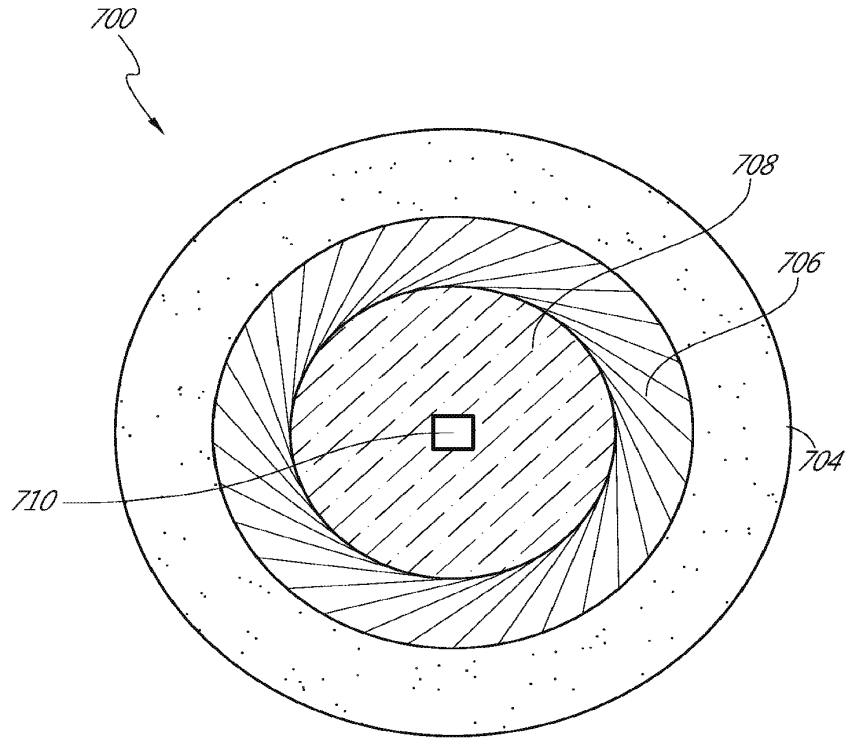

FIG. 7B

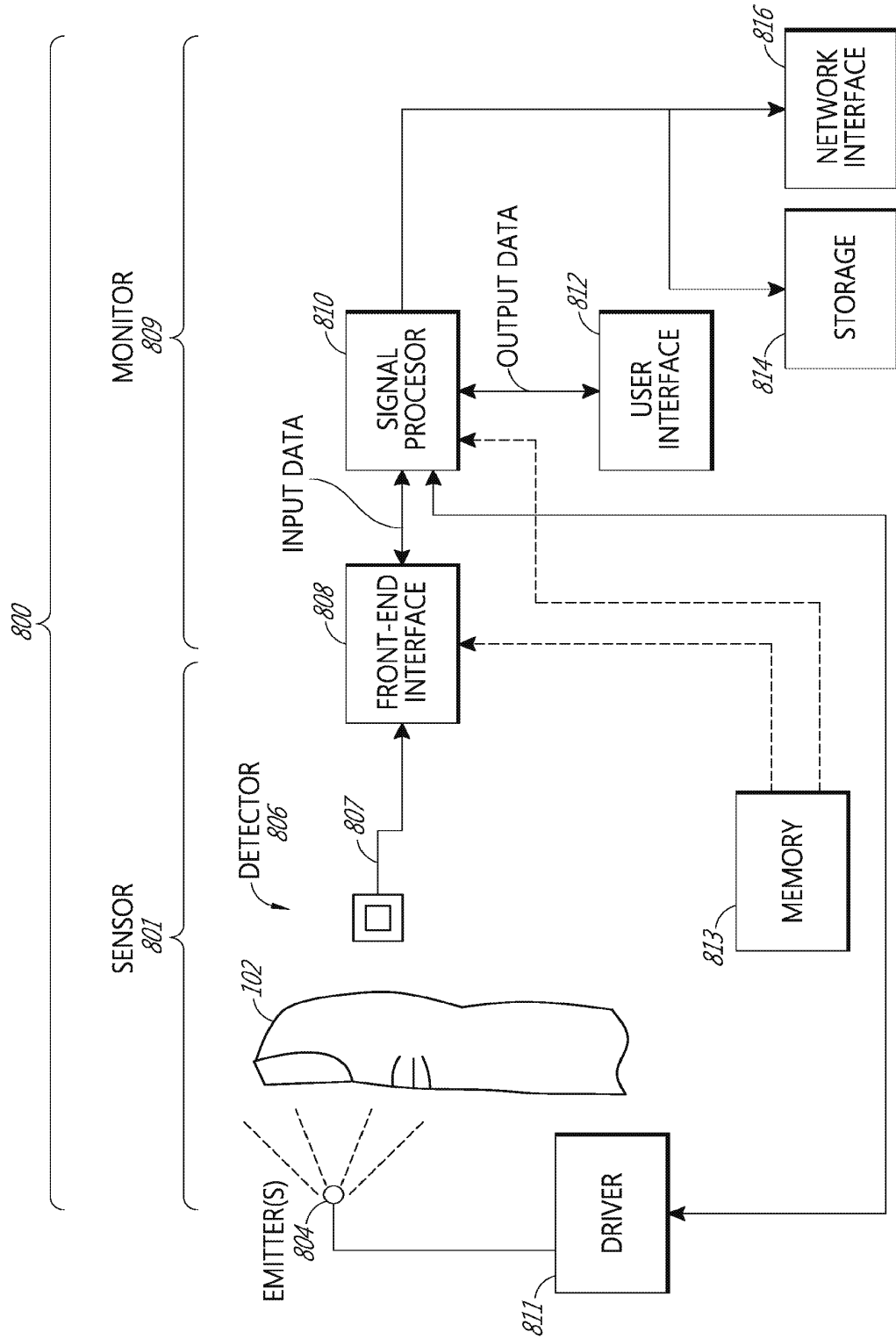

FIG. 8



UNITED STATES PATENT AND TRADEMARK OFFICE

UNITED STATES DEPARTMENT OF COMMERCE
 United States Patent and Trademark Office
 Address: COMMISSIONER FOR PATENTS
 P.O. Box 1450
 Alexandria, Virginia 22313-1450
 www.uspto.gov

APPLICATION NUMBER	FILING OR 371(C) DATE	FIRST NAMED APPLICANT	ATTY. DOCKET NO./TITLE
15/195,199	06/28/2016	Ammar Al-Ali	MASIMO.1007A

CONFIRMATION NO. 3453

INFORMAL NOTICE



64735
 KNOBBE, MARTENS, OLSON & BEAR, LLP
 2040 MAIN STREET
 FOURTEENTH FLOOR
 IRVINE, CA 92614

Date Mailed: 07/14/2016

INFORMATIONAL NOTICE TO APPLICANT

Applicant is notified that the above-identified application contains the deficiencies noted below. No period for reply is set forth in this notice for correction of these deficiencies. However, if a deficiency relates to the inventor's oath or declaration, the applicant must file an oath or declaration in compliance with 37 CFR 1.63, or a substitute statement in compliance with 37 CFR 1.64, executed by or with respect to each actual inventor no later than the expiration of the time period set in the "Notice of Allowability" to avoid abandonment. See 37 CFR 1.53(f).

The item(s) indicated below are also required and should be submitted with any reply to this notice to avoid further processing delays.

- A properly executed inventor's oath or declaration has not been received for the following inventor(s):
 Ammar Al-Ali
 Stephen Scruggs

Questions about the contents of this notice and the requirements it sets forth should be directed to the Office of Data Management, Application Assistance Unit, at (571) 272-4000 or (571) 272-4200 or 1-888-786-0101.

/ngfissha/

PATENT APPLICATION FEE DETERMINATION RECORD						Application or Docket Number 15/195,199				
Substitute for Form PTO-875										
APPLICATION AS FILED - PART I										
		(Column 1)	(Column 2)		SMALL ENTITY		OR	OTHER THAN SMALL ENTITY		
FOR	NUMBER FILED		NUMBER EXTRA	RATE(\$)	FEE(\$)		RATE(\$)	FEE(\$)		
BASIC FEE <small>(37 CFR 1.16(a), (b), or (c))</small>	N/A		N/A	N/A			N/A	280		
SEARCH FEE <small>(37 CFR 1.16(k), (l), or (m))</small>	N/A		N/A	N/A			N/A	600		
EXAMINATION FEE <small>(37 CFR 1.16(o), (p), or (q))</small>	N/A		N/A	N/A			N/A	720		
TOTAL CLAIMS <small>(37 CFR 1.16(i))</small>	36	minus 20 = *	16				x 80 =	1280		
INDEPENDENT CLAIMS <small>(37 CFR 1.16(h))</small>	4	minus 3 = *	1				x 420 =	420		
APPLICATION SIZE FEE <small>(37 CFR 1.16(s))</small>	If the specification and drawings exceed 100 sheets of paper, the application size fee due is \$310 (\$155 for small entity) for each additional 50 sheets or fraction thereof. See 35 U.S.C. 41(a)(1)(G) and 37 CFR 1.16(s).							0.00		
MULTIPLE DEPENDENT CLAIM PRESENT <small>(37 CFR 1.16(j))</small>								0.00		
* If the difference in column 1 is less than zero, enter "0" in column 2.				TOTAL			TOTAL	3300		
APPLICATION AS AMENDED - PART II										
		(Column 1)	(Column 2)	(Column 3)	SMALL ENTITY		OR	OTHER THAN SMALL ENTITY		
AMENDMENT A	CLAIMS REMAINING AFTER AMENDMENT		HIGHEST NUMBER PREVIOUSLY PAID FOR	PRESENT EXTRA	RATE(\$)	ADDITIONAL FEE(\$)		RATE(\$)	ADDITIONAL FEE(\$)	
	Total <small>(37 CFR 1.16(i))</small>	*	Minus	**	=			x	=	
	Independent <small>(37 CFR 1.16(h))</small>	*	Minus	***	=			x	=	
	Application Size Fee <small>(37 CFR 1.16(s))</small>									
	FIRST PRESENTATION OF MULTIPLE DEPENDENT CLAIM <small>(37 CFR 1.16(j))</small>									
				TOTAL ADD'L FEE			TOTAL ADD'L FEE			
AMENDMENT B	CLAIMS REMAINING AFTER AMENDMENT		HIGHEST NUMBER PREVIOUSLY PAID FOR	PRESENT EXTRA	RATE(\$)	ADDITIONAL FEE(\$)		RATE(\$)	ADDITIONAL FEE(\$)	
	Total <small>(37 CFR 1.16(i))</small>	*	Minus	**	=			x	=	
	Independent <small>(37 CFR 1.16(h))</small>	*	Minus	***	=			x	=	
	Application Size Fee <small>(37 CFR 1.16(s))</small>									
	FIRST PRESENTATION OF MULTIPLE DEPENDENT CLAIM <small>(37 CFR 1.16(j))</small>									
				TOTAL ADD'L FEE			TOTAL ADD'L FEE			
* If the entry in column 1 is less than the entry in column 2, write "0" in column 3.										
** If the "Highest Number Previously Paid For" IN THIS SPACE is less than 20, enter "20".										
*** If the "Highest Number Previously Paid For" IN THIS SPACE is less than 3, enter "3".										
The "Highest Number Previously Paid For" (Total or Independent) is the highest found in the appropriate box in column 1.										



UNITED STATES PATENT AND TRADEMARK OFFICE

UNITED STATES DEPARTMENT OF COMMERCE
 United States Patent and Trademark Office
 Address: COMMISSIONER FOR PATENTS
 P.O. Box 1450
 Alexandria, Virginia 22313-1450
 www.uspto.gov

APPLICATION NUMBER	FILING or 371(c) DATE	GRP ART UNIT	FIL FEE REC'D	ATTY. DOCKET NO	TOT CLAIMS	IND CLAIMS
15/195,199	06/28/2016	3777	3440	MASIMO.1007A	36	4

CONFIRMATION NO. 3453

FILING RECEIPT

64735
 KNOBBE, MARTENS, OLSON & BEAR, LLP
 2040 MAIN STREET
 FOURTEENTH FLOOR
 IRVINE, CA 92614



Date Mailed: 07/14/2016

Receipt is acknowledged of this non-provisional patent application. The application will be taken up for examination in due course. Applicant will be notified as to the results of the examination. Any correspondence concerning the application must include the following identification information: the U.S. APPLICATION NUMBER, FILING DATE, NAME OF APPLICANT, and TITLE OF INVENTION. Fees transmitted by check or draft are subject to collection. Please verify the accuracy of the data presented on this receipt. **If an error is noted on this Filing Receipt, please submit a written request for a Filing Receipt Correction. Please provide a copy of this Filing Receipt with the changes noted thereon. If you received a "Notice to File Missing Parts" for this application, please submit any corrections to this Filing Receipt with your reply to the Notice. When the USPTO processes the reply to the Notice, the USPTO will generate another Filing Receipt incorporating the requested corrections**

Inventor(s)

Ammar Al-Ali, San Juan Capistrano, CA;
 Stephen Scruggs, Newport Beach, CA;

Applicant(s)

MASIMO CORPORATION, Irvine, CA;

Power of Attorney: The patent practitioners associated with Customer Number 64735

Domestic Priority data as claimed by applicant

This appln claims benefit of 62/188,430 07/02/2015

Foreign Applications for which priority is claimed (You may be eligible to benefit from the **Patent Prosecution Highway** program at the USPTO. Please see <http://www.uspto.gov> for more information.) - None.

Foreign application information must be provided in an Application Data Sheet in order to constitute a claim to foreign priority. See 37 CFR 1.55 and 1.76.

Permission to Access Application via Priority Document Exchange: Yes

Permission to Access Search Results: Yes

Applicant may provide or rescind an authorization for access using Form PTO/SB/39 or Form PTO/SB/69 as appropriate.

If Required, Foreign Filing License Granted: 07/12/2016

The country code and number of your priority application, to be used for filing abroad under the Paris Convention, is **US 15/195,199**

Projected Publication Date: 01/05/2017

Non-Publication Request: No

Early Publication Request: No
Title

ADVANCED PULSE OXIMETRY SENSOR

Preliminary Class

600

Statement under 37 CFR 1.55 or 1.78 for AIA (First Inventor to File) Transition Applications: No

PROTECTING YOUR INVENTION OUTSIDE THE UNITED STATES

Since the rights granted by a U.S. patent extend only throughout the territory of the United States and have no effect in a foreign country, an inventor who wishes patent protection in another country must apply for a patent in a specific country or in regional patent offices. Applicants may wish to consider the filing of an international application under the Patent Cooperation Treaty (PCT). An international (PCT) application generally has the same effect as a regular national patent application in each PCT-member country. The PCT process **simplifies** the filing of patent applications on the same invention in member countries, but **does not result** in a grant of "an international patent" and does not eliminate the need of applicants to file additional documents and fees in countries where patent protection is desired.

Almost every country has its own patent law, and a person desiring a patent in a particular country must make an application for patent in that country in accordance with its particular laws. Since the laws of many countries differ in various respects from the patent law of the United States, applicants are advised to seek guidance from specific foreign countries to ensure that patent rights are not lost prematurely.

Applicants also are advised that in the case of inventions made in the United States, the Director of the USPTO must issue a license before applicants can apply for a patent in a foreign country. The filing of a U.S. patent application serves as a request for a foreign filing license. The application's filing receipt contains further information and guidance as to the status of applicant's license for foreign filing.

Applicants may wish to consult the USPTO booklet, "General Information Concerning Patents" (specifically, the section entitled "Treaties and Foreign Patents") for more information on timeframes and deadlines for filing foreign patent applications. The guide is available either by contacting the USPTO Contact Center at 800-786-9199, or it can be viewed on the USPTO website at <http://www.uspto.gov/web/offices/pac/doc/general/index.html>.

For information on preventing theft of your intellectual property (patents, trademarks and copyrights), you may wish to consult the U.S. Government website, <http://www.stopfakes.gov>. Part of a Department of Commerce initiative, this website includes self-help "toolkits" giving innovators guidance on how to protect intellectual property in specific countries such as China, Korea and Mexico. For questions regarding patent enforcement issues, applicants may call the U.S. Government hotline at 1-866-999-HALT (1-866-999-4258).

**LICENSE FOR FOREIGN FILING UNDER
Title 35, United States Code, Section 184
Title 37, Code of Federal Regulations, 5.11 & 5.15**

GRANTED

The applicant has been granted a license under 35 U.S.C. 184, if the phrase "IF REQUIRED, FOREIGN FILING LICENSE GRANTED" followed by a date appears on this form. Such licenses are issued in all applications where the conditions for issuance of a license have been met, regardless of whether or not a license may be required as set forth in 37 CFR 5.15. The scope and limitations of this license are set forth in 37 CFR 5.15(a) unless an earlier license has been issued under 37 CFR 5.15(b). The license is subject to revocation upon written notification. The date indicated is the effective date of the license, unless an earlier license of similar scope has been granted under 37 CFR 5.13 or 5.14.

This license is to be retained by the licensee and may be used at any time on or after the effective date thereof unless it is revoked. This license is automatically transferred to any related applications(s) filed under 37 CFR 1.53(d). This license is not retroactive.

The grant of a license does not in any way lessen the responsibility of a licensee for the security of the subject matter as imposed by any Government contract or the provisions of existing laws relating to espionage and the national security or the export of technical data. Licensees should apprise themselves of current regulations especially with respect to certain countries, of other agencies, particularly the Office of Defense Trade Controls, Department of State (with respect to Arms, Munitions and Implements of War (22 CFR 121-128)); the Bureau of Industry and Security, Department of Commerce (15 CFR parts 730-774); the Office of Foreign Assets Control, Department of Treasury (31 CFR Parts 500+) and the Department of Energy.

NOT GRANTED

No license under 35 U.S.C. 184 has been granted at this time, if the phrase "IF REQUIRED, FOREIGN FILING LICENSE GRANTED" DOES NOT appear on this form. Applicant may still petition for a license under 37 CFR 5.12, if a license is desired before the expiration of 6 months from the filing date of the application. If 6 months has lapsed from the filing date of this application and the licensee has not received any indication of a secrecy order under 35 U.S.C. 181, the licensee may foreign file the application pursuant to 37 CFR 5.15(b).

SelectUSA

The United States represents the largest, most dynamic marketplace in the world and is an unparalleled location for business investment, innovation, and commercialization of new technologies. The U.S. offers tremendous resources and advantages for those who invest and manufacture goods here. Through SelectUSA, our nation works to promote and facilitate business investment. SelectUSA provides information assistance to the international investor community; serves as an ombudsman for existing and potential investors; advocates on behalf of U.S. cities, states, and regions competing for global investment; and counsels U.S. economic development organizations on investment attraction best practices. To learn more about why the United States is the best country in the world to develop technology, manufacture products, deliver services, and grow your business, visit <http://www.SelectUSA.gov> or call +1-202-482-6800.

MASIMO.1007A

PATENT

IN THE UNITED STATES PATENT AND TRADEMARK OFFICE

First Inventor	:	Ammar Al-Ali
App. No.	:	15/195199
Filed	:	June 28, 2016
For	:	ADVANCED PULSE OXIMETRY SENSOR
Examiner	:	Unknown
Art Unit	:	3777
Conf. No.	:	3453

PRELIMINARY AMENDMENT**Mail Stop Amendment**

Commissioner for Patents
P.O. Box 1450
Alexandria, VA 22313-1450

Dear Sir:

Prior to examination of the above-identified application, please enter the amendments set forth herein.

Amendments to the Specification begin on page 2 of this paper.

Remarks/Arguments begin on page 4 of this paper.

Application No.: 15/195199
Filing Date: June 28, 2016

AMENDMENTS TO THE SPECIFICATION

Please amend the originally filed specification as set forth below.

Please amend Paragraph [0020] as follows:

[0020] FIG. 1 illustrates a conventional approach to two-dimensional pulse oximetry in which the emitter is configured to emit optical radiation as a point optical source.

Please amend Paragraph [0021] as follows:

[0021] FIG. 2 illustrates the disclosed three-dimensional approach to pulse oximetry in which the emitted light irradiates a substantially larger volume of tissue as compared to the point source approach described with respect to ~~FIG. 2A~~FIG. 1.

Please amend Paragraph [0022] as follows:

[0022] FIG. 3 illustrates schematically a side view of a three-dimensional pulse oximetry sensor according to an embodiment of the present disclosure.

Please amend Paragraph [0023] as follows:

[0023] FIG. 4A is a top view of a portion of a three-dimensional pulse oximetry sensor according to an embodiment of the present disclosure.

Please amend Paragraph [0024] as follows:

[0024] FIG. 4B illustrates the top view of a portion of the three-dimensional pulse oximetry sensor shown in FIG. 4A, with the addition of a tissue measurement site in operational position.

Please amend Paragraph [0025] as follows:

[0025] FIG. 5 illustrates a top view of a three-dimensional pulse oximetry sensor according to an embodiment of the present disclosure.

Please amend Paragraph [0026] as follows:

-2-

Application No.: 15/195199
Filing Date: June 28, 2016

[0026] FIG. 6 illustrates a conventional [[2D]]two-dimensional approach to reflective pulse oximetry in which the emitter is configured to emit optical radiation as a point optical source.

Please amend Paragraph [0027] as follows:

[0027] FIG. 7A is a simplified schematic side view illustration of a reflective [[3D]]three-dimensional pulse oximetry sensor according to an embodiment of the present disclosure.

Please amend Paragraph [0028] as follows:

[0028] FIG. 7B is a simplified schematic top view illustration of the [[3D]]three-dimensional reflective pulse oximetry sensor of FIG. 7A.

Marked-Up Specification

MASIMO.1007A

PATENT

ADVANCED PULSE OXIMETRY SENSOR

INCORPORATION BY REFERENCE TO ANY PRIORITY APPLICATIONS

[0001] This present application claims priority benefit under 35 U.S.C. § 119(e) from U.S. Provisional Application No. 62/188,430, filed July 2, 2015, entitled “Advanced Pulse Oximetry Sensor,” which is incorporated by reference herein. Any and all applications for which a foreign or domestic priority claim is identified in the Application Data Sheet as filed with the present application are hereby incorporated by reference under 37 CFR 1.57.

FIELD OF THE DISCLOSURE

[0002] The present disclosure relates to the field of non-invasive optical-based physiological monitoring sensors, and more particularly to systems, devices and methods for improving the non-invasive measurement accuracy of oxygen saturation, among other physiological parameters.

BACKGROUND

[0003] Spectroscopy is a common technique for measuring the concentration of organic and some inorganic constituents of a solution. The theoretical basis of this technique is the Beer-Lambert law, which states that the concentration c_i of an absorbent in solution can be determined by the intensity of light transmitted through the solution, knowing the pathlength d_λ , the intensity of the incident light $I_{o,\lambda}$, and the extinction coefficient $\varepsilon_{i,\lambda}$ at a particular wavelength λ .

[0004] In generalized form, the Beer-Lambert law is expressed as:

$$I_\lambda = I_{o,\lambda} e^{-d_\lambda \cdot \mu_{a,\lambda}} \quad (1)$$

$$\mu_{a,\lambda} = \sum_{i=1}^n \varepsilon_{i,\lambda} \cdot c_i \quad (2)$$

where $\mu_{a,\lambda}$ is the bulk absorption coefficient and represents the probability of absorption per unit length. The minimum number of discrete wavelengths that are

Marked-Up Specification

required to solve equations 1 and 2 is the number of significant absorbers that are present in the solution.

[0005] A practical application of this technique is pulse oximetry, which utilizes a noninvasive sensor to measure oxygen saturation and pulse rate, among other physiological parameters. Pulse oximetry relies on a sensor attached externally to the patient to output signals indicative of various physiological parameters, such as a patient's blood constituents and/or analytes, including for example a percent value for arterial oxygen saturation, among other physiological parameters. The sensor has an emitter that transmits optical radiation of one or more wavelengths into a tissue site and a detector that responds to the intensity of the optical radiation after absorption by pulsatile arterial blood flowing within the tissue site. Based upon this response, a processor determines the relative concentrations of oxygenated hemoglobin (HbO₂) and deoxygenated hemoglobin (Hb) in the blood so as to derive oxygen saturation, which can provide early detection of potentially hazardous decreases in a patient's oxygen supply.

[0006] A pulse oximetry system generally includes a patient monitor, a communications medium such as a cable, and/or a physiological sensor having one or more light emitters and a detector, such as one or more light-emitting diodes (LEDs) and a photodetector. The sensor is attached to a tissue site, such as a finger, toe, earlobe, nose, hand, foot, or other site having pulsatile blood flow which can be penetrated by light from the one or more emitters. The detector is responsive to the emitted light after attenuation or reflection by pulsatile blood flowing in the tissue site. The detector outputs a detector signal to the monitor over the communication medium. The monitor processes the signal to provide a numerical readout of physiological parameters such as oxygen saturation (SpO₂) and/or pulse rate. A pulse oximetry sensor is described in U.S. Patent No. 6,088,607 entitled *Low Noise Optical Probe*; pulse oximetry signal processing is described in U.S. Patent Nos. 6,650,917 and 6,699,194 entitled *Signal Processing Apparatus* and *Signal Processing Apparatus and Method*, respectively; a pulse oximeter monitor is described in U.S. Patent No. 6,584,336 entitled *Universal/Upgrading Pulse*

Marked-Up Specification

Oximeter; all of which are assigned to Masimo Corporation, Irvine, CA, and each is incorporated by reference herein in its entirety.

[0007] There are many sources of measurement error introduced to pulse oximetry systems. Some such sources of error include the pulse oximetry system's electronic components, including emitters and detectors, as well as chemical and structural physiological differences between patients. Another source of measurement error is the effect of multiple scattering of photons as the photons pass through the patient's tissue (arterial blood) and arrive at the sensor's light detector.

SUMMARY

[0008] This disclosure describes embodiments of non-invasive methods, devices, and systems for measuring blood constituents, analytes, and/or substances such as, by way of non-limiting example, oxygen, carboxyhemoglobin, methemoglobin, total hemoglobin, glucose, proteins, lipids, a percentage thereof (*e.g.*, saturation), pulse rate, perfusion index, oxygen content, total hemoglobin, Oxygen Reserve Index™ (ORI™) or for measuring many other physiologically relevant patient characteristics. These characteristics can relate to, for example, pulse rate, hydration, trending information and analysis, and the like.

[0009] In an embodiment, an optical physiological measurement system includes an emitter configured to emit light of one or more wavelengths. The system also includes a diffuser configured to receive the emitted light, to spread the received light, and to emit the spread light over a larger tissue area than would otherwise be penetrated by the emitter directly emitting light at a tissue measurement site. The tissue measurement site can include, such as, for example, a finger, a wrist, or the like. The system further includes a concentrator configured to receive the spread light after it has been attenuated by or reflected from the tissue measurement site. The concentrator is also configured to collect and concentrate the received light and to emit the concentrated light to a detector. The detector is configured to detect the concentrated light and to transmit a signal indicative of the detected light. The system also includes a processor configured to receive the

Marked-Up Specification

transmitted signal indicative of the detected light and to determine, based on an amount of absorption, an analyte of interest, such as, for example, arterial oxygen saturation or other parameter, in the tissue measurement site.

[0010] In certain embodiments of the present disclosure, the diffuser comprises glass, ground glass, glass beads, opal glass, or a microlens-based, band-limited, engineered diffuser that can deliver efficient and uniform illumination. In some embodiments the diffuser is further configured to define a surface area shape by which the emitted spread light is distributed onto a surface of the tissue measurement site. The defined surface area shape can include, by way of non-limiting example, a shape that is substantially rectangular, square, circular, oval, or annular, among others.

[0011] According to some embodiments, the optical physiological measurement system includes an optical filter having a light-absorbing surface that faces the tissue measurement site. The optical filter also has an opening that is configured to allow the spread light, after being attenuated by the tissue measurement site, to be received by the concentrator. In an embodiment, the opening has dimensions, wherein the dimensions of the opening are similar to the defined surface area shape by which the emitted spread light is distributed onto the surface of the tissue measurement site. In an embodiment, the opening has dimensions that are larger than the defined surface area shape by which the emitted spread light is distributed onto the surface of the tissue measurement site. In other embodiments, the dimensions of the opening in the optical filter are not the same as the diffuser opening, but the dimensions are larger than the detector package.

[0012] In other embodiments of the present disclosure, the concentrator comprises glass, ground glass, glass beads, opal glass, or a compound parabolic concentrator. In some embodiments the concentrator comprises a cylindrical structure having a truncated circular conical structure on top. The truncated section is adjacent the detector. The light concentrator is structured to receive the emitted optical radiation, after reflection by the tissue measurement site, and to direct the reflected light to the detector.

Marked-Up Specification

[0013] In accordance with certain embodiments of the present disclosure, the processor is configured to determine an average level of the light detected by the detector. The average level of light is used to determine a physiological parameter in the tissue measurement site.

[0014] According to another embodiment, a method to determine a constituent or analyte in a patient's blood is disclosed. The method includes emitting, from an emitter, light of at least one wavelength; spreading, with a diffuser, the emitted light and emitting the spread light from the diffuser to a tissue measurement site; receiving, by a concentrator, the spread light after the spread light has been attenuated by the tissue measurement site; concentrating, by the concentrator, the received light and emitting the concentrated light from the concentrator to a detector; detecting, with the detector, the emitted concentrated light; transmitting, from the detector, a signal responsive to the detected light; receiving, by a processor, the transmitted signal responsive to the detected light; and processing, by the processor, the received signal responsive to the detected light to determine a physiological parameter.

[0015] In some embodiments, the method to determine a constituent or analyte in a patient's blood includes filtering, with a light-absorbing detector filter, scattered portions of the emitted spread light. According to an embodiment, the light-absorbing detector filter is substantially rectangular in shape and has outer dimensions in the range of approximately 1-5 cm in width and approximately 2-8 cm in length, and has an opening through which emitted light may pass, the opening having dimensions in the range of approximately 0.25-3 cm in width and approximately 1-7 cm in length. In another embodiment, the light-absorbing detector filter is substantially square in shape and has outer dimensions in the range of approximately 0.25-10 cm², and has an opening through which emitted light may pass, the opening having dimensions in the range of approximately 0.1-8cm². In yet another embodiment, the light-absorbing detector filter is substantially rectangular in shape and has outer dimensions of approximately 3 cm in width and approximately 6 cm in length, and has an opening through which emitted light may pass, the

Marked-Up Specification

opening having dimensions of approximately 1.5 cm in width and approximately 4 cm in length.

[0016] In still other embodiments of the method to determine a constituent or analyte in a patient's blood, spreading, with a diffuser, the emitted light and emitting the spread light from the diffuser to a tissue measurement site is performed by at least one of a glass diffuser, a ground glass diffuser, a glass bead diffuser, an opal glass diffuser, and an engineered diffuser. In some embodiments the emitted spread light is emitted with a substantially uniform intensity profile. And in some embodiments, emitting the spread light from the diffuser to the tissue measurement site includes spreading the emitted light so as to define a surface area shape by which the emitted spread light is distributed onto a surface of the tissue measurement site.

[0017] According to yet another embodiment, a pulse oximeter is disclosed. The pulse oximeter includes an emitter configured to emit light at one or more wavelengths. The pulse oximeter also includes a diffuser configured to receive the emitted light, to spread the received light, and to emit the spread light directed at a tissue measurement site. The pulse oximeter also includes a detector configured to detect the emitted spread light after being attenuated by or reflected from the tissue measurement site and to transmit a signal indicative of the detected light. The pulse oximeter also includes a processor configured to receive the transmitted signal and to process the received signal to determine an average absorbance of a blood constituent or analyte in the tissue measurement site over a larger measurement site area than can be performed with a point light source or point detector. In some embodiments, the diffuser is further configured to define a surface area shape by which the emitted spread light is distributed onto a surface of the tissue measurement site, and the detector is further configured to have a detection area corresponding to the defined surface area shape by which the emitted spread light is distributed onto the surface of the tissue measurement site. According to some embodiments, the detector comprises an array of detectors configured to cover the detection area. In still other embodiments, the processor is further configured to determine an average of the detected light.

Marked-Up Specification

[0018] For purposes of summarizing, certain aspects, advantages and novel features of the disclosure have been described herein. It is to be understood that not necessarily all such advantages can be achieved in accordance with any particular embodiment of the systems, devices and/or methods disclosed herein. Thus, the subject matter of the disclosure herein can be embodied or carried out in a manner that achieves or optimizes one advantage or group of advantages as taught herein without necessarily achieving other advantages as can be taught or suggested herein.

BRIEF DESCRIPTION OF THE DRAWINGS

[0019] Throughout the drawings, reference numbers can be re-used to indicate correspondence between referenced elements. The drawings are provided to illustrate embodiments of the disclosure described herein and not to limit the scope thereof.

[0020] FIG. 1 illustrates a conventional approach to two-dimensional pulse oximetry in which the emitter is configured to emit optical radiation as a point optical source.

[0021] FIG. 2 illustrates the disclosed three-dimensional approach to pulse oximetry in which the emitted light irradiates a substantially larger volume of tissue as compared to the point source approach described with respect to FIG. 1.

[0022] FIG. 3 illustrates schematically a side view of a three-dimensional pulse oximetry sensor according to an embodiment of the present disclosure.

[0023] FIG. 4A is a top view of a portion of a three-dimensional pulse oximetry sensor according to an embodiment of the present disclosure.

[0024] FIG. 4B illustrates the top view of a portion of the three-dimensional pulse oximetry sensor shown in FIG. 4A, with the addition of a tissue measurement site in operational position.

[0025] FIG. 5 illustrates a top view of a three-dimensional pulse oximetry sensor according to an embodiment of the present disclosure.

Marked-Up Specification

[0026] FIG. 6 illustrates a conventional [[2D]]two-dimensional approach to reflective pulse oximetry in which the emitter is configured to emit optical radiation as a point optical source.

[0027] FIG. 7A is a simplified schematic side view illustration of a reflective [[3D]]three-dimensional pulse oximetry sensor according to an embodiment of the present disclosure.

[0028] FIG. 7B is a simplified schematic top view illustration of the [[3D]]three-dimensional reflective pulse oximetry sensor of FIG. 7A.

[0029] FIG. 8 illustrates a block diagram of an example pulse oximetry system capable of noninvasively measuring one or more blood analytes in a monitored patient, according to an embodiment of the disclosure.

DETAILED DESCRIPTION

[0030] FIG. 1 illustrates schematically a conventional pulse oximetry sensor having a two-dimensional (2D) approach to pulse oximetry. As illustrated, the emitter 104 is configured to emit optical radiation as a point optical source, *i.e.*, an optical radiation source that has negligible dimensions such that it may be considered as a point. This approach is referred to herein as “two-dimensional” pulse oximetry because it applies a two-dimensional analytical model to the three-dimensional space of the tissue measurement site 102 of the patient. Point optical sources feature a defined, freely selectable, and homogeneous light beam area. Light beams emitted from LED point sources often exhibit a strong focus which can produce a usually sharply-defined and evenly-lit illuminated spot often with high intensity dynamics. Illustratively, when looking at the surface of the tissue measurement site 102 (or “sample tissue”), which in this example is a finger, a small point-like surface area of tissue 204 is irradiated by a point optical source. In some embodiments, the irradiated circular area of the point optical source is in the range between 8 and 150 microns. Illustratively, the emitted point optical source of light enters the tissue measurement site 102 as a point of light. As the light penetrates the depth of the tissue 102, it does so as a line or vector, representing a

Marked-Up Specification

two-dimensional construct within a three-dimensional structure, namely the patient's tissue 102.

[0031] Use of a point optical source is believed to reduce variability in light pathlength which would lead to more accurate oximetry measurements. However, in practice, photons do not travel in straight paths. Instead, the light particles scatter, bouncing around between various irregular objects (such as, for example, red blood cells) in the patient's blood. Accordingly, photon pathlengths vary depending on, among other things, their particular journeys through and around the tissue at the measurement site 102. This phenomenon is referred to as "multiple scattering." In a study, the effects of multiple scattering were examined by comparing the results of photon diffusion analysis with those obtained using an analysis based on the Beer-Lambert law, which neglects multiple scattering in the determination of light pathlength. The study found that that the difference between the average lengths of the paths traveled by red and infrared photons makes the oximeter's calibration curve (based on measurements obtained from normal subjects) sensitive to the total attenuation coefficients of the tissue in the two wavelength bands used for pulse oximetry, as well as to absorption by the pulsating arterial blood.

[0032] FIG. 2 illustrates schematically the disclosed systems, devices, and methods to implement three-dimensional (3D) pulse oximetry in which the emitted light irradiates a larger volume of tissue at the measurement site 102 as compared to the 2D point optical source approach described with respect to FIG. 1. In an embodiment, again looking at the surface of the tissue measurement site 102, the irradiated surface area 206 of the measurement site 102 is substantially rectangular in shape with dimensions in the range of approximately 0.25-3 cm in width and approximately 1-6 cm in length. In another embodiment, the irradiated surface area 206 of the measurement site 102 is substantially rectangular in shape and has dimensions of approximately 1.5 cm in width and approximately 2 cm in length. In another embodiment, the irradiated surface area 206 of the measurement site 102 is substantially rectangular in shape and has dimensions of approximately 0.5 cm in width and approximately 1 cm in length. In another embodiment, the irradiated surface area 206 of the measurement site 102 is substantially rectangular in shape

Marked-Up Specification

has dimensions of approximately 1 cm in width and approximately 1.5 cm in length. In yet another embodiment, the irradiated surface area 206 of the measurement site 102 is substantially square in shape and has dimensions in a range of approximately 0.25-9 cm². In certain embodiments, the irradiated surface area 206 of the measurement site 102 is within a range of approximately 0.5-2 cm in width, and approximately 1-4 cm in length. Of course a skilled artisan will appreciate that many other shapes and dimensions of irradiated surface area 206 can be used. Advantageously, by irradiating the tissue measurement site 102 with a surface area 206, the presently disclosed systems, devices, and methods apply a three-dimensional analytical model to the three-dimensional structure being measured, namely, the patient's sample tissue 102.

[0033] According to the Beer-Lambert law, the amount of light absorbed by a substance is proportional to the concentration of the light-absorbing substance in the irradiated solution (*i.e.*, arterial blood). Advantageously, by irradiating a larger volume of tissue 102, a larger sample size of light attenuated (or reflected) by the tissue 102 is measured. The larger, 3D sample provides a data set that is more representative of the complete interaction of the emitted light as it passes through the patient's blood as compared to the 2D point source approach described above with respect to FIG. 1. By taking an average of the detected light, as detected over a surface area substantially larger than a single point, the disclosed pulse oximetry systems, devices, and methods will yield a more accurate measurement of the emitted light absorbed by the tissue, which will lead to a more accurate oxygen saturation measurement.

[0034] FIG. 3 illustrates schematically a side view of a pulse oximetry 3D sensor 300 according to an embodiment of the present disclosure. In the illustrated embodiment, the 3D sensor 300 irradiates the tissue measurement site 102 and detects the emitted light, after being attenuated by the tissue measurement site 102. In other embodiments, for example, as describe below with respect to FIGS. 7A and 7B, the 3D sensor 300 can be arranged to detect light that is reflected by the tissue measurement site 102. The 3D sensor 300 includes an emitter 302, a light diffuser 304, a light-absorbing detector filter 306, a light concentrator 308, and a detector

Marked-Up Specification

310. In some optional embodiments, the 3D sensor 300 further includes a reflector 305. The reflector 305 can be a metallic reflector or other type of reflector. Reflector 305 can be a coating, film, layer or other type of reflector. The reflector 305 can serve as a reflector to prevent emitted light from emitting out of a top portion of the light diffuser 304 such that light from the emitter 302 is directed in the tissue rather than escaping out of a side or top of the light diffuser 304. Additionally, the reflector 305 can prevent ambient light from entering the diffuser 304 which might ultimately cause errors within the detected light. The reflector 305 also prevent light piping that might occur if light from the detector 302 is able to escape from the light diffuser 304 and be piped around a sensor securement mechanism to detector 310 without passing through the patient's tissue 102.

[0035] The emitter 302 can serve as the source of optical radiation transmitted towards the tissue measurement site 102. The emitter 302 can include one or more sources of optical radiation, such as LEDs, laser diodes, incandescent bulbs with appropriate frequency-selective filters, combinations of the same, or the like. In an embodiment, the emitter 302 includes sets of optical sources that are capable of emitting visible and near-infrared optical radiation. In some embodiments, the emitter 302 transmits optical radiation of red and infrared wavelengths, at approximately 650 nm and approximately 940 nm, respectively. In some embodiments, the emitter 302 includes a single source optical radiation.

[0036] The light diffuser 304 receives the optical radiation emitted from the emitter 302 and spreads the optical radiation over an area, such as the area 206 depicted in FIG. 2. In some embodiments, the light diffuser 304 is a beam shaper that can homogenize the input light beam from the emitter 302, shape the output intensity profile of the received light, and define the way (*e.g.*, the shape or pattern) the emitted light is distributed to the tissue measurement site 102. Examples of materials that can be used to realize the light diffuser 304 include, without limitation, a white surface, glass, ground glass, glass beads, polytetrafluoroethylene (also known as Teflon®, opal glass, and greyed glass, to name a few. Additionally, engineered diffusers can be used to realize the diffuser 304 by providing customized light shaping with respect to intensity and distribution. Such diffusers can, for

Marked-Up Specification

example, deliver substantially uniform illumination over a specified target area (such as, for example, irradiated surface area 206) in an energy-efficient manner. Examples of engineered diffusers can include molded plastics with specific shapes, patterns or textures designed to diffuse the emitter light across the entirety of the patient's tissue surface.

[0037] Advantageously, the diffuser 304 can receive emitted light in the form of a point optical source and spread the light to fit a desired surface area on a plane defined by the surface of the tissue measurement site 102. In an embodiment, the diffuser 304 is made of ground glass which spreads the emitted light with a Gaussian intensity profile. In another embodiment the diffuser 304 includes glass beads. In some embodiments, the diffuser 304 is constructed so as to diffuse the emitted light in a Lambertian pattern. A Lambertian pattern is one in which the radiation intensity is substantially constant throughout the area of dispersion. One such diffuser 304 is made from opal glass. Opal glass is similar to ground glass, but has one surface coated with a milky white coating to diffuse light evenly. In an embodiment, the diffuser 304 is capable of distributing the emitted light on the surface of a plane (*e.g.*, the surface of the tissue measurement site 102) in a predefined geometry (*e.g.*, a rectangle, square, or circle), and with a substantially uniform intensity profile and energy distribution. In some embodiments, the efficiency, or the amount of light transmitted by the diffuser 304, is greater than 70% of the light emitted by the emitter 302. In some embodiments, the efficiency is greater than 90% of the emitted light. Other optical elements known in the art may be used for the diffuser 304.

[0038] In an embodiment, the diffuser 304 has a substantially rectangular shape having dimensions within a range of approximately 0.5-2 cm in width and approximately 1-4 centimeters in length. In another embodiment, the substantially rectangular shape of the diffuser 304 has dimensions of approximately 0.5 cm in width and approximately 1 cm in length. In another embodiment, the diffuser's 304 substantially rectangular shape has dimensions of approximately 1 cm in width and approximately 1.5 cm in length. In yet another embodiment, the diffuser 304 has a

Marked-Up Specification

substantially square shape with dimensions in the range of approximately 0.25-10 cm².

[0039] The light-absorbing detector filter 306, which is also depicted in FIG. 4A in a top view, is a planar surface having an opening 402 through which the emitted light may pass after being attenuated by the tissue measurement site 102. In the depicted embodiment, the opening 402 is rectangular-shaped, with dimensions substantially similar to the irradiated surface area 206. According to an embodiment, the light-absorbing detector filter is substantially rectangular in shape and has outer dimensions of 4 cm in width and 8 cm in length, and has an opening through which emitted light may pass, the opening having dimensions of 2 cm in width and 5 cm in length. In another embodiment, the light-absorbing detector filter is substantially rectangular in shape and has outer dimensions in the range of 1-3 cm in width and 2-8 cm in length, and has an opening through which emitted light may pass, the opening having dimensions in the range of 0.25-2 cm in width and 1-4 cm in length. In yet another embodiment, the light-absorbing detector filter is substantially rectangular in shape and has outer dimensions of 3 cm in width and 6 cm in length, and has an opening through which emitted light may pass, the opening having dimensions of 1.5 cm in width and 4 cm in length.

[0040] The top surface of the light-absorbing filter 306 (facing the tissue measurement site 102 and the emitter 302) is coated with a material that absorbs light, such as, for example, black pigment. Many other types of light-absorbing materials are well known in the art and can be used with the detector filter 306. During operation, light emitted from the emitter 302 can reflect off of the tissue measurement site 102 (or other structures within the 3D sensor 300) to neighboring portions of the 3D sensor 300. If those neighboring portions of the 3D sensor 300 possess reflective surfaces, then the light can reflect back to the tissue measurement site 102, progress through the tissue and arrive at the detector 310. Such multiple scattering can result in detecting photons whose pathlengths are considerably longer than most of the light that is detected, thereby introducing variations in pathlength which will affect the accuracy of the measurements of the pulse oximetry 3D sensor 300. Advantageously, the light-absorbing filter 306

Marked-Up Specification

reduces or eliminates the amount of emitted light that is reflected in this manner because it absorbs such reflected light, thereby stopping the chain of scattering events. In certain embodiments, the sensor-facing surfaces of other portions of the 3D sensor 300 are covered in light-absorbing material to further decrease the effect of reflective multiple scattering.

[0041] The light concentrator 308 is a structure to receive the emitted optical radiation, after attenuation by the tissue measurement site 102, to collect and concentrate the dispersed optical radiation, and to direct the collected and concentrated optical radiation to the detector 310. In an embodiment, the light concentrator 308 is made of ground glass or glass beads. In some embodiments, the light concentrator 308 includes a compound parabolic concentrator.

[0042] As described above with respect to FIG. 1, the detector 310 captures and measures light from the tissue measurement site 102. For example, the detector 310 can capture and measure light transmitted from the emitter 302 that has been attenuated by the tissue in the measurement site 102. The detector 310 can output a detector signal responsive to the light captured or measured. The detector 310 can be implemented using one or more photodiodes, phototransistors, or the like. In addition, a plurality of detectors 310 can be arranged in an array with a spatial configuration corresponding to the irradiated surface area 206 to capture the attenuated or reflected light from the tissue measurement site.

[0043] Referring to FIG. 4A, a top view of a portion of the 3D sensor 300 is provided. The light-absorbing detector filter 306 is illustrated having a top surface coated with a light-absorbing material. The light-absorbing material can be a black opaque material or coating or any other dark color or coating configured to absorb light. Additionally, a rectangular opening 402 is positioned relative to the light concentrator 308 (shown in phantom) and the detector 310 such that light may pass through the rectangular opening 402, into the light concentrator 308, and to the detector 310. FIG. 4B illustrates the top view of a portion of the 3D sensor 300 as in FIG. 4A, with the addition of the tissue measurement site 102 in operational position. Accordingly, the rectangular opening 402, the light concentrator 308 and the detector 310 are shown in phantom as being under the tissue measurement site

Marked-Up Specification

102. In FIGS. 4A and 4B, the light concentrator 308 is shown to have dimensions significantly larger than the dimensions of the rectangular opening 402. In other embodiments, the dimensions of the light concentrator 308, the rectangular opening 402, and the irradiated surface area 206 are substantially similar.

[0044] FIG. 5 illustrates a top view of a 3D pulse oximetry sensor 500 according to an embodiment of the present disclosure. The 3D sensor 500 is configured to be worn on a patient's finger 102. The 3D sensor 500 includes an adhesive substrate 502 having front flaps 504 and rear flaps 506 extending outward from a center portion 508 of the 3D sensor 500. The center portion 508 includes components of the 3D pulse oximetry sensor 300 described with respect to FIGS. 3, 4A and 4B. On the front side of the adhesive substrate 502 the emitter 302 and the light diffuser 304 are positioned. On the rear side of the adhesive substrate 502 the light-absorbent detector filter 306, the light concentrator 308 and the detector 310 are positioned. In use, the patient's finger serving as the tissue measurement site 102 is positioned over the rectangular opening 402 such that when the front portion of the adhesive substrate is folded over on top of the patient's finger 102, the emitter 302 and the light diffuser 304 are aligned with the measurement site 102, the filter 306, the light concentrator 308 and the detector 310. Once alignment is established, the front and rear flaps 504, 506 can be wrapped around the finger measurement site 102 such that the adhesive substrate 502 provides a secure contact between the patient's skin and the 3D sensor 500. Fig. 5 also illustrates an example of a sensor connector cable 510 which is used to connect the 3D sensor 500 to a monitor 809, as described with respect to FIG. 8.

[0045] FIG. 6 is a simplified schematic illustration of a conventional, 2D approach to reflective pulse oximetry in which the emitter is configured to emit optical radiation as a point optical source. Reflective pulse oximetry is a method by which the emitter and detector are located on the same side of the tissue measurement site 102. Light is emitted into a tissue measurement site 102 and attenuated. The emitted light passes into the tissue 102 and is then reflected back to the same side of the tissue measurement site 102 as the emitter. As illustrated in FIG. 6, a depicted reflective 2D pulse oximetry sensor 600 includes an emitter 602,

Marked-Up Specification

a light block 606, and a detector 610. The light block 606 is necessary because the emitter 602 and the detector 610 are located on the same side of the tissue measurement site 102. Accordingly, the light block 606 prevents incident emitter light, which did not enter the tissue measurement site 102, from arriving at the detector 610. The depicted 2D pulse oximetry sensor 600 is configured to emit light as a point source. As depicted in FIG. 6, a simplified illustration of the light path 620 of the emitted light from the emitter 602, through the tissue measurement site 102, and to the detector 610 is provided. Notably, a point source of light is emitted, and a point source of light is detected. As discussed above with respect to FIG. 1, use of a point optical source can result in substantial measurement error due to pathlength variability resulting from the multiple scatter phenomenon. The sample space provided by a 2D point optical emitter source is not large enough to account for pathlength variability, which will skew measurement results.

[0046] FIGS. 7A and 7B are simplified schematic side and top views, respectively, of a 3D reflective pulse oximetry sensor 700 according to an embodiment of the present disclosure. In the illustrated embodiment, the 3D sensor 700 irradiates the tissue measurement site 102 and detects the emitted light that is reflected by the tissue measurement site 102. The 3D sensor 700 can be placed on a portion of the patient's body that has relatively flat surface, such as, for example a wrist, because the emitter 702 and detector 710 are on located the same side of the tissue measurement site 102. The 3D sensor 700 includes an emitter 702, a light diffuser 704, a light block 706, a light concentrator 708, and a detector 710.

[0047] As previously described, the emitter 702 can serve as the source of optical radiation transmitted towards the tissue measurement site 102. The emitter 702 can include one or more sources of optical radiation. Such sources of optical radiation can include LEDs, laser diodes, incandescent bulbs with appropriate frequency-selective filters, combinations of the same, or the like. In an embodiment, the emitter 702 includes sets of optical sources that are capable of emitting visible and near-infrared optical radiation. In some embodiments, the emitter 702 transmits optical radiation of red and infrared wavelengths, at approximately 650 nm and

Marked-Up Specification

approximately 940 nm, respectively. In some embodiments, the emitter 702 includes a single source of optical radiation.

[0048] The light diffuser 704 receives the optical radiation emitted from the emitter 302 and homogenously spreads the optical radiation over a wide, donut-shaped area, such as the area outlined by the light diffuser 704 as depicted in FIG. 7B. Advantageously, the diffuser 704 can receive emitted light in the form of a 2D point optical source (or any other form) and spread the light to fit the desired surface area on a plane defined by the surface of the tissue measurement site 102. In an embodiment, the diffuser 704 is made of ground glass or glass beads. A skilled artisan will understand that many other materials can be used to make the light diffuser 704.

[0049] The light blocker 706 includes an annular ring having a cover portion 707 sized and shaped to form a light isolation chamber for the light concentrator 708 and the detector 710. (For purposes of illustration, the light block cover 707 is not illustrated in FIG. 7B.) The light blocker 706 and the cover 707 can be made of any material that optically isolates the light concentrator 708 and the detector 710. The light isolation chamber formed by the light blocker 706 and cover 707 ensures that the only light detected by the detector 710 is light that is reflected from the tissue measurement site.

[0050] The light concentrator 708 is a cylindrical structure with a truncated circular conical structure on top, the truncated section of which is adjacent the detector 710. The light concentrator 708 is structured to receive the emitted optical radiation, after reflection by the tissue measurement site 102, and to direct the reflected light to the detector 710. In an embodiment, the light concentrator 708 is made of ground glass or glass beads. In some embodiments, the light concentrator 708 includes a compound parabolic concentrator.

[0051] As previously described, the detector 710 captures and measures light from the tissue measurement site 102. For example, the detector 710 can capture and measure light transmitted from the emitter 702 that has been reflected from the tissue in the measurement site 102. The detector 710 can output a detector signal responsive to the light captured or measured. The detector 710 can be

Marked-Up Specification

implemented using one or more photodiodes, phototransistors, or the like. In addition, a plurality of detectors 710 can be arranged in an array with a spatial configuration corresponding to the irradiated surface area depicted in FIG. 7B by the light concentrator 708 to capture the reflected light from the tissue measurement site.

[0052] Advantageously, the light path 720 illustrated in FIG. 7A depicts a substantial sample of reflected light that enter the light isolation chamber formed by the light blocker 706 and cover 707. As previously discussed, the large sample of reflected light (as compared to the reflected light collected using the 2D point optical source approach) provides the opportunity to take an average of the detected light, to derive a more accurate measurement of the emitted light absorbed by the tissue, which will lead to a more accurate oxygen saturation measurement.

[0053] Referring now to FIG. 7B, a top view of the 3D sensor 700 is illustrated with both the emitter 702 and the light blocker cover 707 removed for ease of illustration. The outer ring illustrates the footprint of the light diffuser 704. As light is emitted from the emitter 702 (not shown in FIG. 7B), it is diffused homogenously and directed to the tissue measurement site 102. The light blocker 706 forms the circular wall of a light isolation chamber to keep incident light from being sensed by the detector 710. The light blocker cover 707 blocks incidental light from entering the light isolation chamber from above. The light concentrator 710 collects the reflected light from the tissue measurement site 102 and funnels it upward toward the detector 710 at the center of the 3D sensor 700.

[0054] FIG. 8 illustrates an example of an optical physiological measurement system 800, which may also be referred to herein as a pulse oximetry system 800. In certain embodiments, the pulse oximetry system 800 noninvasively measures a blood analyte, such as oxygen, carboxyhemoglobin, methemoglobin, total hemoglobin, glucose, proteins, lipids, a percentage thereof (*e.g.*, saturation), pulse rate, perfusion index, oxygen content, total hemoglobin, Oxygen Reserve Index™ (ORI™) or many other physiologically relevant patient characteristics. These characteristics can relate to, for example, pulse rate, hydration, trending information and analysis, and the like. The system 800 can also measure additional blood

Marked-Up Specification

analytes and/or other physiological parameters useful in determining a state or trend of wellness of a patient.

[0055] The pulse oximetry system 800 can measure analyte concentrations at least in part by detecting optical radiation attenuated by tissue at a measurement site 102. The measurement site 102 can be any location on a patient's body, such as a finger, foot, earlobe, wrist, forehead, or the like.

[0056] The pulse oximetry system 800 can include a sensor 801 (or multiple sensors) that is coupled to a processing device or physiological monitor 809. In an embodiment, the sensor 801 and the monitor 809 are integrated together into a single unit. In another embodiment, the sensor 801 and the monitor 809 are separate from each other and communicate with one another in any suitable manner, such as via a wired or wireless connection. The sensor 801 and monitor 809 can be attachable and detachable from each other for the convenience of the user or caregiver, for ease of storage, sterility issues, or the like.

[0057] In the depicted embodiment shown in FIG. 8, the sensor 801 includes an emitter 804, a detector 806, and a front-end interface 808. The emitter 804 can serve as the source of optical radiation transmitted towards measurement site 102. The emitter 804 can include one or more sources of optical radiation, such as light emitting diodes (LEDs), laser diodes, incandescent bulbs with appropriate frequency-selective filters, combinations of the same, or the like. In an embodiment, the emitter 804 includes sets of optical sources that are capable of emitting visible and near-infrared optical radiation.

[0058] The pulse oximetry system 800 also includes a driver 811 that drives the emitter 804. The driver 111 can be a circuit or the like that is controlled by the monitor 809. For example, the driver 811 can provide pulses of current to the emitter 804. In an embodiment, the driver 811 drives the emitter 804 in a progressive fashion, such as in an alternating manner. The driver 811 can drive the emitter 804 with a series of pulses for some wavelengths that can penetrate tissue relatively well and for other wavelengths that tend to be significantly absorbed in tissue. A wide variety of other driving powers and driving methodologies can be used in various embodiments. The driver 811 can be synchronized with other parts

Marked-Up Specification

of the sensor 801 to minimize or reduce jitter in the timing of pulses of optical radiation emitted from the emitter 804. In some embodiments, the driver 811 is capable of driving the emitter 804 to emit optical radiation in a pattern that varies by less than about 10 parts-per-million.

[0059] The detector 806 captures and measures light from the tissue measurement site 102. For example, the detector 806 can capture and measure light transmitted from the emitter 804 that has been attenuated or reflected from the tissue at the measurement site 102. The detector 806 can output a detector signal 107 responsive to the light captured and measured. The detector 806 can be implemented using one or more photodiodes, phototransistors, or the like. In some embodiments, a detector 806 is implemented in detector package to capture and measure light from the tissue measurement site 102 of the patient. The detector package can include a photodiode chip mounted to leads and enclosed in an encapsulant. In some embodiments, the dimensions of the detector package are approximately 2 square centimeters. In other embodiments, the dimensions of the detector package are approximately 1.5 centimeters in width and approximately 2 centimeters in length.

[0060] The front-end interface 808 provides an interface that adapts the output of the detectors 806, which is responsive to desired physiological parameters. For example, the front-end interface 808 can adapt the signal 807 received from the detector 806 into a form that can be processed by the monitor 809, for example, by a signal processor 810 in the monitor 809. The front-end interface 808 can have its components assembled in the sensor 801, in the monitor 809, in a connecting cabling (if used), in combinations of the same, or the like. The location of the front-end interface 808 can be chosen based on various factors including space desired for components, desired noise reductions or limits, desired heat reductions or limits, and the like.

[0061] The front-end interface 808 can be coupled to the detector 806 and to the signal processor 810 using a bus, wire, electrical or optical cable, flex circuit, or some other form of signal connection. The front-end interface 808 can also be at least partially integrated with various components, such as the detectors 806. For

Marked-Up Specification

example, the front-end interface 808 can include one or more integrated circuits that are on the same circuit board as the detector 806. Other configurations can also be used.

[0062] As shown in FIG. 8, the monitor 909 can include the signal processor 810 and a user interface, such as a display 812. The monitor 809 can also include optional outputs alone or in combination with the display 812, such as a storage device 814 and a network interface 816. In an embodiment, the signal processor 810 includes processing logic that determines measurements for desired analytes based on the signals received from the detector 806. The signal processor 810 can be implemented using one or more microprocessors or sub-processors (*e.g.*, cores), digital signal processors, application specific integrated circuits (ASICs), field programmable gate arrays (FPGAs), combinations of the same, and the like.

[0063] The signal processor 810 can provide various signals that control the operation of the sensor 801. For example, the signal processor 810 can provide an emitter control signal to the driver 811. This control signal can be useful in order to synchronize, minimize, or reduce jitter in the timing of pulses emitted from the emitter 804. Accordingly, this control signal can be useful in order to cause optical radiation pulses emitted from the emitter 804 to follow a precise timing and consistent pattern. For example, when a transimpedance-based front-end interface 808 is used, the control signal from the signal processor 810 can provide synchronization with an analog-to-digital converter (ADC) in order to avoid aliasing, cross-talk, and the like. As also shown, an optional memory 813 can be included in the front-end interface 808 and/or in the signal processor 810. This memory 813 can serve as a buffer or storage location for the front-end interface 808 and/or the signal processor 810, among other uses.

[0064] The user interface 812 can provide an output, *e.g.*, on a display, for presentation to a user of the pulse oximetry system 800. The user interface 812 can be implemented as a touch-screen display, a liquid crystal display (LCD), an organic LED display, or the like. In alternative embodiments, the pulse oximetry system 800

Marked-Up Specification

can be provided without a user interface 812 and can simply provide an output signal to a separate display or system.

[0065] The storage device 814 and a network interface 816 represent other optional output connections that can be included in the monitor 809. The storage device 814 can include any computer-readable medium, such as a memory device, hard disk storage, EEPROM, flash drive, or the like. The various software and/or firmware applications can be stored in the storage device 814, which can be executed by the signal processor 810 or another processor of the monitor 809. The network interface 816 can be a serial bus port (RS-232/RS-485), a Universal Serial Bus (USB) port, an Ethernet port, a wireless interface (*e.g.*, WiFi such as any 802.1x interface, including an internal wireless card), or other suitable communication device(s) that allows the monitor 809 to communicate and share data with other devices. The monitor 809 can also include various other components not shown, such as a microprocessor, graphics processor, or controller to output the user interface 812, to control data communications, to compute data trending, or to perform other operations.

[0066] Although not shown in the depicted embodiment, the pulse oximetry system 800 can include various other components or can be configured in different ways. For example, the sensor 801 can have both the emitter 804 and detector 806 on the same side of the tissue measurement site 102 and use reflectance to measure analytes.

[0067] Although the foregoing disclosure has been described in terms of certain preferred embodiments, many other variations than those described herein will be apparent to those of ordinary skill in the art.

[0068] Conditional language used herein, such as, among others, "can," "might," "may," "*e.g.*," and the like, unless specifically stated otherwise, or otherwise understood within the context as used, is generally intended to convey that certain embodiments include, while other embodiments do not include, certain features, elements and/or states. Thus, such conditional language is not generally intended to imply that features, elements and/or states are in any way required for one or more embodiments or that one or more embodiments necessarily include logic for

Marked-Up Specification

deciding, with or without author input or prompting, whether these features, elements and/or states are included or are to be performed in any particular embodiment. The terms "comprising," "including," "having," and the like are synonymous and are used inclusively, in an open-ended fashion, and do not exclude additional elements, features, acts, operations, and so forth. Also, the term "or" is used in its inclusive sense (and not in its exclusive sense) so that when used, for example, to connect a list of elements, the term "or" means one, some, or all of the elements in the list. Further, the term "each," as used herein, in addition to having its ordinary meaning, can mean any subset of a set of elements to which the term "each" is applied.

[0069] While the above detailed description has shown, described, and pointed out novel features as applied to various embodiments, it will be understood that various omissions, substitutions, and changes in the form and details of the systems, devices or algorithms illustrated can be made without departing from the spirit of the disclosure. As will be recognized, certain embodiments of the disclosure described herein can be embodied within a form that does not provide all of the features and benefits set forth herein, as some features can be used or practiced separately from others.

[0070] The term "and/or" herein has its broadest, least limiting meaning which is the disclosure includes A alone, B alone, both A and B together, or A or B alternatively, but does not require both A and B or require one of A or one of B. As used herein, the phrase "at least one of" A, B, "and" C should be construed to mean a logical A or B or C, using a non-exclusive logical or.

[0071] The apparatuses and methods described herein may be implemented by one or more computer programs executed by one or more processors. The computer programs include processor-executable instructions that are stored on a non-transitory tangible computer readable medium. The computer programs may also include stored data. Non-limiting examples of the non-transitory tangible computer readable medium are nonvolatile memory, magnetic storage, and optical storage. Although the foregoing disclosure has been described in terms of certain preferred embodiments, other embodiments will be apparent to those of

Marked-Up Specification

ordinary skill in the art from the disclosure herein. Additionally, other combinations, omissions, substitutions and modifications will be apparent to the skilled artisan in view of the disclosure herein. Accordingly, the present invention is not intended to be limited by the description of the preferred embodiments, but is to be defined by reference to claims.

[0072] Additionally, all publications, patents, and patent applications mentioned in this specification are herein incorporated by reference to the same extent as if each individual publication, patent, or patent application were specifically and individually indicated to be incorporated by reference.

Clean Specification

MASIMO.1007A

PATENT

ADVANCED PULSE OXIMETRY SENSOR

INCORPORATION BY REFERENCE TO ANY PRIORITY APPLICATIONS

[0001] This present application claims priority benefit under 35 U.S.C. § 119(e) from U.S. Provisional Application No. 62/188,430, filed July 2, 2015, entitled “Advanced Pulse Oximetry Sensor,” which is incorporated by reference herein. Any and all applications for which a foreign or domestic priority claim is identified in the Application Data Sheet as filed with the present application are hereby incorporated by reference under 37 CFR 1.57.

FIELD OF THE DISCLOSURE

[0002] The present disclosure relates to the field of non-invasive optical-based physiological monitoring sensors, and more particularly to systems, devices and methods for improving the non-invasive measurement accuracy of oxygen saturation, among other physiological parameters.

BACKGROUND

[0003] Spectroscopy is a common technique for measuring the concentration of organic and some inorganic constituents of a solution. The theoretical basis of this technique is the Beer-Lambert law, which states that the concentration c_i of an absorbent in solution can be determined by the intensity of light transmitted through the solution, knowing the pathlength d_λ , the intensity of the incident light $I_{o,\lambda}$, and the extinction coefficient $\varepsilon_{i,\lambda}$ at a particular wavelength λ .

[0004] In generalized form, the Beer-Lambert law is expressed as:

$$I_\lambda = I_{o,\lambda} e^{-d_\lambda \cdot \mu_{a,\lambda}} \quad (1)$$

$$\mu_{a,\lambda} = \sum_{i=1}^n \varepsilon_{i,\lambda} \cdot c_i \quad (2)$$

where $\mu_{a,\lambda}$ is the bulk absorption coefficient and represents the probability of absorption per unit length. The minimum number of discrete wavelengths that are

Clean Specification

required to solve equations 1 and 2 is the number of significant absorbers that are present in the solution.

[0005] A practical application of this technique is pulse oximetry, which utilizes a noninvasive sensor to measure oxygen saturation and pulse rate, among other physiological parameters. Pulse oximetry relies on a sensor attached externally to the patient to output signals indicative of various physiological parameters, such as a patient's blood constituents and/or analytes, including for example a percent value for arterial oxygen saturation, among other physiological parameters. The sensor has an emitter that transmits optical radiation of one or more wavelengths into a tissue site and a detector that responds to the intensity of the optical radiation after absorption by pulsatile arterial blood flowing within the tissue site. Based upon this response, a processor determines the relative concentrations of oxygenated hemoglobin (HbO₂) and deoxygenated hemoglobin (Hb) in the blood so as to derive oxygen saturation, which can provide early detection of potentially hazardous decreases in a patient's oxygen supply.

[0006] A pulse oximetry system generally includes a patient monitor, a communications medium such as a cable, and/or a physiological sensor having one or more light emitters and a detector, such as one or more light-emitting diodes (LEDs) and a photodetector. The sensor is attached to a tissue site, such as a finger, toe, earlobe, nose, hand, foot, or other site having pulsatile blood flow which can be penetrated by light from the one or more emitters. The detector is responsive to the emitted light after attenuation or reflection by pulsatile blood flowing in the tissue site. The detector outputs a detector signal to the monitor over the communication medium. The monitor processes the signal to provide a numerical readout of physiological parameters such as oxygen saturation (SpO₂) and/or pulse rate. A pulse oximetry sensor is described in U.S. Patent No. 6,088,607 entitled *Low Noise Optical Probe*; pulse oximetry signal processing is described in U.S. Patent Nos. 6,650,917 and 6,699,194 entitled *Signal Processing Apparatus* and *Signal Processing Apparatus and Method*, respectively; a pulse oximeter monitor is described in U.S. Patent No. 6,584,336 entitled *Universal/Upgrading Pulse*

Clean Specification

Oximeter; all of which are assigned to Masimo Corporation, Irvine, CA, and each is incorporated by reference herein in its entirety.

[0007] There are many sources of measurement error introduced to pulse oximetry systems. Some such sources of error include the pulse oximetry system's electronic components, including emitters and detectors, as well as chemical and structural physiological differences between patients. Another source of measurement error is the effect of multiple scattering of photons as the photons pass through the patient's tissue (arterial blood) and arrive at the sensor's light detector.

SUMMARY

[0008] This disclosure describes embodiments of non-invasive methods, devices, and systems for measuring blood constituents, analytes, and/or substances such as, by way of non-limiting example, oxygen, carboxyhemoglobin, methemoglobin, total hemoglobin, glucose, proteins, lipids, a percentage thereof (*e.g.*, saturation), pulse rate, perfusion index, oxygen content, total hemoglobin, Oxygen Reserve Index™ (ORI™) or for measuring many other physiologically relevant patient characteristics. These characteristics can relate to, for example, pulse rate, hydration, trending information and analysis, and the like.

[0009] In an embodiment, an optical physiological measurement system includes an emitter configured to emit light of one or more wavelengths. The system also includes a diffuser configured to receive the emitted light, to spread the received light, and to emit the spread light over a larger tissue area than would otherwise be penetrated by the emitter directly emitting light at a tissue measurement site. The tissue measurement site can include, such as, for example, a finger, a wrist, or the like. The system further includes a concentrator configured to receive the spread light after it has been attenuated by or reflected from the tissue measurement site. The concentrator is also configured to collect and concentrate the received light and to emit the concentrated light to a detector. The detector is configured to detect the concentrated light and to transmit a signal indicative of the detected light. The system also includes a processor configured to receive the

Clean Specification

transmitted signal indicative of the detected light and to determine, based on an amount of absorption, an analyte of interest, such as, for example, arterial oxygen saturation or other parameter, in the tissue measurement site.

[0010] In certain embodiments of the present disclosure, the diffuser comprises glass, ground glass, glass beads, opal glass, or a microlens-based, band-limited, engineered diffuser that can deliver efficient and uniform illumination. In some embodiments the diffuser is further configured to define a surface area shape by which the emitted spread light is distributed onto a surface of the tissue measurement site. The defined surface area shape can include, by way of non-limiting example, a shape that is substantially rectangular, square, circular, oval, or annular, among others.

[0011] According to some embodiments, the optical physiological measurement system includes an optical filter having a light-absorbing surface that faces the tissue measurement site. The optical filter also has an opening that is configured to allow the spread light, after being attenuated by the tissue measurement site, to be received by the concentrator. In an embodiment, the opening has dimensions, wherein the dimensions of the opening are similar to the defined surface area shape by which the emitted spread light is distributed onto the surface of the tissue measurement site. In an embodiment, the opening has dimensions that are larger than the defined surface area shape by which the emitted spread light is distributed onto the surface of the tissue measurement site. In other embodiments, the dimensions of the opening in the optical filter are not the same as the diffuser opening, but the dimensions are larger than the detector package.

[0012] In other embodiments of the present disclosure, the concentrator comprises glass, ground glass, glass beads, opal glass, or a compound parabolic concentrator. In some embodiments the concentrator comprises a cylindrical structure having a truncated circular conical structure on top. The truncated section is adjacent the detector. The light concentrator is structured to receive the emitted optical radiation, after reflection by the tissue measurement site, and to direct the reflected light to the detector.

Clean Specification

[0013] In accordance with certain embodiments of the present disclosure, the processor is configured to determine an average level of the light detected by the detector. The average level of light is used to determine a physiological parameter in the tissue measurement site.

[0014] According to another embodiment, a method to determine a constituent or analyte in a patient's blood is disclosed. The method includes emitting, from an emitter, light of at least one wavelength; spreading, with a diffuser, the emitted light and emitting the spread light from the diffuser to a tissue measurement site; receiving, by a concentrator, the spread light after the spread light has been attenuated by the tissue measurement site; concentrating, by the concentrator, the received light and emitting the concentrated light from the concentrator to a detector; detecting, with the detector, the emitted concentrated light; transmitting, from the detector, a signal responsive to the detected light; receiving, by a processor, the transmitted signal responsive to the detected light; and processing, by the processor, the received signal responsive to the detected light to determine a physiological parameter.

[0015] In some embodiments, the method to determine a constituent or analyte in a patient's blood includes filtering, with a light-absorbing detector filter, scattered portions of the emitted spread light. According to an embodiment, the light-absorbing detector filter is substantially rectangular in shape and has outer dimensions in the range of approximately 1-5 cm in width and approximately 2-8 cm in length, and has an opening through which emitted light may pass, the opening having dimensions in the range of approximately 0.25-3 cm in width and approximately 1-7 cm in length. In another embodiment, the light-absorbing detector filter is substantially square in shape and has outer dimensions in the range of approximately 0.25-10 cm², and has an opening through which emitted light may pass, the opening having dimensions in the range of approximately 0.1-8cm². In yet another embodiment, the light-absorbing detector filter is substantially rectangular in shape and has outer dimensions of approximately 3 cm in width and approximately 6 cm in length, and has an opening through which emitted light may pass, the

Clean Specification

opening having dimensions of approximately 1.5 cm in width and approximately 4 cm in length.

[0016] In still other embodiments of the method to determine a constituent or analyte in a patient's blood, spreading, with a diffuser, the emitted light and emitting the spread light from the diffuser to a tissue measurement site is performed by at least one of a glass diffuser, a ground glass diffuser, a glass bead diffuser, an opal glass diffuser, and an engineered diffuser. In some embodiments the emitted spread light is emitted with a substantially uniform intensity profile. And in some embodiments, emitting the spread light from the diffuser to the tissue measurement site includes spreading the emitted light so as to define a surface area shape by which the emitted spread light is distributed onto a surface of the tissue measurement site.

[0017] According to yet another embodiment, a pulse oximeter is disclosed. The pulse oximeter includes an emitter configured to emit light at one or more wavelengths. The pulse oximeter also includes a diffuser configured to receive the emitted light, to spread the received light, and to emit the spread light directed at a tissue measurement sight. The pulse oximeter also includes a detector configured to detect the emitted spread light after being attenuated by or reflected from the tissue measurement site and to transmit a signal indicative of the detected light. The pulse oximeter also includes a processor configured to receive the transmitted signal and to process the received signal to determine an average absorbance of a blood constituent or analyte in the tissue measurement site over a larger measurement site area than can be performed with a point light source or point detector. In some embodiments, the diffuser is further configured to define a surface area shape by which the emitted spread light is distributed onto a surface of the tissue measurement site, and the detector is further configured to have a detection area corresponding to the defined surface area shape by which the emitted spread light is distributed onto the surface of the tissue measurement site. According to some embodiments, the detector comprises an array of detectors configured to cover the detection area. In still other embodiments, the processor is further configured to determine an average of the detected light.

Clean Specification

[0018] For purposes of summarizing, certain aspects, advantages and novel features of the disclosure have been described herein. It is to be understood that not necessarily all such advantages can be achieved in accordance with any particular embodiment of the systems, devices and/or methods disclosed herein. Thus, the subject matter of the disclosure herein can be embodied or carried out in a manner that achieves or optimizes one advantage or group of advantages as taught herein without necessarily achieving other advantages as can be taught or suggested herein.

BRIEF DESCRIPTION OF THE DRAWINGS

[0019] Throughout the drawings, reference numbers can be re-used to indicate correspondence between referenced elements. The drawings are provided to illustrate embodiments of the disclosure described herein and not to limit the scope thereof.

[0020] FIG. 1 illustrates a conventional approach to two-dimensional pulse oximetry in which the emitter is configured to emit optical radiation as a point optical source.

[0021] FIG. 2 illustrates the disclosed three-dimensional approach to pulse oximetry in which the emitted light irradiates a substantially larger volume of tissue as compared to the point source approach described with respect to FIG. 1.

[0022] FIG. 3 illustrates schematically a side view of a three-dimensional pulse oximetry sensor according to an embodiment of the present disclosure.

[0023] FIG. 4A is a top view of a portion of a three-dimensional pulse oximetry sensor according to an embodiment of the present disclosure.

[0024] FIG. 4B illustrates the top view of a portion of the three-dimensional pulse oximetry sensor shown in FIG. 4A, with the addition of a tissue measurement site in operational position.

[0025] FIG. 5 illustrates a top view of a three-dimensional pulse oximetry sensor according to an embodiment of the present disclosure.

Clean Specification

[0026] FIG. 6 illustrates a conventional two-dimensional approach to reflective pulse oximetry in which the emitter is configured to emit optical radiation as a point optical source.

[0027] FIG. 7A is a simplified schematic side view illustration of a reflective three-dimensional pulse oximetry sensor according to an embodiment of the present disclosure.

[0028] FIG. 7B is a simplified schematic top view illustration of the three-dimensional reflective pulse oximetry sensor of FIG. 7A.

[0029] FIG. 8 illustrates a block diagram of an example pulse oximetry system capable of noninvasively measuring one or more blood analytes in a monitored patient, according to an embodiment of the disclosure.

DETAILED DESCRIPTION

[0030] FIG. 1 illustrates schematically a conventional pulse oximetry sensor having a two-dimensional (2D) approach to pulse oximetry. As illustrated, the emitter 104 is configured to emit optical radiation as a point optical source, *i.e.*, an optical radiation source that has negligible dimensions such that it may be considered as a point. This approach is referred to herein as “two-dimensional” pulse oximetry because it applies a two-dimensional analytical model to the three-dimensional space of the tissue measurement site 102 of the patient. Point optical sources feature a defined, freely selectable, and homogeneous light beam area. Light beams emitted from LED point sources often exhibit a strong focus which can produce a usually sharply-defined and evenly-lit illuminated spot often with high intensity dynamics. Illustratively, when looking at the surface of the tissue measurement site 102 (or “sample tissue”), which in this example is a finger, a small point-like surface area of tissue 204 is irradiated by a point optical source. In some embodiments, the irradiated circular area of the point optical source is in the range between 8 and 150 microns. Illustratively, the emitted point optical source of light enters the tissue measurement site 102 as a point of light. As the light penetrates the depth of the tissue 102, it does so as a line or vector, representing a

Clean Specification

two-dimensional construct within a three-dimensional structure, namely the patient's tissue 102.

[0031] Use of a point optical source is believed to reduce variability in light pathlength which would lead to more accurate oximetry measurements. However, in practice, photons do not travel in straight paths. Instead, the light particles scatter, bouncing around between various irregular objects (such as, for example, red blood cells) in the patient's blood. Accordingly, photon pathlengths vary depending on, among other things, their particular journeys through and around the tissue at the measurement site 102. This phenomenon is referred to as "multiple scattering." In a study, the effects of multiple scattering were examined by comparing the results of photon diffusion analysis with those obtained using an analysis based on the Beer-Lambert law, which neglects multiple scattering in the determination of light pathlength. The study found that that the difference between the average lengths of the paths traveled by red and infrared photons makes the oximeter's calibration curve (based on measurements obtained from normal subjects) sensitive to the total attenuation coefficients of the tissue in the two wavelength bands used for pulse oximetry, as well as to absorption by the pulsating arterial blood.

[0032] FIG. 2 illustrates schematically the disclosed systems, devices, and methods to implement three-dimensional (3D) pulse oximetry in which the emitted light irradiates a larger volume of tissue at the measurement site 102 as compared to the 2D point optical source approach described with respect to FIG. 1. In an embodiment, again looking at the surface of the tissue measurement site 102, the irradiated surface area 206 of the measurement site 102 is substantially rectangular in shape with dimensions in the range of approximately 0.25-3 cm in width and approximately 1-6 cm in length. In another embodiment, the irradiated surface area 206 of the measurement site 102 is substantially rectangular in shape and has dimensions of approximately 1.5 cm in width and approximately 2 cm in length. In another embodiment, the irradiated surface area 206 of the measurement site 102 is substantially rectangular in shape and has dimensions of approximately 0.5 cm in width and approximately 1 cm in length. In another embodiment, the irradiated surface area 206 of the measurement site 102 is substantially rectangular in shape

Clean Specification

has dimensions of approximately 1 cm in width and approximately 1.5 cm in length. In yet another embodiment, the irradiated surface area 206 of the measurement site 102 is substantially square in shape and has dimensions in a range of approximately 0.25-9 cm². In certain embodiments, the irradiated surface area 206 of the measurement site 102 is within a range of approximately 0.5-2 cm in width, and approximately 1-4 cm in length. Of course a skilled artisan will appreciate that many other shapes and dimensions of irradiated surface area 206 can be used. Advantageously, by irradiating the tissue measurement site 102 with a surface area 206, the presently disclosed systems, devices, and methods apply a three-dimensional analytical model to the three-dimensional structure being measured, namely, the patient's sample tissue 102.

[0033] According to the Beer-Lambert law, the amount of light absorbed by a substance is proportional to the concentration of the light-absorbing substance in the irradiated solution (*i.e.*, arterial blood). Advantageously, by irradiating a larger volume of tissue 102, a larger sample size of light attenuated (or reflected) by the tissue 102 is measured. The larger, 3D sample provides a data set that is more representative of the complete interaction of the emitted light as it passes through the patient's blood as compared to the 2D point source approach described above with respect to FIG. 1. By taking an average of the detected light, as detected over a surface area substantially larger than a single point, the disclosed pulse oximetry systems, devices, and methods will yield a more accurate measurement of the emitted light absorbed by the tissue, which will lead to a more accurate oxygen saturation measurement.

[0034] FIG. 3 illustrates schematically a side view of a pulse oximetry 3D sensor 300 according to an embodiment of the present disclosure. In the illustrated embodiment, the 3D sensor 300 irradiates the tissue measurement site 102 and detects the emitted light, after being attenuated by the tissue measurement site 102. In other embodiments, for example, as describe below with respect to FIGS. 7A and 7B, the 3D sensor 300 can be arranged to detect light that is reflected by the tissue measurement site 102. The 3D sensor 300 includes an emitter 302, a light diffuser 304, a light-absorbing detector filter 306, a light concentrator 308, and a detector

Clean Specification

310. In some optional embodiments, the 3D sensor 300 further includes a reflector 305. The reflector 305 can be a metallic reflector or other type of reflector. Reflector 305 can be a coating, film, layer or other type of reflector. The reflector 305 can serve as a reflector to prevent emitted light from emitting out of a top portion of the light diffuser 304 such that light from the emitter 302 is directed in the tissue rather than escaping out of a side or top of the light diffuser 304. Additionally, the reflector 305 can prevent ambient light from entering the diffuser 304 which might ultimately cause errors within the detected light. The reflector 305 also prevent light piping that might occur if light from the detector 302 is able to escape from the light diffuser 304 and be piped around a sensor securement mechanism to detector 310 without passing through the patient's tissue 102.

[0035] The emitter 302 can serve as the source of optical radiation transmitted towards the tissue measurement site 102. The emitter 302 can include one or more sources of optical radiation, such as LEDs, laser diodes, incandescent bulbs with appropriate frequency-selective filters, combinations of the same, or the like. In an embodiment, the emitter 302 includes sets of optical sources that are capable of emitting visible and near-infrared optical radiation. In some embodiments, the emitter 302 transmits optical radiation of red and infrared wavelengths, at approximately 650 nm and approximately 940 nm, respectively. In some embodiments, the emitter 302 includes a single source optical radiation.

[0036] The light diffuser 304 receives the optical radiation emitted from the emitter 302 and spreads the optical radiation over an area, such as the area 206 depicted in FIG. 2. In some embodiments, the light diffuser 304 is a beam shaper that can homogenize the input light beam from the emitter 302, shape the output intensity profile of the received light, and define the way (*e.g.*, the shape or pattern) the emitted light is distributed to the tissue measurement site 102. Examples of materials that can be used to realize the light diffuser 304 include, without limitation, a white surface, glass, ground glass, glass beads, polytetrafluoroethylene (also known as Teflon®, opal glass, and greyed glass, to name a few. Additionally, engineered diffusers can be used to realize the diffuser 304 by providing customized light shaping with respect to intensity and distribution. Such diffusers can, for

Clean Specification

example, deliver substantially uniform illumination over a specified target area (such as, for example, irradiated surface area 206) in an energy-efficient manner. Examples of engineered diffusers can include molded plastics with specific shapes, patterns or textures designed to diffuse the emitter light across the entirety of the patient's tissue surface.

[0037] Advantageously, the diffuser 304 can receive emitted light in the form of a point optical source and spread the light to fit a desired surface area on a plane defined by the surface of the tissue measurement site 102. In an embodiment, the diffuser 304 is made of ground glass which spreads the emitted light with a Gaussian intensity profile. In another embodiment the diffuser 304 includes glass beads. In some embodiments, the diffuser 304 is constructed so as to diffuse the emitted light in a Lambertian pattern. A Lambertian pattern is one in which the radiation intensity is substantially constant throughout the area of dispersion. One such diffuser 304 is made from opal glass. Opal glass is similar to ground glass, but has one surface coated with a milky white coating to diffuse light evenly. In an embodiment, the diffuser 304 is capable of distributing the emitted light on the surface of a plane (*e.g.*, the surface of the tissue measurement site 102) in a predefined geometry (*e.g.*, a rectangle, square, or circle), and with a substantially uniform intensity profile and energy distribution. In some embodiments, the efficiency, or the amount of light transmitted by the diffuser 304, is greater than 70% of the light emitted by the emitter 302. In some embodiments, the efficiency is greater than 90% of the emitted light. Other optical elements known in the art may be used for the diffuser 304.

[0038] In an embodiment, the diffuser 304 has a substantially rectangular shape having dimensions within a range of approximately 0.5-2 cm in width and approximately 1-4 centimeters in length. In another embodiment, the substantially rectangular shape of the diffuser 304 has dimensions of approximately 0.5 cm in width and approximately 1 cm in length. In another embodiment, the diffuser's 304 substantially rectangular shape has dimensions of approximately 1 cm in width and approximately 1.5 cm in length. In yet another embodiment, the diffuser 304 has a

Clean Specification

substantially square shape with dimensions in the range of approximately 0.25-10 cm².

[0039] The light-absorbing detector filter 306, which is also depicted in FIG. 4A in a top view, is a planar surface having an opening 402 through which the emitted light may pass after being attenuated by the tissue measurement site 102. In the depicted embodiment, the opening 402 is rectangular-shaped, with dimensions substantially similar to the irradiated surface area 206. According to an embodiment, the light-absorbing detector filter is substantially rectangular in shape and has outer dimensions of 4 cm in width and 8 cm in length, and has an opening through which emitted light may pass, the opening having dimensions of 2 cm in width and 5 cm in length. In another embodiment, the light-absorbing detector filter is substantially rectangular in shape and has outer dimensions in the range of 1-3 cm in width and 2-8 cm in length, and has an opening through which emitted light may pass, the opening having dimensions in the range of 0.25-2 cm in width and 1-4 cm in length. In yet another embodiment, the light-absorbing detector filter is substantially rectangular in shape and has outer dimensions of 3 cm in width and 6 cm in length, and has an opening through which emitted light may pass, the opening having dimensions of 1.5 cm in width and 4 cm in length.

[0040] The top surface of the light-absorbing filter 306 (facing the tissue measurement site 102 and the emitter 302) is coated with a material that absorbs light, such as, for example, black pigment. Many other types of light-absorbing materials are well known in the art and can be used with the detector filter 306. During operation, light emitted from the emitter 302 can reflect off of the tissue measurement site 102 (or other structures within the 3D sensor 300) to neighboring portions of the 3D sensor 300. If those neighboring portions of the 3D sensor 300 possess reflective surfaces, then the light can reflect back to the tissue measurement site 102, progress through the tissue and arrive at the detector 310. Such multiple scattering can result in detecting photons whose pathlengths are considerably longer than most of the light that is detected, thereby introducing variations in pathlength which will affect the accuracy of the measurements of the pulse oximetry 3D sensor 300. Advantageously, the light-absorbing filter 306

Clean Specification

reduces or eliminates the amount of emitted light that is reflected in this manner because it absorbs such reflected light, thereby stopping the chain of scattering events. In certain embodiments, the sensor-facing surfaces of other portions of the 3D sensor 300 are covered in light-absorbing material to further decrease the effect of reflective multiple scattering.

[0041] The light concentrator 308 is a structure to receive the emitted optical radiation, after attenuation by the tissue measurement site 102, to collect and concentrate the dispersed optical radiation, and to direct the collected and concentrated optical radiation to the detector 310. In an embodiment, the light concentrator 308 is made of ground glass or glass beads. In some embodiments, the light concentrator 308 includes a compound parabolic concentrator.

[0042] As described above with respect to FIG. 1, the detector 310 captures and measures light from the tissue measurement site 102. For example, the detector 310 can capture and measure light transmitted from the emitter 302 that has been attenuated by the tissue in the measurement site 102. The detector 310 can output a detector signal responsive to the light captured or measured. The detector 310 can be implemented using one or more photodiodes, phototransistors, or the like. In addition, a plurality of detectors 310 can be arranged in an array with a spatial configuration corresponding to the irradiated surface area 206 to capture the attenuated or reflected light from the tissue measurement site.

[0043] Referring to FIG. 4A, a top view of a portion of the 3D sensor 300 is provided. The light-absorbing detector filter 306 is illustrated having a top surface coated with a light-absorbing material. The light-absorbing material can be a black opaque material or coating or any other dark color or coating configured to absorb light. Additionally, a rectangular opening 402 is positioned relative to the light concentrator 308 (shown in phantom) and the detector 310 such that light may pass through the rectangular opening 402, into the light concentrator 308, and to the detector 310. FIG. 4B illustrates the top view of a portion of the 3D sensor 300 as in FIG. 4A, with the addition of the tissue measurement site 102 in operational position. Accordingly, the rectangular opening 402, the light concentrator 308 and the detector 310 are shown in phantom as being under the tissue measurement site

Clean Specification

102. In FIGS. 4A and 4B, the light concentrator 308 is shown to have dimensions significantly larger than the dimensions of the rectangular opening 402. In other embodiments, the dimensions of the light concentrator 308, the rectangular opening 402, and the irradiated surface area 206 are substantially similar.

[0044] FIG. 5 illustrates a top view of a 3D pulse oximetry sensor 500 according to an embodiment of the present disclosure. The 3D sensor 500 is configured to be worn on a patient's finger 102. The 3D sensor 500 includes an adhesive substrate 502 having front flaps 504 and rear flaps 506 extending outward from a center portion 508 of the 3D sensor 500. The center portion 508 includes components of the 3D pulse oximetry sensor 300 described with respect to FIGS. 3, 4A and 4B. On the front side of the adhesive substrate 502 the emitter 302 and the light diffuser 304 are positioned. On the rear side of the adhesive substrate 502 the light-absorbent detector filter 306, the light concentrator 308 and the detector 310 are positioned. In use, the patient's finger serving as the tissue measurement site 102 is positioned over the rectangular opening 402 such that when the front portion of the adhesive substrate is folded over on top of the patient's finger 102, the emitter 302 and the light diffuser 304 are aligned with the measurement site 102, the filter 306, the light concentrator 308 and the detector 310. Once alignment is established, the front and rear flaps 504, 506 can be wrapped around the finger measurement site 102 such that the adhesive substrate 502 provides a secure contact between the patient's skin and the 3D sensor 500. Fig. 5 also illustrates an example of a sensor connector cable 510 which is used to connect the 3D sensor 500 to a monitor 809, as described with respect to FIG. 8.

[0045] FIG. 6 is a simplified schematic illustration of a conventional, 2D approach to reflective pulse oximetry in which the emitter is configured to emit optical radiation as a point optical source. Reflective pulse oximetry is a method by which the emitter and detector are located on the same side of the tissue measurement site 102. Light is emitted into a tissue measurement site 102 and attenuated. The emitted light passes into the tissue 102 and is then reflected back to the same side of the tissue measurement site 102 as the emitter. As illustrated in FIG. 6, a depicted reflective 2D pulse oximetry sensor 600 includes an emitter 602,

Clean Specification

a light block 606, and a detector 610. The light block 606 is necessary because the emitter 602 and the detector 610 are located on the same side of the tissue measurement site 102. Accordingly, the light block 606 prevents incident emitter light, which did not enter the tissue measurement site 102, from arriving at the detector 610. The depicted 2D pulse oximetry sensor 600 is configured to emit light as a point source. As depicted in FIG. 6, a simplified illustration of the light path 620 of the emitted light from the emitter 602, through the tissue measurement site 102, and to the detector 610 is provided. Notably, a point source of light is emitted, and a point source of light is detected. As discussed above with respect to FIG. 1, use of a point optical source can result in substantial measurement error due to pathlength variability resulting from the multiple scatter phenomenon. The sample space provided by a 2D point optical emitter source is not large enough to account for pathlength variability, which will skew measurement results.

[0046] FIGS. 7A and 7B are simplified schematic side and top views, respectively, of a 3D reflective pulse oximetry sensor 700 according to an embodiment of the present disclosure. In the illustrated embodiment, the 3D sensor 700 irradiates the tissue measurement site 102 and detects the emitted light that is reflected by the tissue measurement site 102. The 3D sensor 700 can be placed on a portion of the patient's body that has relatively flat surface, such as, for example a wrist, because the emitter 702 and detector 710 are on located the same side of the tissue measurement site 102. The 3D sensor 700 includes an emitter 702, a light diffuser 704, a light block 706, a light concentrator 708, and a detector 710.

[0047] As previously described, the emitter 702 can serve as the source of optical radiation transmitted towards the tissue measurement site 102. The emitter 702 can include one or more sources of optical radiation. Such sources of optical radiation can include LEDs, laser diodes, incandescent bulbs with appropriate frequency-selective filters, combinations of the same, or the like. In an embodiment, the emitter 702 includes sets of optical sources that are capable of emitting visible and near-infrared optical radiation. In some embodiments, the emitter 702 transmits optical radiation of red and infrared wavelengths, at approximately 650 nm and

Clean Specification

approximately 940 nm, respectively. In some embodiments, the emitter 702 includes a single source of optical radiation.

[0048] The light diffuser 704 receives the optical radiation emitted from the emitter 302 and homogeneously spreads the optical radiation over a wide, donut-shaped area, such as the area outlined by the light diffuser 704 as depicted in FIG. 7B. Advantageously, the diffuser 704 can receive emitted light in the form of a 2D point optical source (or any other form) and spread the light to fit the desired surface area on a plane defined by the surface of the tissue measurement site 102. In an embodiment, the diffuser 704 is made of ground glass or glass beads. A skilled artisan will understand that many other materials can be used to make the light diffuser 704.

[0049] The light blocker 706 includes an annular ring having a cover portion 707 sized and shaped to form a light isolation chamber for the light concentrator 708 and the detector 710. (For purposes of illustration, the light block cover 707 is not illustrated in FIG. 7B.) The light blocker 706 and the cover 707 can be made of any material that optically isolates the light concentrator 708 and the detector 710. The light isolation chamber formed by the light blocker 706 and cover 707 ensures that the only light detected by the detector 710 is light that is reflected from the tissue measurement site.

[0050] The light concentrator 708 is a cylindrical structure with a truncated circular conical structure on top, the truncated section of which is adjacent the detector 710. The light concentrator 708 is structured to receive the emitted optical radiation, after reflection by the tissue measurement site 102, and to direct the reflected light to the detector 710. In an embodiment, the light concentrator 708 is made of ground glass or glass beads. In some embodiments, the light concentrator 708 includes a compound parabolic concentrator.

[0051] As previously described, the detector 710 captures and measures light from the tissue measurement site 102. For example, the detector 710 can capture and measure light transmitted from the emitter 702 that has been reflected from the tissue in the measurement site 102. The detector 710 can output a detector signal responsive to the light captured or measured. The detector 710 can be

Clean Specification

implemented using one or more photodiodes, phototransistors, or the like. In addition, a plurality of detectors 710 can be arranged in an array with a spatial configuration corresponding to the irradiated surface area depicted in FIG. 7B by the light concentrator 708 to capture the reflected light from the tissue measurement site.

[0052] Advantageously, the light path 720 illustrated in FIG. 7A depicts a substantial sample of reflected light that enter the light isolation chamber formed by the light blocker 706 and cover 707. As previously discussed, the large sample of reflected light (as compared to the reflected light collected using the 2D point optical source approach) provides the opportunity to take an average of the detected light, to derive a more accurate measurement of the emitted light absorbed by the tissue, which will lead to a more accurate oxygen saturation measurement.

[0053] Referring now to FIG. 7B, a top view of the 3D sensor 700 is illustrated with both the emitter 702 and the light blocker cover 707 removed for ease of illustration. The outer ring illustrates the footprint of the light diffuser 704. As light is emitted from the emitter 702 (not shown in FIG. 7B), it is diffused homogenously and directed to the tissue measurement site 102. The light blocker 706 forms the circular wall of a light isolation chamber to keep incident light from being sensed by the detector 710. The light blocker cover 707 blocks incidental light from entering the light isolation chamber from above. The light concentrator 710 collects the reflected light from the tissue measurement site 102 and funnels it upward toward the detector 710 at the center of the 3D sensor 700.

[0054] FIG. 8 illustrates an example of an optical physiological measurement system 800, which may also be referred to herein as a pulse oximetry system 800. In certain embodiments, the pulse oximetry system 800 noninvasively measures a blood analyte, such as oxygen, carboxyhemoglobin, methemoglobin, total hemoglobin, glucose, proteins, lipids, a percentage thereof (*e.g.*, saturation), pulse rate, perfusion index, oxygen content, total hemoglobin, Oxygen Reserve Index™ (ORI™) or many other physiologically relevant patient characteristics. These characteristics can relate to, for example, pulse rate, hydration, trending information and analysis, and the like. The system 800 can also measure additional blood

Clean Specification

analytes and/or other physiological parameters useful in determining a state or trend of wellness of a patient.

[0055] The pulse oximetry system 800 can measure analyte concentrations at least in part by detecting optical radiation attenuated by tissue at a measurement site 102. The measurement site 102 can be any location on a patient's body, such as a finger, foot, earlobe, wrist, forehead, or the like.

[0056] The pulse oximetry system 800 can include a sensor 801 (or multiple sensors) that is coupled to a processing device or physiological monitor 809. In an embodiment, the sensor 801 and the monitor 809 are integrated together into a single unit. In another embodiment, the sensor 801 and the monitor 809 are separate from each other and communicate with one another in any suitable manner, such as via a wired or wireless connection. The sensor 801 and monitor 809 can be attachable and detachable from each other for the convenience of the user or caregiver, for ease of storage, sterility issues, or the like.

[0057] In the depicted embodiment shown in FIG. 8, the sensor 801 includes an emitter 804, a detector 806, and a front-end interface 808. The emitter 804 can serve as the source of optical radiation transmitted towards measurement site 102. The emitter 804 can include one or more sources of optical radiation, such as light emitting diodes (LEDs), laser diodes, incandescent bulbs with appropriate frequency-selective filters, combinations of the same, or the like. In an embodiment, the emitter 804 includes sets of optical sources that are capable of emitting visible and near-infrared optical radiation.

[0058] The pulse oximetry system 800 also includes a driver 811 that drives the emitter 804. The driver 111 can be a circuit or the like that is controlled by the monitor 809. For example, the driver 811 can provide pulses of current to the emitter 804. In an embodiment, the driver 811 drives the emitter 804 in a progressive fashion, such as in an alternating manner. The driver 811 can drive the emitter 804 with a series of pulses for some wavelengths that can penetrate tissue relatively well and for other wavelengths that tend to be significantly absorbed in tissue. A wide variety of other driving powers and driving methodologies can be used in various embodiments. The driver 811 can be synchronized with other parts

Clean Specification

of the sensor 801 to minimize or reduce jitter in the timing of pulses of optical radiation emitted from the emitter 804. In some embodiments, the driver 811 is capable of driving the emitter 804 to emit optical radiation in a pattern that varies by less than about 10 parts-per-million.

[0059] The detector 806 captures and measures light from the tissue measurement site 102. For example, the detector 806 can capture and measure light transmitted from the emitter 804 that has been attenuated or reflected from the tissue at the measurement site 102. The detector 806 can output a detector signal 107 responsive to the light captured and measured. The detector 806 can be implemented using one or more photodiodes, phototransistors, or the like. In some embodiments, a detector 806 is implemented in detector package to capture and measure light from the tissue measurement site 102 of the patient. The detector package can include a photodiode chip mounted to leads and enclosed in an encapsulant. In some embodiments, the dimensions of the detector package are approximately 2 square centimeters. In other embodiments, the dimensions of the detector package are approximately 1.5 centimeters in width and approximately 2 centimeters in length.

[0060] The front-end interface 808 provides an interface that adapts the output of the detectors 806, which is responsive to desired physiological parameters. For example, the front-end interface 808 can adapt the signal 807 received from the detector 806 into a form that can be processed by the monitor 809, for example, by a signal processor 810 in the monitor 809. The front-end interface 808 can have its components assembled in the sensor 801, in the monitor 809, in a connecting cabling (if used), in combinations of the same, or the like. The location of the front-end interface 808 can be chosen based on various factors including space desired for components, desired noise reductions or limits, desired heat reductions or limits, and the like.

[0061] The front-end interface 808 can be coupled to the detector 806 and to the signal processor 810 using a bus, wire, electrical or optical cable, flex circuit, or some other form of signal connection. The front-end interface 808 can also be at least partially integrated with various components, such as the detectors 806. For

Clean Specification

example, the front-end interface 808 can include one or more integrated circuits that are on the same circuit board as the detector 806. Other configurations can also be used.

[0062] As shown in FIG. 8, the monitor 909 can include the signal processor 810 and a user interface, such as a display 812. The monitor 809 can also include optional outputs alone or in combination with the display 812, such as a storage device 814 and a network interface 816. In an embodiment, the signal processor 810 includes processing logic that determines measurements for desired analytes based on the signals received from the detector 806. The signal processor 810 can be implemented using one or more microprocessors or sub-processors (*e.g.*, cores), digital signal processors, application specific integrated circuits (ASICs), field programmable gate arrays (FPGAs), combinations of the same, and the like.

[0063] The signal processor 810 can provide various signals that control the operation of the sensor 801. For example, the signal processor 810 can provide an emitter control signal to the driver 811. This control signal can be useful in order to synchronize, minimize, or reduce jitter in the timing of pulses emitted from the emitter 804. Accordingly, this control signal can be useful in order to cause optical radiation pulses emitted from the emitter 804 to follow a precise timing and consistent pattern. For example, when a transimpedance-based front-end interface 808 is used, the control signal from the signal processor 810 can provide synchronization with an analog-to-digital converter (ADC) in order to avoid aliasing, cross-talk, and the like. As also shown, an optional memory 813 can be included in the front-end interface 808 and/or in the signal processor 810. This memory 813 can serve as a buffer or storage location for the front-end interface 808 and/or the signal processor 810, among other uses.

[0064] The user interface 812 can provide an output, *e.g.*, on a display, for presentation to a user of the pulse oximetry system 800. The user interface 812 can be implemented as a touch-screen display, a liquid crystal display (LCD), an organic LED display, or the like. In alternative embodiments, the pulse oximetry system 800

Clean Specification

can be provided without a user interface 812 and can simply provide an output signal to a separate display or system.

[0065] The storage device 814 and a network interface 816 represent other optional output connections that can be included in the monitor 809. The storage device 814 can include any computer-readable medium, such as a memory device, hard disk storage, EEPROM, flash drive, or the like. The various software and/or firmware applications can be stored in the storage device 814, which can be executed by the signal processor 810 or another processor of the monitor 809. The network interface 816 can be a serial bus port (RS-232/RS-485), a Universal Serial Bus (USB) port, an Ethernet port, a wireless interface (*e.g.*, WiFi such as any 802.1x interface, including an internal wireless card), or other suitable communication device(s) that allows the monitor 809 to communicate and share data with other devices. The monitor 809 can also include various other components not shown, such as a microprocessor, graphics processor, or controller to output the user interface 812, to control data communications, to compute data trending, or to perform other operations.

[0066] Although not shown in the depicted embodiment, the pulse oximetry system 800 can include various other components or can be configured in different ways. For example, the sensor 801 can have both the emitter 804 and detector 806 on the same side of the tissue measurement site 102 and use reflectance to measure analytes.

[0067] Although the foregoing disclosure has been described in terms of certain preferred embodiments, many other variations than those described herein will be apparent to those of ordinary skill in the art.

[0068] Conditional language used herein, such as, among others, "can," "might," "may," "*e.g.*," and the like, unless specifically stated otherwise, or otherwise understood within the context as used, is generally intended to convey that certain embodiments include, while other embodiments do not include, certain features, elements and/or states. Thus, such conditional language is not generally intended to imply that features, elements and/or states are in any way required for one or more embodiments or that one or more embodiments necessarily include logic for

Clean Specification

deciding, with or without author input or prompting, whether these features, elements and/or states are included or are to be performed in any particular embodiment. The terms "comprising," "including," "having," and the like are synonymous and are used inclusively, in an open-ended fashion, and do not exclude additional elements, features, acts, operations, and so forth. Also, the term "or" is used in its inclusive sense (and not in its exclusive sense) so that when used, for example, to connect a list of elements, the term "or" means one, some, or all of the elements in the list. Further, the term "each," as used herein, in addition to having its ordinary meaning, can mean any subset of a set of elements to which the term "each" is applied.

[0069] While the above detailed description has shown, described, and pointed out novel features as applied to various embodiments, it will be understood that various omissions, substitutions, and changes in the form and details of the systems, devices or algorithms illustrated can be made without departing from the spirit of the disclosure. As will be recognized, certain embodiments of the disclosure described herein can be embodied within a form that does not provide all of the features and benefits set forth herein, as some features can be used or practiced separately from others.

[0070] The term "and/or" herein has its broadest, least limiting meaning which is the disclosure includes A alone, B alone, both A and B together, or A or B alternatively, but does not require both A and B or require one of A or one of B. As used herein, the phrase "at least one of" A, B, "and" C should be construed to mean a logical A or B or C, using a non-exclusive logical or.

[0071] The apparatuses and methods described herein may be implemented by one or more computer programs executed by one or more processors. The computer programs include processor-executable instructions that are stored on a non-transitory tangible computer readable medium. The computer programs may also include stored data. Non-limiting examples of the non-transitory tangible computer readable medium are nonvolatile memory, magnetic storage, and optical storage. Although the foregoing disclosure has been described in terms of certain preferred embodiments, other embodiments will be apparent to those of

Clean Specification

ordinary skill in the art from the disclosure herein. Additionally, other combinations, omissions, substitutions and modifications will be apparent to the skilled artisan in view of the disclosure herein. Accordingly, the present invention is not intended to be limited by the description of the preferred embodiments, but is to be defined by reference to claims.

[0072] Additionally, all publications, patents, and patent applications mentioned in this specification are herein incorporated by reference to the same extent as if each individual publication, patent, or patent application were specifically and individually indicated to be incorporated by reference.

Electronic Acknowledgement Receipt	
EFS ID:	26865705
Application Number:	15195199
International Application Number:	
Confirmation Number:	3453
Title of Invention:	ADVANCED PULSE OXIMETRY SENSOR
First Named Inventor/Applicant Name:	Ammar Al-Ali
Customer Number:	64735
Filer:	Jarom D. Kesler/Kealani Aguon
Filer Authorized By:	Jarom D. Kesler
Attorney Docket Number:	MASIMO.1007A
Receipt Date:	08-SEP-2016
Filing Date:	28-JUN-2016
Time Stamp:	14:13:24
Application Type:	Utility under 35 USC 111(a)

Payment information:

Submitted with Payment	no
------------------------	----

File Listing:

Document Number	Document Description	File Name	File Size(Bytes)/ Message Digest	Multi Part /.zip	Pages (if appl.)
1		MASIMO_1007A_PrelimAmend.pdf	28519 ba98ee1b2bd09887afdadc573ff77eeb4d6c134	yes	4

Multipart Description/PDF files in .zip description					
Document Description			Start	End	
Preliminary Amendment			1	1	
Specification			2	3	
Applicant Arguments/Remarks Made in an Amendment			4	4	
Warnings:					
Information:					
2	Specification	MASIMO_1007A_MarkedSpec.pdf	154616	no	24
			1cbb367dbbf6103e5b969d461bc84678d1f22ec		
Warnings:					
Information:					
3	Specification	MASIMO_1007A_CleanSpec.pdf	153189	no	24
			2985333c01cf33a7b9f9c2d145022f4b0fe0b4ca		
Warnings:					
Information:					
Total Files Size (in bytes):			336324		
<p>This Acknowledgement Receipt evidences receipt on the noted date by the USPTO of the indicated documents, characterized by the applicant, and including page counts, where applicable. It serves as evidence of receipt similar to a Post Card, as described in MPEP 503.</p> <p><u>New Applications Under 35 U.S.C. 111</u> If a new application is being filed and the application includes the necessary components for a filing date (see 37 CFR 1.53(b)-(d) and MPEP 506), a Filing Receipt (37 CFR 1.54) will be issued in due course and the date shown on this Acknowledgement Receipt will establish the filing date of the application.</p> <p><u>National Stage of an International Application under 35 U.S.C. 371</u> If a timely submission to enter the national stage of an international application is compliant with the conditions of 35 U.S.C. 371 and other applicable requirements a Form PCT/DO/EO/903 indicating acceptance of the application as a national stage submission under 35 U.S.C. 371 will be issued in addition to the Filing Receipt, in due course.</p> <p><u>New International Application Filed with the USPTO as a Receiving Office</u> If a new international application is being filed and the international application includes the necessary components for an international filing date (see PCT Article 11 and MPEP 1810), a Notification of the International Application Number and of the International Filing Date (Form PCT/RO/105) will be issued in due course, subject to prescriptions concerning national security, and the date shown on this Acknowledgement Receipt will establish the international filing date of the application.</p>					

Under the Paperwork Reduction Act of 1995, no persons are required to respond to a collection of information unless it displays a valid OMB control number.

PATENT APPLICATION FEE DETERMINATION RECORD Substitute for Form PTO-875	Application or Docket Number 15/195,199	Filing Date 06/28/2016	<input type="checkbox"/> To be Mailed
---	---	----------------------------------	---------------------------------------

ENTITY: LARGE SMALL MICRO

APPLICATION AS FILED – PART I

FOR	NUMBER FILED (Column 1)	NUMBER EXTRA (Column 2)	RATE (\$)	FEE (\$)
<input type="checkbox"/> BASIC FEE (37 CFR 1.16(a), (b), or (c))	N/A	N/A	N/A	
<input type="checkbox"/> SEARCH FEE (37 CFR 1.16(k), (j), or (m))	N/A	N/A	N/A	
<input type="checkbox"/> EXAMINATION FEE (37 CFR 1.16(o), (p), or (q))	N/A	N/A	N/A	
TOTAL CLAIMS (37 CFR 1.16(i))	minus 20 =	*	X \$ =	
INDEPENDENT CLAIMS (37 CFR 1.16(h))	minus 3 =	*	X \$ =	
<input type="checkbox"/> APPLICATION SIZE FEE (37 CFR 1.16(s))	If the specification and drawings exceed 100 sheets of paper, the application size fee due is \$310 (\$155 for small entity) for each additional 50 sheets or fraction thereof. See 35 U.S.C. 41(a)(1)(G) and 37 CFR 1.16(s).			
<input type="checkbox"/> MULTIPLE DEPENDENT CLAIM PRESENT (37 CFR 1.16(j))				
* If the difference in column 1 is less than zero, enter "0" in column 2.			TOTAL	

APPLICATION AS AMENDED – PART II

AMENDMENT	DATE (Column 1)	CLAIMS REMAINING AFTER AMENDMENT (Column 2)	MINUS	HIGHEST NUMBER PREVIOUSLY PAID FOR (Column 3)	PRESENT EXTRA	RATE (\$)	ADDITIONAL FEE (\$)	
	09/08/2016							
	Total (37 CFR 1.16(j))	* 36	Minus	** 36	= 0	X \$80 =	0	
	Independent (37 CFR 1.16(h))	* 4	Minus	***4	= 0	X \$420 =	0	
	<input type="checkbox"/> Application Size Fee (37 CFR 1.16(s))							
	<input type="checkbox"/> FIRST PRESENTATION OF MULTIPLE DEPENDENT CLAIM (37 CFR 1.16(j))							
						TOTAL ADD'L FEE	0	

AMENDMENT	DATE (Column 1)	CLAIMS REMAINING AFTER AMENDMENT (Column 2)	MINUS	HIGHEST NUMBER PREVIOUSLY PAID FOR (Column 3)	PRESENT EXTRA	RATE (\$)	ADDITIONAL FEE (\$)	
	Total (37 CFR 1.16(i))	*	Minus	**	=	X \$ =		
	Independent (37 CFR 1.16(h))	*	Minus	***	=	X \$ =		
	<input type="checkbox"/> Application Size Fee (37 CFR 1.16(s))							
	<input type="checkbox"/> FIRST PRESENTATION OF MULTIPLE DEPENDENT CLAIM (37 CFR 1.16(j))							
						TOTAL ADD'L FEE		

* If the entry in column 1 is less than the entry in column 2, write "0" in column 3.
 ** If the "Highest Number Previously Paid For" IN THIS SPACE is less than 20, enter "20".
 *** If the "Highest Number Previously Paid For" IN THIS SPACE is less than 3, enter "3".
 The "Highest Number Previously Paid For" (Total or Independent) is the highest number found in the appropriate box in column 1.

LIE
 /JACQUELYN WILLIAMS/

This collection of information is required by 37 CFR 1.16. The information is required to obtain or retain a benefit by the public which is to file (and by the USPTO to process) an application. Confidentiality is governed by 35 U.S.C. 122 and 37 CFR 1.14. This collection is estimated to take 12 minutes to complete, including gathering, preparing, and submitting the completed application form to the USPTO. Time will vary depending upon the individual case. Any comments on the amount of time you require to complete this form and/or suggestions for reducing this burden, should be sent to the Chief Information Officer, U.S. Patent and Trademark Office, U.S. Department of Commerce, P.O. Box 1450, Alexandria, VA 22313-1450. DO NOT SEND FEES OR COMPLETED FORMS TO THIS ADDRESS. **SEND TO: Commissioner for Patents, P.O. Box 1450, Alexandria, VA 22313-1450.**
 If you need assistance in completing the form, call 1-800-PTO-9199 and select option 2.



UNITED STATES PATENT AND TRADEMARK OFFICE

UNITED STATES DEPARTMENT OF COMMERCE
 United States Patent and Trademark Office
 Address: COMMISSIONER FOR PATENTS
 P.O. Box 1450
 Alexandria, Virginia 22313-1450
 www.uspto.gov

APPLICATION NUMBER	FILING OR 371(C) DATE	FIRST NAMED APPLICANT	ATTY. DOCKET NO./TITLE
15/195,199	06/28/2016	Ammar Al-Ali	MASIMO.1007A

CONFIRMATION NO. 3453

PUBLICATION NOTICE



64735
 KNOBBE, MARTENS, OLSON & BEAR, LLP
 MASIMO CORPORATION (MASIMO)
 2040 MAIN STREET
 FOURTEENTH FLOOR
 IRVINE, CA 92614

Title:ADVANCED PULSE OXIMETRY SENSOR

Publication No.US-2017-0000394-A1

Publication Date:01/05/2017

NOTICE OF PUBLICATION OF APPLICATION

The above-identified application will be electronically published as a patent application publication pursuant to 37 CFR 1.211, et seq. The patent application publication number and publication date are set forth above.

The publication may be accessed through the USPTO's publically available Searchable Databases via the Internet at www.uspto.gov. The direct link to access the publication is currently <http://www.uspto.gov/patft/>.

The publication process established by the Office does not provide for mailing a copy of the publication to applicant. A copy of the publication may be obtained from the Office upon payment of the appropriate fee set forth in 37 CFR 1.19(a)(1). Orders for copies of patent application publications are handled by the USPTO's Office of Public Records. The Office of Public Records can be reached by telephone at (571) 272-3150 or (800) 972-6382, by facsimile at (571) 273-3250, by mail addressed to the United States Patent and Trademark Office, Office of Public Records, Alexandria, VA 22313-1450 or via the Internet.

In addition, information on the status of the application, including the mailing date of Office actions and the dates of receipt of correspondence filed in the Office, may also be accessed via the Internet through the Patent Electronic Business Center at www.uspto.gov using the public side of the Patent Application Information and Retrieval (PAIR) system. The direct link to access this status information is currently <http://pair.uspto.gov/>. Prior to publication, such status information is confidential and may only be obtained by applicant using the private side of PAIR.

Further assistance in electronically accessing the publication, or about PAIR, is available by calling the Patent Electronic Business Center at 1-866-217-9197.

Office of Data Management, Application Assistance Unit (571) 272-4000, or (571) 272-4200, or 1-888-786-0101



UNITED STATES PATENT AND TRADEMARK OFFICE

UNITED STATES DEPARTMENT OF COMMERCE
 United States Patent and Trademark Office
 Address: COMMISSIONER FOR PATENTS
 P.O. Box 1450
 Alexandria, Virginia 22313-1450
 www.uspto.gov

APPLICATION NO.	FILING DATE	FIRST NAMED INVENTOR	ATTORNEY DOCKET NO.	CONFIRMATION NO.
15/195,199	06/28/2016	Ammar Al-Ali	MAS.1007A	3453
64735	7590	09/28/2018	EXAMINER	
KNOBBE, MARTENS, OLSON & BEAR, LLP MASIMO CORPORATION (MASIMO) 2040 MAIN STREET FOURTEENTH FLOOR IRVINE, CA 92614			FARDANESH, MARJAN	
			ART UNIT	PAPER NUMBER
			3735	
			NOTIFICATION DATE	DELIVERY MODE
			09/28/2018	ELECTRONIC

Please find below and/or attached an Office communication concerning this application or proceeding.

The time period for reply, if any, is set in the attached communication.

Notice of the Office communication was sent electronically on above-indicated "Notification Date" to the following e-mail address(es):

jayna.cartee@knobbe.com
 efilng@knobbe.com

Office Action Summary	Application No. 15/195,199	Applicant(s) AL-ALI ET AL.	
	Examiner MARJAN FARDANESH	Art Unit 3735	AIA (First Inventor to File) Status Yes

-- The MAILING DATE of this communication appears on the cover sheet with the correspondence address --

Period for Reply

A SHORTENED STATUTORY PERIOD FOR REPLY IS SET TO EXPIRE 3 MONTHS FROM THE MAILING DATE OF THIS COMMUNICATION.

- Extensions of time may be available under the provisions of 37 CFR 1.136(a). In no event, however, may a reply be timely filed after SIX (6) MONTHS from the mailing date of this communication.
- If NO period for reply is specified above, the maximum statutory period will apply and will expire SIX (6) MONTHS from the mailing date of this communication.
- Failure to reply within the set or extended period for reply will, by statute, cause the application to become ABANDONED (35 U.S.C. § 133). Any reply received by the Office later than three months after the mailing date of this communication, even if timely filed, may reduce any earned patent term adjustment. See 37 CFR 1.704(b).

Status

- 1) Responsive to communication(s) filed on _____.
 A declaration(s)/affidavit(s) under **37 CFR 1.130(b)** was/were filed on _____.
- 2a) This action is **FINAL**. 2b) This action is non-final.
- 3) An election was made by the applicant in response to a restriction requirement set forth during the interview on _____; the restriction requirement and election have been incorporated into this action.
- 4) Since this application is in condition for allowance except for formal matters, prosecution as to the merits is closed in accordance with the practice under *Ex parte Quayle*, 1935 C.D. 11, 453 O.G. 213.

Disposition of Claims*

- 5) Claim(s) _____ is/are pending in the application.
5a) Of the above claim(s) _____ is/are withdrawn from consideration.
- 6) Claim(s) _____ is/are allowed.
- 7) Claim(s) 1-36 is/are rejected.
- 8) Claim(s) _____ is/are objected to.
- 9) Claim(s) _____ are subject to restriction and/or election requirement.

* If any claims have been determined allowable, you may be eligible to benefit from the **Patent Prosecution Highway** program at a participating intellectual property office for the corresponding application. For more information, please see http://www.uspto.gov/patents/init_events/pph/index.jsp or send an inquiry to PPHfeedback@uspto.gov.

Application Papers

- 10) The specification is objected to by the Examiner.
- 11) The drawing(s) filed on 06/28/2016 is/are: a) accepted or b) objected to by the Examiner.
Applicant may not request that any objection to the drawing(s) be held in abeyance. See 37 CFR 1.85(a).
Replacement drawing sheet(s) including the correction is required if the drawing(s) is objected to. See 37 CFR 1.121(d).

Priority under 35 U.S.C. § 119

- 12) Acknowledgment is made of a claim for foreign priority under 35 U.S.C. § 119(a)-(d) or (f).

Certified copies:

- a) All b) Some** c) None of the:
 - 1. Certified copies of the priority documents have been received.
 - 2. Certified copies of the priority documents have been received in Application No. _____.
 - 3. Copies of the certified copies of the priority documents have been received in this National Stage application from the International Bureau (PCT Rule 17.2(a)).

** See the attached detailed Office action for a list of the certified copies not received.

Attachment(s)

- 1) Notice of References Cited (PTO-892)
- 2) Information Disclosure Statement(s) (PTO/SB/08a and/or PTO/SB/08b)
Paper No(s)/Mail Date 06/28/2016
- 3) Interview Summary (PTO-413)
Paper No(s)/Mail Date _____.
- 4) Other: _____.

Application/Control Number: 15/195,199
Art Unit: 3735

Page 2

DETAILED ACTION

Notice of Pre-AIA or AIA Status

1. The present application, filed on or after March 16, 2013, is being examined under the first inventor to file provisions of the AIA.

Status of Claims

2. Claim(s) 1-36 is/are originally presented for examination.

Priority

3. Applicant's claim for the benefit of priority under 35 U.S.C. 119(e) to provisional application(s), 62/188,430 filed 07/02/2015, is acknowledged.

Information Disclosure Statement

4. The information disclosure statement (IDS) document(s) submitted on 06/28/2016 is/are in compliance with the provisions of 37 C.F.R. 1.97. Accordingly, the IDS document(s) have been fully considered by the examiner.

Claim Objections

5. Applicant is advised that claim 26 are duplicate of claim 1. When two claims in an application are duplicates or else are so close in content that they both cover the same thing, despite a slight difference in wording, it is proper after allowing one claim to object to the other as being a substantial duplicate of the allowed claim. See MPEP § 706.03(k). Claims 1 and 36 are indistinguishable. Claim 26 fails to positively claim structures different than positively claimed structures of claim 1. Further, claim 26 fails

APL_MAS_ITC_00557102

PAGE 143 OF 530

**MASIMO 2057
Apple v. Masimo
IPR2022-01291**

Application/Control Number: 15/195,199
 Art Unit: 3735

Page 3

to disclose two wavelengths or suitable wavelengths for pulse oximeter that would tie the emitter to the preamble.

Claim Rejections - 35 USC § 112

6. The following is a quotation of 35 U.S.C. 112(b):

(b) CONCLUSION.—The specification shall conclude with one or more claims particularly pointing out and distinctly claiming the subject matter which the inventor or a joint inventor regards as the invention.

The following is a quotation of 35 U.S.C. 112 (pre-AIA), second paragraph:

The specification shall conclude with one or more claims particularly pointing out and distinctly claiming the subject matter which the applicant regards as his invention.

7. Claim 32 rejected under 35 U.S.C. 112(b) or 35 U.S.C. 112 (pre-AIA), second paragraph, as being indefinite for failing to particularly point out and distinctly claim the subject matter which the inventor or a joint inventor, or for pre-AIA the applicant regards as the invention.

8. Claim 32 rejected under 35 U.S.C. 112(b) or 35 U.S.C. 112 (pre-AIA), second paragraph, as being incomplete for omitting essential elements, such omission amounting to a gap between the elements. See MPEP § 2172.01. The omitted elements are: Claim 32 discloses a detector configured to detect the emitted spread light. However, claim 32 fails to disclose a diffuser which receives, spreads and emits the spread light.

Claim Rejections - 35 USC § 102

9. The following is a quotation of the appropriate paragraphs of 35 U.S.C. 102 that form the basis for the rejections under this section made in this Office action:

A person shall be entitled to a patent unless –

Application/Control Number: 15/195,199
Art Unit: 3735

Page 4

(a)(1) the claimed invention was patented, described in a printed publication, or in public use, on sale or otherwise available to the public before the effective filing date of the claimed invention.

10. Claim(s) 1,3,4,6,7,9-14,18,,20,23,24, 26,28,29 is/are rejected under 35 U.S.C. 102b as being anticipated by Chin et al. (USPN 6,343,223).

Regarding claims 1, 18, 26, chin et al. discloses method and an optical physiological measurement system (figure 7B) comprising: an emitter which emits light of a wavelength (figure 7B, emitter 176, Col.8 lines 20-50); a diffuser which receives, spreads and emits the spread light, wherein the emitted spread light is directed at a tissue measurement site of a patient (diffuser 180. Figure 7B Col.8 lines 20-50); and a detector (detector 178, figure 7B, Col.8 lines 20-50) configured to detect the emitted light after attenuation by tissue of the patient, the detector further configured to transmit a signal responsive to the detected light (Col.8 lines 20-50).

Regarding claims 3, 20, 28, Chin et al. discloses a processor configured to receive the transmitted signal responsive to the detected light and to determine a physiological parameter (Col.4 lines 26-44).

Regarding claim 4, chin et al. discloses that the parameter is arterial oxygen saturation (oximeters measure oxygen saturation, Col.1 lines 17-39, Col.8 lines 50-63).

Regarding claims 6 and 23, chin et al. discloses that the diffuser emits the spread light with a substantially uniform intensity profile (diffuser 180. Figure 7B Col.8 lines 20-50).

Application/Control Number: 15/195,199
Art Unit: 3735

Page 5

Regarding claims 7, 24, 29, Chin et al. discloses that the diffuser defines a surface area shape by which the emitted spread light is distributed onto a surface of the tissue measurement site (figure 7B).

Regarding claim 9, chin et al. discloses that the surface area shape is rectangular (figure 7B).

Regarding claim 10, Chin et al. discloses that the rectangular surface area shape has dimensions within a range of approximately 0.25 cm to 3 cm in width and a range of approximately 1 cm to 6 cm in length (diffuser 180. Figure 7B Col.8 lines 20-50).

Regarding claim 11, Chin et al. discloses that the rectangular surface area shape has dimensions in the range of approximately 0.1 cm to 2 cm in width and approximately 0.5 cm to 5 cm in length (diffuser 180. Figure 7B Col.8 lines 20-50).

Regarding claim 12, Chin et al. discloses that the rectangular surface area shape has dimensions of approximately 1 centimeter in width and approximately 1.5 centimeters in length (diffuser 180. Figure 7B Col.8 lines 20-50).

Regarding claim 13, Chin et al. discloses that the surface area shape is square (diffuser 180. Figure 7B Col.8 lines 20-50).

Regarding claim 14, Chin et al. discloses that the square surface area shape has dimensions in the range of approximately 0.25 cm² to 10 cm² (diffuser 180. Figure 7B Col.8 lines 20-50).

11. Claim(s) 1-2, 5-9, 15-18-19, 21-27, 29, 30-36 is/are rejected under 35 U.S.C. 102b as being anticipated by Spycher et al. (USPN 2004/0114783).

Application/Control Number: 15/195,199
Art Unit: 3735

Page 6

Regarding claims 1, 18, 26, Spycher et al. discloses method and an optical physiological measurement system (figure 1, [0053]) comprising: an emitter which emits light of a wavelength (figure 1, light source 8, [0040], [0053]); a diffuser which receives, spreads and emits the spread light, wherein the emitted spread light is directed at a tissue measurement site of a patient (transparent body made of glass reads on diffuser, [0039], figure 1 element 1); and a detector (detector 22 figure 1, [0043]) configured to detect the emitted light after attenuation by tissue of the patient, the detector further configured to transmit a signal responsive to the detected light ([0053]).

Regarding claims 2, 19 and 27, Spycher et al. discloses a concentrator (lens 21 figure 1, [0043]) which receives the spread light after attenuation by tissue of the patient, concentrates the received spread light and emits the concentrated light in the direction of the detector (figure 1, [0043]).

Regarding claims 5 and 22, Spycher et al. discloses that the diffuser comprises at least one of a glass diffuser, ground glass diffuser, a glass bead diffuser, an opal glass diffuser, and an engineered diffuser (transparent body 1 made of glass [0039]).

Regarding claims 6 and 23, Spycher et al. discloses that the diffuser emits the spread light with a substantially uniform intensity profile (figure 1, [0039]).

Regarding claims 7, 24, 29, Spycher et al. discloses that the diffuser defines a surface area shape by which the emitted spread light is distributed onto a surface of the tissue measurement site (figure 1).

Regarding claim 8, Spycher et al. discloses detector filter having a light-absorbing surface facing the tissue measurement site and an opening, the opening

Application/Control Number: 15/195,199
Art Unit: 3735

Page 7

having dimensions, wherein the dimensions of the opening are substantially similar to the defined surface area shape by which the emitted spread light is distributed onto the surface of the tissue measurement site (figure 1, diaphragm 20 reads on filter with opening).

Regarding claim 9, Spycher et al. discloses that the surface area shape is rectangular (figure 1).

Regarding claim 15, Spycher et al. discloses a detector filter comprising a light-absorbing surface facing the tissue measurement site and an opening, the opening having dimensions, wherein the dimensions of the opening are substantially similar to dimensions of the rectangular shape (diaphragm 20 figure 1).

Regarding claims 16, 21 and 25, Spycher et al. discloses that the concentrator comprises at least one of glass, ground glass, glass beads, opal glass, and a compound parabolic concentrator (lens 21 made of glass).

Regarding claim 17, Spycher et al. discloses a detector filter comprising a light-absorbing surface facing the tissue measurement site and an opening, wherein the opening is configured to allow the spread light, after being attenuated by or reflected from the tissue measurement site, to be received by the concentrator (diaphragm 20 reads on filter and lens 21 reads on concentrator, figure 1).

Regarding claim 30, spycher et al. discloses that the detector is further configured to have a detection area corresponding to the defined surface area shape by which the emitted spread light is distributed onto the surface of the tissue measurement site (figure 1).

Application/Control Number: 15/195,199
Art Unit: 3735

Page 8

Regarding claim 31, Spycher et al. discloses that the detector further comprises an array of detectors configured to cover the detection area ([0047]).

Regarding claim 32, Spycher et al. discloses a pulse oximeter sensor ([0053]) comprising: an emitter configured to emit light at a wavelength (figure 1, light source 8, [0040], [0053]); a concentrator which concentrates the emitted light after it has been attenuated by the tissue measurement site (lens 21 figure 1, [0043]); and a detector configured to detect the emitted spread, the spread light having been attenuated by or reflected from the tissue measurement site, the detector further configured to output a signal responsive to the detected light (detector 22 figure 1, [0043]).

Regarding claim 33, Spycher et al. discloses that the detector is further configured to transmit the output signal responsive to the detected light to a processor configured to receive the signal responsive to the detected light and to determine a physiological parameter ([0053]).

Regarding claim 34, Spycher et al. discloses that the concentrator is further configured to define a surface area shape by which the emitted spread light is received from a surface of the tissue measurement site (lens 21, figure 1, [0043]).

Regarding claim 35, Spycher et al. discloses that the concentrator is further configured to have a detection area corresponding to the defined surface area shape by which the emitted spread light is distributed onto the surface of the tissue measurement site (lens 21, figure 1, [0043]).

Application/Control Number: 15/195,199
Art Unit: 3735

Page 9

Regarding claim 36, Spycher et al. discloses that the detector further comprises an array of detectors configured to cover the detection area ([0047]).

Conclusion

Any inquiry concerning this communication or earlier communications from the examiner should be directed to MARJAN FARDANESH whose telephone number is (571)270-5508. The examiner can normally be reached on Monday-Friday 9:30-18:00.

If attempts to reach the examiner by telephone are unsuccessful, the examiner's supervisor, Mallari Patricia can be reached on (571)272-4729. The fax phone number for the organization where this application or proceeding is assigned is 571-273-8300.

Information regarding the status of an application may be obtained from the Patent Application Information Retrieval (PAIR) system. Status information for published applications may be obtained from either Private PAIR or Public PAIR. Status information for unpublished applications is available through Private PAIR only. For more information about the PAIR system, see <http://pair-direct.uspto.gov>. Should you have questions on access to the Private PAIR system, contact the Electronic Business Center (EBC) at 866-217-9197 (toll-free). If you would like assistance from a USPTO Customer Service Representative or access to the automated information system, call 800-786-9199 (IN USA OR CANADA) or 571-272-1000.

/MARJAN FARDANESH/
Examiner, Art Unit 3735

APL_MAS_ITC_00557109

PAGE 150 OF 530

MASIMO 2057
Apple v. Masimo
IPR2022-01291

Notice of References Cited	Application/Control No. 15/195,199	Applicant(s)/Patent Under Reexamination AL-ALI ET AL.	
	Examiner MARJAN FARDANESH	Art Unit 3735	Page 1 of 1

U.S. PATENT DOCUMENTS

*	Document Number Country Code-Number-Kind Code	Date MM-YYYY	Name	CPC Classification	US Classification
*	A US-2004/0114783 A1	06-2004	Spycher, Martin	G06K9/00046	382/124
*	B US-6,343,223 B1	01-2002	Chin; Rodney	A61B5/14552	600/323
C	US-				
D	US-				
E	US-				
F	US-				
G	US-				
H	US-				
I	US-				
J	US-				
K	US-				
L	US-				
M	US-				

FOREIGN PATENT DOCUMENTS

*	Document Number Country Code-Number-Kind Code	Date MM-YYYY	Country	Name	CPC Classification
N					
O					
P					
Q					
R					
S					
T					

NON-PATENT DOCUMENTS

*	Document Number Country Code-Number-Kind Code	Date MM-YYYY	Country	Name	CPC Classification
		Include as applicable: Author, Title Date, Publisher, Edition or Volume, Pertinent Pages)			
U					
V					
W					
X					

*A copy of this reference is not being furnished with this Office action. (See MPEP § 707.05(a).)
Dates in MM-YYYY format are publication dates. Classifications may be US or foreign.

EAST Search History

EAST Search History (Prior Art)

Ref #	Hits	Search Query	DBs	Default Operator	Plurals	Time Stamp
L4	5	("2004/0058311").URPN.	USPAT	OR	OFF	2018/09/19 11:33
L5	355	diffuser same light and (lens) same (detector photodiode photodetector) and A61B5/\$.cpc.	US-PGPUB; USPAT	OR	ON	2018/09/19 11:57
L6	1	"15195199" and filter	US-PGPUB; USPAT	OR	ON	2018/09/19 12:04
L7	1	"20080097172".pn. and lens	US-PGPUB; USPAT	OR	ON	2018/09/19 12:08
L8	6	("2008/0097172").URPN.	USPAT	OR	OFF	2018/09/19 12:18
L9	68	(diaphragm) same (lens) same (detector photodiode photodetector) and A61B5/\$.cpc.	US-PGPUB; USPAT	OR	ON	2018/09/19 12:54
S1	89	operational adj transconductance adj amplifier and A61B5/\$.cpc.	US-PGPUB; USPAT	OR	ON	2018/09/11 11:07
S2	3188	(mobile cell phone telephone cellular) same oximet\$4	US-PGPUB; USPAT	OR	ON	2018/09/11 11:48
S3	0	(mobile cell phone telephone cellular) same oximet\$4 and A661B5/\$.cpc.	US-PGPUB; USPAT	OR	ON	2018/09/11 11:48
S4	1830	(mobile cell phone telephone cellular) same oximet\$4 and A61B5/\$.cpc.	US-PGPUB; USPAT	OR	ON	2018/09/11 11:48
S5	156	(mobile cell phone telephone cellular) same oximet\$4 and A61B5/\$.cpc. and headset	US-PGPUB; USPAT	OR	ON	2018/09/11 11:49
S6	244	(mobile cell phone telephone cellular) same oximet\$4 and A61B5/\$.cpc. and finger same clip	US-PGPUB; USPAT	OR	ON	2018/09/11 11:49
S7	222	(cell phone telephone cellular) same oximet\$4 and A61B5/\$.cpc. and finger same clip	US-PGPUB; USPAT	OR	ON	2018/09/11 11:50
S8	813	(cell phone telephone cellular) and oximet\$4 and A61B5/\$.cpc. and finger same clip	US-PGPUB; USPAT	OR	ON	2018/09/11 12:30
S9	669	(cell-phone cellphone phone telephone cellular) and oximet\$4 and A61B5/\$.cpc. and finger same clip	US-PGPUB; USPAT	OR	ON	2018/09/11 12:31
S10	639	(cell-phone cellphone phone telephone cellular) and wireless\$4 and oximet\$4 and A61B5/\$.cpc. and finger same clip	US-PGPUB; USPAT	OR	ON	2018/09/11 12:31
S11	1	"20020049389".pn.	US-	OR	ON	2018/09/11

EAST Search History

			PGPUB; USPAT			13:42
S12	9	such.in. and radio and transmit\$5	US- PGPUB; USPAT	OR	ON	2018/09/11 13:53
S13	6	such.in. and oximet\$4	US- PGPUB; USPAT	OR	ON	2018/09/11 13:56
S14	2	"20070123756"	US- PGPUB; USPAT	OR	ON	2018/09/11 16:14
S15	1	"20070123756".pn.	US- PGPUB; USPAT	OR	ON	2018/09/11 16:14
S16	1	"20060258928".pn.	US- PGPUB; USPAT	OR	ON	2018/09/11 16:15
S17	0	encircle adj wrist same thenar and A61B5/\$.cpc.	US- PGPUB; USPAT	OR	ON	2018/09/11 16:51
S18	92	encircled\$4 adj wrist and A61B5/\$.cpc.	US- PGPUB; USPAT	OR	ON	2018/09/11 16:51
S19	87	wrist same thenar and A61B5/\$.cpc.	US- PGPUB; USPAT	OR	ON	2018/09/11 16:56
S20	3	("2006/0253167").URPN.	USPAT	OR	OFF	2018/09/11 17:01
S21	3	("2006/0253167").URPN.	US- PGPUB; USPAT	OR	OFF	2018/09/11 17:02
S22	2311	wire with wireless\$4 same transmit\$4 and A61B5/\$.cpc.	US- PGPUB; USPAT	OR	OFF	2018/09/11 18:29
S23	1590	wire with wireless\$4 with transmit\$4 and A61B5/\$.cpc.	US- PGPUB; USPAT	OR	OFF	2018/09/11 18:29
S24	174	wire with wireless\$4 with transmit\$4 and A61B5/1455\$.cpc.	US- PGPUB; USPAT	OR	OFF	2018/09/11 18:31
S25	7	ortner.in. and thenar	US- PGPUB; USPAT	OR	OFF	2018/09/11 18:35
S26	1	"20080097172".pn.	US- PGPUB; USPAT	OR	ON	2018/09/15 11:56
S27	1	("20080097172").PN.	US- PGPUB; USPAT; USOCR	OR	OFF	2018/09/15 11:58
S28	0	"14897412"	USPAT	OR	OFF	2018/09/16 10:13
S29	1	"14897412"	US- PGPUB; USPAT	OR	OFF	2018/09/16 10:14
S30	1	"14897412"	US- PGPUB;	OR	OFF	2018/09/16 10:14

EAST Search History

			USPAT			
S31	60	heat with (light LED) same (marble ceramic) and A61B5/\$.cpc.	US-PGPUB; USPAT	OR	ON	2018/09/16 18:20
S32	29	Peltier same cool\$4 same substrate and A61B5/\$.cpc.	US-PGPUB; USPAT	OR	ON	2018/09/16 18:36
S33	18	Peltier same cool\$4 same (emitter LED) and A61B5/\$.cpc.	US-PGPUB; USPAT	OR	ON	2018/09/16 18:57
S34	251	fardanesh.xa.	US-PGPUB; USPAT	OR	ON	2018/09/16 19:09
S35	2	((("5517987") or ("6519487")).PN.	USPAT; USOCR	OR	OFF	2018/09/16 21:03
S36	1	("20040152961").PN.	US-PGPUB; USPAT; USOCR	OR	OFF	2018/09/17 09:09
S37	0	("11407296").PN.	USPAT; USOCR	OR	OFF	2018/09/17 09:35
S38	1	"14303111" and strain	US-PGPUB; USPAT	OR	OFF	2018/09/17 10:27
S39	3	"12707467"	US-PGPUB; USPAT	OR	OFF	2018/09/17 11:38
S40	2	((("20050033136") or ("20110095756")).PN.	US-PGPUB; USPAT; USOCR	OR	OFF	2018/09/17 11:53
S41	154	(analyte glucose) and (magnet magnetic) and halbach	US-PGPUB; USPAT	OR	ON	2018/09/17 12:02
S42	140	(analyte glucose) and (magnet magnetic) and halbach and (particle nano-particle nanoparticle)	US-PGPUB; USPAT	OR	ON	2018/09/17 12:04
S43	78	(analyte glucose) and (magnet magnetic) and halbach and (particle nano-particle nanoparticle) and (hydrogel expand\$5)	US-PGPUB; USPAT	OR	ON	2018/09/17 12:45
S44	28	fardanesh.xa. and hydrogel	US-PGPUB; USPAT	OR	ON	2018/09/18 12:35
S45	2	"20130245402"	US-PGPUB; USPAT	OR	ON	2018/09/18 12:41
S46	1	"15090608" and fluid adj contact	US-PGPUB; USPAT	OR	ON	2018/09/18 13:51
S47	1	"15195199"	US-PGPUB; USPAT	OR	ON	2018/09/18 14:23
S48	15	((("9351675") or ("9351673") or ("20160143548") or ("20160051205") or ("9341565") or ("9339220") or ("9333316") or ("9326712") or ("201601113527") or ("9323894") or ("20160103598") or	US-PGPUB; USPAT; USOCR	OR	OFF	2018/09/18 15:37

EAST Search History

		("9307928") or ("20160095543") or ("20160095548") or ("9295421") or ("9289167").PN.				
S49	33	diffuser and concentrator and A61B5/\$.cpc.	US-PGPUB; USPAT	OR	OFF	2018/09/18 15:39
S50	93	diffuser same (spread\$4) with light and A61B5/\$.cpc.	US-PGPUB; USPAT	OR	OFF	2018/09/18 15:42
S51	1396	diffuser and A61B5/\$.cpc.	US-PGPUB; USPAT	OR	OFF	2018/09/18 16:55
S52	671	diffuser and A61B5/\$.cpc. and glass	US-PGPUB; USPAT	OR	OFF	2018/09/18 16:55
S53	659	diffuser same (emitter light) and A61B5/\$.cpc. and glass	US-PGPUB; USPAT	OR	ON	2018/09/18 16:55
S54	604	S53 not S50	US-PGPUB; USPAT	OR	ON	2018/09/18 16:56

EAST Search History (Interference)

<This search history is empty>

9/ 19/ 2018 2:35:19 PM
C:\Users\mfardanesh\Desktop\one.wsp

Receipt date: 06/28/2016

15/195,199 - GAU: 3735

PTO/SB/08 Equivalent

INFORMATION DISCLOSURE STATEMENT BY APPLICANT	Application No.	Unknown	
	Filing Date	Herewith	
	First Named Inventor	Ammar Al-Ali	
	Art Unit	Unknown	
<i>(Multiple sheets used when necessary)</i>		Examiner	Unknown
SHEET 1 OF 24		Attorney Docket No.	MASIMO.1007A

U.S. PATENT DOCUMENTS

Examiner Initials	Cite No.	Document Number <i>Number - Kind Code (if known)</i> Example: 1,234,567 B1	Publication Date MM-DD-YYYY	Name of Patentee or Applicant	Pages, Columns, Lines Where Relevant Passages or Relevant Figures Appear
	1	9,351,675	05/31/2016	Al-Ali et al.	
	2	9,351,673	05/31/2016	Diab et al.	
	3	2016/0143548	05/26/2016	Al-Ali	
	4	2016/0051205	02/25/2016	Al-Ali et al.	
	5	9,341,565	05/17/2016	Lamego et al.	
	6	9,339,220	05/17/2016	Lamego et al.	
	7	9,333,316	05/10/2016	Kiani	
	8	D755,392	05/03/2016	Hwang et al.	
	9	9,326,712	05/03/2016	Kiani	
	10	2016/0113527	04/28/2016	Al-Ali et al.	
	11	9,323,894	04/26/2016	Kiani	
	12	2016/0103598	04/14/2016	Al-Ali et al.	
	13	9,307,928	04/12/2016	Al-Ali et al.	
	14	2016/0095548	04/07/2016	Al-Ali et al.	
	15	2016/0095543	04/07/2016	Telfort et al.	
	16	9,295,421	03/29/2016	Kiani et al.	
	17	2016/0081552	03/24/2016	Wojtczuk et al.	
	18	9,289,167	03/22/2016	Diab et al.	
	19	2016/0073967	03/17/2016	Lamego et al.	
	20	2016/0072429	03/10/2016	Kiani et al.	
	21	2016/0066879	03/10/2016	Telfort et al.	
	22	2016/0066824	03/10/2016	Al-Ali et al.	
	23	2016/0066823	03/10/2016	Kind et al.	
	24	9,277,880	03/08/2016	Poeze et al.	
	25	2016/0058347	03/03/2016	Reichgott et al.	
	26	2016/0058338	03/03/2016	Schurman et al.	
	27	9,267,572	02/23/2016	Barker et al.	
	28	2016/0045118	02/18/2016	Kiani	
	29	9,259,185	02/16/2016	Abdul-Hafiz et al.	

Examiner Signature	<u>/MARJAN FARDANESH/</u>	Date Considered	09/18/2018
<p>*Examiner: Initial if reference considered, whether or not citation is in conformance with MPEP 609. Draw line through citation if not in conformance and not considered. Include copy of this form with next communication to applicant.</p>			

T¹ - Place a check mark in this area when an English language Translation is attached.

ALL REFERENCES CONSIDERED EXCEPT WHERE LINED THROUGH. /M.F/

APL_MAS_ITC_00557115

Receipt date: 06/28/2016

15/195,199 - GAU: 3735

PTO/SB/08 Equivalent

INFORMATION DISCLOSURE STATEMENT BY APPLICANT	Application No.	Unknown	
	Filing Date	Herewith	
	First Named Inventor	Ammar Al-Ali	
	Art Unit	Unknown	
<i>(Multiple sheets used when necessary)</i>		Examiner	Unknown
SHEET 2 OF 24		Attorney Docket No.	MASIMO.1007A

U.S. PATENT DOCUMENTS

Examiner Initials	Cite No.	Document Number <i>Number - Kind Code (if known)</i> Example: 1,234,567 B1	Publication Date MM-DD-YYYY	Name of Patentee or Applicant	Pages, Columns, Lines Where Relevant Passages or Relevant Figures Appear
	30	2016/0029933	02/04/2016	Al-Ali et al.	
	31	2016/0029932	02/04/2016	Al-Ali	
	32	9,245,668	01/26/2016	Vo et al.	
	33	9,241,662	01/26/2016	Al-Ali et al.	
	34	2016/0007930	01/14/2016	Weber et al.	
	35	2016/0000362	01/07/2016	Diab et al.	
	36	9,226,696	01/05/2016	Kiani	
	37	2015/0380875	12/31/2015	Coverston et al.	
	38	2015/0374298	12/31/2015	Al-Ali et al.	
	39	2015/0366507	12/24/2015	Blank	
	40	2015/0366472	12/24/2015	Kiani	
	41	9,218,454	12/22/2015	Kiani et al.	
	42	9,211,095	12/15/2015	Al-Ali	
	43	9,211,072	12/15/2015	Kiani	
	44	2015/0359429	12/17/2015	Al-Ali et al.	
	45	2015/0351704	12/20/2015	Kiani et al.	
	46	2015/0351697	12/10/2015	Weber et al.	
	47	9,195,385	11/24/2015	Al-Ali et al.	
	48	9,192,351	11/24/2015	Telfort et al.	
	49	9,192,329	11/24/2015	Al-Ali	
	50	9,192,312	11/24/2015	Al-Ali	
	51	9,186,102	11/17/2015	Bruinsma et al.	
	52	9,176,141	11/03/2015	Al-Ali et al.	
	53	9,167,995	10/27/2015	Lamego et al.	
	54	9,161,713	10/20/2015	Al-Ali et al.	
	55	9,161,696	10/20/2015	Al-Ali et al.	
	56	9,153,121	10/06/2015	Kiani et al.	
	57	9,153,112	10/06/2015	Kiani et al.	
	58	2015/0272514	10/01/2015	Kiani et al.	

Examiner Signature <u>/MARJAN FARDANESH/</u>	Date Considered <u>09/18/2018</u>
<p>*Examiner: Initial if reference considered, whether or not citation is in conformance with MPEP 609. Draw line through citation if not in conformance and not considered. Include copy of this form with next communication to applicant.</p>	

T¹ - Place a check mark in this area when an English language Translation is attached.

ALL REFERENCES CONSIDERED EXCEPT WHERE LINED THROUGH. /M.F/

APL_MAS_ITC_00557116

Receipt date: 06/28/2016

15/195,199 - GAU: 3735

PTO/SB/08 Equivalent

INFORMATION DISCLOSURE STATEMENT BY APPLICANT	Application No.	Unknown	
	Filing Date	Herewith	
	First Named Inventor	Ammar Al-Ali	
	Art Unit	Unknown	
<i>(Multiple sheets used when necessary)</i>		Examiner	Unknown
SHEET 3 OF 24		Attorney Docket No.	MASIMO.1007A

U.S. PATENT DOCUMENTS

Examiner Initials	Cite No.	Document Number <i>Number - Kind Code (if known)</i> Example: 1,234,567 B1	Publication Date MM-DD-YYYY	Name of Patentee or Applicant	Pages, Columns, Lines Where Relevant Passages or Relevant Figures Appear
	59	9,142,117	09/22/2015	Muhsin et al.	
	60	9,138,192	09/22/2015	Weber et al.	
	61	9,138,182	09/22/2015	Al-Ali et al.	
	62	9,138,180	09/22/2015	Coverston et al.	
	63	2015/0257689	09/17/2015	Al-Ali et al.	
	64	9,131,917	09/15/2015	Telfort et al.	
	65	9,131,883	09/15/2015	Al-Ali	
	66	9,131,882	09/15/2015	Al-Ali et al.	
	67	9,131,881	09/15/2015	Diab et al.	
	68	2015/0245794	09/03/2015	Al-Ali	
	69	2015/0245773	09/03/2015	Lamego et al.	
	70	2015/0245793	09/02/2015	Al-Ali et al.	
	71	9,119,595	09/01/2015	Lamego	
	72	2015/0238722	08/27/2015	Al-Ali	
	73	9,113,832	08/25/2015	Al-Ali	
	74	9,113,831	08/25/2015	Al-Ali	
	75	2015/0230755	08/20/2015	Al-Ali et al.	
	76	9,107,626	08/18/2015	Al-Ali et al.	
	77	9,107,625	08/18/2015	Telfort et al.	
	78	9,106,038	08/11/2015	Telfort et al.	
	79	2015/0216459	08/06/2015	Al-Ali et al.	
	80	9,095,316	08/04/2015	Welch et al.	
	81	2015/0208966	07/30/2015	Al-Ali	
	82	2015/0201874	07/23/2015	Diab	
	83	9,084,569	07/21/2015	Weber et al.	
	84	2015/0196237	07/16/2015	Lamego	
	85	9,078,560	07/14/2015	Schurman et al.	
	86	9,072,474	07/07/2015	Al-Ali et al.	
	87	9,066,680	06/30/2015	Al-Ali et al.	

Examiner Signature	<u>/MARJAN FARDANESH/</u>	Date Considered	09/18/2018
<p>*Examiner: Initial if reference considered, whether or not citation is in conformance with MPEP 609. Draw line through citation if not in conformance and not considered. Include copy of this form with next communication to applicant.</p>			

T¹ - Place a check mark in this area when an English language Translation is attached.

ALL REFERENCES CONSIDERED EXCEPT WHERE LINED THROUGH. /M.F/

APL_MAS_ITC_00557117

Receipt date: 06/28/2016

15/195,199 - GAU: 3735

PTO/SB/08 Equivalent

INFORMATION DISCLOSURE STATEMENT BY APPLICANT	Application No.	Unknown	
	Filing Date	Herewith	
	First Named Inventor	Ammar Al-Ali	
	Art Unit	Unknown	
<i>(Multiple sheets used when necessary)</i>		Examiner	Unknown
SHEET 4 OF 24		Attorney Docket No.	MASIMO.1007A

U.S. PATENT DOCUMENTS

Examiner Initials	Cite No.	Document Number <i>Number - Kind Code (if known)</i> Example: 1,234,567 B1	Publication Date MM-DD-YYYY	Name of Patentee or Applicant	Pages, Columns, Lines Where Relevant Passages or Relevant Figures Appear
	88	9,066,666	06/30/2015	Kiani	
	89	9,060,721	06/23/2015	Reichgott et al.	
	90	2015/0165312	06/18/2015	Kiani	
	91	2015/0141781	05/21/2015	Weber et al.	
	92	2015/0140863	05/21/2015	Al-Ali et al.	
	93	9,037,207	05/19/2015	Al-Ali et al.	
	94	2015/0133755	05/14/2015	Smith et al.	
	95	9,028,429	05/12/2015	Telfort et al.	
	96	2015/0126830	5/07/2015	Schurman et al.	
	97	2015/0116076	4/30/2015	Al-Ali et al.	
	98	2015/0112151	04/23/2015	Muhsin et al.	
	99	2015/0106121	04/16/2015	Muhsin et al.	
	100	2015/0101844	04/16/2015	Al-Ali et al.	
	101	2015/0099955	04/09/2015	Al-Ali et al.	
	102	2015/0099951	04/09/2015	Al-Ali et al.	
	103	2015/0099950	04/09/2015	Al-Ali et al.	
	104	2015/0097701	04/09/2015	Al-Ali et al.	
	105	2015/0099324	04/09/2015	Wojtczuk et al.	
	106	8,998,809	04/07/2015	Kiani	
	107	2015/0094546	04/02/2015	Al-Ali	
	108	8,996,085	03/31/2015	Kiani et al.	
	109	2015/0087936	03/26/2015	Al-Ali et al.	
	110	8,989,831	03/24/2015	Al-Ali et al.	
	111	2015/0080754	03/19/2015	Purdon et al.	
	112	8,983,564	03/17/2015	Al-Ali	
	113	8,965,471	02/24/2015	Lamego	
	114	2015/0051462	02/19/2015	Olsen	
	115	2015/0045685	02/12/2015	Al-Ali et al.	
	116	2015/0045637	02/12/2015	Dalvi	

Examiner Signature	<u>/MARJAN FARDANESH/</u>	Date Considered	09/18/2018
<p>*Examiner: Initial if reference considered, whether or not citation is in conformance with MPEP 609. Draw line through citation if not in conformance and not considered. Include copy of this form with next communication to applicant.</p>			

T¹ - Place a check mark in this area when an English language Translation is attached.

ALL REFERENCES CONSIDERED EXCEPT WHERE LINED THROUGH. /M.F/

APL_MAS_ITC_00557118

Receipt date: 06/28/2016

15/195,199 - GAU: 3735

PTO/SB/08 Equivalent

INFORMATION DISCLOSURE STATEMENT BY APPLICANT	Application No.	Unknown	
	Filing Date	Herewith	
	First Named Inventor	Ammar Al-Ali	
	Art Unit	Unknown	
<i>(Multiple sheets used when necessary)</i>		Examiner	Unknown
SHEET 5 OF 24		Attorney Docket No.	MASIMO.1007A

U.S. PATENT DOCUMENTS

Examiner Initials	Cite No.	Document Number <i>Number - Kind Code (if known)</i> Example: 1,234,567 B1	Publication Date MM-DD-YYYY	Name of Patentee or Applicant	Pages, Columns, Lines Where Relevant Passages or Relevant Figures Appear
	117	2015/0038859	02/05/2015	Dalvi et al.	
	118	8,948,835	02/03/2015	Diab	
	119	8,948,834	02/03/2015	Diab et al.	
	120	2015/0032029	01/29/2015	Al-Ali et al.	
	121	8,942,777	01/27/2015	Diab et al.	
	122	2015/0025406	01/22/2015	Al-Ali	
	123	2015/0018650	01/15/2015	Al-Ali et al.	
	124	2015/0012231	01/08/2015	Poeze et al.	
	125	2015/0011907	01/08/2015	Purdon et al.	
	126	8,929,964	01/06/2015	Al-Ali et al.	
	127	2015/0005600	01/01/2015	Blank et al.	
	128	8,922,382	12/30/2014	Al-Ali et al.	
	129	8,921,699	12/30/2014	Al-Ali et al.	
	130	8,920,317	12/30/2014	Al-Ali et al.	
	131	2014/0378784	12/25/2014	Kiani et al.	
	132	2014/0371548	12/28/2014	Al-Ali et al.	
	133	2014/0371632	12/18/2014	Al-Ali et al.	
	134	8,912,909	12/16/2014	Al-Ali et al.	
	135	8,911,377	12/16/2014	Al-Ali	
	136	8,909,310	12/09/2014	Lamego et al.	
	137	2014/0357966	12/04/2014	Al-Ali et al.	
	138	8,897,847	11/25/2014	Al-Ali	
	139	8,892,180	11/18/2014	Weber et al.	
	140	8,888,708	11/18/2014	Diab et al.	
	141	8,888,539	11/18/2014	Al-Ali et al.	
	142	2014/0336481	11/13/2014	Shakespeare et al.	
	143	8,886,271	11/11/2014	Kiani et al.	
	144	2014/0330099	11/06/2014	Al-Ali et al.	
	145	2014/0330098	11/06/2014	Merritt et al.	

Examiner Signature	<u>/MARJAN FARDANESH/</u>	Date Considered	<u>09/18/2018</u>
<p>*Examiner: Initial if reference considered, whether or not citation is in conformance with MPEP 609. Draw line through citation if not in conformance and not considered. Include copy of this form with next communication to applicant.</p>			

T¹ - Place a check mark in this area when an English language Translation is attached.

ALL REFERENCES CONSIDERED EXCEPT WHERE LINED THROUGH. /M.F/

APL_MAS_ITC_00557119

Receipt date: 06/28/2016

15/195,199 - GAU: 3735

PTO/SB/08 Equivalent

INFORMATION DISCLOSURE STATEMENT BY APPLICANT	Application No.	Unknown	
	Filing Date	Herewith	
	First Named Inventor	Ammar Al-Ali	
	Art Unit	Unknown	
<i>(Multiple sheets used when necessary)</i>		Examiner	Unknown
SHEET 6 OF 24		Attorney Docket No.	MASIMO.1007A

U.S. PATENT DOCUMENTS

Examiner Initials	Cite No.	Document Number <i>Number - Kind Code (if known)</i> Example: 1,234,567 B1	Publication Date MM-DD-YYYY	Name of Patentee or Applicant	Pages, Columns, Lines Where Relevant Passages or Relevant Figures Appear
	146	2014/0330092	11/06/2014	Al-Ali et al.	
	147	2014/0323898	10/30/2014	Purdon et al.	
	148	2014/0323897	10/30/2014	Brown et al.	
	149	2014/0323825	10/30/2014	Al-Ali et al.	
	150	8,870,792	10/28/2014	Al-Ali et al.	
	151	2014/0316218	10/23/2014	Purdon et al.	
	152	2014/0316217	10/23/2014	Purdon et al.	
	153	8,868,150	10/21/2014	Al-Ali et al.	
	154	8,868,147	10/21/2014	Stippick et al.	
	155	2014/0316228	10/23/2014	Blank et al.	
	156	8,852,994	10/07/2014	Wojtczuk et al.	
	157	2014/0303520	10/09/2014	Telfort et al.	
	158	8,852,094	10/07/2014	Al-Ali et al.	
	159	8,849,365	09/30/2014	Smith et al.	
	160	8,847,740	09/30/2014	Kiani et al.	
	161	8,845,543	09/30/2014	Diab et al.	
	162	8,840,549	09/23/2014	Al-Ali et al.	
	163	8,831,700	09/09/2014	Schurman et al.	
	164	8,830,449	09/09/2014	Lamego et al.	
	165	2014/0288400	09/25/2014	Diab et al.	
	166	2014/0276115	09/18/2014	Dalvi et al.	
	167	2014/0275881	09/18/2014	Lamego et al.	
	168	2014/0275872	09/18/2014	Merritt et al.	
	169	2014/0275871	09/18/2014	Lamego et al.	
	170	2014/0275835	09/18/2014	Lamego et al.	
	171	2014/0275808	09/18/2014	Poeze et al.	
	172	8,821,415	09/02/2014	Al-Ali et al.	
	173	2014/0266790	09/18/2014	Al-Ali et al.	
	174	8,821,397	09/02/2014	Al-Ali et al.	

Examiner Signature	<u>/MARJAN FARDANESH/</u>	Date Considered	09/18/2018
<p>*Examiner: Initial if reference considered, whether or not citation is in conformance with MPEP 609. Draw line through citation if not in conformance and not considered. Include copy of this form with next communication to applicant.</p>			

T¹ - Place a check mark in this area when an English language Translation is attached.

ALL REFERENCES CONSIDERED EXCEPT WHERE LINED THROUGH. /M.F/

APL_MAS_ITC_00557120

Receipt date: 06/28/2016

15/195,199 - GAU: 3735

PTO/SB/08 Equivalent

INFORMATION DISCLOSURE STATEMENT BY APPLICANT	Application No.	Unknown	
	Filing Date	Herewith	
	First Named Inventor	Ammar Al-Ali	
	Art Unit	Unknown	
<i>(Multiple sheets used when necessary)</i>		Examiner	Unknown
SHEET 7 OF 24		Attorney Docket No.	MASIMO.1007A

U.S. PATENT DOCUMENTS					
Examiner Initials	Cite No.	Document Number Number - Kind Code (if known) Example: 1,234,567 B1	Publication Date MM-DD-YYYY	Name of Patentee or Applicant	Pages, Columns, Lines Where Relevant Passages or Relevant Figures Appear
	175	8,801,613	08/12/2014	Al-Ali et al.	
	176	8,790,268	07/29/2014	Al-Ali	
	177	8,788,003	07/22/2014	Schurman et al.	
	178	8,781,549	07/15/2014	Al-Ali et al.	
	179	8,781,544	07/15/2014	Al-Ali et al.	
	180	2014/0213864	07/31/2014	Abdul-Hafiz et al.	
	181	8,781,543	07/15/2014	Diab et al.	
	182	2014/0206963	07/24/2014	Al-Ali	
	183	8,777,634	07/15/2014	Kiani et al.	
	184	8,771,204	07/08/2014	Telfort et al.	
	185	2014/0187973	07/03/2014	Brown et al.	
	186	2014/0194766	07/10/2014	Al-Ali et al.	
	187	8,768,423	07/01/2014	Shakespeare et al.	
	188	8,764,671	07/01/2014	Kiani	
	189	2014/0180160	06/26/2014	Brown et al.	
	190	8,761,850	06/24/2014	Lamego	
	191	8,755,872	06/17/2014	Marinow	
	192	8,755,856	06/17/2014	Diab et al.	
	193	2014/0180154	06/26/2014	Sierra et al.	
	194	2014/0180038	06/26/2014	Kiani	
	195	8,755,535	06/17/2014	Telfort et al.	
	196	2014/0171763	06/19/2014	Diab	
	197	2014/0166076	06/19/2014	Kiani et al.	
	198	8,754,776	06/17/2014	Poeze et al.	
	199	2014/0163402	06/12/2014	Lamego et al.	
	200	2014/0163344	06/12/2014	Al-Ali	
	201	8,740,792	06/03/2014	Kiani et al.	
	202	8,723,677	05/13/2014	Kiani	
	203	8,721,542	05/13/2014	Al-Ali et al.	

Examiner Signature /MARJAN FARDANESH/	Date Considered 09/18/2018
<p>*Examiner: Initial if reference considered, whether or not citation is in conformance with MPEP 609. Draw line through citation if not in conformance and not considered. Include copy of this form with next communication to applicant.</p>	

T¹ - Place a check mark in this area when an English language Translation is attached.

ALL REFERENCES CONSIDERED EXCEPT WHERE LINED THROUGH. /M.F/

APL_MAS_ITC_00557121

Receipt date: 06/28/2016

15/195,199 - GAU: 3735

PTO/SB/08 Equivalent

INFORMATION DISCLOSURE STATEMENT BY APPLICANT	Application No.	Unknown	
	Filing Date	Herewith	
	First Named Inventor	Ammar Al-Ali	
	Art Unit	Unknown	
<i>(Multiple sheets used when necessary)</i>		Examiner	Unknown
SHEET 8 OF 24		Attorney Docket No.	MASIMO.1007A

U.S. PATENT DOCUMENTS

Examiner Initials	Cite No.	Document Number <i>Number - Kind Code (if known)</i> Example: 1,234,567 B1	Publication Date MM-DD-YYYY	Name of Patentee or Applicant	Pages, Columns, Lines Where Relevant Passages or Relevant Figures Appear
	204	8,721,541	05/13/2014	Al-Ali et al.	
	205	2014/0142401	05/22/2014	Al-Ali et al.	
	206	8,720,249	05/13/2014	Al-Ali	
	207	2014/0135588	05/15/2014	Al-Ali et al.	
	208	8,718,738	05/06/2014	Blank et al.	
	209	2014/0129702	05/08/2014	Lamego et al.	
	210	2014/0127137	05/08/2014	Bellott et al.	
	211	8,718,737	05/06/2014	Diab et al.	
	212	8,718,735	05/06/2014	Lamego et al.	
	213	2014/0121483	05/01/2014	Kiani	
	214	2014/0121482	05/01/2014	Merritt et al.	
	215	2014/0120564	05/01/2014	Workman et al.	
	216	8,715,206	05/06/2014	Telfort et al.	
	217	8,712,494	04/29/2014	MacNeish, III et al.	
	218	8,706,179	04/22/2014	Parker	
	219	8,702,627	04/22/2014	Telfort et al.	
	220	8,700,112	04/15/2014	Kiani	
	221	8,690,799	04/08/2014	Telfort et al.	
	222	2014/0114199	04/24/2014	Lamego et al.	
	223	2014/0100434	04/10/2014	Diab et al.	
	224	2014/0094667	04/03/2014	Schurman et al.	
	225	RE44,875	04/29/2014	Kiani et al.	
	226	RE44,823	04/01/2014	Parker	
	227	8,682,407	03/25/2014	Al-Ali	
	228	2014/0081175	03/20/2014	Telfort	
	229	8,676,286	03/18/2014	Weber et al.	
	230	8,670,814	03/11/2014	Diab et al.	
	231	2014/0081100	03/20/2014	Muhsin et al.	
	232	8,670,811	03/11/2014	O'Reilly	

Examiner Signature	<u>/MARJAN FARDANESH/</u>	Date Considered	09/18/2018
<p>*Examiner: Initial if reference considered, whether or not citation is in conformance with MPEP 609. Draw line through citation if not in conformance and not considered. Include copy of this form with next communication to applicant.</p>			

T¹ - Place a check mark in this area when an English language Translation is attached.

ALL REFERENCES CONSIDERED EXCEPT WHERE LINED THROUGH. /M.F/

APL_MAS_ITC_00557122

Receipt date: 06/28/2016

15/195,199 - GAU: 3735

PTO/SB/08 Equivalent

INFORMATION DISCLOSURE STATEMENT BY APPLICANT	Application No.	Unknown	
	Filing Date	Herewith	
	First Named Inventor	Ammar Al-Ali	
	Art Unit	Unknown	
<i>(Multiple sheets used when necessary)</i>		Examiner	Unknown
SHEET 9 OF 24		Attorney Docket No.	MASIMO.1007A

U.S. PATENT DOCUMENTS

Examiner Initials	Cite No.	Document Number Number - Kind Code (if known) Example: 1,234,567 B1	Publication Date MM-DD-YYYY	Name of Patentee or Applicant	Pages, Columns, Lines Where Relevant Passages or Relevant Figures Appear
	233	8,667,967	03/11/2014	Al- Ali et al.	
	234	2014/0077956	03/20/2014	Sampath et al.	
	235	8,666,468	03/04/2014	Al-Ali	
	236	2014/0066783	03/06/2014	Kiani et al.	
	237	8,663,107	03/04/2014	Kiani	
	238	2014/0051953	02/20/2014	Lamego et al.	
	239	8,652,060	02/18/2014	Al-Ali	
	240	2014/0034353	02/06/2014	Al-Ali et al.	
	241	8,641,631	02/04/2014	Sierra et al.	
	242	8,634,889	01/21/2014	Al-Ali et al.	
	243	8,630,691	01/14/2014	Lamego et al.	
	244	2014/0012100	01/09/2014	Al-Ali et al.	
	245	8,626,255	01/07/2014	Al-Ali et al.	
	246	2013/0331660	12/12/2013	Al-Ali et al.	
	247	2013/0331670	12/12/2013	Kiani	
	248	8,606,342	12/10/2013	Diab	
	249	2013/0324808	12/05/2013	Al-Ali et al.	
	250	8,600,467	12/03/2013	Al-Ali et al.	
	251	8,588,880	11/19/2013	Abdul-Hafiz et al.	
	252	8,584,345	11/19/2013	Al-Ali et al.	
	253	8,581,732	11/12/2013	Al-Ali et al.	
	254	2013/0317370	11/28/2013	Dalvi et al.	
	255	2013/0296713	11/07/2013	Al-Ali et al.	
	256	2013/0296672	11/07/2013	O'Neil et al.	
	257	8,577,431	11/05/2013	Lamego et al.	
	258	8,571,619	10/29/2013	Al-Ali et al.	
	259	8,571,618	10/29/2013	Lamego et al.	
	260	8,571,617	10/29/2013	Reichgott et al.	
	261	8,570,503	10/29/2013	Vo et al.	

Examiner Signature <u>/MARJAN FARDANESH/</u>	Date Considered 09/18/2018
*Examiner: Initial if reference considered, whether or not citation is in conformance with MPEP 609. Draw line through citation if not in conformance and not considered. Include copy of this form with next communication to applicant.	

T¹ - Place a check mark in this area when an English language Translation is attached.

ALL REFERENCES CONSIDERED EXCEPT WHERE LINED THROUGH. /M.F/

APL_MAS_ITC_00557123

Receipt date: 06/28/2016

15/195,199 - GAU: 3735

PTO/SB/08 Equivalent

INFORMATION DISCLOSURE STATEMENT BY APPLICANT	Application No.	Unknown	
	Filing Date	Herewith	
	First Named Inventor	Ammar Al-Ali	
	Art Unit	Unknown	
<i>(Multiple sheets used when necessary)</i>		Examiner	Unknown
SHEET 10 OF 24		Attorney Docket No.	MASIMO.1007A

U.S. PATENT DOCUMENTS

Examiner Initials	Cite No.	Document Number <i>Number - Kind Code (if known)</i> Example: 1,234,567 B1	Publication Date MM-DD-YYYY	Name of Patentee or Applicant	Pages, Columns, Lines Where Relevant Passages or Relevant Figures Appear
	262	8,570,167	10/29/2013	Al-Ali	
	263	D692,145	10/22/2013	Al-Ali et al.	
	264	2013/0274572	10/17/2013	Al-Ali et al.	
	265	8,560,034	10/15/2013	Diab et al.	
	266	8,560,032	10/15/2013	Al-Ali et al.	
	267	2013/0267804	10/10/2013	Al-Ali	
	268	2013/0262730	10/03/2013	Al-Ali et al.	
	269	8,548,550	10/01/2013	Al-Ali et al.	
	270	8,548,549	10/01/2013	Schurman et al.	
	271	8,548,548	10/01/2013	Al-Ali	
	272	8,547,209	10/01/2013	Kiani et al.	
	273	8,532,728	09/10/2013	Diab et al.	
	274	2013/0253334	09/26/2013	Al-Ali et al.	
	275	8,532,727	09/10/2013	Ali et al.	
	276	8,529,301	09/10/2013	Al-Ali et al.	
	277	2013/0243021	09/19/2013	Siskavich	
	278	8,523,781	09/03/2013	Al-Ali	
	279	8,515,509	08/20/2013	Bruinsma et al.	
	280	2013/0211214	08/15/2013	Olsen	
	281	8,509,867	08/13/2013	Workman et al.	
	282	8,504,128	08/06/2013	Blank et al.	
	283	8,498,684	0730//2013	Weber et al.	
	284	8,489,364	07/16/2013	Weber et al.	
	285	2013/0190581	07/25/2013	Al-Ali et al.	
	286	8,483,787	07/09/2013	Al-Ali et al.	
	287	8,473,020	06/25/2013	Kiani et al.	
	288	8,471,713	06/25/2013	Poeze et al.	
	289	8,466,286	06/18/2013	Bellot et al.	
	290	8,463,349	06/11/2013	Diab et al.	

Examiner Signature	<u>/MARJAN FARDANESH/</u>	Date Considered	09/18/2018
<p>*Examiner: Initial if reference considered, whether or not citation is in conformance with MPEP 609. Draw line through citation if not in conformance and not considered. Include copy of this form with next communication to applicant.</p>			

T¹ - Place a check mark in this area when an English language Translation is attached.

ALL REFERENCES CONSIDERED EXCEPT WHERE LINED THROUGH. /M.F/

APL_MAS_ITC_00557124

Receipt date: 06/28/2016

15/195,199 - GAU: 3735

PTO/SB/08 Equivalent

INFORMATION DISCLOSURE STATEMENT BY APPLICANT	Application No.	Unknown	
	Filing Date	Herewith	
	First Named Inventor	Ammar Al-Ali	
	Art Unit	Unknown	
<i>(Multiple sheets used when necessary)</i>		Examiner	Unknown
SHEET 11 OF 24		Attorney Docket No.	MASIMO.1007A

U.S. PATENT DOCUMENTS

Examiner Initials	Cite No.	Document Number <i>Number - Kind Code (if known)</i> Example: 1,234,567 B1	Publication Date MM-DD-YYYY	Name of Patentee or Applicant	Pages, Columns, Lines Where Relevant Passages or Relevant Figures Appear
	291	8,457,707	06/04/2013	Kiani	
	292	8,457,703	06/04/2013	Al-Ali	
	293	8,455,290	06/04/2013	Siskavich	
	294	8,437,825	05/07/2013	Dalvi et al.	
	295	8,430,817	04/30/2013	Al-Ali et al.	
	296	8,428,967	04/23/2013	Olsen et al.	
	297	8,423,106	04/16/2013	Lamego et al.	
	298	2013/0096936	04/18/2013	Sampath et al.	
	299	8,418,524	04/16/2013	Al-Ali	
	300	2013/0096405	04/18/2013	Garfio	
	301	8,414,499	04/09/2013	Al-Ali et al.	
	302	8,405,608	03/26/2013	Al-Ali et al.	
	303	8,401,602	03/19/2013	Kiani	
	304	2013/0060147	03/07/2013	Welch et al.	
	305	8,399,822	03/19/2013	Al-Ali	
	306	8,388,353	03/05/2013	Kiani et la.	
	307	2013/0041591	02/14/2013	Lamego	
	308	8,385,996	02/26/2013	Smith et al.	
	309	2013/0046204	02/21/2013	Lamego et al.	
	310	8,385,995	02/26/2013	Al-ali et al.	
	311	8,374,665	02/12/2013	Lamego	
	312	8,364,226	01/29/2013	Diab et al.	
	313	8,364,223	01/29/2013	Al-Ali et al.	
	314	2013/0023775	01/24/2013	Lamego et al.	
	315	8,359,080	01/22/2013	Diab et al.	
	316	8,385,996	02/26/2013	Smith et al.	
	317	8,374,665	02/12/2013	Lamego	
	318	8,355,766	01/15/2013	MacNeish, III et al.	
	319	8,353,842	01/15/2013	Al-Ali et al.	

Examiner Signature	<u>/MARJAN FARDANESH/</u>	Date Considered	<u>09/18/2018</u>
<p>*Examiner: Initial if reference considered, whether or not citation is in conformance with MPEP 609. Draw line through citation if not in conformance and not considered. Include copy of this form with next communication to applicant.</p>			

T¹ - Place a check mark in this area when an English language Translation is attached.

ALL REFERENCES CONSIDERED EXCEPT WHERE LINED THROUGH. /M.F/

APL_MAS_ITC_00557125

Receipt date: 06/28/2016

15/195,199 - GAU: 3735

PTO/SB/08 Equivalent

INFORMATION DISCLOSURE STATEMENT BY APPLICANT	Application No.	Unknown	
	Filing Date	Herewith	
	First Named Inventor	Ammar Al-Ali	
	Art Unit	Unknown	
<i>(Multiple sheets used when necessary)</i>		Examiner	Unknown
SHEET 12 OF 24		Attorney Docket No.	MASIMO.1007A

U.S. PATENT DOCUMENTS

Examiner Initials	Cite No.	Document Number <i>Number - Kind Code (if known)</i> Example: 1,234,567 B1	Publication Date MM-DD-YYYY	Name of Patentee or Applicant	Pages, Columns, Lines Where Relevant Passages or Relevant Figures Appear
	320	2013/0006076	01/03/2013	McHale	
	321	8,346,330	01/01/2013	Lamego	
	322	2012/0330112	12/27/2012	Lamego et al.	
	323	8,337,403	12/25/2012	Al-Ali et al.	
	324	2012/0319816	12/20/2012	Al-Ali	
	325	RE43,860	12/11/2012	Parker	
	326	8,315,683	11/20/2012	Al-Ali et al.	
	327	8,310,336	11/13/2012	Muhsin et al.	
	328	2012/0296178	11/22/2012	Lamego et al.	
	329	2012/0283524	11/08/2012	Kiani et al.	
	330	8,306,596	11/06/2012	Schurman et al.	
	331	8,301,217	10/30/2012	Al-Ali et al.	
	332	8,274,360	09/25/2012	Sampath et al.	
	333	8,265,723	09/11/2012	McHale et al.	
	334	8,260,577	09/04/2012	Weber et al.	
	335	8,255,028	08/28/2012	Al-Ali et al.	
	336	8,255,027	08/28/2012	Al-Ali et al.	
	337	2012/0209084	08/16/2012	Olsen et al.	
	338	8,255,026	08/28/2012	Al-Ali	
	339	2012/0209082	08/16/2012	Al-Ali	
	340	8,244,325	08/14/2012	Al-Ali et al.	
	341	8,233,955	07/31/2012	Al-Ali et al.	
	342	8,229,533	07/24/2012	Diab et al.	
	343	8,228,181	07/24/2012	Al-Ali	
	344	8,224,411	07/17/2012	Al-Ali et al.	
	345	2012/0179006	07/12/2012	Jansen et al.	
	346	8,219,172	07/10/2012	Schurman et al.	
	347	2012/0165629	06/28/2012	Merritt et al.	
	348	8,204,566	06/19/2012	Schurman et al.	

Examiner Signature <u>/MARJAN FARDANESH/</u>	Date Considered <u>09/18/2018</u>
<p>*Examiner: Initial if reference considered, whether or not citation is in conformance with MPEP 609. Draw line through citation if not in conformance and not considered. Include copy of this form with next communication to applicant.</p>	

T¹ - Place a check mark in this area when an English language Translation is attached.

ALL REFERENCES CONSIDERED EXCEPT WHERE LINED THROUGH. /M.F/

APL_MAS_ITC_00557126

Receipt date: 06/28/2016

15/195,199 - GAU: 3735

PTO/SB/08 Equivalent

INFORMATION DISCLOSURE STATEMENT BY APPLICANT	Application No.	Unknown	
	Filing Date	Herewith	
	First Named Inventor	Ammar Al-Ali	
	Art Unit	Unknown	
<i>(Multiple sheets used when necessary)</i>		Examiner	Unknown
SHEET 13 OF 24		Attorney Docket No.	MASIMO.1007A

U.S. PATENT DOCUMENTS

Examiner Initials	Cite No.	Document Number Number - Kind Code (if known) Example: 1,234,567 B1	Publication Date MM-DD-YYYY	Name of Patentee or Applicant	Pages, Columns, Lines Where Relevant Passages or Relevant Figures Appear
	349	8,203,704	06/19/2012	Merritt et al.	
	350	8,203,438	06/19/2012	Kiani et al.	
	351	8,190,227	05/29/2012	Diab et al.	
	352	8,190,223	05/29/2012	Al-Ali et al.	
	353	8,185,180	05/22/2012	Diab et al.	
	354	8,182,443	05/22/2012	Kiani	
	355	8,180,420	05/15/2012	Diab et al.	
	356	8,175,672	05/08/2012	Parker	
	357	2012/0088984	04/12/2012	Al-Ali et al.	
	358	8,150,487	04/03/2012	Diab et al.	
	359	2012/0059267	03/08/2012	Lamego et al.	
	360	8,145,287	03/27/2012	Diab et al.	
	361	8,130,105	03/06/2012	Al-Ali et al.	
	362	8,128,572	03/06/2012	Diab et al.	
	363	8,126,528	02/28/2012	Diab et al.	
	364	2012/0046557	02/23/2012	Kiani	
	365	8,118,620	02/21/2012	Al-Ali et al.	
	366	2012/0041316	02/16/2012	Al-Ali et al.	
	367	RE43,169	02/07/2012	Parker	
	368	2011/0301444	12/08/2011	Al-Ali	
	369	2011/0288383	11/24/2011	Diab	
	370	8,050,728	11/01/2011	Al-Ali et al.	
	371	8,048,040	11/01/2011	Kiani	
	372	8,046,042	10/25/2011	Diab et al.	
	373	8,046,041	10/25/2011	Diab et al.	
	374	8,046,040	10/25/2011	Ali et al.	
	375	8,036,728	10/11/2011	Diab et al.	
	376	8,036,727	10/11/2011	Schurman et al.	
	377	8,029,765	10/04/2011	Bellott et al.	

Examiner Signature	<u>/MARJAN FARDANESH/</u>	Date Considered	09/18/2018
<p>*Examiner: Initial if reference considered, whether or not citation is in conformance with MPEP 609. Draw line through citation if not in conformance and not considered. Include copy of this form with next communication to applicant.</p>			

T¹ - Place a check mark in this area when an English language Translation is attached.

ALL REFERENCES CONSIDERED EXCEPT WHERE LINED THROUGH. /M.F/

APL_MAS_ITC_00557127

Receipt date: 06/28/2016

15/195,199 - GAU: 3735

PTO/SB/08 Equivalent

INFORMATION DISCLOSURE STATEMENT BY APPLICANT	Application No.	Unknown	
	Filing Date	Herewith	
	First Named Inventor	Ammar Al-Ali	
	Art Unit	Unknown	
<i>(Multiple sheets used when necessary)</i>		Examiner	Unknown
SHEET 14 OF 24		Attorney Docket No.	MASIMO.1007A

U.S. PATENT DOCUMENTS

Examiner Initials	Cite No.	Document Number <i>Number - Kind Code (if known)</i> Example: 1,234,567 B1	Publication Date MM-DD-YYYY	Name of Patentee or Applicant	Pages, Columns, Lines Where Relevant Passages or Relevant Figures Appear
	378	8,028,701	10/04/2011	Al-Ali et al.	
	379	2011/0237969	09/29/2011	Eckerbom et al.	
	380	2011/0230733	09/22/2011	Al-Ali	
	381	2011/0213212	09/01/2011	Al-Ali	
	382	RE42,753	09/27/2011	Kiani-Azarbayjany et al.	
	383	8,019,400	09/13/2011	Diab et al.	
	384	2011/0208015	08/25/2011	Welch et al.	
	385	8,008,088	08/30/2011	Bellott et al.	
	386	8,000,761	08/16/2011	Al-Ali	
	387	7,991,446	08/02/2011	Al-Ali et al.	
	388	7,990,382	08/02/2011	Kiani	
	389	7,988,637	08/02/2011	Diab	
	390	7,976,472	07/12/2011	Kiani	
	391	7,962,190	06/14/2011	Diab et al.	
	392	7,962,188	06/14/2011	Kiani et al.	
	393	7,957,780	06/07/2011	Lamego et al.	
	394	7,951,086	05/31/2011	Flaherty et al.	
	395	2011/0125060	05/26/2011	Telfort et al.	
	396	7,941,199	05/10/2011	Kiani	
	397	7,937,130	05/03/2011	Diab et al.	
	398	2011/0105854	05/05/2011	Kiani et al.	
	399	7,937,129	05/03/2011	Mason et al.	
	400	7,937,128	05/03/2011	Al-Ali	
	401	2011/0082711	04/07/2011	Poeze et al.	
	402	7,919,713	04/05/2011	Al-Ali et al.	
	403	7,910,875	03/22/2011	Al-Ali	
	404	7,909,772	03/22/2011	Popov et al.	
	405	7,904,132	03/08/2011	Weber et al.	
	406	7,899,518	03/01/2011	Trepagnier et al.	

Examiner Signature	<u>/MARJAN FARDANESH/</u>	Date Considered	09/18/2018
<p>*Examiner: Initial if reference considered, whether or not citation is in conformance with MPEP 609. Draw line through citation if not in conformance and not considered. Include copy of this form with next communication to applicant.</p>			

T¹ - Place a check mark in this area when an English language Translation is attached.

ALL REFERENCES CONSIDERED EXCEPT WHERE LINED THROUGH. /M.F/

APL_MAS_ITC_00557128

Receipt date: 06/28/2016

15/195,199 - GAU: 3735

PTO/SB/08 Equivalent

INFORMATION DISCLOSURE STATEMENT BY APPLICANT	Application No.	Unknown	
	Filing Date	Herewith	
	First Named Inventor	Ammar Al-Ali	
	Art Unit	Unknown	
<i>(Multiple sheets used when necessary)</i>		Examiner	Unknown
SHEET 15 OF 24		Attorney Docket No.	MASIMO.1007A

U.S. PATENT DOCUMENTS

Examiner Initials	Cite No.	Document Number <i>Number - Kind Code (if known)</i> Example: 1,234,567 B1	Publication Date MM-DD-YYYY	Name of Patentee or Applicant	Pages, Columns, Lines Where Relevant Passages or Relevant Figures Appear
	407	7,899,507	03/01/2011	Al-Ali et al.	
	408	7,894,868	02/22/2011	Al-Ali et al.	
	409	7,891,355	02/22/2011	Al-Ali et al.	
	410	7,880,626	02/01/2011	Al-Ali et al.	
	411	7,880,606	02/01/2011	Al-Ali	
	412	7,873,497	01/18/2011	Weber et al.	
	413	7,865,222	01/04/2011	Weber et al.	
	414	7,844,315	11/30/2010	Al-Ali	
	415	7,844,314	11/30/2010	Al-Ali	
	416	7,844,313	11/30/2010	Kiani et al.	
	417	RE41,912	11/02/2010	Parker	
	418	7,822,452	10/26/2010	Schurman et al.	
	419	7,801,581	09/21/2010	Diab	
	420	7,791,155	09/07/2010	Diab	
	421	D621,516	08/10/2010	Kiani et al.	
	422	7,764,982	07/27/2010	Dalke et al.	
	423	7,761,128	07/20/2010	Al-Ali et al.	
	424	7,761,127	07/20/2010	Al-Ali et al.	
	425	7,734,320	06/08/2010	Al-Ali	
	426	7,729,733	06/01/2010	Al-Ali et al.	
	427	RE41,317	05/04/2010	Parker	
	428	D614,305	04/20/2010	Al-Ali et al.	
	429	2010/0030040	02/04/2010	Poeze et al.	
	430	D609,193	02/02/2010	Al-Ali et al.	
	431	2010/0004518	01/07/2010	Vo et al.	
	432	7,647,083	01/12/2010	Al-Ali et al.	
	433	D606,659	12/22/2009	Kiani et al.	
	434	2009/0275844	11/05/2009	Al-Ali	
	435	7,618,375	11/17/2009	Flaherty	

Examiner Signature	/MARJAN FARDANESH/	Date Considered	09/18/2018
<p>*Examiner: Initial if reference considered, whether or not citation is in conformance with MPEP 609. Draw line through citation if not in conformance and not considered. Include copy of this form with next communication to applicant.</p>			

T¹ - Place a check mark in this area when an English language Translation is attached.

ALL REFERENCES CONSIDERED EXCEPT WHERE LINED THROUGH. /M.F/

APL_MAS_ITC_00557129

Receipt date: 06/28/2016

15/195,199 - GAU: 3735

PTO/SB/08 Equivalent

INFORMATION DISCLOSURE STATEMENT BY APPLICANT	Application No.	Unknown	
	Filing Date	Herewith	
	First Named Inventor	Ammar Al-Ali	
	Art Unit	Unknown	
<i>(Multiple sheets used when necessary)</i>		Examiner	Unknown
SHEET 16 OF 24		Attorney Docket No.	MASIMO.1007A

U.S. PATENT DOCUMENTS

Examiner Initials	Cite No.	Document Number <i>Number - Kind Code (if known)</i> Example: 1,234,567 B1	Publication Date MM-DD-YYYY	Name of Patentee or Applicant	Pages, Columns, Lines Where Relevant Passages or Relevant Figures Appear
	436	2009/0275813	11/05/2009	Davis	
	437	2009/0247984	10/01/2009	Lamego et al.	
	438	7,596,398	09/29/2009	Al-Ali et al.	
	439	7,563,110	07/21/2009	Al-Ali et al.	
	440	7,530,955	05/12/2009	Diab et al.	
	441	7,530,949	05/12/2009	Al Ali et al.	
	442	7,530,942	05/12/2009	Diab	
	443	7,526,328	04/28/2009	Diab et al.	
	444	7,510,849	03/31/2009	Schurman et al.	
	445	7,509,494	03/24/2009	Al-Ali	
	446	7,509,154	03/24/2009	Diab et al.	
	447	7,500,950	03/10/2009	Al-Ali et al.	
	448	D587,657	03/03/2009	Al-Ali et al.	
	449	7,499,835	03/03/2009	Weber et al.	
	450	7,499,741	03/03/2009	Diab et al.	
	451	7,496,393	02/24/2009	Diab et al.	
	452	7,496,391	02/24/2009	Diab et al.	
	453	7,489,958	02/10/2009	Diab et al.	
	454	7,483,730	01/27/2009	Diab et al.	
	455	7,483,729	01/27/2009	Al-Ali et al.	
	456	7,471,971	12/30/2008	Diab et al.	
	457	7,471,969	12/30/2008	Diab et al.	
	458	7,469,157	12/23/2008	Diab et al.	
	459	7,467,002	12/16/2008	Weber et al.	
	460	7,454,240	11/18/2008	Diab et al.	
	461	7,440,787	10/21/2008	Diab	
	462	7,438,683	10/21/2008	Al-Ali et al.	
	463	7,428,432	09/23/2008	Ali et al.	
	464	7,415,297	08/19/2008	Al-Ali et al.	

Examiner Signature	<u>/MARJAN FARDANESH/</u>	Date Considered	09/18/2018
<p>*Examiner: Initial if reference considered, whether or not citation is in conformance with MPEP 609. Draw line through citation if not in conformance and not considered. Include copy of this form with next communication to applicant.</p>			

T¹ - Place a check mark in this area when an English language Translation is attached.

ALL REFERENCES CONSIDERED EXCEPT WHERE LINED THROUGH. /M.F/

APL_MAS_ITC_00557130

Receipt date: 06/28/2016

15/195,199 - GAU: 3735

PTO/SB/08 Equivalent

INFORMATION DISCLOSURE STATEMENT BY APPLICANT	Application No.	Unknown	
	Filing Date	Herewith	
	First Named Inventor	Ammar Al-Ali	
	Art Unit	Unknown	
<i>(Multiple sheets used when necessary)</i>		Examiner	Unknown
SHEET 17 OF 24		Attorney Docket No.	MASIMO.1007A

U.S. PATENT DOCUMENTS

Examiner Initials	Cite No.	Document Number <i>Number - Kind Code (if known)</i> Example: 1,234,567 B1	Publication Date MM-DD-YYYY	Name of Patentee or Applicant	Pages, Columns, Lines Where Relevant Passages or Relevant Figures Appear
	465	7,383,070	06/03/2008	Diab et al.	
	466	7,377,899	05/27/2008	Weber et al.	
	467	7,377,794	05/27/2008	Al Ali et al.	
	468	7,376,453	05/20/2008	Diab et al.	
	469	7,373,194	05/13/2008	Weber et al.	
	470	7,373,193	05/13/2008	Al-Ali et al.	
	471	7,371,981	05/13/2008	Abdul-Hafiz	
	472	7,356,365	04/08/2008	Schurman	
	473	D566,282	04/08/2008	Al-Ali et al.	
	474	7,355,512	04/08/2008	Al-Ali	
	475	7,343,186	03/11/2008	Lamego et al.	
	476	7,341,559	03/11/2008	Schulz et al.	
	477	7,340,287	03/04/2008	Mason et al.	
	478	7,332,784	02/19/2008	Mills, et al.	
	479	2008/0030468	02/07/2008	Al-Ali et al.	
	480	7,328,053	02/05/2008	Diab et al.	
	481	2007/0282478	12/06/2007	Al-Ali et al.	
	482	7,295,866	11/13/2007	Al-Ali	
	483	7,292,883	11/06/2007	De Felice et al.	
	484	D554,263	10/30/2007	Al-Ali	
	485	7,289,835	10/30/2007	Mansfield et al.	
	486	7,280,858	10/09/2007	Al-Ali et al.	
	487	7,274,955	09/25/2007	Kiani et al.	
	488	7,272,425	09/18/2007	Al-Ali	
	489	7,254,434	08/07/2007	Schulz et al.	
	490	7,254,433	08/07/2007	Diab et al.	
	491	7,254,431	08/07/2007	Al-Ali	
	492	7,254,429	08/07/2007	Schurman et al.	
	493	7,245,953	07/17/2007	Parker	

Examiner Signature /MARJAN FARDANESH/	Date Considered 09/18/2018
<p>*Examiner: Initial if reference considered, whether or not citation is in conformance with MPEP 609. Draw line through citation if not in conformance and not considered. Include copy of this form with next communication to applicant.</p>	

T¹ - Place a check mark in this area when an English language Translation is attached.

ALL REFERENCES CONSIDERED EXCEPT WHERE LINED THROUGH. /M.F/

APL_MAS_ITC_00557131

Receipt date: 06/28/2016

15/195,199 - GAU: 3735

PTO/SB/08 Equivalent

INFORMATION DISCLOSURE STATEMENT BY APPLICANT	Application No.	Unknown	
	Filing Date	Herewith	
	First Named Inventor	Ammar Al-Ali	
	Art Unit	Unknown	
<i>(Multiple sheets used when necessary)</i>		Examiner	Unknown
SHEET 18 OF 24		Attorney Docket No.	MASIMO.1007A

U.S. PATENT DOCUMENTS

Examiner Initials	Cite No.	Document Number <i>Number - Kind Code (if known)</i> Example: 1,234,567 B1	Publication Date MM-DD-YYYY	Name of Patentee or Applicant	Pages, Columns, Lines Where Relevant Passages or Relevant Figures Appear
	494	7,239,905	07/03/2007	Kiani-Azarbayjany et al.	
	495	RE39,672	06/05/2007	Shehada et al.	
	496	7,225,007	05/29/2007	Al-Ali	
	497	7,225,006	05/29/2007	Al-Ali et al.	
	498	7,221,971	05/22/2007	Diab	
	499	7,215,986	05/08/2007	Diab	
	500	7,215,984	05/08/2007	Diab	
	501	7,190,261	03/13/2007	Al-Ali	
	502	7,186,966	03/06/2007	Al-Ali	
	503	7,149,561	12/12/2006	Diab	
	504	7,142,901	11/28/2006	Kiani et al.	
	505	7,132,641	11/07/2006	Schulz et al.	
	506	7,096,054	08/22/2006	Abdul-Hafiz et al.	
	507	7,096,052	08/22/2006	Mason et al.	
	508	7,067,893	06/27/2006	Mills et al.	
	509	7,044,918	05/16/2006	Diab	
	510	7,041,060	05/09/2006	Flaherty et al	
	511	7,039,449	05/02/2006	Al-Ali	
	512	7,030,749	04/18/2006	Al-Ali	
	513	7,027,849	04/11/2006	Al-Ali	
	514	7,024,233	04/04/2006	Ali et al.	
	515	7,015,451	03/21/2006	Dalke et al.	
	516	7,003,339	02/21/2006	Diab et al.	
	517	7,003,338	02/21/2006	Weber et al.	
	518	6,999,904	02/14/2006	Weber et al.	
	519	6,996,427	02/07/2006	Ali et al.	
	520	6,993,371	01/31/2006	Kiani et al.	
	521	6,985,764	01/10/2006	Mason et al.	
	522	6,979,812	12/27/2005	Al-Ali	

Examiner Signature	<u>/MARJAN FARDANESH/</u>	Date Considered	<u>09/18/2018</u>
<p>*Examiner: Initial if reference considered, whether or not citation is in conformance with MPEP 609. Draw line through citation if not in conformance and not considered. Include copy of this form with next communication to applicant.</p>			

T¹ - Place a check mark in this area when an English language Translation is attached.

ALL REFERENCES CONSIDERED EXCEPT WHERE LINED THROUGH. /M.F/

APL_MAS_ITC_00557132

Receipt date: 06/28/2016

15/195,199 - GAU: 3735

PTO/SB/08 Equivalent

INFORMATION DISCLOSURE STATEMENT BY APPLICANT	Application No.	Unknown	
	Filing Date	Herewith	
	First Named Inventor	Ammar Al-Ali	
	Art Unit	Unknown	
<i>(Multiple sheets used when necessary)</i>		Examiner	Unknown
SHEET 19 OF 24		Attorney Docket No.	MASIMO.1007A

U.S. PATENT DOCUMENTS

Examiner Initials	Cite No.	Document Number <i>Number - Kind Code (if known)</i> Example: 1,234,567 B1	Publication Date MM-DD-YYYY	Name of Patentee or Applicant	Pages, Columns, Lines Where Relevant Passages or Relevant Figures Appear
	523	2005/0277819	12/15/2005	Kiani et al.	
	524	6,970,792	11/29/2005	Diab	
	525	6,961,598	11/01/2005	Diab	
	526	6,950,687	09/27/2005	Al-Ali	
	527	6,943,348	09/13/2005	Coffin IV	
	528	6,939,305	09/06/2005	Flaherty et al.	
	529	6,934,570	08/23/2005	Kiani et al.	
	530	6,931,268	08/16/2005	Kiani-Azarbayjany et al.	
	531	6,920,345	07/19/2005	Al-Ali et al.	
	532	6,898,452	05/24/2005	Al-Ali et al.	
	533	6,861,639	03/01/2005	Al-Ali	
	534	6,852,083	02/08/2005	Caro et al.	
	535	6,850,788	02/01/2005	Al-Ali	
	536	6,850,787	02/01/2005	Weber et al.	
	537	6,830,711	12/14/2004	Mills et al.	
	538	6,826,419	11/30/2004	Diab et al.	
	539	6,822,564	11/23/2004	Al-Ali	
	540	6,816,741	11/09/2004	Diab	
	541	6,813,511	11/02/2004	Diab et al.	
	542	6,792,300	09/14/2004	Diab et al.	
	543	6,771,994	08/03/2004	Kiani et al.	
	544	6,770,028	08/03/2004	Ali et al.	
	545	6,760,607	07/06/2004	Al-Ali	
	546	6,745,060	06/01/2004	Diab et al.	
	547	6,735,459	05/11/2004	Parker	
	548	6,728,560	04/27/2004	Kollias, et al.	
	549	6,725,075	04/20/2004	Al-Ali	
	550	6,721,585	04/13/2004	Parker	
	551	6,721,582	04/13/2004	Trepagnier, et al.	

Examiner Signature /MARJAN FARDANESH/	Date Considered 09/18/2018
<p>*Examiner: Initial if reference considered, whether or not citation is in conformance with MPEP 609. Draw line through citation if not in conformance and not considered. Include copy of this form with next communication to applicant.</p>	

T¹ - Place a check mark in this area when an English language Translation is attached.

ALL REFERENCES CONSIDERED EXCEPT WHERE LINED THROUGH. /M.F/

APL_MAS_ITC_00557133

Receipt date: 06/28/2016

15/195,199 - GAU: 3735

PTO/SB/08 Equivalent

INFORMATION DISCLOSURE STATEMENT BY APPLICANT	Application No.	Unknown	
	Filing Date	Herewith	
	First Named Inventor	Ammar Al-Ali	
	Art Unit	Unknown	
<i>(Multiple sheets used when necessary)</i>		Examiner	Unknown
SHEET 20 OF 24		Attorney Docket No.	MASIMO.1007A

U.S. PATENT DOCUMENTS

Examiner Initials	Cite No.	Document Number <i>Number - Kind Code (if known)</i> Example: 1,234,567 B1	Publication Date MM-DD-YYYY	Name of Patentee or Applicant	Pages, Columns, Lines Where Relevant Passages or Relevant Figures Appear
	552	RE38,492	04/06/2004	Diab et al.	
	553	6,714,804	03/30/2004	Al-Ali et al.	
	554	RE38,476	03/30/2004	Diab et al.	
	555	6,699,194	03/02/2004	Diab et al.	
	556	6,697,658	02/24/2004	Al-Ali	
	557	6,697,657	02/24/2004	Shehada, et al.	
	558	6,697,656	02/24/2004	Al-Ali	
	559	6,684,091	01/27/2004	Parker	
	560	6,684,090	01/27/2004	Ali et al.	
	561	6,678,543	01/13/2004	Diab et al.	
	562	6,671,531	12/30/2003	Al-Ali et al.	
	563	6,661,161	12/09/2003	Lanzo et al.	
	564	6,658,276	12/02/2003	Kiani et al.	
	565	6,654,624	11/25/2003	Diab et al.	
	566	6,650,917	11/18/2003	Diab et al.	
	567	6,643,530	11/04/2003	Diab et al.	
	568	6,640,116	10/28/2003	Diab	
	569	6,639,668	10/28/2003	Trepagnier, Pierre	
	570	6,632,181	10/14/2003	Flaherty et al.	
	571	6,606,511	08/12/2003	Ali et al.	
	572	6,597,933	07/22/2003	Kiani et al.	
	573	6,597,932	07/22/2003	Tian et al.	
	574	6,595,316	07/22/2003	Cybulski et al.	
	575	6,584,336	06/24/2003	Ali et al.	
	576	6,580,086	06/17/2003	Schulz et al.	
	577	6,542,764	04/01/2003	Al-Ali et al.	
	578	6,541,756	04/01/2003	Schulz et al.	
	579	6,526,300	02/25/2003	Kiani et al.	
	580	6,525,386	02/25/2003	Mills et al.	

Examiner Signature / MARJAN FARDANESH /	Date Considered 09/18/2018
<p>*Examiner: Initial if reference considered, whether or not citation is in conformance with MPEP 609. Draw line through citation if not in conformance and not considered. Include copy of this form with next communication to applicant.</p>	

T¹ - Place a check mark in this area when an English language Translation is attached.

ALL REFERENCES CONSIDERED EXCEPT WHERE LINED THROUGH. /M.F/

APL_MAS_ITC_00557134

Receipt date: 06/28/2016

15/195,199 - GAU: 3735

PTO/SB/08 Equivalent

INFORMATION DISCLOSURE STATEMENT BY APPLICANT	Application No.	Unknown	
	Filing Date	Herewith	
	First Named Inventor	Ammar Al-Ali	
	Art Unit	Unknown	
<i>(Multiple sheets used when necessary)</i>		Examiner	Unknown
SHEET 21 OF 24		Attorney Docket No.	MASIMO.1007A

U.S. PATENT DOCUMENTS

Examiner Initials	Cite No.	Document Number <i>Number - Kind Code (if known)</i> Example: 1,234,567 B1	Publication Date MM-DD-YYYY	Name of Patentee or Applicant	Pages, Columns, Lines Where Relevant Passages or Relevant Figures Appear
	581	6,519,487	02/11/2003	Parker	
	582	6,515,273	02/04/2003	Al-Ali	
	583	6,505,059	01/07/2003	Kollias, et al.	
	584	6,501,975	12/31/2002	Diab et al.	
	585	6,470,199	10/22/2002	Kopotic et al.	
	586	6,463,311	10/08/2002	Diab	
	587	6,430,525	08/06/2002	Weber et al.	
	588	6,430,437	08/06/2002	Marro	
	589	6,397,091	05/28/2002	Diab et al.	
	590	6,388,240	05/14/2002	Schulz et al.	
	591	6,377,829	04/23/2002	Al-Ali	
	592	6,371,921	04/16/2002	Caro et al.	
	593	6,368,283	04/09/2002	Xu, et al.	
	594	6,360,114	03/19/2002	Diab et al.	
	595	6,349,228	02/19/2002	Kiani et al.	
	596	6,343,224	01/29/2002	Parker	
	597	6,334,065	12/25/2001	Al-Ali et al.	
	598	6,325,761	12/04/2001	Jay	
	599	6,321,100	11/20/2001	Parker	
	600	6,317,627	11/13/2001	Ennen et al.	
	601	6,301,493	10/09/2001	Marro et al.	
	602	6,285,896	09/04/2001	Tobler et al.	
	603	6,280,213	08/28/2001	Tobler et al.	
	604	6,278,522	08/21/2001	Lepper, Jr. et al.	
	605	6,263,222	07/17/2001	Diab et al.	
	606	6,256,523	07/03/2001	Diab et al.	
	607	6,253,097	06/26/2001	Aronow et al.	
	608	6,241,683	06/05/2001	Macklem, et al.	
	609	6,236,872	05/22/2001	Diab et al.	

Examiner Signature /MARJAN FARDANESH/	Date Considered 09/18/2018
<p>*Examiner: Initial if reference considered, whether or not citation is in conformance with MPEP 609. Draw line through citation if not in conformance and not considered. Include copy of this form with next communication to applicant.</p>	

T¹ - Place a check mark in this area when an English language Translation is attached.

ALL REFERENCES CONSIDERED EXCEPT WHERE LINED THROUGH. /M.F/

APL_MAS_ITC_00557135

Receipt date: 06/28/2016

15/195,199 - GAU: 3735

PTO/SB/08 Equivalent

INFORMATION DISCLOSURE STATEMENT BY APPLICANT	Application No.	Unknown	
	Filing Date	Herewith	
	First Named Inventor	Ammar Al-Ali	
	Art Unit	Unknown	
<i>(Multiple sheets used when necessary)</i>		Examiner	Unknown
SHEET 22 OF 24		Attorney Docket No.	MASIMO.1007A

U.S. PATENT DOCUMENTS

Examiner Initials	Cite No.	Document Number <i>Number - Kind Code (if known)</i> Example: 1,234,567 B1	Publication Date MM-DD-YYYY	Name of Patentee or Applicant	Pages, Columns, Lines Where Relevant Passages or Relevant Figures Appear
	610	6,232,609	05/15/2001	Snyder, et al.	
	611	6,229,856	05/08/2001	Diab et al.	
	612	6,206,830	03/27/2001	Diab et al.	
	613	6,184,521	02/06/2001	Coffin, IV et al.	
	614	6,165,005	12/26/2000	Mills et al.	
	615	6,157,850	12/05/2000	Diab et al.	
	616	6,152,754	11/28/2000	Gerhardt et al.	
	617	6,151,516	11/21/2000	Kiani-Azarbayjany et al.	
	618	6,144,868	11/07/2000	Parker	
	619	6,129,675	10/10/2000	Jay	
	620	6,128,521	10/03/2000	Marro et al.	
	621	6,124,597	09/26/2000	Shehada	
	622	6,110,522	08/29/2000	Lepper, Jr. et al.	
	623	6,088,607	07/11/2000	Diab et al.	
	624	6,081,735	06/27/2000	Diab et al.	
	625	6,067,462	05/23/2000	Diab et al.	
	626	6,045,509	04/04/2000	Caro et al.	
	627	6,036,642	03/14/2000	Diab et al.	
	628	6,027,452	02/22/2000	Flaherty et al.	
	629	6,011,986	01/04/2000	Diab et al.	
	630	6,002,952	12/14/1999	Diab et al.	
	631	5,997,343	12/07/1999	Mills et al.	
	632	5,995,855	11/30/1999	Kiani et al.	
	633	5,940,182	08/17/1999	Lepper, Jr. et al.	
	634	5,934,925	08/10/1999	Tobler et al.	
	635	5,919,134	07/06/1999	Diab	
	636	5,904,654	05/18/1999	Wohlmann et al.	
	637	5,890,929	04/06/1999	Mills et al.	
	638	5,860,919	01/19/1999	Kiani-Azarbayjany et al.	

Examiner Signature /MARJAN FARDANESH/	Date Considered 09/18/2018
<p>*Examiner: Initial if reference considered, whether or not citation is in conformance with MPEP 609. Draw line through citation if not in conformance and not considered. Include copy of this form with next communication to applicant.</p>	

T¹ - Place a check mark in this area when an English language Translation is attached.

ALL REFERENCES CONSIDERED EXCEPT WHERE LINED THROUGH. /M.F/

APL_MAS_ITC_00557136

Receipt date: 06/28/2016

15/195,199 - GAU: 3735

PTO/SB/08 Equivalent

INFORMATION DISCLOSURE STATEMENT BY APPLICANT	Application No.	Unknown	
	Filing Date	Herewith	
	First Named Inventor	Ammar Al-Ali	
	Art Unit	Unknown	
<i>(Multiple sheets used when necessary)</i>		Examiner	Unknown
SHEET 23 OF 24		Attorney Docket No.	MASIMO.1007A

U.S. PATENT DOCUMENTS					
Examiner Initials	Cite No.	Document Number Number - Kind Code (if known) Example: 1,234,567 B1	Publication Date MM-DD-YYYY	Name of Patentee or Applicant	Pages, Columns, Lines Where Relevant Passages or Relevant Figures Appear
	639	5,833,618	11/10/1998	Caro et al.	
	640	5,830,131	11/03/1998	Caro et al.	
	641	5,823,950	10/20/1998	Diab et al.	
	642	5,810,734	09/22/1998	Caro et al.	
	643	5,791,347	08/11/1998	Flaherty et al.	
	644	5,785,659	07/28/1998	Caro et al.	
	645	5,782,757	07/21/1998	Diab et al.	
	646	5,769,785	06/23/1998	Diab et al.	
	647	5,760,910	06/02/1998	Lepper, Jr. et al.	
	648	5,758,644	06/02/1998	Diab et al.	
	649	5,743,262	04/28/1998	Lepper, Jr. et al.	
	650	D393,830	04/28/1998	Tobler et al.	
	651	5,685,299	11/11/1997	Diab et al.	
	652	5,645,440	07/08/1997	Tobler et al.	
	653	5,638,818	06/17/1997	Diab et al.	
	654	5,638,816	06/17/1997	Kiani-Azarbayjany et al.	
	655	5,632,272	05/27/1997	Diab et al.	
	656	5,602,924	02/11/1997	Durand et al.	
	657	5,590,649	01/07/1997	Caro et al.	
	658	5,562,002	10/08/1996	Lalin	
	659	5,561,275	10/01/1996	Savage, et al.	
	660	5,533,511	07/09/1996	Kaspari et al.	
	661	5,534,851	07/09/1996	Russek	
	662	5,494,043	02/27/1996	O'Sullivan et al.	
	663	5,490,505	02/13/1996	Diab et al.	
	664	5,482,036	01/09/1996	Diab et al.	
	665	5,479,934	01/02/1996	Imran	
	666	5,456,252	10/10/1995	Vari, et al.	
	667	D363,120	10/10/1995	Savage, et al.	

Examiner Signature	<u>/MARJAN FARDANESH/</u>	Date Considered	09/18/2018
<p>*Examiner: Initial if reference considered, whether or not citation is in conformance with MPEP 609. Draw line through citation if not in conformance and not considered. Include copy of this form with next communication to applicant.</p>			

T¹ - Place a check mark in this area when an English language Translation is attached.

ALL REFERENCES CONSIDERED EXCEPT WHERE LINED THROUGH. /M.F/

APL_MAS_ITC_00557137

Receipt date: 06/28/2016

15/195,199 - GAU: 3735

PTO/SB/08 Equivalent

INFORMATION DISCLOSURE STATEMENT BY APPLICANT	Application No.	Unknown	
	Filing Date	Herewith	
	First Named Inventor	Ammar Al-Ali	
	Art Unit	Unknown	
<i>(Multiple sheets used when necessary)</i>		Examiner	Unknown
SHEET 24 OF 24		Attorney Docket No.	MASIMO.1007A

U.S. PATENT DOCUMENTS					
Examiner Initials	Cite No.	Document Number <i>Number - Kind Code (if known)</i> Example: 1,234,567 B1	Publication Date MM-DD-YYYY	Name of Patentee or Applicant	Pages, Columns, Lines Where Relevant Passages or Relevant Figures Appear
	668	5,452,717	09/26/1995	Branigan et al.	
	669	D362,063	09/05/1995	Savage, et al.	
	670	D361,840	08/29/1995	Savage, et al.	
	671	5,431,170	07/11/1995	Mathews	
	672	D359,546	06/20/1995	Savage, et al.	
	673	5,377,676	01/03/1995	Vari, et al.	
	674	D353,196	12/06/1994	Savage, et al.	
	675	D353,195	12/06/1994	Savage, et al.	
	676	5,341,805	08/30/1994	Stavridi, et al.	
	677	5,337,744	08/16/1994	Branigan	
	678	5,319,355	06/07/1994	Russek	
	679	5,163,438	11/17/1992	Gordon et al.	
	680	5,069,213	12/03/1991	Polczynski	
	681	5,041,187	08/20/1991	Hink et al.	
	682	4,964,408	10/23/1990	Hink et al.	
	683	4,960,128	10/02/1990	Gordon et al.	

FOREIGN PATENT DOCUMENTS						
Examiner Initials	Cite No.	Foreign Patent Document <i>Country Code-Number-Kind Code</i> Example: JP 1234567 A1	Publication Date MM-DD-YYYY	Name of Patentee or Applicant	Pages, Columns, Lines Where Relevant Passages or Relevant Figures Appear	T ¹

NON PATENT LITERATURE DOCUMENTS			
Examiner Initials	Cite No.	Include name of the author (in CAPITAL LETTERS), title of the article (when appropriate), title of the item (book, magazine, journal, serial, symposium, catalog, etc.), date, page(s), volume-issue number(s), publisher, city and/or country where published.	T ¹

23636987

Examiner Signature	<u>/MARJAN FARDANESH/</u>	Date Considered	09/18/2018
<p>*Examiner: Initial if reference considered, whether or not citation is in conformance with MPEP 609. Draw line through citation if not in conformance and not considered. Include copy of this form with next communication to applicant.</p>			

T¹ - Place a check mark in this area when an English language Translation is attached.

ALL REFERENCES CONSIDERED EXCEPT WHERE LINED THROUGH. /M.F/

APL_MAS_ITC_00557138

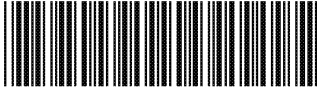
Search Notes 	Application/Control No. 15195199	Applicant(s)/Patent Under Reexamination AL-ALI ET AL.
	Examiner MARJAN FARDANESH	Art Unit 3735

CPC- SEARCHED		
Symbol	Date	Examiner
EAST-See search history printout	9/19/2018	/mf/

CPC COMBINATION SETS - SEARCHED		
Symbol	Date	Examiner

US CLASSIFICATION SEARCHED			
Class	Subclass	Date	Examiner

* See search history printout included with this form or the SEARCH NOTES box below to determine the scope of the search.

SEARCH NOTES		
Search Notes	Date	Examiner
"PALM" inventor name search	9/19/2018	/mf/

INTERFERENCE SEARCH			
US Class/ CPC Symbol	US Subclass / CPC Group	Date	Examiner

/MARJAN FARDANESH/ Examiner, Art Unit 3735	
---	--

<i>Index of Claims</i> 	Application/Control No. 15195199	Applicant(s)/Patent Under Reexamination AL-ALI ET AL.
	Examiner MARJAN FARDANESH	Art Unit 3735

✓	Rejected	-	Cancelled	N	Non-Elected	A	Appeal
=	Allowed	÷	Restricted	I	Interference	O	Objected

Claims renumbered in the same order as presented by applicant
 CPA
 T.D.
 R.1.47

CLAIM		DATE						
Final	Original	09/19/2018						
	1	✓						
	2	✓						
	3	✓						
	4	✓						
	5	✓						
	6	✓						
	7	✓						
	8	✓						
	9	✓						
	10	✓						
	11	✓						
	12	✓						
	13	✓						
	14	✓						
	15	✓						
	16	✓						
	17	✓						
	18	✓						
	19	✓						
	20	✓						
	21	✓						
	22	✓						
	23	✓						
	24	✓						
	25	✓						
	26	✓						
	27	✓						
	28	✓						
	29	✓						
	30	✓						
	31	✓						
	32	✓						
	33	✓						
	34	✓						
	35	✓						
	36	✓						

MAS.1007A

PATENT

IN THE UNITED STATES PATENT AND TRADEMARK OFFICE

First Inventor	:	Ammar Al-Ali
App. No.	:	15/195199
Filed	:	June 28, 2016
For	:	ADVANCED PULSE OXIMETRY SENSOR
Examiner	:	Fardanesh, Marjan
Art Unit	:	3735
Conf. No.	:	3453

RESPONSE TO OFFICE ACTION DATED SEPTEMBER 28, 2018**Mail Stop Amendment**

Commissioner for Patents
P.O. Box 1450
Alexandria, VA 22313-1450

Dear Commissioner:

In response to the Office Action dated September 28, 2018, please consider the following:

Amendments to the Claims are reflected in the listing of claims which begins on page 2 of this paper.

Remarks/Arguments begin on page 9 of this paper.

Application No.: 15/195199
Filing Date: June 28, 2016

AMENDMENTS TO THE CLAIMS

A complete listing of all claims is presented below with insertions underlined (e.g., insertion), and deletions struck through or in double brackets (e.g., ~~deletion~~ or [[deletion]]).

1. **(Currently Amended)** An optical physiological measurement ~~system~~device configured for placement on a patient at a tissue measurement site, the device comprising:

one or more~~[[an]]~~ emitters which emit~~[[s]]~~ light ~~of a wavelength;~~

~~a diffuser which receives, spreads and emits the spread light, wherein the emitted spread light is directed at a tissue measurement site of a patient; and~~

~~[[a]]~~one or more detectors configured to detect the emitted light after attenuation by and reflection from ~~by~~ tissue of the patient at the tissue measurement site, the one or more detectors further configured to transmit a signal responsive to the detected light; and

a light block comprising an annular ring located between the emitted light at the tissue measurement site and the one or more detectors, the light block reducing an amount of incident light emitted from the one or more emitters from being detected by the one or more detectors.

2. **(Currently Amended)** The optical physiological measurement ~~system~~device of Claim ~~[[1]]~~37, further comprising a concentrator which receives the ~~spread~~ light after attenuation by tissue of the patient, concentrates the received ~~spread~~ light and emits the concentrated light in the direction of the one or more detectors.

3. **(Currently Amended)** The optical physiological measurement ~~system~~device of Claim 1, further comprising a processor configured to receive the transmitted signal responsive to the detected light and to determine a physiological parameter.

4. **(Currently Amended)** The optical physiological measurement ~~system~~device of Claim 3, wherein the parameter is arterial oxygen saturation.

5. **(Currently Amended)** The optical physiological measurement ~~system~~device of Claim ~~[[1]]~~37, wherein the diffuser comprises at least one of a glass diffuser, ground glass diffuser, a glass bead diffuser, an opal glass diffuser, and an engineered diffuser.

6. **(Currently Amended)** The optical physiological measurement ~~system~~device of Claim ~~[[1]]~~37, wherein the diffuser emits the spread light with a substantially uniform intensity profile.

Application No.: 15/195199
Filing Date: June 28, 2016

7. **(Currently Amended)** The optical physiological measurement system of Claim ~~[[1]]~~37, wherein the diffuser defines a surface area shape by which the emitted spread light is distributed onto a surface of the tissue measurement site.

8. **(Cancelled)**

9. **(Cancelled)**

10. **(Cancelled)**

11. **(Cancelled)**

12. **(Cancelled)**

13. **(Cancelled)**

14. **(Cancelled)**

15. **(Cancelled)**

16. **(Currently Amended)** The optical physiological measurement ~~system~~device of Claim ~~[[1]]~~2, wherein the concentrator comprises at least one of glass, ground glass, glass beads, opal glass, and a compound parabolic concentrator.

17. **(Cancelled)**

18. **(Currently Amended)** A method to determine a constituent or analyte in a patient's blood, the method comprising:

emitting, from ~~[[an]]~~at least one emitter of an optical sensor, light of ~~[[a]]~~one or more wavelengths;

~~spreading, with a diffuser, the emitted light and emitting the spread light from the diffuser to a tissue measurement site, wherein the diffuser spreads the light over a greater area of the tissue measurement site than would otherwise be illuminated by the emitter directly emitting light at a tissue measurement site; and~~

detecting, with ~~[[the]]~~one or more detectors, the emitted ~~concentrated~~light after attenuation by and reflection from tissue of the patient at the tissue measurement site; and

providing an annular ring located between the emitted light at the tissue measurement site and the one or more detectors, wherein the annular ring reduces an amount of incident light emitted from the at least one emitter from arriving at the one or more detectors.

Application No.: 15/195199
Filing Date: June 28, 2016

19. **(Currently Amended)** The method of Claim [[18]]39, further comprising receiving, by a concentrator, the emitted spread light after the spread light has been attenuated by [[or]]and reflected from the tissue measurement site and concentrating, by the concentrator, the received light and emitting the concentrated light from the concentrator to [[a]]the one or more detectors.

20. **(Currently Amended)** The method of Claim 18, further comprising transmitting, from the one or more detectors, a signal responsive to the detected light; receiving, by a processor, the transmitted signal responsive to the detected light; and processing, by the processor, the received signal responsive to the detected light to determine a physiological parameter.

21. **(Cancelled)**

22. **(Currently Amended)** The method of Claim [[18]]39, wherein spreading, with a diffuser, the emitted light and emitting the spread light from the diffuser to a tissue measurement site is performed by at least one of a glass diffuser, a glass bead diffuser, an opal glass diffuser, and an engineered diffuser.

23. **(Currently Amended)** The method of Claim [[18]]39, wherein spreading, with a diffuser, the emitted light and emitting the spread light from the diffuser to a tissue measurement site further comprises spreading the emitted light with a substantially uniform intensity profile.

24. **(Currently Amended)** The method of Claim [[18]]39, wherein spreading, with a diffuser, the emitted light and emitting the spread light from the diffuser to a tissue measurement site further comprises spreading the emitted light so as to define a surface area shape by which the emitted spread light is distributed onto a surface of the tissue measurement site.

25. **(Currently Amended)** The method of Claim [[18]]19, wherein concentrating, by the concentrator, the received light and emitting the concentrated light from the concentrator to [[a]]the one or more detectors is performed by at least one of a glass concentrator, a glass bead concentrator, an opal glass concentrator, and a compound parabolic concentrator.

26. **(Currently Amended)** A pulse oximeter sensor comprising:

~~an emitter~~ one or more optical sources configured to emit light at [[a]]one or more wavelengths, wherein, when the pulse oximeter sensor is placed on a patient at a tissue

Application No.: 15/195199
Filing Date: June 28, 2016

measurement site, the one or more optical sources are positioned in a reflectance measurement configuration on a first side of the tissue measurement site;

~~a diffuser configured to receive the emitted light, to spread the received light, and to emit the spread light, wherein the emitted spread light is directed at a tissue measurement site; and~~

a detector plurality of detectors configured to detect the emitted spread light, the spread light emitted from the one or more optical sources after having been attenuation[[ed]]by tissue of the patient at the tissue measurement site, the plurality of detectors arranged in an array so as to capture the emitted light reflected from the tissue of the patient at [[by]]the tissue measurement site, wherein the plurality of detectors are positioned in a reflectance measurement configuration on the first side of the tissue measurement site when the pulse oximeter sensor is placed on the patient, the plurality of detectors detector further configured to output a signal responsive to the detected light; and

a light block comprising an annular ring located between the emitted light at the tissue measurement site and the plurality of detectors, the light block reducing an amount of incident light emitted from the one or more optical sources from arriving at the plurality of detectors.

27. **(Currently Amended)** The pulse oximeter sensor of Claim 26, further comprising a concentrator which concentrates the emitted light after it has been attenuated by the tissue measurement site and directs the concentrated light toward the plurality of detectors.

28. **(Currently Amended)** The pulse oximeter sensor of Claim 26, wherein the plurality of detectors ~~[[is]]are~~ further configured to output the signals response to the detected light to a processor configured to receive the signals responsive to the detected light and to determine a physiological parameter.

29. **(Currently Amended)** The pulse oximeter sensor of Claim ~~[[26]]41~~, wherein the diffuser is further configured to define a surface area shape by which the emitted spread light is distributed onto a surface of the tissue measurement site.

30. **(Cancelled)**

31. **(Cancelled)**

Application No.: 15/195199
Filing Date: June 28, 2016

32. **(Currently Amended)** A pulse oximeter sensor comprising:

~~an emitter~~ one or more optical sources configured to emit light at [[a]]one or more wavelengths, wherein, when the pulse oximeter sensor is placed on a patient at a tissue measurement site, the one or more optical sources are positioned in a reflectance measurement configuration on a first side of the tissue measurement site;

~~a concentrator which concentrates the emitted light after it has been attenuated by the tissue measurement site; and~~

~~a detector~~ plurality of detectors configured to detect the emitted spread, the spread light emitted from the one or more optical sources after having been attenuation[[ed]] by and reflection from[[by]] tissue of the patient at ~~or reflected from~~ the tissue measurement site, wherein the plurality of detectors are positioned in a reflectance measurement configuration on the first side of the tissue measurement site when the pulse oximeter sensor is placed on the patient, the plurality of detectors further configured to output [[a]]signals responsive to the detected light; and

a light block comprising an annular ring located between the emitted light at the tissue measurement site and the plurality of detectors, the light block reducing an amount of incident light emitted from the one or more optical sources that does not enter the tissue measurement site arriving at the plurality of detectors.

33. **(Currently Amended)** The pulse oximeter sensor of Claim 32, wherein the plurality of detectors ~~[[is]]~~ are further configured to transmit the output signals responsive to the detected light to a processor configured to receive the signals responsive to the detected light and to determine a physiological parameter.

34. **(Cancelled)**

35. **(Cancelled)**

36. **(Cancelled)**

37. **(New)** The optical physiological measurement device of Claim 1, further comprising a diffuser which receives, spreads and emits the spread light, wherein the emitted spread light is directed at the tissue measurement site.

38. **(New)** The optical physiological measurement device of Claim 1, wherein the emitter is positioned outside the annular ring when the optical physiological measurement device

Application No.: 15/195199
Filing Date: June 28, 2016

is placed on the patient at the tissue measurement site, and wherein the one or more detectors are positioned inside the annular ring when the optical physiological measurement device is placed on the patient at the tissue measurement site.

39. **(New)** The method of Claim 18, further comprising spreading, with a diffuser, the emitted light and emitting the spread light from the diffuser to the tissue measurement site, wherein the diffuser spreads the light over a greater area of the tissue measurement site than would otherwise be illuminated by the emitter directly emitting light at the tissue measurement site.

40. **(New)** The method of Claim 18, wherein the emitter is positioned outside the annular ring when the optical sensor is placed on the patient at the tissue measurement site, and wherein the one or more detectors are positioned inside the annular ring when the optical sensor is placed on the patient at the tissue measurement site.

41. **(New)** The pulse oximeter sensor of Claim 26, further comprising a diffuser configured to receive the emitted light, to spread the received light, and to emit the spread light, wherein the emitted spread light is directed at the tissue measurement site.

42. **(New)** The pulse oximeter sensor of Claim 26, wherein the one or more optical sources are positioned outside the annular ring when the pulse oximeter sensor is placed on the patient at the tissue measurement site, and wherein the plurality of detectors are positioned inside the annular ring when the pulse oximeter sensor is placed on the patient at the tissue measurement site.

43. **(New)** The pulse oximeter sensor of Claim 26, wherein the plurality of detectors are arranged in an array with a special configuration corresponding to an irradiated surface area.

44. **(New)** The pulse oximeter sensor of Claim 43, wherein the irradiated surface area comprises an annular shape.

45. **(New)** The pulse oximeter sensor of Claim 32, wherein the one or more optical sources are positioned outside the annular ring when the pulse oximeter sensor is placed on the patient at the tissue measurement site, and wherein the plurality of detectors are positioned inside the annular ring when the pulse oximeter sensor is placed on the patient at the tissue measurement site.

Application No.: 15/195199
Filing Date: June 28, 2016

46. **(New)** The pulse oximeter sensor of Claim 32, wherein the plurality of detectors are arranged in an array so as to capture the emitted light reflected by tissue of the patient at the tissue measurement site.

47. **(New)** The pulse oximeter sensor of Claim 46, wherein the plurality of detectors are arranged in an array with a special configuration corresponding to an irradiated surface area.

48. **(New)** The pulse oximeter sensor of Claim 47, wherein the irradiated surface area comprises an annular shape.

Application No.: 15/195199
Filing Date: June 28, 2016

REMARKS

This paper is filed in response to the Office Action mailed September 28, 2018 (“Office Action”), in connection with the above-referenced patent application. Claims 1-36 were pending prior to the submission of this paper. Claims 1-7, 16, 18-20, 22-29, and 32-33 have been amended and Claims 8-15, 17, 21, 30-31, and 34-36 have been cancelled without prejudice or disclaimer. Thus, Claims 1-7, 16, 18-20, 22-29, 32-33, and 37-48 are pending. Applicant respectfully requests allowance of the pending claims in light of the present response.

A. Claim Objection

The Office Action asserted that Claim 26 was a duplicate of Claim 1. Without necessarily agreeing with this assertion, Applicant believes this objection is moot in view of the amendments shown above and respectfully requests that this objection be withdrawn.

B. Claim Rejection under 35 U.S.C. § 112

The Office Action rejected Claim 32 as being allegedly incomplete for omitting essential elements. Without necessarily agreeing with this assertion, Applicant believes this objection is moot in view of the amendments shown above and respectfully requests that this rejection be withdrawn.

C. The Pending Claims Are Patentable over the Cited Art

Independent Claims 1, 18, and 26 and dependent Claims 3, 4, 6, 7, 9-14, 20, 23, 24, 26, 28, and 29 were rejected under 35 U.S.C. § 102 as allegedly being anticipated by U.S. Patent No. 6,343,223 to Chin et al (hereinafter “Chin”). Independent Claims 1, 18, 26, and 32 and dependent Claims 2, 5-9, 15-17, 19, 21-25, 27, 30-31, and 33-36 were rejected under 35 U.S.C. § 102 as allegedly being anticipated by U.S. Patent Pub. No. 2004/0114783 to Spycher et al (“Spycher”). Applicant respectfully disagrees and requests that the rejections of Claims 1-7, 16, 18, 19, 22-29, 32-33 be withdrawn and new Claims 37-48 be allowed for at least the following reasons.

1. Independent Claim 1

Amended Claim 1 recites:

An optical physiological measurement device configured for placement on a patient at a tissue measurement site, the device comprising:

one or more emitters which emit light;

one or more detectors configured to detect the emitted light after attenuation by and reflection from tissue of the patient at the tissue measurement site, the one or more detectors further configured to transmit a signal responsive to the detected light; and

Application No.: 15/195199
Filing Date: June 28, 2016

a light block comprising an annular ring located between the emitted light at the tissue measurement site and the one or more detectors, the light block reducing an amount of incident light emitted from the one or more emitters from being detected by the one or more detectors.

Applicant respectfully submits that the cited art, alone or in combination, fails to teach or suggest the above-recited limitations of Claim 1. For at least these reasons, Applicant respectfully requests withdrawal of the rejection of independent Claim 1 and allowance of the claim.

2. Independent Claim 18

Amended Claim 18 recites:

A method to determine a constituent or analyte in a patient's blood, the method comprising:

emitting, from at least one emitter of an optical sensor, light of one or more wavelengths;

detecting, with one or more detectors, the emitted light after attenuation by and reflection from tissue of the patient at the tissue measurement site; and

providing an annular ring located between the emitted light at the tissue measurement site and the one or more detectors, wherein the annular ring reduces an amount of incident light emitted from the at least one emitter from arriving at the one or more detectors.

Applicant respectfully submits that the cited art, alone or in combination, fails to teach or suggest the above-recited limitations of Claim 18. For at least these reasons, Applicant respectfully requests withdrawal of the rejection of independent Claim 18 and allowance of the claim.

3. Independent Claim 26

Amended Claim 26 recites:

A pulse oximeter sensor comprising:

one or more optical sources configured to emit light at one or more wavelengths, wherein, when the pulse oximeter sensor is placed on a patient at a tissue measurement site, the one or more optical sources are positioned in a reflectance measurement configuration on a first side of the tissue measurement site;

a plurality of detectors configured to detect light emitted from the one or more optical sources after attenuation by tissue of the patient at the tissue measurement site, the plurality of detectors arranged in an array so as to capture the emitted light reflected from the tissue of the patient at the tissue measurement site, wherein the plurality of detectors are positioned in a reflectance measurement configuration on the first side of the tissue measurement site when the pulse oximeter sensor is placed on the patient, the plurality of detectors further configured to output a signal responsive to the detected light; and

Application No.: 15/195199
Filing Date: June 28, 2016

a light block comprising an annular ring located between the emitted light at the tissue measurement site and the plurality of detectors, the light block reducing an amount of incident light emitted from the one or more optical sources from arriving at the plurality of detectors.

Applicant respectfully submits that the cited art, alone or in combination, fails to teach or suggest the above-recited limitations of Claim 26. For at least these reasons, Applicant respectfully requests withdrawal of the rejection of independent Claim 26 and allowance of the claim.

4. Independent Claim 32

Amended Claim 32 recites:

A pulse oximeter sensor comprising:

one or more optical sources configured to emit light at one or more wavelengths, wherein, when the pulse oximeter sensor is placed on a patient at a tissue measurement site, the one or more optical sources are positioned in a reflectance measurement configuration on a first side of the tissue measurement site;

a plurality of detectors configured to detect light emitted from the one or more optical sources after attenuation by and reflection from tissue of the patient at the tissue measurement site, wherein the plurality of detectors are positioned in a reflectance measurement configuration on the first side of the tissue measurement site when the pulse oximeter sensor is placed on the patient, the plurality of detectors further configured to output signals responsive to the detected light; and

a light block comprising an annular ring located between the emitted light at the tissue measurement site and the plurality of detectors, the light block reducing an amount of incident light emitted from the one or more optical sources that does not enter the tissue measurement site arriving at the plurality of detectors.

Applicant respectfully submits that the cited art, alone or in combination, fails to teach or suggest the above-recited limitations of Claim 32. For at least these reasons, Applicant respectfully requests withdrawal of the rejection of independent Claim 32 and allowance of the claim.

5. Dependent Claims 2-7, 16, 19-20, 22-25, 27-29, and 33

Claims 2-7, 16, 19-20, 22-25, 27-29, and 33 depend directly or indirectly from Claims 1, 18, 26, or 32 and are thus patentably distinct from the cited art of record for at least the reasons set forth above in regard to Claims 1, 18, 26, or 32. In addition, Applicant notes that these claims, when taken in the context of Claims 1, 18, 26, or 32, set forth a number of recitations not taught, disclosed, or suggested by the cited references, alone or in combination. For at least these

Application No.: 15/195199
Filing Date: June 28, 2016

additional reasons, Applicant respectfully requests that the rejections of Claims 2-7, 16, 19-20, 22-25, 27-29, and 33 be withdrawn and the claims allowed.

6. New Claims 37-48

Claims 37-48 were added in the present paper and our believed to be patentable over the cited art. Accordingly, Applicant respectfully requests that Claims 37-48 be indicated as allowable.

D. No Disclaimers or Disavowals

Although the present communication may include alterations to the application or claims, or characterizations of claim scope or referenced art, Applicant is not conceding in this application that previously pending claims are not patentable over the cited references. Rather, any alterations or characterizations are being made to facilitate expeditious prosecution of this application. Applicant reserves the right to pursue at a later date any previously pending or other broader or narrower claims that capture any subject matter supported by the present disclosure, including subject matter found to be specifically disclaimed herein or by any prior prosecution. Accordingly, reviewers of this or any parent, child or related prosecution history shall not reasonably infer that Applicant has made any disclaimers or disavowals of any subject matter supported by the present application.

Please charge any additional fees, including any fees for additional extension of time, or credit overpayment to Deposit Account No. 11-1410.

Respectfully submitted,

KNOBBE, MARTENS, OLSON & BEAR, LLP

Dated: November 6, 2018

By: /Aaron S. Johnson/
Aaron S. Johnson
Registration No. 74,164
Registered Practitioner
Customer No. 64735
(949) 760-0404

-12-

APL_MAS_ITC_00557152

Electronic Acknowledgement Receipt	
EFS ID:	34222564
Application Number:	15195199
International Application Number:	
Confirmation Number:	3453
Title of Invention:	ADVANCED PULSE OXIMETRY SENSOR
First Named Inventor/Applicant Name:	Ammar Al-Ali
Customer Number:	64735
Filer:	Aaron Samuel Johnson/Imran Ahmed
Filer Authorized By:	Aaron Samuel Johnson
Attorney Docket Number:	MAS.1007A
Receipt Date:	06-NOV-2018
Filing Date:	28-JUN-2016
Time Stamp:	13:19:19
Application Type:	Utility under 35 USC 111(a)

Payment information:

Submitted with Payment	no
------------------------	----

File Listing:

Document Number	Document Description	File Name	File Size(Bytes)/ Message Digest	Multi Part /.zip	Pages (if appl.)
1		OAR_MAS1007A.pdf	64465 ca3dabe16a48f490aafe8704df102fc1ecc6304	yes	12

Multipart Description/PDF files in .zip description			
Document Description		Start	End
Amendment/Req. Reconsideration-After Non-Final Reject		1	1
Claims		2	8
Applicant Arguments/Remarks Made in an Amendment		9	12
Warnings:			
Information:			
Total Files Size (in bytes):		64465	
<p>This Acknowledgement Receipt evidences receipt on the noted date by the USPTO of the indicated documents, characterized by the applicant, and including page counts, where applicable. It serves as evidence of receipt similar to a Post Card, as described in MPEP 503.</p> <p><u>New Applications Under 35 U.S.C. 111</u> If a new application is being filed and the application includes the necessary components for a filing date (see 37 CFR 1.53(b)-(d) and MPEP 506), a Filing Receipt (37 CFR 1.54) will be issued in due course and the date shown on this Acknowledgement Receipt will establish the filing date of the application.</p> <p><u>National Stage of an International Application under 35 U.S.C. 371</u> If a timely submission to enter the national stage of an international application is compliant with the conditions of 35 U.S.C. 371 and other applicable requirements a Form PCT/DO/EO/903 indicating acceptance of the application as a national stage submission under 35 U.S.C. 371 will be issued in addition to the Filing Receipt, in due course.</p> <p><u>New International Application Filed with the USPTO as a Receiving Office</u> If a new international application is being filed and the international application includes the necessary components for an international filing date (see PCT Article 11 and MPEP 1810), a Notification of the International Application Number and of the International Filing Date (Form PCT/RO/105) will be issued in due course, subject to prescriptions concerning national security, and the date shown on this Acknowledgement Receipt will establish the international filing date of the application.</p>			

Under the Paperwork Reduction Act of 1995, no persons are required to respond to a collection of information unless it displays a valid OMB control number.

PATENT APPLICATION FEE DETERMINATION RECORD Substitute for Form PTO-875	Application or Docket Number 15/195,199	Filing Date 06/28/2016	<input type="checkbox"/> To be Mailed
---	---	----------------------------------	---------------------------------------

ENTITY: LARGE SMALL MICRO

APPLICATION AS FILED – PART I

FOR	NUMBER FILED (Column 1)	NUMBER EXTRA (Column 2)	RATE (\$)	FEE (\$)
<input type="checkbox"/> BASIC FEE (37 CFR 1.16(a), (b), or (c))	N/A	N/A	N/A	
<input type="checkbox"/> SEARCH FEE (37 CFR 1.16(k), (j), or (m))	N/A	N/A	N/A	
<input type="checkbox"/> EXAMINATION FEE (37 CFR 1.16(o), (p), or (q))	N/A	N/A	N/A	
TOTAL CLAIMS (37 CFR 1.16(i))	minus 20 =	*	X \$ =	
INDEPENDENT CLAIMS (37 CFR 1.16(h))	minus 3 =	*	X \$ =	
<input type="checkbox"/> APPLICATION SIZE FEE (37 CFR 1.16(s))	If the specification and drawings exceed 100 sheets of paper, the application size fee due is \$310 (\$155 for small entity) for each additional 50 sheets or fraction thereof. See 35 U.S.C. 41(a)(1)(G) and 37 CFR 1.16(s).			
<input type="checkbox"/> MULTIPLE DEPENDENT CLAIM PRESENT (37 CFR 1.16(j))				
* If the difference in column 1 is less than zero, enter "0" in column 2.				TOTAL

APPLICATION AS AMENDED – PART II

AMENDMENT	11/06/2018	CLAIMS REMAINING AFTER AMENDMENT	HIGHEST NUMBER PREVIOUSLY PAID FOR	PRESENT EXTRA	RATE (\$)	ADDITIONAL FEE (\$)
	Total (37 CFR 1.16(i))	* 33	Minus	** 36	= 0	X \$100 = 0
	Independent (37 CFR 1.16(h))	* 4	Minus	***4	= 0	X \$460 = 0
	<input type="checkbox"/> Application Size Fee (37 CFR 1.16(s))					
	<input type="checkbox"/> FIRST PRESENTATION OF MULTIPLE DEPENDENT CLAIM (37 CFR 1.16(j))					
TOTAL ADD'L FEE						0

AMENDMENT	CLAIMS REMAINING AFTER AMENDMENT	HIGHEST NUMBER PREVIOUSLY PAID FOR	PRESENT EXTRA	RATE (\$)	ADDITIONAL FEE (\$)
	Total (37 CFR 1.16(i))	*	Minus	**	=
	Independent (37 CFR 1.16(h))	*	Minus	***	=
	<input type="checkbox"/> Application Size Fee (37 CFR 1.16(s))				
	<input type="checkbox"/> FIRST PRESENTATION OF MULTIPLE DEPENDENT CLAIM (37 CFR 1.16(j))				
TOTAL ADD'L FEE					

* If the entry in column 1 is less than the entry in column 2, write "0" in column 3.
 ** If the "Highest Number Previously Paid For" IN THIS SPACE is less than 20, enter "20".
 *** If the "Highest Number Previously Paid For" IN THIS SPACE is less than 3, enter "3".
 The "Highest Number Previously Paid For" (Total or Independent) is the highest number found in the appropriate box in column 1.

LIE
 CHERYL CLARK

This collection of information is required by 37 CFR 1.16. The information is required to obtain or retain a benefit by the public which is to file (and by the USPTO to process) an application. Confidentiality is governed by 35 U.S.C. 122 and 37 CFR 1.14. This collection is estimated to take 12 minutes to complete, including gathering, preparing, and submitting the completed application form to the USPTO. Time will vary depending upon the individual case. Any comments on the amount of time you require to complete this form and/or suggestions for reducing this burden, should be sent to the Chief Information Officer, U.S. Patent and Trademark Office, U.S. Department of Commerce, P.O. Box 1450, Alexandria, VA 22313-1450. DO NOT SEND FEES OR COMPLETED FORMS TO THIS ADDRESS. **SEND TO: Commissioner for Patents, P.O. Box 1450, Alexandria, VA 22313-1450.**
 If you need assistance in completing the form, call 1-800-PTO-9199 and select option 2.

PTO/SB/08 Equivalent

INFORMATION DISCLOSURE STATEMENT BY APPLICANT	Application No.	15/195199	
	Filing Date	June 28, 2016	
	First Named Inventor	Ammar Al-Ali	
	Art Unit	3735	
<i>(Multiple sheets used when necessary)</i>		Examiner	Fardanesh, Marjan
SHEET 1 OF 1		Attorney Docket No.	MAS.1007A

U.S. PATENT DOCUMENTS					
Examiner Initials	Cite No.	Document Number <i>Number - Kind Code (if known)</i> Example: 1,234,567 B1	Publication Date MM-DD-YYYY	Name	Pages, Columns, Lines Where Relevant Passages or Relevant Figures Appear
	1	6,671,526 B1	12/30/2003	Aoyagi et al.	
	2	2004/0054290 A1	03/18/2004	Chance	
	3	2011/0004106 A1	01/06/2011	Iwamiya et al.	
	4	2011/0085721 A1	04/14/2011	Guyon et al.	

FOREIGN PATENT DOCUMENTS						
Examiner Initials	Cite No.	Foreign Patent Document <i>Country Code-Number-Kind Code</i> Example: JP 1234567 A1	Publication Date MM-DD-YYYY	Name	Pages, Columns, Lines Where Relevant Passages or Relevant Figures Appear	T ¹
	5	EP 0781527 A1	07/02/1997	INSTRUMENTARIUM OY		
	6	EP 2277440 A1	01/26/2011	PIONEER CORP		

NON PATENT LITERATURE DOCUMENTS			
Examiner Initials	Cite No.	Include name of the author (in CAPITAL LETTERS), title of the article (when appropriate), title of the item (book, magazine, journal, serial, symposium, catalog, etc.), date, page(s), volume-issue number(s), publisher, city and/or country where published.	T ¹
	7	Written Opinion received in International Application No. PCT/US2016/040190, dated January 2, 2018.	

29343450

Examiner Signature	Date Considered
<p>*Examiner: Initial if reference considered, whether or not citation is in conformance with MPEP 609. Draw line through citation if not in conformance and not considered. Include copy of this form with next communication to applicant.</p>	

T¹ - Place a check mark in this area when an English language Translation is attached.

(19)  **Europäisches Patentamt**
European Patent Office
Office européen des brevets



(11) **EP 0 781 527 A1**

(12) **EUROPEAN PATENT APPLICATION**

(43) Date of publication: **02.07.1997 Bulletin 1997/27** (51) Int Cl.⁶: **A61B 5/00, G02B 6/36**
 (21) Application number: **96660092.6**
 (22) Date of filing: **27.11.1996**

<p>(84) Designated Contracting States: DE FR GB IT SE</p> <p>(30) Priority: 29.11.1995 FI 955758</p> <p>(71) Applicant: Instrumentarium Oy SF-00510 Helsinki (FI)</p> <p>(72) Inventors: <ul style="list-style-type: none"> Weckström, Kurt Peter 02170 Espoo (FI) </p>	<ul style="list-style-type: none"> Ristolainen, Kimmo Juhani 00970 Helsinki (FI) <p>(74) Representative: Laako, Tero Jussi Berggren Oy Ab P.O. Box 16 00101 Helsinki (FI)</p>
---	--

(54) **Pulsoximeter sensor**

(57) The invention relates to a pulsoximeter sensor for measuring the degree of oxygen saturation in a patient's blood non-invasively. A sensor (100) comprises: radiation sources (38), which emit measuring radiation with at least two wavelengths to a portion (6) of the body of a patient; a detector (37) for receiving the measuring radiation having passed through said body portion of a patient and for converting the same to electric form; as well as at least one radiation transfer section, which is

located between either the radiation sources or respectively the detectors and the external surface (50) of said body portion of a patient. The radiation transfer section includes measuring-radiation transmitting ends, whereof an outer end (16; 26) facing the external body surface (50) has a surface area which is generally larger than the surface area of an inner end (13a; 19a) facing any given radiation sources or respectively detectors, as well as a measuring-radiation diffusively reflecting surface (14, 17) between these ends.

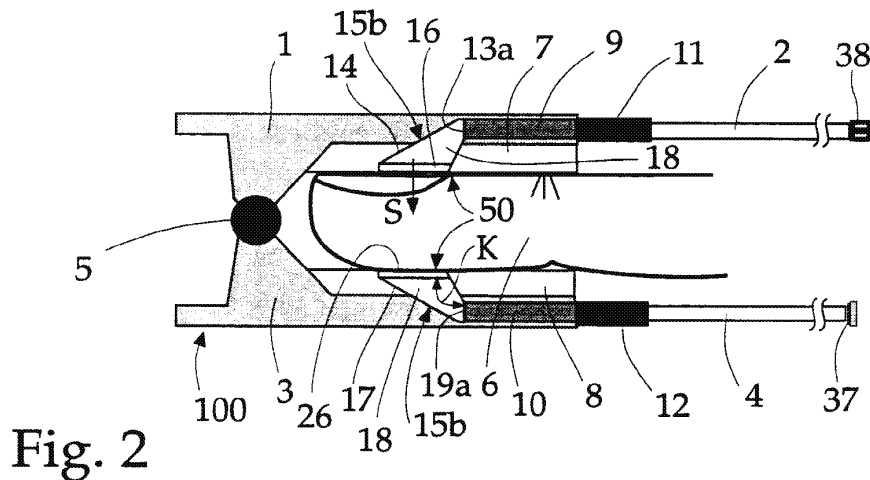

EP 0 781 527 A1

Description

The present invention relates to a pulsoximeter for measuring the degree of oxygen saturation in a patient's blood non-invasively, said sensor comprising: a radiation source or radiation sources for emitting measuring radiation with at least two wavelengths to a portion of the body of a patient; detectors or respectively a detector for receiving measuring radiation transmitted through said body portion of a patient and for transforming the same to electrical form; at least one radiation transfer section which is located between either the radiation sources or respectively the detectors and the external surface of said body portion. The invention relates also to the use of such a sensor.

Pulsoximeters are capable of measuring the degree of oxygen saturation in a patient's blood non-invasively and continuously. The term non-invasive indicates that the patient is not subjected to subcutaneous penetration by any physical means but the measuring is effected by means of radiation and other than that the procedure occurs externally of the body. This type of monitoring of blood oxygen saturation is quite common today and is one of the monitoring parameters required in many applications. The measurement is optical and based on various absorption characteristics of red and infrared light in blood hemoglobin. The principles of pulsoximetry are disclosed e.g. in Patent publication JP-53-26437. This reference describes a pulsoximeter sensor which comprises a wide-band thermic radiation source and two optical detectors fitted with a bandpass filter for expressing various wavelengths. At present, the pulsoximeter sensors include two light sources, which are typically light emitting diodes (LED), and a single detector, and the radiation sources are operated alternately in synchronism. In each case, the radiation sources and detectors are included in the sensor itself near a target to be measured and from the sensor extend electrical cables to a control monitor. Usually, the patient experiences no problems when using high-efficiency light sources with a low power consumption. However, the signal-to-noise ratio may sometimes suffer, particularly if for some reason it is desirable to use wavelengths other than those provided by said light sources. In order to achieve as powerful a signal as possible, the light sources can be supplied with a lot of electric power. This may sometimes lead to the situation that, as a result of a higher input of power, the heat generated by light sources affects a target to be measured and causes even burns. Thus, in practice, there is sometimes no choice but to settle for quite a poor signal when sufficient light cannot be produced without coincident heat generation. Neither can the above-described conventional solution be used for example during the course of currently more and more popular magnetic imaging of a patient or while operating some other powerful electromagnetic source. In these conditions, the electrical cable of a sensor would act as an antenna for interferences originating from a

control monitor and these interferences would upset the magnetic images. Also other metallic parts at the sensor end disturb a magnetic imager and distort the imaging result. Also in the imaging field, the electric conductor of a sensor may be induced with currents sufficiently strong for a patient to sustain burns or to break down the pulsoximeter equipment. In order to secure its immaculate operation in magnetic imaging environment, the oximeter sensor must not include any metallic components at all and, thus, all normal electronics must also be excluded.

The pulsoximeter sensors compatible with magnetic imaging environment are typically designed with fiberoptics. Hence, the light sources and detector are spaced away from an actual site to be imaged. The light supply is led to and from a site to be measured along optical fibers. In practice, the fiberoptic cable is a bundle of fibers, comprising a plurality of thin optical fibers and having typically a diameter of 1-3 mm. In order to develop a clinically useful sensor, it is necessary in many cases to bring the bundles of optical fibers to the sensor end in the direction at least roughly parallel to sensor housings. This requires that the light supply be deflected by about 90° inside the sensor housing. The light supply can be deflected by bending the optical fibers to a 90° angle, as disclosed in the publication MEDICAL & BIOLOGICAL ENGINEERING & COMPUTING, Vol. 18 /1980 pp. 27 - 32: Yoshiya, Shimada, Tanaka - "Spectrophotometric monitoring of arterial oxygen saturation in the fingertip". In terms of production, however, this solution is difficult to carry out with sufficiently large bundles of fibers and with a sufficiently small bending radius. The cited glass fibers are easily broken upon bending. Likewise, some of the light supply manages to escape out of the fibers at a sharp curve formed in the fibers.

Other representative fiberoptic designs for a pulsoximeter sensor are described in publications US-5,279,295 and WO-92/21281. In both solutions, the end of a fiber bundle is more or less bent for guiding a light signal to and from a target. In each case, the object of measuring is a patient's finger. In publication US-5,279,295, the monitoring is based on the reflection of light from the finger while publication WO-92/21281 discloses a more conventional solution, wherein the finger is radiographed. In publication WO-92/21281, the material of a fiberoptic radiation guide is determined to be plastics, i.e. the question is about a plastic fiber, which is probably a little more resistant to bending than glass fiber. However, a drawback in the plastic fiber is that, as pointed out in the publication, its transmittance does not extend very deep into the infrared range, which prevents the use of wavelengths that would be optimal in terms of measuring and also the use of best possible radiation emitting diodes (LED). In these solutions, as well, some radiation may escape out of the sharp fiber curve. The described solutions provide a signal which is poorer than what is achieved if a straight bundle of fibers were

orthogonal to the target. Furthermore, the bending of a bundle of fibers is an expensive approach in terms of productivity. A bundle of fibers in the proximity of a target represents a relatively small surface area. A result of this is that the sensor is sensitive to a so-called motion-related artefact. These result either directly from the movements of a target relative to the sensor or from volumetric changes, i.e. absorbency changes, introduced in venous blood by external causes. The harmful effect is further enhanced by the fact that the numerical fiber aperture is relatively small. Normally, a bundle of fibers accepts light rays within the range of $\pm 40^\circ$ or at best $\pm 60^\circ$ with respect to the fiber axis. This is modest with respect to a conventional sensor, wherein the source radiates in principle $\pm 90^\circ$ and also the detector accepts the same amount.

The direction of light supply can also be deflected by means of some external structure, for example a reflective mirror surface. The reflective mirror surface is created e.g. by metallizing a shiny plastic surface. However, a metallic mirror is not capable of deflecting all radiation supply coming from the fibers. Similarly, a metallic mirror is inconvenient in coupling a sufficient amount of tissue-penetrated radiation with a second bundle of fibers and further with the detector. Another downside in a metallic mirror is a metallic layer included therein, which, as a result of evolving eddy currents, may warm up during magnetic imaging and expose the patient to burn hazards. Furthermore, as described above, a metallic layer may disturb magnetic imaging.

A first object of this invention is to provide a pulseoximeter sensor, wherein at least one radiation source or at least one bundle of fibers can be used for supplying a target with radiation and/or radiation can be collected from a target to at least one detector or at least one bundle of fibers effectively, advantageously and compactly, which particularly means a high efficiency in the transmission of radiation. A second object of the invention is to provide a pulseoximeter sensor which is not highly sensitive to a motion-related artefact. A third object of the invention is to provide a pulseoximeter sensor, wherein the heat generated by light sources does not reach a target to be measured but, as a result of the configuration, can be led away therefrom which, if necessary, enables the use of high-power radiation sources. A fourth object of the invention is this type of pulseoximeter sensor which does not restrict too severely the use of an otherwise desired infrared wavelength range.

The above-described drawbacks can be eliminated and the above-defined objects can be achieved by means of a pulseoximeter sensor of the invention, which is characterized by what is set forth in the characterizing clauses of claims 1 and 6 and by the use of such a sensor, said use being characterized by what is set forth in the characterizing clause of claim 13.

In an apparatus of the invention, the light supply can be effectively collected and, if necessary, deflected inside a sensor housing by means of a diffusively reflect-

ing surface. Measuring tests have indicated that, when using this diffusively reflecting surface of the invention in association with optical fibers, the resulting signal is even substantially stronger than that produced by means of target-attached straight or bent fibers. This apparent paradox is explainable by the fact that it is possible to employ larger target areas, as will be manifested hereinbelow. The solution is beneficial since the required materials are inexpensive and it occupies little space since the bundle of fibers need not be bent. In addition, it is possible to employ reasonably priced standard straight fiber bundles instead of expensive and damage-prone special designs. In the proximity of a target to be measured, the light apertures are sufficiently large, such that light can be delivered to the target consistently and also collected therefrom consistently over an area larger than the fiber diameter. By virtue of this, the sensitivity to a motion-related artefact will be insignificant. Conditions permitting, a diffusively reflecting surface of the invention can be used without optical fibers in a sensor equipped with light sources and a detector. Thus, it is preferred that the side facing light sources be provided with a diffusively reflecting surface. This way the light sources are brought further away from a target to be measured and the heat generated thereby is easily carried away from the target.

The invention will now be described in detail with reference made to the accompanying drawing figures.

Fig. 1 is a plan view of a typical embodiment for a pulseoximeter sensor of the invention, which is fitted with optical fibers for the transfer of radiation and a measuring signal and, thus, for spacing a radiation source and detectors from a sensor itself and which is designed to be fitted on a finger and to operate on a finger-penetrating measuring technique.

Fig. 2 is a lengthwise cross-section along a plane I-I in fig. 1, showing a first embodiment for a pulseoximeter sensor of the invention, employing fiberoptics for spacing radiation sources and a detector from the actual sensor.

Fig. 3 is a lengthwise cross-section along a plane I-I in fig. 1, showing a second embodiment for a pulseoximeter sensor of the invention, employing fiberoptics for spacing radiation sources and a detector from the actual sensor.

Fig. 4 shows graphically the reflection characteristics of diffusively reflective surfaces of the invention.

Fig. 5A and 5B depict the behaviour of a diffusively reflective surface of the invention with radiation arriving thereon from various angles of incidence.

Fig. 6 is a lengthwise cross-section, in a view similar to figs. 2 and 3, showing a third embodiment for a pulseoximeter sensor of the invention, wherein light sources are located remotely from a target to be measured and electric current is brought to and a signal delivered from the sensor along electric conductors.

Fig. 7 is a lengthwise cross-section, in a view similar to figs. 2 and 3, showing a fourth embodiment for a pul-

soximeter sensor of the invention, wherein light sources are located remotely from a target to be measured and electric current is brought to and a signal delivered from the sensor along electric conductors.

Fig. 8 is a lengthwise cross-section, in a view similar to figs. 2 and 3, showing a fifth embodiment for a pulsoximeter sensor of the invention, wherein a detector is located remotely from a target to be measured and electric current is brought to and a signal delivered from the sensor along electric conductors.

Fig. 9 is a lengthwise cross-section, in a view similar to figs. 2 and 3, showing a sixth embodiment for a pulsoximeter sensor of the invention, wherein a detector is located remotely from a target to be measured and electric current is brought to and a signal delivered from the sensor along electric conductors.

Fig. 10 is a lengthwise cross-section, corresponding to the view of figs. 2-9, showing a seventh embodiment for a pulsoximeter sensor of the invention, wherein a detector is located remotely from a target to be measured and electric current is brought to and a signal delivered from the sensor along electric conductors and which is designed to be placed on the surface of a patient's body for a measuring technique effected by reflecting from a patient's tissue.

Fig. 11 is a lengthwise cross-section, in a view similar to figs. 2 and 3, showing an eighth embodiment for a pulsoximeter sensor of the invention, wherein a detector is located remotely from a target to be measured and electric current is brought to and a signal delivered from the sensor along electric conductors and which is designed to be placed on the surface of a patient's body for a measuring technique effected by reflecting from a patient's tissue.

Fig. 12 shows in principle the relative position of those radiation-transmissive end walls whereby the measuring radiation arrives on a diffusively reflective surface of the invention.

Fig. 13 shows in principle the first relative directions of the principal radiating direction for a radiation source assembly of the invention and the principal sensitivity direction for a detector assembly of the invention, corresponding to the embodiments of figs. 2-9.

Fig. 14 shows in principle the second relative directions of the principal radiating direction for a radiation source assembly of the invention and the principal sensitivity direction for a detector assembly of the invention, corresponding to the embodiments of figs. 10 and 11.

A typical pulsoximeter sensor is attached to a fingertip as shown in fig. 1. In this application, the expressions radiation and light are used for representing the same thing, i.e. an electromagnetic radiation regardless of a wavelength. In this embodiment, the radiation or light arrives in a top sensor portion 1 along a fiberoptic cable 2 and a light 54 having passed through the finger is collected in a bottom sensor portion 3 for delivering it therefrom along a fiberoptic cable 4 to a detector. In commercially available sensors, the light source gener-

ally comprises two diodes (LED) emitting at different wavelengths and the detection of light is generally effected e.g. by means of a single silicon detector, since the applied wavelengths remain within its sensitivity range. Thus, the two radiating diodes (LED) are operated alternately in synchronized manner at an appropriate frequency, whereby signals produced at various wavelengths are distinguishable from each other. There is nothing to exclude the use of even several wavelengths as long as, for example, the present optical fiber is capable of transmitting the same and also other optical components operate in a manner compatible therewith. It is also possible to employ other types of radiation sources, such as thermic emitters or lasers. It is also possible to employ two wide-band radiation sources and two detectors having sensitivities which are adapted, e.g. by means of filters transmissive to narrow wavelength bands, to comply with desired wavelengths. In terms of this invention, neither the wavelength of applied radiation nor the width of a wavelength band nor the number of radiation sources and detectors nor the type of radiation sources and detectors are essential features. In addition to a fingertip, the pulsoximeter sensor can be attached for example to the ear, the palm of a hand, or a toe. In that case, the sensor has a different appearance but the diffusively reflective surfaces of this invention function exactly the same way regardless of a measured target. Therefore, it is primarily a finger sensor that will be studied hereinbelow.

A finger sensor 100 as shown in fig. 1 is depicted e.g. in fig. 2 in a lengthwise section. The sensor 100 has its top section 1 and bottom section 3 hinged at 5 in such a manner that both sections of the sensor are capable of opening and closing around a finger 6. Generally, the sensor remains stationary by means of a spring force and a friction developed by pads 7 and 8. Fiberoptic cables 2 and 4, having optical diameters typically in the order of 1-3 mm, are connected to the top and bottom sensor sections 1 and 3 by means of a conventional ferrule 9 and 10 for holding individual fibers in a single bundle and by means of a dewaterer 11 and 12 for providing a durable assembly. The ferrules 9 and 10, like generally all other components in the sensor, are made of materials other than metal if the intension is to employ the sensor in an electromagnetic field. In order to provide a clinically useful sensor, the fiberoptic radiation conductors 2 and 4 arrive in the sensor 100 more or less in the direction of a finger and in general terms the fiberoptic cables arrive in the sensor principally in the direction parallel to the external surface of a target to be measured, in this case an external finger surface 50. Thus, for example in a finger sensor, the optical fibers may arrive in the sensor from the direction of the palm or from the direction of the fingertip or in a direction crosswise to the length of the finger. In a sensor connectable to the earlobe, the optical fibers arrive typically in the direction of the earlobe, and in a sensor to be fitted inside the ear, in the direction of the external auditory canal.

The use of fiberoptic radiation conductors enables all metallic and electric components to be placed remotely from the actual sensor 100, such as in connection with the actual measuring monitor or in some converter between sensor and monitor. The distance is selected to be sufficient for any given application, such that the pulsoximometer sensor does not cause trouble or be troubled itself. When using a diffusively reflective surface of the invention, the optical radiation conducting fiber may comprise a glass fiber which is well transmissive even to quite long-wave infrared radiation since, in a solution of the invention, the fiber need not be bent for bringing the radiation to a desired angle, i.e. generally to an orthogonal direction, relative to the external surface 50 of the target 6.

The light, arriving from a radiation source 38 along a fiber cable 2, exits from the fiber end at a point provided with an inner end wall 13a included in a radiation transfer section of the invention, as a beam of scattering light having a flare angle around the centre axis typically of $\pm 40^\circ$ and with wide-angle fibers $\pm 60^\circ$. A small portion of this light may fall on the external surface 50 of the finger 6 but most of it falls on a diffusively reflective surface 14 of the invention, which is included in a cavity 18 and has a funnel-like shape as shown in the figure and opens towards the target 6. Preferably, the inner end wall 13a of the cavity 18 has a surface area which is in the same order as the cross-sectional area of the bundle of fibers and the surface area of an outer end wall 16 in the direction of at least roughly parallel to the finger surface 50 is larger than that. Thus, the cavity 18 diverges towards a target. The radiation arrives at the transfer section by way of the inner end wall, progresses by way of the diffusively reflective surface 14 and penetrates into a target to be measured through the outer end wall. Thus, depending on the fiber 2, the inner end wall 13a may have a diameter of e.g. 1-3 mm and a preferred diameter for the outer end wall 16 is for example about 7 mm, which enables the scattering of light over a larger surface area and the sensitivity to a motion-related artefact remains insignificant with no light escaping from source to detector without passing through a target. Also, a large surface area complies better with the pulsoximometer's calibrating curve used for determining the relationship with the oxygen content of blood as the local inhomogeneities of a target, such as bone-induced shadings or individual venous blood vessels, are not able to have as strong an effect on the measuring result as would be the case with a smaller outer-end-wall surface area. In terms of operation, the surface areas of the apertures may have any given ratio but, in practice, it is thus preferred that the aperture which opens towards a target to be measured be larger. In a typical case, the outer end wall has a surface area which is at least double with respect to that of the inner end wall but it can be even considerably larger, e.g. tenfold.

The exact configuration of the diffusively reflective surface 14 is not critical, either. It can be a slanting cone

15b, as in fig. 2, but some other configuration, such as an arched-surface funnel 15c shown in fig. 3, functions equally well. In the embodiment of figs. 5A-5B, the funnel can be an oblique wedge, whereby a diffusively reflective surface 30 is flat or a slanting cone or cylinder, said diffusively reflective surface 30 being concave towards the inside of a cavity 18. In the former case, the image-plane facing cross-section of the cavity is a rectangle and in the latter case it is a circle or an ellipse. If it is flat, the diffusively reflective surface should be preferably arranged at least in a roughly orthogonal attitude towards the bisector of an angle formed by the inner-end-wall normal and the outer-end-wall normal together, as shown e.g. in figs. 5A-5B. As for the arched funnel 15c, on the other hand, it is appropriate to arrange the inner end wall and the outer end wall in such a manner that the normals thereof intersect the diffusively reflective surface or a surface section or an extension thereof, in other words the normals of the end walls must be directed towards the diffusively reflective surface. The aperture of the outer end wall 16 of a funnel is preferably covered e.g. with a window for preventing dirt from finding its way into the cavity 18 and further onto the end surface of a bundle of fibers or onto the diffusively reflective surface. The window may be constructed e.g. of silicone or some other appropriate material. Another option is to fill the entire cavity 18 with a light transmitting material, for example with similar bright silicone. This is not harmful for the proper function of a diffusively reflective surface. It is obvious that the inner and outer end wall can be sealed with windows made of an appropriate material and the cavity 18, 41 filled with an appropriate gas or liquid.

Having passed through the finger, the light is completely scattered and at the point of measuring each dot of the finger operates as a Lambert source. Light is arriving from quite a wide range and the effective collection thereof on the endwall surface of the fiber or bundle of fibers 4 is not easy no matter which of the actually occurring diameter and flare angle is used for the fiber or bundle of fibers. Nevertheless, the fiber 4 should be capable of carrying to a detector 37 as much as possible of the radiation coming from a target to be measured. A diffusively reflective surface 17 similar to the surface 14 contributes even on the radiation collection side to an increased collecting efficiency, as pointed out hereinafter. In terms of its dimensions, it can be similar to the funnel surface 14 but it may also have some other configuration, particularly if the fiber bundles 2 and 4 are different from each other. Thus, the collection of radiation from a target 6 is effected by means of a similar type of cavity 18 as the supply of radiation to the target 6, said cavity 18 thus including an inner end wall 19a, by way of which the collected radiation transfers to the fiber 4, as well as an outer end wall 26, by way of which the radiation enters inside the cavity to be subsequently reflected from the diffusively reflective surface 17. The design can be totally analogous to the above-described

radiation supplying cavity. Thus, the outer end wall 26 has a surface area which preferably exceeds that of the inner end wall 19a, typically the outer end wall has surface area which is at least double with respect to that of the inner end wall, but it may be even considerably larger, e.g. tenfold. In view of the actual operation, the apertures may have surface areas whose ratio to each other can be anything, as already described above. Also in this case, the end walls must have the normals thereof directed towards the diffusively reflective surface or an extension thereof, as explained above. Even in this case, the aperture in the outer end wall 26 of the funnel can be covered with bright silicone or some other compatible material or the entire cavity 18 filled with this material without disturbing operation of the diffusively reflective surface.

In the above-described embodiments of figs. 2 and 3, in the embodiment of figs. 5A and 5B, as well as partially in the embodiments of figs. 6 and 8, the cavity 18 is provided with inner end walls 13a, 19a, 13b, 19b and 32 which form an angle K relative to the outer end wall 16, 26 and 35 of the cavity, said angle being within the range of 30°-100°, generally at least 45°, preferably within the range of 60°-95° and typically about 90°. This angle is explained further in fig. 12. In figs. 2-3, 5A-5B, 6 and 8, the angle K is essentially a right angle, but if so required by a particular application, it can be somewhat more than 90°, as pointed out above. This described angle configuration enables the passage of the fiberoptic radiation conductor 2, 4 to a sensor e.g. in the direction of the external surface 50 of a target or in some other appropriate direction without having to bend the optical fiber. Naturally, the inner end walls 13b and 19b can be perfectly or approximately parallel to the given respective outer end wall 16 and 26, as depicted in figs. 7 and 9 and to be subsequently described in more detail. In any event, between the inner end wall and the outer end wall is fitted a diffusively reflective surface of the invention. The outer end wall is set against the external surface of a target to be measured, whereby a slight gap is often left therebetween no matter if the question is about the side supplying radiation to a target or the side collecting radiation from a target. The inner end wall refers to a point of contact with an optical fiber or some other radiation conducting element or with radiation sources or a detector or a like. In theory, it is not absolutely necessary that a jacket of the cavity 18 be provided between the end walls to surround the end walls as well as the diffusively reflective surface although, in practice, the cavity and its jacket are normally necessary for avoiding external mechanical and physical and chemical drawbacks.

The qualities of a diffusively reflective surface are depicted in fig. 4. A ray of light 20 falls on various types of diffusively reflective surfaces 21, 22 and 23. The roughness of a surface and the optical characteristics of a material determine how the ray is reflected. It is of course desirable that the surface does not absorb the

applied radiation and that the material is not so thin that the light is able to escape therethrough. The light may reflect directly from the surface or it may travel deeper in a diffusively reflective material prior to reflecting back.

5 The surface 21 is a so-called Lambert surface which completely scatters the light 20 fallen thereon. In that case, the roughness of a surface material or the size of the structural elements of a material is lesser than or in the same order as the light's wavelength. The light scatters in every direction such that the reflected radiation has an intensity distribution which follows a dotted line 10 24 (the distribution is represented by a sphere which is tangential with the reflective surface, the 5 intensity vectors starting from tangential points and terminating at the ball surface). Such a surface appears equally bright 15 from every direction and is theoretically the best possible scattering surface, i.e. a diffusively reflective surface. Such a surface is difficult to manufacture, but for example Labsphere, Inc. is marketing a material called Spectralon, having characteristics which are very close 20 to those of the surface 21. The same type of material is also available as a coating. The materials and coatings have a reflectance of about 99 %, hence the absorption and transmission are insignificant. The surface 22 depicts a case in which a scattering section 25 is significant 25 but in which also a mirror reflection 26 of the surface is visible. It is useful also in a sensor of the invention although the efficiency is slightly poorer than what is achieved by the surface 21. Several scattering materials belong in this category. For example, the commercially 30 available silicone polymers, which are readily mouldable to a proper shape, may remain slightly shining over the surface thereof and, thus, some mirror reflection is inevitable. However, the mirror reflection of a surface has an intensity whose proportion is generally modest 35 with respect to the diffusively reflected intensity, since the mirror reflection depends on the index of refraction of a material, which on silicone polymers is relatively low, and since the material is non-metallic. The surface 40 23 is rougher than the surfaces 21 and 22, as evidenced by the fact that an intensity distribution 27 is an ellipse or ellipsoid parallel to a mirror reflection 28. However, the scattering or ray-diffusing effect continues to be dominant. The ray-diffusing results from the fact that 45 light reflects from various roughness patterns of a surface in directions other than the one in which the radiation would reflect from a common mirror surface and, hence, the intensity patterns resembles a scattering pattern. Generally, the practical diffusively reflective surface is a combination of all surfaces shown in fig. 4. Although non-metallic materials are in most cases used 50 in diffusively reflective surfaces, it is not inconceivable, in principle, to employ a suitably surface-treated metal as well, if the particular application allows the use of metal in the sensor. A metal treated to be diffusively reflective may be the only solution when it is necessary to use 55 extremely long wavelengths. However, this is not the case in a normal pulseoximeter sensor and, thus, the use

of non-metallic materials is plausible.

Figs. 5A and 5B illustrate how the diffusively reflective surface operates as a light collecting system and why its use is preferred. In fig. 5A, a ray 29 arrives from a radial direction preferable in terms of mirror reflection from a diffusively reflective surface 30, which can be any of the surfaces 21, 22 or 23 depicted in fig. 4. Even after the mirror reflection, the ray would be likely to fall on the endwall surface of a bundle of fibers 31, which is in alignment with an inner end wall 32, since the bundle of optical fibers 31 accepts all angles 36 smaller than the flare angle of the fiber. In fig. 5B, on the other hand, a ray 33 arrives from such a direction that the mirror reflection would take it completely out of the system as a ray 34. This is not preferred, although it is possible to presume that a portion of the ray, having reflected again from the surface of a target, arrives in the funnel, be it in a decisively weakened condition. Presuming subsequently that the surface 30 is totally diffusively reflective, i.e. a so-called Lambert surface mentioned above, and performing a comparison between such a diffusively reflective surface of the invention and a bundle of fibers in direct contact with a target. Supposing 5 further that the bundle of fibers 31 has a diameter of 2 mm in keeping with the diameter of the inner end wall 32 and that an outer end wall 35, i.e. an inlet aperture, included in the cavity 18 and opening towards the target, has a diameter of 7 mm. The operating principle of a diffusively reflective cavity is the same as that of an integrating sphere and, thus, it is possible at a sufficient accuracy to apply computation formulae relating to an integrating sphere. The cavity includes two apertures 32 and 35, as generally found in an integrating sphere. As an exception from the normal integrating sphere it is possible to accept the fact that some radiation advances directly from aperture 35 to aperture 32 without hitting the cavity wall, in other words, the aperture 35 is visible from the aperture 32. This is beneficial in terms of the invention as there will be no reflection losses. It is contemplated, however, that the entire radiation falls at least once on the diffusively reflective surface 30. A portion T2 of the intensity arriving in the aperture 35, which exits from aperture 32, will thus be

$$T2 = f2 * R_w / [1 - R_w * (1 - f1 - f2) - R1 * f1],$$

wherein f1 and f2 represent the ratio of the surface areas of aperture 32 and 35 to a surface area A of the entire cavity, R_w is a reflection factor for the diffusively reflective surface and R1 is a reflection factor for the outer end wall 35 or, more precisely, for the external surface 50 of the target 6. The value of the surface area A is not highly critical although a small value seems to be beneficial in this case. The value given in this example is 100 mm². The reflection factor for the cavity was measured with the use of white silicone as R_w = 0,93 and the reflection factor for a target, i.e. the human skin, was estimated,

as measured with red light, to be R1 = 0,6. Thus, the reflectivity of the target 6 is generally also contributing to the signal. Using these values, the resulting transmission will be T2 = 0,13. A surface of the target 6 defined by the aperture 35 contains diffusively transmitting Lambert sources $(7/2)^2 = 12,25$ times more than what could be directly accommodated by the aperture 32, i.e. a higher number of sources in terms of the ratios between surface areas of the apertures. Thus, the gain of collection would be $0,13 * 12,25 = 1,59$ i.e. the result will be a signal more than one and a half times stronger than what could be produced by collecting directly with the fiber end. The performed measurements have clearly supported this theory, although the augmentation of a signal has been slightly lesser than calculated, probably due to an imperfect contact between target 6 and the outer end wall of cavity 18, a lower-than-expected reflection factor for the target, and inhomogeneous lighting of the target.

Thus, with a larger surface area of the outer end wall 16, 26 and 35 it is possible to collect more light on the inner end wall 13a, 13b, 13c, 19a, 19b and 32 by using the diffusively reflective surface 14, 17, 21-23, 30 between the target 6 and a radiation source or a detector, e.g. in the cavity 18, 41, and at the same time the direction of radiation coming from the target can be deflected as desired or, in this case, to comply with the direction of the optical fiber 4, 31. Other benefits from using a larger surface area include a reduced sensitivity to a motion-related artefact, be it a directly external disturbance or an internal disturbance resulting for example from volumetric changes in venous blood.

The foregoing has described but a few examples of how a diffusively reflective surface or material can be utilized in a pulsoximometer sensor operating on fiber optics. It is obvious that there are other conceivable types of solutions based on the same principle of diffusive reflection. The optical fiber is not absolutely necessary for proper functioning of the inventive principle, although a fiberoptic pulsoximometer sensor is a preferred application. Even a conventional sensor, wherein light sources 38 and a detector 37 are included in a very sensor 100 closer to a target 6 to be measured, can be improved by using diffusively reflective surfaces in accordance with the invention. One such solution is depicted in fig. 6. In this solution, a detector 37 is located close to a target 6 to be measured, as in traditional sensor designs. On the other hand, the light sources 38, normally two diodes (LED) emitting at different wavelengths, are, according to the invention, mounted on an inner end wall 13b included in a diffusively reflective cavity 15c. In principle, the number of radiation sources 38 can be more than two, if so required by a particular application, or a more-than-normal amount of power can be supplied thereto. A higher light supply improves the signal-to-noise ratio, which otherwise may be too poor in certain operating conditions. The increased power consumption and the accompanying rise in temperature are not in this assem-

bly focused on a target 6 to be measured but can be effectively guided to a top unit 1. This serves to eliminate possible heat-inflicted damages in the target 6 to be measured. In addition, the effect on a measuring result due to the position of various light sources will be equalized. Electric supply signals from both the detector 37 and the light sources 38 are carried along an electric cable 39 to a control monitor.

Fig. 7 illustrates another corresponding solution, wherein a diffusively reflective surface 14 included in a cavity 41 is not laterally curving but, instead, a direct cone 15a facing straight towards a target 6 and having its inner end wall 13b, along with radiation sources 38 included therein, at such a distance from the target 6 to be measured that eventual generated heat can be delivered away from the target to a frame 1. The cavity-forming direct cone 15a has a function otherwise similar to slanting or arching funnels 15b and 15c except that the proportion of direct light from sources to target is higher. If the funnels 15a-c reflect diffusively at a high efficiency, the signal should indicate no difference between the different types of cavities 18 and 41.

The detector may also utilize a diffusively reflective cavity for example for eliminating the effect of a motion-related artefact, as in the solution shown in fig. 8. In this solutions, light sources 38 are located close to the surface of a target 6 but could just as well be located further away from a target according to fig. 6 or 7. A detector 37 is further away from the surface of the target 6 at an inner end 19b included in a cavity, which is provided with a diffusively reflective surface and is, in this case, an arched funnel 15c. Exactly the same way as in the solution of fig. 7, the detector 37 may also be directed straight towards the target 6, as shown in fig. 9, by using an appropriately shaped direct cone 15a as a cavity 41. In the solutions shown in figs. 8 and 9, the detector 37 can be used for indicating light from a larger surface section of the target 6 and, as pointed out above, for producing even more signal than could be achieved if the detector were in a conventional manner close to the target surface.

All the above pulsoximeter sensors have been ones that are based on a transmission measured straight through a target. Thus, a direction S of the principal radiation from a radiation source 38 and/or a respective diffusively reflective surface and a principal sensitivity direction H indicated by way of a detector and/or a respective diffusively reflective surface are substantially opposite to each other, i.e. form a relative angle of 180° or form an obtuse angle V1, as illustrated in fig. 13. This produces a light 54 passing directly through a target for obtaining a measuring signal.

There is nothing to stop applying the inventive principle also to a pulsoximeter sensor 101 operating on a reflection principle. In this type of preferred sensor configuration, as shown e.g. in fig. 10, it is important that light sources 38 and a detector 37 be located side by side in the direction of an external target surface 50 at

such a distance from each other that a light 44 is forced to progress an arterial-blood containing tissue of a target 6 to be measured prior to reflecting back instead of traveling along the surface layer of a tissue. A cavity 41, including a diffusively reflective surface and having its inner end wall 13c provided with a detector 37, is also in this type of sensor capable of collecting more light from deep in the tissue than what could be achieved if the detector were in a direct contact with the target 6.

The sensor assembly is generally provided with just one body element 42 and a pad 43, sometimes combined, on which light sources and a detector are mounted and from which a signal is delivered for further processing by way of a cable 39. The sensor 101 can be fastened to a target by means of a tape, a rubber band or by other respective means. Although the described sensor is electric, there is nothing that would prevent the use of optical fibers for this solution as well, as already explained above. The cavity 41, shown in fig. 10 and including a diffusively reflective surface, only measures light over one side of the light sources. The aperture in the cavity 41, opening towards a target 6, need not be circular as some other appropriate shape is equally suitable. Fig. 11 depicts a configuration for radiation sources 38 effectively collecting radiation reflected from the entire environment. In this solution, the light sources 38 are located in the middle of an outer end 26 included in the cavity 41 provided with a diffusively reflective surface and at least close to the plane of said outer end, in other words, the light sources and detectors are fitted within each other. Thus, the detector 37, which is located in alignment with an inner end 13c of the cavity, receives reflected light 44 from as large as possible a target surface area. The light sources 38 are optically insulated from the cavity 41 with a light blocking surface 45, which surrounds the light sources in the direction of the outer end, whereby the light being collected in the cavity has inevitably been forced to travel deep in the tissue. In this case, the cavity 41 is preferably filled with a bright material, such as silicone. In the embodiments of figs. 10 and 11, a direction S of the principal radiation from a radiation source 38 and/or a respective diffusively reflective surface and a principal sensitivity direction H indicated by way of a detector and/or a respective diffusively reflective surface are substantially co-directional, i.e. form a relative angle of 0° or form an acute angle V2, as illustrated in fig. 14. This produces a light 44 reflecting from the tissue of a target for obtaining a measuring signal.

The disclosed embodiments are but examples of how a diffusively reflective cavity can be used in a pulsoximeter sensor. It is self-evident that other representative solutions exist as well. For example, it is conceivable to use just a single light source and respectively two or more detectors, although the above-described configurations are most common.

Thus, it is not a requirement in this invention that both the radiation sources 38 and the detectors 37 be

provided with diffusively reflective surfaces but either one is nevertheless equipped with a diffusively reflective surface fitted between the external target surface 50 and a radiation source or a detector. Conditions permitting, the sensor may only be provided with one above-mentioned funnel, either on the inlet or outlet side, which provides a diffusively reflective surface. A second funnel is then replaced by another type of construction, such as electronic components or a different fiberoptic system. In principle, the funnel may be nearly any shape at all. Fig. 2 illustrates a slanting cone 15b, figs. 3, 6 and 8 depict an arched cone 15c, and figs. 7-8 and 10-11 show a direct cone 15a. The slanting wedge illustrated in conjunction with figs. 5A-5B is a special case among these funnels. The funnel, which forms a cavity 18, 41, need not be diffusively reflective over its entire inner surface, although it is most preferred. If necessary, it is possible to employ such a diffusively reflective surface, towards which the sensitive surface of detectors and/or respectively the emitting surface of radiation sources and/or the end of an optical fiber are directed. The rest of the interior of an eventual cavity 18, 41 can be made of another type of material, e.g. some more or less radiation-absorbing material. For example, if in the case of figs. 5A-5B, the diffusively reflective surface 30 is flat and orthogonal to the image plane, the ends not shown in the figures and extending parallel to the image plane can be non-diffusively reflective. However, it is preferred that as large a portion as possible of a radiation transfer section fitted between the inner end and the outer end be designed as diffusively reflective according to the invention.

Claims

1. A pulsoximeter for measuring the degree of oxygen saturation in a patient's blood non-invasively, a sensor (100, 101) comprising:
 - a radiation source or radiation sources (38) for emitting measuring radiation with at least two wavelengths to a portion of the body of a patient;
 - detectors or respectively a detector (37) for receiving measuring radiation transmitted through said body portion of a patient and for transforming the same to electrical form;
 - at least one radiation transfer section which is located between either the radiation sources or respectively the detectors and an external surface (50) of said body portion (6),

characterized in that the radiation transfer section includes measuring-radiation transmitting ends (13a,b,c; 19a,b; 32 and 16; 26; 35), whereof the outer end (16; 26; 35) facing the external body surface (50) has a surface area which is larger than the sur-

2. A pulsoximeter sensor as set forth in claim 1, **characterized** in that said diffusively reflective surface (14, 17; 21-23; 30) is at least a portion of the jacket of a cavity (18, 41), which is in the shape of a direct (15a), slanting (15b) or arched (15c) funnel, extending from inner end to outer end and having an internal surface whose cross-sectional shape is circular, elliptical or polygonal, that the inner end (13a,b,c; 19a,b; 32) and the outer end (16; 26; 35) are either parallel to each other or form an angle (K) relative to each other and that the outer end has surface area which is at least double and typically about ten-fold with respect to the surface area of the inner end.
3. A pulsoximeter sensor as set forth in claim 2, **characterized** in that said cavity (18, 41) has a jacket which is at least for the most part, preferably overall diffusively reflective; or alternatively said funnel is a symmetric or asymmetric wedge, wherein a first wedge surface (30) is more or less orthogonal to the bisector of an angle formed by the normals of an inner and outer end (32 and 34) with each other and that at least this first wedge surface (30) is diffusively reflective.
4. A pulsoximeter sensor as set forth in claim 2, **characterized** in that, when said funnel is an arched cone (15c), the inner and outer end are located such that the normals thereof intersect the diffusively reflective surface (14, 17) or an extension thereof on the side of the cone with a maximum radius of curvature.
5. A pulsoximeter sensor as set forth in claim 1 or 2, **characterized** in that the inner end and the outer end form a relative angle (K), which is at least 45°, preferably at least 60° and typically about 90°.
6. A pulsoximeter for measuring the degree of oxygen saturation in a patient's blood non-invasively, a sensor (100, 101) comprising:
 - a radiation source or radiation sources (38) for emitting measuring radiation with at least two wavelengths to a portion of the body of a patient;
 - detectors or respectively a detector (37) for receiving measuring radiation transmitted through said body portion of a patient and for transforming the same to electrical form;
 - at least one radiation transfer section which is located between either the radiation sources or respectively the detectors and an external sur-

face (50) of said body portion (6),

- characterized** in that the radiation transfer section includes measuring-radiation transmitting ends (13a,b,c; 19a,b; 32 and 16; 26; 35), whereof the outer end (16; 26; 35) facing the external body surface forms relative to the inner end facing any given radiation sources or respectively detectors an angle (K), which is between 30°-100°, preferably between 60°-95° and typically about 90°, as well as a measuring-radiation diffusively reflecting surface (14, 17; 21-23; 30) between these ends.
7. A pulsoximeter sensor as set forth in claim 6, **characterized** in that said diffusively reflective surface (14, 17; 21-23; 30) is at least a portion of the jacket of a cavity (18, 41), which is in the shape of a slanting funnel (15b) or an arched funnel (15c) extending from inner end to outer end and being for the most part a diffusively reflective or asymmetric wedge, wherein a first wedge surface is more or less orthogonal to the bisector of an angle formed by the normals of the inner and outer end relative to each other and that at least this first wedge surface (30) is diffusively reflective.
8. A pulsoximeter sensor as set forth in claim 1 or 6, **characterized** in that between said inner end (13a, b,c; 19a,b; 32) and the radiation sources (38) and respectively the detectors (37) is fitted a fiberoptic radiation conductor (2, 4), which consists of one or a plurality of optical fibers, and that the fiberoptic radiation conductor consists of glass fiber or some other long-wave infrared radiation transmitting single or a plurality of fibers.
9. A pulsoximeter sensor as set forth in claim 1 or 6, **characterized** in that the detector or detectors (38) and/or the radiation source or radiation sources (37) are located in line with said inner end (13a,b,c; 19a, b; 32) and that the radiation sensitive surfaces or respectively the emitting surfaces thereof or, alternatively, the ends of optical fibers are directed towards the diffusively reflective surface (14, 17; 21-23; 30).
10. A pulsoximeter sensor as set forth in claim 1 or 6, **characterized** in that said diffusively reflective surfaces (14, 17; 21-23; 30) scatter a bulk (24; 25, 26; 27, 28) of arriving radiation intensity (20) in directions other than the mirror-reflection departing angle corresponding to the angle of incidence of arriving radiation and preferably the diffusively reflective surfaces are as close as possible to a Lambert surface in terms of the qualities thereof.
11. A pulsoximeter sensor as set forth in claim 1 or 6, **characterized** in that said diffusively reflective sur-

face (14, 17; 21-23; 30) consists of a solid material, provided with a cavity which is coated on the inside with a diffusively reflective surface material, or the diffusively reflective surface (14, 17; 21-23; 30) consists of a partially radiation-transmitting and simultaneously diffusively reflective material, and that a gap between the inner and outer ends (13a,b,c; 19a,b; 32 and 16; 26; 35) is up the diffusively reflective surface filled with a measuring-radiation transmitting material, such as an appropriate gas or a bright silicone compound.

12. A pulsoximeter sensor as set forth in claim 1 or 6, **characterized** in that in this sensor:
- (a) the detector (37) with its associated diffusively reflective surfaces (17; 21-23; 30) and the radiation sources (38); or
 - (b) the detector (37) and the radiation source (38) with its associated diffusively reflective surfaces (14; 21-23); or
 - (c) the detector (37) with its associated diffusively reflective surfaces (17; 21-23; 30) and the radiation source (38) with its associated diffusively reflective surfaces (14; 21-23) are located either
 - opposite to and essentially in register with each other, whereby a sensitivity direction (H) and a radiation direction (S) extend against each other or form together an obtuse angle (V1) creating a direct transmission (54), or
 - side by side, whereby the sensitivity direction (H) and the radiation direction (S) extend in the same direction or form together an acute angle (V2) creating a reflection (44).
13. Use of a pulsoximeter sensor, comprising: a radiation source or radiation sources (38) which emit measuring radiation with at least two wavelengths to a portion of the body of a patient; detectors or respectively a detector (37) for receiving the measuring radiation having passed through said portion of a patient's body and for converting the same to electric form; at least one radiation conducting section, which is located between either the radiation source or respectively the detectors and the external surface (50) of said body portion (6), for measuring the degree of oxygen saturation in a patient's blood non-invasively, **characterized** in that said section is a cavity (18, 41), having a jacket which is at least over a substantial section thereof measuring-radiation diffusively reflecting (14, 17; 21-23; 30), that, regarding the measuring-radiation transmitting ends of the cavity, the outer end (16; 26; 35) facing the external body surface has a surface area

which is larger than the surface area of the inner end (13a,b,c; 19a,b; 32) facing the radiation source or respectively the detectors, and that his outer end is set against the external body surface (50) of a patient for measuring.

5

14. Use of a pulsoximeter as set forth in claim 13, **characterized** in that the measurement occurs on the basis of that radiation which directly passes (54) through the blood-containing portion (6) of a patient's body, whereby the detector with its associated cavity and the radiation source or the detector and radiation source with its associated cavity are located opposite to each other and substantially in register with each other, the sensitivity direction (H) and the radiation direction (S) extending against each other or forming together an obtuse angle (v_1).

10

15

15. Use of a pulsoximeter as set forth in claim 13, **characterized** in that the measurement occurs on the basis of that radiation which reflects (44) from inside the blood-containing portion (6) of a patient's body, whereby the detector with its associated cavity and the radiation source or the detector and radiation source with its associated cavity are located side by side or within each other, the sensitivity direction (H) and the radiation direction (S) extending in the same direction or forming together an acute angle (v_2).

20

25

16. Use of a pulsoximeter as set forth in claim 13, **characterized** in that the radiation source or radiation sources (38) are located by means of a fiberoptic radiation conductor (2) remotely from the sensor (100) and/or the detector or detectors (37) are located by means of a fiberoptic radiation conductor (4) remotely from the sensor (100).

30

35

40

45

50

55

11

EP 0 781 527 A1

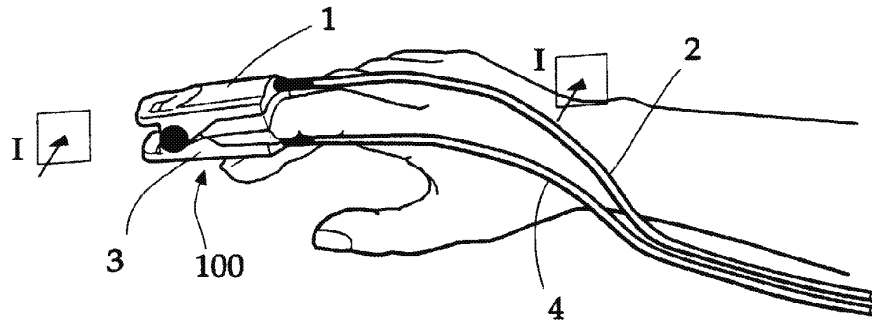

Fig. 1

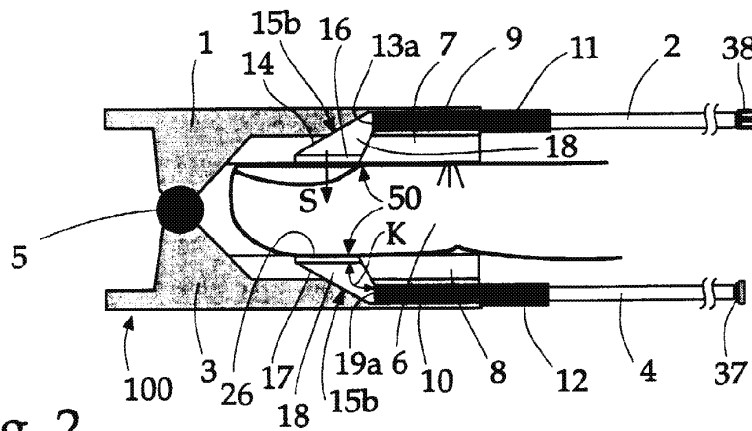

Fig. 2

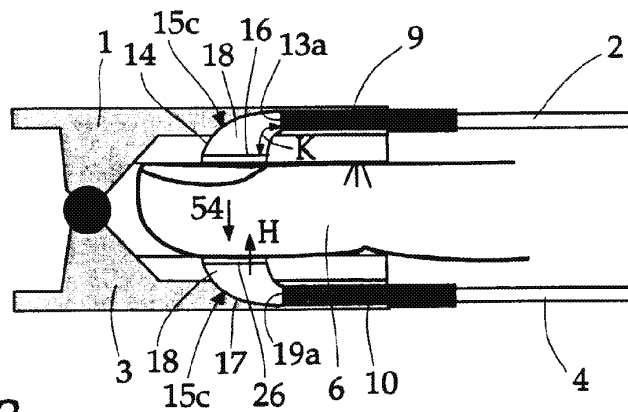

Fig. 3

EP 0 781 527 A1

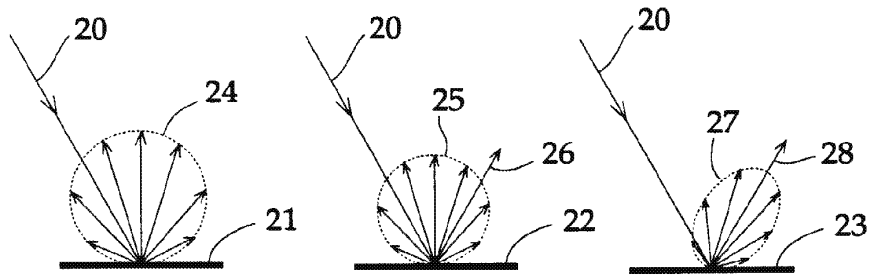

Fig. 4

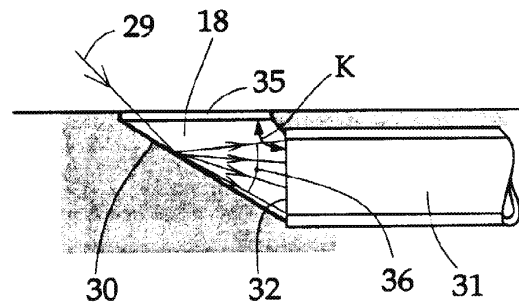

Fig. 5A

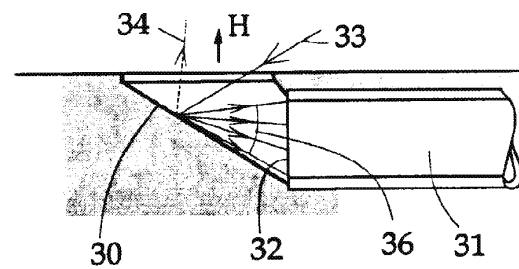

Fig. 5B

EP 0 781 527 A1

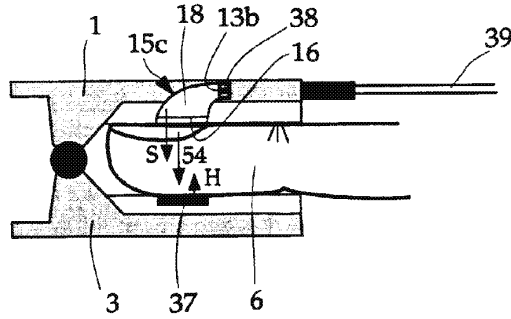

Fig. 6

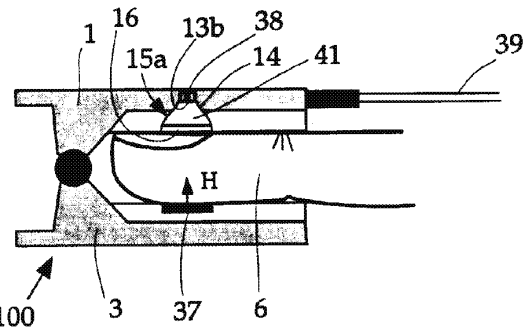

Fig. 7

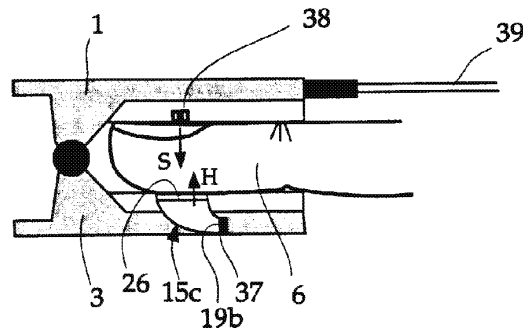

Fig. 8

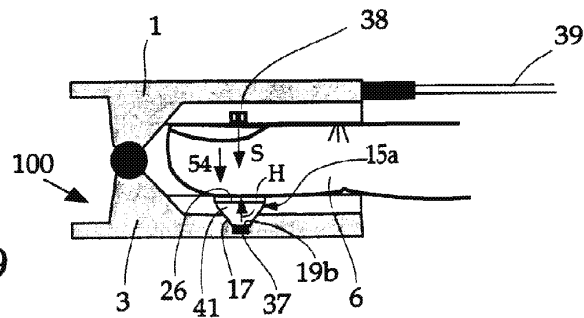

Fig. 9

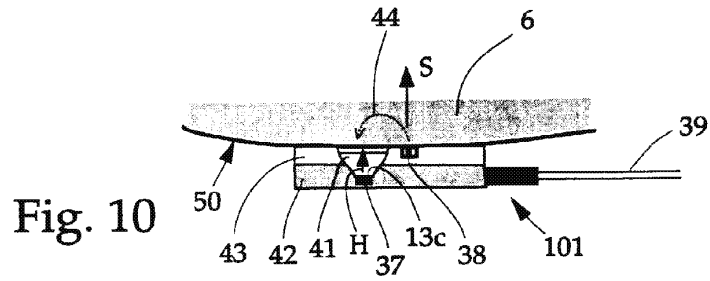

Fig. 10

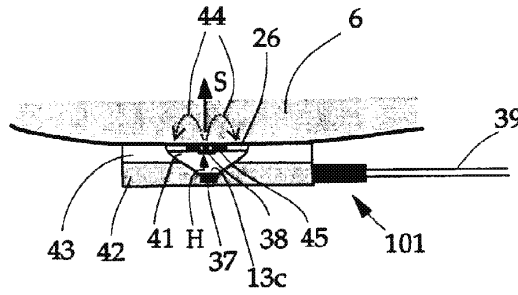

Fig. 11

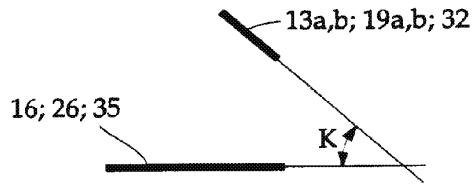

Fig. 12

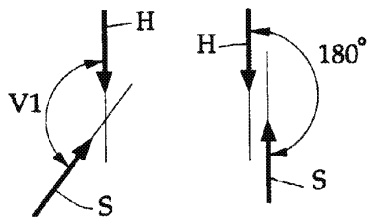

Fig. 13

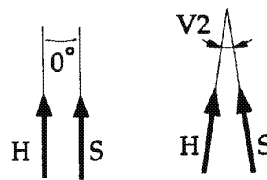

Fig. 14

EP 0 781 527 A1



European Patent Office

EUROPEAN SEARCH REPORT

Application Number
EP 96 66 0092

DOCUMENTS CONSIDERED TO BE RELEVANT			
Category	Citation of document with indication, where appropriate, of relevant passages	Relevant to claim	CLASSIFICATION OF THE APPLICATION (Int.Cl.6)
Y	US 3 123 066 A (C.H. BRUMLEY)	1-3,5,6	A61B5/00
Y	* column 2, line 9 - column 3, line 12 *	8,9, 12-16	G02B6/36
A	* column 3, line 35 - line 59 * ---	10,11	
Y	DE 25 17 129 B (SIEMENS A.G.)	1-3,5,6	
Y	* column 2, line 24 - line 55 *	8,9, 12-16	
A	* column 3, line 9 - column 4, line 16 * -----	4,5	
			TECHNICAL FIELDS SEARCHED (Int.Cl.6)
			A61B G02B
The present search report has been drawn up for all claims			
Place of search THE HAGUE		Date of completion of the search 27 March 1997	Examiner Rieb, K.D.
CATEGORY OF CITED DOCUMENTS		T : theory or principle underlying the invention E : earlier patent document, but published on, or after the filing date D : document cited in the application L : document cited for other reasons & : member of the same patent family, corresponding document	
X : particularly relevant if taken alone Y : particularly relevant if combined with another document of the same category A : technological background O : non-written disclosure P : intermediate document			

EPO FORM 1501 (01.02.1998)



(11) **EP 2 277 440 A1**

(12) **EUROPEAN PATENT APPLICATION**
published in accordance with Art. 153(4) EPC

(43) Date of publication:
26.01.2011 Bulletin 2011/04

(51) Int Cl.:
A61B 5/026 ^(2006.01) **A61B 5/0245** ^(2006.01)
A61B 5/0285 ^(2006.01)

(21) Application number: **08752576.2**

(86) International application number:
PCT/JP2008/058693

(22) Date of filing: **12.05.2008**

(87) International publication number:
WO 2009/139028 (19.11.2009 Gazette 2009/47)

(84) Designated Contracting States:
AT BE BG CH CY CZ DE DK EE ES FI FR GB GR HR HU IE IS IT LI LT LU LV MC MT NL NO PL PT RO SE SI SK TR
Designated Extension States:
AL BA MK RS

(72) Inventors:
• **ONOE, Atsushi**
Tsurugashima-shi
Saitama 350-2288 (JP)
• **KIMURA, Yoshinori**
Tsurugashima-shi
Saitama 350-2288 (JP)

(71) Applicant: **Pioneer Corporation**
Kanagawa 212-0031 (JP)

(74) Representative: **Viering, Jentschura & Partner**
Grillparzerstrasse 14
81675 München (DE)

(54) **SELF-LUMINOUS SENSOR DEVICE**

(57) A light-emitting sensor device is provided with: a substrate (110); an irradiating part (120), disposed on the substrate, for applying light to a specimen; a light receiving part (150), disposed on the substrate, for detecting light from the specimen caused by the applied light; a light scattering part, disposed at least one of be-

tween the irradiating part and the specimen and between the specimen and the light receiving part, for scattering at least one of light emitted from the irradiating part and the light from the specimen. By this, it is possible to stably detect a predetermined type of information, such as a blood flow velocity, on the specimen.

[FIG. 8]

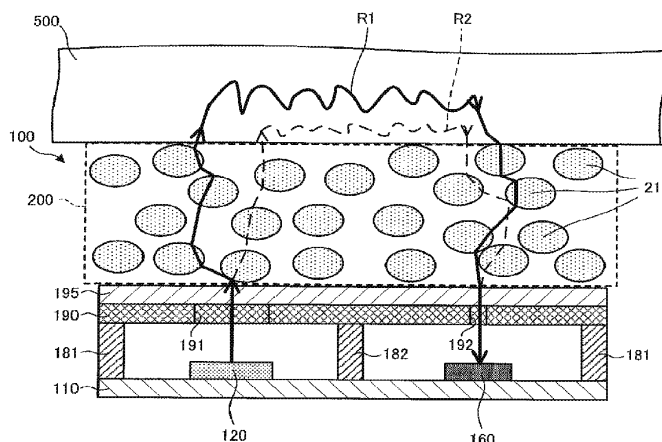

EP 2 277 440 A1

Printed by Jouve, 75001 PARIS (FR)

APL_MAS_ITC_00557173

Description

Technical Field

[0001] The present invention relates to a light-emitting sensor device capable of measuring a blood flow velocity or the like.

Background Art

[0002] As this type of light-emitting sensor device, there is a device for applying light such as laser light to a living body and for calculating the blood flow velocity of the living body from a change in wavelength by Doppler shift in its reflection or scattering (e.g. refer to patent documents 1 to 3).

[0003] On the other hand, for example, in a patent document 4, there is suggested a technology in which measurement accuracy is increased by providing a light scatterer on light incoming side and outgoing side with respect to body tissue on a device for measuring the concentration of a light absorbing material in the body tissue by using a pulse photometry technology.

[0004]

- Patent document 1: Japanese Patent Application Laid Open No. 2004-357784
- Patent document 2: Japanese Patent Application Laid Open No. 2004-229920
- Patent document 3: Japanese Patent Application Laid Open No. 2006-130208
- Patent document 4: Japanese Patent Application Laid Open No. 2001-198111

Disclosure of Invention

Subject to be Solved by the Invention

[0005] However, according to the aforementioned light-emitting sensor device, there is a technical problem in which the detection value, such as a blood flow velocity, of the living body likely varies due to the subtle movement of the living body and a change in pressure on the living body in detection. Thus, if the aforementioned light-emitting sensor device is used as a medical device, there is a possibility that the accuracy of the detection value, such as a blood flow velocity, of the living body is not sufficiently reliable.

[0006] In view of the aforementioned problems, it is therefore an object of the present invention to provide a light-emitting sensor device which reduces a change in the detection value due to a shift in relative position relation between the light-emitting sensor device and a specimen and which can stably detect a predetermined type of information, such as a blood flow velocity, on the specimen.

Means for Solving the Subject

[0007] The above object of the present invention can be achieved by a light-emitting sensor device provided with: a substrate; an irradiating part, disposed on the substrate, for applying light to a specimen; a light receiving part, disposed on the substrate, for detecting light from the specimen caused by the applied light; a light scattering part, disposed at least one of between the irradiating part and the specimen and between the specimen and the light receiving part, for scattering at least one of light emitted from the irradiating part and the light from the specimen.

[0008] According to the light-emitting sensor device of the present invention, in its detection, the light such as laser light is applied to the specimen, which is one portion of a living body, by the irradiating part including e.g. a semiconductor laser. The light from the specimen caused by the light applied to the specimen in this manner is detected by the light receiving part including e.g. a light receiving element. Here, the "light from the specimen caused by the light applied to the specimen" means light caused by the light applied to the specimen, such as lights reflected, scattered, diffracted, refracted, transmitted through, Doppler-shifted in the specimen and interfering light by the above lights. On the basis of the light detected by the light receiving part, it is possible to obtain predetermined information such as a blood flow velocity associated with the specimen.

[0009] In the present invention, in particular, the light scattering part is disposed at least one of between the irradiating part and the specimen and between the specimen and the light receiving part. The light scattering part is made of a fibrous material such as a woven fabric and a nonwoven fabric, and it scatters at least one of the light emitted from the irradiating part and the light from the specimen. For example, if the light scattering part is disposed both between the irradiating part and the specimen and between the specimen and the light receiving part, the light emitted from the irradiating part is scattered by the light scattering part and then applied to the specimen. The light from the specimen caused by the light applied to the specimen is scattered by the light scattering part and then detected by the light receiving part.

[0010] According to the study of the inventors or the like, by that the light scattering part is disposed at least one of between the irradiating part and the specimen and between the specimen and the light receiving part, it is possible to reduce a change in the detection value of the light detected by the light receiving part, which is caused by, for example, a shift in relative position relation between the light receiving part and the specimen, in comparison with a case where the light scattering part is not disposed between the irradiating part and the specimen and between the specimen and the light receiving part. Therefore, on the basis of the light detected by the light receiving part, it is possible to stably detect the predetermined type of information, such as a blood flow velocity,

on the specimen. As a result, it is possible to increase the reliability of the detection value detected by the light-emitting sensor device.

[0011] As explained above, according to the light-emitting sensor device of the present invention, it is provided with the light scattering part disposed at least one of between the irradiating part and the specimen and between the specimen and the light receiving part, so that it is possible to reduce the change in the detection value caused by the shift in relative position relation between the light-emitting sensor device and the specimen. Thus, it is possible to stably detect the predetermined type of information, such as a blood flow velocity, on the specimen.

[0012] In one aspect of the light-emitting sensor device of the present invention, the light scattering part includes a fibrous material.

[0013] According to this aspect, the light scattering part is made of, for example, a woven fabric or a nonwoven fabric. Thus, by virtue of the light scattering part, it is possible to preferably scatter at least one of the light emitted from the irradiating part and the light from the specimen, and it is possible to surely reduce the change in the detection value caused by the shift in relative position relation between the light-emitting sensor device and the specimen. Moreover, if the light scattering part is made of, for example, a woven fabric or a nonwoven fabric, it is also possible to stably detect the predetermined type of information, such as a blood flow velocity, on the specimen, regardless of a change in power of the specimen being pressed against the light scattering part in the measurement.

[0014] In another aspect of the light-emitting sensor device of the present invention, the light scattering part includes foam.

[0015] According to this aspect, the light scattering part includes the foam such as a sponge (or a porous body having a plurality of continuous pores therein). Thus, by virtue of the light scattering part, it is possible to preferably scatter at least one of the light emitted from the irradiating part and the light from the specimen, and it is possible to surely reduce the change in the detection value caused by the shift in relative position relation between the light-emitting sensor device and the specimen. Moreover, if the light scattering part is made of, for example, a sponge, it is also possible to stably detect the predetermined type of information, such as a blood flow velocity, on the specimen, regardless of the change in power of the specimen being pressed against the light scattering part in the measurement.

[0016] In another aspect of the light-emitting sensor device of the present invention, the light scattering part has a plurality of scattering materials dispersed in a transparent member which can transmit the at least one light, each of the plurality of scattering materials having a refractive index which is different from a refractive index of the transparent member, the plurality of scattering materials being capable of scattering the at least one light.

[0017] According to this aspect, by virtue of the light scattering part, it is possible to preferably scatter at least one of the light emitted from the irradiating part and the light from the specimen, and it is possible to surely reduce the change in the detection value caused by the shift in relative position relation between the light-emitting sensor device and the specimen.

[0018] In another aspect of the light-emitting sensor device of the present invention, it is further provided with a front plate disposed to face the substrate, on a front surface side where the specimen is disposed with respect to the substrate, the light scattering part being bonded to the front plate by an adhesive which can transmit the at least one light.

[0019] According to this aspect, the front plate is a light shielding plate-like member where an exit aperture for transmitting the light emitted from the irradiating part and an entrance aperture for transmitting the light from the specimen are formed. The light scattering part is disposed to cover the surface on the specimen side of the front plate, and it is bonded to the front plate by the adhesive. Thus, for example, by that the specimen touches the light scattering part in the detection, it is possible to prevent that the position of the light scattering part on the light-emitting sensor device is shifted. Here, the adhesive can transmit at least one of the light emitted from the irradiating part and the light from the specimen, so that it has practically little or no adverse influence on the light detected by the light receiving part. Incidentally, here, the expression that "the light scattering part is bonded to the front plate by the adhesive" includes, in effect, not only a case where the light scattering part is bonded to the front plate itself by the adhesive but also a case where the light scattering part is bonded to a protective plate disposed on the upper surface of the front plate.

[0020] In another aspect of the light-emitting sensor device of the present invention, it is further provided with a light shielding part, disposed between the irradiating part and the light receiving part on the substrate, for shielding between the irradiating part and the light receiving part from light.

[0021] According to this aspect, for example, it is possible to block the light directly going from the irradiating part to the light receiving part, out of the light emitted from the irradiating part (i.e. the light which is emitted from the irradiating part and which goes to the light receiving part without being applied to the specimen). Thus, it is possible to prevent that the light detected by the light receiving part changes due to the light which directly goes from the irradiating part to the light receiving part. Therefore, it is possible to detect the predetermined type of information, such as a blood flow velocity, on the specimen, more highly accurately.

[0022] In another aspect of the light-emitting sensor device of the present invention, the irradiating part and the light receiving part are integrated on the substrate.

[0023] According to this aspect, the irradiating part and the light receiving part are integrated on the substrate,

so that the layout area for each part is reduced, which further allows miniaturization. Due to the miniaturization, it is possible to extend the use of the light-emitting sensor device, such as making it not of a stationary type but a mobile type.

[0024] In another aspect of the light-emitting sensor device of the present invention, it is further provided with a calculating part for calculating a blood flow velocity associated with the specimen, on the basis of the detected light.

[0025] According to this aspect, by using that the penetration force of light to a living body depends on wavelength, it is possible to measure the blood flow velocity of each of blood vessels which have different depth from the skin surface. Specifically, by applying light to the surface of a living body, the light penetrating into the body is reflected or scattered by red blood cells flowing in the blood vessel, and its wavelength changes due to the Doppler-shift according to the transfer rate of the red blood cells. On the other hand, as for the light reflected or scattered by skin tissue which can be considered immovable with respect to the red blood cells, the light reaches to the light receiving part without any change in the wavelength. By those lights interfering with each other, an optical beat signal corresponding to the Doppler shift amount is detected on the light receiving part. The calculating part performs an arithmetic process, such as frequency analysis, on the optical beat signal, thereby calculating the velocity of the blood flowing in the blood vessel.

[0026] In another aspect of the light-emitting sensor device of the present invention, the irradiating part has a semiconductor laser for generating laser light as the light.

[0027] According to this aspect, the laser light can be applied by applying a voltage to the semiconductor of the irradiating part such that an electric current flows with a higher value than a laser oscillation threshold value. The laser light has such a character that it has a different penetration force to a living body or the like depending on a difference in wavelength. By using such a character, it is possible to perform the measurement in different depth of the specimen.

[0028] The operation and other advantages of the present invention will become more apparent from the embodiment explained below.

[0029] As explained in detail above, according to the light-emitting sensor device of the present invention, it is provided with the substrate, the irradiating part, the light receiving part, and the light scattering part. Therefore, it is possible to reduce the change in the detection value caused by the shift in relative position relation between the light-emitting sensor device and the specimen, and thus, it is possible to detect the predetermined type of information, such as a blood flow velocity, on the specimen, highly accurately.

Brief Description of Drawings

[0030]

- 5 [FIG. 1] FIG. 1 is a plan view showing the structure of a sensor part of a blood flow sensor device in a first embodiment.
- [FIG. 2] FIG. 2 is an A-A' cross sectional view in FIG. 1.
- 10 [FIG. 3] FIG. 3 is a plan view showing the structure of a front plate of the blood flow sensor device in the first embodiment.
- [FIG. 4] FIG. 4 is a plan view showing the structure of a scatterer of the blood flow sensor device in the first embodiment.
- 15 [FIG. 5] FIG. 5 is a block diagram showing the structure of the blood flow sensor device in the first embodiment.
- [FIG. 6] FIG. 6 is a conceptual view showing one example of how to use the blood flow sensor device in the first embodiment.
- [FIG. 7] FIG. 7 is a cross sectional view showing a human subcutaneous structure.
- [FIG. 8] FIG. 8 is a conceptual view showing one example of optical paths in the scatterer and a specimen on the blood flow sensor device in the first embodiment.
- 25 [FIG. 9] FIG. 9 is a cross sectional view having the same concept as in FIG. 2 in a first modified example.
- [FIG. 10] FIG. 10 is a cross sectional view having the same concept as in FIG. 2 in a second modified example.
- 30 [FIG. 11] FIG. 11 is a cross sectional view having the same concept as in FIG. 2 in a third modified example.
- [FIG. 12] FIG. 12 is a cross sectional view having the same concept as in FIG. 2 in a fourth modified example.
- 35 [FIG. 13] FIG. 13 is a schematic diagram showing a position relation between the sensor part and the specimen in the measurement of a blood flow velocity by the blood flow sensor device in the first embodiment.
- [FIG. 14] FIG. 14 is a graph showing a relation between a shift amount from a laser diode at a measurement point and signal intensity of an optical beat signal in the measurement of the blood flow velocity by the blood flow sensor device in the first embodiment.
- 40 [FIG. 15] FIG. 15 is a graph showing a relation between a shift amount from a laser diode at a measurement point and signal intensity of an optical beat signal in the measurement of the blood flow velocity by a blood flow sensor device in a comparative example.
- 45 [FIG. 16] FIG. 16 is a graph showing the signal intensity of the optical beat signal detected by the blood flow sensor device in the first embodiment, by com-
- 50
- 55

paring a case where the specimen is pressed slightly against the scatterer with a case where the specimen is pressed firmly against the scatterer.

[FIG. 17] FIG. 17 is a graph showing the signal intensity of the optical beat signal detected by the blood flow sensor device in the comparative example, by comparing a case where the specimen is pressed slightly against the upper surface of the sensor part with a case where the specimen is pressed firmly against the upper surface of the sensor part.

Description of Reference Codes

[0031]

- 100 sensor part
- 110 sensor part substrate
- 120 laser diode
- 150 laser diode drive circuit
- 160 photodiode
- 170 photodiode amplifier
- 180 light shielding wall
- 190 front plate
- 195 protective plate
- 200 scatterer
- 310 A/D converter
- 320 blood flow velocity DSP

Best Mode for Carrying Out the Invention

[0032] Hereinafter, an embodiment of the present invention will be explained with reference to the drawings. Incidentally, the embodiment below exemplifies a blood flow sensor device, which is one example of the light-emitting sensor device of the present invention.

<First Embodiment>

[0033] A blood flow sensor device in a first embodiment will be explained.

[0034] Firstly, the structure of a sensor part of the blood flow sensor device in the first embodiment will be explained with reference to FIG. 1 to FIG. 4.

[0035] FIG. 1 is a plan view showing the structure of the sensor part of the blood flow sensor device in the first embodiment. FIG. 2 is an A-A' cross sectional view in FIG. 1. Incidentally, in FIG. 1, for convenience of explanation, the illustration of a front plate 190, a protective plate 195, and a scatterer 200 shown in FIG. 2 is omitted.

[0036] As shown in FIG. 1 and FIG. 2, a sensor part 100 of the blood flow sensor device in the first embodiment is provided with a sensor part substrate 110, a laser diode 120, an electrode 130, a wire line 140, a laser diode drive circuit 150, a photodiode 160, a photodiode amplifier 170, a light shielding wall 180, a front plate 190, a protective plate 195, and a scatterer 200.

[0037] The sensor part substrate 110 is made of a semiconductor substrate, such as a silicon substrate. On the

sensor part substrate 110, the laser diode 120, the laser diode drive circuit 150, the photodiode 160, and the photodiode amplifier 170 are integrated and disposed.

[0038] The laser diode 120 is one example of the "irradiating part" of the present invention, and it is a semiconductor laser for emitting laser light. The laser diode 120 is electrically connected to the electrode 130 through the wire line 140. The electrode 130 is electrically connected to an electrode pad (not illustrated) disposed on the bottom of the sensor part substrate 100 by wiring (not illustrate) which penetrates the sensor part substrate 110, and it can drive the laser diode 120 by current injection from the exterior of the sensor part 100.

[0039] The laser diode drive circuit 150 is a circuit for controlling the drive of the laser diode 120, and it controls the amount of an electric current injected to the laser diode 120.

[0040] The photodiode 160 is one example of the "light receiving part" of the present invention, and it functions as a light detector for detecting the light reflected or scattered from a specimen (more specifically, the light scattered by the scatterer 200 described later). Specifically, the photodiode 160 can obtain information about light intensity by converting the light to an electric signal. The photodiode 160 is disposed in parallel with the laser diode 120 on the sensor part substrate 110.

[0041] The photodiode amplifier 170 is an amplifier circuit for amplifying the electric signal obtained by the photodiode 160. The photodiode amplifier 170 is electrically connected to the electric pad (not illustrated) disposed on the bottom of the sensor part substrate 100 by the wiring (not illustrate) which penetrates the sensor part substrate 110, and it can output the amplified electric signal to the exterior. The photodiode amplifier 170 is electrically connected to an A/D (Analog to Digital) converter 310 (refer to FIG. 5 described later) disposed in the exterior of the sensor part 100.

[0042] The light shielding wall 180 is formed in a wall shape on the sensor part substrate 110, including a light shielding material. The light shielding wall 180 has: a first light shielding part 181 formed along a circumference on the sensor part substrate 110; and a second light shielding part 182 formed between the laser diode 120 and the photodiode 160 on the sensor part substrate 110. The first light shielding part 181 is formed to surround all the laser diode 120, the electrode 130, the wire line 140, the laser diode drive circuit 160, the photo diode 160, and the photodiode amplifier 170, viewed in a two-dimensional manner on the sensor part substrate 110. By virtue of the first light shielding part 181, it is possible to prevent the light from the surroundings of the sensor part 100 from entering into the sensor part 100 (i.e. inner than the first light shielding part 181 on the sensor part substrate 110). The second light shielding part 182 is formed to connect a portion formed along one side of the sensor part substrate 110 of the first light shielding part 181 and a portion formed along the other side opposed to the one side of the first light shielding part 181, between the laser

diode 120 and the photodiode 160 on the sensor part substrate 110. By virtue of the second light shielding part 182, it is possible to shield between the laser diode 120 and the photodiode 160 from the light. Thus, for example, it is possible to block the light going to the photodiode 160 as it is, without being applied to the specimen, out of the light emitted from the laser diode 120. In other words, it is possible to prevent the light which does not have to be detected by the photodiode 160 from entering the photodiode 160 from the laser diode 120 side to the photodiode 160 side on the sensor part substrate 110, thereby increasing the detection accuracy.

[0043] The front plate 190 is a substrate including a light shielding material, and it is disposed above the laser diode 120, the photodiode 170, and the like (in other words, such that it faces the sensor part substrate 110 via the light shielding wall 180). Incidentally, the plate thickness of the front plate 190 is, for example, about 300 μm .

[0044] FIG. 3 is a plan view showing the structure of the front plate of the blood flow sensor device in the first embodiment.

[0045] As shown in FIG. 2 and FIG. 3, in the front plate 190, an exit aperture 191 for letting out or emitting the light from the laser diode 120 to the exterior is opened, and an entrance aperture 192 for letting in the light reflected or scattered from the specimen is formed in a pinhole shape. The pinhole-shaped formation of the entrance aperture 192 allows the incidence of only the light from directly above (i.e. in a top-to-bottom direction in FIG. 2). Thus, it is possible to prevent the light that does not have to be detected from entering the photodiode 160, thereby increasing the detection accuracy. Incidentally, the diameter of the entrance aperture 192 formed in the pinhole shape is, for example, about 40 μm .

[0046] In FIG. 2, the protective plate 195 is disposed on the upper surface side of the front plate 190. The protective plate 195 is made of a transparent substrate and can transmit the light from the laser diode 120 and the light from the specimen. The protective plate 195 is disposed to overlap the entire surface of the front plate 190. As the protective plate 195, for example, a resin substrate, a glass substrate, or the like can be used. The protective plate 195 can increase the durability of the sensor part 100.

[0047] The scatterer 200 is one example of the "light scattering part" of the present invention, and it is made of a fibrous material, such as a woven fabric and a non-woven fabric. The scatterer 200 is bonded to the protective plate 195 by an adhesive which can transmit the light from the laser diode 120 and the light from the specimen. Thus, in the measurement, it is possible to prevent that the specimen touches the scatterer 200 and shifts the position of the scatterer 200 on the sensor part 100.

[0048] FIG. 4 is a plan view showing the structure of the scatterer of the blood flow sensor device in the first embodiment.

[0049] In FIG. 2 and FIG. 4, the scatterer 200 is formed

to overlap the entire surface of the protective plate 195, on the upper surface side of the protective plate 195. The scatterer 200 is made of the fibrous material as described above, so that it can scatter the light from the laser diode 120 and the light reflected or scattered from the specimen. It is only necessary for the scatterer 200 to scatter the light from the laser diode 120 and the light reflected or scattered from the specimen. The scatterer 200 may be made of not only the fibrous material but also foam, such as a sponge, and a porous body. Alternatively, the scatterer 200 may be made by dispersing small particles made of polymer resin, glass, or the like, which have different refraction indexes from that of a transparent material, in the transparent material made of plastic, glass, or the like. Incidentally, an effect by the scatterer 200 will be detailed later. In the embodiment, in particular, the sensor part 100 is provided with the scatterer 200, so that it is possible to stably detect the blood flow velocity of the specimen.

[0050] Next, the structure of the entire blood flow sensor device in the first embodiment will be explained with reference to FIG. 5.

[0051] FIG. 5 is a block diagram showing the structure of the blood flow sensor device in the first embodiment.

[0052] In FIG. 5, the blood flow sensor device in the first embodiment is provided with an A/D converter 310 and a blood flow velocity digital signal processor (DSP) 320, in addition to the aforementioned sensor part 100.

[0053] The A/D converter 310 converts the electric signal outputted from the photodiode amplifier 170, from an analog signal to a digital signal. In other words, the electric signal obtained by the photodiode 160 is amplified by the photodiode amplifier 170, and then it is converted to the digital signal by the A/D converter 310. The A/D converter 310 outputs the digital signal to the blood flow velocity DSP 320.

[0054] The blood flow velocity DSP 320 is one example of the "calculating part" of the present invention, and it calculates the blood flow velocity by performing a predetermined arithmetic process on the digital signal inputted from the A/D converter 310.

[0055] Next, the measurement of the blood flow velocity by the blood flow sensor device in the first embodiment will be explained with reference to FIG. 6 and FIG. 7 in addition to FIG. 5.

[0056] FIG. 6 is a conceptual view showing one example of how to use the blood flow sensor device in the first embodiment. FIG. 7 is a cross sectional view showing a human subcutaneous structure.

[0057] As shown in FIG. 6, the blood flow sensor device in the first embodiment measures the blood flow velocity by irradiating a fingertip 500, which is one example of the specimen, with laser light with a predetermined wavelength (e.g. infrared light with a wavelength of 780nm, 830nm, or 1300nm) by using the laser diode 120. At this time, a portion irradiated with the laser light is more desirably a portion in which blood capillaries are distributed densely in a position relatively close to the epidermis (e.g.

hand, leg, face, ear, or the like). Incidentally, in FIG. 6 and FIG. 7, an arrow P1 conceptually shows the light emitted from the sensor part 100. Moreover, in the measurement of the blood flow velocity, the blood flow sensor device in the first embodiment is typically used in the condition that the fingertip 500 touches the upper surface of the sensor part 100 (i.e. the upper surface of the scatterer 200); however, for convenience of explanation, FIG. 6 shows a gap between the fingertip 500 and the sensor part 100. However, according to the blood flow sensor device in the first embodiment, it is possible to measure the blood flow velocity even if the fingertip 500 does not touch the upper surface of the sensor part 100.

[0058] Here, as shown in FIG. 7, in the human subcutaneous structure, an arteriole 410 and a venule 420 are distributed in the dermis located between the epidermis and the subcutaneous tissue. Then, blood capillaries 430 branching from the arteriole 410 are distributed toward to the vicinity of the epidermis, and one ends are connected to the venule 420.

[0059] In FIG. 6 and FIG. 7, the laser light applied to the fingertip 500 penetrates to depth according to its wavelength, and it is reflected or scattered by the body tissue of the fingertip 500, such as blood flowing in blood vessels like the blood capillaries or the like and skin cells which constitute the epidermis. In general, the light with a longer wavelength allows the measurement in a deeper portion. Incidentally, in FIG. 6 and FIG. 7, an arrow P2 conceptually shows the light entering the sensor part 100 after being reflected or scattered by the body tissue of the fingertip 500. Then, the Doppler shift occurs in the light reflected or scattered by red blood cells flowing in the blood vessels, and the wavelength of the light changes depending on the transfer rate of the red blood cells or the rate at which the blood flows (i.e. the blood flowing velocity). On the other hand, as for the light reflected or scattered by the skin cells or the like which can be considered immovable with respect to the red blood cells, the wavelength of the light does not change. By those lights interfering with each other, an optical beat signal corresponding to the Doppler shift amount is detected on the photodiode 160 (refer to FIG. 5). The blood flow velocity DSP 320 (refer to FIG. 5) performs frequency analysis on the optical beat signal detected by the photodiode 160 and calculates the Doppler shift amount, thereby calculating the blood flow velocity.

[0060] Next, the scatterer of the blood flow sensor device in the first embodiment will be explained together with the operations of the blood flow sensor device in the first embodiment, with reference to FIG. 8 in addition to FIG. 5.

[0061] FIG. 8 is a conceptual view showing one example of optical paths in the scatterer and the specimen on the blood flow sensor device in the first embodiment.

[0062] In FIG. 8, in the operation of the blood flow sensor device in the first embodiment, firstly, the light with a predetermined wavelength is emitted from the laser diode 120, under the control by the laser diode drive circuit

150 (refer to FIG. 5). The emitted light passes through the exit aperture 191 of the front plate 190, penetrates through the protective plate 195, and enters the scatterer 200. The light entering the scatterer 200 is scattered within the scatterer 200 and then enters the fingertip 500, which is one example of the specimen. More specifically, the light entering the scatterer 200 is reflected on the surfaces of the fibrous materials 210 which constitute the scatterer 200, is transmitted through the fibrous materials 210, or is refracted on the surfaces of the fibrous materials 210. The light entering the scatterer 200, as described above with reference to FIG. 6 and FIG. 7, penetrates to the depth according to its wavelength, and it is reflected or scattered by the body tissue of the fingertip 500, such as blood flowing in blood vessels and skin cells. The Doppler shift occurs in the light reflected or scattered by the red blood cells flowing in the blood vessels, and the wavelength of the light changes depending on the transfer rate of the red blood cells. On the other hand, as for the light reflected or scattered by stationary tissue, such as the skin cells which can be considered immovable with respect to the red blood cells, the wavelength of the light does not change. Incidentally, in FIG. 8, a route R1 shows one example of the optical path in the scatterer 200 and the fingertip 500 with regard to the light scattered or reflected by the red blood cells in the fingertip 500, and a route R2 shows one example of the optical path in the scatterer 200 and the fingertip 500 with regard to the light scattered or reflected by the stationary tissue, such as the skin cells, in the fingertip 500. The light reflected or scattered in the fingertip 500 as described above enters the scatterer 200 again. The light entering from the fingertip 500 to the scatterer 200 is scattered again within the scatterer 200, penetrates through the protective plate 195, and enters the photodiode 160 via the entrance aperture 192 of the front plate 190. By that the light reflected or scattered by the red blood cells and the light scattered or reflected by the stationary tissue, which are included in the light entering the photodiode 160, interfere with each other, the optical beat signal corresponding to the Doppler shift amount is detected on the photodiode 160.

[0063] Here, particularly in the embodiment, the sensor part 100 is provided with the scatterer 200, so that the light emitted from the laser diode 120 is reflected or scattered on the fingertip 500, which is one example of the specimen, and it is scattered by the scatterer 200 in the middle of the route to the photodiode 150, as described above. By this, as explained later, it is possible to stably detect the blood flow velocity. Incidentally, in the embodiment, the scatterer 200 is disposed to overlap the entire surface of the protective plate 195 such that the light emitted from the laser diode 120 is scattered before the light enters the fingertip 500 and such that the light emitted from the fingertip 500 after being reflected or scattered in the fingertip 500 is scattered before the light enters the photodiode 160. However, the scatterer 200 may be disposed only on the laser diode 120 side

on the protective plate 195 so that only the light emitted from the laser diode 120 is scattered before the light enters the fingertip 500. Alternatively, the scatterer 200 may be disposed only on the photodiode 160 side on the protective plate 195 so that the light emitted from the fingertip 500 after being reflected or scattered in the fingertip 500 is scattered before the light enters the photodiode 160. In any case, the scattering of the light in the scatterer 200 can appropriately provide an effect of increasing stability in the detection of the blood flow velocity.

[0064] Moreover, the sensor part 100 of the blood flow sensor device in the first embodiment has a relatively simple structure, which facilitates mass production. In other words, the sensor part 100 has such a relatively simple structure that the scatterer 200 is provided for a sensor part main body, which is provided with: the sensor part substrate 110 on which the laser diode 120, the photodiode 160, and the like are integrated; the light shielding wall 180; the front plate 190; and the protective plate 195. Thus, the blood flow sensor device in the first embodiment is suitable for the mass production.

[0065] In addition, particularly in the embodiment, the sensor part 100 is provided with the scatterer 200, so that it is possible to almost or completely eliminate the risk of the laser exposure of the specimen by the laser light emitted from the laser diode 120. In other words, since the light emitted from the laser diode 120 is scattered by the scatterer 200, only the scattered light is let out or emitted to the exterior of the sensor part 100. Thus, the risk of the laser exposure of the specimen almost or completely disappears. Incidentally, in the blood flow sensor device in the first embodiment, it is enough to perform an appropriate measurement if the laser light emitted from the laser diode 120 has a power of about several milliwatt at most. Even if the laser light emitted from the laser diode 120 directly enters the specimen without being scattered by the scatterer 200, although there is practically almost no risk of the laser exposure of the specimen, it is possible to further reduce the risk of the laser exposure by being scattered by the scatterer 200.

<First Modified Example>

A blood flow sensor apparatus in a first modified example will be explained with reference to FIG. 9.

[0066] FIG. 9 is a cross sectional view having the same concept as in FIG. 2 in the first modified example. Incidentally, in FIG. 9, the same constituents as those in the first embodiment shown in FIG. 1 to FIG. 8 will carry the same reference numerals, and the explanation thereof will be omitted, as occasion demands.

[0067] In FIG. 9, the blood flow sensor apparatus in the first modified example is different from the blood flow sensor apparatus in the first embodiment described above in the point that it is provided with a scatterer 201 instead of the scatterer 200 in the first embodiment described above, and it is constructed in substantially the same manner as the blood flow sensor apparatus in the first embodiment described above in other points.

[0068] As shown in FIG. 9, the scatterer 201 is disposed to wrap around the protective plate 195, the front plate 190, and the light shielding wall 180 from the upper surface side of the protective plate 195. The scatterer 201 is made of a fibrous material, such as a woven fabric and a nonwoven fabric, as in the scatterer 200 in the first embodiment. Thus, it is possible to protect a sensor part main body 100a (i.e. a portion other than the scatterer 201 out of the sensor part 100) by using the scatterer 201. In other words, it is possible to reduce the situation that the sensor part main body 100a is exposed to the exterior to cause the sensor part main body 100a to get dirty and damaged, by virtue of the scatterer 201. Incidentally, the scatterer 201 may wrap around the entire sensor part main body 100a. In this case, it is possible to increase the effect of protecting the sensor part main body 100a by virtue of the scatterer 201.

<Second Modified Example>

A blood flow sensor apparatus in a second modified example will be explained with reference to FIG. 10.

[0069] FIG. 10 is a cross sectional view having the same concept as in FIG. 2 in the second modified example. Incidentally, in FIG. 10, the same constituents as those in the first embodiment shown in FIG. 1 to FIG. 8 will carry the same reference numerals, and the explanation thereof will be omitted, as occasion demands.

[0070] In FIG. 10, the blood flow sensor apparatus in the second modified example is different from the blood flow sensor apparatus in the first embodiment described above in the point that it is provided with a scatterer 202 instead of the scatterer 200 in the first embodiment described above and further with a structure 410, and it is constructed in substantially the same manner as the blood flow sensor apparatus in the first embodiment described above in other points.

[0071] As shown in FIG. 10, in the sensor part 100 of the blood flow sensor apparatus in the second modified example, the sensor part main body 100a (i.e. a portion other than the scatterer 202 out of the sensor part 100; namely, the sensor part substrate 110, the laser diode 120 (and the laser diode drive 150), the photodiode 160 (and the photodiode amplifier 170), the light shielding wall 180, the front plate 190 and the protective plate 195) is embedded or implanted within the structure 410, with the protective plate 195 exposed from the upper surface side of the structure 410, and the scatterer 202 is disposed to overlap all the upper surfaces of the structure 410 and the protective plate 195. The structure 410 can be formed of, for example, resin, glass, metal, or the like. The scatterer 202 is made of a fibrous material, such as a woven fabric and a nonwoven fabric, as in the scatterer 200 in the first embodiment.

[0072] According to the blood flow sensor apparatus in the second modified example as constructed above, it is possible to protect the sensor part main body 100a by using the scatterer 202 and the structure 410. Moreover, the structure 410 can be protected by the scatterer 202 from the upper surface side thereof.

<Third Modified Example>

A blood flow sensor apparatus in a third modified example will be explained with reference to FIG. 11.

[0073] FIG. 11 is a cross sectional view having the same concept as in FIG. 2 in the third modified example. Incidentally, in FIG. 11, the same constituents as those in the first embodiment shown in FIG. 1 to FIG. 8 will carry the same reference numerals, and the explanation thereof will be omitted, as occasion demands.

[0074] In FIG. 11, the blood flow sensor apparatus in the third modified example is different from the blood flow sensor apparatus in the first embodiment described above in the point that it is provided with a protective plate 196 and a scatterer 203 instead of the protective plate 195 and the scatterer 200 in the first embodiment described above, respectively, and further with a structure 420, and it is constructed in substantially the same manner as the blood flow sensor apparatus in the first embodiment described above in other points.

[0075] As shown in FIG. 11, in the sensor part 100 of the blood flow sensor apparatus in the third modified example, a sensor part main body 100b (i.e. a portion other than the scatterer 203 and the protective plate 196 out of the sensor part 100; namely, the sensor part substrate 110, the laser diode 120 (and the laser diode drive 150), the photodiode 160 (and the photodiode amplifier 170), the light shielding wall 180 and the front plate 190) is embedded or implanted within the structure 420, with the protective plate 196 exposed from the upper surface side of the structure 420, and the protective plate 196 is disposed to overlap all the upper surfaces of the structure 420 and the front plate 190, and the scatterer 203 is disposed to overlap the upper surface of the protective plate 196. The structure 420 can be formed of, for example, resin, glass, metal, or the like. The scatterer 203 is made of a fibrous material, such as a woven fabric and a non-woven fabric, as in the scatterer 200 in the first embodiment.

[0076] According to the blood flow sensor apparatus in the third modified example as constructed above, it is possible to protect the sensor part main body 100a by using the scatterer 203, the protective plate 196, and the structure 420. Moreover, the structure 420 can be protected by the protective plate 196 and the scatterer 203 from the upper surface side thereof.

<Fourth Modified Example>

A blood flow sensor apparatus in a fourth modified example will be explained with reference to FIG. 12.

[0077] FIG. 12 is a cross sectional view having the same concept as in FIG. 2 in the fourth modified example. Incidentally, in FIG. 12, the same constituents as those in the first embodiment shown in FIG. 1 to FIG. 8 will carry the same reference numerals, and the explanation thereof will be omitted, as occasion demands.

[0078] In FIG. 12, the blood flow sensor apparatus in the fourth modified example is different from the blood flow sensor apparatus in the first embodiment described above in the point that it is provided further with a pro-

TECTIVE member 510, and it is constructed in substantially the same manner as the blood flow sensor apparatus in the first embodiment described above in other points.

[0079] As shown in FIG. 12, the protective member 510 is disposed to overlap the upper surface of the scatterer 200 (in other words, a surface opposed to the specimen in the scatterer 200). The protective member 510 is made of a transparent substrate, and it can transmit the light from the laser diode 120 and the light reflected or scattered from the specimen. As the protective member 510, for example, a resin substrate, a glass substrate, or the like can be used.

[0080] Thus, it is possible to the situation that the scatterer 200 is exposed to the exterior, or the specimen touches the scatterer 200 to cause the scatterer 200 to get dirty and damaged, by virtue of the protective member 510. In particular, in a case where the scatterer 200 is formed of foam, such as a sponge, and a porous body, the scatterer 200 tends to get dirty relatively, so that it is extremely useful in practice that the scatterer 200 can be protected by the protective member 510 as described above.

[0081] Next, the effect by the scatterer of the blood flow sensor device in the first embodiment will be detailed with reference to FIG. 13 to FIG. 17.

[0082] FIG. 13 is a schematic diagram showing a position relation between the sensor part and the specimen in the measurement of the blood flow velocity by the blood flow sensor device in the first embodiment. FIG. 14 is a graph showing a relation between a shift amount from the laser diode at a measurement point and signal intensity of the optical beat signal in the measurement of the blood flow velocity by the blood flow sensor device in the first embodiment.

[0083] FIG. 14 shows the relation between a shift amount d from the laser diode 120 at a measurement point Q1 (refer to FIG. 13) and signal intensity of the optical beat signal detected by the photodiode 160, in a case where the blood flow velocity of the fingertip 500, which is one example of the specimen, is measured by using the blood flow sensor device in the first embodiment. Incidentally, in this measurement, a towel fiber is used as the scatterer 200.

[0084] Here, in FIG. 13, the measurement point Q1 is a point of the fingertip 500 with the closest distance from the photodiode 160. The shift amount d is the amount of shift from the laser diode 120 at the measurement point Q1 (more accurately, a distance between the measurement point Q1 and a portion of the laser diode 120 where the light emits in a case where the sensor 100 is viewed from directly above. A distance g is a distance between the upper surface of the sensor part main body 100a (i.e. a portion other than the scatterer 200 out of the sensor part 100) and the measurement point Q1. In the measurement of the blood flow velocity, the fingertip 500 touches the scatterer 200, so that the distance g almost or completely matches the thickness of the scatterer 200. Incidentally, in FIG. 13, an arrow P3 conceptually shows

the light emitted from the laser diode 120, and an arrow P4 conceptually shows the light entering the photodiode 160.

[0085] In FIG. 14, data D1 shows the relation between the shift amount d and the signal intensity of the optical beat signal, in a case where the blood flow velocity is measured with a distance g of 2mm between the upper surface of the sensor part main body 100a and the measurement point Q1 (in other words, with a thickness of the scatterer 200 of 2mm). Data D2 shows the relation between the shift amount d and the signal intensity of the optical beat signal, in a case where the blood flow velocity is measured with a distance g of 8mm between the upper surface of the sensor part main body 100a and the measurement point Q1 (in other words, with a thickness of the scatterer 200 of 8mm).

[0086] FIG. 15 is a graph showing a relation between a shift amount from a laser diode at a measurement point and signal intensity of an optical beat signal in the measurement of the blood flow velocity by a blood flow sensor device in a comparative example. Here, the blood flow sensor device in the comparative example is different from the blood flow sensor device in the first embodiment in the point that it is not provided with the scatterer 200, and it is constructed in substantially the same manner as the blood flow sensor apparatus in the first embodiment described above in other points. In other words, in FIG. 13, the sensor part of the blood flow sensor device in the comparative example corresponds to the sensor part main body 100a of the blood flow sensor apparatus in the first embodiment.

[0087] In FIG. 15, data E1 shows the relation between the shift amount d and the signal intensity of the optical beat signal, in a case where the blood flow velocity is measured with a distance g of 0mm between the upper surface of the sensor part of the blood flow sensor device in the comparative example and the measurement point Q1 (in other words, when the fingertip 500 touches the upper surface of the sensor part of the blood flow sensor device in the comparative example). Data E2 shows the relation between the shift amount d and the signal intensity of the optical beat signal, in a case where the blood flow velocity is measured with a distance g of 1mm between the upper surface of the sensor part of the blood flow sensor device in the comparative example and the measurement point Q1. Data E3 shows the relation between the shift amount d and the signal intensity of the optical beat signal, in a case where the blood flow velocity is measured with a distance g of 2mm between the upper surface of the sensor part of the blood flow sensor device in the comparative example and the measurement point Q1.

[0088] As shown in the data E1, E2, and E3, in the blood flow sensor device in the comparative example, the detected signal intensity of the optical beat signal rapidly decreases in accordance with an increase in the shift amount d. In other words, if the position relation between the fingertip 500 and the sensor part changes,

there is a possibility that the blood flow velocity cannot be stably measured.

[0089] However, as shown in the data D1 and D2 in FIG. 14, in the blood flow sensor device in the first embodiment, the detected signal intensity of the optical beat signal hardly decreases even if the shift amount d increases, in comparison with the blood flow sensor device in the comparative example. In other words, the range of the shift amount d where the blood flow velocity can be measured is wider than in the blood flow sensor device in the comparative example. That is, as shown in the data E1, E2, and E3 in FIG. 15, the range of the shift amount d where the blood flow velocity can be measured is less than or equal to about 1mm at the widest in the blood flow sensor device in the comparative example, whereas as shown in the data D1 in FIG. 14, the range of the shift amount d where the blood flow velocity can be measured is less than or equal to about 2mm in the blood flow sensor device in the first embodiment. Moreover, as shown in the data D2 in FIG. 14, in the case where the distance g is 8mm, i.e. in the case where the thickness of the scatterer 200 is 8mm, even if the shift amount d is e.g. 5mm, the reduction in the detected signal intensity of the optical beat signal is small, and thus the blood flow velocity can be measured well. As described above, in the blood flow sensor device in the first embodiment, it is possible to reduce the change in the signal intensity of the optical beat signal detected by the photodiode 160, which is caused by the shift in the relative position relation between the sensor part 100 and the fingertip 500 as the specimen, in comparison with the blood flow sensor device in the comparative example. In other words, in the blood flow sensor device in the first embodiment, the range of the shift amount d where the appropriate detection value can be obtained is wider (i.e. the acceptable range of the shift amount d allowed to obtain the appropriate detection value in the measurement is wider) than in the blood flow sensor device in the comparative example. Here, the blood flow sensor device in the first embodiment and the blood flow sensor device in the comparative example are different in whether or not the scatterer 200 is provided, and they are constructed in substantially the same manner in other points. In other words, the effect of reducing the change in the signal intensity of the optical beat signal, which is caused by the shift in the relative position relation between the sensor part and the specimen, can be obtained because the blood flow sensor device in the first embodiment is provided with the scatterer 200.

[0090] Therefore, according to the blood flow sensor device in the first embodiment, the sensor par 100 is provided with the scatterer 200, so that it is possible to stably detect the blood flow velocity of the fingertip 500 on the basis of the optical beat signal. As a result, it is possible to increase the reliability of the detection value detected by the blood flow sensor device.

[0091] Incidentally FIG. 14 shows the case where the towel fiber is used as the scatterer; however, the inven-

tors in the present application obtain substantially the same measurement results even if a nonwoven fabric and a sponge are used as the scatterer.

[0092] Moreover, according to the blood flow sensor device in the first embodiment, the sensor part 100 is provided with the scatterer 200, so that it is also possible to limit or prevent that the detected signal intensity of the optical beat signal is reduced by applying a relatively large pressure to the specimen.

[0093] FIG. 16 is a graph showing the signal intensity of the optical beat signal detected by the blood flow sensor device in the first embodiment, by comparing a case where the specimen is pressed slightly against the scatterer with a case where the specimen is pressed firmly against the scatterer. FIG. 17 is a graph showing the signal intensity of the optical beat signal detected by the blood flow sensor device in the comparative example, by comparing a case where the specimen is pressed slightly against the upper surface of the sensor part with a case where the specimen is pressed firmly against the upper surface of the sensor part. Incidentally, in FIG. 16 and FIG. 17, the horizontal axis indicates a time axis, and the vertical axis indicates the intensity of an output signal from the photodiode (PD output). The signal intensity of the optical beat signal means the amplitude of the optical beat signal.

[0094] FIG. 16 shows a change over time in the detected signal intensity of the optical beat signal in the case where the blood flow velocity is measured in the condition that the fingertip, which is one example of the specimen, is pressed lightly against the scatterer 200 in a period T1 and the blood flow velocity is measured in the condition that the fingertip, which is one example of the specimen, is pressed firmly against the scatterer 200 in a period T2 following the period T1, by using the blood flow sensor device in the first embodiment. Incidentally, in this measurement, the towel fiber is used as the scatterer 200.

[0095] As shown in FIG. 16, according to the blood flow sensor device in the first embodiment, the signal intensity of the optical beat signal rarely changes (i.e. almost the same) between the case where the fingertip is pressed lightly against the scatterer 200 and the case where the fingertip is pressed firmly against the scatterer 200.

[0096] On the other hand, FIG. 17 shows a change over time in the detected signal intensity of the optical beat signal in the case where the blood flow velocity is measured in the condition that the fingertip, which is one example of the specimen, is pressed lightly against the sensor part (more specifically, e.g. the upper surface of the protective plate made of a resin substrate, a glass substrate, or the like) in a period T3 and the blood flow velocity is measured in the condition that the fingertip, which is one example of the specimen, is pressed firmly against the sensor part in a period T4 following the period T3, by using the blood flow sensor device in the comparative example.

[0097] As shown in FIG. 17, according to the blood flow sensor device in the comparative example, the signal intensity of the optical beat signal decreases in the case where the fingertip is pressed firmly against the sensor part, in comparison with the case where the fingertip is pressed lightly against the sensor part. One of the causes of this phenomenon is that a relatively large pressure is applied on the fingertip by the fingertip being pressed firmly against the sensor part and thus the blood capillaries of the fingertip tend to be occluded or blocked.

[0098] However, the blood flow sensor device in the first embodiment is provided with the scatterer 200 made of the towel fiber in this measurement, so that it is possible to prevent that a relatively large pressure is applied to the fingertip, which is one example of the specimen, and it is also possible to limit or control that the blood capillaries of the fingertip tend to be occluded or blocked. Thus, as shown in FIG. 16, the signal intensity of the optical beat signal rarely changes between the case where the fingertip is pressed lightly against the scatterer 200 and the case where the fingertip is pressed firmly against the scatterer 200. Therefore, it is possible to reduce or prevent that the measured blood flow velocity changes depending on a change in power of the fingertip being pressed against the upper surface of the sensor part 100 (or the upper part of the scatterer 200 in the first embodiment). As a result, it is possible to stably measure the blood flow velocity. Incidentally, the effect that the blood flow velocity can be stably measured regardless of the change in power for the specimen being pressed against the sensor part can be obtained not only in the case where the scatterer 200 is made of the towel fiber but also in a case where the scatterer 200 is made of another fibrous material or sponge or the like and is softer or has higher elasticity than the protective plate and the front plate.

[0099] As explained in detail above, according to the blood flow sensor device in the first embodiment, it is provided with the scatterer 200, so that the change in the detection value (i.e. the blood flow velocity) caused by the shift in the relative position relation between the blood flow sensor device and the specimen is reduced, and the blood flow velocity of the specimen can be stably detected. Moreover, it is possible to reduce that the measured blood flow velocity changes due to the change in power of the specimen being pressed against the upper surface of the sensor part.

The present invention is not limited to the aforementioned example, but various changes may be made, if desired, without departing from the essence or spirit of the invention which can be read from the claims and the entire specification. A light-emitting sensor device, which involves such changes, is also intended to be within the technical scope of the present invention.

Industrial Applicability

[0100] The light-emitting sensor device of the present

invention can be applied to a blood flow sensor device or the like capable of measuring a blood flow velocity or the like.

1, further comprising a calculating part for calculating a blood flow velocity associated with the specimen, on the basis of the detected light.

Claims

- 1. A light-emitting sensor device comprising:
 - a substrate;
 - an irradiating part, disposed on said substrate, for applying light to a specimen;
 - a light receiving part, disposed on said substrate, for detecting light from the specimen caused by the applied light;
 - a light scattering part, disposed at least one of between said irradiating part and the specimen and between the specimen and said light receiving part, for scattering at least one of light emitted from said irradiating part and the light from the specimen.
- 2. The light-emitting sensor device according to claim 1, wherein said light scattering part includes a fibrous material.
- 3. The light-emitting sensor device according to claim 1, wherein said light scattering part includes foam.
- 4. The light-emitting sensor device according to claim 1, wherein said light scattering part has a plurality of scattering materials dispersed in a transparent member which can transmit the at least one light, each of the plurality of scattering materials having a refractive index which is different from a refractive index of the transparent member, the plurality of scattering materials being capable of scattering the at least one light.
- 5. The light-emitting sensor device according to claim 1, further comprising a front plate disposed to face said substrate, on a front surface side where the specimen is disposed with respect to said substrate, said light scattering part being bonded to said front plate by an adhesive which can transmit the at least one light.
- 6. The light-emitting sensor device according to claim 1, further comprising a light shielding part, disposed between said irradiating part and said light receiving part on said substrate, for shielding between said irradiating part and said light receiving part from light.
- 7. The light-emitting sensor device according to claim 1, wherein said irradiating part and said light receiving part are integrated on said substrate.
- 8. The light-emitting sensor device according to claim

5 9. The light-emitting sensor device according to claim 1, wherein said irradiating part has a semiconductor laser for generating laser light as the light.

10

15

20

25

30

35

40

45

50

55

EP 2 277 440 A1

[FIG. 1]

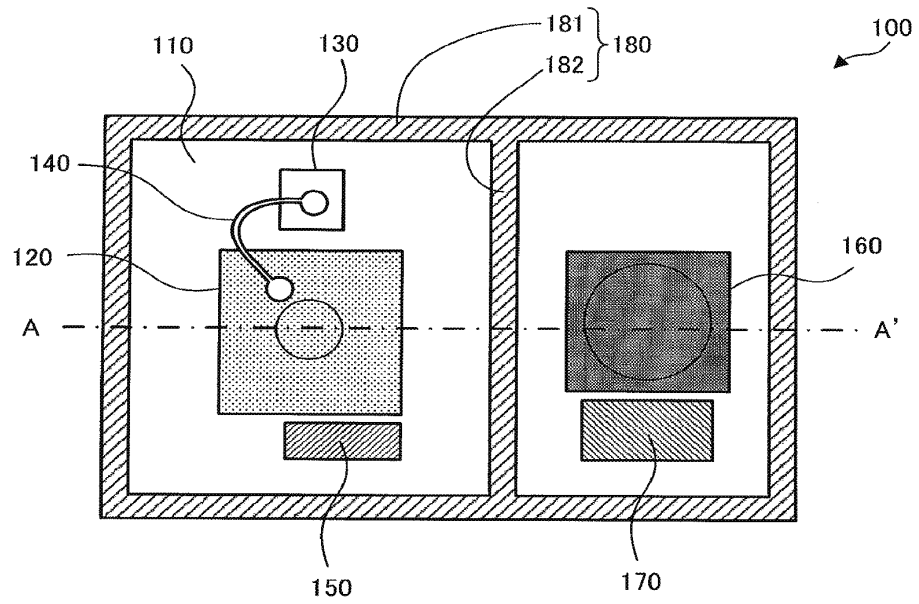

EP 2 277 440 A1

[FIG. 2]

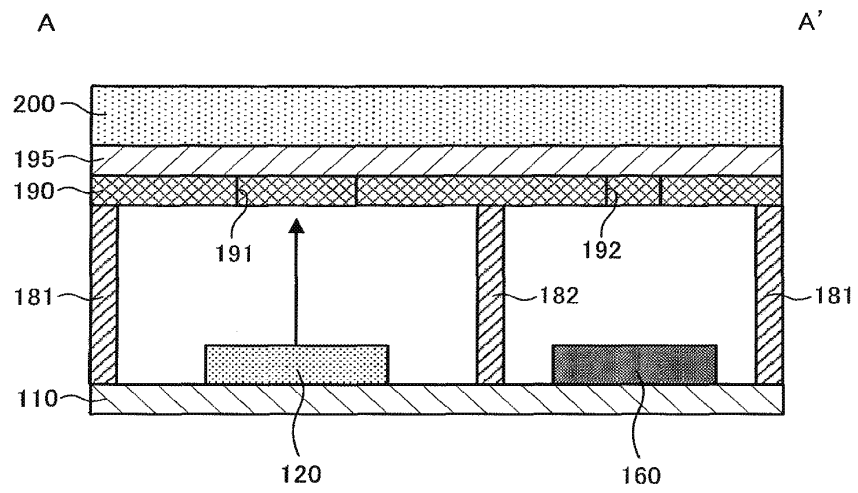

EP 2 277 440 A1

[FIG. 3]

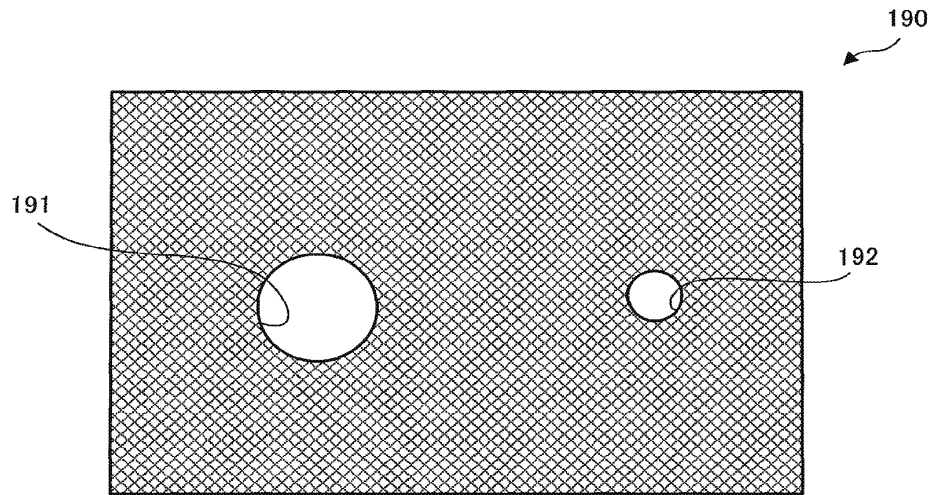

EP 2 277 440 A1

[FIG. 4]

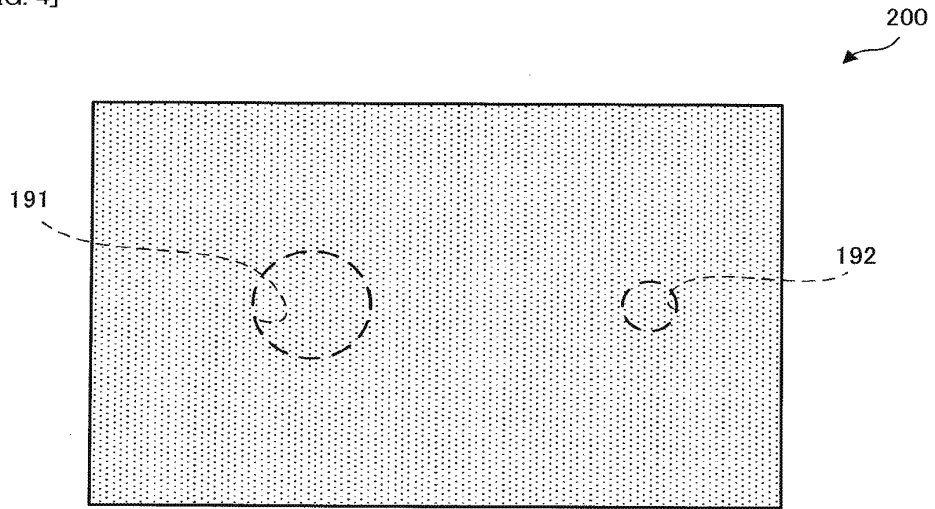

[FIG. 5]

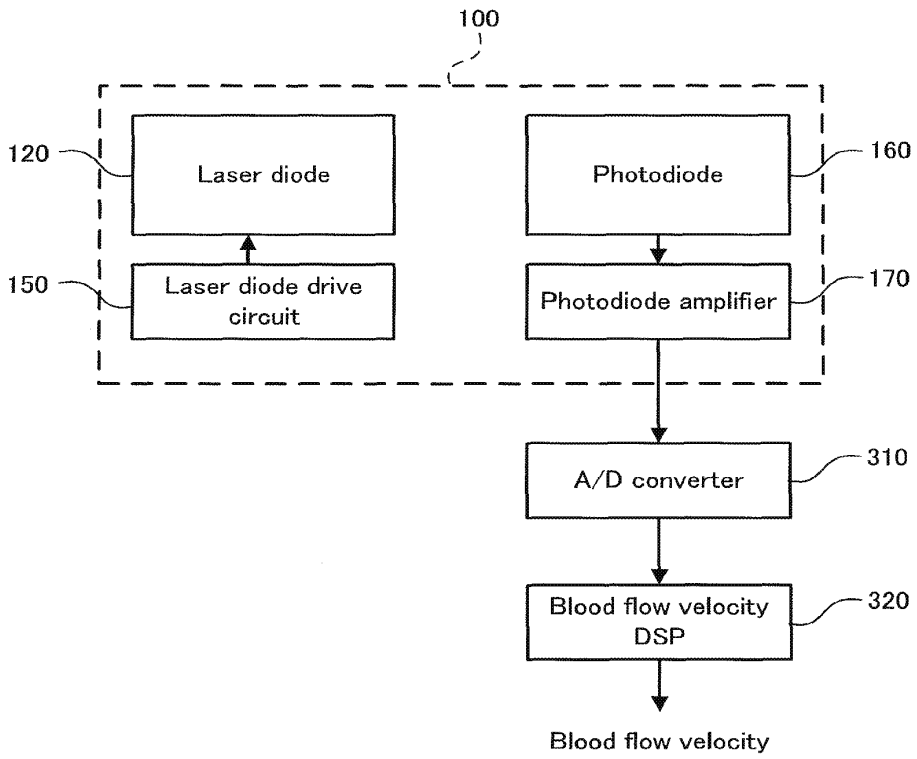

EP 2 277 440 A1

[FIG. 6]

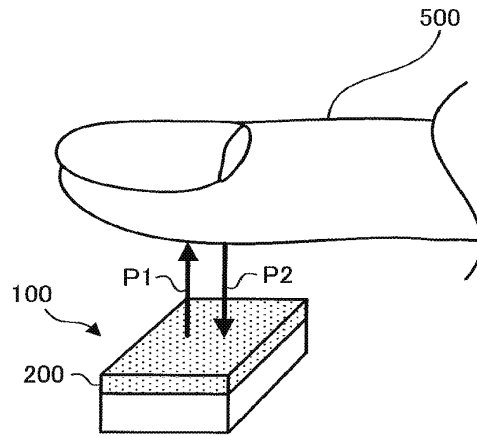

[FIG. 7]

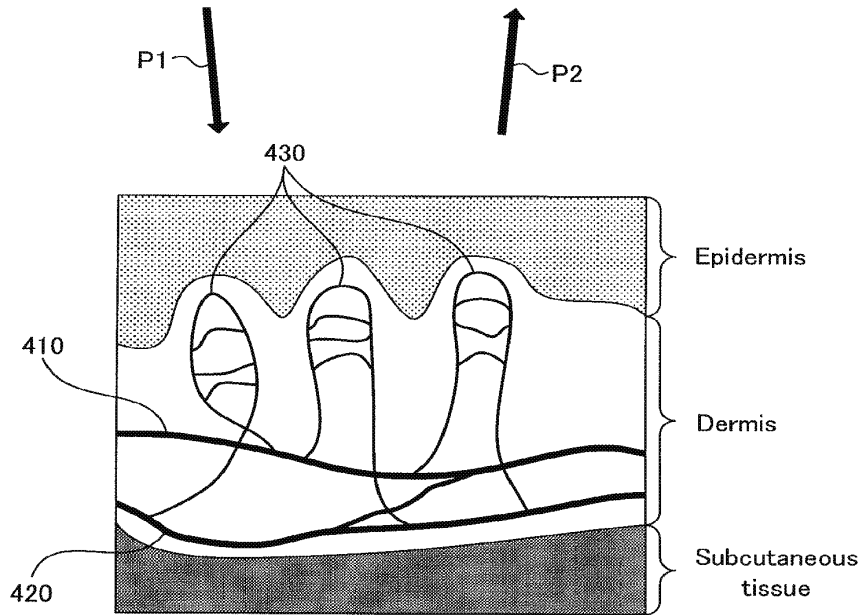

EP 2 277 440 A1

[FIG. 8]

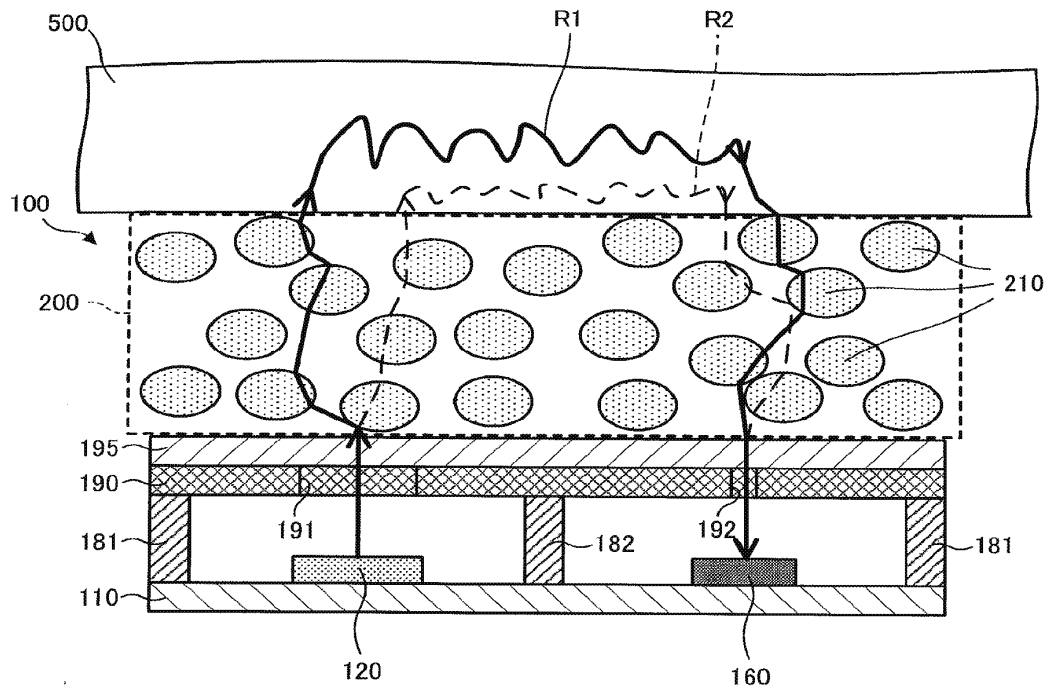

[FIG. 9]

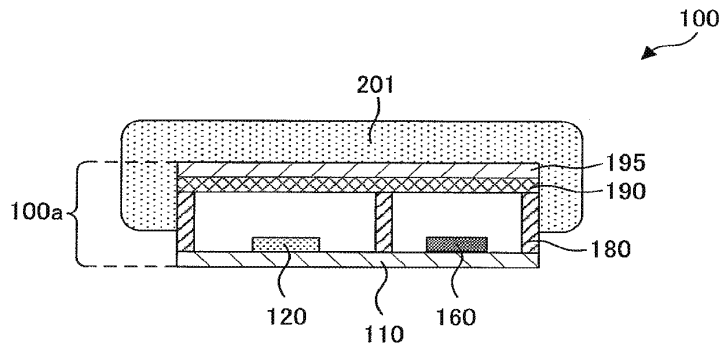

EP 2 277 440 A1

[FIG. 10]

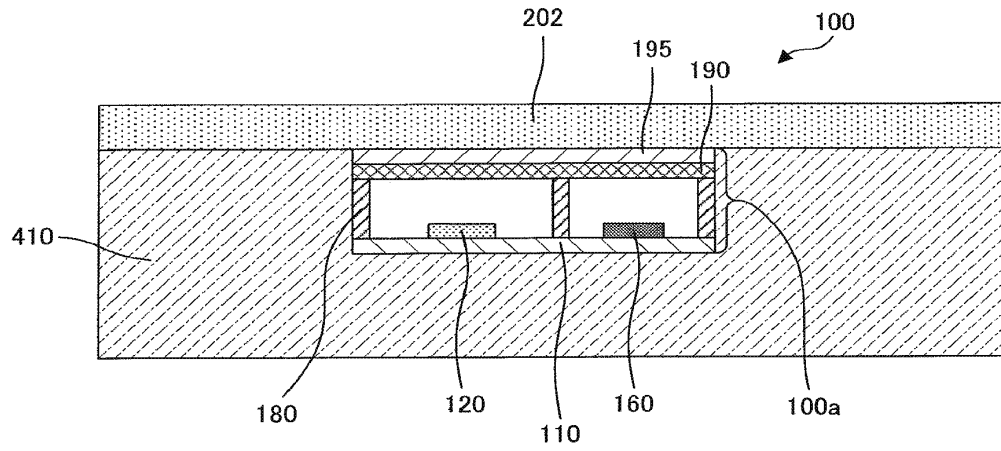

EP 2 277 440 A1

[FIG. 11]

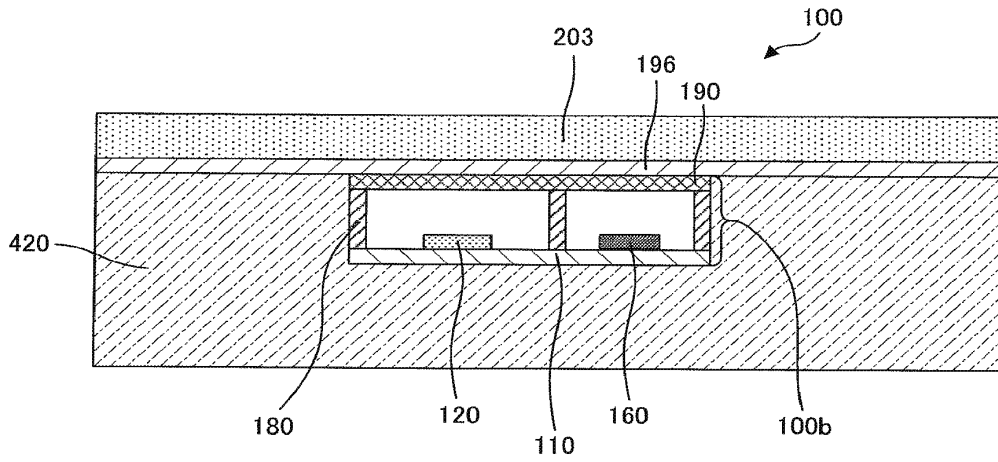

EP 2 277 440 A1

[FIG. 12]

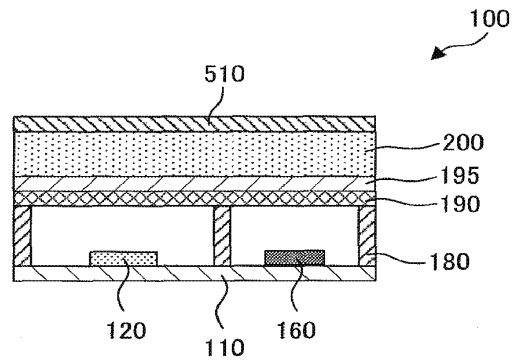

[FIG. 13]

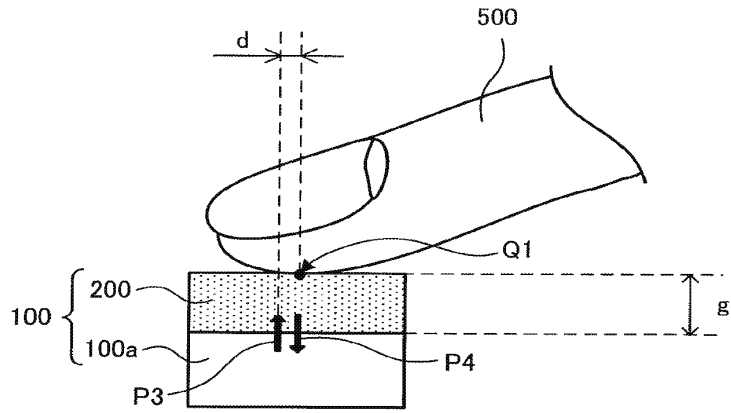

EP 2 277 440 A1

[FIG. 14]

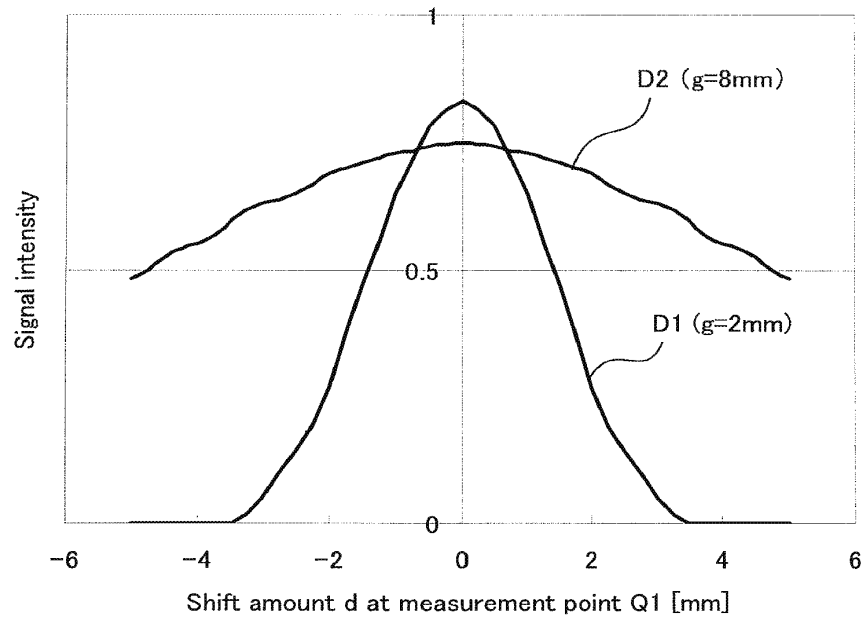

EP 2 277 440 A1

[FIG. 15]

Comparative example : if there is no scatterer

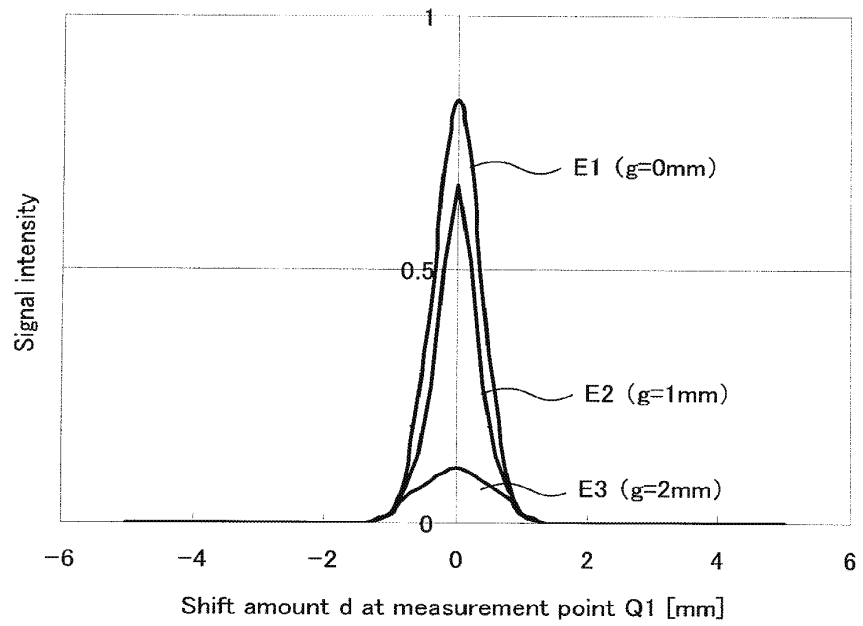

[FIG. 16]

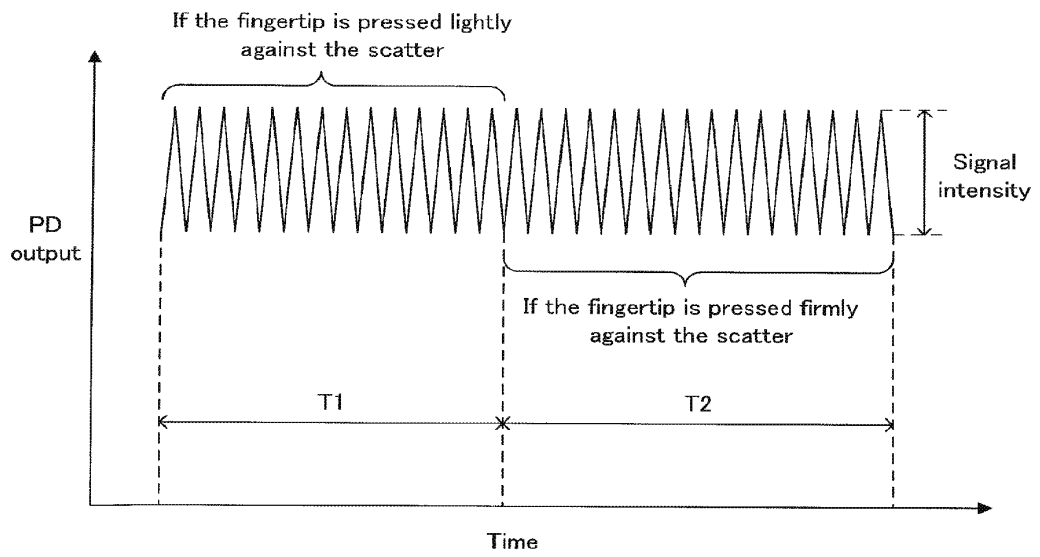

[FIG. 17]

Comparative example: if there is no scatterer

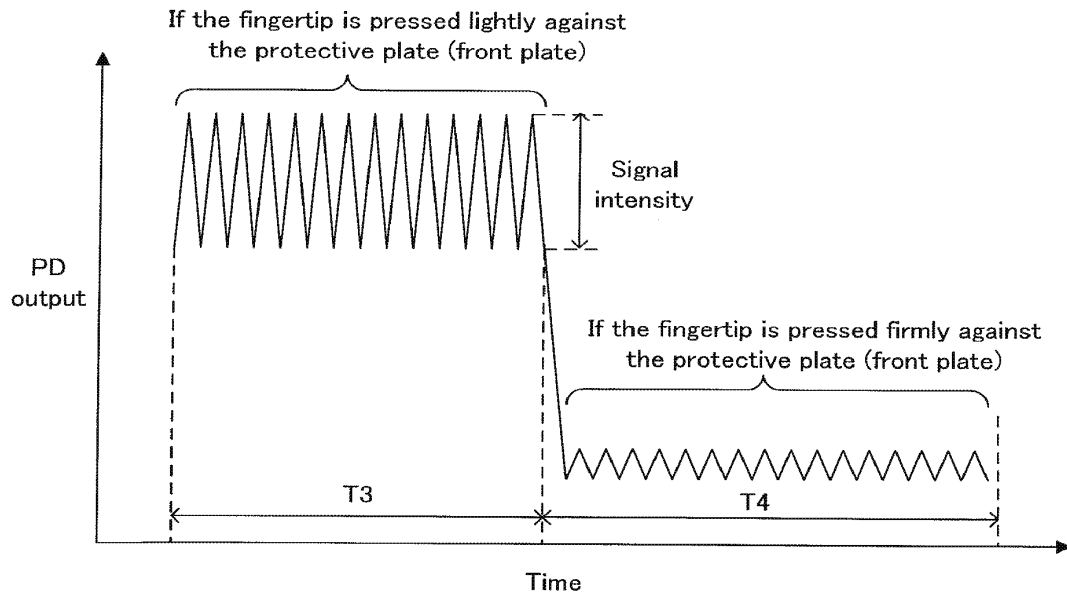

EP 2 277 440 A1

INTERNATIONAL SEARCH REPORT		International application No. PCT/JP2008/058693									
<p>A. CLASSIFICATION OF SUBJECT MATTER A61B5/026(2006.01) i, A61B5/0245(2006.01) i, A61B5/0285(2006.01) i</p> <p>According to International Patent Classification (IPC) or to both national classification and IPC</p>											
<p>B. FIELDS SEARCHED</p> <p>Minimum documentation searched (classification system followed by classification symbols) A61B5/026, A61B5/0245, A61B5/0285</p> <p>Documentation searched other than minimum documentation to the extent that such documents are included in the fields searched Jitsuyo Shinan Koho 1922-1996 Jitsuyo Shinan Toroku Koho 1996-2008 Kokai Jitsuyo Shinan Koho 1971-2008 Toroku Jitsuyo Shinan Koho 1994-2008</p> <p>Electronic data base consulted during the international search (name of data base and, where practicable, search terms used)</p>											
<p>C. DOCUMENTS CONSIDERED TO BE RELEVANT</p> <table border="1" style="width: 100%; border-collapse: collapse;"> <thead> <tr> <th style="width: 10%;">Category*</th> <th style="width: 70%;">Citation of document, with indication, where appropriate, of the relevant passages</th> <th style="width: 20%;">Relevant to claim No.</th> </tr> </thead> <tbody> <tr> <td style="text-align: center;">A</td> <td>JP 2004-229920 A (Nippon Telegraph And Telephone Corp.), 19 August, 2004 (19.08.04), Full text; all drawings & JP 3882756 B2</td> <td style="text-align: center;">1-9</td> </tr> <tr> <td style="text-align: center;">A</td> <td>JP 2006-130208 A (Kyushu University, The University of Tokyo), 25 May, 2006 (25.05.06), Full text; all drawings & WO 2006/051726 A1 & US 2008/97172 A1 & EP 1810613 A1 & JP 4061409 B2</td> <td style="text-align: center;">1-9</td> </tr> </tbody> </table>			Category*	Citation of document, with indication, where appropriate, of the relevant passages	Relevant to claim No.	A	JP 2004-229920 A (Nippon Telegraph And Telephone Corp.), 19 August, 2004 (19.08.04), Full text; all drawings & JP 3882756 B2	1-9	A	JP 2006-130208 A (Kyushu University, The University of Tokyo), 25 May, 2006 (25.05.06), Full text; all drawings & WO 2006/051726 A1 & US 2008/97172 A1 & EP 1810613 A1 & JP 4061409 B2	1-9
Category*	Citation of document, with indication, where appropriate, of the relevant passages	Relevant to claim No.									
A	JP 2004-229920 A (Nippon Telegraph And Telephone Corp.), 19 August, 2004 (19.08.04), Full text; all drawings & JP 3882756 B2	1-9									
A	JP 2006-130208 A (Kyushu University, The University of Tokyo), 25 May, 2006 (25.05.06), Full text; all drawings & WO 2006/051726 A1 & US 2008/97172 A1 & EP 1810613 A1 & JP 4061409 B2	1-9									
<p><input checked="" type="checkbox"/> Further documents are listed in the continuation of Box C. <input type="checkbox"/> See patent family annex.</p>											
<p>* Special categories of cited documents:</p> <table style="width: 100%;"> <tr> <td style="width: 50%;"> "A" document defining the general state of the art which is not considered to be of particular relevance "E" earlier application or patent but published on or after the international filing date "L" document which may throw doubts on priority claim(s) or which is cited to establish the publication date of another citation or other special reason (as specified) "O" document referring to an oral disclosure, use, exhibition or other means "P" document published prior to the international filing date but later than the priority date claimed </td> <td style="width: 50%;"> "T" later document published after the international filing date or priority date and not in conflict with the application but cited to understand the principle or theory underlying the invention "X" document of particular relevance; the claimed invention cannot be considered novel or cannot be considered to involve an inventive step when the document is taken alone "Y" document of particular relevance; the claimed invention cannot be considered to involve an inventive step when the document is combined with one or more other such documents, such combination being obvious to a person skilled in the art "&" document member of the same patent family </td> </tr> </table>			"A" document defining the general state of the art which is not considered to be of particular relevance "E" earlier application or patent but published on or after the international filing date "L" document which may throw doubts on priority claim(s) or which is cited to establish the publication date of another citation or other special reason (as specified) "O" document referring to an oral disclosure, use, exhibition or other means "P" document published prior to the international filing date but later than the priority date claimed	"T" later document published after the international filing date or priority date and not in conflict with the application but cited to understand the principle or theory underlying the invention "X" document of particular relevance; the claimed invention cannot be considered novel or cannot be considered to involve an inventive step when the document is taken alone "Y" document of particular relevance; the claimed invention cannot be considered to involve an inventive step when the document is combined with one or more other such documents, such combination being obvious to a person skilled in the art "&" document member of the same patent family							
"A" document defining the general state of the art which is not considered to be of particular relevance "E" earlier application or patent but published on or after the international filing date "L" document which may throw doubts on priority claim(s) or which is cited to establish the publication date of another citation or other special reason (as specified) "O" document referring to an oral disclosure, use, exhibition or other means "P" document published prior to the international filing date but later than the priority date claimed	"T" later document published after the international filing date or priority date and not in conflict with the application but cited to understand the principle or theory underlying the invention "X" document of particular relevance; the claimed invention cannot be considered novel or cannot be considered to involve an inventive step when the document is taken alone "Y" document of particular relevance; the claimed invention cannot be considered to involve an inventive step when the document is combined with one or more other such documents, such combination being obvious to a person skilled in the art "&" document member of the same patent family										
Date of the actual completion of the international search 28 May, 2008 (28.05.08)		Date of mailing of the international search report 10 June, 2008 (10.06.08)									
Name and mailing address of the ISA/ Japanese Patent Office		Authorized officer									
Facsimile No.		Telephone No.									

Form PCT/ISA/210 (second sheet) (April 2007)

EP 2 277 440 A1

INTERNATIONAL SEARCH REPORT

International application No.

PCT/JP2008/058693

C (Continuation). DOCUMENTS CONSIDERED TO BE RELEVANT		
Category*	Citation of document, with indication, where appropriate, of the relevant passages	Relevant to claim No.
A	WO 2007/97240 A1 (Hamamatsu Photonics Kabushiki Kaisha), 30 August, 2007 (30.08.07), Full text; all drawings & JP 2007-225923 A	1-9

Form PCT/ISA/210 (continuation of second sheet) (April 2007)

EP 2 277 440 A1**REFERENCES CITED IN THE DESCRIPTION**

This list of references cited by the applicant is for the reader's convenience only. It does not form part of the European patent document. Even though great care has been taken in compiling the references, errors or omissions cannot be excluded and the EPO disclaims all liability in this regard.

Patent documents cited in the description

- JP 2004357784 A [0004]
- JP 2004229920 A [0004]
- JP 2006130208 A [0004]
- JP 2001198111 A [0004]

PATENT COOPERATION TREATY

PCT

INTERNATIONAL PRELIMINARY REPORT ON PATENTABILITY
(Chapter I of the Patent Cooperation Treaty)

(PCT Rule 44bis)

Applicant's or agent's file reference MASIMO1007WO2	FOR FURTHER ACTION		See item 4 below
International application No. PCT/US2016/040190	International filing date (<i>day/month/year</i>) 29 June 2016 (29.06.2016)	Priority date (<i>day/month/year</i>) 02 July 2015 (02.07.2015)	
International Patent Classification (8th edition unless older edition indicated) See relevant information in Form PCT/ISA/237			
Applicant MASIMO CORPORATION			

- This international preliminary report on patentability (Chapter I) is issued by the International Bureau on behalf of the International Searching Authority under Rule 44 *bis*.1(a).
- This REPORT consists of a total of 7 sheets, including this cover sheet.

In the attached sheets, any reference to the written opinion of the International Searching Authority should be read as a reference to the international preliminary report on patentability (Chapter I) instead.

- This report contains indications relating to the following items:

<input checked="" type="checkbox"/>	Box No. I	Basis of the report
<input type="checkbox"/>	Box No. II	Priority
<input type="checkbox"/>	Box No. III	Non-establishment of opinion with regard to novelty, inventive step and industrial applicability
<input type="checkbox"/>	Box No. IV	Lack of unity of invention
<input checked="" type="checkbox"/>	Box No. V	Reasoned statement under Article 35(2) with regard to novelty, inventive step or industrial applicability; citations and explanations supporting such statement
<input type="checkbox"/>	Box No. VI	Certain documents cited
<input type="checkbox"/>	Box No. VII	Certain defects in the international application
<input checked="" type="checkbox"/>	Box No. VIII	Certain observations on the international application

- The International Bureau will communicate this report to designated Offices in accordance with Rules 44bis.3(c) and 93bis.1 but not, except where the applicant makes an express request under Article 23(2), before the expiration of 30 months from the priority date (Rule 44bis .2).

The International Bureau of WIPO 34, chemin des Colombettes 1211 Geneva 20, Switzerland Facsimile No. +41 22 338 82 70	Date of issuance of this report 02 January 2018 (02.01.2018)
	Authorized officer Athina Nickitas-Etienne e-mail: pct.team4@wipo.int

Form PCT/IB/373 (January 2004)

APL_MAS_ITC_00557205

PATENT COOPERATION TREATY

From the
INTERNATIONAL SEARCHING AUTHORITY

To: <div style="text-align: center;">see form PCT/ISA/220</div>		<h2 style="margin: 0;">PCT</h2> <p style="margin: 5px 0 0 0;">WRITTEN OPINION OF THE INTERNATIONAL SEARCHING AUTHORITY (PCT Rule 43bis.1)</p>	
Applicant's or agent's file reference see form PCT/ISA/220		FOR FURTHER ACTION See paragraph 2 below	
International application No. PCT/US2016/040190	International filing date (day/month/year) 29.06.2016	Priority date (day/month/year) 02.07.2015	
International Patent Classification (IPC) or both national classification and IPC INV. A61B5/1455 A61B5/00			
Applicant MASIMO CORPORATION			
<p>1. This opinion contains indications relating to the following items:</p> <ul style="list-style-type: none"> <input checked="" type="checkbox"/> Box No. I Basis of the opinion <input type="checkbox"/> Box No. II Priority <input type="checkbox"/> Box No. III Non-establishment of opinion with regard to novelty, inventive step and industrial applicability <input type="checkbox"/> Box No. IV Lack of unity of invention <input checked="" type="checkbox"/> Box No. V Reasoned statement under Rule 43bis.1(a)(i) with regard to novelty, inventive step and industrial applicability; citations and explanations supporting such statement <input type="checkbox"/> Box No. VI Certain documents cited <input type="checkbox"/> Box No. VII Certain defects in the international application <input checked="" type="checkbox"/> Box No. VIII Certain observations on the international application <p>2. FURTHER ACTION</p> <p>If a demand for international preliminary examination is made, this opinion will usually be considered to be a written opinion of the International Preliminary Examining Authority ("IPEA") except that this does not apply where the applicant chooses an Authority other than this one to be the IPEA and the chosen IPEA has notified the International Bureau under Rule 66.1bis(b) that written opinions of this International Searching Authority will not be so considered.</p> <p>If this opinion is, as provided above, considered to be a written opinion of the IPEA, the applicant is invited to submit to the IPEA a written reply together, where appropriate, with amendments, before the expiration of 3 months from the date of mailing of Form PCT/ISA/220 or before the expiration of 22 months from the priority date, whichever expires later.</p> <p>For further options, see Form PCT/ISA/220.</p>			
Name and mailing address of the ISA:  European Patent Office P.B. 5818 Patentlaan 2 NL-2280 HV Rijswijk - Pays Bas Tel. +31 70 340 - 2040 Fax: +31 70 340 - 3016		Date of completion of this opinion see form PCT/ISA/210	Authorized Officer Almeida, Mariana Telephone No. +31 70 340-0

Form PCT/ISA/237 (Cover Sheet) (January 2015)

APL_MAS_ITC_00557206

**WRITTEN OPINION OF THE
INTERNATIONAL SEARCHING AUTHORITY**

International application No.
PCT/US2016/040190

Box No. I Basis of the opinion

1. With regard to the **language**, this opinion has been established on the basis of:
 - the international application in the language in which it was filed.
 - a translation of the international application into , which is the language of a translation furnished for the purposes of international search (Rules 12.3(a) and 23.1 (b)).
2. This opinion has been established taking into account the **rectification of an obvious mistake** authorized by or notified to this Authority under Rule 91 (Rule 43*bis*.1(a))
3. With regard to any **nucleotide and/or amino acid sequence** disclosed in the international application, this opinion has been established on the basis of a sequence listing:
 - a. forming part of the international application as filed:
 - in the form of an Annex C/ST.25 text file.
 - on paper or in the form of an image file.
 - b. furnished together with the international application under PCT Rule 13*ter*.1(a) for the purposes of international search only in the form of an Annex C/ST.25 text file.
 - c. furnished subsequent to the international filing date for the purposes of international search only:
 - in the form of an Annex C/ST.25 text file (Rule 13*ter*.1(a)).
 - on paper or in the form of an image file (Rule 13*ter*.1(b) and Administrative Instructions, Section 713).
4. In addition, in the case that more than one version or copy of a sequence listing has been filed or furnished, the required statements that the information in the subsequent or additional copies is identical to that forming part of the application as filed or does not go beyond the application as filed, as appropriate, were furnished.
5. Additional comments:

**WRITTEN OPINION OF THE
INTERNATIONAL SEARCHING AUTHORITY**

International application No.
PCT/US2016/040190

Box No. V Reasoned statement under Rule 43bis.1(a)(i) with regard to novelty, inventive step or industrial applicability; citations and explanations supporting such statement

1. Statement

Novelty (N)	Yes: Claims	
	No: Claims	<u>1-36</u>
Inventive step (IS)	Yes: Claims	
	No: Claims	<u>1-36</u>
Industrial applicability (IA)	Yes: Claims	<u>1-36</u>
	No: Claims	

2. Citations and explanations

see separate sheet

Box No. VIII Certain observations on the international application

The following observations on the clarity of the claims, description, and drawings or on the question whether the claims are fully supported by the description, are made:

see separate sheet

**WRITTEN OPINION OF THE
INTERNATIONAL SEARCHING
AUTHORITY (SEPARATE SHEET)**

International application No.

PCT/US2016/040190

Re Item V

Reasoned statement with regard to novelty, inventive step or industrial applicability; citations and explanations supporting such statement

Reference is made to the following documents:

1 Independent Claim 1

1.1 The present application does not meet the criteria of Article 33(1) PCT, because the subject-matter of claim 1 is not new in the sense of Article 33(2) PCT. Document D1 discloses:

1.1.1 *"An optical physiological measurement system [Fig. 1] comprising:*

1.1.2 *an emitter which emits light of a wavelength [Column 1, lines 5-8, column 7, lines 16-21; Fig. 2];*

1.1.3 *a diffuser which receives, spreads and emits the spread light [Column 7, lines 21-26; Fig. 2(14)], wherein the emitted spread light is directed at a tissue measurement site of a patient [Fig. 1-3]; and*

1.1.4 *a detector configured to detect the emitted light after attenuation by tissue of the patient [Column 8, lines 34-41], the detector further configured to transmit a signal responsive to the detected light [Column 8, lines 41-43; Fig. 2, 3]."*

1.2 Furthermore, documents D2 [§100, 102; Fig. 1, 3(12, 8)], D3 [§97; Fig. 4], D4 [Column 11, lines 18, 19, 32-34; Fig. 3(6, 9)], D5 [§46; Fig. 8] and D6 [§59; Fig. 2] also disclose the features of claim 1.

1.3 Therefore, claim 1 is not new.

2 Independent Claim 18

2.1 Independent method claim 18 has corresponding features to those of apparatus claim 1.

2.2 Therefore, for the same reasons as for independent claim 1, *mutatis mutandis*, corresponding method claim 18 lacks novelty (Article 33(2) PCT).

**WRITTEN OPINION OF THE
INTERNATIONAL SEARCHING
AUTHORITY (SEPARATE SHEET)**

International application No.

PCT/US2016/040190

3 Dependent Claims

- 3.1 Dependent claims 2-17, 19-36 do not appear to contain any additional features which, in combination with the features of any claim to which they refer, meet the requirements of the PCT with respect to novelty (Article 33(2) PCT):
- 3.1.1 claims 2, 19, 27, 32 (conciseness, see item VIII): concentrator, see D1 [Column 8, lines 43-50; Fig. 2(17)], D2 [§100; Fig. 3(12)], D3 [§97; Fig. 4], D4 [Column 11, lines 18, 19, 32-34; Fig. 3(9)], D5 [§45; Fig. 8(200, 160)], D6 [§59; Fig. 2];
- 3.1.2 claims 3, 20, 28, 33: processor, see D1 [Column 14, lines 10-14], D2 [§87], D3 [§105; Fig. 1], D4 [Fig. 2], D5 [§59; Fig. 5], D6 [§58];
- 3.1.3 claims 4: oxygen saturation, see D1 [Column 1, line 1], D2 [§7], D3 [§77], D4 [Column 1, lines 11-15], D5 [§57], D6 [§62];
- 3.1.4 claims 5, 16, 22, 25: multiple types of glass diffuser and concentrator, see D1 [Column 10, lines 29-34], D2 [§117], D3 [§76], D5 [§49], D6 [§93];
- 3.1.5 claims 6, 23: uniform intensity light profile diffusion, see D1 [Fig. 4], D2 [Fig. 1], D3 [Fig. 3], D4 [Column 11, lines 45-47], D5 [Fig. 14], D6 [§59];
- 3.1.6 claims 7, 9, 13, 24, 29, 30, 34, 35: diffusion into area shape, namely rectangular, square, see D1 [Fig. 2, 3], D2 [Fig. 1, 2], D3 [Fig. 4], D4 [Fig. 1], D5 [Fig. 1, 2];
- 3.1.7 claims 8, 15, 17, 21: filtering, see D1 [Column 6, lines 14-18], D2 [Fig. 27], D3 [§8];
- 3.1.8 claim 10-12, 14: area shape dimensions, see D1 [Fig. 2, 3], D2 [Fig. 1, 2], D3 [Fig. 3], D4 [Fig. 1], D5 [Fig. 1, 2];
- 3.1.9 claim 26: see a conciseness issue, Item VIII; this claim is identical to claim 1, see references therefor above;
- 3.1.10 claim 31, 36: sensor array, see D3 [§95; Fig. 5B].

**WRITTEN OPINION OF THE
INTERNATIONAL SEARCHING
AUTHORITY (SEPARATE SHEET)**

International application No.

PCT/US2016/040190

Re Item VIII

Certain observations on the international application

- 1 Although claims 1, 26 and 32 have been drafted as separate independent claims, they appear to relate effectively to the same subject-matter and to differ from each other only slightly in respect of the terminology used for the features of that subject-matter. Namely, claims 1 and 26 comprise the same subject-matter, and claim 32 comprises the same subject-matter as dependent claim 2. The aforementioned claims therefore lack conciseness and as such do not meet the requirements of Article 6 PCT.

Electronic Patent Application Fee Transmittal				
Application Number:	15195199			
Filing Date:	28-Jun-2016			
Title of Invention:	ADVANCED PULSE OXIMETRY SENSOR			
First Named Inventor/Applicant Name:	Ammar Al-Ali			
Filer:	Aaron Samuel Johnson/Daniel Escaejda			
Attorney Docket Number:	MAS.1007A			
Filed as Large Entity				
Filing Fees for Utility under 35 USC 111(a)				
Description	Fee Code	Quantity	Amount	Sub-Total in USD(\$)
Basic Filing:				
Pages:				
Claims:				
Miscellaneous-Filing:				
Petition:				
Patent-Appeals-and-Interference:				
Post-Allowance-and-Post-Issuance:				
Extension-of-Time:				

Description	Fee Code	Quantity	Amount	Sub-Total in USD(\$)
Miscellaneous:				
SUBMISSION- INFORMATION DISCLOSURE STMT	1806	1	240	240
Total in USD (\$)				240

Electronic Acknowledgement Receipt	
EFS ID:	34236649
Application Number:	15195199
International Application Number:	
Confirmation Number:	3453
Title of Invention:	ADVANCED PULSE OXIMETRY SENSOR
First Named Inventor/Applicant Name:	Ammar Al-Ali
Customer Number:	64735
Filer:	Aaron Samuel Johnson/Daniel Escaejda
Filer Authorized By:	Aaron Samuel Johnson
Attorney Docket Number:	MAS.1007A
Receipt Date:	07-NOV-2018
Filing Date:	28-JUN-2016
Time Stamp:	13:33:50
Application Type:	Utility under 35 USC 111(a)

Payment information:

Submitted with Payment	yes
Payment Type	CARD
Payment was successfully received in RAM	\$240
RAM confirmation Number	110718INTEFSW13353100
Deposit Account	
Authorized User	
The Director of the USPTO is hereby authorized to charge indicated fees and credit any overpayment as follows:	

File Listing:					
Document Number	Document Description	File Name	File Size(Bytes)/ Message Digest	Multi Part /.zip	Pages (if appl.)
1		IDS_MAS1007A.pdf	46677 abd2ac5f8014f300c2b1a7c4df6264e87a6a55c	yes	2
Multipart Description/PDF files in .zip description					
	Document Description		Start	End	
	Transmittal Letter		1	1	
	Information Disclosure Statement (IDS) Form (SB08)		2	2	
Warnings:					
Information:					
2	Foreign Reference	EP0781527A1.pdf	943834 2bc63782933471d844ced2a109b6b6ddc6b7940e7	no	16
Warnings:					
Information:					
3	Foreign Reference	EP2277440A1.pdf	783929 03003aad7e2d1a06f90e4b6ab1da014920eb44cd	no	32
Warnings:					
Information:					
4	Non Patent Literature	WrittenOpinion_PCTUS2016040190.pdf	220849 4ecb02f5391925cfear18b8e0dd0cc763c2d914b	no	7
Warnings:					
Information:					
5	Fee Worksheet (SB06)	fee-info.pdf	30551 092b75b0f4403a08ea80969c08b3a13203ecb3c	no	2
Warnings:					
Information:					

Total Files Size (in bytes):

2025840

This Acknowledgement Receipt evidences receipt on the noted date by the USPTO of the indicated documents, characterized by the applicant, and including page counts, where applicable. It serves as evidence of receipt similar to a Post Card, as described in MPEP 503.

New Applications Under 35 U.S.C. 111

If a new application is being filed and the application includes the necessary components for a filing date (see 37 CFR 1.53(b)-(d) and MPEP 506), a Filing Receipt (37 CFR 1.54) will be issued in due course and the date shown on this Acknowledgement Receipt will establish the filing date of the application.

National Stage of an International Application under 35 U.S.C. 371

If a timely submission to enter the national stage of an international application is compliant with the conditions of 35 U.S.C. 371 and other applicable requirements a Form PCT/DO/EO/903 indicating acceptance of the application as a national stage submission under 35 U.S.C. 371 will be issued in addition to the Filing Receipt, in due course.

New International Application Filed with the USPTO as a Receiving Office

If a new international application is being filed and the international application includes the necessary components for an international filing date (see PCT Article 11 and MPEP 1810), a Notification of the International Application Number and of the International Filing Date (Form PCT/RO/105) will be issued in due course, subject to prescriptions concerning national security, and the date shown on this Acknowledgement Receipt will establish the international filing date of the application.

Docket No.: MAS.1007A

Customer No. 64735

INFORMATION DISCLOSURE STATEMENT

First Inventor	:	Ammar Al-Ali
App. No.	:	15/195199
Filed	:	June 28, 2016
For	:	ADVANCED PULSE OXIMETRY SENSOR
Examiner	:	Fardanesh, Marjan
Art Unit	:	3735
Conf. No.	:	3453

Commissioner for Patents
P.O. Box 1450
Alexandria, VA 22313-1450

References and Listing

Pursuant to 37 CFR 1.56, an Information Disclosure Statement listing references is provided herewith. Copies of any listed foreign and non-patent literature references are being submitted.

No Disclaimers

To the extent that anything in the Information Disclosure Statement or the listed references could be construed as a disclaimer of any subject matter supported by the present application, Applicant hereby rescinds and retracts such disclaimer.

Timing of Disclosure

This Information Disclosure Statement is being filed after receipt of a First Office Action, but before the mailing date of a Final Action and before the mailing date of a Notice of Allowance.

This Statement is accompanied by the fees set forth in 37 CFR 1.17(p). The Commissioner is hereby authorized to charge any additional fees which may be required or to credit any overpayment to Account No. 11-1410.

Respectfully submitted,
KNOBBE, MARTENS, OLSON & BEAR, LLP

Dated: November 7, 2018

By: /Aaron S. Johnson/
Aaron S. Johnson
Registration No. 74,164
Registered Practitioner
Customer No. 64735
(949) 760-0404

29381983

APL_MAS_ITC_00557217

PTO/SB/08 Equivalent

INFORMATION DISCLOSURE STATEMENT BY APPLICANT	Application No.	15/195199	
	Filing Date	June 28, 2016	
	First Named Inventor	Ammar Al-Ali	
	Art Unit	3735	
<i>(Multiple sheets used when necessary)</i>		Examiner	Fardanesh, Marjan
SHEET 1 OF 4		Attorney Docket No.	MAS.1007A

U.S. PATENT DOCUMENTS					
Examiner Initials	Cite No.	Document Number <i>Number - Kind Code (if known)</i> Example: 1,234,567 B1	Publication Date MM-DD-YYYY	Name	Pages, Columns, Lines Where Relevant Passages or Relevant Figures Appear
	1	7,519,327	4/14/2009	White	
	2	7,601,123	10/13/2009	Tweed, et al.	
	3	7,726,209	6/1/2010	Ruotoistenmäki	
	4	7,862,523	1/4/2011	Ruotoistenmaki	
	5	8,289,130	10/16/2012	Nakajima et al.	
	6	8,364,389	1/29/2013	Dorogusker et al.	
	7	8,615,290	12/24/2013	Lin et al.	
	8	8,655,004	2/18/2014	Prest et al.	
	9	8,760,517	6/24/2014	Sarwar et al.	
	10	9,072,437	7/7/2015	Paalasmaa	
	11	9,081,889	7/14/2015	Ingrassia, Jr. et al.	
	12	9,210,566	12/8/2015	Ziemianska et al.	
	13	9,311,382	4/12/2016	Varoglu et al.	
	14	9,357,665	5/31/2016	Myers et al.	
	15	9,489,081	11/8/2016	Anzures et al.	
	16	9,497,534	11/15/2016	Prest et al.	
	17	9,526,430	12/27/2016	Srinivas et al.	
	18	9,553,625	1/24/2017	Hatanaka et al.	
	19	9,593,969	3/14/2017	King	
	20	9,651,405	5/16/2017	Gowreesunker et al.	
	21	9,668,676	6/6/2017	Culbert	
	22	9,699,546	7/4/2017	Qian et al.	
	23	9,716,937	7/25/2017	Qian et al.	
	24	9,723,997	8/8/2017	Lamego	
	25	9,781,984	10/10/2017	Baranski et al.	
	26	9,838,775	12/5/2017	Qian et al.	
	27	9,848,823	12/26/2017	Raghuram et al.	
	28	9,866,671	1/9/2018	Thompson et al.	
	29	9,867,575	1/16/2018	Maani et al.	

Examiner Signature	Date Considered
<p>*Examiner: Initial if reference considered, whether or not citation is in conformance with MPEP 609. Draw line through citation if not in conformance and not considered. Include copy of this form with next communication to applicant.</p>	

T¹ - Place a check mark in this area when an English language Translation is attached.

APL_MAS_ITC_00557218

PTO/SB/08 Equivalent

INFORMATION DISCLOSURE STATEMENT BY APPLICANT	Application No.	15/195199	
	Filing Date	June 28, 2016	
	First Named Inventor	Ammar Al-Ali	
	Art Unit	3735	
<i>(Multiple sheets used when necessary)</i>		Examiner	Fardanesh, Marjan
SHEET 2 OF 4		Attorney Docket No.	MAS.1007A

U.S. PATENT DOCUMENTS					
Examiner Initials	Cite No.	Document Number <i>Number - Kind Code (if known)</i> Example: 1,234,567 B1	Publication Date MM-DD-YYYY	Name	Pages, Columns, Lines Where Relevant Passages or Relevant Figures Appear
	30	9,898,049	2/20/2018	Myers et al.	
	31	9,918,646	3/20/2018	Singh Alvarado et al.	
	32	9,952,095	4/24/2018	Hotelling et al.	
	33	10,039,080	7/31/2018	Miller et al.	
	34	10,055,121	8/21/2018	Chaudhri et al.	
	35	10,066,970	9/4/2018	Gowreesunker et al.	
	36	10,076,257	9/18/2018	Lin et al.	
	37	10,078,052	9/18/2018	Ness et al.	
	38	2014/0171146	6/19/2014	Ma et al.	
	39	2015/0173671	6/25/2015	Paalasmaa et al.	
	40	2015/0255001	9/10/2015	Haughav et al.	
	41	2015/0281424	10/1/2015	Vock et al.	
	42	2015/0318100	11/5/2015	Rothkopf et al.	
	43	2016/0019360	1/21/2016	PAHWA et al.	
	44	2016/0023245	1/28/2016	Zadesky et al.	
	45	2016/0038045	2/11/2016	Shapiro	
	46	2016/0051157	2/25/2016	Waydo	
	47	2016/0051158	2/25/2016	Silva	
	48	2016/0058302	3/3/2016	Raghuram et al.	
	49	2016/0058309	3/3/2016	Han	
	50	2016/0058312	3/3/2016	Han et al.	
	51	2016/0058356	3/3/2016	RAGHURAM et al.	
	52	2016/0058370	3/3/2016	RAGHURAM et al.	
	53	2016/0071392	3/10/2016	Hankey et al.	
	54	2016/0154950	6/2/2016	NAKAJIMA et al.	
	55	2016/0157780	6/9/2016	RIMMINEN et al.	
	56	2016/0213309	7/28/2016	SANNHOLM et al.	
	57	2016/0256058	9/8/2016	Pham et al.	
	58	2016/0256082	9/8/2016	Ely et al.	

Examiner Signature	Date Considered
<p>*Examiner: Initial if reference considered, whether or not citation is in conformance with MPEP 609. Draw line through citation if not in conformance and not considered. Include copy of this form with next communication to applicant.</p>	

T¹ - Place a check mark in this area when an English language Translation is attached.

PTO/SB/08 Equivalent

INFORMATION DISCLOSURE STATEMENT BY APPLICANT	Application No.	15/195199	
	Filing Date	June 28, 2016	
	First Named Inventor	Ammar Al-Ali	
	Art Unit	3735	
<i>(Multiple sheets used when necessary)</i>		Examiner	Fardanesh, Marjan
SHEET 3 OF 4		Attorney Docket No.	MAS.1007A

U.S. PATENT DOCUMENTS					
Examiner Initials	Cite No.	Document Number <i>Number - Kind Code (if known)</i> Example: 1,234,567 B1	Publication Date MM-DD-YYYY	Name	Pages, Columns, Lines Where Relevant Passages or Relevant Figures Appear
	59	2016/0267238	9/15/2016	Nag	
	60	2016/0287181	10/6/2016	Han et al.	
	61	2016/0296173	10/13/2016	Culbert	
	62	2016/0296174	10/13/2016	Isikman et al.	
	63	2016/0310027	10/27/2016	Han	
	64	2016/0378069	12/29/2016	Rothkopf	
	65	2016/0378071	12/29/2016	Rothkopf	
	66	2017/0007183	1/12/2017	Dusan et al.	
	67	2017/0010858	1/12/2017	Prest et al.	
	68	2017/0074897	3/16/2017	Mermel et al.	
	69	2017/0084133	3/23/2017	Cardinali et al.	
	70	2017/0086689	3/30/2017	Shui et al.	
	71	2017/0086742	3/30/2017	Harrison-Noonan et al.	
	72	2017/0086743	3/30/2017	Bushnell et al.	
	73	2017/0094450	3/30/2017	Tu et al.	
	74	2017/0164884	6/15/2017	Culbert et al.	
	75	2017/0248446	8/31/2017	Gowreesunker et al.	
	76	2017/0273619	9/28/2017	Alvarado et al.	
	77	2017/0281024	10/5/2017	Narasimhan et al.	
	78	2017/0293727	10/12/2017	Klaassen et al.	
	79	2017/0325698	11/16/2017	Allec et al.	
	80	2017/0325744	11/16/2017	Allec et al.	
	81	2017/0340209	11/30/2017	Klaassen et al.	
	82	2017/0340219	11/30/2017	Sullivan et al.	
	83	2017/0347885	12/7/2017	Tan et al.	
	84	2017/0354332	12/14/2017	Lamego	
	85	2017/0354795	12/14/2017	BLAHNIK et al.	
	86	2017/0358239	12/14/2017	Arney et al.	
	87	2017/0358240	12/14/2017	Blahnik et al.	

Examiner Signature	Date Considered
<p>*Examiner: Initial if reference considered, whether or not citation is in conformance with MPEP 609. Draw line through citation if not in conformance and not considered. Include copy of this form with next communication to applicant.</p>	

T¹ - Place a check mark in this area when an English language Translation is attached.

PTO/SB/08 Equivalent

INFORMATION DISCLOSURE STATEMENT BY APPLICANT	Application No.	15/195199	
	Filing Date	June 28, 2016	
	First Named Inventor	Ammar Al-Ali	
	Art Unit	3735	
<i>(Multiple sheets used when necessary)</i>		Examiner	Fardanesh, Marjan
SHEET 4 OF 4		Attorney Docket No.	MAS.1007A

U.S. PATENT DOCUMENTS					
Examiner Initials	Cite No.	Document Number <i>Number - Kind Code (if known)</i> Example: 1,234,567 B1	Publication Date MM-DD-YYYY	Name	Pages, Columns, Lines Where Relevant Passages or Relevant Figures Appear
	88	2017/0358242	12/14/2017	Thompson et al.	
	89	2017/0360306	12/14/2017	Narasimhan et al.	
	90	2017/0366657	12/21/2017	Thompson et al.	
	91	2018/0014781	1/18/2018	Clavelle et al.	
	92	2018/0025287	1/25/2018	Mathew et al.	
	93	2018/0042556	2/15/2018	SHAHPARNIA et al.	
	94	2018/0049694	2/22/2018	Singh Alvarado et al.	
	95	2018/0050235	2/22/2018	Tan et al.	
	96	2018/0055375	3/1/2018	MARTINEZ et al.	
	97	2018/0055439	3/1/2018	Pham et al.	
	98	2018/0056129	1/1/2018	NARASIMHA RAO et al.	
	99	2018/0078151	3/22/2018	ALLEC et al.	
	100	2018/0078182	3/22/2018	CHEN et al.	
	101	2018/0110469	4/26/2018	MAANI et al.	
	102	2018/0153418	6/7/2018	SULLIVAN et al.	
	103	2018/0164853	6/14/2018	Myers et al.	
	104	2018/0196514	7/12/2018	ALLEC et al.	
	105	2018/0228414	8/16/2018	SHAO et al.	
	106	2018/0238734	8/23/2018	Hotelling et al.	
	107	2018/0279956	10/4/2018	WAYDO et al.	

FOREIGN PATENT DOCUMENTS						
Examiner Initials	Cite No.	Foreign Patent Document <i>Country Code-Number-Kind Code</i> Example: JP 1234567 A1	Publication Date MM-DD-YYYY	Name	Pages, Columns, Lines Where Relevant Passages or Relevant Figures Appear	T ¹

NON PATENT LITERATURE DOCUMENTS			
Examiner Initials	Cite No.	Include name of the author (in CAPITAL LETTERS), title of the article (when appropriate), title of the item (book, magazine, journal, serial, symposium, catalog, etc.), date, page(s), volume-issue number(s), publisher, city and/or country where published.	T ¹

29627918

Examiner Signature	Date Considered
<p>*Examiner: Initial if reference considered, whether or not citation is in conformance with MPEP 609. Draw line through citation if not in conformance and not considered. Include copy of this form with next communication to applicant.</p>	

T¹ - Place a check mark in this area when an English language Translation is attached.

APL_MAS_ITC_00557221

Docket No.: MAS.1007A

Customer No. 64735

INFORMATION DISCLOSURE STATEMENT

First Inventor	:	Ammar Al-Ali
App. No.	:	15/195199
Filed	:	June 28, 2016
For	:	ADVANCED PULSE OXIMETRY SENSOR
Examiner	:	Fardanesh, Marjan
Art Unit	:	3735
Conf. No.	:	3453

Commissioner for Patents
P.O. Box 1450
Alexandria, VA 22313-1450

References and Listing

Pursuant to 37 CFR 1.56, an Information Disclosure Statement listing references is provided herewith. Copies of any listed foreign and non-patent literature references are being submitted.

No Disclaimers

To the extent that anything in the Information Disclosure Statement or the listed references could be construed as a disclaimer of any subject matter supported by the present application, Applicant hereby rescinds and retracts such disclaimer.

Timing of Disclosure

This Information Disclosure Statement is being filed after receipt of a First Office Action, but before the mailing date of a Final Action and before the mailing date of a Notice of Allowance.

This Statement is accompanied by the fees set forth in 37 CFR 1.17(p). The Commissioner is hereby authorized to charge any additional fees which may be required or to credit any overpayment to Account No. 11-1410.

Respectfully submitted,
KNOBBE, MARTENS, OLSON & BEAR, LLP

Dated: December 20, 2018

By: /Aaron S. Johnson/
Aaron S. Johnson
Registration No. 74,164
Registered Practitioner
Customer No. 64735
(949) 760-0404

29628289

APL_MAS_ITC_00557222

Electronic Patent Application Fee Transmittal				
Application Number:	15195199			
Filing Date:	28-Jun-2016			
Title of Invention:	ADVANCED PULSE OXIMETRY SENSOR			
First Named Inventor/Applicant Name:	Ammar Al-Ali			
Filer:	Aaron Samuel Johnson/Daniel Escajeda			
Attorney Docket Number:	MAS.1007A			
Filed as Large Entity				
Filing Fees for Utility under 35 USC 111(a)				
Description	Fee Code	Quantity	Amount	Sub-Total in USD(\$)
Basic Filing:				
Pages:				
Claims:				
Miscellaneous-Filing:				
Petition:				
Patent-Appeals-and-Interference:				
Post-Allowance-and-Post-Issuance:				
Extension-of-Time:				

Description	Fee Code	Quantity	Amount	Sub-Total in USD(\$)
Miscellaneous:				
SUBMISSION- INFORMATION DISCLOSURE STMT	1806	1	240	240
Total in USD (\$)				240

Electronic Acknowledgement Receipt	
EFS ID:	34653482
Application Number:	15195199
International Application Number:	
Confirmation Number:	3453
Title of Invention:	ADVANCED PULSE OXIMETRY SENSOR
First Named Inventor/Applicant Name:	Ammar Al-Ali
Customer Number:	64735
Filer:	Aaron Samuel Johnson/Daniel Escajeda
Filer Authorized By:	Aaron Samuel Johnson
Attorney Docket Number:	MAS.1007A
Receipt Date:	20-DEC-2018
Filing Date:	28-JUN-2016
Time Stamp:	13:23:28
Application Type:	Utility under 35 USC 111(a)

Payment information:

Submitted with Payment	yes
Payment Type	CARD
Payment was successfully received in RAM	\$240
RAM confirmation Number	122018INTEFSW13240600
Deposit Account	
Authorized User	
The Director of the USPTO is hereby authorized to charge indicated fees and credit any overpayment as follows:	

File Listing:					
Document Number	Document Description	File Name	File Size(Bytes)/ Message Digest	Multi Part /.zip	Pages (if appl.)
1		IDS_MAS1007A.pdf	73060 a45f4d73dbc28a1bc07aac8cb79df281dd9d13f7	yes	5
Multipart Description/PDF files in .zip description					
	Document Description		Start	End	
	Information Disclosure Statement (IDS) Form (SB08)		2	5	
	Transmittal Letter		1	1	
Warnings:					
Information:					
2	Fee Worksheet (SB06)	fee-info.pdf	30552 a057bc379365437a51dc315576ec1a9ca5bd3c6a	no	2
Warnings:					
Information:					
Total Files Size (in bytes):			103612		
<p>This Acknowledgement Receipt evidences receipt on the noted date by the USPTO of the indicated documents, characterized by the applicant, and including page counts, where applicable. It serves as evidence of receipt similar to a Post Card, as described in MPEP 503.</p> <p><u>New Applications Under 35 U.S.C. 111</u> If a new application is being filed and the application includes the necessary components for a filing date (see 37 CFR 1.53(b)-(d) and MPEP 506), a Filing Receipt (37 CFR 1.54) will be issued in due course and the date shown on this Acknowledgement Receipt will establish the filing date of the application.</p> <p><u>National Stage of an International Application under 35 U.S.C. 371</u> If a timely submission to enter the national stage of an international application is compliant with the conditions of 35 U.S.C. 371 and other applicable requirements a Form PCT/DO/EO/903 indicating acceptance of the application as a national stage submission under 35 U.S.C. 371 will be issued in addition to the Filing Receipt, in due course.</p> <p><u>New International Application Filed with the USPTO as a Receiving Office</u> If a new international application is being filed and the international application includes the necessary components for an international filing date (see PCT Article 11 and MPEP 1810), a Notification of the International Application Number and of the International Filing Date (Form PCT/RO/105) will be issued in due course, subject to prescriptions concerning national security, and the date shown on this Acknowledgement Receipt will establish the international filing date of the application.</p>					



UNITED STATES PATENT AND TRADEMARK OFFICE

UNITED STATES DEPARTMENT OF COMMERCE
 United States Patent and Trademark Office
 Address: COMMISSIONER FOR PATENTS
 P.O. Box 1450
 Alexandria, Virginia 22313-1450
 www.uspto.gov

APPLICATION NO.	FILING DATE	FIRST NAMED INVENTOR	ATTORNEY DOCKET NO.	CONFIRMATION NO.
15/195,199	06/28/2016	Ammar Al-Ali	MAS.1007A	3453
64735	7590	03/29/2019	EXAMINER FARDANESH, MARJAN	
KNOBBE, MARTENS, OLSON & BEAR, LLP MASIMO CORPORATION (MASIMO) 2040 MAIN STREET FOURTEENTH FLOOR IRVINE, CA 92614			ART UNIT PAPER NUMBER 3791	
			NOTIFICATION DATE DELIVERY MODE 03/29/2019 ELECTRONIC	

Please find below and/or attached an Office communication concerning this application or proceeding.

The time period for reply, if any, is set in the attached communication.

Notice of the Office communication was sent electronically on above-indicated "Notification Date" to the following e-mail address(es):

efiling@knobbe.com
 jayna.cartee@knobbe.com

Office Action Summary	Application No. 15/195,199	Applicant(s) Al-Ali et al.	
	Examiner MARJAN FARDANESH	Art Unit 3791	AIA (FITF) Status Yes

-- The MAILING DATE of this communication appears on the cover sheet with the correspondence address --

Period for Reply

A SHORTENED STATUTORY PERIOD FOR REPLY IS SET TO EXPIRE 3 MONTHS FROM THE MAILING DATE OF THIS COMMUNICATION.

- Extensions of time may be available under the provisions of 37 CFR 1.136(a). In no event, however, may a reply be timely filed after SIX (6) MONTHS from the mailing date of this communication.
- If NO period for reply is specified above, the maximum statutory period will apply and will expire SIX (6) MONTHS from the mailing date of this communication.
- Failure to reply within the set or extended period for reply will, by statute, cause the application to become ABANDONED (35 U.S.C. § 133).

Any reply received by the Office later than three months after the mailing date of this communication, even if timely filed, may reduce any earned patent term adjustment. See 37 CFR 1.704(b).

Status

1) Responsive to communication(s) filed on 11/6/18.
 A declaration(s)/affidavit(s) under **37 CFR 1.130(b)** was/were filed on _____.

2a) This action is **FINAL**. 2b) This action is non-final.

3) An election was made by the applicant in response to a restriction requirement set forth during the interview on _____; the restriction requirement and election have been incorporated into this action.

4) Since this application is in condition for allowance except for formal matters, prosecution as to the merits is closed in accordance with the practice under *Ex parte Quayle*, 1935 C.D. 11, 453 O.G. 213.

Disposition of Claims*

5) Claim(s) 1-7, 16, 18-20, 22-29, 32-33 and 37-48 is/are pending in the application.
5a) Of the above claim(s) _____ is/are withdrawn from consideration.

6) Claim(s) _____ is/are allowed.

7) Claim(s) 1-7, 16, 18-20, 22-29, 32-33 and 37-48 is/are rejected.

8) Claim(s) _____ is/are objected to.

9) Claim(s) _____ are subject to restriction and/or election requirement

* If any claims have been determined allowable, you may be eligible to benefit from the **Patent Prosecution Highway** program at a participating intellectual property office for the corresponding application. For more information, please see http://www.uspto.gov/patents/init_events/pph/index.jsp or send an inquiry to **PPHfeedback@uspto.gov**.

Application Papers

10) The specification is objected to by the Examiner.

11) The drawing(s) filed on _____ is/are: a) accepted or b) objected to by the Examiner.
Applicant may not request that any objection to the drawing(s) be held in abeyance. See 37 CFR 1.85(a).
Replacement drawing sheet(s) including the correction is required if the drawing(s) is objected to. See 37 CFR 1.121(d).

Priority under 35 U.S.C. § 119

12) Acknowledgment is made of a claim for foreign priority under 35 U.S.C. § 119(a)-(d) or (f).

Certified copies:

a) All b) Some** c) None of the:

1. Certified copies of the priority documents have been received.

2. Certified copies of the priority documents have been received in Application No. _____.

3. Copies of the certified copies of the priority documents have been received in this National Stage application from the International Bureau (PCT Rule 17.2(a)).

** See the attached detailed Office action for a list of the certified copies not received.

Attachment(s)

1) Notice of References Cited (PTO-892)

2) Information Disclosure Statement(s) (PTO/SB/08a and/or PTO/SB/08b)
Paper No(s)/Mail Date 12/20/2018, 11/07/2018,

3) Interview Summary (PTO-413)
Paper No(s)/Mail Date _____

4) Other: _____

U.S. Patent and Trademark Office

PTOL-326 (Rev. 11-13)

Office Action Summary

Part of Paper No./Mail Date 20190219

Application/Control Number: 15/195,199
Art Unit: 3791

Page 2

Notice of Pre-AIA or AIA Status

1. The present application, filed on or after March 16, 2013, is being examined under the first inventor to file provisions of the AIA.

Claim Rejections - 35 USC § 102

2. The following is a quotation of the appropriate paragraphs of 35 U.S.C. 102 that form the basis for the rejections under this section made in this Office action:

A person shall be entitled to a patent unless –

(a)(1) the claimed invention was patented, described in a printed publication, or in public use, on sale or otherwise available to the public before the effective filing date of the claimed invention.

3. Claim(s) 1, 18, 26, 32, 38, 40, 42, 45 is/are rejected under 35 U.S.C. 102(a)(1) as being anticipated by Rosenheimer (USPN 5,497,771).

Regarding claims 1, 18, 26 and 32, Rosenheimer discloses an optical physiological measurement device configured for placement on a patient at a tissue measurement site (figures 4-5), the device comprising: one or more emitters which emit light (photodiodes 10 and 11 figures 4-5); one or more detectors configured to detect the emitted light after attenuation by and reflection from tissue of the patient at the tissue measurement site, the one or more detectors further configured to transmit a signal responsive to the detected light (photodetector 18 figures 4 and 5); and a light block comprising an annular ring located between the emitted light at the tissue measurement site and the one or more detectors, the light block reducing an amount of incident light emitted from the one or more emitters from being detected by the one or more detectors (light block 28 figures 4-5). See Col.4 line 25-Col.5 line 30.

APL_MAS_ITC_00557229

PAGE 270 OF 530

**MASIMO 2057
Apple v. Masimo
IPR2022-01291**