



(19) **United States**

(12) **Patent Application Publication**
Johnson et al.

(10) **Pub. No.: US 2013/0267854 A1**
(43) **Pub. Date: Oct. 10, 2013**

(54) **OPTICAL MONITORING AND COMPUTING DEVICES AND METHODS OF USE**

(57) **ABSTRACT**

(76) Inventors: **Jami Johnson**, Boise, ID (US); **Michelle Sabick**, Boise, ID (US)

The present invention relates to medical devices and, in particular, to optical computing devices configured to monitor cardiac-related conditions. One optical computing device includes a substrate, at least one light source mounted on the substrate and configured to emit electromagnetic radiation that optically interacts with a vasculature and generates an optically interacted signal, a plurality of detectors mounted on the substrate and configured to detect the optically interacted signal, and a stabilizing matrix arranged on the substrate and substantially surrounding the at least one light source and the plurality of detectors. The stabilizing matrix may be configured to absorb vibration and thereby reduce motion artifacts detectable by the plurality of detectors.

(21) Appl. No.: **13/442,551**

(22) Filed: **Apr. 9, 2012**

Publication Classification

(51) **Int. Cl.**
A61B 5/00 (2006.01)

(52) **U.S. Cl.**
CPC **A61B 5/0082** (2013.01)
USPC **600/473; 600/479**

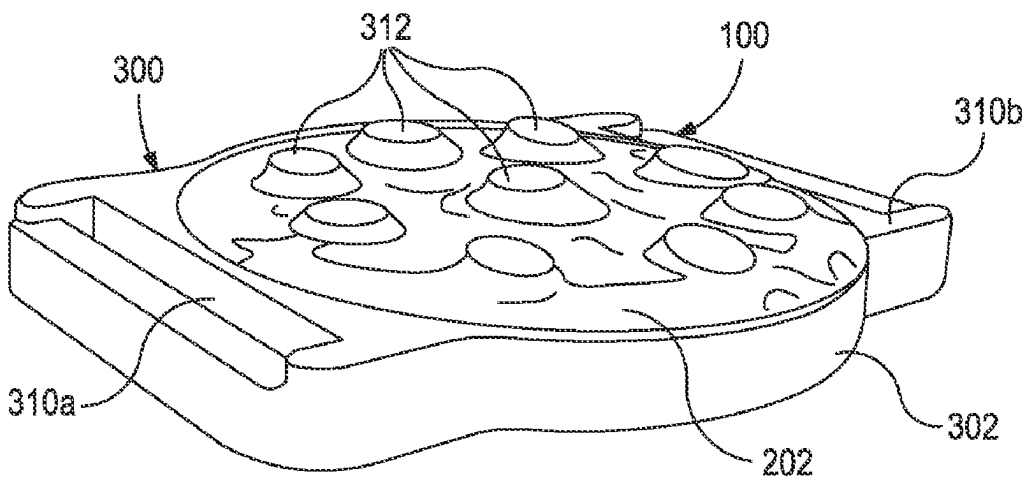

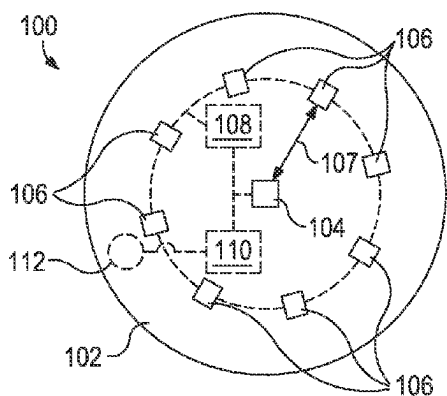

FIG. 1a

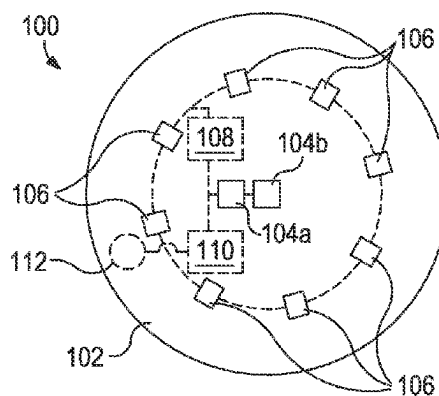

FIG. 1b

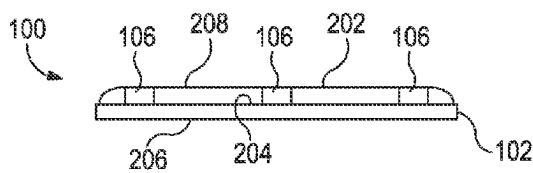

FIG. 2a

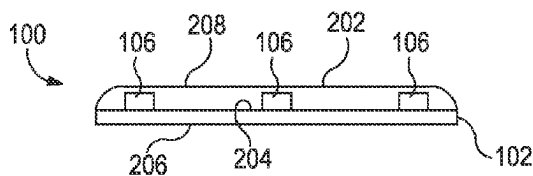

FIG. 2b

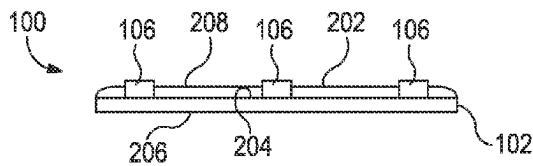

FIG. 2c

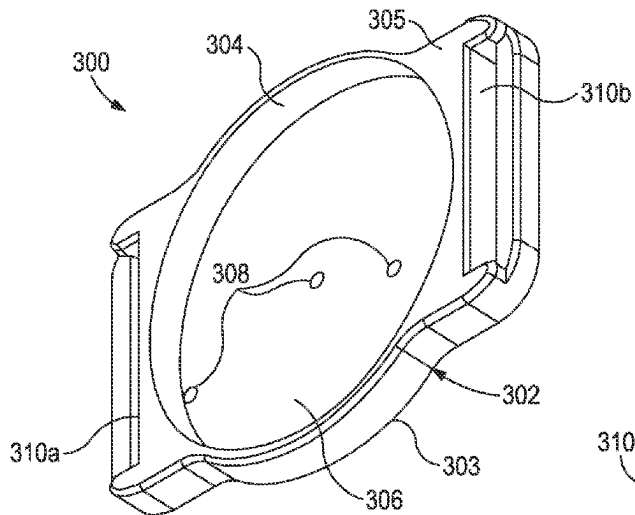

FIG. 3a

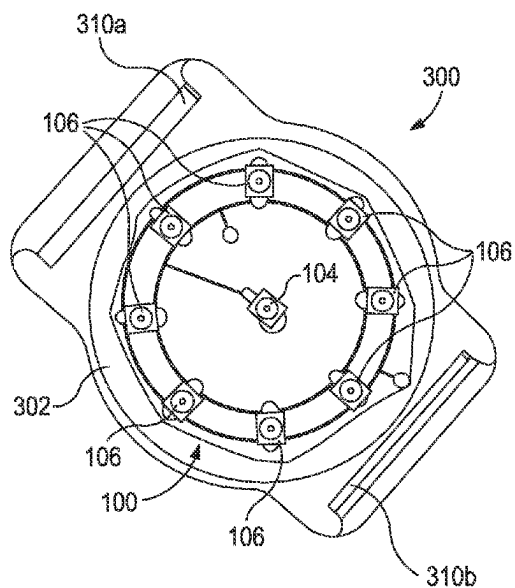

FIG. 3b

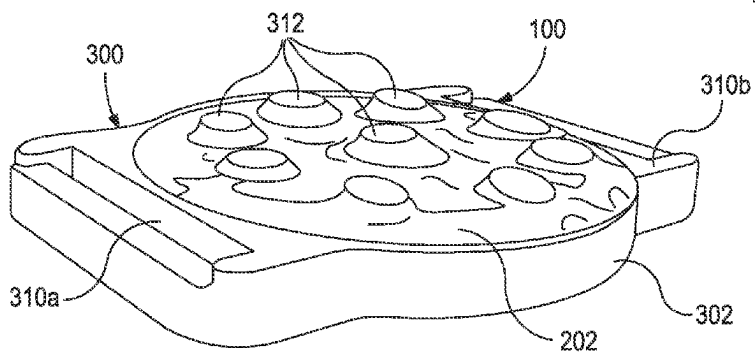

FIG. 3c

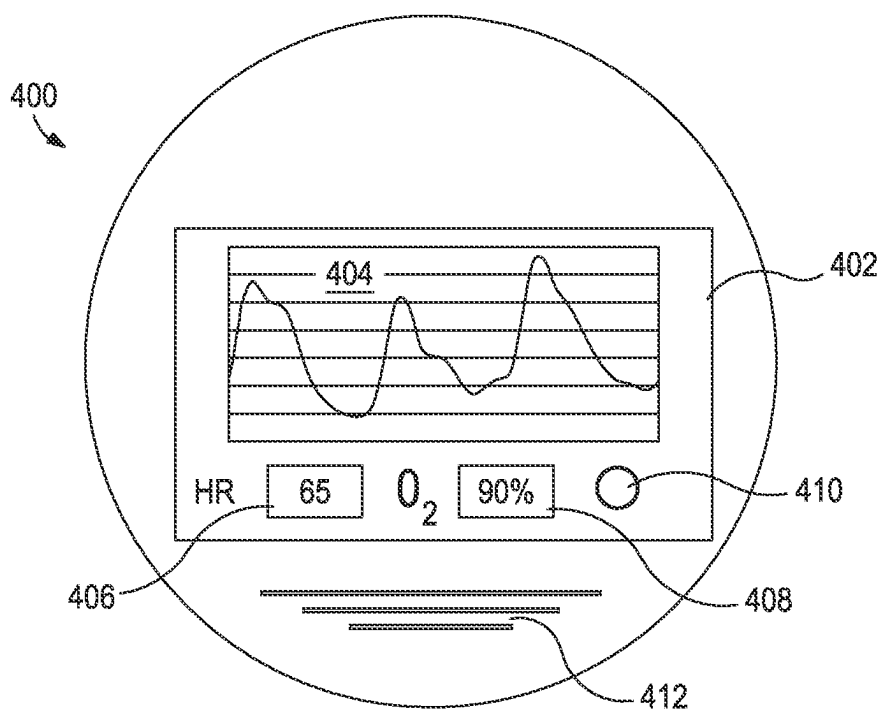

FIG. 4

OPTICAL MONITORING AND COMPUTING DEVICES AND METHODS OF USE

BACKGROUND

[0001] The present invention relates to medical devices and, in particular, to optical computing devices configured to monitor cardiac-related conditions.

[0002] Photoplethysmography (PPG) is a noninvasive and low cost optical technique used for studying skin blood volume pulsations. Blood-pressure waves that are generated by the heart propagate along the skin arteries, locally increasing and decreasing the tissue blood volume with the periodicity of heartbeats. PPG exploits this phenomenon through the use of narrow-band light-emitting diodes (LEDs) in the infrared or near-infrared region. Back scattering of the optical radiation is typically detected in either transmission or reflection configuration by one or more strategically-placed photodetectors. Heart rate, respiratory rate, and tissue blood perfusion, as well as indicators of cardiac disorders and peripheral vascular diseases can be extracted from the analysis of a single PPG trace. Factors such as skin color, volume of adipose tissue, ambient light, sensor location, and movement artifacts have been known to affect the robustness and consistency of PPG signals.

[0003] Of late, there has been a resurgence of interest in using PPG, driven primarily by the demand for low cost, simple, and portable technology for the primary care and community-based clinical settings, and the wide availability of inexpensive and small semiconductor components. PPG technology has been used in a wide range of commercially available medical devices for measuring oxygen saturation, blood pressure and cardiac output, assessing autonomic function, and also detecting peripheral vascular disease. As a result, innovative methods or devices capable of obtaining reliable PPG signals in various locations on the body have the potential to be useful in various clinical applications, as well as for self-monitoring applications.

SUMMARY OF THE INVENTION

[0004] The present invention relates to medical devices and, in particular, to optical computing devices configured to monitor cardiac-related conditions.

[0005] In some aspects of the disclosure, a device is disclosed. The device may include a substrate and at least one light source mounted on the substrate and configured to emit electromagnetic radiation that optically interacts with a vasculature and generates an optically interacted signal. The device may also include a plurality of detectors mounted on the substrate and configured to detect the optically interacted signal, and a stabilizing matrix arranged on the substrate and substantially surrounding the at least one light source and the plurality of detectors. The stabilizing matrix may be configured to absorb vibration and thereby reduce motion artifacts detectable by the plurality of detectors.

[0006] In some aspects, another device may be disclosed. The device may include a housing having a front surface and a back surface, and a substrate having a front side and a back side, where the back side may be removably coupled to the back surface of the housing. The device may also include at least one light source mounted on the front side of the substrate and configured to emit electromagnetic radiation that

mounted on the front side of the substrate and configured to detect the optically interacted signal. The device may further include a stabilizing matrix arranged on the front side of the substrate and substantially surrounding the at least one light source and the plurality of detectors. The stabilizing matrix may be configured to absorb vibration and thereby reduce motion artifacts detectable by the plurality of detectors.

[0007] In some aspects of the disclosure, a method for detecting cardiac-related conditions is disclosed. The method may include emitting electromagnetic radiation through a vasculature using at least one light source mounted on a substrate. The electromagnetic radiation may be configured to optically react with the vasculature and reflect an optically interacted signal. The method may also include detecting the optically interacted signal with a plurality of detectors mounted on the substrate. The plurality of detectors may be configured to generate signal data. The method may further include absorbing vibration and reducing motion artifacts detectable by the plurality of detectors with a stabilizing matrix, where the stabilizing matrix may be arranged on the substrate and substantially surrounding the at least one light source and the plurality of detectors. The method may even further include receiving the signal data with a processing device communicably coupled to the plurality of detectors, and processing the signal data to determine the cardiac-related conditions.

[0008] The features and advantages of the present invention will be readily apparent to those skilled in the art upon a reading of the description of the preferred embodiments that follows.

BRIEF DESCRIPTION OF THE DRAWINGS

[0009] The following figures are included to illustrate certain aspects of the present invention, and should not be viewed as exclusive embodiments. The subject matter disclosed is capable of considerable modifications, alterations, combinations, and equivalents in form and function, as will occur to those skilled in the art and having the benefit of this disclosure.

[0010] FIG. 1a is an exemplary optical computing device, according to one or more embodiments disclosed.

[0011] FIG. 1b is a variation of the exemplary optical computing device of FIG. 1a, according to one or more embodiments disclosed.

[0012] FIGS. 2a, 2b, and 2c are side views of the exemplary optical computing device of FIG. 1, according to one or more embodiments disclosed.

[0013] FIG. 3a is an isometric view of an exemplary housing that may be used to receive and seat an optical computing device, according to one or more embodiments disclosed.

[0014] FIG. 3b illustrates the housing of FIG. 3a with an optical computing device arranged therein, according to one or more embodiments disclosed.

[0015] FIG. 3c illustrates the optical computing device of FIG. 3b having a stabilizing matrix applied thereto, according to one or more embodiments disclosed.

[0016] FIG. 4 illustrates an exemplary interface configured to provide real-time cardiac-related information, according to one or more embodiments.

DETAILED DESCRIPTION

[0017] The present invention relates to medical devices

Explore Litigation Insights

Docket Alarm provides insights to develop a more informed litigation strategy and the peace of mind of knowing you're on top of things.

Real-Time Litigation Alerts



Keep your litigation team up-to-date with **real-time alerts** and advanced team management tools built for the enterprise, all while greatly reducing PACER spend.

Our comprehensive service means we can handle Federal, State, and Administrative courts across the country.

Advanced Docket Research



With over 230 million records, Docket Alarm's cloud-native docket research platform finds what other services can't. Coverage includes Federal, State, plus PTAB, TTAB, ITC and NLRB decisions, all in one place.

Identify arguments that have been successful in the past with full text, pinpoint searching. Link to case law cited within any court document via Fastcase.

Analytics At Your Fingertips



Learn what happened the last time a particular judge, opposing counsel or company faced cases similar to yours.

Advanced out-of-the-box PTAB and TTAB analytics are always at your fingertips.

API

Docket Alarm offers a powerful API (application programming interface) to developers that want to integrate case filings into their apps.

LAW FIRMS

Build custom dashboards for your attorneys and clients with live data direct from the court.

Automate many repetitive legal tasks like conflict checks, document management, and marketing.

FINANCIAL INSTITUTIONS

Litigation and bankruptcy checks for companies and debtors.

E-DISCOVERY AND LEGAL VENDORS

Sync your system to PACER to automate legal marketing.