



US006353443B1

(12) **United States Patent**
Ying

(10) **Patent No.:** **US 6,353,443 B1**
(45) **Date of Patent:** ***Mar. 5, 2002**

(54) **MINIATURE PRINTED SPIRAL ANTENNA FOR MOBILE TERMINALS**

(75) Inventor: **Zhinong Ying, Lund (SE)**

(73) Assignee: **Telefonaktiebolaget LM Ericsson (publ), Stockholm (SE)**

(*) Notice: Subject to any disclaimer, the term of this patent is extended or adjusted under 35 U.S.C. 154(b) by 0 days.

This patent is subject to a terminal disclaimer.

(21) Appl. No.: **09/112,366**

(22) Filed: **Jul. 9, 1998**

(51) **Int. Cl.⁷** **H01Q 1/24**

(52) **U.S. Cl.** **345/702; 343/700 MS; 343/850; 343/895**

(58) **Field of Search** **343/700 MS, 702, 343/850, 851, 852, 895**

(56) **References Cited**

U.S. PATENT DOCUMENTS

676,332 A	6/1901	Marconi	
1,837,678 A	12/1931	Ryder	
2,966,679 A	12/1960	Harris	343/895
2,993,204 A	7/1961	Macalpine	343/745
3,573,840 A	4/1971	Gouillou	343/745
4,012,744 A	3/1977	Greiser	343/895
4,121,218 A	10/1978	Irwin	343/702
4,137,534 A	1/1979	Goodnight	343/752
4,161,737 A	7/1979	Albright	343/749
4,169,267 A	9/1979	Wong et al.	343/895

(List continued on next page.)

FOREIGN PATENT DOCUMENTS

AU	55898 73	11/1974
DE	31 29 045	10/1982
EP	0 372 720	6/1990
EP	0 511 577	11/1992

EP	0 522 806	1/1993
EP	0 590 671	4/1994
EP	0 593 185	4/1994
EP	0 635 898	1/1995
EP	0 644 606	3/1995
EP	0 660 440	6/1995
EP	0 747 989	12/1996
EP	0 777 293	6/1997

(List continued on next page.)

OTHER PUBLICATIONS

“A Wideband Dual Meander Sleeve Antenna” by M. Ali et al., 1995 IEEE, pp. 1124–1127.

Patent Abstracts of Japan, JP-0236602, Sep. 30, 1994.

“Antennas”, by J.D. Kraus, (McGraw-Hill Book Co., Inc.) pp. 173–178 (1950).

(List continued on next page.)

Primary Examiner—Don Wong
Assistant Examiner—Shih-Chao Chen

(74) *Attorney, Agent, or Firm*—Burns, Doane, Swecker & Mathis, L.L.P.

(57) **ABSTRACT**

The present invention seeks to overcome the above-identified deficiencies in the art by providing a built-in printed spiral antenna which is small enough to satisfy the needs of future compact mobile terminals. According to exemplary embodiments, a built-in antenna is provided which includes a printed spiral metal strip that is connected to the mobile terminal's printed circuit board via a substrate. Matching of the antenna is performed by a matching bridge which is positioned between a feeding pin and a grounded post. By adjusting the length of the matching bridge, the matching of the antenna can be changed. In an alternative embodiment, a loading resistor is attached to the matching bridge in order to enhance the bandwidth of the antenna. The size of the antenna of the present invention can be reduced to 20–30% of the conventional PIFA antenna (i.e., less than 1/10 of the wavelength of the operating frequency). As a result, the antenna can be used in a very compact chassis.

20 Claims, 7 Drawing Sheets

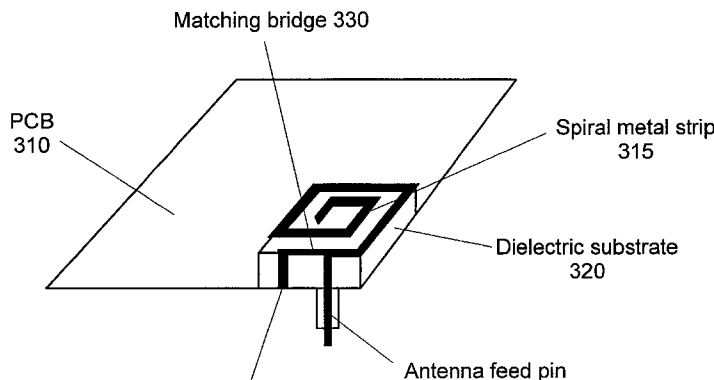

U.S. PATENT DOCUMENTS

4,229,743	A	10/1980	Vo et al.	343/749
4,356,492	A	10/1982	Kaloi	343/700 MS
4,571,595	A	2/1986	Phillips et al.	343/745
4,723,305	A	2/1988	Phillips et al.	455/89
4,742,359	A	5/1988	Ishino et al.	343/895
4,860,020	A	8/1989	Wong et al.	343/828
4,868,576	A	9/1989	Johnson, Jr.	343/702
5,020,093	A	5/1991	Pireh	379/59
5,204,687	A	4/1993	Elliott et al.	343/702
5,216,436	A	6/1993	Hall et al.	343/895
5,298,910	A	3/1994	Takei et al.	343/895
5,311,201	A	5/1994	Lillie et al.	343/791
5,317,325	A	5/1994	Bottomley	343/702
5,353,036	A	10/1994	Baldry	343/702
5,363,114	A	11/1994	Shoemaker	343/828
5,386,203	A	1/1995	Ishihara	333/129
5,436,633	A	7/1995	Liu	343/723
5,438,339	A	8/1995	Itoh et al.	343/702
5,446,469	A	8/1995	Makino	343/702
5,451,974	A	9/1995	Marino	343/895
5,467,096	A	11/1995	Takamoro et al.	343/702
5,471,221	A	* 11/1995	Nalbandian et al. .	343/700 MS
5,479,178	A	* 12/1995	Ha	343/702
5,532,703	A	* 7/1996	Stephens et al.	343/702
5,546,094	A	* 8/1996	Egashira	343/702
5,548,827	A	* 8/1996	Hanawa et al.	455/129
5,550,820	A	* 8/1996	Baran	370/60.1
5,594,457	A	* 1/1997	Wingo	343/702
5,600,335	A	2/1997	Abramo	343/749
5,612,704	A	* 3/1997	Cole	343/702
5,635,943	A	* 6/1997	Grunwell	343/702
5,661,496	A	* 8/1997	Bak et al.	343/702
5,764,197	A	* 6/1998	Tsuru et al.	343/895
5,797,084	A	* 8/1998	Tsutu et al.	455/73
5,892,490	A	* 4/1999	Asakura et al.	343/895
5,903,240	A	* 5/1999	Kawahata et al. ...	343/700 MS
5,929,825	A	* 7/1999	Niu et al.	343/895
5,949,385	A	* 9/1999	Asakura et al.	343/895

6,166,694 A * 12/2000 Ying 343/702

FOREIGN PATENT DOCUMENTS

EP	0 855 759	7/1998
EP	0 884 796	12/1998
FR	2 664 749	1/1992
GB	2175748	12/1986
JP	63-219204	9/1988
JP	5-7109	1/1993
JP	6-37531	2/1994
JP	6-90108	3/1994
JP	6-152221	5/1994
JP	H10-173430	6/1998
WO	WO93/12559	* 6/1993
WO	WO94/21003	* 9/1994
WO	96/27219	9/1996
WO	WO96/38882	* 12/1996
WO	WO97/11507	* 3/1997
WO	WO97/47054	12/1997
WO	WO97/49141	* 12/1997

OTHER PUBLICATIONS

“Microwave Scanning Antennas”, edited by R.C. Hansen, Peninsula Publishing, pp. 116–122 (1950).

European Search Report, File No. RS 102645 US, date of mailing, Mar. 31, 1999.

“FDTD Analysis of Printed Square Spiral Antennas for Wireless Communications”, J. Chen, et al., IEEE Antennas and Propagation Society International Symposium 1997 Digest, vol. 3, Jul. 14, 1997, pps. 1550–1553.

“Spectral Domain Analysis of a Square Microstrip Spiral Antenna”, S.C. Wu, et al., Proceedings of the Antennas and Propagation Society Annual Meeting, 1991, vol. 2, Jan. 1991, pps. 970–973.

* cited by examiner

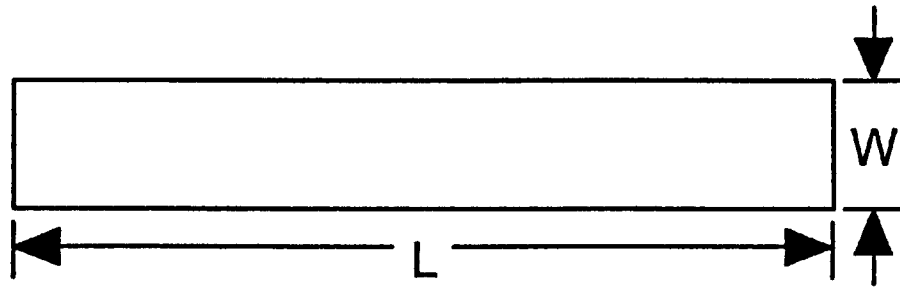

FIG. 1A

PRIOR ART

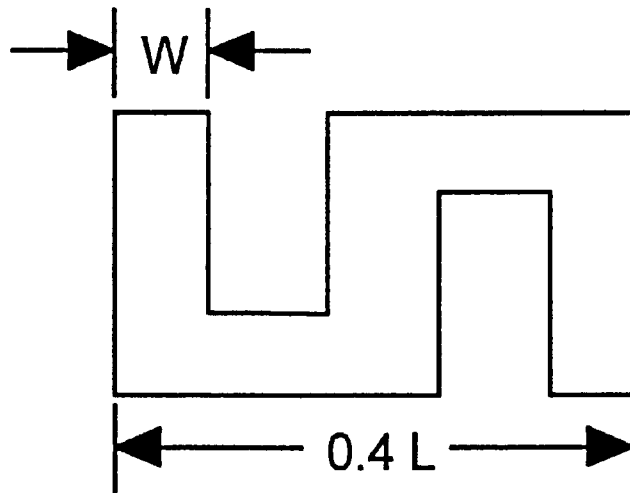

FIG. 1B

PRIOR ART

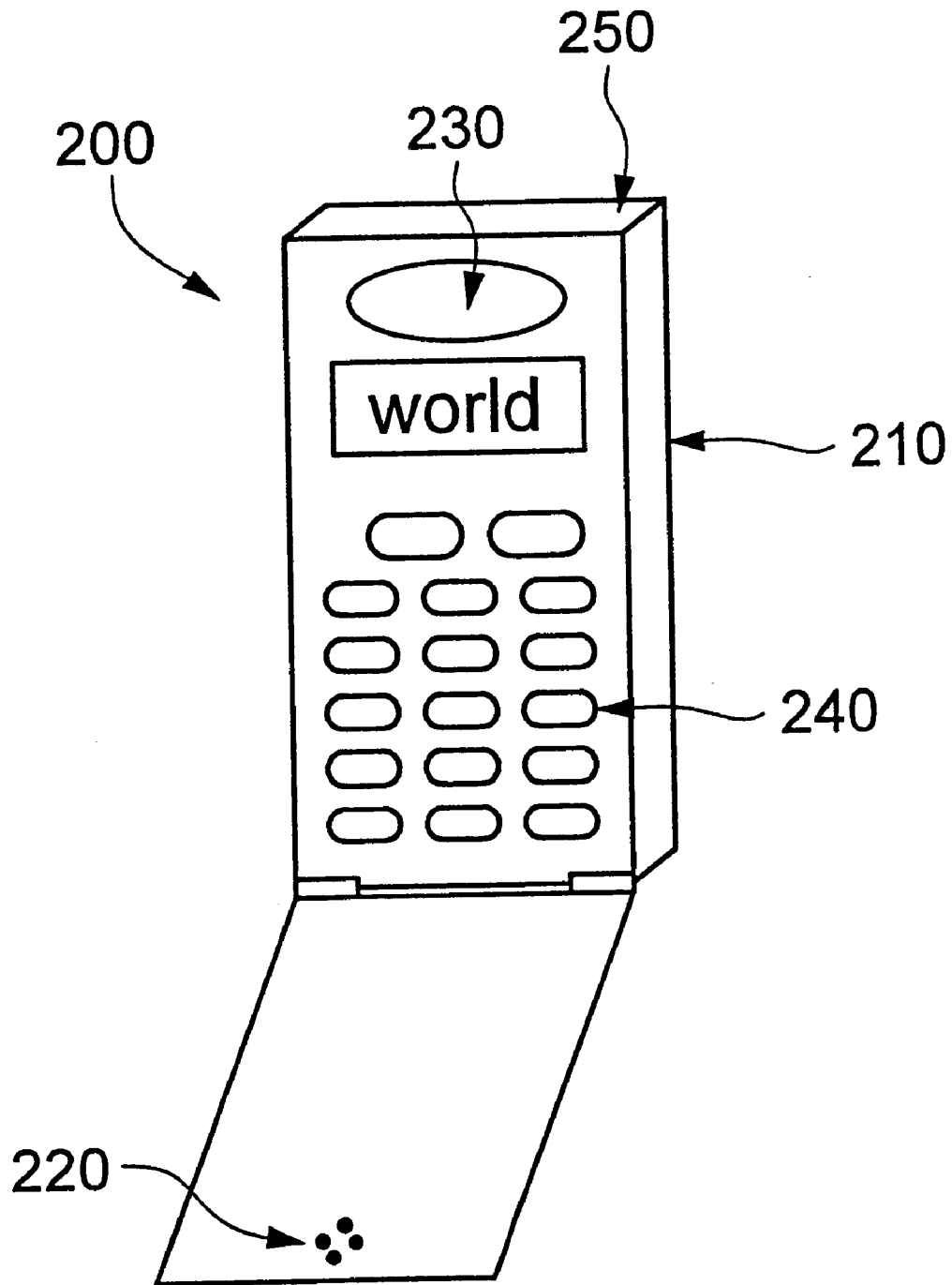
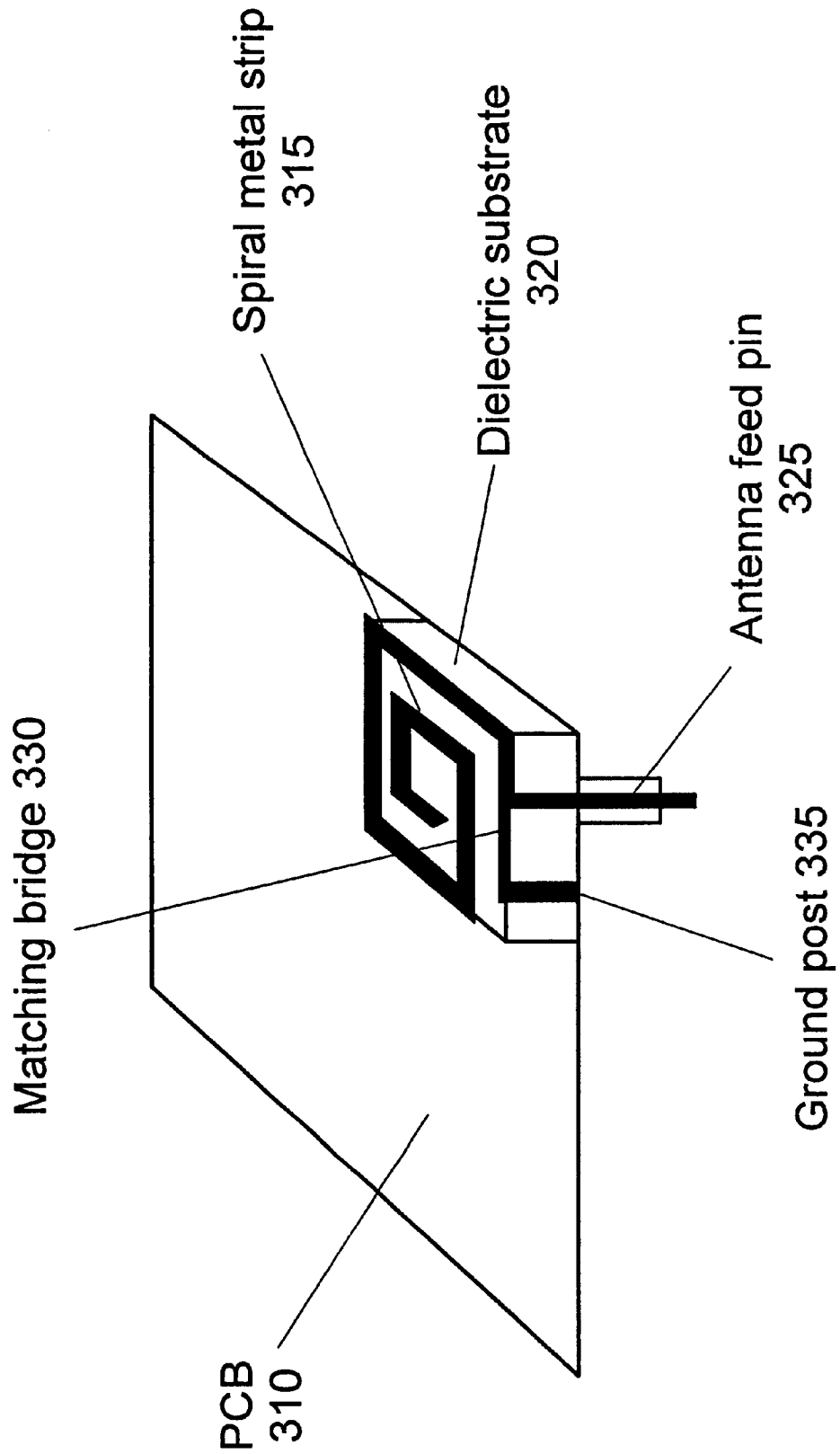

FIG. 2

FIG. 3



Explore Litigation Insights

Docket Alarm provides insights to develop a more informed litigation strategy and the peace of mind of knowing you're on top of things.

Real-Time Litigation Alerts



Keep your litigation team up-to-date with **real-time alerts** and advanced team management tools built for the enterprise, all while greatly reducing PACER spend.

Our comprehensive service means we can handle Federal, State, and Administrative courts across the country.

Advanced Docket Research



With over 230 million records, Docket Alarm's cloud-native docket research platform finds what other services can't. Coverage includes Federal, State, plus PTAB, TTAB, ITC and NLRB decisions, all in one place.

Identify arguments that have been successful in the past with full text, pinpoint searching. Link to case law cited within any court document via Fastcase.

Analytics At Your Fingertips



Learn what happened the last time a particular judge, opposing counsel or company faced cases similar to yours.

Advanced out-of-the-box PTAB and TTAB analytics are always at your fingertips.

API

Docket Alarm offers a powerful API (application programming interface) to developers that want to integrate case filings into their apps.

LAW FIRMS

Build custom dashboards for your attorneys and clients with live data direct from the court.

Automate many repetitive legal tasks like conflict checks, document management, and marketing.

FINANCIAL INSTITUTIONS

Litigation and bankruptcy checks for companies and debtors.

E-DISCOVERY AND LEGAL VENDORS

Sync your system to PACER to automate legal marketing.