



US006366622B1

(12) **United States Patent**  
**Brown et al.**

(10) **Patent No.:** **US 6,366,622 B1**  
(45) **Date of Patent:** **Apr. 2, 2002**

(54) **APPARATUS AND METHOD FOR WIRELESS COMMUNICATIONS**

(75) Inventors: **Stephen Joseph Brown; Andrew Xavier Estrada**, both of San Diego; **Terrance R. Bourk**, La Jolla; **Steven R. Norsworthy**, Solana Beach; **Patrick J. Murphy; Christopher Dennis Hull**, both of San Diego; **Glenn Chang**, Laguna Niguel; **Mark Vernon Lane**, San Diego; **Jorge A. Grilo**, Foothill Ranch, all of CA (US)

(73) Assignee: **Silicon Wave, Inc.**, San Diego, CA (US)

(\*) Notice: Subject to any disclaimer, the term of this patent is extended or adjusted under 35 U.S.C. 154(b) by 0 days.

(21) Appl. No.: **09/305,330**

(22) Filed: **May 4, 1999**

**Related U.S. Application Data**

(63) Continuation-in-part of application No. 09/216,040, filed on Dec. 18, 1998, now abandoned.

(51) Int. Cl.<sup>7</sup> ..... **H04B 1/30; H04L 27/18**

(52) U.S. Cl. .... **375/322; 375/133; 375/222; 375/281; 375/345; 329/304**

(58) **Field of Search** ..... **375/132, 133, 375/136, 219, 222, 259, 279, 281, 316, 326, 327, 329, 332, 345; 329/304, 306, 307, 308; 455/234.1, 257, 276.1**

(56) **References Cited**

**U.S. PATENT DOCUMENTS**

5,144,308 A 9/1992 Norsworthy ..... 341/131

(List continued on next page.)

**FOREIGN PATENT DOCUMENTS**

JP 6053422 A 2/1994 ..... H01I/27/06

(List continued on next page.)

**OTHER PUBLICATIONS**

Bluetooth Special Interest Group website <http://www.bluetooth.com>; "Bluetooth—Document Page", including "Tech-

nology Overview", "Radio", "Baseband", "Link Management", "Software Framework", "PC General", "Telephone", "Others"; Date Unknown; pp. 1-10.

(List continued on next page.)

*Primary Examiner*—Young T. Tse

(74) *Attorney, Agent, or Firm*—Martin J. Jaquez, Esq.; Jaquez & Associates

(57) **ABSTRACT**

An apparatus for receiving signals includes a low noise amplifier (LNA) configured to receive a radio frequency (RF) signal. An I/Q direct down converter is coupled to the LNA. The I/Q direct down converter is configured to split the RF signal into real and imaginary components and to down convert the real and imaginary components directly to baseband signals. A local oscillator (LO) is coupled to the I/Q direct down converter and is configured to drive the I/Q direct down converter. First and second filters are coupled to the I/Q direct down converter. The first and second filters are configured to filter the down converted real and imaginary components, respectively. First and second analog-to-digital converters (ADCs) are coupled to the first and second filters, respectively. The first and second ADCs are configured to convert the real and imaginary components into digital signals. The first and second ADCs have a dynamic range that is wide enough to convert the filtered, down converted real and imaginary components to digital signals without using variable gain on the filtered and down converted real and imaginary components. An apparatus for use in wireless communications includes a radio, a modem and a controller integrated onto a single integrated circuit (IC). The radio includes a receiver for receiving data and a transmitter for transmitting data. The modem is coupled to the radio and is configured to demodulate received data and modulate data for transmission. The controller is coupled to the modem and includes a digital interface for external communications through which received data and data for transmission is sent, a connection state machine configured to accept commands through the digital interface and to respond to the commands by initiating a sequence, and a receive/transmit state machine configured to perform state control of the radio in response to the initiated sequence.

**38 Claims, 45 Drawing Sheets-**

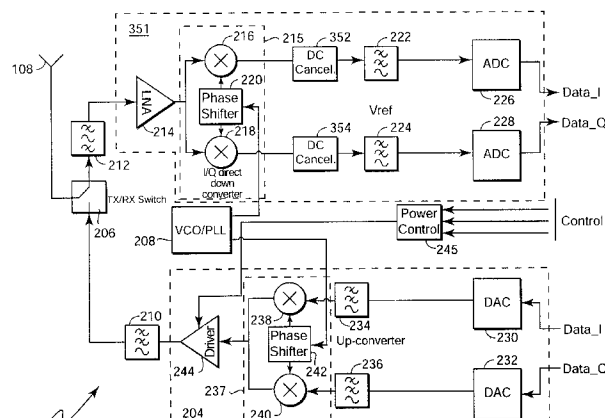

U.S. PATENT DOCUMENTS

5,279,978	A	1/1994	See et al. ....	437/34
5,294,823	A	3/1994	Eklund et al. ....	257/370
5,339,040	A	8/1994	Loper .....	329/358
5,424,739	A	6/1995	Norsworthy et al. ....	341/143
5,430,317	A	7/1995	Onai et al. ....	257/347
5,449,953	A	9/1995	Nathanson et al. ....	257/728
5,498,885	A	3/1996	Deen et al. ....	257/139
5,578,970	A	11/1996	Nguyen et al. ....	331/75
5,619,069	A	4/1997	Ohta et al. ....	257/692
5,643,805	A	7/1997	Ohta et al. ....	437/31
5,661,329	A	8/1997	Hiramoto et al. ....	257/510
5,684,482	A	11/1997	Galton .....	341/144
5,708,971	A	* 1/1998	Dent .....	455/38.3
5,724,653	A	* 3/1998	Baker et al. ....	455/296
5,745,061	A	4/1998	Norsworthy et al. ....	341/131
5,757,921	A	5/1998	Okanobu et al. ....	380/38
5,773,340	A	6/1998	Kumauchi et al. ....	438/234
5,799,010	A	* 8/1998	Lomp et al. ....	370/335
5,825,887	A	* 10/1998	Lennen .....	380/34
5,930,286	A	* 7/1999	Walley .....	375/140

FOREIGN PATENT DOCUMENTS

JP	8241999	9/1996	.....	H01L/29/786
----	---------	--------	-------	-------------

WO	WO 9625790	8/1996	
WO	WO 97/02602	1/1997	..... H01L/27/12
WO	WO 98/49779	11/1998	..... H04B/1/38

OTHER PUBLICATIONS

Durec, Jeff, "An Integrated Silicon Bipolar Receiver Subsystem for 900-Mhz ISM Band Applications" *IEEE Journal of Solid State Circuits* 33(9):1352-1372 (Sep. 1998).

Hashimoto et al., "A 6- $\mu$  m<sup>2</sup> bipolar transistor using 0.25- $\mu$  m process technology for high-speed applications" *IEEE Proceedings of the Bipolar BiCMOS Circuits and Technology Meeting*: 152-155 (Sep. 1998).

IEEE Personal Communications, "Figure 3. A Wireless-enhanced scenario for PCCAs", Dec. 1998, p. 1.

Kikuchi et al., "A 0.35 $\mu$ m ECL-CMOS Process Technology on SOI for Ins Mega-bits SRAM's with 40ps Gate Array" *International Electronic Devices Meeting Technical Digest* 95:923-926 (Dec. 1995).

Sze, S.M., *Semiconductor Devices, Physics and Technology*, New Jersey, John Wiley & Sons, 1985., p. 468-472. ISBN 0-471-87424-8.

\* cited by examiner

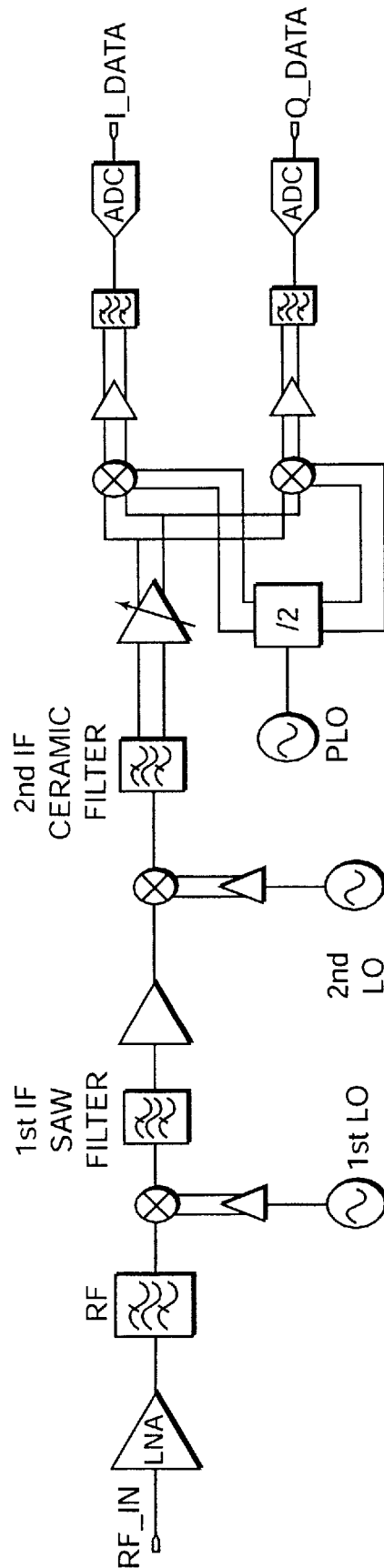

FIG. 1  
(PRIOR ART)

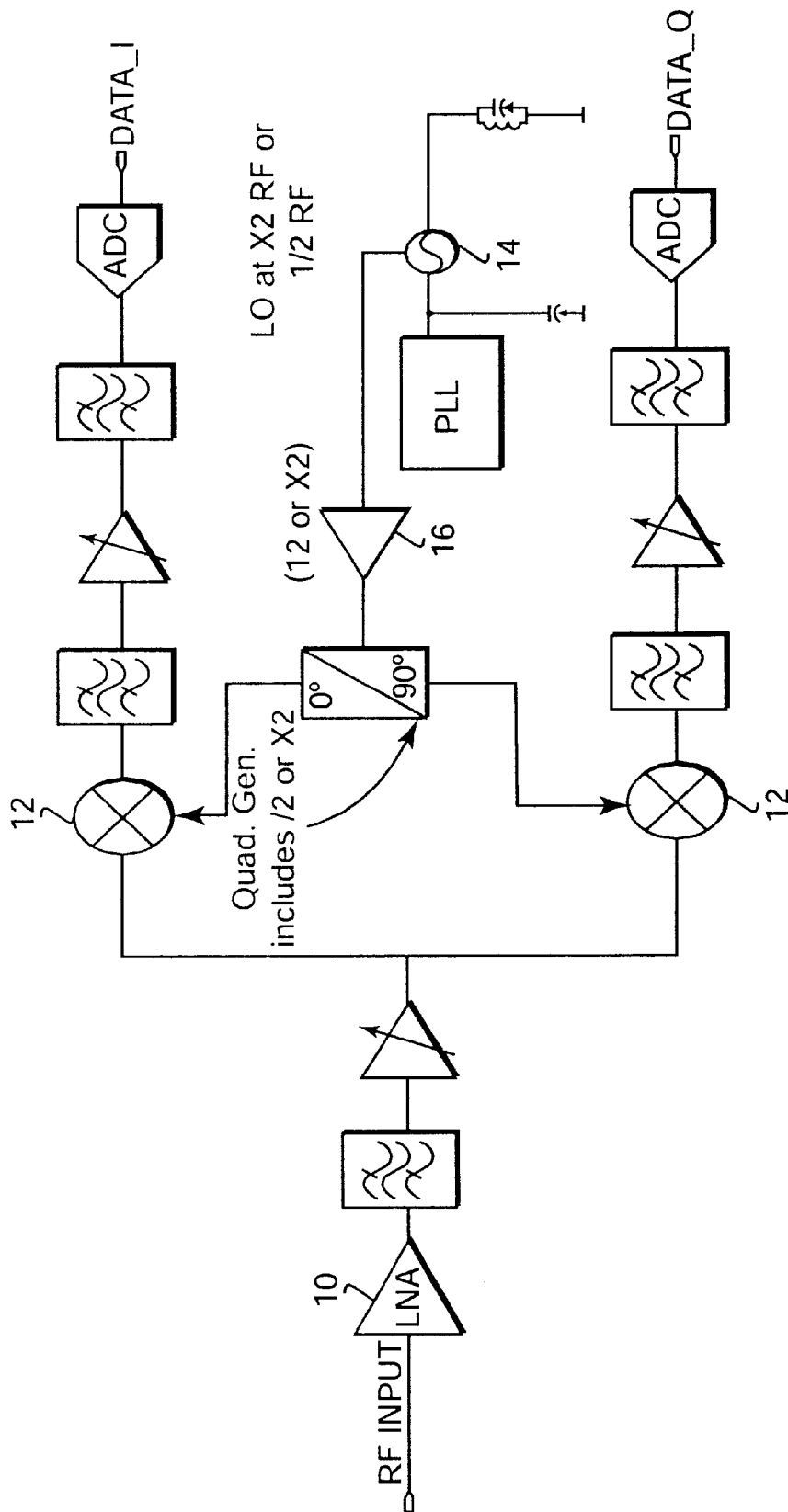

FIG. 2  
(PRIOR ART)

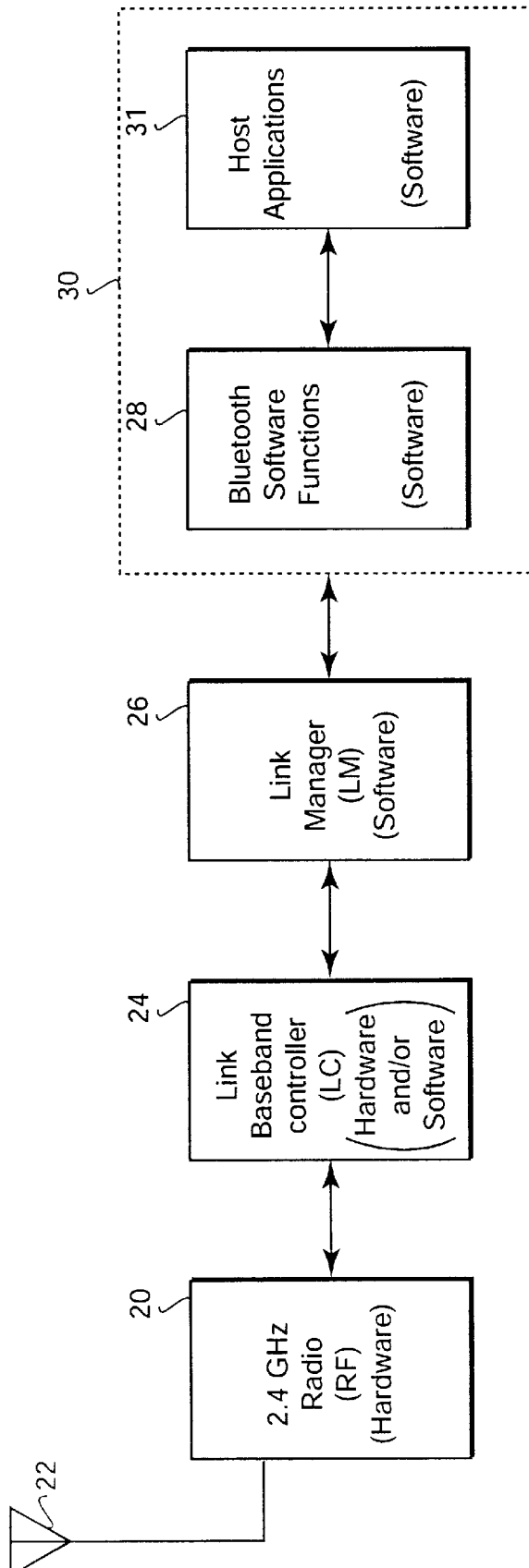

FIG. 3  
(PRIOR ART)

# Explore Litigation Insights

Docket Alarm provides insights to develop a more informed litigation strategy and the peace of mind of knowing you're on top of things.

## Real-Time Litigation Alerts



Keep your litigation team up-to-date with **real-time alerts** and advanced team management tools built for the enterprise, all while greatly reducing PACER spend.

Our comprehensive service means we can handle Federal, State, and Administrative courts across the country.

## Advanced Docket Research



With over 230 million records, Docket Alarm's cloud-native docket research platform finds what other services can't. Coverage includes Federal, State, plus PTAB, TTAB, ITC and NLRB decisions, all in one place.

Identify arguments that have been successful in the past with full text, pinpoint searching. Link to case law cited within any court document via Fastcase.

## Analytics At Your Fingertips



Learn what happened the last time a particular judge, opposing counsel or company faced cases similar to yours.

Advanced out-of-the-box PTAB and TTAB analytics are always at your fingertips.

## API

Docket Alarm offers a powerful API (application programming interface) to developers that want to integrate case filings into their apps.

## LAW FIRMS

Build custom dashboards for your attorneys and clients with live data direct from the court.

Automate many repetitive legal tasks like conflict checks, document management, and marketing.

## FINANCIAL INSTITUTIONS

Litigation and bankruptcy checks for companies and debtors.

## E-DISCOVERY AND LEGAL VENDORS

Sync your system to PACER to automate legal marketing.