



US006359998B1

(12) **United States Patent**
Cooklev

(10) **Patent No.:** **US 6,359,998 B1**
(45) **Date of Patent:** **Mar. 19, 2002**

(54) **METHOD AND APPARATUS FOR WAVELET-BASED DIGITAL WATERMARKING**

(75) Inventor: **Todor Cooklev**, Salt Lake City, UT (US)

(73) Assignee: **3Com Corporation**, Santa Clara, CA (US)

(*) Notice: Subject to any disclaimer, the term of this patent is extended or adjusted under 35 U.S.C. 154(b) by 0 days.

(21) Appl. No.: **09/065,815**

(22) Filed: **Apr. 23, 1998**

(51) **Int. Cl.**⁷ **G06K 9/00**

(52) **U.S. Cl.** **382/100; 382/248**

(58) **Field of Search** 382/100, 101, 382/118, 119, 120, 212, 232, 248, 249, 250, 276, 280, 284, 293, 296; 380/54, 210, 252, 287; 713/176

(56) **References Cited**

U.S. PATENT DOCUMENTS

4,405,829	A	*	9/1983	Rivest et al.	178/22
5,721,788	A	*	2/1998	Powell et al.	382/100
5,745,604	A	*	4/1998	Rhoads	382/232
5,809,160	A	*	9/1998	Powell et al.	382/100
5,889,868	A	*	3/1999	Moskowitz et al.	380/51
5,905,819	A	*	5/1999	Daly	382/284
5,915,027	A	*	6/1999	Cox et al.	380/54
5,930,369	A	*	7/1999	Cox et al.	380/54
5,930,377	A	*	7/1999	Powell et al.	382/100
5,946,103	A	*	8/1999	Curry	358/405
6,031,914	A	*	2/2000	Tewfik et al.	380/54
6,061,793	A	*	5/2000	Tewfik et al.	713/176
6,208,735	B1	*	3/2001	Cox et al.	380/54

OTHER PUBLICATIONS

Areepongsa et al. (Steganography for a low bit-rate wavelet based image coder, Jul. 2000, IEEE).*

Areepongsa et al. (Exploring steganography for low bit rate wavelet based coder in image retrieval system, Aug. 2000, IEEE).*

Chae et al. (A robust embedded data from wavelet coefficients, Dec. 1997, SPIE, vol. 3312).*

Inoue et al. (A digital watermark technique based on the wavelet transform and its robustness on image compression and transformation, SCIS, 1998).*

Onishi et al. (Wavelet detection of watermark from a clipped picture using wavelet, Jul. 1997, ITE Technical).*

Ishizuka et al. (On an experimental evaluation of steganography with wavelet transform, SCIS, 1997).*

Matsui et al. (Embedding a signature to pictures under wavelet transformation, Jun. 1996, IEICE).*

Cooklev et al., Two-Channel Multifilter Banks and Multi-wavelets, IEEE Publication No. 0-7803-3192, Mar. 1996.

* cited by examiner

Primary Examiner—Andrew W. Johns

Assistant Examiner—Amir Alavi

(74) *Attorney, Agent, or Firm*—Workman, Nydegger & Seeley

(57) **ABSTRACT**

The disclosed watermarking method utilizes a transform technique for inserting an imperceptible digital watermark into digital data that is strongly resistant to unauthorized detection and decoding. Methods for embedding a watermark that is sufficiently robust to lossy compression and other image processing operations such as rescaling are also provided. The watermarking principle is based on wavelet transforms where the coefficients of the filters have binary values, and are thus very attractive for practical realization. The wavelet filters utilize complimentary polynomials and implement non-regular wavelet transforms upon which the digital watermark is inserted. Following the inverse transformation process, the digital watermark is spread across multiple frequencies of the original digital data thereby reducing the impact of signal processing operations such as compression or other frequency filtering based operations. Additional embodiments employing complimentary matrix polynomials which are closely related to multifilter banks are also provided.

23 Claims, 6 Drawing Sheets

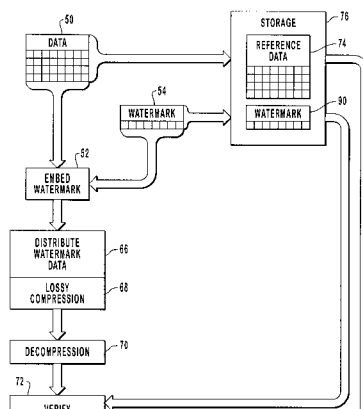

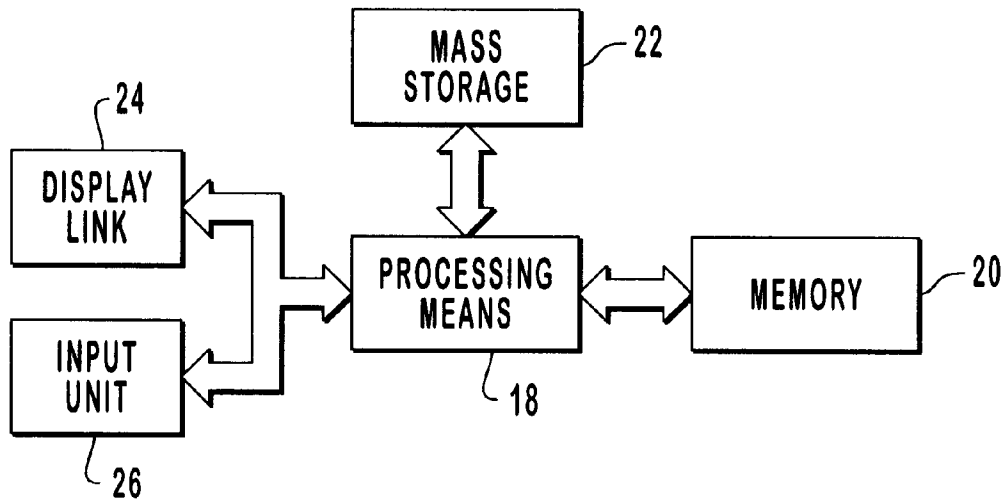

FIG. 1

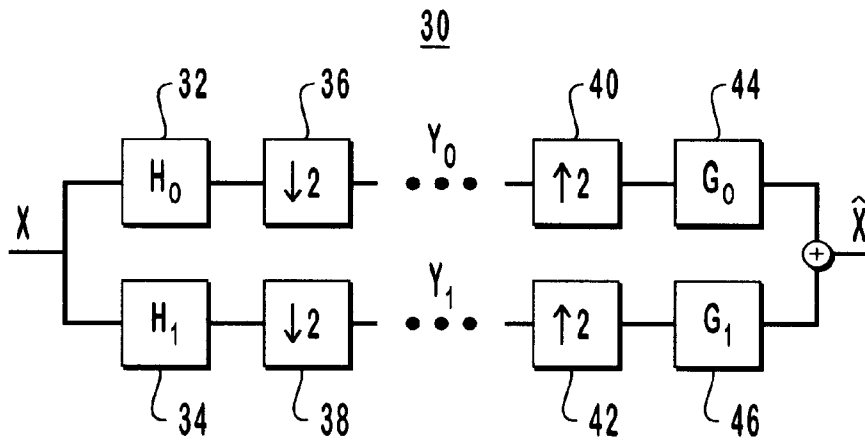

FIG. 2

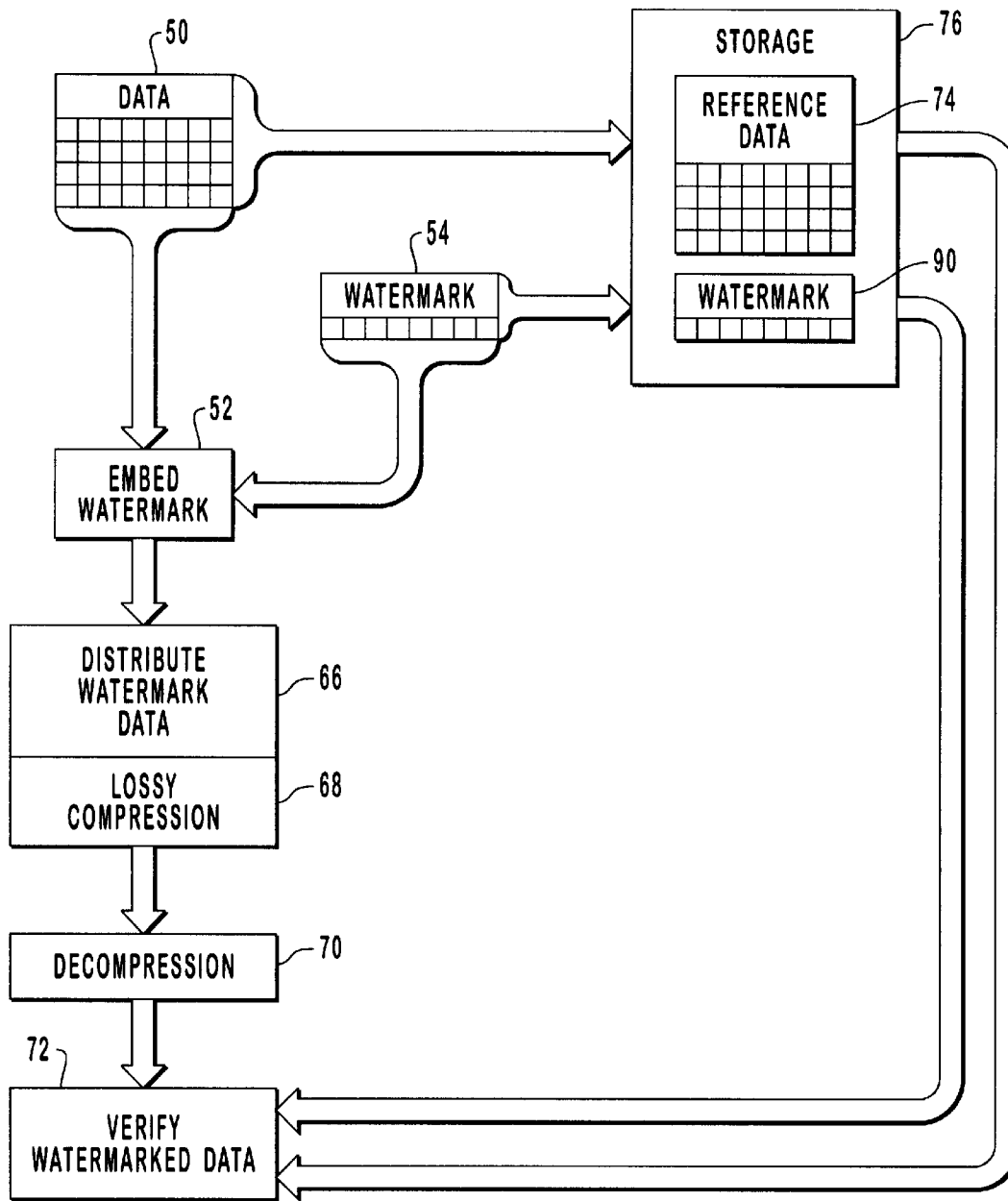

FIG. 3

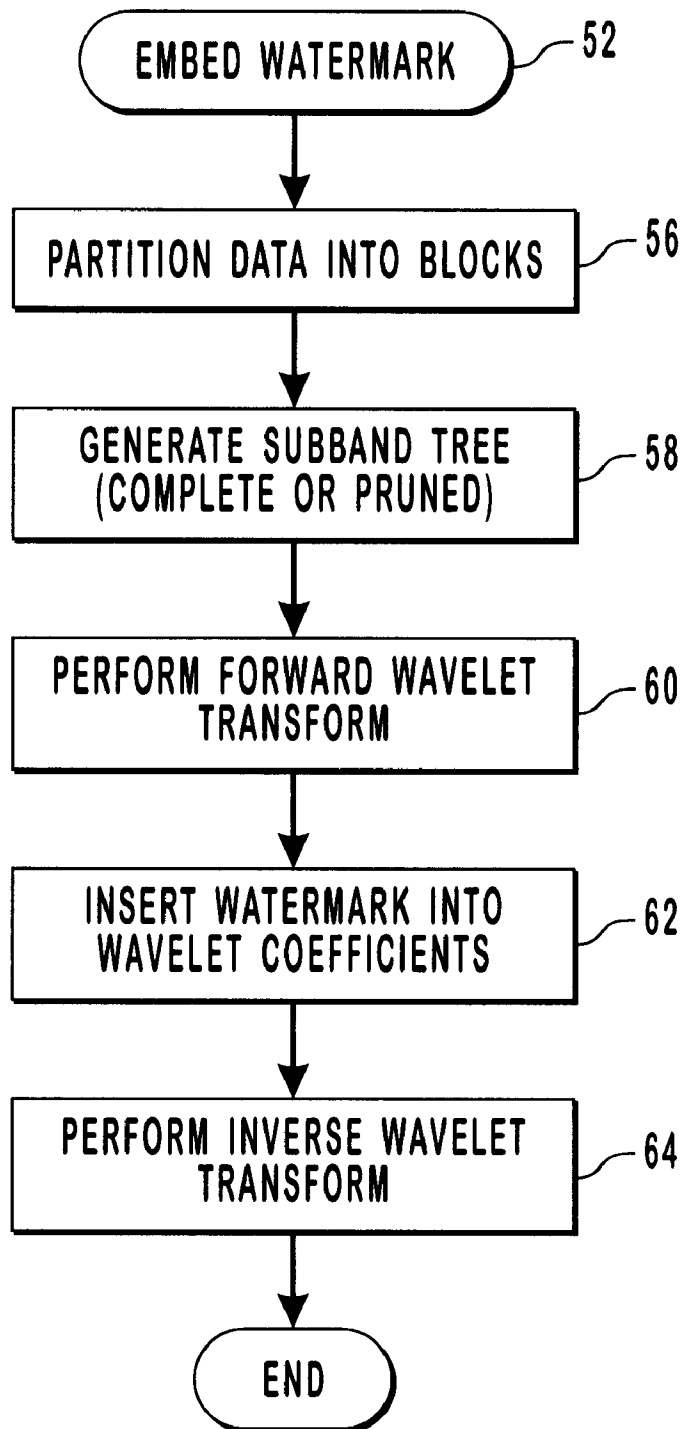

FIG. 4

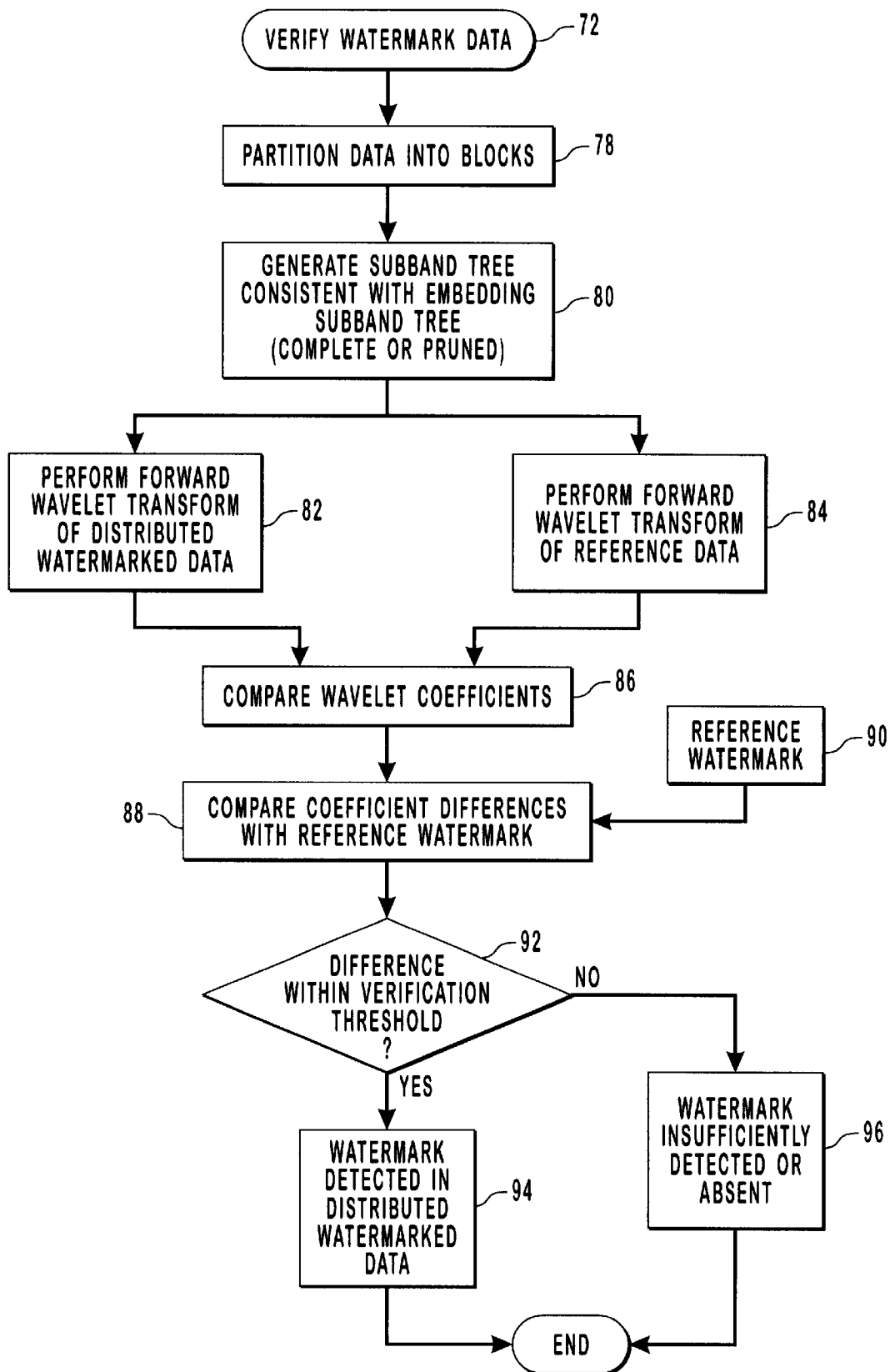

FIG. 5

Explore Litigation Insights

Docket Alarm provides insights to develop a more informed litigation strategy and the peace of mind of knowing you're on top of things.

Real-Time Litigation Alerts



Keep your litigation team up-to-date with **real-time alerts** and advanced team management tools built for the enterprise, all while greatly reducing PACER spend.

Our comprehensive service means we can handle Federal, State, and Administrative courts across the country.

Advanced Docket Research



With over 230 million records, Docket Alarm's cloud-native docket research platform finds what other services can't. Coverage includes Federal, State, plus PTAB, TTAB, ITC and NLRB decisions, all in one place.

Identify arguments that have been successful in the past with full text, pinpoint searching. Link to case law cited within any court document via Fastcase.

Analytics At Your Fingertips



Learn what happened the last time a particular judge, opposing counsel or company faced cases similar to yours.

Advanced out-of-the-box PTAB and TTAB analytics are always at your fingertips.

API

Docket Alarm offers a powerful API (application programming interface) to developers that want to integrate case filings into their apps.

LAW FIRMS

Build custom dashboards for your attorneys and clients with live data direct from the court.

Automate many repetitive legal tasks like conflict checks, document management, and marketing.

FINANCIAL INSTITUTIONS

Litigation and bankruptcy checks for companies and debtors.

E-DISCOVERY AND LEGAL VENDORS

Sync your system to PACER to automate legal marketing.