

UNITED STATES PATENT AND TRADEMARK OFFICE

BEFORE THE PATENT TRIAL AND APPEAL BOARD

SAMSUNG ELECTRONICS CO., LTD.,
SAMSUNG ELECTRONICS AMERICA, INC. and APPLE INC.,
Petitioner,

v.

SMART MOBILE TECHNOLOGIES LLC,
Patent Owner.

IPR2022-01249
Patent 9,019,946 B1

Before HYUN J. JUNG, GARTH D. BAER, and AARON W. MOORE,
Administrative Patent Judges.

JUNG, *Administrative Patent Judge.*

DECISION
Granting Institution of *Inter Partes* Review
35 U.S.C. § 314

I. INTRODUCTION

A. *Background and Summary*

Samsung Electronics Co., Ltd., Samsung Electronics America, Inc., and Apple Inc. (collectively, “Petitioner”) filed a Petition (Paper 3, “Pet.”) requesting institution of an *inter partes* review of claims 1–21 and 26–30 of U.S. Patent No. 9,019,946 B1 (Ex. 1001, “the ’946 patent”). Smart Mobile Technologies LLC (“Patent Owner”) filed a Preliminary Response (Paper 7, “Prelim. Resp.”). With our authorization, the parties filed additional briefs directed solely to the issue of inconsistent claim constructions between this proceeding and related litigation. Papers 11, 12.

Under 35 U.S.C. § 314, an *inter partes* review may not be instituted “unless . . . there is a reasonable likelihood that the petitioner would prevail with respect to at least 1 of the claims challenged in the petition.” Upon consideration of the Petition in view of the present record and for the reasons explained below, we determine that Petitioner has shown a reasonable likelihood of prevailing with respect to at least one of the challenged claims.

Thus, we institute an *inter partes* review of claims 1–21 and 26–30 of the ’946 patent on all presented challenges. *SAS Inst. Inc. v. Iancu*, 138 S. Ct. 1348, 1359–60 (2018).

B. *Real Parties in Interest*

Petitioner identifies Samsung Electronics Co., Ltd., Samsung Electronics America, Inc., and Apple Inc. as real parties in interest. Pet. 86. Patent Owner only identifies itself as a real party in interest. Paper 5, 1.

C. *Related Matters*

The parties identify *Smart Mobile Techs. LLC v. Apple Inc.*, 6:21-cv-00603 (W.D. Tex.) and *Smart Mobile Techs. LLC v. Samsung Elecs. Co., Ltd.*, 6:21-cv-00701 (W.D. Tex.) as related matters. Pet. 86; Paper 5, 1.

We instituted *inter partes* reviews of related patents. *Samsung Elecs. Co., Ltd. v. Smart Mobile Techs. LLC*, IPR2022-00766, Paper 14 (PTAB Oct. 26, 2022) (Decision Granting Institution); *Samsung Elecs. Co., Ltd. v. Smart Mobile Techs. LLC*, IPR2022-01004, Paper 13 (PTAB Dec. 5, 2022) (Decision Granting Institution); *Samsung Elecs. Co., Ltd. v. Smart Mobile Techs. LLC*, IPR2022-01005, Paper 10 (PTAB Dec. 5, 2022) (Decision Granting Institution). Other related patents are challenged in IPR2022-01223 and IPR2022-01248.

D. The '946 Patent (Ex. 1001)

The '946 patent issued on April 28, 2015, from an application filed on September 8, 2014, which is a continuation application of several previously filed continuation and continuation-in-part applications, the earliest of which was filed on June 4, 1999. Ex. 1001, codes (22), (45), (63), 1:8–19.

According to the '946 patent, an unfulfilled need exists for multiple transmitters and receivers (“T/R”) in a cellular telephone or mobile wireless device (“CT/MD”). Ex. 1001, 1:48–49. Figure 5A of the '946 patent is reproduced below.

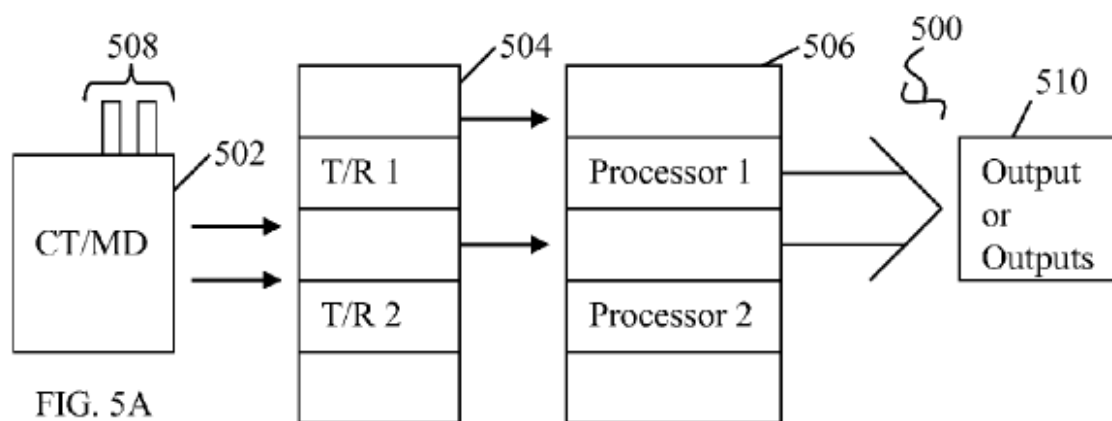

Figure 5A shows a “a dual antenna, dual T/R unit in a CT/MD interfacing with a dual processor.” Ex. 1001, 2:15–17. Dual antenna 508 and dual T/R unit 504 interface with dual processor 506 in dual band

system 500. *Id.* at 4:37–39. System 500 can communicate through outputs 510, which can be “fibre optic channel, ethernet, cable, telephone, or other.” *Id.* at 4:42–45.

“The multiple processors 506 allow for parallel and custom processing of each signal or data stream to achieve higher speed and better quality of output.” Ex. 1001, 4:51–53. Processors 506 include “DSP, CPU, memory controller, and other elements essential to process various types of signals.” *Id.* at 4:56–58.

“The processor contained within the CT/MD 502 is further capable of delivering the required outputs to a number of different ports such as optical, USB, cable and others” and “capable of taking different inputs, as well as wireless.” *Id.* at 4:60–64. “Thus the CT/MD 502 has universal connectivity in addition to having a wide range of functionality made possible through the features of multiple antennas, multiple T/R units 504 and processors 506.” *Id.* at 4:67–5:3.

“[T]he CT/MD may use one or more transmission protocols as deemed optimal and appropriate,” and “the CT/MD determines the required frequency spectrum, other wireless parameters such as power and signal to noise ratio to optimally transmit the data.” Ex. 1001, 11:5–7, 11:9–11:11. The CT/MD has “the ability to multiplex between one or more transmission protocols such as CDMA, TDMA to ensure that the fast data rates of the optical network or matched closely in a wireless network to minimize the potential data transmission speed degradation of a wireless network.” *Id.* at 11:12–15. “Thus it is possible that various optical and wireless protocols can co-exist in a network.” *Id.* at 11:29–30.

E. Illustrative Claim

The '943 patent includes 30 claims, of which Petitioner challenges claims 1–21 and 26–30. Of the challenged claims, claims 1, 14, 17, and 27 are independent, and reproduced below is claim 14.

14. An Internet-enabled mobile communication device comprising:

a memory;

a display;

at least two or more antennas;

at least one or more processors; and

a plurality of wireless transmit and receive units including a first wireless transmit and receive unit and a second wireless transmit and receive unit, wherein each wireless transmit receive unit is configured to communicate using one or more protocols;

wherein the device is enabled for communication using Internet Protocol (IP);

wherein the device is enabled for wireless communication on a wireless local area network;

wherein the first wireless transmit and receive unit is enabled to communicate using one or more antennas simultaneously; and

wherein the mobile device maintains multiple IP addresses, wherein the first wireless unit is accessible on a first IP address and the second wireless transmit and receive unit is accessible on a second IP address and wherein the mobile device operates using a plurality of ports; and

wherein data transferred by the plurality of transmit and receive units is improved by the simultaneous use of multiple network paths including at least one connection to a networked server; and

wherein the device is enabled for communication of wireless signals representing voice data and for communication of wireless signals representing non-voice data.

Ex. 1001, 13:17–47.

Explore Litigation Insights

Docket Alarm provides insights to develop a more informed litigation strategy and the peace of mind of knowing you're on top of things.

Real-Time Litigation Alerts



Keep your litigation team up-to-date with **real-time alerts** and advanced team management tools built for the enterprise, all while greatly reducing PACER spend.

Our comprehensive service means we can handle Federal, State, and Administrative courts across the country.

Advanced Docket Research



With over 230 million records, Docket Alarm's cloud-native docket research platform finds what other services can't. Coverage includes Federal, State, plus PTAB, TTAB, ITC and NLRB decisions, all in one place.

Identify arguments that have been successful in the past with full text, pinpoint searching. Link to case law cited within any court document via Fastcase.

Analytics At Your Fingertips



Learn what happened the last time a particular judge, opposing counsel or company faced cases similar to yours.

Advanced out-of-the-box PTAB and TTAB analytics are always at your fingertips.

API

Docket Alarm offers a powerful API (application programming interface) to developers that want to integrate case filings into their apps.

LAW FIRMS

Build custom dashboards for your attorneys and clients with live data direct from the court.

Automate many repetitive legal tasks like conflict checks, document management, and marketing.

FINANCIAL INSTITUTIONS

Litigation and bankruptcy checks for companies and debtors.

E-DISCOVERY AND LEGAL VENDORS

Sync your system to PACER to automate legal marketing.