



(19) **United States**

(12) **Patent Application Publication**
Hwang et al.

(10) **Pub. No.: US 2004/0174152 A1**

(43) **Pub. Date: Sep. 9, 2004**

(54) **PULSE-SKIPPING SWITCHING POWER CONVERTER**

(52) **U.S. Cl. 323/284**

(76) Inventors: **Jeffrey H. Hwang**, Saratoga, CA (US);
Joe Wong, Daly City, CA (US)

(57) **ABSTRACT**

Correspondence Address:
CHAMPION MICROELECTRONIC CORPORATION
HSINCHU SCIENCE- BASED INDUSTRIAL PARK
5F, No. 11, PARK AVENUE II
HSINCHU CITY (TW)

The invention relates to a pulse-skipping power converter. In one aspect, a power converter has two stages. When the load is high, both stages are enabled. As the load decreases, one or both of the stages may enter pulse-skipping mode to improve efficiency. As the load is reduced further, the one or both of the stages may be disabled. When both stages are disabled, an auxiliary power supply may be enabled. In a further aspect, an error signal is produced by comparing a signal representative of an output voltage or current of the power converter relative to a level. A pulse-width modulation (PWM) signal including a series of pulses is produced by comparing the error signal to a ramp signal. The duty cycle of the PWM signal is compared to a reference duty cycle. If the duty cycle of the PWM signal is less than the reference duty cycle then the next pulse in the PWM signal is skipped.

(21) Appl. No.: **10/379,882**

(22) Filed: **Mar. 4, 2003**

Publication Classification

(51) **Int. Cl.⁷ G05F 1/40**

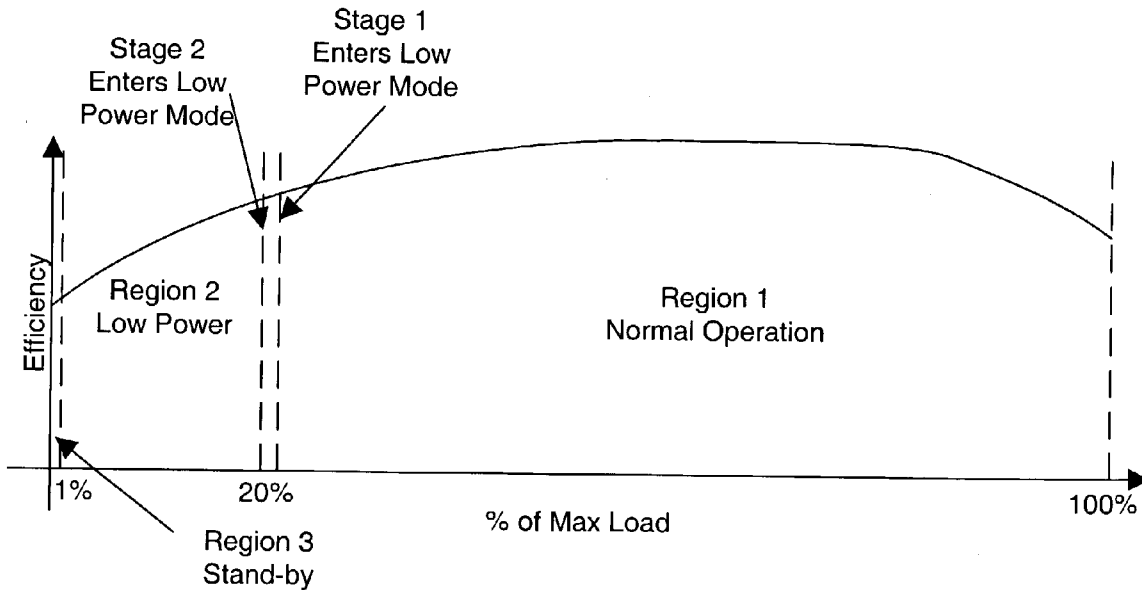

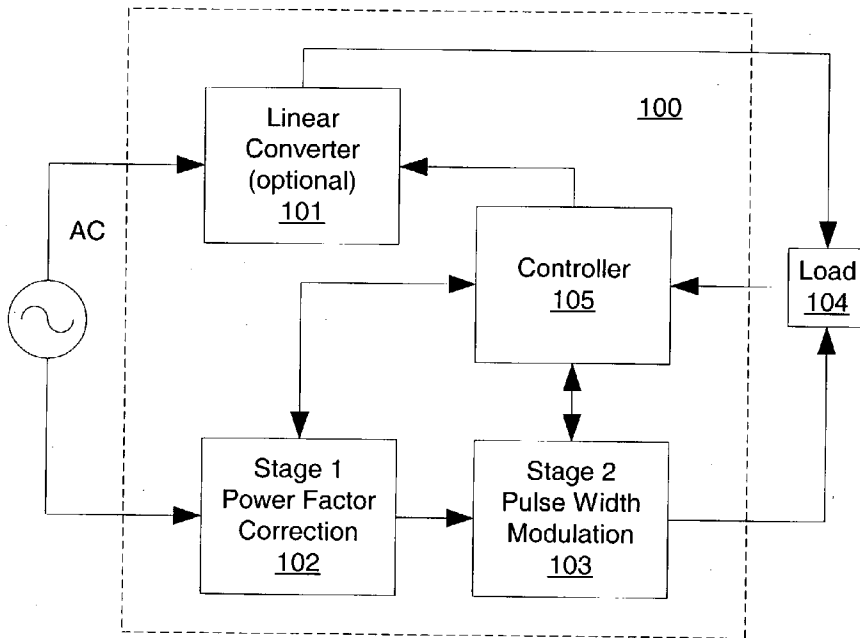

FIG. 1

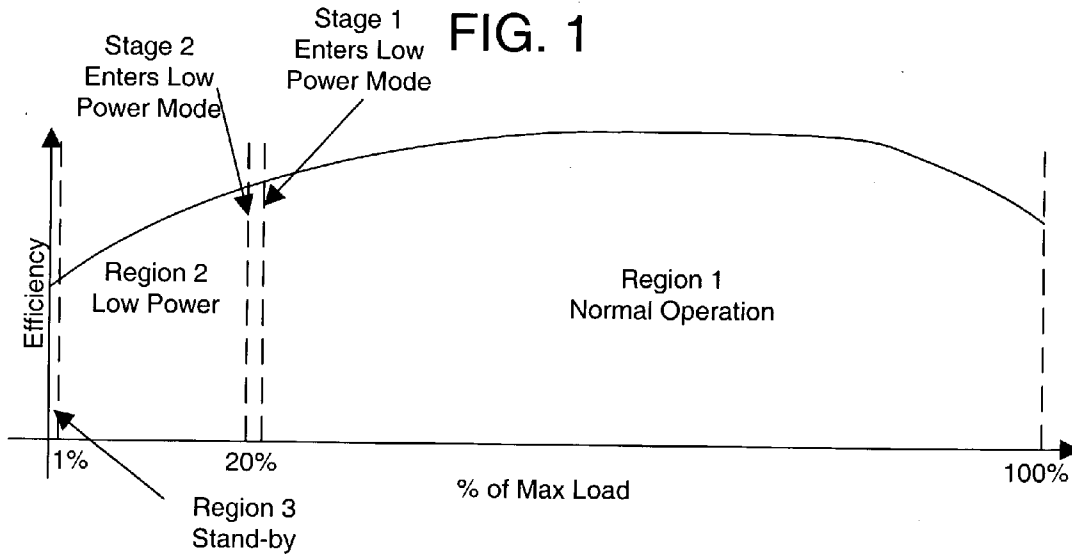

FIG. 2

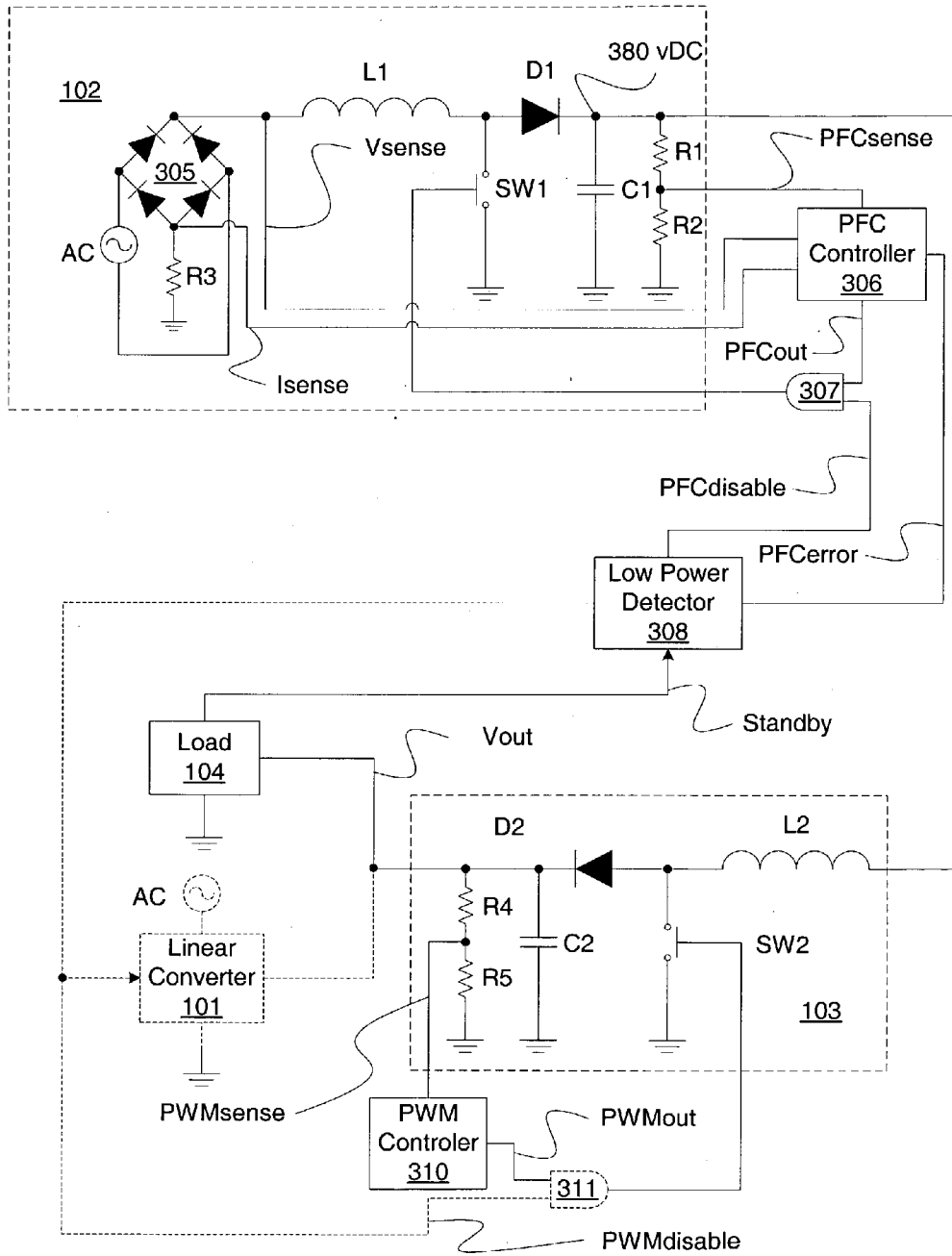

FIG. 3

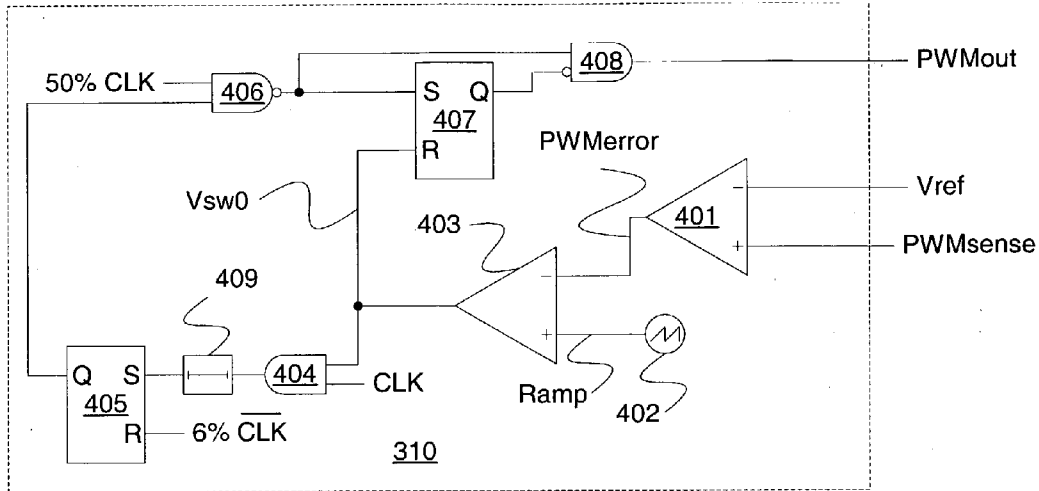

FIG. 4

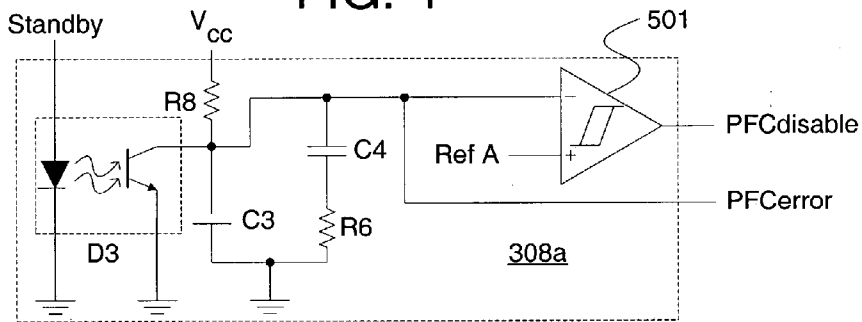

FIG. 5

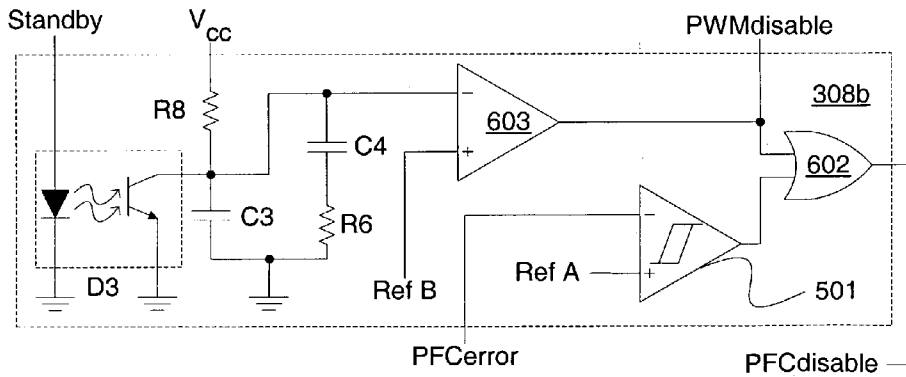
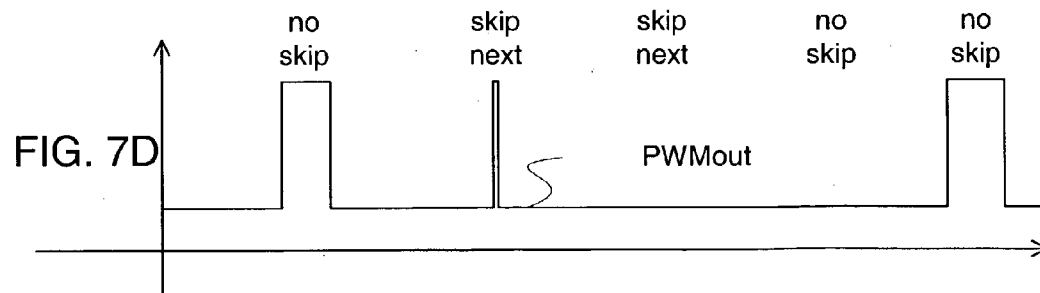
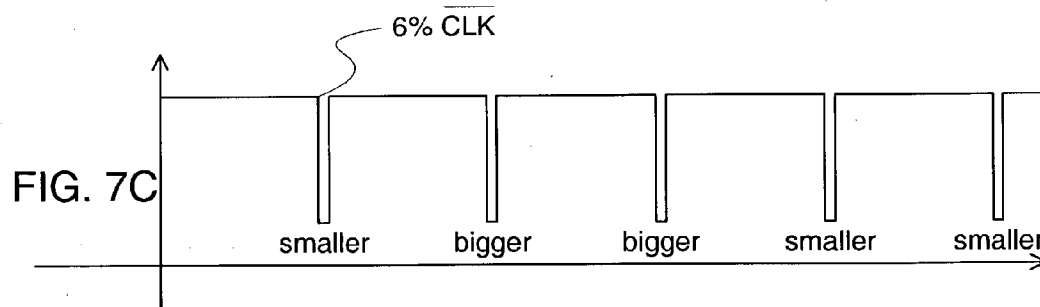
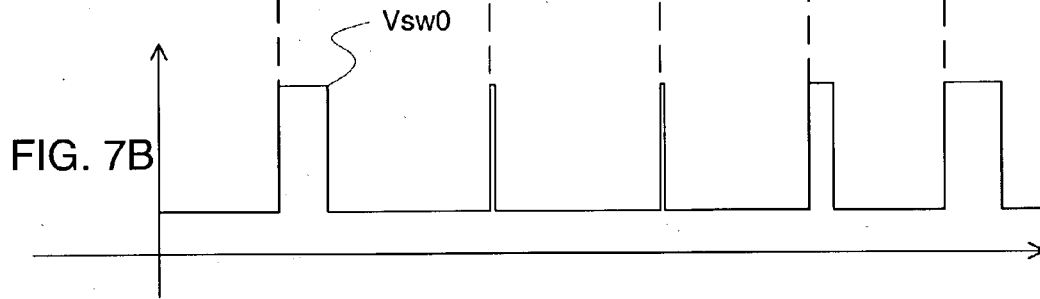
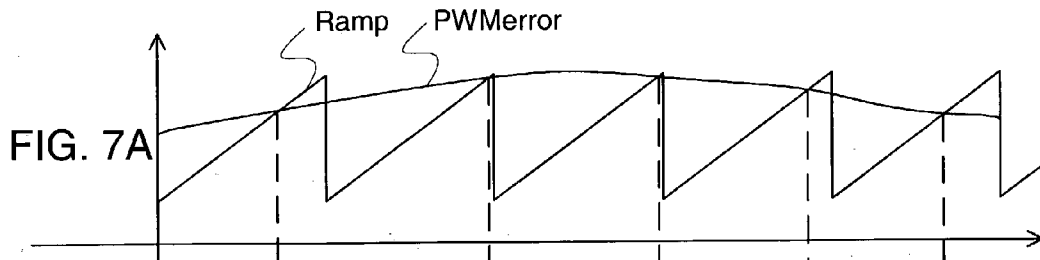

FIG. 6



Explore Litigation Insights

Docket Alarm provides insights to develop a more informed litigation strategy and the peace of mind of knowing you're on top of things.

Real-Time Litigation Alerts



Keep your litigation team up-to-date with **real-time alerts** and advanced team management tools built for the enterprise, all while greatly reducing PACER spend.

Our comprehensive service means we can handle Federal, State, and Administrative courts across the country.

Advanced Docket Research



With over 230 million records, Docket Alarm's cloud-native docket research platform finds what other services can't. Coverage includes Federal, State, plus PTAB, TTAB, ITC and NLRB decisions, all in one place.

Identify arguments that have been successful in the past with full text, pinpoint searching. Link to case law cited within any court document via Fastcase.

Analytics At Your Fingertips



Learn what happened the last time a particular judge, opposing counsel or company faced cases similar to yours.

Advanced out-of-the-box PTAB and TTAB analytics are always at your fingertips.

API

Docket Alarm offers a powerful API (application programming interface) to developers that want to integrate case filings into their apps.

LAW FIRMS

Build custom dashboards for your attorneys and clients with live data direct from the court.

Automate many repetitive legal tasks like conflict checks, document management, and marketing.

FINANCIAL INSTITUTIONS

Litigation and bankruptcy checks for companies and debtors.

E-DISCOVERY AND LEGAL VENDORS

Sync your system to PACER to automate legal marketing.