

# Petitioners' Demonstratives

ASSA ABLOY AB et al., v.  
CPC Patent Technologies PTY LTD.

IPR2022-01093, IPR2022-01094

US Patent No. 8,620,039

November 9<sup>th</sup>, 2023



**I. Overview of the '039 Patent**

**II. Claim Construction: “defining”/“defined by”**

**III. Ground 1: Hsu-Sanford teaches Limitation 1[C]’s defining step**

**IV. Ground 2: Hsu-Sanford-Tsukamura teaches Limitation 1[C]’s defining step**

**V. The Petition Is Not Time Barred**

# I. Overview of the '039 Patent

# '039 Patent: "Card Device Security Using Biometrics"

(12) **United States Patent**  
**Burke**

(10) **Patent No.:** **US 8,620,039 B2**  
(45) **Date of Patent:** **Dec. 31, 2013**

---

(54) **CARD DEVICE SECURITY USING BIOMETRICS**

(56) **References Cited**

U.S. PATENT DOCUMENTS

5,457,747 A	10/1995	Drexler et al.	380/24
6,665,601 B1	12/2003	Nielsen	701/50
6,796,492 B1	9/2004	Gatto	235/379
2004/0041690 A1	3/2004	Yamagishi	340/5

FOREIGN PATENT DOCUMENTS

CA	2 412 403 A1	5/2003
WO	WO 03/036861 A1	5/2003
WO	WO 2004/100053 A1	11/2004

OTHER PUBLICATIONS

International Search Report dated Oct. 20, 2006.  
International Preliminary Report on Patentability dated Nov. 19, 2007.  
Supplementary European Search Report dated Aug. 29, 2011 for EPO Application No. EP 06760981.8.

*Primary Examiner* — Andrew W Johns  
(74) *Attorney, Agent, or Firm* — Brinks Gilson & Lione

(65) **Prior Publication Data**  
US 2010/0296708 A1 Nov. 25, 2010

(21) **Appl. No.:** **12/063,650**  
(22) **PCT Filed:** **Aug. 10, 2006**  
(86) **PCT No.:** **PCT/AU2006/001136**  
§ 371 (c)(1), (2), (4) **Date:** **Aug. 12, 2010**  
(87) **PCT Pub. No.:** **WO2007/019605**  
**PCT Pub. Date:** **Feb. 22, 2007**

(57) **ABSTRACT**

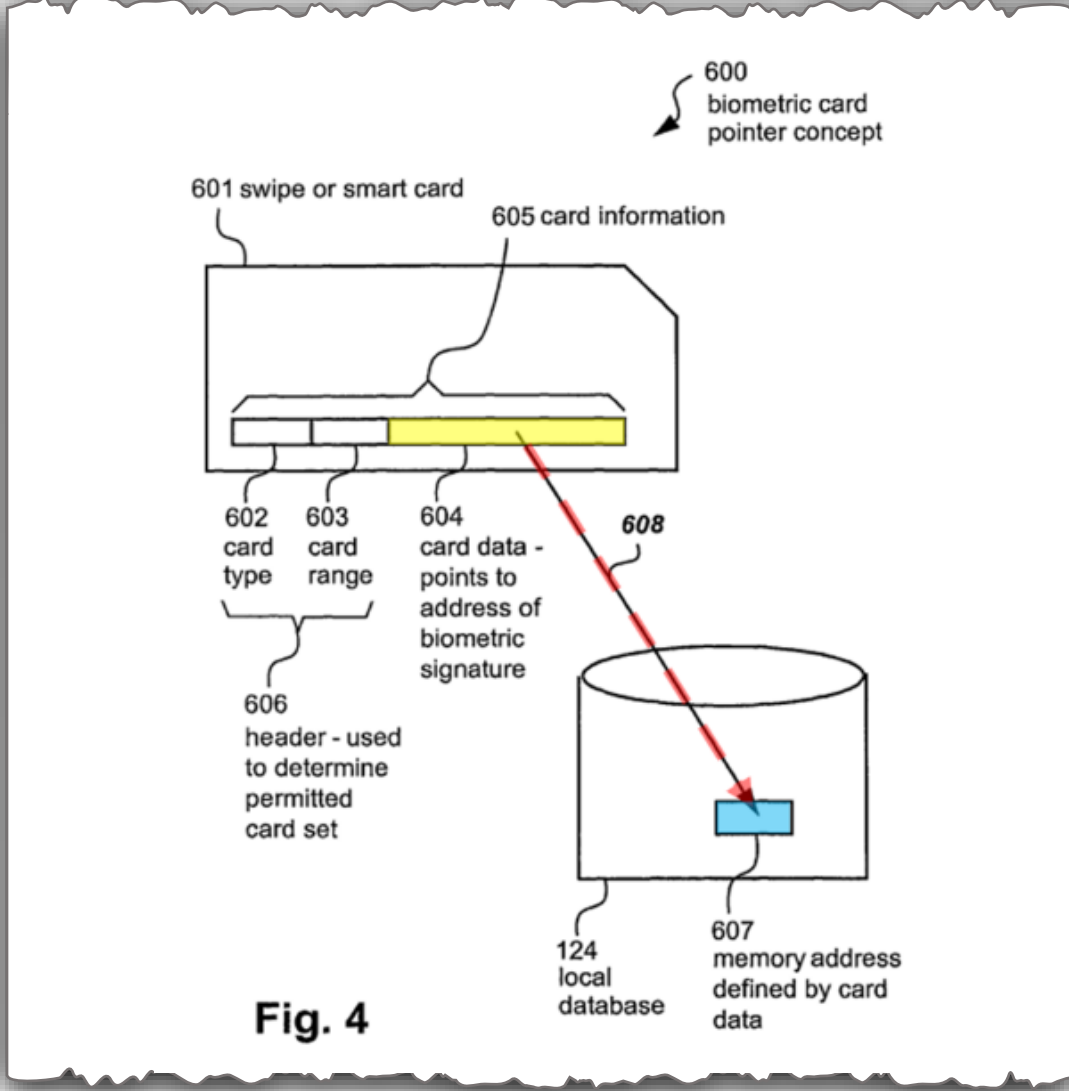

Ex. 1001, Fig. 4 (annotated)

## **II.A Claim Construction:**

**“defining, dependent upon the received card information, a memory location”**

# Claim Construction: '039 Patent Claim 1

## '039 Patent, Claim 1

1[P]	A method of enrolling in a biometric card pointer system, the method comprising the steps of:
1[A]	receiving card information;
1[B]	receiving the biometric signature;
1[C]	<b>defining</b> , dependent upon the received <b>card information</b> , a <b>memory location</b> in a local memory external to the card;
1[D]	determining if the defined memory location is unoccupied; and
1[E]	storing, if the memory location is unoccupied, the biometric signature at the defined memory location.

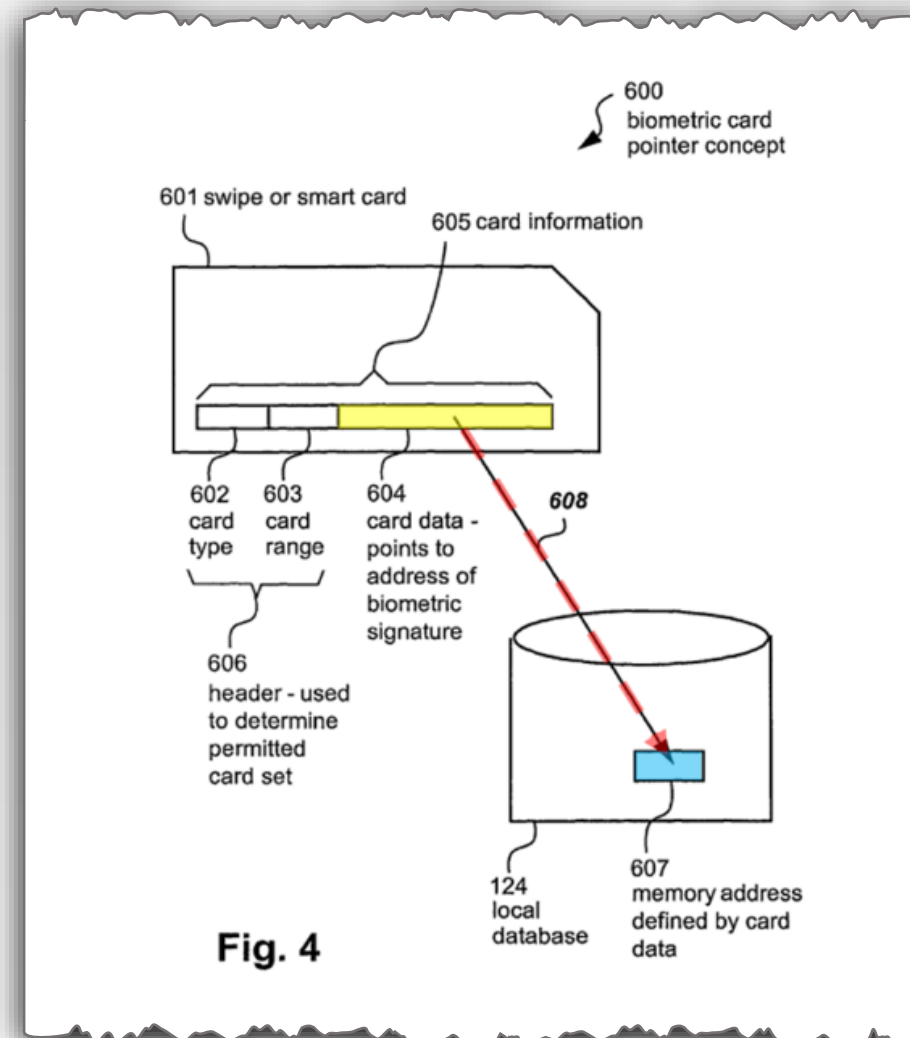

Ex. 1001, Fig. 4 (annotated)

# Claim Construction: '039 Patent Claim 3

## '039 Patent, Claim 3

3[P]	A method of securing a process at a verification station, the method comprising the steps of:
3[A]	(a) providing card information from a card device to a card reader in the verification station;
3[B]	(b) inputting a biometric signature of a user of the card device to a biometric reader in the verification station;
3[C]	(c) determining if the provided card information has been previously provided to the verification station;
3[D(P)]	(d) if the provided card information has not been previously provided to the verification station;
3[D(1)]	(da) storing the inputted biometric signature in a memory at a memory location defined by the provided card information; and
3[D(2)]	(db) performing the process dependent upon the received card information;
3[E(P)]	(e) if the provided card information has been previously provided to the verification station;
3[E(1)]	(ea) comparing the inputted biometric signature to the biometric signature stored in the memory at the memory location defined by the provided card information;
3[E(2)]	(eb) if the inputted biometric signature matches the stored biometric signature, performing the process dependent upon the received card information; and
3[E(3)]	(ec) if the inputted biometric signature does not match the stored biometric signature, not performing the process dependent upon the received card information.

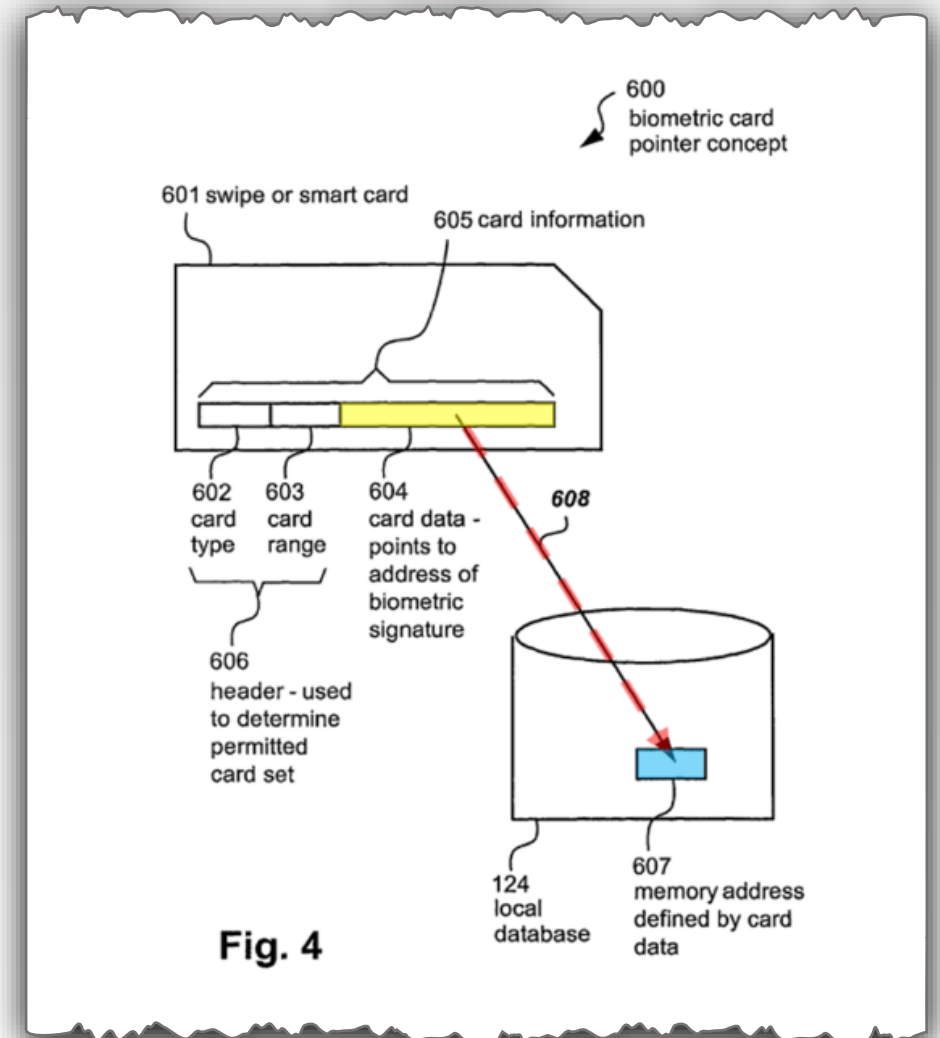

Fig. 4

Ex. 1001, Fig. 4 (annotated)

# '039 Patent's biometric card pointer concept

key fob. In one example of the disclosed BCP approach, the card data 604 acts as the memory reference which points, as depicted by an arrow 608, to a particular memory location at an address 607 in the local database 124 in the verification station 127 of FIG. 3. The fields 602 and 603, which together

Ex. 1001, 7:31-35

earlier enrolment phase. It is also noted that the step 204 reads the contents stored at a single memory address defined by the card data 604 and checks these contents against the biometric signature received in the step 203. There is no need to search the entire database 124 to see if there is a match. Thus the disclosed BCP arrangement provides a particularly simple and fast biometric verification check thereby securing the process associated with the step 205. Once the step 205 has

Ex. 1001, 8:34-41

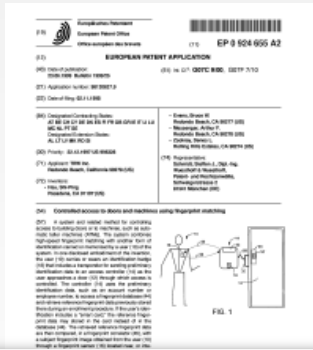

**Ex. 1001  
'039 Patent**

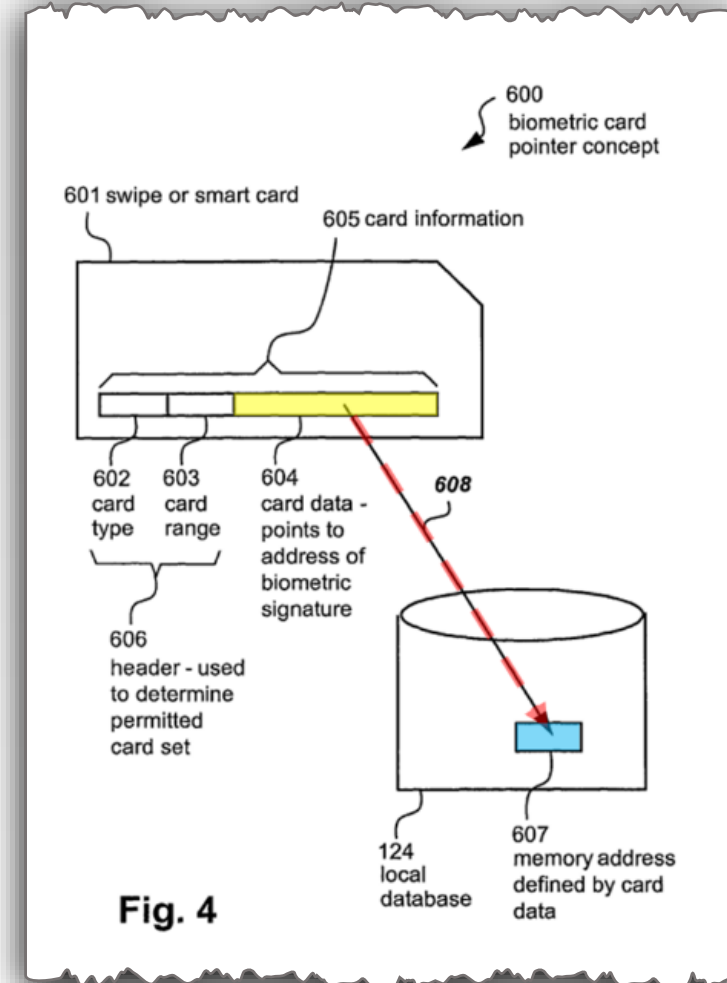

**Fig. 4**

Ex. 1001, Fig. 4 (annotated)



# The primary dispute is over the construction of the “defining” limitation

**ASSA ABLOY**

Petitioner

**Patent Owner’s construction is wrong; and even if it were correct, the claims are still unpatentable over the prior art in the Petition.**

IPR2022-01093, Reply at 5-13

**Petitioners have shown that the claims are unpatentable under any proposed construction.**

IPR2022-01093, Reply 5

## Board's Construction in Apple IPR (Final Written Decision)

The Board's interpretation of the "defining" limitation resolves the disputes in Petitioners' favor.

"Regardless, we can give Patent Owner the benefit of the doubt that during an enrollment process the card data is provided for 'setting' or 'establishing' what memory location, or address, in the local database the fingerprint is to be stored. Even with this understanding, however, ***the card data does not actually create a memory location. The memory location already exists***, it has just not yet been "set" or "established" by the card data as the memory location at which the fingerprint data is stored." (p. 35)

**"If the card data somehow created a memory location, then there would be no reason to determine if the memory location were unoccupied. ... '[t]he only logical use of that term is that *defining means to identify a memory location into which the biometric data is going to be stored.*'"** (p.36)

**"'[t]he only logical use of that term is that *defining means to identify a memory location into which the biometric data is going to be stored.*'"** (p. 35)

"Once the card information and fingerprint is received during enrollment, ***the card information provides data that establishes where, i.e., at what memory location or address, the system will store the fingerprint data.***" (p. 36)

## Board's Construction in Apple IPR (Final Written Decision)

Each of Petitioners' grounds satisfies the Board's construction. The card information "establishes where, i.e., at what memory location or address, the system will store [and retrieve] the fingerprint data."

Just like the database entries in the Apple IPR, the database entries in Hsu satisfy the "defining" limitation. From the Apple IPR final written decision:

*"Once the card is provided during enrollment, **the card information provides data that establishes where, i.e. at what memory location or address, the system is to store the fingerprint data.**"* (p. 36)

*"information on a user's ID card was a known way to define, that is to 'establish' or 'set' a memory location, for example with the user's player ID record entry, where a user's input of a second authenticator, e.g., a fingerprint, would be stored"* (p. 44)

*"When claim 1 is properly interpreted, as we have addressed herein, **the creation of a player account in Bradford, or Foss, prior to receiving the card information does not preclude subsequently identifying a memory location (among preexisting memory locations/addresses within the preexisting player ID database) and establishing that memory location as the location where new biometric data, e.g., a player's fingerprint, is going to be stored.**"* (p. 45)

# Claim Construction: “defining, dependent upon the received card information, a memory location”

**ASSA ABLOY**

Petitioner

**First Construction:** “a memory location is somehow determined from (or is dependent on) the card information... [such that] **the system can look up or otherwise determine** a specific memory location from a user’s card information.”

**Second Construction:** “memory location is specified by the card information itself...[such that] the card information itself must specify the physical memory address where the user’s biometric signature is stored, **without the need to look up** the memory address in a database or other data structure.”

IPR2022-01093, Pet., 11-12; Reply, 6-7

similar  
in scope



Board

**Board’s Preliminary Construction:** “the user’s card information itself specifies the physical memory address (such as by **acting as a pointer**) for the user’s biometric signature.”

IPR2022-01093, Paper 20 (Institution Decision), 38; Reply, 6-7



Patent Owner

**PO’s Construction:** “the system **sets or establishes** a memory location in a local memory external to the card, said location being contingent upon or determined by the received card information.”

IPR2022-01093, Paper 24 (POR), 11

# PO is wrong to construe “defining” to occur *for the first time* during enrollment



Patent Owner

“Limitation 1[C] **cannot be construed** to cover... identifying a memory location that **has already been defined.**”

POR at 13

**ASSA ABLOY**

Petitioner

“PO’s construction contradicts claim 1 itself because if Limitation 1[C]’s defining step sets/establishes **for the first time** the memory location, it would be illogical to **determine whether the memory location is occupied or not (Limitation 1[D])**, since such newly set/established memory location would already be known to be unoccupied.”

Reply at 8

## '039 Patent, Claim 1

1[P]	A method of enrolling in a biometric card pointer system, the method comprising the steps of:
1[A]	receiving card information;
1[B]	receiving the biometric signature;
1[C]	defining, dependent upon the received card information, a memory location in a local memory external to the card;
1[D]	<b>determining if the defined memory location is unoccupied;</b> and
1[E]	storing, if the memory location is unoccupied, the biometric signature at the defined memory location.

# PO's Expert repeatedly admitted that the card information defines the memory location even before the user scans the card at the station



*Patent Owner's Expert  
Samuel Russ*

“Q. **Before that user ever goes up to scan his or her card**, does the card already have on it the information 604 which points to a specific address that is defined by that card information?”

A. Well, the -- the implication is that **the card data has to be there**. Otherwise, it would not know where to store the data...”

Ex. 1031, 70:20-71:1

“Q. **So before the user ever scans his or her card**, the card information 604 **already defines a specific memory location** at which the user's biometric signature data will be stored, correct?”

A. That -- that seems to be what's in the '039 patent, **yes**.

Q. And you're not aware of any contrary teaching or alternative teaching in the '039 patent, correct?”

A. Correct.”

Ex. 1031, 70:20-71:1

# PO's Expert repeatedly admitted that the card information defines the memory location even before the user scans the card at the station



**Patent Owner's Expert**  
*Samuel Russ*

“Q. ... So in the embodiment reflected in Figure 4 of the '039 patent, **the association between card information 604 and memory location 607 exists even before enrollment begins, correct?**”

A. Based on the disclosure and specification associated with Figure 7, **yes.**

Q. What about Figure 4?

A. Yeah, Figure 4 is silent on the subject, but the disclosure in -- associated with Figure 5 and Figure 7 says that, **yes, it occurs prior to.**”

Ex. 1031, 77:15-24

“Q. ... Referring to Figure 4 of the '039 patent, **before a new user ever scans his or her card for the first time**, the card data 604 **already defines a specific memory location** in the database 124, correct?”

THE WITNESS:· That seems to be the case in the '039 patent, **yes.**”

Ex. 1031, 78:2-9

# PO's Expert repeatedly admitted that the card information defines the memory location even before the user scans the card at the station



*Patent Owner's Expert  
Samuel Russ*

“Q. Okay. So I think we already established the memory location 604 on the card **defines a memory location even before the user has ever scanned his or her card**, correct?”

**A. Correct.”**

Ex. 1031, 90:5-9

“ Q... If card data 604 in Figure 4 is a pointer to a specific memory address in database 124, then **the memory address has already been defined prior to the user scanning his or her card at the system**, correct?”

**A. Correct.”**

Ex. 1031, 78:2-9

Therefore, the memory address is **not set/established for the first time during enrollment** as PO contends.

Reply at 7-8



# Claim Construction: “defining, dependent upon the received card information, a memory location”

**ASSA ABLOY**

Petitioner

“Up until claim 1’s determining step, the current process may be either an enrollment or verification process... In other words,... the defining step in Limitation 1[C] is performed during **both enrollment and verification.**”

Reply at 9

## '039 Patent, Claim 1

1[P]	A method of enrolling in a biometric card pointer system, the method comprising the steps of:
1[A]	receiving card information;
1[B]	receiving the biometric signature;
1[C]	defining, dependent upon the received card information, a memory location in a local memory external to the card;
1[D]	determining if the defined memory location is unoccupied; and
1[E]	storing, if the memory location is unoccupied, the biometric signature at the defined memory location.

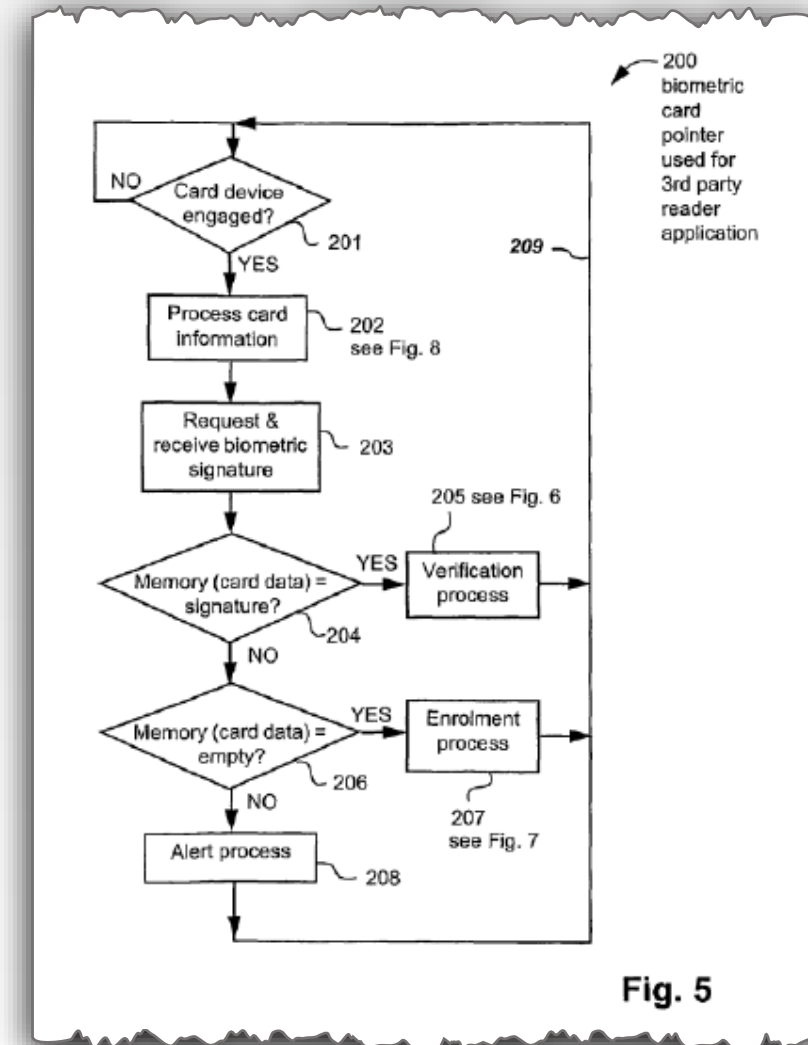

Ex. 1001, Fig. 5

# '039 Patent never mentions setting/establishing “for the first time”

**ASSA ABLOY**  
Petitioner

“When discussing the only graphical representation of the relationship between the card information and the memory location, *i.e.*, Figure 4..., the '039 Patent states that “[t]he card data 604 defines the location 607 in the memory 124 where their unique biometric signature is stored”..., but never mentions that such association is set/established **for the first time** during enrollment, *e.g.*, a user may store his/her fingerprint at a previously reserved/established memory location.”

Reply at 10

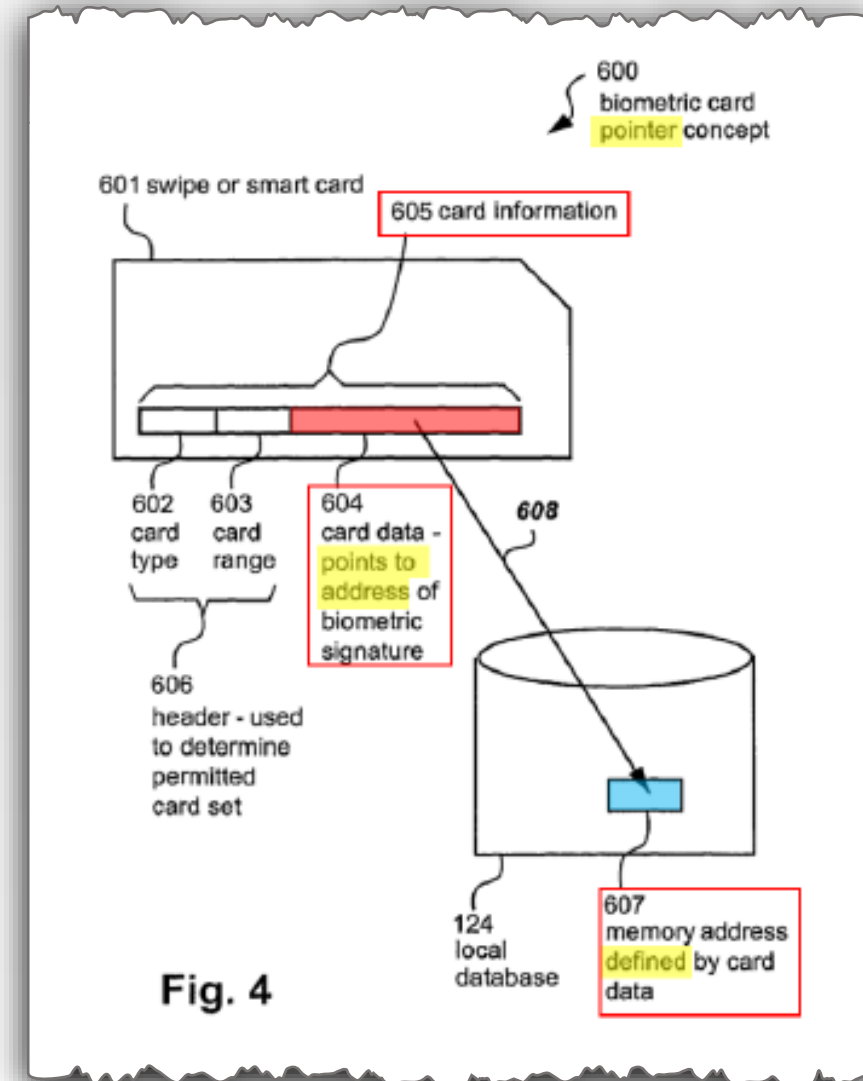

Ex. 1001, Fig. 4

# Claim Construction: “defining, dependent upon the received card information, a memory location”



“[A] claim construction that would exclude the preferred embodiment “is rarely, if ever, correct and would require highly persuasive evidentiary support.”

*Rexnord Corp. v. Laitram Corp.*, 274 F.3d 1336, 1342 (Fed. Cir. 2001)  
(citing *Vitronics Corp. v. Conceptronic, Inc.*, 90 F.3d 1576, 1583 (Fed.Cir.1996))

## **II.B Claim Construction:**

**“memory location defined by the provided card information”**

# Claim Construction: '039 Patent Claim 3

## '039 Patent, Claim 3

3[P]	A method of securing a process at a verification station, the method comprising the steps of:
3[A]	(a) providing card information from a card device to a card reader in the verification station;
3[B]	(b) inputting a biometric signature of a user of the card device to a biometric reader in the verification station;
3[C]	(c) determining if the provided card information has been previously provided to the verification station;
3[D(P)]	(d) if the provided card information has not been previously provided to the verification station;
3[D(1)]	(da) storing the inputted biometric signature in a memory at a <b>memory location defined by the provided card information</b> ; and
3[D(2)]	(db) performing the process dependent upon the received card information;
3[E(P)]	(e) if the provided card information has been previously provided to the verification station;
3[E(1)]	(ea) comparing the inputted biometric signature to the biometric signature stored in the <b>memory at the memory location defined by the provided card information</b> ;
3[E(2)]	(eb) if the inputted biometric signature matches the stored biometric signature, performing the process dependent upon the received card information; and
3[E(3)]	(ec) if the inputted biometric signature does not match the stored biometric signature, not performing the process dependent upon the received card information.

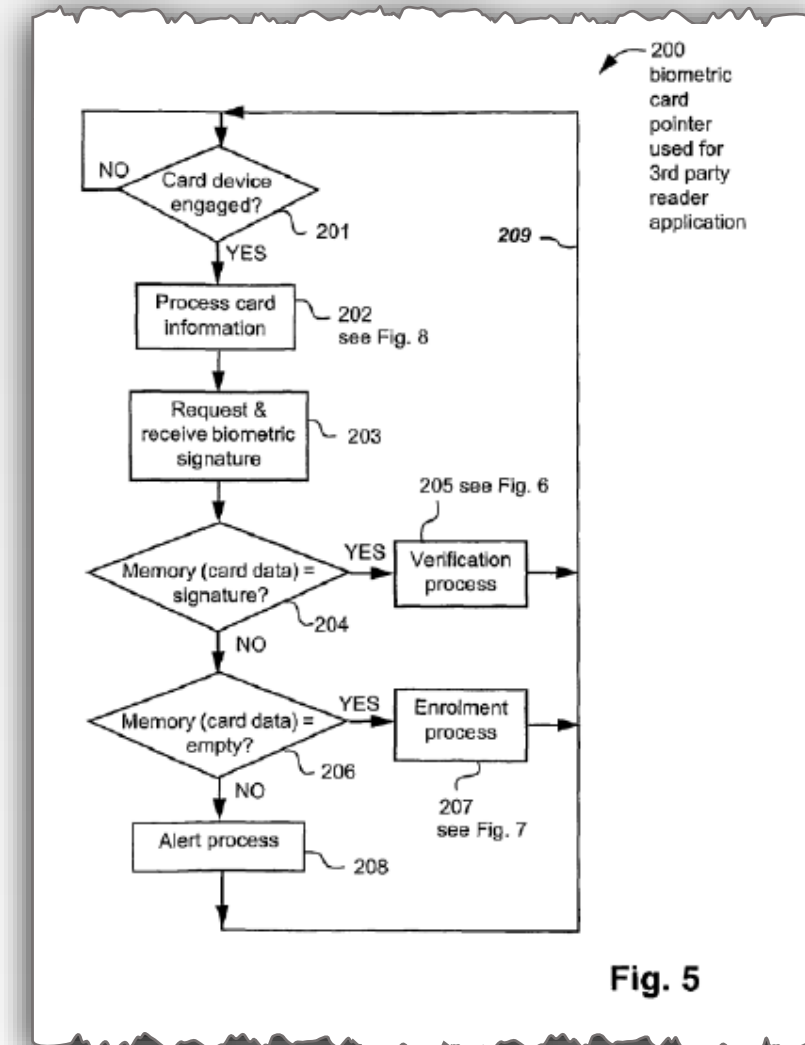

Fig. 5

Ex. 1001, Fig. 5

# The primary dispute is over the construction of the “defining” limitation

**ASSA ABLOY**

Petitioner

**Patent Owner’s construction is wrong; and even if it were correct, the claims are still unpatentable over the prior art in the Petition.**

IPR2022-01094, Reply at 5-12

**Petitioners have shown that the claims are unpatentable under any construction.**

IPR2022-01094, Reply at 5

# In Claim 3, “defined by” is recited the same for both enrollment and verification

**ASSA ABLOY**

Petitioner

“Unlike claim 1, claim 3 does not even recite any ‘defining’ step... Limitation 3[D(1)] merely requires ‘storing the inputted biometric signature in a memory at a memory location **defined by** the provided card information,’ and does not require **when** the defining of the memory location happens.”

IPR2022-01094, POR at 8



Patent Owner

“[T]he plain language of claim 3 itself establishes that the ‘defined’ step occurs during enrollment, not verification.”

IPR2022-01094, Sur-Reply at 3

# In Claim 3, “defined by” is recited the same for both enrollment and verification



*Petitioners' Expert  
Stuart Lipoff*

“PO is wrong to interpret Limitation 3[D(1)] differently from Limitation 3[E(1)] such that Limitation 3[D(1)]’s “defined by...” requires setting/establishing **for the first time** the memory location for storing the fingerprint data while Limitation 3[E(1)] does not.”

IPR2022-01094, Ex. 1032, ¶ 11



*Patent Owner's Expert  
Samuel Russ*

“A. ... however the connection, in whatever sense the defining step occurs in 3[D(1)], the **same defining step** occurs in 3[E(1)].”

Ex. 1031, 54:1-3

“Q. ... do you interpret the language ‘defined by the provided card information’ to be the same in limitation 3[E(1)] and 3[D(1)]?”

\* \* \*

THE WITNESS: **Yes...**”

Ex. 1031, 54:17-21



# PO's Expert admits that "defined by" is recited for both enrollment and verification



**Patent Owner's Expert**  
*Samuel Russ*

**Q. In both enrollment and verification** within Claim 3, the recitation is that the [] provided card information defines the memory location; is that correct?

A. In -- yes, it's used to store in 3D and to compare in 3E. And, yes, in both cases the "defined by" language appears.

Q. And so in both cases, is it your understanding that the provided card information defines the memory location?

**A. In both places the provided card information defines the memory location..."**

Ex. 1031, 55:22-56:8

## '039 Patent, Claim 3

3[P]	A method of securing a process at a verification station, the method comprising the steps of:
3[A]	(a) providing card information from a card device to a card reader in the verification station;
3[B]	(b) inputting a biometric signature of a user of the card device to a biometric reader in the verification station;
3[C]	(c) determining if the provided card information has been previously provided to the verification station;
3[D(P)]	(d) if the provided card information has not been previously provided to the verification station;
3[D(1)]	(da) storing the inputted biometric signature in a memory at a <b>memory location defined by the provided card information;</b> and
3[D(2)]	(db) performing the process dependent upon the received card information;
3[E(P)]	(e) if the provided card information has been previously provided to the verification station;
3[E(1)]	(ea) comparing the inputted biometric signature to the biometric signature stored in the <b>memory at the memory location defined by the provided card information;</b>
3[E(2)]	(eb) if the inputted biometric signature matches the stored biometric signature, performing the process dependent upon the received card information; and
3[E(3)]	(ec) if the inputted biometric signature does not match the stored biometric signature, not performing the process dependent upon the received card information.

# II.C Claim Construction: “method of enrolling”

# “Method of enrolling” is non-limiting preamble language

## '039 Patent, Claim 1

1[P]	A <b>method of enrolling</b> in a biometric card pointer system, the method comprising the steps of:
1[A]	receiving card information;
1[B]	receiving the biometric signature;
1[C]	defining, dependent upon the received card information, a memory location in a local memory external to the card;
1[D]	determining if the defined memory location is unoccupied; and
1[E]	storing, if the memory location is unoccupied, the biometric signature at the defined memory location.

# Claim Construction: “method of enrolling”



“[A] **preamble is not limiting** ‘where a patentee defines a structurally complete invention in the claim body and uses the preamble only to state a purpose or **intended use** for the invention.’”

*Catalina Mktg. Int'l, Inc. v. Coolsavings.com, Inc.*, 289 F.3d 801, 808 (Fed. Cir. 2002)  
(citing *Rowe v. Dror*, 112 F.3d 473, 478 (Fed.Cir.1997))

# Claim Construction: “method of enrolling”

**ASSA ABLOY**

Petitioner

“Claim 1 both  
(i) defines a **structurally complete** invention by starting with ‘receiving card information/biometric signature’ and concluding with ‘storing... the biometric signature’... and  
(ii) its preamble of a “method of enrolling” is nothing more than a non-limiting **intended use.**”

Reply at 13

## '039 Patent, Claim 1

1[P]	A <b>method of enrolling</b> in a biometric card pointer system, the method comprising the steps of:
1[A]	receiving card information;
1[B]	receiving the biometric signature;
1[C]	defining, dependent upon the received card information, a memory location in a local memory external to the card;
1[D]	determining if the defined memory location is unoccupied; and
1[E]	storing, if the memory location is unoccupied, the biometric signature at the defined memory location.

Therefore, “defining” is not limited to enrollment.

# III. Ground 1: Hsu-Sanford teaches Limitation 1[C]’s defining step

# Hsu-Sanford teaches Limitation 1[C]’s defining step

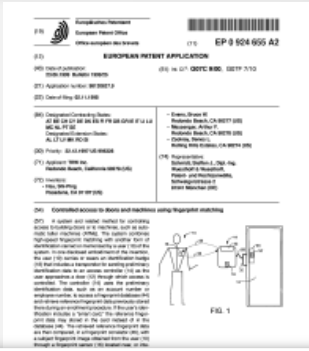

**Ex. 1003  
Hsu**

at this stage. The account number is stored in the database 44 in association with the user’s fingerprint image data. The fingerprint correlator 46 described in the pat-

Ex. 1003 (Hsu), ¶ 26

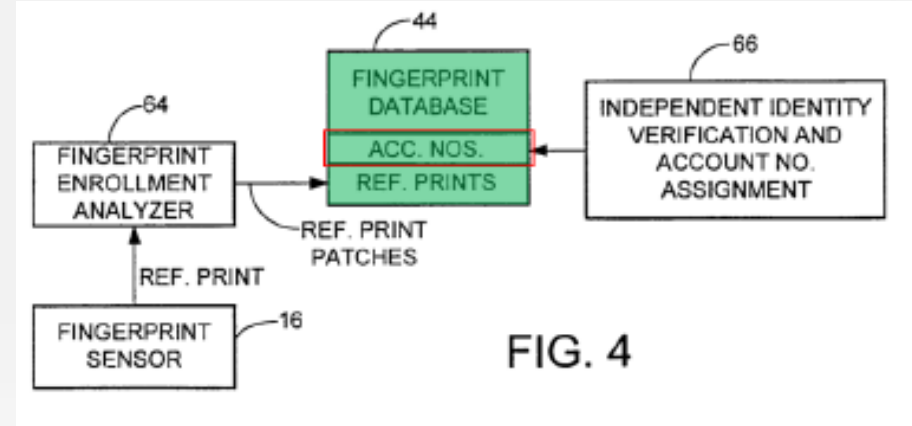

Ex. 1003 (Hsu), Fig. 4 (annotated)

**ASSA ABLOY**  
Petitioner

“Although Hsu is silent on how a new user record is created, it would have been obvious for a POSITA to try using simple, known options for creating database records.

**One option** is to store all the user numbers in Hsu’s database and reserve/pre-establish memory locations for associated fingerprint data...

Discloses Limitation 1[C]’s “defining” step under **Petitioners’ First Construction and the Board’s construction.**

**Another option** is to create a new user record on enrollment.”

Discloses Limitation 1[C]’s “defining” step under **Patent Owner’s construction.**

Reply at 16-17; Ex. 1032, ¶¶ 32-34

# Hsu-Sanford teaches Limitation 1[C]’s defining step under Petitioners’ First Construction and the Board’s Preliminary Construction

**ASSA ABLOY**

Petitioner



Board

**First Construction:** “a memory location is somehow determined from (or is dependent on) the card information... [such that] **the system can look up or otherwise determine a specific memory location from a user’s card information.**”

IPR2022-01093, Pet., 11-12; Reply, 6-7

**Board’s Preliminary Construction:** “the user’s card information itself specifies the physical memory address (such as by **acting as a pointer**) for the user’s biometric signature.”

IPR2022-01093, Paper 20 (Institution Decision), 38; Reply, 6-7

similar  
in scope

**ASSA ABLOY**

Petitioner

“**One option** is to store all the user numbers in Hsu’s database and reserve/pre-establish memory locations for associated fingerprint data. **Upon a user enrolling by providing a user number, the system looks up the user number and determines the corresponding memory location for storing the user’s fingerprint,** which discloses Limitation 1[C]’s ‘defining’ step under Petitioners’ First Construction and the Board’s construction.”

Reply at 16-17; Ex. 1032, ¶¶ 32-33



# Hsu-Sanford teaches Limitation 1[C]’s defining step under PO’s Construction



Patent Owner

**PO’s Construction**: “the system **sets or establishes** a memory location in a local memory external to the card, said location being contingent upon or determined by the received card information.”

IPR2022-01093, Paper 24 (POR), 11

**ASSA ABLOY**

Petitioner

“**Another option** is to create a new user record on enrollment... **Upon a user enrolling, she would provide a previously unseen card/user number, and the system would then create a new record for the user, including setting/establishing for the first time the memory location for storing the user’s fingerprint.**”

Reply at 17; Ex. 1032, ¶ 34

# Timing: PO presents its claim construction for the first time in its POR



Board

“At this preliminary stage of the proceeding we acknowledge that Patent Owner has **not yet provided any substantive claim construction** in its Preliminary Response. **Both parties will have the opportunity to address** this matter in additional briefing, including in Patent Owner’s Response and **Petitioner’s Reply.**”

IPR2022-01093, Paper 20 (Institution Decision), 38



Patent Owner

“‘Defining,’ as used in the Challenged Claims, does not (and cannot) mean merely looking up or identifying something that has already been defined.”

POR at 11

“[A] POSITA would interpret the word ‘defining,’ especially in the context of enrollment, to mean ‘setting’ or ‘establishing.’”

POR at 12

# Timing: Petitioners are permitted to rebut PO's new claim construction arguments



Board

“The **patent owner** may then respond to these positions and/or **propose additional terms for construction...**The petitioner may respond to any such new claim construction issues raised by the **patent owner**, but cannot raise new claim construction issues that were not previously raised in its petition.”

*Patent Trial and Appeal Board Consolidated Trial Practice Guide (Nov. 2019), 44-45*



Patent Owner

“Petitioners offer **two new theories** as to how Hsu-Sanford allegedly teaches Limitation 1[C]’s defining step under PO’s construction... **These new arguments are untimely and should be disregarded.**”

Sur-reply at 14

# Timing: Petitioners are permitted to rebut PO's new claim construction arguments

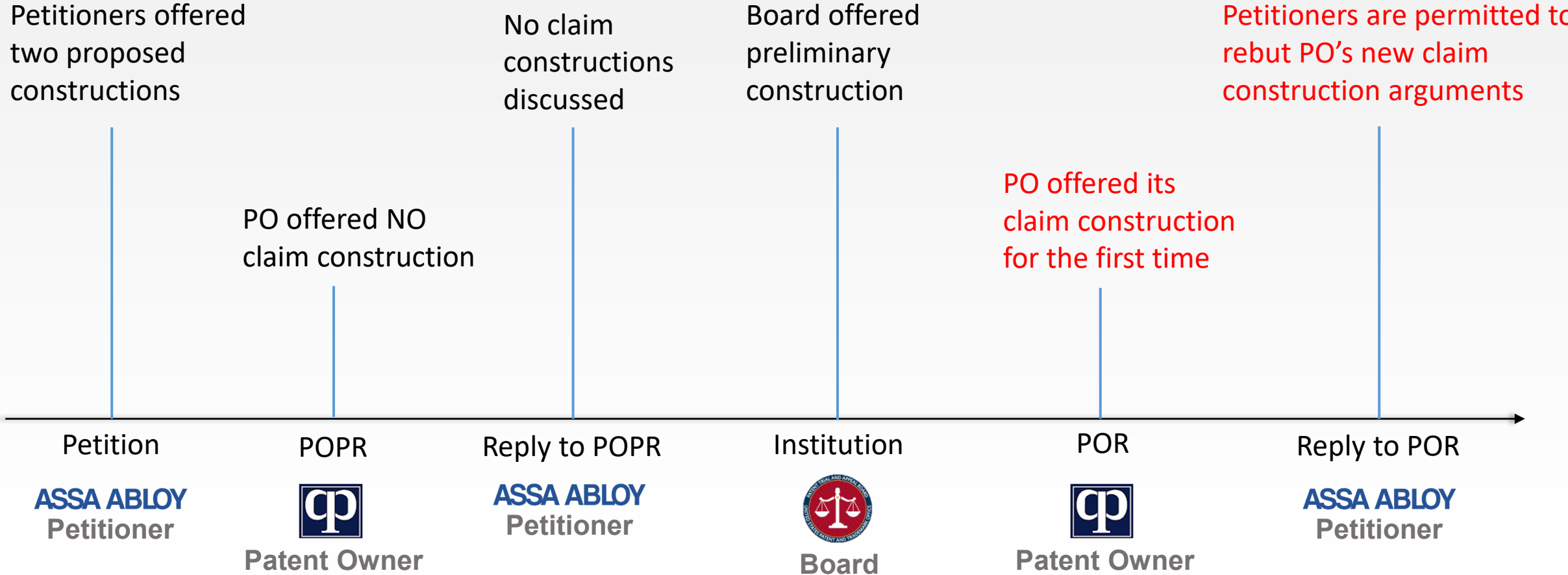

# Timing: Petitioners are permitted to rebut PO's new claim construction arguments



“Barring argument and evidence in a reply directed to a new claim construction proposed by the patent owner would create opportunities for sandbagging by the patent owner in order to create an estoppel.”

*Axonics, Inc. v. Medtronic, Inc.*, No. 2022-1532, 2023 WL 5006851, at \*8 (Fed. Cir. Aug. 7, 2023)

## **IV. Ground 2: Hsu-Sanford-Tsukamura teaches Limitation 1[C]’s defining step**

# Hsu-Sanford-Tsukamura teaches Limitation 1[C]'s defining step

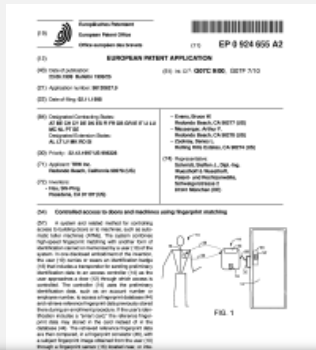

**Ex. 1005  
Tsukamura**

The collation controller 34 extracts the feature points of fingerprint (central or branch point of fingerprint pattern) from the fingerprint image data D37 to produce a fingerprint template Temp. And the collation controller 34 registers the fingerprint template Temp and an attribute Attb associated with the fingerprint template Temp at an index (address) specified by the index number N index within the collation flash ROM 35, as shown in FIG. 3, and notifies the personal computer 10 that the registration of fingerprint has been completed (FIG. 1).

Ex. 1005 (Tsukamura), 3:28-34

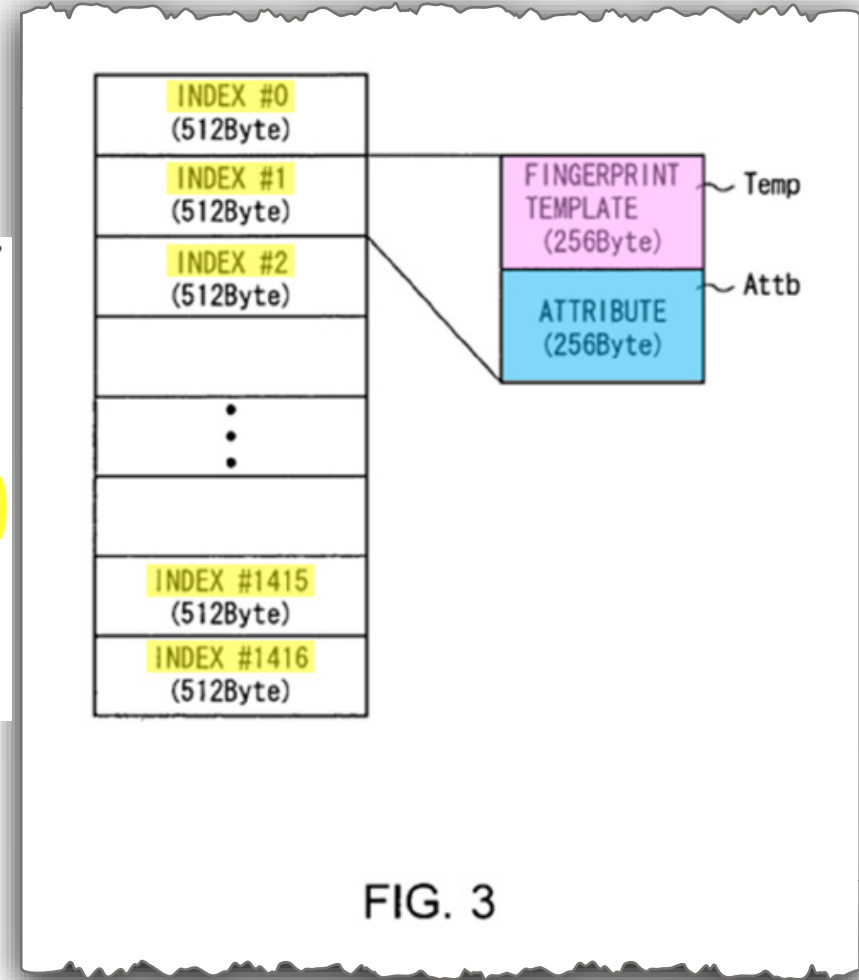

FIG. 3

Ex. 1005, Fig. 3 (annotated)

# PO's purported deficiencies regarding Tsukamura are irrelevant



Patent Owner

“[T]here is **no teaching or suggestion** in Tsukamura that **the IC card 21** defines or provides information about where to store the biometric signature during enrollment or otherwise.”

POR at 22

“This, however, has **no bearing on the unpatentability analysis** because the Petition **does not rely on Tsukamura's IC card 21** for disclosing the claimed 'card information.' Tsukamura is relied on under Ground 2 solely for its memory configuration... As explained in the Petition, it would have been obvious to **assign Tsukamura's index number as the user/account/employee number** in the Hsu-Sanford system.”

ASSA ABLOY

Petitioner

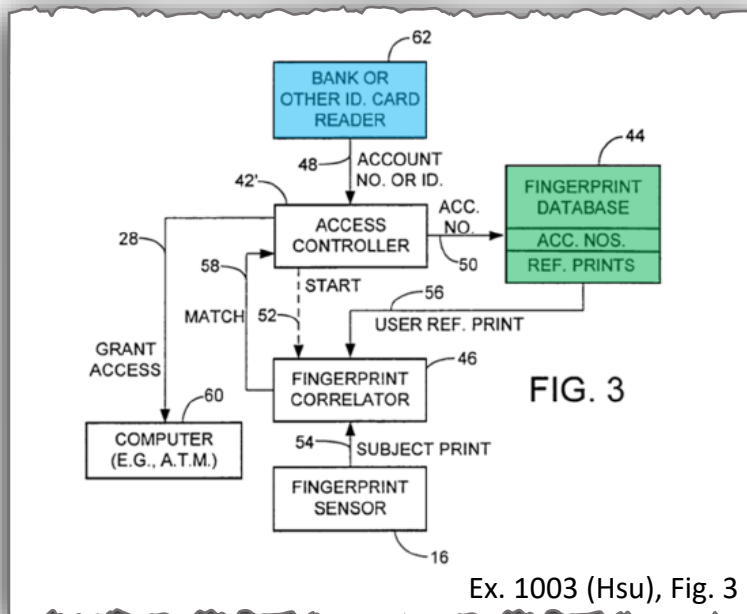

Ex. 1003 (Hsu), Fig. 3

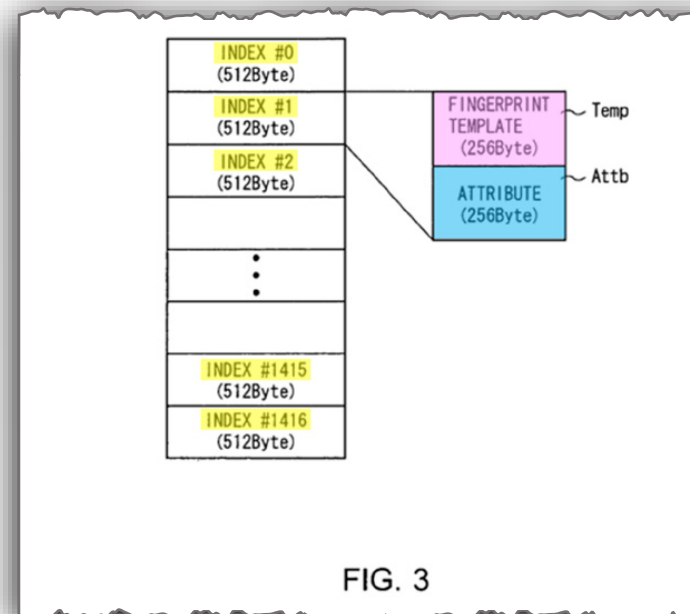

FIG. 3

Reply at 17-18

Ex. 1005 (Tsukamura), Fig. 5



# PO's purported deficiencies regarding Tsukamura are irrelevant



Patent Owner

“A POSITA would have understood that the indexed-based numbering system of Tsukamura is **fundamentally different** than the pointer-based system disclosed in the '039 Patent... For example, the pointer system of the **'039 Patent** is more flexible and **permits database records of varying sizes**, while the index system of **Tsukamura** is more rigid and only works if the **database records are of uniform size.**”

POR at 23

**ASSA ABLOY**

Petitioner

“**Not so...**Just like the '039 Patent's card information, **Tsukamura's index number acts as a pointer to a specific memory location** for storing the fingerprint, and a POSITA would have understood that Tsukamura discloses a pointer system.”

Reply at 18

“[A]s Dr. Russ admits, none of the Challenged Claims require flexibility of storing records of varying sizes.”

Reply at 19

# PO's expert admits that none of the challenged claims require flexibility of storing records of varying sizes



*Patent Owner's Expert  
Samuel Russ*

“Q. Are you aware of anywhere in the ‘039 patent where it describes that the fingerprint records are of variable size?”

A. I'm **not aware** of where the ‘039 patent discloses it...”

Ex. 1031, 123:17-21

“Q. Are you aware of anywhere in any claim of the ‘039 patent where it matters whether the memory locations for users are of the same size or of variable size?”

\* \* \*

THE WITNESS: I think **the claims of the ‘039 patent are silent** on the subject...”

Ex. 1031, 123:23-124:4

“Q. Do any of the '039 patent claims require the memory location being able to store records of varying sizes?”

A. Well, **the ‘039 patent is silent** on the subject...”

Ex. 1031, 124:16-20

# A POSITA would have been motivated to combine Hsu-Sanford with Tsukamura



Patent Owner

“[T]he indexing system of Tsukamura was **unsuitable** for fingerprint storage because it relies on **fixed-size records**... [F]ingerprint data for different individuals will **vary in size**, largely because individuals have different numbers of fingerprint ‘minutiae.’”

Sur-reply at 17-18

**ASSA ABLOY**

Petitioner

“[W]hile **Tsukamura’s** indices point to memory locations that are 512 bytes apart, records stored at these memory locations **need not be ‘of identical size’**—any record no greater than 512 bytes can be stored.”

Reply at 21

“Regardless, the Challenged Claims **do not require any particular type of** memory configuration.”

Reply at 21

# The law does not require the combination be the “best option”



“Our caselaw is clear. It’s not necessary to show that a combination is ‘the *best* option, only that it be a *suitable* option.’”

*Intel Corp. v. Qualcomm Inc.*, 21 F.4th 784, 800 (Fed. Cir. 2021) (emphasis original)  
(citing *PAR Pharm., Inc. v. TWI Pharms., Inc.*, 773 F.3d 1186, 1197–98 (Fed. Cir. 2014))

# Replacing Hsu's database with Tsukamura's memory configuration is a "suitable option"



Patent Owner



*Patent Owner's Expert  
Samuel Russ*

"**Three extremely common solutions** to data storage are (and were at the time of the '039 Patent invention), first, to have a **searchable database of records [Hsu]**, second, to structure the storage as an **array of records of fixed size [Tsukamura]**..."

POR at 26-27

"Q. Can you briefly summarize what each of these **three common solutions** for data storage are?

A. ... a searchable database of records, an array of records of fixed size, and having pointers to the records.

Q. **Each of these types of data storage were well-known** before the time '039 patent application; is that correct?

A. **I believe that's correct, yes.**"

Ex. 1031, 12:25-13:8

"A. Yes, a searchable database of records, an array of records of fixed size, and an unstructured collection of records having pointers to **each were all well-known ways** even prior to 2000."

Ex. 1031, 16:17-20

# Tsukamura's array is not undesirable



Patent Owner

“[I]t was known in the art that **fingerprint data may be of variable Size**... A fixed-size indexing system [such as Tsukamura], therefore, would have been undesirable.”

POR at 26



*Petitioners' Expert*  
*Stuart Lipoff*

“**[S]toring the raw fingerprint images (e.g., as bit map of pixels)** was a well known way to store fingerprint data. Hsu discloses storing “fingerprint image[s]” captured from the same sensor..., which a POSITA would have understood as being of the **same or similar size**.”

Ex. 1032, ¶ 51

“Tsukamura also teaches “collat[ing] the **fingerprint image data**,” which are also expected to have a **similar size for different individuals**.”

Ex. 1032, ¶ 51

# PO's Expert admits that the '039 Patent does not require a specific type of biometric signature



***Patent Owner's Expert  
Samuel Russ***

“Q. Is there any mention in the '039 patent that you're aware of specifying the format in which a user's biometric signature data is to be stored?”

A. No...”

Ex. 1031, 130:16-19

“Q. Do you believe that the '039 patent is limited to the context of fingerprint data for the biometric data that's stored in memory?”

A. No.”

Ex. 1031, 133:16-19

# Hsu's database is not more advantageous than Tsukamura's array with respect to the ability to store variable-size records



*Petitioners' Expert  
Stuart Lipoff*

“[A] POSITA would have understood that, **like Tsukamura, Hsu cannot store data entries of any size in its database either.** For example, MySQL is one of the most common database technologies and is based on fixed-length records. As shown below, **when creating a table in MYSQL, the data type and max length for each column needs to be specified.**”

Ex. 1032, ¶ 58

Use a CREATE TABLE statement to specify the layout of your table:

```
mysql> CREATE TABLE pet (name VARCHAR(20), owner VARCHAR(20),  
-> species VARCHAR(20), sex CHAR(1), birth DATE, death DATE);
```

Ex. 1039, p. 2 (annotated)



# Tsukamura's array has advantages over Hsu's database



Patent Owner

“When user records are structured as a **database**,... [t]his... has the possible **disadvantage of an extended search time**, or at least a search time that grows larger as the file grows larger.”

POR at 27



*Petitioners' Expert*  
*Stuart Lipoff*

“**Tsukamura addresses this exact problem in Hsu...** [W]hen storing/retrieving the fingerprint associated with a particular user, Tsukamura does not need to perform a database look-up like Hsu, but rather **can write/read directly to/from the memory location defined by the index number**, which is faster than writing/reading to/from Hsu's database.”

Ex. 1032, ¶ 60

“[E]ven if some space in memory was unused due to variable sizes of fingerprint records, the **increased speed** of access of the implementation may well have **outweighed** a small amount of **unused memory** (such when memory is relatively cheap to purchase but the requirement for access speed is high).”

Ex. 1032, ¶ 60

# V. The Petition Is Not Time Barred

# The Petitions Were Not Filed At Apple's Behest

- Apple does not direct, control, fund, or contribute to these Petitions.
- “Petitioners have not had any communications with Apple, directly or through counsel, regarding [the IPRs], other than...seeking Apple’s permission to produce documents...”

Ex-1023, Petitioners ROG Responses

# Apple and Petitioners Have A Standard Business Relationship

- Apple's click-through application developer agreement has been accepted by 34 million Apple business partner
- Apple does not direct, control, fund, or contribute to these Petitions

# Developer Agreement Does Not Support RPI

- Developer Agreement merely requires representation and warranty “to the best of [the subscriber’s] knowledge and belief,” whether rights are clear for use
- Does not require the subscriber to take any action
- Subscriber is not required to make any legal review of allegedly infringing patents

# Sending Products for Compliance/Certification

- CPC cites no authority that compliance testing makes Apple an RPI
- Apple requires all MFi (“Made for iPhone/iPod/iPad”) certified products be submitted for compliance testing

# CPC's "Clear Beneficiary" Argument Is Meritless

- Apple filed its IPRs months *before* Petitioners
- Apple's own IPRs were instituted

# Apple Is Not In Privity with Petitioners

- No agreement binds Petitioners to the Apple action
- No privity in business relationship between Apple and Petitioners
- Petitioners have no control or representation in the Apple action.
- Petitioners are not acting as Apple's proxy