



US006144711A

**United States Patent** [19]  
**Raleigh et al.**

[11] **Patent Number:** **6,144,711**  
[45] **Date of Patent:** **Nov. 7, 2000**

[54] **SPATIO-TEMPORAL PROCESSING FOR COMMUNICATION**

[75] Inventors: **Gregory G. Raleigh**, El Granada;  
**Vincent K. Jones, IV**, Redwood Shores; **Michael A. Pollack**, Cupertino, all of Calif.

[73] Assignee: **Cisco Systems, Inc.**, San Jose, Calif.

[21] Appl. No.: **08/921,633**

[22] Filed: **Aug. 27, 1997**

**Related U.S. Application Data**

[60] Provisional application No. 60/025,227, Aug. 29, 1996, and provisional application No. 60/025,228, Aug. 29, 1996.

[51] **Int. Cl.<sup>7</sup>** ..... **H04L 1/02**  
[52] **U.S. Cl.** ..... **375/347; 375/346; 375/349**  
[58] **Field of Search** ..... 375/219, 260, 375/316, 346, 347, 348, 285, 349, 350; 370/342, 203, 210; 455/63, 64, 65; 708/403, 404, 405

[56] **References Cited**

**U.S. PATENT DOCUMENTS**

4,337,376	6/1982	Gruenberg	179/2 EB
4,710,944	12/1987	Nossen	375/40
5,134,715	7/1992	Parl et al.	455/64
5,228,025	7/1993	Le Floch et al.	370/20
5,315,584	5/1994	Savary et al.	370/18
5,345,599	9/1994	Paulraj et al.	455/49.1
5,471,647	11/1995	Gerlach et al.	455/63
5,479,444	12/1995	Malkamaki et al.	375/231
5,479,447	12/1995	Chow et al.	375/260
5,510,799	4/1996	Wishart	342/373
5,515,378	5/1996	Roy, III et al.	370/95.1
5,537,435	7/1996	Carney et al.	375/219
5,548,819	8/1996	Robb	455/59
5,566,209	10/1996	Forssen et al.	375/262
5,592,490	1/1997	Barratt et al.	370/310
5,634,199	5/1997	Gerlach et al.	455/63
5,642,353	6/1997	Roy, III et al.	370/329
5,649,287	7/1997	Forssen et al.	370/312

5,691,727	11/1997	Cyzs	342/361
5,752,173	5/1998	Tsujimoto	455/137
5,809,019	9/1998	Ichihara et al.	370/334
5,886,988	3/1999	Yun et al.	370/329
5,905,721	5/1999	Liu et al.	370/342
5,966,094	10/1999	Ward et al.	342/373

**FOREIGN PATENT DOCUMENTS**

0 253 465 B1	3/1987	European Pat. Off.	.
0253465 A1	3/1987	European Pat. Off.	.
WO 95/22873	8/1995	WIPO	.
WO 96/30964	10/1996	WIPO	.
WO 98/09381	3/1998	WIPO	.
WO 98/09395	3/1998	WIPO	.

**OTHER PUBLICATIONS**

J. Hirono, M. Saito and C. Kamise, Digital Terrestrial Television Broadcasting with OFDM—A Study on the Performance of Single Frequency Networks—International Broadcasting Convention, p. 178–183 (Sep., 1996).

P.A. Voois, “Two-dimensional Signal Processing for Magnetic Storage Systems,” *Ph.D. Thesis*, Stanford University, Stanford, CA, pp. 1–136 (Dec. 1993).

(List continued on next page.)

*Primary Examiner*—Stephen Chin

*Assistant Examiner*—Chieh M. Fan

*Attorney, Agent, or Firm*—Ritter, Van Pelt & Yi LLP

[57] **ABSTRACT**

A space-time signal processing system with advantageously reduced complexity. The system may take advantage of multiple transmitter antenna elements and/or multiple receiver antenna elements, or multiple polarizations of a single transmitter antenna element and/or single receiver antenna element. The system is not restricted to wireless contexts and may exploit any channel having multiple inputs or multiple outputs and certain other characteristics. Multipath effects in a transmission medium cause a multiplicative increase in capacity.

**32 Claims, 26 Drawing Sheets**

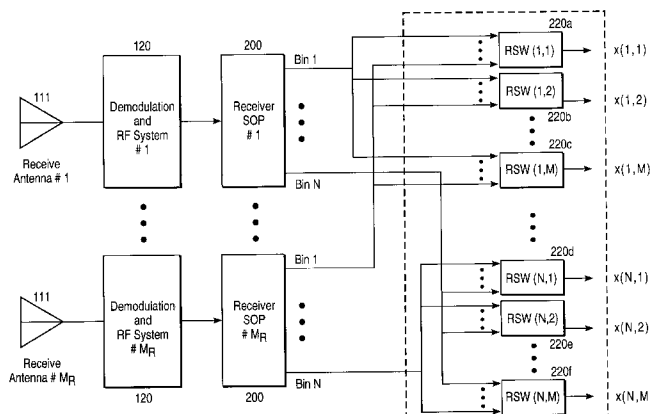

## OTHER PUBLICATIONS

- Ohkawa, Kouichi, "Performance of Multicarrier Trellis-Coded 8PSK Using Frequency Hopping in Rayleigh Fading Channels," National Conference Publication—Institution of Engineers, Australia, National Conference, vol. 1, p. 145–149, Nov. 20–24, 1994.
- Sourour, Essam A., "Performance of Orthogonal Multicarrier CDMA in a Multipath Fading Channel," IEEE Transactions on Communications, vol. 44, No. 3, p. 356–367, Mar. 1996.
- Ichikawa, Hirofumi, "Frequency Diversity Effects in Multicarrier Digital Radio Systems," Electronics and Communications in Japan, Part 1, vol. 74, No. 8, p. 70–77, Aug. 1991.
- Gudmundson, Mikael, "Spectral Efficiency of a Multitone Frequency Hopping System for Personal Communication Systems," IEEE Vehicular Technology Conference, Part 3 (of 3) Stockholm, vol. 3, p. 1650–1654, Jun. 8–10, 1994.
- Gulliver, T. Aaron, "Order Statistics Diversity combining in Worst Case Noise and Multitone Jamming," IEEE Vehicular Technology Conference, vol. 2, p. 804–809, Jul. 25–28, 1995.
- Monnier, R., "Digital Television Broadcasting with High Spectral Efficiency," IEEE Conference Publication No. 358, p. 380–384, Jul. 1992.
- Del Re, Enrico, "Digital Multicarrier Demodulator for Regenerative Communication Satellites," Alta Frequenza, vol. 57, No. 10, p. 545–559, Dec. 1988.
- Omori, Youko, "Multicarrier 16QAM System in Land Mobile Communications," IEICE Transactions on Communications, vol. E77–B, No. 5, p. 634–640, May 1994.
- Ananasso, Fulvio, "Clock Synchronous Multicarrier Demodulator for Multi-Frequency TDMA Communications Satellites," IEEE International Conference on Communications, vol. 3, p. 1059–1063, 1990.
- Friese, M., "Multicarrier Modulation with Low Peak-to-Average Power Ratio," Electronics Letters, vol. 32, No. 8, p. 713–714, Apr. 11, 1996.
- Benyassine, Adil, "Optimal Subchannel Structuring and Basis Selection for Discrete Multicarrier Modulation," IEEE Communication Theory Mini-Conference, Proceedings, CTMC, p. 97–101, 1995.
- Sawahashi, M., "Multicarrier 16QAM Transmission with Diversity Reception," Electronics Letters, vol. 32, No. 6, p. 522–523, Mar. 14, 1996.
- Daffara, Flavio, "A New Frequency Detector for Orthogonal Multicarrier Transmission Techniques," IEEE 45th Vehicular Technology Conference, p. 804–809, Jul. 25–28, 1995.
- C.E. Shannon, "Mathematical Theory of Communications: Part I and Part II," The Bell System Technical Journal, pp. 379–423, 623–656, 1948.
- S. A. Fectel and H. Meyr, "Optional Feedforward Estimation of Frequency-Selective Fading Radio Channels using Statistical Channel Information," in Proc. SUPERCOMM/ICC '92, vol. 2, (Chicago, IL), pp. 677–681, 1992.
- L.H. Brandenburg and A.D. Wyner, "Capacity of the Gaussian channel with Memory: The Multivariate Case," Bell Syst. Tech. Journ., vol. 53(5), pp. 745–778, May–Jun. 1974.
- R.S. Cheng and S. Verdú, "Gaussian Multiaccess Channels with ISI: Capacity Region and Multiuser Water-Filling," IEEE Trans. Inform. Theory, vol. 39(3), pp. 773–785, May 1993.
- J. Salz, Digital Transmission Over Cross-Coupled Linear
- A. Duel-Hallen, "Equalizers for Multiple Input Multiple Output Channels and PAM Systems with Cyclostationary Input Sequences," IEEE Journ. On Sel. Areas in Comm., vol. 10(3), pp. 630–639, Apr. 1992.
- J. Yang and S. Roy, "On Joint Transmitter and Receiver Optimization for Multiple-input Multiple-output (MIMO)-Transmission Systems," IEEE Trans. Commun, vol. 42–(12), pp. 3221–3231, Dec. 1994.
- J. Yang and S. Roy, "Joint Transmitter-Receiver Optimization for Multi-Input Multi-Output Systems with Decision Feedback," IEEE Trans. Information Theory, vol. 40(5), pp. 1334–1347, Sep. 1994.
- D.C. Cox and R.P. Leck, "Distributions of Multipath Delay Spread and Average Excess Delay for 910 Mhz Urban Mobile Radio Paths," IEEE Trans. Antennas and Prop., vol. AP–23, pp. 206–213, Mar. 1975.
- S.B. Weinstein and P.M. Ebert, "Data Transmission by Frequency-Division Multiplexing Using the Discrete Fourier Transform," IEEE Transactions on Communications, vol. 19(5), pp. 628–634, Oct. 1971.
- A. Ruiz, J.M. Cioffi, and S. Kasturia, "Discrete Multiple Tone Modulation with Coset Coding for the Spectrally Shaped Channel," IEEE Trans. Commun, vol. 40(6), pp. 1012–1029, Jun. 1992.
- R.M. Gray, "On the Asymptotic Eigenvalue Distribution of Toeplitz Matrices," IEEE Trans. Information Theory, vol. 18, pp. 725–730, Jun. 1972.
- G. Forney, "Maximum-Likelihood Sequence Estimation of Digital Sequences in the Presence of Intersymbol Interference," IEEE Trans. Inform. Theory, vol. IT–18(3), pp. 363–378, May 1972.
- J.L. Holsinger, "Digital Communications Over Fixed Time-Continuous Channels With Memory, with Special Application to Telephone Channels," M.I.T. Research Laboratory Electronics Report, vol. 430, 1964.
- T.M. Cover and J.A. Thomas, Elements of Information Theory. New York: John Wiley, chapter 2, pp. 12–49, chapter 8, pp. 183–223, chapter 10, pp. 239–265 1991.
- R.J. Muirhead, Aspects of Multivariate Statistical Theory, New York: John Wiley, chapters 4 and 5, 1982.
- W.C. Jakes, Microwave Mobile Communications. New York: John Wiley, chapters 1, 5 and 6, 1974.
- W. R. Braun and U. Dersch, "A Physical Mobile Radio Channel Model," IEEE Trans. Vehicular Technology, vol. 40, pp. 472–482, May 1991.
- A.E. Bryson and T.C. Ho, Applied Optimal Control, Washington D.C. Hemisphere Publishing, pp. 24–29, 1968.
- S. Kasturia, J. Aslanis, and J.M. Cioffi, "Vector Coding for Partial-Response Channels," IEEE Transactions on Information Theory, vol. 36(4), pp. 741–762, Jul. 1990.
- E. Biglieri, D. Divsalar, P.J. McLane, and M.K. Simon, Introduction to Trellis Coded Modulation with Applications. New York: Macmillan Publishing, 1991.
- P. Lancaster, Theory of Matrices. New York: Academic Press, chapter 2, 1969.
- G.G. Raleigh and J.M. Cioffi, "Spatio-Temporal Coding for Wireless Communications." Submitted to IEEE Transactions on Communications, Jan. 1996.
- Justin C.-I. Chuang, "Burst Coherent Demodulation with Combined Symbol Timing, Frequency Offset Estimation, and Diversity Selection," IEEE Transactions on Communications, vol. 39, No. 7, pp. 1157–1164, Jul. 1991.
- Leonard J. Cimini, Jr., "Analysis and Simulation of a Digital Mobile Channel Using Orthogonal Frequency Division

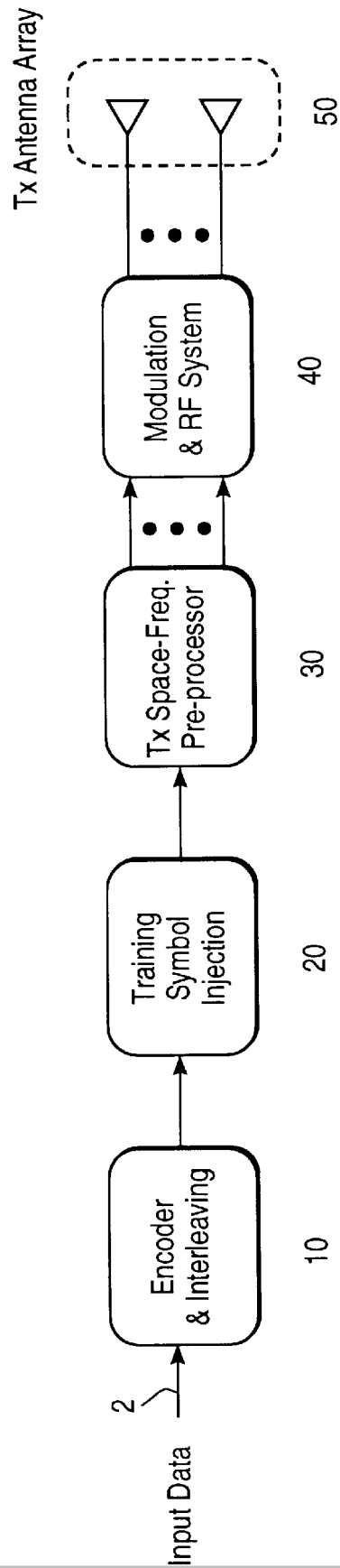

FIG. 1

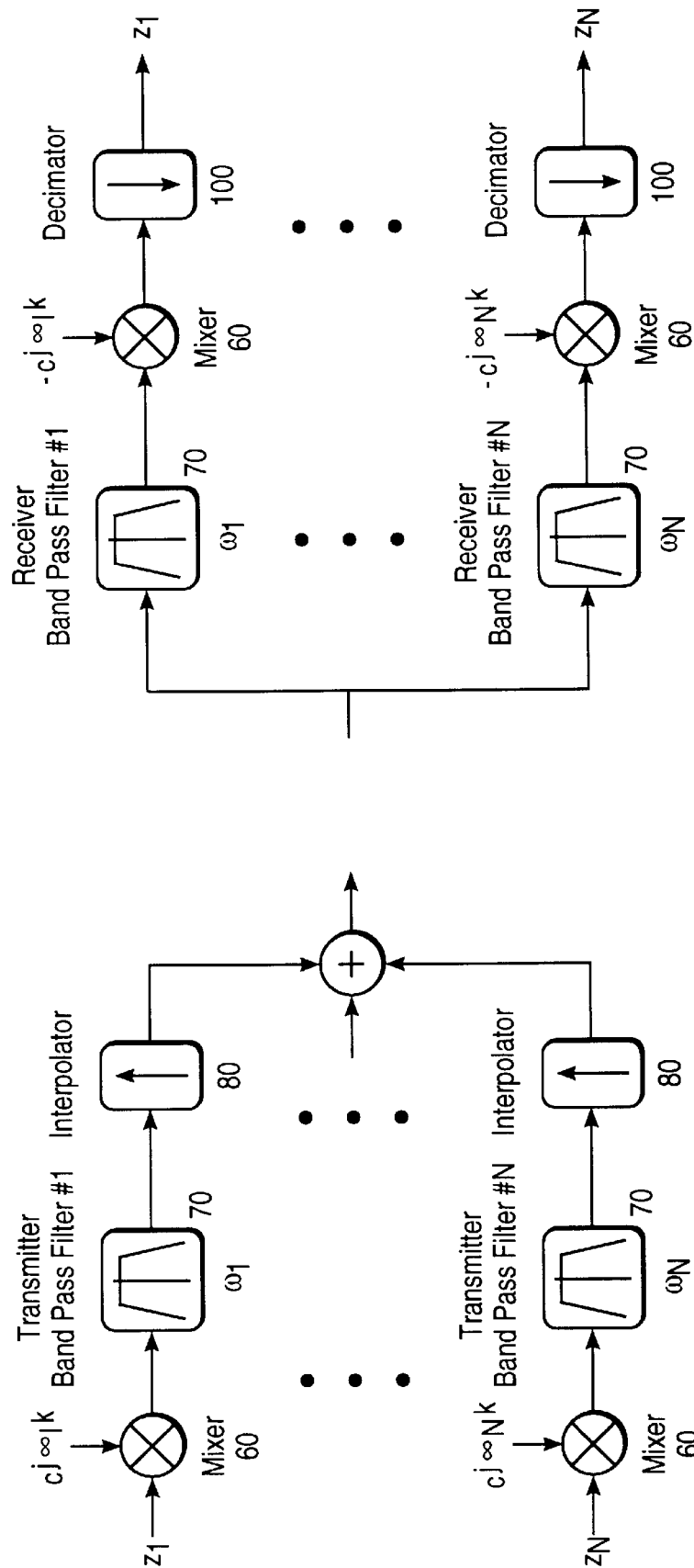

FIG. 2

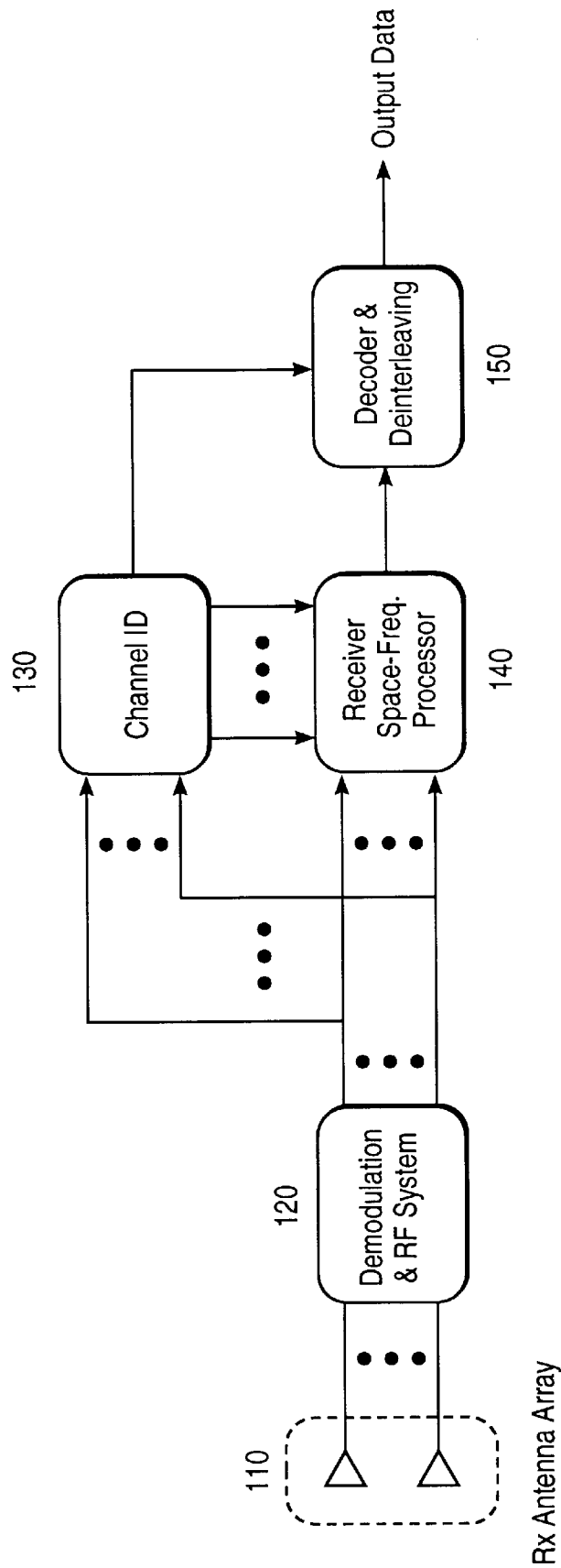

FIG. 3

# Explore Litigation Insights

Docket Alarm provides insights to develop a more informed litigation strategy and the peace of mind of knowing you're on top of things.

## Real-Time Litigation Alerts



Keep your litigation team up-to-date with **real-time alerts** and advanced team management tools built for the enterprise, all while greatly reducing PACER spend.

Our comprehensive service means we can handle Federal, State, and Administrative courts across the country.

## Advanced Docket Research



With over 230 million records, Docket Alarm's cloud-native docket research platform finds what other services can't. Coverage includes Federal, State, plus PTAB, TTAB, ITC and NLRB decisions, all in one place.

Identify arguments that have been successful in the past with full text, pinpoint searching. Link to case law cited within any court document via Fastcase.

## Analytics At Your Fingertips



Learn what happened the last time a particular judge, opposing counsel or company faced cases similar to yours.

Advanced out-of-the-box PTAB and TTAB analytics are always at your fingertips.

## API

Docket Alarm offers a powerful API (application programming interface) to developers that want to integrate case filings into their apps.

## LAW FIRMS

Build custom dashboards for your attorneys and clients with live data direct from the court.

Automate many repetitive legal tasks like conflict checks, document management, and marketing.

## FINANCIAL INSTITUTIONS

Litigation and bankruptcy checks for companies and debtors.

## E-DISCOVERY AND LEGAL VENDORS

Sync your system to PACER to automate legal marketing.