

(12) **UK Patent Application** (19) **GB** (11) **2 282 730** (13) **A**

(43) Date of A Publication **12.04.1995**

(21) Application No **9320814.8**

(22) Date of Filing **08.10.1993**

(71) Applicant(s)

Nokia Telecommunications OY

(Incorporated in Finland)

Mäkkylän Puistotie 1, SF-02600 Espoo, Finland

Nokia Mobile Phones Limited

(Incorporated in Finland)

P.O. Box 86, SF-24101 Salo, Finland

(72) Inventor(s)

John Byrne

Teuvo Järvelä

Sanna Mäenpää

(51) INT CL⁶

H04Q 7/38

(52) UK CL (Edition N)

H4L LDSC L1H10 L1H3

(56) Documents Cited

GB 2225512 A WO 93/16560 A

(58) Field of Search

UK CL (Edition L.) H4K KYX KY4 KY4D KY4D14 KY4D8

KY4P, H4L LDSD

INT CL⁵ H04Q 7/04

ONLINE : WPI

(74) Agent and/or Address for Service

Frank B Dehn & Co

Imperial House, 15-19 Kingsway, LONDON,

WC2B 6UZ, United Kingdom

(54) **Handover procedure in a dual-mode telecommunication network**

(57) A dual mode terminal 20 comprises a combined mobile station 21 and a cordless telephone 22 and may communicate with both a base station of a mobile radio system and a base station of the cordless telephone system. In a terminal initiated handover of a call from the cordless telephone system to a base station of the mobile radio system, the cordless telephone part obtains from the mobile station measurements of received signal strengths of the mobile system base stations in the neighborhood. These are forwarded via a base station of the cordless telephone system to the mobile exchange of the mobile system in a handover request message. The mobile exchange selects a suitable base station for handover based on the measurements and informs the mobile station part of the terminal about the identity of the selected base station via the cordless telephone part.

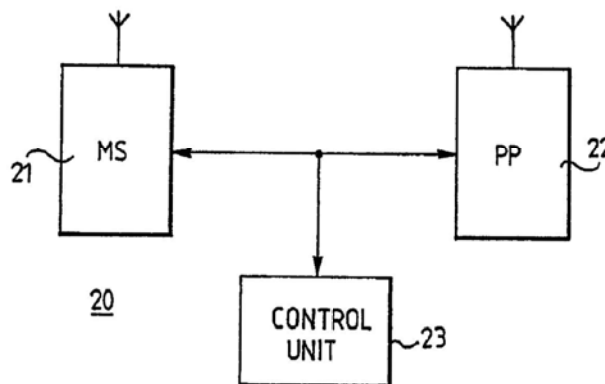

FIG. 2

GB 2 282 730 A

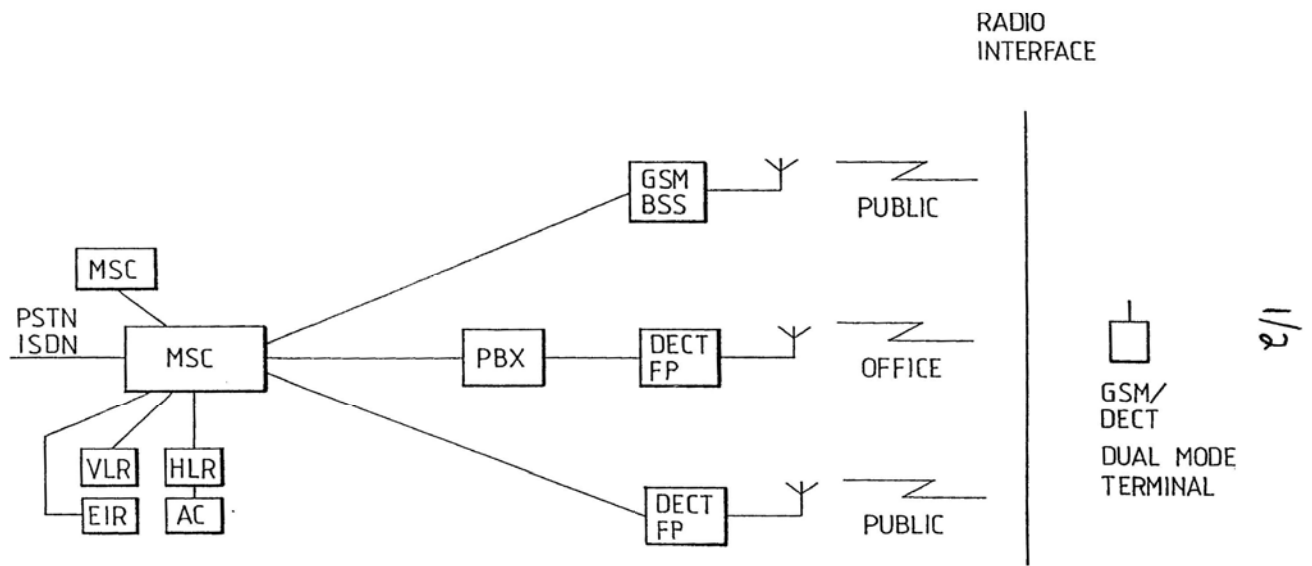

FIG. 1

2/2

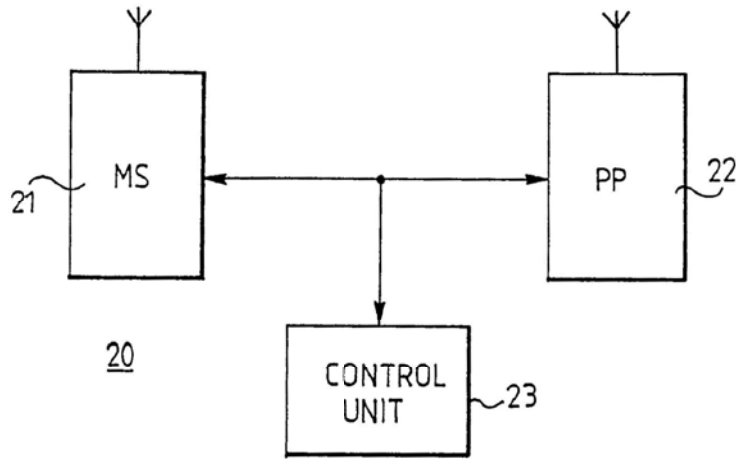

FIG. 2

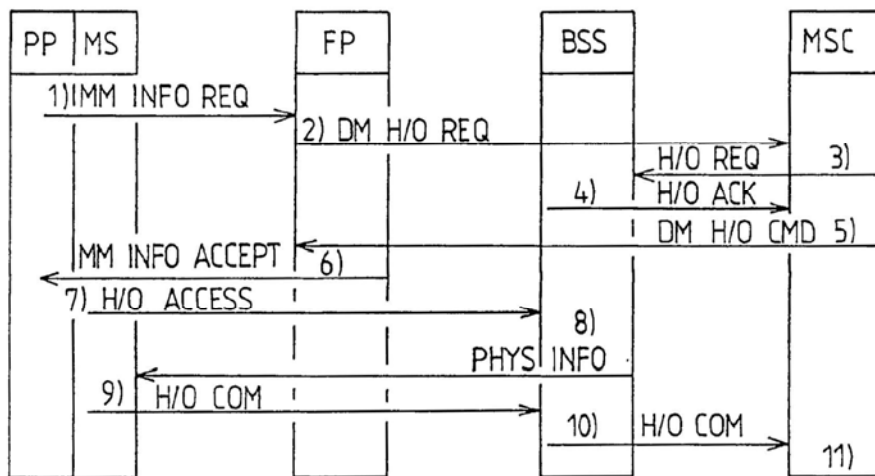

FIG. 3

Dual mode subscriber terminal and a handover procedure of the dual mode subscriber terminal in a mobile telecommunication network

5 The invention relates to a mobile telecommunications system including a fixed network comprising mobile exchanges, base stations for mobile stations, and cordless telephone base stations connected to and under control of said mobile exchanges. In particular, the present
10 invention relates to a method for performing handover from the cordless telephone base stations to base stations for mobile stations.

 Conventional cordless telephones operate as an extension to the Public Switched Telephone Network (PSTN). A
15 cordless telephone system consists of a portable handset and a base station (a fixed part) connected to PSTN. The first cordless telephone systems were analog systems, such as CT1. Recently digital cordless telephone systems, such as CT2 and DECT (Digital European Cordless Telephone) have
20 been introduced. When a cordless telephone is a subscriber of PSTN, a cordless telephone is accessed by dialing the telephone number associated with the fixed subscriber connection to which the base station is connected. Also the subscriber has access to the PSTN only via the home
25 base station. In CT2 and DECT, also a telepoint service is introduced, whereby subscriber to the service can make calls away from home via a public base station. Also a common air interface for cordless telephones was introduced to facilitate roaming between systems and so to improve
30 service coverage for the use.

 There has also been a proposal to combine a cordless telephone system with a cellular mobile telecommunications system to further improve the roaming capabilities by means of utilization of the mobility
35 control of the cellular network. When combined with the

mobile telecommunications systems, the roaming of the cordless telephone handsets within the cordless telephone systems is fully supported. However, the cordless telephone handset is not able to utilize the more extensive radio coverage of the supporting cellular network or to perform handover to or from the cellular network. This disadvantage is due to several reasons.

5
10 Firstly, the radio interfaces of cordless telephone systems and the mobile radio systems are usually incompatible.

15 Secondly, the handover procedures are different. In cordless telephone systems, the handover procedure is usually initiated by the portable terminal. More particularly, when a cordless telephone terminal considers it necessary to change from one base station to another, the terminal scans the frequency band and selects the appropriate base station for the handover. In most of the mobile telephone systems the handover is controlled by the network. The mobile station only measures the quality of the radio connection and forwards the measuring results to the fixed network. One of the network elements, for example a mobile exchange, makes a decision for handover on the basis of the obtained information.

20
25 It is an object of the invention to provide a subscriber terminal capable of communicating with both a fixed part of a cordless telephone system and a base station of the mobile radio system.

30 It is a further object of the invention to provide a method for performing handover from a fixed part of a cordless telephone system to a base station of a mobile telecommunications system.

35 One aspect of the invention is, in a mobile telecommunications system including a fixed network comprising mobile exchanges, first base stations connected to said mobile exchanges, and second base stations of a cordless

Explore Litigation Insights

Docket Alarm provides insights to develop a more informed litigation strategy and the peace of mind of knowing you're on top of things.

Real-Time Litigation Alerts



Keep your litigation team up-to-date with **real-time alerts** and advanced team management tools built for the enterprise, all while greatly reducing PACER spend.

Our comprehensive service means we can handle Federal, State, and Administrative courts across the country.

Advanced Docket Research



With over 230 million records, Docket Alarm's cloud-native docket research platform finds what other services can't. Coverage includes Federal, State, plus PTAB, TTAB, ITC and NLRB decisions, all in one place.

Identify arguments that have been successful in the past with full text, pinpoint searching. Link to case law cited within any court document via Fastcase.

Analytics At Your Fingertips



Learn what happened the last time a particular judge, opposing counsel or company faced cases similar to yours.

Advanced out-of-the-box PTAB and TTAB analytics are always at your fingertips.

API

Docket Alarm offers a powerful API (application programming interface) to developers that want to integrate case filings into their apps.

LAW FIRMS

Build custom dashboards for your attorneys and clients with live data direct from the court.

Automate many repetitive legal tasks like conflict checks, document management, and marketing.

FINANCIAL INSTITUTIONS

Litigation and bankruptcy checks for companies and debtors.

E-DISCOVERY AND LEGAL VENDORS

Sync your system to PACER to automate legal marketing.