

Othello™: A New Direct-Conversion Radio Chip Set Eliminates IF Stages

by Dan Fague

INTRODUCTION

Analog Devices recently announced the revolutionary Othello direct-conversion radio for mobile applications. By eliminating intermediate-frequency (IF) stages, this chip set will permit the mobile electronics industry to reduce the size and cost of radio sections and enable flexible, multistandard, multimode operation. The radio consists of two integrated circuits, the AD6523 Zero-IF Transceiver and the AD6524 Multiband Synthesizer. The AD6523 contains the main functions necessary for both a direct-conversion receiver and a direct VCO transmitter, known as the Virtual-IF™ transmitter. It also includes the local-oscillator generation block and a complete on-chip regulator that supplies power to all active circuitry for the radio. The AD6524 is a fractional-N synthesizer that features extremely fast lock times to enable advanced data services over cellular telephones—such as high-speed circuit-switched data (HSCSD) and general packet radio services (GPRS).

Together, the two ICs supply the main functions necessary for implementing dual- or triple-band radios for GSM cellular phones. The direct conversion technology, combined with a new twist on the translation loop (or direct VCO) modulator, reduces the amount of external filtering needed in the radio to an absolute minimum.

THE GSM STANDARD

The Global system for mobiles (GSM) was officially launched in 1992, after over five years of standards writing by the European Telecommunications Standards Institute (ETSI). The goal of GSM was to unite a Babel of European communications under one digital cellular standard. Before GSM, Europe maintained in effect one separate cellular network for each country, making international roaming on the continent virtually impossible. With GSM, a citizen of any of the original seventeen countries could roam to any other country using a single cellular handset. The standard, which was written with future expansion to data services and other applications in mind, soon became popular around the world. It is now accepted in more than 140 countries, with over 200 networks running.

The frequency bands originally allocated to GSM were 890 to 915 MHz for mobile transmitting and 935 to 960 MHz for mobile receiving. That band was expanded to the so-called E-GSM bands of 880 to 915 MHz and 925 to 960 MHz. Another frequency allocation was made to further expand GSM capacity. This band, allocated to digital communications services (DCS), was 1710 to 1785 MHz and 1805 to 1880 MHz. All countries adopting GSM use one of these two pairs of frequency bands, except the United States, where both bands were already allocated by the FCC. The Personal Communications Services (PCS) frequency auctions in the mid-1990s made available a set of bands for GSM in the U.S.—1850 to 1910 MHz and 1930 to 1990 MHz.

Othello, Superhodyne and Virtual-IF are trademarks of Analog Devices, Inc.

Today's typical GSM handset (or handy) will have 2-W output power and is required to receive signals as low as -102 dBm (less than 1/10 of a picowatt). The handy includes a powerful digital signal processor (DSP) core (equivalent to an ADSP-218x) to encode, encrypt, interleave, packetize, transmit, receive, de-packetize, de-interleave, de-encrypt, and de-encode the data going to and coming from the voiceband A/D and D/A converters. An equally powerful microcontroller (ARM or Hitachi H8), combined with a hardware burst processor, controls the timing necessary to implement the time-division multiple-access (TDMA) and frequency hopping functions to keep the phone call on a specific time and frequency channel. The microcontroller also implements the man-machine interface, and operates all the necessary protocols for communication to the base stations.

RADIO ARCHITECTURE DESIGN

Most digital cellular phones today include at least one "downconversion" in their signal chain. This frequency conversion shifts the desired signal from the allocated RF band for the standard (say, at 900 MHz) to some lower intermediate frequency (IF), where channel selection is performed with a narrow channel-select filter (usually a surface acoustic-wave (SAW) or a ceramic type). The now-filtered signal is then further down-converted to either a second IF or directly to baseband, where it is digitized and demodulated in a digital signal processor (DSP).

The idea of using direct-conversion for receivers has long been of interest in RF design. The reason is obvious: in consumer equipment conversion stages add cost, bulk, and weight. Each conversion stage requires a local oscillator, (often including a frequency synthesizer to lock the LO onto a given frequency), a mixer, a filter, and (possibly) an amplifier. No wonder, then, that direct conversion receivers would be attractive. All intermediate stages are eliminated, reducing the cost, volume, and weight of the receiver.

The first Othello radio reduces the component count even more by integrating the front-end GSM low-noise amplifier (LNA). This eliminates an RF filter (the "image" filter) that is necessary to eliminate the image, or unwanted mixing product of a mixer and the off chip LNA. This stage, normally implemented with a discrete transistor, plus biasing and matching networks, accounts for a total of about 12 components. Integrating the LNA saves a total of about 15 to 17 components, depending on the amount of matching called for by the (now-eliminated) filter.

SUPERHODYNE™ DIRECT-CONVERSION RECEIVER

A functional block diagram of the Othello dual band GSM radio's architecture is shown in Figure 1. The receive section is at the top of the figure. From the antenna connector, the desired signal enters the transmit/receive switch and exits on the appropriate path, either 925-960 MHz for the GSM band or 1805-1880 MHz for DCS. The signal then passes through an RF band filter (a so-called "roofing filter") that serves to pass the entire desired frequency band while attenuating all other out-of-band frequencies (blockers—including frequencies in the transmission band) to prevent them from saturating the active components in the radio front end. The roofing filter is followed by the low-noise amplifier (LNA). This is the first gain element in the system, effectively reducing the contribution of all following stages to system noise. After the LNA, the direct-conversion mixer translates the desired signal from radio frequency (RF) all the way to baseband by

multiplying the desired signal with a local oscillator (LO) output at the same frequency.

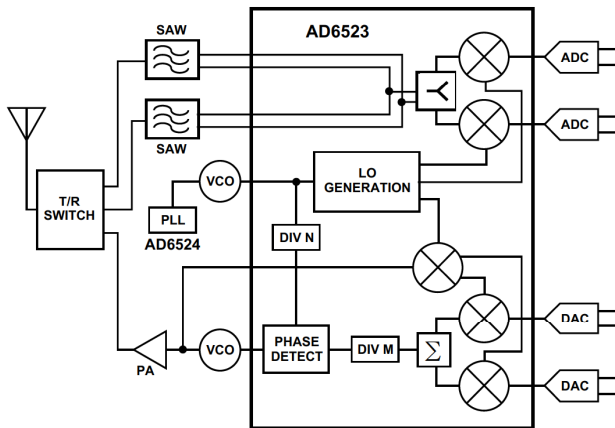

Figure 1. Block diagram of the Othello dual-band radio.

The output of the mixer stage is then sent in quadrature (I and Q channels) to the variable-gain baseband amplifier stage. The VGA also provides some filtering of adjacent channels, and attenuation of in-band blockers. These blocking signals are other GSM channels that are some distance from the desired channel, say 3 MHz and beyond. The baseband amplifiers filter these signals so that they will not saturate the Receive ADCs. After the amplifier stage, the desired signal is digitized by the Receive ADCs.

VIRTUAL-IF™ TRANSMITTER

The Transmit section begins on the right, at the multiplexed I and Q inputs/outputs. Because the GSM system is a time division duplex (TDD) system, the transmitter and receiver are never on at the same time. The Othello radio architecture takes advantage of this fact to save four pins on the transceiver IC's package. The quadrature transmit signals enter the transmitter through the multiplexed I/Os. These I and Q signals are then modulated onto a carrier at an intermediate frequency greater than 100 MHz.

The output of the modulator goes to a phase-frequency detector (PFD), where it is compared to a reference frequency that is generated from the external channel selecting LO. The output of the PFD is a charge pump, operating at above 100 MHz, whose output is filtered by a fairly wide (1 MHz) loop filter. The output of the loop filter drives the tuning port of a voltage-controlled oscillator (VCO), with frequency ranges that cover the GSM and DCS transmit bands.

The output of the transmit VCO is sent to two places. The main path is to the transmit power amplifier (PA), which amplifies the transmit signal from about +3 dBm to +35 dBm, sending it to the transmit/receive switch and low-pass filter (which attenuates power-amplifier harmonics). The power amplifiers are dual band, with a simple CMOS control voltage for the band switch. The VCO output also goes to the transmit feedback mixer by means of a coupler, which is either a printed circuit, built with discrete inductors and capacitors, or a monolithic (normally ceramic) coupling device. The feedback mixer downconverts the transmit signal to the transmit IF, and uses it as the local oscillator signal for the transmit modulator.

This type of modulator has several names, but the most descriptive is probably "translation loop." The translation loop modulator takes advantage of one key aspect of the GSM standard: the modulation

scheme is Gaussian-filtered minimum-shift keying (GMSK). This type of modulation does not affect the envelope amplitude, which means that a power amplifier can be saturated and still not distort the GMSK signal sent through it.

GMSK can be generated in several different ways. In another European standard (for cordless telephones), GMSK is created by directly modulating a free running-VCO with the Gaussian filtered data stream. In GSM, the method of choice has been quadrature modulation. Quadrature modulation creates accurate phase GMSK, but imperfections in the modulator circuit (or up-conversion stages) can produce envelope fluctuations, which can in turn degrade the phase trajectory when amplified by a saturated power amplifier. To avoid such degradations, GSM phone makers have been forced to use amplifiers with somewhat higher linearity, at the cost of reduced efficiency and talk time per battery charge cycle.

The translation loop modulator combines the advantages of directly modulating the VCO and the inherently more accurate quadrature modulation. In effect, the scheme creates a phase locked loop (PLL), comprising the modulator, the LO signal, and the VCO output and feedback mixer. The result is a directly modulated VCO output with a perfectly constant envelope and almost perfect phase trajectory. Phase trajectory errors as low as 1.5 degrees have been measured in the AD6523 transceiver IC, using a signal generator as the LO signal to provide a reference for the loop.

FREQUENCY PLANNING

An important aspect of the Othello radio design is the frequency plan. The GSM standard has strict requirements with regard to in- and out-of-band spurious emissions. A GSM cellular phone must be able to withstand blockers at extremely high levels (0 dBm) while continuing to receive normally. The phone must also not emit spurious signals into other bands above a certain level (in the GSM receive band, -112 dB relative to the transmitted signal!).

The Othello radio architecture was designed with the entire system in mind. The frequency plan was carefully crafted to satisfy three equally important criteria:

- 1) Reduce spurious emissions from the radio.
- 2) Minimize bandwidth of the dual band local oscillator (LO) VCO.
- 3) Eliminate as many potential blockers as possible.

By satisfying all of these criteria, major radio problems have been solved, always keeping the end-user and the application in mind. The final solution turned out to be both elegant and practical.

Reducing Spurious Emissions from the Radio

Spurious emissions from the radio can cause problems in both Transmit and Receive modes. A wayward LO signal can find its way to the antenna and "self block" a direct-conversion receiver, reducing sensitivity. The LO signal can also radiate from the antenna and degrade the performance of other receivers.

In the Othello frequency plan, the local oscillator's center frequency was chosen to be about 1350 MHz. This placed the LO strategically between the GSM and DCS frequency bands, enabling a single LO to be used for both GSM and DCS, saving components. Since that frequency is distant from either of the bands, the radio's front end filters will attenuate any radiated LO signal, and so it doesn't pose a problem as a radiated spurious emission. Even if the signal is coupled directly from pin to pin on the IC, its power level would

be lower than the GSM requirements for in- or out-of-band blockers received at the antenna.

In the Transmit section, spurious signals can also pose a problem. Though the transmitter is a direct VCO modulator, the feedback mixer will introduce spurious signals at its output that must be filtered before entering the phase detector. Otherwise, they could appear at the output themselves or cause still other spurious signals to appear by mixing with the desired modulation signal due to the non-linear operation of the phase detector input stage. This is a problem inherent in any translation-loop modulator. By using a widely separated LO frequency, the Othello architecture simplifies filtering of these products.

Minimize bandwidth of the dual band local-oscillator VCO

The Othello architecture was designed to minimize the number of external components needed to build a complete dual-band radio. The frequency plan was specifically chosen to make it possible for a single LO VCO to cover both GSM and DCS frequency bands while still meeting the necessarily stringent phase-noise specifications at the 3-MHz offset demanded of all GSM LO VCOs. By keeping the bandwidth requirements of the VCO to a minimum, the VCO can be designed with a maximum supply voltage of 2.7 V. This allows the entire dual-band radio to run at 2.7 V, reducing power consumption and enabling the use of nickel-cadmium (NiCd), nickel metal-hydride (NiMH), or lithium-ion (Li-ion) battery types.

Eliminate as Many Potential Blockers as Possible

As a result of the direct-conversion receiver architecture, the Othello radio has fewer “trouble” channels for the blocking tests required by GSM. Superheterodyne receivers must always contend with half-IF responses that are difficult to filter with RF filters due to the shape factors required. By going to direct conversion Othello eliminates the half-IF response.

PERFORMANCE

One of the key advantages of the Othello radio is that the reduction in the number of components needed to implement it does not engender performance sacrifices. In both the GSM and DCS bands, the Othello system noise figure allows for a production margin of about 6 dB from the required receiver sensitivity of -102 dBm. The transmitter provides a similar production margin, with phase trajectory errors of 2.5° rms, compared with the requirement of 5° rms.

FUTURE BENEFITS

Another important feature of the Othello radio is that the AD6524's fractional-N synthesizer has a lock time short enough to enable GPRS operation. [GPRS, an extension to the GSM network coming in year 2000, will allow very high data rates to be used by a compliant GSM handset.] A requirement of GPRS operation is that the LO synthesizer must lock in less than half a GSM time slot (lock times less than 250 μs). The AD6524, with its fractional-N synthesizer, is able to reach lock faster than conventional synthesizers, because fractional-N types operate at reference frequencies that are higher than the channel spacing, thus jumping more than one channel per reference cycle. In the case of the AD6524, the 26-MHz reference frequency, twice the system crystal frequency (compared to a channel spacing of 200 kHz), ensures that the Othello radio will meet the required lock time for GPRS. Fast lock time also helps to reduce power consumption by allowing the baseband section to keep the radio off for longer time intervals.

The Othello radio has opened new doors of opportunity for the future. Today, a complete dual-band Othello radio, including all power-management functions, can be implemented with only 90 components. With so few components, the radio can be implemented in less than 10 cm² of board space. Figure 2 is a photograph of a prototype radio design for Othello, implemented on a four layer PCB. Compare this to a superheterodyne receiver that today uses about 225 components crowded into somewhat less than 15 cm² of board space for the same functionality. (Even that is an improvement over radios of just two years ago, which used the same number of components to implement a single band GSM radio!) The advantages of direct conversion translate directly to lower costs in many ways: fewer components means that an original-equipment manufacturer (OEM) spends less on bill of materials (BOM) and less for inserting the components (about a penny per insertion). The time to assemble a phone is reduced, increasing factory throughput; and the improved manufacturability of the phone (less to go wrong with fewer solder joints, etc.) increases reliability.

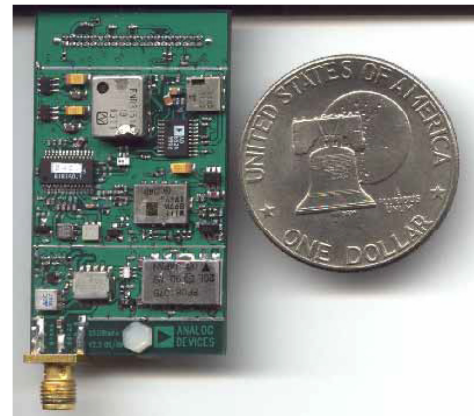

Figure 2. Photograph of a prototype Othello radio printed circuit board.

Because Othello radios can be so compact, they enable GSM radio technology to be incorporated in many products from which it has been excluded, such as very compact phones or PCMCIA cards. However, the real power of direct conversion will be seen when versatile third-generation phones are designed to handle multiple standards. With direct-conversion, hardware channel-selection filters will be unnecessary, because channel selection is performed in the digital signal-processing section, which can be programmed to handle multiple standards. Contrast this with the superheterodyne architecture; the multiple radio circuits required to handle the different standards (because each will require different channel-selection filters) will all have to be crowded into a small space. With direct conversion, the same radio chain could in concept be used for several different standards, bandwidths, and modulation types. Thus, Web-browsing and voice services could, in concept, occur over the GSM network using the same radio in the handset.

ANALOG DEVICES AND GSM

For the future, the Othello radio is only the first of a family of direct-conversion receiver solutions from Analog Devices. More are in the works. But this technology is well-grounded in nearly a decade of product designs for the GSM industry. ADI chips can be found in millions of GSM handsets in use worldwide.