



US005425050A

# United States Patent [19]

[11] Patent Number: **5,425,050**

Schreiber et al.

[45] Date of Patent: **Jun. 13, 1995**

[54] TELEVISION TRANSMISSION SYSTEM USING SPREAD SPECTRUM AND ORTHOGONAL FREQUENCY-DIVISION MULTIPLEX

[75] Inventors: William F. Schreiber, Cambridge; Michael O. Polley, Belmont, both of Mass.

[73] Assignee: Massachusetts Institute of Technology, Cambridge, Mass.

[21] Appl. No.: 149,264

[22] Filed: Nov. 9, 1993

### Related U.S. Application Data

[63] Continuation-in-part of Ser. No. 965,227, Oct. 23, 1992, Pat. No. 5,311,543.

[51] Int. Cl.<sup>6</sup> ..... H04N 7/167

[52] U.S. Cl. .... 375/200; 380/10; 380/13

[58] Field of Search ..... 375/1; 380/10, 20, 13, 380/19

### [56] References Cited

#### U.S. PATENT DOCUMENTS

3,488,445	1/1970	Chang .	
4,425,642	1/1984	Moses et al. ....	375/1
4,821,120	4/1989	Tomlinson .....	375/1
4,890,283	12/1989	Tsinberg et al. ....	375/1
4,907,087	3/1990	Schreiber .....	358/186
4,912,721	3/1990	Pidgeon et al. ....	375/1
5,073,899	12/1991	Collier et al. ....	375/1
5,127,021	6/1992	Schreiber .....	375/1
5,311,543	5/1994	Schreiber et al. ....	380/10

#### OTHER PUBLICATIONS

Weinstein, S. B. et al., "Data Transmission by Frequency-Division Multiplexing Using the Discrete Fourier Transform", IEEE Transactions on Communication Technology, vol. COM-19, No. 5, Oct. 1971, pp. 628-634.

Hirosaki, B., "An Orthogonally Multiplexed QAM System Using the Discrete Fourier Transform", IEEE

Transactions on Communications, vol. COM-29, No. 7, Jul. 1981, pp. 982-989.

Chang, R. W., "Synthesis of Band-Limited Orthogonal Signals for Multichannel Data Transmission", The Bell System Technical Journal, Dec. 1966, pp. 1775-1796.

Pommier, D. et al., "A Hybrid Satellite/Terrestrial Approach for Digital Audio Broadcasting With Mobile and Portable Receivers", NAB Engineering Conference Proceedings, 1990, pp. 304-311.

"Description of the COFDM System", Groupement D'Interet Economique Regipar L'Ordonnance Du, Sep. 23, 1967.

Alard, M. et al., "Principles of Modulation and Channel Coding for Digital Broadcasting for Mobile Receivers", EBU Review-Technical, No. 224, Aug. 1987, pp. 168-190.

Primary Examiner—David C. Cain

Attorney, Agent, or Firm—Fish & Richardson

### [57] ABSTRACT

An apparatus for encoding a television production signal for transmission, the television production signal including a first input signal carrying a first class of data and a second input signal carrying a second class of data, the second class data requiring a higher-quality transmission the first class data. For each word of the first input signal, the first stage generates N serial samples of the first output sample stream, each of the N serial samples being formed by a different combination of a set of more than one of the N samples of the each word. The second stage includes an input stage combining the second input signal stream with the first output sample stream to generate an intermediate input sample stream; a serial-to-parallel converter receiving the intermediate input sample stream and producing a second stream of words therefrom, each of the words of which being a parallel grouping of M successive samples of the intermediate input sample stream; a Discrete Fourier Transform (DFT) module producing a parallel output stream of words that is the discrete Fourier transform of the second word stream; and a parallel-to-series converter generating the FDM output signal from the parallel output stream of the DFT module.

53 Claims, 11 Drawing Sheets

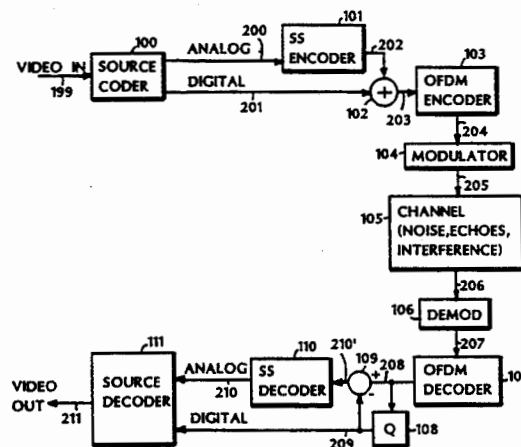

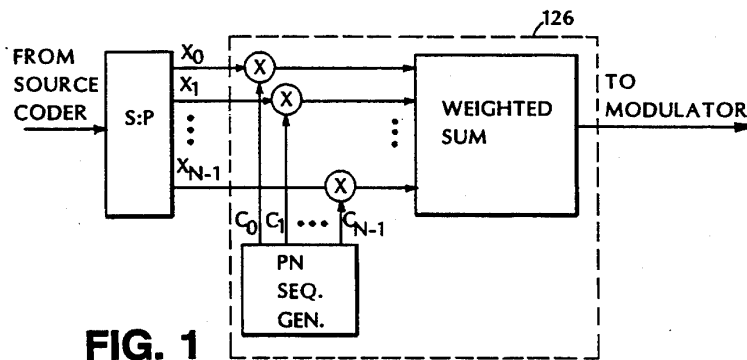

FIG. 1

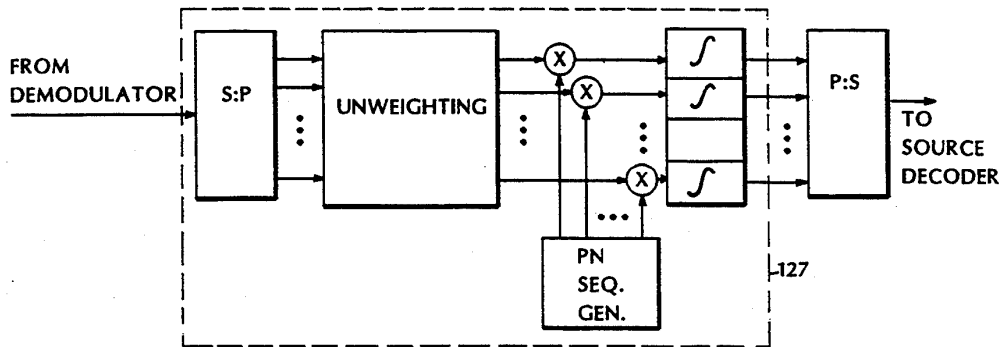

FIG. 2

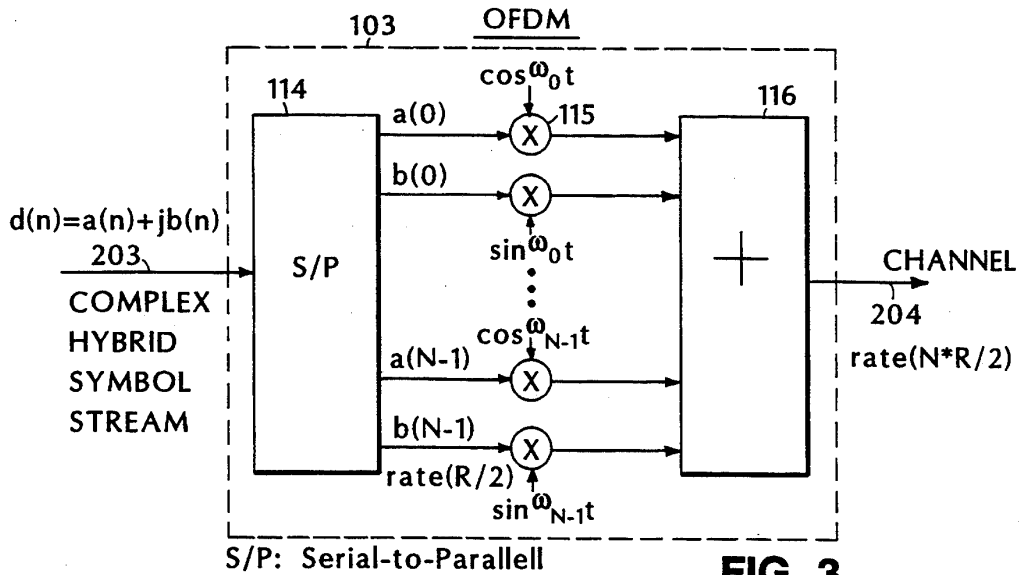

FIG. 3

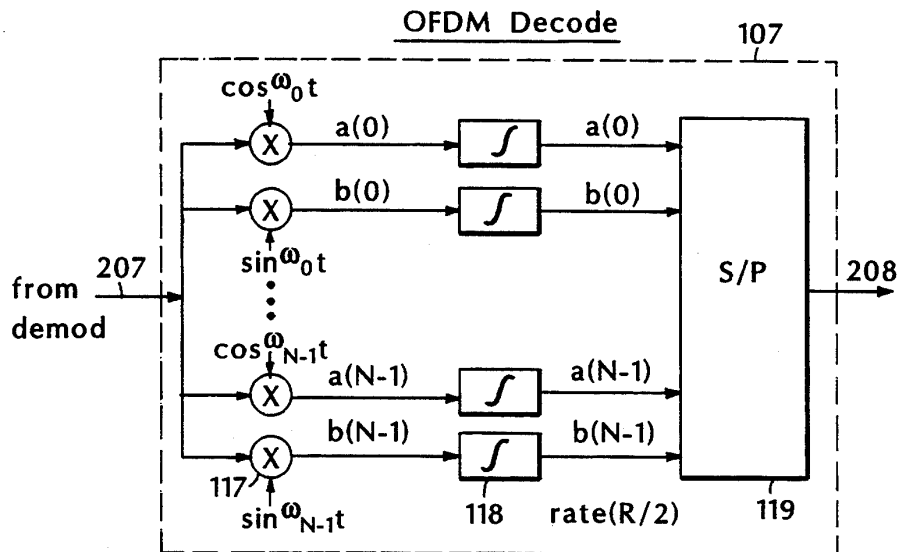

FIG. 4

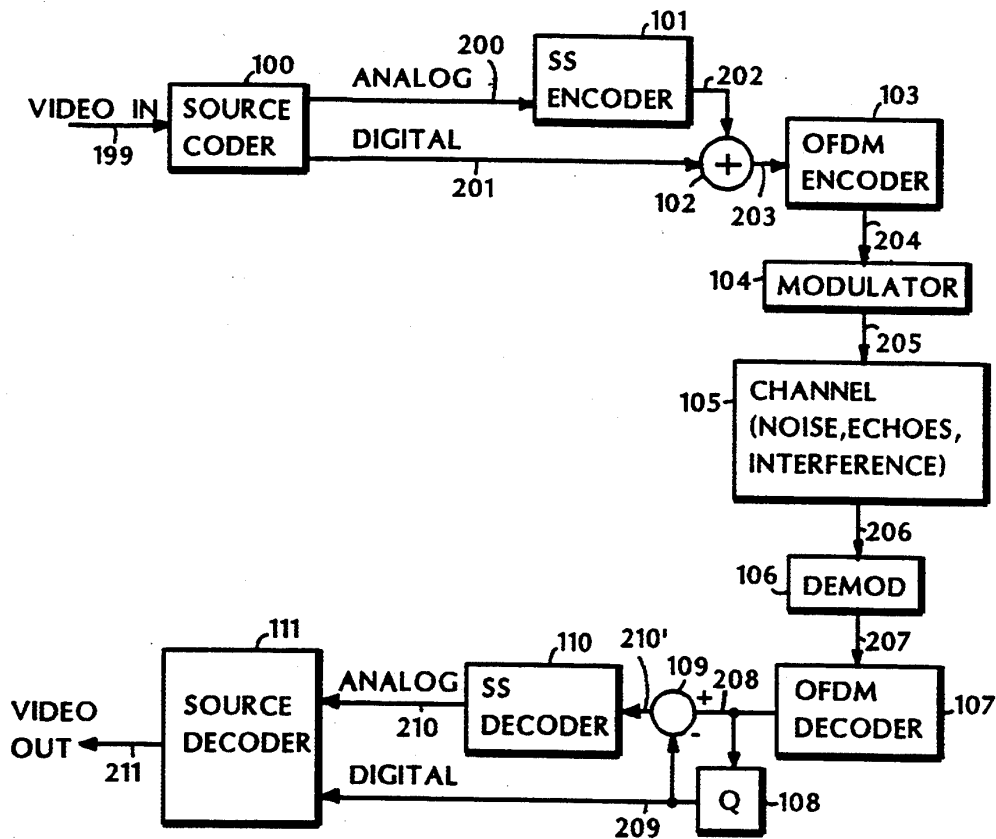

FIG. 5

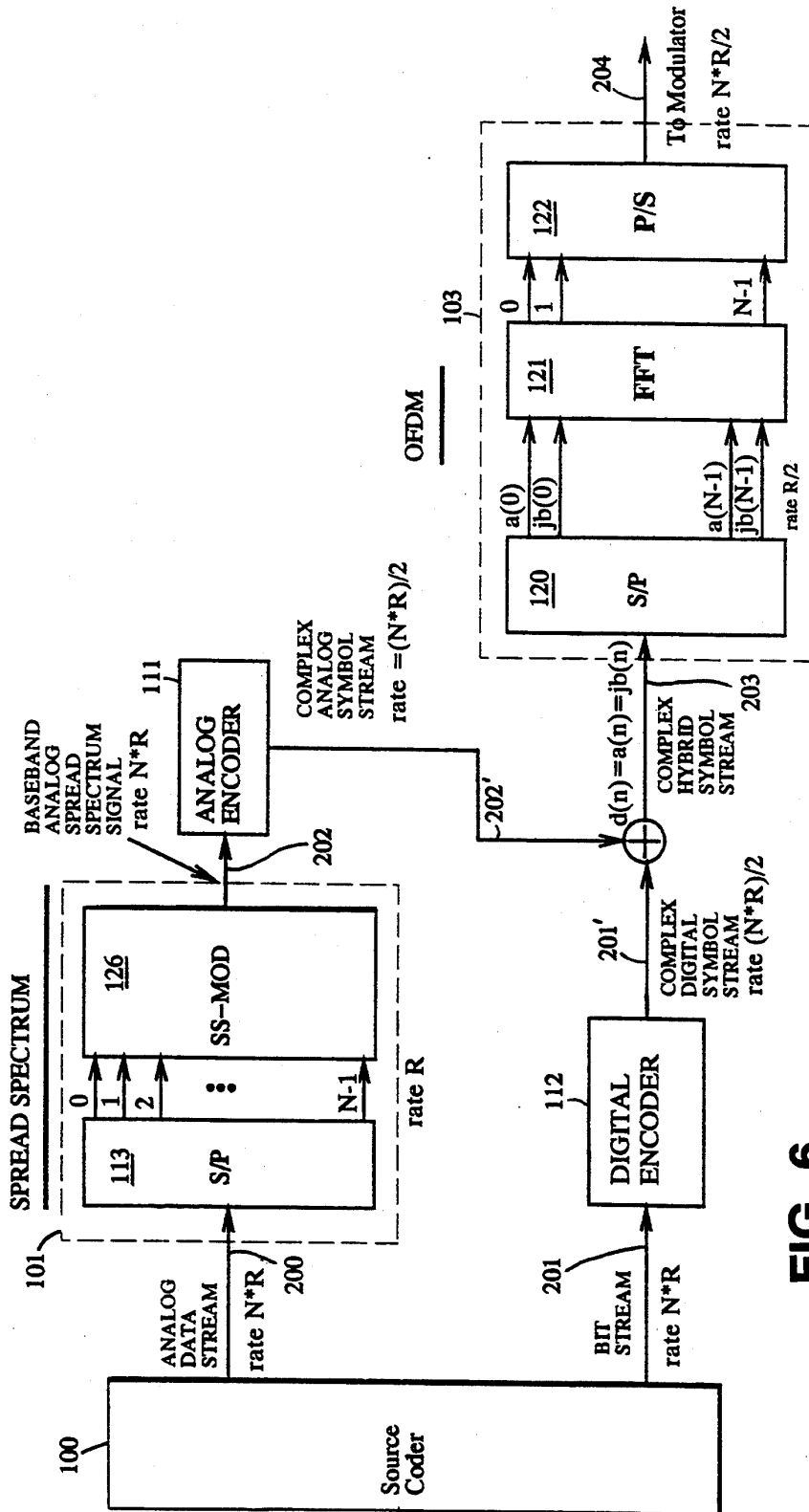

FIG. 6

# Explore Litigation Insights

Docket Alarm provides insights to develop a more informed litigation strategy and the peace of mind of knowing you're on top of things.

## Real-Time Litigation Alerts



Keep your litigation team up-to-date with **real-time alerts** and advanced team management tools built for the enterprise, all while greatly reducing PACER spend.

Our comprehensive service means we can handle Federal, State, and Administrative courts across the country.

## Advanced Docket Research



With over 230 million records, Docket Alarm's cloud-native docket research platform finds what other services can't. Coverage includes Federal, State, plus PTAB, TTAB, ITC and NLRB decisions, all in one place.

Identify arguments that have been successful in the past with full text, pinpoint searching. Link to case law cited within any court document via Fastcase.

## Analytics At Your Fingertips



Learn what happened the last time a particular judge, opposing counsel or company faced cases similar to yours.

Advanced out-of-the-box PTAB and TTAB analytics are always at your fingertips.

## API

Docket Alarm offers a powerful API (application programming interface) to developers that want to integrate case filings into their apps.

## LAW FIRMS

Build custom dashboards for your attorneys and clients with live data direct from the court.

Automate many repetitive legal tasks like conflict checks, document management, and marketing.

## FINANCIAL INSTITUTIONS

Litigation and bankruptcy checks for companies and debtors.

## E-DISCOVERY AND LEGAL VENDORS

Sync your system to PACER to automate legal marketing.