



(19) **United States**

(12) **Patent Application Publication**  
**Amidi**

(10) **Pub. No.: US 2008/0101147 A1**

(43) **Pub. Date: May 1, 2008**

(54) **CLOCK AND POWER FAULT DETECTION FOR MEMORY MODULES**

(52) **U.S. Cl. .... 365/229**

(57) **ABSTRACT**

(76) **Inventor: Hossein Amidi, Lake Forest, CA (US)**

A system, method and apparatus for clock and power fault detection for a memory module is provided. In one embodiment, a system is provided. The system includes a voltage detection circuit and a clock detection circuit. The system further includes a controller coupled to the voltage detection circuit and the clock detection circuit. The system also includes a memory control state machine coupled to the controller. The system includes volatile memory coupled to the memory control state machine. The system further includes a battery and battery regulation circuitry coupled to the controller and the memory control state machine. The battery, battery regulation circuitry, volatile memory, memory control state machine, controller, clock detection circuit and voltage detection circuit are all collectively included in a unitary memory module.

Correspondence Address:  
**PERKINS COIE LLP**  
**P.O. BOX 2168**  
**MENLO PARK, CA 94026**

(21) **Appl. No.: 11/552,949**

(22) **Filed: Oct. 25, 2006**

**Publication Classification**

(51) **Int. Cl. GIIC 5/14 (2006.01)**

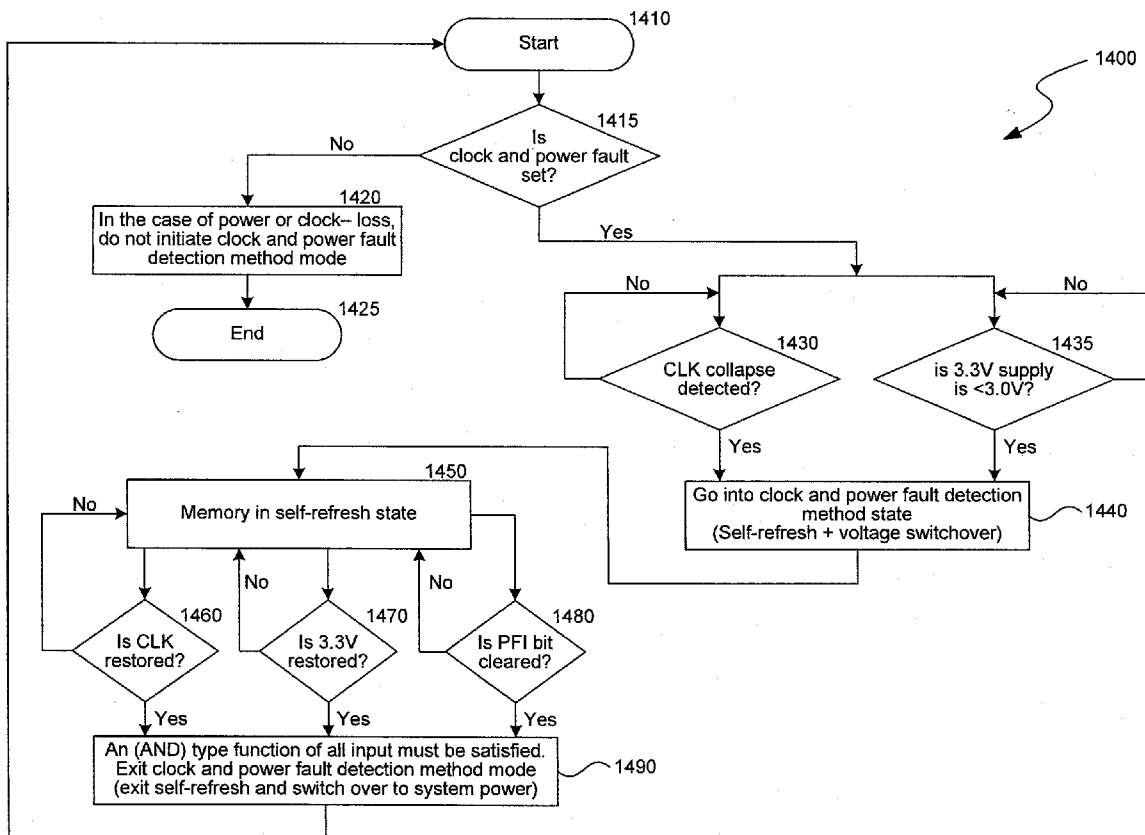

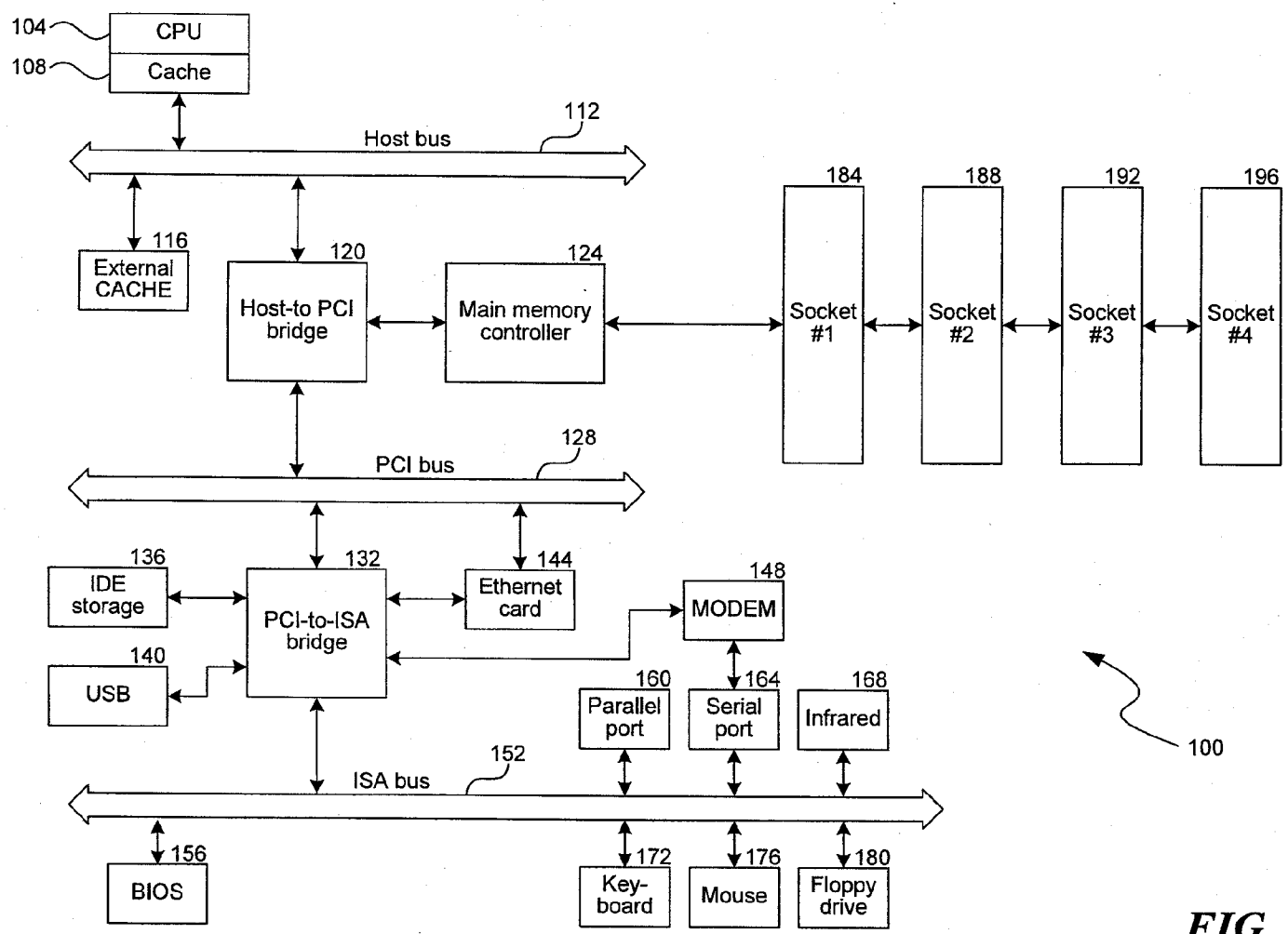

FIG. 1

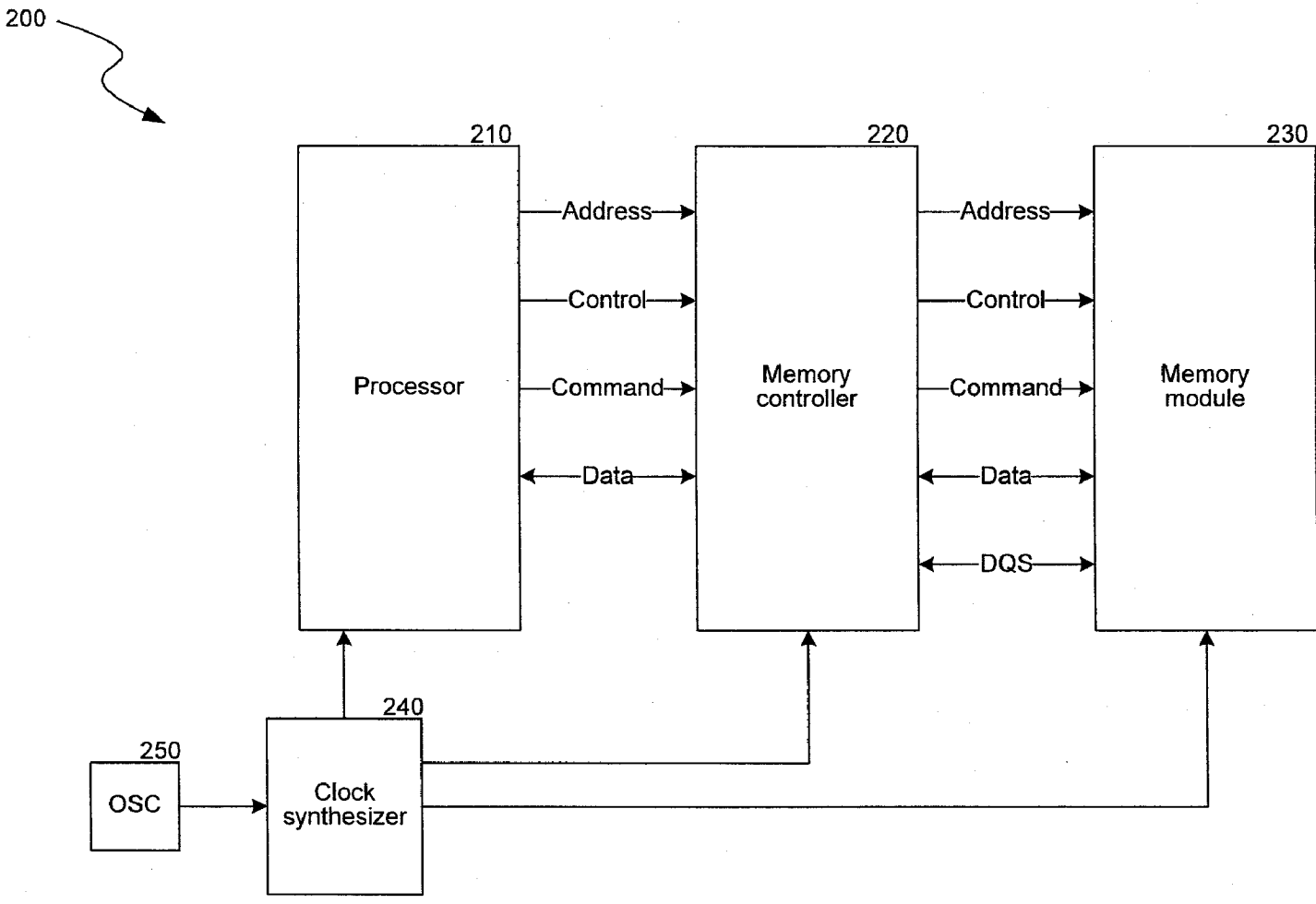

FIG. 2

300

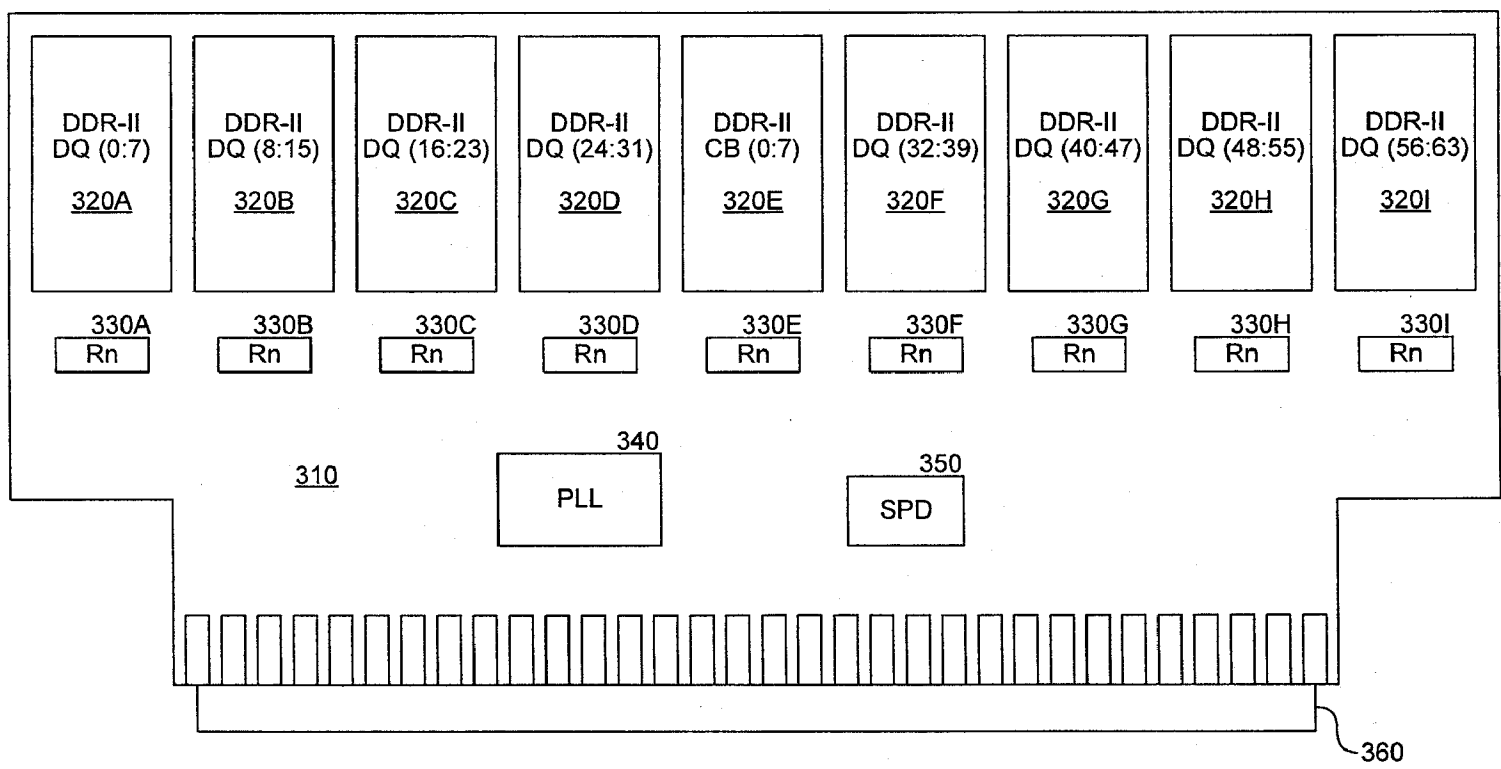

FIG. 3

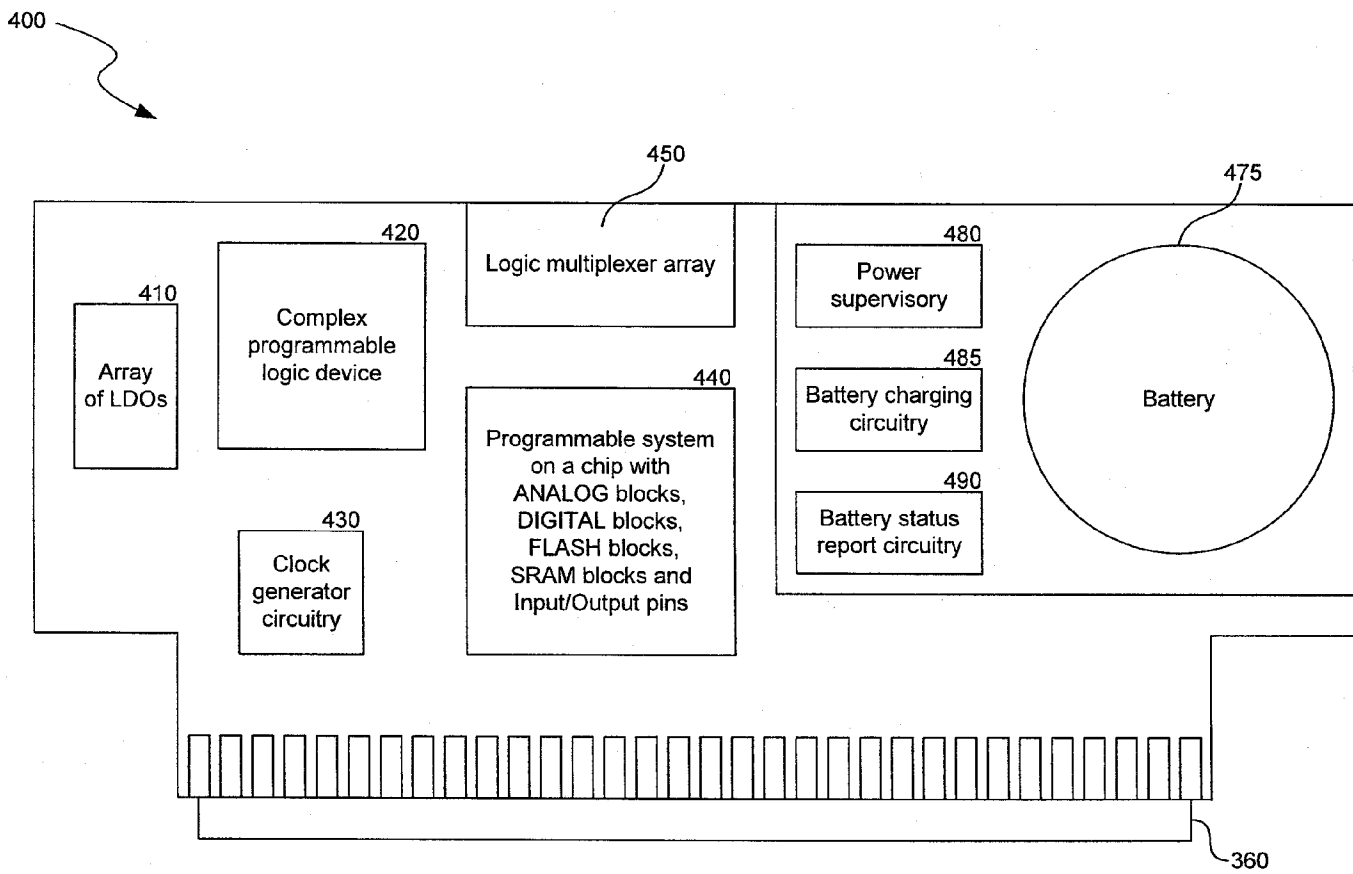

FIG. 4

# Explore Litigation Insights

Docket Alarm provides insights to develop a more informed litigation strategy and the peace of mind of knowing you're on top of things.

## Real-Time Litigation Alerts



Keep your litigation team up-to-date with **real-time alerts** and advanced team management tools built for the enterprise, all while greatly reducing PACER spend.

Our comprehensive service means we can handle Federal, State, and Administrative courts across the country.

## Advanced Docket Research



With over 230 million records, Docket Alarm's cloud-native docket research platform finds what other services can't. Coverage includes Federal, State, plus PTAB, TTAB, ITC and NLRB decisions, all in one place.

Identify arguments that have been successful in the past with full text, pinpoint searching. Link to case law cited within any court document via Fastcase.

## Analytics At Your Fingertips



Learn what happened the last time a particular judge, opposing counsel or company faced cases similar to yours.

Advanced out-of-the-box PTAB and TTAB analytics are always at your fingertips.

## API

Docket Alarm offers a powerful API (application programming interface) to developers that want to integrate case filings into their apps.

## LAW FIRMS

Build custom dashboards for your attorneys and clients with live data direct from the court.

Automate many repetitive legal tasks like conflict checks, document management, and marketing.

## FINANCIAL INSTITUTIONS

Litigation and bankruptcy checks for companies and debtors.

## E-DISCOVERY AND LEGAL VENDORS

Sync your system to PACER to automate legal marketing.