

Simple Soft-Start Circuitry Provides Long Startup Times

[Electronic Design](#)

[Contributing Author](#)

Contributing Author

Mon, 1998-06-22 (All day)

Many dc-dc converters require relatively large amounts of input current at startup (when input power is first applied). A soft-start function minimizes this large input current by gradually increasing the switch-current limit at startup, slowing the rate of rise of the output voltage and reducing the peak current required when starting up.

Some switching-regulator ICs include a short soft-start period (100 μ s to 3 ms), but in some instances the start-up currents are still large enough to cause problems. The major problem occurs when the input power source to the switching regulator is current-limited or has poor load regulation, both of which will cause the input voltage to drop when large startup currents are required.

Because of the negative resistance characteristic associated with the inputs of many switchers, insufficient soft-start time will result in high input currents, causing the input voltage source to be pulled down. With a lower input voltage, the switching regulator requires even more input current to correctly start up. This, in turn, will pull the input voltage lower still, resulting in a latch condition. When in a latch condition, the input current is relatively high, the input voltage is pulled low, and the switching regulator's output never reaches its regulated value. Because of the charging of the output capacitor, this high startup current can exist even without a load on the switcher's output.

Besides minimizing the high startup current associated with switching regulators, a soft-start function also can be used for power supply sequencing. In some situations where multiple regulated voltages are present, it may be necessary for one or more voltages to come up after the main power has come up and stabilized.

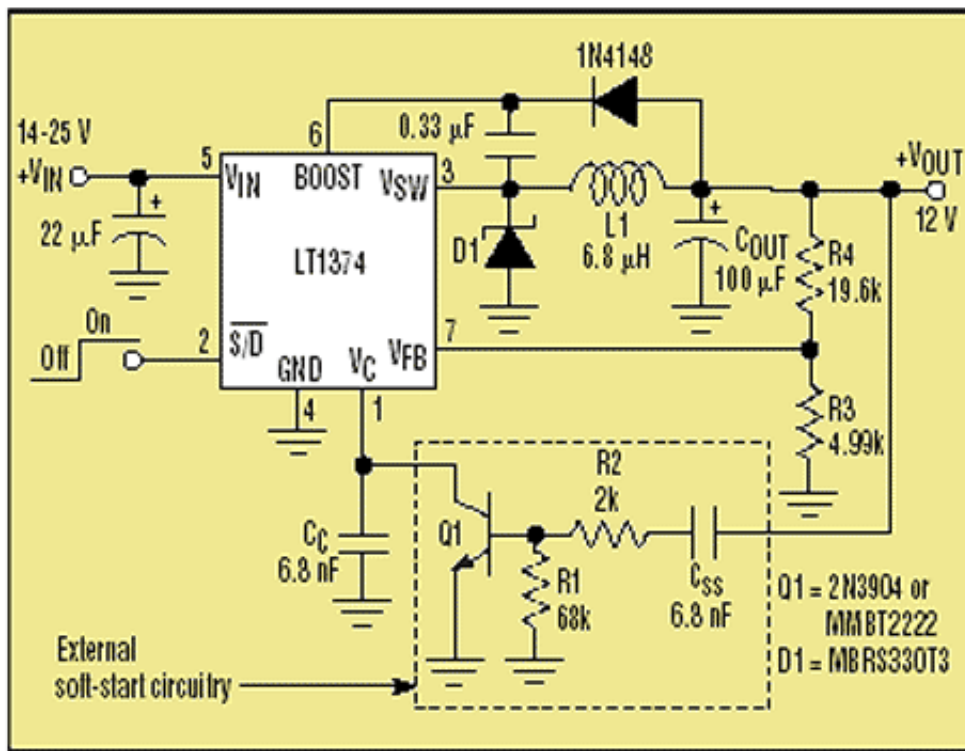

1. To achieve long startup times, external soft-start circuitry is applied to current-limit input of a step-down switching regulator.

The circuit in the dashed box of [Figure 1](#) can be applied to many different types of switching regulators, including buck, boost, flyback, and SEPIC. It provides a soft-start function by slowly increasing the switch current limit, thus controlling the output voltage slew rate. At startup, the output voltage increases linearly, with ramp times ranging from milliseconds to seconds, depending on the capacitor value. The compensation pin (V_C pin) in many current-mode switching-regulator ICs is the output of the error amplifier, which directly controls the maximum current through the switch. By limiting the voltage at the V_C pin, the current can be controlled.

Referring to [Figure 1](#), the circuit operates as follows. At startup, when the input voltage is first applied or when the shutdown input goes high, the regulator output voltage begins to rise. The soft-start capacitor (C_{SS}) begins charging through the emitter-base of Q_1 , causing the collector to begin pulling down on the compensation (V_C) pin (pin 6), thus lowering the switch current limit. Because of this feedback loop, the charge current for the soft-start capacitor is a constant $10\ \mu\text{A}$, which is determined by R_1 (68k) and the V_{BE} ($\approx 680\ \text{mV}$) of Q_1 .

When the regulator's output voltage has stabilized and the soft-start capacitor is charged, the transistor turns off and the switching-regulator circuit operates normally. R_2 limits the discharge current of C_{SS} at powerdown to protect the emitter-base of Q_1 . The following formula can be used to determine the total startup time for various output voltages and soft-start capacitor values:

$$t = C_{SS} * V_{OUT} / 10\ \mu\text{A}$$

The two photos in [Figure 2](#) show the input current and the output voltage of a buck switching-regulator circuit at startup.

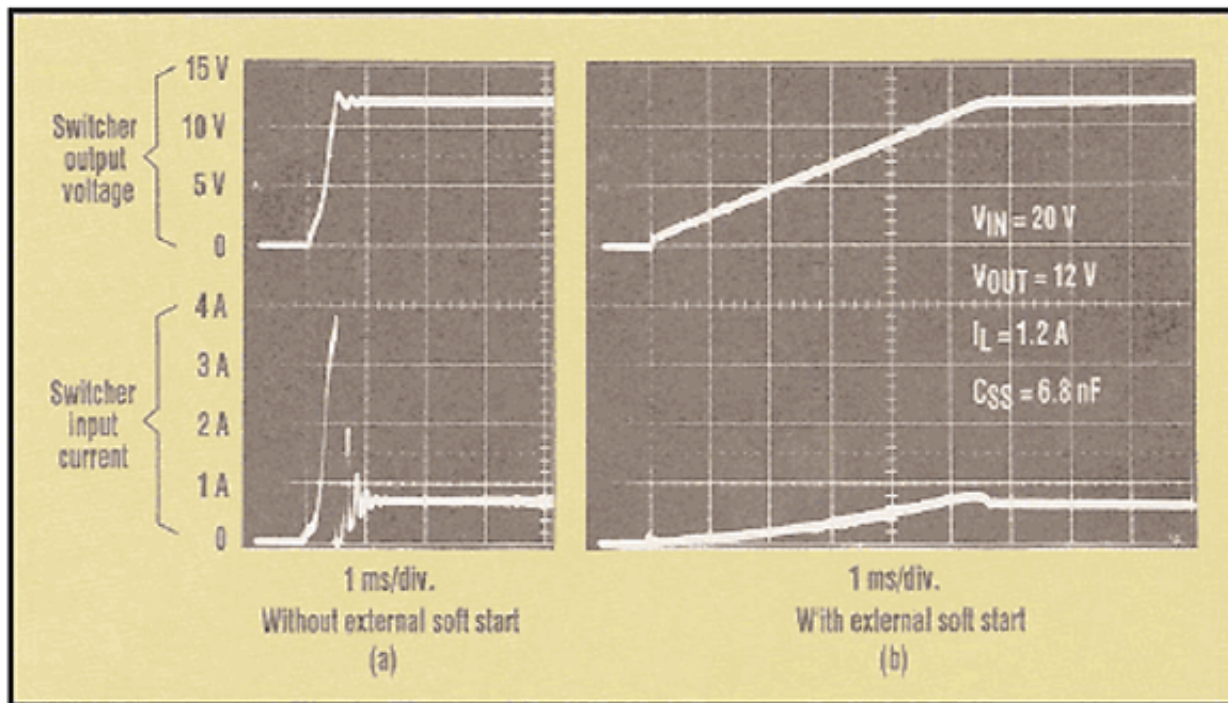

2. Shown is the step-down regulator's output voltage and input current at startup, without (a) and with (b) external soft-start circuitry. Using the soft-start eliminates the 3.8-A surge.

The left photo is the regulator's performance without the external soft-start circuitry, whereas the one on the right shows the effect of the external soft-start circuit of Figure 1. As the right photo illustrates, the 3.8-A input surge current is completely eliminated, while the output voltage increases linearly in approximately 5.5 ms. Other capacitor values can be used if faster or slower rise times are desired. Although a stepdown (buck) regulator configuration was used for the photos, other topologies will provide similar results.

Source URL: <http://electronicdesign.com/power/simple-soft-start-circuitry-provides-long-startup-times>