

3.3V 2M x 64/72-Bit 1 BANK SDRAM Module
3.3V 4M x 64/72-Bit 2 BANK SDRAM Module

HYS64/72V2200GU-8/-10
HYS64/72V4220GU-8/-10

168 pin unbuffered DIMM Modules

- 168 Pin PC100 and PC66 compatible unbuffered 8 Byte Dual-In-Line SDRAM Modules for PC main memory applications
- 1 bank 2M x 64, 2M x 72 and 2 bank 4M x 64, 4M x 72 organisation
- Optimized for byte-write non-parity or ECC applications
- JEDEC standard Synchronous DRAMs (SDRAM)
- Fully PC board layout compatible to INTEL's Rev. 1.0 module specification
- SDRAM Performance:

		-8	-8-3	-10	Units
f _{CK}	Clock frequency (max.)	100	100	66	MHz
t _{AC}	Clock access time	6	6	8	ns

- Programmed Latencies :

Product Speed		CL	tRCD	tRP
-8	PC100	2	2	2
-8-3	PC100	3	2	3
-10	PC66	2	2	2

- Single +3.3V(± 0.3V) power supply
- Programmable $\overline{\text{CAS}}$ Latency, Burst Length and Wrap Sequence (Sequential & Interleave)
- Auto Refresh (CBR) and Self Refresh
- Decoupling capacitors mounted on substrate
- All inputs, outputs are LVTTTL compatible
- Serial Presence Detect with E²PROM
- Utilizes 2M x 8 SDRAMs in TSOPII-44 packages
- 4096 refresh cycles every 64 ms
- 133,35 mm x 31.75 mm x 4,00 mm card size with gold contact pads

The HYS64(72)2200 and HYS64(72)4220 are industry standard 168-pin 8-byte Dual in-line Memory Modules (DIMMs) which are organised as 2M x 64, 2M x 72 in 1 bank and 4M x 64 and 4M x 72 in two banks high speed memory arrays designed with Synchronous DRAMs (SDRAMs) for non-parity and ECC applications. The DIMMs use -8 speed sort 2M x 8 SDRAM devices in TSOP44 packages to meet the PC100 requirement. Modules which use -10 parts are suitable for PC66 applications only. Decoupling capacitors are mounted on the PC board. The PC board design is according to INTEL'S PC SDRAM Rev.1.0 module specification.

The DIMMs have a serial presence detect, implemented with a serial E²PROM using the two pin I²C protocol. The first 128 bytes are utilized by the DIMM manufacturer and the second 128 bytes are available to the end user.

All SIEMENS 168-pin DIMMs provide a high performance, flexible 8-byte interface in a 133,35 mm long footprint, with 1,25" (31,75 mm) height

Ordering Information

Type	Ordering Code	Package	Descriptions	Module Height
HYS 64V2200GU-8	PC100-222-620	L-DIM-168-29	100 Mhz 2M x 64 1 bank SDRAM module	1,25"
HYS 72V2200GU-8	PC100-222-620	L-DIM-168-29	100 MHz 2M x 72 1 bank SDRAM module	1,25"
HYS 64V4220GU-8	PC100-222-620	L-DIM-168-29	100 Mhz 4M x 64 2 bank SDRAM module	1,25"
HYS 72V4220GU-8	PC100-222-620	L-DIM-168-29	100 Mhz 4M x 72 2 bank SDRAM module	1,25"
HYS 64V2200GU-8-3	PC100-323-620	L-DIM-168-29	100 Mhz 2M x 64 1 bank SDRAM module	1,25"
HYS 72V2200GU-8-3	PC100-323-620	L-DIM-168-29	100 MHz 2M x 72 1 bank SDRAM module	1,25"
HYS 64V4220GU-8-3	PC100-323-620	L-DIM-168-29	100 Mhz 4M x 64 2 bank SDRAM module	1,25"
HYS 72V4220GU-8-3	PC100-323-620	L-DIM-168-29	100 Mhz 4M x 72 2 bank SDRAM module	1,25"
HYS 64V2200GU-10	PC66-222-920	L-DIM-168-29	66 Mhz 2M x 64 1 bank SDRAM module	1,25"
HYS 72V2200GU-10	PC66-222-920	L-DIM-168-29	66 MHz 2M x 72 1 bank SDRAM module	1,25"
HYS 64V4220GU-10	PC66-222-920	L-DIM-168-29	66 Mhz 4M x 64 2 bank SDRAM module	1,25"
HYS 72V4220GU-10	PC66-222-920	L-DIM-168-29	66 Mhz 4M x 72 2 bank SDRAM module	1,25"

Pin Names

A0-A10	Address Inputs	CLK0 - CLK3	Clock Input
BA	Bank Address	DQMB0 - DQMB7	Data Mask
DQ0 - DQ63	Data Input/Output	CS0 - CS3	Chip Select
CB0-CB7	Check Bits (x72 organisation only)	Vcc	Power (+3.3 Volt)
RAS	Row Address Strobe	Vss	Ground
CAS	Column Address Strobe	SCL	Clock for Presence Detect
WE	Read / Write Input	SDA	Serial Data Out for Presence Detect
CKE0, CKE1	Clock Enable	N.C.	No Connection

Address Format:

	Part Number	Rows	Columns	Banks	Refresh	Period	Interval
2M x 64	HYS 64V2200GU	11	9	1	4k	64 ms	15,6 µs
2M x 72	HYS 72V2200GU	11	9	1	4k	64 ms	15,6 µs
4M x 64	HYS 64V4220GU	11	9	1	4k	64 ms	15,6 µs
4M x 72	HYS 72V4220GU	11	9	1	4k	64 ms	15,6 µs

Pin Configuration

PIN #	Symbol	PIN #	Symbol	PIN #	Symbol	PIN #	Symbol
1	VSS	43	VSS	85	VSS	127	VSS
2	DQ0	44	DU	86	DQ32	128	CKE0
3	DQ1	45	CS2	87	DQ33	129	CS3
4	DQ2	46	DQMB2	88	DQ34	130	DQMB6
5	DQ3	47	DQMB3	89	DQ35	131	DQMB7
6	VCC	48	DU	90	VCC	132	NC
7	DQ4	49	VCC	91	DQ36	133	VCC
8	DQ5	50	NC	92	DQ37	134	NC
9	DQ6	51	NC	93	DQ38	135	NC
10	DQ7	52	NC (CB2)	94	DQ39	136	CB6
11	DQ8	53	NC (CB3)	95	DQ40	137	CB7
12	VSS	54	VSS	96	VSS	138	VSS
13	DQ9	55	DQ16	97	DQ41	139	DQ48
14	DQ10	56	DQ17	98	DQ42	140	DQ49
15	DQ11	57	DQ18	99	DQ43	141	DQ50
16	DQ12	58	DQ19	100	DQ44	142	DQ51
17	DQ13	59	VCC	101	DQ45	143	VCC
18	VCC	60	DQ20	102	VCC	144	DQ52
19	DQ14	61	NC	103	DQ46	145	NC
20	DQ15	62	DU	104	DQ47	146	DU
21	NC (CB0)	63	CKE1	105	NC (CB4)	147	NC
22	NC (CB1)	64	VSS	106	NC (CB5)	148	VSS
23	VSS	65	DQ21	107	VSS	149	DQ53
24	NC	66	DQ22	108	NC	150	DQ54
25	NC	67	DQ23	109	NC	151	DQ55
26	VCC	68	VSS	110	VCC	152	VSS
27	WE	69	DQ24	111	CAS	153	DQ56
28	DQMB0	70	DQ25	112	DQMB4	154	DQ57
29	DQMB1	71	DQ26	113	DQMB5	155	DQ58
30	CS0	72	DQ27	114	CS1	156	DQ59
31	DU	73	VCC	115	RAS	157	VCC
32	VSS	74	DQ28	116	VSS	158	DQ60
33	A0	75	DQ29	117	A1	159	DQ61
34	A2	76	DQ30	118	A3	160	DQ62
35	A4	77	DQ31	119	A5	161	DQ63
36	A6	78	VSS	120	A7	162	VSS
37	A8	79	CLK2	121	A9	163	CLK3
38	A10	80	NC	122	BA	164	NC
39	NC	81	WP	123	NC	165	SA0
40	VCC	82	SDA	124	VCC	166	SA1
41	VCC	83	SCL	125	CLK1	167	SA2
42	CLK0	84	VCC	126	NC	168	VCC

Note : Pinnames in brackets are for the x72 ECC versions

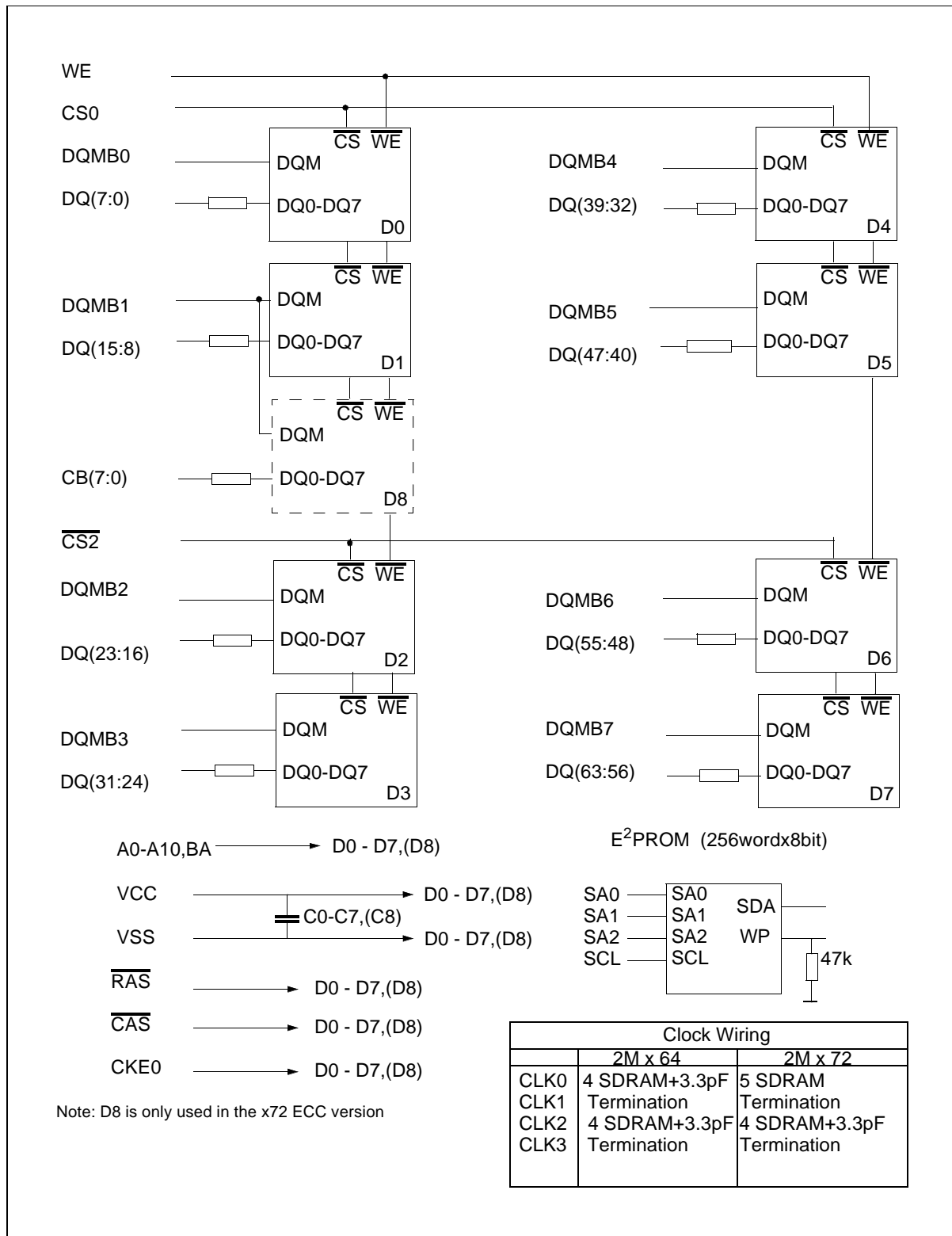

Block Diagram for 2M x 64/72 SDRAM DIMM modules (HYS64/72V2200GU)

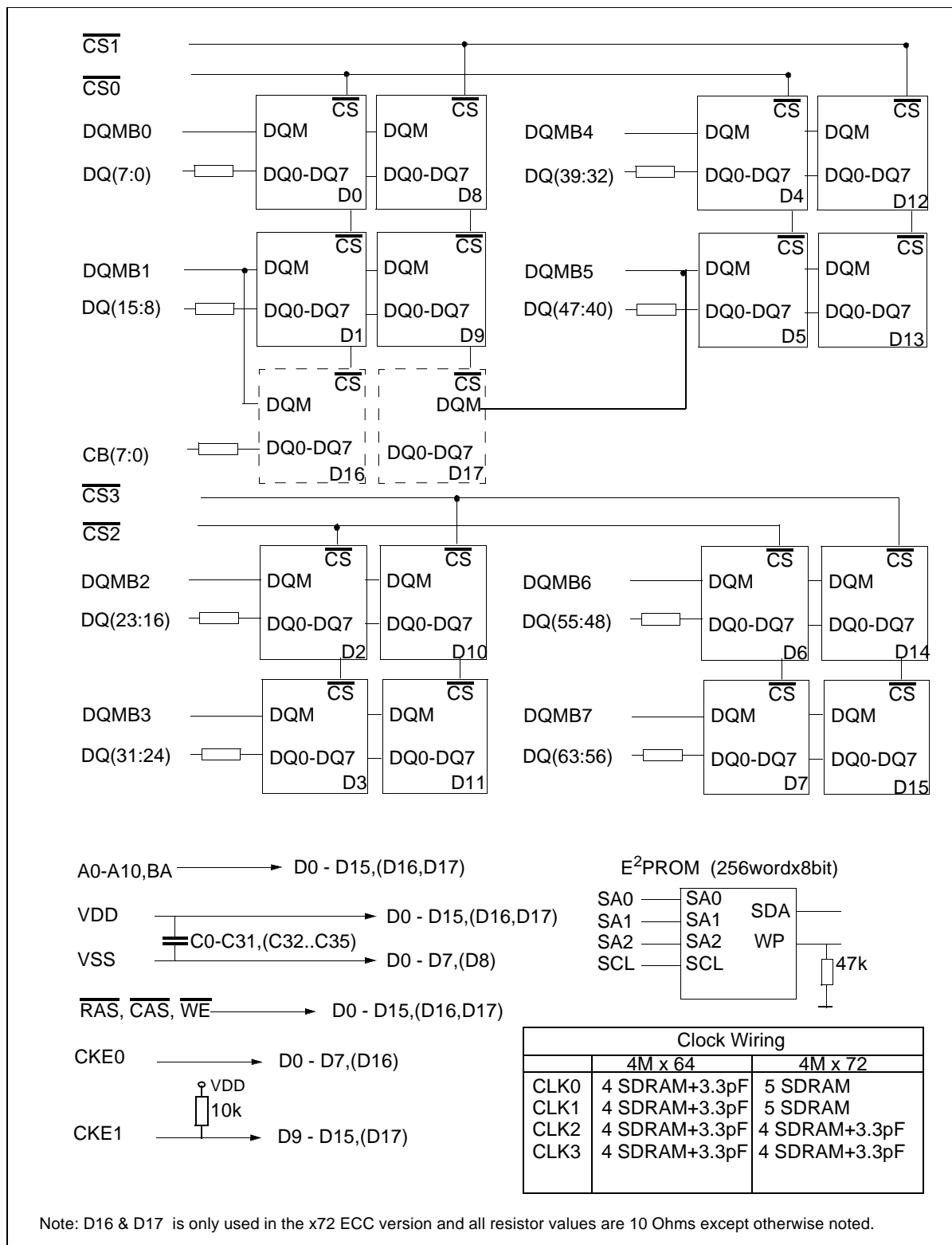

Block Diagram for 4M x 64/72 SDRAM DIMM modules (HYS64/72V4220GU)

Explore Litigation Insights

Docket Alarm provides insights to develop a more informed litigation strategy and the peace of mind of knowing you're on top of things.

Real-Time Litigation Alerts



Keep your litigation team up-to-date with **real-time alerts** and advanced team management tools built for the enterprise, all while greatly reducing PACER spend.

Our comprehensive service means we can handle Federal, State, and Administrative courts across the country.

Advanced Docket Research



With over 230 million records, Docket Alarm's cloud-native docket research platform finds what other services can't. Coverage includes Federal, State, plus PTAB, TTAB, ITC and NLRB decisions, all in one place.

Identify arguments that have been successful in the past with full text, pinpoint searching. Link to case law cited within any court document via Fastcase.

Analytics At Your Fingertips



Learn what happened the last time a particular judge, opposing counsel or company faced cases similar to yours.

Advanced out-of-the-box PTAB and TTAB analytics are always at your fingertips.

API

Docket Alarm offers a powerful API (application programming interface) to developers that want to integrate case filings into their apps.

LAW FIRMS

Build custom dashboards for your attorneys and clients with live data direct from the court.

Automate many repetitive legal tasks like conflict checks, document management, and marketing.

FINANCIAL INSTITUTIONS

Litigation and bankruptcy checks for companies and debtors.

E-DISCOVERY AND LEGAL VENDORS

Sync your system to PACER to automate legal marketing.