

**UNITED STATES DISTRICT COURT  
FOR THE WESTERN DISTRICT OF TEXAS  
WACO DIVISION**

AIRE TECHNOLOGY LTD.,

Plaintiff,

v.

SAMSUNG ELECTRONICS CO., LTD. and  
SAMSUNG ELECTRONICS AMERICA, INC.,

Defendants.

Case No. 6:21-cv-00955

**JURY TRIAL DEMANDED**

**COMPLAINT FOR PATENT INFRINGEMENT  
AGAINST SAMSUNG ELECTRONICS CO., LTD AND  
SAMSUNG ELECTRONICS AMERICA, INC.**

This is an action for patent infringement arising under the Patent Laws of the United States of America, 35 U.S.C. § 1 *et seq.*, in which Plaintiff Aire Technology Limited (“Plaintiff” or “Aire”) makes the following allegations against Defendants Samsung Electronics Co., Ltd. and Samsung Electronics America, Inc. (collectively, “Defendants” or “Samsung”):

**INTRODUCTION**

1. This complaint arises from Samsung’s unlawful infringement of the following United States patents owned by Plaintiff, which relate to improvements in Near Field Communication (NFC) and secure digital payment solutions: United States Patent Nos. 8,581,706 (“the ’706 Patent”), 8,816,827 (“the ’827 Patent”), 8,205,249 (“the ’249 Patent”), and 8,174,360 (“the ’360 Patent”) (collectively, the “Asserted Patents”).

**PARTIES**

2. Plaintiff Aire Technology Limited is a limited liability company organized and existing under the law of Ireland, with its principal place of business at The Hyde Building, Suite

23, The Park, Carrickmines, Dublin 18, Ireland. Aire is the sole owner by assignment of all rights, title, and interest in the Asserted Patents, including the right to recover damages for past, present, and future infringement.

3. On information and belief, Defendant Samsung Electronics Co., Ltd. is a corporation organized under the laws of South Korea, with its principal place of business at 129 Samsung-ro, Maetan-dong, Yeongtong-gu, Suwon-si, Gyeonggi-do, 443-742, South Korea.

4. On information and belief, Defendant Samsung Electronics America, Inc., a wholly owned subsidiary of Samsung Electronics Co., Ltd., is a corporation organized under the laws of the State of New York, with its principal place of business at 85 Challenger Rd., Ridgefield Park, New Jersey 07660.

#### **JURISDICTION AND VENUE**

5. This action arises under the patent laws of the United States, Title 35 of the United States Code. This Court has original subject matter jurisdiction pursuant to 28 U.S.C. §§ 1331 and 1338(a).

6. This Court has personal jurisdiction over Samsung in this action because Samsung has committed acts within this District giving rise to this action and has established minimum contacts with this forum such that the exercise of jurisdiction over Samsung would not offend traditional notions of fair play and substantial justice. Samsung, directly and through subsidiaries or intermediaries, has committed and continues to commit acts of infringement in this District by, among other things, importing, offering to sell, and selling products that infringe the Asserted Patents.

7. Venue is proper in this District under 28 U.S.C. §§ 1391 and 1400(b). Defendant Samsung Electronics America, Inc. is registered to do business in Texas. Additionally, upon

information and belief, Defendants have transacted business in this District and have committed acts of direct and indirect infringement in this District by, among other things, making, using, offering to sell, selling, and importing products that infringe the Asserted Patents. Defendants have regular and established places of businesses in this District, including at 12100 Samsung Boulevard, Austin, Texas 78754; 7300 Ranch Road 2222, Austin, Texas 78730; and 1700 Scenic Loop, Round Rock, Texas 78681. *See* Exhibits 1-3. Additionally, venue is proper as to a foreign defendant in any district. 28 U.S.C. § 1391(c)(3); *In re HTC Corp.*, 889 F.3d 1349 (Fed. Cir. 2018). Defendant Samsung Electronics Co., Ltd. is a foreign corporation organized under the laws of Korea, with a principal place of business in Korea.

#### **THE ASSERTED PATENTS**

8. On November 12, 2013, the United States Patent and Trademark Office issued U.S. Patent No. 8,581,706 (“the ’706 Patent”), entitled “Data storage medium and method for contactless communication between the data storage medium and a reader,” after full and fair examination. Plaintiff is the assignee of all rights, title, and interest in and to the ’706 Patent and possesses all rights of recovery under the ’706 Patent, including the right to recover damages for past, present, and future infringement. The ’706 Patent is valid and enforceable. A true and correct copy of the ’706 Patent is attached hereto as Exhibit 4.

9. On August 26, 2014, the United States Patent and Trademark Office issued U.S. Patent No. 8,816,827 (“the ’827 Patent”), entitled “Data storage medium and method for contactless communication between the data storage medium and a reader,” after full and fair examination. Plaintiff is the assignee of all rights, title, and interest in and to the ’827 Patent and possesses all rights of recovery under the ’827 Patent, including the right to recover damages for

past, present, and future infringement. The '827 Patent is valid and enforceable. A true and correct copy of the '827 Patent is attached hereto as Exhibit 5.

10. On June 19, 2012, the United States Patent and Trademark Office issued U.S. Patent No. 8,205,249 (“the '249 Patent”), entitled “Method for carrying out a secure electronic transaction using a portable data support,” after full and fair examination. Plaintiff is the assignee of all rights, title, and interest in and to the '249 Patent and possesses all rights of recovery under the '249 Patent, including the right to recover damages for past, present, and future infringement. The '249 Patent is valid and enforceable. A true and correct copy of the '249 Patent is attached hereto as Exhibit 6.

11. On May 8, 2012, the United States Patent and Trademark Office issued U.S. Patent No. 8,174,360 (“the '360 Patent”), entitled “Communication apparatus for setting up a data connection between intelligent devices,” after full and fair examination. Plaintiff is the assignee of all rights, title, and interest in and to the '360 Patent and possesses all rights of recovery under the '360 Patent, including the right to recover damages for past, present, and future infringement. The '360 Patent is valid and enforceable. A true and correct copy of the '360 Patent is attached hereto as Exhibit 7.

### **SAMSUNG’S INFRINGEMENT**

12. The allegations provided below are exemplary and without prejudice to Plaintiff’s infringement contentions provided pursuant to the Court’s scheduling order and local rules. Plaintiff’s claim construction contentions regarding the meaning and scope of the claim terms will be provided under the Court’s scheduling order and local rules. As detailed below, each element of at least one claim of each of the Asserted Patents is literally present in the accused products. To the extent that any element is not literally present, each such element is present under the doctrine

of equivalents. Plaintiff's analysis below should not be taken as an admission that the preamble is limiting. While publicly available information is cited below, Plaintiff may rely on other forms of evidence to prove infringement, including evidence that is solely in the possession of Samsung and/or third parties.

13. The accused products include at least the following products, as well as products with reasonably similar functionality and all Edge, Plus (+), Active, and SIM varieties of these products. Identification of the accused products will be provided in Plaintiff's infringement contentions pursuant to the Court's scheduling order and local rules. Samsung imports, uses, makes, offers for sale, and sells in the United States the following products that support NFC and/or mobile payment applications, such as Samsung Pay and Google Pay, that infringe at least one claim of the Asserted Patents: Galaxy S6, S6 Edge, S6 Edge +, S6 Active, S7, S7 Edge, S7 Active, S8, S8+, S9, S9+, S10, S10+, S10e, S10 5G, S20, S20 +, S20 Ultra, S21, S21+, S21 Ultra, Note 5, Note 7, Note FE, Note 8, Note 9, Note 10, Note 10+, Note 10 5G, Note 20, Note 20 Ultra, A50, A51, A51 5G, A71 5G, A52 5G, A42 5G, A32 5G, Fold, Fold 2 5G, Fold 3 5G, Flip, Flip 5G, Flip 3 5G, Watch, Watch 3, Watch 4, Watch Active, Watch Active2, Gear Sport, Gear S2 Classic, Gear S2 Sport, Gear S3 Classic, and Gear S3 Frontier (the "Accused Products"). See <https://www.samsung.com/us/support/owners/app/samsung-pay>.

## **COUNT I**

### **INFRINGEMENT OF U.S. PATENT NO. 8,581,706**

14. Plaintiff realleges and incorporates by reference the foregoing paragraphs as if fully set forth herein.

15. Samsung has been and is now directly infringing the '706 Patent, literally and/or under the doctrine of equivalents, in violation of 35 U.S.C. § 271(a), including by making, using,

selling, and/or offering for sale in the United States or importing into the United States infringing products, including at least the Accused Products identified above. The Accused Products satisfy all of the claim limitations of one or more claims of the '706 Patent, including but not limited to claim 11.

16. Claim 11 of the '706 Patent recites a “contactlessly communicating portable data carrier.” To the extent the preamble is limiting, the Accused Products each include a portable data carrier that is capable of contactless communication through the use of Near Field Communication (NFC) technology. For example, Samsung advertises that the Accused Products support NFC:

Network & Connectivity	Galaxy S21 5G and S21+ 5G	Galaxy S21 Ultra 5G
	<b>5G</b> 5G Non-Standalone (NSA), Standalone (SA), Sub6 / mmWave	<b>5G</b> 5G Non-Standalone (NSA), Standalone (SA), Sub6 / mmWave
	<b>LTE</b> Enhanced 4x4 MIMO, Up to 7CA, LTE Cat.20 Up to 2.0Gbps Download / Up to 200Mbps Upload	<b>LTE</b> Enhanced 4x4 MIMO, Up to 7CA, LTE Cat.20 Up to 2.0Gbps Download / Up to 200Mbps Upload
	<b>Wi-Fi</b> Wi-Fi 802.11 a/b/g/n/ac/ax 2.4G+5GHz, HE80, MIMO, 1024-QAM Up to 1.2Gbps Download / Up to 1.2Gbps Upload	<b>Wi-Fi</b> Wi-Fi 802.11 a/b/g/n/ac/ax 2.4G+5GHz+6GHz, HE160, MIMO, 1024-QAM Up to 2.4Gbps Download / Up to 2.4Gbps Upload
	<b>Bluetooth</b> Bluetooth® v 5.0, USB type-C, NFC, Location (GPS, Galileo, Glonass, BeiDou)	<b>Bluetooth</b> Bluetooth® v 5.2, USB type-C, NFC, Location (GPS, Galileo, Glonass, BeiDou)

**Samsung Pay**

- Credit & debit cards: supports MST and/or NFC
- Membership cards
- Gift cards
- Transit cards

See <https://www.samsung.com/global/galaxy/galaxy-s21-ultra-5g/specs/>.

17. Claim 11 of the '706 Patent recites that the portable data carrier comprises “at least two applications stored thereon.” The Accused Products are configured to store at least two

applications. For example, the Accused Products are configured to store at least two applications that utilize NFC:

### Service selection

When the user taps a device to an NFC reader, the Android system needs to know which HCE service the NFC reader wants to communicate with. The ISO/IEC 7816-4 specification defines a way to select applications, centered around an Application ID (AID). An AID consists of up to 16 bytes. If you are emulating cards for an existing NFC reader infrastructure, the AIDs that those readers look for are typically well-known and publicly registered (for example, the AIDs of payment networks such as Visa and MasterCard).

If you want to deploy new reader infrastructure for your own application, you must register your own AIDs. The registration procedure for AIDs is defined in the ISO/IEC 7816-5 specification. We recommend registering an AID as per 7816-5 if you are deploying a HCE application for Android, because it avoids collisions with other applications.

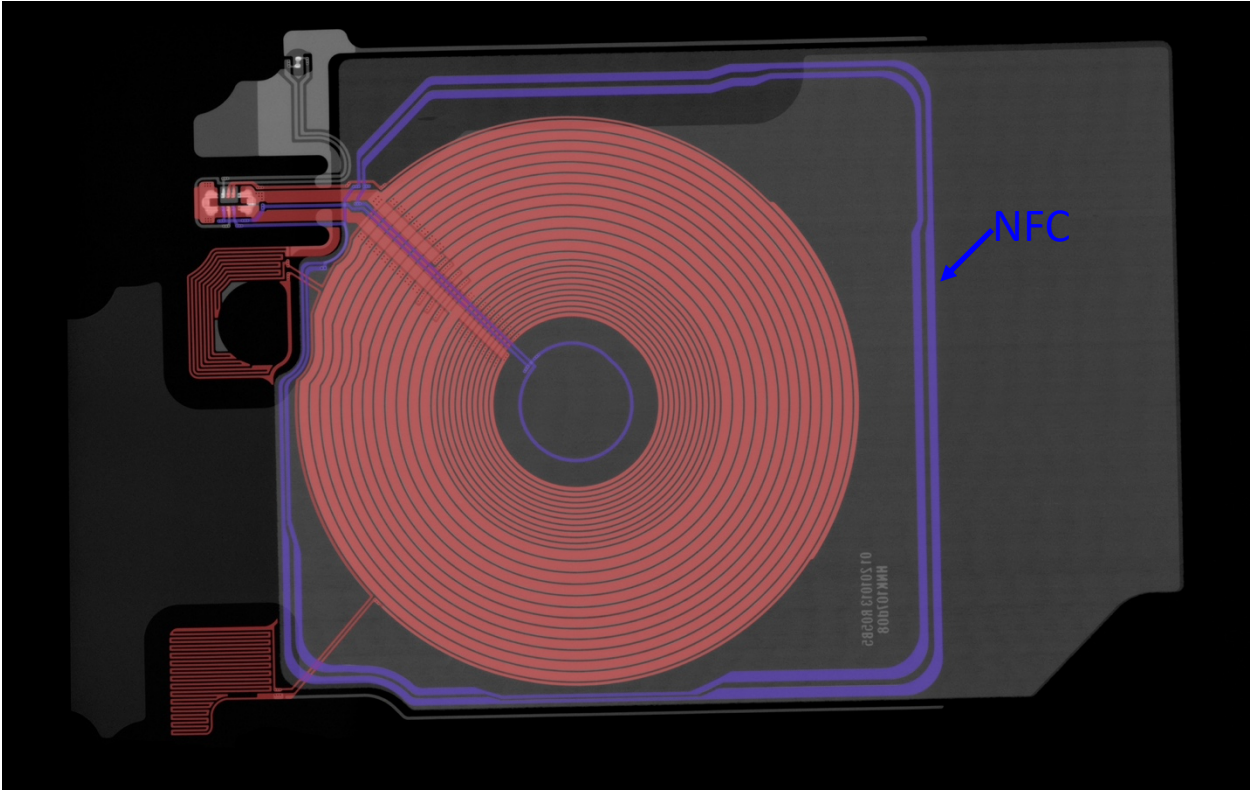
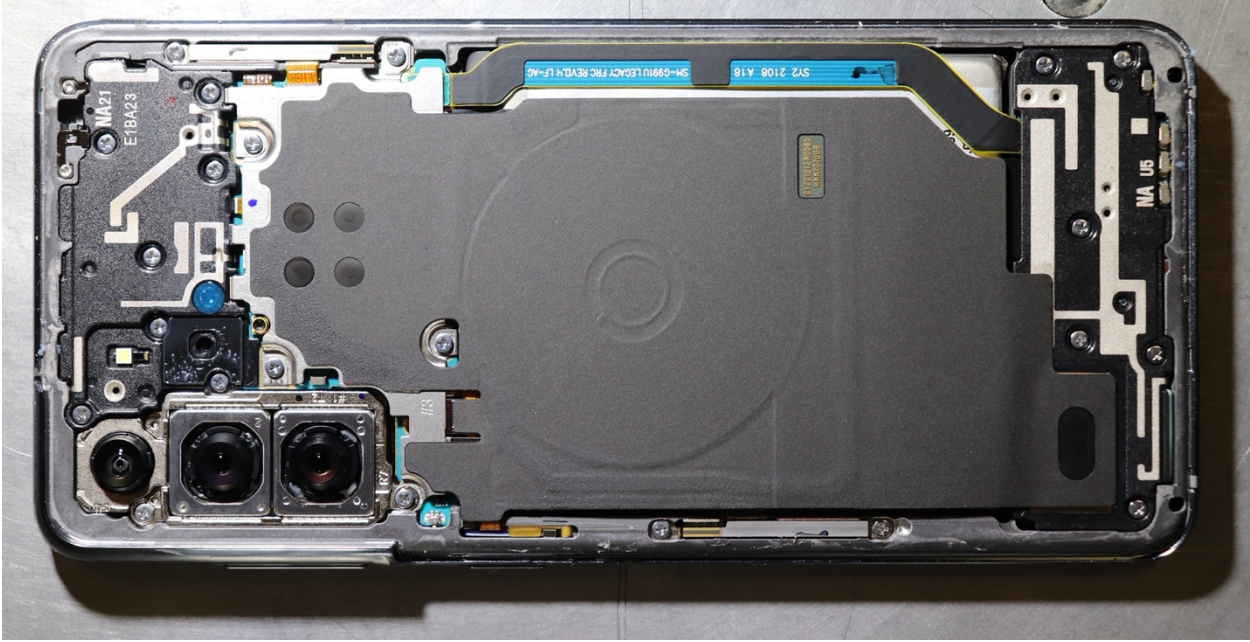
### AID conflict resolution

Multiple `HostApduService` components may be installed on a single device, and the same AID can be registered by more than one service. Android resolves AID conflicts differently depending on which category an AID belongs to. Each category may have a different conflict resolution policy.

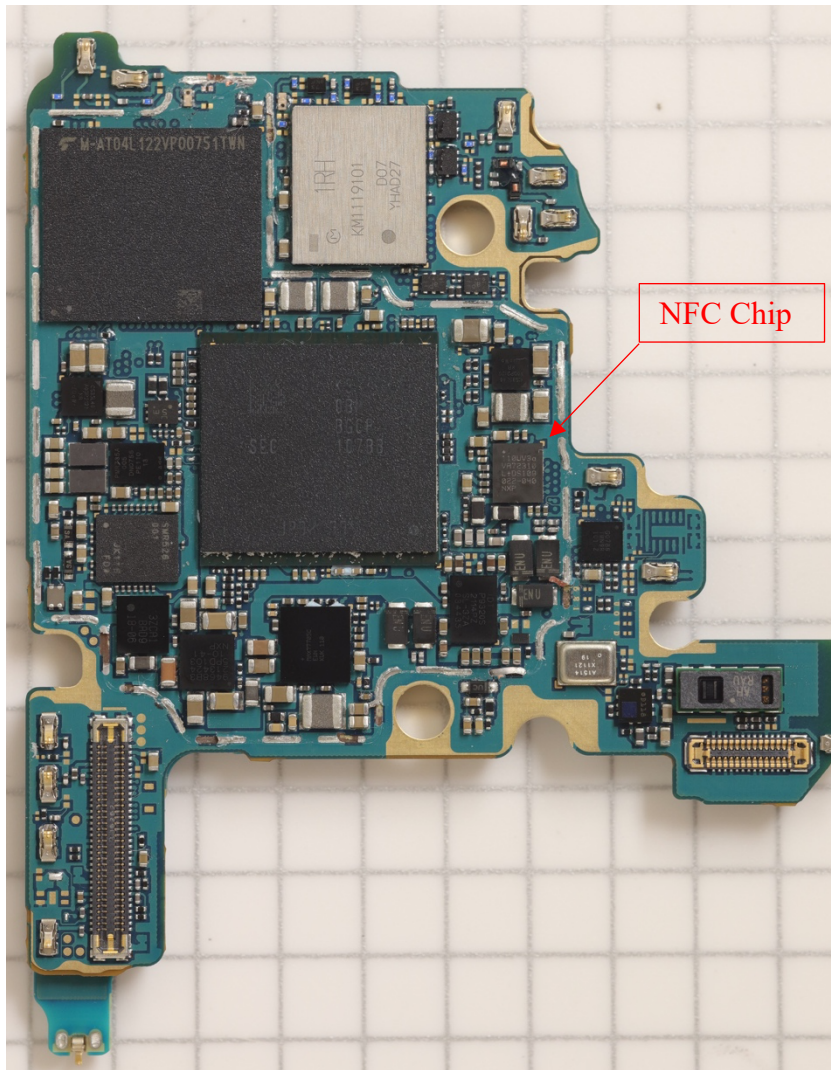
For some categories, such as payment, the user might be able to select a default service in the Android settings UI. For other categories, the policy might be to always ask the user which service to invoke in case of conflict. For information about how to query the conflict resolution policy for a certain category, see `getSelectionModeForCategory()`.

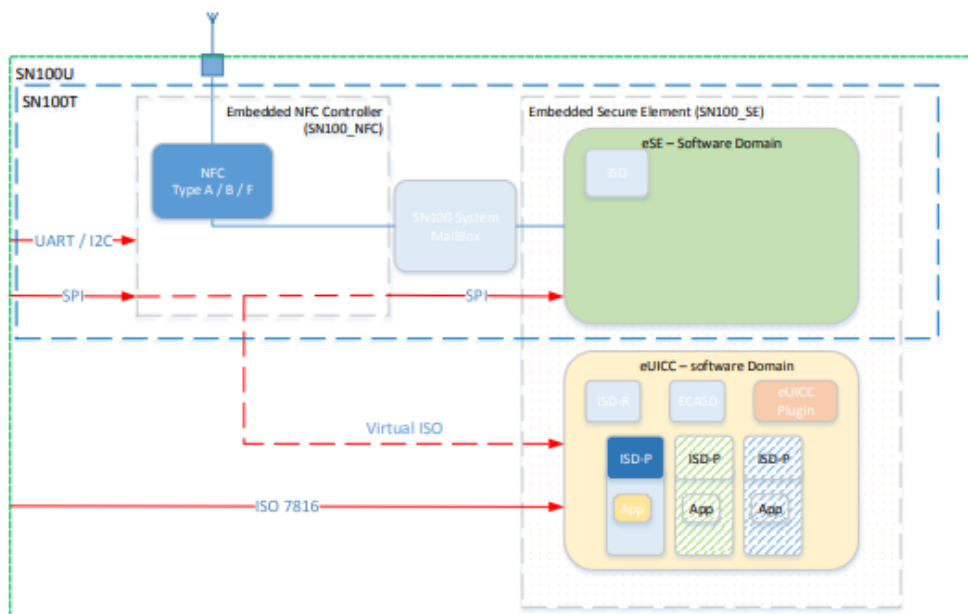
See <https://developer.android.com/guide/topics/connectivity/nfc/hce>.

18. Claim 11 of the '706 Patent recites that the portable data carrier comprises “a communication device configured to control communication between a reading device and the at least two applications.” The Accused Products contain a communication device configured to control communication between a reading device and at least two applications. For example, the Accused Products utilize an NFC antenna, NFC chip, and related hardware and software to control communication with a reading device and at least two applications, as shown in the exemplary Samsung S21:



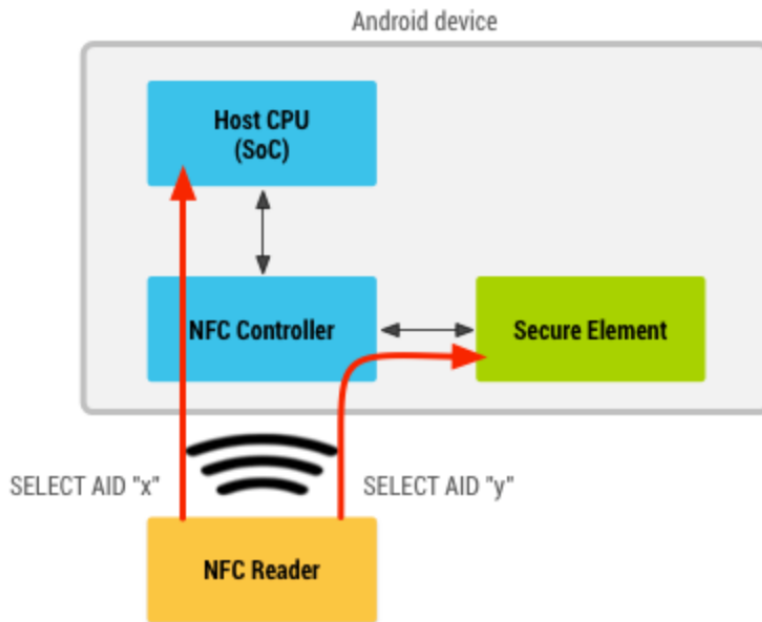






**Fig. 1.2: SN100x Product Configurations**

See [https://www.commoncriteriaportal.org/files/epfiles/SecurityTarget-Lite\\_SN100T\\_v1.1\\_20190418.pdf](https://www.commoncriteriaportal.org/files/epfiles/SecurityTarget-Lite_SN100T_v1.1_20190418.pdf); see also [https://www.emvco.com/wp-content/uploads/approved\\_products/uploaded/loa/MTA\\_LOA\\_SAE\\_L\\_02859\\_24Nov20\\_SHORT.pdf](https://www.emvco.com/wp-content/uploads/approved_products/uploaded/loa/MTA_LOA_SAE_L_02859_24Nov20_SHORT.pdf).



See <https://developer.android.com/guide/topics/connectivity/nfc/hce>.

19. Claim 11 of the '706 Patent recites “wherein the communication device is set up to generate communication-readiness signals to the reading device which in each case indicate to the reading device a communication readiness for one of the applications and comprise an identification number assigned to the corresponding communication-readiness application.” The Accused Products contain a communication device that is set up to generate communication-readiness signals to the reading device which in each case indicate to the reading device a communication readiness for one of the applications and comprise an identification number assigned to the corresponding communication-readiness application. For example, the communication device generates communication-readiness signals to an NFC reader which comprise of an Application ID (AID) that corresponds to an application:

## Service selection

When the user taps a device to an NFC reader, the Android system needs to know which HCE service the NFC reader wants to communicate with. The ISO/IEC 7816-4 specification defines a way to select applications, centered around an Application ID (AID). An AID consists of up to 16 bytes. If you are emulating cards for an existing NFC reader infrastructure, the AIDs that those readers look for are typically well-known and publicly registered (for example, the AIDs of payment networks such as Visa and MasterCard).

If you want to deploy new reader infrastructure for your own application, you must register your own AIDs. The registration procedure for AIDs is defined in the ISO/IEC 7816-5 specification. We recommend registering an AID as per 7816-5 if you are deploying a HCE application for Android, because it avoids collisions with other applications.

## AID conflict resolution

Multiple `HostApuService` components may be installed on a single device, and the same AID can be registered by more than one service. Android resolves AID conflicts differently depending on which category an AID belongs to. Each category may have a different conflict resolution policy.

For some categories, such as payment, the user might be able to select a default service in the Android settings UI. For other categories, the policy might be to always ask the user which service to invoke in case of conflict. For information about how to query the conflict resolution policy for a certain category, see `getSelectionModeForCategory()`.

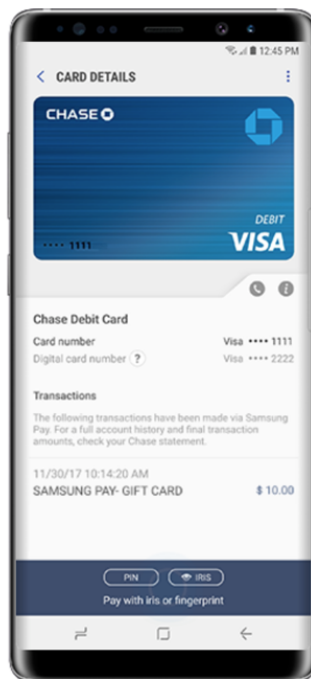
The following is an example of the corresponding `apduservice.xml` file registering two AIDs:

```
<offhost-apdu-service xmlns:android="http://schemas.android.com/apk/res/android"
    android:description="@string/servicedesc">
  <aid-group android:description="@string/subscription" android:category="other">
    <aid-filter android:name="F0010203040506" />
    <aid-filter android:name="F0394148148100" />
  </aid-group>
</offhost-apdu-service>
```

See <https://developer.android.com/guide/topics/connectivity/nfc/hce>.

20. Claim 11 of the '706 Patent recites “wherein the communication device is set up to store information in a nonvolatile memory of the data carrier about which of the at least two applications last communicated with a reading device.” Each of the Accused Products contains a communication device that is set up to store information in a nonvolatile memory of the data carrier about which of the at least two applications last communicated with a reading device. For example, the Accused Products provide information about the last application that communicated with a reading device:

Basic Functions

**View Recent Transactions**

**note:** Transactions made with Samsung Pay are available to view for one month from the time of purchase. A push notification with transaction details will be sent to your phone after each purchase.

See [https://publish.samsungsimulator.com/simulator/d9740827-40a4-4580-bf1e-3373b789f187/#!/topic/basic\\_functions/view\\_recent\\_transactions](https://publish.samsungsimulator.com/simulator/d9740827-40a4-4580-bf1e-3373b789f187/#!/topic/basic_functions/view_recent_transactions).

21. Samsung also knowingly and intentionally induces infringement of one or more claims of the '706 Patent in violation of 35 U.S.C. § 271(b). As of at least the filing and service of this complaint, Samsung has knowledge of the '706 Patent and the infringing nature of the Accused Products. Despite this knowledge of the '706 Patent, Samsung continues to actively encourage and instruct its customers and end users (for example, through user manuals and online instruction materials on its website, and other online publications cited above) to use the Accused Products in ways that directly infringe the '706 Patent, for example by utilizing the NFC functionality on the Accused Products and/or mobile payment applications, such as Samsung Pay or Google Pay, in an infringing manner. Samsung does so knowing and intending (or with willful

blindness to the fact) that its customers and end users will commit these infringing acts. Samsung also continues to make, use, offer for sale, sell, and/or import the Accused Products, despite its knowledge of the '706 Patent, thereby specifically intending for and inducing its customers to infringe the '706 Patent through the customers' normal and customary use of the Accused Products.

22. Samsung has also infringed, and continues to infringe, one or more claims of the '706 Patent by selling, offering for sale, or importing into the United States, the Accused Products, knowing that the Accused Products constitute a material part of the inventions claimed in the '706 Patent, are especially made or adapted to infringe the '706 Patent, and are not staple articles or commodities of commerce suitable for non-infringing use. Samsung has been, and currently is, contributorily infringing the '706 Patent in violation of 35 U.S.C. §§ 271(c) and (f).

23. By making, using, offering for sale, selling and/or importing into the United States the Accused Products, Samsung has injured Plaintiff and is liable for infringement of the '706 Patent pursuant to 35 U.S.C. § 271.

24. As a result of Samsung's infringement of the '706 Patent, Plaintiff is entitled to monetary damages (past, present, and future) in an amount adequate to compensate for Samsung's infringement, but in no event less than a reasonable royalty for the use made of the invention by Samsung, together with interest and costs as fixed by the Court.

## **COUNT II**

### **INFRINGEMENT OF U.S. PATENT NO. 8,816,827**

25. Plaintiff realleges and incorporates by reference the foregoing paragraphs as if fully set forth herein.

26. Samsung has been and is now directly infringing the '827 Patent, literally and/or under the doctrine of equivalents, in violation of 35 U.S.C. § 271(a), including by making, using, selling, and/or offering for sale in the United States or importing into the United States infringing products, including at least the Accused Products identified above. The Accused Products satisfy all of the claim limitations of one or more claims of the '827 Patent, including but not limited to claim 22.

27. Claim 22 of the '827 Patent recites a “contactlessly communicating portable data carrier.” To the extent the preamble is limiting, the Accused Products include portable data carriers that are capable of contactless communication through the use of Near Field Communication (NFC) technology. For example, Samsung advertises that the Accused Products support NFC:

Network & Connectivity	Galaxy S21 5G and S21+ 5G	Galaxy S21 Ultra 5G
	<b>5G</b> 5G Non-Standalone (NSA), Standalone (SA), Sub6 / mmWave	<b>5G</b> 5G Non-Standalone (NSA), Standalone (SA), Sub6 / mmWave
	<b>LTE</b> Enhanced 4x4 MIMO, Up to 7CA, LTE Cat.20 Up to 2.0Gbps Download / Up to 200Mbps Upload	<b>LTE</b> Enhanced 4x4 MIMO, Up to 7CA, LTE Cat.20 Up to 2.0Gbps Download / Up to 200Mbps Upload
	<b>Wi-Fi</b> Wi-Fi 802.11 a/b/g/n/ac/ax 2.4G+5GHz, HE80, MIMO, 1024-QAM Up to 1.2Gbps Download / Up to 1.2Gbps Upload	<b>Wi-Fi</b> Wi-Fi 802.11 a/b/g/n/ac/ax 2.4G+5GHz+6GHz, HE160, MIMO, 1024-QAM Up to 2.4Gbps Download / Up to 2.4Gbps Upload
	<b>Bluetooth</b> Bluetooth® v 5.0, USB type-C, NFC, Location (GPS, Galileo, Glonass, BeiDou)	<b>Bluetooth</b> Bluetooth® v 5.2, USB type-C, NFC, Location (GPS, Galileo, Glonass, BeiDou)

**Samsung Pay**

- Credit & debit cards: supports MST and/or NFC
- Membership cards
- Gift cards
- Transit cards

See <https://www.samsung.com/global/galaxy/galaxy-s21-ultra-5g/specs/>.

28. Claim 22 of the '827 Patent recites that the portable data carrier comprises “at least a first and second application stored thereon.” The Accused Products are configured to store at least two applications. For example, the Accused Products are configured to store at least two applications that utilize NFC:

#### Service selection

When the user taps a device to an NFC reader, the Android system needs to know which HCE service the NFC reader wants to communicate with. The ISO/IEC 7816-4 specification defines a way to select applications, centered around an Application ID (AID). An AID consists of up to 16 bytes. If you are emulating cards for an existing NFC reader infrastructure, the AIDs that those readers look for are typically well-known and publicly registered (for example, the AIDs of payment networks such as Visa and MasterCard).

If you want to deploy new reader infrastructure for your own application, you must register your own AIDs. The registration procedure for AIDs is defined in the ISO/IEC 7816-5 specification. We recommend registering an AID as per 7816-5 if you are deploying a HCE application for Android, because it avoids collisions with other applications.

#### AID conflict resolution

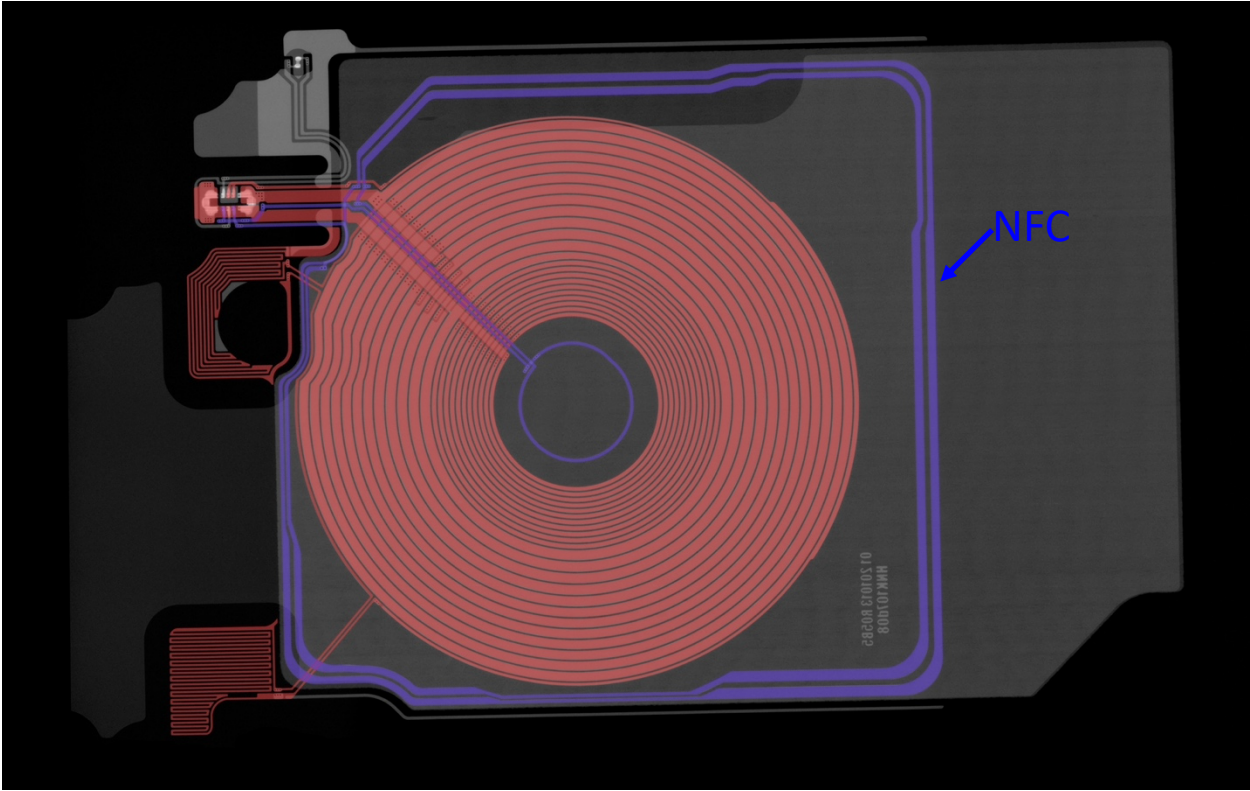
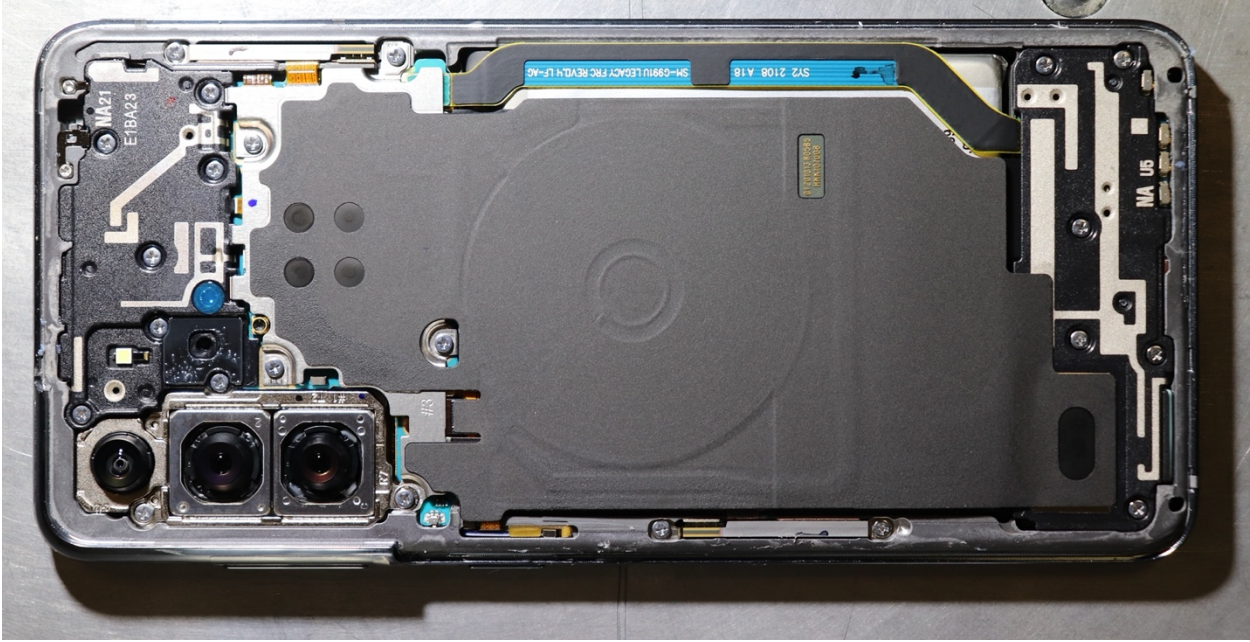
Multiple `HostApuService` components may be installed on a single device, and the same AID can be registered by more than one service. Android resolves AID conflicts differently depending on which category an AID belongs to. Each category may have a different conflict resolution policy.

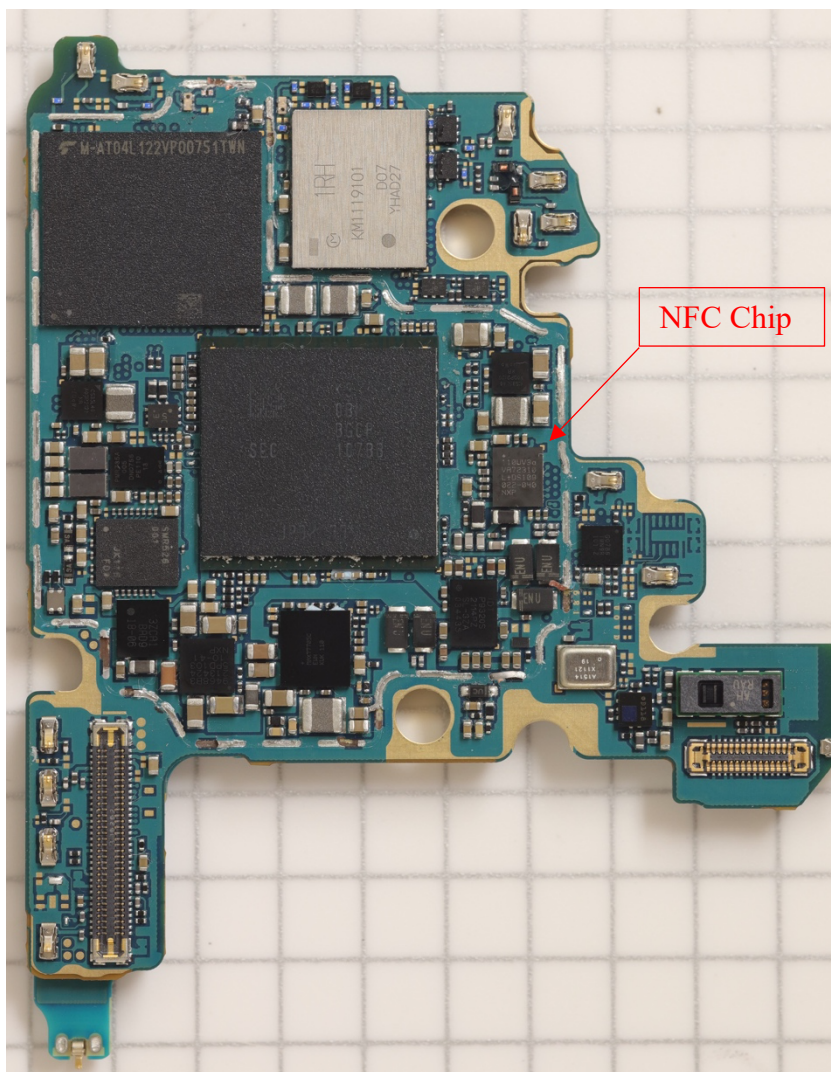
For some categories, such as payment, the user might be able to select a default service in the Android settings UI. For other categories, the policy might be to always ask the user which service to invoke in case of conflict. For information about how to query the conflict resolution policy for a certain category, see `getSelectionModeForCategory()`.

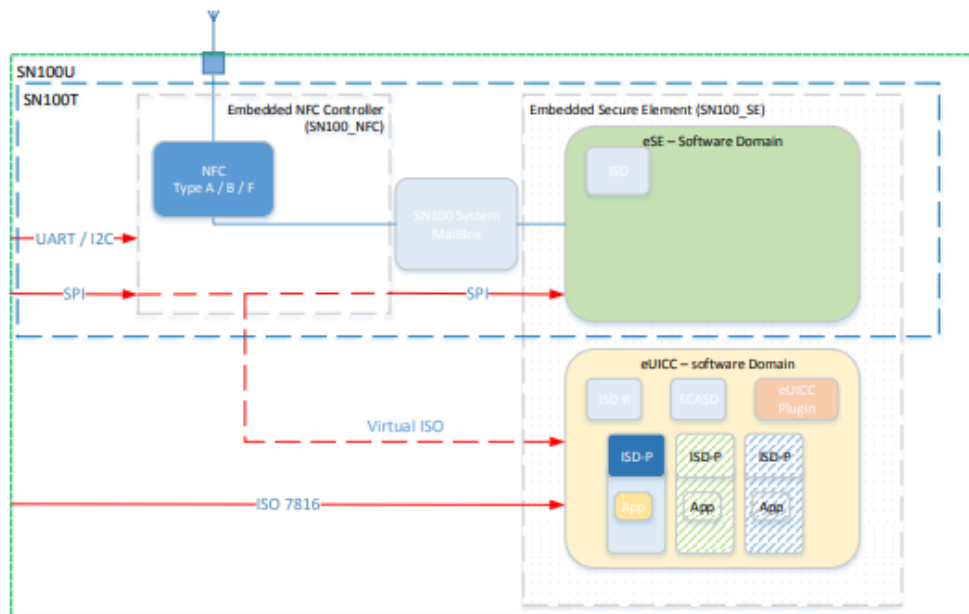
See <https://developer.android.com/guide/topics/connectivity/nfc/hce>.

29. Claim 22 of the '827 Patent recites “a communication device for controlling communication between a reading device and the at least first and second applications.” The Accused Products contain a communication device configured to control communication between a reading device and the at least first and second applications. For example, the Accused Products utilize an NFC antenna, NFC chip, and related hardware and software to control communication with a reading device and at least a first and second application, as shown in the exemplary Samsung S21:



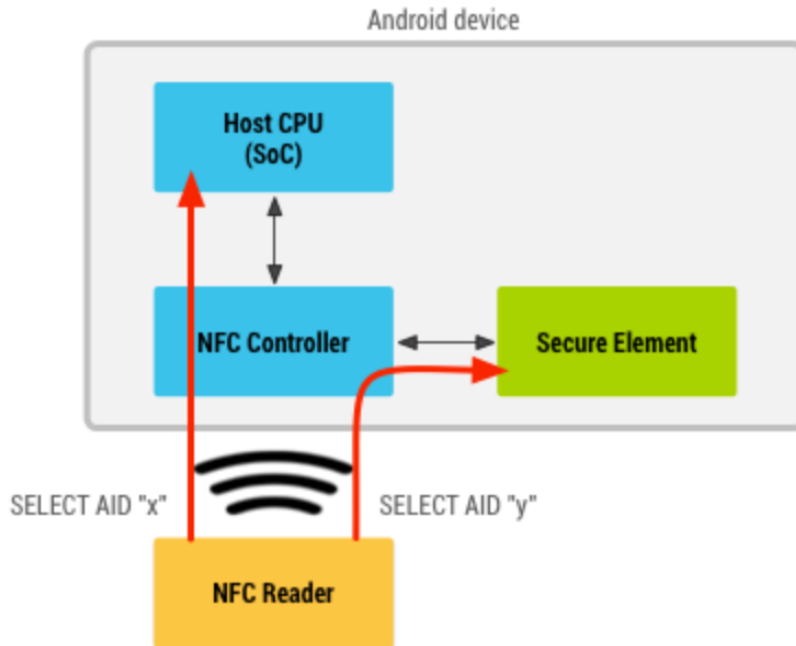






**Fig. 1.2: SN100x Product Configurations**

See [https://www.commoncriteriaportal.org/files/epfiles/SecurityTarget-Lite\\_SN100T\\_v1.1\\_20190418.pdf](https://www.commoncriteriaportal.org/files/epfiles/SecurityTarget-Lite_SN100T_v1.1_20190418.pdf); see also [https://www.emvco.com/wp-content/uploads/approved\\_products/uploaded/loa/MTA\\_LOA\\_SAE\\_L\\_02859\\_24Nov20\\_SHORT.pdf](https://www.emvco.com/wp-content/uploads/approved_products/uploaded/loa/MTA_LOA_SAE_L_02859_24Nov20_SHORT.pdf).



See <https://developer.android.com/guide/topics/connectivity/nfc/hce>.

30. Claim 22 recites “wherein the communication device is configured to generate a first communication-readiness signal to the reading device which indicates to the reading device a communication readiness for the first application and a second communication-readiness signal to the reading device which indicates the reading device a communication readiness for the second application and comprise an identification number assigned to the corresponding communication-readiness application.” The Accused Products contain a communication device that is configured to generate a first communication-readiness signal to the reading device which indicates to the reading device a communication readiness for the first application and a second communication-readiness signal to the reading device which indicates the reading device a communication readiness for the second application and comprise an identification number assigned to the corresponding communication-readiness application. For example, the communication device generates communication-readiness signals to an NFC reader which comprise of an Application ID (AID) that corresponds to an application:

## Service selection

When the user taps a device to an NFC reader, the Android system needs to know which HCE service the NFC reader wants to communicate with. The ISO/IEC 7816-4 specification defines a way to select applications, centered around an Application ID (AID). An AID consists of up to 16 bytes. If you are emulating cards for an existing NFC reader infrastructure, the AIDs that those readers look for are typically well-known and publicly registered (for example, the AIDs of payment networks such as Visa and MasterCard).

If you want to deploy new reader infrastructure for your own application, you must register your own AIDs. The registration procedure for AIDs is defined in the ISO/IEC 7816-5 specification. We recommend registering an AID as per 7816-5 if you are deploying a HCE application for Android, because it avoids collisions with other applications.

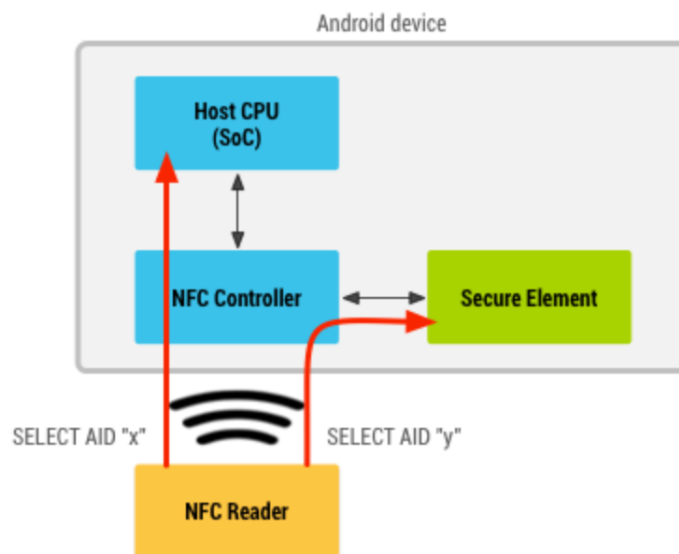
## AID conflict resolution

Multiple `HostApduService` components may be installed on a single device, and the same AID can be registered by more than one service. Android resolves AID conflicts differently depending on which category an AID belongs to. Each category may have a different conflict resolution policy.

For some categories, such as payment, the user might be able to select a default service in the Android settings UI. For other categories, the policy might be to always ask the user which service to invoke in case of conflict. For information about how to query the conflict resolution policy for a certain category, see `getSelectionModeForCategory()`.

The following is an example of the corresponding `apdu-service.xml` file registering two AIDs:

```
<offhost-apdu-service xmlns:android="http://schemas.android.com/apk/res/android"
    android:description="@string/servicedesc">
  <aid-group android:description="@string/subscription" android:category="other">
    <aid-filter android:name="F0010203040506" />
    <aid-filter android:name="F0394148148100" />
  </aid-group>
</offhost-apdu-service>
```



See <https://developer.android.com/guide/topics/connectivity/nfc/hce>.

31. Claim 22 of the '827 Patent recites “wherein the first communication-readiness signal is generated for a first group of applications comprising a first plurality of applications including the first application, and the first identification number is assigned to every application in the first group, and the second communication-readiness signal is generated for a second group of applications comprising a second plurality of applications including the second application, and the second identification number is assigned to every application in the second group, the first communication-readiness signal indicating to the reading device the communication readiness of every application of the first group, and the second communication-readiness signal indicating to the reading device the communication readiness of every application of the second group.” The Accused Products generate the first communication-readiness signal for a first group of applications comprising a first plurality of applications including the first application, and the first identification number is assigned to every application in the first group, and the second communication-readiness signal is generated for a second group of applications comprising a second plurality of applications including the second application, and the second identification number is assigned to every application in the second group, the first communication-readiness signal indicating to the reading device the communication readiness of every application of the first group, and the second communication-readiness signal indicating to the reading device the communication readiness of every application of the second group. For example, the Accused Products are configured to generate Application IDs (AID) for at least a first and second group of applications:

## AID groups

In some cases, an HCE service may need to register multiple AIDs and be set as the default handler for all of the AIDs in order to implement a certain application. Some AIDs in the group going to another service isn't supported.

A list of AIDs that are kept together is called an AID group. For all AIDs in an AID group, Android guarantees one of the following:

- All AIDs in the group are routed to this HCE service.
- No AIDs in the group are routed to this HCE service (for example, because the user preferred another service which requested one or more AIDs in your group as well).

In other words, there is no in-between state, where some AIDs in the group can be routed to one HCE service, and some to another.

## AID groups and categories

You can associate each AID group with a category. This allows Android to group HCE services together by category, and that in turn allows the user to set defaults at the category level instead of the AID level. Avoid mentioning AIDs in any user-facing parts of your application, because they don't mean anything to the average user.

Android 4.4 and higher supports two categories:

- `CATEGORY_PAYMENT` (covering industry-standard payment apps)
- `CATEGORY_OTHER` (for all other HCE apps)

See <https://developer.android.com/guide/topics/connectivity/nfc/hce#aid-groups>.

32. Samsung also knowingly and intentionally induces infringement of one or more claims of the '827 Patent in violation of 35 U.S.C. § 271(b). As of at least the filing and service of this complaint, Samsung has knowledge of the '827 Patent and the infringing nature of the Accused Products. Despite this knowledge of the '827 Patent, Samsung continues to actively encourage and instruct its customers and end users (for example, through user manuals and online instruction materials on its website, and other online publications cited above) to use the Accused Products in ways that directly infringe the '827 Patent, for example by utilizing the NFC functionality on the Accused Products and/or mobile payment applications, such as Samsung Pay or Google Pay, in an infringing manner. Samsung does so knowing and intending (or with willful blindness to the fact) that its customers and end users will commit these infringing acts. Samsung also continues to make, use, offer for sale, sell, and/or import the Accused Products, despite its

knowledge of the '827 Patent, thereby specifically intending for and inducing its customers to infringe the '827 Patent through the customers' normal and customary use of the Accused Products.

33. Samsung has also infringed, and continues to infringe, one or more claims of the '827 Patent by selling, offering for sale, or importing into the United States, the Accused Products, knowing that the Accused Products constitute a material part of the inventions claimed in the '827 Patent, are especially made or adapted to infringe the '827 Patent, and are not staple articles or commodities of commerce suitable for non-infringing use. Samsung has been, and currently is, contributorily infringing the '827 Patent in violation of 35 U.S.C. §§ 271(c) and (f).

34. By making, using, offering for sale, selling and/or importing into the United States the Accused Products, Samsung has injured Plaintiff and is liable for infringement of the '827 Patent pursuant to 35 U.S.C. § 271.

35. As a result of Samsung's infringement of the '827 Patent, Plaintiff is entitled to monetary damages (past, present, and future) in an amount adequate to compensate for Samsung's infringement, but in no event less than a reasonable royalty for the use made of the invention by Samsung, together with interest and costs as fixed by the Court.

### **COUNT III**

#### **INFRINGEMENT OF U.S. PATENT NO. 8,205,249**

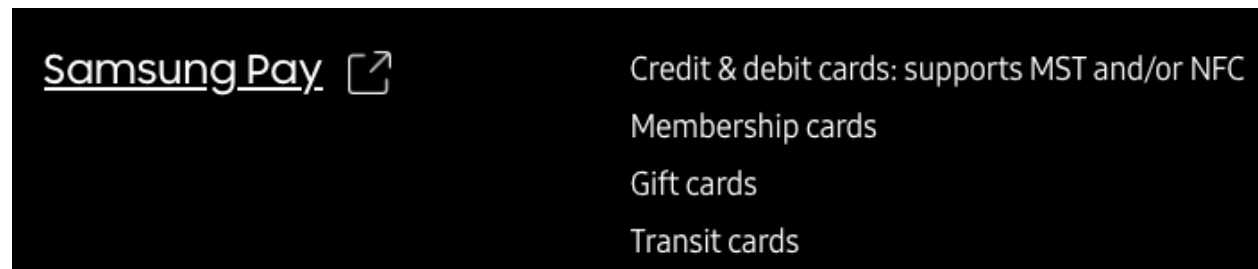
36. Plaintiff realleges and incorporates by reference the foregoing paragraphs as if fully set forth herein.

37. Samsung has been and is now directly infringing the '249 Patent, literally and/or under the doctrine of equivalents, in violation of 35 U.S.C. § 271(a), including by making, using, selling, and/or offering for sale in the United States or importing into the United States infringing



products, including at least the Accused Products identified above. The Accused Products satisfy all of the claim limitations of one or more claims of the '249 Patent, including but not limited to claim 10.

38. Claim 10 recites a “portable data carrier for performing a security-operation within a secure electronic transaction.” To the extent the preamble is limiting, the Accused Products include a portable data carrier for performing a security-operation within a secure electronic transaction. For example, the Accused Products support mobile payment applications, such as Samsung Pay and Google Pay, which enable users to perform a security-operation within a secure electronic transaction:



See <https://www.samsung.com/global/galaxy/galaxy-s21-ultra-5g/specs/>.

# What is Samsung Pay?

Samsung Pay simplifies how you pay, safely. Accepted at more locations than most other methods of mobile payment thanks to MST and NFC support, you only need your Galaxy phone to swipe up from the home button and authorize the payment through its highly secure fingerprint identification system. Then place the phone against the card reader and you're set, all in a matter of seconds.

Samsung Pay is so safe that it secures your payment information with several added layers of security, keeping it locked and hidden from any third parties. For further peace of mind, its built-in Samsung Knox technology offers nonstop monitoring. And should you ever lose your phone, you can simply deactivate remotely should it fall into the wrong hands.

Discover more about Galaxy for yourself.

See <https://www.samsung.com/global/galaxy/what-is/samsung-pay/>.

39. Claim 10 of the '249 Patent recites that the portable data carrier is “arranged to perform different quality user authentication methods.” To the extent the preamble is limiting, the Accused Products include a portable data carrier that is arranged to perform different quality user authentication methods. For example, the Accused Products support mobile payment applications, such as Samsung Pay and Google Pay, which utilize different quality user authentication methods:

## Is Samsung Pay secure?

Samsung Pay transactions are authorized with a PIN, fingerprint, or iris scan. After repeated failure to authenticate, Samsung Pay will erase all card data. Also, each transaction uses a random token instead of the actual card number, which means no real information from the original card or account is shared by Samsung Pay. Finally, using Samsung Knox technology, the phone is constantly monitored for signs of malicious attacks or vulnerabilities. Even if the phone is ever compromised, card information is still safely encrypted within a separate, secure data vault. If your device is ever lost or stolen, you can remotely [lock or erase Samsung Pay data](#) using Find My Mobile.

See <https://www.samsung.com/us/support/answer/ANS00080583/>.

40. Claim 10 recites “wherein the difference in quality of said user authentication methods varies between an inherently relatively lower quality and an inherently relatively higher

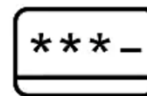
quality from a security perspective.” To the extent the preamble is limiting, the Accused Products include a data carrier arranged to perform different quality user authentication methods, wherein the difference in quality of said user authentication methods varies between an inherently relatively lower quality and an inherently relatively higher quality from a security perspective. For example, the Accused Products support mobile payment applications, such as Samsung Pay and Google Pay, which utilize different authentication methods that vary in quality from a security perspective:



#### User authentication

Every transaction is authenticated by your fingerprint, PIN or facial recognition. If your phone is lost or stolen, you can remotely lock or erase your Samsung Pay account with Find My Mobile.\*

\*It is necessary to activate Find My Mobile for this feature in advance



#### Data security

Tokenization creates a unique randomized set of numbers to be used at each new transaction, so your real card number is never used from your phone.



## Tap. Pay. Go.

#### Tap & Pay:

Now use Samsung Pay to ride New York City's MTA system and Portland's TriMet system. No need to open the app or even unlock your device to make a payment — just tap your phone on the mobile pay location on the turnstile or ticket validator and go. Simply set one of your payment cards in Samsung Pay as your default transit payment method and you're on your way.

To pay at a transit operator that does not support Tap & Pay, use Samsung Pay as usual — just swipe up on your device to select your payment card, authenticate yourself with your fingerprint or PIN and then tap your device on top of the ticket validator.

Note: Samsung Pay currently supports Visa, MasterCard and Amex cards for this Transit feature.

[NEW YORK \(MTA\)](#)   [PORTLAND \(TRIMET\)](#)   [CHICAGO \(CTA\)](#)

See <https://www.samsung.com/us/samsung-pay/>.

2.5 Membership Programs. Samsung Pay provides access to certain third party loyalty or membership Cards and similar programs (“Membership Program(s)”). You agree to comply with any additional terms and conditions established by the Membership Program provider. Membership Cards may be accessed or used in Samsung Pay with or without biometric authentication or PIN verification. Membership Cards added to Your device may be stored by Samsung allowing for portability to other Samsung devices. Samsung is not liable for any errors or omissions contained within any Membership Program. You agree to look solely to the Membership Program provider to resolve any questions or disputes relating to a Membership Program.

See [https://image-us.samsung.com/SamsungUS/home/samsung-pay/01202021/pdf/SamsungPay-Terms-of-Use\\_RewardsUpdate.pdf](https://image-us.samsung.com/SamsungUS/home/samsung-pay/01202021/pdf/SamsungPay-Terms-of-Use_RewardsUpdate.pdf).

Settings  
**Turn Fast Checkout On or Off**



**note:** Fast Checkout allows merchant app users to bypass authentication during checkout, using payment information from the last transaction.

See [https://publish.samsungsimulator.com/simulator/d9740827-40a4-4580-bf1e-3373b789f187/#!/top5/settings/turn\\_fast\\_checkout\\_on\\_or\\_off](https://publish.samsungsimulator.com/simulator/d9740827-40a4-4580-bf1e-3373b789f187/#!/top5/settings/turn_fast_checkout_on_or_off).

41. Claim 10 of the '249 Patent recites that “the portable data carrier is arranged to perform a user authentication using one of said implemented user authentication methods.” The

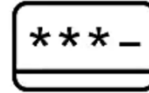
Accused Products include a portable data carrier arranged to perform a user authentication using one of said implemented user authentication methods. For example, the Accused Products support mobile payment applications, such as Samsung Pay and Google Pay, which utilize different user authentication methods:



### User authentication

Every transaction is authenticated by your fingerprint, PIN or facial recognition. If your phone is lost or stolen, you can remotely lock or erase your Samsung Pay account with Find My Mobile.\*

\*It is necessary to activate Find My Mobile for this feature in advance



### Data security

Tokenization creates a unique randomized set of numbers to be used at each new transaction, so your real card number is never used from your phone.



## Tap. Pay. Go.

### Tap & Pay:

Now use Samsung Pay to ride New York City's MTA system and Portland's TriMet system. No need to open the app or even unlock your device to make a payment — just tap your phone on the mobile pay location on the turnstile or ticket validator and go. Simply set one of your payment cards in Samsung Pay as your default transit payment method and you're on your way.

To pay at a transit operator that does not support Tap & Pay, use Samsung Pay as usual — just swipe up on your device to select your payment card, authenticate yourself with your fingerprint or PIN and then tap your device on top of the ticket validator.

Note: Samsung Pay currently supports Visa, MasterCard and Amex cards for this Transit feature.

NEW YORK (MTA)    PORTLAND (TRIMET)    CHICAGO (CTA)

See <https://www.samsung.com/us/samsung-pay/>.

2.5 Membership Programs. Samsung Pay provides access to certain third party loyalty or membership Cards and similar programs (“Membership Program(s)”). You agree to comply with any additional terms and conditions established by the Membership Program provider. Membership Cards may be accessed or used in Samsung Pay with or without biometric authentication or PIN verification. Membership Cards added to Your device may be stored by Samsung allowing for portability to other Samsung devices. Samsung is not liable for any errors or omissions contained within any Membership Program. You agree to look solely to the Membership Program provider to resolve any questions or disputes relating to a Membership Program.

See [https://image-us.samsung.com/SamsungUS/home/samsung-pay/01202021/pdf/SamsungPay-Terms-of-Use\\_RewardsUpdate.pdf](https://image-us.samsung.com/SamsungUS/home/samsung-pay/01202021/pdf/SamsungPay-Terms-of-Use_RewardsUpdate.pdf).

Settings  
**Turn Fast Checkout On or Off**

---



**note:** Fast Checkout allows merchant app users to bypass authentication during checkout, using payment information from the last transaction.

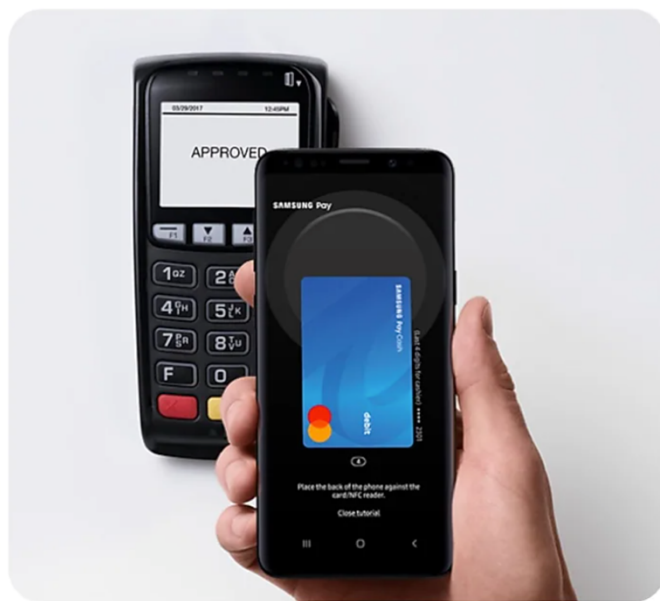
See [https://publish.samsungsimulator.com/simulator/d9740827-40a4-4580-bf1e-3373b789f187/#!top5/settings/turn\\_fast\\_checkout\\_on\\_or\\_off](https://publish.samsungsimulator.com/simulator/d9740827-40a4-4580-bf1e-3373b789f187/#!top5/settings/turn_fast_checkout_on_or_off).

42. Claim 10 of the '249 Patent recites that “the portable data carrier is arranged to confirm the authentication to a terminal.” The Accused Products include a portable data carrier arranged to confirm the authentication to a terminal. For example, the Accused Products support

mobile payment applications, such as Samsung Pay and Google Pay, and confirm the authentication to a terminal:

## Accepted at millions of places.

Samsung Pay works in-store, in-app and online. Load your cards onto your devices and check out with a tap.<sup>1</sup>



## Pay where you want.

The latest Samsung devices work at all your favorite places, making Samsung Pay the most accepted mobile payment.

See <https://www.samsung.com/us/samsung-pay/>.

## Basic Functions

# Make a Payment

---



**note:** Samsung Pay lets you make payments from your phone. You can make payments with a Samsung-approved case on your phone. Third-party cases may cause problems with payment. If you experience an issue, remove the case and try again.

## Basic Functions

# Make a Payment

---



**note:** Samsung Pay lets you make payments from your phone. You can make payments with a Samsung-approved case on your phone. Third-party cases may cause problems with payment. If you experience an issue, remove the case and try again.



## Basic Functions

**Make a Payment**

**note:** Samsung Pay lets you make payments from your phone. You can make payments with a Samsung-approved case on your phone. Third-party cases may cause problems with payment. If you experience an issue, remove the case and try again.

See [https://publish.samsungsimulator.com/simulator/d9740827-40a4-4580-bf1e-3373b789f187/#!topic/basic\\_functions/make\\_a\\_payment](https://publish.samsungsimulator.com/simulator/d9740827-40a4-4580-bf1e-3373b789f187/#!topic/basic_functions/make_a_payment).

With the [Samsung Pay system](#), the card network returns card data that's been tokenized using a secure channel to the device, and hardware-based keys within the device encrypt and authenticate its data. Only encrypted data is returned to the Samsung Pay app to avoid security and privacy risks. The security and integrity of the tokenized data is protected because it can only be accessed in the Trusted Execution Environment (TEE) of the device. When the tokenized card details are sent to the TEE, an authentication code is generated for that particular transaction. With Samsung Pay, tokenization is available for securing both near field communication and magnetic stripe payments.

To protect a user's card data and payment information, a secure communication channel is created between user devices and card network servers using public key cryptography. Once a transaction is initiated, a cryptogram (a unique authentication code) is sent to the payment terminal. This authentication code verifies that the mobile device with which it's associated is the one being used to make the transaction. Both the token and the authentication code must be verified by the card network for the transaction to proceed. This verifies that the user is the correct person to make a transaction.

See <https://insights.samsung.com/2016/02/08/advancing-mobile-payment-security-with-tokenization/>.

43. Claim 10 of the '249 Patent recites “wherein the data carrier is arranged to create quality information about said user authentication method used and to attach such quality information to the result of the security establishing operation.” The Accused Products include a portable data carrier that is arranged to create quality information about the user authentication method used and to attach such quality information to the result of the security establishing operation. For example, on information and belief, the Accused Products include a data carrier that creates quality information about the type of authentication method used by a user and attach that information to the result of the security establishing operation in an electronic transaction.

44. Samsung also knowingly and intentionally induces infringement of one or more claims of the '249 Patent in violation of 35 U.S.C. § 271(b). As of at least the filing and service of this complaint, Samsung has knowledge of the '249 Patent and the infringing nature of the Accused Products. Despite this knowledge of the '249 Patent, Samsung continues to actively encourage and instruct its customers and end users (for example, through user manuals and online instruction materials on its website, and other online publications cited above) to use the Accused Products in ways that directly infringe the '249 Patent, for example by utilizing the NFC functionality on the Accused Products and/or mobile payment applications, such as Samsung Pay or Google Pay, in an infringing manner. Samsung does so knowing and intending (or with willful blindness to the fact) that its customers and end users will commit these infringing acts. Samsung also continues to make, use, offer for sale, sell, and/or import the Accused Products, despite its knowledge of the '249 Patent, thereby specifically intending for and inducing its customers to infringe the '249 Patent through the customers' normal and customary use of the Accused Products.

45. Samsung has also infringed, and continues to infringe, one or more claims of the '249 Patent by selling, offering for sale, or importing into the United States, the Accused Products, knowing that the Accused Products constitute a material part of the inventions claimed in the '249 Patent, are especially made or adapted to infringe the '249 Patent, and are not staple articles or commodities of commerce suitable for non-infringing use. Samsung has been, and currently is, contributorily infringing the '249 Patent in violation of 35 U.S.C. §§ 271(c) and (f).

46. By making, using, offering for sale, selling and/or importing into the United States the Accused Products, Samsung has injured Plaintiff and is liable for infringement of the '249 Patent pursuant to 35 U.S.C. § 271.

47. As a result of Samsung's infringement of the '249 Patent, Plaintiff is entitled to monetary damages (past, present, and future) in an amount adequate to compensate for Samsung's infringement, but in no event less than a reasonable royalty for the use made of the invention by Samsung, together with interest and costs as fixed by the Court.

#### **COUNT IV**

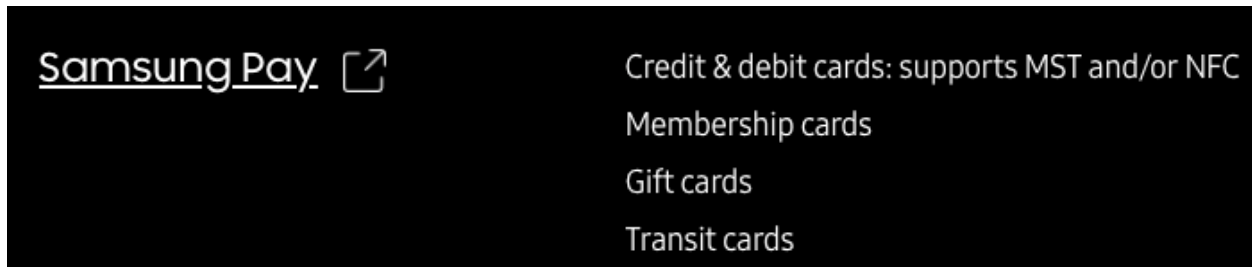
#### **INFRINGEMENT OF U.S. PATENT NO. 8,174,360**

48. Plaintiff realleges and incorporates by reference the foregoing paragraphs as if fully set forth herein.

49. Samsung has been and is now directly infringing the '360 Patent, literally and/or under the doctrine of equivalents, in violation of 35 U.S.C. § 271, including by making, using, selling, and/or offering for sale in the United States or importing into the United States infringing products, including at least the Accused Products identified above. The Accused Products satisfy all of the claim limitations of one or more claims of the '360 Patent, including but not limited to claim 1.

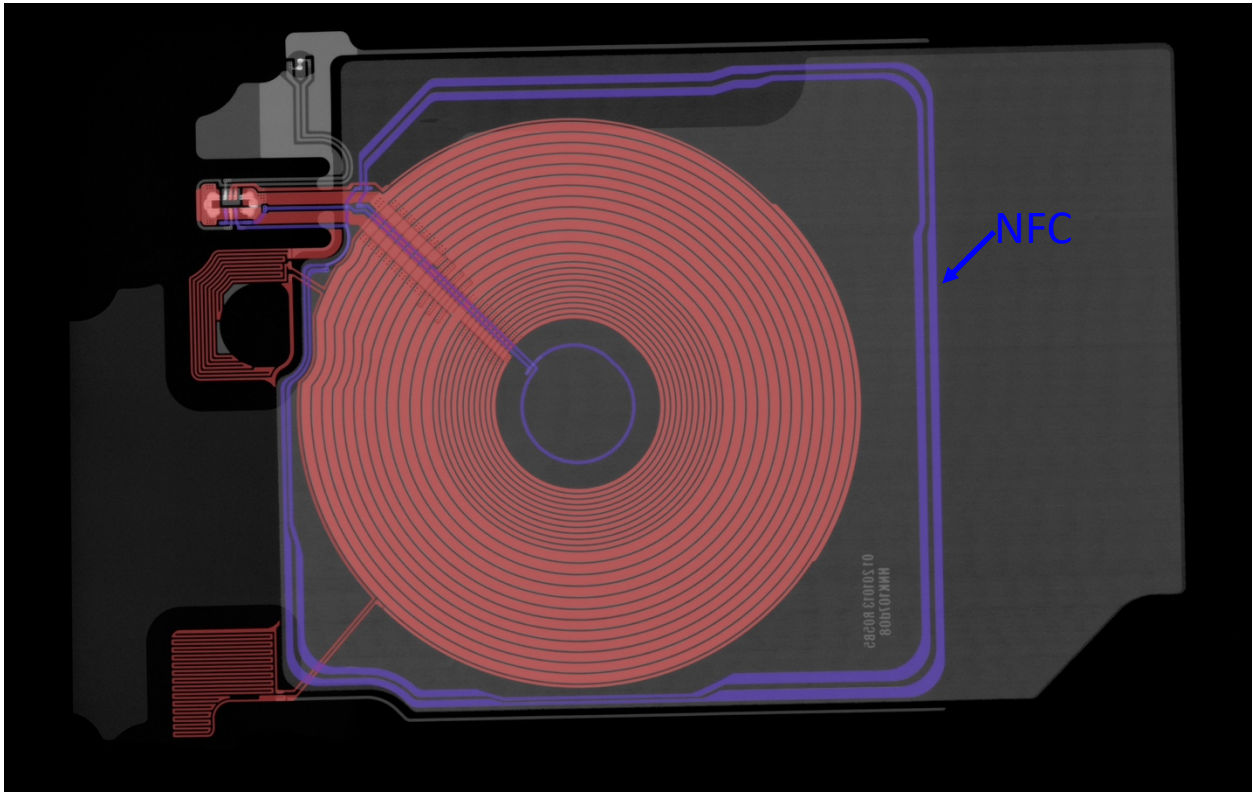
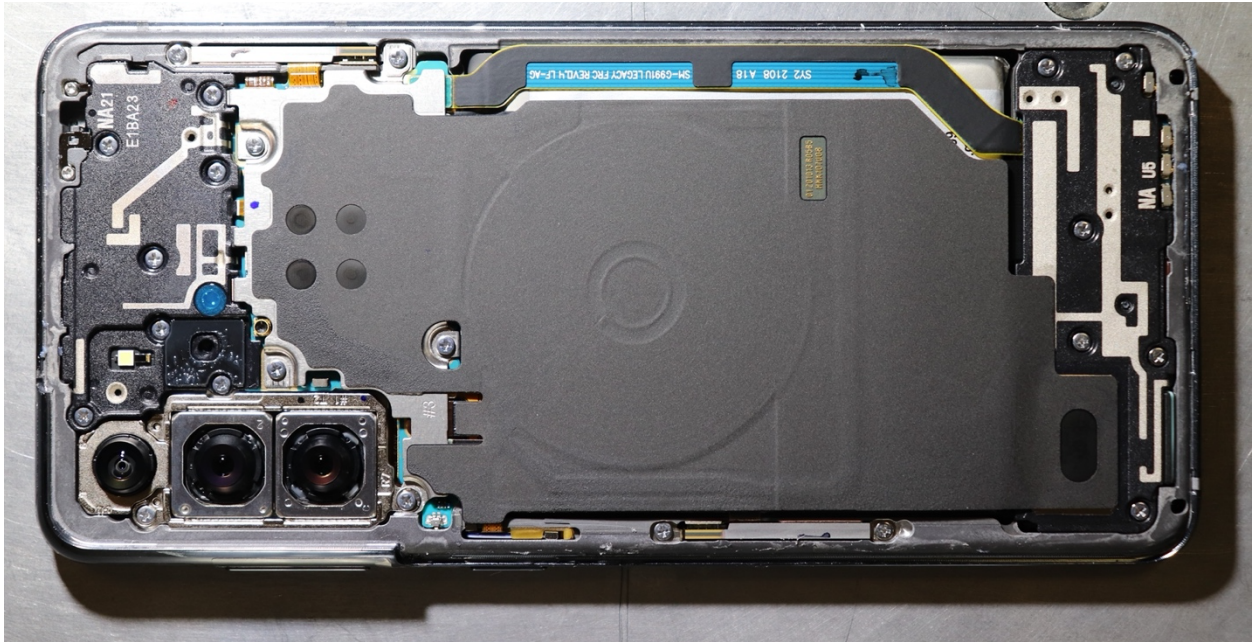
50. Claim 1 of the '360 Patent recites a “communication apparatus for setting up a data connection between intelligent devices.” To the extent the preamble is limiting, the Accused Products include a communication apparatus for setting up a data connection between intelligent devices. For example, Samsung advertises that the Accused Products support NFC:

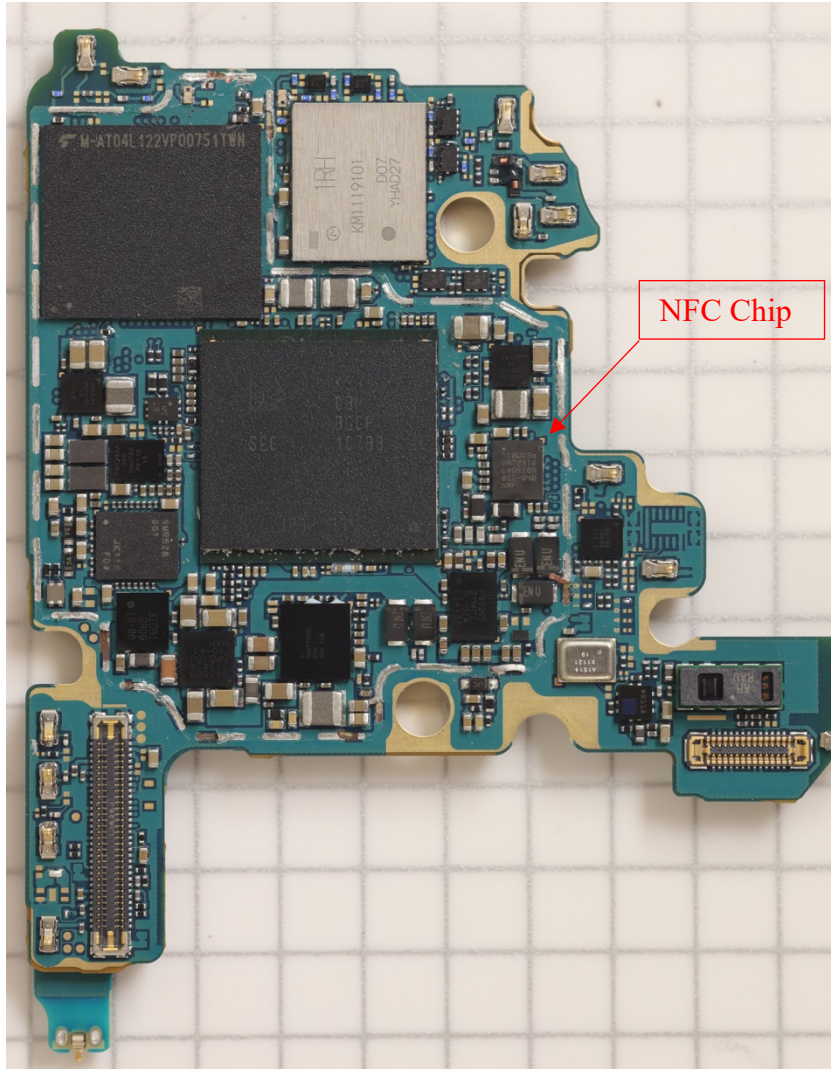
Network & Connectivity	Galaxy S21 5G and S21+ 5G	Galaxy S21 Ultra 5G
	<b>5G</b> 5G Non-Standalone (NSA), Standalone (SA), Sub6 / mmWave	<b>5G</b> 5G Non-Standalone (NSA), Standalone (SA), Sub6 / mmWave
	<b>LTE</b> Enhanced 4x4 MIMO, Up to 7CA, LTE Cat.20 Up to 2.0Gbps Download / Up to 200Mbps Upload	<b>LTE</b> Enhanced 4x4 MIMO, Up to 7CA, LTE Cat.20 Up to 2.0Gbps Download / Up to 200Mbps Upload
	<b>Wi-Fi</b> Wi-Fi 802.11 a/b/g/n/ac/ax 2.4G+5GHz, HE80, MIMO, 1024-QAM Up to 1.2Gbps Download / Up to 1.2Gbps Upload	<b>Wi-Fi</b> Wi-Fi 802.11 a/b/g/n/ac/ax 2.4G+5GHz+6GHz, HE160, MIMO, 1024-QAM Up to 2.4Gbps Download / Up to 2.4Gbps Upload
	<b>Bluetooth</b> Bluetooth® v 5.0, USB type-C, NFC, Location (GPS, Galileo, Glonass, BeiDou)	<b>Bluetooth</b> Bluetooth® v 5.2, USB type-C, NFC, Location (GPS, Galileo, Glonass, BeiDou)

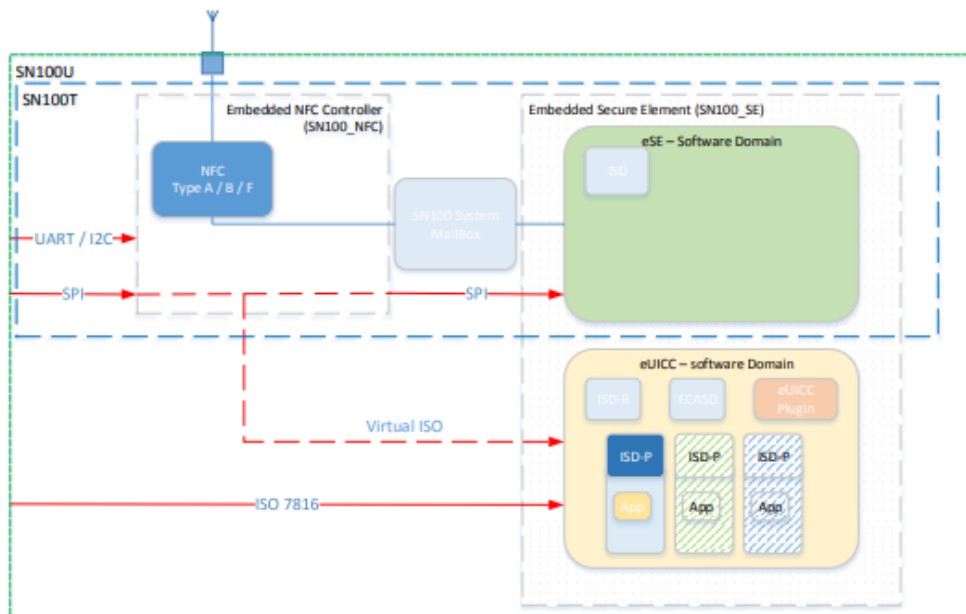


See <https://www.samsung.com/global/galaxy/galaxy-s21-ultra-5g/specs/>.

51. Claim 1 of the '360 Patent recites an “apparatus” comprising “a transmission oscillator for carrying out a contactless data exchange, said oscillator including a coil.” The Accused Products include a transmission oscillator for carrying out a contactless data exchange, said oscillator including a coil. For example, the Accused Products include an NFC antenna, NFC chip, and related hardware and software, as shown in the exemplary Samsung S21:



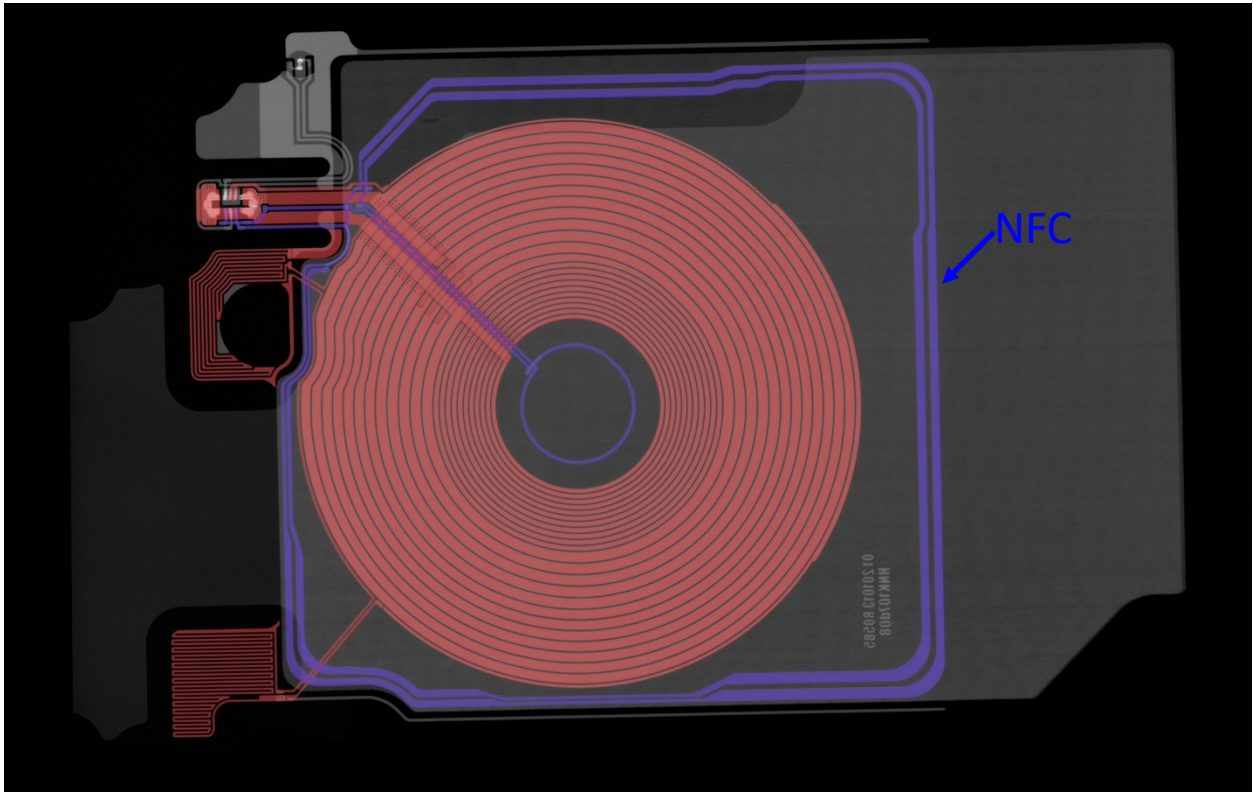
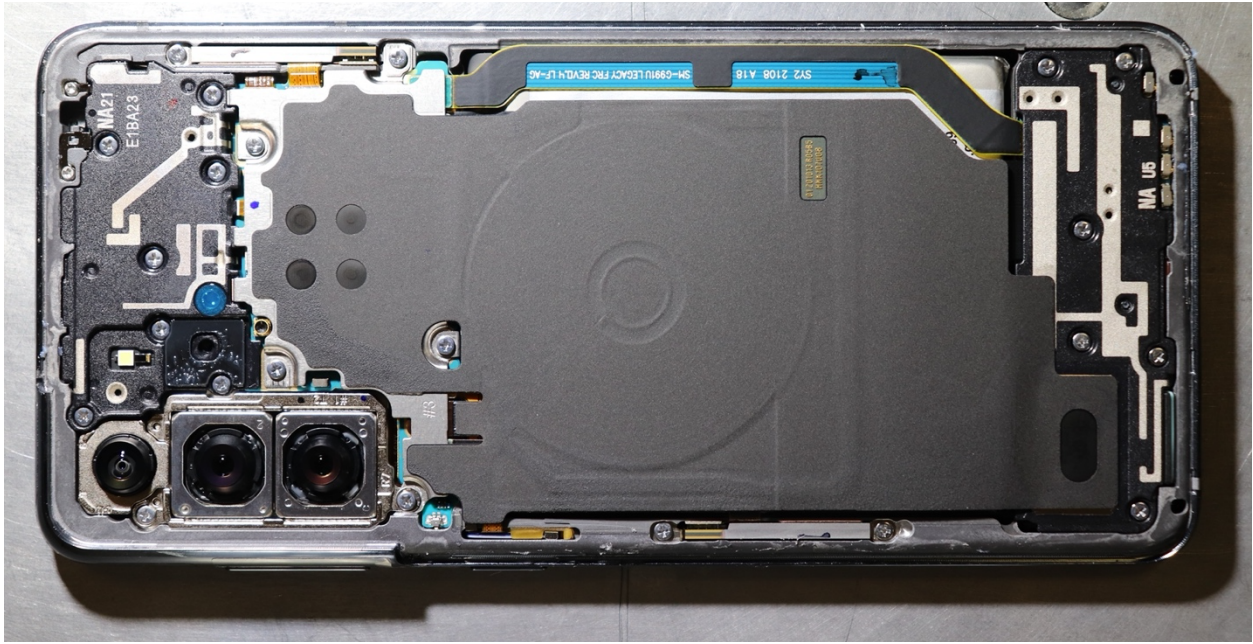




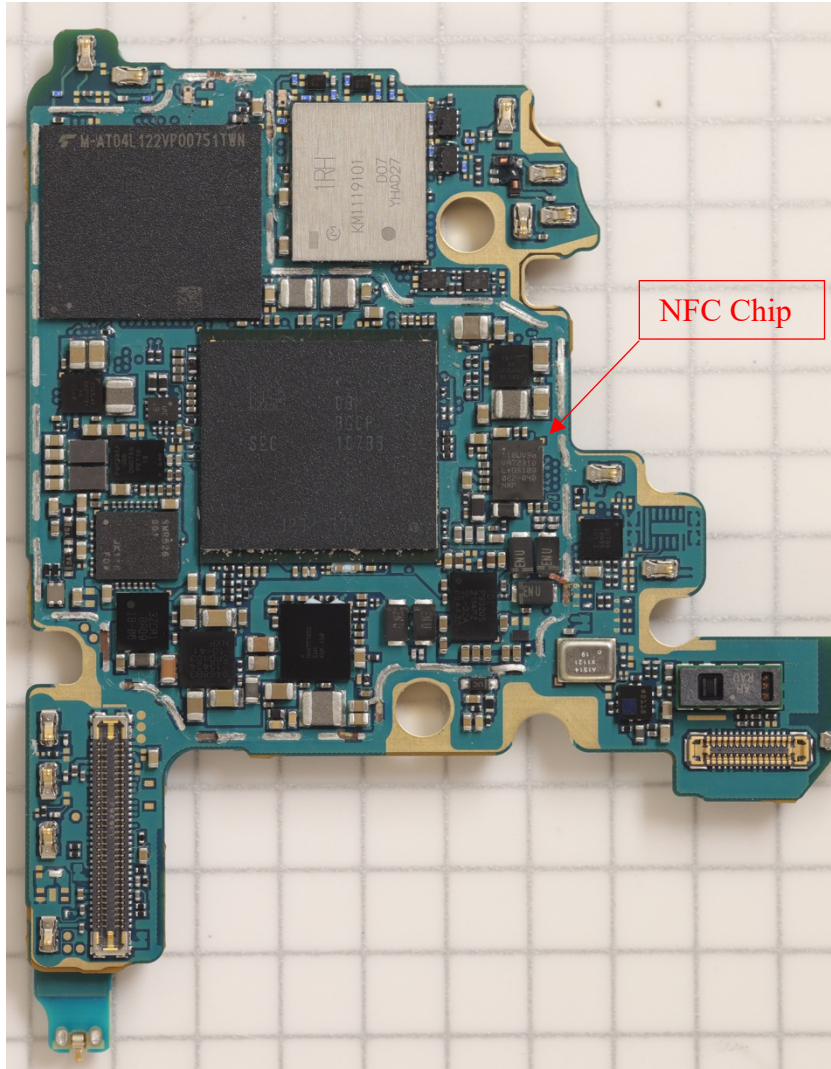
**Fig. 1.2: SN100x Product Configurations**

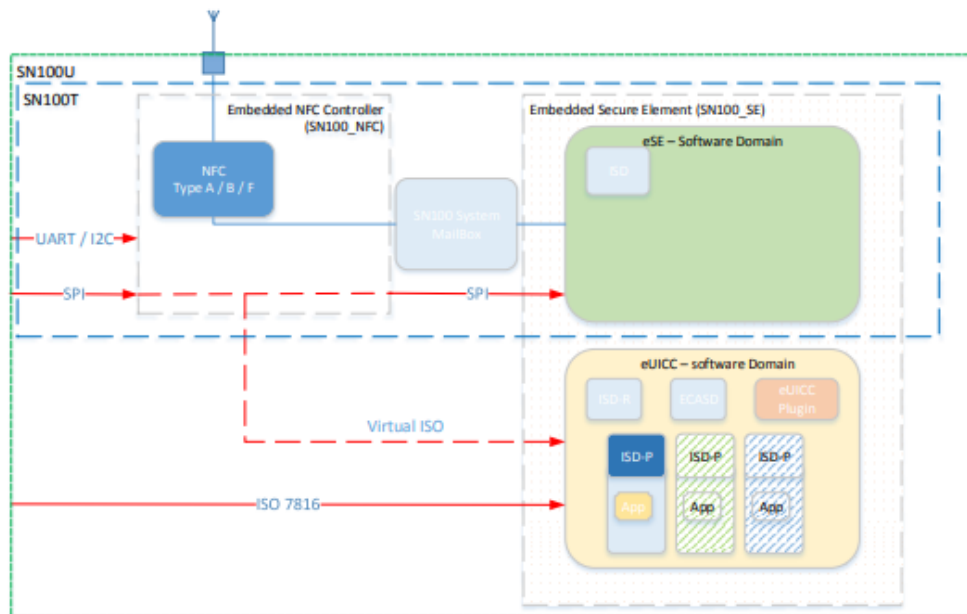
See [https://www.commoncriteriaportal.org/files/epfiles/SecurityTarget-Lite\\_SN100T\\_v1.1\\_20190418.pdf](https://www.commoncriteriaportal.org/files/epfiles/SecurityTarget-Lite_SN100T_v1.1_20190418.pdf); see also [https://www.emvco.com/wp-content/uploads/approved\\_products/uploaded/loa/MTA\\_LOA\\_SAEI\\_02859\\_24Nov20\\_SHORT.pdf](https://www.emvco.com/wp-content/uploads/approved_products/uploaded/loa/MTA_LOA_SAEI_02859_24Nov20_SHORT.pdf).

52. Claim 1 of the '360 Patent recites an “apparatus” comprising “a communication element which is connected to the coil and to a data processing component of an intelligent device and which emits search signals via the coil to receive a response from another intelligent device.” The Accused Products include a communication element which is connected to the coil and to a data processing component of an intelligent device and which emits search signals via the coil to receive a response from another intelligent device. For example, teardowns show that the Accused Products include an NFC antenna, NFC chip, and related hardware and software, as shown in the exemplary Samsung S21:









**Fig. 1.2:** SN100x Product Configurations

See [https://www.commoncriteriaportal.org/files/epfiles/SecurityTarget-Lite\\_SN100T\\_v1.1\\_20190418.pdf](https://www.commoncriteriaportal.org/files/epfiles/SecurityTarget-Lite_SN100T_v1.1_20190418.pdf); see also [https://www.emvco.com/wp-content/uploads/approved\\_products/uploaded/loa/MTA\\_LOA\\_SAE\\_L\\_02859\\_24Nov20\\_SHORT.pdf](https://www.emvco.com/wp-content/uploads/approved_products/uploaded/loa/MTA_LOA_SAE_L_02859_24Nov20_SHORT.pdf).

53. Claim 1 of the '360 Patent recites an “apparatus” comprising “a measuring device for monitoring a property of the transmission oscillator which outputs a control signal when ascertaining a change of the monitored property, the monitored property of the transmission oscillator includes the frequency or impedance of the transmission oscillator in resonance.” The Accused Products include a measuring device for monitoring a property of the transmission oscillator which outputs a control signal when ascertaining a change of the monitored property, the monitored property of the transmission oscillator includes the frequency or impedance of the transmission oscillator in resonance. For example, on information and belief, the Accused Products include low power modes for the NFC functionality that satisfy this limitation.

54. Claim 1 of the '360 Patent recites an “apparatus” comprising “a switching apparatus which is connected to the measuring device and the communication element and which switches on the communication element when it has received the control signal from the measuring device by connecting the communication element to an energy source.” The Accused Products include a switching apparatus which is connected to the measuring device and the communication element and which switches on the communication element when it has received the control signal from the measuring device by connecting the communication element to an energy source. For example, on information and belief, the Accused Products include low power modes for the NFC functionality that satisfy this limitation.

55. Samsung also knowingly and intentionally induces infringement of one or more claims of the '360 Patent in violation of 35 U.S.C. § 271(b). As of at least the filing and service of this complaint, Samsung has knowledge of the '360 Patent and the infringing nature of the Accused Products. Despite this knowledge of the '360 Patent, Samsung continues to actively encourage and instruct its customers and end users (for example, through user manuals and online instruction materials on its website, and other online publications cited above) to use the Accused Products in ways that directly infringe the '360 Patent, for example by utilizing the NFC functionality on the Accused Products, in an infringing manner. Samsung does so knowing and intending (or with willful blindness to the fact) that its customers and end users will commit these infringing acts. Samsung also continues to make, use, offer for sale, sell, and/or import the Accused Products, despite its knowledge of the '360 Patent, thereby specifically intending for and inducing its customers to infringe the '360 Patent through the customers' normal and customary use of the Accused Products.

56. Samsung has also infringed, and continues to infringe, one or more claims of the '360 Patent by selling, offering for sale, or importing into the United States, the Accused Products, knowing that the Accused Products constitute a material part of the inventions claimed in the '360 Patent, are especially made or adapted to infringe the '360 Patent, and are not staple articles or commodities of commerce suitable for non-infringing use. Samsung has been, and currently is, contributorily infringing the '360 Patent in violation of 35 U.S.C. §§ 271(c) and (f).

57. By making, using, offering for sale, selling and/or importing into the United States the Accused Products, Samsung has injured Plaintiff and is liable for infringement of the '360 Patent pursuant to 35 U.S.C. § 271.

58. As a result of Samsung's infringement of the '360 Patent, Plaintiff is entitled to monetary damages (past, present, and future) in an amount adequate to compensate for Samsung's infringement, but in no event less than a reasonable royalty for the use made of the invention by Samsung, together with interest and costs as fixed by the Court.

**PRAYER FOR RELIEF**

WHEREFORE, Plaintiff respectfully requests that this Court enter:

- a. A judgment in favor of Plaintiff that Samsung has infringed, either literally and/or under the doctrine of equivalents, the '706, '827, '249, and '360 Patents;
- b. A judgment and order requiring Samsung to pay Plaintiff its damages (past, present, and future), costs, expenses, and pre-judgment and post-judgment interest for Samsung's infringement of the '706, '827, '249, and '360 Patents;
- c. A judgment and order requiring Samsung to pay Plaintiff compulsory ongoing licensing fees, as determined by the Court in equity.
- d. A judgment and order requiring Samsung to provide an accounting and to pay

supplemental damages to Plaintiff, including without limitation, pre-judgment and post-judgment interest and compensation for infringing products released after the filing of this case that are not colorably different from the accused products;

e. A judgment and order finding that this is an exceptional case within the meaning of 35 U.S.C. § 285 and awarding to Plaintiff its reasonable attorneys' fees against Samsung; and

f. Any and all other relief as the Court may deem appropriate and just under the circumstances.

**DEMAND FOR JURY TRIAL**

Plaintiff, under Rule 38 of the Federal Rules of Civil Procedure, requests a trial by jury of any issues so triable by right.

Dated: September 15, 2021

Respectfully submitted,

/s/ Brett E. Cooper

Brett E. Cooper (NY SBN 4011011)

[bcooper@raklaw.com](mailto:bcooper@raklaw.com)

Reza Mirzaie (CA SBN 246953)

[rmirzaie@raklaw.com](mailto:rmirzaie@raklaw.com)

Marc A. Fenster (CA SBN 181067)

[mfenster@raklaw.com](mailto:mfenster@raklaw.com)

Seth Hasenour (TX SBN 24059910)

[shasenour@raklaw.com](mailto:shasenour@raklaw.com)

Drew B. Hollander (NY SBN 5378096)

[dhollander@raklaw.com](mailto:dhollander@raklaw.com)

RUSS AUGUST & KABAT

12424 Wilshire Blvd. 12th Floor

Los Angeles, CA 90025

Phone: (310) 826-7474

Facsimile: (310) 826-6991

*Attorneys for Plaintiff Aire Technology  
Limited*