



US 20050127850A1

(19) **United States**

(12) **Patent Application Publication**
Baarman et al.

(10) **Pub. No.: US 2005/0127850 A1**

(43) **Pub. Date: Jun. 16, 2005**

(54) **INDUCTIVELY POWERED APPARATUS**

(76) Inventors: **David W. Baarman**, Fennville, MI (US); **Stephen J. McPhilliamy**, Chicago, IL (US); **Christopher Houghton**, Chicago, IL (US)

Correspondence Address:
WARNER, NORCROSS & JUDD
IN RE: ALTICOR INC.
INTELLECTUAL PROPERTY GROUP
111 LYON STREET, N. W. STE 900
GRAND RAPIDS, MI 49503-2489 (US)

is a continuation-in-part of application No. 29/165,012, filed on Aug. 2, 2002, now Pat. No. D,476,094, and which is a continuation-in-part of application No. 29/165,005, filed on Aug. 2, 2002, now Pat. No. D,479,892, and which is a continuation-in-part of application No. 29/165,009, filed on Aug. 2, 2002, now Pat. No. D,475,471, and which is a continuation-in-part of application No. 29/165,011, filed on Aug. 2, 2002, now Pat. No. D,478,834.

(60) Provisional application No. 60/140,159, filed on Jun. 21, 1999. Provisional application No. 60/140,090, filed on Jun. 21, 1999.

(21) Appl. No.: **11/036,688**

(22) Filed: **Jan. 14, 2005**

Related U.S. Application Data

(60) Division of application No. 10/357,932, filed on Feb. 4, 2003, which is a continuation-in-part of application No. 10/133,860, filed on Apr. 26, 2002, now Pat. No. 6,731,071, and which is a continuation-in-part of application No. 09/592,194, filed on Jun. 12, 2000, now Pat. No. 6,436,299, and which is a continuation-in-part of application No. 10/246,155, filed on Sep. 18, 2002, now Pat. No. 6,825,620, and which is a continuation-in-part of application No. 10/175,095, filed on Jun. 18, 2002, now Pat. No. 6,673,250, which is a continuation-in-part of application No. 09/592,194, filed on Jun. 12, 2000, now Pat. No. 6,436,299. Said application No. 10/357,932 is a continuation-in-part of application No. 29/165,043, filed on Aug. 2, 2002, now Pat. No. D,476,095, and which is a continuation-in-part of application No. 29/165,008, filed on Aug. 2, 2002, now Pat. No. D,479,356, and which

Publication Classification

(51) **Int. Cl.⁷ H05B 41/16**
(52) **U.S. Cl. 315/248; 315/267**

(57) **ABSTRACT**

An inductive power supply system for providing power to one or more inductively powered devices. The system includes a mechanism for varying the physical distance or the respective orientation between the primary coil and secondary coil to control the amount of power supplied to the inductively powered device. In another aspect, the present invention is directed to an inductive power supply system having a primary coil and a receptacle disposed within the magnetic field generated by the primary coil. One or more inductively powered devices are placed randomly within the receptacle to receive power inductively from the primary coil. The power supply circuit includes circuitry for adjusting the power supplied to the primary coil to optimize operation based on the position and cumulative characteristics of the inductively powered device(s) disposed within the receptacle.

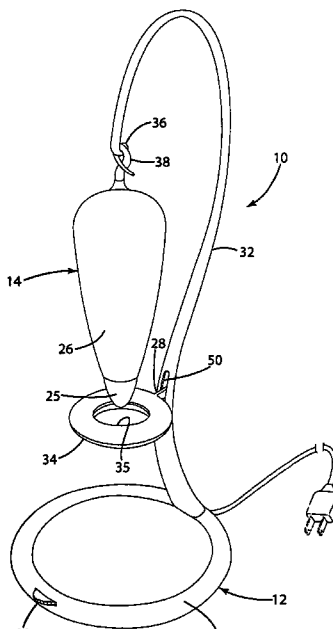

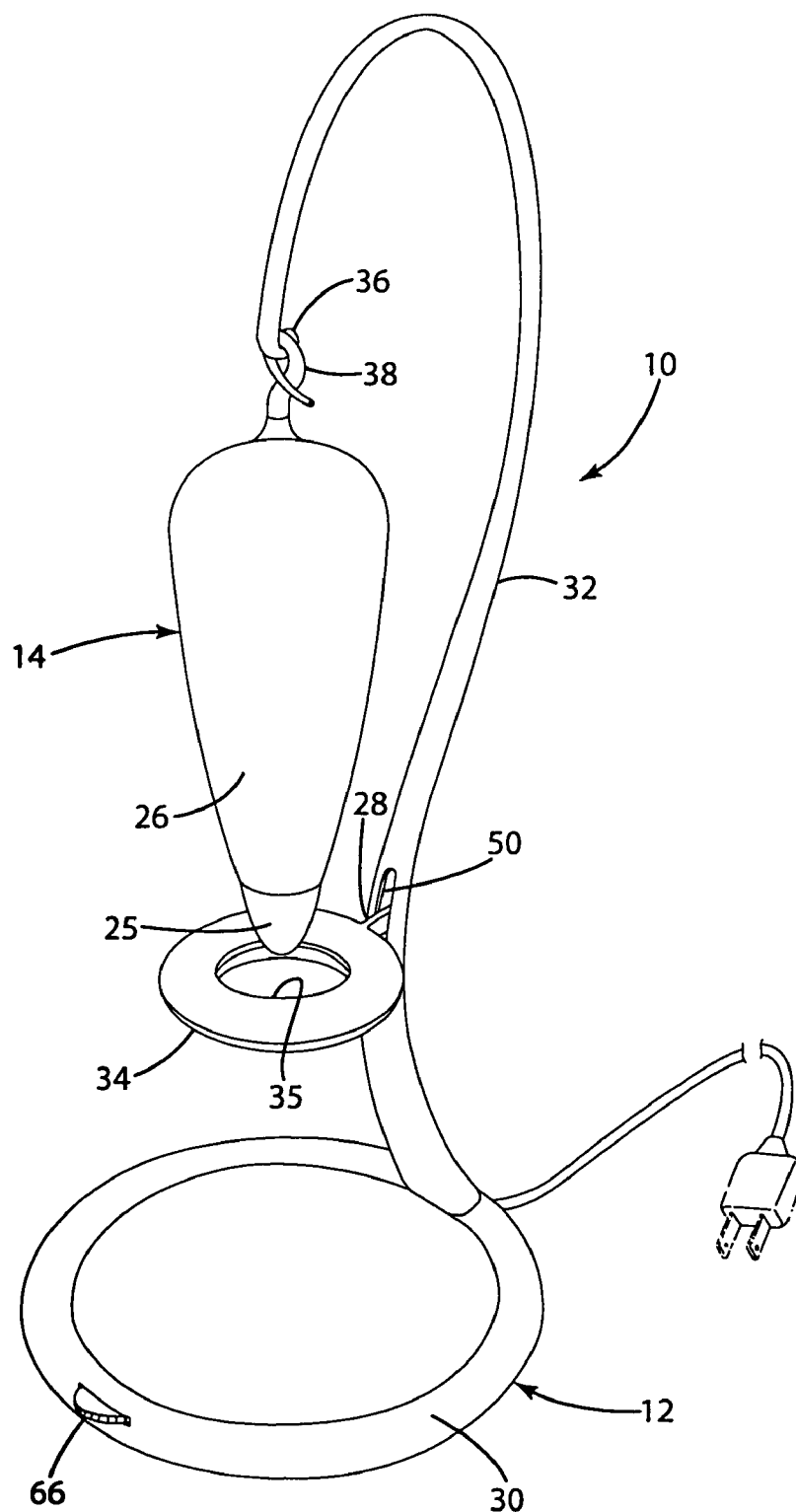

Fig. 1

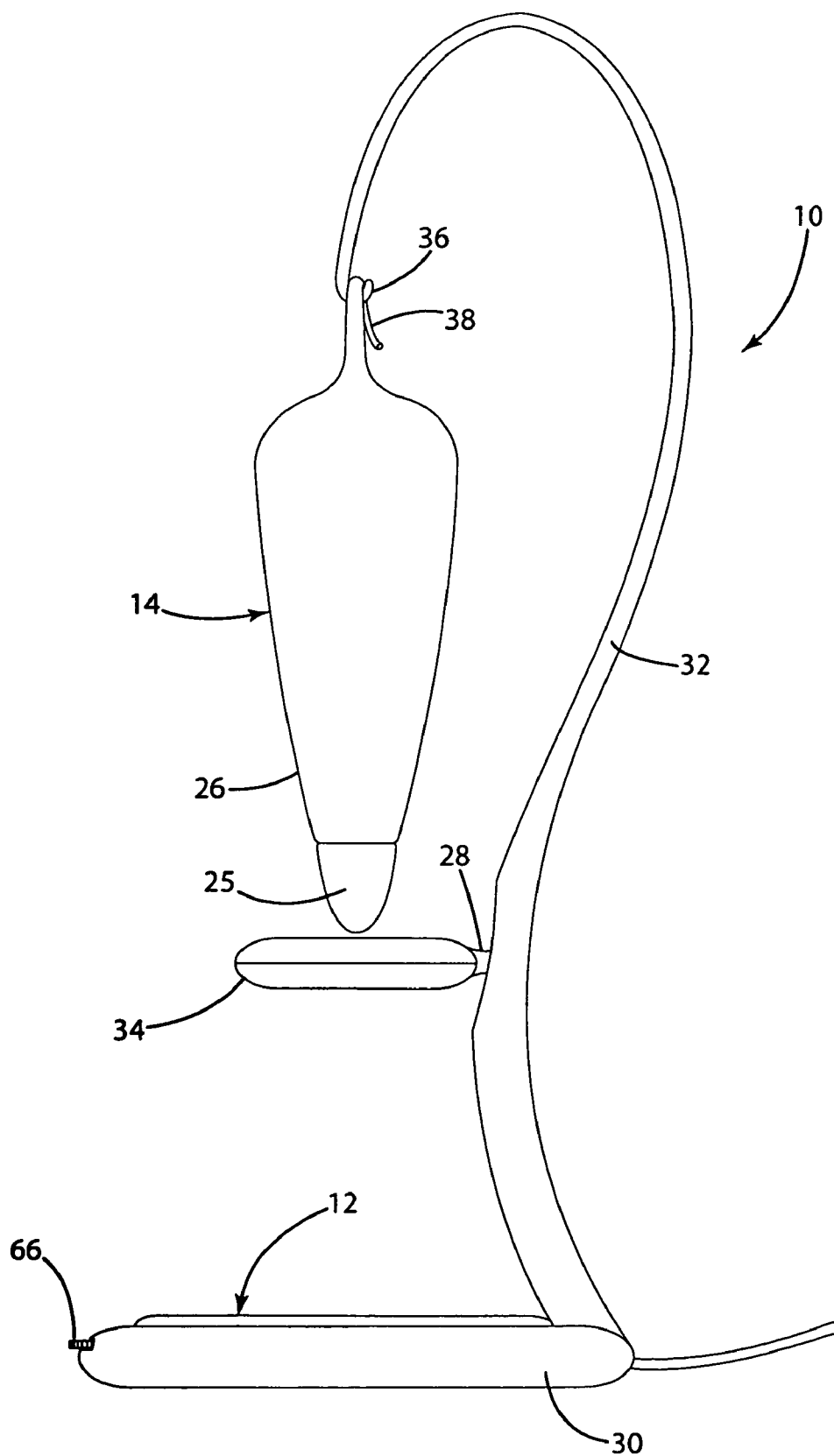

Fig. 2

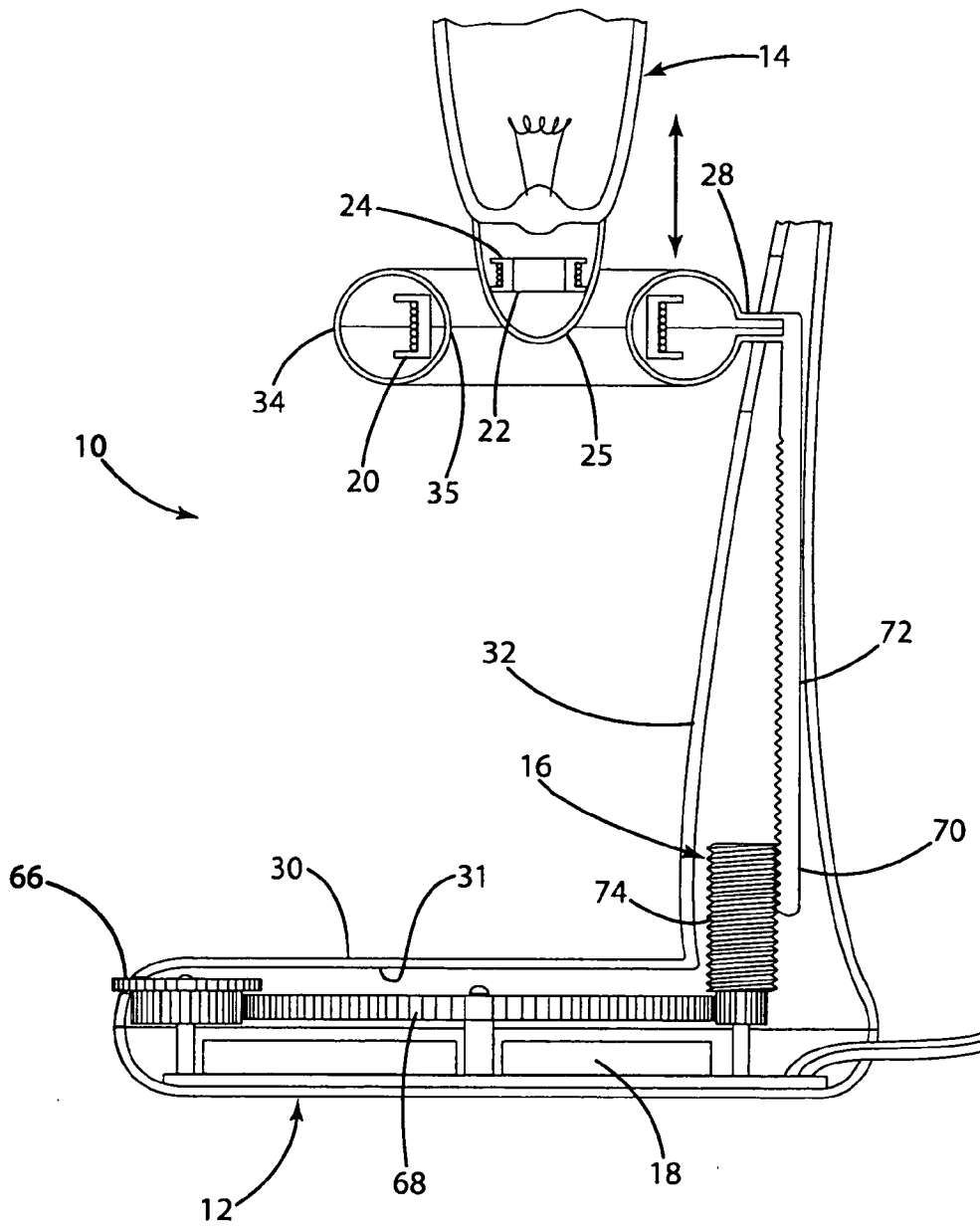

Fig. 3

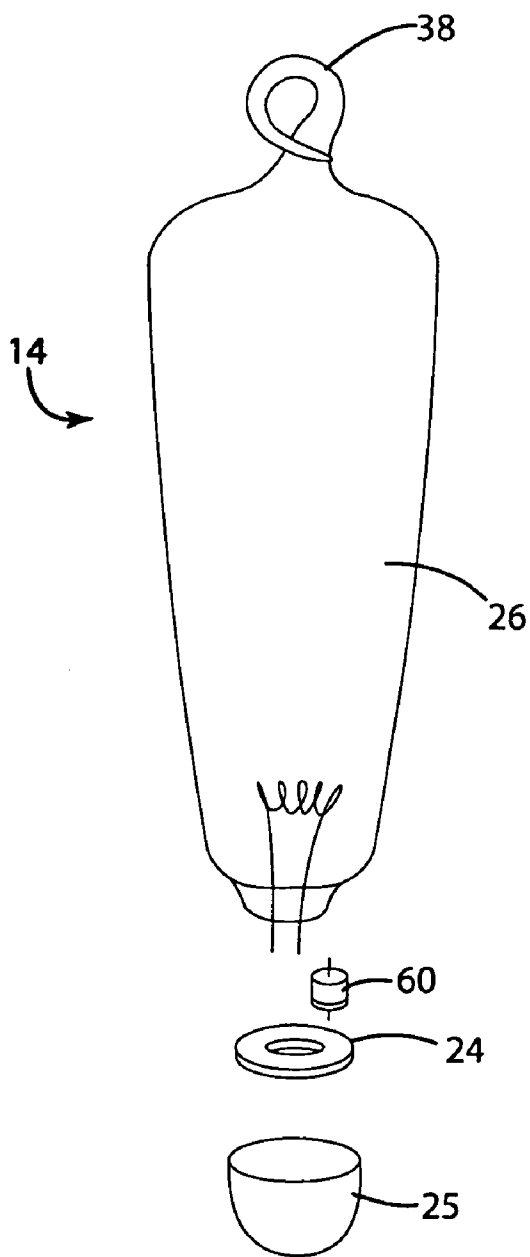

Fig. 4

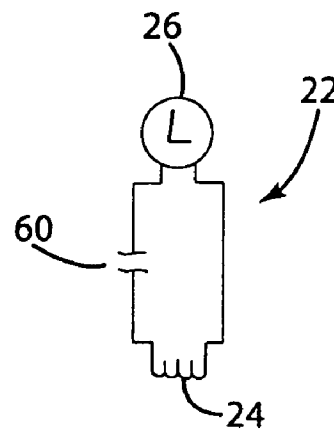

Fig. 5

Explore Litigation Insights

Docket Alarm provides insights to develop a more informed litigation strategy and the peace of mind of knowing you're on top of things.

Real-Time Litigation Alerts



Keep your litigation team up-to-date with **real-time alerts** and advanced team management tools built for the enterprise, all while greatly reducing PACER spend.

Our comprehensive service means we can handle Federal, State, and Administrative courts across the country.

Advanced Docket Research



With over 230 million records, Docket Alarm's cloud-native docket research platform finds what other services can't. Coverage includes Federal, State, plus PTAB, TTAB, ITC and NLRB decisions, all in one place.

Identify arguments that have been successful in the past with full text, pinpoint searching. Link to case law cited within any court document via Fastcase.

Analytics At Your Fingertips



Learn what happened the last time a particular judge, opposing counsel or company faced cases similar to yours.

Advanced out-of-the-box PTAB and TTAB analytics are always at your fingertips.

API

Docket Alarm offers a powerful API (application programming interface) to developers that want to integrate case filings into their apps.

LAW FIRMS

Build custom dashboards for your attorneys and clients with live data direct from the court.

Automate many repetitive legal tasks like conflict checks, document management, and marketing.

FINANCIAL INSTITUTIONS

Litigation and bankruptcy checks for companies and debtors.

E-DISCOVERY AND LEGAL VENDORS

Sync your system to PACER to automate legal marketing.