

<b>Notice of Allowability</b>	<b>Application No.</b> 12/896,993	<b>Applicant(s)</b> ASTELY ET AL.	
	<b>Examiner</b> MD TALUKDER	<b>Art Unit</b> 2648	<b>AIA (First Inventor to File) Status</b> No

**-- The MAILING DATE of this communication appears on the cover sheet with the correspondence address--**  
All claims being allowable, PROSECUTION ON THE MERITS IS (OR REMAINS) CLOSED in this application. If not included herewith (or previously mailed), a Notice of Allowance (PTOL-85) or other appropriate communication will be mailed in due course. **THIS NOTICE OF ALLOWABILITY IS NOT A GRANT OF PATENT RIGHTS.** This application is subject to withdrawal from issue at the initiative of the Office or upon petition by the applicant. See 37 CFR 1.313 and MPEP 1308.

1.  This communication is responsive to 03/09/2016.  
 A declaration(s)/affidavit(s) under **37 CFR 1.130(b)** was/were filed on \_\_\_\_\_.
2.  An election was made by the applicant in response to a restriction requirement set forth during the interview on \_\_\_\_\_; the restriction requirement and election have been incorporated into this action.
3.  The allowed claim(s) is/are 1-52. As a result of the allowed claim(s), you may be eligible to benefit from the **Patent Prosecution Highway** program at a participating intellectual property office for the corresponding application. For more information, please see [http://www.uspto.gov/patents/init\\_events/pph/index.jsp](http://www.uspto.gov/patents/init_events/pph/index.jsp) or send an inquiry to [PPHfeedback@uspto.gov](mailto:PPHfeedback@uspto.gov).
4.  Acknowledgment is made of a claim for foreign priority under 35 U.S.C. § 119(a)-(d) or (f).

**Certified copies:**

- a)  All    b)  Some    \*c)  None of the:
1.  Certified copies of the priority documents have been received.
  2.  Certified copies of the priority documents have been received in Application No. \_\_\_\_\_.
  3.  Copies of the certified copies of the priority documents have been received in this national stage application from the International Bureau (PCT Rule 17.2(a)).

\* Certified copies not received: \_\_\_\_\_.

Applicant has THREE MONTHS FROM THE "MAILING DATE" of this communication to file a reply complying with the requirements noted below. Failure to timely comply will result in ABANDONMENT of this application.  
**THIS THREE-MONTH PERIOD IS NOT EXTENDABLE.**

5.  CORRECTED DRAWINGS ( as "replacement sheets") must be submitted.  
 including changes required by the attached Examiner's Amendment / Comment or in the Office action of Paper No./Mail Date \_\_\_\_\_.  
**Identifying indicia such as the application number (see 37 CFR 1.84(c)) should be written on the drawings in the front (not the back) of each sheet. Replacement sheet(s) should be labeled as such in the header according to 37 CFR 1.121(d).**
6.  DEPOSIT OF and/or INFORMATION about the deposit of BIOLOGICAL MATERIAL must be submitted. Note the attached Examiner's comment regarding REQUIREMENT FOR THE DEPOSIT OF BIOLOGICAL MATERIAL.

**Attachment(s)**

- |  |  |
|--|--|
| 1. <input checked="" type="checkbox"/> Notice of References Cited (PTO-892)  | 5. <input checked="" type="checkbox"/> Examiner's Amendment/Comment                  |
| 2. <input checked="" type="checkbox"/> Information Disclosure Statements (PTO/SB/08),<br>Paper No./Mail Date _____ | 6. <input checked="" type="checkbox"/> Examiner's Statement of Reasons for Allowance |
| 3. <input type="checkbox"/> Examiner's Comment Regarding Requirement for Deposit<br>of Biological Material         | 7. <input type="checkbox"/> Other _____.   |
| 4. <input type="checkbox"/> Interview Summary (PTO-413),<br>Paper No./Mail Date _____.                             |  |

/MD TALUKDER/ Examiner, Art Unit 2648	
--	--

Art Unit: 2648

1. The present application is being examined under the pre-AIA first to invent provisions.
  
2. It would be of great assistance to the office if all incoming papers pertaining to a filed application carried the following items:
  - i. Application number (checked for accuracy, including series code and serial no.).
  - ii. Group art unit number (copied from most recent Office communication).
  - iii. Filing date.
  - iv. Name of the examiner who prepared the most recent Office action.
  - v. Title of invention.
  - vi. Confirmation number (See MPEP § 503).

***Examiner's Amendment***

3. An examiner's amendment to the record appears below. Should the changes and/or additions be unacceptable to applicant, an amendment may be filed as provided by 37 CFR 1.312. To ensure consideration of such an amendment, it MUST be submitted no later than the payment of the issue fee. Authorization for this examiner's amendment was given in a telephone interview with Edward Roney on March 9<sup>th</sup>, 2016.

**Amended as follows:**

Art Unit: 2648

1. (Currently amended) A method implemented by a base station of receiving control information from a user terminal, the method comprising:

scheduling downlink transmissions to a first user terminal on a single downlink component carrier associated with a primary cell and a second user terminal on multiple downlink component carriers including the single downlink component carrier associated with the primary cell;

receiving control information associated with the downlink transmissions to the first user terminal on a first set of radio resources on an uplink component carrier associated with the primary cell, wherein the first set of radio resources is reserved for user terminals scheduled to receive downlink transmissions on the single downlink component carrier associated with the primary cell; **[[and]]**

receiving control information associated with the downlink transmissions to the second user terminal on a second set of radio resources on the uplink component carrier associated with the primary cell, wherein the second set of radio resources is reserved for user terminals scheduled to receive downlink transmissions on the multiple downlink component carriers and the second set of resources are additional resources as compared to the first set of resources; **and**

**transmitting, on the single downlink component carrier, an indication to assign the second set of radio resources when the second user terminal is scheduled to receive the downlink transmissions on the multiple downlink component carriers.**

Art Unit: 2648

9. (Currently amended) A base station comprising:

a transmitter to transmit user data on one or more downlink component carriers to a first user terminal and a second user terminal; and

a controller to schedule downlink transmissions to the first user terminal and the second user terminal, the controller configured to:

schedule downlink transmissions to the first user terminal on a single downlink component carrier associated with a primary cell and the second user terminal on multiple downlink component carriers including the single downlink component carrier associated with the primary cell;

receive control information associated with the downlink transmissions to the first user terminal on a first set of radio resources on an uplink component carrier associated with the primary cell, wherein the first set of radio resources is reserved for user terminals scheduled to receive downlink transmissions on the single downlink component carrier associated with the primary cell;

[[and]]

receive control information associated with the downlink transmissions to the second user terminal on a second set of radio resources on the uplink component carrier associated with the primary cell, wherein the second set of radio resources is reserved for user terminals scheduled to receive downlink transmissions on the multiple downlink component carriers and the second set of resources are additional resources as compared to the first set of resources; and

transmit, on the single downlink component carrier, an indication to assign the second set of radio resources when the second user terminal is scheduled to receive the downlink transmissions on the multiple downlink component carriers.



Art Unit: 2648

17. (Currently amended) A method implemented by a user terminal of transmitting control information in a mobile communication network, the method comprising:

receiving an assignment of radio resources for downlink transmissions from a base station;

transmitting, on a first set of radio resources on an uplink component carrier associated with a primary cell, control information associated with the downlink transmissions responsive to receiving an assignment of a single downlink component carrier associated with the primary cell for the downlink transmission, wherein the first set of radio resources is reserved for user terminals scheduled to receive downlink transmissions on the single downlink component carrier associated with the primary cell; **[[and]]**

transmitting, on a second set of radio resources on the uplink component carrier associated with the primary cell, control information associated with the downlink transmissions responsive to receiving an assignment of multiple downlink component carriers including the single downlink component carrier associated with the primary cell for the downlink transmission, wherein the second set of radio resources is reserved for user terminals scheduled to receive downlink transmissions on the multiple downlink component carriers and the second set of resources are additional resources as compared to the first set of resources; **and**

**receiving, on the single downlink component carrier, an indication to assign the second set of radio resources when the user terminal is scheduled to receive the downlink transmissions on the multiple downlink component carriers.**

Art Unit: 2648

25. (Currently amended) A user terminal for mobile communications, the user terminal comprising:

a receiver to receive downlink transmissions from a base station;

a transmitter to transmit control information associated with the downlink transmission to a base station; and

a controller to select radio resources for transmission of control information associated with the downlink transmissions, the controller configured to:

select a first set of radio resources on an uplink component carrier associated with a primary cell responsive to receiving an assignment of a single downlink component carrier associated with the primary cell for the downlink transmission, wherein the first set of radio resources is reserved for user terminals scheduled to receive downlink transmissions on the single downlink component carrier associated with the primary cell; **[[and]]**

select a second set of radio resources on the uplink component carrier associated with the primary cell responsive to receiving an assignment of multiple downlink component carriers including the single downlink component carrier associated with the primary cell for the downlink transmission, wherein the second set of radio resources is reserved for user terminals scheduled to receive downlink transmissions on the multiple downlink component carriers and the second set of resources are additional resources as compared to the first set of resources; **and**

**receive, on the single downlink component carrier, an indication to assign the second set of radio resources when the user terminal is scheduled to receive the downlink transmissions on the multiple downlink component carriers.**

Art Unit: 2648

33. (Currently amended) A method implemented by a user terminal in a mobile communication network, the method comprising:

receiving an assignment of radio resources for a downlink transmissions from a base station;

transmitting control information associated with the downlink transmission on a first set of radio resources on an uplink component carrier associated with a primary cell responsive to receiving an assignment of a first downlink component carrier associated with the primary cell for the downlink transmission, wherein the first set of radio resources is reserved for user terminals scheduled to receive downlink transmissions on the first downlink component carrier associated with the primary cell; **[[and]]**

transmitting control information associated with the downlink transmission on a second set of radio resources on the uplink component carrier associated with the primary cell responsive to receiving an assignment of the first downlink component carrier associated with the primary cell and a second ~~single~~ downlink component carrier associated with a non-primary cell for the downlink transmission, wherein the second set of radio resources is reserved for user terminals scheduled to receive downlink transmissions on the first downlink component carrier and the second ~~single~~ downlink component carrier and the second set of resources are additional resources as compared to the first set of resources; **and**

**receiving, on the first downlink component carrier, an indication to assign the second set of radio resources when the user terminal is scheduled to receive the downlink transmissions on the first and second downlink component carriers.**

Art Unit: 2648

34. (Currently amended) A user terminal for mobile communications, the user terminal comprising:

- a receiver to receive downlink transmissions from a base station;

- a transmitter to transmit control information associated with the downlink transmission to a base station; and

- a controller to select radio resources for transmission of control information associated with downlink transmissions, the controller configured to:

  - select a first set of radio resources on an uplink component carrier associated with a primary cell responsive to receiving an assignment of a first downlink component carrier associated with the primary cell for the downlink transmission, wherein the first set of radio resources is reserved for user terminals scheduled to receive downlink transmissions on the first downlink component carrier associated with the primary cell; **[[and]]**

  - select a second set of radio resources on the uplink component carrier associated with the primary cell responsive to receiving an assignment of the first downlink component carrier associated with the primary cell and a second ~~single~~-downlink component carrier associated with a non-primary cell for the downlink transmission, wherein the second set of radio resources is reserved for user terminals scheduled to receive downlink transmissions on the first downlink component carrier and the second ~~single~~-downlink component carrier and the second set of resources are additional resources as compared to the first set of resources; **and**

    - receive, on the first downlink component carrier, an indication to assign the second set of radio resources when the user terminal is scheduled to receive the downlink transmissions on the first and second downlink component carriers.**

Art Unit: 2648

43. (Currently amended) A method implemented by a base station of receiving control information from a first user terminal and a second user terminal, the method comprising:

scheduling downlink transmissions to the first user terminal on a single downlink component carrier associated with a primary cell and the second user terminal on multiple downlink component carriers including the single downlink component carrier associated with the primary cell; and

receiving on a first set or a second set of resources on an uplink component carrier associated with a primary cell, including:

receiving control information associated with the downlink transmissions to the first user terminal on the first set of radio resources on the uplink component carrier associated with the primary cell, wherein the first set of radio resources is reserved for user terminals scheduled to receive downlink transmissions on the single downlink component carrier associated with the primary cell; **[[and]]**

receiving control information associated with the downlink transmissions to the second user terminal on the second set of radio resources on the uplink component carrier associated with the primary cell, wherein the second set of radio resources is reserved for user terminals scheduled to receive downlink transmissions on the multiple downlink component carriers and the second set of resources are additional resources as compared to the first set of resources; **and**

**transmitting, on the single downlink component carrier, an indication to assign the second set of radio resources when the second user terminal is scheduled to receive the downlink transmissions on the multiple downlink component carriers.**

Art Unit: 2648

44. (Currently amended) A base station comprising:

a transmitter to transmit user data on one or more downlink component carriers to a first user terminal and a second user terminal; and

a controller to schedule downlink transmissions to the first user terminal and the second user terminal, the controller configured to:

schedule downlink transmissions to the first user terminal on a single downlink component carrier associated with the primary cell and the second user terminal on multiple downlink component carriers including the single downlink component carrier associated with the primary cell; and

receiving on a first set or a second set of resources on an uplink component carrier associated with a primary cell, including:

receive control information associated with the downlink transmissions to the first user terminal on the first set of radio resources on the uplink component carrier associated with the primary cell, wherein the first set of radio resources is reserved for user terminals scheduled to receive downlink transmissions on the single downlink component carrier associated with the primary cell; **[[and]]**

receive control information associated with the downlink transmissions to the second user terminal on the second set of radio resources on the uplink component carrier associated with the primary cell, wherein the second set of radio resources is reserved for user terminals scheduled to receive downlink transmissions on the multiple downlink component carriers and the second set of resources are additional resources as compared to the first set of resources; **and**

**transmit, on the single downlink component carrier, an indication to assign the second set of radio resources when the second user terminal is scheduled to receive the downlink transmissions on the multiple downlink component carriers.**

***Reasons for Allowance***

4. Claims 1-52 are allowed over the prior art record.

The following is an examiner's statement of reasons for allowance:

The following is an examiner's statement of reasons for allowance: Interpreting the claims in light of the specification and based on applicant's argument filed on 02/12/2016 examiner finds the claimed invention is patentably distinct from the prior art of record. The prior art does not expressly teach or render obvious the invention as recited in the independent claims.

Any comments considered necessary by applicant must be submitted no later than the payment of the issue fee and, to avoid processing delays, should preferably accompany the issue fee. Such submissions should be clearly labeled "Comments on Statement of Reasons for Allowance."

***Conclusion***

Any inquiry concerning this communication or earlier communications from the examiner should be directed to MD TALUKDER whose telephone number is (571)270-3222. The examiner can normally be reached on Monday to Friday (Alt Friday off) from (9:30 to 4:00).

Art Unit: 2648

If attempts to reach the examiner by telephone are unsuccessful, the examiner's supervisor, Wesley Kim can be reached on 571-272-7867. The fax phone number for the organization where this application or proceeding is assigned is 571-273-8300. Information regarding the status of an application may be obtained from the Patent Application Information Retrieval (PAIR) system. Status information for published applications may be obtained from either Private PAIR or Public PAIR. Status information for unpublished applications is available through Private PAIR only. For more information about the PAIR system, see <http://pair-direct.uspto.gov>. Should you have questions on access to the Private PAIR system, contact the Electronic Business Center (EBC) at 866-217-9197 (toll-free). If you would like assistance from a USPTO Customer Service Representative or access to the automated information system, call 800-786-9199 (IN USA OR CANADA) or 571-272-1000.

/MD TALUKDER/

Examiner, Art Unit 2648



<b>Notice of References Cited</b>	Application/Control No. 12/896,993	Applicant(s)/Patent Under Reexamination ASTELY ET AL.	
	Examiner MD TALUKDER	Art Unit 2648	Page 1 of 3

**U.S. PATENT DOCUMENTS**

*		Document Number Country Code-Number-Kind Code	Date MM-YYYY	Name	CPC Classification	US Classification
*	A	US-2002/0160784 A1	10-2002	Kuwahara, Soichi	H04W28/26	455/452.1
*	B	US-2010/0003997 A1	01-2010	KOYANAGI; Kenichiro	H04L1/0003	455/450
*	C	US-2010/0098012 A1	04-2010	Bala; Erdem	H04L5/001	370/329
*	D	US-2010/0208679 A1	08-2010	Papasakellariou; Aris	H04L1/1614	370/329
*	E	US-2010/0232373 A1	09-2010	Nory; Ravikiran	H04W72/1289	370/329
*	F	US-2010/0271970 A1	10-2010	Pan; Kyle Jung-Lin	H04L1/0026	370/252
*	G	US-2010/0285809 A1	11-2010	Lindstrom; Magnus	H04L5/001	455/450
*	H	US-2010/0296389 A1	11-2010	Khandekar; Aamod Dinkar	H04L5/0007	370/216
*	I	US-2010/0322173 A1	12-2010	Marinier; Paul	H04W76/048	370/329
*	J	US-2011/0007695 A1	01-2011	Choi; Hyung-Nam	H04L5/0007	370/329
*	K	US-2011/0007699 A1	01-2011	Moon; Sung Ho	H04L5/0053	370/329
*	L	US-2011/0081913 A1	04-2011	Lee; Jung A.	H04L5/003	455/450
*	M	US-2011/0081932 A1	04-2011	Astely; David	H04L5/001	455/509

**FOREIGN PATENT DOCUMENTS**

*		Document Number Country Code-Number-Kind Code	Date MM-YYYY	Country	Name	CPC Classification
	N					
	O					
	P					
	Q					
	R					
	S					
	T					

**NON-PATENT DOCUMENTS**

*		Include as applicable: Author, Title Date, Publisher, Edition or Volume, Pertinent Pages)
	U	
	V	
	W	
	X	

\*A copy of this reference is not being furnished with this Office action. (See MPEP § 707.05(a).)  
Dates in MM-YYYY format are publication dates. Classifications may be US or foreign.

<b>Notice of References Cited</b>	Application/Control No. 12/896,993	Applicant(s)/Patent Under Reexamination ASTELY ET AL.	
	Examiner MD TALUKDER	Art Unit 2648	Page 2 of 3

**U.S. PATENT DOCUMENTS**

*		Document Number Country Code-Number-Kind Code	Date MM-YYYY	Name	CPC Classification	US Classification
*	A	US-2011/0243039 A1	10-2011	PAPASAKELLARIOU; Aris	H04L1/1861	370/280
*	B	US-2011/0310856 A1	12-2011	Hariharan; Priya	H04L1/1607	370/336
*	C	US-2012/0020317 A1	01-2012	Ishii; Hiroyuki	H04L1/1854	370/329
*	D	US-2012/0051306 A1	03-2012	Chung; Jae Hoon	H04L1/1893	370/329
*	E	US-2012/0082125 A1	04-2012	Huang; Yada	H04L5/0007	370/329
*	F	US-2012/0140708 A1	06-2012	Choudhury; Sayantan	H04W72/082	370/328
*	G	US-8,265,030 B2	09-2012	Miki; Nobuhiko	H04W72/1257	370/330
*	H	US-2012/0314675 A1	12-2012	Vujcic; Dragan	H04L5/001	370/329
*	I	US-2013/0010721 A1	01-2013	Aiba; Tatsushi	H04W72/0406	370/329
*	J	US-2013/0003700 A1	01-2013	Zhang; Jian	H04W76/028	370/331
*	K	US-2013/0034073 A1	02-2013	Aiba; Tatsushi	H04L1/0026	370/329
*	L	US-8,447,343 B2	05-2013	Gerstenberger; Dirk	H04W52/10	370/248
*	M	US-2013/0136084 A1	05-2013	ZHANG; Yuantao	H04W72/0413	370/329

**FOREIGN PATENT DOCUMENTS**

*		Document Number Country Code-Number-Kind Code	Date MM-YYYY	Country	Name	Classification
	N					
	O					
	P					
	Q					
	R					
	S					
	T					

**NON-PATENT DOCUMENTS**

*		Include as applicable: Author, Title Date, Publisher, Edition or Volume, Pertinent Pages)
	U	
	V	
	W	
	X	

\*A copy of this reference is not being furnished with this Office action. (See MPEP § 707.05(a).)  
Dates in MM-YYYY format are publication dates. Classifications may be US or foreign.

<b>Notice of References Cited</b>	Application/Control No. 12/896,993	Applicant(s)/Patent Under Reexamination ASTELY ET AL.	
	Examiner MD TALUKDER	Art Unit 2648	Page 3 of 3

**U.S. PATENT DOCUMENTS**

*	Document Number Country Code-Number-Kind Code	Date MM-YYYY	Name	CPC Classification	US Classification
*	A	US-8,472,368 B2	06-2013	Baldemair; Robert	H04L5/0053 370/318
*	B	US-8,634,358 B2	01-2014	Damnjanovic; Jelena M.	H04L1/1861 370/329
*	C	US-8,792,830 B2	07-2014	Lim; Suhwan	H04L25/02 375/260
	D	US-			
	E	US-			
	F	US-			
	G	US-			
	H	US-			
	I	US-			
	J	US-			
	K	US-			
	L	US-			
	M	US-			

**FOREIGN PATENT DOCUMENTS**

*	Document Number Country Code-Number-Kind Code	Date MM-YYYY	Country	Name	Classification
	N				
	O				
	P				
	Q				
	R				
	S				
	T				

**NON-PATENT DOCUMENTS**

*	Document Number Country Code-Number-Kind Code	Date MM-YYYY	Country	Name	Classification
	U	Include as applicable: Author, Title Date, Publisher, Edition or Volume, Pertinent Pages)			
	V				
	W				
	X				

\*A copy of this reference is not being furnished with this Office action. (See MPEP § 707.05(a).)  
Dates in MM-YYYY format are publication dates. Classifications may be US or foreign.

<b>Issue Classification</b> 	<b>Application/Control No.</b> 12896993	<b>Applicant(s)/Patent Under Reexamination</b> ASTELY ET AL.
	<b>Examiner</b> MD TALUKDER	<b>Art Unit</b> 2648

CPC						
Symbol					Type	Version
H04L		5		0053	F	2013-01-01
H04L		5		0005	A	2013-01-01
H04L		5		001	I	2013-01-01
H04L		5		0094	I	2013-01-01
H04W		8		24	A	2013-01-01
H04W		28		26	A	2013-01-01
H04W		48		16	A	2013-01-01
H04W		72		0453	A	2013-01-01
H04W		72		1273	A	2013-01-01

CPC Combination Sets				
Symbol	Type	Set	Ranking	Version

/MD TALUKDER/ Examiner.Art Unit 2648  (Assistant Examiner)	03/16/2016  (Date)	<b>Total Claims Allowed:</b>  52	
/MD TALUKDER/ Examiner.Art Unit 2648  (Primary Examiner)	03/16/2016  (Date)	O.G. Print Claim(s)  1	O.G. Print Figure  10

<b>Issue Classification</b> 	<b>Application/Control No.</b> 12896993	<b>Applicant(s)/Patent Under Reexamination</b> ASTELY ET AL.
	<b>Examiner</b> MD TALUKDER	<b>Art Unit</b> 2648

US ORIGINAL CLASSIFICATION					INTERNATIONAL CLASSIFICATION								
CLASS		SUBCLASS			CLAIMED				NON-CLAIMED				
455		509			H	0	4	B	7 / 00 (2006.01.01)				
<b>CROSS REFERENCE(S)</b>													
CLASS	SUBCLASS (ONE SUBCLASS PER BLOCK)												
455	522	456.6	137	103									
370	329	331											

/MD TALUKDER/ Examiner.Art Unit 2648  (Assistant Examiner)	03/16/2016  (Date)	<b>Total Claims Allowed:</b>  52	
/MD TALUKDER/ Examiner.Art Unit 2648  (Primary Examiner)	03/16/2016  (Date)	O.G. Print Claim(s)  1	O.G. Print Figure  10





UNITED STATES PATENT AND TRADEMARK OFFICE

UNITED STATES DEPARTMENT OF COMMERCE  
 United States Patent and Trademark Office  
 Address: COMMISSIONER FOR PATENTS  
 P.O. Box 1450  
 Alexandria, Virginia 22313-1450  
 www.uspto.gov

BIB DATA SHEET

CONFIRMATION NO. 1015

<b>SERIAL NUMBER</b> 12/896,993	<b>FILING or 371(c) DATE</b> 10/04/2010 <b>RULE</b>	<b>CLASS</b> 455	<b>GROUP ART UNIT</b> 2648	<b>ATTORNEY DOCKET NO.</b> 4015-6942 / P30138-US2	
<b>APPLICANTS</b> <b>INVENTORS</b> David Astely, Bromma, SWEDEN; Robert Baldemair, Solna, SWEDEN; Dirk Gerstenberger, Stockholm, SWEDEN; Daniel Larsson, Solna, SWEDEN; Lars Lindbom, Karlstad, SWEDEN; Stefan Parkvall, Stockholm, SWEDEN; <b>** CONTINUING DATA *****</b> This appln claims benefit of 61/248,661 10/05/2009 <b>** FOREIGN APPLICATIONS *****</b> <b>** IF REQUIRED, FOREIGN FILING LICENSE GRANTED **</b> 10/18/2010					
Foreign Priority claimed <input type="checkbox"/> Yes <input checked="" type="checkbox"/> No 35 USC 119(a-d) conditions met <input type="checkbox"/> Yes <input checked="" type="checkbox"/> No Verified and Acknowledged <u>/MD K TALUKDER/</u> Examiner's Signature	<input type="checkbox"/> Met after Allowance Initials _____	<b>STATE OR COUNTRY</b> SWEDEN	<b>SHEETS DRAWINGS</b> 12	<b>TOTAL CLAIMS</b> 52 <del>34</del>	<b>INDEPENDENT CLAIMS</b> 8 <del>8</del>
<b>ADDRESS</b> COATS & BENNETT, PLLC 1400 Crescent Green, Suite 300 Cary, NC 27518 UNITED STATES					
<b>TITLE</b> PUCCH Resource Allocation for Carrier Aggregation in LTE-Advanced					
<b>FILING FEE RECEIVED</b> 4888	FEES: Authority has been given in Paper No. _____ to charge/credit DEPOSIT ACCOUNT No. _____ for following:		<input type="checkbox"/> All Fees <input type="checkbox"/> 1.16 Fees (Filing) <input type="checkbox"/> 1.17 Fees (Processing Ext. of time) <input type="checkbox"/> 1.18 Fees (Issue) <input type="checkbox"/> Other _____ <input type="checkbox"/> Credit		

<b>Search Notes</b>  	<b>Application/Control No.</b>  12896993	<b>Applicant(s)/Patent Under Reexamination</b>  ASTELY ET AL.
	<b>Examiner</b>  MD TALUKDER	<b>Art Unit</b>  2648

<b>CPC- SEARCHED</b>		
<b>Symbol</b>	<b>Date</b>	<b>Examiner</b>
H04W88/08, H04W72/044, H04W72/042	4/22/2014 & 4/30/2014 & 10/31/2014	
H04W52/367, H04W52/12, H04W52/40	4/22/2014 & 4/30/2014 & 10/31/2014	Talukder
H04L29/08657, G01S5/0252, G01S5/02	4/22/2014 & 4/30/2014 & 10/31/2014	Talukder
H04B1/3833, H04M1/0247, H04M1/0237	4/22/2014 & 4/30/2014	Talukder
H03F3/211, H04B7/0617, H04B7/0669	4/22/2014 & 4/30/2014	
H04W88/08, H04W72/044, H04W72/042, H04W52/367, H04W52/12, H04W52/40, H04L29/08657, G01S5/0252, G01S5/02, H04B1/3833, H04M1/0247, H04M1/0237	10/13/2015	Talukder
H04W88/08, H04W72/044, H04W72/042, H04W52/367, H04W52/12, H04W52/40, H04L29/08657, G01S5/0252, G01S5/02, H04B1/3833, H04M1/0247, H04M1/0237	3/16/2016	Talukder

<b>CPC COMBINATION SETS - SEARCHED</b>		
<b>Symbol</b>	<b>Date</b>	<b>Examiner</b>

<b>US CLASSIFICATION SEARCHED</b>			
<b>Class</b>	<b>Subclass</b>	<b>Date</b>	<b>Examiner</b>
455	509,522,456.6,137,103,575	12/11/2012	Talukder
370	329,252,331	12/11/2012	Talukder
455	Text	6/17/2013	Talukder
370	329,341,348,395.4	6/26/2013	Talukder
455	All	10/13/2015	Talukder
455	509,522,456.6,137,103,575	3/9/2016	Talukder
370	29,252,331	3/9/2016	

--	--



## SEARCH NOTES

Search Notes	Date	Examiner
East Search	12/10/2012	talukder
East Search	12/11/2012	talukder
East Search	6/17/2013	talukder
East Search	6/18/2013	talukder
East Search	6/26/2013	talukder
East Search	6/27/2013	Talukder
East Search	4/22/2014 & 4/30/2014	Talukder
Text Sarched	10/31/2014	Talukder
Assignee Searched	10/13/2015	Talukder
Inventor Searched	10/13/2015	Talukder
East Searched	10/13/2015	Talukder
Assignee Searched	3/9/2016	Talukder
Inventor Searched	3/9/2016	Talukder
East Searched	3/9/2016	Talukder
		Talukder

## INTERFERENCE SEARCH

US Class/ CPC Symbol	US Subclass / CPC Group	Date	Examiner
H04W88/08, H04W72/044, H04W72/042, H04W52/367, H04W52/12, H04W52/40, H04L29/08657, G01S5/0252, G01S5/02, H04B1/3833, H04M1/0247, H04M1/0237		3/16/2016	Talukder
455	All	3/16/2016	Talukder

--	--

## EAST Search History

## EAST Search History (Prior Art)

Ref #	Hits	Search Query	DBs	Default Operator	Plurals	Time Stamp
S1	1	"12896993"	US-PGPUB; USPAT; USOCR; DERWENT; IBM_TDB	OR	ON	2012/12/10 17:09
S2	367	((david near2 astely) (robert near2 baldemair) (dirk near2 gerstenberger) (daniel near2 larsson) (lars near2 lindbom) (stefan near2 parkvall)).in.	US-PGPUB; USPAT; USOCR; DERWENT; IBM_TDB	OR	ON	2012/12/10 19:04
S3	176	S2 and (radio near3 resource)	US-PGPUB; USPAT; USOCR; DERWENT; IBM_TDB	OR	ON	2012/12/10 19:09
S4	28	S2 and (radio near3 resource) and (component with carrier)	US-PGPUB; USPAT; USOCR; DERWENT; IBM_TDB	OR	ON	2012/12/10 19:09
S5	173	(downlink near3 carrier) and (uplink near3 (primary first initial) near3 carrier) and ((second 2nd other next) with (channel resource)) and (control with information)	US-PGPUB; USPAT; USOCR; DERWENT; IBM_TDB	OR	ON	2012/12/11 09:04
S6	137	S5 and (scheduling)	US-PGPUB; USPAT; USOCR; DERWENT; IBM_TDB	OR	ON	2012/12/11 09:04
S7	36	("20120263121"   "20110310856"   "20120127950"   "20110310819"   "20120275395"   "20120287828"   "20120039291"   "20100271970"   "20120307781"   "20110286436"   "20120224535"   "20120140708"   "20110310820"   "20120163288"   "20110299486"   "20100098012"   "20120082125"   "20120294273"   "20110268048"   "20120113910").pn.	US-PGPUB; USPAT; USOCR; DERWENT; IBM_TDB	OR	ON	2012/12/11 09:15
S8	127	(downlink near3 carrier) and (uplink near3 (primary first initial) near3 carrier) and ((second 2nd other next) with (channel resource)) and (carrier adj aggregation)	US-PGPUB; USPAT; USOCR; DERWENT; IBM_TDB	OR	ON	2012/12/11 10:16
S9	2	"20110292887"	US-PGPUB; USPAT; USOCR; DERWENT; IBM_TDB	OR	ON	2012/12/11 11:17

S11	25	((first 1st) adj6 component adj3 carrier) same ((1st first) adj6 (radio resource frame)) and ((2nd second) adj6 component adj3 carrier) same ((2nd second) adj6 (radio resource frame))	US-PGPUB; USPAT; USOCR; DERWENT; IBM_TDB	OR	ON	2012/12/11 11:22
S12	1718	((first 1st) adj6 carrier) same ((1st first) adj6 (radio resource frame)) and ((2nd second) adj6 carrier) same ((2nd second) adj6 (radio resource frame))	US-PGPUB; USPAT; USOCR; DERWENT; IBM_TDB	OR	ON	2012/12/11 11:47
S13	66	(carrier near3 aggregation) and ((first 1st) adj6 carrier) same ((1st first) adj6 (radio resource frame)) and ((2nd second) adj6 carrier) same ((2nd second) adj6 (radio resource frame))	US-PGPUB; USPAT; USOCR; DERWENT; IBM_TDB	OR	ON	2012/12/11 11:47
S14	10842	455/509,522,456.6,137,103,575.ccls.	US-PGPUB; USPAT; USOCR; DERWENT; IBM_TDB	OR	ON	2012/12/11 13:41
S15	28232	370/329,252,331.ccls.	US-PGPUB; USPAT; USOCR; DERWENT; IBM_TDB	OR	ON	2012/12/11 13:41
S16	102	((S14 S15) and (downlink near3 carrier) and (uplink near3 (primary first initial) near3 carrier) and ((second 2nd other next) with (channel resource)) and (control with information)	US-PGPUB; USPAT; USOCR; DERWENT; IBM_TDB	OR	ON	2012/12/11 13:42
S17	1	"13140333"	US-PGPUB; USPAT; USOCR; DERWENT; IBM_TDB	OR	ON	2012/12/11 14:18
S18	2	"20110310856"	US-PGPUB; USPAT; USOCR; DERWENT; IBM_TDB	OR	ON	2012/12/11 14:18
S19	38	((first 1st) adj6 component adj3 carrier) same ((radio resource frame)) and ((2nd second) adj6 component adj3 carrier) same ((2nd second) adj6 (radio resource frame))	US-PGPUB; USPAT; USOCR; DERWENT; IBM_TDB	OR	ON	2012/12/11 14:31
S20	38	((first 1st) adj6 component adj3 carrier) same ((radio resource frame)) and ((2nd second) adj6 component adj3 carrier) same ((2nd second) adj6 (radio resource frame))	US-PGPUB; USPAT; USOCR; DERWENT; IBM_TDB	OR	ON	2012/12/11 14:31
S21	27	((first 1st) adj6 component adj3 carrier) same ((radio resource frame)) and ((2nd second) adj6 component adj3 carrier) same ((2nd second other another) adj4 (radio resource frame))	US-PGPUB; USPAT; USOCR; DERWENT; IBM_TDB	OR	ON	2012/12/11 14:32
S22	38	((first 1st) adj6 component adj3 carrier) same ((radio resource frame)) and ((2nd second) adj6 component adj3 carrier) same ((2nd second other another) adj6 (radio resource frame))	US-PGPUB; USPAT; USOCR; DERWENT; IBM_TDB	OR	ON	2012/12/11 14:32

S23	24	(carrier adj aggregation) and (schemul\$3 near3 (downlink DL) with ((first primary initial) near6 (resource radio frequency frame)))	US-PGPUB; USPAT; USOCR; DERWENT; IBM_TDB	OR	ON	2012/12/11 14:48
S24	8	("7551898"   "7649960"   "7656843"   "7773699").PN.	US-PGPUB; USPAT; USOCR; DERWENT; IBM_TDB	OR	ON	2012/12/11 15:14
S25	2	"20110292900"	US-PGPUB; USPAT; USOCR; DERWENT; IBM_TDB	OR	ON	2012/12/11 15:36
S26	2	"20100271970"	US-PGPUB; USPAT; USOCR; DERWENT; IBM_TDB	OR	ON	2012/12/11 15:37
S27	3	"8050202"	US-PGPUB; USPAT; USOCR; DERWENT; IBM_TDB	OR	ON	2012/12/11 15:38
S28	1	"20120307689"	US-PGPUB; USPAT; USOCR; DERWENT; IBM_TDB	OR	ON	2012/12/11 15:45
S29	2	"8160017"	US-PGPUB; USPAT; USOCR; DERWENT; IBM_TDB	OR	ON	2012/12/11 15:48
S30	2	"20100232373"	US-PGPUB; USPAT; USOCR; DERWENT; IBM_TDB	OR	ON	2012/12/11 15:48
S31	2	"20090016278"	US-PGPUB; USPAT; USOCR; DERWENT; IBM_TDB	OR	ON	2012/12/11 17:16
S32	2	"8265030"	US-PGPUB; USPAT; USOCR; DERWENT; IBM_TDB	OR	ON	2012/12/11 17:19
S33	3	"2008139923"	US-PGPUB; USPAT; USOCR; DERWENT; IBM_TDB	OR	ON	2012/12/11 18:17
S34	14	("20100098012"   "20100232373"   "20110310856"   "20120020317"   "20120082125"   "20120140708"   "8265030").PN.	US-PGPUB; USPAT; USOCR; DERWENT; IBM_TDB	OR	ON	2013/05/29 17:19

S35	7	"455"/\$.ccls. and (carrier adj aggregation) and (schemul\$3 near3 (downlink DL) with ((first primary initial) near6 (resource radio frequency frame)))	US-PGPUB; USPAT; USOCR; DERWENT; IBM_TDB	OR	ON	2013/05/29 17:22
S36	9	"455"/\$.ccls. and (((first 1st) adj6 component adj3 carrier) same ((radio resource frame))) and ((2nd second) adj6 component adj3 carrier) same ((2nd second) adj6 (radio resource frame))	US-PGPUB; USPAT; USOCR; DERWENT; IBM_TDB	OR	ON	2013/05/29 21:37
S38	4	("20070053294"   "20100290405").PN.	US-PGPUB; USPAT; USOCR; DERWENT; IBM_TDB	OR	ON	2013/05/30 12:42
S39	16	("7596114"   "20050013279"   "20030219028"   "20070217406"   "20020105970"   "20060050664"   "20090303938"   "20070064669").PN.	US-PGPUB; USPAT; USOCR; DERWENT; IBM_TDB	OR	ON	2013/05/30 12:42
S40	290	(first 1st) with (component near2 carrier) with down\$1link	US-PGPUB; USPAT; USOCR; DERWENT; IBM_TDB	OR	ON	2013/06/17 10:07
S41	114	(first 1st) with (component near2 carrier) with down\$1link and receiv\$3 near3 control near3 information	US-PGPUB; USPAT; USOCR; DERWENT; IBM_TDB	OR	ON	2013/06/17 10:09
S42	47	(first 1st) near3 (radio adj resource) and (second other another 2nd) near3 (radio adj resource) and component adj carrier	US-PGPUB; USPAT; USOCR; DERWENT; IBM_TDB	OR	ON	2013/06/17 12:29
S43	26	S42 and (carrier adj aggregation) and (schemul\$3 near3 (down\$1link DL reverse\$1link))	US-PGPUB; USPAT; USOCR; DERWENT; IBM_TDB	OR	ON	2013/06/17 12:31
S44	5	(first 1st) near3 (radio adj resource) and (second other another 2nd) near3 (radio adj resource) same (carrier adj aggregation) and (schemul\$3 near3 (down\$1link DL reverse\$1link))	US-PGPUB; USPAT; USOCR; DERWENT; IBM_TDB	OR	ON	2013/06/17 12:46
S45	26	(first 1st) near3 (radio adj resource) and (second other another 2nd) near3 (radio adj resource) and (carrier adj aggregation) and (schemul\$3 near3 (down\$1link DL reverse\$1link))	US-PGPUB; USPAT; USOCR; DERWENT; IBM_TDB	OR	ON	2013/06/17 12:47
S46	31	(second other another 2nd) near3 (radio adj resource) and (carrier adj aggregation) and (schemul\$3 near3 (down\$1link DL reverse\$1link))	US-PGPUB; USPAT; USOCR; DERWENT; IBM_TDB	OR	ON	2013/06/17 12:49
S47	0	@ad<"20091003" and (second other another 2nd) near3 (radio adj resource) and (carrier adj aggregation) and (schemul\$3 near3 (down\$1link DL reverse\$1link))	US-PGPUB; USPAT; USOCR; DERWENT; IBM_TDB	OR	ON	2013/06/17 12:51

S48	0	@ad<"20091003" and (second other another 2nd) near3 (radio adj resource) and (carrier adj component) and (schemul\$3 near3 (down\$link DL reverse\$link))	US-PGPUB; USPAT; USOCR; DERWENT; IBM_TDB	OR	ON	2013/06/17 12:52
S49	1	@ad<"20091003" and (second other another 2nd) near3 (radio adj resource) and (carrier adj component) and ((down\$link DL reverse\$link))	US-PGPUB; USPAT; USOCR; DERWENT; IBM_TDB	OR	ON	2013/06/17 12:53
S50	1	@ad<"20091005" and (second other another 2nd) near3 (radio adj resource) and (carrier adj component) and ((down\$link DL reverse\$link))	US-PGPUB; USPAT; USOCR; DERWENT; IBM_TDB	OR	ON	2013/06/17 12:55
S51	1	@ad<"20091003" and (second other another 2nd) near3 (radio adj resource) and (carrier adj component)	US-PGPUB; USPAT; USOCR; DERWENT; IBM_TDB	OR	ON	2013/06/17 12:56
S52	20	(second other another 2nd) near3 (radio adj resource) and (carrier adj component)	US-PGPUB; USPAT; USOCR; DERWENT; IBM_TDB	OR	ON	2013/06/17 13:31
S53	16	(set near3 radio near3 resource) same component adj carrier	US-PGPUB; USPAT; USOCR; DERWENT; IBM_TDB	OR	ON	2013/06/17 14:14
S54	27	(set near3 ((radio near3 resource) (resource adj block))) same component adj carrier	US-PGPUB; USPAT; USOCR; DERWENT; IBM_TDB	OR	ON	2013/06/17 14:19
S55	755	((radio near3 resource) (resource adj block)) same component adj carrier	US-PGPUB; USPAT; USOCR; DERWENT; IBM_TDB	OR	ON	2013/06/17 14:25
S56	70	((second 2nd other) with ((radio near3 resource) (resource adj block))) same component adj carrier	US-PGPUB; USPAT; USOCR; DERWENT; IBM_TDB	OR	ON	2013/06/17 14:26
S57	327	((radio near3 resource) (resource adj block)) same component adj carrier and (schemul\$3 near3 downlink reverse)	US-PGPUB; USPAT; USOCR; DERWENT; IBM_TDB	OR	ON	2013/06/17 14:27
S58	29	((second 2nd other) with ((radio near3 resource) (resource adj block))) same component adj carrier and (schemul\$3 near3 down\$link reverse\$link)	US-PGPUB; USPAT; USOCR; DERWENT; IBM_TDB	OR	ON	2013/06/17 14:27
S59	24	((second 2nd other) with ((radio near3 resource) (resource adj block))) same component adj carrier same (down\$link reverse\$link)	US-PGPUB; USPAT; USOCR; DERWENT; IBM_TDB	OR	ON	2013/06/17 14:31

S60	10	("20090097447"   "20110081856"   "20090116427"   "20100232373"   "8331307").PN.	US-PGPUB; USPAT; USOCR; DERWENT; IBM_TDB	OR	ON	2013/06/17 14:49
S61	2562	(schedul\$3 near3 downlink) and ((radio adj resource) (resource adj block)) and component	US-PGPUB; USPAT; USOCR; DERWENT; IBM_TDB	OR	ON	2013/06/17 15:16
S62	739	(schedul\$3 near3 downlink) and ((radio adj resource) (resource adj block)) and component adj carrier	US-PGPUB; USPAT; USOCR; DERWENT; IBM_TDB	OR	ON	2013/06/17 15:17
S63	259	(schedul\$3 near3 downlink) same ((radio adj resource) (resource adj block)) and component adj carrier	US-PGPUB; USPAT; USOCR; DERWENT; IBM_TDB	OR	ON	2013/06/17 15:17
S64	39	(schedul\$3 near3 downlink) same ((radio adj resource) (resource adj block)) same (component adj carrier)	US-PGPUB; USPAT; USOCR; DERWENT; IBM_TDB	OR	ON	2013/06/17 15:18
S65	1	@ad<"20091005" and (schedul\$3 near3 downlink) same ((radio adj resource) (resource adj block)) same (component adj carrier)	US-PGPUB; USPAT; USOCR; DERWENT; IBM_TDB	OR	ON	2013/06/17 15:18
S66	1	@ad<"20091005" and (schedul\$3 near3 downlink) same ((radio adj resource) (resource adj block)) same (CC (component adj carrier))	US-PGPUB; USPAT; USOCR; DERWENT; IBM_TDB	OR	ON	2013/06/17 15:20
S67	47	(schedul\$3 near3 downlink) same ((radio adj resource) (resource adj block)) same (CC (component adj carrier))	US-PGPUB; USPAT; USOCR; DERWENT; IBM_TDB	OR	ON	2013/06/17 15:20
S68	356	"455"/\$.cls. and ((radio adj resource) (resource adj block)) same (CC (component adj carrier))	US-PGPUB; USPAT; USOCR; DERWENT; IBM_TDB	OR	ON	2013/06/17 17:10
S70	19	"455"/\$.cls. and (carrier near3 aggregation) and ((first 1st) adj6 carrier) same ((1st first) adj6 (radio resource frame)) and ((2nd second) adj6 carrier) same ((2nd second) adj6 (radio resource frame))	US-PGPUB; USPAT; USOCR; DERWENT; IBM_TDB	OR	ON	2013/06/17 17:17
S71	0	("2013/0107855").URPN.	USPAT	OR	ON	2013/06/18 09:15
S72	0	("2013/0107855").URPN.	US-PGPUB; USPAT	OR	ON	2013/06/18 09:16
S73	408	set near3 (radio frequency) near2 (resource band) same downlink and component	US-PGPUB; USPAT	OR	ON	2013/06/18 09:18
S74	17	set near3 (radio frequency) near2 (resource band) same downlink same (component adj carrier)	US-PGPUB; USPAT	OR	ON	2013/06/18 09:19

S75	19	(set group Cluster) near3 (radio frequency) near2 (resource band) same downlink same (component adj carrier)	US-PGPUB; USPAT	OR	ON	2013/06/18 09:21
S76	12	("8457060"   "20110310819"   "20100271970"   "20130034073"   "20100098012"   "20110310856"   "20110317653"   "20130083742"   "20130083741"   "20120114021"   "20120275395"   "20110317645"   "20110310856").pn.	US-PGPUB; USPAT	OR	ON	2013/06/18 09:31
S77	200	(DL down\$link) with (1st first first primary initia) near3 (set group) near6 (radio resource)	US-PGPUB; USPAT	OR	ON	2013/06/18 10:37
S78	2911	(UL up\$link) with (set group) near6 (radio resource)	US-PGPUB; USPAT	OR	ON	2013/06/18 10:38
S79	110	S77 and S78	US-PGPUB; USPAT	OR	ON	2013/06/18 10:38
S80	3	(DL down\$link) with (1st first first primary initia) near3 (set group) near6 (radio resource) and (DL down\$link) with (set group) near6 (radio resource) with (2nd second other another) near2 component	US-PGPUB; USPAT	OR	ON	2013/06/18 10:47
S81	28	(DL down\$link) with (1st first first primary initia) near3 (set group) near6 (radio resource) and (DL down\$link) with (component near3 carrier)	US-PGPUB; USPAT	OR	ON	2013/06/18 11:17
S82	5	(DL down\$link) with (1st first first primary initia) near3 (set group) near6 (radio resource) and (DL down\$link) with (second 2nd) near3 (component near3 carrier)	US-PGPUB; USPAT	OR	ON	2013/06/18 11:20
S83	4	(1st first first primary initia) near3 (set group) near6 (radio resource) with (DL down\$link) near3 (component near3 carrier)	US-PGPUB; USPAT	OR	ON	2013/06/18 13:50
S84	3	(set group) near6 (radio resource) with (2nd second other another) near6 (DL down\$link) near3 (component near3 carrier)	US-PGPUB; USPAT	OR	ON	2013/06/18 13:52
S85	42	(set group) near6 (radio resource) with (DL down\$link) near3 (component near3 carrier)	US-PGPUB; USPAT	OR	ON	2013/06/18 13:58
S86	30	(set group) near3 ((radio resource)(resource near2 block)) with (DL down\$link) near3 (component near3 carrier)	US-PGPUB; USPAT	OR	ON	2013/06/18 14:07
S87	2	(second 2nd) near3 (down\$1link DL) with ((component near3 carrier) CC) same (set group) with ((radio near2 resource) (resource near2 block))	US-PGPUB; USPAT	OR	ON	2013/06/18 14:14
S88	21	reserv\$3 with component near3 carrier and (second near2 (radio frequency band))	US-PGPUB; USPAT; USOCR; DERWENT; IBM_TDB	OR	ON	2013/06/25 15:31
S89	36	"739528"	US-PGPUB; USPAT; USOCR; DERWENT; IBM_TDB	OR	ON	2013/06/26 09:34
S90	30	"5754138"	US-PGPUB; USPAT; USOCR; DERWENT; IBM_TDB	OR	ON	2013/06/26 09:35



S91	2046	(carrier near3 aggregation) and up\$1link with down\$1link	US-PGPUB; USPAT; USOCR; DERWENT; IBM_TDB	OR	ON	2013/06/26 10:24
S92	1052	(carrier near3 aggregation) and (component near3 carrier) same up\$1link with down\$1link	US-PGPUB; USPAT; USOCR; DERWENT; IBM_TDB	OR	ON	2013/06/26 10:26
S93	110	(carrier near3 aggregation) and (component near3 carrier) same up\$1link with associat\$3 with down\$1link	US-PGPUB; USPAT; USOCR; DERWENT; IBM_TDB	OR	ON	2013/06/26 10:27
S95	17	("370"/\$.ccls "455"/\$.ccls.) and (aggregation) and (CC (component near3 carrier)) same up\$1link with associat\$3 with down\$1link	US-PGPUB; USPAT; USOCR; DERWENT; IBM_TDB	OR	ON	2013/06/26 15:22
S96	67	370/329,341,348,395.4.ccls. and (carrier near3 aggregation) and (component near3 carrier) same up\$1link with associat\$3 with down\$1link	US-PGPUB; USPAT; USOCR; DERWENT; IBM_TDB	OR	ON	2013/06/26 15:26
S97	345368	schedule (DL (down adj link) down\$1link) and (carrier near3 aggregation) and ((UL up\$1link) adj6 associat\$4 near4 (DL down\$1link))	US-PGPUB; USPAT; USOCR; DERWENT; IBM_TDB	OR	ON	2013/06/26 16:45
S98	9	schedule near3 (DL (down adj link) down\$1link) and (carrier near3 aggregation) same((UL up\$1link) adj6 associat\$4 near4 (DL down\$1link))	US-PGPUB; USPAT; USOCR; DERWENT; IBM_TDB	OR	ON	2013/06/26 16:46
S99	35	(schedule allocat\$4) near3 (DL (down adj link) down\$1link) and (carrier near3 aggregation) same((UL up\$1link) adj6 associat\$4 near4 (DL down\$1link))	US-PGPUB; USPAT; USOCR; DERWENT; IBM_TDB	OR	ON	2013/06/26 16:48
S100	0	((1st first) near3 (radio band frequency) with (1st first) near3 (CCcomponent adj carrier))	US-PGPUB; USPAT; USOCR; DERWENT; IBM_TDB	OR	ON	2013/06/26 17:14
S101	216	((1st first) near3 (radio band resource frequency) with (1st first) near3 (CC (component adj carrier)))	US-PGPUB; USPAT; USOCR; DERWENT; IBM_TDB	OR	ON	2013/06/26 17:14
S102	43	((1st first) near3 (radio band resource frequency) with (reserv\$3 schedul\$3 allocat\$3) with (1st first) near3 (CC (component adj carrier)))	US-PGPUB; USPAT; USOCR; DERWENT; IBM_TDB	OR	ON	2013/06/26 17:15
S103	22	("20100142455"   "20120009923"   "20100254329"   "20100091678"   "20110194501"   "20130010619"   "20080310359"   "20060274712"   "20100227569"   "20120208583"	US-PGPUB; USPAT; USOCR; DERWENT; IBM_TDB	OR	ON	2013/06/27 09:57

		"20110267978").PN.				
S104	10	("20100254329"   "20100195624"   "20100023282"   "20090274100"   "20080316957").PN.	US-PGPUB; USPAT; USOCR; DERWENT; IBM_TDB	OR	ON	2013/06/27 10:15
S105	50	("20100322173"   "20110081913"   "20130010721"   "20120140708"   "20100271970"   "20100285809"   "20110007699"   "20130003700"   "20100232373"   "20120051306"   "20120082125"   "20100098012"   "20100003997"   "20100208679"   "20110310856"   "20120082125"   "20120140708"   "20130136084"   "8265030"   "20120020317"   "8265030"   "20110007695"   "20110081932"   "20120314675"   "20110310856"   "20100232373"   "20100296389"   "20120020317"   "20100098012"   "20130034073"   "8447343"   "8472368").PN.	US-PGPUB; USPAT; USOCR; DERWENT; IBM_TDB	OR	ON	2014/04/22 13:25
S106	13348	(H04W88/08, H04W72/044, H04W72/042).cpc.	US-PGPUB; USPAT; USOCR; DERWENT; IBM_TDB	OR	ON	2014/04/22 13:40
S107	4330	(H04W52/367, H04W52/12, H04W52/40).cpc.	US-PGPUB; USPAT; USOCR; DERWENT; IBM_TDB	OR	ON	2014/04/22 13:42
S108	4200	(H04L29/08657, G01S5/0252, G01S5/02).cpc.	US-PGPUB; USPAT; USOCR; DERWENT; IBM_TDB	OR	ON	2014/04/22 13:43
S109	3823	(H04B1/3833, H04M1/0247, H04M1/0237).cpc.	US-PGPUB; USPAT; USOCR; DERWENT; IBM_TDB	OR	ON	2014/04/22 13:44
S110	6130	(H03F3/211, H04B7/0617, H04B7/0669).cpc.	US-PGPUB; USPAT; USOCR; DERWENT; IBM_TDB	OR	ON	2014/04/22 13:44
S111	370	(S106 S107 S108 S109 S110) and (schedul\$4 near3 down\$1link) and (component near3 carrier)	US-PGPUB; USPAT; USOCR; DERWENT; IBM_TDB	OR	ON	2014/04/22 13:45
S112	365	(S106 S107 S108 S109 S110) and (schedul\$4 near3 down\$1link) and (component near3 carrier) and (control with information)	US-PGPUB; USPAT; USOCR; DERWENT; IBM_TDB	OR	ON	2014/04/22 13:46
S113	357	(S106 S107 S108 S109 S110) and (schedul\$4 near3 down\$1link) and (component near carrier) and (control with information)	US-PGPUB; USPAT; USOCR; DERWENT;	OR	ON	2014/04/22 13:47

IPR2022-00648

Apple EX1005 Page 438

			IBM_TDB			
S114	13	(S106 S107 S108 S109 S110) and (DL down\$link) with (1st first first primary initia) near3 (set group) near6 (radio resource) and (DL down\$link) with (component near3 carrier)	US-PGPUB; USPAT; USOCR; DERWENT; IBM_TDB	OR	ON	2014/04/22 13:47
S115	40	(H03F3/211, H04B7/0617, H04B7/0669, H04B1/3833, H04M1/0247, H04M1/0237, H04L29/08657, G01S5/0252, G01S5/02, H04W52/367, H04W52/12, H04W52/40, H04W88/08, H04W72/044, H04W72/042).cpc. and (carrier near3 aggregation) and (component near3 carrier) same up\$1link with associat\$3 with down\$1link	US-PGPUB; USPAT; USOCR; DERWENT; IBM_TDB	OR	ON	2014/04/22 14:17
S116	8750	(H04W88/08, H04W72/044, H04W72/042l).cpc.	US-PGPUB; USPAT; USOCR; DERWENT; IBM_TDB	OR	ON	2014/04/26 14:21
S117	4336	(H04W52/367, H04W52/12, H04W52/40).cpc.	US-PGPUB; USPAT; USOCR; DERWENT; IBM_TDB	OR	ON	2014/04/26 14:22
S118	4205	(H04L29/08657, G01S5/0252, G01S5/02).cpc.	US-PGPUB; USPAT; USOCR; DERWENT; IBM_TDB	OR	ON	2014/04/26 14:23
S119	4144	(H04L29/08657, G01S19/14, G01S5/02).cpc.	US-PGPUB; USPAT; USOCR; DERWENT; IBM_TDB	OR	ON	2014/04/26 14:23
S120	3826	(H04B1/3833, H04M1/0247, H04M1/0237).cpc.	US-PGPUB; USPAT; USOCR; DERWENT; IBM_TDB	OR	ON	2014/04/26 14:24
S121	47	(H04W88/08, H04W72/044, H04W72/042).cpc. and (1st first) near3 (radio band resource frequency) with (1st first) near3 (CC (component adj carrier))	US-PGPUB; USPAT; USOCR; DERWENT; IBM_TDB	OR	ON	2014/04/26 14:27
S122	25	(S116 S117 S118 S119 S120).cpc. and (1st first) near3 (radio band resource frequency) with (1st first) near3 (CC (component adj carrier))	US-PGPUB; USPAT; USOCR; DERWENT; IBM_TDB	OR	ON	2014/04/26 15:35
S123	13432	(H04W88/08, H04W72/044, H04W72/042).cpc.	US-PGPUB; USPAT; USOCR; DERWENT; IBM_TDB	OR	ON	2014/04/30 11:04
S124	4341	(H04W52/367, H04W52/12, H04W52/40).cpc.	US-PGPUB; USPAT; USOCR; DERWENT; IBM_TDB	OR	ON	2014/04/30 11:04
S125	4208	(H04L29/08657, G01S5/0252, G01S5/02).cpc.	US-PGPUB;	OR	ON	2014/04/30

			USPAT; USOCR; DERWENT; IBM_TDB			11:04
S126	3833	(H04B1/3833, H04M1/0247, H04M1/0237).cp.c.	US-PGPUB; USPAT; USOCR; DERWENT; IBM_TDB	OR	ON	2014/04/30 11:04
S127	6154	(H03F3/211, H04B7/0617, H04B7/0669).cp.c.	US-PGPUB; USPAT; USOCR; DERWENT; IBM_TDB	OR	ON	2014/04/30 11:04
S128	98	(S123 S124 S125 S126 S127) and (schedul\$4 near3 down\$1link) and (component near3 carrier) and single with carrier same (plurality multiple several) with (DL down\$1link) with carrier	US-PGPUB; USPAT; USOCR; DERWENT; IBM_TDB	OR	ON	2014/04/30 11:04
S129	52	(S123 S124 S125 S126 S127) and (schedul\$4 near3 down\$1link) and (component near3 carrier) and single near6 carrier same (plurality multiple several) near3 (DL down\$1link) with carrier	US-PGPUB; USPAT; USOCR; DERWENT; IBM_TDB	OR	ON	2014/04/30 11:04
S130	4	(S123 S124 S125 S126 S127) and (schedul\$4) with component near3 carrier and (single near3 (DL down\$1link)) with (first with resource) and (multiple plurality several) near3 (DL downlink) with second with resource	US-PGPUB; USPAT; USOCR; DERWENT; IBM_TDB	OR	ON	2014/04/30 11:37
S131	2	(up\$1link UL) and (schedul\$4) with component near3 carrier same (single near3 (DL down\$1link)) with (first with resource) same (multiple plurality several) near3 (DL downlink) with second with resource	US-PGPUB; USPAT; USOCR; DERWENT; IBM_TDB	OR	ON	2014/04/30 11:40
S132	2	(schedul\$4) with component near3 carrier same (single near3 (DL down\$1link)) with (first with resource) same (multiple plurality several) near3 (DL downlink) with second with resource	US-PGPUB; USPAT; USOCR; DERWENT; IBM_TDB	OR	ON	2014/04/30 11:42
S133	2	(schedul\$4) same (single near3 (DL down\$1link)) with (first with resource) same (multiple plurality several) near3 (DL downlink) with second with resource	US-PGPUB; USPAT; USOCR; DERWENT; IBM_TDB	OR	ON	2014/04/30 11:44
S134	2	(schedul\$4) same (single near3 (DL down\$1link)) with (first with (frequency resource block)) same (multiple plurality several) near3 (DL downlink) with second with (frequency block resource)	US-PGPUB; USPAT; USOCR; DERWENT; IBM_TDB	OR	ON	2014/04/30 11:45
S135	16	(single near3 (DL down\$1link)) with (first with (frequency resource block)) same (multiple plurality several) near3 (DL downlink) with second with (frequency block resource)	US-PGPUB; USPAT; USOCR; DERWENT; IBM_TDB	OR	ON	2014/04/30 11:45
S136	1	allocation with (PUSCH PUCCH UL (up\$1link)) and "20100232373"	US-PGPUB; USPAT; USOCR; DERWENT; IBM_TDB	OR	ON	2014/04/30 14:19
S137	1	allocation and (PUSCH PUCCH UL (up\$1link))	US-PGPUB;	OR	ON	2014/04/30

		and "20100232373"	USPAT; USOCR; DERWENT; IBM_TDB			14:21
S138	2	"20100271970"	US-PGPUB; USPAT; USOCR; DERWENT; IBM_TDB	OR	ON	2014/04/30 14:32
S139	54	("20100322173"   "20110081913"   "20130010721"   "8634358"   "20120140708"   "20100271970"   "20100285809"   "20110007699"   "20130003700"   "20100232373"   "20120051306"   "20120082125"   "20100098012"   "20100003997"   "20100208679"   "20110310856"   "20120082125"   "20120140708"   "20130136084"   "8265030"   "20110243039"   "20120020317"   "8265030"   "20110007695"   "20110081932"   "20120314675"   "20110310856"   "20100232373"   "20100296389"   "20120020317"   "20100098012"   "20130034073"   "8447343"   "8472368").PN.	US-PGPUB; USPAT; USOCR; DERWENT; IBM_TDB	OR	ON	2014/10/15 11:49
S140	15049	(H04W88/08, H04W72/044, H04W72/042).cpc.	US-PGPUB; USPAT; USOCR; DERWENT; IBM_TDB	OR	ON	2014/10/15 13:44
S141	4737	(H04W52/367, H04W52/12, H04W52/40).cpc.	US-PGPUB; USPAT; USOCR; DERWENT; IBM_TDB	OR	ON	2014/10/15 13:44
S142	4341	(H04L29/08657, G01S5/0252, G01S5/02).cpc.	US-PGPUB; USPAT; USOCR; DERWENT; IBM_TDB	OR	ON	2014/10/15 13:44
S143	4030	(H04B1/3833, H04M1/0247, H04M1/0237).cpc.	US-PGPUB; USPAT; USOCR; DERWENT; IBM_TDB	OR	ON	2014/10/15 13:44
S144	6785	(H03F3/211, H04B7/0617, H04B7/0669).cpc.	US-PGPUB; USPAT; USOCR; DERWENT; IBM_TDB	OR	ON	2014/10/15 13:44
S145	96	(S140 S141 S142 S143 S144) and (schedul\$4 near3 down\$1link) and (component near3 carrier) and single with carrier same (plurality multiple several) with (DL down\$1link) with carrier same (frequency resources)	US-PGPUB; USPAT; USOCR; DERWENT; IBM_TDB	OR	ON	2014/10/15 13:44
S146	1	"13315135"	US-PGPUB; USPAT; USOCR; DERWENT; IBM_TDB	OR	ON	2014/10/15 13:54
S147	2	"20080151845"	US-PGPUB;	OR	ON	2014/10/15

			USPAT; USOCR; DERWENT; IBM_TDB			14:58
S148	41	"455"/\$.ccls. and (carrier near3 aggregation) and ((first 1st) adj6 carrier) same ((1st first) adj6 (radio resource frame)) and ((2nd second) adj6 carrier) same ((2nd second) adj6 (radio resource frame))	US-PGPUB; USPAT; USOCR; DERWENT; IBM_TDB	OR	ON	2014/10/15 15:45
S149	3	"455"/451,452.1.ccls. and (carrier near3 aggregation) and ((first 1st) adj6 carrier) same ((1st first) adj6 (radio resource frame)) and ((2nd second) adj6 carrier) same ((2nd second) adj6 (radio resource frame))	US-PGPUB; USPAT; USOCR; DERWENT; IBM_TDB	OR	ON	2014/10/15 18:01
S150	33889	455/451,452.1,509,456.1,522,137,103,575.ccls.	US-PGPUB; USPAT; USOCR; DERWENT; IBM_TDB	OR	ON	2014/10/23 11:25
S151	0	455/451,452.1,509,456.1,522,137,103,575.ccls. and (control\$4) with (resource frequency channel Bin) same (sererv\$4 sav\$4) near3 (other 2nd second another) adj3 (resource frequency channel Bin)	US-PGPUB; USPAT; USOCR; DERWENT; IBM_TDB	OR	ON	2014/10/23 11:32
S152	0	455/451,452.1,509,456.1,522,137,103,575.ccls. and (control\$4) with (resource frequency channel Bin) same (rererv\$4 sav\$4) near3 (other 2nd second another) adj3 (resource frequency channel Bin)	US-PGPUB; USPAT; USOCR; DERWENT; IBM_TDB	OR	ON	2014/10/23 11:33
S153	4	455/451,452.1,509,456.1,522,137,103,575.ccls. and (control\$4) with (resource frequency channel Bin) same (reserv\$4 sav\$4) near3 (other 2nd second another) adj3 (resource frequency channel Bin)	US-PGPUB; USPAT; USOCR; DERWENT; IBM_TDB	OR	ON	2014/10/23 11:34
S154	3	455/451,452.1,509,456.1,522,137,103,575.ccls. and (control\$4) with (resource frequency channel Bin) same (reserv\$4 sav\$4) near3 (other 2nd second another) adj3 (resource frequency channel Bin) and (CC component)	US-PGPUB; USPAT; USOCR; DERWENT; IBM_TDB	OR	ON	2014/10/23 11:37
S155	4	"455"/\$.ccls. and (((first 1st) adj6 component adj3 carrier) same ((radio resource frame))) and ((2nd second) adj6 component adj3 carrier) same ((2nd second other another) adj6 (radio resource frame)) and (reserv\$4 sav\$4 us\$3) near3 (other 2nd second another) adj3 (resource frequency channel Bin) and (CC component)	US-PGPUB; USPAT; USOCR; DERWENT; IBM_TDB	OR	ON	2014/10/23 11:39
S156	15	("20050013279"   "20030219028"   "20070217406"   "20020105970"   "20060050664"   "20090303938"   "20070064669").PN.	US-PGPUB; USPAT; USOCR; DERWENT; IBM_TDB	OR	ON	2014/10/23 12:07
S157	10	"455"/\$.ccls. and (schedul\$3 near3 downlink) same ((radio adj resource) (resource adj block)) same (CC (component adj carrier))	US-PGPUB; USPAT; USOCR; DERWENT; IBM_TDB	OR	ON	2014/10/23 12:07
S158	0	455/451,452.1,509,456.1,522,137,103,575.ccls. and (control\$4) with (resource frequency channel) same (rererv\$4 sav\$4) near3 (other	US-PGPUB; USPAT; USOCR;	OR	ON	2014/10/31 15:22

		2nd second another) adj3 (resource frequency channel Bin)	DERWENT; IBM_TDB			
S161	15374	(H04W88/08, H04W72/044, H04W72/042).cpc.	US-PGPUB; USPAT; USOCR; DERWENT; IBM_TDB	OR	ON	2014/10/31 17:18
S162	4758	(H04W52/367, H04W52/12, H04W52/40).cpc.	US-PGPUB; USPAT; USOCR; DERWENT; IBM_TDB	OR	ON	2014/10/31 17:18
S163	4377	(H04L29/08657, G01S5/0252, G01S5/02).cpc.	US-PGPUB; USPAT; USOCR; DERWENT; IBM_TDB	OR	ON	2014/10/31 17:18
S164	4042	(H04B1/3833, H04M1/0247, H04M1/0237).cpc.	US-PGPUB; USPAT; USOCR; DERWENT; IBM_TDB	OR	ON	2014/10/31 17:18
S165	6867	(H03F3/211, H04B7/0617, H04B7/0669).cpc.	US-PGPUB; USPAT; USOCR; DERWENT; IBM_TDB	OR	ON	2014/10/31 17:18
S167	1	"14170939"	US-PGPUB; USPAT; USOCR; DERWENT; IBM_TDB	OR	ON	2014/11/17 09:46
S168	499	(component near2 carrier) with (primary near2 cell)	US-PGPUB; USPAT; USOCR; DERWENT; IBM_TDB	OR	ON	2014/11/18 14:07
S169	401	"370"/\$.ccls. and (component near2 carrier) with (primary near2 cell)	US-PGPUB; USPAT; USOCR; DERWENT; IBM_TDB	OR	ON	2014/11/18 14:07
S170	378	"370"/\$.ccls. and (component adj2 carrier) with (primary adj2 cell)	US-PGPUB; USPAT; USOCR; DERWENT; IBM_TDB	OR	ON	2014/11/18 14:07
S171	185	"370"/\$.ccls. and (component adj2 carrier) with (primary adj2 cell) with (DL down\$1link)	US-PGPUB; USPAT; USOCR; DERWENT; IBM_TDB	OR	ON	2014/11/18 14:08
S172	4	"370"/\$.ccls. and single near3 (CC (component adj2 carrier)) with (primary adj2 cell) with (DL down\$1link)	US-PGPUB; USPAT; USOCR; DERWENT; IBM_TDB	OR	ON	2014/11/18 14:17
S173	4	single near4 (CC (component adj2 carrier)) with (primary adj2 cell) with (DL down\$1link)	US-PGPUB; USPAT; USOCR;	OR	ON	2014/11/18 14:19

IPR2022-00648

Apple EX1005 Page 443

			DERWENT; IBM_TDB			
S174	287	"370"/\$.ccls. and (CC (component adj2 carrier)) with (primary adj2 cell) with (DL down\$1link)	US-PGPUB; USPAT; USOCR; DERWENT; IBM_TDB	OR	ON	2014/11/18 14:21
S175	1	@ad<"20091004" and "370"/\$.ccls. and (CC (component adj2 carrier)) with (primary adj2 cell) with (DL down\$1link)	US-PGPUB; USPAT; USOCR; DERWENT; IBM_TDB	OR	ON	2014/11/18 14:22
S178	287	"370"/\$.ccls. and (CC (component adj2 carrier)) with (primary adj2 cell) with (DL down\$1link)	US-PGPUB; USPAT; USOCR; DERWENT; IBM_TDB	OR	ON	2014/11/18 14:22
S177	29	("20100322173"   "20110081913"   "20130010721"   "8634358"   "20120140708"   "20100271970"   "20100285809"   "20110007699"   "20130003700"   "20100232373"   "20120051306"   "20120082125"   "20100098012"   "20100003997"   "20100208679"   "20110310856"   "20120082125"   "20120140708"   "20130136084"   "8265030"   "20110243039"   "8792830"   "20120020317"   "8265030"   "20110007695"   "20110081932"   "20120314675"   "20020160784"   "20110310856"   "20100232373"   "20100296389"   "20120020317"   "20100098012"   "20130034073"   "8447343"   "8472368").PN.	US-PGPUB; USPAT	OR	OFF	2015/10/01 11:34
S178	21250	(H04W88/08, H04W72/044, H04W72/042).cpc.	US-PGPUB; USPAT; USOCR; DERWENT; IBM_TDB	OR	ON	2015/10/01 17:24
S179	5857	(H04W52/367, H04W52/12, H04W52/40).cpc.	US-PGPUB; USPAT; USOCR; DERWENT; IBM_TDB	OR	ON	2015/10/01 17:24
S180	5079	(H04L29/08657, G01S5/0252, G01S5/02).cpc.	US-PGPUB; USPAT; USOCR; DERWENT; IBM_TDB	OR	ON	2015/10/01 17:24
S181	4391	(H04B1/3833, H04M1/0247, H04M1/0237).cpc.	US-PGPUB; USPAT; USOCR; DERWENT; IBM_TDB	OR	ON	2015/10/01 17:24
S182	8620	(H03F3/211, H04B7/0617, H04B7/0669).cpc.	US-PGPUB; USPAT; USOCR; DERWENT; IBM_TDB	OR	ON	2015/10/01 17:24
S183	221	(S178 S179 S180 S181 S182) and (schedul\$4 near3 down\$1link) and (component near3	US-PGPUB; USPAT;	OR	ON	2015/10/01 17:24

IPR2022-00648

Apple EX1005 Page 444



		carrier) and single with carrier same (plurality multiple several) with (DL down\$1link) with carrier same (frequency)	USOCR; DERWENT; IBM_TDB			
S184	552	((david near2 astely) (robert near2 baldemair) (dirk near2 gerstenberger) (daniel near2 larsson) (lars near2 lindbom) (stefan near2 parkvall)).in. and ericsson.as.	US-PGPUB; USPAT; USOCR; DERWENT; IBM_TDB	OR	ON	2015/10/01 17:56
S185	1	S183 and S184	US-PGPUB; USPAT; USOCR; DERWENT; IBM_TDB	OR	ON	2015/10/01 17:56
S186	21	455/\$.ccls. and ((first 1st) adj6 component adj3 carrier) same ((1st first) adj6 (radio resource frame)) and ((2nd second) adj6 component adj3 carrier) same ((2nd second) adj6 (radio resource frame))	US-PGPUB; USPAT; USOCR; DERWENT; IBM_TDB	OR	ON	2015/10/01 18:11
S187	24	("20100322173"   "20110081913"   "20130003700"   "20100232373"   "20120051306"   "20120082125"   "20100098012"   "20100003997"   "20100208679"   "20110310856"   "20120082125"   "20120140708"   "20130136084"   "8265030"   "20110243039"   "8792830"   "20120020317"   "8265030"   "20110007695"   "20110081932"   "20120314675"   "20020160784"   "20110310856"   "20100232373"   "20100296389"   "20120020317"   "20100098012"   "20130034073"   "8447343"   "8472368").PN.	US-PGPUB; USPAT	OR	OFF	2015/10/02 12:23
S188	1	"14030298"	US-PGPUB; USPAT	OR	OFF	2015/10/02 15:41
S189	198	((1st first) adj6 (radio resource frame)) and ((2nd second) adj6 component adj3 carrier) same ((2nd second) adj6 (radio resource frame))	US-PGPUB; USPAT; USOCR; DERWENT; IBM_TDB	OR	ON	2015/10/03 16:15
S190	1	"14102508"	US-PGPUB; USPAT; USOCR; DERWENT; IBM_TDB	OR	ON	2015/10/13 14:17
S191	0	"14158378"	US-PGPUB; USPAT; USOCR; DERWENT; IBM_TDB	OR	ON	2015/10/13 14:17
S192	1	"14097736"	US-PGPUB; USPAT; USOCR; DERWENT; IBM_TDB	OR	ON	2015/10/13 14:17
S193	2	"14006545"	US-PGPUB; USPAT; USOCR; DERWENT; IBM_TDB	OR	ON	2015/10/13 14:17
S194	1	"13875620"	US-PGPUB;	OR	ON	2015/10/13

			USPAT; USOCR; DERWENT; IBM_TDB			14:18
S195	1	"13905342"	US-PGPUB; USPAT; USOCR; DERWENT; IBM_TDB	OR	ON	2015/10/13 14:18
S196	1	"13477988"	US-PGPUB; USPAT; USOCR; DERWENT; IBM_TDB	OR	ON	2015/10/13 14:18
S197	2	"13293245"	US-PGPUB; USPAT; USOCR; DERWENT; IBM_TDB	OR	ON	2015/10/13 14:18
S198	1	"13875620"	US-PGPUB; USPAT; USOCR; DERWENT; IBM_TDB	OR	ON	2015/10/13 14:19
S199	2	"13993807"	US-PGPUB; USPAT; USOCR; DERWENT; IBM_TDB	OR	ON	2015/10/13 14:19
S200	1	"13898465"	US-PGPUB; USPAT; USOCR; DERWENT; IBM_TDB	OR	ON	2015/10/13 14:19
S201	1	"13883792"	US-PGPUB; USPAT; USOCR; DERWENT; IBM_TDB	OR	ON	2015/10/13 14:19
S202	1	"13996405"	US-PGPUB; USPAT; USOCR; DERWENT; IBM_TDB	OR	ON	2015/10/13 14:19
S203	1	"13883002"	US-PGPUB; USPAT; USOCR; DERWENT; IBM_TDB	OR	ON	2015/10/13 14:20
S204	0	"14812058"	US-PGPUB; USPAT; USOCR; DERWENT; IBM_TDB	OR	ON	2015/10/13 14:20
S205	7	"8915660"	US-PGPUB; USPAT; USOCR; DERWENT; IBM_TDB	OR	ON	2015/10/13 14:20
S206	1	"13909538"	US-PGPUB;	OR	ON	2015/10/13

IPR2022-00648

Apple EX1005 Page 446

			USPAT; USOCR; DERWENT; IBM_TDB			14:21
S207	1	"13924238"	US-PGPUB; USPAT; USOCR; DERWENT; IBM_TDB	OR	ON	2015/10/13 14:22
S208	1	"13898465"	US-PGPUB; USPAT; USOCR; DERWENT; IBM_TDB	OR	ON	2015/10/13 14:23
S209	2	"13993807"	US-PGPUB; USPAT; USOCR; DERWENT; IBM_TDB	OR	ON	2015/10/13 14:23
S210	58	("20100322173"   "20110081913"   "20130010721"   "8634358"   "20120140708"   "20100271970"   "20100285809"   "20110007699"   "20130003700"   "20100232373"   "20120051306"   "20120082125"   "20100098012"   "20100003997"   "20100208679"   "20110310856"   "20120082125"   "20120140708"   "20130136084"   "8265030"   "20110243039"   "8792830"   "20120020317"   "8265030"   "20110007695"   "20110081932"   "20120314675"   "20020160784"   "20110310856"   "20100232373"   "20100296389"   "20120020317"   "20100098012"   "20130034073"   "8447343"   "8472368").PN.	US-PGPUB; USPAT; USOCR; DERWENT; IBM_TDB	OR	ON	2015/10/13 14:25
S211	1	"13906370"	US-PGPUB; USPAT; USOCR; DERWENT; IBM_TDB	OR	ON	2015/10/13 14:38
S212	58	("20100322173"   "20110081913"   "20130010721"   "8634358"   "20120140708"   "20100271970"   "20100285809"   "20110007699"   "20130003700"   "20100232373"   "20120051306"   "20120082125"   "20100098012"   "20100003997"   "20100208679"   "20110310856"   "20120082125"   "20120140708"   "20130136084"   "8265030"   "20110243039"   "8792830"   "20120020317"   "8265030"   "20110007695"   "20110081932"   "20120314675"   "20020160784"   "20110310856"   "20100232373"   "20100296389"   "20120020317"   "20100098012"   "20130034073"   "8447343"   "8472368").PN.	US-PGPUB; USPAT; USOCR; DERWENT; IBM_TDB	OR	ON	2015/10/13 14:51
S213	0	(H04W88/08, H04W72/044, H04W72/042).cpc. and (H04W52/367, H04W52/12, H04W52/40).cpc. and (H04L29/08657, G01S5/0252, G01S5/02).cpc. and (H04B1/3833, H04M1/0247, H04M1/0237).cpc.	US-PGPUB; USPAT; USOCR; DERWENT; IBM_TDB	OR	ON	2015/10/13 14:55

S214	36289	(H04W88/08, H04W72/044, H04W72/042, H04W52/367, H04W52/12, H04W52/40, H04L29/08657, G01S5/0252, G01S5/02, H04B1/3833, H04M1/0247, H04M1/0237).cpc.	US-PGPUB; USPAT; USOCR; DERWENT; IBM_TDB	OR	ON	2015/10/13 14:56
S215	3	(H04W88/08, H04W72/044, H04W72/042, H04W52/367, H04W52/12, H04W52/40, H04L29/08657, G01S5/0252, G01S5/02, H04B1/3833, H04M1/0247, H04M1/0237).cpc. and single near3 (CC (component adj2 carrier)) with (primary adj2 cell) with (DL down\$1link)	US-PGPUB; USPAT; USOCR; DERWENT; IBM_TDB	OR	ON	2015/10/13 14:56
S216	553	((david near2 astely) (robert near2 baldemair) (dirk near2 gerstenberger) (daniel near2 larsson) (lars near2 lindbom) (stefan near2 parkvall)).in. and ericsson.as.	US-PGPUB; USPAT; USOCR; DERWENT; IBM_TDB	OR	ON	2015/10/13 17:05
S217	553	((david near2 astely) (robert near2 baldemair) (dirk near2 gerstenberger) (daniel near2 larsson) (lars near2 lindbom) (stefan near2 parkvall)).in.) and ericsson.as.	US-PGPUB; USPAT; USOCR; DERWENT; IBM_TDB	OR	ON	2015/10/13 17:05
S218	131	((david near2 astely) (robert near2 baldemair) (dirk near2 gerstenberger) (daniel near2 larsson) (lars near2 lindbom) (stefan near2 parkvall)).in.) and ericsson.as. and carrier adj aggregation	US-PGPUB; USPAT; USOCR; DERWENT; IBM_TDB	OR	ON	2015/10/13 17:07
S219	48	"455"/\$.ccls. and (carrier near3 aggregation) and ((first 1st) adj6 carrier) same ((1st first) adj6 (radio resource frame)) and ((2nd second) adj6 carrier) same ((2nd second) adj6 (radio resource frame)) and carrier adj aggregation	US-PGPUB; USPAT; USOCR; DERWENT; IBM_TDB	OR	ON	2015/10/13 17:27
S220	48	(H04W88/08, H04W72/044, H04W72/042).cpc. and ((first 1st) adj6 component adj3 carrier) same ((1st first) adj6 (radio resource frame)) and ((2nd second) adj6 component adj3 carrier) same ((2nd second) adj6 (radio resource frame))	US-PGPUB; USPAT; USOCR; DERWENT; IBM_TDB	OR	ON	2016/03/09 15:13
S221	15	(set group) near6 (radio resource) with (2nd second other another) near6 (DL down\$1link) near3 (component near3 carrier)	US-PGPUB; USPAT	OR	ON	2016/03/09 15:26
S222	35	455/509,522,456.6,137,103,575.ccls. and (downlink near3 carrier) and (uplink near3 (primary first initial) near3 carrier) and ((second 2nd other next) with (channel resource)) and (carrier adj aggregation)	US-PGPUB; USPAT; USOCR; DERWENT; IBM_TDB	OR	ON	2016/03/09 15:45
S223	0	(H04B1/3833, H04M1/0247, H04M1/0237).cpc. and (((first 1st) adj6 component adj3 carrier) same ((radio resource frame))) and ((2nd second) adj6 component adj3 carrier) same ((2nd second other another) adj4 (radio resource frame))	US-PGPUB; USPAT; USOCR; DERWENT; IBM_TDB	OR	ON	2016/03/09 15:48
S224	0	((david near2 astely) (robert near2 baldemair) (dirk near2 gerstenberger) (daniel near2 larsson) (lars near2 lindbom) (stefan near2 parkvall)).in.) and ericsson.as. and single near3 (CC (component adj2 carrier)) with (primary adj2 cell) with (DL down\$1link)	US-PGPUB; USPAT; USOCR; DERWENT; IBM_TDB	OR	ON	2016/03/09 16:14
S225	32	((david near2 astely) (robert near2 baldemair) (dirk near2 gerstenberger) (daniel near2 larsson) (lars near2 lindbom) (stefan near2	US-PGPUB; USPAT; USOCR;	OR	ON	2016/03/09 16:14

		parkvall).in.) and ericsson.as. and (CC (component adj2 carrier)) with (primary adj2 cell)	DERWENT; IBM_TDB			
S226	130	455/\$.ccls. and (downlink near3 carrier) and (uplink near3 (primary first initial) near3 carrier) and ((second 2nd other next) with (channel resource)) and (control with information)	US-PGPUB; USPAT; USOCR; DERWENT; IBM_TDB	OR	ON	2016/03/09 17:02
S227	30	("20120127950"   "20110310819"   "20120275395"   "20120287828"   "20120039291"   "20100271970"   "20120307781"   "20110286436"   "20120224535"   "20120140708"   "20120163288"   "20110299486"   "20100098012"   "20120082125"   "20120294273").pn.	US-PGPUB; USPAT; USOCR; DERWENT; IBM_TDB	OR	ON	2016/03/09 18:32
S228	10	(carrier adj aggregation) and (schedul\$3 near3 (downlink DL) with ((first primary initial) near6 (resource radio frequency frame))) and ((first 1st) adj6 component adj3 carrier) same ((1st first) adj6 (radio resource frame)) and ((2nd second) adj6 component adj3 carrier) same ((2nd second) adj6 (radio resource frame))	US-PGPUB; USPAT; USOCR; DERWENT; IBM_TDB	OR	ON	2016/03/09 20:46
S229	3	"20070030661"	US-PGPUB; USPAT; USOCR; DERWENT; IBM_TDB	OR	ON	2016/03/09 21:31
S230	76	370/329,252,331.ccls. and (((first 1st) adj6 component adj3 carrier) same ((radio resource frame))) and ((2nd second) adj6 component adj3 carrier) same ((2nd second other another) adj4 (radio resource frame))	US-PGPUB; USPAT; USOCR; DERWENT; IBM_TDB	OR	ON	2016/03/10 09:26
S231	0	(H04B1/3833, H04M1/0247, H04M1/0237).cpc. and (schedul\$3 assign\$3) with (primary adj cell) same2 (multiple several set) near3 component adj2 carrier	US-PGPUB; USPAT; USOCR; DERWENT; IBM_TDB	OR	ON	2016/03/16 11:49
S233	0	(H04B1/3833, H04M1/0247, H04M1/0237).cpc. and (schedul\$3 assign\$3) with (primary adj cell) same2 (multiple several set) near6 carrier	US-PGPUB; USPAT; USOCR; FPRS; EPO; JPO; DERWENT; IBM_TDB	OR	ON	2016/03/16 11:54
S234	18	(H04L5/0053, H04L5/001, H04L5/0094, H04B1/3833, H04M1/0247, H04M1/0237).cpc. and (schedul\$3 assign\$3) with (primary adj cell) same2 (multiple several set) near3 component adj2 carrier	US-PGPUB; USPAT; USOCR; DERWENT; IBM_TDB	OR	ON	2016/03/16 11:59
S235	18	(H04L5/0053, H04L5/001, H04L5/0094, H04B1/3833, H04M1/0247, H04M1/0237).cpc. and (schedul\$3 assign\$3) with (primary adj cell) same2 (multiple several set) near3 component adj2 carrier and (control\$4 adjust\$3) near6 (DL (down\$link))	US-PGPUB; USPAT; USOCR; DERWENT; IBM_TDB	OR	ON	2016/03/16 12:04
S236	7	(H04L5/0053, H04L5/001, H04L5/0094, H04B1/3833, H04M1/0247, H04M1/0237).cpc. and (schedul\$3 assign\$3) with (primary adj cell) same2 (multiple several set) near3	US-PGPUB; USPAT; USOCR; DERWENT;	OR	ON	2016/03/16 12:06

		component adj2 carrier and (control\$4 adjust\$3) near6 (DL (down\$link)) and (second 2nd another other) near3 (radio frequency band resources)	IBM_TDB			
S237	0	455/509,522,456.6,137,103,575.ccls. and (schedul\$3 assign\$3) with (primary adj cell) same2 (multiple several set) near3 component adj2 carrier and (control\$4 adjust\$3) near6 (DL (down\$link)) and (second 2nd another other) near3 (radio frequency band resources)	US-PGPUB; USPAT; USOCR; DERWENT; IBM_TDB	OR	ON	2016/03/16 12:31
S238	7	(A01B12/006, H04L5/0053, H04L5/001, H04L5/0094, H04B1/3833, H04M1/0247, H04M1/0237).cpc. and (schedul\$3 assign\$3) with (primary adj cell) same2 (multiple several set) near3 component adj2 carrier and (control\$4 adjust\$3) near6 (DL (down\$link)) and (second 2nd another other) near3 (radio frequency band resources)	US-PGPUB; USPAT; USOCR; FPRS; EPO; JPO; DERWENT; IBM_TDB	OR	ON	2016/03/16 12:39
S239	4	(H04W88/08, H04W72/044, H04W72/042, H04W52/367, H04W52/12, H04W52/40, H04L 9/08657, G01S5/0252, G01S5/02, H04B1/3833, H04M1/0247, H04M1/0237).cpc. and (schedul\$3 assign\$3) with (primary adj cell) same2 (multiple several set) near3 component adj2 carrier and (control\$4 adjust\$3) near6 (DL (down\$link)) and (second 2nd another other) near3 (radio frequency band resources)	US-PGPUB; USPAT; USOCR; FPRS; EPO; JPO; DERWENT; IBM_TDB	OR	ON	2016/03/16 12:47
S240	0	((david near2 astely) (robert near2 baldemair) (dirk near2 gerstenberger) (daniel near2 larsson) (lars near2 lindbom) (stefan near2 parkvall)).in. and ericsson.as. and (schedul\$3 assign\$3) with (primary adj cell) same2 (multiple several set) near3 component adj2 carrier	US-PGPUB; USPAT; USOCR; FPRS; EPO; JPO; DERWENT; IBM_TDB	OR	ON	2016/03/16 13:28

## EAST Search History (Interference)

Ref #	Hits	Search Query	DBs	Default Operator	Plurals	Time Stamp
S159	0	455/451,452.1,509,456.1,522,137,103,575.ccls. and (control\$4) with (resource frequency channel) same (rererv\$4 sav\$4) near3 (other 2nd second another) adj3 (resource frequency channel Bin)	US-PGPUB; USPAT	OR	ON	2014/10/31 15:24
S160	5	(DL down\$link) with (1st first first primary initia) near3 (set group) near6 (radio resource) and (DL down\$link) with (set group) near6 (radio resource) with (2nd second other another) near2 component	US-PGPUB; USPAT	OR	ON	2014/10/31 15:26
S241	0	(H04B1/3833, H04M1/0247, H04M1/0237).cpc. and (schedul\$3 assign\$3) with (primary adj cell) same2 (multiple several set) near3 component adj2 carrier	US-PGPUB; USPAT	OR	ON	2016/03/16 11:50
S242	7	(H04L5/0053, H04L5/001, H04L5/0094, H04B1/3833, H04M1/0247, H04M1/0237).cpc. and (schedul\$3 assign\$3) with (primary adj cell) same2 (multiple several set) near3 component adj2 carrier and (control\$4 adjust\$3) near6 (DL (down\$link)) and (second 2nd another other) near3 (radio frequency	US-PGPUB; USPAT	OR	ON	2016/03/16 12:38

IPR2022-00648

Apple EX1005 Page 450

		band resources)				
S243	7	(A01B12/006, H04L5/0053, H04L5/001, H04L5/0094, H04B1/3833, H04M1/0247, H04M1/0237).cpc. and (schedul\$3 assign\$3) with (primary adj cell) same2 (multiple several set) near3 component adj2 carrier and (control\$4 adjust\$3) near6 (DL (down\$link)) and (second 2nd another other) near3 (radio frequency band resources)	US-PGPUB; USPAT	OR	ON	2016/03/16 12:39
S244	1	(H04W88/08, H04W72/044, H04W72/042, H04W52/367, H04W52/12, H04W52/40, H04L29/08657, G01S5/0252, G01S5/02, H04B1/3833, H04M1/0247, H04M1/0237).cpc. and (schedul\$3 assign\$3) with (primary adj cell) same2 (multiple several set) near3 component adj2 carrier and (control\$4 adjust\$3) near6 (DL (down\$link)) and (second 2nd another other) near3 (radio frequency band resources)	USPAT	OR	ON	2016/03/16 12:47
S245	4	(H04W88/08, H04W72/044, H04W72/042, H04W52/367, H04W52/12, H04W52/40, H04L29/08657, G01S5/0252, G01S5/02, H04B1/3833, H04M1/0247, H04M1/0237).cpc. and (schedul\$3 assign\$3) with (primary adj cell) same2 (multiple several set) near3 component adj2 carrier and (control\$4 adjust\$3) near6 (DL (down\$link)) and (second 2nd another other) near3 (radio frequency band resources)	US-PGPUB; USPAT	OR	ON	2016/03/16 12:47

3/ 16/ 2016 2:33:25 PM

C:\Users\mtalukder\Documents\EAST\Workspaces\12896993.wsp

**IN THE UNITED STATES PATENT AND TRADEMARK OFFICE**

In re Application of <b>David Astely <i>et al.</i></b>	)	
Serial No.: <b>12/896,993</b>	)	
Filed: <b>October 4, 2010</b>	)	Examiner: Md K. Talukder
For: <b>PUCCH Resource Allocation for Carrier Aggregation for LTE-Advanced</b>	)	Group Art Unit: 2648
Docket No: <b>4015-6942 / P30138-US2</b>	)	Confirmation No.: 1015

**VIA E-MAIL ONLY**

**PROPOSED EXAMINER AMENDMENT**

In response to a telephone conversation with Examiner Talukder on March 9, 2016, Applicant submits the following proposed examiner amendment. The independent claims are amended to include subject matter from dependent claim 7. In view of this proposal, Applicant believes that all pending claims are in condition for allowance and issuance.

Respectfully submitted,

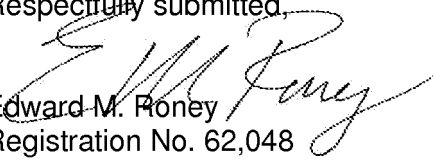
  
Edward M. Roney  
Registration No. 62,048  
Phone: 919.719.4870

Dated: March 14, 2016



**AMENDMENTS TO THE CLAIMS**

1. (Currently amended) A method implemented by a base station of receiving control information from a user terminal, the method comprising:
  - scheduling downlink transmissions to a first user terminal on a single downlink component carrier associated with a primary cell and a second user terminal on multiple downlink component carriers including the single downlink component carrier associated with the primary cell;
  - receiving control information associated with the downlink transmissions to the first user terminal on a first set of radio resources on an uplink component carrier associated with the primary cell, wherein the first set of radio resources is reserved for user terminals scheduled to receive downlink transmissions on the single downlink component carrier associated with the primary cell; **[[and]]**
  - receiving control information associated with the downlink transmissions to the second user terminal on a second set of radio resources on the uplink component carrier associated with the primary cell, wherein the second set of radio resources is reserved for user terminals scheduled to receive downlink transmissions on the multiple downlink component carriers and the second set of resources are additional resources as compared to the first set of resources; **and**  
**transmitting, on the single downlink component carrier, an indication to assign the second set of radio resources when the second user terminal is scheduled to receive the downlink transmissions on the multiple downlink component carriers.**
2. (Previously presented) The method of claim 1 further comprising transmitting control information to the first user terminal on a downlink component carrier to implicitly or explicitly indicate the first set of radio resources on the uplink component carrier associated with the primary cell.
3. (Previously presented) The method of claim 1 further comprising transmitting control information to the second user terminal on a downlink component carrier to implicitly or explicitly indicate the second set radio resources on the uplink component carrier associated with the primary cell.

4. (Original) The method of claim 3 wherein at least one of the first and second sets of radio resources are indicated implicitly by at least one of a downlink control channel index, number of downlink component carriers, and user terminal identifier.
5. (Original) The method of claim 3 wherein at least one of the first and second sets of radio resources are indicated explicitly by an uplink control channel index.
6. (Original) The method of claim 5 wherein the explicit indication is transmitted as radio resource control signaling.
7. (Previously presented) The method of claim 1 further comprising transmitting an acknowledgement resource indication on the single downlink component carrier associated with the primary cell to dynamically assign said second set of radio resources on the uplink component carrier associated with the primary cell to the second user terminal when the second user terminal is scheduled to receive downlink transmissions on the multiple downlink component carriers.
8. (Original) The method of claim 7 wherein the acknowledgement resource indication selects the second set of resources from a semi-static set of uplink resources.

9. (Currently amended) A base station comprising:

a transmitter to transmit user data on one or more downlink component carriers to a first user terminal and a second user terminal; and

a controller to schedule downlink transmissions to the first user terminal and the second user terminal, the controller configured to:

schedule downlink transmissions to the first user terminal on a single downlink component carrier associated with a primary cell and the second user terminal on multiple downlink component carriers including the single downlink component carrier associated with the primary cell;

receive control information associated with the downlink transmissions to the first user terminal on a first set of radio resources on an uplink component carrier associated with the primary cell, wherein the first set of radio resources is reserved for user terminals scheduled to receive downlink transmissions on the single downlink component carrier associated with the primary cell;

[[and]]

receive control information associated with the downlink transmissions to the second user terminal on a second set of radio resources on the uplink component carrier associated with the primary cell, wherein the second set of radio resources is reserved for user terminals scheduled to receive downlink transmissions on the multiple downlink component carriers and the second set of resources are additional resources as compared to the first set of resources; and

transmit, on the single downlink component carrier, an indication to assign the second set of radio resources when the second user terminal is scheduled to receive the downlink transmissions on the multiple downlink component carriers.

10. (Previously presented) The base station of claim 9 wherein the controller is further configured to transmit control information to the first user terminal on a downlink component carrier to implicitly or explicitly indicate the first set of radio resources on the uplink component carrier associated with the primary cell.

11. (Previously presented) The base station of claim 9 wherein the controller is further configured to transmit control information to the second user terminal on a downlink component carrier to implicitly or explicitly indicate the second set of radio resources on the uplink component carrier associated with the primary cell.
12. (Original) The base station of claim 11 wherein the controller is further configured to indicate at least one of the first and second sets of radio resources implicitly by sending at least one of a downlink control channel index, number of downlink component carriers, and user terminal identifier.
13. (Original) The base station of claim 11 wherein the controller is further configured to indicate at least one of the first and second sets of radio resources explicitly by sending an uplink control channel index.
14. (Original) The base station of claim 13 wherein the controller is further configured to send the explicit indication as radio resource control signaling.
15. (Previously presented) The base station of claim 9 wherein the controller is further configured to transmit an acknowledgement resource indication on a downlink component carrier to dynamically assign said second set of radio resources on the uplink component carrier associated with the primary cell to the second user terminal when the second user terminal is scheduled to receive downlink transmissions on the multiple downlink component carriers.
16. (Original) The base station of claim 15 wherein the acknowledgement resource indication selects the second set of resources from a semi-static set of uplink resources.

17. (Currently amended) A method implemented by a user terminal of transmitting control information in a mobile communication network, the method comprising:

receiving an assignment of radio resources for downlink transmissions from a base station;

transmitting, on a first set of radio resources on an uplink component carrier associated with a primary cell, control information associated with the downlink transmissions responsive to receiving an assignment of a single downlink component carrier associated with the primary cell for the downlink transmission, wherein the first set of radio resources is reserved for user terminals scheduled to receive downlink transmissions on the single downlink component carrier associated with the primary cell; **[[and]]**

transmitting, on a second set of radio resources on the uplink component carrier associated with the primary cell, control information associated with the downlink transmissions responsive to receiving an assignment of multiple downlink component carriers including the single downlink component carrier associated with the primary cell for the downlink transmission, wherein the second set of radio resources is reserved for user terminals scheduled to receive downlink transmissions on the multiple downlink component carriers and the second set of resources are additional resources as compared to the first set of resources; **and**

**receiving, on the single downlink component carrier, an indication to assign the second set of radio resources when the user terminal is scheduled to receive the downlink transmissions on the multiple downlink component carriers.**

18. (Previously presented) The method of claim 17 further comprising transmitting user data on the second set of radio resources if a single downlink component carrier associated with a non-primary cell is assigned for the downlink transmission.

19. (Previously presented) The method of claim 17 further comprising receiving control information from the base station on a downlink component carrier implicitly or explicitly indicating the second set of radio resources on the uplink component carrier associated with the primary cell.

20. (Previously presented) The method of claim 19 wherein receiving control information comprises receiving at least one of a downlink control channel index, number of downlink component carriers, and user terminal identifier implicitly identifying said second set of resources.
21. (Original) The method of claim 19 wherein receiving control information comprises receiving an uplink control channel index explicitly identifying said second set of resources.
22. (Original) The method of claim 21 wherein the explicit indication is received as radio resource control signaling.
23. (Previously presented) The method of claim 17, further comprising receiving, from a base station, an acknowledgement resource indication on the single downlink component carrier associated with the primary cell to dynamically assign said second set of radio resources on the uplink component carrier associated with the primary cell when the user terminal is scheduled to receive downlink transmissions on the multiple downlink component carriers.
24. (Original) The method of claim 23 further comprising selecting the second set of resources from a semi-static set of uplink resources responsive to the acknowledgement resource indication.

25. (Currently amended) A user terminal for mobile communications, the user terminal comprising:

- a receiver to receive downlink transmissions from a base station;
- a transmitter to transmit control information associated with the downlink transmission to a base station; and
- a controller to select radio resources for transmission of control information associated with the downlink transmissions, the controller configured to:

- select a first set of radio resources on an uplink component carrier associated with a primary cell responsive to receiving an assignment of a single downlink component carrier associated with the primary cell for the downlink transmission, wherein the first set of radio resources is reserved for user terminals scheduled to receive downlink transmissions on the single downlink component carrier associated with the primary cell; **[[and]]**

- select a second set of radio resources on the uplink component carrier associated with the primary cell responsive to receiving an assignment of multiple downlink component carriers including the single downlink component carrier associated with the primary cell for the downlink transmission, wherein the second set of radio resources is reserved for user terminals scheduled to receive downlink transmissions on the multiple downlink component carriers and the second set of resources are additional resources as compared to the first set of resources; **and**

- receive, on the single downlink component carrier, an indication to assign the second set of radio resources when the user terminal is scheduled to receive the downlink transmissions on the multiple downlink component carriers.**

26. (Previously presented) The user terminal of claim 25 configured to transmit user data on the second set of radio resources if a single downlink component carrier associated with a non-primary cell is assigned for the downlink transmission.

27. (Previously presented) The user terminal of claim 25 wherein the controller is further configured to receive control information from the base station on a downlink component carrier implicitly or explicitly identifying the second set of radio resources on the uplink component carrier associated with the primary cell.

28. (Original) The user terminal of claim 27 wherein the controller is further configured to receive at least one of a downlink control channel index, number of downlink component carriers, and user terminal identifier implicitly identifying the second set of radio resources.

29. (Previously presented) The user terminal of claim 27 wherein the controller is further configured to receive an uplink control channel index explicitly identifying the second set of radio resources on the uplink component carrier associated with the primary cell.

30. (Original) The user terminal of claim 29 wherein the controller is further configured to receive the explicit indication as radio resource control signaling.

31. (Previously presented) The user terminal of claim 25 wherein the controller is further configured to receive, from a base station, an acknowledgement resource indication on a downlink component carrier dynamically assigning said second set of radio resources on the uplink component carrier associated with the primary cell when the user terminal is scheduled to receive downlink transmissions on the multiple downlink component carriers.

32. (Original) The user terminal of claim 31 wherein the controller is configured to select the second set of resources from a semi-static set of uplink resources responsive to the acknowledgement resource indication.



33. (Currently amended) A method implemented by a user terminal in a mobile communication network, the method comprising:

receiving an assignment of radio resources for a downlink transmissions from a base station;

transmitting control information associated with the downlink transmission on a first set of radio resources on an uplink component carrier associated with a primary cell responsive to receiving an assignment of a first downlink component carrier associated with the primary cell for the downlink transmission, wherein the first set of radio resources is reserved for user terminals scheduled to receive downlink transmissions on the first downlink component carrier associated with the primary cell; **[[and]]**

transmitting control information associated with the downlink transmission on a second set of radio resources on the uplink component carrier associated with the primary cell responsive to receiving an assignment of the first downlink component carrier associated with the primary cell and a second ~~single~~ downlink component carrier associated with a non-primary cell for the downlink transmission, wherein the second set of radio resources is reserved for user terminals scheduled to receive downlink transmissions on the first downlink component carrier and the second ~~single~~ downlink component carrier and the second set of resources are additional resources as compared to the first set of resources; **and**

**receiving, on the first downlink component carrier, an indication to assign the second set of radio resources when the user terminal is scheduled to receive the downlink transmissions on the first and second downlink component carriers.**

34. (Currently amended) A user terminal for mobile communications, the user terminal comprising:

- a receiver to receive downlink transmissions from a base station;
- a transmitter to transmit control information associated with the downlink transmission to a base station; and
- a controller to select radio resources for transmission of control information associated with downlink transmissions, the controller configured to:

- select a first set of radio resources on an uplink component carrier associated with a primary cell responsive to receiving an assignment of a first downlink component carrier associated with the primary cell for the downlink transmission, wherein the first set of radio resources is reserved for user terminals scheduled to receive downlink transmissions on the first downlink component carrier associated with the primary cell; **[[and]]**

- select a second set of radio resources on the uplink component carrier associated with the primary cell responsive to receiving an assignment of the first downlink component carrier associated with the primary cell and a second ~~single~~-downlink component carrier associated with a non-primary cell for the downlink transmission, wherein the second set of radio resources is reserved for user terminals scheduled to receive downlink transmissions on the first downlink component carrier and the second ~~single~~-downlink component carrier and the second set of resources are additional resources as compared to the first set of resources; **and**

- receive, on the first downlink component carrier, an indication to assign the second set of radio resources when the user terminal is scheduled to receive the downlink transmissions on the first and second downlink component carriers.**

35. (Previously presented) The method of claim 1, further comprising:

- receiving user data on the second set of radio resources if a single downlink component carrier associated with a non-primary cell is assigned for the downlink transmission.

36. (Previously presented) The method of claim 1, further comprising:  
receiving control signaling on the second set of radio resources if a single downlink component carrier associated with a non-primary cell is assigned for the downlink transmission.
37. (Previously presented) The base station of claim 9, further configured to:  
receive user data on the second set of radio resources if a single downlink component carrier associated with a non-primary cell is assigned for the downlink transmission.
38. (Previously presented) The base station of claim 9, further configured to:  
receive control signaling on the second set of radio resources if a single downlink component carrier associated with a non-primary cell is assigned for the downlink transmission.
39. (Previously presented) The method of claim 17, further comprising:  
transmitting control signaling on the second set of radio resources if a single downlink component carrier associated with a non-primary cell is assigned for the downlink transmission.
40. (Previously presented) The user terminal of claim 25, further configured to:  
transmit control signaling on the second set of radio resources if a single downlink component carrier associated with a non-primary cell is assigned for the downlink transmission.
41. (Previously presented) The method of claim 1, further comprising:  
if the first user terminal is scheduled to receive downlink transmissions on a second single downlink component carrier associated with a non-primary cell, receiving control information associated with the downlink transmissions to the first user terminal on the second set of radio resources on the uplink component carrier associated with the primary cell, wherein the second set of radio resources is reserved for user terminals scheduled to receive downlink transmissions on the second single downlink component carrier.

42. (Previously presented) The base station of claim 9, further configured to:

if the first user terminal is scheduled to receive downlink transmissions on a second single downlink component carrier associated with a non-primary cell, receive control information associated with the downlink transmissions to the first user terminal on the second set of radio resources on the uplink component carrier associated with the primary cell, wherein the second set of radio resources is reserved for user terminals scheduled to receive downlink transmissions on the second single downlink component carrier.

43. (Currently amended) A method implemented by a base station of receiving control information from a first user terminal and a second user terminal, the method comprising:

- scheduling downlink transmissions to the first user terminal on a single downlink component carrier associated with a primary cell and the second user terminal on multiple downlink component carriers including the single downlink component carrier associated with the primary cell; and
- receiving on a first set or a second set of resources on an uplink component carrier associated with a primary cell, including:
  - receiving control information associated with the downlink transmissions to the first user terminal on the first set of radio resources on the uplink component carrier associated with the primary cell, wherein the first set of radio resources is reserved for user terminals scheduled to receive downlink transmissions on the single downlink component carrier associated with the primary cell; **[[and]]**
  - receiving control information associated with the downlink transmissions to the second user terminal on the second set of radio resources on the uplink component carrier associated with the primary cell, wherein the second set of radio resources is reserved for user terminals scheduled to receive downlink transmissions on the multiple downlink component carriers and the second set of resources are additional resources as compared to the first set of resources; **and**

**transmitting, on the single downlink component carrier, an indication to assign the second set of radio resources when the second user terminal is scheduled to receive the downlink transmissions on the multiple downlink component carriers.**

44. (Currently amended) A base station comprising:

a transmitter to transmit user data on one or more downlink component carriers to a first user terminal and a second user terminal; and

a controller to schedule downlink transmissions to the first user terminal and the second user terminal, the controller configured to:

schedule downlink transmissions to the first user terminal on a single downlink component carrier associated with the primary cell and the second user terminal on multiple downlink component carriers including the single downlink component carrier associated with the primary cell; and

receiving on a first set or a second set of resources on an uplink component carrier associated with a primary cell, including:

receive control information associated with the downlink transmissions to the first user terminal on the first set of radio resources on the uplink component carrier associated with the primary cell, wherein the first set of radio resources is reserved for user terminals scheduled to receive downlink transmissions on the single downlink component carrier associated with the primary cell; **[[and]]**

receive control information associated with the downlink transmissions to the second user terminal on the second set of radio resources on the uplink component carrier associated with the primary cell, wherein the second set of radio resources is reserved for user terminals scheduled to receive downlink transmissions on the multiple downlink component carriers and the second set of resources are additional resources as compared to the first set of resources; **and**

**transmit, on the single downlink component carrier, an indication to assign the second set of radio resources when the second user terminal is scheduled to receive the downlink transmissions on the multiple downlink component carriers.**

45. (Previously presented) The method of claim 1, wherein the first user equipment is the same as the second user equipment.

46. (Previously presented) The method of claim 1, wherein the first user equipment is different from the second user equipment.

47. (Previously presented) The base station of claim 9, wherein the first user equipment is the same as the second user equipment.

48. (Previously presented) The base station of claim 9, wherein the first user equipment is different from the second user equipment.

49. (Previously presented) The method of claim 43, wherein the first user equipment is the same as the second user equipment.

50. (Previously presented) The method of claim 43, wherein the first user equipment is different from the second user equipment.

51. (Previously presented) The base station of claim 44, wherein the first user equipment is the same as the second user equipment.

52. (Previously presented) The base station of claim 44, wherein the first user equipment is different from the second user equipment.

Doc code: IDS

PTO/SB/08a (03-15)

Doc description: Information Disclosure Statement (IDS) Filed

Approved for use through 07/31/2016. OMB 0651-0031

U.S. Patent and Trademark Office; U.S. DEPARTMENT OF COMMERCE

Under the Paperwork Reduction Act of 1995, no persons are required to respond to a collection of information unless it contains a valid OMB control number.

<b>INFORMATION DISCLOSURE STATEMENT BY APPLICANT</b> ( Not for submission under 37 CFR 1.99)	Application Number	12896993
	Filing Date	2010-10-04
	First Named Inventor	David Astely et al.
	Art Unit	2648
	Examiner Name	Md K. Talukder
	Attorney Docket Number	4015-6942 / P30138-US2

U.S.PATENTS							Remove
Examiner Initial*	Cite No	Patent Number	Kind Code <sup>1</sup>	Issue Date	Name of Patentee or Applicant of cited Document	Pages,Columns,Lines where Relevant Passages or Relevant Figures Appear	
	1						

If you wish to add additional U.S. Patent citation information please click the Add button.

Add

U.S.PATENT APPLICATION PUBLICATIONS							Remove
Examiner Initial*	Cite No	Publication Number	Kind Code <sup>1</sup>	Publication Date	Name of Patentee or Applicant of cited Document	Pages,Columns,Lines where Relevant Passages or Relevant Figures Appear	
	1						

If you wish to add additional U.S. Published Application citation information please click the Add button.

Add

FOREIGN PATENT DOCUMENTS								Remove
Examiner Initial*	Cite No	Foreign Document Number <sup>3</sup>	Country Code <sup>2</sup> i	Kind Code <sup>4</sup>	Publication Date	Name of Patentee or Applicant of cited Document	Pages,Columns,Lines where Relevant Passages or Relevant Figures Appear	T <sup>5</sup>
	1							

If you wish to add additional Foreign Patent Document citation information please click the Add button

Add

NON-PATENT LITERATURE DOCUMENTS							Remove
Examiner Initials*	Cite No	Include name of the author (in CAPITAL LETTERS), title of the article (when appropriate), title of the item (book, magazine, journal, serial, symposium, catalog, etc), date, pages(s), volume-issue number(s), publisher, city and/or country where published.					T <sup>5</sup>



**INFORMATION DISCLOSURE  
STATEMENT BY APPLICANT**  
( Not for submission under 37 CFR 1.99)

Application Number		12896993
Filing Date		2010-10-04
First Named Inventor	David Astely et al.	
Art Unit	2648	
Examiner Name	Md K. Talukder	
Attorney Docket Number	4015-6942 / P30138-US2	

1	NTT DOCOMO, Inc., "UL Layered Control Signal Structure in LTE-Advanced", 3GPP DRAFT RAN WG1 Meeting #54bis; RI-083679 UL LAYERED CONTROL SIGNAL, 3RD GENERATION PARTNERSHIP PROJECT (3GPP), MOBILE COMPETENCE CENTRE ; 650, ROUTE DES LUCIOLES ; F-06921 SOPHIA-ANTIPOLIS CEDEX ; FRANCE, vol. Ran WG1, no. Prague, Czech Republic; 20080929-20081003, 29 September 2008 (2008-09-29), KP050597042, [retrieved on 2008-09-24]
---	---

If you wish to add additional non-patent literature document citation information please click the Add button

**EXAMINER SIGNATURE**

Examiner Signature	/Md Talukder/	Date Considered	03/16/2016
--------------------	---------------	-----------------	------------

\*EXAMINER: Initial if reference considered, whether or not citation is in conformance with MPEP 609. Draw line through a citation if not in conformance and not considered. Include copy of this form with next communication to applicant.

<sup>1</sup> See Kind Codes of USPTO Patent Documents at [www.USPTO.GOV](http://www.USPTO.GOV) or MPEP 901.04. <sup>2</sup> Enter office that issued the document, by the two-letter code (WIPO Standard ST.3). <sup>3</sup> For Japanese patent documents, the indication of the year of the reign of the Emperor must precede the serial number of the patent document. <sup>4</sup> Kind of document by the appropriate symbols as indicated on the document under WIPO Standard ST.16 if possible. <sup>5</sup> Applicant is to place a check mark here if English language translation is attached.

**INFORMATION DISCLOSURE  
STATEMENT BY APPLICANT**  
( Not for submission under 37 CFR 1.99)

Application Number		12896993	
Filing Date		2010-10-04	
First Named Inventor	David Astely et al.		
Art Unit	2648		
Examiner Name	Md K. Talukder		
Attorney Docket Number	4015-6942 / P30138-US2		

**CERTIFICATION STATEMENT**

Please see 37 CFR 1.97 and 1.98 to make the appropriate selection(s):

That each item of information contained in the information disclosure statement was first cited in any communication from a foreign patent office in a counterpart foreign application not more than three months prior to the filing of the information disclosure statement. See 37 CFR 1.97(e)(1).

**OR**

That no item of information contained in the information disclosure statement was cited in a communication from a foreign patent office in a counterpart foreign application, and, to the knowledge of the person signing the certification after making reasonable inquiry, no item of information contained in the information disclosure statement was known to any individual designated in 37 CFR 1.56(c) more than three months prior to the filing of the information disclosure statement. See 37 CFR 1.97(e)(2).

See attached certification statement.

The fee set forth in 37 CFR 1.17 (p) has been submitted herewith.

A certification statement is not submitted herewith.

**SIGNATURE**

A signature of the applicant or representative is required in accordance with CFR 1.33, 10.18. Please see CFR 1.4(d) for the form of the signature.

Signature	/Edward M. Roney, Reg. No. 62048/	Date (YYYY-MM-DD)	2016-02-12
Name/Print	Edward M. Roney	Registration Number	62048

This collection of information is required by 37 CFR 1.97 and 1.98. The information is required to obtain or retain a benefit by the public which is to file (and by the USPTO to process) an application. Confidentiality is governed by 35 U.S.C. 122 and 37 CFR 1.14. This collection is estimated to take 1 hour to complete, including gathering, preparing and submitting the completed application form to the USPTO. Time will vary depending upon the individual case. Any comments on the amount of time you require to complete this form and/or suggestions for reducing this burden, should be sent to the Chief Information Officer, U.S. Patent and Trademark Office, U.S. Department of Commerce, P.O. Box 1450, Alexandria, VA 22313-1450. **DO NOT SEND FEES OR COMPLETED FORMS TO THIS ADDRESS. SEND TO: Commissioner for Patents, P.O. Box 1450, Alexandria, VA 22313-1450.**

## Privacy Act Statement

The Privacy Act of 1974 (P.L. 93-579) requires that you be given certain information in connection with your submission of the attached form related to a patent application or patent. Accordingly, pursuant to the requirements of the Act, please be advised that: (1) the general authority for the collection of this information is 35 U.S.C. 2(b)(2); (2) furnishing of the information solicited is voluntary; and (3) the principal purpose for which the information is used by the U.S. Patent and Trademark Office is to process and/or examine your submission related to a patent application or patent. If you do not furnish the requested information, the U.S. Patent and Trademark Office may not be able to process and/or examine your submission, which may result in termination of proceedings or abandonment of the application or expiration of the patent.

The information provided by you in this form will be subject to the following routine uses:

1. The information on this form will be treated confidentially to the extent allowed under the Freedom of Information Act (5 U.S.C. 552) and the Privacy Act (5 U.S.C. 552a). Records from this system of records may be disclosed to the Department of Justice to determine whether the Freedom of Information Act requires disclosure of these records.
2. A record from this system of records may be disclosed, as a routine use, in the course of presenting evidence to a court, magistrate, or administrative tribunal, including disclosures to opposing counsel in the course of settlement negotiations.
3. A record in this system of records may be disclosed, as a routine use, to a Member of Congress submitting a request involving an individual, to whom the record pertains, when the individual has requested assistance from the Member with respect to the subject matter of the record.
4. A record in this system of records may be disclosed, as a routine use, to a contractor of the Agency having need for the information in order to perform a contract. Recipients of information shall be required to comply with the requirements of the Privacy Act of 1974, as amended, pursuant to 5 U.S.C. 552a(m).
5. A record related to an International Application filed under the Patent Cooperation Treaty in this system of records may be disclosed, as a routine use, to the International Bureau of the World Intellectual Property Organization, pursuant to the Patent Cooperation Treaty.
6. A record in this system of records may be disclosed, as a routine use, to another federal agency for purposes of National Security review (35 U.S.C. 181) and for review pursuant to the Atomic Energy Act (42 U.S.C. 218(c)).
7. A record from this system of records may be disclosed, as a routine use, to the Administrator, General Services, or his/her designee, during an inspection of records conducted by GSA as part of that agency's responsibility to recommend improvements in records management practices and programs, under authority of 44 U.S.C. 2904 and 2906. Such disclosure shall be made in accordance with the GSA regulations governing inspection of records for this purpose, and any other relevant (i.e., GSA or Commerce) directive. Such disclosure shall not be used to make determinations about individuals.
8. A record from this system of records may be disclosed, as a routine use, to the public after either publication of the application pursuant to 35 U.S.C. 122(b) or issuance of a patent pursuant to 35 U.S.C. 151. Further, a record may be disclosed, subject to the limitations of 37 CFR 1.14, as a routine use, to the public if the record was filed in an application which became abandoned or in which the proceedings were terminated and which application is referenced by either a published application, an application open to public inspections or an issued patent.
9. A record from this system of records may be disclosed, as a routine use, to a Federal, State, or local law enforcement agency, if the USPTO becomes aware of a violation or potential violation of law or regulation.

Under the Paperwork Reduction Act of 1995, no persons are required to respond to a collection of information unless it contains a valid OMB control number.

### REQUEST FOR CONTINUED EXAMINATION(RCE)TRANSMITTAL (Submitted Only via EFS-Web)

Application Number	12896993	Filing Date	2010-10-04	Docket Number (if applicable)	4015-6942 / p30138-us2	Art Unit	2648
First Named Inventor	David Astely et al.			Examiner Name	Md. K. Talukder		

**This is a Request for Continued Examination (RCE) under 37 CFR 1.114 of the above-identified application.**  
Request for Continued Examination (RCE) practice under 37 CFR 1.114 does not apply to any utility or plant application filed prior to June 8, 1995, or to any design application. The Instruction Sheet for this form is located at WWW.USPTO.GOV

#### SUBMISSION REQUIRED UNDER 37 CFR 1.114

Note: If the RCE is proper, any previously filed unentered amendments and amendments enclosed with the RCE will be entered in the order in which they were filed unless applicant instructs otherwise. If applicant does not wish to have any previously filed unentered amendment(s) entered, applicant must request non-entry of such amendment(s).

Previously submitted. If a final Office action is outstanding, any amendments filed after the final Office action may be considered as a submission even if this box is not checked.

Consider the arguments in the Appeal Brief or Reply Brief previously filed on \_\_\_\_\_

Other \_\_\_\_\_

Enclosed

Amendment/Reply

Information Disclosure Statement (IDS)

Affidavit(s)/ Declaration(s)

Other \_\_\_\_\_

#### MISCELLANEOUS

Suspension of action on the above-identified application is requested under 37 CFR 1.103(c) for a period of months \_\_\_\_\_  
(Period of suspension shall not exceed 3 months; Fee under 37 CFR 1.17(i) required)

Other \_\_\_\_\_

#### FEES

**The RCE fee under 37 CFR 1.17(e) is required by 37 CFR 1.114 when the RCE is filed.**

The Director is hereby authorized to charge any underpayment of fees, or credit any overpayments, to Deposit Account No 181167

#### SIGNATURE OF APPLICANT, ATTORNEY, OR AGENT REQUIRED

Patent Practitioner Signature  
Applicant Signature

Signature of Registered U.S. Patent Practitioner			
Signature	Edward M. Roney/	Date (YYYY-MM-DD)	2016-06-20
Name	Edward M. Roney	Registration Number	62048

This collection of information is required by 37 CFR 1.114. The information is required to obtain or retain a benefit by the public which is to file (and by the USPTO to process) an application. Confidentiality is governed by 35 U.S.C. 122 and 37 CFR 1.11 and 1.14. This collection is estimated to take 12 minutes to complete, including gathering, preparing, and submitting the completed application form to the USPTO. Time will vary depending upon the individual case. Any comments on the amount of time you require to complete this form and/or suggestions for reducing this burden, should be sent to the Chief Information Officer, U.S. Patent and Trademark Office, U.S. Department of Commerce, P.O. Box 1450, Alexandria, VA 22313-1450.

*If you need assistance in completing the form, call 1-800-PTO-9199 and select option 2.*

## Privacy Act Statement

The Privacy Act of 1974 (P.L. 93-579) requires that you be given certain information in connection with your submission of the attached form related to a patent application or patent. Accordingly, pursuant to the requirements of the Act, please be advised that: (1) the general authority for the collection of this information is 35 U.S.C. 2(b)(2); (2) furnishing of the information solicited is voluntary; and (3) the principal purpose for which the information is used by the U.S. Patent and Trademark Office is to process and/or examine your submission related to a patent application or patent. If you do not furnish the requested information, the U.S. Patent and Trademark Office may not be able to process and/or examine your submission, which may result in termination of proceedings or abandonment of the application or expiration of the patent.

The information provided by you in this form will be subject to the following routine uses:

1. The information on this form will be treated confidentially to the extent allowed under the Freedom of Information Act (5 U.S.C. 552) and the Privacy Act (5 U.S.C. 552a). Records from this system of records may be disclosed to the Department of Justice to determine whether the Freedom of Information Act requires disclosure of these records.
2. A record from this system of records may be disclosed, as a routine use, in the course of presenting evidence to a court, magistrate, or administrative tribunal, including disclosures to opposing counsel in the course of settlement negotiations.
3. A record in this system of records may be disclosed, as a routine use, to a Member of Congress submitting a request involving an individual, to whom the record pertains, when the individual has requested assistance from the Member with respect to the subject matter of the record.
4. A record in this system of records may be disclosed, as a routine use, to a contractor of the Agency having need for the information in order to perform a contract. Recipients of information shall be required to comply with the requirements of the Privacy Act of 1974, as amended, pursuant to 5 U.S.C. 552a(m).
5. A record related to an International Application filed under the Patent Cooperation Treaty in this system of records may be disclosed, as a routine use, to the International Bureau of the World Intellectual Property Organization, pursuant to the Patent Cooperation Treaty.
6. A record in this system of records may be disclosed, as a routine use, to another federal agency for purposes of National Security review (35 U.S.C. 181) and for review pursuant to the Atomic Energy Act (42 U.S.C. 218(c)).
7. A record from this system of records may be disclosed, as a routine use, to the Administrator, General Services, or his/her designee, during an inspection of records conducted by GSA as part of that agency's responsibility to recommend improvements in records management practices and programs, under authority of 44 U.S.C. 2904 and 2906. Such disclosure shall be made in accordance with the GSA regulations governing inspection of records for this purpose, and any other relevant (i.e., GSA or Commerce) directive. Such disclosure shall not be used to make determinations about individuals.
8. A record from this system of records may be disclosed, as a routine use, to the public after either publication of the application pursuant to 35 U.S.C. 122(b) or issuance of a patent pursuant to 35 U.S.C. 151. Further, a record may be disclosed, subject to the limitations of 37 CFR 1.14, as a routine use, to the public if the record was filed in an application which became abandoned or in which the proceedings were terminated and which application is referenced by either a published application, an application open to public inspections or an issued patent.
9. A record from this system of records may be disclosed, as a routine use, to a Federal, State, or local law enforcement agency, if the USPTO becomes aware of a violation or potential violation of law or regulation.

IN THE UNITED STATES PATENT AND TRADEMARK OFFICE

In re Application of <b>David Astely et al.</b>	)	
	)	
Serial No.: <b>12/896,993</b>	)	Examiner: Md K. Talukder
	)	
Filed: <b>October 4, 2010</b>	)	Group Art Unit: 2648
	)	
For: <b>PUCCH Resource Allocation for Carrier Aggregation for LTE-Advanced</b>	)	Confirmation No.: 1015
	)	
Docket No: <b>4015-6942 / P30138-US2</b>	)	
	)	

Mail Stop RCE  
Commissioner for Patents  
P.O. Box 1450  
Alexandria, VA 22313-1450

**AMENDMENTS AND REQUEST FOR CONTINUED EXAMINATION**

This paper is being filed prior to the payment of the issue fee to re-open prosecution in this matter based on amendments to the claims described herein and a separately-filed information disclosure statement (IDS). Reconsideration is respectfully requested in light of the amendments and/or remarks below, and with an express Request for Continued Examination (RCE) under 37 C.F.R. § 1.114. The Office is hereby authorized to charge any fees required for entry of this paper to Deposit Account 18-1167.

### AMENDMENTS TO THE CLAIMS

1. (Currently amended) A method implemented by a base station of receiving control information from a user terminal, the method comprising:
  - scheduling downlink transmissions to a first user terminal on a single downlink component carrier associated with a primary cell and a second user terminal on multiple downlink component carriers including the single downlink component carrier associated with the primary cell;
  - receiving control information associated with the downlink transmissions to the first user terminal on a first set of radio resources on an uplink component carrier associated with the primary cell, wherein the first set of radio resources is reserved for user terminals scheduled to receive downlink transmissions on the single downlink component carrier associated with the primary cell;
  - receiving control information associated with the downlink transmissions to the second user terminal on a second set of radio resources on the uplink component carrier associated with the primary cell, wherein the second set of radio resources is reserved for user terminals scheduled to receive downlink transmissions on the multiple downlink component carriers and the second set of resources are additional resources as compared to the first set of resources; and
  - transmitting, on the single downlink component carrier, an indication to assign **radio resources in** the second set of radio resources when the second user terminal is scheduled to receive the downlink transmissions on the multiple downlink component carriers.
  
2. (Previously presented) The method of claim 1 further comprising transmitting control information to the first user terminal on a downlink component carrier to implicitly or explicitly indicate the first set of radio resources on the uplink component carrier associated with the primary cell.
  
3. (Previously presented) The method of claim 1 further comprising transmitting control information to the second user terminal on a downlink component carrier to implicitly or explicitly indicate the second set radio resources on the uplink component carrier associated with the primary cell.



4. (Original) The method of claim 3 wherein at least one of the first and second sets of radio resources are indicated implicitly by at least one of a downlink control channel index, number of downlink component carriers, and user terminal identifier.
5. (Original) The method of claim 3 wherein at least one of the first and second sets of radio resources are indicated explicitly by an uplink control channel index.
6. (Original) The method of claim 5 wherein the explicit indication is transmitted as radio resource control signaling.
7. (Currently amended) The method of claim 1 further comprising transmitting an acknowledgement resource indication on the single downlink component carrier associated with the primary cell to dynamically assign radio resources in said second set of radio resources on the uplink component carrier associated with the primary cell to the second user terminal when the second user terminal is scheduled to receive downlink transmissions on the multiple downlink component carriers.
8. (Original) The method of claim 7 wherein the acknowledgement resource indication selects the second set of resources from a semi-static set of uplink resources.

9. (Currently amended) A base station comprising:

a transmitter to transmit user data on one or more downlink component carriers to a first user terminal and a second user terminal; and

a controller to schedule downlink transmissions to the first user terminal and the second user terminal, the controller configured to:

schedule downlink transmissions to the first user terminal on a single downlink component carrier associated with a primary cell and the second user terminal on multiple downlink component carriers including the single downlink component carrier associated with the primary cell;

receive control information associated with the downlink transmissions to the first user terminal on a first set of radio resources on an uplink component carrier associated with the primary cell, wherein the first set of radio resources is reserved for user terminals scheduled to receive downlink transmissions on the single downlink component carrier associated with the primary cell;

receive control information associated with the downlink transmissions to the second user terminal on a second set of radio resources on the uplink component carrier associated with the primary cell, wherein the second set of radio resources is reserved for user terminals scheduled to receive downlink transmissions on the multiple downlink component carriers and the second set of resources are additional resources as compared to the first set of resources; and

transmit, on the single downlink component carrier, an indication to assign radio resources in the second set of radio resources when the second user terminal is scheduled to receive the downlink transmissions on the multiple downlink component carriers.

10. (Previously presented) The base station of claim 9 wherein the controller is further configured to transmit control information to the first user terminal on a downlink component carrier to implicitly or explicitly indicate the first set of radio resources on the uplink component carrier associated with the primary cell.

11. (Previously presented) The base station of claim 9 wherein the controller is further configured to transmit control information to the second user terminal on a downlink component carrier to implicitly or explicitly indicate the second set of radio resources on the uplink component carrier associated with the primary cell.
12. (Original) The base station of claim 11 wherein the controller is further configured to indicate at least one of the first and second sets of radio resources implicitly by sending at least one of a downlink control channel index, number of downlink component carriers, and user terminal identifier.
13. (Original) The base station of claim 11 wherein the controller is further configured to indicate at least one of the first and second sets of radio resources explicitly by sending an uplink control channel index.
14. (Original) The base station of claim 13 wherein the controller is further configured to send the explicit indication as radio resource control signaling.
15. (Currently amended) The base station of claim 9 wherein the controller is further configured to transmit an acknowledgement resource indication on a downlink component carrier to dynamically assign radio resources in said second set of radio resources on the uplink component carrier associated with the primary cell to the second user terminal when the second user terminal is scheduled to receive downlink transmissions on the multiple downlink component carriers.
16. (Original) The base station of claim 15 wherein the acknowledgement resource indication selects the second set of resources from a semi-static set of uplink resources.

17. (Currently amended) A method implemented by a user terminal of transmitting control information in a mobile communication network, the method comprising:

receiving an assignment of radio resources for downlink transmissions from a base station;

transmitting, on a first set of radio resources on an uplink component carrier associated with a primary cell, control information associated with the downlink transmissions responsive to receiving an assignment of radio resources on a single downlink component carrier associated with the primary cell for the downlink transmissions, wherein the first set of radio resources is reserved for user terminals scheduled to receive downlink transmissions on the single downlink component carrier associated with the primary cell;

transmitting, on a second set of radio resources on the uplink component carrier associated with the primary cell, control information associated with the downlink transmissions responsive to receiving an assignment of radio resource on multiple downlink component carriers including the single downlink component carrier associated with the primary cell for the downlink transmissions, wherein the second set of radio resources is reserved for user terminals scheduled to receive downlink transmissions on the multiple downlink component carriers and the second set of resources are additional resources as compared to the first set of resources; and

receiving, on the single downlink component carrier, an indication to assign radio resources in the second set of radio resources when the user terminal is scheduled to receive the downlink transmissions on the multiple downlink component carriers.

18. (Cancelled)

19. (Previously presented) The method of claim 17 further comprising receiving control information from the base station on a downlink component carrier implicitly or explicitly indicating the second set of radio resources on the uplink component carrier associated with the primary cell.

20. (Previously presented) The method of claim 19 wherein receiving control information comprises receiving at least one of a downlink control channel index, number of downlink component carriers, and user terminal identifier implicitly identifying said second set of resources.
21. (Original) The method of claim 19 wherein receiving control information comprises receiving an uplink control channel index explicitly identifying said second set of resources.
22. (Original) The method of claim 21 wherein the explicit indication is received as radio resource control signaling.
23. (Currently amended) The method of claim 17, further comprising receiving, from a base station, an acknowledgement resource indication on the single downlink component carrier associated with the primary cell to dynamically assign radio resources in said second set of radio resources on the uplink component carrier associated with the primary cell when the user terminal is scheduled to receive downlink transmissions on the multiple downlink component carriers.
24. (Original) The method of claim 23 further comprising selecting the second set of resources from a semi-static set of uplink resources responsive to the acknowledgement resource indication.

25. (Currently amended) A user terminal for mobile communications, the user terminal comprising:

- a receiver to receive downlink transmissions from a base station;
- a transmitter to transmit control information associated with the downlink transmissions to a base station; and
- a controller to select radio resources for transmission of control information associated with the downlink transmissions, the controller configured to:
  - select a first set of radio resources on an uplink component carrier associated with a primary cell responsive to receiving an assignment of radio resources on a single downlink component carrier associated with the primary cell for the downlink transmissions, wherein the first set of radio resources is reserved for user terminals scheduled to receive downlink transmissions on the single downlink component carrier associated with the primary cell;
  - select a second set of radio resources on the uplink component carrier associated with the primary cell responsive to receiving an assignment of radio resources on multiple downlink component carriers including the single downlink component carrier associated with the primary cell for the downlink transmissions, wherein the second set of radio resources is reserved for user terminals scheduled to receive downlink transmissions on the multiple downlink component carriers and the second set of resources are additional resources as compared to the first set of resources; and
  - receive, on the single downlink component carrier, an indication to assign radio resources in the second set of radio resources when the user terminal is scheduled to receive the downlink transmissions on the multiple downlink component carriers.

26. (Cancelled)

27. (Previously presented) The user terminal of claim 25 wherein the controller is further configured to receive control information from the base station on a downlink component carrier implicitly or explicitly identifying the second set of radio resources on the uplink component carrier associated with the primary cell.

28. (Original) The user terminal of claim 27 wherein the controller is further configured to receive at least one of a downlink control channel index, number of downlink component carriers, and user terminal identifier implicitly identifying the second set of radio resources.

29. (Previously presented) The user terminal of claim 27 wherein the controller is further configured to receive an uplink control channel index explicitly identifying the second set of radio resources on the uplink component carrier associated with the primary cell.

30. (Original) The user terminal of claim 29 wherein the controller is further configured to receive the explicit indication as radio resource control signaling.

31. (Currently amended) The user terminal of claim 25 wherein the controller is further configured to receive, from a base station, an acknowledgement resource indication on a downlink component carrier dynamically assigning radio resources in said second set of radio resources on the uplink component carrier associated with the primary cell when the user terminal is scheduled to receive downlink transmissions on the multiple downlink component carriers.

32. (Original) The user terminal of claim 31 wherein the controller is configured to select the second set of resources from a semi-static set of uplink resources responsive to the acknowledgement resource indication.

33. (Currently amended) A method implemented by a user terminal in a mobile communication network, the method comprising:

receiving an assignment of radio resources for **[[a]]** downlink transmissions from a base station;

transmitting control information associated with the downlink transmissions on a first set of radio resources on an uplink component carrier associated with a primary cell responsive to receiving an assignment of **radio resources on** a first downlink component carrier associated with the primary cell for the downlink transmissions, wherein the first set of radio resources is reserved for user terminals scheduled to receive downlink transmissions on the first downlink component carrier associated with the primary cell;

transmitting control information associated with the downlink transmissions on a second set of radio resources on the uplink component carrier associated with the primary cell responsive to receiving an assignment of **radio resources on** the first downlink component carrier associated with the primary cell and a second downlink component carrier associated with a non-primary cell for the downlink transmissions, wherein the second set of radio resources is reserved for user terminals scheduled to receive downlink transmissions on the first downlink component carrier and the second downlink component carrier and the second set of resources are additional resources as compared to the first set of resources; and

receiving, on the first downlink component carrier, an indication to assign **radio resources in** the second set of radio resources when the user terminal is scheduled to receive the downlink transmissions on the first and second downlink component carriers.



34. (Currently amended) A user terminal for mobile communications, the user terminal comprising:

- a receiver to receive downlink transmissions from a base station;
- a transmitter to transmit control information associated with the downlink transmissions to a base station; and
- a controller to select radio resources for transmission of control information associated with downlink transmissions, the controller configured to:
  - select a first set of radio resources on an uplink component carrier associated with a primary cell responsive to receiving an assignment of radio resources on a first downlink component carrier associated with the primary cell for the downlink transmissions, wherein the first set of radio resources is reserved for user terminals scheduled to receive downlink transmissions on the first downlink component carrier associated with the primary cell;
  - select a second set of radio resources on the uplink component carrier associated with the primary cell responsive to receiving an assignment of radio resources on the first downlink component carrier associated with the primary cell and a second downlink component carrier associated with a non-primary cell for the downlink transmissions, wherein the second set of radio resources is reserved for user terminals scheduled to receive downlink transmissions on the first downlink component carrier and the second downlink component carrier and the second set of resources are additional resources as compared to the first set of resources; and
  - receive, on the first downlink component carrier, an indication to assign radio resources in the second set of radio resources when the user terminal is scheduled to receive the downlink transmissions on the first and second downlink component carriers.

35. (Cancelled)

36. (Currently amended) The method of claim 1, further comprising:

- receiving control signaling on the second set of radio resources if radio resources on a single downlink component carrier associated with a non-primary cell is assigned for the downlink transmissions.

37. (Cancelled)

38. (Currently amended) The base station of claim 9, further configured to:

receive control signaling on the second set of radio resources if radio resources on a single downlink component carrier associated with a non-primary cell is assigned for the downlink transmissions.

39. (Currently amended) The method of claim 17, further comprising:

transmitting control signaling on the second set of radio resources if radio resources on a single downlink component carrier associated with a non-primary cell is assigned for the downlink transmissions.

40. (Currently amended) The user terminal of claim 25, further configured to:

transmit control signaling on the second set of radio resources if radio resources on a single downlink component carrier associated with a non-primary cell is assigned for the downlink transmissions.

41. (Previously presented) The method of claim 1, further comprising:

if the first user terminal is scheduled to receive downlink transmissions on a second single downlink component carrier associated with a non-primary cell, receiving control information associated with the downlink transmissions to the first user terminal on the second set of radio resources on the uplink component carrier associated with the primary cell, wherein the second set of radio resources is reserved for user terminals scheduled to receive downlink transmissions on the second single downlink component carrier.

42. (Previously presented) The base station of claim 9, further configured to:

if the first user terminal is scheduled to receive downlink transmissions on a second single downlink component carrier associated with a non-primary cell, receive control information associated with the downlink transmissions to the first user terminal on the second set of radio resources on the uplink component carrier associated with the primary cell, wherein the second set of radio resources is reserved for user terminals scheduled to receive downlink transmissions on the second single downlink component carrier.

43. (Currently amended) A method implemented by a base station of receiving control information from a first user terminal and a second user terminal, the method comprising:

- scheduling downlink transmissions to the first user terminal on a single downlink component carrier associated with a primary cell and the second user terminal on multiple downlink component carriers including the single downlink component carrier associated with the primary cell; and
- receiving on a first set or a second set of resources on an uplink component carrier associated with a primary cell, including:
  - receiving control information associated with the downlink transmissions to the first user terminal on the first set of radio resources on the uplink component carrier associated with the primary cell, wherein the first set of radio resources is reserved for user terminals scheduled to receive downlink transmissions on the single downlink component carrier associated with the primary cell;
  - receiving control information associated with the downlink transmissions to the second user terminal on the second set of radio resources on the uplink component carrier associated with the primary cell, wherein the second set of radio resources is reserved for user terminals scheduled to receive downlink transmissions on the multiple downlink component carriers and the second set of resources are additional resources as compared to the first set of resources; and
  - transmitting, on the single downlink component carrier, an indication to assign radio resources in the second set of radio resources when the second user terminal is scheduled to receive the downlink transmissions on the multiple downlink component carriers.

44. (Currently amended) A base station comprising:

a transmitter to transmit user data on one or more downlink component carriers to a first user terminal and a second user terminal; and

a controller to schedule downlink transmissions to the first user terminal and the second user terminal, the controller configured to:

schedule downlink transmissions to the first user terminal on a single downlink component carrier associated with the primary cell and the second user terminal on multiple downlink component carriers including the single downlink component carrier associated with the primary cell; and

receiving on a first set or a second set of resources on an uplink component carrier associated with a primary cell, including:

receive control information associated with the downlink transmissions to the first user terminal on the first set of radio resources on the uplink component carrier associated with the primary cell, wherein the first set of radio resources is reserved for user terminals scheduled to receive downlink transmissions on the single downlink component carrier associated with the primary cell;

receive control information associated with the downlink transmissions to the second user terminal on the second set of radio resources on the uplink component carrier associated with the primary cell, wherein the second set of radio resources is reserved for user terminals scheduled to receive downlink transmissions on the multiple downlink component carriers and the second set of resources are additional resources as compared to the first set of resources; and

transmit, on the single downlink component carrier, an indication to assign radio resources in the second set of radio resources when the second user terminal is scheduled to receive the downlink transmissions on the multiple downlink component carriers.

45. (Previously presented) The method of claim 1, wherein the first user equipment is the same as the second user equipment.

46. (Previously presented) The method of claim 1, wherein the first user equipment is different from the second user equipment.

47. (Previously presented) The base station of claim 9, wherein the first user equipment is the same as the second user equipment.

48. (Previously presented) The base station of claim 9, wherein the first user equipment is different from the second user equipment.

49. (Previously presented) The method of claim 43, wherein the first user equipment is the same as the second user equipment.

50. (Previously presented) The method of claim 43, wherein the first user equipment is different from the second user equipment.

51. (Previously presented) The base station of claim 44, wherein the first user equipment is the same as the second user equipment.

52. (Previously presented) The base station of claim 44, wherein the first user equipment is different from the second user equipment.

**REMARKS**

After entry of this Amendment, claims 1-17, 19-25, 27-34, 36 and 38-52 are pending. Claims 1, 7, 9, 15, 17, 23, 25, 31, 33-34, 36, 38-40 and 43-44 are amended. Support is described by Applicant's disclosure such as at paragraphs [0009], [0010], [0011] and [0012]. Claims 18, 26, 35 and 37 are cancelled. No new matter is introduced by the present Response.

Favorable consideration is respectfully and earnestly solicited.

Respectfully submitted,

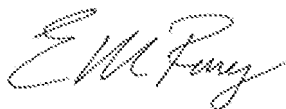

Edward M. Roney  
Registration No. 62,048  
Phone: 919.719.4870

Dated: June 20, 2016

<b>INFORMATION DISCLOSURE STATEMENT BY APPLICANT</b> ( Not for submission under 37 CFR 1.99)	Application Number	12896993
	Filing Date	2010-10-04
	First Named Inventor	David Astely et al.
	Art Unit	2648
	Examiner Name	Md K. Talukder
	Attorney Docket Number	4015-6942 / P30138-US2

U.S.PATENTS							Remove
Examiner Initial*	Cite No	Patent Number	Kind Code <sup>1</sup>	Issue Date	Name of Patentee or Applicant of cited Document	Pages,Columns,Lines where Relevant Passages or Relevant Figures Appear	
	1						

If you wish to add additional U.S. Patent citation information please click the Add button.

Add

U.S.PATENT APPLICATION PUBLICATIONS							Remove
Examiner Initial*	Cite No	Publication Number	Kind Code <sup>1</sup>	Publication Date	Name of Patentee or Applicant of cited Document	Pages,Columns,Lines where Relevant Passages or Relevant Figures Appear	
	1	20120147847	A1	2012-06-14	Matsumoto et al.	Corresponds to WO2009022474A1	

If you wish to add additional U.S. Published Application citation information please click the Add button.

Add

FOREIGN PATENT DOCUMENTS								Remove
Examiner Initial*	Cite No	Foreign Document Number <sup>3</sup>	Country Code <sup>2</sup> i	Kind Code <sup>4</sup>	Publication Date	Name of Patentee or Applicant of cited Document	Pages,Columns,Lines where Relevant Passages or Relevant Figures Appear	T <sup>5</sup>
	1	101765208	CN	A	2010-06-30	Huawei Technologies Co., Ltd	Machine Translation Included	
	2	2009022474	WO	A1	2009-02-19	Panasonic Corp.	Corresponds to US2012/0147847A1	

If you wish to add additional Foreign Patent Document citation information please click the Add button

Add

NON-PATENT LITERATURE DOCUMENTS								Remove
---------------------------------	--	--	--	--	--	--	--	--------

<b>INFORMATION DISCLOSURE STATEMENT BY APPLICANT</b> ( Not for submission under 37 CFR 1.99)	Application Number		12896993
	Filing Date		2010-10-04
	First Named Inventor	David Astely et al.	
	Art Unit		2648
	Examiner Name	Md K. Talukder	
	Attorney Docket Number		4015-6942 / P30138-US2

Examiner Initials*	Cite No	Include name of the author (in CAPITAL LETTERS), title of the article (when appropriate), title of the item (book, magazine, journal, serial, symposium, catalog, etc), date, pages(s), volume-issue number(s), publisher, city and/or country where published.	T <sup>5</sup>
	1	ZTE (source), "ACK/NACK Design for LTE-Advanced,"TSG-RAN WG1 #58bis, R1-093821, Miyazaki, Japan, October 12-16, 2009.	
	2	Infineon Technologies (source), "Clarification of UL DPCCH slot format information usage in IE 'DTX-DRX information',"3GPP TSG-RAN WG2 Meeting #65, Tdoc R2-091165, Athens, Greece February 9-13, 2009.	
	3	NTT DocCoMo, Inc. (source), "UL ACK/NACK resource allocation for DL semi-persistent scheduling," 3GPP TSG RAN WG2 #62, R2-082485 (resubmission of R2-081857), Kansas City, Missouri, USA, May 5-9, 2008.	

If you wish to add additional non-patent literature document citation information please click the Add button

**EXAMINER SIGNATURE**

Examiner Signature		Date Considered	
--------------------	--	-----------------	--

\*EXAMINER: Initial if reference considered, whether or not citation is in conformance with MPEP 609. Draw line through a citation if not in conformance and not considered. Include copy of this form with next communication to applicant.

<sup>1</sup> See Kind Codes of USPTO Patent Documents at [www.USPTO.GOV](http://www.USPTO.GOV) or MPEP 901.04. <sup>2</sup> Enter office that issued the document, by the two-letter code (WIPO Standard ST.3). <sup>3</sup> For Japanese patent documents, the indication of the year of the reign of the Emperor must precede the serial number of the patent document. <sup>4</sup> Kind of document by the appropriate symbols as indicated on the document under WIPO Standard ST.16 if possible. <sup>5</sup> Applicant is to place a check mark here if English language translation is attached.



**INFORMATION DISCLOSURE  
STATEMENT BY APPLICANT**  
( Not for submission under 37 CFR 1.99)

Application Number	12896993		
Filing Date	2010-10-04		
First Named Inventor	David Astely et al.		
Art Unit	2648		
Examiner Name	Md K. Talukder		
Attorney Docket Number	4015-6942 / P30138-US2		

**CERTIFICATION STATEMENT**

Please see 37 CFR 1.97 and 1.98 to make the appropriate selection(s):

That each item of information contained in the information disclosure statement was first cited in any communication from a foreign patent office in a counterpart foreign application not more than three months prior to the filing of the information disclosure statement. See 37 CFR 1.97(e)(1).

**OR**

That no item of information contained in the information disclosure statement was cited in a communication from a foreign patent office in a counterpart foreign application, and, to the knowledge of the person signing the certification after making reasonable inquiry, no item of information contained in the information disclosure statement was known to any individual designated in 37 CFR 1.56(c) more than three months prior to the filing of the information disclosure statement. See 37 CFR 1.97(e)(2).

See attached certification statement.

The fee set forth in 37 CFR 1.17 (p) has been submitted herewith.

A certification statement is not submitted herewith.

**SIGNATURE**

A signature of the applicant or representative is required in accordance with CFR 1.33, 10.18. Please see CFR 1.4(d) for the form of the signature.

Signature	/Edward M. Roney/	Date (YYYY-MM-DD)	2016-06-20
Name/Print	Edward M. Roney	Registration Number	62048

This collection of information is required by 37 CFR 1.97 and 1.98. The information is required to obtain or retain a benefit by the public which is to file (and by the USPTO to process) an application. Confidentiality is governed by 35 U.S.C. 122 and 37 CFR 1.14. This collection is estimated to take 1 hour to complete, including gathering, preparing and submitting the completed application form to the USPTO. Time will vary depending upon the individual case. Any comments on the amount of time you require to complete this form and/or suggestions for reducing this burden, should be sent to the Chief Information Officer, U.S. Patent and Trademark Office, U.S. Department of Commerce, P.O. Box 1450, Alexandria, VA 22313-1450. **DO NOT SEND FEES OR COMPLETED FORMS TO THIS ADDRESS. SEND TO: Commissioner for Patents, P.O. Box 1450, Alexandria, VA 22313-1450.**

## Privacy Act Statement

The Privacy Act of 1974 (P.L. 93-579) requires that you be given certain information in connection with your submission of the attached form related to a patent application or patent. Accordingly, pursuant to the requirements of the Act, please be advised that: (1) the general authority for the collection of this information is 35 U.S.C. 2(b)(2); (2) furnishing of the information solicited is voluntary; and (3) the principal purpose for which the information is used by the U.S. Patent and Trademark Office is to process and/or examine your submission related to a patent application or patent. If you do not furnish the requested information, the U.S. Patent and Trademark Office may not be able to process and/or examine your submission, which may result in termination of proceedings or abandonment of the application or expiration of the patent.

The information provided by you in this form will be subject to the following routine uses:

1. The information on this form will be treated confidentially to the extent allowed under the Freedom of Information Act (5 U.S.C. 552) and the Privacy Act (5 U.S.C. 552a). Records from this system of records may be disclosed to the Department of Justice to determine whether the Freedom of Information Act requires disclosure of these records.
2. A record from this system of records may be disclosed, as a routine use, in the course of presenting evidence to a court, magistrate, or administrative tribunal, including disclosures to opposing counsel in the course of settlement negotiations.
3. A record in this system of records may be disclosed, as a routine use, to a Member of Congress submitting a request involving an individual, to whom the record pertains, when the individual has requested assistance from the Member with respect to the subject matter of the record.
4. A record in this system of records may be disclosed, as a routine use, to a contractor of the Agency having need for the information in order to perform a contract. Recipients of information shall be required to comply with the requirements of the Privacy Act of 1974, as amended, pursuant to 5 U.S.C. 552a(m).
5. A record related to an International Application filed under the Patent Cooperation Treaty in this system of records may be disclosed, as a routine use, to the International Bureau of the World Intellectual Property Organization, pursuant to the Patent Cooperation Treaty.
6. A record in this system of records may be disclosed, as a routine use, to another federal agency for purposes of National Security review (35 U.S.C. 181) and for review pursuant to the Atomic Energy Act (42 U.S.C. 218(c)).
7. A record from this system of records may be disclosed, as a routine use, to the Administrator, General Services, or his/her designee, during an inspection of records conducted by GSA as part of that agency's responsibility to recommend improvements in records management practices and programs, under authority of 44 U.S.C. 2904 and 2906. Such disclosure shall be made in accordance with the GSA regulations governing inspection of records for this purpose, and any other relevant (i.e., GSA or Commerce) directive. Such disclosure shall not be used to make determinations about individuals.
8. A record from this system of records may be disclosed, as a routine use, to the public after either publication of the application pursuant to 35 U.S.C. 122(b) or issuance of a patent pursuant to 35 U.S.C. 151. Further, a record may be disclosed, subject to the limitations of 37 CFR 1.14, as a routine use, to the public if the record was filed in an application which became abandoned or in which the proceedings were terminated and which application is referenced by either a published application, an application open to public inspections or an issued patent.
9. A record from this system of records may be disclosed, as a routine use, to a Federal, State, or local law enforcement agency, if the USPTO becomes aware of a violation or potential violation of law or regulation.



(12) 发明专利申请

(10) 申请公布号 CN 101765208 A

(43) 申请公布日 2010.06.30

(21) 申请号 200810188931.3

(22) 申请日 2008.12.26

(71) 申请人 华为技术有限公司

地址 518129 广东省深圳市龙岗区坂田华为  
总部办公楼

(72) 发明人 薛丽霞

(74) 专利代理机构 北京同立钧成知识产权代理  
有限公司 11205

代理人 刘芳

(51) Int. Cl.

H04W 72/04(2009.01)

H04W 28/12(2009.01)

权利要求书 3 页 说明书 10 页 附图 5 页

(54) 发明名称

资源分配的方法、网络设备和无线系统

(57) 摘要

本发明公开了一种资源分配的方法、网络设备和无线系统。该方法包括根据获取到的后向兼容系统中的资源分配粒度,确定演进系统中的资源分配粒度;根据演进系统中的资源分配粒度,指示演进系统中的资源分配情况。可以根据后向兼容系统中分支载波的带宽的资源分配粒度,确定演进系统中分支载波聚合后的带宽的资源分配情况。或者,还可以根据后向兼容系统中各分支载波的带宽的资源分配粒度,确定演进系统中各分支载波的资源分配情况。通过本发明实施例可以保持 LTE-A 终端和 LTE 终端资源分配的兼容性,并且节省资源分配信令的开销。

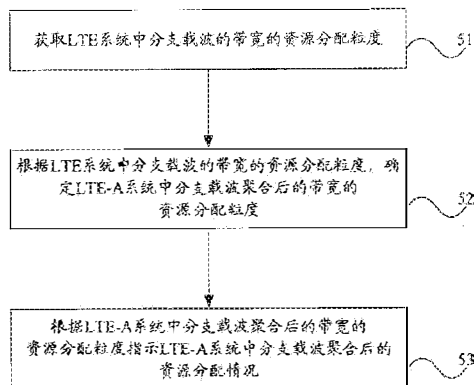

CN 101765208 A

1. 一种资源分配的方法,其特征在于,包括:

根据获取到的后向兼容系统中的资源分配粒度,确定演进系统中的资源分配粒度;

根据演进系统中的资源分配粒度,指示演进系统中的资源分配情况。

2. 根据权利要求1所述的方法,其特征在于,

所述根据获取到的后向兼容系统中的资源分配粒度,确定演进系统中的资源分配粒度,包括:

获取后向兼容系统中,分支载波的带宽的资源分配粒度;

根据后向兼容系统中分支载波的带宽的资源分配粒度,确定演进系统中,分支载波聚合后的带宽的资源分配粒度;

所述根据演进系统中的资源分配粒度,指示演进系统中的资源分配情况,包括:根据演进系统中分支载波聚合后的带宽的资源分配粒度,指示演进系统中,分支载波聚合后的资源分配情况。

3. 根据权利要求2所述的方法,其特征在于,所述根据后向兼容系统中分支载波的带宽的资源分配粒度,确定演进系统中,分支载波聚合后的带宽的资源分配粒度包括:

根据后向兼容系统中所有分支载波的带宽的资源分配粒度,确定演进系统中,分支载波聚合后的带宽的资源分配粒度;或者,

在所有分支载波中确定配置给终端的分支载波,根据配置给终端的分支载波的带宽的资源分配粒度,确定演进系统中,分支载波聚合后的带宽的资源分配粒度。

4. 根据权利要求3所述的方法,其特征在于,所述根据后向兼容系统中分支载波的带宽的资源分配粒度,确定演进系统中,分支载波聚合后的带宽的资源分配粒度的计算公式为:

$P = \text{LCM}(P_1, \dots, P_n)$ , 或者,  $P = 0.5 \times \text{LCM}(P_1, \dots, P_n)$ ; 其中,  $P_1, \dots, P_n$  分别为后向兼容系统中所有分支载波或配置给终端的分支载波的带宽的资源分配粒度,  $P$  为演进系统中分支载波聚合后的带宽的资源分配粒度,  $\text{LCM}(P_1, \dots, P_n)$  为  $P_1, \dots, P_n$  的最小公倍数, 对于  $P = 0.5 \times \text{LCM}(P_1, \dots, P_n)$  需要满足  $\text{LCM}(P_1, \dots, P_n) \bmod 2 = 0$ 。

5. 根据权利要求2所述的方法,其特征在于,所述根据演进系统中分支载波聚合后的带宽的资源分配粒度,指示演进系统中,分支载波聚合后的资源分配情况包括:

根据演进系统中分支载波聚合后的带宽的资源分配粒度,将分支载波的带宽包括的资源块分为一个或多个资源块组;

每个资源块组用一个比特指示;或者,每个足额的资源块组用一个比特指示,所有分支载波内不足额的资源块组联合用一个比特指示。

6. 根据权利要求2所述的方法,其特征在于,所述根据演进系统中分支载波聚合后的带宽的资源分配粒度,指示演进系统中,分支载波聚合后的资源分配情况包括:

根据演进系统中分支载波聚合后的带宽的资源分配粒度,将各分支载波的带宽包括的资源块分为一个或多个资源块组;

将所有分支载波的带宽包括的资源块组分为  $N$  个资源块组子集,且  $N = \frac{P}{2^k}$ ; 其中,  $N$  为资源块组子集的个数,  $P$  为演进系统中分支载波聚合后的带宽的资源分配粒度,  $k$  为大于等于 0 的整数;

采用比特映射的方式指示各资源块组子集中资源块的分配情况。

7. 根据权利要求 1 所述的方法,其特征在于,所述根据获取到的后向兼容系统中的资源分配粒度,确定演进系统中的资源分配粒度,包括:

获取后向兼容系统中,各分支载波的带宽的资源分配粒度;

根据后向兼容系统中各分支载波的带宽的资源分配粒度,确定演进系统中,各分支载波的带宽的资源分配粒度;

所述根据演进系统中的资源分配粒度,指示演进系统中的资源分配情况,包括:根据演进系统中各分支载波的带宽的资源分配粒度,指示演进系统中,各分支载波的资源分配情况。

8. 根据权利要求 7 所述的方法,其特征在于,所述根据后向兼容系统中各分支载波的带宽的资源分配粒度,确定演进系统中,各分支载波的带宽的资源分配粒度的计算公式为:

$P = k \times P_1$ , 或者,  $P = 0.5 \times k \times P_1$ ; 其中,  $P_1$  为后向兼容系统中一个分支载波的带宽的资源分配粒度,  $P$  为演进系统中该分支载波的带宽的资源分配粒度,  $k$  为大于等于 2 的整数, 对于  $P = 0.5 \times k \times P_1$  需要满足  $(k \times P_1) \bmod 2 = 0$ 。

9. 根据权利要求 7 所述的方法,其特征在于,所述根据演进系统中各分支载波的带宽的资源分配粒度,指示演进系统中,各分支载波的资源分配情况包括:

根据演进系统中一个分支载波的带宽的资源分配粒度,将演进系统中该分支载波的带宽包括的资源块分为一个或多个资源块组;

将所述资源块组分为  $N$  个资源块组子集,且  $N = \frac{P}{2^k}$ ; 其中,  $N$  为资源块组子集的个数,  $P$  为演进系统中该分支载波的带宽的分配粒度,  $k$  为大于等于 0 的整数;

采用比特映射的方式指示各资源块组子集中资源块的分配情况。

10. 根据权利要求 6 或 9 所述的方法,其特征在于,所述采用比特映射的方式指示各资源块组子集中资源块的分配情况包括:在一资源块组子集中,用一个比特指示该资源块组子集中多个资源块的分配情况。

11. 根据权利要求 1 所述的方法,其特征在于,还包括:

通过协议中静态配置的方式使终端确定演进系统中的资源分配粒度;

或者,通过单播的方式将演进系统中各分支载波的带宽的资源分配粒度发送给终端;

或者,通过广播的方式将演进系统中各分支载波的带宽的资源分配粒度发送给终端。

12. 一种网络设备,其特征在于,包括:

资源确定单元,用于根据获取到的后向兼容系统中的资源分配粒度,确定演进系统中的资源分配粒度;

资源分配单元,用于根据所述资源确定单元所确定的演进系统中的资源分配粒度,指示演进系统中的资源分配情况。

13. 根据权利要求 12 所述的网络设备,其特征在于,

所述资源确定单元包括:

获取模块,用于获取后向兼容系统中,分支载波的带宽的资源分配粒度;

确定模块,用于根据获取模块得到的后向兼容系统中分支载波的带宽的资源分配粒

度,确定演进系统中,分支载波聚合后的带宽的资源分配粒度;

所述资源分配单元包括:指示模块,用于根据确定模块得到的演进系统中分支载波聚合后的带宽的资源分配粒度,指示演进系统中,分支载波聚合后的资源分配情况。

14. 根据权利要求 13 所述的设备,其特征在于:所述确定模块具体用于根据后向兼容系统中所有分支载波的带宽的资源分配粒度,确定演进系统中,分支载波聚合后的带宽的资源分配粒度;或者,在所有分支载波中确定配置给终端的分支载波,根据配置给终端的分支载波的带宽的资源分配粒度,确定演进系统中,分支载波聚合后的带宽的资源分配粒度。

15. 根据权利要求 13 所述的设备,其特征在于:

所述指示模块具体用于根据演进系统中分支载波聚合后的带宽的资源分配粒度,将分支载波的带宽包括的资源块分为一个或多个资源块组;每个资源块组用一个比特指示;或者,每个足额的资源块组用一个比特指示,所有分支载波内不足额的资源块组联合用一个比特指示;或者,

所述指示模块具体用于根据演进系统中分支载波聚合后的带宽的资源分配粒度,将各分支载波的带宽包括的资源块分为一个或多个资源块组;将所有分支载波的带宽包括的资源块组分为  $N$  个资源块组子集,且  $N = \frac{P}{2^k}$ ;其中,  $N$  为资源块组子集的个数,  $P$  为演进系统中分支载波聚合后的带宽的资源分配粒度,  $k$  为大于等于 0 的整数;采用比特映射的方式指示各资源块组子集中资源块的分配情况。

16. 根据权利要求 12 所述的网络设备,其特征在于,

所述资源确定单元包括:

获取模块,用于获取后向兼容系统中,各分支载波的带宽的资源分配粒度;

确定模块,用于根据获取模块得到的后向兼容系统中各分支载波的带宽的资源分配粒度,确定演进系统中,各分支载波的带宽的资源分配粒度;

所述资源分配单元包括:指示模块,用于根据确定模块得到的演进系统中各分支载波的带宽的资源分配粒度,指示演进系统中,各分支载波的资源分配情况。

17. 根据权利要求 16 所述的设备,其特征在于:所述指示模块具体用于根据演进系统中一个分支载波的带宽的资源分配粒度,将演进系统中该分支载波的带宽包括的资源块分为一个或多个资源块组;将所述资源块组分为  $N$  个资源块组子集,且  $N = \frac{P}{2^k}$ ;其中,  $N$  为资源块组子集的个数,  $P$  为演进系统中该分支载波的带宽的分配粒度,  $k$  为大于等于 0 的整数;采用比特映射的方式指示各资源块组子集中资源块的分配情况。

18. 根据权利要求 12 所述的设备,其特征在于,还包括:

通知模块,用于通过协议中静态配置的方式,或者单播的方式,或者广播的方式,将资源确定模块得到的演进系统中的资源分配粒度通知给终端。

19. 一种无线系统,其特征在于,包括:

网络设备,用于根据后向兼容系统中分支载波的带宽的资源分配粒度,确定演进系统中,分支载波聚合后的带宽的资源分配粒度,指示演进系统中,分支载波聚合后的资源分配情况;或者,用于根据后向兼容系统中各分支载波的带宽的资源分配粒度,确定演进系统中,各分支载波的带宽的资源分配粒度,指示演进系统中,各分支载波的资源分配情况。

## 资源分配的方法、网络设备和无线系统

### 技术领域

[0001] 本发明涉及无线通信技术,特别涉及一种资源分配的方法、网络设备和无线系统。

### 背景技术

[0002] 在长期演进(Long Term Evolved, LTE)系统中,网络将上下行采用的确切的系统带宽大小通过广播信令通知给网络内的每一个终端,进而终端再根据系统带宽所包括的资源块(Resource block, RB)数目确定某些资源分配方法的资源分配粒度,例如下行的资源分配方法0和1(Resource allocation type0/1, RA type 0/1)的粒度。之后,网络还会通过资源分配信令将具体资源分配的信息发送给需要传输数据的终端,终端根据接收的资源分配信令信息确定网络具体分配的时频资源位置,并在相应的时频资源位置上发送或是接收数据,实现网络和终端的数据传输和通信。

[0003] 在演进的LTE系统(LTE-A)中,为了支持更大的带宽,一种可能的方式是将多个分支载波进行聚合,即将多个分支载波的资源同时调度给一个终端使用。多个分支载波占用的频谱可以是连续的,也可以是非连续的,每个分支载波的带宽可以相同,也可以不同,每个分支载波可以是兼容LTE终端的载波,也可以仅仅是支持LTE-A终端的载波,那么LTE终端在该LTE-A载波上不能进行数据传输和通信。现有LTE-A资源分配技术中是根据所有分支载波聚合后的整个系统带宽确定的资源分配粒度。

[0004] 发明人在实现本发明的过程中发现现有技术至少存在如下问题:现有LTE-A资源分配技术是根据所有分支载波聚合后的整个系统带宽确定的资源分配粒度,这种分配技术会造成LTE-A系统的后向不兼容,资源漏洞和浪费。

### 发明内容

[0005] 本发明是提供一种资源分配的方法、网络设备和无线系统,以使LTE-A资源分配技术能够后向兼容。

[0006] 本发明实施例提供了一种资源分配的方法,包括:

[0007] 根据获取到的后向兼容系统中的资源分配粒度,确定演进系统中的资源分配粒度;

[0008] 根据演进系统中的资源分配粒度,指示演进系统中的资源分配情况。

[0009] 本发明实施例提供了一种网络设备,包括:

[0010] 资源确定单元,用于根据获取到的后向兼容系统中的资源分配粒度,确定演进系统中的资源分配粒度;

[0011] 资源分配单元,用于根据所述资源确定单元所确定的演进系统中的资源分配粒度,指示演进系统中的资源分配情况。

[0012] 本发明实施例提供了一种无线系统,其特征在于,包括:

[0013] 网络设备,用于根据后向兼容系统中分支载波的带宽的资源分配粒度,确定演进系统中,分支载波聚合后的带宽的资源分配粒度,指示演进系统中,分支载波聚合后的资源

分配情况；或者，用于根据后向兼容系统中各分支载波的带宽的资源分配粒度，确定演进系统中，各分支载波的带宽的资源分配粒度，指示演进系统中，各分支载波的资源分配情况。

[0014] 由上述技术方案可知，本发明实施例根据分支载波在后向兼容系统中的分配粒度得到在演进系统中的分配粒度，由于演进系统中的分配粒度是考虑了后向兼容系统中的分配粒度，而非现有技术只根据演进系统中的带宽，可以避免现有技术由于没有考虑后向兼容系统中的分配粒度造成的资源冲突问题，可以保证对 LTE-A 终端和 LTE 终端的兼容。

#### 附图说明

- [0015] 图 1 为现有资源分配方法示意图；  
 [0016] 图 2 为本发明第一实施例的方法流程示意图；  
 [0017] 图 3 为本发明第二实施例的资源分配方法示意图；  
 [0018] 图 4 为本发明第四实施例的资源分配方法示意图；  
 [0019] 图 5 为本发明第五实施例的方法流程示意图；  
 [0020] 图 6 为本发明第六实施例的资源分配方法示意图；  
 [0021] 图 7 为本发明第七实施例的资源分配方法示意图；  
 [0022] 图 8 为本发明第八实施例的资源分配方法示意图；  
 [0023] 图 9 为本发明第九实施例的资源分配方法示意图；  
 [0024] 图 10 为本发明第十实施例的网络设备的结构示意图；  
 [0025] 图 11 为本发明第十一实施例的网络设备的结构示意图。

#### 具体实施方式

[0026] 下面通过附图和实施例，对本发明的技术方案做进一步的详细描述。

[0027] 在 LTE 系统的下行资源分配中，每个时间传输单元对应的资源分配信令中承载终端用户资源分配的类型和对应的资源分配信息，分为 RA type0、RA type1、RA type2。RA type0 是用比特映射 (Bitmap) 的方式指示资源块组 (RBG) 的分配情况，其中每个比特指示对应的 RBG 分配与否，一个 RBG 也就是资源分配的最小粒度，每个资源块组 (RBG) 包括若干个资源块 (Resource Block, RB)。每个资源块组包括的资源块的个数是由系统带宽包括的所有 RB 总数目决定的，即 RBG 的大小是系统带宽包含 RB 个数的一个函数。不同的系统带宽对应的资源块组的大小不同，即资源分配的最小粒度不同。参见表 1 为系统带宽包含的资源块的个数 N<sub>RB</sub><sup>BL</sup> 与粒度 P 的关系。

[0028] 表 1

[0029]

N <sub>RB</sub> <sup>BL</sup>	P
≤ 10	1
11 ~ 26	2



$N_{RB}^{DL}$	P
27 ~ 63	3
64 ~ 110	4

[0030]

[0031] 如果系统带宽包含的资源块的个数为  $N_{RB}^{DL}$ , 每个资源块组的大小 (即粒度) 为 P, 对于 RA type0 的分配方式, 在资源分配信令中需要  $N_{RBG} = \left\lceil \frac{N_{RB}^{DL}}{P} \right\rceil$  个比特来表示具体的资源分配情况。其中,  $\lceil * \rceil$  表示向上取整。

[0032] 在同一系统带宽情况下, RA type1 和 RA type0 占用资源分配信令的比特数是相同的, 也是采用比特映射 (bitmap) 方式指示的。为了区分具体的资源分配类型是 RA type 0 还是 RA type 1, 在资源分配的信令中有 1 个比特的信息进行区分。RA type1 根据系统带宽将资源块组分为 P 个资源块组子集, 例如, RA type0 中每个资源块组包括的资源块的个数为 P。因此需要  $\lceil \log_2(P) \rceil$  个比特表示被调度终端用户的资源是哪个资源块组子集的。为了能够指示尽量多的资源, 还需要 1 个比特用于指示资源分配的起始方向, 即是从左还是从右指示资源分配。因此用于指示被调度的资源块的比特数目为  $N_{RB}^{TYPE1} = \left\lceil \frac{N_{RB}^{DL}}{P} \right\rceil - \lceil \log_2(P) \rceil - 1$ ,

每个比特可以指示对应的资源块组子集中的 RB 是否被调用, 而且对被调度终端用户的资源分配也仅限制在一个子集中进行。

[0033] 当从 LTE 系统扩展到下一代的 LTE-A 系统时, 现有资源分配的方法是直接根据载波聚合后的带宽确定资源分配粒度, 而不考虑具体的每个分支载波针对 LTE 用户的资源分配粒度情况。参见表 2 为载波聚合后的带宽包含的 RB 个数、载波聚合后的资源分配粒度及资源分配所需要的比特数目之间的关系。

[0034] 表 2

[0035]

$N_{RB}^{DL}$	64 ~ 110	111 ~ 220	221 ~ 330	331 ~ 440	441 ~ 550
P	4	6	8	10	12
资源分配比特数	28	37	42	44	46

[0036]

[0037] 图 1 为现有资源分配方法示意图, 载波聚合前的两个分支载波均为 10M (根据现有技术得到此时包括的资源块的个数为 50), 通过表 1 可以得知每个分支载波的资源分配粒度均为 3, 即每个分支载波的每个资源块组由 3 个资源块组成, 这样, 对于这两个分支载波中 LTE 用户进行资源分配 (RA type0) 的粒度为 3; 载波聚合后的带宽为 20M (包括的资源块的个数为 100), 通过表 2 得知载波聚合后的资源分配的粒度为 4, 即聚合后的带宽内的每个 RBG 由 4 个 RB 组成。从图 1 可以看出, 当载波聚合后的 RBG1 (对应 RB4 ~ RB7) 分配给

LTE-A 终端时,与之对应的分支载波中的 RBG1 和 RBG2 不能再以 RBG 为单位分配给 LTE 终端,即在与之对应的分支载波中不能采用 RA type 0 方法将 RBG1 和 RBG2 分配给 LTE 终端,这样对应的没有被分配出去的 RB3 和 RB8 不能以此方式分配给 LTE 终端,这样造成了分支载波 RGB1、RGB2 中两端 RB 的资源浪费,或者调度器协调除 RA type 0 资源分配方法将 RB3 和 RB8 分配给终端,这样可以将 RB3 和 RB8 资源利用起来,但将增加调度器的复杂度。

[0038] 为此,不能仅仅以载波聚合后的带宽确定资源分配粒度,需要结合具体的每个分支载波针对 LTE 终端的分配粒度再确定载波聚合后 LTE-A 系统的资源分配粒度,以确保 LTE 和 LTE-A 系统的资源分配方法兼容,避免资源的浪费。因此,本发明实施例提供了一种资源分配方法,包括:根据获取到的后向兼容系统中的资源分配粒度,确定演进系统中的资源分配粒度;根据演进系统中的资源分配粒度,指示演进系统中的资源分配情况。本实施例根据分支载波在后向兼容系统中的分配粒度得到在演进系统中的分配粒度,由于演进系统中的分配粒度是考虑了后向兼容系统中的分配粒度,而非现有技术只根据演进系统中的带宽,可以避免现有技术由于没有考虑后向兼容系统中的分配粒度造成的资源冲突问题,可以保证对 LTE-A 终端和 LTE 终端的兼容。下面具体描述上述的方法:

[0039] 图 2 为本发明第一实施例的方法流程示意图,包括:

[0040] 步骤 21:网络设备(例如基站)获取后向兼容系统中,各分支载波的带宽的资源分配粒度。

[0041] 下面以后向兼容系统为 LTE 系统、演进系统为 LTE-A 系统为例。

[0042] 步骤 22:网络设备根据 LTE 系统中各分支载波的带宽的资源分配粒度,确定 LTE-A 系统中各分支载波的带宽的资源分配粒度。

[0043] 具体的计算公式为: $P = k \times P1$ ,或者, $P = 0.5 \times k \times P1$ (此时需要  $(k \times P1) \bmod 2 = 0$ );其中, $P1$  为 LTE 系统中一个分支载波的带宽的资源分配粒度, $P$  为 LTE-A 系统中该分支载波的带宽的资源分配粒度, $k$  为大于等于 2 的整数。例如,两个分支载波分别为 10M(LTE 系统中对应的资源分配粒度为 3)和 20M(LTE 系统中对应的资源分配粒度为 4),在 LTE-A 系统中,可以将 10M 的分支载波的资源分配粒度选为 3、6、9 等,可以将 20M 的分支载波的资源分配粒度选为 4、6、8 等。

[0044] 步骤 23:网络设备根据 LTE-A 系统中各分支载波的带宽的资源分配粒度,指示 LTE-A 系统中各分支载波的资源分配情况。

[0045] 具体的,在资源分配时,可以采用 RA type0 方式,也可以采用 RA type1 方式。对于 RA type0 方式,在每个分支载波内,按照 LTE-A 系统中该分支载波的粒度,将若干个 RB 组成一个 RBG,用每个比特指示相应的 RBG 是否分配。

[0046] 但是,对于 RA type1 方式,由于采用上述倍数的粒度选择方法后,LTE-A 系统中的资源分配粒度较 LTE 系统中的资源分配粒度大(通常是倍数的关系)。例如,图 3 为本发明第二实施例的资源分配方法示意图。参见图 3,以一个 20M 的分支载波为例,该带宽包括 100 个资源块。对于 LTE 终端,分配粒度为 4,资源分配占用的比特数目为 25,对于 LTE-A 终端,分配粒度为 8,资源分配占用的比特数目为 13。从图 3 可以看出,当针对 LTE-A 终端的 RBG0 分配给某一 LTE-A 终端时,与之对应的针对 LTE 终端的 RBG0、RBG1 不能再分配给 LTE 终端;当针对 LTE 终端的 RBG5 分配给某一 LTE 终端时,与之对应的针对 LTE-A 终端的 RBG2 不能再采用 RA type0 的方式分配给 LTE-A 终端。但是可以采用其他方式,例如 RA type1 的

方式分配给 LTE-A 终端或者以同样的方式分配给其他的 LTE 终端,采用不同的分配方式进行资源分配,可以使资源分配的方法更灵活,更好地保持 LTE 终端和 LTE-A 终端的兼容性。

[0047] 对于 RA type1 方式,若仍旧将 RBG 分为与资源分配粒度同样多的 RBG 子集,很可能出现指示比特位数不够及不能很好获得频率分集增益的问题。因为 RA type1 和 RA type0 占用同样的比特数,对于 LTE-A 终端,由于其分配粒度为 8,那么相应的资源块组子集的个数也为 8,另外需要一个比特指示方向(从左还是从后指示资源块),由于此时的资源比特数目为 13,则只有 9 个比特用于指示子集中资源块分配与否,从图 3 可以看出,9 个比特只能指示一个资源块组中的 8 个资源块即另一个资源块组中的 1 个资源块。这样并不能使子集中全部的资源块均被覆盖到,还使得指示的资源块是集成的,不能很好地获得数据传输的频率分集增益。

[0048] 为此,对于 RA type1:将该分支载波中的资源块组分为 N 个资源块组子集,且  $N = \frac{P}{2^k}$ ;其中, N 为资源块组子集的个数, P 为 LTE-A 系统中该分支载波的带宽的分配粒度, k 为大于等于 0 的整数;用比特指示各资源块组子集中资源块的分配情况。具体地,图 4 为本发明第四实施例的资源分配方法示意图。参见图 4,以 LTE-A 的 P = 8 为例,将资源块组分为 4 个资源块组子集(k = 1)。第一个子集中包括 LTE-A 的 RBG0、RBG4、RBG8、RBG12,第二个子集包括 LTE-A 的 RBG1、RBG5、RBG9,第三个子集包括 LTE-A 的 RBG2、RBG6、RBG10,第四个子集包括 LTE-A 的 RBG3、RBG7、RBG11。对于 LTE 终端,仍可以采用现有技术分为 4 个子集。

[0049] 对于 LTE-A 终端,在 RA type1 方式下分为 4 个子集,这样需要 2 个比特指示 RB 在哪个子集中,用一个比特指示方向(从左还是右指示),这时还剩余 10 个比特,每个比特指示子集中的一个 RB 分配与否。若认为此时指示的资源仍旧不够分散,可以用一个比特指示两个资源块是否分配,此时可以覆盖每个子集中至少 3 个资源块组的分配情况,实现指示的资源较为分散,提高频率分集增益。当然,每个比特还可以指示更多的资源块,当每个比特指示较多的资源块时,用于资源分配的比特数目足以指示每个子集中所有资源块的分配情况时,可以将用于指示方向的比特节省下来用于其他用途,例如,用于校验。

[0050] 上述以其中的一个分支载波为例,另一个分支载波的处理流程如上所述,不再赘述。

[0051] 上述采用 RA type1 方式时,通过将资源块组划分为小于分配粒度的资源块组子集,可以增加用于指示资源块比特数目,使指示的资源块更多更分散,当用一个比特指示多个资源块时可以进一步指示更多和更分散的资源块,提高频率分集增益。

[0052] 上述实现了网络侧对终端的资源分配,为了使终端准确地调度资源,需要将资源分配粒度发送给终端,资源分配粒度是采用上述根据各分支载波的情况获得的各分支载波的带宽的资源分配粒度。可以采用如下方式下发资源分配粒度:

[0053] 方式一:采用静态的方式。例如,网络侧通过协议以固定表格的方式静态配置终端的资源分配粒度。

[0054] 方式二:采用半静态的方式。例如,网络侧通过高层信令根据终端的业务情况半静态地改变资源分配粒度,并将改变后的资源分配粒度通过单播或广播的方式发送给终端。

[0055] 本实施例根据 LTE 系统中各分支载波的资源分配粒度,独立地确定各分支载波在

LTE-A 系统中的资源分配粒度,可以保证 LTE-A 和 LTE 终端的兼容,节省资源。通过将资源块组分为小于分配粒度的资源块组子集可以提高频率分集增益。通过一个比特指示更多的资源块,可以进一步地提高频率分集增益。

[0056] 图 5 为本发明第五实施例的方法流程示意图,包括:

[0057] 步骤 51:网络设备获取 LTE 系统中,分支载波的带宽的资源分配粒度。

[0058] 步骤 52:网络设备根据 LTE 系统中分支载波的带宽的资源分配粒度,确定 LTE-A 系统中分支载波聚合后的带宽的资源分配粒度。

[0059] 其中,网络设备可以根据后向兼容系统中所有分支载波的带宽的资源分配粒度,确定演进系统中,分支载波聚合后的带宽的资源分配粒度;或者,网络设备在所有分支载波中确定配置给终端的分支载波,根据配置给终端的分支载波的带宽的资源分配粒度,确定演进系统中,分支载波聚合后的带宽的资源分配粒度。例如,分支载波为第一载波、第二载波、第三载波,网络设备可以根据第一载波、第二载波和第三载波在 LTE 系统中的资源分配粒度确定 LTE-A 系统中载波聚合后的资源分配粒度;也可以首先确定配置给 UE 的载波,(例如适合 UE 的为第一载波和第二载波),则根据第一载波和第二载波在 LTE 系统中的资源分配粒度确定这个 LTE-A UE 载波聚合后的资源分配粒度。

[0060] 具体的计算公式为: $P = \text{LCM}(P_1, \dots, P_n)$ ,或者, $P = 0.5 \times \text{LCM}(P_1, \dots, P_n)$ (此时需要  $\text{LCM}(P_1, \dots, P_n) \bmod 2 = 0$ );其中, $P_1, \dots, P_n$  分别为需要进行聚合后资源分配粒度计算的分支载波(所有的分支载波或配置给终端的分支载波)在 LTE 系统中的资源分配粒度, $P$  为 LTE-A 系统中各分支载波聚合后的带宽的资源分配粒度, $\text{LCM}(P_1, \dots, P_n)$  为  $P_1, \dots, P_n$  的最小公倍数。例如,图 6 为本发明第六实施例的资源分配方法示意图,参见图 6,聚合前的分支载波的带宽均为 10M, $P = 3$ ,分支载波聚合后的带宽为 20M,将  $P$  选为 6(分支载波分配粒度的最小公倍数)。由于分支载波聚合后的粒度正好是分支载波的粒度的倍数,不会出现如图 1 那种 LTE-A 系统的一个资源块组涉及了 LTE 系统中的两个资源块组且并没有与两个资源块组完全对齐,造成的资源浪费及不兼容问题。或者,再例如,当分载波的分配粒度分别为 3 和 4 时,可以将聚合载波的分配粒度选择为 12。同时,如果觉得以某一倍数的关系调用的资源块数较大,可以选择倍数的一半,若觉得 12 较大,可以选为 6。这样同时调度两个 LTE-A 的终端可以与 LTE 系统的终端的资源对齐,实现一定程度的兼容。图 7 为本发明第七实施例的资源分配方法示意图,参见图 7,分支载波的带宽分别为 15M 及 5M,聚合后的带宽为 20M。在 LTE 系统中,相应的粒度分别为  $P = 4$  及  $P = 2$ 。在 LTE-A 系统中将  $P$  选为 4。

[0061] 上述选择 LTE-A 系统的资源分配粒度只是示例,不限于上述选择方案,只要考虑各分支载波在 LTE 系统中的资源分配粒度,根据各分支载波在 LTE 系统中的资源分配粒度得到 LTE-A 系统中聚合后的带宽的资源分配粒度均在本实施例的覆盖范围内。

[0062] 上述根据各分支载波的资源分配粒度,而不是如现有技术那样只根据聚合后的带宽确定载波聚合后的带宽的分配粒度,可以实现 LTE 终端与 LTE-A 终端的兼容,避免资源浪费。

[0063] 步骤 53:网络设备根据 LTE-A 系统中各分支载波聚合后的带宽的资源分配粒度,指示 LTE-A 系统中各分支载波聚合后的资源分配情况。

[0064] 在指示资源分配情况时,可以采用 RA type0 方式,也可以采用 RA type1 方式。

[0065] 对于 RA type0 方式:图 8 为本发明第八实施例的资源分配方法示意图。参见图 8, 当将整个载波聚合后的带宽内所有 RB 进行顺序编号并依次按照资源分配粒度划分资源块组 (RBG) 时, 很可能出现前一个分支载波中的剩余资源块与后一个分支载波中前面几个资源块组成一个资源块组。使本该 LTE 终端的 2 个资源块组对应 LTE-A 终端 1 个资源块组, 对应了 LTE-A 终端的 2 个资源块, 出现资源冲突, 破坏了兼容性。为此, 当分支载波包含的资源块的个数不为载波聚合后的带宽的资源分配粒度的整数倍时, 将分支载波中按照聚合后的资源分配粒度分配后剩余的资源块另组成一个资源块组 (参见图 8 的填充的资源块)。其中, 当一 RBG 中的 RB 的个数为聚合后的资源分配粒度时, 该 RBG 为足额 RBG, 上述剩余的 RB 组成的 RBG 为不足额 RBG。在资源指配信令中, 每个资源块组用一个比特指示, 此时, 由于分支载波剩余的资源块单独组成一个资源块组, 比以聚合后的带宽为整体分配资源时增加一个比特 (从图 8 可以看出, 第三个中的资源块组的个数比第二个中的资源组的个数多一个)。或者, 为了保证资源分配占用相同的比特数, 将按照聚合后的资源分配粒度得到的资源块组 (足额 RBG) 分别用一个比特指示, 将各分支载波中剩余的资源块组成的资源块组 (不足额 RBG) 用一个比特联合指示, 即第三个中未填充的资源块组分别用一个比特指示, 将两个填充的资源块组联合用一个比特指示。图 9 为本发明第九实施例的资源分配方法示意图, 本实施例与图 8 所示的实施例不同的是本实施例以分支载波分别为 15M 和 5M 为例。其余原理与图 8 相同, 不再赘述。

[0066] 上述采用 RA type0 方式进行调度, 可以以资源块组大小为单位进行集中调度。为了提高频率分集增益, 可以采用 RA type1 方式。

[0067] 对于 RA type1 方式: 由于采用上述公倍数的粒度选择方法后, LTE-A 系统中的资源分配粒度较 LTE 系统中的资源分配粒度大, 也可能出现第一实施例中的问题。因此, 对于 RA type1 方式, 也可以如第一实施例中的, 将 RBG 分为个数小于 LTE-A 系统中的分配粒度的 RBG 子集, 还可以用一个比特指示每个子集中的多个 RB。具体实现方式可以参见第一实施例, 在此不再赘述。

[0068] 上述实现了网络侧对终端的资源分配, 为了使终端准确地调度资源, 需要将资源分配粒度发送给终端, 资源分配粒度是采用上述根据各分支载波的情况获得的各分支载波聚合后的带宽的资源分配粒度。可以采用如下方式下发资源分配粒度。

[0069] 方式一: 采用静态的方式。例如, 网络侧通过协议以固定表格的方式静态配置终端的资源分配粒度。

[0070] 方式二: 采用半静态的方式。例如, 网络侧通过高层信令根据终端的业务情况半静态地改变资源分配粒度, 并将改变后的资源分配粒度通过单播或广播的方式发送给终端。

[0071] 第一实施例是根据各分支载波在 LTE 系统中的资源分配粒度, 独立地分别获得各分支载波在 LTE-A 系统中的资源分配粒度。本实施例是根据各分支载波在 LTE 系统中的资源分配粒度, 统一确定在 LTE-A 系统中的载波聚合后的带宽的资源分配粒度。对于第一实施例, 由于各分支载波是分别独立处理的, 因此, 对于 RA type0 方式, 可以采用现有技术实现; 但是, 由于第一实施例中 LTE-A 系统相比于 LTE 系统增大了资源分配粒度, 为了保证频率分集增益, 对于 RA type1 方式, 在 LTE-A 系统中, 将 RBG 子集的个数选为小于资源分配粒度, 进一步地, 还可以用一个比特联合指示一个 RBG 子集中的多个 RB。

[0072] 本实施例根据 LTE 系统中各分支载波的资源分配粒度, 统一确定在 LTE-A 系统中

的载波聚合后的带宽的资源分配粒度。可以保证 LTE-A 和 LTE 终端的兼容,节省资源。通过考虑分支载波的边界可以避免资源冲突。通过将资源块组分为小于分配粒度的资源块组子集可以提高频率分集增益。通过一个比特指示更多的资源块,可以进一步地提高频率分集增益。

[0073] 本领域普通技术人员可以理解:实现上述方法实施例的全部或部分步骤可以通过程序指令相关的硬件来完成,前述的程序可以存储于一计算机可读取存储介质中,该程序在执行时,执行包括上述方法实施例的步骤;而前述的存储介质包括:ROM、RAM、磁碟或者光盘等各种可以存储程序代码的介质。

[0074] 对应上述方法,本发明实施例提供了一种网络设备,包括:资源确定单元,用于根据获取到的后向兼容系统中的资源分配粒度,确定演进系统中的资源分配粒度;资源分配单元,用于根据所述资源确定单元所确定的演进系统中的资源分配粒度,指示演进系统中的资源分配情况。本实施例根据分支载波在后向兼容系统中的分配粒度得到在演进系统中的分配粒度,由于演进系统中的分配粒度是考虑了后向兼容系统中的分配粒度,而非现有技术只根据演进系统中的带宽,可以避免现有技术由于没有考虑后向兼容系统中的分配粒度造成的资源冲突问题,可以保证对 LTE-A 终端和 LTE 终端的兼容。下面对上述设备进行详细描述,具体地,上述的资源确定单元包括下述的获取模块和确定模块,上述的资源分配单元包括下述的指示模块:

[0075] 图 10 为本发明第十实施例的网络设备的结构示意图,包括获取模块 101、确定模块 102 和指示模块 103。获取模块 101 用于获取后向兼容系统中,各分支载波的带宽的资源分配粒度;确定模块 102 用于根据获取模块 101 得到的后向兼容系统中各分支载波的带宽的资源分配粒度,确定演进系统中,各分支载波的带宽的资源分配粒度;指示模块 103 用于根据确定模块 102 得到的演进系统中各分支载波的带宽的资源分配粒度,指示演进系统中,各分支载波的资源分配情况。或者,获取模块 101 用于获取后向兼容系统中,分支载波的带宽的资源分配粒度;确定模块 102 用于根据获取模块 101 得到的后向兼容系统中分支载波的带宽的资源分配粒度,确定演进系统中,分支载波聚合后的带宽的资源分配粒度;指示模块 103 用于根据确定模块 102 得到的演进系统中分支载波聚合后的带宽的资源分配粒度,指示演进系统中,分支载波聚合后的资源分配情况。

[0076] 具体地,确定模块 102 具体用于根据后向兼容系统中所有分支载波的带宽的资源分配粒度,确定演进系统中,分支载波聚合后的带宽的资源分配粒度;或者,在所有分支载波中确定配置给终端的分支载波,根据配置给终端的分支载波的带宽的资源分配粒度,确定演进系统中,分支载波聚合后的带宽的资源分配粒度。此时,指示模块 103 具体用于根据演进系统中分支载波聚合后的带宽的资源分配粒度,将分支载波的带宽包括的资源块分为一个或多个资源块组;每个资源块组用一个比特指示;或者,每个足额的资源块组用一个比特指示,所有分支载波内不足额的资源块组联合用一个比特指示;或者,指示模块 103 具体用于根据演进系统中分支载波聚合后的带宽的资源分配粒度,将各分支载波的带宽包括的资源块分为一个或多个资源块组;将所有分支载波的带宽包括的资源块组分为  $N$  个资源块组子集,且  $N = \frac{P}{2^k}$ ;其中,  $N$  为资源块组子集的个数,  $P$  为演进系统中分支载波聚合后的带宽的资源分配粒度,  $k$  为大于等于 0 的整数;采用比特映射的方式指示各资源块组子集中资

源块的分配情况。

[0077] 或者,确定模块 102 具体用于通过公式  $P = k \times P_1$ , 或者,  $P = 0.5 \times k \times P_1$ , 根据后向兼容系统中各分支载波的带宽的资源分配粒度, 确定演进系统中, 各分支载波的带宽的资源分配粒度; 其中,  $P_1$  为后向兼容系统中一个分支载波的带宽的资源分配粒度,  $P$  为演进系统中该分支载波的带宽的资源分配粒度,  $k$  为大于等于 2 的整数, 对于  $P = 0.5 \times k \times P_1$  需要满足  $(k \times P_1) \bmod 2 = 0$ 。此时, 指示模块 103 具体用于根据演进系统中一个分支载波的带宽的资源分配粒度, 将演进系统中该分支载波的带宽包括的资源块分为一个或多个资源块组; 将所述资源块组分为  $N$  个资源块组子集, 且  $N = \frac{P}{2^k}$ ; 其中,  $N$  为资源块组子集的个数,  $P$  为演进系统中该分支载波的带宽的分配粒度,  $k$  为大于等于 0 的整数; 采用比特映射的方式指示各资源块组子集中资源块的分配情况。

[0078] 本实施例根据分支载波的在 LTE 系统中的资源分配粒度独立或统一得到 LTE-A 系统中的聚合后的资源分配粒度, 可以很好地考虑分支载波的情况, 实现 LTE-A 终端与 LTE 终端的兼容, 避免资源浪费。

[0079] 图 11 为本发明第十一实施例的网络设备的结构示意图, 包括获取模块 111、确定模块 112 和指示模块 113, 还包括通知模块 114。获取模块 111 用于获取后向兼容系统中, 各分支载波的带宽的资源分配粒度; 确定模块 112 用于根据获取模块 111 得到的后向兼容系统中各分支载波的带宽的资源分配粒度, 确定演进系统中, 各分支载波的带宽的资源分配粒度; 指示模块 113 用于根据确定模块 112 得到的演进系统中各分支载波的带宽的资源分配粒度, 指示演进系统中, 各分支载波的资源分配情况; 通知模块 114 用于通过静态配置的方式, 或者单播的方式, 或者组播的方式, 将确定模块得到的演进系统中各分支载波的带宽的资源分配粒度发送给终端。

[0080] 或者, 获取模块 111 用于获取后向兼容系统中, 各分支载波的带宽的资源分配粒度; 确定模块 112 用于根据获取模块 111 得到的后向兼容系统中各分支载波的带宽的资源分配粒度, 确定演进系统中, 各分支载波聚合后的带宽的资源分配粒度; 指示模块 113 用于根据确定模块 112 得到的演进系统中各分支载波聚合后的带宽的资源分配粒度, 指示演进系统中, 各分支载波聚合后的资源分配情况; 通知模块 114 用于通过静态配置的方式, 或者单播的方式, 或者组播的方式, 将确定模块得到的演进系统中各分支载波聚合后的带宽的资源分配粒度发送给终端。本实施例不仅可以实现第九实施例的技术效果, 还可以针对终端静态设置分配粒度, 或者, 通过单播发送针对某一终端的分配粒度, 或者, 通过组播发送针对所有终端的分配粒度。

[0081] 进一步地, 本发明实施例还提供了一种无线系统, 包括网络设备, 用于根据后向兼容系统中分支载波的带宽的资源分配粒度, 确定演进系统中, 分支载波聚合后的带宽的资源分配粒度, 指示演进系统中, 分支载波聚合后的资源分配情况; 或者, 用于根据后向兼容系统中各分支载波的带宽的资源分配粒度, 确定演进系统中, 各分支载波的带宽的资源分配粒度, 指示演进系统中, 各分支载波的资源分配情况。具体的网络设备可参见图 10、图 11 所示的网络设备。

[0082] 本实施例根据分支载波的在 LTE 系统中的资源分配粒度独立或统一得到 LTE-A 系统中的聚合后的资源分配粒度, 可以很好地考虑分支载波的情况, 实现 LTE-A 终端与 LTE 终

端的兼容,避免资源浪费。

[0083] 最后应说明的是:以上实施例仅用以说明本发明的技术方案而非对其进行限制,尽管参照较佳实施例对本发明进行了详细的说明,本领域的普通技术人员应当理解:其依然可以对本发明的技术方案进行修改或者等同替换,而这些修改或者等同替换亦不能使修改后的技术方案脱离本发明技术方案的精神和范围。





图 1



图 2

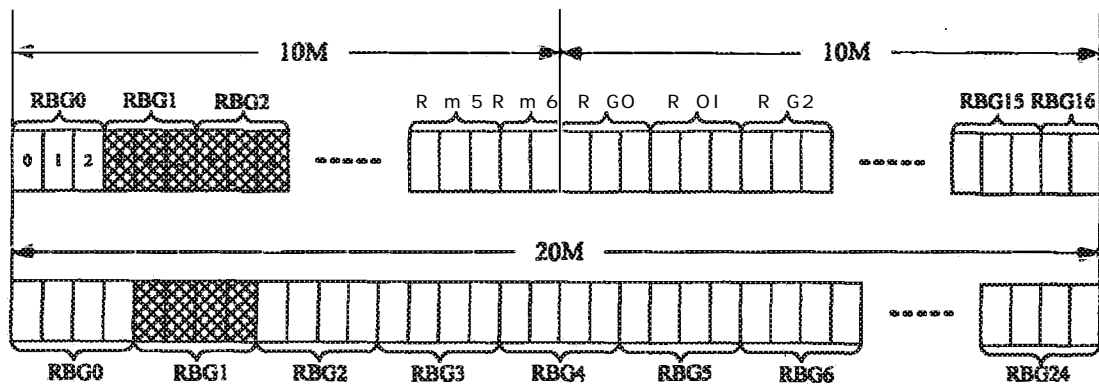

图 3

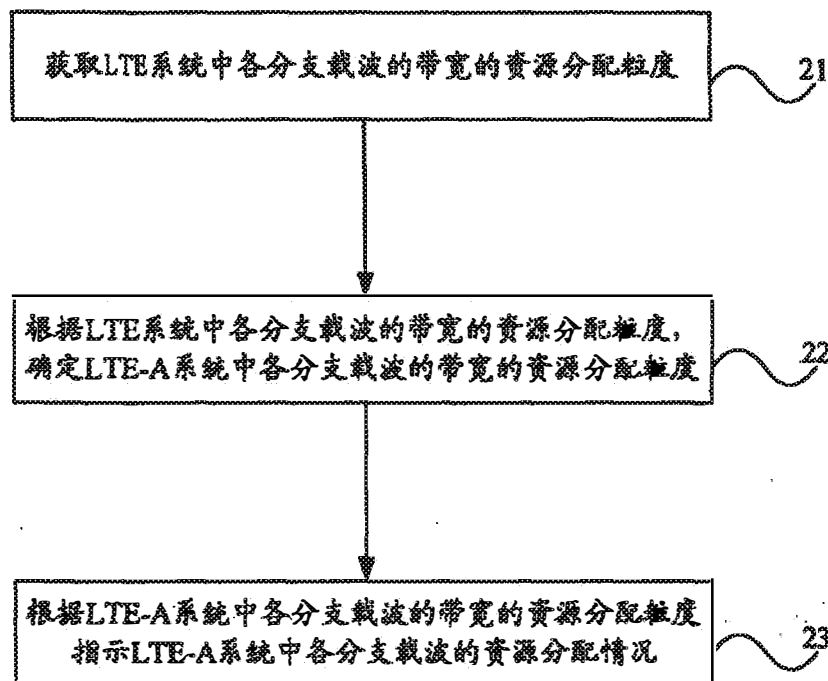

图 4

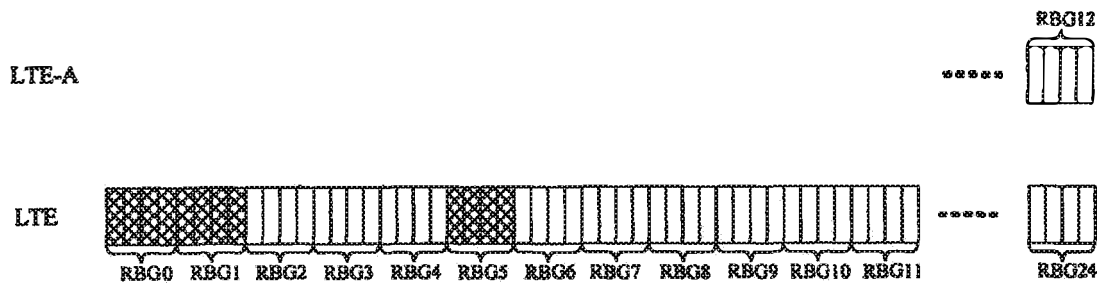

图 5

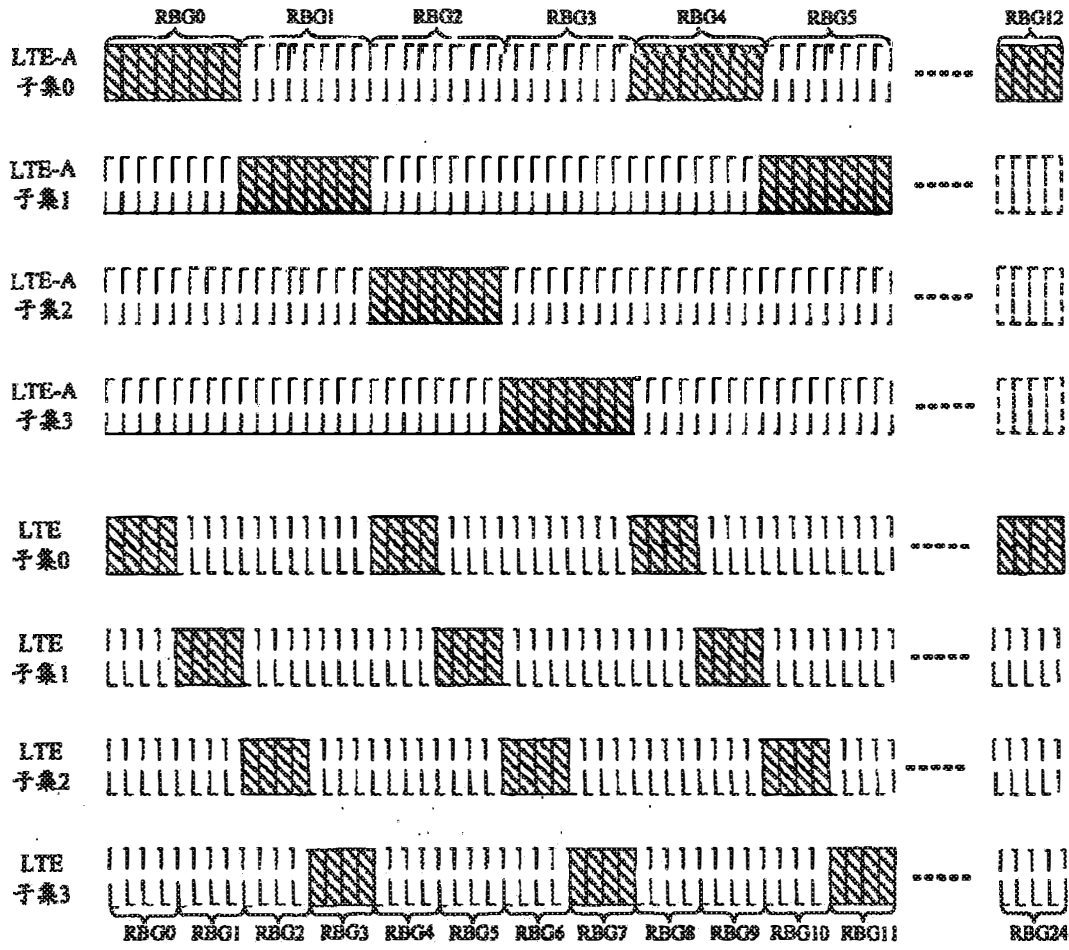

图 6

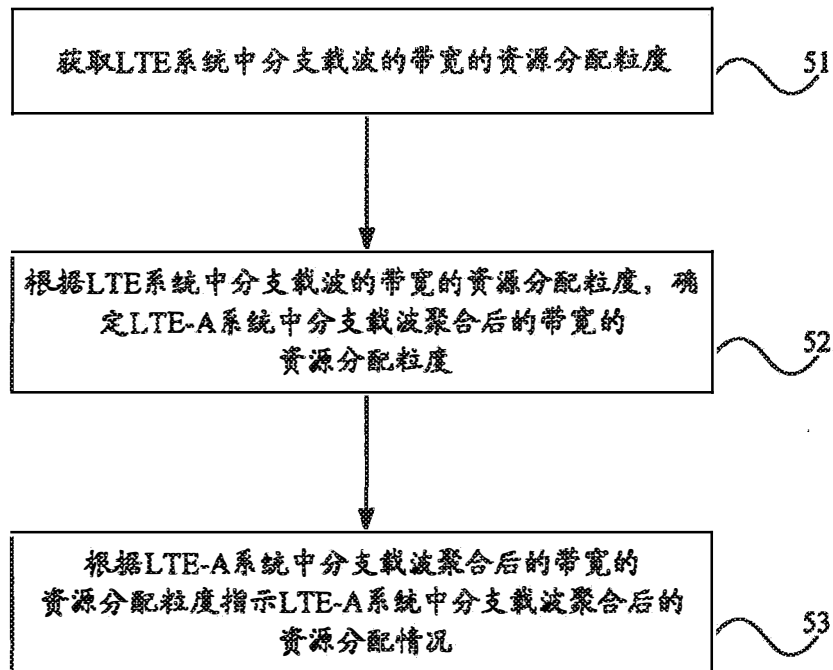

图 7

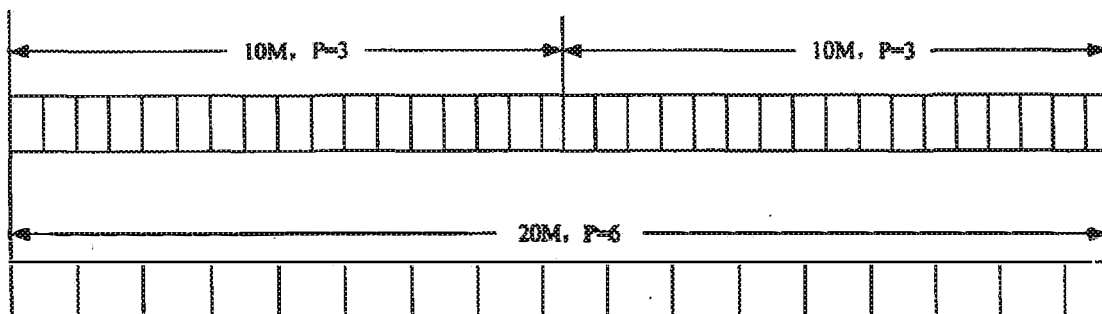

图 8

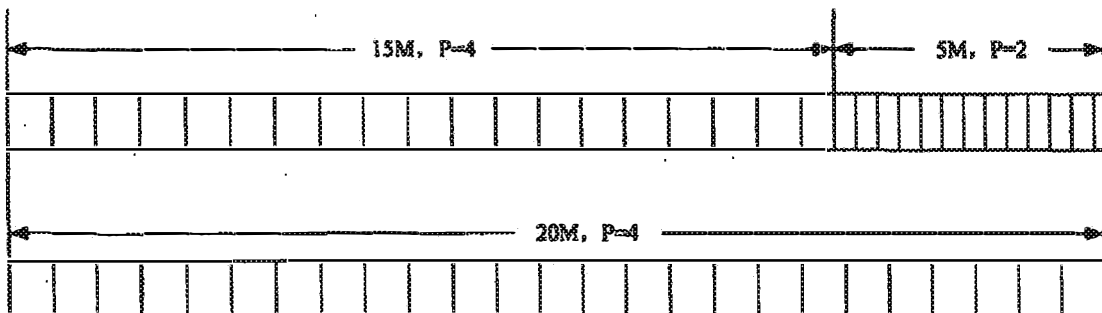

图 9

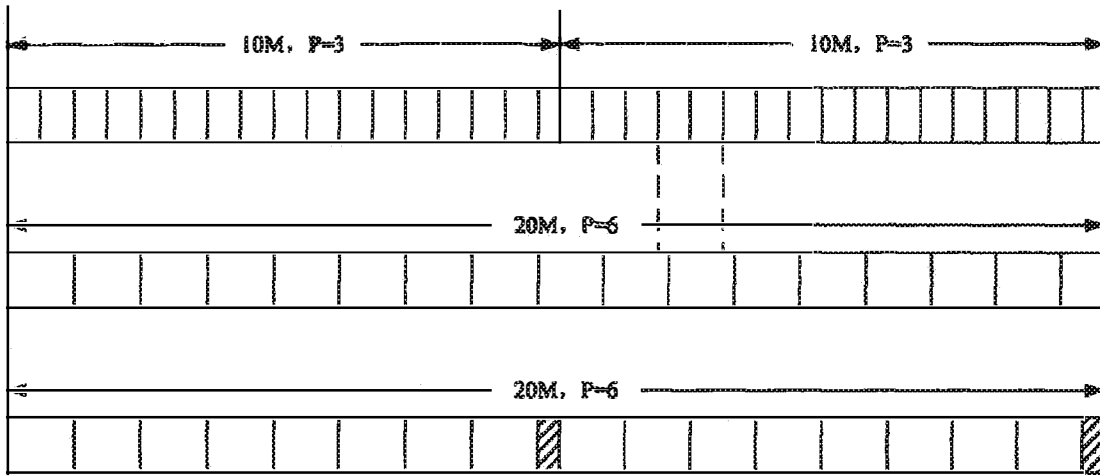

图 10

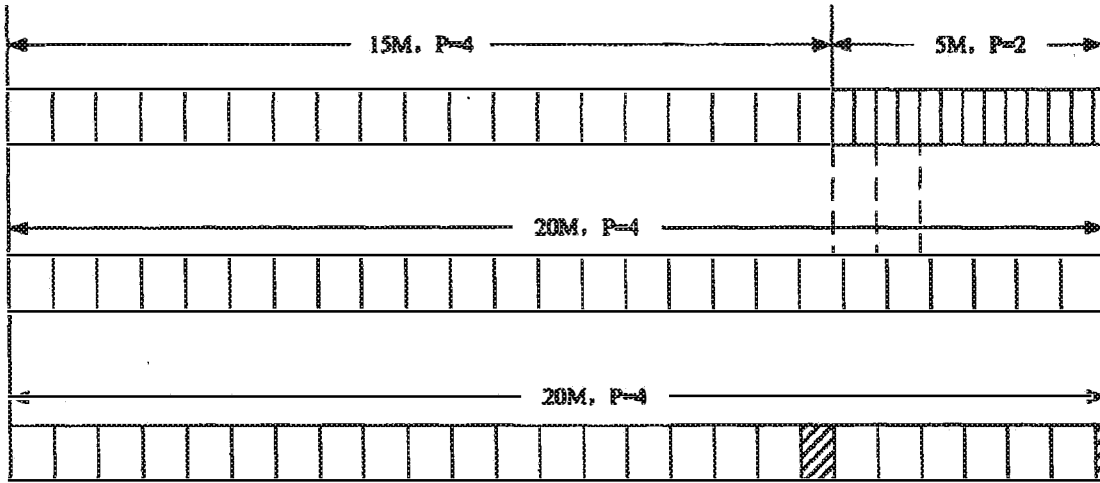

图 11

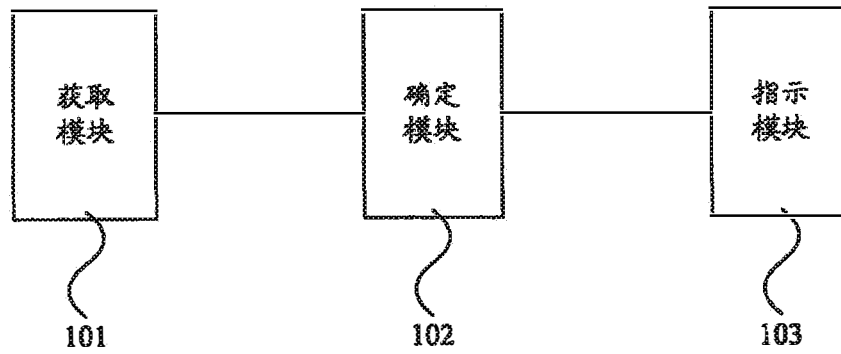

Espacenet

**Bibliographic data: CN101765208 (A) — 2010-06-30**
**Method for distributing resources, network equipment and wireless system**

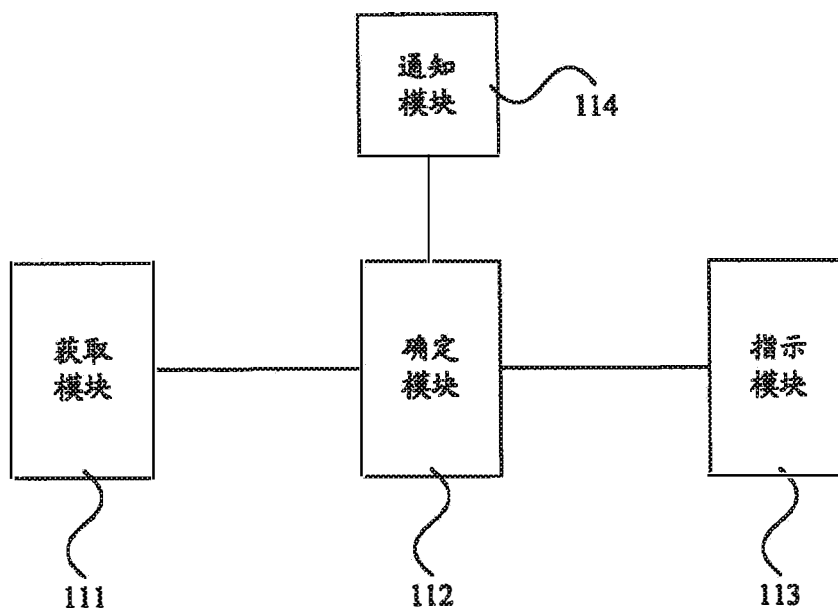
**Inventor(s):** LIXIA XUE ± (XUE LIXIA)

**Applicant(s):** HUAWEI TECH CO LTD ± (HUAWEI TECHNOLOGIES CO., LTD)

**Classification:** - international: *H04W28/12; H04W72/04*  
- cooperative:

**Application number:** CN20081188931 20081226

**Priority number(s):** CN20081188931 20081226

**Also published as:** CN101765208 (B)

**Abstract of CN101765208 (A)**

The invention discloses a method for distributing resources, network equipment and a wireless system. The method comprises the following steps of: confirming resource distributing granularity in an evolution system according to the resource distributing granularity of an obtained backward compatible system; and indicating the resource distributing condition in the evolution system according to the resource distributing granularity in the evolution system.; The resource distributing granularity of bandwidth after branch carriers are polymerized in the evolution system can be confirmed according to the resource distributing granularity of the bandwidth of the branch carriers in the backward compatible system so as to indicate the resource distributing condition after the branch carriers are polymerized in the evolution system or the resource distributing granularity of bandwidth of all branch carriers in the evolution system can be confirmed according to the resource distributing granularity of the bandwidth of all branch carriers in the backward compatible system so as to indicate the resource distributing condition of all branch carriers in the evolution system.; By the embodiment of the invention, the compatibility of the resource distribution of an LTE-A terminal and an LTE terminal can be maintained, and the cost of a resource distributing signaling is saved.

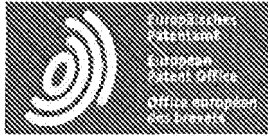

# Patent Translate

Powered by EPO and Google

## Notice

This translation is machine-generated. It cannot be guaranteed that it is intelligible, accurate, complete, reliable or fit for specific purposes. Critical decisions, such as commercially relevant or financial decisions, should not be based on machine-translation output.

## DESCRIPTION CN101765208

The present invention discloses a method of resource allocation, network equipment and wireless systems. The method comprising administering to a compatible system resource allocation size to determine the evolution of resources in the system according to the particle size distribution after acquired; according to the evolution of the particle size distribution of resources in the system, indicating the evolution of the system of allocation of resources. After the allocation of resources according to the size of the branch system compatible carrier bandwidth, determine resource allocation granularity bandwidth evolution system branch carrier after polymerization, thereby indicating the allocation of resources in the branch evolution system carrier after polymerization. Alternatively, you can also according to the resource allocation granularity compatible system each branch carrier bandwidth, determine resource allocation granularity evolution system each branch carrier bandwidth, thus indicating a resource allocation system in the evolution of the respective branch carriers. Example maintain compatibility with LTE terminals and LTE-A terminal resource allocation, resource allocation and saving the overhead of signaling by the present invention.

The method of resource allocation, network equipment and wireless systems

### TECHNICAL FIELD

The present invention relates to wireless communication technologies, particularly to a method of resource allocation, network equipment and wireless systems.

## Background technique

The exact size of the system bandwidth in the LTE (Long Term Evolved, LTE) system, the network will be notified through the downlink broadcast signaling used within the network to each terminal, then the terminal further based on the resource block included in a system bandwidth (Resource block, RB) determining the number of resource allocation granularity some resource allocation method, for example, downlink resource allocation method of 0 and 1 (resource allocation type 0 / 1, RA type 0/1) particle size. Thereafter, the network will be transmitted through a specific resource allocation signaling resource allocation information to the terminal needs to transmit data, the terminal position according to the time-frequency resources the resource allocation signaling information received to determine the specific distribution network, and in the corresponding time-frequency resources send or receive data location, data transmission and communication networks and terminals.

In the evolution of the LTE system (LTE-A), in order to support greater bandwidth, one possible way is to multiple branches carrier aggregation, resource upcoming multiple branches carriers simultaneously dispatched to a terminal use. A plurality of spectrum occupied by the branch carriers may be continuous or non-continuous, the bandwidth of each branch carrier may be the same or different, each branch carrier may be a carrier compatible with LTE terminals, it may simply be a support LTE-A carrier terminal, the LTE terminal in the LTE-A carrier for data transmission and can not communicate. Existing LTE-A technology resource allocation is based on the particle size distribution of the entire system bandwidth of all branches of carrier aggregation are determined by resources.

The inventors found that the prior art at least the following problems in the process of carrying out the invention: the existing LTE-A technology resource allocation resource allocation granularity is determined based on the entire system bandwidth of all branches of the carrier after polymerization, this allocation will result in LTE technology not backward compatible -A system vulnerabilities and waste of resources.

## SUMMARY

The present invention is to provide a resource allocation method, network equipment and wireless systems, so that LTE-A resource allocation techniques to be able to post compatible.

Embodiment of the invention provides a method for resource allocation, comprising:



Particle size distribution of resources in the system to be compatible in accordance with acquired after determining the evolution of the system of resource allocation granularity;

According to the evolution of the system of resource allocation size, indicating the evolution of the system of allocation of resources.

Embodiment of the invention there is provided a network device, comprising:

Resource determination unit for the particle size distribution of resources in the system to be compatible in accordance with acquired after determining the evolution of the system of resource allocation granularity;

Resource allocation means for determining resource allocation based on the unit size determined by the evolution of resources in the system, indicating the evolution of the system of allocation of resources.

The embodiment provides a wireless system of the present invention is characterized in that it comprises:

Network equipment for after-compatible system according to the branch of the carrier bandwidth granularity of resource allocation, to determine the evolution of the system, bandwidth resources branch carrier particle size distribution after polymerization, indicating the LTE system, resource allocation branch carrier after polymerization; or, according to the resource allocation size after the system is compatible with the bandwidth of each branch of the carrier to determine the evolution of the system, each branch carrier resource allocation granularity bandwidth indicates the evolution of the system, the distribution of resources each branch carrier.

By the technical solutions found, embodiments of the present invention obtained in the evolution of the system allocation granularity according to the branch carrier in a backward-compatible system allocation granularity cases, after due to the evolution of the system allocation granularity is considered the size to a compatible system distribution, according to the prior art, not only the evolution of the system bandwidth, resource conflicts can be avoided in the prior art not considered due to the after-compatible system allocation granularity caused can ensure LTE-a terminal and LTE compatible terminals.

BRIEF DESCRIPTION

Figure 1 is a schematic view of conventional resource allocation method;

Figure 2 is a schematic process flow schematic diagram of a first embodiment;

Figure 3 of the present invention the resource allocation method of the second embodiment of the schematic;

Figure 4 of the present invention the resource allocation method of the fourth embodiment is a schematic;

Figure 5 is a process flow according to the fifth embodiment of the schematic;

Figure 6 of the present invention the sixth embodiment of the resource allocation method schematic;

Figure 7 is a resource allocation method according to the seventh embodiment is a schematic;

Figure 8 of the present invention the resource allocation method of the eighth embodiment schematic view;

Figure 9 is a resource allocation method according to the ninth embodiment schematic view;

Figure 10 a schematic view of a tenth embodiment of the present invention, the structure of an example of a network device;

11 a schematic diagram of the structure of the present invention, a network device in the eleventh embodiment.

detailed description

By the following figures and examples of technical solutions of the present invention is described in further detail do.

In the LTE downlink resource allocation system, each time a transmission unit corresponding to the end-user resource allocation signaling bearer resource allocation type and corresponding resource allocation information, divided into RA type0, RA type1, RA type2. RA type0 with bit map (a Bitmap) indication of the resource block group (RBG) allocation case where each bit indicates whether or not a corresponding RBG is assigned, that is, a minimum size of RBG resource allocation, each resource block group (RBGs) includes a plurality of resource blocks (resource block, RB). The number of resource blocks included in each resource block group by the total number of system bandwidth RB includes all decisions that RBG size is a function of system bandwidth contains the number of RB's. Different sizes of resource block groups corresponding to a different system bandwidth, i.e., the minimum granularity of the resource allocation is different. See Table 1 for the relationship between the system bandwidth includes a resource block number and the size of P NRBDL.

Table 1

If the number of resource blocks included in the system bandwidth NRBDL, the size (i.e., size) of each resource block group is P, the RA type0 for distribution, in the resource allocation signaling requires  $\langle \text{img class = "EMIRef" id = "102441405-ifd0001" />$  Bits to indicate a specific allocation of resources. Where,  $\langle \text{img class = "EMIRef" id = "102441405-ifd0002" />$  Expressed rounded up.

In the same case the system bandwidth, RA type1 and RA type0 resource-allocation signaling bits is the same, but also the use of bitmap (bitmap) mode indication. In order to distinguish the specific type of resource allocation is RA type 0 or RA type 1, in the resource allocation signaling in a bit of information to distinguish. RA type 1 according to the system bandwidth of the resource block is divided into groups of P resource block group subsets, for example, the number of resource blocks RA type0 each resource block group comprising of P. Therefore need  $\langle \text{img class = "EMIRef" id = "102441405-ifd0003" />$  Bit indicates the end user is scheduled resources which resource block group subset. To be able to instruct as many resources, but also need a bit used to indicate the direction of the initial resource allocation, that is, from the left or right directions resource allocation. Therefore, the number of bits used to indicate the resource blocks scheduled to  $\langle \text{img class = "EMIRef" id = "102441405-ifd0004" />$  Corresponding to each bit may indicate whether the sub-groups of resource blocks RB set is called, and scheduling of resource allocation is limited to only the end user can be a subset.

When extending from the LTE system to the next generation of the LTE-A system, the existing resource allocation method is the direct determination of resource allocation based on the bandwidth granularity carrier after polymerization, regardless of the specific size of each branch carrier resource allocation for LTE users. Happening. See Table 2 for the number of RB included in the bandwidth of the carrier after polymerization, the relationship between the number of bits of resource allocation and resource allocation granularity carriers needed after polymerization of.

Table 2

Figure 1 is a schematic view of conventional resource allocation method, the two branches of the carrier before the carrier aggregation are 10M (according to the prior art to obtain the resource block at this time include the number is 50), Table 1 can be learned by each branch carrier the resource allocation granularity are 3, i.e., each resource block groups each branch carrier from three resource blocks, so that, for both branches carriers LTE user resource assignment (RA type0) particle size of 3; carrier the bandwidth is 20M after the polymerization (the number of resource blocks included in 100), the resource allocation by table 2 that after the carrier aggregation size is 4, i.e., within the bandwidth of each RBG after polymerization by the 4 RB composition. As can be seen from Figure 1, when the carrier RBG1 after polymerization (corresponding to RB4 ~ RB7) allocated to LTE-A terminal, the corresponding branch carriers RBG1 RBG2 and can no longer be assigned to units of RBG LTE terminals, namely in the corresponding branch carriers can not be used RA type 0 method RB3 will RBG1 and RBG2 allocated to LTE terminals, such correspondence has not been assigned to go out and RB8 not allocated in this way to LTE terminals, which caused the branch carrier RBG1, RBG2 waste of resources in both ends of the RB, or the scheduler to coordinate inter RA type 0 resource allocation method will RB3 and RB8 are assigned to the terminal, which can be RB3 and RB8 resources utilized, but will increase the complexity of the scheduler.

For this reason, not only to determine the bandwidth of aggregated carriers resource allocation granularity, combined with the specific needs of each branch carrier Allotments granularity after the carrier aggregation LTE-A system for allocation granularity LTE terminals, to ensure that the LTE and LTE- a resource allocation method is compatible with the system, to avoid waste of resources. Accordingly, embodiments of the present invention provides a resource allocation method, comprising: a backwards compatible system resource allocation size, determined according to the evolution of the system after obtaining a resource allocation size; particle size distribution according to the evolution of resources in the system, indicating that evolution system resource allocation. In this embodiment, the branch carrier obtained after the evolution of the system in the particle size distribution to the particle size distribution of a compatible system, since the evolution of the system is the particle size distribution of the particle size distribution after consideration of the compatibility of the system, rather than according to the prior art only in accordance with Evolution of the system bandwidth, the prior art can be avoided due to resource issues in post-conflict does not consider to be compatible system allocation granularity caused can ensure LTE-a terminal and LTE compatible terminals. The following detailed description of the method described above:

The method of the present invention, a flow chart 2 a schematic view of a first embodiment, comprising:

Backward compatible with the system, each branch carrier bandwidth resource allocation size after the network

equipment (such as a base station) get: Step 21.

The following after-compatible system to the LTE system, an evolved system for the LTE-A system, for example.

Step 22: The network equipment according to the resource allocation granularity LTE system bandwidth of each branch carrier, determine a resource allocation granularity LTE-A system, each branch carrier bandwidth.

The specific calculation formula:  $P = k \times P1$ , or,  $P = 0.5 \times k \times P1$  (case requires  $(k \times P1) \bmod 2 = 0$ ); wherein,  $P1$  is the resource allocation in a LTE systems bandwidth branch carrier particle size,  $P$  is the LTE-a system resource allocation granularity of the branch carrier bandwidth.  $k$  is an integer of 2. For example, two carriers are branches 10M (the LTE system, resource allocation granularity corresponding to 3) and 20M (LTE system, resource allocation granularity corresponding to 4), in the LTE-A system, from the branch of the carrier 10M resource allocation granularity preferably 3,6,9, etc., can be a resource allocation granularity 20M preferably 4,6,8 branch carriers and the like.

Step 23: The network equipment according to the particle size distribution of LTE-A system, each branch carrier bandwidth resources, indicating LTE-A system, the distribution of resources each branch carrier.

Specifically, when the resource allocation, RA type0 mode can also be used RA type1 mode. For RA type0 manner, in each branch carrier, in the LTE-A system in accordance with the particle size of the branch carrier, will be composed of a plurality of RBG RB, with each bit indicating whether a corresponding RBG is allocated.

However, the RA type1 way, since the above-described particle size selection method after multiple, LTE-A system is a resource allocation granularity than the resource allocation in the LTE system a large grain size (usually a multiple of the relationship). For example, Figure 3 of the present invention the resource allocation method of the second embodiment of FIG. Referring to Figure 3, with a branch carrier 20M for example, the bandwidth includes 100 resource blocks. For LTE terminals, the particle size distribution of 4, the number of bits occupied by the resource allocation 25 for LTE-A terminals, the particle size distribution is 8, the number of bits occupied by the resource allocation 13. As can be seen from Figure 3, when given a LTE-A terminal RBG0 allocation for LTE-A terminal, with corresponding RBG0 for LTE terminals, RBG1 can not be allocated to LTE terminal; when RBG5 allocation for LTE terminals to a LTE terminal, corresponding RBG2 for LTE-a terminal can no longer use the RA type0 allocated to LTE-a terminal. But you can use other means, such as RA type1 manner allocated to LTE-A terminal in the same way or assigned to other LTE terminals, using different allocation resource allocation, resource allocation method can be more flexible and better to maintain compatibility with LTE terminals and LTE-a terminals.

For RA type1 way, if still will RBG resource allocation granularity into the same number of RBG subset, it may indicate that the number of bits and not well enough to obtain a frequency diversity gain problems. Because RA type1 and RA type0 occupy the same number of bits, the LTE-A terminals, due to its particle size distribution is 8, then the number of resource block groups corresponding subset for 8, additional bits indicating the need for a direction (left or indication from the resource block), since the number of resources in this case is 13 bits, only the 9 bits is used to indicate whether or not the subset of the resource block allocation can be seen from Figure 3, only nine bits indicating a resource block group the eight resource blocks that is another resource block groups in a resource block. This does not make the frequency subset of all resource blocks are covered, but also makes the indicated resource blocks are concentrated, can not get good data transmission diversity gain.

To this end, the RA type1: the branch carrier groups of resource blocks are divided into N resource block group subset, and `<img class = "EMIRef" id = "102441405-afd0005" />` Where N is the number of resource block group subset, P is the LTE-A system, the particle size distribution of the branch carrier bandwidth, k is an integer of 0; with each bit indicating resource block group subset allocation of resource blocks Happening. In particular, FIG. 4 of the present invention the resource allocation method of the fourth embodiment of FIG. Referring to Figure 4, the LTE-A P = 8 as an example, the resource block is divided into four groups subset of resource block groups (k = 1). The first sub-set includes RBG0 LTE-A's, RBG4, RBG8, RBG12, the second subset comprising RBG1 LTE-A's, RBG5, RBG9, third subset including the LTE-A RBG2, RBG6, RBG10, fourth including LTE-a subset of RBG3, RBG7, RBG11. For LTE terminals, the prior art can still be divided into four subsets.

For LTE-A terminal at RA type1 divided into four subsets, this requires two bits indicating which subset in RB, with a bit indicates the direction (left or right directions), then also the remaining 10 bits, each bit indicates a subset of RB assignment or not. If at this time indicates that the resource is still insufficient dispersion, can be a bit indicating whether to allocate two resource blocks, this time can be covered in each subset allocation of resource blocks of at least three groups, more resources to achieve the indicated dispersion, increase frequency diversity gain. Of course, each bit may also indicate more resource blocks, each bit indicating when more resource blocks, the number of bits used for resource allocation in each subset is sufficient to indicate the allocation of resource blocks of all, it can be used for bits indicate the direction of savings for other purposes, e.g., for verification purposes.

In the above example in which a branch carrier, another branch of the processing flow of the carrier as described above, will not repeat them.

When using the above-described RA type1 manner, by dividing the resource block group size is smaller than the allocated resource block group subsets, increase the number of bits for indicating a resource block, so that more

and more of the resource blocks indicates the dispersion, when using a multi-bit indication when resource blocks may further indicate more and more distributed resource blocks, increase frequency diversity gain.

Allocation of resources described above to achieve a network-side resources allocated to the terminal, in order to enable the terminal to accurately schedule resources, resources need to be allocated granularity sent to the terminal, the resource allocation size is the use of the bandwidth of each branch carrier above depending on the circumstances of each branch carrier obtained granularity. Fair resource allocation granularity can use the following mode:

One way, static manner. For example, a fixed network side protocol table configured or resource allocation granularity terminal.

Option 2: semi-static way. For example, by changing the network side layer signaling terminal according to the service conditions of semi-statically allocated resource size and resource allocation size after the change to the terminal via unicast or broadcast.

This embodiment of the resource allocation granularity LTE system carrier each branch, each branch independently determined carriers in LTE-A system resource allocation granularity. Guaranteed compatible LTE-A and LTE terminals, saving resources. Divided by the resource block group size is smaller than the allocated resource block group subset may improve the frequency diversity gain. Indicating by a bit more resource blocks can be further improved frequency diversity gain.

5 is a flowchart of a method according to the fifth embodiment of a schematic diagram, comprising:

Step 51: The network device acquires the LTE system, the branch carrier bandwidth resource allocation granularity.

Step 52: The network equipment according to the resource allocation granularity branch carrier LTE system bandwidth, resource allocation granularity is determined bandwidth LTE-A carrier aggregation system after the branch.

Wherein, the network device according to the compatible systems to all branches of the carrier bandwidth resource allocation granularity, determining the LTE system, resource allocation granularity bandwidth branch

carrier after polymerization; or two network devices configured to the terminal in all branches carriers branch carrier, according to the resource allocation granularity configuration to the terminal branch of the bandwidth of the carrier, to determine the LTE system. resource allocation granularity bandwidth branch carrier after polymerization. For example, the carrier is a branched first carrier, the second carrier, a third carrier, the network device according to a first carrier, the second carrier and the third carrier in the LTE system determines the granularity of the resource allocation in the LTE-A system, after the carrier aggregation particle size distribution of resources; and to be the first carrier to determine the configuration of the UE, (for example, for UE for the first and second carriers), it is determined that the LTE- according to the first and second carriers in the LTE system resource allocation granularity resource allocation granularity a UE carrier after polymerization.

The specific calculation formula:  $P = \text{LCM}(P_1, \dots, P_n)$ , or,  $P = 0.5 \times \text{LCM}(P_1, \dots, P_n)$  (case requires  $\text{LCM}(P_1, \dots, P_n) \bmod 2 = 0$ ); wherein,  $P_1, \dots, P_n$  are the need for post-polymerization resource allocation granularity computing branch carrier (or carriers of all branches of the configuration to the terminal branch carrier) particle size distribution of resources in the LTE system,  $P$  is LTE-a system, each branch carrier resource allocation granularity bandwidth after polymerization,  $\text{LCM}(P_1, \dots, P_n)$  as  $P_1, \dots, P_n$  is the least common multiple. For example, FIG. 6 of the present invention the resource allocation method of the sixth embodiment is a schematic view, see Figure 6, the bandwidth of the carrier before the polymerization of the branches are 10M,  $P = 3$ , the bandwidth of the carrier after the polymerization of the branch 20M, preferably 6 to  $P$  (branch carrier particle size distribution of the least common multiple). Since the particle size of the carrier after the polymerization branched exact multiples of the granularity of a branch carrier, does not appear as shown in Figure 1 that a resource block group in the LTE-A system and LTE system involves two groups of resource blocks and not with the two resource block group perfectly aligned, resulting in a waste of resources and incompatibility issues. Alternatively, another example, when the sub-carrier allocation granularity 3 and 4, respectively, the polymerization can be selected for allocation granularity carrier 12. At the same time, if you think the relationship between the number of resource blocks to a large multiple of the call, you can select multiple half, if that 12 is large, can be selected as 6. Thus two scheduled simultaneously LTE-A terminal can be aligned with the LTE system resources for a terminal, a certain degree of compatibility. Figure 7 is a resource allocation method according to the seventh embodiment schematic view, see Fig. 7, the bandwidth of the carrier are branched and 15M 5M, after the polymerization of the bandwidth 20M. In the LTE system, the corresponding particle sizes of  $P = 4$  and  $P = 2$ . LTE-A system will be elected in  $P = 4$ .

The selection LTE-A system resource allocation granularity is merely exemplary, not limited to the above options, as far as the respective branch carriers in the LTE system resource allocation granularity, in accordance with each branch carrier in the LTE system resource allocation granularity obtained LTE-A system resource allocation granularity bandwidths after polymerization are within the coverage area of the present embodiment.

According to the above-described resource allocation granularity of each branch carrier, not only to determine that the bandwidth allocation granularity of the bandwidth of the carrier after polymerization after



polymerization according to the prior art, e.g., an LTE terminal can achieve compatibility with LTE-A terminals, and to avoid waste of resources.

Step 53: The network equipment according to the particle size distribution of LTE-A system in each branch after the carrier aggregation bandwidth resources, indicating the allocation of resources LTE-A system, each branch carrier after polymerization.

When indicating the allocation of resources, you can use RA type0 way, can also be used RA type1 way.

For RA type0 manner: 8 of the present invention the resource allocation method eighth embodiment of FIG. Referring to Figure 8, when within the bandwidth of the entire carrier aggregation after all RB carried out after a branch of the carrier before the sequence number and sequence of resource allocation granularity divided resource block group (RBC) by time, the likely emergence of a branch carrier remaining resource blocks resource blocks in the first few blocks of a resource group. So that the terminal 2 of the LTE resource block groups corresponding to an LTE-A terminal groups of resource blocks, resource blocks corresponding to the two terminals of LTE-A, a resource conflict, the destruction of compatibility. For this reason, when the number of resource blocks is not a branch of the bandwidth of the carrier containing the carrier after polymerization of an integral multiple of a resource allocation granularity, the branch carrier according to allocate the remaining resources after the allocation granularity of resource blocks after polymerization a composition of another resource block groups (see Figure 8 filled resource blocks). Wherein, when the number of RB's in a RBC resource allocation granularity after polymerization, this is full RBC RBC, RBC of RB said remaining composition is not full RBC. In the resource assignment signaling, each resource block group with a bit indication, this time, since the branch carrier remaining resource blocks form a separate resource block group, after an increase in bandwidth aggregation for the overall resource allocation when a bit (from FIG. 8 it can be seen, the number of resource blocks in the third group one more) than the number of the second resource group. Alternatively, resource block groups (RBCs full) in order to ensure the number of bits occupied by the same resource allocation, resource allocation according to the particle size obtained after polymerization are represented by a bit indicating the remaining sub-carriers of resource blocks of resource block group (not full RBC) with a joint bit indicates that a third of the unfilled resource block groups were treated with a bit indicating the two resource blocks filled with a set of conjoined bit instructions. Example 9 of the present invention the resource allocation method of the ninth embodiment schematic view, the embodiment shown in FIG. 8 embodiment is different from the present embodiment in divided carrier, respectively 15M and 5M example. Principle and the remaining 8 the same, not repeat them.

The above-described manner using RA type0 scheduling, resource block group size can be as a unit for centralized scheduling. In order to improve the frequency diversity gain can RA type1 mode.

For RA type1 way: As a result of the aforementioned common multiple size selection method after, LTE-A system of resource allocation granularity than the LTE system resource allocation large size, may also occur in patients with the problem of the first embodiment. Therefore, RA type1 way to be as in the first embodiment, the RBC is divided into less than the number of LTE-A system allocation granularity RBC subset, you can also use a bit indicating a plurality of RB in each subset. Specific implementation can be found in the first embodiment, it is not described here.

Above to achieve a network-side resources allocated to the terminal, in order to enable the terminal to accurately schedule resources need to be allocated size sent to the terminal resources, resource allocation granularity is the use of the bandwidth of each branch carrier aggregation according to the situation of each branch carrier obtained after the above resource allocation granularity. Hair resource allocation granularity can use the following mode.

One way: static manner. For example, a fixed network side protocol table configured or resource allocation granularity terminal.

Option 2: semi-static way. For example, by changing the network side layer signaling terminal according to the service conditions of semi-statically allocated resource size and resource allocation size after the change to the terminal via unicast or broadcast.

The first embodiment is based on the resource allocation size each branch carrier in the LTE system, the carriers obtained independently in each branch of the LTE-A system resource allocation granularity, respectively. The present embodiment is based on each branch carrier in the LTE system resource allocation granularity, Uniform Resource allocation granularity is determined carrier aggregation in LTE-A system, after the bandwidth. For the first embodiment, since the respective carriers are independent of each branch processing, therefore, the RA type0 way, the prior art may be employed to achieve; however, since the first embodiment, LTE-A system is increased as compared to the LTE system resource allocation granularity, in order to ensure an RBC subset frequency diversity gain, the RA type1 way, the LTE-a system, the number of RBC subset is preferably less than the particle size distribution of resources, and further, can also be combined with a bit indicating a plurality of RB.

This embodiment of the resource allocation granularity LTE system each branch carrier, determine a resource allocation granularity unified carrier aggregation in LTE-A system, after the bandwidth. Guaranteed compatible LTE-A and LTE terminals, saving resources. Border resource conflicts can be avoided by considering the branch carriers. Divided by the resource block group size is smaller than the allocated resource block group subset may

improve the frequency diversity gain. Indicating by a bit more resource blocks can be further improved frequency diversity gain.

Those of ordinary skill will be appreciated: all or part of the above method may be prepared by the procedure of Example program instructing relevant hardware to complete the implementation, the aforementioned program may be stored in a computer readable storage medium, the program is executed, executed the method comprising the steps of the above-described embodiments; and the aforementioned storage medium include: ROM, RAM, disk, or an optical medium can store program codes.

Corresponding to the above-described method, the present embodiment of the invention there is provided a network device, comprising: a resource determining means for allocating to a particle size compatible with the system according to the resource acquired after determining the evolution of the system resource allocation granularity; resource allocation unit, for particle size distribution according to the resource determination unit determines the evolution of resources in the system, indicating the evolution of the system of allocation of resources. In this embodiment, the branch carrier obtained after the evolution of the system in the particle size distribution to the particle size distribution of a compatible system, since the evolution of the system is the particle size distribution of the particle size distribution after consideration of the compatibility of the system, rather than according to the prior art only in accordance with Evolution of the system bandwidth, the prior art can be avoided due to resource issues in post-conflict does not consider to be compatible system allocation granularity caused can ensure LTE-a terminal and LTE compatible terminals. The following detailed description of the apparatus described above, particularly, the aforementioned determining unit comprises resource acquisition module and a determining module, said unit comprising a resource allocation indicating the module:

Figure 10 a schematic view of a tenth embodiment of the present invention, the structure of an example of a network device, comprising an acquisition module 101, a determination module 102 and the indication module 103. 101 acquisition module for acquiring backwards compatible system, each branch carrier bandwidth resource allocation granularity; determining module 102 for post-acquisition module 101 according to the resources available to the bandwidth allocation granularity compatible systems in each branch of the carrier to determine the evolution systems, resource allocation size of each branch carrier bandwidth; module 103 for indicating the resource allocation size determination module 102 to obtain the evolution of the system each branch carrier bandwidth, indicating the evolution of the system, the distribution of resources each branch carrier. Alternatively, the acquisition module 101 for acquiring backwards compatible system, the branch carrier bandwidth resource allocation granularity; module 102 is used to determine the particle size distribution of resources in the branch system compatible carrier bandwidth is determined based on the module 101 to obtain the resulting evolution systems, resource allocation granularity bandwidth branch carrier after polymerization; indication module 103 for resource allocation size determination module 102 to obtain the evolution of the system after the branch carrier aggregation bandwidth, indicating the evolution of the system, according to the

branch after the carrier aggregation assignments.

Specifically, after determining module 102 is specifically configured according to the resource allocation size is compatible with all branches of the system bandwidth carriers, determining the LTE system, resource allocation granularity bandwidth branch carrier after polymerization; or, in all branches to determine the configuration of the carrier to branch carrier terminal, according to the particle size distribution of resources allocated to the terminal branches of the bandwidth of the carrier to determine the evolution of the system, resource allocation granularity bandwidth branch carrier after polymerization. In this case, the specific indication module 103 for the resource allocation granularity bandwidth LTE system carrier aggregation branch after branch resource blocks of bandwidth carriers include one or more resource blocks are divided into groups; each resource block group with a bit instructions; or, the full amount of each resource block groups with a bit indicating the resource block groups in all branches of the carrier is not in full union with a bit indication; or indication module 103 is specifically configured according to the evolution of the system after the branch carrier aggregation resource allocation granularity of bandwidth, the bandwidth of resource blocks included in each branch carrier into one or more resource block groups; the bandwidth of the resource block groups including all branches carriers are divided into N resource block group subset, and  $P = k \times P_1$ , or  $P = 0.5 \times k \times P_1$  Where N is the number of resource blocks subset group, P is the resource allocation granularity bandwidth evolution system branch carrier after polymerization, k is an integer of 0; using a bit map indicating the way each resource block group subsets resources distribution block.

Alternatively, the determination module 102 is used by a specific formula  $P = k \times P_1$ , or  $P = 0.5 \times k \times P_1$ , based on the resource allocation size backward compatible with each branch carrier system bandwidth, determining the evolution of the system, each branch carrier bandwidth resource allocation granularity; after which,  $P_1$  is the compatible system a branch carrier bandwidth resource allocation granularity, P is the bandwidth of the LTE system in the branch carriers resource allocation granularity, k is an integer of 2, for  $P = 0.5 \times k \times P_1$  need to satisfy  $(k \times P_1) \bmod 2 = 0$ . At this time, the module 103 is specifically configured to instruct the resource allocation granularity of a branch carrier in the LTE system bandwidth, the bandwidth of the LTE system resource block of the branch carrier comprises one or more of the resource blocks into groups; the resource block group into N resource block group subsets, and  $P = k \times P_1$ , or  $P = 0.5 \times k \times P_1$  Where N is the number of resource blocks subset group, P is the evolution of the system allocation granularity of the branch carrier bandwidth, k is an integer of 0; using a bit map indicating the way each resource block group subset of resource blocks assignments.

In the present embodiment of the branch system LTE carrier resource allocation granularity obtained independence or unification resource allocation granularity LTE-A system after polymerization, can well be considered a branch of the carrier, the realization of LTE-A terminal and LTE terminal compatible, to avoid waste of resources.

11 eleventh embodiment of the present invention a schematic structural view of a network device, comprising an acquisition module 111, a determination module 112 and the indication module 113, further comprising a notification module 114. 111 acquisition module for acquiring backwards compatible system, each branch carrier bandwidth resource allocation granularity; module 112 is used to determine resource allocation granularity compatible system each branch carrier bandwidth is determined based on the module 111 to obtain the resulting evolution system, each branch carrier bandwidth resource allocation granularity; indication module 113 for particle size distribution determination module 112 obtained according to the evolution of the system each branch carrier bandwidth resources, indicating the evolution of the system, the distribution of resources each branch carrier; notification module 114 is used by way of static configuration, or unicast mode or multicast mode, the module will determine the resulting evolution of the system resource allocation size of each branch carrier bandwidth to the terminal.

Alternatively, the acquiring module 111 for backward compatibility system, each branch carrier bandwidth granularity resource allocation after obtaining; determining module 112 is used to obtain the bandwidth according to each branch system compatible carrier resource allocation module 111 obtained after particle size, determine the evolution of the system, each branch carrier resource allocation granularity aggregated bandwidth; module 113 for indicating the resource allocation size determination module 112 to obtain the evolution of the system after each branch carrier aggregation bandwidth, indicating the evolution of the system, each branch the distribution of resources carrier after polymerization; notification module 114 is used by way of static configuration, or unicast mode or multicast mode, the module size will determine the allocation of resources resulting evolution of the system after each branch carrier aggregation bandwidth sent to the terminal. This embodiment not only can achieve the technical effects of the ninth embodiment, the particle size distribution can also be set up for a static terminal, or by sending unicast particle size distribution for a particular terminal, or sent via multicast for particle size distribution of all terminals.

Further, embodiments of the present invention further provides a radio system comprising a network device, according to the resources after the allocation granularity compatible with the system bandwidth in the branch carriers, determining the LTE system, resource allocation bandwidth branch carrier after polymerization particle size, indicating the LTE system, resource allocation branch carrier after polymerization; or, after the resource allocation according to the size of each branch of the system is compatible with the bandwidth of the carriers, determining the evolution of the system, each branch carrier bandwidth resource allocation granularity indicating that the evolution of the system, the distribution of resources each branch carrier. Specific network devices can be found in FIG. 10, the network device 11 shown in FIG.

In the present embodiment of the branch system LTE carrier resource allocation granularity obtained independence or unification resource allocation granularity LTE-A system after polymerization, can well be considered a branch of the carrier, the realization of LTE-A terminal and LTE terminal compatible, to avoid

waste of resources.

Finally, it should be noted that: The above embodiments are merely provided for describing the technical solutions of the present invention, not to limit it, although with reference to the preferred embodiment of the present invention has been described in detail, those skilled in the art will appreciate: it is still technical solutions of the present invention can be modified or replaced by equivalents, and such modifications or equivalent replacements nor make technical solutions revised departing from the spirit and scope of the present invention, technical solutions.

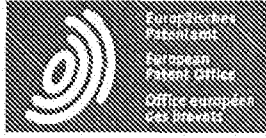

## Notice

This translation is machine-generated. It cannot be guaranteed that it is intelligible, accurate, complete, reliable or fit for specific purposes. Critical decisions, such as commercially relevant or financial decisions, should not be based on machine-translation output.

## CLAIMS CN101765208

[1]

1. A method of resource allocation, characterized in that, comprising: Particle size distribution of resources in the system to be compatible in accordance with acquired after determining the evolution of the system of resource allocation granularity; According to the evolution of the system of resource allocation size, indicating the evolution of the system of allocation of resources.

[2]

2. The method according to claim 1, characterized in that, The particle size distribution of resources in the system to be compatible in accordance with acquired after determining the evolution of the system of resource allocation size, comprising: Backward compatible system, the branch carrier bandwidth granularity resource allocation after obtaining; The particle size distribution compatible carrier system branch according to the bandwidth resources after determining the evolution of the system, bandwidth resources branch carrier particle size distribution after polymerization; According to the evolution of the system resource allocation size, indicating the evolution of the system of allocation of resources, including: the resource allocation size evolution system after the branch carrier aggregation bandwidth, indicating the evolution of the system, the distribution of resources after the branch carrier aggregation .

[3]

3. The method according to claim 2, characterized in that, after the system according to the branch of a compatible carrier bandwidth granularity resource allocation, determining the LTE system, resource allocation granularity bandwidth branch carrier after polymerization include: Distribution system according backwards compatible carriers all branches granularity of bandwidth resources, determining the LTE system, resource allocation granularity bandwidth branch carrier after polymerization; or Determining the carrier allocated to the terminal branches in all branches of carriers, the resource allocation size allocated to the terminal branch of the bandwidth of the carrier to determine the LTE system, resource allocation granularity bandwidth branch carrier after polymerization.

[4]

4. The method according to claim 3, characterized in that, after the system according to the branch of a compatible carrier bandwidth granularity resource allocation, determining the evolution of the system, after the carrier aggregation is calculated branch bandwidth granularity of resource allocation:  $P = \text{LCM}(P_1, \dots, P_n)$ , or  $P = 0.5 \times \text{LCM}(P_1, \dots, P_n)$ ; wherein,  $P_1, \dots, P_n$  are backwards compatible to all branches of the system, or carriers allocated to the terminal a resource allocation bandwidth granularity of the branch carriers,  $P$  is the bandwidth of the LTE system branch carrier after polymerization resource allocation granularity,  $\text{LCM}(P_1, \dots, P_n)$  as  $P_1, \dots, P_n$  is the least common multiple for  $P = 0.5 \times \text{LCM}(P_1, \dots, P_n)$  required to meet  $\text{LCM}(P_1, \dots, P_n) \bmod 2 = 0$ .

[5]

5. The method according to claim 2, characterized in that, according to the granularity of the resource allocation in the LTE system of bandwidth branch carrier after polymerization, indicating the LTE system, resource allocation branch carrier after polymerization include: Based on the resource allocation granularity bandwidth LTE system carrier aggregation branch after branch resource blocks of bandwidth carriers include one or more resource blocks are divided into groups; Each resource block group with a bit indication; or each resource block group with the full bit indicating a resource block group in all the branches of the carrier is not combined with a bit full instructions.

[6]

6. The method according to claim 2, characterized in that, according to the granularity of the resource allocation