

A yellow circuit diagram border frames the text. It consists of a top horizontal line with a transformer symbol (two overlapping arches) in the center, connected to two yellow circles. Two vertical lines connect these circles to a bottom horizontal line, which also connects to two yellow circles. A switch symbol is located on the bottom horizontal line between the two right-side circles.

MODERN DC-TO-DC SWITCH MODE POWER CONVERTER CIRCUITS

Rudolf P. Severns
Gordon E. Bloom

Van Nostrand Reinhold Electrical/Computer Science and Engineering Series

**MODERN
DC-TO-DC
SWITCHMODE
POWER
CONVERTER
CIRCUITS**

Rudolf P. Severns

Senior Staff Engineer
Applications Engineering
SILICONIX, INC.

Gordon (Ed) Bloom

Senior Partner and Engineering Specialist
e/j BLOOM Associates

Van Nostrand Reinhold Electrical/Computer Science and Engineering Series



VAN NOSTRAND REINHOLD COMPANY

New York

Copyright © 1985 by Rudolf P. Severns and Gordon Bloom

Library of Congress Catalog Card Number: 84-12026
ISBN: 0-442-21396-4

All rights reserved. No part of this work covered by the copyright hereon may be reproduced in any form or by any means—graphic, electronic, or mechanical, including photocopying, recording, taping, or information storage and retrieval systems—without permission of the publisher.

Manufactured in the United States of America

Published by Van Nostrand Reinhold Company Inc.
135 West 50th Street
New York, New York 10020

Van Nostrand Reinhold Company Limited
Molly Millars Lane
Wokingham, Berkshire RG11 2PY, England

Van Nostrand Reinhold
480 Latrobe Street
Melbourne, Victoria 3000, Australia

Macmillan of Canada
Division of Gage Publishing Limited
164 Commander Boulevard
Agincoet, Ontario M1S 3C7, Canada

15 14 13 12 11 10 9 8 7 6 5 4 3 2 1

Library of Congress Cataloging in Publication Data

Severns, Rudolf P.
Modern DC-to-DC switchmode power converter circuits.

(Van Nostrand Reinhold electrical/computer science and engineering series)

Bibliography: p.

Includes index.

1. Electronic apparatus and appliances—Power supply.
 2. Microelectronics—Power supply. I. Bloom, Gordon.
- II. Title. III. Title: Modern DC-to-DC switchmode power converter circuits. IV. Series.

TK7868.P6547 1984 621.3815'32 84-12026
ISBN 0-442-21396-4

and L in Fig. 7.4A as an essential SPC feature and, by processes of rotation and mirror-imaging, used to logically evolve buck or boost SPC topologies.

As we have seen, it is possible by a simple manipulation to derive the buck-boost converter topology from the cascade connection of the two elementary converters. The derivation of the buck-boost SPC small-signal model given in Chapter 10 also supports this view. For these reasons, we have chosen here to classify the buck-boost converter as a special combination of buck and boost SPCs, rather than an elementary converter unto itself. Since this assumption has proven to be self-consistent, we have retained it throughout the discussions of this text, but certainly the point of origin of this converter topology is an arguable one.

When multiple outputs and/or DC isolation from input to output are desired in a buck-boost converter, it is not necessary to incorporate a DC transformer, as we will see. Consider the buck-boost circuit of Fig. 7.5A, where the inductor L now has two identical windings in parallel. This winding addition does not alter the basic converter operation. Next, the links connecting the two inductor windings are removed, as shown in Fig. 7.5A. Again, circuit operation remains the same except that DC isolation between the input and the output has been achieved. The final step in this process is shown in Fig. 7.5C, where additional secondary windings have been introduced in the inductor assembly with arbitrary turns ratios relative to the inductor "primary." This transformer-isolated multiple-output form of the buck-boost SPC is called the *flyback converter* and is probably the most popular circuit in use today for output power levels below 50 W. Its primary advantage is simplicity, particularly in that only one magnetic component is needed, even when input-to-output DC isolation and/or multiple outputs are required from the converter. The primary difficulty associated with this SPC is the design of inductor L , which now assumes the roles of both an energy-storage device and a transformer element. Its design becomes even more difficult when multiple outputs with good cross regulation are required. Successful flyback SPC design examples with as many as 25 isolated outputs do exist, but their magnetics designs were very complicated.

Besides the pulsating input and output current characteristic and the high switch currents mentioned earlier, the control-to-output small-signal transfer function of the buck-boost has a *right half-plane zero*, as we will see in Chapter 10. The presence of this troublesome zero should come as no surprise since one of the elementary constituents of the buck-boost converter has a similar control-to-output transfer function.

When a buck SPC is preceded by a boost SPC, as shown in Fig. 7.6A, quite a different, and in many ways a more useful converter can be derived in much the same manner as was followed to evolve the buck-boost and flyback SPCs. In Fig. 7.6B, the two switch-and-diode sets are replaced by a single DPDT switch. In this case, $C1$ cannot be omitted since it is required for energy storage. As was

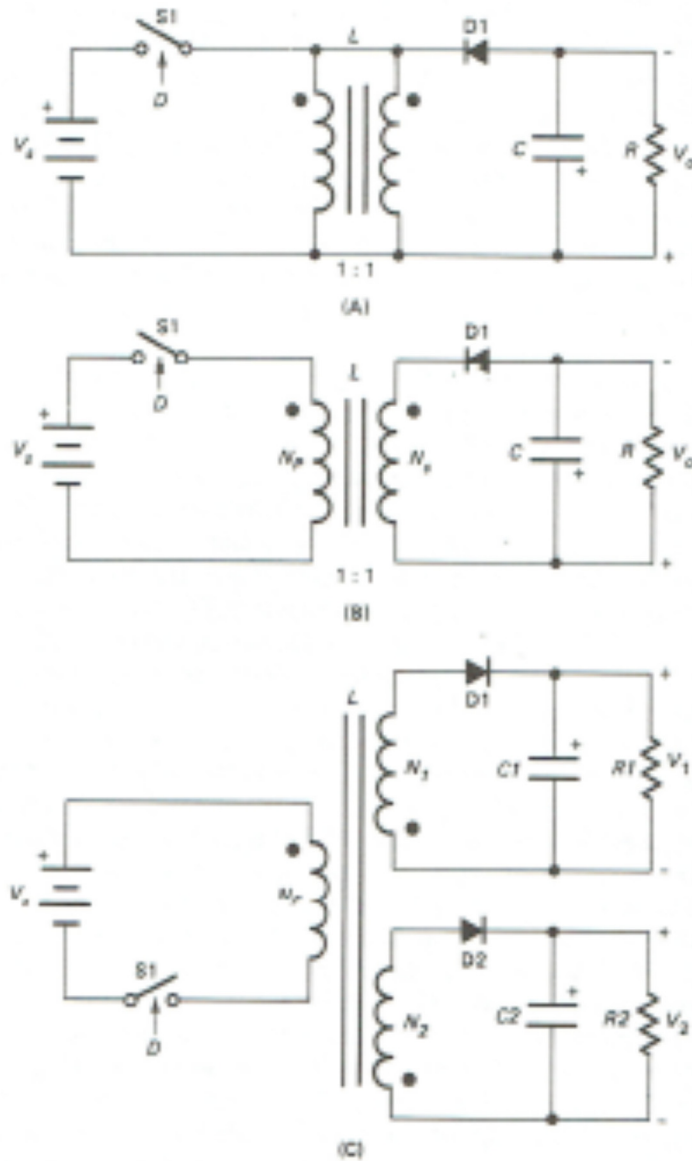

Fig. 7.5. Derivation of the flyback converter from the buck-boost converter.

the case for the buck-boost, if a polarity inversion of output voltage is permitted, the circuit can be further simplified. As indicated in Fig. 7.6C, the DPDT switch and shunt capacitor network can be replaced by a SPDT switch and a series capacitor. A practical realization of this new circuit is shown in Fig. 7.6D. This