

CMOS

CIRCUIT DESIGN, LAYOUT, AND SIMULATION

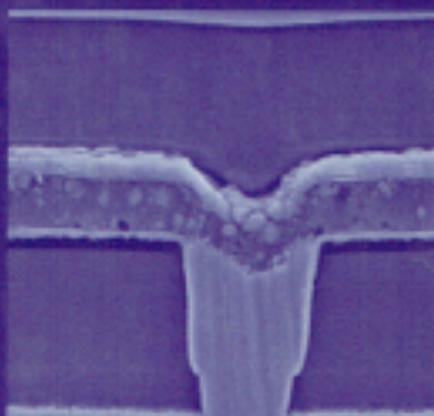
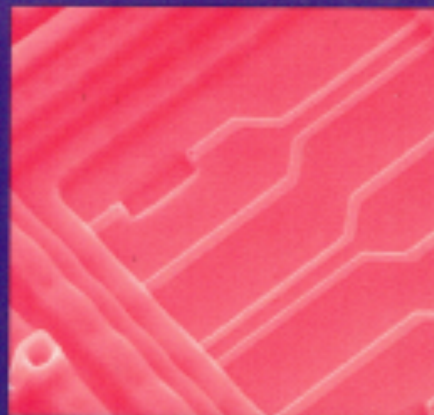
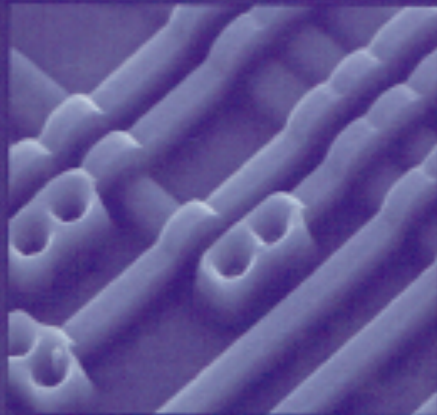

R. Jacob Baker ■ Harry W. Li ■ David E. Boyce

IEEE Press Series on Microelectronic Systems
Stuart K. Tewksbury, *Series Editor*

The LASI Layout Software, as well as other
layout software, can be downloaded at
http://www.mrc.uidaho.edu/vlsi/cad_free.html

CMOS

Circuit Design, Layout, and Simulation

R. Jacob Baker, Harry W. Li and David E. Boyce
Department of Electrical Engineering
Microelectronics Research Center
The University of Idaho

IEEE Press Series on Microelectronic Systems
Stuart K. Tewksbury, *Series Editor*

IEEE Circuits & Systems Society, *Sponsor*
IEEE Solid-State Circuits Society, *Sponsor*



The Institute of Electrical and Electronics Engineers, Inc., New York

This book and other books may be purchased at a discount from the publisher when ordered in bulk quantities. Contact:

IEEE Press Marketing
Attn: Special Sales
Piscataway, NJ 08855-1331
Fax: (732) 981-9334

For more information about IEEE PRESS products,
visit the IEEE Home Page: <http://www.ieee.org/>

© 1998 by the Institute of Electrical and Electronics Engineers, Inc.
345 East 47th Street, New York, NY 10017-2394

All rights reserved. No part of this book may be reproduced in any form, nor may it be stored in a retrieval system or transmitted in any form, without written permission from the publisher.

Printed in the United States of America

10 9 8 7 6 5 4

ISBN 0-7803-3416-7
IEEE Order Number: PC5689

Library of Congress Cataloging-in-Publication Data

Baker, R. Jacob (date)

CMOS circuit design, layout, and simulation / R. Jacob Baker,
Harry W. Li, and David E. Boyce.

p. cm. -- (IEEE Press series on microelectronic systems)

Includes bibliographical references and index.

ISBN 0-7803-3416-7

1. Metal oxide semiconductors, Complementary--Design and construction. 2. Integrated circuits--Design and construction.

3. Metal oxide semiconductor field-effect transistors. I. Li, Harry W. II. Boyce, David E. III. Title. IV. Series

TK7871.99.M44B35 1997

621.3815--DC21

97-21906

CIP

current in M5 and M6. When the output of the oscillator is low, M3 is on and M2 is off. This allows the constant current from M4 to charge C . When the voltage across C reaches V_{TH} , the output of the Schmitt trigger swings low. This causes the output of the oscillator to go high and allows the constant current from M1 to discharge C . When C is discharged down to V_{TL} , the Schmitt trigger changes states. This series of events continues, generating the square wave output.

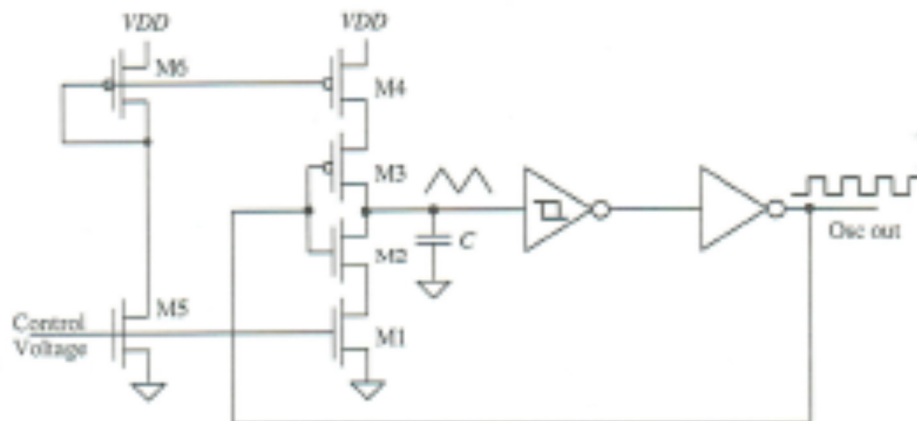

Figure 18.8 Voltage-controlled-oscillator using Schmitt trigger and current sources. MOSFETs M2 and M3 are used as switches.

If we label the drain currents of M1 and M4 as I_{D1} and I_{D4} , we can estimate the time it takes the capacitor to charge from V_{TL} to V_{TH} as

$$t_1 = C \cdot \frac{V_{TH} - V_{TL}}{I_{D4}} \quad (18.14)$$

and the time it takes to charge from V_{TH} to V_{TL} is

$$t_2 = C \cdot \frac{V_{TH} - V_{TL}}{I_{D1}} \quad (18.15)$$

The period of the oscillation frequency is, as before, the sum of t_1 and t_2 .

This type of oscillator is termed a voltage-controlled oscillator (VCO) since the output frequency can be controlled by an external voltage. The currents I_{D1} and I_{D4} (Fig. 18.8) are directly controlled by the control voltage. As we will see in Ch. 20, the current in M5 is mirrored in M1, M4, and M6, with an appropriate scaling factor dependent on the size of the transistors.

18.1.4 High-Speed Schmitt Trigger

It turns out in practice that the Schmitt trigger of Fig. 18.3 is not easily optimized for high speed. The effective switching resistances of the MOSFETs are difficult to reduce