



US006825620B2

(12) **United States Patent**
Kuennen et al.

(10) **Patent No.:** **US 6,825,620 B2**
(45) **Date of Patent:** **Nov. 30, 2004**

(54) **INDUCTIVELY COUPLED BALLAST CIRCUIT**

843,534 A	2/1907	Hewitt	315/248
1,137,333 A	4/1915	Klorer	403/57
1,604,870 A	10/1926	Asman	403/396
1,803,571 A	5/1931	Ulman	362/92

(75) Inventors: **Roy W. Kuennen**, Caledonia, MI (US); **Scott A. Mollema**, Grand Rapids, MI (US); **David W. Baarman**, Fennville, MI (US); **Ronald C. Markham**, Grand Rapids, MI (US); **Dennis J. Denen**, Westerville, OH (US)

(List continued on next page.)

FOREIGN PATENT DOCUMENTS

(73) Assignee: **Access Business Group International LLC**, Ada, MI (US)

AT	370929	5/1983
AU	A-61741/86	2/1988
DE	2029468	12/1971
DE	4100272	7/1991
DE	9012505	8/1991

(List continued on next page.)

(*) Notice: Subject to any disclaimer, the term of this patent is extended or adjusted under 35 U.S.C. 154(b) by 156 days.

OTHER PUBLICATIONS

(21) Appl. No.: **10/246,155**

"Best of Show", Fortune, Feb. 17, 2003.

(22) Filed: **Sep. 18, 2002**

(65) **Prior Publication Data**

(List continued on next page.)

US 2003/0015479 A1 Jan. 23, 2003

Related U.S. Application Data

Primary Examiner—Thuy Vinh Tran

(63) Continuation-in-part of application No. 10/175,095, filed on Jun. 18, 2002, now Pat. No. 6,673,250, which is a continuation-in-part of application No. 09/592,194, filed on Jun. 12, 2000, now Pat. No. 6,436,299.

(74) *Attorney, Agent, or Firm*—Warner Norcross & Judd LLP

(60) Provisional application No. 60/140,159, filed on Jun. 21, 1999, and provisional application No. 60/140,090, filed on Jun. 21, 1999.

(57) **ABSTRACT**

(51) **Int. Cl.**⁷ **H05B 37/02**

A ballast circuit is disclosed for inductively providing power to a load. The ballast circuit includes an oscillator, a driver, a switching circuit, a resonant tank circuit and a current sensing circuit. The current sensing circuit provides a current feedback signal to the oscillator that is representative of the current in the resonant tank circuit. The current feedback signal drives the frequency of the ballast circuit causing the ballast circuit to seek resonance. The ballast circuit preferably includes a current limit circuit that is inductively coupled to the resonant tank circuit. The current limit circuit disables the ballast circuit when the current in the ballast circuit exceeds a predetermined threshold or falls outside a predetermined range.

(52) **U.S. Cl.** **315/224; 315/276; 315/283; 315/291**

(58) **Field of Search** 315/209 R, 219–220, 315/224–225, 244, 291, 302, 307, DIG. 7, 57, 62, 248, 276, 283

(56) **References Cited**

U.S. PATENT DOCUMENTS

602,966 A 4/1898 Wallach 362/219

59 Claims, 15 Drawing Sheets

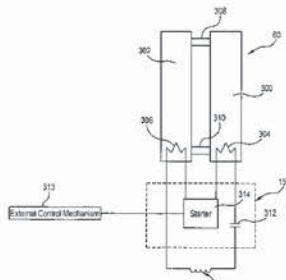
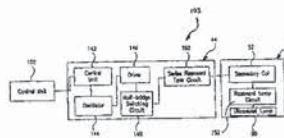

U.S. PATENT DOCUMENTS

1,852,740	A	4/1932	Doane	362/304
2,199,107	A	4/1940	Kibbe	359/801
2,265,475	A	12/1941	Fodor	315/76
2,353,063	A	7/1944	Otis	40/406
2,686,866	A	8/1954	Williams	362/231
2,726,116	A	12/1955	Barner	239/18
2,731,547	A	1/1956	Callard	362/257
3,047,765	A	7/1962	Vichill	313/318.08
3,292,579	A	12/1966	Buchanan	119/245
3,550,682	A	12/1970	Fowler	166/338
3,551,091	A	12/1970	Veloz	210/251
3,628,086	A	12/1971	Nuckolls	315/80
3,641,336	A	2/1972	Boin	362/183
3,743,989	A	7/1973	Nicolas et al.	336/5
3,746,906	A	7/1973	Cardwell, Jr.	313/318.04
3,867,661	A	2/1975	Waltz et al.	313/26
3,885,185	A	5/1975	Tilley	313/318.03
3,885,211	A	5/1975	Gutai	320/108
3,923,663	A	12/1975	Reid	210/151
3,938,018	A	2/1976	Dahl	320/140
4,005,330	A	1/1977	Glascocok, Jr. et al.	315/248
4,010,400	A	3/1977	Hollister	315/57
4,017,764	A	4/1977	Anderson	315/248
4,038,625	A	7/1977	Tompkins et al.	336/83
4,093,893	A	6/1978	Anderson	315/48
4,101,777	A	7/1978	Reid	250/436
4,117,378	A	9/1978	Glascocok, Jr.	315/248
4,282,563	A	8/1981	Ohta et al.	362/216
4,300,073	A	11/1981	Skwirut et al.	315/53
4,389,595	A	6/1983	Kamei et al.	315/57
4,414,489	A	11/1983	Young	315/51
4,615,799	A	10/1986	Mortensen	210/177
4,637,434	A	1/1987	Moen	137/625.66
4,675,573	A	6/1987	Miram et al.	315/94
4,675,638	A	6/1987	Szabo	336/83
4,752,401	A	6/1988	Bodenstein	210/476
4,762,613	A	8/1988	Snowball	210/192
4,772,991	A	9/1988	Wood	362/287
4,800,328	A	1/1989	Bolger et al.	320/106
4,812,702	A	3/1989	Anderson	313/153
4,816,977	A	3/1989	Sorensen	362/448
4,818,855	A	4/1989	Mongeon et al.	235/440
4,838,797	A	6/1989	Dodier	439/138
4,854,214	A	8/1989	Lowe	84/404
4,857,204	A	8/1989	Joklik	210/695
4,894,591	A	1/1990	Witting	315/248
4,954,756	A	9/1990	Wood et al.	315/39
4,958,266	A	9/1990	Sorensen et al.	362/360
4,968,437	A	11/1990	Noll et al.	210/748
4,971,687	A	11/1990	Anderson	604/248
4,972,120	A	11/1990	Witting	313/638
4,977,354	A	12/1990	Bergervoet et al.	315/248
5,030,889	A	7/1991	El-Hamamsy et al.	315/200 R
5,039,903	A	8/1991	Farrall	313/160
5,041,763	A	8/1991	Sullivan et al.	315/176
5,070,293	A	12/1991	Ishii et al.	320/2
5,101,332	A	3/1992	Hsia	362/401
5,122,729	A	6/1992	Itoga et al.	323/347
5,141,325	A	8/1992	Huang	362/413
5,146,140	A	9/1992	Piejak et al.	315/248
5,158,361	A	10/1992	Huang	362/414
5,173,643	A	* 12/1992	Sullivan et al.	315/276
5,184,891	A	2/1993	Shpigel	362/419
5,216,402	A	6/1993	Carosa	336/66
5,229,652	A	7/1993	Hough	307/104
5,267,997	A	12/1993	Farin et al.	606/38
5,280,416	A	1/1994	Hartley et al.	362/98
5,289,085	A	2/1994	Godyak et al.	136/244

5,311,028	A	5/1994	Glavish	250/497.1
5,339,233	A	8/1994	Yang	362/402
5,416,388	A	5/1995	Shackle	315/219
5,422,519	A	6/1995	Russell	307/104
5,450,305	A	9/1995	Boys et al.	363/24
5,455,466	A	10/1995	Parks et al.	307/104
5,455,467	A	10/1995	Young et al.	307/104
5,465,025	A	11/1995	Hendrickson	313/318.09
5,506,560	A	4/1996	Takeuchi et al.	336/83
5,536,979	A	7/1996	McEachern et al.	307/104
5,550,452	A	8/1996	Shirai et al.	320/2
5,594,304	A	1/1997	Graber	315/85
5,611,918	A	3/1997	Markham	210/87
5,619,182	A	4/1997	Robb	340/479
5,653,531	A	8/1997	Yang	362/352
5,675,677	A	10/1997	Davenport et al.	385/31
5,680,028	A	10/1997	McEachern	320/2
5,716,126	A	2/1998	Meyer	362/287
5,747,894	A	5/1998	Hirai et al.	307/104
5,747,942	A	* 5/1998	Ranganath	315/224
5,796,216	A	* 8/1998	Beasley	315/307
5,814,900	A	9/1998	Esser et al.	307/104
5,831,348	A	11/1998	Nishizawa	307/104
5,831,516	A	11/1998	Jennings	340/392.4
5,834,905	A	11/1998	Godyak et al.	315/248
5,905,343	A	5/1999	McCamant	315/57
5,914,572	A	* 6/1999	Qian et al.	315/307
5,923,544	A	7/1999	Urano	363/22
5,925,985	A	* 7/1999	Zeng et al.	315/224
5,928,505	A	7/1999	Inakagata et al.	210/91
5,929,598	A	7/1999	Nakama et al.	320/107
5,949,155	A	9/1999	Tamura et al.	307/107
5,951,155	A	9/1999	Lanser	362/490
5,952,814	A	9/1999	VanLersergh	320/108
5,980,056	A	11/1999	West	362/86
5,990,611	A	11/1999	Lee	313/493
6,005,304	A	12/1999	Seelig	307/104
6,020,682	A	2/2000	Holzer	313/493
6,027,225	A	2/2000	Martin et al.	362/183
6,028,413	A	2/2000	Brockmann	320/108
6,075,433	A	6/2000	Ono et al.	336/212
6,118,249	A	9/2000	Brockmann et al.	320/108
6,160,371	A	12/2000	Tachikawa	318/568.11
6,161,032	A	12/2000	Acker	600/424
6,166,494	A	12/2000	Green	315/209 R
6,188,179	B1	2/2001	Boys et al.	315/244
6,194,828	B1	2/2001	Kohne et al.	313/493
6,218,785	B1	4/2001	Incerti	315/185 S
6,241,359	B1	6/2001	Lin	362/96
6,263,247	B1	7/2001	Mueller et al.	607/60
6,275,143	B1	8/2001	Stobbe	340/10.34
6,280,066	B1	8/2001	Dolan	362/414
6,291,936	B1	9/2001	MacLennan et al.	315/39
6,301,128	B1	10/2001	Jang et al.	363/17
6,307,316	B1	10/2001	Holzer	313/493
6,322,226	B1	11/2001	Dickson	362/33
6,326,739	B1	12/2001	MacLennan et al.	315/248
6,339,296	B1	1/2002	Goral	315/86
6,345,203	B1	2/2002	Mueller et al.	607/60
6,436,299	B1	8/2002	Baarman et al.	210/748
6,462,432	B1	10/2002	Seelig et al.	307/133
6,597,076	B2	7/2003	Scheible et al.	307/104

FOREIGN PATENT DOCUMENTS

DE	4238388	5/1994
DE	4421253	3/1995
DE	4412957	10/1995
DE	19540854	5/1997
EP	0 433 752 A1	* 6/1991

GB	2388715 A	11/2003
GB	2388716 A	11/2003
JP	8-31585	2/1996
WO	WO 97/17761	5/1997
WO	WO 97/26705	7/1997
WO	WO 00/22892	4/2000
WO	WO 00/32298	6/2000
WO	WO 01/26427	4/2001
WO	WO 01/26431	4/2001

WO	WO 03/096361	11/2003
WO	WO 03/105311	12/2003

OTHER PUBLICATIONS

“Splashpower”, www.splashpower.com, Feb. 11, 2003.

“Mobilewise”, www.mobilewise.com, Feb. 11, 2003.

* cited by examiner

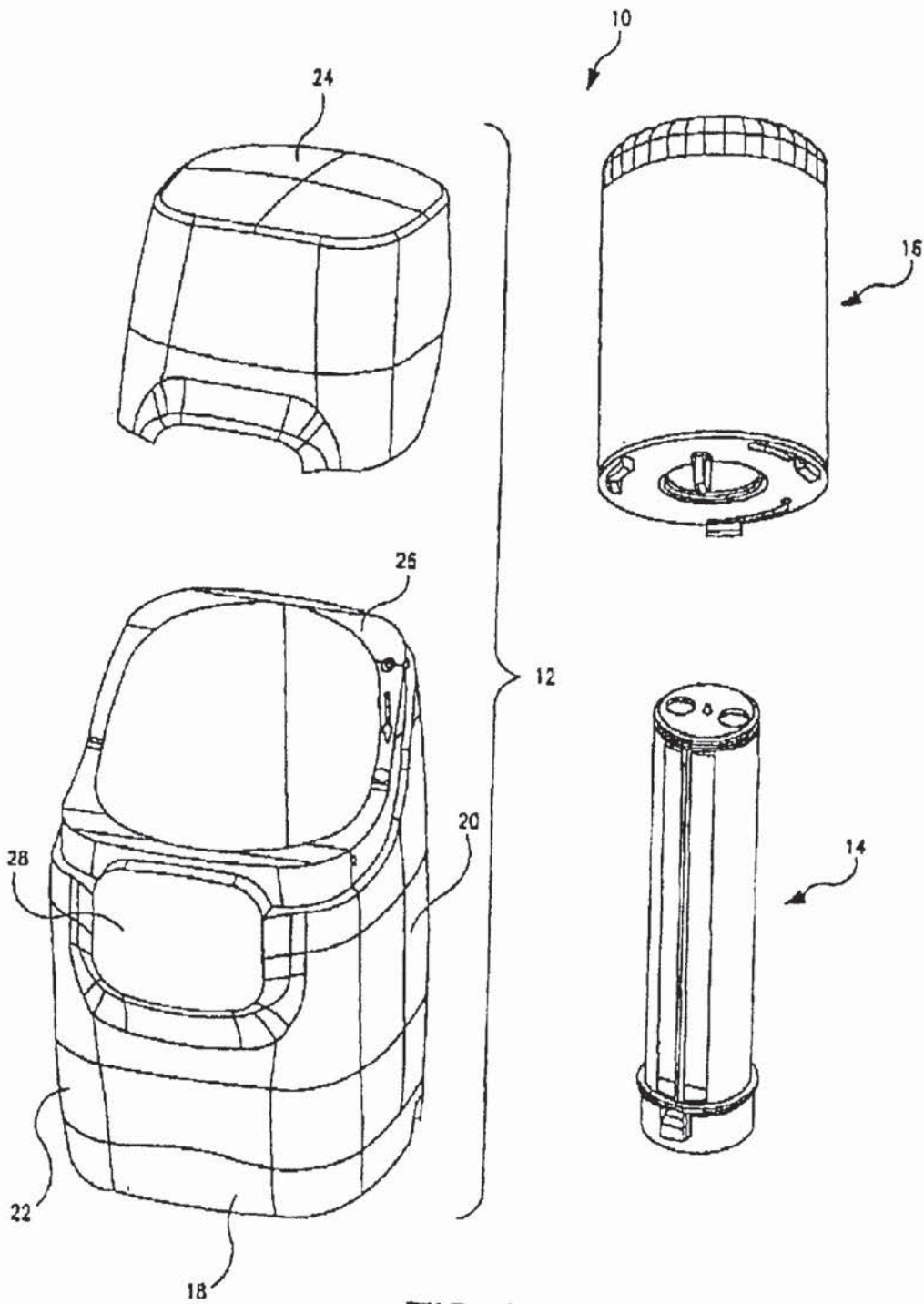

FIG. 1

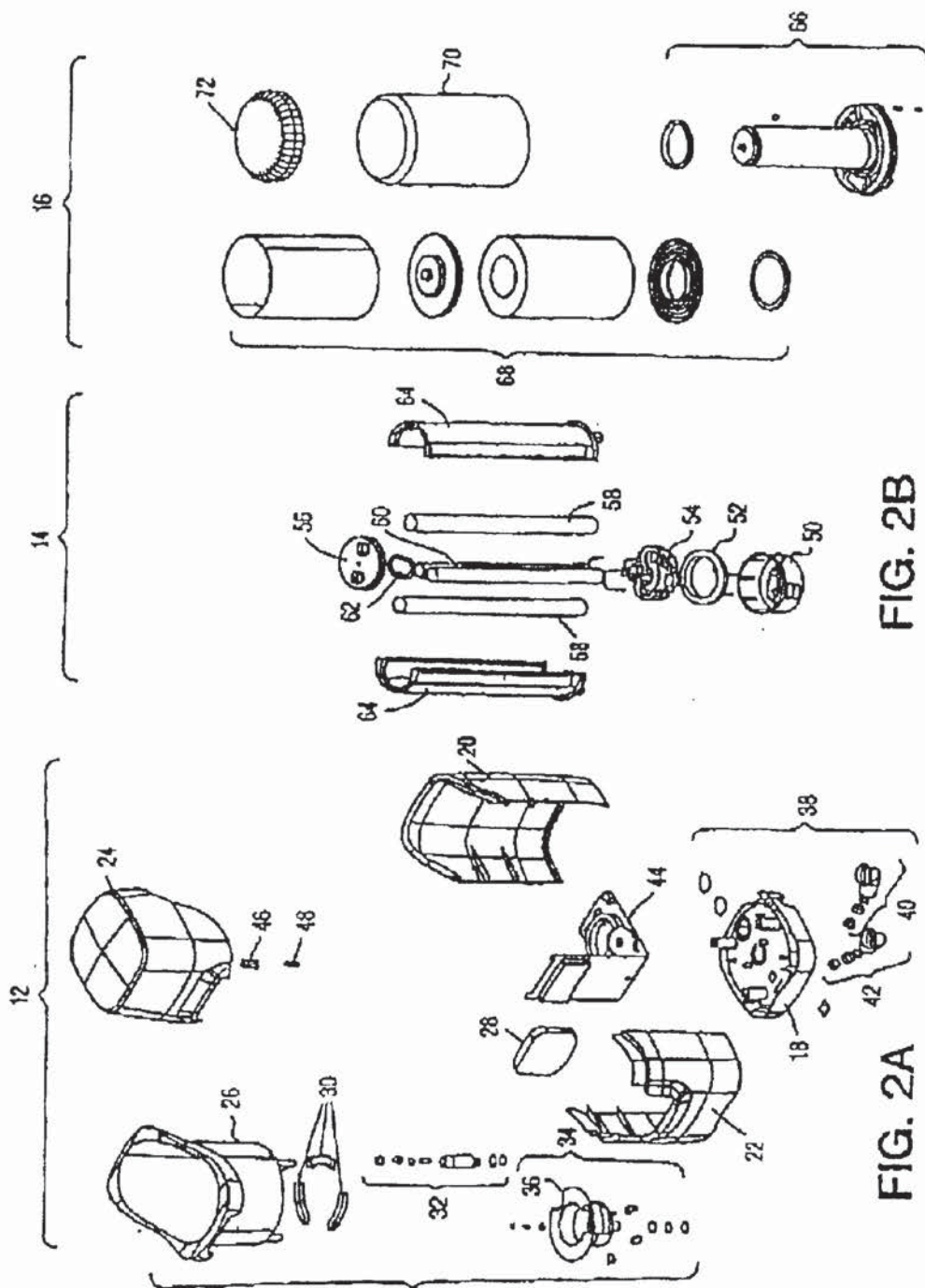

FIG. 2C

FIG. 2B

FIG. 2A

Explore Litigation Insights

Docket Alarm provides insights to develop a more informed litigation strategy and the peace of mind of knowing you're on top of things.

Real-Time Litigation Alerts



Keep your litigation team up-to-date with **real-time alerts** and advanced team management tools built for the enterprise, all while greatly reducing PACER spend.

Our comprehensive service means we can handle Federal, State, and Administrative courts across the country.

Advanced Docket Research



With over 230 million records, Docket Alarm's cloud-native docket research platform finds what other services can't. Coverage includes Federal, State, plus PTAB, TTAB, ITC and NLRB decisions, all in one place.

Identify arguments that have been successful in the past with full text, pinpoint searching. Link to case law cited within any court document via Fastcase.

Analytics At Your Fingertips



Learn what happened the last time a particular judge, opposing counsel or company faced cases similar to yours.

Advanced out-of-the-box PTAB and TTAB analytics are always at your fingertips.

API

Docket Alarm offers a powerful API (application programming interface) to developers that want to integrate case filings into their apps.

LAW FIRMS

Build custom dashboards for your attorneys and clients with live data direct from the court.

Automate many repetitive legal tasks like conflict checks, document management, and marketing.

FINANCIAL INSTITUTIONS

Litigation and bankruptcy checks for companies and debtors.

E-DISCOVERY AND LEGAL VENDORS

Sync your system to PACER to automate legal marketing.