



US009509440B2

(12) **United States Patent**
Hammarwall et al.

(10) **Patent No.:** **US 9,509,440 B2**
(45) **Date of Patent:** **Nov. 29, 2016**

(54) **METHOD AND RADIO NODE FOR ENABLING USE OF HIGH ORDER MODULATION IN A RADIO COMMUNICATION WITH A USER EQUIPMENT**

(56) **References Cited**

U.S. PATENT DOCUMENTS

2015/0358111 A1* 12/2015 Mariner H04L 1/0003 370/329

(71) Applicant: **Telefonaktiebolaget L M Ericsson (publ)**, Stockholm (SE)

FOREIGN PATENT DOCUMENTS

(72) Inventors: **David Hammarwall**, Vallentuna (SE); **Meng Wang**, Solna (SE)

CN 102624481 A 8/2012
W● 2013123961 A1 8/2013
W● 2014109915 A1 7/2014

(73) Assignee: **Telefonaktiebolaget LM Ericsson (publ)**, Stockholm (SE)

OTHER PUBLICATIONS

(*) Notice: Subject to any disclaimer, the term of this patent is extended or adjusted under 35 U.S.C. 154(b) by 56 days.

Panasonic, "Discussion on 256QAM for Downlink in Small Cell Deployments", 3GPP TSG-RAN WG1 Meeting 72bis, Apr. 15, 2013, pp. 1-6, R1-131328, Chicago, US.

(Continued)

(21) Appl. No.: **14/390,904**

Primary Examiner — Diane Lo

(22) PCT Filed: **Jun. 26, 2014**

(74) Attorney, Agent, or Firm — Coats & Bennett, P.L.L.C.

(86) PCT No.: **PCT/SE2014/050803**

§ 371 (c)(1),
(2) Date: **Oct. 6, 2014**

(57) **ABSTRACT**

(87) PCT Pub. No.: **WO2015/020587**

PCT Pub. Date: **Feb. 12, 2015**

A method and radio node (500) for enabling higher-order modulation in a radio communication with a first UE (502). A first table configuration comprises at least one of a first Modulation and Coding Scheme, MCS, table and a first Channel Quality Indicator, CQI, table which tables support a certain maximum modulation order. When the radio node (500) detects that a modulation order higher than the maximum modulation order of the first table configuration is potentially possible to use in the radio communication, the radio node (500) instructs the first UE (502) to apply a second table configuration which comprises at least one of a second MCS table and a second CQI table which second tables support the higher modulation order. At least one entry for at least one modulation order in the tables of the first table configuration is maintained in the tables of the second table configuration as a fall-back in case it is desirable to use the at least one modulation order of the first table configuration when the second table configuration is applied. Thereby, a higher data rate can be achieved in the radio communication.

(65) **Prior Publication Data**

US 2015/0381310 A1 Dec. 31, 2015

Related U.S. Application Data

(60) Provisional application No. 61/863,935, filed on Aug. 9, 2013.

(51) **Int. Cl.**
H04L 1/00 (2006.01)
H04W 72/08 (2009.01)

(52) **U.S. Cl.**
CPC **H04L 1/0005** (2013.01); **H04L 1/0003** (2013.01); **H04L 1/0009** (2013.01);

(Continued)

(58) **Field of Classification Search**

None
See application file for complete search history.

28 Claims, 7 Drawing Sheets

Modulation	Q _m	Bits
0	2	0
1	2	1
2	2	2
3	2	3
4	2	4
5	2	5
6	2	6
7	2	7
8	2	8
9	2	9
10	4	10
11	4	11
12	4	12
13	4	13
14	4	14
15	4	15
16	4	16
17	4	17
18	4	18
19	4	19
20	4	20
21	4	21
22	4	22
23	4	23
24	4	24
25	4	25
26	4	26
27	4	27
28	4	28
29	4	29
30	4	reserved

- (52) **U.S. Cl.**
CPC *H04L1/0011* (2013.01); *H04L 1/0016*
(2013.01); *H04L 1/0025* (2013.01); *H04L*
1/0026 (2013.01); *H04W 72/082* (2013.01)

(56) **References Cited**

OTHER PUBLICATIONS

Huawei, et al., "Standard Impacts to Support Higher Order Modulation", 3GPP TSG-RAN WG1 Meeting 73, May 20, 2013, pp. 1-2, R1-131853, Fukuoka, JP.

HTC, "On Small Cell Enhancement for improved Spectral Efficiency", 3GPP TSG RAN WG1 Meeting #72, Jan. 28, 2013, pp. 1-4, R1-130311, St. Julian's, Malta.

Intel Corporation, "CQI/MCS/TBS Tables for 256QAM and Relevant Signaling", 3GPP TSG RAN WG1 Meeting #76, Feb. 10, 2014, pp. 1-8, R1-140118, Prague, Czech Republic.

3rd Generation Partnership Project, "LTE; Evolved Universal Terrestrial Radio Access (E-UTRA); Physical layer procedures (3GPP TS 36.213 version 11.2.0 Release 11)", Technical Specification, ETSI TS 136 213 V11.2.0, Apr. 1, 2013, pp. 1-175, ETSI, France.

* cited by examiner

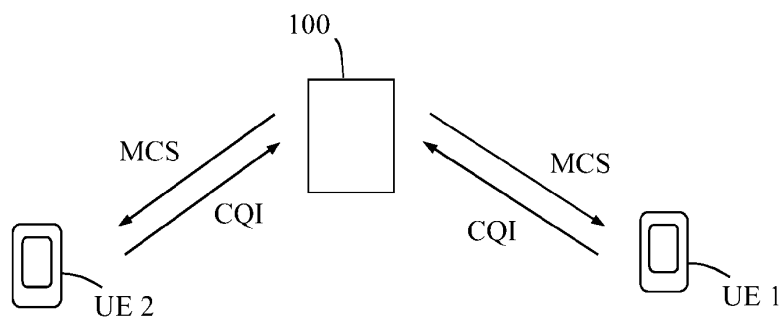

Fig. 1 (Prior art)

MCS Index	Modulation Order	TBS Index
I_{MCS}	Q_m	I_{TBS}
0	2	0
1	2	1
2	2	2
3	2	3
4	2	4
5	2	5
6	2	6
7	2	7
8	2	8
9	2	9
10	4	9
11	4	10
12	4	11
13	4	12
14	4	13
15	4	14
16	4	15
17	6	15
18	6	16
19	6	17
20	6	18
21	6	19
22	6	20
23	6	21
24	6	22
25	6	23
26	6	24
27	6	25
28	6	26
29	2	reserved
30	4	
31	6	

Fig. 2

CQI index	modulation	code rate x 1024	efficiency
0	out of range		
1	QPSK	78	0.1523
2	QPSK	120	0.2344
3	QPSK	193	0.3770
4	QPSK	308	0.6016
5	QPSK	449	0.8770
6	QPSK	602	1.1758
7	16QAM	378	1.4766
8	16QAM	490	1.9141
9	16QAM	616	2.4063
10	64QAM	466	2.7305
11	64QAM	567	3.3223
12	64QAM	666	3.9023
13	64QAM	772	4.5234
14	64QAM	873	5.1152
15	64QAM	948	5.5547

Fig. 3

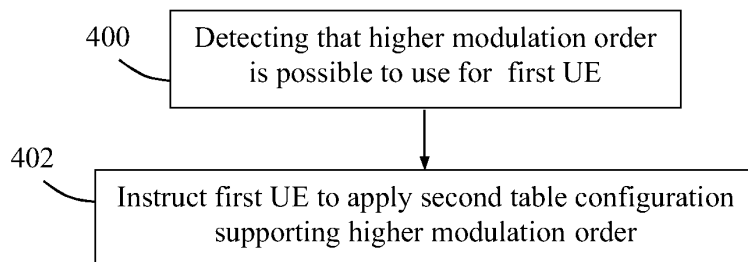

Fig. 4

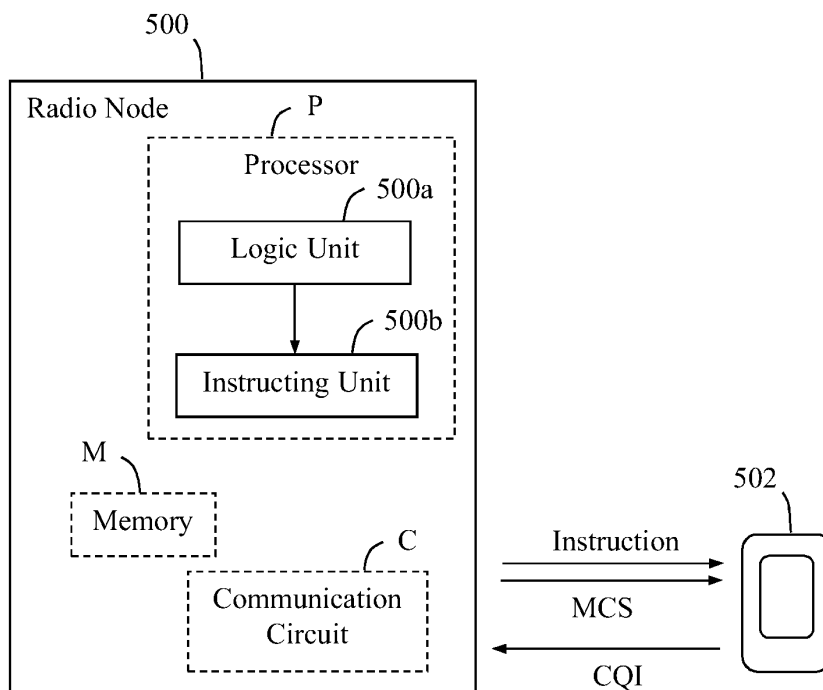

Fig. 5

Explore Litigation Insights

Docket Alarm provides insights to develop a more informed litigation strategy and the peace of mind of knowing you're on top of things.

Real-Time Litigation Alerts



Keep your litigation team up-to-date with **real-time alerts** and advanced team management tools built for the enterprise, all while greatly reducing PACER spend.

Our comprehensive service means we can handle Federal, State, and Administrative courts across the country.

Advanced Docket Research



With over 230 million records, Docket Alarm's cloud-native docket research platform finds what other services can't. Coverage includes Federal, State, plus PTAB, TTAB, ITC and NLRB decisions, all in one place.

Identify arguments that have been successful in the past with full text, pinpoint searching. Link to case law cited within any court document via Fastcase.

Analytics At Your Fingertips



Learn what happened the last time a particular judge, opposing counsel or company faced cases similar to yours.

Advanced out-of-the-box PTAB and TTAB analytics are always at your fingertips.

API

Docket Alarm offers a powerful API (application programming interface) to developers that want to integrate case filings into their apps.

LAW FIRMS

Build custom dashboards for your attorneys and clients with live data direct from the court.

Automate many repetitive legal tasks like conflict checks, document management, and marketing.

FINANCIAL INSTITUTIONS

Litigation and bankruptcy checks for companies and debtors.

E-DISCOVERY AND LEGAL VENDORS

Sync your system to PACER to automate legal marketing.