

UNITED STATES PATENT AND TRADEMARK OFFICE

BEFORE THE PATENT TRIAL AND APPEAL BOARD

APPLE INC.,

Petitioner

v.

TELEFONAKTIEBOLAGET LM ERICSSON,

Patent Owner

Inter Partes Review Case No. IPR2022-00457

U.S. Patent No. 9,509,440

**DECLARATION OF JAMES L. MULLINS, PhD
IN SUPPORT OF PETITION FOR *INTER PARTES* REVIEW OF
U.S. PATENT NO. 9,509,440**

TABLE OF CONTENTS

I. INTRODUCTION1

II. BACKGROUND AND QUALIFICATIONS2

III. BACKGROUND ON PUBLIC ACCESSIBILITY.....4

A. SCOPE OF THIS DECLARATION4

B. PERSON OF ORDINARY SKILL IN THE ART6

C. LIBRARY CATALOG RECORDS AND OTHER RESOURCES8

D. MONOGRAPH PUBLICATIONS15

IV. OPINION REGARDING AUTHENTICITY AND PUBLIC ACCESSIBILITY17

**A. DOCUMENT A: ARUNABHA GHOSH, ET AL., *FUNDAMENTALS OF LTE*. PRENTICE-HALL, 2011.
418 PAGES. (“GHOSH”)17**

**B. DOCUMENT B: HARRI HOLMA AND ANTTI TOSKALA, EDITORS. *LTE FOR UMTS: EVOLUTION
TO LTE-ADVANCED. 2D EDITION. WILEY, 2011. 543 PAGES. (“HOLMA”)26***

**C. DOCUMENT C: STEFANIA SESIA, ISSAM TOUFIK, AND MATTHEW BAKER, EDITORS. *LTE: THE
UMTS LONG TERM EVOLUTION FROM THEORY TO PRACTICE. 2D EDITION. WILEY, 2011.
 (“SESA”).....31***

V. AVAILABILITY FOR CROSS-EXAMINATION36

VI. RIGHT TO SUPPLEMENT37

VII. SIGNATURE37

I, James L. Mullins, PhD declare as follows:

I. INTRODUCTION

1. I have been retained in this matter by Apple Inc. (“Petitioner” or “Apple”) in the above-captioned *inter partes* review relating to U.S. Patent 9,509,440 to provide an opinion on a specific document.

2. I am presently Dean Emeritus of Libraries and Esther Ellis Norton Professor Emeritus at Purdue University. My career as a professional and academic/research spanned more than 44 years including library positions at Indiana University, Villanova University, Massachusetts Institute of Technology, and Purdue University. Appendix A is a true and correct copy of my curriculum vitae describing my background and experience.

3. In 2018, I founded the firm Prior Art Documentation Librarian Services, LLC, located at 205 St. Cuthbert, Williamsburg, VA 23188 after purchasing the intellectual property of and successor to Prior Art Documentation, LLC located at 711 South Race Street, Urbana, IL 61801. Further information about my firm, Prior Art Documentation Librarian Services, LLC (PADLS), is available at www.priorartdoelib.com.

4. I have been retained by Petitioner to offer my opinion on the authenticity and dates of public accessibility of various documents. For this service, I am being paid my usual hourly fee of \$275.00. I have no stake in the outcome of

this proceeding or any related litigation or administrative proceedings, and my compensation in no way depends on the substance of my testimony or the outcome of this proceeding.

II. BACKGROUND AND QUALIFICATIONS

5. I received a Bachelor of Arts degree in History, Religion and Political Science in 1972 as well as a Master of Arts degree in Library Science in 1973 from the University of Iowa. I received my Ph.D. in Academic Library Management in 1984 from Indiana University. Over the past forty-four years, I have held various positions and as a leader in the field of library and information sciences.

6. I am presently Dean Emeritus of Libraries and Esther Ellis Norton Professor Emeritus at Purdue University, and have been since January 1, 2018. I have been previously employed as follows:

- Dean of Libraries and Professor and Esther Ellis Norton Professor, Purdue University, West Lafayette, IN (2004-2017)
- Assistant/Associate Director for Administration, Massachusetts Institute of Technology (MIT) Libraries, Cambridge, MA (2000-2004)
- University Librarian and Director, Falvey Memorial Library, Villanova University, Villanova, PA (1996-2000)

- Director of Library Services, Indiana University South Bend, South Bend, IN (1978-1996)
- Part-time Instructor, School of Library and Information Science, Indiana University, Bloomington, IN (1979-1996)
- Associate Law Librarian, and associated titles, Indiana University School of Law, Bloomington, IN (1974-1978)
- Catalog Librarian, Assistant Professor, Georgia Southern College (now University), Statesboro, GA (1973-1974)

7. I am a member of the American Library Association (“ALA”), where I served as the chair of the Research Committee of the Association of College and Research Libraries (“ACRL”). My service to ALA included service on the editorial board of the most prominent library journal, *College and Research Libraries*. I also served on the Standards Committee, College Section of the Association of College and Research Libraries, where I was instrumental in developing a re-issue of the *Standards for College Libraries* in 2000.

8. I am an author of numerous publications in the field of library science, and have given presentations in library sciences at national and international conferences. During more than 44 years as an academic librarian and library science scholar, I have gained extensive experience with catalog records and online library management systems (LMS) built using Machine-Readable Cataloging

(“MARC”) standards. As an academic library administrator, I have had responsibility to ensure that students were educated to identify, locate, assess, and integrate information garnered from research library resources. I have also facilitated the research of faculty colleagues either directly or through the provision of and access to the requisite print and/or digital materials and services at the universities where I worked.

9. Based on my experience identified above and detailed in my curriculum vitae, which is attached hereto as Appendix A, I consider myself to be an expert in the field of library science and academic library administration. I have previously offered my opinions on the public availability and authenticity of documents in over 40 cases. I have been deposed in one case.

III. BACKGROUND ON PUBLIC ACCESSIBILITY

A. Scope of This Declaration

10. I am not a lawyer, and I am not rendering an opinion on the legal question of whether a particular document is, or is not, a “printed publication” under the law. I am, however, rendering my expert opinion on the authenticity of the document referenced herein and when and how this document was disseminated or otherwise made available to the extent that persons interested and ordinarily skilled in the subject matter or art, exercising reasonable diligence, could have located the document.

11. I am informed by counsel that an item is considered authentic if there is sufficient evidence to support a finding that the item is what it is claimed to be. I am also informed that authenticity can be established based on the contents of the document itself, such as the appearance, content, substance, internal patterns, or other distinctive characteristics of the item.

12. I am informed by counsel that a given reference qualifies as “publicly accessible” if it was disseminated or otherwise made available such that a person interested in and ordinarily skilled in the relevant subject matter could locate it through the exercise of ordinary diligence.

13. While I understand that the determination of public accessibility under the foregoing standard rests on a case-by-case analysis of the facts particular to an individual publication, I also understand that a printed publication is rendered “publicly accessible” if it is cataloged and indexed by a library such that a person interested in the relevant subject matter could locate it (*i.e.*, I understand that cataloging and indexing by a library is sufficient, though there are other ways that a printed publication may qualify as “publicly accessible”). One manner of sufficient indexing is indexing according to subject matter. I understand that it is not necessary to prove someone actually looked at the printed publication in order to show it was publicly accessible by virtue of a library’s cataloging and indexing thereof. I understand that cataloging and indexing by a single library of a single

instance of a particular printed publication is sufficient. I understand that, even if access to a library is restricted, a printed publication that has been cataloged and indexed therein is publicly accessible so long as a presumption is raised that the portion of the public concerned with the relevant subject matter would know of the printed publication. I also understand that the cataloging and indexing of information that would guide a person interested in the relevant subject matter to the printed publication, such as the cataloging and indexing of an abstract for the printed publication, is sufficient to render the printed publication publicly accessible.

14. I understand that evidence showing the specific date when a printed publication became publicly accessible is not necessary. Rather, routine business practices, such as general library cataloging and indexing practices, can be used to establish an approximate date on which a printed publication became publicly accessible.

B. Person of Ordinary Skill in the Art

15. In forming the opinions expressed in this declaration, I have reviewed the documents and appendices referenced herein. These materials are records created in the ordinary course of business by publishers, libraries, indexing services, and others. From my years of experience, I am familiar with the process for creating many of these records, and I know that these records are created by

people with knowledge of the information contained within the record. Further, these records are created with the expectation that researchers and other members of the public will use them. All materials cited in this declaration and its appendices are of a type that experts in my field would reasonably rely upon and refer to in forming their opinions.

16. I have been informed by counsel that the subject matter of this proceeding relates to the use of modulation and coding schemes in a wireless communication network.

17. I have been informed by counsel that a “person of ordinary skill in the art at the time of the inventions” (POSITA) is a hypothetical person who is presumed to be familiar with the relevant field and its literature at the time of the inventions. This hypothetical person is also a person of ordinary creativity, capable of understanding the scientific principles applicable to the pertinent field.

18. I have been informed by counsel that persons of ordinary skill in this subject matter or art would have included someone with a Master’s degree in Electrical Engineering, Computer Science, Applied Mathematics, Physics or equivalent and three to five years of experience working with wireless digital communication systems including physical layer of such systems, and that additional education might compensate for less experience, and vice-versa. It is my opinion that such a person would have been actively engaged in academic research

and learning through study and practice in the field, and possibly through formal instruction through the bibliographic resources relevant to his or her research. By the 2000s, such a person would have had access to a vast array of print resources, including at least the documents referenced below, as well as to a fast-changing set of online resources.

C. Library Catalog Records and Other Resources

19. Some background on MARC (Machine-Readable Cataloging) formatted records, OCLC, and *WorldCat* is helpful to understand the library catalog records discussed in this declaration. I am fully familiar with the library cataloging standard known as the MARC standard, which is an industry-wide standard method of storing and organizing library catalog information.¹ MARC practices have been consistent since the MARC format was developed by the Library of Congress in the 1960s, and by the early 1970s became the U.S. national standard for disseminating bibliographic data. By the mid-1970s, MARC format became the international standard, and persists through the present. A MARC-compatible library is one that has a catalog consisting of individual MARC records for each of its items. The underlying MARC format (computer program) underpins

¹ The full text of the standard is available from the Library of Congress at <http://www.loc.gov/marc/bibliographic/>.

the online public access catalog (OPAC) that is available to library users to locate a particular holding of a library. Today, MARC is the primary communications protocol for the transfer and storage of bibliographic metadata in libraries.² The MARC practices discussed below were in place during the 2000s time frame relevant to the documents referenced herein.

20. Online Computer Library Center (OCLC) is a not-for-profit worldwide consortium of libraries. Similar to MARC standards, OCLC's practices have been consistent since the 1970s through to the present. Accordingly, the OCLC practices discussed below were in place during the time frame discussed in my opinions

² Almost every major library in the world uses a catalog that is MARC-compatible. See, e.g., Library of Congress, *MARC Frequently Asked Questions (FAQ)*, <https://www.loc.gov/marc/faq.html> (last visited Jan. 24, 2018) ("MARC is the acronym for MACHine-Readable Cataloging. It defines a data format that emerged from a Library of Congress-led initiative that began nearly forty years ago. It provides the mechanism by which computers exchange, use, and interpret bibliographic information, and its data elements make up the foundation of most library catalogs used today."). MARC is the ANSI/NISO Z39.2-1994 (reaffirmed 2009) standard for Information Interchange Format.

section. OCLC was created “to establish, maintain and operate a computerized library network and to promote the evolution of library use, of libraries themselves, and of librarianship, and to provide processes and products for the benefit of library users and libraries, including such objectives as increasing availability of library resources to individual library patrons and reducing the rate of rise of library per-unit costs, all for the fundamental public purpose of furthering ease of access to and use of the ever- expanding body of worldwide scientific, literary and educational knowledge and information.”³ Among other services, OCLC and its members are responsible for maintaining the *WorldCat* database (<http://www.worldcat.org/>), used by libraries throughout the world.

21. Libraries worldwide use the machine-readable MARC format for catalog records. MARC-formatted records include a variety of subject access points based on the content of the document being cataloged. A MARC record for a particular work comprises several fields, each of which contains specific data about the work. Each field is identified by a standardized, unique, three-digit code

³ OCLC Online Computer Library Center, Inc., *Amended Articles of Incorporation of OCLC Online Computer Library Center, Inc.*, Third Article (OCLC, Dublin, Ohio) Revised November 30, 2016, <https://www.oclc.org/content/dam/oclc/membership/articles-of-incorporation.pdf>.

corresponding to the type of data that follows. For example, a work's title is recorded in field 245, the primary author of the work is recorded in field 100, a work's International Standard Book Number ("ISBN") is recorded in field 020, and the work's Library of Congress call number (assigned by Library of Congress) is recorded in field 050. Some fields can contain subfields, which are indicated by letters. For example, a work's publication date is recorded in field 260 under the subfield "c."

22. The MARC Field 040, subfield "a," identifies the library or other entity that created the catalog record in the MARC format. The MARC Field 008 identifies the date when this first MARC record was created. The MARC Field 005 identifies the most recent catalog activity including location assignment, by the holding library, that is, the library which owns the book and is identified in the OPAC.

23. MARC records also include several fields that include subject matter classification information. An overview of MARC record fields is available through the Library of Congress.⁴ For example, 6XX fields are termed "Subject Access Fields."⁵ Among these, for example, is the 650 field; this is the "Subject Added

⁴ See <http://www.loc.gov/marc/bibliographic/>.

⁵ See <http://www.loc.gov/marc/bibliographic/bd6xx.html>.

Entry – Topical Term” field.⁶ The 650 field is a “[s]ubject added entry in which the entry element is a topical term.” *Id.* The 650 field entries “are assigned to a bibliographic record to provide access according to generally accepted thesaurus-building rules (e.g., *Library of Congress Subject Headings* (LCSH), *Medical Subject Headings* (MeSH)).” *Id.* Thus, a researcher can easily discover material relevant to a topic of interest with a search using the terms employed in the MARC Fields 6XX.

24. Further, MARC records include call numbers, which themselves include a classification number. For example, the 050 field is dedicated as the “Library of Congress Call Number”⁷ as assigned by the Library of Congress. A defined portion of the Library of Congress Call Number is the classification number, and “source of the classification number is *Library of Congress Classification* and the *LC Classification-Additions and Changes*.” *Id.* Thus, included in the 050 field is a subject matter classification. As an example: TK5105.59 indicates books on computer networks – security measures. When a local library assigns a classification number, most often a Library of Congress derived classification number created by a local library cataloger or it could be a

⁶ See <http://www.loc.gov/marc/bibliographic/bd650.html>.

⁷ See <http://www.loc.gov/marc/bibliographic/bd050.html>.

Dewey Decimal classification number for example, 005.8, computer networks – security measures, it appears in the 090 field. In either scenario, the MARC record includes a classification number in the call number field that represents a subject matter classification.

25. The 9XX fields, which are not part of the standard MARC 21 format,⁸ were defined by OCLC for use by the Library of Congress, processing or holding notes for a local library, and for internal OCLC use. For example, the 955 field is reserved for use by the Library of Congress to track the progress of a new acquisition from the time it is submitted for Cataloging in Publication (CIP) review until it is published and fully cataloged and publicly available for use within the Library of Congress. Fields 901-907, 910, and 945-949 have been defined by OCLC for local use and will pass OCLC validation. Fields 905, 910, 980 etc., are often used by an individual library for internal processing purposes, for example the date of receipt or cataloging and/or the initials of the cataloger.

26. *WorldCat* is the world's largest public online catalog, maintained by the OCLC, a not-for-profit international library consortium, and built with the records created by the thousands of libraries that are members of OCLC. OCLC

⁸ See <https://www.oclc.org/bibformats/en/9xx.html>.

provides bibliographic and abstract information to the public based on MARC-compliant records through its OCLC *WorldCat* database. *WorldCat* requires no knowledge of MARC tags and code and does not require a login or password. *WorldCat* is easily accessible through the World Wide Web to all who wish to search it; there are no restrictions to be a member of a particular community, etc. The date a given catalog record was created (corresponding to the MARC Field 008) appears in some detailed *WorldCat* records as the Date of Entry but not necessarily all. *WorldCat* does not provide a view of the underlying MARC format for a specific *WorldCat* record. In order to see the underlying MARC format the researcher must locate the book in a holding library listed among those shown in *WorldCat*, and search the online public catalog (OPAC) of a holding library. Whereas *WorldCat* records are widely available, the availability of library specific MARC formatted records varies from library to library. When a specific library wishes to make the underlying MARC format available there will be a link from the library's OPAC display, often identified as a MARC record or librarian/staff view.

27. When a MARC record is created by the Library of Congress or an OCLC member institution, the date of creation for that record is automatically populated in the fixed field (008), with characters 00 through 05 in year, month, day

format (YYMMDD).⁹ Therefore, the MARC record creation date reflects the date on which the publication associated with the record was first cataloged. Thereafter, the local library's computer system may automatically update the date in field 005 every time the library updates the MARC record (*e.g.*, to reflect that an item has been moved to a different shelving location within the library, or a reload of the bibliographic data with the introduction of a new library management system that creates and manages the OPAC).

D. Monograph Publications

28. Monograph publications are written on a single topic, presented at length and distinguished from an article and include books, dissertations, and technical reports. A library typically creates a catalog record when the monograph is acquired by the library. First, it will search OCLC to determine if a record has already been created by the Library of Congress or another OCLC institution. If a record is found in OCLC, the record is downloaded into the library's LMS (Library Management System) that includes typically the OPAC (online public access catalog by which researchers locate a particular library holding in a user-friendly format), acquisitions, cataloging, and circulation integrated functions. Once the

⁹ Some of the newer library catalog systems also include hour, minute, second (HHMMSS).

item is downloaded into the library's LMS, the library adds its identifier to the OCLC database so when a search is completed on WorldCat, the library will be indicated as an owner of the title. Once a record is created in a Library's LMS, it is searchable and viewable through the library's OPAC, typically by author, title, and subject heading, at that library and from anywhere in the world through the internet by accessing that library's OPAC. The OPAC also connects with the circulation function of the library, which typically indicates whether the record is available, in circulation, etc., with its call number and location in a specific departmental/disciplinary library, if applicable. The OPAC not only provides immediate bibliographic access on-site, it also facilitates the interlibrary loan process, which is when one publication is loaned from one library to another.

29. ***O'Reilly Online Learning*** - O'Reilly learning provides individuals, teams, and businesses with expert-created and curated information covering all the areas that will shape our future—including artificial intelligence, operations, data, UX design, finance, leadership, and more.¹⁰

¹⁰ See <https://www.oreilly.com/online-learning/>.

30. **Google Books** - find a book, click on the “Buy this book” and “Borrow this book” links to see where it can be purchased as an e-book from the Google Play Store.¹¹

31. **Wisconsin TechSearch (WTS)** – WTS is a set of services offered by the University of Wisconsin Libraries. WTS offers an array of article delivery and research services to any retrieving information, regardless of whether the individual is affiliated with the University of Wisconsin.¹²

IV. OPINION REGARDING AUTHENTICITY AND PUBLIC ACCESSIBILITY

A. Document A: Arunabha Ghosh, et al., *Fundamentals of LTE*. Prentice-Hall, 2011. 418 pages. (“Ghosh”)

32. I have been asked to opine on a book authored by Arunabha Ghosh, et al, *Fundamentals of LTE* published by Prentice-Hall in 2011, “Ghosh”. Ghosh contains 418 pages, 10 Chapters, and an Index.

33. I have evaluated Exhibit 1007, the Ghosh reference several ways: (1) by assessing scans of a print copy of Ghosh owned by the University of Notre Dame Libraries, provided to me at my request by the Wisconsin TechSearch (WTS) on January 21, 2021 (Attachment A-1); (2) by assessing a digital copy accessed through

¹¹ See <https://books.google.com/googlebooks/about/index.html>.

¹² See (<https://wts.wisc.edu/>).

Purdue University Libraries (Attachment B-1) from the *O'Reilly Online Learning*;
(3) by purchasing a digital copy of Ghosh through Kindle (Attachment C-1); and
(4) accessing and assessing the OPAC and MARC records for Ghosh at the Library
of Congress (Attachments H-1 and Attachment I-1).

34. Attachment A-1 is the scan provided to me at my request from the
University of Notre Dame Libraries by the Wisconsin Tech Search (WTS) on January
21, 2021. Attachment A-1 includes: Cover; title page; copyright page with
handwritten call number that reads “Engin TK5103.48325.F86 2011; Contents,
includes pages: ix-xvi.

35. All identifying characteristics, such as stamps and notations on
Attachment A-1 are consistent with library practice and procedure that I have
observed during my career as a professional librarian. I have no cause for concern
about the authenticity or accuracy of these identifying attributes. In addition,
Attachment A-1 was found within the custody of a research library, the University
of Notre Dame Libraries, one of the most likely locations for an authentic
publication to be located.

36. Attachment B-1 are screenshots from Ghosh that include: cover; title
page; copyright page; and contents. This digital version was accessible to me from
the *O'Reilly Online Learning* database through Purdue University Libraries, and
was downloaded on January 27, 2021, due to license limitations it was not

possible to download Ghosh in its entirety from *O'Reilly Online Learning*,¹³
hence the reason for screen shots.

37. Attachment C-1 is screenshots from *Google Books*. I purchased a digital copy of Ghosh through *Google Books* on January 26, 2021. It was downloaded to my Kindle platform. I did call up the copy that I downloaded to compare the content of Ghosh purchased from *Google Books* and the copy I accessed through Purdue University Libraries from *O'Reilly Online Learning*.

38. The digital version of Ghosh is available to anyone for a fee through *Google books*.¹⁴

39. To verify authenticity of Attachment A-1, Attachment B-1, and Attachment C-1, I assessed the title page, copyright page and table of contents, from all three, they are identical. Having located Ghosh in a research library, University of Notre Dame Libraries, and in a publisher data base, *O'Reilly Online Learning*,

¹³ See <https://learning.oreilly.com/library/view/fundamentals-of-lte/9780137033638/title.html>

¹⁴ See https://www.google.com/books/edition/_/HjxmKq5MABcC?hl=en&gbpv=1&pg=PT21&dq=Fundamentals+of+LTE+

and a digital copy through *Google Books*, I can verify that Ghosh is an authentic document published by Prentice-Hall in 2011 in print and made available in digital format.

40. I conclude and affirm that Ghosh is an authentic document.

Public Accessibility

41. Attachment D-1 is the University of Notre Dame Library OPAC (online catalog) record that I downloaded on January 20, 2021. The document cataloged in this record is Ghosh as verified by author: Arunabha Ghosh; title: *Fundamentals of LTE*; publisher and publication date: Prentice Hall in 2011; and ISBN: 978-0-13-703311-9.

42. I also compared the LC Classification (call number): TK5103.48325.F86 2011 with that handwritten on the copyright pages of Attachment A-1 and it is the same on both, and on the OPAC record it indicates it is available in the “Lower Level Engineering Collection” also identified as a part of the call number. Ghosh could have been located by searching on the University of Notre Dame Libraries OPAC for the author: Arunabha Ghosh; title: *Fundamentals of LTE*; or by searching the subject heading: *Long-term Evolution (Telecommunications)*.

43. As mentioned above the MARC Field 005 and 9XX often indicate the date of receipt and cataloging, depending upon the practice and procedure of the

library. Attachment E-1 is a download I made on January 20, 2021 of the MARC record from the University of Notre Dame Libraries OPAC through the link: “Staff MARC View.” It provides detailed information about the ordering/receipt/cataloging/indexing of Ghosh.

44. In Attachment E-1, the MARC 980 Field is: 20101018 (October 18, 2010) and the MARC 005 Field is: 20101202123027, i.e., December 2, 2010 (the remaining digits are check digits).

45. I contacted Diane Walker, University Librarian, University of Notre Dame on January 22, 2021, to ask for clarification on the MARC 005 and MARC 980 fields as used by the University of Notre Dame Libraries, specifically for the MARC record for Ghosh.

46. Attachment F-1, is the email I received from Diane Walker, University Librarian of the University of Notre Dame on January 24, 2021. In her email she included an email to her from the head of Metadata Services of the University of Notre Dame in which she describes the policy and practice of the Metadata Department on the use of the MARC 005 and MARC 980 fields:

Here is a summary of what happened with this title:

10/18/2010: Title invoiced by vendor and item prepared to ship from vendor.

10/29/2010: Bibliographic record loaded in Aleph system and order record created automatically using the local 9XX MARC data. Shipment arrives in library

Acquisitions sometime around this date. After which, the shipment is unpacked, displayed for a two-week subject librarian review, taken off display for final invoice processing, and sent to Cataloging for final processing (just prior to Thanksgiving, I would guess).

12/2/2010: Cataloging of book is completed and it is sent to Labelling and delivery to the Engineering Library. This date corresponds to the MARC 005.

47. From Attachment E-1 and verified in Attachment F-1, the date in the MARC 005 Field is the final cataloging of Ghosh at the University of Notre Dame Libraries, December 2, 2010. Consistent with library practice and procedures I witnessed during my professional work as a librarian, Ghosh would have been available for public access within one week to ten days after it finished processing (labeling and transfer to the shelf) at the University of Notre Dame Libraries in the Engineering Collection on December 12, 2010.

48. Attachment G-1 is a download from *WorldCat* for holdings of Ghosh when searched using the geographical location of Indiana. The University of Notre Dame, Hesburgh Library was second among the 199 libraries shown as holding Ghosh worldwide.

49. Attachment G-1 shows that Ghosh is the document associated with this *WorldCat* entry, as verified by the author: Arunabha Ghosh, with the title: *Fundamentals of LTE*; and ISBN: 978-0-13-703311-9.

50. Ghosh could have been located by searching for the editors – Arunabha Ghosh; title: *Fundamentals of LTE*; or by searching the subject heading: *Long-term Evolution (Telecommunications)*.

51. The search discussed above could have been performed anywhere in the world by anyone who accessed *WorldCat* and its predecessor database through an OCLC member,

52. Attachment H-1 is a true and correct copy of the Library of Congress OPAC (online catalog) record and Attachment I-1 is the true and correct copy of the MARC record for Ghosh. Typically, I would have had scans of the copy of the print copy of Ghosh owned by the Library of Congress, however, due to the pandemic, the Library of Congress has been and remains closed at the time of this declaration and, hence, I am unable to obtain scans of Ghosh owned by the Library of Congress. Therefore, I will draw upon the OPAC and MARC records to verify the ownership, date of receipt and availability of Ghosh at the Library of Congress. As described above, the Library of Congress reserved the MARC 955 field to describe the receipt, cataloging and processing of items added to the collections of the Library of Congress. The MARC record is a record created and maintained by federal employees of the Library of Congress.

53. In Attachment H-1 the document cataloged in this record is *Fundamentals of LTE* as verified by the fields listing author: Arunabha Ghosh; title:

Fundamentals of LTE; publisher and publication date: Prentice Hall in 2011 and ISBN: 978-0-13-703311-9.

54. Ghosh could have been located in the Library of Congress OPAC by searching for the author: Arunabha Ghosh; title: *Fundamentals of LTE*; or by searching the subject heading: *Long-Term Evolution (Telecommunications)*.

55. Attachment I-1 is the MARC record I downloaded from the Library of Congress OPAC. The MARC format provides information about the processing of Ghosh by the Library of Congress. As mentioned above, the 9XX field in the MARC format is allocated to local libraries to enter information specific to that library. The Library of Congress has reserved the 955 field to indicate date of receipt of the published book and cataloging.

The MARC 955 field in this record reads:

955__ |b rc02 2011-02-15 z-processor |i rc02 2011-02-15 to BCCD |t rf18
2011-04-14 copy 2 added.

56. The 955 record indicates the processing Ghosh began 2011-02-15 (February 15, 2011) and finished processing on 2011-02-15 (February 15, 2011). The physical copy of Ghosh at the Library of Congress, consistent with library practice and procedures I witnessed during my professional work as a librarian, Ghosh would have been available for public access within one week to ten days after it finished processing (labeling and transfer to the shelf) on 2011-02-15 (February

15, 2011), therefore, Ghosh would have been available at the Library of Congress no later than February 25, 2011.

57. Ghosh was then accessible through Library of Congress OPAC. Once Ghosh was entered into the general collection of the Library of Congress, members of the public could access the book by having it brought to either the Jefferson or Adams Reading Rooms. The collections of the Library of Congress are searchable by subject matter, author, or title such that a skilled researcher could find works in which they were interested. For example, a member of the public could have located a copy of Ghosh by searching for the authors: Arunabha Ghosh, et al; title: *Fundamentals of LTE* and for the subject field *Long-Term Evolution (Telecommunications)* in MARC field 650 in the Library of Congress OPAC. Members of the public could read, study, and make notes about a selected work in the Reading Rooms. Further, members of the public were permitted to make photocopies of portions of the works while in the Reading Rooms. Accordingly, a copy of Ghosh was accessible to the general public when it was available at the Library of Congress.

58. Attachment J-1, a *WorldCat* entry for Ghosh. I obtained by completing a search on *WorldCat* on January 28, 2021. When I searched *WorldCat* for holdings of Ghosh in the District of Columbia, Library of Congress was second on the list among the 199 libraries shown as holding Ghosh worldwide.

59. Attachment J-1 shows that Ghosh is the document associated with this *WorldCat* entry, as verified by the authors: by Arunabha Ghosh, et al, with the title *Fundamentals of LTE* published by Prentice-Hall in 2011; and ISBN: 978-0-13-703311-9.

60. Ghosh could have been located by searching for the author – Arunabha Ghosh, et al, with the title *Fundamentals of LTE*; or by searching the subject heading: *Long-term Evolution (Telecommunications)*.

61. The search discussed above could have been performed anywhere in the world by anyone who accessed *WorldCat* and its predecessor database through an OCLC member,

Conclusion

62. I conclude that Ghosh is an authentic document and would have been publicly accessible through the University of Notre Dame Libraries no later than December 12, 2010, and the Library of Congress no later than February 25, 2011.

B. Document B: Harri Holma and Antti Toskala, editors. *LTE for UMTS: Evolution to LTE-Advanced. 2d edition. Wiley, 2011. 543 Pages. (“Holma”)*

Authentication

63. I have been asked to opine on a book edited by Harri Holma and Antti Toskala titled *LTE for UMTS. Evolution to LTE-Advanced. 2d edition*, published by Wiley in 2011. Holma contains 543 pages, 13 Chapters, and an Index.

64. I have evaluated the Holma reference several ways: (1) by assessing Holma, Exhibit 1013, provided to me by counsel; (2) by downloading Holma from the *Wiley Online Library* through the Purdue University Libraries; and (3) by accessing and reviewing the OPAC and MARC records for Holma at the Library of Congress.

65. Attachment A-2 is a download of Holma that includes the entire book. This digital version was accessible to me from the *Wiley Online Library* through Purdue University Libraries, and was downloaded on February 5, 2021.¹⁵

66. The digital version of Holma is available to anyone for a fee through the *Wiley Online Library*.¹⁶

67. Attachment B-2 is a true and correct copy of the Library of Congress OPAC (online catalog). Typically, I would have had scans of the print copy of Holma owned by the Library of Congress, however, due to the pandemic, the

¹⁵ See <https://onlinelibrary-wiley-com.ezproxy.lib.purdue.edu/doi/pdf/10.1002/9781119992943>.

¹⁶ See https://www.google.com/books/edition/LTE_for_UMTS/X9XwEOxYnAkC?hl=en&gbpv=1&dq=LTE+for+UMTS.+Evolution+to+LTE-Advanced.&pg=PP11&printsec=frontcover

Library of Congress has been and remains closed at the time of this declaration and hence, I am unable to obtain scans of Holma owned by the Library of Congress. Therefore, I will draw upon the OPAC and MARC records to verify the ownership, date of receipt and availability of Holma at the Library of Congress.

68. In Attachment B-2 the document cataloged in this record is as verified *LTE for UMTS. Evolution to LTE-Advanced. 2d edition.* by the fields listing main title: *LTE for UMTS. Evolution to LTE-Advanced. 2d edition.*; publisher and publication date: John Wiley in 2011 and ISBN: 9780470660003.

69. Holma could have been located in the Library of Congress OPAC by searching for the editors: Harri Holma and Antti Toskala; title: LTE for UMTS. Evolution to LTE-Advanced. 2d edition; or by searching the subject headings: Universal Mobile Telecommunication Systems; Wireless Communication Systems- Standards; Mobile Communication Systems – Standards; Global System for Mobile Communications and/or Long-Term Evolution (Telecommunications).

70. To verify authenticity of Attachment A-2 and Attachment B-2, I assessed the title page, copyright page and table of contents, from both, they are identical. Having located Holma in a research library, the Library of Congress, and in a publisher data base, *Wiley Online Library*, I can verify that Holma is an authentic document published by Wiley in 2011 in print and also made available in digital format.

71. I conclude and affirm that Holma is an authentic document.

Public Accessibility

72. Attachment C-2 is the MARC record I downloaded from the Library of Congress OPAC. The MARC format provides information about the processing of Holma by the Library of Congress. As mentioned above, the 9XX field in the MARC format is allocated to local libraries to enter information specific to that library. The Library of Congress has reserved the 955 field to indicate date of receipt of the published book and cataloging/indexing. The MARC record is a record created and maintained by Federal employees of the Library of Congress.

The MARC 955 field in this record reads:

955__ |b rg11 2010-11-29 (telework) |c rg11 2010-11-29 ONIX (telework)
to Gen Sci/Tech (STM) |d xh12 2010-12-29 |w rd11 2010-12-29 |a xe07
2011-06-02 1 copy rec'd., to CIP ver. |f rf08 2011-06-21 to BCCD

73. The 955 record indicates the processing Holma began 2010-11-29 (November 29, 2010) and finished processing on 2011-06-21 (June 21, 2011). The physical copy of Holma at the Library of Congress would have been available for public access within one week to ten days, consistent with library practice and procedures I witnessed during my professional work as a librarian, after it finished processing (labeling and transfer to the shelf) on June 21, 2011, therefore, Holma would have been available at the Library of Congress no later than July 1, 2011.

74. Holma was then accessible through Library of Congress OPAC. Once Holma was entered into the general collection of the Library of Congress, members of the public could access the book by having it brought to either the Jefferson or Adams Reading Rooms. The collections of the Library of Congress are searchable by subject matter, author, or title such that a skilled researcher could find works in which they were interested. For example, a member of the public could have located a copy of Holma by searching for the editors: Harri Holma and Antti Toskala; title; *LTE for UMTS. Evolution to LTE-Advanced*; **or** searching the subject headings: Universal Mobile Telecommunication Systems; Wireless Communication Systems- Standards; Mobile Communication Systems – Standards; Global System for Mobile Communications and/or Long-Term Evolution (Telecommunications).

75. Members of the public could read, study, and make notes about a selected work in the Reading Rooms. Further, members of the public were permitted to make photocopies of portions of the works while in the Reading Rooms. Accordingly, a copy of Holma was accessible to the general public when it was available at the Library of Congress.

76. Attachment D-2, the WorldCat entry for Holma, I obtained by completing a search on WorldCat on February 5, 2021. Attachment D-2 shows that Holma is the document associated with this *WorldCat* entry, as verified by the

editors: Harri Holma and Antti Toskala, with the title: *LTE for UMTS. Evolution to LTE-Advanced*; and by ISBN: 9780470660003.

77. When I searched WorldCat for holdings of Holma in the District of Columbia, Library of Congress was sixth on the among the 690 libraries shown as holding Holma worldwide.

78. The search discussed above could have been performed anywhere in the world by anyone who accessed WorldCat and its predecessor database through an OCLC member,

Conclusion

79. I conclude that Holma is an authentic document and would have been publicly accessible through the Library of Congress no later than July 1, 2011.

C. Document C: Stefania Sesia, Issam Toufik, and Matthew Baker, editors. *LTE: The UMTS Long Term Evolution from Theory to Practice*. 2d edition. Wiley, 2011. (“Sesia”)

Authentication

80. I have been asked to opine on a book edited by Stefania Sesia, Issam Toufik, and Matthew Baker titled. *LTE: The UMTS Long Term Evolution from Theory to Practice*. 2d edition. published by Wiley in 2011. Sesia contains in 752 pages, 32 Chapters, and an Index.

81. I have evaluated the Sesia reference several ways: (1) by assessing Sesia, Exhibit 1008, provided to me by counsel; (2) by downloading Sesia from

the *Wiley Online Library* through the Purdue University Libraries; and (3) by accessing and reviewing the OPAC and MARC records for Sesia at the Library of Congress. Attachment A-3 is a download of Sesia that includes the entire book. This digital version was accessible to me from the *Wiley Online Library* through Purdue University Libraries, and was downloaded on February 5, 2021.¹⁷

The digital version of Sesia is available to anyone for a fee through the *Wiley Online Library*.¹⁸

82. Attachment B-3 is a true and correct copy of the Library of Congress OPAC (online catalog). Typically, I would have had scans of the print copy of Sesia owned by the Library of Congress, however, due to the pandemic, the Library of Congress has been and remains closed at the time of this declaration and hence, I am unable to obtain scans of Sesia owned by the Library of Congress. Therefore, I

¹⁷ See <https://onlinelibrary-wiley-com.ezproxy.lib.purdue.edu/doi/pdf/10.1002/9780470978504>.

¹⁸ See https://www.google.com/books/edition/LTE_The_UMTS_Long_Term_Evolution/g0lficnQ6eUC?hl=en&gbpv=1&dq=LTE+-+the+UMTS+long+term+evolution+%5Belectronic+resource%5D+:+from+theory+to+practice&pg=PR21&printsec=frontcover.

will draw upon the OPAC and MARC records to verify the ownership, date of receipt and availability of Sesia at the Library of Congress.

83. In Attachment B-3 the document cataloged in this record is as verified by the fields listing under personal name: Sesia, Stefania; title: *LTE: The UMTS Long Term Evolution from Theory to Practice. 2d edition.* published by Wiley in 2011 and ISBN: 9780470660256.

84. Sesia could have been located in the Library of Congress OPAC by searching for the editors: Stefania Sesia, Issam Toufik, and Matthew Baker; title: *LTE: The UMTS Long Term Evolution from Theory to Practice* and/or by the following subject headings: *Universal Mobile Telecommunication Systems; and/or Long-Term Evolution (Telecommunications).*

85. To verify authenticity of Attachment A-3 and Attachment B-3, I assessed the title page, copyright page and table of contents, from both, they are identical. Having located Sesia in a research library, the Library of Congress, and in a publisher data base, *Wiley Online Library*, I can verify that Sesia is an authentic document published by Wiley in 2011 in print and also made available in digital format.

86. I conclude and affirm that Sesia is an authentic document.

Public Accessibility

87. Attachment C-3 is the MARC record I downloaded from the Library of Congress OPAC. The MARC format provides information about the processing of Sesia by the Library of Congress. As mentioned above, the 9XX field in the MARC format is allocated to local libraries to enter information specific to that library. The Library of Congress has reserved the 955 field to indicate date of receipt of the published book and cataloging/indexing. The MARC record is a record created and maintained by Federal employees of the Library of Congress.

The MARC 955 field in this record reads:

955__ |b xj12 2010-09-14 |c xj12 2010-09-14 ONIX (telework) to STM |w
rd11 2010-10- 19 |a xn02 2011-11-21 2 copies rec'd., to CIP ver. |f xj16
2012-04-10 copy 1 and 2 to BCCD

88. The 955 record indicates the processing Sesia began 2010-09-14 (September 14, 2010) and finished cataloging/processing on 2012-04-10 (April 4, 2012). The physical copy of Sesia at the Library of Congress would have been available for public access within one week to ten days, consistent with library practice and procedures I witnessed during my professional work as a librarian, after it finished processing (labeling and transfer to the shelf) on April 4, 2012, therefore, Sesia would have been available at the Library of Congress no later than April 14, 2012.

89. Sesia was then accessible through Library of Congress OPAC. Once Sesia was entered into the general collection of the Library of Congress, members of the public could access the book by having it brought to either the Jefferson or Adams Reading Rooms. The collections of the Library of Congress are searchable by subject matter, author, or title such that a skilled researcher could find works in which they were interested. For example, a member of the public could have located a copy of Sesia by searching for the editors: Stefania Sesia, Issam Toufik, and Matthew Baker; title: *LTE: The UMTS Long Term Evolution from Theory to Practice* and/or by the following subject headings: *Universal Mobile Telecommunication Systems; and/or Long-Term Evolution (Telecommunications)*.

90. Members of the public could read, study, and make notes about a selected work in the Reading Rooms. Further, members of the public were permitted to make photocopies of portions of the works while in the Reading Rooms. Accordingly, a copy of Sesia was accessible to the general public when it was available at the Library of Congress.

91. Attachment D-3, the WorldCat entry for Sesia, I obtained by completing a search on WorldCat on February 5, 2021. Attachment D-3 shows that Sesia is the document associated with this *WorldCat* entry, as verified by the editors: Stefania Sesia, Issam Toufik, and Matthew Baker; title: *LTE: The UMTS Long Term Evolution from Theory to Practice* and by ISBN: 9780470660256

92. When I searched WorldCat for holdings of Sesia in the District of Columbia, the Library of Congress was sixth on the among the 770 libraries shown as holding Sesia worldwide.

93. The search discussed above could have been performed anywhere in the world by anyone who accessed WorldCat and its predecessor database through an OCLC member.

Conclusion

94. I conclude that Sesia is an authentic document and would have been publicly accessible through the Library of Congress no later than April 14, 2012.

V. AVAILABILITY FOR CROSS-EXAMINATION

95. In signing this Declaration, I recognize that this Declaration will be filed as evidence in a contested case before the Patent Trial and Appeal Board of the U.S. Patent and Trademark Office. I also recognize that I may be subject to cross-examination in the case and that cross-examination will take place within the United States. If cross-examination is required of me, I will appear for cross-examination within the United States during the time allotted for cross-examination.

VI. RIGHT TO SUPPLEMENT

96. I reserve the right to supplement my opinions in the future to respond to any arguments that the Patent Owner raises and to take into account new information as it becomes available to me.

VII. SIGNATURE

97. I declare that all statements made herein of my own knowledge are true and that all statements made on information and belief are believed to be true; and further that these statements were made with the knowledge that willful false statements and the like so made are punishable by fine or imprisonment, or both, under Section 1001 of Title 18 of the United States Code.

98. I declare under penalty of perjury that the foregoing is true and correct.

Dated: December 13, 2021

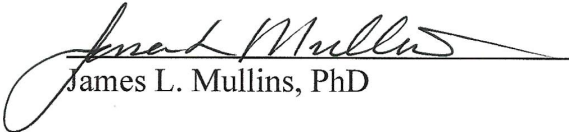
James L. Mullins, PhD

Appendix A

JAMES L. MULLINS, PhD

Prior Art Documentation Librarian Services, LLC

205 Saint Cuthbert, Williamsburg, VA 23188

jlmullins@priorartdoclib.com

ph. 765 479 4956

Prior Art Documentation Librarian Services, LLC. (PADLS). Founded January 2018. As of December, 2021, 112 declarations have been completed for 38 law firms; four depositions scheduled, three cancelled a few days prior, and one was held, and was successful for my client.

Library Experience:

- 2018-present** Dean Emeritus of Libraries & Esther Ellis Norton Professor Emeritus.
- 2011 - 2017** Dean of Libraries & Esther Ellis Norton Professor, Purdue University.
- 2004 - 2011** Dean of Libraries & Professor, Purdue University.
- 2000 - 2004** Assistant/Associate Director for Administration, MIT Libraries, Massachusetts Institute of Technology.
- 1996 - 2000** University Librarian & Director, Falvey Memorial Library. Villanova University.
- 1978 - 1996** Director of Library Services, Indiana University South Bend.
- 1974 - 1978** Associate Librarian, Indiana University Bloomington, School of Law.
- 1973 - 1974** Instructor/Catalog Librarian. Georgia Southern College (now University).

Teaching Experience:

- 1977 - 1996** Associate Professor (part-time), School of Library and Information Science, Indiana University. Subjects taught: Cataloging, Management, and Academic Librarianship.

Education:

- The University of Iowa. Honors Bachelor of Arts in History, Religion & Political Science, 1972.**
- The University of Iowa. Master of Arts in Library Science, 1973.**
- Indiana University. Doctor of Philosophy. Concentration: Academic Library Administration. Emphasis: Law Librarianship, 1984.**

Awards and Recognition:

2017 Wilmeth Active Learning Center/Library of Engineering and Science, Grand Reading Room, was announced by President Mitch Daniels, Purdue University, that it would be re-named the James L. Mullins Reading Room to honor his leadership and reputation in the academic library profession. September 2017. Portrait unveiled December 2017.

2017 Distinguished Alumnus Award by the School of Informatics and Computing, Indiana University, Bloomington. Given June 25, 2017.

2016 Hugh C. Atkinson Memorial Award, jointly sponsored by the four divisions of the American Library Association (ALA), June 27, 2016.

2015 ACRL Excellence in University Libraries Award, April 23, 2015.

Named Esther Ellis Norton Professor of Library Science by Purdue Trustees, December 11, 2011.

International Review Panel to evaluate the University of Pretoria Library, February 20 – 24, 2011. Pretoria, South Africa.

Publications: (selected)

“An Academic ‘Ecotone’: The Wilmeth Active Learning Center, Purdue University” to be published in *Designing Academic Libraries*, Association of College and Research Libraries, 2022.

A Purdue Icon: creation, life, and legacy, edited by James L. Mullins, Founder’s Series, Purdue University Press, 138pp., August 2017.

“The policy and institutional framework.” In *Research Data Management, Practical Strategies for Information Professionals*, edited by Ray, J M. Purdue University Press, pp.25-44, 2014.

“DataCite: linking research to data sets and content.” In Benson, P and Silver, S. *What Editors Want: An Author’s Guide to Scientific Journal Publishing*. University of Chicago Press, pp. 21-23, December 2012.

“Library Publishing Services: Strategies for Success,” with R. Crow, O. Ivins, A. Mower, C. Murray-Rust, J. Ogburn, D Nesdill, M. Newton, J. Speer, C. Watkinson. *Scholarly Publishing and Academic Resources Coalition (SPARC)*, version 2.0, March 2012.

“The Changing Definition and Role of Collections and Services in the University Research Library.” *Indiana Libraries*, Vol 31, Number 1 (2012), pp.18-24.

“Are MLS Graduates Being Prepared for the Changing and Emerging Roles that Librarians must now assume within Research Libraries?” *Journal of Library Administration*. Volume 52, Issue 1, 2012, p. 124-132

Baykoucheva, Svetla. What Do Libraries Have to Do with e-Science?: An Interview with James L. Mullins, Dean of Purdue University Libraries. *Chem. Inf. Bull.* [Online] 2011, 63 (1), 45-49.
<http://www.acscinf.org/publications/bulletin/63-1/mullins.php> (accessed Mar 16, 2011).

“The Challenges of e-Science Data-set Management and Scholarly Communication for Domain Sciences and Technology: a Role for Academic Libraries and Librarians,” chapter in, *The Digital Deluge: Can Libraries Cope with e-Science?*” Deanna B. Marcum and Gerald George, editors, Libraries Unlimited/Teacher Ideas Press, 2009. (a monograph publication of the combined proceedings of the KIT/CLIR proceedings).

“Bringing Librarianship to e-Science,” *College and Research Libraries*. vol. 70, no. 3, May 2009, editorial.

“The Librarian’s Role in e-Science” *Joho Kanri (Journal on Information Processing and Management)*, Japan Science and Technology Agency (formerly Japan Information Center of Science and Technology), Tokyo, Japan. Translated into Japanese by Taeko Kato. March 2008.

The Challenge of e-Science Data-set Management to Domain Sciences and Engineering: a Role for Academic Libraries and Librarians,” KIT (Kanazawa Institute of Technology)/CLIR (Council of Library and Information Resources) International Roundtable for Library and Information Science, July 5-6, 2007. Developments in e-science status quo and the challenge, The Japan Foundation, 2007.

“An Administrative Perspective,” Chapter 14, *Proven Strategies for Building an Information Literacy Program*, Susan Curzon and Lynn Lampert, editors, Neal-Schuman Publishers, Inc., New York, 2007. pp. 229-237.

Library Management and Marketing in a Multicultural World, proceedings of the IFLA Management and Marketing (M&M) Section, Shanghai, China, August 16-17, 2006, edited. K.G. Saur, Munchen, Germany, June 2007. 390 pp.

Top Ten Assumptions for the Future of Academic Libraries and Librarians: a report from the ACRL Research Committee, with Frank R. Allen and Jon R. Hufford. *College & Research Libraries*, April 2007, vol.68, no.4. pp.240-241, 246.

To Stand the Test of Time: Long-term Stewardship of Digital Data Sets in Science and Engineering. A report to the National Science Foundation from the ARL Workshop on New Collaborative Relationships: the Role of Academic Libraries in the Digital Data Universe. September 26-27, 2006, Arlington, VA. p.141. <http://www.arl.org/bm~doc/digdatarpt.pdf>

“Enabling Interaction and Quality in a Distributed Data DRIS,” *Enabling Interaction and Quality: Beyond the Hanseatic League*. 8th International Conference on Current Research Information Systems, with D. Scott Brandt and Michael Witt. Promoted by euro CRIS. Leuven University Press, 2006. pp.55-62. Editors: Anne Garns Steine Asserson and Eduard J. Simons.

"Standards for College Libraries, the final version approved January 2000," prepared by the ACRL College Libraries Standards Committee (member), *C&RL News*, March 2000, p.175-182.

"Standards for College Libraries: a draft," prepared by the ACRL College Libraries Section, Standards Committee (member), *C&RL News*, May 1999, p. 375-381.

"Statistical Measures of Usage of Web-based Resources," *The Serials Librarian*, vol. 36, no. 1-2 (1999) p. 207-10.

"An Opportunity: Cooperation between the Library and Computer Services," in *Building Partnerships: Computing and Library Professionals*. Edited by Anne G. Lipow and Sheila D. Creth. Berkeley and San Carlos, CA, Library Solutions Press, 1995. p. 69-70.

"Faculty Status of Librarians: A Comparative Study of Two Universities in the United Kingdom and How They Compare to the Association of College and Research Libraries Standards, " in *Academic Librarianship, Past, Present, and Future: a Festschrift in Honor of David Kaser*. Englewood, Colorado; Libraries Unlimited, 1989. p. 67-78. Review in: *College & Research Libraries*, vol. 51, no. 6. November 1990, p. 573-574.

Presentations: (Representative)

“How Long the Odyssey? Transitioning the Library and Librarians to Meet the Needs and Expectations of the 21st Century University,” David Kaser Lecture, School of Informatics & Computing, Indiana University, Bloomington, IN, November 16, 2015.

Presentation at University of Cape Town, Cape Town, South Africa, August 20, 2015.

“The Challenge of Discovering Science and Technology Information,” Moderator, International Federation of Library Associations (IFLA) Science and Technological Libraries Section Program, Cape Town, South Africa, August 18, 2015.

“An Odyssey in Data Management: Purdue University,” International Federation of Library Associations (IFLA) Research Data Management: Finding Our Role – A program of the Research Data Alliance, Cape Town, South Africa, August 17, 2015.

Presentation at University of Pretoria, Pretoria, South Africa, August 11, 2015.

Co-Convener with Sarah Thomas, Harvard University, at the Harvard Purdue Symposium on Data Management, Harvard University, Cambridge, MA, June 15-18, 2015.

“Strategic Communication,” panel discussion on the Director's role and perspective on library communications at Committee on Institutional Cooperation (CIC) Center for Library Initiatives (CLI) Annual Conference, University of Illinois Urbana-Champaign, May 20, 2015.

“Issues in Data Management,” panel discussion moderated by Catherine Woteki, United States Undersecretary for Research, Education & Economics at 20th Agriculture Network Information Collaborative (AgNIC) Annual Meeting in the National Agricultural Library, Beltsville, MD, May 6, 2015.

“Active learning/IMPACT & the Active Learning Center at Purdue University,” Florida Institute of Technology, Melbourne, FL, February 11, 2015.

“Science+art=creativity: libraries and the new collaborative thinking,” panel moderator, International Federation of Library Associations (IFLA) 80th General Conference and Assembly, Lyon, France, August 19, 2014.

“Purdue University The Active Learning Center—A new concept for a library,” Association of University Architects 59th Annual National Conference, University of Notre Dame, South Bend, IN, June 23, 2014.

“Big Data & Implications for Academic Libraries,” keynote speaker, Greater Western Library Alliance (GWLA) Cyber-infrastructure Conference, Kansas City, MO, May 28, 2014.

“Research Infrastructure,” panel moderator, Association of Research Libraries (ARL) 164th Membership Meeting, Ohio State University, Columbus, OH, May 7, 2014.

“An Eight Year Odyssey in Data Management: Purdue University,” International Association of Scientific and Technological University Libraries (IATUL) 2013 Workshop Research Data Management: Finding Our Role, University of Oxford, UK, December 2013.

“Purdue University Libraries & Press: from collaboration to integration,” Ithaka Sustainable Scholarship, The Evolving Digital Landscape: New Roles and Responsibilities in Higher Education, libraries as publishers, New York, New York, October 2013.

“Tsinghua and Purdue: Research Libraries for the 21st Century,” Tsinghua University, Tsinghua, China, August 2013.

“Purdue Publishing Experience in the Libraries Publishing Coalition,” Association of American University Presses Annual Meeting, Press-Library Coalition Panel, Boston, Massachusetts, June 21, 2013.

“Indiana University Librarians Day: Purdue University Libraries Ready for the 21st Century,” Indiana University Purdue University Indianapolis (IUPUI), June 7, 2013.

“Purdue University Libraries and Open Access; CNI Project Update,” Coalition for Networked Information, San Antonio, TX, April 5, 2013.

Memorial Resolution, honoring Joseph Brannon, to the Board of the Association of College & Research Libraries, Seattle, WA, January 2013.

“An overview of sustaining e-Science collaboration in an Academic Research Library—the Purdue experience,” Duraspace e-Science Institute webcast, October 17, 2012.

“The Role of Libraries in Data Curation, Access, and Preservation: an International Perspective,” Panel Moderator, 78th General Conference and Assembly, International Federation of Library Associations, Helsinki, Finland, August 15, 2012.

“21st Century Libraries,” moderator of First Plenary Session, International Association of Technological University Libraries 33rd Annual Conference, Singapore, June 4, 2012.

“Planning for New Buildings on Campus,” panel presenter, University of Calgary Building Symposium on Designing Libraries for the 21st Century, Calgary, Alberta, Canada, May 17, 2012.

“Data Management and e-Science, the Purdue Response.” Wiley-Blackwell Executive Seminar-2012, Washington, DC, March 23, 2012.

“An overview of Sustaining e-Science Collaboration in Academic Research Libraries and the Purdue Experience.” Leadership & Career Development Program Institute, Association of Research Libraries (ARL). Houston, TX, March 21, 2012.

“An overview of Data Activities at Purdue University in response to Data Management Requirements.” Coalition for Academic Scientific Computation (CASC). Arlington, VA, September 8, 2011.

“Getting on Track with Tenure,” Association of College and Research Libraries (ACRL) Research Program Committee. Washington, DC, June 26, 2011.

“Integration of the Press and Libraries Collaboration to Promote Scholarly Communication,” Association of Library Collections & Technical Services (ALCTS) Scholarly Communication Interest Group – American Library Association, New Orleans, Louisiana, June 25, 2011.

“Cooperation for improving access to scholarly communication,” with N. Lossau (Germany), C. Mazurek (Poland), J. Stokker (Australia), panel moderator and presenter, Second Plenary Session, International Association of Scientific and Technological University Libraries (IATUL) 32nd Conference 2011, Warsaw, Poland. May 29-June 2, 2011.

“Riding the Wave of Data,” STM Annual Spring Conference 2011. Trailblazing & transforming scholarly publishing 2011. Washington, D.C., April 28, 2011.

“Confronting old assumptions to assume new roles: physical and operational integration of the Press and Libraries at Purdue University,” keynote speaker, 2011 BioOne Publishers & Partners Meeting. Washington, D. C., April 22, 2011.

“Are MLS Graduates Being Prepared for the Changing and Emerging Roles that Librarians must now assume within Research Libraries?” University of Oklahoma Libraries Seminar, March 4, 2011, Oklahoma City, Oklahoma.

“The Future Role of University Librarians,” the University of Cape Town, South Africa, February 25, 2011.

“New Roles for Librarians: the Application of Library Science to Scientific/Technical Research – Purdue University – a case study. International Council for Science and Technology (ICSTI); Ottawa, Canada. June 9, 2009.

“Reinventing Science Librarianship: Models for the Future,” Association of Research Libraries / Coalition for Networked Information. October 16-17th, 2008, Arlington, VA. Moderator and convener of Data Curation: Issues and Challenges.

“Practical Implementation and Opportunities Created at Purdue University,” African Digital Curation Conference, Pretoria, South Africa, (live video transmission), February 12, 2008.

Keynote speaker. “*Scholarly Communication & Academe: The Winter of Our Discontent*,” XXVII Charleston Conference on Issues in Book and Serial Acquisition, Charleston, South Carolina. November 8, 2007.

Keynote speaker. “*Enabling Access to Scientific & Technical Data-sets in e-Science: a role for Library and Archival Sciences*,” Greater Western Library Alliance (GWLA), Tucson, Arizona. September 17, 2007. A meeting of library directors and vice presidents for research of member institutions.

“*The Challenge of e-Science Data-set Management to Domain Sciences and Engineering: a Role for Academic Libraries and Librarians*,” KIT (Kanazawa Institute of Technology)/CLIR (Council of

Library and Information Resources) International Roundtable for Library and Information Science, July 5-6, 2007. Invited to participate by the Deputy Librarian of Congress.

International Association of Technological University Libraries (IATUL), Stockholm, Sweden. June 8, 2007. Invited paper, *Enabling International Access to Scientific Data-sets: creation of the Distributed Data Curation Center (D2C2)*.

“A New Collaboration for Librarians: The Principles of Library and Archival Sciences Applied to the Curation of Datasets,” Symposium of the Libraries and the College of Engineering, University of Louisville, April 6, 2007.

“Purdue University Libraries: Through Pre-eminent Innovation and Creativity, Meeting the Challenges of the Information Age,” Board of Trustees, Purdue University, February 15, 2007.

ARL Workshop on New Collaborative Relationships: The Role of Academic Libraries in the Digital Data Universe, September 26-27, 2006, Arlington, VA. Invited participant.

NARA and SDSC: A partnership. A panel before the National Science Foundation, June 27, 2006. Arlington, VA. Invited participant.

“Kaleidoscope of Scientific Literacy: fusing new connections,” with Diane Rein, American Library Association, Association of College and Research Libraries, Science & Technology Section, Annual Conference, New Orleans, June 26th, 2006.

“Leadership for Learning: Building a Culture of Teaching in Academic Libraries – an administrative perspective,” American Library Association, Association of College and Research Libraries, Instruction Section, Annual Conference, New Orleans, June 25th, 2006.

“Building an interdisciplinary research program in an academic library:

how the Libraries’ associate dean for research makes a difference at Purdue University,” International Association of Technological University Libraries (IATUL), Porto, Portugal, May 23rd, 2006.

“Enabling Interaction and Quality in a Distributed Data DRIS,” *Enabling Interaction and Quality: Beyond the Hanseatic League*. 8th International Conference on Current Research Information Systems, with D. Scott Brandt and Michael Witt. Promoted by euro CRIS, Bergen, Norway, May 12th, 2006, Brandt, and Witt presented in person

“Interdisciplinary Research,” with D. Scott Brandt, Coalition for Networked Information (CNI) Spring Meeting: Project Briefing, Washington, D.C., April 3rd, 2006.

“An Interview with Purdue’s James Mullins,” a podcast submitted by Matt Pasiewicz, on *Educause Connect*, http://connect.educause.edu/James_L_Mullins_Interview_CNI_2005

“Managing Long-Lived Digital Data-sets and their Curation: Interdisciplinary Policy Issues,” Managing Digital Assets Forum, Association of Research Libraries (ARL), Washington, D.C., October 28th, 2005.
“The Odyssey of a Librarian.” Indiana Library Federation (ILF), District 2 Meeting, South Bend, Indiana. October 4th, 2005.

"New College Library Standards," Standards Committee Presentation, ALA, Chicago, July 7, 2000.
SUNY Library Directors, Lake George, New York. “*The College Library Standards: a Tool for Assessment.*” April 5, 2000.

Tri-State College Library Association, *Finding You Have Talents You Never Knew You Had*, Penn State Great Valley, March 25, 2000.

Using Web Statistics, American Library Association, New Orleans, June 24, 1999.

Keynote speaker at the JSTOR Workshop, January 29, 30, 1999. University of Pennsylvania, Philadelphia, PA.

"The New Standards for Electronic Resources Statistics," Society of Scholarly Publishers, Washington, D.C., September 17, 1998.

"Evaluating Online Resources: Now that you've got them what do you do?," joint presenter with Chuck Hamaker, LSU, at the NASIG Conference, Boulder, Colorado. June 1998.

"What Employers Are Looking for in New Librarians?" Pennsylvania Library Association, Philadelphia. September 26, 1997.

"The Theory of Matrix Management" panel presentation of the Comparative Library Organization Committee of the Library Organization and Management Section of the Library Administration and Management Association, a division of the American Library Association, Annual Meeting, Chicago, June 24, 1990.

Professional Involvement: (summary of recent emphasis)

The focus for my professional involvement and research has moved recently toward managing massive data-sets. This has resulted in working with faculty in the sciences and technology to determine how librarians can collaborate in managing, curating, and preserving data-sets for future access and documentation. This has included various speaking opportunities as well as participation in planning with the National Science Foundation (NSF) on ways in which librarians can be integrated more completely into the funded research process. Participation in the Kanazawa Institute of Technology/Council of Library Resources Roundtable was particularly rewarding and provided new opportunities to share with international colleagues the issues surrounding data-set management. I was

the champion for the creation of the Distributed Data Curation Center (D2C2) at Purdue University (<http://d2c2.lib.purdue.edu/>)

Throughout my career, beginning with my dissertation, I have been actively involved with assessing and evaluating libraries. In the fall of 1999, I contacted twenty-two academic library directors to determine whether the need was also felt by others. The response was overwhelmingly affirmative. This resulted in a meeting at ALA Midwinter, January 2000. A formal meeting followed at Villanova University in April 2000. As convener, I helped to form the University Libraries Group (ULG), modeled after the Oberlin Group for college libraries. The ULG is made up of university libraries that support diverse wide-ranging programs through doctoral level and have a level of support that places them in the top tier of academic institutions. A few of the member libraries, along with Villanova, are William and Mary, Wake Forest, Lehigh, Carnegie-Mellon, Tufts, Marquette, Miami of Ohio, and Southern Methodist. In 1994 appointed to the Standards Committee, College Section, Association of College and Research Libraries. During the next six years, the Committee concentrated on changing the focus of the standards from quantitative analysis of input and output factors to emphasis on assessment of the outcome. Culmination of the work was a re-issue of the *Standards for College Libraries* in 2000. The knowledge gained through my work experience enabled me to formulate the changes needed in the standards. This work allowed for close collaboration with accrediting agencies, both professional and regional. During this same time another focus emerged, the impact of digital resources. Through my work on the JSTOR Statistics Task Force, standards were developed on the collection of use of electronic databases. This Standard was later adopted in 1998 by the International Consortium of Library Consortia (ICOLC). In 2002, the American Library Association appointed me to serve as the liaison to the Marketing and Management Section of the International Federation of Library Associations (IFLA).

Professional Service: (representative list)

Nominations Committee, Association of Research Libraries (ARL), 2016.

Steering Committee, Scholarly Publishing and Academic Resources Coalition (SPARC), 2016 – 2017.

“Excellence in Library Services,” Chair, Review Team, University of Hong Kong, Hong Kong, August 24-27, 2015.

Chair, Management Advisory Board, 2015-2017; Member, Scientific Advisory Board, arXiv, Cornell University, 1/1/2013 – present.

Advisory Board for the Wayne State University School of Library and Information Science, July 2012 – present.

Advisory Board for Microsoft Academic Search, 2012 – 2015. Redmond, WA.

Transforming Research Libraries, a Strategic Direction Steering Committee of the Association of Research Libraries (ARL), 2012-2015.

Science and Technology section, representing ARL, International Federation of Library Associations (IFLA), Chair, 2013 – 2017; Member, 2011 to present.

Member of University of Pretoria, South Africa, Library Review Committee. August 2013.

Co-chair, Local Arrangements Planning Committee for 2013 Conference, Association of College and Research Libraries (ACRL), a division of the American Library Association (ALA).

Association of Research Libraries Leadership & Career Development Program Mentor, 2011-2017.

e-Science Task Force, Association of Research Libraries. July 2006 – present. Chair, October 2011 – October 2012.

Board of Directors, International Association of Technological University Libraries (IATUL). January 2008 – December 2014.

Midwest Collaborative for Library Services (MCLS); Board Member, October 2010 – December 2012.

Chair, Library Directors, Committee on Institutional Cooperation (CIC), July 2010 – June 2012.

Board of Directors, Association of Research Libraries (ARL); October 2008 – October 2011.

Scholarly Communication Steering Committee, Association of Research Libraries (ARL) 2008-2011.

Editorial Board, *College and Research Libraries*, Association of College and Research Libraries, American Library Association. January 2008 – December 2014.

Chair, Organizing Committee for IATUL Conference 2010, June 21-24, 2010, Purdue University, West Lafayette, Indiana/Chicago, Illinois.

Conference Planning Committee for National Conference of the Association of College and Research Libraries, 2009, Seattle, Washington.

Research Committee, Association of College and Research Libraries, ACRL, division of ALA. 2002-2007, chair, 2005-2007.

Association of Research Libraries, Search and Screen Committee, Executive Director. March – January 2008.

Center for Research Libraries, Board of Directors. April 2006 – April 2012.

Academic Libraries of Indiana, Board of Directors, 2004 – present. Vice-president, 2005-2007.

President, 2007- 2009.

ALA Representative to the International Federation of Library Associations (IFLA), Marketing and Management (M&M) Section, initial term 2003-2007, re-appointed for second term, 2007-2011.

Invited to represent Research Libraries at the ACRL/3M Womewok Retreat to assess Marketing of Academic Libraries, October 2002.

Hugh A. Atkinson Award Committee, LAMA Representative, ALA, 2001-2005.

Program Committee, Library Administrators and Management Association (LAMA), a division of ALA. 1996-2001.

ACRL, Standards and Accreditation Committee, a division of ALA. Liaison to RBMS Section of ACRL. 1997-2002.

Elected to the Executive Committee of LAMA, LOMS, a division of the American Library Association, 1998-2000. Nominated as Chair/Elect for 2003 – 2005.

Columbia University Press Advisory Committee. 1996 - 2000.

LITA/LAMA Conference Evaluation Committee, Pittsburgh, Pennsylvania, October 1996.

"New Learning Communities," Coalition for Networked Information, Indianapolis. November 19-21, 1995. Facilitator for invitational, national conference committed to developing collaborative learning and teaching techniques, involving librarians.

Planning Committee-Evaluation. LITA/LAMA 1996 Conference, Pittsburgh. This first conference, to be held jointly between two divisions of ALA, will focus on new technologies within libraries.

Indiana Cooperative Library Services Authority (InCoLSA), elected to Executive Committee, April 1991, served as President in 1993-94. InCoLSA is a statewide network of academic, public, school, and special libraries that supports library cooperation for cataloging, interlibrary loan, collection development and application of new technologies.

Governor's Conference on Libraries and Information Services. Served on Planning Committee, Academic Libraries Representative, appointed by the Governor to represent academic libraries in Indiana, Chair, Finance Committee, April 1989-July 1991.

Indiana Library Endowment Foundation Board, 1984-92. Charter Member, 1984, President, 1988-1992. 2004-2005.

University Service: (Summary)

Served on search and screen committees for senior positions including chancellor, dean, and directors; most recently I have been asked to serve on the search committee for the provost of Purdue University. At MIT service included the Library Council & appointment to the Administrative Council by President

Vest, 2001-2003 & Member of the Faculty Committee on the Library System. At Purdue appointed by the President to the Search Committee for the Provost, October 2007 to May 2008; member of the Capital Projects Committee, and IT Operational Oversight Committee as senior academic dean, 2008-2014.

Global Council, Global Policy Institute, 2012 – 2016.

Academic Program Excellence and Rankings (APER) project team, 2014.

Representative of the Academic Deans on the Re-engineering Business Operations, Purdue University, 2016 –

Academic Deans Council chaired by Provost – 2004 – 2017.

University Promotion and Tenure Committee – 2006 – 2017.

"Outstanding Team Award, Electronic Reserve Project," served as Chair, recognition awarded by the President of Villanova University to one team who made an outstanding contribution to the operations of the University, selected by a committee of administrators, faculty, and staff. Awarded September 9, 1999.

Nominated for the IUSB Lundquist Award, 1995 & 1996. The Lundquist award is given to faculty who have "exhibited excellence in teaching, scholarly or artistic achievement, and diversified relevant service..."

Attachment A-1

The logo for Prentice Hall, featuring a red grid of dots to the left of the text "PRENTICE HALL" in white, with "PRENTICE" on the top line and "HALL" on the bottom line.

PRENTICE
HALL

Fundamentals of **LTE**

Arunabha Ghosh • Jun Zhang
Jeffrey G. Andrews • Rias Muhamed

Foreword by Rajiv Laroia

Fundamentals of LTE

Arunabha Ghosh
Jun Zhang
Jeffrey G. Andrews
Rias Muhamed



PRENTICE
HALL

Upper Saddle River, NJ • Boston • Indianapolis • San Francisco
New York • Toronto • Montreal • London • Munich • Paris • Madrid
Capetown • Sydney • Tokyo • Singapore • Mexico City

Many of the designations used by manufacturers and sellers to distinguish their products are claimed as trademarks. Where those designations appear in this book, and the publisher was aware of a trademark claim, the designations have been printed with initial capital letters or in all capitals.

The authors and publisher have taken care in the preparation of this book, but make no expressed or implied warranty of any kind and assume no responsibility for errors or omissions. No liability is assumed for incidental or consequential damages in connection with or arising out of the use of the information or programs contained herein.

Credits and permissions appear on pages 417 and 418.

The publisher offers excellent discounts on this book when ordered in quantity for bulk purchases or special sales, which may include electronic versions and/or custom covers and content particular to your business, training goals, marketing focus, and branding interests. For more information, please contact:

U.S. Corporate and Government Sales
(800) 382-3419
corpsales@pearsontechgroup.com

For sales outside the United States please contact:

International Sales
international@pearson.com

Visit us on the Web: informit.com/ph

Library of Congress Cataloging-in-Publication Data

Fundamentals of LTE / Arunabha Ghosh . . . [et al.].

p. cm.

Includes bibliographical references and index.

ISBN-10: 0-13-703311-7 (hardcover : alk. paper)

ISBN-13: 978-0-13-703311-9 (hardcover : alk. paper) 1. Long-Term Evolution

(Telecommunications) I. Ghosh, Arunabha, 1969-

TK5103.48325.F86 2010

621.3845'6—dc22

2010021369

Copyright © 2011 Pearson Education, Inc.

All rights reserved. Printed in the United States of America. This publication is protected by copyright, and permission must be obtained from the publisher prior to any prohibited reproduction, storage in a retrieval system, or transmission in any form or by any means, electronic, mechanical, photocopying, recording, or likewise. For information regarding permissions, write to:

Pearson Education, Inc
Rights and Contracts Department
501 Boylston Street, Suite 900
Boston, MA 02116
Fax: (617) 671-3447

ISBN-13: 978-0-13-703311-9

ISBN-10: 0-13-703311-7

Text printed in the United States on recycled paper at Courier in Westford, Massachusetts.
First printing, August 2010

Engin
TK
5103.48325
.F86
2011

Contents

Foreword	xvii
Preface	xix
Acknowledgments	xxi
About the Authors	xxiii
List of Acronyms	xxv
1 Evolution of Cellular Technologies	1
1.1 Introduction	1
1.2 Evolution of Mobile Broadband	3
1.2.1 First Generation Cellular Systems	5
1.2.2 2G Digital Cellular Systems	6
1.2.3 3G Broadband Wireless Systems	10
1.2.4 Beyond 3G: HSPA+, WiMAX, and LTE	15
1.2.5 Summary of Evolution of 3GPP Standards	22
1.3 The Case for LTE/SAE	23
1.3.1 Demand Drivers for LTE	24
1.3.2 Key Requirements of LTE Design	26
1.4 Key Enabling Technologies and Features of LTE	28
1.4.1 Orthogonal Frequency Division Multiplexing (OFDM)	28
1.4.2 SC-FDE and SC-FDMA	30
1.4.3 Channel Dependent Multi-user Resource Scheduling	30
1.4.4 Multiantenna Techniques	31
1.4.5 IP-Based Flat Network Architecture	32

1.5	LTE Network Architecture	33
1.6	Spectrum Options and Migration Plans for LTE	35
1.7	Future of Mobile Broadband—Beyond LTE	39
1.8	Summary and Conclusions	41
Part I LTE Tutorials		45
2	Wireless Fundamentals	47
2.1	Communication System Building Blocks	47
2.2	The Broadband Wireless Channel: Path Loss and Shadowing	48
2.2.1	Path Loss	50
2.2.2	Shadowing	53
2.3	Cellular Systems	56
2.3.1	The Cellular Concept	57
2.3.2	Analysis of Cellular Systems	58
2.3.3	Sectoring	60
2.4	The Broadband Wireless Channel: Fading	62
2.4.1	Delay Spread and Coherence Bandwidth	66
2.4.2	Doppler Spread and Coherence Time	67
2.4.3	Angular Spread and Coherence Distance	68
2.5	Modelling Broadband Fading Channels	69
2.5.1	Statistical Channel Models	70
2.5.2	Statistical Correlation of the Received Signal	73
2.5.3	Empirical Channel Models	77
2.6	Mitigation of Narrowband Fading	82
2.6.1	The Effects of Unmitigated Fading	82
2.6.2	Spatial Diversity	84
2.6.3	Coding and Interleaving	85
2.6.4	Automatic Repeat Request (ARQ)	88
2.6.5	Adaptive Modulation and Coding (AMC)	88
2.6.6	Combining Narrowband Diversity Techniques—The Whole Is Less Than the Sum of the Parts	91
2.7	Mitigation of Broadband Fading	92
2.7.1	Spread Spectrum and RAKE Receivers	92
2.7.2	Equalization	93
2.7.3	Multicarrier Modulation: OFDM	93
2.7.4	Single-Carrier Modulation with Frequency Domain Equalization	94
2.8	Chapter Summary	94

3	Multicarrier Modulation	99
3.1	The Multicarrier Concept	100
3.1.1	An Elegant Approach to Intersymbol Interference	101
3.2	OFDM Basics	103
3.2.1	Block Transmission with Guard Intervals	103
3.2.2	Circular Convolution and the DFT	104
3.2.3	The Cyclic Prefix	105
3.2.4	Frequency Equalization	107
3.2.5	An OFDM Block Diagram	108
3.3	OFDM in LTE	109
3.4	Timing and Frequency Synchronization	110
3.4.1	Timing Synchronization	111
3.4.2	Frequency Synchronization	114
3.5	The Peak-to-Average Ratio	116
3.5.1	The PAR Problem	116
3.5.2	Quantifying the PAR	118
3.5.3	Clipping and Other PAR Reduction Techniques	121
3.5.4	LTE's Approach to PAR in the Uplink	123
3.6	Single-Carrier Frequency Domain Equalization (SC-FDE)	124
3.6.1	SC-FDE System Description	124
3.6.2	SC-FDE Performance vs. OFDM	126
3.6.3	Design Considerations for SC-FDE and OFDM	126
3.7	The Computational Complexity Advantage of OFDM and SC-FDE	127
3.8	Chapter Summary	130
4	Frequency Domain Multiple Access: OFDMA and SC-FDMA	133
4.1	Multiple Access for OFDM Systems	134
4.1.1	Multiple Access Overview	134
4.1.2	Random Access vs. Multiple Access	135
4.1.3	Frequency Division Multiple Access (OFDM-FDMA)	136
4.1.4	Time Division Multiple Access (OFDM-TDMA)	137
4.1.5	Code Division Multiple Access (OFDM-CDMA or MC-CDMA)	137
4.2	Orthogonal Frequency Division Multiple Access (OFDMA)	138
4.2.1	OFDMA: How It Works	139
4.2.2	OFDMA Advantages and Disadvantages	142
4.3	Single-Carrier Frequency Division Multiple Access (SC-FDMA)	142

4.3.1	SC-FDMA: How It Works	142
4.3.2	SC-FDMA Advantages and Disadvantages	143
4.4	Multiuser Diversity and Opportunistic Scheduling	144
4.4.1	Multiuser Diversity	144
4.4.2	Opportunistic Scheduling Approaches for OFDMA	146
4.4.3	Maximum Sum Rate Algorithm	147
4.4.4	Maximum Fairness Algorithm	148
4.4.5	Proportional Rate Constraints Algorithm	148
4.4.6	Proportional Fairness Scheduling	149
4.4.7	Performance Comparison	150
4.5	OFDMA and SC-FDMA in LTE	152
4.5.1	The LTE Time-Frequency Grid	153
4.5.2	Allocation Notification and Uplink Feedback	154
4.5.3	Power Control	154
4.6	OFDMA System Design Considerations	155
4.6.1	Resource Allocation in Cellular Systems	156
4.6.2	Fractional Frequency Reuse in Cellular Systems	157
4.6.3	Multiuser Diversity vs. Frequency and Spatial Diversity	159
4.7	Chapter Summary	160
5	Multiple Antenna Transmission and Reception	167
5.1	Spatial Diversity Overview	168
5.1.1	Array Gain	168
5.1.2	Diversity Gain	169
5.1.3	Increasing the Data Rate with Spatial Diversity	170
5.1.4	Increased Coverage or Reduced Transmit Power	171
5.2	Receive Diversity	171
5.2.1	Selection Combining	171
5.2.2	Maximal Ratio Combining	173
5.3	Transmit Diversity	174
5.3.1	Open-Loop Transmit Diversity: 2×1 Space-Frequency Block Coding	175
5.3.2	Open-Loop Transmit Diversity with More Antennas	177
5.3.3	Transmit Diversity vs. Receive Diversity	180
5.3.4	Closed-Loop Transmit Diversity	181
5.4	Interference Cancellation Suppression and Signal Enhancement	186

5.4.1	DOA-Based Beamsteering	187
5.4.2	Linear Interference Suppression: Complete Knowledge of Interference Channels	189
5.4.3	Linear Interference Suppression: Statistical Knowledge of Interference Channels	190
5.5	Spatial Multiplexing	192
5.5.1	An Introduction to Spatial Multiplexing	193
5.5.2	Open-Loop MIMO: Spatial Multiplexing Without Channel Feedback	194
5.5.3	Closed-Loop MIMO	198
5.6	How to Choose Between Diversity, Interference Suppression, and Spatial Multiplexing	200
5.7	Channel Estimation and Feedback for MIMO and MIMO-OFDM	202
5.7.1	Channel Estimation	202
5.7.2	Channel Feedback	206
5.8	Practical Issues That Limit MIMO Gains	208
5.8.1	Multipath	208
5.8.2	Uncorrelated Antennas	208
5.8.3	Interference-Limited MIMO Systems	209
5.9	Multiuser and Networked MIMO Systems	209
5.9.1	Multiuser MIMO	210
5.9.2	Networked MIMO	212
5.10	An Overview of MIMO in LTE	213
5.10.1	An Overview of MIMO in the LTE Downlink	213
5.10.2	An Overview of MIMO in the LTE Uplink	214
5.11	Chapter Summary	215
Part II The LTE Standard		225
6	Overview and Channel Structure of LTE	227
6.1	Introduction to LTE	228
6.1.1	Design Principles	229
6.1.2	Network Architecture	231
6.1.3	Radio Interface Protocols	232
6.2	Hierarchical Channel Structure of LTE	234
6.2.1	Logical Channels: What to Transmit	235
6.2.2	Transport Channels: How to Transmit	236

6.2.3	Physical Channels: Actual Transmission	239
6.2.4	Channel Mapping	240
6.3	Downlink OFDMA Radio Resources	241
6.3.1	Frame Structure	242
6.3.2	Physical Resource Blocks for OFDMA	246
6.3.3	Resource Allocation	248
6.3.4	Supported MIMO Modes	251
6.4	Uplink SC-FDMA Radio Resources	251
6.4.1	Frame Structure	252
6.4.2	Physical Resource Blocks for SC-FDMA	252
6.4.3	Resource Allocation	254
6.4.4	Supported MIMO Modes	254
6.5	Summary and Conclusions	255
7	Downlink Transport Channel Processing	257
7.1	Downlink Transport Channel Processing Overview	257
7.1.1	Channel Coding Processing	258
7.1.2	Modulation Processing	263
7.2	Downlink Shared Channels	268
7.2.1	Channel Encoding and Modulation	269
7.2.2	Multiantenna Transmission	270
7.3	Downlink Control Channels	276
7.3.1	Downlink Control Information (DCI) Formats	277
7.3.2	Channel Encoding and Modulation	279
7.3.3	Multiantenna Transmission	282
7.4	Broadcast Channels	283
7.5	Multicast Channels	284
7.6	Downlink Physical Signals	285
7.6.1	Downlink Reference Signals	285
7.6.2	Synchronization Signals	289
7.7	H-ARQ in the Downlink	290
7.8	Summary and Conclusions	293
8	Uplink Transport Channel Processing	295
8.1	Uplink Transport Channel Processing Overview	296
8.1.1	Channel Coding Processing	296
8.1.2	Modulation Processing	297

8.2	Uplink Shared Channels	298
8.2.1	Channel Encoding and Modulation	299
8.2.2	Frequency Hopping	299
8.2.3	Multiantenna Transmission	300
8.3	Uplink Control Information	301
8.3.1	Channel Coding for Uplink Control Information	302
8.3.2	Modulation of PUCCH	306
8.3.3	Resource Mapping	308
8.4	Uplink Reference Signals	309
8.4.1	Reference Signal Sequence	310
8.4.2	Resource Mapping of Demodulation Reference Signals	310
8.4.3	Resource Mapping of Sounding Reference Signals	311
8.5	Random Access Channels	313
8.6	H-ARQ in the Uplink	315
8.6.1	The FDD Mode	315
8.6.2	The TDD Mode	315
8.7	Summary and Conclusions	317
9	Physical Layer Procedures and Scheduling	319
9.1	Hybrid-ARQ Feedback	319
9.1.1	H-ARQ Feedback for Downlink (DL) Transmission	320
9.1.2	H-ARQ Indicator for Uplink (UL) Transmission	321
9.2	Channel Quality Indicator (CQI) Feedback	322
9.2.1	A Primer on CQI Estimation	323
9.2.2	CQI Feedback Modes	325
9.3	Precoder for Closed-Loop MIMO Operations	333
9.3.1	Precoder Estimation for Multicarrier Systems	333
9.3.2	Precoding Matrix Index (PMI) and Rank Indication (RI) Feedback	334
9.4	Uplink Channel Sounding	337
9.5	Buffer Status Reporting in Uplink	337
9.6	Scheduling and Resource Allocation	339
9.6.1	Signaling for Scheduling in Downlink and Uplink	340
9.6.2	Multuser MIMO Signaling	344
9.7	Semi-persistent Scheduling for VoIP	344
9.7.1	Motivation for Semi-persistent Scheduling	344
9.7.2	Changes in the Signaling Structure	345

9.8	Cell Search	346
9.9	Random Access Procedures	348
9.10	Power Control in Uplink	350
9.11	Summary and Conclusions	352
10	Data Flow, Radio Resource Management, and Mobility Management	355
10.1	PDCP Overview	359
10.1.1	Header Compression	361
10.1.2	Integrity and Ciphering	361
10.2	MAC/RLC Overview	363
10.2.1	Data Transfer Modes	363
10.2.2	Purpose of MAC and RLC Layers	364
10.2.3	PDU Headers and Formats	365
10.2.4	ARQ Procedures	368
10.3	RRC Overview	369
10.3.1	RRC States	369
10.3.2	RRC Functions	370
10.4	Mobility Management	371
10.4.1	S1 Mobility	371
10.4.2	X2 Mobility	373
10.4.3	RAN Procedures for Mobility	374
10.4.4	Paging	376
10.5	Inter-cell Interference Coordination	377
10.5.1	Downlink	377
10.5.2	Uplink	379
10.6	Summary and Conclusions	380
Index		383

Attachment B-1

The logo for Prentice Hall, featuring a red grid of dots to the left of the text "PRENTICE HALL" in white, with "PRENTICE" on the top line and "HALL" on the bottom line.

PRENTICE
HALL

Fundamentals of **LTE**

Arunabha Ghosh • Jun Zhang
Jeffrey G. Andrews • Rias Muhamed

Foreword by Rajiv Laroia

Fundamentals of LTE

ARUNABHA GHOSH
JUN ZHANG
JEFFREY G. ANDREWS
RIAS MUHAMED



Upper Saddle River, NJ • Boston • Indianapolis • San Francisco
New York • Toronto • Montreal • London • Munich • Paris • Madrid
Capetown • Sydney • Tokyo • Singapore • Mexico City

Many of the designations used by manufacturers and sellers to distinguish their products are claimed as trademarks. Where those designations appear in this book, and the publisher was aware of a trademark claim, the designations have been printed with initial capital letters or in all capitals.

The authors and publisher have taken care in the preparation of this book, but make no expressed or implied warranty of any kind and assume no responsibility for errors or omissions. No liability is assumed for incidental or consequential damages in connection with or arising out of the use of the information or programs contained herein.

Credits and permissions appear on pages 417 and 418.

The publisher offers excellent discounts on this book when ordered in quantity for bulk purchases or special sales, which may include electronic versions and/or custom covers and content particular to your business, training goals, marketing focus, and branding interests. For more information, please contact:

☰ Fundamentals of LTE

corpsales@pearsontechgroup.com

For sales outside the United States please contact:

International Sales

international@pearson.com

Visit us on the Web: informit.com/ph

Library of Congress Cataloging-in-Publication Data

Fundamentals of LTE / Arunabha Ghosh ... [et al.].

p. cm.

Includes bibliographical references and index.

ISBN-10: 0-13-703311-7 (hardcover : alk. paper)

ISBN-13: 978-0-13-703311-9 (hardcover : alk. paper) 1. Long-Term Evolution

(Telecommunications) I. Ghosh, Arunabha, 1969–

TK5103.48325.F86 2010

621.3845'6--dc22

2010021369

Copyright © 2011 Pearson Education, Inc.

All rights reserved. Printed in the United States of America. This publication is protected by copyright, and permission must be obtained from the publisher prior to any prohibited reproduction, storage in a retrieval system, or transmission in any form or by any means, electronic, mechanical, photocopying, recording, or likewise. For information regarding permissions, write to:

- . . . -

Contents

Foreword

Preface

Acknowledgments

LTE

☰ Fundamentals of LTE

List of Acronyms

1 Evolution of Cellular Technologies

1.1 Introduction

1.2 Evolution of Mobile Broadband

1.2.1 First Generation Cellular Systems

1.2.2 2G Digital Cellular Systems

1.2.3 3G Broadband Wireless Systems

1.2.4 Beyond 3G: HSPA+, WiMAX, and LTE

1.2.5 Summary of Evolution of 3GPP Standards

1.3 The Case for LTE/SAE

1.3.1 Demand Drivers for LTE

1.3.2 Key Requirements of LTE Design

1.4 Key Enabling Technologies and Features of LTE

1.4.1 Orthogonal Frequency Division Multiplexing (OFDM)

1.4.2 SC-FDE and SC-FDMA

1.4.3 Channel Dependent Multi-user Resource Scheduling

1.4.4 Multiantenna Techniques

LTE

☰ Fundamentals of LTE

1.5 LTE Network Architecture

1.6 Spectrum Options and Migration Plans for LTE

1.7 Future of Mobile Broadband—Beyond LTE

1.8 Summary and Conclusions

Part I LTE Tutorials

2 Wireless Fundamentals

2.1 Communication System Building Blocks

2.2 The Broadband Wireless Channel: Path Loss and Shadowing

2.2.1 Path Loss

2.2.2 Shadowing

2.3 Cellular Systems

2.3.1 The Cellular Concept

2.3.2 Analysis of Cellular Systems

2.3.3 Sectoring

2.4 The Broadband Wireless Channel: Fading

2.4.1 Delay Spread and Coherence Bandwidth

2.4.2 Doppler Spread and Coherence Time

2.4.3 Angular Spread and Coherence Distance

[2.5.3 Empirical Channel Models](#)

[2.6 Mitigation of Narrowband Fading](#)

[2.6.1 The Effects of Unmitigated Fading](#)

[2.6.4 Automatic Repeat Request \(ARQ\)](#)

[2.6.5 Adaptive Modulation and Coding \(AMC\)](#)

[2.6.6 Combining Narrowband Diversity Techniques—The Whole Is Less Than the Sum of the Parts](#)

[2.7 Mitigation of Broadband Fading](#)

[2.7.1 Spread Spectrum and RAKE Receivers](#)

[2.7.2 Equalization](#)

[2.7.3 Multicarrier Modulation: OFDM](#)

[2.7.4 Single-Carrier Modulation with Frequency Domain Equalization](#)

[2.8 Chapter Summary](#)

[3 Multicarrier Modulation](#)

[3.1 The Multicarrier Concept](#)

[3.1.1 An Elegant Approach to Intersymbol Interference](#)

[3.2 OFDM Basics](#)

[3.2.1 Block Transmission with Guard Intervals](#)

[3.2.2 Circular Convolution and the DFT](#)

[3.2.3 The Cyclic Prefix](#)

[3.2.4 Frequency Equalization](#)

[3.2.5 An OFDM Block Diagram](#)

[3.3 OFDM in LTE](#)

[3.4 Timing and Frequency Synchronization](#)

[3.4.1 Timing Synchronization](#)

[3.4.2 Frequency Synchronization](#)

[3.5 The Peak-to-Average Ratio](#)

LTE

☰ Fundamentals of LTE

[3.5.2 Quantifying the PAR](#)

[3.5.3 Clipping and Other PAR Reduction Techniques](#)

[3.5.4 LTE's Approach to PAR in the Uplink](#)

[3.6 Single-Carrier Frequency Domain Equalization \(SC-FDE\)](#)

[3.6.1 SC-FDE System Description](#)

[3.6.2 SC-FDE Performance vs. OFDM](#)

[3.6.3 Design Considerations for SC-FDE and OFDM](#)

[3.7 The Computational Complexity Advantage of OFDM and SC-FDE](#)

[3.8 Chapter Summary](#)

[4 Frequency Domain Multiple Access: OFDMA and SC-FDMA](#)

[4.1 Multiple Access for OFDM Systems](#)

[4.1.1 Multiple Access Overview](#)

[4.1.2 Random Access vs. Multiple Access](#)

[4.1.3 Frequency Division Multiple Access \(OFDM-FDMA\)](#)

[4.1.4 Time Division Multiple Access \(OFDM-TDMA\)](#)

[4.1.5 Code Division Multiple Access \(OFDM-CDMA or MC-CDMA\)](#)

[4.2 Orthogonal Frequency Division Multiple Access \(OFDMA\)](#)

[4.2.1 OFDMA: How It Works](#)

[4.2.2 OFDMA Advantages and Disadvantages](#)

LTE

☰ Fundamentals of LTE

[4.3.2 SC-FDMA Advantages and Disadvantages](#)

[4.4 Multiuser Diversity and Opportunistic Scheduling](#)

[4.4.1 Multiuser Diversity](#)

[4.4.2 Opportunistic Scheduling Approaches for OFDMA](#)

[4.4.3 Maximum Sum Rate Algorithm](#)

[4.4.4 Maximum Fairness Algorithm](#)

[4.4.5 Proportional Rate Constraints Algorithm](#)

[4.4.6 Proportional Fairness Scheduling](#)

[4.4.7 Performance Comparison](#)

[4.5 OFDMA and SC-FDMA in LTE](#)

[4.5.1 The LTE Time-Frequency Grid](#)

[4.5.2 Allocation Notification and Uplink Feedback](#)

[4.5.3 Power Control](#)

[4.6 OFDMA System Design Considerations](#)

[4.6.1 Resource Allocation in Cellular Systems](#)

[4.6.2 Fractional Frequency Reuse in Cellular Systems](#)

[4.6.3 Multiuser Diversity vs. Frequency and Spatial Diversity](#)

[4.7 Chapter Summary](#)

5 Multiple Antenna Transmission and Reception

[5.1 Spatial Diversity Overview](#)

[5.1.1 Array Gain](#)

[5.1.2 Diversity Gain](#)

[5.1.3 Increasing the Data Rate with Spatial Diversity](#)

[5.1.4 Increased Coverage or Reduced Transmit Power](#)

[5.2 Receive Diversity](#)

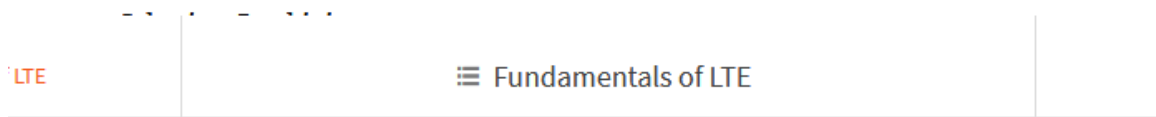

[5.3 Transmit Diversity](#)

[5.3.1 Open-Loop Transmit Diversity: \$2 \times 1\$ Space-Frequency Block Coding](#)

[5.3.2 Open-Loop Transmit Diversity with More Antennas](#)

[5.3.3 Transmit Diversity vs. Receive Diversity](#)

[5.3.4 Closed-Loop Transmit Diversity](#)

[5.4 Interference Cancellation Suppression and Signal Enhancement](#)

[5.4.1 DOA-Based Beamsteering](#)

[5.4.2 Linear Interference Suppression: Complete Knowledge of Interference Channels](#)

[5.4.3 Linear Interference Suppression: Statistical Knowledge of Interference Channels](#)

[5.5 Spatial Multiplexing](#)

[5.5.1 An Introduction to Spatial Multiplexing](#)

[5.5.2 Open-Loop MIMO: Spatial Multiplexing Without Channel Feedback](#)

TE

☰ Fundamentals of LTE

[5.6 How to Choose Between Diversity, Interference Suppression, and Spatial Multiplexing](#)

[5.7 Channel Estimation and Feedback for MIMO and MIMO-OFDM](#)

[5.7.1 Channel Estimation](#)

[5.7.2 Channel Feedback](#)

[5.8 Practical Issues That Limit MIMO Gains](#)

[5.8.1 Multipath](#)

[5.8.2 Uncorrelated Antennas](#)

[5.8.3 Interference-Limited MIMO Systems](#)

[5.9 Multiuser and Networked MIMO Systems](#)

[5.9.1 Multiuser MIMO](#)

[5.9.2 Networked MIMO](#)

[5.10 An Overview of MIMO in LTE](#)

[5.10.1 An Overview of MIMO in the LTE Downlink](#)

[5.10.2 An Overview of MIMO in the LTE Uplink](#)

[5.11 Chapter Summary](#)

[Part II The LTE Standard](#)

6 Overview and Channel Structure of LTE

6.1 Introduction to LTE

6.1.1 Design Principles

6.1.2 Network Architecture

6.1.3 Radio Interface Protocols

6.2 Hierarchical Channel Structure of LTE

6.2.1 Logical Channels: What to Transmit

6.2.2 Transport Channels: How to Transmit

6.2.3 Physical Channels: Actual Transmission

6.2.4 Channel Mapping

TE

☰ Fundamentals of LTE

6.3.1 Frame Structure

6.3.2 Physical Resource Blocks for OFDMA

6.3.3 Resource Allocation

6.3.4 Supported MIMO Modes

6.4 Uplink SC-FDMA Radio Resources

6.4.1 Frame Structure

6.4.2 Physical Resource Blocks for SC-FDMA

6.4.3 Resource Allocation

6.4.4 Supported MIMO Modes

6.5 Summary and Conclusions

7 Downlink Transport Channel Processing

[7.1 Downlink Transport Channel Processing Overview](#)

[7.1.1 Channel Coding Processing](#)

[7.1.2 Modulation Processing](#)

[7.2 Downlink Shared Channels](#)

[7.2.1 Channel Encoding and Modulation](#)

[7.2.2 Multiantenna Transmission](#)

[7.3 Downlink Control Channels](#)

[7.3.1 Downlink Control Information \(DCI\) Formats](#)

[7.3.2 Channel Encoding and Modulation](#)

[7.3.3 Multiantenna Transmission](#)

LTE

☰ Fundamentals of LTE

[7.5 Multicast Channels](#)

[7.6 Downlink Physical Signals](#)

[7.6.1 Downlink Reference Signals](#)

[7.6.2 Synchronization Signals](#)

[7.7 H-ARQ in the Downlink](#)

[7.8 Summary and Conclusions](#)

[8 Uplink Transport Channel Processing](#)

[8.1 Uplink Transport Channel Processing Overview](#)

[8.1.1 Channel Coding Processing](#)

[8.1.2 Modulation Processing](#)

[8.2 Uplink Shared Channels](#)

[8.2.1 Channel Encoding and Modulation](#)

[8.2.2 Frequency Hopping](#)

[8.2.3 Multiantenna Transmission](#)

[8.3 Uplink Control Information](#)

[8.3.1 Channel Coding for Uplink Control Information](#)

[8.3.2 Modulation of PUCCH](#)

[8.3.3 Resource Mapping](#)

[8.4 Uplink Reference Signals](#)

[8.4.1 Reference Signal Sequence](#)

[8.4.2 Resource Mapping of Demodulation Reference Signals](#)

LTE

☰ Fundamentals of LTE

[8.5 Random Access Channels](#)

[8.6 H-ARQ in the Uplink](#)

[8.6.1 The FDD Mode](#)

[8.6.2 The TDD Mode](#)

[8.7 Summary and Conclusions](#)

[9 Physical Layer Procedures and Scheduling](#)

[9.1 Hybrid-ARQ Feedback](#)

[9.1.1 H-ARQ Feedback for Downlink \(DL\) Transmission](#)

[9.1.2 H-ARQ Indicator for Uplink \(UL\) Transmission](#)

[9.2 Channel Quality Indicator \(CQI\) Feedback](#)

[9.2.1 A Primer on CQI Estimation](#)

[9.2.2 CQI Feedback Modes](#)

[9.3 Precoder for Closed-Loop MIMO Operations](#)

[9.3.1 Precoder Estimation for Multicarrier Systems](#)

[9.3.2 Precoding Matrix Index \(PMI\) and Rank Indication \(RI\) Feedback](#)

[9.4 Uplink Channel Sounding](#)

[9.5 Buffer Status Reporting in Uplink](#)

[9.6 Scheduling and Resource Allocation](#)

[9.6.1 Signaling for Scheduling in Downlink and Uplink](#)

[9.6.2 Multiuser MIMO Signaling](#)

[9.7 Semi-persistent Scheduling for VoIP](#)

f LTE

☰ Fundamentals of LTE

[9.8 Cell Search](#)

[9.9 Random Access Procedures](#)

[9.10 Power Control in Uplink](#)

[9.11 Summary and Conclusions](#)

[10 Data Flow, Radio Resource Management, and Mobility Management](#)

[10.1 PDCP Overview](#)

[10.1.1 Header Compression](#)

[10.1.2 Integrity and Ciphering](#)

[10.2 MAC/RLC Overview](#)

[10.2.1 Data Transfer Modes](#)

[10.2.2 Purpose of MAC and RLC Layers](#)

[10.2.3 PDU Headers and Formats](#)

[10.2.4 ARQ Procedures](#)

[10.3 RRC Overview](#)

LTE

☰ Fundamentals of LTE

[10.3.2 RRC Functions](#)

[10.4 Mobility Management](#)

[10.4.1 S1 Mobility](#)

[10.4.2 X2 Mobility](#)

[10.4.3 RAN Procedures for Mobility](#)

[10.4.4 Paging](#)

[10.5 Inter-cell Interference Coordination](#)

[10.5.1 Downlink](#)

[10.5.2 Uplink](#)

[10.6 Summary and Conclusions](#)

[**Index**](#)

Attachment C-1

Library

Search

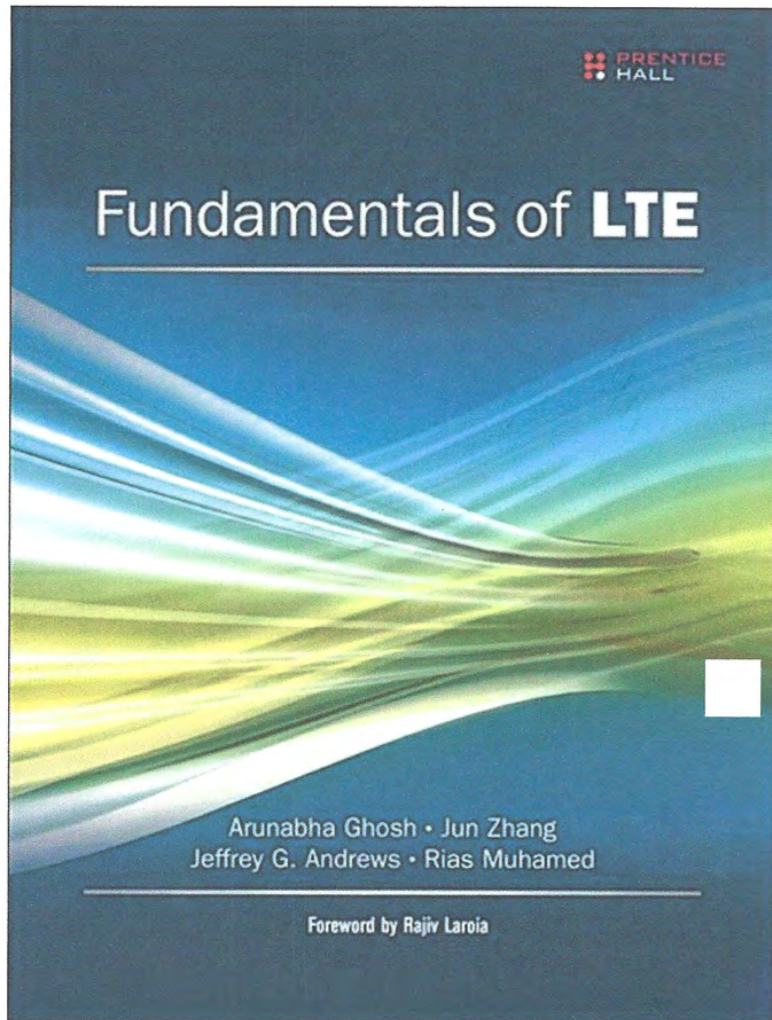

0% · Location 1 of 10892

Library

Search 

Fundamentals of LTE

Arunabha Ghosh
Jun Zhang
Jeffrey G. Andrews
Rias Muhamed



Upper Saddle River, NJ • Boston • Indianapolis • San Francisco
New York • Toronto • Montreal • London • Munich • Paris • Madrid
Capetown • Sydney • Tokyo • Singapore • Mexico City

Library

Search

Many of the designations used by manufacturers and sellers to distinguish their products are claimed as trademarks. Where those designations appear in this book, and the publisher was aware of a trademark claim, the designations have been printed with initial capital letters or in all capitals.

The authors and publisher have taken care in the preparation of this book, but make no expressed or implied warranty of any kind and assume no responsibility for errors or omissions. No liability is assumed for incidental or consequential damages in connection with or arising out of the use of the information or programs contained herein.

Credits and permissions appear on pages [417](#) and [418](#).

The publisher offers excellent discounts on this book when ordered in quantity for bulk purchases or special sales, which may include electronic versions and/or custom covers and content particular to your business, training goals, marketing focus, and branding interests. For more information, please contact:

U.S. Corporate and Government Sales
(800) 382-3419
corpsales@pearsontechgroup.com

For sales outside the United States please contact:

International Sales
international@pearson.com

Visit us on the Web: informit.com/ph

Library of Congress Cataloging-in-Publication Data

Fundamentals of LTE / Arunabha Ghosh ... [et al.].
p. cm.

Library

Search 

Includes bibliographical references and index.
 ISBN-10: 0-13-703311-7 (hardcover : alk. paper)
 ISBN-13: 978-0-13-703311-9 (hardcover : alk. paper) 1. Long-Term Evolution
 (Telecommunications) I. Ghosh, Arunabha, 1969–
 TK5103.48325.F86 2010
 621.3845'6---dc22 2010021369

Copyright © 2011 Pearson Education, Inc.

All rights reserved. Printed in the United States of America. This publication is protected by copyright, and permission must be obtained from the publisher prior to any prohibited reproduction, storage in a retrieval system, or transmission in any form or by any means, electronic, mechanical, photocopying, recording, or likewise. For information regarding permissions, write to:

Pearson Education, Inc
 Rights and Contracts Department
 501 Boylston Street, Suite 900
 Boston, MA 02116
 Fax: (617) 671-3447

ISBN-13: 978-0-13-703311-9
 ISBN-10: 0-13-703311-7

Text printed in the United States on recycled paper at Courier in Westford, Massachusetts.

First printing, August 2010

Library

Search



Contents

[Foreword](#)[Preface](#)[Acknowledgments](#)[About the Authors](#)[List of Acronyms](#)

[1 Evolution of Cellular Technologies](#)

[1.1 Introduction](#)[1.2 Evolution of Mobile Broadband](#)[1.2.1 First Generation Cellular Systems](#)[1.2.2 2G Digital Cellular Systems](#)[1.2.3 3G Broadband Wireless Systems](#)[1.2.4 Beyond 3G: HSPA+, WiMAX, and LTE](#)[1.2.5 Summary of Evolution of 3GPP Standards](#)[1.3 The Case for LTE/SAE](#)[1.3.1 Demand Drivers for LTE](#)[1.3.2 Key Requirements of LTE Design](#)[1.4 Key Enabling Technologies and Features of LTE](#)[1.4.1 Orthogonal Frequency Division Multiplexing \(OFDM\)](#)[1.4.2 SC-FDE and SC-FDMA](#)

Library

Search 

- [1.4.3 Channel Dependent Multi-user Resource Scheduling](#)
- [1.4.4 Multiantenna Techniques](#)
- [1.4.5 IP-Based Flat Network Architecture](#)
- [1.5 LTE Network Architecture](#)
- [1.6 Spectrum Options and Migration Plans for LTE](#)
- [1.7 Future of Mobile Broadband—Beyond LTE](#)
- [1.8 Summary and Conclusions](#)

Part I LTE Tutorials

2 Wireless Fundamentals

- [2.1 Communication System Building Blocks](#)
- [2.2 The Broadband Wireless Channel: Path Loss and Shadowing](#)
 - [2.2.1 Path Loss](#)
 - [2.2.2 Shadowing](#)
- [2.3 Cellular Systems](#)
 - [2.3.1 The Cellular Concept](#)
 - [2.3.2 Analysis of Cellular Systems](#)
 - [2.3.3 Sectoring](#)
- [2.4 The Broadband Wireless Channel: Fading](#)
 - [2.4.1 Delay Spread and Coherence Bandwidth](#)
 - [2.4.2 Doppler Spread and Coherence Time](#)
 - [2.4.3 Angular Spread and Coherence Distance](#)

Library

Search

[2.5.3 Empirical Channel Models](#)[2.6 Mitigation of Narrowband Fading](#)[2.6.1 The Effects of Unmitigated Fading](#)[2.6.2 Spatial Diversity](#)[2.6.3 Coding and Interleaving](#)[2.6.4 Automatic Repeat Request \(ARQ\)](#)[2.6.5 Adaptive Modulation and Coding \(AMC\)](#)[2.6.6 Combining Narrowband Diversity Techniques—The Whole Is Less Than the Sum of the Parts](#)[2.7 Mitigation of Broadband Fading](#)[2.7.1 Spread Spectrum and RAKE Receivers](#)[2.7.2 Equalization](#)[2.7.3 Multicarrier Modulation: OFDM](#)[2.7.4 Single-Carrier Modulation with Frequency Domain Equalization](#)[2.8 Chapter Summary](#)**[3 Multicarrier Modulation](#)**[3.1 The Multicarrier Concept](#)[3.1.1 An Elegant Approach to Intersymbol Interference](#)[3.2 OFDM Basics](#)[3.2.1 Block Transmission with Guard Intervals](#)[3.2.2 Circular Convolution and the DFT](#)[3.2.3 The Cyclic Prefix](#)

Library

Search



- [3.2.4 Frequency Equalization](#)
 - [3.2.5 An OFDM Block Diagram](#)
 - [3.3 OFDM in LTE](#)
 - [3.4 Timing and Frequency Synchronization](#)
 - [3.4.1 Timing Synchronization](#)
 - [3.4.2 Frequency Synchronization](#)
 - [3.5 The Peak-to-Average Ratio](#)
 - [3.5.1 The PAR Problem](#)
 - [3.5.2 Quantifying the PAR](#)
 - [3.5.3 Clipping and Other PAR Reduction Techniques](#)
 - [3.5.4 LTE's Approach to PAR in the Uplink](#)
 - [3.6 Single-Carrier Frequency Domain Equalization \(SC-FDE\)](#)
 - [3.6.1 SC-FDE System Description](#)
 - [3.6.2 SC-FDE Performance vs. OFDM](#)
 - [3.6.3 Design Considerations for SC-FDE and OFDM](#)
 - [3.7 The Computational Complexity Advantage of OFDM and SC-FDE](#)
 - [3.8 Chapter Summary](#)
- [4 Frequency Domain Multiple Access: OFDMA and SC-FDMA](#)**
- [4.1 Multiple Access for OFDM Systems](#)
 - [4.1.1 Multiple Access Overview](#)
 - [4.1.2 Random Access vs. Multiple Access](#)
 - [4.1.3 Frequency Division Multiple Access \(OFDM-FDMA\)](#)

Library

Search



- [4.1.4 Time Division Multiple Access \(OFDM-TDMA\)](#)
- [4.1.5 Code Division Multiple Access \(OFDM-CDMA or MC-CDMA\)](#)
- [4.2 Orthogonal Frequency Division Multiple Access \(OFDMA\)](#)
 - [4.2.1 OFDMA: How It Works](#)
 - [4.2.2 OFDMA Advantages and Disadvantages](#)
- [4.3 Single-Carrier Frequency Division Multiple Access \(SC-FDMA\)](#)
 - [4.3.1 SC-FDMA: How It Works](#)
 - [4.3.2 SC-FDMA Advantages and Disadvantages](#)
- [4.4 Multiuser Diversity and Opportunistic Scheduling](#)
 - [4.4.1 Multiuser Diversity](#)
 - [4.4.2 Opportunistic Scheduling Approaches for OFDMA](#)
 - [4.4.3 Maximum Sum Rate Algorithm](#)
 - [4.4.4 Maximum Fairness Algorithm](#)
 - [4.4.5 Proportional Rate Constraints Algorithm](#)
 - [4.4.6 Proportional Fairness Scheduling](#)
 - [4.4.7 Performance Comparison](#)
- [4.5 OFDMA and SC-FDMA in LTE](#)
 - [4.5.1 The LTE Time-Frequency Grid](#)
 - [4.5.2 Allocation Notification and Uplink Feedback](#)
 - [4.5.3 Power Control](#)
- [4.6 OFDMA System Design Considerations](#)
 - [4.6.1 Resource Allocation in Cellular Systems](#)

Library

Search

[4.6.2 Fractional Frequency Reuse in Cellular Systems](#)[4.6.3 Multiuser Diversity vs. Frequency and Spatial Diversity](#)[4.7 Chapter Summary](#)

[5 Multiple Antenna Transmission and Reception](#)

[5.1 Spatial Diversity Overview](#)[5.1.1 Array Gain](#)[5.1.2 Diversity Gain](#)[5.1.3 Increasing the Data Rate with Spatial Diversity](#)[5.1.4 Increased Coverage or Reduced Transmit Power](#)[5.2 Receive Diversity](#)[5.2.1 Selection Combining](#)[5.2.2 Maximal Ratio Combining](#)[5.3 Transmit Diversity](#)[5.3.1 Open-Loop Transmit Diversity: \$2 \times 1\$ Space-Frequency Block Coding](#)[5.3.2 Open-Loop Transmit Diversity with More Antennas](#)[5.3.3 Transmit Diversity vs. Receive Diversity](#)[5.3.4 Closed-Loop Transmit Diversity](#)[5.4 Interference Cancellation Suppression and Signal Enhancement](#)[5.4.1 DOA-Based Beamsteering](#)[5.4.2 Linear Interference Suppression: Complete Knowledge of Interference Channels](#)[5.4.3 Linear Interference Suppression: Statistical Knowledge of Interference](#)

FUNDAMENTALS OF LTE (PRENTICE HALL COMMUNICATIONS...

[Channels](#)[5.5 Spatial Multiplexing](#)[5.5.1 An Introduction to Spatial Multiplexing](#)[5.5.2 Open-Loop MIMO: Spatial Multiplexing Without Channel Feedback](#)[5.5.3 Closed-Loop MIMO](#)[5.6 How to Choose Between Diversity, Interference Suppression, and Spatial Multiplexing](#)[5.7 Channel Estimation and Feedback for MIMO and MIMO-OFDM](#)[5.7.1 Channel Estimation](#)[5.7.2 Channel Feedback](#)[5.8 Practical Issues That Limit MIMO Gains](#)[5.8.1 Multipath](#)[5.8.2 Uncorrelated Antennas](#)[5.8.3 Interference-Limited MIMO Systems](#)[5.9 Multiuser and Networked MIMO Systems](#)[5.9.1 Multiuser MIMO](#)[5.9.2 Networked MIMO](#)[5.10 An Overview of MIMO in LTE](#)[5.10.1 An Overview of MIMO in the LTE Downlink](#)[5.10.2 An Overview of MIMO in the LTE Uplink](#)[5.11 Chapter Summary](#)**[Part II The LTE Standard](#)**

FUNDAMENTALS OF LTE (PRENTICE HALL COMMUNICATIONS...

6 Overview and Channel Structure of LTE

6.1 Introduction to LTE

6.1.1 Design Principles

6.1.2 Network Architecture

6.1.3 Radio Interface Protocols

6.2 Hierarchical Channel Structure of LTE

6.2.1 Logical Channels: What to Transmit

6.2.2 Transport Channels: How to Transmit

6.2.3 Physical Channels: Actual Transmission

6.2.4 Channel Mapping

6.3 Downlink OFDMA Radio Resources

6.3.1 Frame Structure

6.3.2 Physical Resource Blocks for OFDMA

6.3.3 Resource Allocation

6.3.4 Supported MIMO Modes

6.4 Uplink SC-FDMA Radio Resources

6.4.1 Frame Structure

6.4.2 Physical Resource Blocks for SC-FDMA

6.4.3 Resource Allocation

6.4.4 Supported MIMO Modes

6.5 Summary and Conclusions

7 Downlink Transport Channel Processing

Library

Search 

[7.1 Downlink Transport Channel Processing Overview](#)

[7.1.1 Channel Coding Processing](#)

[7.1.2 Modulation Processing](#)

[7.2 Downlink Shared Channels](#)

[7.2.1 Channel Encoding and Modulation](#)

[7.2.2 Multiantenna Transmission](#)

[7.3 Downlink Control Channels](#)

[7.3.1 Downlink Control Information \(DCI\) Formats](#)

[7.3.2 Channel Encoding and Modulation](#)

[7.3.3 Multiantenna Transmission](#)

[7.4 Broadcast Channels](#)

[7.5 Multicast Channels](#)

[7.6 Downlink Physical Signals](#)

[7.6.1 Downlink Reference Signals](#)

[7.6.2 Synchronization Signals](#)

[7.7 H-ARQ in the Downlink](#)

[7.8 Summary and Conclusions](#)

[8 Uplink Transport Channel Processing](#)

[8.1 Uplink Transport Channel Processing Overview](#)

[8.1.1 Channel Coding Processing](#)

[8.1.2 Modulation Processing](#)

[8.2 Uplink Shared Channels](#)

Library

Search

[8.2.1 Channel Encoding and Modulation](#)[8.2.2 Frequency Hopping](#)[8.2.3 Multiantenna Transmission](#)[8.3 Uplink Control Information](#)[8.3.1 Channel Coding for Uplink Control Information](#)[8.3.2 Modulation of PUCCH](#)[8.3.3 Resource Mapping](#)[8.4 Uplink Reference Signals](#)[8.4.1 Reference Signal Sequence](#)[8.4.2 Resource Mapping of Demodulation Reference Signals](#)[8.4.3 Resource Mapping of Sounding Reference Signals](#)[8.5 Random Access Channels](#)[8.6 H-ARQ in the Uplink](#)[8.6.1 The FDD Mode](#)[8.6.2 The TDD Mode](#)[8.7 Summary and Conclusions](#)[**9 Physical Layer Procedures and Scheduling**](#)[9.1 Hybrid-ARQ Feedback](#)[9.1.1 H-ARQ Feedback for Downlink \(DL\) Transmission](#)[9.1.2 H-ARQ Indicator for Uplink \(UL\) Transmission](#)[9.2 Channel Quality Indicator \(CQI\) Feedback](#)[9.2.1 A Primer on CQI Estimation](#)

Library

Search

[9.2.2 CQI Feedback Modes](#)[9.3 Precoder for Closed-Loop MIMO Operations](#)[9.3.1 Precoder Estimation for Multicarrier Systems](#)[9.3.2 Precoding Matrix Index \(PMI\) and Rank Indication \(RI\) Feedback](#)[9.4 Uplink Channel Sounding](#)[9.5 Buffer Status Reporting in Uplink](#)[9.6 Scheduling and Resource Allocation](#)[9.6.1 Signaling for Scheduling in Downlink and Uplink](#)[9.6.2 Multiuser MIMO Signaling](#)[9.7 Semi-persistent Scheduling for VoIP](#)[9.7.1 Motivation for Semi-persistent Scheduling](#)[9.7.2 Changes in the Signaling Structure](#)[9.8 Cell Search](#)[9.9 Random Access Procedures](#)[9.10 Power Control in Uplink](#)[9.11 Summary and Conclusions](#)

10 Data Flow, Radio Resource Management, and Mobility Management

[10.1 PDCP Overview](#)[10.1.1 Header Compression](#)[10.1.2 Integrity and Ciphering](#)[10.2 MAC/RLC Overview](#)[10.2.1 Data Transfer Modes](#)

Library

Search 

[10.2.2 Purpose of MAC and RLC Layers](#)

[10.2.3 PDU Headers and Formats](#)

[10.2.4 ARQ Procedures](#)

[10.3 RRC Overview](#)

[10.3.1 RRC States](#)

[10.3.2 RRC Functions](#)

[10.4 Mobility Management](#)

[10.4.1 S1 Mobility](#)

[10.4.2 X2 Mobility](#)

[10.4.3 RAN Procedures for Mobility](#)

[10.4.4 Paging](#)

[10.5 Inter-cell Interference Coordination](#)

[10.5.1 Downlink](#)

[10.5.2 Uplink](#)

[10.6 Summary and Conclusions](#)

[Index](#)

Attachment D-1

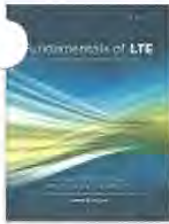

BOOK
Fundamentals of LTE
Arunabha Ghosh 1969-
Upper Saddle River, NJ : Prentice Hall, c2011

Export

-  EXPORT BIBTEX
-  EXPORT RIS
-  REFWORKS
-  MENDELEY
-  ENDNOTE
-  EASYBIB
-  CITATION
-  PERMALINK
-  PRINT
-  E-MAIL



Print Copies

LOCATIONS

Notre Dame, Hesburgh Library
Available • Lower Level Engineering Collection • TK 5103.48325 .F86 2011 

Lower Level Engineering Collection TK 5103.48325 .F86 2011 

Request

Request an electronic copy of an article or book chapter  

Details

Request

Request an electronic copy of an article or book chapter [☑](#) [➤](#)

Details

Title

Fundamentals of LTE

Series

Prentice Hall communications engineering and emerging technologies series.

Contributor

Arunabha Ghosh 1969- [➤](#)

Published

Upper Saddle River, NJ : Prentice Hall

c2011

xxxi, 418 p. : ill. ; 24 cm..

Language

English

Subjects

Long-Term Evolution [Telecommunications] [➤](#)

Identifier

ISBN: 0137033117 (hardcover : alk. paper)

ISBN: 9780137033119 (hardcover : alk. paper)

OCLC : [471787103](#)

Record ID

ndu_aleph002640010

Type

Book

Report a problem with this record [☑](#)

More Links

Notre Dame Catalog [☑](#) [➤](#)

This item in WorldCat [☑](#) [➤](#)

This item in Google Books [☑](#)

Staff MARC View [☑](#) [➤](#)

Need Help?

Chat with us now.

[NO THANKS](#)

[CLICK TO CHAT](#)

Fundamentals of LTE

- **Series:** Prentice Hall communications engineering and emerging technologies series.
- **Contributor:** Arunabha Ghosh 1969-
- **Published:** Upper Saddle River, NJ : Prentice Hall
- **Published:** c2011
- **Format:** xxxi, 418 p. : ill. ; 24 cm..
- **Language:** English
- **Subjects:** Long-Term Evolution [Telecommunications]
- **Identifier:** ISBN: 0137033117 (hardcover : alk. paper); \$C ISBN
- **Record ID:** ndu_aleph002640010
- **Type:** book

Availability and location:

Hesburgh Libraries, University of Notre Dame:

- Available:
 - Notre Dame, Hesburgh Library Lower Level Engineering Collection TK 5103.48325 .F86 2011

Attachment E-1

Leader 00000cam a2200301 a 4500
 005 20101202123027.0
 008 100609s2011 njua b 001 0 eng
 010 ##\$a2010021369
 015 ##\$aGBB057637\$2bnb
 016 7#\$a015545055\$2Uk
 020 ##\$a0137033117 (hardcover : alk. paper)
 020 ##\$a9780137033119 (hardcover : alk. paper)
 035 ##\$b(ybp)40018398814
 035 ##\$a(OCOLC)471787103
 040 ##\$aDLC\$cDLC\$dYDX\$dUKM\$dBTCTA\$dYDXCP\$dIND
 049 ##\$aINDU
 050 00\$aTK 5103.48325\$b.F86 2011
 082 00\$a621.3845/6\$222
 245 00\$aFundamentals of LTE /\$cArunabha Ghosh ... [et al.].
 260 ##\$aUpper Saddle River, NJ :\$bPrentice Hall,\$cc2011.
 300 ##\$axxxi, 418 p. :\$bill. ;\$c24 cm.
 490 1#\$aThe Prentice Hall communications engineering and
 emerging technologies series
 504 ##\$aIncludes bibliographical references and index.
 599 99\$aNEW\$d20101202
 599 99\$aauth\$d20101202
 650 #0\$aLong-Term Evolution (Telecommunications)
 700 1#\$aGhosh, Arunabha,\$d1969-
 830 #0\$aPrentice Hall communications engineering and emerging
 technologies series.
 852 00\$aInNd\$bENGIN\$cGEN\$hTK 5103.48325\$i.F86 2011
 980 ##\$a20101018\$b79.99\$e65.19\$f40018398814\$g1\$i115477
 981 ##\$bEDIAPRV-2011
 994 ##\$aC0\$bIND
 AVA ##\$aNDU50\$bENGIN\$cLower Level Engineering Collection\$dTK
 5103.48325 .F86 2011\$eavailable\$tAvailable\$f1\$g0\$hN\$i5\$jGEN\$k0
 BAR ##\$b00000028560894
 FMT BK
 LDR cam a2200301 a 4500
 SRS ##\$aCommunications engineering and emerging technologies
 series
 SUB ##\$a3GPP Long-Term Evolution (Telecommunications)
 SUB ##\$aLTE (Telecommunications)
 SUL ##\$a3GPP Long-Term Evolution (Telecommunications)
 SUL ##\$aLTE (Telecommunications)
 TYP ##\$aBook
 XYZ ##\$a3GPP Long-Term Evolution (Telecommunications)
 XYZ ##\$aLTE (Telecommunications)

Attachment F-1



Diane Walker <dwalker6@nd.edu>

Favor:

Laura Sill <ljenney@nd.edu>
To: Diane Walker <Diane.Parr.Walker@nd.edu>

Sun, Jan 24, 2021 at 9:03 PM

Hello, Diane,

This title was shipped as part of the North American Approval plan from YPB in 2010. Note our approval processing looked different then, i.e., two week display cycles of shipments and no shelf-ready until 2013.

Here is a summary of what happened with this title:

10/18/2010: Title invoiced by vendor and item prepared to ship from vendor.

10/29/2010: Bibliographic record loaded in Aleph system and order record created automatically using the local 9XX MARC data. Shipment arrives in library Acquisitions sometime around this date. Afterwhich, the shipment is unpacked, displayed for a two-week subject librarian review, taken off display for final invoice processing, and sent to Cataloging for final processing (just prior to Thanksgiving, I would guess).

12/2/2010: Cataloging of book is completed and it is sent to Labelling and delivery to the Engineering Library. This date corresponds to the MARC 005.

=====

Here's the detail with system screen shots:

10/18/2010 = date of the invoice and date of shipping of material from vendor as recorded in YBP/GOBI system.

Title: FUNDAMENTALS OF LTE; ARUNABHA GHOSH ... ET AL
Publisher: PRENTICE HALL
Pub Year: 2011
ISBN: 9780137033119
Place of Publication: UPPER SADDLE RIVER
Country of Origin: US
Page(s): 412 p.
Series Title: PRENTICE HALL COMMUNICATIONS ENGINEERING AND EMERGING TECHNOLOGIES SERIES
Series Type: Unnumbered Series
Series Format: Print
YBP Select: Research-Recommended
Table of contents
Series ID: 32098
Content Level: ADV-AC
LC Class: TN5105.48325.F96 2010
Subject Headings: LONG-TERM EVOLUTION (TELECOMMUNICATIONS)
Approval Note: TEXTBOOK-ADV. UNDERGRAD.
Format: Textbook-adv.
Language: English
US List: 79.99 USD
LCCN: 2010-021069
OCLC: OCN471787100
US Status: Out of print. Sourced to an out-of-print supplier.
NON-RETURN/NON-CANCEL YBP-US
Handled On Approval YBP-US: 10/18/2010
Last Received YBP-US: 8/6/2012
Library Note: Add...

Library History

Title: FUNDAMENTALS OF LTE; ARUNABHA GHOSH ... ET AL
Author:
Pub Year: 2011
Series Title: PRENTICE HALL COMMUNICATIONS ENGINEERING AND EMERGING TECHNOLOGIES SERIES.
Publisher: PRENTICE HALL
Series ID: 32098
ISBN: 9780137033119
Binding: Cloth
Series Type: Unnumbered Series

Action	Date	Qty	Descriptor	Subaccount	Fund/ Other	PO#	Initials	Submitted By	Invoice#	Tracking#
Shipped	10/18/2010	1	US N AMER AP HUMAN	8087-11	ENGIN				115477	1705E3950368316626
Holdings			US HQ	8087-99						

[library activity / 45 sold](#)

980 bibliographic field - local MARC field/subfields used to pass vendor system data to library. Used to automatically populate the Aleph order record. We retain the 9XX fields for assessment and reference. Includes the invoice date, list and net price, vendor order key, quantity and invoice number.

```
980 ##$a20101018$b79.99$c65.19$f40018398814$g1$i115477
981 ##$bEDIAPRV-2011
```

This snippet is from our GOBI record load specifications document:

1/25/2021

University of Notre Dame Mail - A Favor:

980		a	Invoice date (yyyymmdd)
980		b	List price (explicit decimal)
980		e	Net price (explicit decimal)
980		f	YBP order key
980		g	Quantity
980		i	Invoice number
981		b	Fund code (see below)
981		v	Fund code (see below)

Here is our invoice for this item (see red marked item), the 10/20/2010 date, invoice number, prices, etc.

RETURN BOOKS ONLY TO:
YBP Library Services
999 Maple St.
Cantonctock, NH 03229

YBP Library Services
A Baker and Taylor Company
PO Box 27781
Atlanta, GA 30384-7991
(803) 746-3162 (800) 256-3774 FAX (803) 746-0628 FEO: ID #02-0302143

T# 220
App. Date 10/20/10
PAGE 1

SOLD TO: UNIVERSITY OF NOTRE DAME
HESBURGH LIBRARY
ACQUISITIONS DEPARTMENT
NOTRE DAME, IN 46556

BY: UNIVERSITY OF NOTRE DAME
APPROVAL
120 HESBURGH LIBRARY
NOTRE DAME, IN 46556

115477

INVOICE DATE	TERMS	DUE DATE	CUSTOMER ORDER NUMBER	CUSTOMER NUMBER
10/18/10	net 30	11/17/10	M AMERICAN APPR	SUS7-11

QUANTITY	PURCHASE ORDER #	AUTHOR	ISBN	UNIT	LIST PRICE	DISCOUNT	SINGLE NET	NET AMOUNT
1		ACTIVITY SYSTEMS ANALYSIS METHODS: UNDERSTANDI	1441953200	PSY LB	129.00	18.5%	105.14	105.14
2		COLGAN, B 0786448873 WORLDHIS		D	38.00	.0%	38.00	38.00
1		AYALA, FR 0801897548 BIOS		QB	12.95	18.5%	10.55	10.55
1		BATESON, 0301246435 GENI		HQ	25.95	18.5%	21.15	21.15
1		RAHIMI, S 047040745X ENGIN		QA	135.00	18.5%	110.03	110.03
1		0137033317 ENGIN		TK	79.99	18.5%	65.19	65.19
1		0765690821 AMER		E	229.00	18.5%	186.64	186.64
1		MAGAZINE 0821418188 WORLDHIS		DT	28.95	10.0%	24.26	24.26
1		GROVES, D 0820336793 ENGLISH		PS	16.95	10.0%	15.26	15.26
1		BOURGEAUL 1590304950 RELIG		BS	16.95	10.0%	15.26	15.26
1		BLANCHOT, 082322998X FRENCH		PQ	28.00	10.0%	25.20	25.20
1		0470121947 CHEMPHYE		RS	95.95	18.5%	81.46	81.46
1		CRAGG, PE 9048125812 CHEMPHYE		QD	129.00	18.5%	105.14	105.14
1		WOOD, GEO 0813929032 AMER		E	30.00	18.5%	24.45	24.45

10/29/2020 = date bibliographic record was first loaded into the library Aleph system, creating the order record; Acquisitions approval display cycle starts (see detail above).

1. Order Display | 2. General | 3. Vendor | 4. Q

Order Number:

Additional Order No.1:

Order ISBN/ISSN:

Open Date:

Order Date:

12/2/2010: Date of completion of cataloging. December 1, 2010 we overlaid the vendor record with a more complete record from OCLC, and completed the cataloging on December 2nd. Some sort of Aleph fix routine was applied in 2016 (I can check more on this, if you wish).

1/25/2021

University of Notre Dame Mail - A Favor:

Cataloger	Level	Date	Hour
OCLC:fer	00	Dec-01-20	03:52 PM 10
PBALES	20	Dec-02-20	12:30 PM 10
LDRFIX		Dec-31-20	11:24 AM 16

MARC 005: Date/time of last record update: December 2, 2010, 12:30 p.m. - last cataloging update
005 20101202123027.0

Laura Sill (she/her/hers)
Director, Metadata Services
Interim Head, Electronic Resources & Collection Metadata Management
Hesburgh Libraries

University of Notre Dame
406 Hesburgh Library
Notre Dame, IN 46556
o: (574) 631-4036
c: (574) 303-8023
e: ljenny@nd.edu



[Quoted text hidden]

Attachment G-1



Search WorldCat

Search

[Advanced Search](#) [Find a Library](#)

[Cite/Export](#) [Print](#) [E-mail](#) [Share](#) [Permalink](#)

[Add to list](#) [Add tags](#) [Write a review](#) Rate this item: 1 2 3 4 5

Fundamentals of LTE

Author: [Arunabha Ghosh](#); [Jun Zhang](#); [Jeffrey G Andrews](#); [Rias Muhamed](#)
 Publisher: Uttar Pradesh, India ; Pearson India Education Services : [2018] ©2011
 Edition/Format: Print book : English [View all editions and formats](#)
 Rating: (not yet rated) [0 with reviews - Be the first.](#)
 Subjects: [Long-Term Evolution \(Telecommunications\)](#)
 More like this: [Similar Items](#)

Get a Copy

[Find a copy in the library](#)

[AbeBooks](#) \$10.38

[Amazon](#) \$23.91

Find a copy in the library

Enter your location: [Find libraries](#)

Submit a complete postal address for best results.

Displaying libraries 1-6 out of 199 for all 18 editions (Indiana, USA)

Show libraries holding [just this edition](#)

<< First < Prev 1 2 3 Next > Last >>

Library	Held formats	Distance	
1. Miami University Libraries King Library Oxford, OH 45056 United States	Book	91 miles MAP IT	Library info Ask a librarian Add to favorites
2. University of Notre Dame Hesburgh Library Notre Dame, IN 46556 United States	Book	99 miles MAP IT	Library info Add to favorites
3. Xavier University McDonald Memorial Library Cincinnati, OH 45207 United States	Book	117 miles MAP IT	Library info Ask a librarian Add to favorites
4. Kirkland & Ellis LLP Library Chicago, IL 60654 United States	Book	137 miles MAP IT	Library info Add to favorites
5. College of DuPage Library Glen Ellyn, IL 60137 United States	Book	149 miles MAP IT	Library info Ask a librarian Add to favorites
6. Schaumburg Township District Library Schaumburg, IL 60193 United States	Book	158 miles MAP IT	Library info Ask a librarian Add to favorites

<< First < Prev 1 2 3 Next > Last >>

Details

Document Type: Book

All Authors / Contributors: [Arunabha Ghosh](#); [Jun Zhang](#); [Jeffrey G Andrews](#); [Rias Muhamed](#)
Find more information about:

ISBN: 9789353062392 935306239X

OCLC Number: 1079367343

Notes: "Indian Subcontinent Reprint."

Description: xxxi, 418 pages : illustrations ; 23 cm

Contents: Evolution of cellular technologies --
Part I: LTE tutorials --
Wireless fundamentals --
Multicarrier modulation --
Frequency domain multiple access : OFDMA and SC-FDMA --
Multiple antenna transmission and reception --
Part II: The LTE standard --
Overview and channel structure of LTE --
Downlink transport channel processing --
Uplink transport channel processing --
Physical layer procedures and scheduling --
Data flow, radio resource management, and mobility management.

Responsibility: Arunabha Ghosh, Jun Zhang, Jeffrey G. Andrews, Rias Muhamed.

Reviews

User-contributed reviews

[Add a review](#) and share your thoughts with other readers. Be the first.

Tags

[Add tags](#) for "Fundamentals of LTE". Be the first.

Similar Items

Related Subjects: (1)

[Long-Term Evolution \(Telecommunications\)](#)

Linked Data

Attachment H-1

LIBRARY | CATALOG

← < 1 of 1

BOOK

Fundamentals of LTE

Full Record

MARC Tags

Main title

Fundamentals of LTE / Arunabha Ghosh ... [et al.].

Published/Created

Upper Saddle River, NJ : Prentice Hall, c2011.

Request this Item

 LC Find It

More Information >

LCCN Permalink <https://lccn.loc.gov/2010021369>

Description xxxi, 418 p. : ill. ; 24 cm.

ISBN 0137033117 (hardcover : alk. paper)
9780137033119 (hardcover : alk. paper)

LC classification TK5103.48325 .F86 2011

Related names Ghosh, Arunabha, 1969-

LC Subjects [Long-Term Evolution \(Telecommunications\)](#)

Browse by shelf order [TK5103.48325](#)

1/7/2021

LC Catalog - Item Information (Full Record)

Notes

Includes bibliographical references and index.

Series

The Prentice Hall communications engineering and emerging technologies series
[Prentice Hall communications engineering and emerging technologies series.](#)

LCCN

2010021369

Dewey class no.

621.3845/6

National bib agency no.

015545055

Other system no.

(OCoLC)ocn471787103

Type of material

Book

Item Availability

>

Shelf Location

FLM2016 064014

CALL NUMBER

[TK5103.48325 .F86 2011 OVERFLOWJ34](#)

Request in

Jefferson or Adams Building Reading Rooms (FLM2)

Status

Not Charged

Attachment I-1

LIBRARY | CATALOG



1 of 1

BOOK

Fundamentals of LTE

Full Record

MARC Tags

000 01267cam a22003015a 4500
 001 16273896
 005 20160728093048.0
 008 100609s2011 njua b 001 0 eng
 906 __ |a 7 |b cbc |c orignew |d 1 |e ecp |f 20 |g y-gencatlg
 925 0_ |a acquire |b 1 shelf copy |x policy default
 925 1_ |a acquire |b 2 shelf copies |x policy default |e claim1 2010-11-15
 955 __ |b rc02 2011-02-15 z-processor |i rc02 2011-02-15 to BCCD |t rf18 2011-04-14 copy 2 added
 010 __ |a 2010021369
 016 7_ |a 015545055 |2 Uk
 020 __ |a 0137033117 (hardcover : alk. paper)
 020 __ |a 9780137033119 (hardcover : alk. paper)
 035 __ |a (OCoLC)ocn471787103
 040 __ |a DLC |c DLC |d YDX |d UKM |d BTCTA |d YDXCP |d DLC
 050 00 |a TK5103.48325 |b .F86 2011
 082 00 |a 621.3845/6 |2 22
 245 00 |a Fundamentals of LTE / |c Arunabha Ghosh ... [et al.].
 260 __ |a Upper Saddle River, NJ : |b Prentice Hall, |c c2011.
 300 __ |a xxxi, 418 p. : |b ill. ; |c 24 cm.
 490 1_ |a The Prentice Hall communications engineering and emerging technologies series
 504 __ |a Includes bibliographical references and index.
 650 _0 |a Long-Term Evolution (Telecommunications)
 700 1_ |a Ghosh, Arunabha, |d 1969-

830 _0 |a Prentice Hall communications engineering and emerging technologies series.

[Request this Item](#)

[LC Find It](#)

Item Availability >

Shelf Location	FLM2016 064014
CALL NUMBER	TK5103.48325 .F86 2011 OVERFLOWJ34
Request in	Jefferson or Adams Building Reading Rooms (FLM2)
Status	Not Charged

Attachment J-1



Search WorldCat

Search

[Advanced Search](#) [Find a Library](#)

[<< Return to Search Results](#) [Cite/Export](#) [Print](#) [E-mail](#) [Share](#) [Permalink](#)

[Add to list](#) [Add tags](#) [Write a review](#) Rate this item: 1 2 3 4 5

Fundamentals of LTE

Author: [Arunabha Ghosh](#); [Jun Zhang](#); [Jeffrey G Andrews](#); [Rias Muhamed](#)

Publisher: Uttar Pradesh, India ; Pearson India Education Services : [2018] ©2011

Edition/Format: Print book : English [View all editions and formats](#)

Rating: (not yet rated) [0 with reviews - Be the first.](#)

Subjects: [Long-Term Evolution \(Telecommunications\)](#)

More like this [Similar Items](#)

Get a Copy

[Find a copy in the library.](#)

[AbeBooks](#) \$10.38

[Amazon](#) \$25.02

Find a copy in the library

Enter your location:

Submit a complete postal address for best results.

Displaying libraries 1-6 out of 199 for all 18 editions (Washington, DC, USA)

Show libraries holding [just this edition](#)

<< First < Prev 1 2 3 Next > Last >>

Library	Held formats	Distance	
1. Consumer Financial Protection Bureau Washington, DC 20552 United States	Book	1 mile MAP IT	Library info Add to favorites
2. Library of Congress Washington, DC 20540 United States	Book	2 miles MAP IT	Library info Ask a librarian Add to favorites
3. Montgomery College Library Rockville, MD 20850 United States	Book	15 miles MAP IT	Library info Ask a librarian Add to favorites
4. George Mason University Fenwick Library Fairfax, VA 22030 United States	Book	16 miles MAP IT	Library info Add to favorites
5. Space Telescope Science Institute Library STScI Library Baltimore, MD 21218 United States	Book	37 miles MAP IT	Library info Add to favorites
6. Virginia Commonwealth University VCU Libraries Richmond, VA 23284 United States	Book	97 miles MAP IT	Library info Ask a librarian Add to favorites

<< First < Prev 1 2 3 Next > Last >>

Details

Document Type: Book

All Authors / Contributors: [Arunabha Ghosh](#); [Jun Zhang](#); [Jeffrey G Andrews](#); [Rias Muhamed](#)
Find more information about:

ISBN: 9789353062392 935306239X

OCLC Number: 1079367343

Notes: "Indian Subcontinent Reprint."

Description: xxxi, 418 pages : illustrations ; 23 cm

Contents: Evolution of cellular technologies --
Part I: LTE tutorials --
Wireless fundamentals --
Multicarrier modulation --
Frequency domain multiple access : OFDMA and SC-FDMA --
Multiple antenna transmission and reception --
Part II: The LTE standard --
Overview and channel structure of LTE --
Downlink transport channel processing --
Uplink transport channel processing --
Physical layer procedures and scheduling --
Data flow, radio resource management, and mobility management.

Responsibility: Arunabha Ghosh, Jun Zhang, Jeffrey G. Andrews, Rias Muhamed.

Reviews

User-contributed reviews

[Add a review](#) and share your thoughts with other readers. Be the first

Tags

[Add tags](#) for "Fundamentals of LTE". Be the first

Similar Items

Related Subjects: (1)

[Long-Term Evolution \(Telecommunications\)](#)

Linked Data

Attachment A-2

LTE for UMTS – OFDMA and SC-FDMA Based Radio Access

LTE for UMTS: OFDMA and SC-FDMA Based Radio Access Edited by Harri Holma and Antti Toskala
© 2009 John Wiley & Sons, Ltd. ISBN: 978-0-470-99401-6

LTE for UMTS – OFDMA and SC-FDMA Based Radio Access

Edited by

Harri Holma and Antti Toskala

both of Nokia Siemens Networks, Finland



John Wiley & Sons, Ltd

This edition first published 2009
© 2009 John Wiley & Sons Ltd.

Registered office

John Wiley & Sons Ltd, The Atrium, Southern Gate, Chichester, West Sussex, PO19 8SQ, United Kingdom

For details of our global editorial offices, for customer services and for information about how to apply for permission to reuse the copyright material in this book please see our website at www.wiley.com.

The right of the author to be identified as the author of this work has been asserted in accordance with the Copyright, Designs and Patents Act 1988.

All rights reserved. No part of this publication may be reproduced, stored in a retrieval system, or transmitted, in any form or by any means, electronic, mechanical, photocopying, recording or otherwise, except as permitted by the UK Copyright, Designs and Patents Act 1988, without the prior permission of the publisher.

Wiley also publishes its books in a variety of electronic formats. Some content that appears in print may not be available in electronic books.

Designations used by companies to distinguish their products are often claimed as trademarks. All brand names and product names used in this book are trade names, service marks, trademarks or registered trademarks of their respective owners. The publisher is not associated with any product or vendor mentioned in this book. This publication is designed to provide accurate and authoritative information in regard to the subject matter covered. It is sold on the understanding that the publisher is not engaged in rendering professional services. If professional advice or other expert assistance is required, the services of a competent professional should be sought.

LTE is a trademark, registered by ETSI for the benefit of the 3GPP Partners

Library of Congress Cataloging-in-Publication Data

LTE for UMTS-OFDMA and SC-FDMA based radio access / edited by Harri Holma, Antti Toskala.
p. cm.

Includes bibliographical references and index.

ISBN 978-0-470-99401-6 (cloth : alk. paper) 1. Universal Mobile Telecommunications System. 2. Wireless communication systems--Standards. 3. Mobile communication systems--Standards. 4. Global system for mobile communications. I. Holma, Harri, 1970- II. Toskala, Antti.

TK5103.4883.L78 2009

621.3845'6--dc22

2008052792

A catalogue record for this book is available from the British Library.

ISBN 9780470994016 (H/B)

Set in 10/12 pt Times by Sparks, Oxford – www.sparkspublishing.com
Printed and bound in Great Britain by Antony Rowe, Chippenham, UK

Contents

Preface	xiii
Acknowledgements	xv
List of Abbreviations	xvii
1 Introduction	1
<i>Harri Holma and Antti Toskala</i>	
1.1 Mobile Voice Subscriber Growth	1
1.2 Mobile Data Usage Growth	2
1.3 Wireline Technologies Evolution	3
1.4 Motivation and Targets for LTE	4
1.5 Overview of LTE	5
1.6 3GPP Family of Technologies	7
1.7 Wireless Spectrum	8
1.8 New Spectrum Identified by WRC-07	10
1.9 LTE-Advanced	11
2 LTE Standardization	13
<i>Antti Toskala</i>	
2.1 Introduction	13
2.2 Overview of 3GPP Releases and Process	13
2.3 LTE Targets	14
2.4 LTE Standardization Phases	16
2.5 Evolution Beyond Release 8	18
2.6 LTE-Advanced for IMT-Advanced	19
2.7 LTE Specifications and 3GPP Structure	21
References	22
3 System Architecture Based on 3GPP SAE	23
<i>Atte Lämsisalmi and Antti Toskala</i>	
3.1 System Architecture Evolution in 3GPP	23
3.2 Basic System Architecture Configuration with only E-UTRAN Access Network	25

3.2.1	Overview of Basic System Architecture Configuration	25
3.2.2	Logical Elements in Basic System Architecture Configuration	26
3.2.3	Self-configuration of S1-MME and X2 interfaces	34
3.2.4	Interfaces and Protocols in Basic System Architecture Configuration	35
3.2.5	Roaming in Basic System Architecture Configuration	39
3.3	System Architecture with E-UTRAN and Legacy 3GPP Access Networks	40
3.3.1	Overview of 3GPP Inter-working System Architecture Configuration	40
3.3.2	Additional and Updated Logical Elements in 3GPP Inter-working System Architecture Configuration	42
3.3.3	Interfaces and Protocols in 3GPP Inter-working System Architecture Configuration	44
3.3.4	Inter-working with Legacy 3GPP CS Infrastructure	44
3.4	System Architecture with E-UTRAN and Non-3GPP Access Networks	45
3.4.1	Overview of 3GPP and Non-3GPP Inter-working System Architecture Configuration	45
3.4.2	Additional and Updated Logical Elements in 3GPP Inter-working System Architecture Configuration	47
3.4.3	Interfaces and Protocols in Non-3GPP Inter-working System Architecture Configuration	50
3.4.4	Roaming in Non-3GPP Inter-working System Architecture Configuration	51
3.5	Inter-working with cdma2000® Access Networks	51
3.5.1	Architecture for cdma2000® HRPD Inter-working	51
3.5.2	Additional and Updated Logical Elements for cdma2000® HRPD Inter-working	54
3.5.3	Protocols and Interfaces in cdma2000® HRPD Inter-working	55
3.5.4	Inter-working with cdma2000® 1xRTT	56
3.6	IMS Architecture	56
3.6.1	Overview	56
3.6.2	Session Management and Routing	58
3.6.3	Databases	59
3.6.4	Services Elements	59
3.6.5	Inter-working Elements	59
3.7	PCC and QoS	60
3.7.1	PCC	60
3.7.2	QoS	63
	References	65
4	Introduction to OFDMA and SC-FDMA and to MIMO in LTE	67
	<i>Antti Toskala and Timo Lunttila</i>	
4.1	Introduction	67
4.2	LTE Multiple Access Background	67
4.3	OFDMA Basics	70
4.4	SC-FDMA Basics	76
4.5	MIMO Basics	80
4.6	Summary	82
	References	82

5	Physical Layer	83
	<i>Antti Toskala, Timo Lunttila, Esa Tirola, Kari Hooli and Juha Korhonen</i>	
5.1	Introduction	83
5.2	Transport Channels and Their Mapping to the Physical Channels	83
5.3	Modulation	85
5.4	Uplink User Data Transmission	86
5.5	Downlink User Data Transmission	89
5.6	Uplink Physical Layer Signaling Transmission	93
	5.6.1 Physical Uplink Control Channel (PUCCH)	94
	5.6.2 PUCCH Configuration	97
	5.6.3 Control Signaling on PUSCH	101
	5.6.4 Uplink Reference Signals	103
5.7	PRACH Structure	109
	5.7.1 Physical Random Access Channel	109
	5.7.2 Preamble Sequence	110
5.8	Downlink Physical Layer Signaling Transmission	112
	5.8.1 Physical Control Format Indicator Channel (PCFICH)	112
	5.8.2 Physical Downlink Control Channel (PDCCH)	113
	5.8.3 Physical HARQ Indicator Channel (PHICH)	115
	5.8.4 Downlink Transmission Modes	115
	5.8.5 Physical Broadcast Channel (PBCH)	116
	5.8.6 Synchronization Signal	117
5.9	Physical Layer Procedures	117
	5.9.1 HARQ Procedure	118
	5.9.2 Timing Advance	119
	5.9.3 Power Control	119
	5.9.4 Paging	120
	5.9.5 Random Access Procedure	120
	5.9.6 Channel Feedback Reporting Procedure	123
	5.9.7 Multiple Input Multiple Output (MIMO) Antenna Technology	129
	5.9.8 Cell Search Procedure	130
	5.9.9 Half Duplex Operation	130
5.10	UE Capability Classes and Supported Features	131
5.11	Physical Layer Measurements	132
	5.11.1 eNodeB Measurements	132
	5.11.2 UE Measurements and Measurement Procedure	133
5.12	Physical Layer Parameter Configuration	133
5.13	Summary	134
	References	135
6	LTE Radio Protocols	137
	<i>Antti Toskala and Woonhee Hwang</i>	
6.1	Introduction	137
6.2	Protocol Architecture	137
6.3	Medium Access Control	139
	6.3.1 Logical Channels	140
	6.3.2 Data Flow in MAC Layer	142

6.4	Radio Link Control Layer	143
6.4.1	RLC Modes of Operation	144
6.4.2	Data Flow in RLC Layer	145
6.5	Packet Data Convergence Protocol	145
6.6	Radio Resource Control (RRC)	146
6.6.1	UE States and State Transitions Including Inter-RAT	147
6.6.2	RRC Functions and Signaling Procedures	148
6.7	X2 Interface Protocols	158
6.7.1	Handover on X2 Interface	159
6.7.2	Load Management	160
6.8	Early UE Handling in LTE	162
6.9	Summary	162
	References	163
7	Mobility	165
	<i>Chris Callender, Harri Holma, Jarkko Koskela and Jussi Reunanen</i>	
7.1	Introduction	165
7.2	Mobility Management in Idle State	166
7.2.1	Overview of Idle Mode Mobility	166
7.2.2	Cell Selection and Reselection Process	167
7.2.3	Tracking Area Optimization	169
7.3	Intra-LTE Handovers	170
7.3.1	Procedure	170
7.3.2	Signaling	171
7.3.3	Handover Measurements	174
7.3.4	Automatic Neighbor Relations	174
7.3.5	Handover Frequency	175
7.3.6	Handover Delay	177
7.4	Inter-system Handovers	177
7.5	Differences in E-UTRAN and UTRAN Mobility	178
7.6	Summary	179
	References	180
8	Radio Resource Management	181
	<i>Harri Holma, Troels Kolding, Daniela Laselva, Klaus Pedersen, Claudio Rosa and Ingo Viering</i>	
8.1	Introduction	181
8.2	Overview of RRM Algorithms	181
8.3	Admission Control and QoS Parameters	182
8.4	Downlink Dynamic Scheduling and Link Adaptation	184
8.4.1	Layer 2 Scheduling and Link Adaptation Framework	184
8.4.2	Frequency Domain Packet Scheduling	185
8.4.3	Combined Time and Frequency Domain Scheduling Algorithms	187
8.4.4	Packet Scheduling with MIMO	188
8.4.5	Downlink Packet Scheduling Illustrations	189
8.5	Uplink Dynamic Scheduling and Link Adaptation	192
8.5.1	Signaling to Support Uplink Link Adaptation and Packet Scheduling	196

8.5.2	Uplink Link Adaptation	199
8.5.3	Uplink Packet Scheduling	200
8.6	Interference Management and Power Settings	204
8.6.1	Downlink Transmit Power Settings	205
8.6.2	Uplink Interference Coordination	206
8.7	Discontinuous Transmission and Reception (DTX/DRX)	207
8.8	RRC Connection Maintenance	209
8.9	Summary	209
	References	210
9	Performance	213
	<i>Harri Holma, Pasi Kinnunen, István Z. Kovács, Kari Pajukoski, Klaus Pedersen and Jussi Reunanen</i>	
9.1	Introduction	213
9.2	Layer 1 Peak Bit Rates	213
9.3	Terminal Categories	216
9.4	Link Level Performance	217
9.4.1	Downlink Link Performance	217
9.4.2	Uplink Link Performance	219
9.5	Link Budgets	222
9.6	Spectral Efficiency	224
9.6.1	System Deployment Scenarios	224
9.6.2	Downlink System Performance	228
9.6.3	Uplink System Performance	231
9.6.4	Multi-antenna MIMO Evolution Beyond 2×2	234
9.6.5	Higher Order Sectorization (Six Sectors)	238
9.6.6	Spectral Efficiency as a Function of LTE Bandwidth	240
9.6.7	Spectral Efficiency Evaluation in 3GPP	242
9.6.8	Benchmarking LTE to HSPA	243
9.7	Latency	244
9.7.1	User Plane Latency	244
9.8	LTE Refarming to GSM Spectrum	246
9.9	Dimensioning	247
9.10	Capacity Management Examples from HSPA Networks	249
9.10.1	Data Volume Analysis	250
9.10.2	Cell Performance Analysis	252
9.11	Summary	256
	References	257
10	Voice over IP (VoIP)	259
	<i>Harri Holma, Juha Kallio, Markku Kuusela, Petteri Lundén, Esa Malkamäki, Jussi Ojala and Haiming Wang</i>	
10.1	Introduction	259
10.2	VoIP Codecs	259
10.3	VoIP Requirements	261
10.4	Delay Budget	262
10.5	Scheduling and Control Channels	263

10.6	LTE Voice Capacity	265
10.7	Voice Capacity Evolution	271
10.8	Uplink Coverage	273
10.9	Circuit Switched Fallback for LTE	275
10.10	Single Radio Voice Call Continuity (SR-VCC)	277
10.11	Summary	280
	References	281
11	Performance Requirements	283
	<i>Andrea Ancora, Iwajlo Angelow, Dominique Brunel, Chris Callender, Harri Holma, Peter Muszynski, Earl McCune and Laurent Noël</i>	
11.1	Introduction	283
11.2	Frequency Bands and Channel Arrangements	283
	11.2.1 Frequency Bands	283
	11.2.2 Channel Bandwidth	285
	11.2.3 Channel Arrangements	287
11.3	eNodeB RF Transmitter	288
	11.3.1 Operating Band Unwanted Emissions	288
	11.3.2 Coexistence with Other Systems on Adjacent Carriers Within the Same Operating Band	290
	11.3.3 Coexistence with Other Systems in Adjacent Operating Bands	292
	11.3.4 Transmitted Signal Quality	295
11.4	eNodeB RF Receiver	300
	11.4.1 Reference Sensitivity Level	300
	11.4.2 Dynamic Range	301
	11.4.3 In-channel Selectivity	301
	11.4.4 Adjacent Channel Selectivity (ACS) and Narrow-band Blocking	303
	11.4.5 Blocking	304
	11.4.6 Receiver Spurious Emissions	306
	11.4.7 Receiver Intermodulation	306
11.5	eNodeB Demodulation Performance	307
	11.5.1 PUSCH	307
	11.5.2 PUCCH	309
	11.5.3 PRACH	310
11.6	UE Design Principles and Challenges	311
	11.6.1 Introduction	311
	11.6.2 RF Subsystem Design Challenges	311
	11.6.3 RF–Baseband Interface Design Challenges	318
	11.6.4 LTE vs HSDPA Baseband Design Complexity	324
11.7	UE RF Transmitter	327
	11.7.1 LTE UE Transmitter Requirement	327
	11.7.2 LTE Transmit Modulation Accuracy, EVM	328
	11.7.3 Desensitization for Band and Bandwidth Combinations (Desense)	329
	11.7.4 Transmitter Architecture	329
11.8	UE RF Receiver Requirements	331
	11.8.1 Reference Sensitivity Level	331
	11.8.2 Introduction to UE Self-desensitization Contributors in FDD UEs	336

11.8.3	ACS, Narrowband Blockers and ADC Design Challenges	341
11.8.4	EVM Contributors: A Comparison Between LTE and WCDMA Receivers	348
11.9	UE Demodulation Performance	352
11.9.1	Transmission Modes	352
11.9.2	Channel Modeling and Estimation	354
11.9.3	Demodulation Performance	356
11.10	Requirements for Radio Resource Management	358
11.10.1	Idle State Mobility	360
11.10.2	Connected State Mobility when DRX is Not Active	360
11.10.3	Connected State Mobility when DRX is Active	362
11.10.4	Handover Execution Performance Requirements	363
11.11	Summary	364
	References	364
12	LTE TDD Mode	367
	<i>Che Xiangguang, Troels Kolding, Peter Skov, Wang Haiming and Antti Toskala</i>	
12.1	Introduction	367
12.2	LTE TDD Fundamentals	368
12.2.1	LTE TDD Frame Structure	369
12.2.2	Asymmetric Uplink/Downlink Capacity Allocation	371
12.2.3	Co-existence with TD-SCDMA	371
12.2.4	Channel Reciprocity	372
12.2.5	Multiple Access Schemes	373
12.3	TDD Control Design	374
12.3.1	Common Control Channels	374
12.3.2	Sounding Reference Signal	376
12.3.3	HARQ Process and Timing	376
12.3.4	HARQ Design for UL TTI Bundling	379
12.3.5	UL HARQ-ACK/NACK Transmission	380
12.3.6	DL HARQ-ACK/NACK Transmission	380
12.3.7	DL HARQ-ACK/NACK Transmission with SRI and/or CQI over PUCCH	381
12.4	Semi-persistent Scheduling	381
12.5	MIMO and Dedicated Reference Signals	383
12.6	LTE TDD Performance	385
12.6.1	Link Performance	386
12.6.2	Link Budget and Coverage for TDD System	386
12.6.3	System Level Performance	389
12.6.4	Evolution of LTE TDD	396
12.7	Summary	396
	References	397
13	HSPA Evolution	399
	<i>Harri Holma, Karri Ranta-aho and Antti Toskala</i>	
13.1	Introduction	399
13.2	Discontinuous Transmission and Reception (DTX/DRX)	400

13.3	Circuit Switched Voice on HSPA	401
13.4	Enhanced FACH and RACH	404
13.5	Downlink MIMO and 64QAM	405
13.6	Dual Carrier HSDPA	407
13.7	Uplink 16QAM	409
13.8	Layer 2 Optimization	410
13.9	Single Frequency Network (SFN) MBMS	411
13.10	Architecture Evolution	412
13.11	Summary	414
	References	415
Index		417

Preface

The number of mobile subscribers has increased tremendously in recent years. Voice communication has become mobile in a massive way and the mobile is the preferred way for voice communication. At the same time the data usage has grown fast in those networks where 3GPP High Speed Packet Access (HSPA) was introduced indicating that the users find value in broadband wireless data. The average data consumption exceeds hundreds of Megabytes per subscriber per month. The end users expect data performance similar to the fixed lines. The operators request high data capacity with low cost of data delivery. 3GPP Long Term Evolution (LTE) is designed to meet those targets. This book presents 3GPP LTE standard in Release 8 and describes its expected performance.

The book is structured as follows. Chapter 1 presents an introduction. The standardization background and process is described in Chapter 2. The system architecture evolution (SAE) is presented in Chapter 3, and the basics of air interface modulation choices in Chapter 4. Chapter 5 describes 3GPP LTE physical layer solutions, and Chapter 6 protocol solutions. The mobility

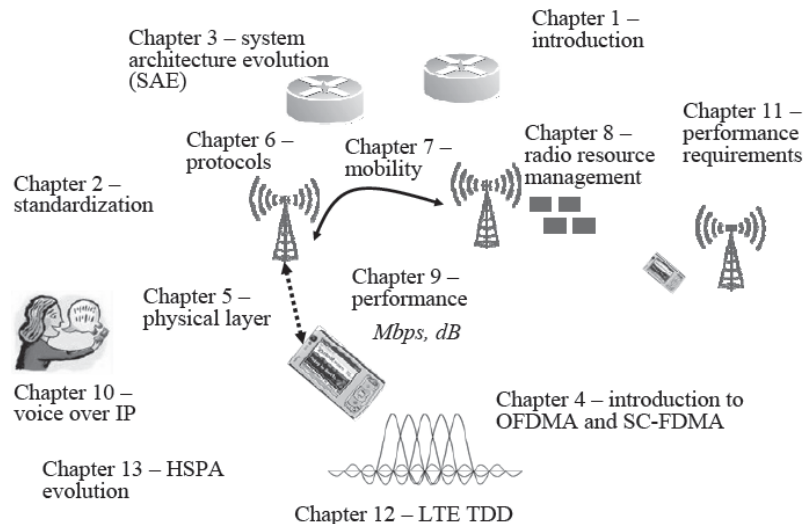

Figure 0.1 Contents of the book

aspects are addressed in Chapter 7, and the radio resource management in Chapter 8. The radio and end-to-end performance is illustrated in Chapter 9. The voice performance is presented in Chapter 10. Chapter 11 explains the 3GPP performance requirements. Chapter 12 presents the main LTE Time Division Duplex (TDD). Chapter 13 describes HSPA evolution in 3GPP Releases 7 and 8.

LTE can access a very large global market – not only GSM/UMTS operators, but also CDMA operators and potentially also fixed network service providers. The potential market can attract a large number of companies to the market place pushing the economies of scale which enable wide scale LTE adoption with lower cost. This book is particularly designed for chip set and mobile vendors, network vendors, network operators, application developers, technology managers and regulators who would like to get a deeper understanding of LTE technology and its capabilities.

Acknowledgements

The editors would like to acknowledge the hard work of the contributors from Nokia Siemens Networks, Nokia, ST-Ericsson and Nomor Research: Andrea Ancora, Iwajlo Angelow, Dominique Brunel, Chris Callender, Kari Hooli, Woonhee Hwang, Juha Kallio, Matti Kiiski, Pasi Kinnunen, Troels Kolding, Juha Korhonen, Jarkko Koskela, Istvan Kovacs, Markku Kuusela, Daniela Laselva, Earl McCune, Peter Muszynski, Petteri Lunden, Timo Lunttila, Atte Länsisalmi, Esa Malkamäki, Laurent Noel, Jussi Ojala, Kari Pajukoski, Klaus Pedersen, Karri Ranta-aho, Jussi Reunanen, Haiming Wang, Peter Skov, Esa Tirola, Ingo Viering, Haiming Wang and Che Xiangguang.

We also would like to thank the following colleagues for their valuable comments: Asbjörn Grovlen, Jorma Kaikkonen, Michael Koonert, Peter Merz, Preben Mogensen, Sari Nielsen, Gunnar Nitsche, Miikka Poikselkä, Sabine Rössel, Benoist Sebire, Issam Toufik and Helen Waite.

The editors appreciate the fast and smooth editing process provided by Wiley and especially Sarah Tilley, Mark Hammond, Katharine Unwin, Brett Wells, Tom Fryer and Mitch Fitton.

We are grateful to our families, as well as the families of all the authors, for their patience during the late night and weekend editing sessions.

The editors and authors welcome any comments and suggestions for improvements or changes that could be implemented in forthcoming editions of this book. The feedback is welcome to editors' email addresses harri.holma@nsn.com and antti.toskala@nsn.com.

List of Abbreviations

3GPP	Third Generation Partnership Project
AAA	Authentication, Authorization and Accounting
ACF	Analog Channel Filter
ACIR	Adjacent Channel Interference Rejection
ACK	Acknowledgement
ACLR	Adjacent Channel Leakage Ratio
ACS	Adjacent Channel Selectivity
ADC	Analog-to-Digital Conversion
ADSL	Asymmetric Digital Subscriber Line
AKA	Authentication and Key Agreement
AM	Acknowledged Mode
AMBR	Aggregate Maximum Bit Rate
AMD	Acknowledged Mode Data
AMR	Adaptive Multi-Rate
AMR-NB	Adaptive Multi-Rate Narrowband
AMR-WB	Adaptive Multi-Rate Wideband
ARP	Allocation Retention Priority
ASN	Abstract Syntax Notation
ASN.1	Abstract Syntax Notation One
ATM	Adaptive Transmission Bandwidth
AWGN	Additive White Gaussian Noise
AWGN	Additive White Gaussian Noise
BB	Baseband
BCCH	Broadcast Control Channel
BCH	Broadcast Channel
BE	Best Effort
BEM	Block Edge Mask
BICC	Bearer Independent Call Control Protocol
BiCMOS	Bipolar CMOS
BLER	Block Error Rate
BO	Backoff
BOM	Bill of Material
BPF	Band Pass Filter
BPSK	Binary Phase Shift Keying

BS	Base Station
BSC	Base Station Controller
BSR	Buffer Status Report
BT	Bluetooth
BTS	Base Station
BW	Bandwidth
CAZAC	Constant Amplitude Zero Autocorrelation Codes
CBR	Constant Bit Rate
CCE	Control Channel Element
CCCH	Common Control Channel
CDD	Cyclic Delay Diversity
CDF	Cumulative Density Function
CDM	Code Division Multiplexing
CDMA	Code Division Multiple Access
CIR	Carrier to Interference Ratio
CLM	Closed Loop Mode
CM	Cubic Metric
CMOS	Complementary Metal Oxide Semiconductor
CoMP	Coordinated Multiple Point
CP	Cyclic Prefix
CPE	Common Phase Error
CPICH	Common Pilot Channel
CQI	Channel Quality Information
CRC	Cyclic Redundancy Check
C-RNTI	Cell Radio Network Temporary Identifier
CS	Circuit Switched
CSCF	Call Session Control Function
CSFB	Circuit Switched Fallback
CSI	Channel State Information
CT	Core and Terminals
CTL	Control
CW	Continuous Wave
DAC	Digital to Analog Conversion
DARF	Downlink Advanced Receiver Performance
D-BCH	Dynamic Broadcast Channel
DC	Direct Current
DCCH	Dedicated Control Channel
DCH	Dedicated Channel
DC-HSDPA	Dual Cell (Dual Carrier) HSDPA
DCI	Downlink Control Information
DCR	Direct Conversion Receiver
DCXO	Digitally-Compensated Crystal Oscillator
DD	Duplex Distance
DFCA	Dynamic Frequency and Channel Allocation
DFT	Discrete Fourier Transform
DG	Duplex Gap
DL	Downlink

DL-SCH	Downlink Shared Channel
DPCCH	Dedicated Physical Control Channel
DR	Dynamic Range
DRX	Discontinuous Reception
DSP	Digital Signal Processing
DTCH	Dedicated Traffic Channel
DTM	Dual Transfer Mode
DTX	Discontinuous Transmission
DVB-H	Digital Video Broadcast – Handheld
DwPTS	Downlink Pilot Time Slot
E-DCH	Enhanced DCH
EDGE	Enhanced Data Rates for GSM Evolution
EFL	Effective Frequency Load
EFR	Enhanced Full Rate
EGPRS	Enhanced GPRS
E-HRDP	Evolved HRPD (High Rate Packet Data) network
EIRP	Equivalent Isotropic Radiated Power
EMI	Electromagnetic Interference
EPA	Extended Pedestrian A
EPC	Evolved Packet Core
EPDG	Evolved Packet Data Gateway
ETU	Extended Typical Urban
E-UTRA	Evolved Universal Terrestrial Radio Access
EVA	Extended Vehicular A
EVDO	Evolution Data Only
EVM	Error Vector Magnitude
EVS	Error Vector Spectrum
FACH	Forward Access Channel
FCC	Federal Communications Commission
FD	Frequency Domain
FDD	Frequency Division Duplex
FDE	Frequency Domain Equalizer
FDM	Frequency Division Multiplexing
FDPS	Frequency Domain Packet Scheduling
FE	Front End
FFT	Fast Fourier Transform
FM	Frequency Modulated
FNS	Frequency Non-Selective
FR	Full Rate
FRC	Fixed Reference Channel
FS	Frequency Selective
GB	Gigabyte
GBF	Guaranteed Bit Rate
GDD	Group Delay Distortion
GERAN	GSM/EDGE Radio Access Network
GF	G-Factor
GGSN	Gateway GPRS Support Node

GMSK	Gaussian Minimum Shift Keying
GP	Guard Period
GPON	Gigabit Passive Optical Network
GPRS	General packet radio service
GPS	Global Positioning System
GRE	Generic Routing Encapsulation
GSM	Global System for Mobile Communications
GTP	GPRS Tunneling Protocol
GTP-C	GPRS Tunneling Protocol, Control Plane
GUTI	Globally Unique Temporary Identity
GW	Gateway
HARQ	Hybrid Adaptive Repeat and Request
HB	High Band
HD-FDD	Half Duplex Frequency Division Duplex
HFN	Hyper Frame Number
HII	High Interference Indicator
HO	Handover
HPBW	Half Power Beam Width
HPF	High Pass Filter
HPSK	Hybrid Phase Shift Keying
HRPD	High Rate Packet Data
HS-DPA	High Speed Downlink Packet Access
HS-DSCH	High Speed Downlink Shared Channel
HSGW	HRPD Serving Gateway
HSPA	High Speed Packet Access
HS-PDSCH	High Speed Physical Downlink Shared Channel
HSS	Home Subscriber Server
HS-SCCH	High Speed Shared Control Channel
HSUPA	High Speed Uplink Packet Access
IC	Integrated Circuit
IC	Interference Cancellation
ICI	Inter-carrier Interference
ICIC	Inter-cell Interference Control
ICS	IMS Centralized Service
ID	Identity
IETF	Internet Engineering Task Force
IFFT	Inverse Fast Fourier Transform
IL	Insertion Loss
iLBC	Internet Low Bit Rate Codec
IM	Implementation Margin
IMD	Intermodulation
IMS	IP Multimedia Subsystem
IMT	International Mobile Telecommunications
IoT	Interference over Thermal
IOT	Inter-Operability Testing
IP	Internet Protocol
IR	Image Rejection

IRC	Interference Rejection Combining
ISD	Inter-site Distance
ISDN	Integrated Services Digital Network
ISI	Inter-system Interference
ISTO	Industry Standards and Technology Organization
ISUP	ISDN User Part
IWF	Interworking Function
LAI	Location Area Identity
LMA	Local Mobility Anchor
LB	Low Band
LCID	Logical Channel Identification
LCS	Location Services
LMMSE	Linear Minimum Mean Square Error
LNA	Low Noise Amplifier
LO	Local Oscillator
LOS	Line of Sight
LTE	Long Term Evolution
MAC	Medium Access Control
MAP	Maximum a Posteriori
MAP	Mobile Application Part
MBMS	Multimedia Broadcast Multicast System
MBR	Maximum Bit Rate
MCH	Multicast Channel
MCL	Minimum Coupling Loss
MCS	Modulation and Coding Scheme
MGW	Media Gateway
MIB	Master Information Block
MIMO	Multiple Input Multiple Output
MIP	Mobile IP
MIPI	Mobile Industry Processor Interface
MIPS	Million Instructions Per Second
MM	Mobility Management
MME	Mobility Management Entity
MMSE	Minimum Mean Square Error
MPR	Maximum Power Reduction
MRC	Maximal Ratio Combining
MSC	Mobile Switching Center
MSC-S	Mobile Switching Center Server
MSD	Maximum Sensitivity Degradation
MU	Multuser
NACC	Network Assisted Cell Change
NACK	Negative Acknowledgement
NAS	Non-access Stratum
NAT	Network Address Table
NB	Narrowband
NF	Noise Figure
NMO	Network Mode of Operation

NRT	Non-real Time
OFDM	Orthogonal Frequency Division Multiplexing
OFDMA	Orthogonal Frequency Division Multiple Access
OI	Overload Indicator
OLLA	Outer Loop Link Adaptation
OOB	Out of Band
OOBN	Out-of-Band Noise
O&M	Operation and Maintenance
PA	Power Amplifier
PAPR	Peak to Average Power Ratio
PAR	Peak-to-Average Ratio
PBR	Prioritized Bit Rate
PC	Personal Computer
PC	Power Control
PCC	Policy and Charging Control
PCCC	Parallel Concatenated Convolution Coding
PCCPCH	Primary Common Control Physical Channel
PCFICH	Physical Control Format Indicator Channel
PCH	Paging Channel
PCI	Physical Cell Identity
PCM	Pulse Code Modulation
PCRF	Policy and Charging Resource Function
PCS	Personal Communication Services
PDCCH	Physical Downlink Control Channel
PDCP	Packet Data Convergence Protocol
PDF	Probability Density Function
PDN	Packet Data Network
PDU	Payload Data Unit
PDSCH	Physical Downlink Shared Channel
PF	Proportional Fair
P-GW	Packet Data Network Gateway
PHICH	Physical HARQ Indicator Channel
PHR	Power Headroom Report
PHS	Personal Handyphone System
PHY	Physical Layer
PLL	Phase Locked Loop
PLMN	Public Land Mobile Network
PMI	Precoding Matrix Index
PMIP	Proxy Mobile IP
PN	Phase Noise
PRACH	Physical Random Access Channel
PRB	Physical Resource Block
PS	Packet Switched
PSD	Power Spectral Density
PSS	Primary Synchronization Signal
PUCCH	Physical Uplink Control Channel
PUSCH	Physical Uplink Shared Channel

QAM	Quadrature Amplitude Modulation
QCI	QoS Class Identifier
QD	Quasi Dynamic
QN	Quantization Noise
QoS	Quality of Service
QPSK	Quadrature Phase Shift Keying
RACH	Random Access Channel
RAD	Required Activity Detection
RAN	Radio Access Network
RAR	Random Access Response
RAT	Radio Access Technology
RB	Resource Block
RBG	Radio Bearer Group
RF	Radio Frequency
RI	Rank Indicator
RLC	Radio Link Control
RNC	Radio Network Controller
RNTP	Relative Narrowband Transmit Power
ROHC	Robust Header Compression
RR	Round Robin
RRC	Radio Resource Control
RRM	Radio Resource Management
RS	Reference Signal
RSCP	Received Symbol Code Power
RSRP	Reference Symbol Received Power
RSRQ	Reference Symbol Received Quality
RSSI	Received Signal Strength Indicator
RT	Real Time
RTT	Round Trip Time
RV	Redundancy Version
SA	Services and System Aspects
SAE	System Architecture Evolution
SAIC	Single Antenna Interference Cancellation
S-CCPCH	Secondary Common Control Physical Channel
SC-FDMA	Single Carrier Frequency Division Multiple Access
SCH	Synchronization Channel
SCM	Spatial Channel Model
SCTP	Stream Control Transmission Protocol
SDQNR	Signal to Distortion Quantization Noise Ratio
SDU	Service Data Unit
SE	Spectral Efficiency
SEM	Spectrum Emission Mask
SF	Spreading Factor
SFBC	Space Frequency Block Coding
SFN	System Frame Number
SGSN	Serving GPRS Support Node
S-GW	Serving Gateway

SIB	System Information Block
SID	Silence Indicator Frame
SIM	Subscriber Identity Module
SIMO	Single Input Multiple Output
SINR	Signal to Interference and Noise Ratio
SMS	Short Message Service
SNR	Signal to Noise Ratio
SON	Self Optimized Networks
SON	Self Organizing Networks
SR	Scheduling Request
S-RACH	Short Random Access Channel
SRB	Signaling Radio Bearer
S-RNC	Serving RNC
SRS	Sounding Reference Signals
SSS	Secondary Synchronization Signal
SR-VCC	Single Radio Voice Call Continuity
S-TMSI	S-Temporary Mobile Subscriber Identity
SU-MIMO	Single User Multiple Input Multiple Output
S1AP	S1 Application Protocol
TA	Tracking Area
TBS	Transport Block Size
TD	Time Domain
TDD	Time Division Duplex
TD-LTE	Time Division Long Term Evolution
TD-SCDMA	Time Division Synchronous Code Division Multiple Access
TM	Transparent Mode
TPC	Transmit Power Control
TRX	Transceiver
TSG	Technical Specification Group
TTI	Transmission Time Interval
TU	Typical Urban
UDP	Unit Data Protocol
UE	User Equipment
UHF	Ultra High Frequency
UICC	Universal Integrated Circuit Card
UL	Uplink
UL-SCH	Uplink Shared Channel
UM	Unacknowledged Mode
UMD	Unacknowledged Mode Data
UMTS	Universal Mobile Telecommunications System
UpPTS	Uplink Pilot Time Slot
USB	Universal Serial Bus
USIM	Universal Subscriber Identity Module
USSD	Unstructured Supplementary Service Data
UTRA	Universal Terrestrial Radio Access
UTRAN	Universal Terrestrial Radio Access Network
VCC	Voice Call Continuity

VCO	Voltage Controlled Oscillator
VDSL	Very High Data Rate Subscriber Line
VLR	Visitor Location Register
V-MIMO	Virtual MIMO
VoIP	Voice over IP
WCDMA	Wideband Code Division Multiple Access
WG	Working Group
WLAN	Wireless Local Area Network
WRC	World Radio Conference
X1AP	X1 Application Protocol
ZF	Zero Forcing

1

Introduction

Harri Holma and Antti Toskala

1.1 Mobile Voice Subscriber Growth

The number of mobile subscribers has increased tremendously during the last decade: the first billion landmark was exceeded in 2002, the second billion in 2005, the third billion in 2007 and the fourth billion by the end of 2008. More than 1 million new subscribers per day have been added globally, that is more than ten subscribers on average every second. This growth is illustrated in Figure 1.1. Mobile phone penetration worldwide is approaching

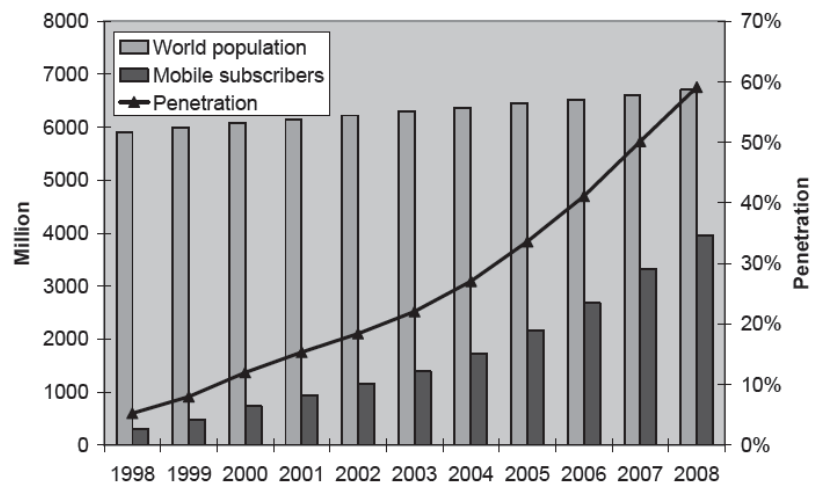

Figure 1.1 Growth of mobile subscribers

60%¹. Voice communication has become mobile in a massive way. The mobile is the preferred method for voice communication, with mobile networks covering over 90% of the world's population. This voice growth has been fuelled by low cost mobile phones and efficient network coverage and capacity, which is enabled by standardized solutions and by an open ecosystem leading to the economies of scale. Mobile voice is not the privilege of the rich but also brings value for users on low incomes – because of the benefits of being connected, low income users spend a larger part of their income on mobile communications.

1.2 Mobile Data Usage Growth

The second generation mobile networks – like Global System for Mobile Communications (GSM) – were originally designed for carrying voice traffic while the data capability was added later. Data usage has increased but the traffic volume in second generation networks is clearly dominated by voice traffic. The introduction of third generation networks with High Speed Downlink Packet Access (HSDPA) has boosted data usage considerably. Example operator statistics for 12 months are shown in Figure 1.2 where the HSDPA downlink data volumes are several terabytes per day, which correspond to beyond 1 Gbps busy hour network level throughput. Such fast data growth shows that the end users find value in the wireless broadband access.

Data traffic volume has in many cases already exceeded voice traffic volume when voice traffic is converted into terabytes by assuming a voice data rate of 12 kbps. A typical case is illustrated in Figure 1.3. HSDPA data growth is advanced by high speed radio capability, flat rate pricing schemes and simple device installation. In short, the introduction of HSDPA has changed mobile networks from voice dominated to packet data dominated networks.

Data usage is advanced by a number of bandwidth hungry laptop applications including internet and intranet access, file sharing, streaming services to distribute video content and mobile

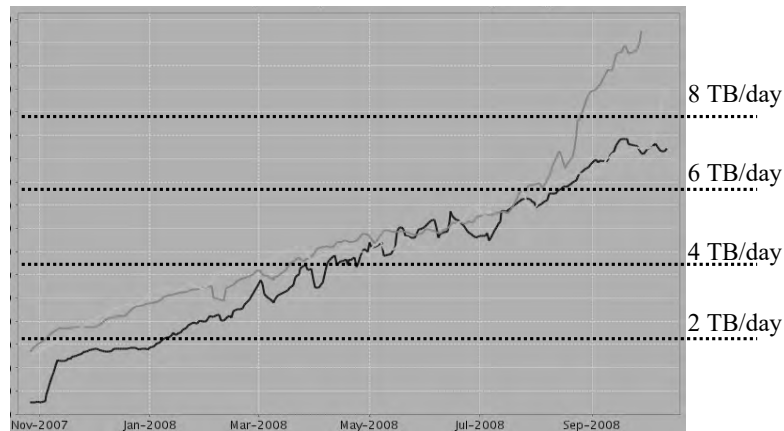

Figure 1.2 Growth of HSDPA data traffic

¹ The actual user penetration can be different since some users have multiple subscriptions and some subscriptions are shared by multiple users.

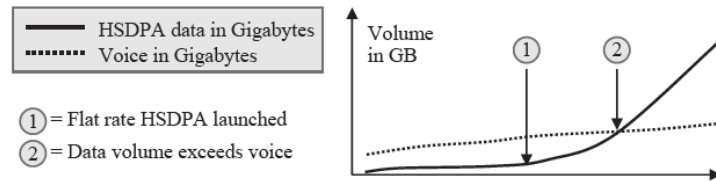

Figure 1.3 HSDPA data volume exceeds voice volume

TV and interactive gaming. In addition, service bundles of video, data and voice – known also as triple play – are entering the mobile market, also replacing the traditional fixed line voice and broadband data services with mobile services both at home and in the office.

A typical voice subscriber uses 300 minutes per month, which is equal to approximately 30 megabyte of data with a voice data rate of 12.2kbps. A broadband data user can easily consume more than 1000 megabyte (1 gigabyte) of data. Heavy broadband data usage takes 10–100× more capacity than voice usage, which sets high requirements for the capacity and efficiency of network data.

It is expected that by 2015, 5 billion people will be connected to the internet. Broadband internet connections will be available practically anywhere in the world. Already today, the existing wireline installations can reach approximately 1 billion households and the mobile networks connect over 3 billion subscribers. These installations need to evolve into broadband internet access. Further extensive use of wireless access as well as new wireline installations with enhanced capabilities are required to offer true broadband connectivity to the 5 billion customers.

1.3 Wireline Technologies Evolution

Although wide area wireless networks have experienced a fast evolution of data rates, wireline networks still provide the highest data rates. The evolution of the peak user data rate both in wireless and wireline networks is illustrated in Figure 1.4. Interestingly, the shape of the evolution curve is similar in both domains with a relative difference of approximately 30 times. An application of Moore's law predicts that data rates double every 18 months. Currently, copper based wireline solutions with Very High Data Rate Digital Subscriber Line (VDSL2) can offer bit rates of tens of Mbps and the passive optical fibre based solution gives rates in excess of 100Mbps. Both copper and fibre based solutions will have further data rate evolution in the near future, increasing the data rate offerings to the Gbps range.

Wireless networks must make data rates higher in order to match the user experience provided by wireline networks. When customers are used to wireline performance, they expect the wireless network to offer comparable performance. The applications designed for wireline networks advance the evolution of the wireless data rates.

Wireless technologies, on the other hand, have the huge benefit of being capable of offering personal broadband access independently of user location – in other words, mobility, for nomadic or full mobile use cases. A wireless solution can also provide low cost broadband coverage compared to new wireline installations if there is no existing wireline infrastructure. Therefore, wireless broadband access is an attractive option, especially in new growth markets in urban areas as well as in rural areas in other markets.

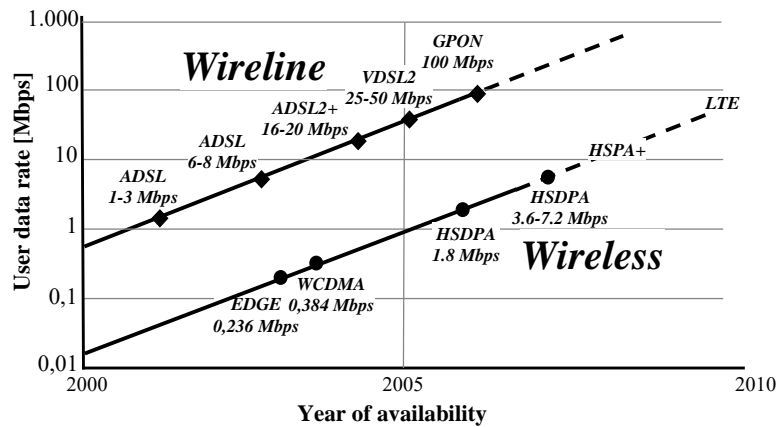

Figure 1.4 Evolution of wireless and wireline user data rates [Broadband Access for All - A Brief Technology Guide, Nokia Siemens Networks white paper (2007)]. GPON = Gigabit Passive Optical Network; VDSL = Very High Data Rate Subscriber Line; ADSL = Asymmetric Digital Subscriber Line

1.4 Motivation and Targets for LTE

The work towards 3rd Generation Partnership Project (3GPP) Long Term Evolution (LTE) started in 2004 with the definition of the targets. Even though HSDPA was not yet deployed at that time, it became evident that work for the next radio system should be started. It takes more than 5 years from setting the system targets to commercial deployment using interoperable standards. Therefore, system standardization must be started early enough to be ready by the time the need is there. A few driving forces can be identified advancing LTE development: wireline capability evolution, the need for additional wireless capacity, the need for lower cost wireless data delivery and the competition of other wireless technologies. As wireline technology keeps improving, a similar evolution is required in the wireless domain to make sure that the applications also work fluently in the wireless domain. There are also other wireless technologies – including IEEE 802.16 – which promise high data capabilities. 3GPP technologies must match and exceed the competition. More capacity is a clear requirement for taking maximum advantage of the available spectrum and base station sites. These reasons are summarized in Figure 1.5.

LTE must be able to deliver superior performance compared to existing 3GPP networks based on High Speed Packet Access (HSPA) technology. The performance targets in 3GPP are defined relative to HSPA in Release 6. The peak user throughput should be minimum 100Mbps in downlink and 50Mbps in uplink, which is ten times more than HSPA Release 6. Also the latency must be reduced in order to improve the end user performance. The terminal power consumption must be minimized to enable more usage of the multimedia applications without recharging the battery. The main performance targets are shown in Figure 1.6 and are listed below:

- spectral efficiency two to four times more than with HSPA Release 6;
- peak rates exceed 100Mbps in downlink and 50Mbps in uplink;

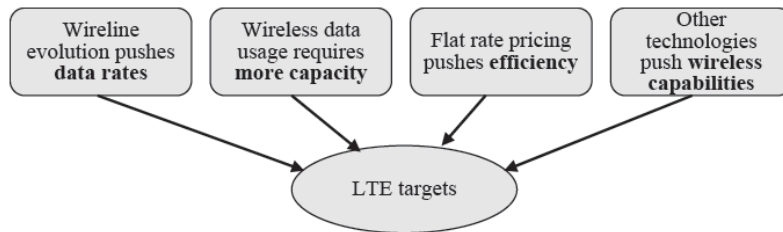

Figure 1.5 Driving forces for LTE development

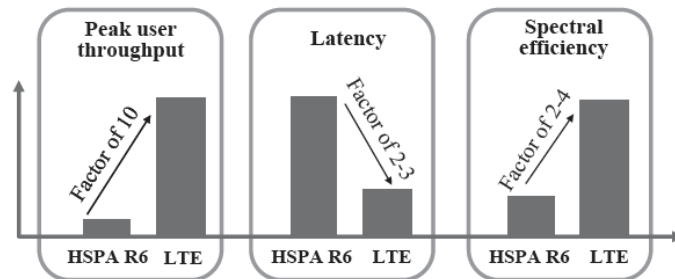

Figure 1.6 Main LTE performance targets

- enables round trip time <10ms;
- packet switched optimized;
- high level of mobility and security;
- optimized terminal power efficiency;
- frequency flexibility with from below 1.5MHz up to 20MHz allocations.

1.5 Overview of LTE

The multiple access scheme in LTE downlink uses Orthogonal Frequency Division Multiple Access (OFDMA) and uplink uses Single Carrier Frequency Division Multiple Access (SC-FDMA). These multiple access solutions provide orthogonality between the users, reducing the interference and improving the network capacity. The resource allocation in the frequency domain takes place with a resolution of 180kHz resource blocks both in uplink and in downlink. The frequency dimension in the packet scheduling is one reason for the high LTE capacity. The uplink user specific allocation is continuous to enable single carrier transmission while the downlink can use resource blocks freely from different parts of the spectrum. The uplink single carrier solution is also designed to allow efficient terminal power amplifier design, which is relevant for the terminal battery life. The LTE solution enables spectrum flexibility where the transmission bandwidth can be selected between 1.4MHz and 20MHz depending on the available spectrum. The 20MHz bandwidth can provide up to 150Mbps downlink user data rate with 2×2 MIMO, and 300Mbps with 4×4 MIMO. The uplink peak data rate is 75Mbps. The multiple access schemes are illustrated in Figure 1.7.

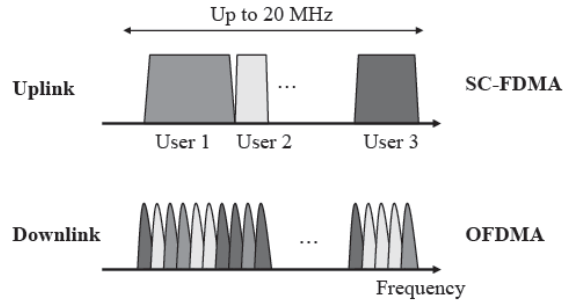

Figure 1.7 LTE multiple access schemes

The high network capacity also requires an efficient network architecture in addition to the advanced radio features. The target in 3GPP Release 8 is to improve the network scalability for traffic increase and to minimize the end-to-end latency by reducing the number of network elements. All radio protocols, mobility management, header compression and all packet retransmissions are located in the base stations called eNodeB. eNodeB includes all those algorithms that are located in Radio Network Controller (RNC) in 3GPP Release 6 architecture. Also the core network is streamlined by separating the user and the control planes. The Mobility Management Entity (MME) is just the control plane element while the user plane bypasses MME directly to System Architecture Evolution (SAE) Gateway (GW). The architecture evolution is illustrated in Figure 1.8. This Release 8 core network is also often referred to as Evolved Packet Core (EPC) while for the whole system the term Evolved Packet System (EPS) can also be used.

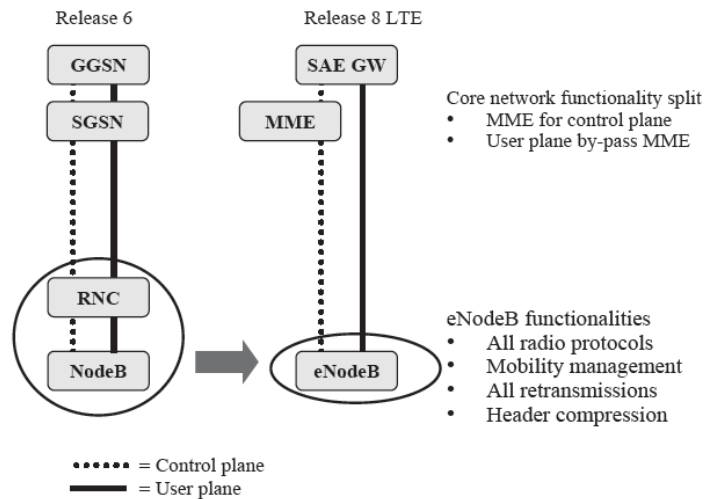

Figure 1.8 LTE network architecture

1.6 3GPP Family of Technologies

3GPP technologies – GSM/EDGE and Wideband Code Division Multiple Access (WCDMA)/HSPA – are currently serving nearly 90% of the global mobile subscribers. The market share development of 3GPP technologies is illustrated in Figure 1.9. A number of major Code Division Multiple Access (CDMA) operators have already turned or are soon turning to GSM/WCDMA for voice evolution and to HSPA/LTE for data evolution to get access to the benefits of the large and open 3GPP ecosystem and economics of scale for low cost mobile devices. The number of subscribers using 3GPP based technologies is currently more than 3.5 billion. The 3GPP LTE will be built on this large base of 3GPP technologies.

The time schedule of 3GPP specifications and the commercial deployments is illustrated in Figure 1.10. Enhanced Data rates for GSM Evolution (EDGE) was defined in 3GPP in 1997 and WCDMA at the end of 1999. Both systems had their first commercial deployments during

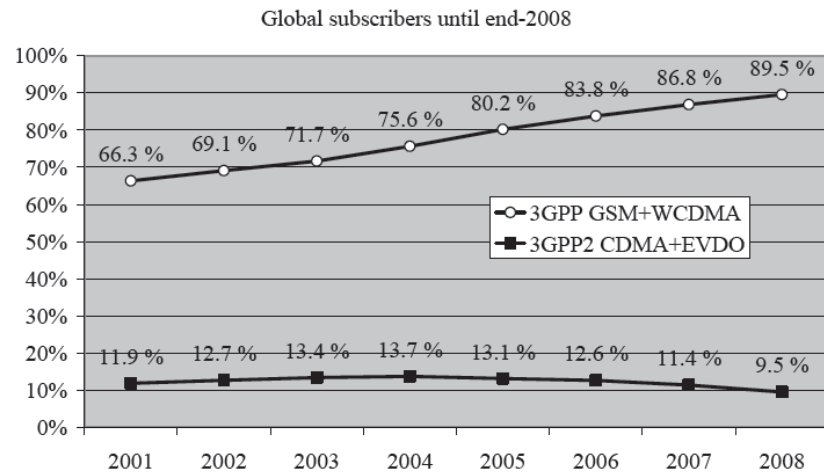

Figure 1.9 Global market share of 3GPP and 3GPP2 technologies. EVDO, evolution data only

3GPP schedule

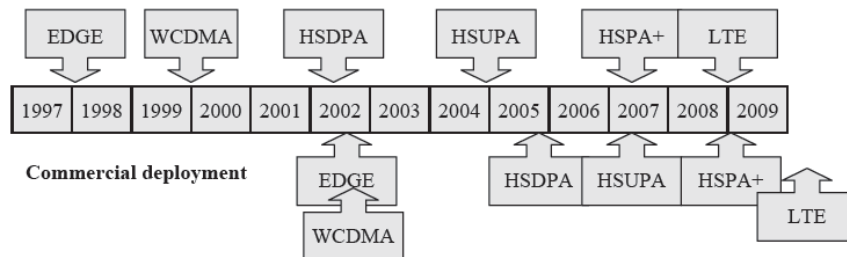

Figure 1.10 Schedule of 3GPP standard and their commercial deployments

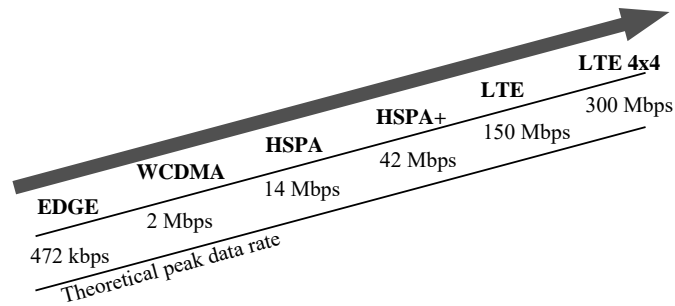

Figure 1.11 Peak data rate evolution of 3GPP technologies

2002. The HSDPA and High Speed Uplink Packet Access (HSUPA) standards were completed in March 2002 and December 2004, and the commercial deployments followed in 2005 and 2007. The first phase of HSPA evolution, also called HSPA+, was completed in June 2007 and the deployments start during 2009. The LTE standard was approved at the end of 2007, the backwards compatibility is expected to start in March 2009 and commercial deployments are expected in 2010.

The new generation of technologies pushes data rates higher. The evolution of the peak user data rates is illustrated in Figure 1.11. The first WCDMA deployments in 2002 offered 384 kbps, current HSDPA networks 7.2–14.4 Mbps, HSPA evolution 21–42 Mbps and LTE 2010 150 Mbps, that is a more than 300 times higher data rate over 8 years.

The 3GPP technologies are designed for smooth inter-working and coexistence. The LTE will support bi-directional handovers between LTE and GSM and between LTE and UMTS. GSM, UMTS and LTE can share a number of network elements including core network elements. It is also expected that some of the 3G network elements can be upgraded to support LTE and there will be single network platforms supporting both HSPA and LTE. The subscriber management and Subscriber Identity Module (SIM) based authentication will be used also in LTE; however, in LTE the system access requires the more modern and more secure Universal SIM (USIM) instead of the older 2G originated SIM card.

1.7 Wireless Spectrum

The LTE frequency bands in 3GPP specifications are shown in Figure 1.12 for paired bands and in Figure 1.13 for unpaired bands. There are 17 paired bands and 8 unpaired bands defined currently and more bands will be added during the standardization process. Some bands are currently used by other technologies and LTE can coexist with the legacy technologies. Similarly, in Europe and in Asia, WCDMA was initially deployed in the new 2100 MHz band while the refarming to the existing 900 MHz started during 2007. LTE will likely start by using the new 2600 MHz band and refarming to 900 and 1800 MHz bands. In the best case in Europe there is in total a 565 MHz spectrum available for the mobile operators when including 900 MHz, 1800 MHz, 2100 MHz Frequency Division Duplex (FDD) and Time Division Duplex (TDD) bands and the new 2600 MHz allocation all together.

Operating band	3GPP name	Total spectrum	Uplink [MHz]	Downlink [MHz]
Band 1	2100	2x60 MHz	1920-1980	2110-2170
Band 2	1900	2x60 MHz	1850-1910	1930-1990
Band 3	1800	2x75 MHz	1710-1785	1805-1880
Band 4	1700/2100	2x45 MHz	1710-1755	2110-2155
Band 5	850	2x25 MHz	824-849	869-894
Band 6	800	2x10 MHz	830-840	875-885
Band 7	2600	2x70 MHz	2500-2570	2620-2690
Band 8	900	2x35 MHz	880-915	925-960
Band 9	1700	2x35 MHz	1750-1785	1845-1880
Band 10	1700/2100	2x60 MHz	1710-1770	2110-2170
Band 11	1500	2x25 MHz	1427.9-1452.9	1475.9-1500.9
Band 12	US700	2x18 MHz	698-716	728-746
Band 13	US700	2x10 MHz	777-787	746-756
Band 14	US700	2x10 MHz	788-798	758-768
Band 17	US700	2x10 MHz	704-716	734-746
Band 18	Japan800	2x30 MHz	815-830	860-875
Band 19	Japan800	2x30 MHz	830-845	875-890

Figure 1.12 Frequency bands for paired bands in 3GPP specifications

Operating band	3GPP name	Total spectrum	Uplink and downlink [MHz]
Band 33	UMTS TDD1	1x20 MHz	1900-1920
Band 34	UMTS TDD2	1x15 MHz	2010-2025
Band 35	US1900 UL	1x60 MHz	1850-1910
Band 36	US1900 DL	1x60 MHz	1930-1990
Band 37	US1900	1x20 MHz	1910-1930
Band 38	2600	1x50 MHz	2570-2620
Band 39	UMTS TDD	1x40 MHz	1880-1920
Band 40	2300	1x50 MHz	2300-2400

Figure 1.13 Frequency bands for unpaired bands in 3GPP specifications

In the USA the WCDMA networks have been refarmed to 850 and 1900MHz. The new frequencies at 1700/2100 are also used for 3G deployment. LTE will be deployed using 700 and 1700/2100 bands, and later refarmed to the existing bands.

In Japan the LTE deployments start using the 2100 band followed later by 800, 1500 and 1700 bands.

Flexible bandwidth is desirable to take advantage of the diverse spectrum assets: refarming typically requires a narrowband option below 5MHz, while the new spectrum allocations could

take benefit of a wideband option up to 20MHz and higher data rates. It is also evident that both FDD and TDD modes are required to take full benefit of the available paired and unpaired spectrum. These requirements are taken into account in the LTE system specification.

1.8 New Spectrum Identified by WRC-07

The ITU-R World Radiocommunication Conference (WRC-07) worked in October and November 2007 to identify the new spectrum for International Mobile Telecommunications (IMT). The following bands were identified for IMT and are illustrated in Figure 1.14. The target was to identify both low bands for coverage and high bands for capacity.

The main additional coverage band will be in UHF frequencies 470–806MHz that are currently used for terrestrial TV broadcasting. The sub-band 790–862MHz was identified in Europe and Asia-Pacific. The availability of the band depends on the national time schedules of the analogue to digital TV switchover and it can become widely available within the 2012 to 2015 timeframe. The band allows, for example, three operators each running 10MHz LTE FDD.

The sub-band 698–806MHz was identified for IMT in the Americas. In the USA, part of the band has already been auctioned.

The main capacity band will be in 3.4–4.2GHz (C-band). Total 200MHz in the sub-band 3.4–3.8GHz was identified for IMT in Europe and in Asia-Pacific. This spectrum can facilitate the deployment of a larger bandwidth of IMT-Advanced to provide the highest bit rates and capacities.

Additionally, the band 2.3–2.4GHz was identified for IMT, but this band is not expected to be available in Europe or in the Americas. This band was already identified for IMT-2000 in China at the WRC-2000. The sub-band 450–470MHz was identified for IMT globally, but it is not expected to be widely available in Europe. This spectrum will be narrow with a maximum 2×5 MHz deployment.

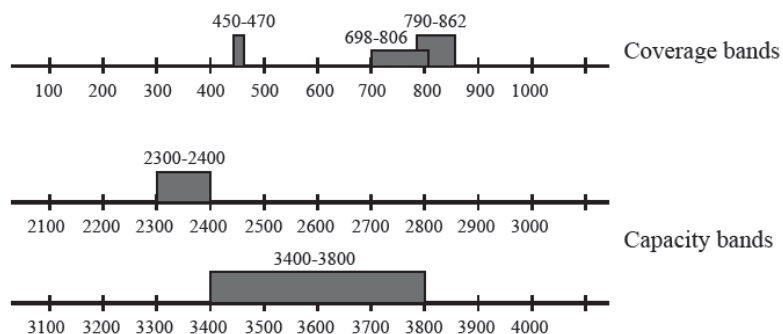

Figure 1.14 Main new frequencies identified for IMT in WRC-07

1.9 LTE-Advanced

International Mobile Telecommunications-Advanced (IMT-Advanced) is a concept for mobile systems with capabilities beyond IMT-2000. IMT-Advanced was previously known as Systems beyond IMT-2000. During 2009, there will be an open call for candidates for IMT-Advanced to be submitted to ITU, as well as the start of assessment activities of candidate technologies and systems. The radio interface submission deadline is expected by October 2009 and the final specifications by 2011.

The new capabilities of these IMT-Advanced systems are envisaged to handle a wide range of supported data rates according to economic and service demands in multi-user environments with target peak data rates of up to approximately 100Mbps for high mobility and up to 1 Gbps for low mobility such as nomadic/local wireless access. 3GPP has started to work towards IMT-Advanced targets also for the local area radio under the name LTE-Advanced. LTE-Advanced is planned to be part of 3GPP Release 10 and the commercial deployment of IMT-Advanced will be 2013 or later. The high level evolution of 3GPP technologies to meet IMT requirements is shown in Figure 1.15.

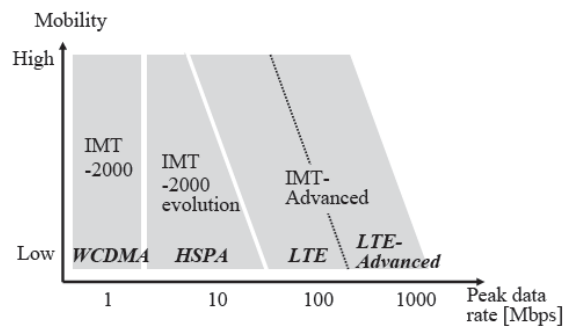

Figure 1.15 Bit rate and mobility evolution to IMT-Advanced

2

LTE Standardization

Antti Toskala

2.1 Introduction

Long Term Evolution (LTE) standardization is being carried out in the 3rd Generation Partnership Project (3GPP), as was also the case for Wideband CDMA (WCDMA), and the later phase of GSM evolution. This chapter introduces first the 3GPP LTE release schedule and the 3GPP standardization process. The requirements set for LTE by the 3GPP community are then reviewed, and the steps foreseen for later LTE Releases, including the LTE-Advanced work for the IMT-Advanced process, are covered. This chapter concludes with the introduction of LTE specifications and 3GPP structure.

2.2 Overview of 3GPP Releases and Process

The 3GPP has a background of 10 years for WCDMA development (or Universal Terrestrial Radio Access, UTRA) since the start of 3GPP in 1998. The major 3GPP releases are shown in Figure 2.1 starting from the first WCDMA release, Release 99, and covering the releases that followed. In Figure 2.1 the releases are shown with the date when the release content was finalized, not

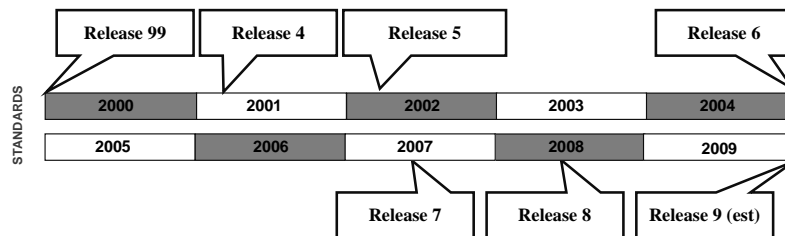

Figure 2.1 3GPP releases schedule with estimated Release 9 closure

the actual protocol freezing date (backwards compatibility start). The first WCDMA release – Release 99 – was published in December 1999 and contained the basic WCDMA features with theoretical data rates up to 2Mbps, based on the different multiple access for Frequency Division Duplex (FDD) mode and Time Division Duplex (TDD) operation. After that, 3GPP abandoned the yearly release principle and thus release naming was also changed as from Release 4, completed in March 2001. Release 4 did not have many major WCDMA features, but contained the new low chip rate TDD version (TD-SCDMA) for the TDD mode of UTRA. Release 5 followed with High Speed Downlink Packet Access (HSDPA) in March 2002 and Release 6 with High Speed Uplink Packet Access (HSUPA) in December 2004 for WCDMA. Release 7 was completed in June 2007 with the introduction of several HSDPA and HSUPA enhancements. Now 3GPP has just finalized Release 8 (with a few issues pending, for March 2009), which brought along further HSDPA/HSUPA improvements (often referred to jointly as High Speed Packet Access (HSPA) evolution) as well as containing the first LTE Release. The feature content for Release 8 was completed in December 2008. A more detailed description of the WCDMA/HSPA release content can be found in Chapter 13 covering Release 8 and in [1] for the earlier releases.

The earlier 3GPP Releases have a relationship to LTE in Release 8. Several of the novel features adopted – especially with HSDPA and HSUPA – are also used in LTE, such as base station based scheduling with physical layer feedback, physical layer retransmissions and link adaptation. Also, LTE specifications reuse the WCDMA design in areas where it could be carried out without compromising performance, thus facilitating reuse of the design and platforms developed for WCDMA. The first LTE release, Release 8, supports data rates up to 300Mbps in downlink and up to 75 Mbps in uplink with low latency and flat radio architecture. Release 8 also facilitates radio level inter-working with GSM, WCDMA and cdma2000®.

3GPP is introducing new work items and study items for Release 9, some of them related to features postponed from Release 8 and some of them for new topics raised for Release 9 with the topics introduced in December 2009. Release 9 is scheduled to be completed around the end of 2009. Release 10 is then foreseen to contain further radio capability enhancement in the form of LTE-Advanced, intended to be submitted to ITU-R IMT-Advanced process with data rate capabilities foreseen to range up to 1 Gbps. First Release 10 specifications are expected to be ready at the end of 2010.

The 3GPP process is such that more topics are started than eventually end up in the specifications. Often a study is initially carried out for more complicated issues, as was the case with LTE. Typically during a study, more alternatives are looked at than the small set of features that eventually enter a specification. Sometimes a study is completed with the finding that there is not enough gain to justify the added complexity in the system. A change requested in the work item phase could also be rejected for this same reason. The 3GPP process starting from a study item is shown in Figure 2.2.

2.3 LTE Targets

At the start of the work during the first half 2005, the 3GPP defined the requirements for LTE development. The key elements included in the target setting for the LTE feasibility study work, as defined in [2], were as follows:

- The LTE system should be packet switched domain optimized. This means that circuit switched elements are not really considered, but everything is assumed to be based on a

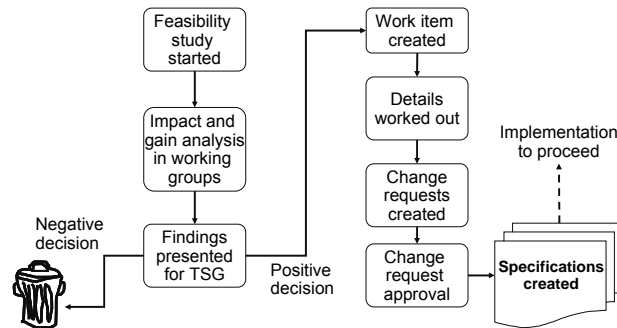

Figure 2.2. 3GPP process for moving from study towards work item and specification creation

packet type of operation. The system was required to support IP Multimedia Sub-system (IMS) and further evolved 3GPP packet core.

- As the data rates increase, latency needs to come down for the data rates to show any practical improvement. Thus the requirement for the LTE radio round trip time was set to be below 10 ms and access delay below 300 ms.
- The requirements for the data rates were defined to ensure sufficient steps in terms of data rates in contrast to HSPA. The peak rate requirements for uplink and downlink were set at 50Mbps and 100Mbps respectively.
- As the 3GPP community was used to a good level of security and mobility with the earlier systems – starting from GSM – it was also a natural requirement that these should be sustained. This also included inter-system mobility with GSM and WCDMA, as well as cdma2000®, since there was (and is) a major interest in the cdma2000® community to evolve to LTE for next generation networks.
- With WCDMA, one of the topics that had caused challenges – especially in the beginning – was terminal power consumption, thus it was required to improve terminal power efficiency.
- In the 3GPP technology family there were both a narrowband system (GSM with 200 kHz) and a wideband system (WCDMA with 5 MHz). Thus it was now required that the new system facilitate frequency allocation flexibility with 1.25/2.5, 5, 10, 15 and 20 MHz allocations. Later during the course of work, the actual bandwidth values were slightly adjusted for the two smallest bandwidths (to use 1.4 and 3 MHz bandwidths) to give a good match for both GSM and cdma2000® refarming cases. The possibility of using LTE in a deployment with WCDMA or GSM as the system on the adjacent band was also required.
- The ‘standard’ requirement for any new system is also to have higher capacity. The benchmark level chosen was 3GPP Release 6, which had a stable specification and a known performance at the time. Thus Release 6 was a stable comparison level for running the LTE performance simulations during the feasibility study phase. Depending on the case, 2- to 4-times higher capacity than provided with the Release 6 HSDPA/HSUPA reference case, was required.
- One of the drivers for the work was cost, to ensure that the new system could facilitate lower investment and operating costs compared to the earlier system. This was a natural result of the flat rate charging model appearing at the time for data use and created pressure for the price vs data volume level.

It was also expected that further development of WCDMA would continue in parallel with the LTE activity, and this has been also carried out with the Release 8 HSPA improvements, as covered in Chapter 13.

2.4 LTE Standardization Phases

LTE work was started as a study in the 3GPP, with the first workshop held in November 2004 in Canada. In the workshop the first presentations were on both the expected requirements for the work and the expected technologies to be adopted. Contributions were made from both operator and vendor viewpoints.

Following the workshop, 3GPP TSG RAN approved the start of the study for LTE in December 2004, with the work first running in the RAN plenary level to define the requirements and then moving to the working groups for detailed technical discussions for multiple access, protocol solutions and architecture. The first key issues to be resolved were what the requirements are, as discussed in section 2.3, and these were mainly settled during the first half of 2005, visible in [2], with the first approved version in June 2005. Then the work focused on solving two key questions:

- What should be the LTE radio technology in terms of multiple access?
- What should be the system architecture?

The multiple access discussion was soon concluded with the finding that something new was needed instead of just extending WCDMA. This conclusion was the result of the large range of requirements for covering different bandwidths and data rates with reasonable complexity. The use of Orthogonal Frequency Division Multiple Access (OFDMA) in the downlink was obvious early on, and had already been reflected in many of the presentations in the original LTE workshop in 2004. For the uplink multiple access, the Single Carrier Frequency Division Multiple Access (SC-FDMA) soon emerged as the most favourable choice that was supported by many key vendors and operators, as could be seen, for example, in [3]. A noticeable improvement from the WCDMA was that both FDD and TDD modes had the same multiple access solution, as addressed for the FDD and TDD differences in Chapter 12. The OFDMA and SC-FDMA principles and motivational aspects are further covered in Chapter 4. The multiple access decision was officially endorsed at the end of 2005 and after that the LTE radio work focused on the chosen technologies. The LTE milestones are shown in Figure 2.3. The FDD/TDD alignment refers to the agreement on

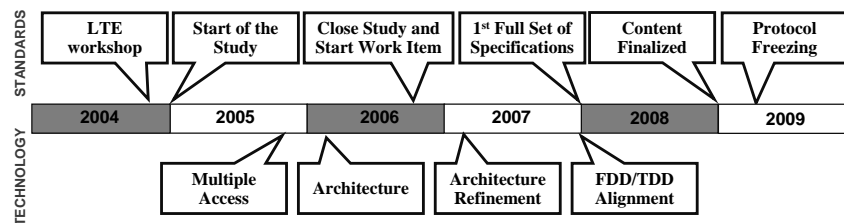

Figure 2.3 LTE milestones in 3GPP

the adjustment of the frame structure to minimize the differences between FDD and TDD modes of operation.

In the area of LTE architecture, after some debate it was decided to aim for a single node RAN, resulting in all radio related functionality being placed in the base station. This time the term used in 3GPP became eNodeB, with ‘e’ standing for evolved. The original architecture split, as shown in Figure 2.4, was endorsed in March 2006 with a slight adjustment carried out in early 2007 (with the Packet Data Convergence Protocol (PDCP) shifted from core network side to eNodeB). The fundamental difference to the WCDMA network was the lack of the Radio Network Controller (RNC) type of an element. The architecture is further described in Chapter 3.

The study also evaluated the resulting LTE capacity, and the studies reported in [4] and further refined studies summarized in [5] show that the requirements could be reached.

The study item was closed formally in September 2006 and detailed work items started to make the LTE part of the 3GPP Release 8 specifications.

The LTE specification work produced the first set of approved physical layer specifications in September 2007 and the first full set of approved LTE specifications in December 2007. Clearly there were open issues in the specifications at that time, especially in the protocol specifications and in the area of performance requirements. The remaining specification freezing process could be divided into three different steps:

- 1 Freezing the functional content of the LTE specifications in terms of what will be finalized in Release 8. This has meant leaving out some of the originally planned functionality such as support for broadcast use (point to multipoint data broadcasting). Functional freeze thus means that no new functionality can be introduced anymore but the agreed content will be finalized. In LTE the introduction of new functionality was basically over after June 2008 and during the rest of 2008 the work focused on completing the missing pieces (and correcting detected errors), especially in the protocol specifications, mainly completed for December 2008.

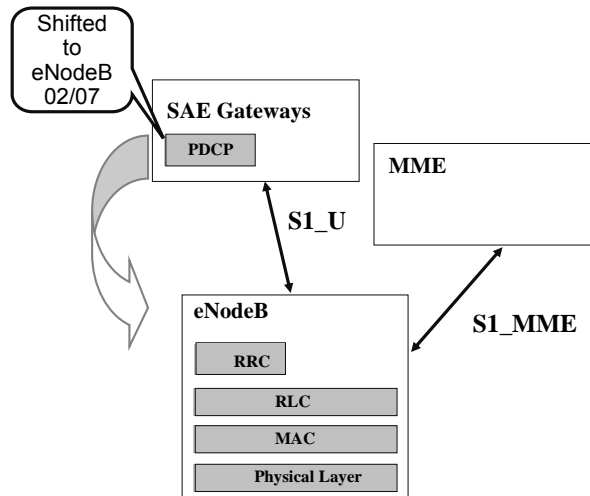

Figure 2.4 Original network architecture for LTE radio protocols

- 2 Once all the content is ready, the next step is to freeze the protocol specifications in terms of starting backwards compatibility. Backwards compatibility defines for a protocol the first version which can be the commercial implementation baseline. Until backwards compatibility is started, the protocol specifications are corrected by deleting any information elements that are not working as intended and replacing them with new ones. Once the start of backwards compatibility is reached, older information elements are no longer removed but extensions are used. This allows the equipment based on the older version to work based on the old information elements (though not necessarily 100% optimally), while equipment with newer software can read the improved/corrected information element after noticing the extension bit being set. Obviously, core functionality needs to work properly so that the start of backwards compatibility makes sense, as if something is totally wrong, fixing it with backwards compatible correction does not help older software versions if there is no operational functionality. It is planned to reach this step with 3GPP Release 8 protocol specifications in March 2009 when the protocol language, Abstract Syntax Notation One (ASN.1), related review for debugging all the errors is completed. With Release 7 specifications (containing HSPA improvements) this phase was reached in December 2007 following the content completion in June 2007.
- 3 The last phase is 'deep' freeze of the specifications, when any changes to the specifications will no longer be allowed. This is something that is valid for a release that is already rolled out in the field, such as Release 5 with HSDPA and Release 6 with HSUPA. With the devices out in the field, core functionality has been proven and tested and there is no point in any further changes to those releases, but potential improvement would need to be carried out in a later release. This kind of problem may arise when some feature has not been implemented (and thus no testing with the network has been possible) and the problem is only detected later. Then the resulting outcome could be to correct it in a later release and also recommend that the network activates it only for devices which are based on this later release. For LTE specifications, this phase is expected to be just before the actual roll-out, in a 2010 time frame, as typically some errors are detected in the implementation and trialling phase.

2.5 Evolution Beyond Release 8

The work in 3GPP during 2008 focused on Release 8 finalization, but work was started for issues beyond Release 8, including the first Release 9 topics as well as LTE-Advanced for IMT-Advanced. The following topics have been decided in 3GPP to be considered beyond Release 8:

- LTE MBMS, which is expected to cover the operation of broadcast type data both for a dedicated MBMS carrier and for a shared carrier. When synchronized properly, an OFDMA based broadcast signal can be sent in the same resource space from different base stations (with identical content) and then the signal from multiple base stations can be combined in the devices. This principle is already in use in, for example, Digital Video Broadcasting for Handhelds (DVB-H) devices in the market. DVB-H is also an OFDMA based system but only intended for broadcast use.
- Self Optimized Networks (SON) enhancements. 3GPP has worked on the self optimization/configuration aspects of LTE and that work is expected to continue in Release 9.
- Further improvements for enhanced VoIP support in LTE. In the discussions in 3GPP, it has been identified that VoIP could be further optimized to improve the maximum number

of VoIP users that could be supported simultaneously. The current capability is rather high already, as shown in Chapter 10.

- The requirements for the multi-bandwidth and multi-radio access technology base stations. The scope of this work is to define the requirements for the operation so that the same Radio Frequency (RF) part is used for transmitting, for example, LTE and GSM or LTE and WCDMA signals. Currently the requirements for the emissions on the adjacent frequencies, for example, take only a single Radio Access Technology (RAT) into account, while the requirements will now be developed for different combinations, including running multiple LTE bandwidths in parallel in addition to the multi-RAT case.

2.6 LTE-Advanced for IMT-Advanced

In parallel to the work for LTE corrections and further optimization in Release 9, the 3GPP is also targeting the creation of the input for the IMT-Advanced process in ITU-R. The ITU-R is developing the framework for next generation wireless networks. The following are the requirements from the ITU-R side for the IMT-Advanced candidate technologies, as reflected in details in the information available from ITU-R, accessible via the links given in [6]:

- support for peak data rates up to 1 Gbps for nomadic (low mobility case) and 100 Mbps for the high mobility case;
- support for larger bandwidths, and thus also 3GPP is considering specifying up to 100 MHz bandwidth support for LTE-Advanced;
- requirements for the expected spectral efficiency in different environments. In ITU-R requirements these are defined as minimum requirements and are thus different from the target type of value setting in 3GPP.

3GPP thus also has its own requirements, with the first version of the requirements approved in May 2008 as reflected in [7]. One of the 3GPP specific requirements is the backwards compatibility from the 3GPP Release 8 LTE. The requirement is defined so that a Release 8 based LTE device can operate in the LTE-Advanced system and, respectively, the Release 10 LTE Advanced device can access the Release 8 LTE networks. Obviously a Release 9 terminal would also be similarly accommodated. This could be covered, for example, with the multicarrier type of alternative as shown in Figure 2.5. The mobility between LTE-Advanced needs to work with LTE as well as GSM/EDGE, HSPA and cdma2000®.

The ITU-R process, as shown in Figure 2.6, aims for early 2011 completion of the ITU-R specifications, which requires 3GPP to submit the first full set of specifications around the end of 2010. This is one of the factors shaping the Release 10 finalization schedule, though officially the Release 10 schedule has not yet been defined in 3GPP, but will be discussed further once Release 9 work has progressed further.

3GPP has held a number of discussions on LTE-Advanced during 2008, and the technologies to be investigated include:

- Relay nodes. These are targeted for extending coverage by allowing User Equipment (UE) further away from the base station to send their data via relay nodes that can hear the eNodeB better than, for example, UE located indoors.

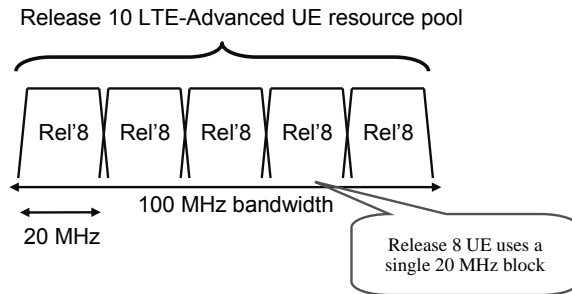

Figure 2.5 Resource sharing between LTE and LTE-Advanced

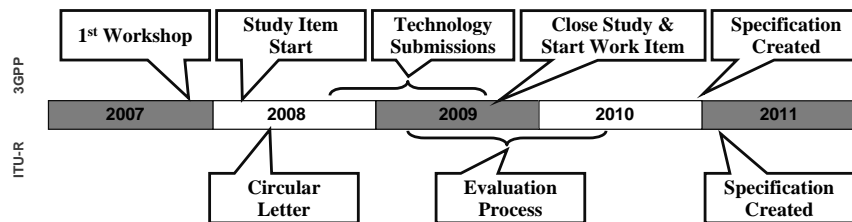

Figure 2.6 3GPP LTE-Advanced and ITU-R IMT-Advanced schedules

- UE dual transmit antenna solutions for uplink Single User MIMO (SU-MIMO) and diversity MIMO.
- Scalable system bandwidth exceeding 20MHz, potentially up to 100MHz. In connection with this the study has been investigating aspects related to multiple access technology with up to 100MHz system bandwidth, and it is foreseen to be based strongly on the existing LTE solutions with extensions to larger bandwidths. How to extend the bandwidth (and how that is reflected in the multiple access) is the first topic where conclusions are expected in LTE-Advanced studies.
- Nomadic/Local Area network and mobility solutions.
- Flexible Spectrum Usage.
- Automatic and autonomous network configuration and operation.
- Coordinated Multiple Point (CoMP) transmission and reception, which is referring to MIMO transmission coordinated between different transmitters (in different sectors or even different sites in an extreme case).

It is worth noting that even though some technology is being studied, it does not necessarily mean that it will be included in the Release 10 specifications. It may be decided that some issues are already needed for Release 9 (scheduled for the end of 2009), while other issues may not be necessary at all due to low gain and/or high complexity. The 3GPP study will be completed in the second half of 2009 and then work towards the actual specifications of Release 10 will start. Some of the items from the LTE-Advanced studies are also expected to be postponed to beyond Release 10.

The process in ITU-R is open for other RAT submissions as well. Similarly, as was the case in the original IMT-2000 process, multiple RAT submissions are expected to be made available for the evaluation phase. Assuming those submissions can meet the IMT-Advanced minimum requirements, the RATs submitted are then expected to be part of the IMT-Advanced family.

2.7 LTE Specifications and 3GPP Structure

The LTE specifications mostly follow similar notation to that of the WCDMA specifications, just using the 36-series numbering. For example, when WCDMA RRC is 25.331, the corresponding LTE spec is 36.331. The LTE specifications use the term Evolved Universal Terrestrial Radio Access (E-UTRA) while the WCDMA specifications use the UTRA term (and UTRAN with N standing for Network). The terms LTE and E-UTRAN, as well as WCDMA and UTRA, are used interchangeably in the book. In the physical layer there are some differences, e.g. the specification on spreading and modulation was not needed, such as WCDMA specification 25.213. Now due to use of the same multiple access, the FDD and TDD modes are covered in the same physical layer specification series. In Figure 2.7 the specification numbers are shown for the physical layer and different protocols over the radio or internal interfaces. Note that not all the performance related specifications are shown. The following chapters will introduce the functionality in each of the interfaces shown in Figure 2.7. All the specifications listed are available from the 3GPP website [8]. When using a 3GPP specification it is always recommended that the latest version of the release in question is used. For example, version 8.0.0 is always the first approved version and versions with the number 8.4.0 (or higher) are normally more stable with fewer errors.

Inside 3GPP, the 3GPP TSG RAN is responsible for LTE specification development. The detailed specification work is covered in the Working Groups (WGs) under each TSG. TSG RAN has a total of five working groups, as shown in Figure 2.8, where working groups under other TSGs are not shown. The specifications for the Evolved Packet Core (EPC) are covered in TSA SA and in TSG CT and are also needed for an end-to-end functioning system. The TSG GERAN is responsible for the necessary Release 8 changes in GSM/EDGE specifications to facilitate the LTE-GERAN inter-working from the GERAN perspective.

From the RAN working groups the physical layer specifications 36.2 series are developed by WG1, as shown in Figure 2.8. Respectively, the Layer 2 (L2) and Layer 3 (L3) specifica-

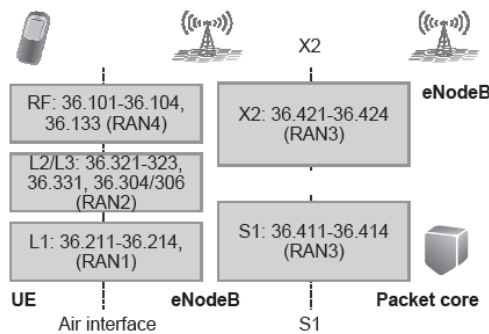

Figure 2.7. Specifications with responsible working groups for different LTE interfaces

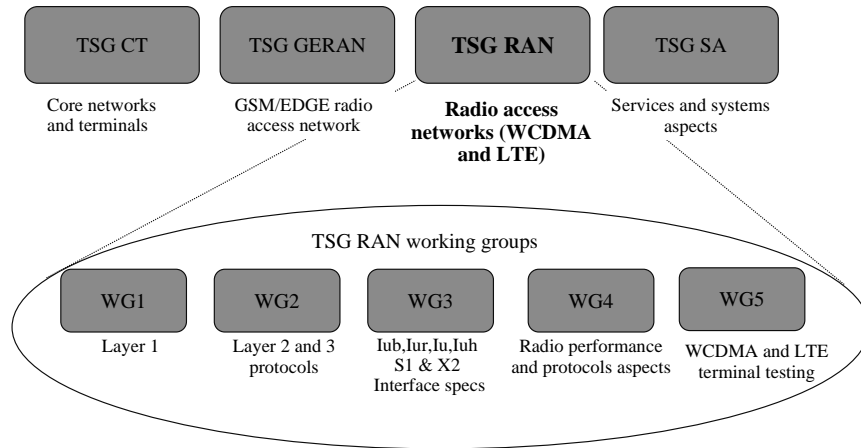

Figure 2.8 3GPP structure

tions are in the 36.3 series from WG2, internal interfaces in the 36.4 series from WG3, and radio performance requirements in the 36.1 series from WG4. Outside Figure 2.7 can be noted the LTE terminal test specifications from WG5. All groups cover the respective areas also for WCDMA/HSPA further releases as well.

References

- [1] H.Holma, A.Toskala, 'WCDMA for UMTS', 4th edition, Wiley 2007.
- [2] 3GPP Technical Report, TR 25.913, 'Requirements for Evolved UTRA (E-UTRA) and Evolved UTRAN (E-UTRAN)' version 7.0.0, June 2005.
- [3] 3GPP Tdoc, RP-050758, LS on UTRAN LTE Multiple Access Selection, 3GPP TSG RAN WG1, November 2005.
- [4] 3GPP Technical Report, TR 25.814, 'Physical layer aspects for evolved Universal Terrestrial Radio Access (UTRA)', 3GPP TSG RAN, September 2006.
- [5] 3GPP Tdoc, RP-060535, LS on LTE SI Conclusions, 3GPP TSG RAN WG1, September 2006.
- [6] 3GPP Tdoc, RP-080448, 'Receipt of ITU-R Circular Letter 5/LCCE/2 on IMT-Advanced', May 2008.
- [7] 3GPP Technical Report, TR 36.913, 'Requirements for Further Advancements for E-UTRA (LTE-Advanced)', 3GPP TSG RAN, version 8.0.0, May 2008.
- [8] www.3gpp.org

3

System Architecture Based on 3GPP SAE

Atte Lämsä and Antti Toskala

3.1 System Architecture Evolution in 3GPP

When the evolution of the radio interface started, it soon became clear that the system architecture would also need to be evolved. The general drive towards optimizing the system only for packet switched services is one reason that alone would have set the need for evolution, but some of the radio interface design goals – such as removal of soft handover – opened up new opportunities in the architecture design. Also, since it had been shown by High Speed Packet Access (HSPA) that all radio functionality can be efficiently co-located in the NodeB, the door was left open for discussions of flatter overall architecture.

Discussions for System Architecture Evolution (SAE) then soon followed the radio interface development, and it was agreed to schedule the completion of the work in Release 8. There had been several reasons for starting this work, and there were also many targets. The following lists some of the targets that possibly shaped the outcome the most:

- optimization for packet switched services in general, when there is no longer a need to support the circuit switched mode of operation;
- optimized support for higher throughput required for higher end user bit rates;
- improvement in the response times for activation and bearer set-up;
- improvement in the packet delivery delays;
- overall simplification of the system compared to the existing 3GPP and other cellular systems;
- optimized inter-working with other 3GPP access networks;
- optimized inter-working with other wireless access networks.

Many of the targets implied that a flat architecture would need to be developed. Flat architecture with less involved nodes reduces latencies and improves performance. Development

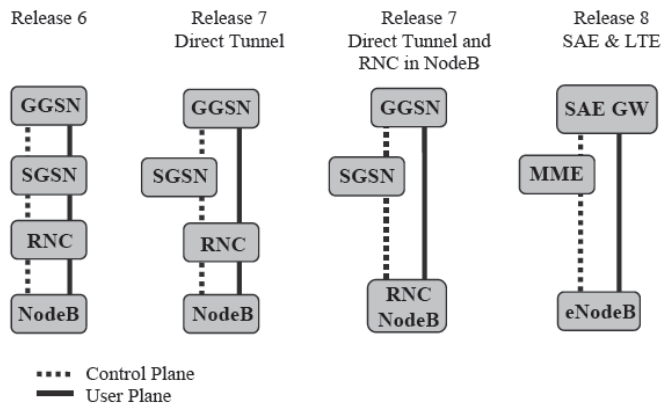

Figure 3.1 3GPP architecture evolution towards flat architecture

towards this direction had already started in Release 7 where the Direct Tunnel concept allows User Plane (UP) to bypass the SGSN, and the placement of RNC functions to HSPA NodeB was made possible. Figure 3.1 shows these evolution steps and how this aspect was captured at a high level in SAE architecture.

Some of the targets seem to drive the architecture development in completely different directions. For example, optimized inter-working with several wireless access networks (ANs) indicates the need to introduce a set of new functions and maybe even new interfaces to support specific protocols separately for each one of them. This works against the target of keeping the architecture simple. Therefore, since it is likely that that none of the actual deployments of the architecture would need to support all of the potential inter-working scenarios, the 3GPP architecture specifications were split into two tracks:

- GPRS enhancements for E-UTRAN access [1]: This document describes the architecture and its functions in its native 3GPP environment with E-UTRAN and all the other 3GPP ANs, and defines the inter-working procedures between them. The common nominator for these ANs is the use of GTP (GPRS Tunnelling Protocol) as the network mobility protocol.
- Architecture enhancements for non-3GPP accesses [2]: This document describes the architecture and functions when inter-working with non-3GPP ANs, such as cdma2000® High Rate Packet Data (HRPD), is needed. The mobility functionality in this document is based on IETF protocols, such as MIP (Mobile Internet Protocol) and PMIP (Proxy MIP), and the document also describes E-UTRAN in that protocol environment.

This chapter further describes the 3GPP system architecture in some likely deployment scenarios: basic scenario with only E-UTRAN, legacy 3GPP operator scenario with existing 3GPP ANs and E-UTRAN, and finally E-UTRAN with non-3GPP ANs, where inter-working with cdma2000® is shown as a specific example.

3.2 Basic System Architecture Configuration with only E-UTRAN Access Network

3.2.1 Overview of Basic System Architecture Configuration

Figure 3.2 describes the architecture and network elements in the architecture configuration where only the E-UTRAN AN is involved. The logical nodes and connections shown in this figure represent the basic system architecture configuration. These elements and functions are needed in all cases when E-UTRAN is involved. The other system architecture configurations described in the next sections also include some additional functions.

This figure also shows the division of the architecture into four main high level domains: User Equipment (UE), Evolved UTRAN (E-UTRAN), Evolved Packet Core Network (EPC), and the Services domain.

The high level architectural domains are functionally equivalent to those in the existing 3GPP systems. The new architectural development is limited to Radio Access and Core Networks, the E-UTRAN and the EPC respectively. UE and Services domains remain architecturally intact, but functional evolution has also continued in those areas.

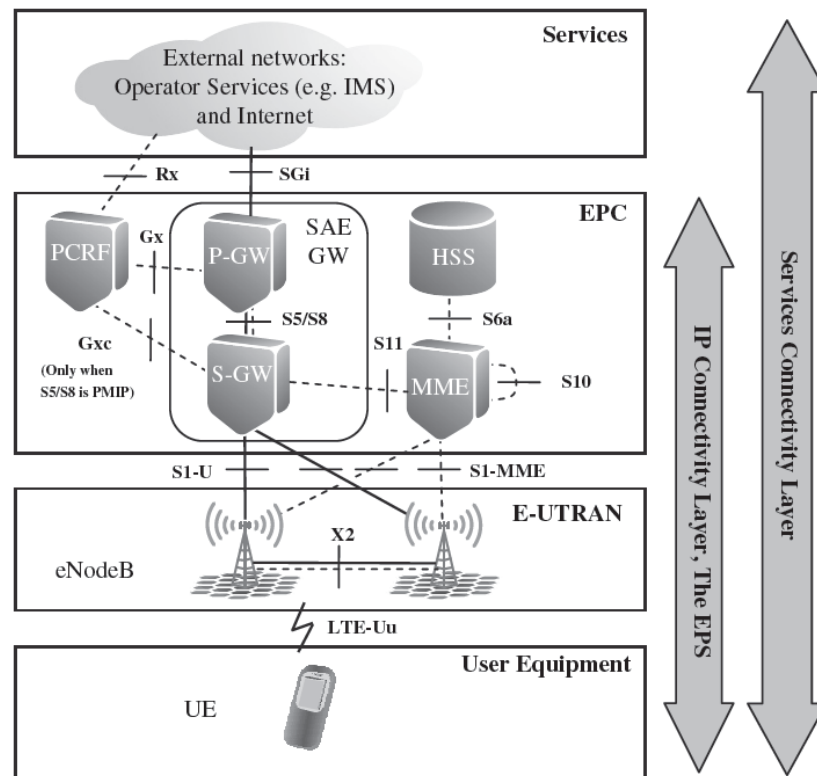

Figure 3.2 System architecture for E-UTRAN only network

UE, E-UTRAN and EPC together represent the Internet Protocol (IP) Connectivity Layer. This part of the system is also called the Evolved Packet System (EPS). The main function of this layer is to provide IP based connectivity, and it is highly optimized for that purpose only. All services will be offered on top of IP, and circuit switched nodes and interfaces seen in earlier 3GPP architectures are not present in E-UTRAN and EPC at all. IP technologies are also dominant in the transport, where everything is designed to be operated on top of IP transport.

The IP Multimedia Sub-System (IMS) [3] is a good example of service machinery that can be used in the Services Connectivity Layer to provide services on top of the IP connectivity provided by the lower layers. For example, to support the voice service, IMS can provide Voice over IP (VoIP) and interconnectivity to legacy circuit switched networks PSTN and ISDN through Media Gateways it controls.

The development in E-UTRAN is concentrated on one node, the evolved Node B (eNodeB). All radio functionality is collapsed there, i.e. the eNodeB is the termination point for all radio related protocols. As a network, E-UTRAN is simply a mesh of eNodeBs connected to neighbouring eNodeBs with the X2 interface.

One of the big architectural changes in the core network area is that the EPC does not contain a circuit switched domain, and no direct connectivity to traditional circuit switched networks such as ISDN or PSTN is needed in this layer. Functionally the EPC is equivalent to the packet switched domain of the existing 3GPP networks. There are, however, significant changes in the arrangement of functions and most nodes and the architecture in this part should be considered to be completely new.

Both Figure 3.1 and Figure 3.2 show an element called SAE GW. As the latter figure indicates, this represents the combination of the two gateways, Serving Gateway (S-GW) and Packet Data Network Gateway (P-GW) defined for the UP handling in EPC. Implementing them together as the SAE GW represents one possible deployment scenario, but the standards define the interface between them, and all operations have also been specified for when they are separate. The same approach is followed in this chapter of the book.

The Basic System Architecture Configuration and its functionality are documented in 3GPP TS 23.401 [1]. This document shows the operation when the S5/S8 interface uses the GTP protocol. However, when the S5/S8 interface uses PMIP, the functionality for these interfaces is slightly different, and the Gxc interface also is needed between the Policy and Charging Resource Function (PCRF) and S-GW. The appropriate places are clearly marked in [1] and the additional functions are described in detail in 3GPP TS 23.402 [2]. In the following sections the functions are described together for all cases that involve E-UTRAN.

3.2.2 Logical Elements in Basic System Architecture Configuration

This section introduces the logical network elements for the Basic System Architecture configuration.

3.2.2.1 User Equipment (UE)

UE is the device that the end user uses for communication. Typically it is a hand held device such as a smart phone or a data card such as those used currently in 2G and 3G, or it could be embedded, e.g. to a laptop. UE also contains the Universal Subscriber Identity Module (USIM)

that is a separate module from the rest of the UE, which is often called the Terminal Equipment (TE). USIM is an application placed into a removable smart card called the Universal Integrated Circuit Card (UICC). USIM is used to identify and authenticate the user and to derive security keys for protecting the radio interface transmission.

Functionally the UE is a platform for communication applications, which signal with the network for setting up, maintaining and removing the communication links the end user needs. This includes mobility management functions such as handovers and reporting the terminals location, and in these the UE performs as instructed by the network. Maybe most importantly, the UE provides the user interface to the end user so that applications such as a VoIP client can be used to set up a voice call.

3.2.2.2 E-UTRAN Node B (eNodeB)

The only node in the E-UTRAN is the E-UTRAN Node B (eNodeB). Simply put, the eNodeB is a radio base station that is in control of all radio related functions in the fixed part of the system. Base stations such as eNodeB are typically distributed throughout the networks coverage area, each eNodeB residing near the actual radio antennas.

Functionally eNodeB acts as a layer 2 bridge between UE and the EPC, by being the termination point of all the radio protocols towards the UE, and relaying data between the radio connection and the corresponding IP based connectivity towards the EPC. In this role, the eNodeB performs ciphering/deciphering of the UP data, and also IP header compression/decompression, which means avoiding repeatedly sending the same or sequential data in IP header.

The eNodeB is also responsible for many Control Plane (CP) functions. The eNodeB is responsible for the Radio Resource Management (RRM), i.e. controlling the usage of the radio interface, which includes, for example, allocating resources based on requests, prioritizing and scheduling traffic according to required Quality of Service (QoS), and constant monitoring of the resource usage situation.

In addition, the eNodeB has an important role in Mobility Management (MM). The eNodeB controls and analyses radio signal level measurements carried out by the UE, makes similar measurements itself, and based on those makes decisions to handover UEs between cells. This includes exchanging handover signalling between other eNodeBs and the MME. When a new UE activates under eNodeB and requests connection to the network, the eNodeB is also responsible for routing this request to the MME that previously served that UE, or selecting a new MME, if a route to the previous MME is not available or routing information is absent.

Details of these and other E-UTRAN radio interface functions are described extensively elsewhere in this book. The eNodeB has a central role in many of these functions.

Figure 3.3 shows the connections that eNodeB has to the surrounding logical nodes, and summarizes the main functions in these interfaces. In all the connections the eNodeB may be in a one-to-many or a many-to-many relationship. The eNodeB may be serving multiple UEs at its coverage area, but each UE is connected to only one eNodeB at a time. The eNodeB will need to be connected to those of its neighbouring eNodeBs with which a handover may need to be made.

Both MMEs and S-GWs may be pooled, which means that a set of those nodes is assigned to serve a particular set of eNodeBs. From a single eNodeB perspective this means that it may need to connect to many MMEs and S-GWs. However, each UE will be served by only one MME and S-GW at a time, and the eNodeB has to keep track of this association. This associa-

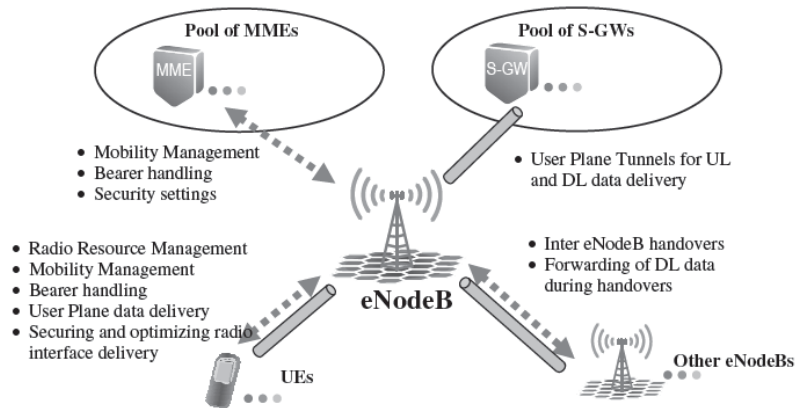

Figure 3.3 eNodeB connections to other logical nodes and main functions

tion will never change from a single eNodeB point of view, because MME or S-GW can only change in association with inter-eNodeB handover.

3.2.2.3 Mobility Management Entity (MME)

Mobility Management Entity (MME) is the main control element in the EPC. Typically the MME would be a server in a secure location in the operator's premises. It operates only in the CP, and is not involved in the path of UP data.

In addition to interfaces that terminate to MME in the architecture as shown in Figure 3.2, the MME also has a logically direct CP connection to the UE, and this connection is used as the primary control channel between the UE and the network. The following lists the main MME functions in the basic System Architecture Configuration:

- **Authentication and Security:** When a UE registers to the network for the first time, the MME initiates the authentication, by performing the following: it finds out the UE's permanent identity either from the previously visited network or the UE itself; requests from the Home Subscription Server (HSS) in UE's home network the authentication vectors which contain the authentication challenge – response parameter pairs; sends the challenge to the UE; and compares the response received from the UE to the one received from the home network. This function is needed to assure that the UE is who it claims to be. The details of EPS-AKA authentication are defined in [4]. The MME may repeat authentication when needed or periodically. The MME will calculate UEs ciphering and integrity protection keys from the master key received in the authentication vector from the home network, and it controls the related settings in E-UTRAN for UP and CP separately. These functions are used to protect the communication from eavesdropping and from alteration by unauthorized third parties respectively. To protect the UE privacy, MME also allocates each UE a temporary identity called the Globally Unique Temporary Identity (GUTI), so that the need to send the permanent UE identity – International Mobile Subscriber Identity (IMSI) – over the

radio interface is minimized. The GUTI may be re-allocated, e.g. periodically to prevent unauthorized UE tracking.

- **Mobility Management:** The MME keeps track of the location of all UEs in its service area. When a UE makes its first registration to the network, the MME will create an entry for the UE, and signal the location to the HSS in the UE's home network. The MME requests the appropriate resources to be set up in the eNodeB, as well as in the S-GW which it selects for the UE. The MME will then keep tracking the UE's location either on the level of eNodeB, if the UE remains connected, i.e. is in active communication, or at the level of Tracking Area (TA), which is a group of eNodeBs in case the UE goes to idle mode, and maintaining a through connected data path is not needed. The MME controls the setting up and releasing of resources based on the UE's activity mode changes. The MME also participates in control signalling for handover of an active mode UE between eNodeBs, S-GWs or MMEs. MME is involved in every eNodeB change, since there is no separate Radio Network Controller to hide most of these events. An idle UE will report its location either periodically, or when it moves to another Tracking Area. If data are received from the external networks for an idle UE, the MME will be notified, and it requests the eNodeBs in the TA that is stored for the UE to page the UE.
- **Managing Subscription Profile and Service Connectivity:** At the time of a UE registering to the network, the MME will be responsible for retrieving its subscription profile from the home network. The MME will store this information for the duration it is serving the UE. This profile determines what Packet Data Network connections should be allocated to the UE at network attachment. The MME will automatically set up the default bearer, which gives the UE the basic IP connectivity. This includes CP signalling with the eNodeB, and the S-GW. At any point later on, the MME may need to be involved in setting up dedicated bearers for services that benefit from higher treatment. The MME may receive the request to set up a dedicated bearer either from the S-GW if the request originates from the operator service domain, or directly from the UE, if the UE requires a connection for a service that is not known by the operator service domain, and therefore cannot be initiated from there.

Figure 3.4 shows the connections MME has to the surrounding logical nodes, and summarizes the main functions in these interfaces. In principle the MME may be connected to any other MME in the system, but typically the connectivity is limited to one operator network only. The remote connectivity between MMEs may be used when a UE that has travelled far away while powered down registers to a new MME, which then retrieves the UE's permanent identity, the International Mobile Subscriber Identity (IMSI), from the previously visited MME. The inter-MME connection with neighbouring MMEs is used in handovers.

Connectivity to a number of HSSs will also need to be supported. The HSS is located in each user's home network, and a route to that can be found based on the IMSI. Each MME will be configured to control a set of S-GWs and eNodeBs. Both the S-GWs and eNodeBs may also be connected to other MMEs. The MME may serve a number of UEs at the same time, while each UE will only connect to one MME at a time.

3.2.2.4 Serving Gateway (S-GW)

In the Basic System Architecture configuration, the high level function of S-GW is UP tunnel management and switching. The S-GW is part of the network infrastructure maintained centrally in operation premises.

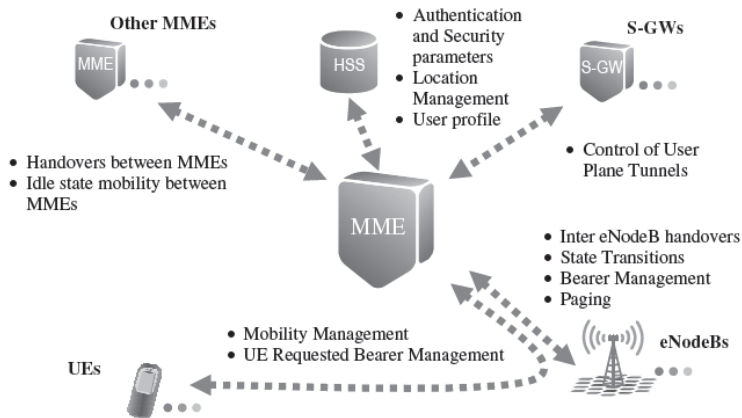

Figure 3.4 MME connections to other logical nodes and main functions

When the S5/S8 interface is based on GTP, the S-GW will have GTP tunnels on all its UP interfaces. Mapping between IP service flows and GTP tunnels is done in P-GW, and the S-GW does not need to be connected to PCRF. All control is related to the GTP tunnels, and comes from either MME or P-GW. When the S5/S8 interface uses PMIP, the S-GW will perform the mapping between IP service flows in S5/S8 and GTP tunnels in S1-U interfaces, and will connect to PCRF to receive the mapping information.

The S-GW has a very minor role in control functions. It is only responsible for its own resources, and it allocates them based on requests from MME, P-GW or PCRF, which in turn are acting on the need to set up, modify or clear bearers for the UE. If the request was received from P-GW or PCRF, the S-GW will also relay the command on to the MME so that it can control the tunnel to eNodeB. Similarly, when the MME initiated the request, the S-GW will signal on to either the P-GW or the PCRF, depending on whether S5/S8 is based on GTP or PMIP respectively. If the S5/S8 interface is based on PMIP, the data in that interface will be IP flows in one GRE tunnel for each UE, whereas in the GTP based S5/S8 interface each bearer will have its own GTP tunnel. Therefore S-GW supporting PMIP S5/S8 is responsible for bearer binding, i.e. mapping the IP flows in S5/S8 interface to bearers in the S1 interface. This function in S-GW is called Bearer Binding and Event Reporting Function (BBERF). Irrespective of where the bearer signalling started, the BBERF always receives the bearer binding information from PCRF.

During mobility between eNodeBs, the S-GW acts as the local mobility anchor. The MME commands the S-GW to switch the tunnel from one eNodeB to another. The MME may also request the S-GW to provide tunnelling resources for data forwarding, when there is a need to forward data from source eNodeB to target eNodeB during the time UE makes the radio handover. The mobility scenarios also include changing from one S-GW to another, and the MME controls this change accordingly, by removing tunnels in the old S-GW and setting them up in a new S-GW.

For all data flows belonging to a UE in connected mode, the S-GW relays the data between eNodeB and P-GW. However, when a UE is in idle mode, the resources in eNodeB are released, and the data path terminates in the S-GW. If S-GW receives data packets from P-GW on any such

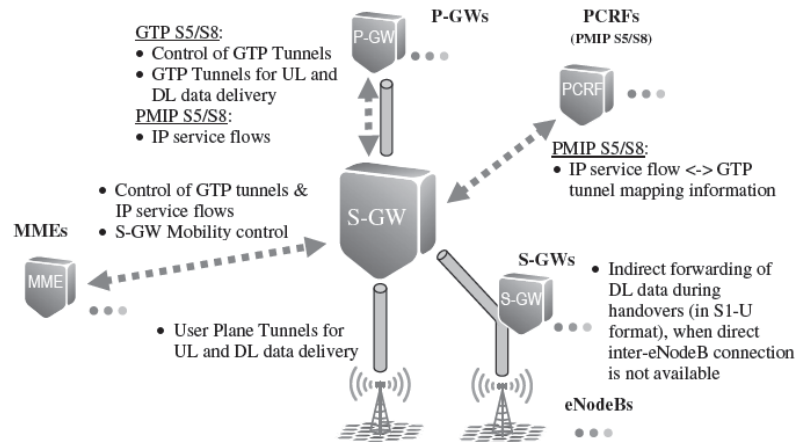

Figure 3.5 S-GW connections to other logical nodes and main functions

tunnel, it will buffer the packets, and request the MME to initiate paging of the UE. Paging will cause the UE to re-connect, and when the tunnels are re-connected, the buffered packets will be sent on. The S-GW will monitor data in the tunnels, and may also collect data needed for accounting and user charging. The S-GW also includes functionality for Lawful Interception, which means the capability to deliver the monitored user's data to authorities for further inspection.

Figure 3.5 shows how the S-GW is connected to other logical nodes, and lists the main functions in these interfaces. All interfaces have to be configured in a one-to-many fashion from the S-GW point of view. One S-GW may be serving only a particular geographical area with a limited set of eNodeBs, and likewise there may be a limited set of MMEs that control that area. The S-GW should be able to connect to any P-GW in the whole network, because P-GW will not change during mobility, while the S-GW may be relocated, when the UE moves. For connections related to one UE, the S-GW will always signal with only one MME, and the UP points to one eNodeB at a time (indirect data forwarding is the exception, see next paragraph). If one UE is allowed to connect to multiple PDNs through different P-GWs, then the S-GW needs to connect to those separately. If the S5/S8 interface is based on PMIP, the S-GW connects to one PCRF for each separate P-GW the UE is using.

Figure 3.5 also shows the indirect data forwarding case where UP data is forwarded between eNodeBs through the S-GWs. There is no specific interface name associated to the interface between S-GWs, since the format is exactly the same as in the S1-U interface, and the involved S-GWs may consider that they are communicating directly with an eNodeB. This would be the case if indirect data forwarding takes place via only one S-GW, i.e. both eNodeBs can be connected to the same S-GW.

3.2.2.5 Packet Data Network Gateway (P-GW)

Packet Data Network Gateway (P-GW, also often abbreviated as PDN-GW) is the edge router between the EPS and external packet data networks. It is the highest level mobility anchor

in the system, and usually it acts as the IP point of attachment for the UE. It performs traffic gating and filtering functions as required by the service in question. Similarly to the S-GW, the P-GWs are maintained in operator premises in a centralized location.

Typically the P-GW allocates the IP address to the UE, and the UE uses that to communicate with other IP hosts in external networks, e.g. the internet. It is also possible that the external PDN to which the UE is connected allocates the address that is to be used by the UE, and the P-GW tunnels all traffic to that network. The IP address is always allocated when the UE requests a PDN connection, which happens at least when the UE attaches to the network, and it may happen subsequently when a new PDN connectivity is needed. The P-GW performs the required Dynamic Host Configuration Protocol (DHCP) functionality, or queries an external DHCP server, and delivers the address to the UE. Also dynamic auto-configuration is supported by the standards. Only IPv4, only IPv6 or both addresses may be allocated depending on the need, and the UE may signal whether it wants to receive the address(es) in the Attach signalling, or if it wishes to perform address configuration after the link layer is connected.

The P-GW includes the PCEF, which means that it performs gating and filtering functions as required by the policies set for the UE and the service in question, and it collects and reports the related charging information.

The UP traffic between P-GW and external networks is in the form of IP packets that belong to various IP service flows. If the S5/S8 interface towards S-GW is based on GTP, the P-GW performs the mapping between the IP data flows to GTP tunnels, which represent the bearers. The P-GW sets up bearers based on request either through the PCRF or from the S-GW, which relays information from the MME. In the latter case, the P-GW may also need to interact with the PCRF to receive the appropriate policy control information, if that is not configured in the P-GW locally. If the S5/S8 interface is based on PMIP, the P-GW maps all the IP Service flows from external networks that belong to one UE to a single GRE tunnel, and all control information is exchanged with PCRF only. The P-GW also has functionality for monitoring the data flow for accounting purposes, as well as for Lawful Interception.

P-GW is the highest level mobility anchor in the system. When a UE moves from one S-GW to another, the bearers have to be switched in the P-GW. The P-GW will receive an indication to switch the flows from the new S-GW.

Figure 3.6 shows the connections P-GW has to the surrounding logical nodes, and lists the main functions in these interfaces. Each P-GW may be connected to one or more PCRF, S-GW and external network. For a given UE that is associated with the P-GW, there is only one S-GW, but connections to many external networks and respectively to many PCRFs may need to be supported, if connectivity to multiple PDNs is supported through one P-GW.

3.2.2.6 Policy and Charging Resource Function (PCRF)

Policy and Charging Resource Function (PCRF) is the network element that is responsible for Policy and Charging Control (PCC). It makes decisions on how to handle the services in terms of QoS, and provides information to the PCEF located in the P-GW, and if applicable also to the BBERF located in the S-GW, so that appropriate bearers and policing can be set up. PCRF is part of the PCC framework defined in [5]. PCRF is a server usually located with other CN elements in operator switching centres.

The information the PCRF provides to the PCEF is called the PCC rules. The PCRF will send the PCC rules whenever a new bearer is to be set up. Bearer set-up is required, for exam-

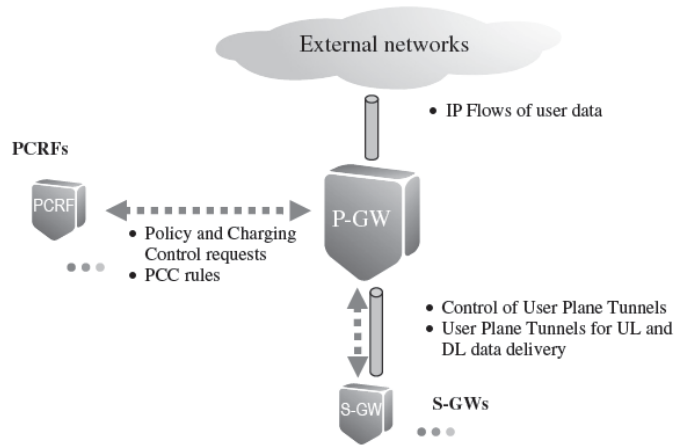

Figure 3.6 P-GW connections to other logical nodes and main functions

ple, when the UE initially attaches to the network and the default bearer will be set up, and subsequently when one or more dedicated bearers are set up. The PCRF will be able to provide PCC rules based on request either from the P-GW and also the S-GW in PMIP case, like in the attach case, and also based on request from the Application Function (AF) that resides in the Services Domain. In this scenario the UE has signalled directly with the Services Domain, e.g. with the IMS, and the AF pushes the service QoS information to PCRF, which makes a PCC decision, and pushes the PCC rules to the P-GW, and bearer mapping information to S-GW in PMIP S5/S8 case. The EPC bearers are then set up based on those.

The connections between the PCRF and the other nodes are shown in Figure 3.7. Each PCRF may be associated with one or more AF, P-GW and S-GW. There is only one PCRF associated with each PDN connection that a single UE has.

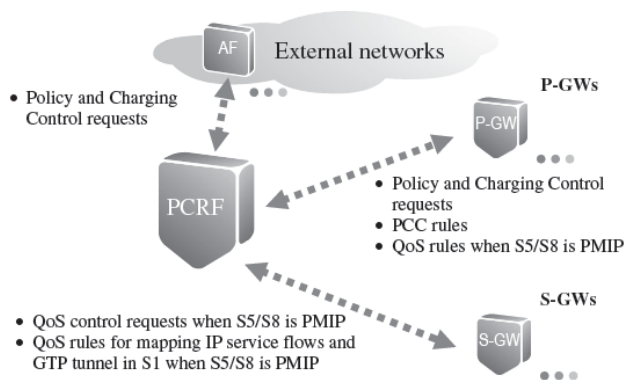

Figure 3.7 PCRF connections to other logical nodes and main functions

3.2.2.7 Home Subscription Server (HSS)

Home Subscription Server (HSS) is the subscription data repository for all permanent user data. It also records the location of the user in the level of visited network control node, such as MME. It is a database server maintained centrally in the home operator's premises.

The HSS stores the master copy of the subscriber profile, which contains information about the services that are applicable to the user, including information about the allowed PDN connections, and whether roaming to a particular visited network is allowed or not. For supporting mobility between non-3GPP ANs, the HSS also stores the Identities of those P-GWs that are in use. The permanent key, which is used to calculate the authentication vectors that are sent to a visited network for user authentication and deriving subsequent keys for encryption and integrity protection, is stored in the Authentication Center (AuC), which is typically part of the HSS. In all signalling related to these functions, the HSS interacts with the MME. The HSS will need to be able to connect with every MME in the whole network, where its UEs are allowed to move. For each UE, the HSS records will point to one serving MME at a time, and as soon as a new MME reports that it is serving the UE, the HSS will cancel the location from the previous MME.

3.2.2.8 Services Domain

The Services domain may include various sub-systems, which in turn may contain several logical nodes. The following is a categorization of the types of services that will be made available, and a short description of what kind of infrastructure would be needed to provide them:

- IMS based operator services: The IP Multimedia Sub-system (IMS) is service machinery that the operator may use to provide services using the Session Initiation Protocol (SIP). IMS has 3GPP defined architecture of its own, and is described in section 3.6, and more thoroughly, e.g. in [3].
- Non-IMS based operator services: The architecture for non-IMS based operator services is not defined in the standards. The operator may simply place a server into their network, and the UEs connect to that via some agreed protocol that is supported by an application in the UE. A video streaming service provided from a streaming server is one such example.
- Other services not provided by the mobile network operator, e.g. services provided through the internet: This architecture is not addressed by the 3GPP standards, and the architecture depends on the service in question. The typical configuration would be that the UE connects to a server in the internet, e.g. to a web-server for web browsing services, or to a SIP server for internet telephony service (i.e. VoIP).

3.2.3 Self-configuration of S1-MME and X2 interfaces

In 3GPP Release 8 development it has been agreed to define the support for self-configuration of the S1-MME and X2 interfaces. The basic process is as presented in Figure 3.8, where the eNodeB once turned on (and given that the IP connection exists) will connect to the O&M (based on the known IP address) to obtain then further parameters in terms of which other network elements to connect (and also for eNodeB software download) as well as initial parameters for the operation, such as in which part of the frequency band to operate and what kind of parameters to include for the broadcast channels.

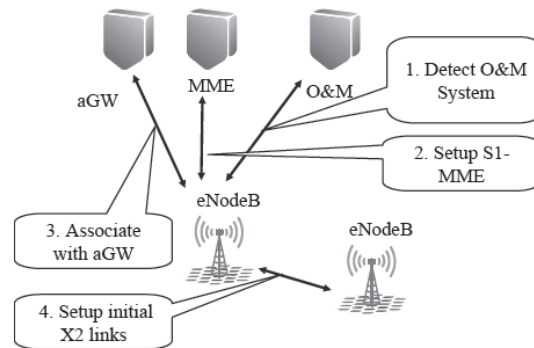

Figure 3.8 eNodeB self-configuration steps

This is expected to include setting the S1-MME connection by first setting up the SCTP association with at least one MME, and once that is connected to continue with application level information exchange to make S1-MME interface operational. Once the link to MME exists, there needs to be then association with S-GW created for UP data transfer.

To enable functionalities such as mobility and inter-cell interference control, the X2 interface configuration follows similar principles to the S1-MME interface. The difference here is that initially the eNodeB will set up the X2 connection for those eNodeBs indicated from the O&M and it may then later adapt more to the environment based on the Automatic Neighbour Relationship (ANR) functionality – as covered in Chapter 7 – to further optimize the X2 connectivity domain based on actual handover needs. The parameters that are exchanged over the X2 interface include:

- global eNodeB ID;
- information of the cell specific parameters such as Physical Cell ID (PCI), uplink/downlink frequency used, bandwidth in use;
- MMEs connected (MME Pool).

For the PCI there is also support for auto-configuration in the Release 8 specifications as covered in Chapter 5, other parameters then coming from the O&M direction with procedures that can be automated to limit the need for on-site configuration by installation personnel.

3.2.4 Interfaces and Protocols in Basic System Architecture Configuration

Figure 3.9 shows the CP protocols related to a UE's connection to a PDN. The interfaces from a single MME are shown in two parts, the one on top showing protocols towards the E-UTRAN and UE, and the bottom one showing protocols towards the gateways. Those protocols that are shown in white background are developed by 3GPP, while the protocols with light grey background are developed in IETF, and represent standard internet technologies that are used for transport in EPS. 3GPP has only defined the specific ways of how these protocols are used.

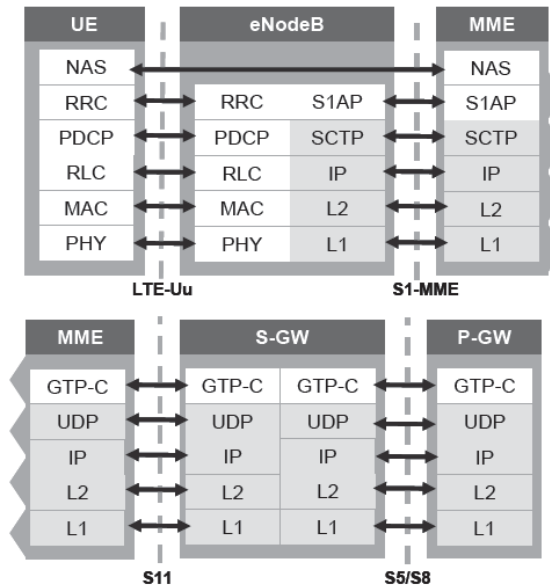

Figure 3.9 Control plane protocol stack in EPS

The topmost layer in the CP is the Non-Access Stratum (NAS), which consists of two separate protocols that are carried on direct signalling transport between the UE and the MME. The content of the NAS layer protocols is not visible to the eNodeB, and the eNodeB is not involved in these transactions by any other means, besides transporting the messages, and providing some additional transport layer indications along with the messages in some cases. The NAS layer protocols are:

- **EPS Mobility Management (EMM):** The EMM protocol is responsible for handling the UE mobility within the system. It includes functions for attaching to and detaching from the network, and performing location updating in between. This is called Tracking Area Updating (TAU), and it happens in idle mode. Note that the handovers in connected mode are handled by the lower layer protocols, but the EMM layer does include functions for re-activating the UE from idle mode. The UE initiated case is called Service Request, while Paging represents the network initiated case. Authentication and protecting the UE identity, i.e. allocating the temporary identity GUTI to the UE are also part of the EMM layer, as well as the control of NAS layer security functions, encryption and integrity protection.
- **EPS Session Management (ESM):** This protocol may be used to handle the bearer management between the UE and MME, and it is used in addition for E-UTRAN bearer management procedures. Note that the intention is not to use the ESM procedures if the bearer contexts are already available in the network and E-UTRAN procedures can be run immediately. This would be the case, for example, when the UE has already signalled with an operator affiliated Application Function in the network, and the relevant information has been made available through the PCRF.

The radio interface protocols are (only short descriptions are included here, since these functions are described extensively in other sections of this book):

- Radio Resource Control (RRC): This protocol is in control of the radio resource usage. It manages UE's signalling and data connections, and includes functions for handover.
- Packet Data Convergence Protocol (PDCP): The main functions of PDCP are IP header compression (UP), encryption and integrity protection (CP only).
- Radio Link Control (RLC): The RLC protocol is responsible for segmenting and concatenation of the PDCP-PDUs for radio interface transmission. It also performs error correction with the Automatic Repeat Request (ARQ) method.
- Medium Access Control (MAC): The MAC layer is responsible for scheduling the data according to priorities, and multiplexing data to Layer 1 transport blocks. The MAC layer also provides error correction with Hybrid ARQ.
- Physical Layer (PHY): This is the Layer 1 of LTE-Uu radio interface that takes care of DS-CDMA Layer functions.

The S1 interface connects the E-UTRAN to the EPC, and involves the following protocols:

- S1 Application Protocol (S1AP): S1AP handles the UE's CP and UP connections between the E-UTRAN and EPC, including participating in the handover when EPC is involved.
- SCTP/IP signalling transport: The Stream Control Transmission Protocol (SCTP) and Internet Protocol (IP) represent standard IP transport suitable for signalling messages. SCTP provides the reliable transport and sequenced delivery functions. IP itself can be run on a variety of data link and physical layer technologies (L2 and L1), which may be selected based on availability.

In the EPC, there are two alternative protocols for the S5/S8 interface. The following protocols are involved, when GTP is used in S5/S8:

- GPRS Tunnelling Protocol, Control Plane (GTP-C): It manages the UP connections in the EPC. This includes signalling the QoS and other parameters. If GTP is used in the S5/S8 interface it also manages the GTP-U tunnels. GTP-C also performs the mobility management functions within the EPC, e.g. when the GTP-U tunnels of a UE need to be switched from one node to the other.
- UDP/IP transport. The User Datagram Protocol (UDP) and IP are used as the standard and basic IP transport. UDP is used instead of Transmission Control Protocol (TCP) because the higher layers already provide reliable transport with error recovery and re-transmission. IP packets in EPC may be transported on top of a variety of L2 and L1 technologies. Ethernet and ATM are some examples.

The following protocols are used, when S5/S8 is based on PMIP:

- Proxy Mobile IP (PMIP): PMIP is the alternative protocol for the S5/S8 interface. It takes care of mobility management, but does not include bearer management functions as such. All traffic belonging to a UE's connection to a particular PDN is handled together.
- IP: PMIP runs directly on top of IP, and it is used as the standard IP transport.

Figure 3.10 illustrates the UP protocol structure for UE connecting to P-GW.

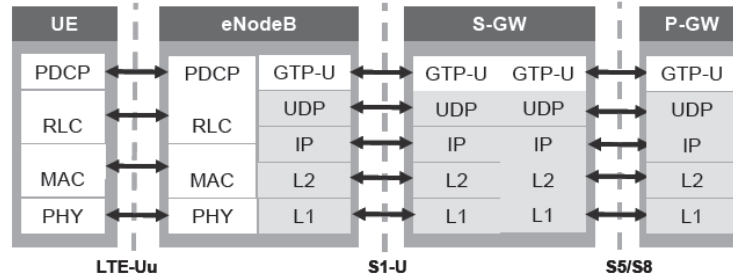

Figure 3.10 User plane protocol stack in EPS

The UP shown in Figure 3.10 includes the layers below the end user IP, i.e. these protocols form the Layer 2 used for carrying the end user IP packets. The protocol structure is very similar to the CP. This highlights the fact that the whole system is designed for generic packet data transport, and both CP signalling and UP data are ultimately packet data. Only the volumes are different. Most of the protocols have been introduced already above, with the exception of the following two that follow the selection of protocol suite in S5/S8 interface:

- GPRS Tunnelling Protocol, User Plane (GTP-U): GTP-U is used when S5/S8 is GTP based. GTP-U forms the GTP-U tunnel that is used to send End user IP packets belonging to one EPS bearer. It is used in S1-U interface, and is used in S5/S8 if the CP uses GTP-C.
- Generic Routing Encapsulation (GRE): GRE is used in the S5/S8 interface in conjunction with PMIP. GRE forms an IP in IP tunnel for transporting all data belonging to one UE's connection to a particular PDN. GRE is directly on top of IP, and UDP is not used.

Figure 3.11 illustrates the X2 interface protocol structure, which resembles that of the S1 interface. Only the CP Application Protocol is different. X2 interface is used in mobility between the eNodeBs, and the X2AP includes functions for handover preparation, and overall maintenance of the relation between neighbouring eNodeBs. The UP in the X2 interface is used for forwarding data in a transient state during handover, when the radio interface is already

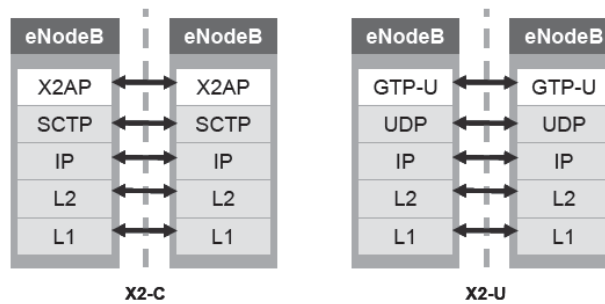

Figure 3.11 Control and user plane protocol stacks for X2 interface

Table 3.1 Summary of interfaces and protocols in Basic System Architecture configuration

Interface	Protocols	Specification
LTE-Uu	CP: RRC/PDCP/RLC/MAC/PHY UP: PDCP/RLC/MAC/PHY	36.300 [6] (stage 2)
X2	CP: X2AP/SCTP/IP UP: GTP-U/UDP/IP	36.423 [7] 29.274 [8]
S1-MME	S1AP/SCTP/UDP/IP	36.413 [9]
S1-U	GTP-U/UDP/IP	29.274 [8]
S10	GTP-C/UDP/IP	29.274 [8]
S11	GTP-C/UDP/IP	29.274 [8]
S5/S8 (GTP)	GTP/UDP/IP	29.274 [8]
S5/S8 (PMIP)	CP: PMIP/IP UP: GRE/IP	29.275 [10]
SGi	IP (also Diameter & Radius)	29.061 [11]
S6a	Diameter/SCTP/IP	29.272 [12]
Gx	Diameter/SCTP/IP	29.212 [13]
Gxc	Diameter/SCTP/IP	29.212 [13]
Rx	Diameter/SCTP/IP	29.214 [14]
UE – MME	EMM, ESM	24.301 [15]

disconnected on the source side, and has not yet resumed on the target side. Data forwarding is done for the DL data, since the UL data can be throttled effectively by the UE.

Table 3.1 summarizes the protocols and interfaces in Basic System Architecture configuration.

3.2.5 Roaming in Basic System Architecture Configuration

Roaming is an important functionality, where operators share their networks with each other's subscribers. Typically roaming happens between operators serving different areas, such as different countries, since this does not cause conflicts in the competition between the operators, and the combined larger service area benefits them as well as the subscribers. The words *home* and *visited* are used as prefixes to many other architectural terms to describe where the subscriber originates from and where it roams to respectively.

3GPP SAE specifications define which interfaces can be used between operators, and what additional considerations are needed if an operator boundary is crossed. In addition to the connectivity between the networks, roaming requires that the operators agree on many things at the service level, e.g. what services are available, how they are realized, and how accounting and charging is handled. This agreement is called the *Roaming Agreement*, and it can be made directly between the operators, or through a broker. The 3GPP specifications do not cover these items, and operators using 3GPP technologies discuss roaming related general questions in a private forum called the GSM Association, which has published recommendations to cover these additional requirements.

Roaming defined for SAE follows quite similar principles to the earlier 3GPP architectures. The E-UTRAN is always locally in the visited network, but the data may be routed either to the home network, or can break out to external networks directly from the visited network. This aspect differentiates the two roaming models supported for SAE, which are defined as follows:

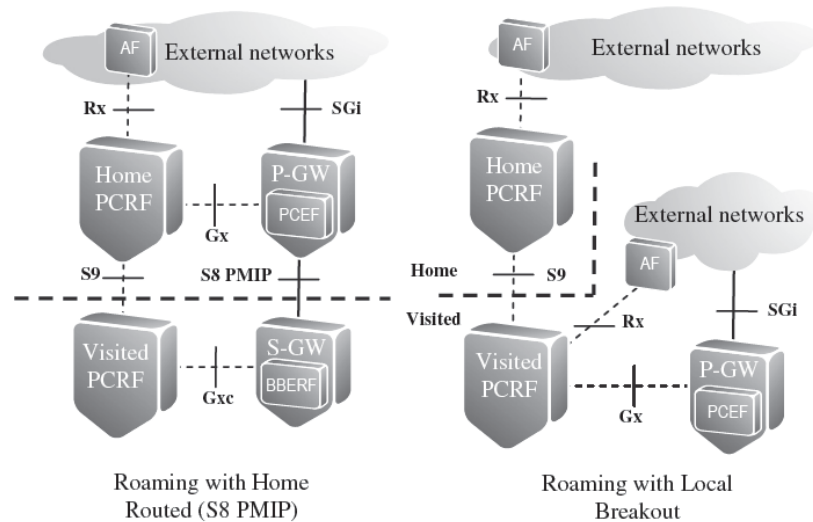

Figure 3.12 Home routed and local breakout roaming

- Home Routed model: The P-GW, HSS and PCRF reside in the home operator network, and the S-GW, MME and the radio networks reside in the visited operator network. In this roaming configuration the interface between P-GW and S-GW is called S8, whereas the same interface is called S5 when S-GW and P-GW are in the same operator's network. S5 and S8 are technically equivalent. When the S8 interface is based in GTP, the roaming architecture is as shown in Figure 3.2 (Gxa does not apply with GTP). When the S8 interface uses PMIP, the PCRF will also be divided into home and visited nodes with the S9 interface between them. This is the scenario shown in Figure 3.12 on the left, and is explained with more detail in section 3.7.1. The Home Routed roaming model applies to legacy 3GPP ANs in the same way, the additional detail being that the SGSN introduced in the next chapter and shown in Figure 3.12 resides in the visited network.
- Local Breakout model: In this model, shown in the right side of Figure 3.12, the P-GW will be located in the visited network, and the HSS is in the home network. If dynamic policy control is used, there will again be two PCRFs involved, one in the home network, and the other in the visited network. Depending on which operator's services are used, the PCRF in that operator's network is also connected to the AF. Also this scenario is explained with more detail in section 3.7.1. With these constraints the Local Breakout model also works with the legacy 3GPP ANs.

3.3 System Architecture with E-UTRAN and Legacy 3GPP Access Networks

3.3.1 Overview of 3GPP Inter-working System Architecture Configuration

Figure 3.13 describes the architecture and network elements in the architecture configuration where all 3GPP defined ANs, E-UTRAN, UTRAN and GERAN, are connected to the EPC.

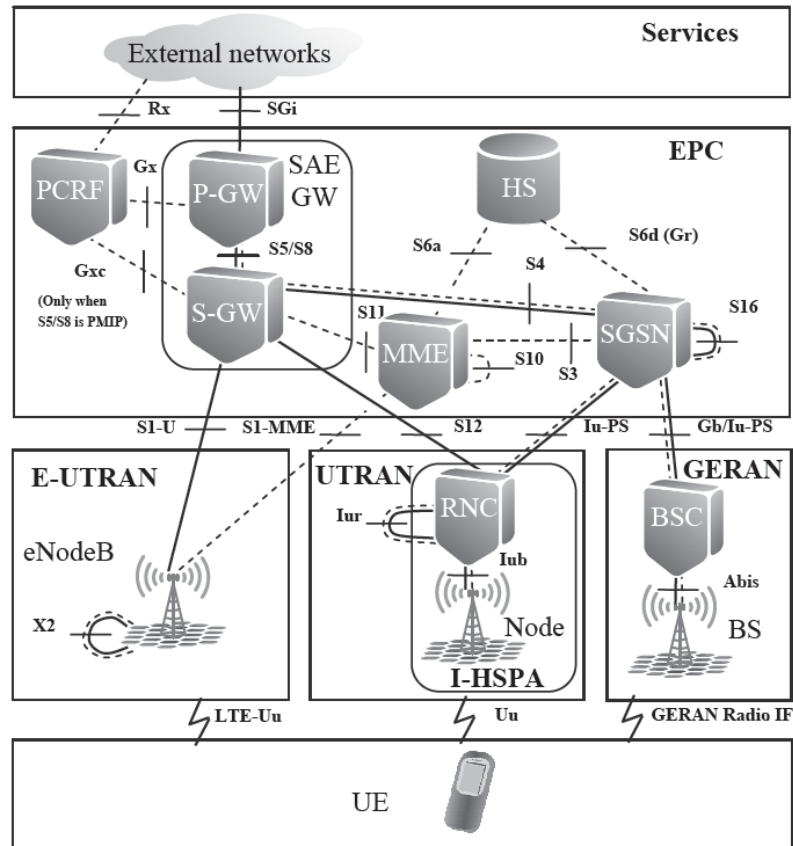

Figure 3.13 System architecture for 3GPP access networks

This is called here the 3GPP Inter-working System Architecture Configuration, and it allows optimized inter-working between the mentioned accesses.

Functionally the E-UTRAN, UTRAN and GERAN all provide very similar connectivity services, especially when looking at the situation from the end user point of view, where the only difference may be the different data rates and improved performance, but architecturally these ANs are quite different, and many things are carried out differently. There are, for example, big differences in how the bearers are managed in the EPS compared to the existing networks with UTRAN or GERAN access. However, when UTRAN or GERAN is connected to EPC, they may still operate as before from this perspective, and for this purpose the S-GW simply assumes the role of the Gateway GPRS Support Node (GGSN). Also in optimized inter-working with the E-UTRAN, the GERAN and UTRAN ANs behave almost the same way as they behave when inter-working between themselves. The differences become more visible in the EPC, because what used to be the fixed GGSN is now the S-GW that may be changed along with the SGSN change during UE mobility.

All nodes and functions described in the previous section for the Basic System Architecture Configuration are needed here also. The EPC needs the addition of a few new interfaces and functions to connect and inter-work with UTRAN and GERAN. The corresponding functions will also be required from GERAN and UTRAN. The new interfaces are S3, S4 and S12 as shown in Figure 3.12. The interface from SGSN to HSS can also be updated to Diameter based S6d, but the use of the legacy MAP based Gr is also possible.

Keeping E-UTRAN, i.e. the eNodeB design as focused to, and as optimized for the requirements of the new OFDMA radio interface, and as clean of inter-working functionality as possible, was an important guideline for the inter-working design. Consequently, the eNodeB does not interface directly with the other 3GPP ANs, and the interaction towards the EPC is the same as in other mobility cases that involve EPC. However, optimized inter-working means that the network is in control of mobility events, such as handovers, and provides functionality to hand the communication over with minimum interruption to services. This means that an eNodeB must be able to coordinate UE measuring UTRAN and GERAN cells, and perform handover decisions based on measurement results, and thus E-UTRAN radio interface protocols have been appended to support the corresponding new functions. Similar additions will be required from UTRAN and GERAN to support handover to E-UTRAN.

3.3.2 Additional and Updated Logical Elements in 3GPP Inter-working System Architecture Configuration

3.3.2.1 User Equipment

From the UE point of view, inter-working means that it needs to support the radio technologies in question, and the mobility operations defined for moving between them. The optimized inter-working means that the network controls the usage of radio transmitter and receiver in the UE in a way that only one set of them needs to be operating at the same time. This is called single radio operation, and allows UE implementations where only one pair of physical radio transmitter and receiver is implemented.

The standard does not preclude implementing multiple radio transmitters and receivers, and operating them simultaneously in dual radio operation. However, single radio operation is an important mode, because the different ANs often operate in frequencies that are so close to each other that dual radio operation would cause too much interference within the terminal. That, together with the additional power consumption, will decrease the overall performance.

3.3.2.2 E-UTRAN

The only addition to E-UTRAN eNodeB compared to the Basic System Architecture Configuration is the mobility to and from other 3GPP ANs. From the eNodeB perspective the functions are very similar irrespective of whether the other 3GPP AN is UTRAN or GERAN.

For the purpose of handover from E-UTRAN to UTRAN or GERAN, the neighbouring cells from those networks need to be configured into the eNodeB. The eNodeB may then consider handover for those UEs that indicate corresponding radio capability. The eNodeB requests the UE to measure the signal level of the UTRAN or GERAN cells, and analyses the measurement reports. If the eNodeB decides to start the handover, it signals the need to the MME in the

same way that it would signal inter-eNodeB handover when the X2 interface is not available. Subsequently, the eNodeB will receive the information needed for the Handover Command from the target Access System via the MME. The eNodeB will send the Handover Command to the UE without the need for interpreting the content of this information.

In the case of handover from UTRAN or GERAN to E-UTRAN, the eNodeB does not need to make any specific preparations compared to other handovers where the handover preparation request comes through the MME. The eNodeB will allocate the requested resources, and prepare the information for handover command, which it sends to the MME, from where it is delivered to the UE through the other 3GPP Access System that originated the handover.

3.3.2.3 UTRAN

In UTRAN, the radio control functionality is handled by the Radio Network Controller (RNC), and under its control the Node B performs Layer 2 bridging between the Uu and Iub interfaces. UTRAN functionality is described extensively in [16].

UTRAN has evolved from its initial introduction in Release 99 in many ways, including the evolution of architectural aspects. The first such item is Iu flex, where the RNC may be connected to many Serving GPRS Support Nodes (SGSNs) instead of just one. Another such concept is I-HSPA, where the essential set of packet data related RNC functions is included with the Node B, and that connects to Iu-PS as a single node. Figure 3.13 also shows the direct UP connection from RNC to S-GW, which is introduced to 3G CN by the Direct Tunnel concept, where the SGSN is bypassed in UP.

Inter-working with E-UTRAN requires that UTRAN performs the same measurement control and analysis functions as well as the transparent handover information delivery in Handover Command that were described for eNodeB in the earlier section. Also the UTRAN performs similar logic that it already uses with Relocation between RNCs, when the Iur interface is not used.

3.3.2.4 GERAN

GSM EDGE Radio AN (GERAN) is the evolved version of GSM AN, which can also be connected to 3G Core Network. It consists of the Base Station Controller (BSC) and the Base Station (BS), and the radio interface functionalities are divided between them. An overview of GERAN functionality and the whole GSM system can be found in [17].

The GERAN is always connected to the SGSN in both Control and UPs, and this connection is used for all the inter-working functionality. Also the GERAN uses logic similar to that described above for E-UTRAN and UTRAN for inter-working handover.

3.3.2.5 EPC

The EPC has a central role for the inter-working system architecture by anchoring the ANs together. In addition to what has been described earlier, the MME and S-GW will support connectivity and functions for inter-working. Also the SGSN, which supports the UTRAN and GERAN access networks, will need to support these functions, and when these additions are supported, it can be considered to belong to the EPC.

The S-GW is the mobility anchor for all 3GPP access systems. In the basic bearer operations and mobility between SGSNs, it behaves like a GGSN towards the SGSN, and also towards the RNC if UP tunnels are set up in Direct Tunnel fashion bypassing the SGSN. Many of the GGSN functions are actually performed in the P-GW, but this is not visible to the SGSN. The S-GW retains its role as a UP Gateway, which is controlled by either the MME or the SGSN depending on which AN the UE is being served by.

To support the inter-working mobility, the MME will need to signal with the SGSN. These operations are essentially the same as between those two MMEs, and have been described earlier in section 3.2. An additional aspect of the MME is that it may need to combine the change of S-GW and the inter-working mobility with SGSN.

The SGSN maintains its role as the controlling node in core network for both UTRAN and GERAN. These functions are defined in [18]. The SGSN has a role very similar to that of the MME. The SGSN needs to be updated to support for S-GW change during mobility between SGSNs or RNCs, because from the legacy SGSN point of view this case looks like GGSN changing, which is not supported. As discussed earlier, the SGSN may direct the UP to be routed directly between the S-GW and UTRAN RNC, or it may remain involved in the UP handling. From the S-GW point of view this does not really make a difference, since it does not need to know which type of node terminates the far end of the UP tunnel.

3.3.3 Interfaces and Protocols in 3GPP Inter-working System Architecture Configuration

Table 3.2 summarizes the interfaces in the 3GPP Inter-working System Architecture Configuration and the protocols used in them. Interfaces and protocols in legacy 3GPP networks are not listed. Interfaces and protocols listed for Basic System Architecture Configuration are needed in addition to these.

3.3.4 Inter-working with Legacy 3GPP CS Infrastructure

While the EPS is purely a Packet Switched (PS) only system without a specific Circuit Switched (CS) domain with support for VoIP, the legacy 3GPP systems treat CS services such as voice calls with a specific CS infrastructure. IMS VoIP may not be ubiquitously available, and therefore the SAE design includes two special solutions that address inter-working with circuit switched voice. A description of how inter-working between E-UTRAN and the legacy 3GPP CS domain can be

Table 3.2 Summary of additional interfaces and protocols in 3GPP Inter-working System Architecture configuration

Interface	Protocols	Specification
S3	GTP-C/UDP/IP	29.274 [8]
S4	GTP/UDP/IP	29.274 [8]
S12	GTP-U/UDP/IP	29.274 [8]
S16	GTP/UDP/IP	29.274 [8]
S6d	Diameter/SCTP/IP	29.272 [12]

Table 3.3 Summary of additional interfaces and protocols for inter-working with legacy 3GPP CS infrastructure

Interface	Protocols	Specification
SGs	SGsAP/SCTP/IP	29.118 [21]
Sv	GTP-C(subset)/UDP/IP	29.280 [22]

arranged is given in Chapter 10 on VoIP. Two specific functions have been defined for that purpose, Circuit Switched Fall Back (CSFB) and Single Radio Voice Call Continuity (SR-VCC).

CSFB [19] is a solution for networks that do not have support for IMS VoIP. Instead, the voice calls are handled by the CS domain, and the UE is handed over there at the time of a voice call. The SGs interface between the MME and MSC Server is used for related control signalling, as shown with more detail in Chapter 10.

SR-VCC [20] is a solution for converting and handing over an IMS VoIP call to a CS voice call in the legacy CS domain. This functionality would be needed when the coverage of an IMS VoIP capable network is smaller than that of the legacy CS networks. SR-VCC allows a UE entering the edge of the VoIP coverage area with an ongoing VoIP call to be handed over to the CS network without interrupting the call. SR-VCC is a one way handover from the PS network with VoIP to the CS network. If E-UTRAN coverage becomes available again, the UE may return there when the call ends and the UE becomes idle. The solution relies on running only one radio at a time, i.e. the UE does not need to communicate simultaneously with both systems. In this solution the MME is connected to the MSC Server in the CS domain via a Sv interface, which is used for control signalling in the SR-VCC handover. The details of the solution are presented in Chapter 10. A summary of additional interfaces and protocols for inter-working with legacy 3GPP CS infrastructure is given in Table 3.3.

3.4 System Architecture with E-UTRAN and Non-3GPP Access Networks

3.4.1 Overview of 3GPP and Non-3GPP Inter-working System Architecture Configuration

Inter-working with non-3GPP ANs was one of the key design goals for SAE, and to support it, a completely separate architecture specification [2] was developed in 3GPP. The non-3GPP Inter-working System Architecture includes a set of solutions in two categories. The first category contains a set of generic and loose inter-working solutions that can be used with any other non-3GPP AN. Mobility solutions defined in this category are also called Handovers without Optimizations, and the same procedures are applicable in both connected and idle mode. The second category includes a specific and tighter inter-working solution with one selected AN, the cdma2000[®] HRPD. This solution category is also called Handovers with Optimizations, and it specifies separate procedures for connected and idle mode.

The generic non-3GPP Inter-working System Architecture is shown in Figure 3.14. The specific application of the architecture for cdma2000[®] HRPD inter-working and the required additional interfaces are described with more detail in section 3.5.

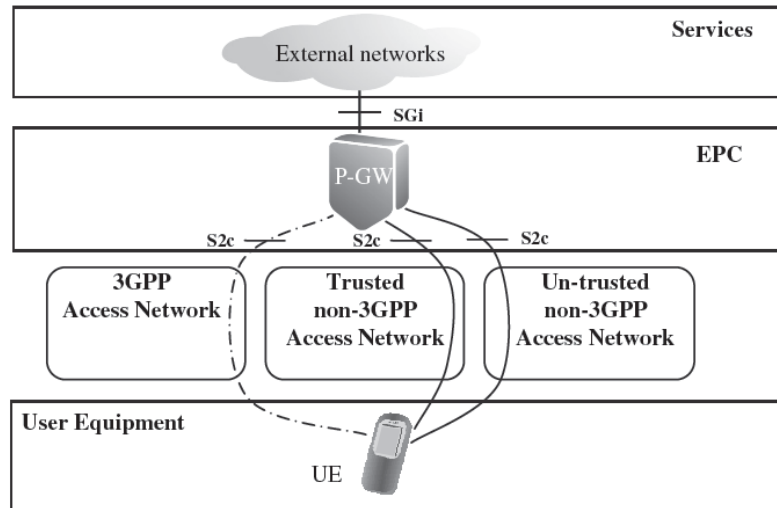

Figure 3.15 Simplified system architecture showing only S2c

In addition to the network controlled mobility solutions, a completely UE centric solution with DSMIPv6 is also included in the inter-working solutions. This scenario is depicted in Figure 3.15.

In this configuration the UE may register in any non-3GPP AN, receive an IP address from there, and register that to the Home Agent in P-GW. This solution addresses the mobility as an overlay function. While the UE is served by one of the 3GPP ANs, the UE is considered to be in home link, and thus the overhead caused by additional MIP headers is avoided.

Another inter-working scenario that brings additional flexibility is called the chained S8 and S2a/S2b scenario. In that scenario the non-3GPP AN is connected to S-GW in the visited Public Land Mobile Network (PLMN) through the S2a or S2b interface, while the P-GW is in the home PLMN. This enables the visited network to offer a roaming subscriber the use of non-3GPP ANs that might not be associated with the home operator at all, even in the case where P-GW is in the home PLMN. This scenario requires that S-GW performs functions that normally belong to P-GW in order to behave as the termination point for the S2a or S2b interfaces. In Release 8, this scenario does not support dynamic policies through the PCC infrastructure, i.e. the Gxc interface will not be used. Also, chaining with GTP based S5/S8 is not supported. All other interfaces related to non-3GPP ANs are used normally as shown in Figure 3.14.

3.4.2 Additional and Updated Logical Elements in 3GPP Inter-working System Architecture Configuration

3.4.2.1 User Equipment

Inter-working between the non-3GPP ANs requires that the UE supports the corresponding radio technologies, and the specified mobility procedures. The mobility procedures and required

radio capabilities vary depending on whether optimizations are in place or not. The procedures defined for Handovers without Optimizations do not make any assumption about the UE's capability to use the radio transmitters and receivers simultaneously, and both single radio and dual radio configurations can use the procedures. However, the handover gap time is expected to be shorter, if preparing the connections towards the target side can start already while data are still flowing through the source side. This is caused by the fact that Handovers without Optimizations do not have procedures in the network side to assist in handover preparations, and the procedures follow the principle where UE registers to the target network according to the method defined for that network, and then the network switches the flow to the target network. This may be time consuming, since it normally includes procedures such as authentication. Also, the decision to make these handovers is the responsibility of the UE.

The Handovers with Optimizations, i.e. inter-working with cdma2000[®] HRPD, assume that they do include network control for connected mode, so the handovers are decided by the network, while the idle mode mobility relies on UE decision making, which may use cdma2000[®] HRPD related information in the LTE-Uu broadcast. Furthermore, the procedures are designed with the assumption that single radio configuration is enough for the UE.

3.4.2.2 Trusted Non-3GPP Access Networks

The term trusted non-3GPP AN refers to networks that can be trusted to run 3GPP defined authentication. 3GPP Release 8 security architecture specification for non-3GPP ANs [23] mandates that the Improved Extensible Authentication Protocol Method for 3rd Generation Authentication and Key Agreement (EAP-AKA') [24] is performed. The related procedures are performed over the STa interface.

The trusted non-3GPP ANs are typically other mobile networks, such as the cdma2000[®] HRPD. The STa interface supports also delivery of subscription profile information from Authentication, Authorization and Accounting (AAA)/HSS to the AN, and charging information from the AN to AAA Server, which are typical functions needed in mobile networks. It can also be assumed that such ANs may benefit from connecting to the PCC infrastructure, and therefore the Gxc interface may be used to exchange related information with the PCRF.

The trusted non-3GPP AN connects to the P-GW with the S2a interface, with either PMIP or MIPv4 Foreign Agent mode. The switching of UP flows in P-GW is therefore the responsibility of the trusted non-3GPP AN when UE moves into the AN's service area.

3.4.2.3 Un-trusted Non-3GPP Access Networks

To a large extent, the architectural concepts that apply for un-trusted non-3GPP ANs are inherited from the Wireless Local Area Network Inter-Working (WLAN IW) defined originally in Release 6 [25]. The Release 8 functionality for connecting un-trusted non-3GPP ANs to EPC is specified fully in [2] with references to the earlier WLAN IW specifications when applicable.

The main principle is that the AN is not assumed to perform any other functions besides delivery of packets. A secure tunnel is established between UE and a special node called the Enhanced Packet Data Gateway (EPDG) via the SWu interface, and the data delivery takes place through that tunnel. Furthermore, the P-GW has a trust relationship with the EPDG con-

nected to it via the S2b interface, and neither node needs to have secure association with the un-trusted non-3GPP AN itself.

As an optional feature, the un-trusted non-3GPP AN may be connected to the AAA Server with the SWa interface, and this interface may be used to authenticate the UE already in the non-3GPP AN level. This can be done only in addition to authentication and authorization with the EPDG.

3.4.2.4 EPC

The EPC includes quite a few additional functions for the support of non-3GPP ANs, when compared to the previously introduced architecture configurations. The main changes are in the P-GW, PCRF and HSS, and also in S-GW for the chained S8 and S2a/S2b scenario. In addition, completely new elements, such as the EPDG (Evolved Packet Data Gateway) and the AAA are introduced. The AAA infrastructure contains the AAA Server, and it may also contain separate AAA proxies in roaming situations. Figure 3.16 highlights the AAA connections and functions for non-3GPP ANs.

The P-GW is the mobility anchor for the non-3GPP ANs. For PMIP based S2a and S2b interfaces, the P-GW hosts the Local Mobility Anchor (LMA) function in a manner similar to that for the S5/S8 PMIP interfaces. Also the Home Agent (HA) function for the Client MIPv4 Foreign Agent mode in S2a is located in P-GW. The relation between P-GWs and non-3GPP ANs is many to many. The P-GW will also interface with the AAA Server, which subsequently connects to HSS. This interface is used for reporting the selected P-GW to the HSS so that it is available in mobility between non-3GPP ANs, and to authenticate and authorize users connecting with S2c mode. Each P-GW may connect to more than one AAA server.

The PCRF supports PCC interfaces for non-3GPP ANs. The Gxa is used towards trusted non-3GPP ANs, and Gxb towards un-trusted non-3GPP ANs. Only Gxa is specified in detail level

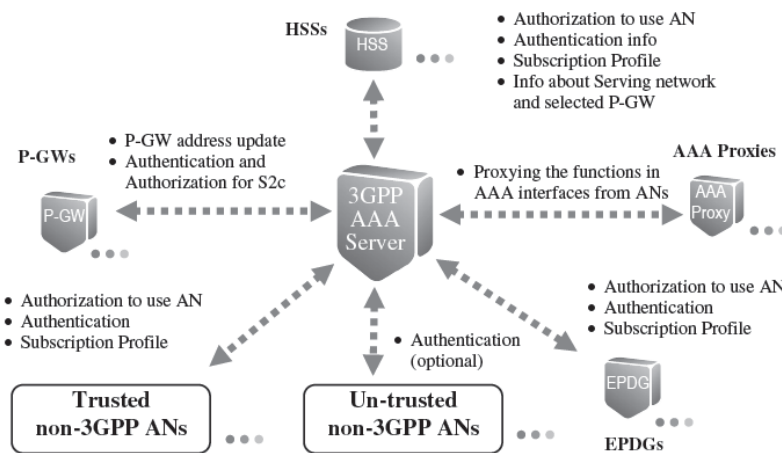

Figure 3.16 3GPP AAA server interfaces and main functions

in Release 8. The Gxa interface functions in a fashion similar to that of the Gxc interface. In this case the BBERF function will be in the non-3GPP AN, and it will receive instructions from the PCRF on how to handle the bearer level functions for the IP flows in the S2a interface. The further bearer functions internal to non-3GPP ANs are not addressed in 3GPP specifications.

The EPDG is a dedicated node for controlling the UE and inter-network connection, when an un-trusted non-3GPP AN is connected to EPC. Since the AN is not trusted, the main function is to secure the connection, as defined in [23]. The EPDG establishes an IPsec tunnel to the UE through the un-trusted non-3GPP AN with IKEv2 signalling [26] over the SWu interface. During the same signalling transaction the EAP-AKA authentication is run, and for that the EPDG signals with the AAA Server through the SWm interface. While the SWm interface is logically between UE and the EPDG, the SWn interface represents the interface on a lower layer between the EPDG and the un-trusted non-3GPP AN. The Release 8 specifications do not assume that EPDG would signal with PCRF for any PCC functions, but the architecture already contains the Gxb interface for that purpose.

The 3GPP AAA Server, and possibly a AAA Proxy in the visited network, performs a 3GPP defined set of AAA functions. These functions are a subset of what the standard IETF defined AAA infrastructure includes, and do not necessarily map with the way other networks use AAA infrastructure. The AAA Server acts between the ANs and the HSS, and in doing so it creates a context for the UEs it serves, and may store some of their information for further use. Thus, the 3GPP AAA Server consolidates the signalling from different types of ANs into a single SWx interface towards the HSS, and terminates the access specific interfaces S6b, S7a, SWm and SWa. Most importantly the AAA Server performs as the authenticator for the EAP-AKA authentication through the non-3GPP ANs. It checks the authenticity of the user, and informs the AN about the outcome. The authorization to use the AN in question will also be performed during this step. Depending on the AN type in question, the AAA Server may also relay subscription profile information to the AN, which the AN may further use to better serve the UE. When the UE is no longer served by a given non-3GPP AN, the AAA Server participates in removing the UE's association from the HSS. Figure 3.16 summarizes the AAA Server main functions in relation to other nodes.

The HSS performs functions similar to those for the 3GPP ANs. It stores the main copy of the subscription profile as well as the secret security key in the AuC portion of it, and when requested, it provides the profile data and authentication vectors to be used in UEs connecting through non-3GPP ANs. One addition compared to 3GPP ANs is that since the non-3GPP ANs do not interface on the AN level, the selected P-GW needs to be stored in the HSS, and retrieved from there when the UE mobility involves a non-3GPP AN. The variety of different AN types are mostly hidden from the HSS, since the AAA Server terminates the interfaces that are specific to them, and HSS only sees a single SWx interface. On the other hand, the subscription profile stored in the HSS must reflect the needs of all the different types of ANs that are valid for that operator.

3.4.3 Interfaces and Protocols in Non-3GPP Inter-working System Architecture Configuration

Connecting the non-3GPP ANs to EPC and operating them with it requires additional interfaces to those introduced in earlier sections. Table 3.4 lists the new interfaces.

Table 3.4 Summary of additional interfaces and protocols in non-3GPP Inter-working System Architecture configuration

Interface	Protocols	Specification
S2a	PMIP/IP, or MIPv4/UDP/IP	29.275 [10]
S2b	PMIP/IP	29.275 [10]
S2c	DSMIPv6, IKEv2	24.303 [27]
S6b	Diameter/SCTP/IP	29.273 [28]
Gxa	Diameter/SCTP/IP	29.212 [13]
Gxb	<i>Not defined in Release 8</i>	<i>N.A.</i>
STa	Diameter/SCTP/IP	29.273 [28]
SWa	Diameter/SCTP/IP	29.273 [28]
SWd	Diameter/SCTP/IP	29.273 [28]
SWm	Diameter/SCTP/IP	29.273 [28]
SWn	PMIP	29.275 [10]
SWu	IKEv2, MOBIKE	24.302 [29]
SWx	Diameter/SCTP/IP	29.273 [28]
UE – foreign agent in trusted non-3GPP Access	MIPv4	24.304 [30]
UE – Trusted or Un-trusted non-3GPP access	EAP-AKA	24.302 [29]

3.4.4 Roaming in Non-3GPP Inter-working System Architecture Configuration

The principles for roaming with non-3GPP accesses are equivalent to those described in section 3.2.4 for 3GPP ANs. Both home routed and local breakout scenarios are supported and the main variations in the architecture relate to the PCC arrangement, which depends on where the services are consumed. This aspect is highlighted more in section 3.7.1.

The additional consideration that non-3GPP ANs bring to roaming is related to the case where the user is roaming to a visited 3GPP network in Home Routed model, and it would be beneficial to use a local non-3GPP AN that is affiliated with the visited network, but there is no association between that network and the home operator. For this scenario, the 3GPP Release 8 includes a so-called *chained case*, where the S-GW may behave as the anchor for the non-3GPP ANs also, i.e. it terminates the S2a or S2b interface, and routes the traffic via the S8 interface to the P-GW in the home network.

3.5 Inter-working with cdma2000® Access Networks

3.5.1 Architecture for cdma2000® HRPD Inter-working

The best inter-working performance in terms of handover gap time is achieved by specifying the networks to inter-operate very tightly to exchange critical information. This creates a specific solution that is valid for only the ANs in question. With the limited time and resources available for specification work, the number of such solutions in 3GPP Release 8 could only be limited. A tight inter-working solution also requires changes in the other ANs, and by definition the development of non-3GPP ANs is not within the control of 3GPP. Achieving a well designed solution requires special attention to coordination between the developments in

different standardization bodies. With these difficulties at hand, 3GPP Release 8 only includes an optimized inter-working solution with cdma2000® HRPD AN.

Figure 3.17 highlights the architecture for cdma2000® HRPD inter-working. It shows the Evolved HRPD (E-HRPD) network, where a number of modifications have been applied to make it suitable for connecting to the EPC. Due to these modifications it will be called E-HRPD in this chapter to distinguish it from legacy HRPD systems that do not support these functions. The radio interface and the Radio Access Network have been kept as similar as possible, but the HRPD Serving Gateway (HSGW) is a completely new node inheriting many of its functions from S-GW.

The E-HRPD is generally treated as a trusted non-3GPP AN, and it is therefore connected to the EPC via S2a, Gxa and STa interfaces. These interfaces operate as described earlier. Since the inter-working solution is optimized, and does not rely on UE performing the attach

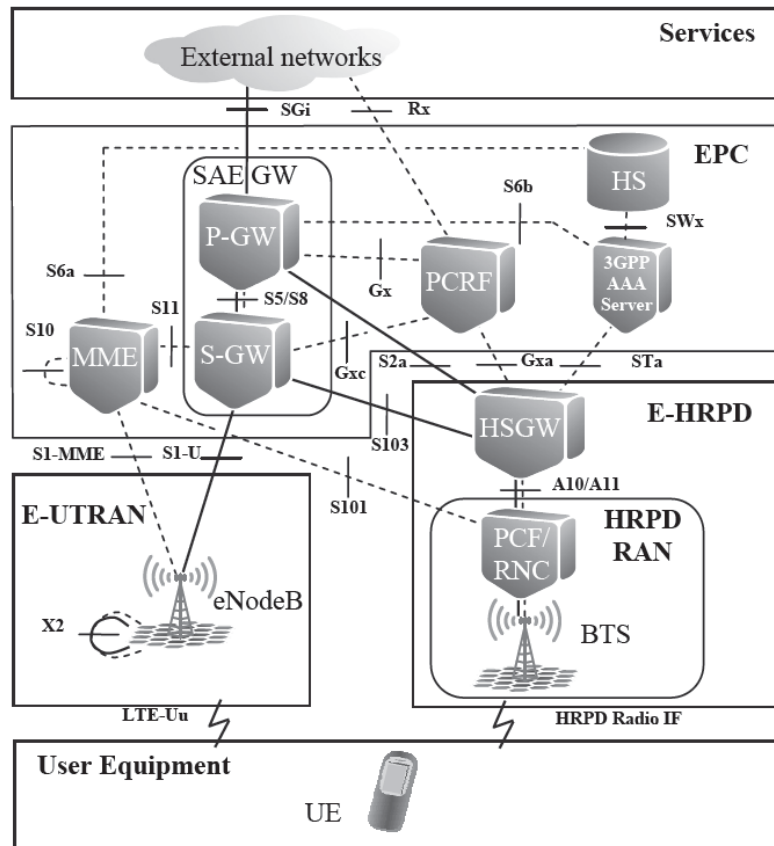

Figure 3.17 System architecture for 3GPP and cdma2000® HRPD inter-working

procedure directly to the target network, two new interfaces, S101 and S103, were defined for the CP and UP interactions respectively.

3GPP ANs and the 3GPP2-defined cdma2000® ANs share many things in common, but many things are also different. Both systems use a prepared handover, where the source system signals to the target system to give it essential parameters to be able to serve the terminal there, and the target system gives the source system parameters that can be further given to the terminal to guide it to make the access to the target radio. While there are similarities in these methods, the parameters themselves do not match well at all, and this method could not be used by applying a simple protocol conversion. To ease up on the need to align every information element that would need to be exchanged in handover, it was decided to use a transparent signalling transport method.

Figure 3.18 shows how the transparent tunnel is used in mobility from E-UTRAN to E-HRPD on the left, and the opposite direction is shown on the right. The thick black arrow indicates the signalling which is carried transparently through the source access system and over the S101 interface to the target system. In this method the source access system gives guidance to the UE to register to the target system through the tunnel. This creates the UE context in the target system without the source system having to convert its information to the target system format. This is called pre-registration, and the purpose is to take the time consuming registration/attach function away from the time critical path of handover. The transparent tunnel may also be used to build the bearer context in the target system so that when the time to make the handover is at hand, everything will be ready and waiting at the target side. The actual handover is decided based on radio interface conditions, and this solution requires that both systems are able to handle measurements from the other system. The following inter-working scenarios are supported between E-UTRAN and E-HRPD:

- E-UTRAN → E-HRPD handover: The pre-registration may be performed well before the actual handover takes place, and also all bearers are set up in the E-HRPD side. The UE remains in a dormant state (equal to idle mode) from the E-HRPD system point of view before handover, and this state may be long lived. When the radio conditions indicate the need for handover, the eNodeB commands the UE to start requesting traffic channel from E-HRPD. This takes place through the transparent tunnel, and once it is completed, the eNodeB commands the UE to make the actual handover. The S103 interface is used only

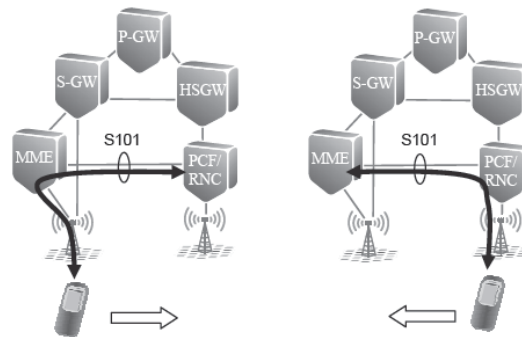

Figure 3.18 Tunnelled pre-registration to eHRPD and to E-UTRAN

in this handover scenario to forward DL data during the time when the UE is making the switch between the radios.

- E-UTRAN → E-HRPD idle mode mobility: The pre-registration state works as described above for the handover. The UE is in idle mode in the E-UTRAN also, and it moves within the system, selecting the cells on its own, and when it selects an E-HRPD cell, it briefly connects to the E-HRPD network to get the mobility pointers updated to the E-HRPD side.
- E-HRPD → E-UTRAN handover: The E-HRPD AN will request the UE to make tunnelled pre-registration (attach) only at the time the handover is needed, and the UE will immediately proceed to requesting connection directly from the E-UTRAN cell after the registration is complete. The bearers are set up in embedded fashion with the registration and connection request procedures.
- E-HRPD → E-UTRAN idle mode mobility: The idle mode procedure follows the same guidelines as the handover for the tunnelled registration (attach), but the UE accesses the E-UTRAN radio only by reporting its new location (Tracking Area), since there is no need to set up bearers in E-UTRAN for UE in idle mode.

3.5.2 Additional and Updated Logical Elements for cdma2000® HRPD Inter-working

Inter-working with eHRPD in an optimized manner brings a lot of new features in the basic SAE network elements, and introduces few totally new elements in the HRPD side. The UE, eNodeB, MME and S-GW will all be modified to support new functions, and MME and S-GW will also deal with new interfaces. The eHRPD is a new network of its own, and it consists of elements such as Base Station, Radio Network Controller (RNC), Packet Control Function (PCF) and HRPD Serving Gateway (HSGW).

The UE will need to support both radio interfaces. The design of the procedure assumes that UE is capable of single mode operation only. On the other hand, the integration is kept loose enough so that it would be possible to implement terminal with separate chip sets for E-UTRAN and E-HRPD. This means that the UE is not required to make measurements of cells in the other technology in as tightly a timewise controlled manner as is normally seen within a single radio technology. The UE will also need to support the tunnelled signalling operation. The tunnelled signalling itself is the same signalling as the UE would use directly with the other system.

The main new requirement for the eNodeB is that it also needs to be able to control mobility towards the eHRPD access. From the radio interface perspective it does this much in the same manner as with the other 3GPP accesses, by instructing the UE to make measurements of the neighbouring eHRPD cells, and making the handover decision based on this information. On the other hand, the eNodeB does not signal the handover preparation towards the eHRPD, like it would for other handovers in S1 interface. Instead the handover preparation works so that the UE sends traffic channel requests to the eHRPD AN through the transparent tunnel, and the eNodeB is only responsible for marking the uplink messages with appropriate routing information, so that the MME can select the right node in the eHRPD AN, and noting the progress of the handover from the headers of the S1 messages carrying the eHRPD signalling.

The MME implements the new S101 interface towards the eHRPD RAN. For UE originated messages, it needs to be able to route them to the right eHRPD RAN node based on a reference given by the eNodeB. In the reverse direction the messages are identified by the IMSI of

the UE, and the basis that the MME can route them to the right S1 signalling connection. The MME does not need to interpret the eHRPD signalling message contents, but the status of the HO progress is indicated along with those messages that require special action from the MME. For example, at a given point during E-UTRAN → E-HRPD handover, the MME will set up the data forwarding tunnels in the S-GW. The MME also needs to memorize the identity of the E-HRPD AN node that a UE has been signalling with, so that if MME change takes place, the MME can update the S101 context in the HRPD AN node.

The S-GW supports the new S103 interface, which is used for forwarding DL data during the time in handover, when the radio link cannot be used. The forwarding function is similar to the function S-GW has for the E-UTRAN handovers. The difference is that S103 is based on a GRE tunnel, and there will be only one tunnel for each UE in handover, so the S-GW needs to map all GTP tunnels from the S1-U interface to a single GRE tunnel in the S103 interface.

The E-HRPD network is a completely new way to use the existing HRPD radio technology with the SAE, by connecting it to the EPC. Compared to the original HRPD, many changes are caused by the inter-working, and connecting to the EPD requires some new functions, e.g. the support of EAP-AKA authentication. The HSGW is taking the S-GW role for E-HRPD access, and performs much like a S-GW towards the P-GW. The HSGW also includes many CP functions. Towards the eHRPD AN, it behaves like the Packet Data Serving Node (PDSN) in a legacy HRPD network. It also signals with the 3GPP AAA Server to authenticate the UE, and to receive its service profile. The CN aspects of the E-HRPD are specified in [31] and the evolved RAN is documented in [32].

3.5.3 Protocols and Interfaces in cdma2000[®] HRPD Inter-working

The optimized inter-working introduces two new interfaces – S101 and S103 – to the architecture (see Table 3.5). The S2a, Gxc and STa are as described earlier. The following summarizes the new interfaces:

- S101 is a CP interface that in principle forms a signalling tunnel for the eHRPD messages. The CP protocol is S101AP, which is specified in [33]. The S101AP uses the same message structure and coding as the newest version of GTP. The main function is to carry the signalling messages, with the IMSI as a reference and with an additional handover status parameter that is set by either the UE or either one of the networks it signals with. In addition, when the data forwarding tunnel needs to be set up, the address information is also included in S101AP. S101AP also includes a procedure to switch the interface from one MME to another if handover in E-UTRAN causes MME change.
- S103 is a simple GRE tunnel for UP data forwarding in handover. It is only used for DL data in handover from E-UTRAN to E-HRPD. S103 is a UP interface only, and all control information to set up the GRE tunnel is carried in other interfaces. It is specified with S101AP in [33].

Table 3.5 Additional interfaces and protocols for inter-working with cdma2000[®] eHRPD

Interface	Protocols	Specification
S101	S101AP/UDP/IP	29.276 [33]
S103	GRE/IP	29.276 [33]

Table 3.6 Additional interfaces and protocols for inter-working with cdma2000® 1xRTT

Interface	Protocols	Specification
S102	S102 protocol	29.277 [34]
A21	A21 protocol	A.S0008-C [35]

3.5.4 Inter-working with cdma2000® 1xRTT

The cdma2000® 1xRTT is a system supporting CS bearers, and is primarily used for voice calls. In this respect it is functionally equivalent to the legacy 3GPP CS infrastructure such as the MSC and the CS bearer capabilities of GERAN and UTRAN. As described in Chapter 10, the 3GPP standard includes two functions to support inter-working between the E-UTRAN and the legacy CS infrastructure. These are the CSFB [19] and SR-VCC [20]. These functions have been extended to cover inter-working with cdma2000® 1xRTT also, and at a high level they work in the same way as described in Chapter 10. In the 1xRTT case, the interface between MME and the cdma2000® 1xRTT infrastructure is called S102. S102 carries a protocol specified in 3GPP2 for the A21 interface, which is used in cdma2000® systems for voice call continuity (see Table 3.6).

3.6 IMS Architecture

3.6.1 Overview

The IP Multimedia Services Sub-System (IMS) is the preferred service machinery for LTE/SAE. IMS was first introduced in Release 5, and with the well defined inter-working with existing networks and services that have been introduced since, the Rel-8 IMS can now be used to provide services over fixed and wireless accesses alike. The IMS architecture is defined in [36], and the functionality is defined in [37]. A comprehensive description of IMS can also be found in [3]. For the purpose of this book, the functional architecture of IMS is presented in Figure 3.19, and a short description of the main functions follows below.

IMS is an overlay service layer on top of the IP connectivity layer that the EPS provides. Figure 3.19 shows a thick grey line from UE to P-GW that represents the UE's IP connectivity to IMS and other external networks through the RAN and EPC. The signalling interfaces Gm and Ut run on top of this connection, which typically use the default bearer a UE will always have in LTE/SAE. The services may further require that dedicated bearers are set up through EPC, and the service data flows may need to be handled by one of the Inter-working or Services Elements.

In principle the IMS is independent of the connectivity layer, which requires its own registration and session management procedures, but it has also been specifically designed to operate over the 3GPP-defined ANs, and it works seamlessly with the PCC described in section 3.7. IMS uses SIP protocol for registration and for controlling the service sessions. SIP is used both between the terminal and the IMS (Gm Interface) and between various IMS nodes (ISC, Mw, Mg, Mr, Mi, Mj, Mx, Mk and Mm Interfaces). The SIP usage in IMS is defined in [38]. Diameter (Cx, Dx, Dh and Sh Interfaces) and H.248 (Mp) are the other protocols used in IMS.

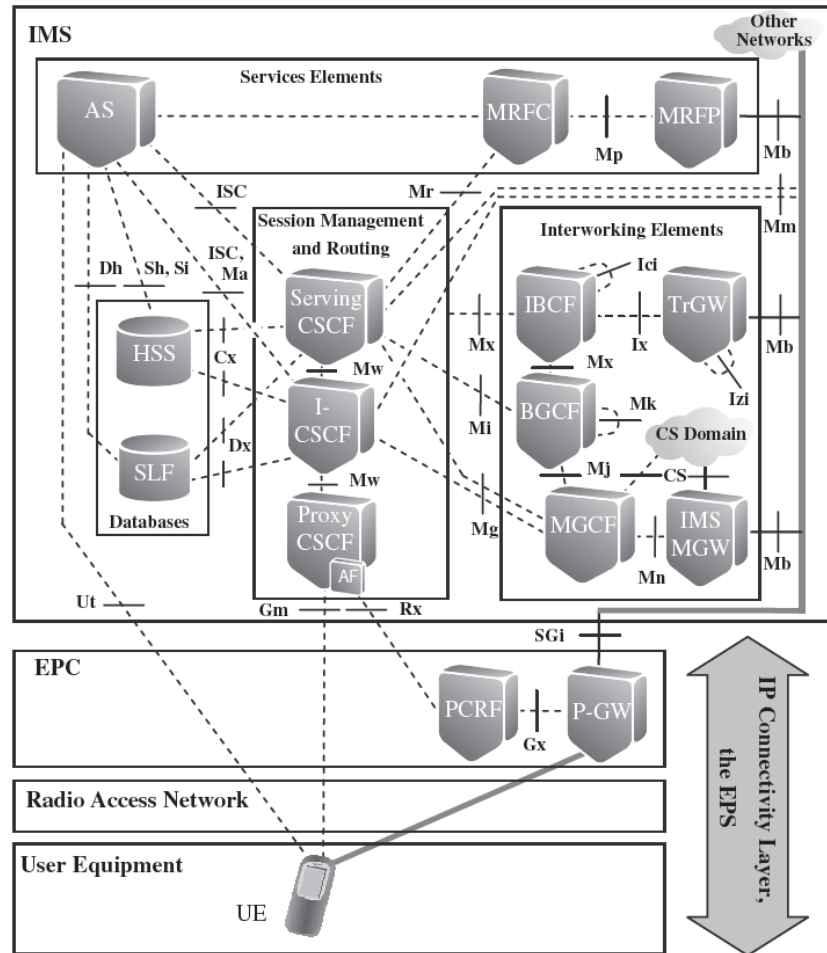

Figure 3.19 IMS architecture

The UE primarily signals with the CSCFs for the services it wishes to use, and in addition some service specific signalling may be run directly with the Application Servers. The signalling may also be network originated for terminating services. The *Session Management and Routing* functions are handled by the CSCFs that are in control of the UE's registration in IMS. For that purpose they signal with the *Databases* to get the appropriate information. The CSCFs are also in control of the UE's service sessions in IMS, and for that purpose they may need to signal with one or more of the *Services Elements* to know what kind of connectivity is needed for the service in question, and then with the connectivity layer through the Rx interface to make corresponding requests to bearer resources. Finally, the CSCFs may need to signal with

one or more of the *Inter-working Elements* to control the interconnection between networks. Whenever the UP flow is routed through one of the IMS elements, it is done through the Mb interface that connects IMS to IP networks. The following sections introduce the main functions in the functional groups highlighted in Figure 3.19.

Most IMS elements responsible for session management and routing or inter-working are involved in collecting charging information. Rf and Ro interfaces are the main IMS charging interfaces (see section 3.7.1). For simplicity, charging related nodes and interfaces are not shown in Figure 3.19.

3.6.2 Session Management and Routing

The Call State Control Function (CSCF) is the central element in SIP signalling between the UE and the IMS, and it takes care of the UE's registration to the IMS, and service session management. The registration includes authentication. The primary authentication method is IMS-AKA [39], but other methods such as http digest [40] may also be used. CSCF is defined to have three different roles that may reside in the same node, or separate nodes connected through the Mw interface, and all are involved in the UE-related SIP signalling transactions:

- The Serving CSCF (S-CSCF) locates in the user's home network, and it will maintain the user's registration and session state. At registration, it interfaces with the HSS to receive the subscription profile, including authentication information, and it will authenticate the UE. For the service sessions, the S-CSCF signals with the UE through the other CSCFs, and may also interact with the Application Servers (ASs) or the MRFCs for setting up the service session properly. It also carries the main responsibility for controlling the Inter-working Elements. The S-CSCF may also need to interact with MGCF for inter-working with CS networks, or with other multimedia networks for UE requested services.
- The Interrogating CSCF (I-CSCF) is located at the border of the home network, and it is responsible for finding out the UE's registration status, and either assigning a new S-CSCF or routing to the right existing S-CSCF. The request may come from Proxy CSCF (P-CSCF), from other multimedia networks, or from CS networks through the Media Gateway Control Function (MGCF). Also I-CSCF may need to interact with the ASs for service handling. The Ma interface is used for this when Public Service Identity (PSI) is used to identify the service, and the I-CSCF can route the request directly to the proper AS.
- The (P-CSCF) is the closest IMS node the UE interacts with, and it is responsible for all functions related to controlling the IP connectivity layer, i.e. the EPS. For this purpose the P-CSCF contains the Application Function (AF) that is a logical element for the PCC concept, which is described in section 3.7.1. The P-CSCF is typically located in the same network as the EPS, but the Rel-8 includes a so-called Local Breakout concept that allows P-CSCF to remain in the home network, while PCRF in the visited network may still be used.

In addition to the above-mentioned three CSCF roles, a fourth role, the Emergency CSCF (E-CSCF), has been defined. As the name indicates, the E-CSCF is dedicated to handling the emergency call service in IMS. The E-CSCF connects to the P-CSCF via the Mw interface, and these nodes must always be in the same network. In addition, the E-CSCF is also connected to a Location Retrieval Function (LRF) through the Mi Interface. The LRF can provide

the location of the UE, and routing information to route the emergency call appropriately. The E-CSCF and LRF are not shown in Figure 3.19 for simplicity

The CSCFs are connected to each other with the Mw interface, and to other multimedia networks through the Mm interface. Interconnection between CSCFs in different operators' networks may be routed through a common point called the Interconnection Border Control Function (IBCF). See section 3.6.5.

3.6.3 Databases

The Home Subscriber Server (HSS) is the main database used by the IMS. The HSS contains the master copy of subscription data, and it is used in much the same way as with the IP connectivity layer. It provides the location and authentication information based on requests from the I- or S-CSCF, or the AS. The interface between the HSS and the Services Elements will be either Sh or Si depending on the type of services elements. The Sh interface is used in case of SIP or OSA service capability server and the Si when CAMEL based AS is in question.

When there is more than one addressable HSS, another database called the Subscription Locator Function (SLF) may be used to find the right HSS.

3.6.4 Services Elements

The actual service logic is located in the Application Servers (AS). A variety of different services may be provided with different ASs, and the standards do not aim to cover all possible services. Some of the main services are covered in order to facilitate easier inter-working with operators in roaming, and to provide for consistent user experience. One example of a standardized AS is the Telephony Application Server (TAS), which may be used to provide the IMS VoIP service.

The media component of the service can be handled by the Multimedia Resource Function (MRF), which is defined as a separate controller (MRFC) and processor (MRFP). The UP may be routed through MRFP for playing announcements as well as for conferencing and transcoding. For coordination purposes, the MRFC may also be connected to the related AS.

3.6.5 Inter-working Elements

The Inter-working Elements are needed when the IMS interoperates with other networks, such as other IMS networks, or CS networks. The following are the main functions of the standardized inter-working elements:

- The Breakout Gateway Control Function (BGCF) is used when inter-working with CS networks is needed, and it is responsible for selecting where the interconnection will take place. It may select the Media Gateway Control Function (MGCF) if the breakout is to happen in the same network, or it may forward the request to another BGCF in another network. This interaction may be routed through the Interconnection Border Control Function (IBCF).
- The Interconnection Border Control Function (IBCF) is used when interconnection between operators is desired to be routed through defined points, which hide the topology inside the network. The IBCF may be used in interconnection between CSCFs or BGCFs and it is in control of Transition Gateway (TrGW), which is used for the same function in the UP.

Note that the IBCF–TrGW interface is not fully specified in Release 8. The IBCFs and the TrGWs in different operators' networks may be interconnected to each other via the Ici and Izi interfaces respectively, and together they comprise the Inter IMS Network to Network Interface (II-NNI).

- The Media Gateway Control Function (MGCF) and IMS-Media Gateway (IMS-MGW) are the CP and UP nodes for inter-working with the CS networks such as the legacy 3GPP networks with CS domain for GERAN or UTRAN, or for PSTN/ISDN. Both incoming and outgoing IMS VoIP calls are supported with the required signalling inter-working and transcoding between different voice coding schemes. The MGCF works in the control of either the CSCF or BGCF.

3.7 PCC and QoS

3.7.1 PCC

Policy and Charging Control (PCC) has a key role in the way users' services are handled in the Release 8 LTE/SAE system. It provides a way to manage the service related connections in a consistent and controlled way. It determines how bearer resources are allocated for a given service, including how the service flows are partitioned to bearers, what QoS characteristics those bearers will have, and finally, what kind of accounting and charging will be applied. If an operator uses only a very simple QoS model, then a static configuration of these parameters may be sufficient, but Release 8 PCC allows the operator to set these parameters dynamically for each service and even each user separately.

The PCC functions are defined in [5] and the PCC signalling transactions as well as the QoS parameter mapping are defined in [41]. Figure 3.20 shows the PCC functions and interfaces in the basic configuration when PCC is applied in one operator's network.

The primary way to set up service flows in Release 8 is one where the UE first signals the request for the service in the Service Layer, and the Application Function (AF) residing in that layer contacts the Policy and Charging Resource Function (PCRF) for appropriate bearer

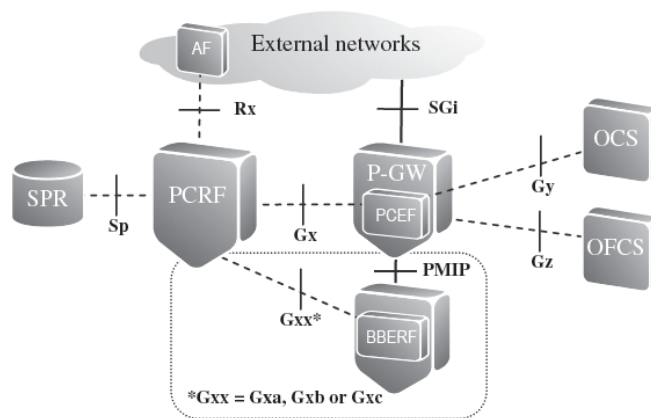

Figure 3.20 Basic PCC functions

resources. The PCRF is in charge for making the decisions on what PCC to use for the service in question. If subscriber specific policies are used, then the PCRF may enquire subscription related policies from the Subscription Profile Repository (SPR). Further details about SPR structure and, for example, its relation to HSS, and the Sp interface are not specified in Release 8. Based on the decision, the PCRF creates the appropriate PCC rules that determine the handling in the EPS.

If the interface from P-GW to the S-GW is based on GTP, the PCRF pushes the PCC rules to the Policy and Charging Enforcement Function (PCEF) residing in the P-GW, and it alone will be responsible for enforcing the PCC rules, e.g. setting up the corresponding dedicated bearers, or modifying the existing bearers so that the new IP service flows can be mapped to them, and by ensuring that only authorized service flows are allowed and QoS limits are not exceeded. In this case the Gxx interface shown in Figure 3.20 does not apply.

If the interface from P-GW towards the AN is based on PMIP, i.e. if it is S5 PMIP, S2a or S2b, there is no means to signal the bearer level information onwards from the P-GW, and the PCRF will create a separate set of QoS rules, and those are first sent to the BBERF, which will handle the mapping between IP service flows and bearers over the AN. Depending on the AN type, the BBERF may reside in S-GW (S5 PMIP), trusted non-3GPP AN, e.g. in HSGW (S2a), or in the EPDG (S2b) for the un-trusted non-3GPP AN (S2b is not supported in Release 8). Also in this case the PCC rules are also sent to PCEF in the P-GW, and it performs the service flow and QoS enforcement.

Release 8 also supports UE initiated bearer activation within the EPS, which is applicable to the case when there is no defined service that both the UE and the serving network could address. In this case the UE signals with the AN and the BBERF requests the service resources from the PCRF. The PCRF makes the PCC decision, and the logic then continues as described above.

The PCC standard [5] defines two charging interfaces, Gy and Gz, which are used for online and offline charging respectively. The Gy interface connects the PCEF to the Online Charging System (OCS), which is used for flow based charging information transfer and control in an online fashion. The Gz interface is used between the P-GW and the Offline Charging System (OFCS), and it is applied when charging records are consolidated in an offline fashion. The charging specifications [42] and [43] further define that the Gy interface is functionally equivalent to the Ro interface that uses Diameter Credit-Control Application as defined in [44]. The Gz interface may be based on either the Rf interface, which relies on the mentioned Diameter Credit-Control Application, or the Ga interface, which uses the 3GPP defined GTP protocol. The Ro and Rf interfaces are also used for charging in IMS, and were originally specified for that purpose.

The PCRF in control of the PCEF/P-GW and the BBERF typically reside in the same operator's network. In the case of roaming, they may reside in different networks, and the S9 interface between PCRFs is used to enable the use of a local PCRF. The S9 interface is defined in [9], and it re-uses the applicable parts from Rx, Gx and Gxx interfaces to convey the information between the PCRFs.

There are two different cases when the S9 interface is used. The first case, which is shown in Figure 3.21, applies when the roaming interface is based on PMIP, and the PCEF and BBERF are in different networks. In this scenario traffic is routed to the home network. In the second case, shown in Figure 3.22, the Local Breakout model is applied, and the P-GW resides in the visited network. The AF and Rx interface will be used from the same network that provides the service in question. The OCS will reside in the home network. As described

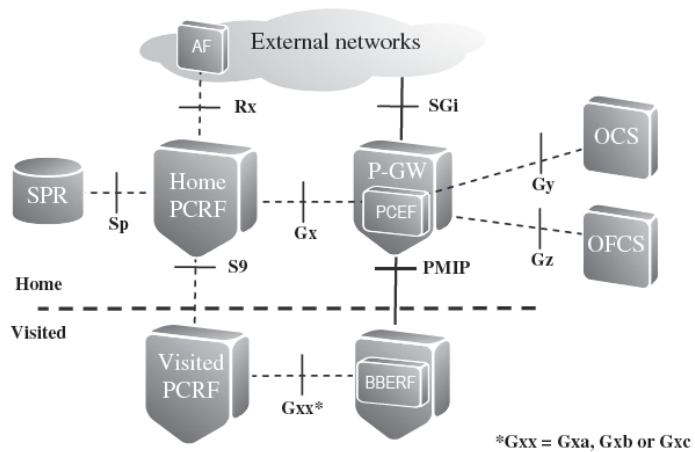

Figure 3.21 PCC functions in roaming with PMIP, home routed model

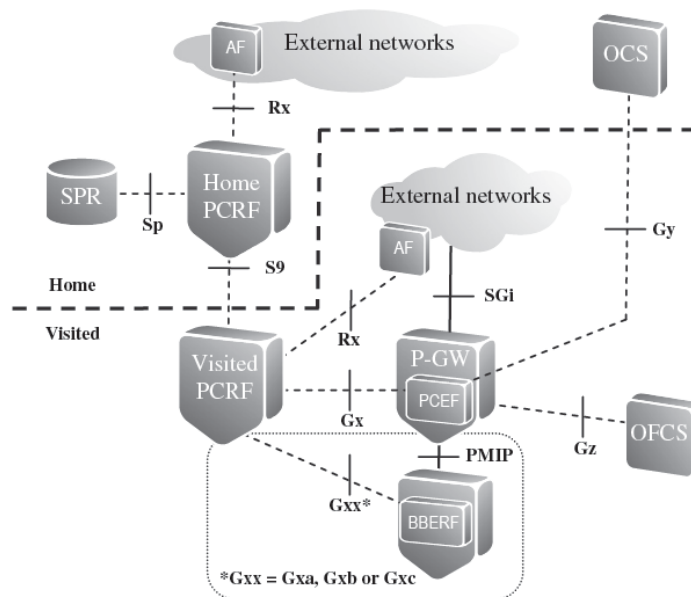

Figure 3.22 PCC functions in roaming, local breakout model

above, the separate BBERF and Gxx interfaces apply only if PMIP is used from the P-GW in the visited network.

Table 3.7 lists the PCC related interfaces and the protocols, and the standards where they are specified.

Table 3.7 Summary of PCC interfaces

Interface	Protocols	Specification
Gx	Diameter/SCTP/IP	29.212 [13]
Gxx (Gxa or Gxc)	Diameter/SCTP/IP	29.212 [13]
Rx	Diameter/SCTP/IP	29.214 [14]
S9	Diameter/SCTP/IP	29.215 [45]
Sp	<i>Not defined in Release 8</i>	<i>N.A.</i>
Gy =		32.240 [42]
Ro	Diameter/SCTP/IP	32.299 [46]
Gz =		32.251 [43]
Rf or	Diameter/SCTP/IP or	32.295 [47] or
Ga	GTP'/UDP or TCP/IP	32.299 [46]

3.7.2 QoS

The development of the SAE bearer model and the QoS concept started with the assumption that improvements compared to the existing 3GPP systems with, e.g. UTRAN access, should be made, and the existing model should not be taken for granted. Some potential areas had already been identified. It had not been easy for the operators to use QoS in the legacy 3GPP systems. An extensive set of QoS attributes was available, but it was to some extent disconnected from the application layer, and thus it had not been easy to configure the attributes in the correct way. This problem was emphasized by the fact that the UE was responsible for setting the QoS attributes for a bearer. Also, the bearer model had many layers, each signalling just about the same information. It was therefore agreed that for SAE, only a reduced set of QoS parameters and standardized characteristics would be specified. Also it was decided to turn the bearer set-up logic so that the network resource management is solely network controlled, and the network decides how the parameters are set, and the main bearer set-up logic consists of only one signalling transaction from the network to the UE and all interim network elements.

The resulting SAE bearer model is shown in Figure 3.23. The bearer model itself is very similar to the GPRS bearer model, but it has fewer layers. EPS supports the always-on concept.

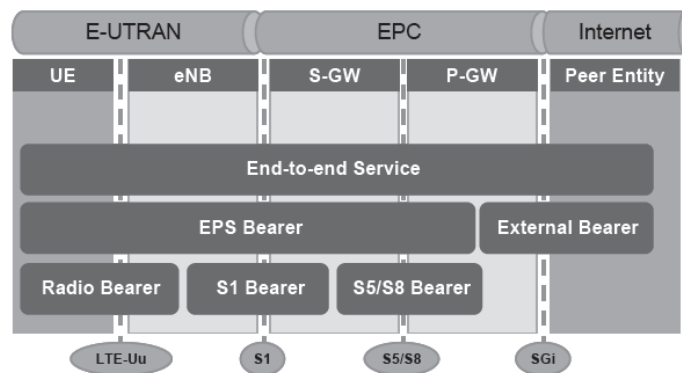
**Figure 3.23** SAE Bearer model

Each UE that is registered to the system has at least one bearer called the default bearer available, so that continuous IP connectivity is provided. The default bearer may have quite basic QoS capabilities, but additional bearers may be set up on demand for services that need more stringent QoS. These are called dedicated bearers. The network may also map several IP flows that have matching QoS characteristics to the same EPS bearer.

The bearer set-up logic works so that the UE first signals on the application layer, on top of the default bearer, to an Application Server (AS) in the operator service cloud, e.g. with IMS, to set up the End-to-end Service. This signalling may include QoS parameters, or simply indication to a known service. The AS will then request the set-up of the corresponding EPS bearer through the PCC infrastructure. There is no separate signalling transaction for the EPS bearer layer, but the EPS bearer is set up together with the signalling for the lower layers, i.e. S5/S8 bearer, S1 Bearer and Radio Bearer. Furthermore, since the eNodeB is responsible for controlling the radio interface transmission in the uplink as well, the UE can operate based on very basic QoS information. The overall goal for network orientation in bearer set-up is to minimize the need for QoS knowledge and configuration in the UE.

Also the QoS parameters were optimized for SAE. Only a limited set of signalled QoS parameters are included in the specifications. They are:

- QoS Class Identifier (QCI): It is an index that identifies a set of locally configured values for three QoS attributes: Priority, Delay and Loss Rate. QCI is signalled instead of the values of these parameters. Ten pre-configured classes have been specified in two categories of bearers, Guaranteed Bit Rate (GBR) and Non-Guaranteed Bit-Rate (Non-GBR) bearers. In addition operators can create their own classes that apply within their network. The standard QCI classes and the values for the parameters within the class are shown in Table 3.8.
- Allocation and Retention Priority (ARP): Indicates the priority of the bearer compared to other bearers. This provides the basis for admission control in bearer set-up, and further in a congestion situation if bearers need to be dropped.
- Maximum Bit Rate (MBR): Identifies the maximum bit rate for the bearer. Note that a Release 8 network is not required to support differentiation between the MBR and GBR, and the MBR value is always set to equal to the GBR.
- Guaranteed Bit Rate (GBR): Identifies the bit rate that will be guaranteed to the bearer.
- Aggregate Maximum Bit Rate (AMBR): Many IP flows may be mapped to the same bearer, and this parameter indicates the total maximum bit rate a UE may have for all bearers in the same PDN connection.

Table 3.8 QoS parameters for QCI

QCI	Resource type	Priority	Delay budget	Loss rate	Example application
1	GBR	2	100 ms	1e-2	VoIP
2	GBR	4	150 ms	1e-3	Video call
3	GBR	5	300 ms	1e-6	Streaming
4	GBR	3	50 ms	1e-3	Real time gaming
5	Non-GBR	1	100 ms	1e-6	IMS signalling
6	Non-GBR	7	100 ms	1e-3	Interactive gaming
7	Non-GBR	6	300 ms	1e-6	Application with TCP:
8	Non-GBR	8			browsing, email, file
9	Non-GBR	9			download, etc.

Table 3.8 shows the QoS parameters that are part of the QCI class, and the nine standardized classes. The QoS parameters are:

- Resource Type: Indicates which classes will have GBR associated to them.
- Priority: Used to define the priority for the packet scheduling of the radio interface.
- Delay Budget: Helps the packet scheduler to maintain sufficient scheduling rate to meet the delay requirements for the bearer.
- Loss Rate: Helps to use appropriate RLC settings, e.g. number of re-transmissions.

References

- [1] 3GPP TS 23.401, 'General Packet Radio Service (GPRS) enhancements for Evolved Universal Terrestrial Radio Access Network (E-UTRAN) access (Release 8)'.
- [2] 3GPP TS 23.402, 'Architecture enhancements for non-3GPP accesses (Release 8)'.
- [3] M. Poikselkä et al., 'The IMS: IP Multimedia Concepts and Services', 2nd edition, Wiley, 2006.
- [4] 3GPP TS 33.401, 'Security Architecture (Release 8)'.
- [5] 3GPP TS 23.203, 'Policy and charging control architecture (Release 8)'.
- [6] 3GPP TS 36.413, 'Evolved Universal Terrestrial Radio Access (E-UTRA) and Evolved Universal Terrestrial Radio Access Network (E-UTRAN); Overall description (Release 8)'.
- [7] 3GPP TS 36.423, 'Evolved Universal Terrestrial Radio Access Network (E-UTRAN); X2 Application Protocol (X2AP) (Release 8)'.
- [8] 3GPP TS 29.274, 'Evolved GPRS Tunnelling Protocol (eGTP) for EPS (Release 8)'.
- [9] 3GPP TS 36.413, 'Evolved Universal Terrestrial Radio Access (E-UTRA); S1 Application Protocol (S1AP) (Release 8)'.
- [10] 3GPP TS 29.275, 'PMIP based Mobility and Tunnelling protocols (Release 8)'.
- [11] 3GPP TS 29.061, 'Inter-working between the Public Land Mobile Network (PLMN) supporting packet based services and Packet Data Networks (PDN) (Release 8)'.
- [12] 3GPP TS 29.272, 'MME Related Interfaces Based on Diameter Protocol (Release 8)'.
- [13] 3GPP TS 29.212, 'Policy and charging control over Gx reference point (Release 8)'.
- [14] 3GPP TS 29.214, 'Policy and charging control over Rx reference point (Release 8)'.
- [15] 3GPP TS 24.301, 'Non-Access-Stratum (NAS) protocol for Evolved Packet System (EPS) (Release 8)'.
- [16] H. Holma, A. Toskala, 'WCDMA for UMTS – HSPA Evolution and LTE', 4th edition, Wiley, 2007.
- [17] T. Halonen, J. Romero, J. Melero, 'GSM, GPRS and EDGE Performance: Evolution Towards 3G/UMTS', 2nd edition, Wiley, 2003.
- [18] 3GPP TS 23.060, 'General Packet Radio Service (GPRS); Service description; Stage 2 (Release 8)'.
- [19] 3GPP TS 23.272, 'Circuit Switched (CS) fallback in Evolved Packet System (EPS); Stage 2 (Release 8)'.
- [20] 3GPP TS 23.216, 'Single Radio Voice Call Continuity (SRVCC); Stage 2 (Release 8)'.
- [21] 3GPP TS 29.118, 'Mobility Management Entity (MME) – Visitor Location Register (VLR) S-Gs interface specification (Release 8)'.
- [22] 3GPP TS 29.280, '3GPP EPS Sv interface (MME to MSC) for SRVCC (Release 8)'.
- [23] 3GPP TS 33.402, 'Security aspects of non-3GPP accesses (Release 8)'.
- [24] IETF Internet-Draft, draft-arkko-eap-aka-kdf, 'Improved Extensible Authentication Protocol Method for 3rd Generation Authentication and Key Agreement (EAP-AKA)'. (J. Arkko, V. Lehtovirta, P. Eronen) 2008.
- [25] 3GPP TS 23.234, '3GPP system to Wireless Local Area Network (WLAN) interworking; System description (Release 7)'.
- [26] IETF RFC 4306, 'Internet Key Exchange (IKEv2) Protocol.' C. Kaufman, Editor, 2005.
- [27] 3GPP TS 24.303, 'Mobility management based on Dual-Stack Mobile IPv6 (Release 8)'.
- [28] 3GPP TS 29.273, 'Evolved Packet System (EPS); 3GPP EPS AAA interfaces (Release 8)'.
- [29] 3GPP TS 24.302, 'Access to the Evolved Packet Core (EPC) via non-3GPP access networks (Release 8)'.
- [30] 3GPP TS 24.304, 'Mobility management based on Mobile IPv4; User Equipment (UE) – foreign agent interface (Release 8)'.
- [31] 3GPP2 Specification X.P0057, 'E-UTRAN – HRPD Connectivity and Interworking: Core Network Aspects (2008)'.

- [32] 3GPP2 Specification X.P0022, 'E-UTRAN – HRPD Connectivity and Interworking: Access Network Aspects (E-UTRAN – HRPD IOS) (2008)'.
- [33] 3GPP TS 29.276, 'Optimized Handover Procedures and Protocols between EUTRAN Access and cdma2000 HRPD Access (Release 8)'.
- [34] 3GPP TS 29.277, 'Optimized Handover Procedures and Protocols between EUTRAN Access and 1xRTT Access (Release 8)'.
- [35] 3GPP2 Specification A.S0008-C, 'Interoperability Specification (IOS) for High Rate Packet Data (HRPD) Radio Access Network Interfaces with Session Control in the Access Network (2007)'.
- [36] 3GPP TS 23.002, 'Network architecture (Release 8)'.
- [37] 3GPP TS 23.228, 'IP Multimedia Subsystem (IMS); Stage 2 (Release 8)'.
- [38] 3GPP TS 24.229, 'IP multimedia call control protocol based on Session Initiation Protocol (SIP) and Session Description Protocol (SDP); Stage 3 (Release 8)'.
- [39] 3GPP TS 33.203, '3G security; Access security for IP-based services (Release 8)'.
- [40] IETF RFC 2617, 'HTTP Authentication: Basic and Digest Access Authentication', J. Franks, P. Hallam-Baker, J. Hostetler, S. Lawrence, P. Leach, A. Luotonen, L. Stewart (1999).
- [41] 3GPP TS 29.213, 'Policy and Charging Control signalling flows and QoS parameter mapping (Release 8)'.
- [42] 3GPP TS 32.240, 'Telecommunication management; Charging management; Charging architecture and principles (Release 8)'.
- [43] 3GPP TS 32.251, 'Telecommunication management; Charging management; Packet Switched (PS) domain charging (Release 8)'.
- [44] IETF RFC 4006, 'Diameter Credit-Control Application', H. Hakala, L. Mattila, J.-P. Koskinen, M. Stura, J. Loughney (2005).
- [45] 3GPP TS 29.215, 'Policy and Charging Control (PCC) over S9 reference point (Release 8)'.
- [46] 3GPP TS 32.299, 'Telecommunication management; Charging management; Diameter charging applications (Release 8)'.
- [47] 3GPP TS 32.295, 'Telecommunication management; Charging management; Charging Data Record (CDR) transfer (Release 8)'.

4

Introduction to OFDMA and SC-FDMA and to MIMO in LTE

Antti Toskala and Timo Lunttila

4.1 Introduction

As discussed in Chapter 1, LTE multiple access is different to that of WCDMA. In LTE the downlink multiple access is based on the Orthogonal Frequency Division Multiple Access (OFDMA) and the uplink multiple access is based on the Single Carrier Frequency Division Multiple Access (SC-FDMA). This chapter will introduce the selection background and the basis for both SC-FDMA and OFDMA operation. The basic principles behind the multi-antenna transmission in LTE, using Multiple Input Multiple Output (MIMO) technology, is also introduced. The intention of this chapter is to illustrate the multiple access principles in a descriptive way without too much mathematics. For those interested in the detailed mathematical notation, two selected references are given that provide a mathematical treatment of the different multiple access technologies, covering both OFDMA and SC-FDMA.

4.2 LTE Multiple Access Background

A Single Carrier (SC) transmission means that information is modulated only to one carrier, adjusting the phase or amplitude of the carrier or both. Frequency could also be adjusted, but in LTE this is not effected. The higher the data rate, the higher the symbol rate in a digital system and thus the bandwidth is higher. With the use of simple Quadrature Amplitude Modulation (QAM), with the principles explained, for example in [1], the transmitter adjusts the signal to carry the desired number of bits per modulation symbol. The resulting spectrum waveform is a single carrier spectrum, as shown in Figure 4.1, with the spectrum mask influenced (after filtering) by the pulse shape used.

With the Frequency Division Multiple Access (FDMA) principle, different users would then be using different carriers or sub-carriers, as shown in Figure 4.2, to access the system simultaneously having their data modulation around a different center frequency. Care must be now

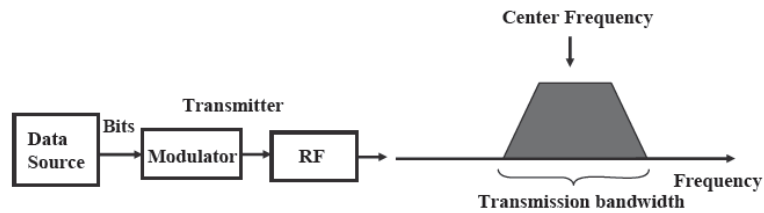

Figure 4.1 Single carrier transmitter

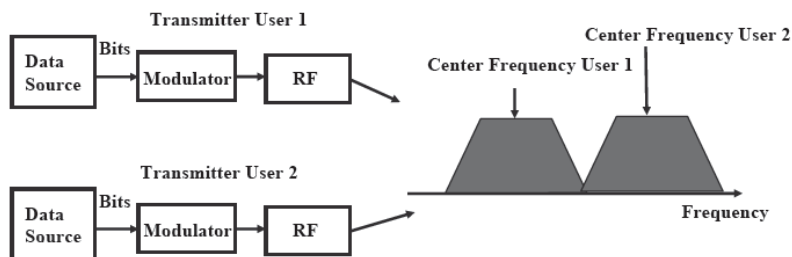

Figure 4.2 FDMA principle

taken to create the waveform in such a way that there is no excessive interference between the carriers, nor should one be required to use extensive guard bands between users.

The use of the multi-carrier principle is shown in Figure 4.3, where data are divided on the different sub-carriers of one transmitter. The example in Figure 4.3 has a filter bank which for practical solutions (such as the ones presented later) is usually replaced with Inverse Fast Fourier Transform (IFFT) for applications where the number of sub-carriers is high. There is a constant spacing between neighboring sub-carriers. One of the approaches to multi-carrier is also the dual carrier WCDMA (dual cell HSDPA, as covered in Chapter 13), which sends two WCDMA next to each other but does not use the principles explained later in this section for high spectrum utilization.

To address the resulting inefficiency from the possible guard band requirements, the approach is to choose the system parameters in such a way as to achieve orthogonality between the dif-

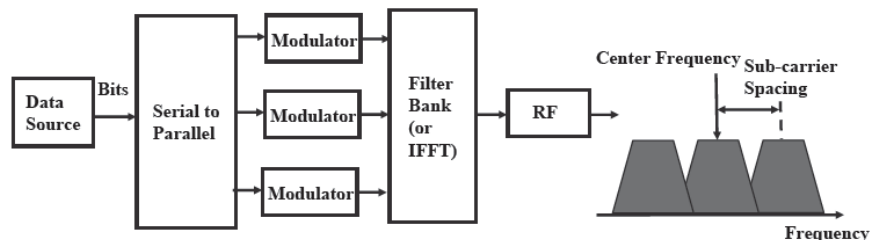

Figure 4.3 Multi-carrier principle

ferent transmissions, and to create the sub-carriers so that they do not interfere with each other but their spectrums could still overlap in the frequency domain. This is what is achieved with the Orthogonal Frequency Division Multiplexing (OFDMA) principle, where each of the center frequencies for the sub-carriers is selected from the set that has such a difference in the frequency domain that the neighboring sub-carriers have zero value at the sampling instant of the desired sub-carrier, as shown in Figure 4.4. For LTE, the constant frequency difference between the sub-carriers has been chosen to be 15 kHz in Release 8 (an alternative of 7.5 kHz is planned to be supported in later releases in connection with broadcast applications such as mobile TV).

The basic principle of OFDMA was already known in the 1950s, at a time when systems were using analog technology, and making the sub-carriers stay orthogonal as a function of component variations and temperature ranges was not a trivial issue. Since the widespread use of digital technology for communications, OFDMA also became more feasible and affordable for consumer use. During recent years OFDMA technology has been widely adopted in many areas such as in digital TV (DVB-T and DVB-H) as well as in Wireless Local Area Network (WLAN) applications.

OFDMA principles have been used in the uplink part of LTE multiple access just as the SC-FDMA uses many of the OFDMA principles in the uplink direction to achieve high spectral efficiency, as described in the next section. The SC-FDMA in the current form, covered in a later section of this chapter, is more novel technology with publications from the late 1990s, such as those presented in [2] and the references therein.

The overall motivation for OFDMA in LTE and in other systems has been due to the following properties:

- good performance in frequency selective fading channels;
- low complexity of base-band receiver;
- good spectral properties and handling of multiple bandwidths;
- link adaptation and frequency domain scheduling;
- compatibility with advanced receiver and antenna technologies.

Many of these benefits (with more explanation provided in the following sections) could only be achieved following the recent developments in the radio access network architecture, meaning setting the radio related control in the base station (or NodeB in 3GPP terms for

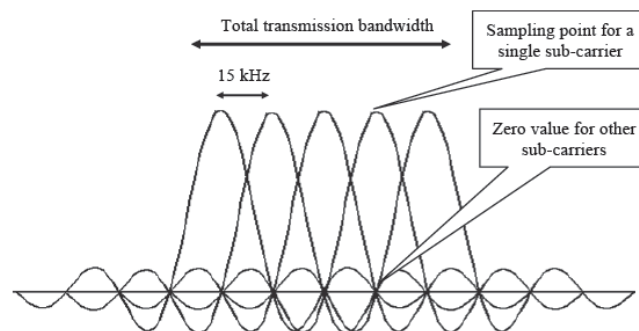

Figure 4.4 Maintaining the sub-carriers' orthogonality

WCDMA), and as the system bandwidths are getting larger, beyond 5 MHz, receiver complexity also becomes more of an issue.

The OFDMA also has challenges, such as:

- Tolerance to frequency offset. This was tackled in LTE design by choosing a sub-carrier spacing of 15 kHz, which gives a large enough tolerance for Doppler shift due to velocity and implementation imperfections.
- The high Peak-to-Average Ratio (PAR) of the transmitted signal, which requires high linearity in the transmitter. The linear amplifiers have a low power conversion efficiency and therefore are not ideal for mobile uplinks. In LTE this was solved by using the SC-FDMA, which enables better power amplifier efficiency.

When looking back, the technology selections carried out for the 3rd generation system in the late 1990s, the lack of a sensible uplink solution, the need for advanced antenna solutions (with more than a single antenna) and having radio resource control centralized in the Radio Network Controller (RNC) were the key factors not to justify the use of OFDMA technology earlier. There were studies to look at the OFDMA together with CDMA in connection with the 3rd generation radio access studies, such as are covered in [3]. The key enabling technologies that make OFDMA work better, such as base station based scheduling (Release 5 and 6) and Multiple Input Multiple Output (MIMO) (Release 7), have been introduced only in the later phase of WCDMA evolution. These enhancements, which were introduced in WCDMA between 2002 and 2007, allowed the OFDMA technology to be better used than would have been the case for the simple use of OFDMA only as a modulation method based on a traditional 2nd generation cellular network without advanced features.

4.3 OFDMA Basics

The practical implementation of an OFDMA system is based on digital technology and more specifically on the use of Discrete Fourier Transform (DFT) and the inverse operation (IDFT) to move between time and frequency domain representation. The resulting signal feeding a sinusoidal wave to the Fast Fourier Transform (FFT) block is illustrated in Figure 4.5. The

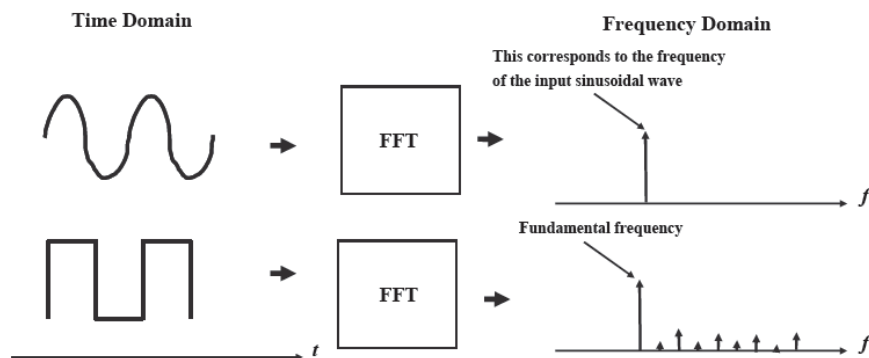

Figure 4.5 Results of the FFT operation with different inputs

practical implementations use the FFT. The FFT operation moves the signal from time domain representation to frequency domain representation. The Inverse Fast Fourier Transform (IFFT) does the operation in the opposite direction. For the sinusoidal wave, the FFT operation's output will have a peak at the corresponding frequency and zero output elsewhere. If the input is a square wave, then the frequency domain output contains peaks at multiple frequencies as such a wave contains several frequencies covered by the FFT operation. An impulse as an input to FFT would have a peak on all frequencies. As the square wave has a regular interval T , there is a bigger peak at the frequency $1/T$ representing the fundamental frequency of the waveform, and a smaller peak at odd harmonics of the fundamental frequency. The FFT operation can be carried out back and forth without losing any of the original information, assuming that the classical requirements for digital signal processing in terms of minimum sampling rates and word lengths (for the numerics) are fulfilled.

The implementation of the FFT is well researched and optimized (low amount of multiplications) when one can stay with power of lengths. Thus for LTE the necessary FFT lengths also tend to be powers of two, such as 512, 1024, etc. From the implementation point of view it is better to have, for example, a FFT size of 1024 even if only 600 outputs are used (see later the discussion on sub-carriers), than try to have another length for FFT between 600 and 1024.

The transmitter principle in any OFDMA system is to use narrow, mutually orthogonal sub-carriers. In LTE the sub-carrier spacing is 15 kHz regardless of the total transmission bandwidth. Different sub-carriers are orthogonal to each other, as at the sampling instant of a single sub-carrier the other sub-carriers have a zero value, as was shown in Figure 4.4. The transmitter of an OFDMA system uses IFFT block to create the signal. The data source feeds to the serial-to-parallel conversion and further to the IFFT block. Each input for the IFFT block corresponds to the input representing a particular sub-carrier (or particular frequency component of the time domain signal) and can be modulated independently of the other sub-carriers. The IFFT block is followed by adding the cyclic extension (cyclic prefix), as shown in Figure 4.6.

The motivation for adding the cyclic extension is to avoid inter-symbol interference. When the transmitter adds a cyclic extension longer than the channel impulse response, the effect of the previous symbol can be avoided by ignoring (removing) the cyclic extension at the receiver.

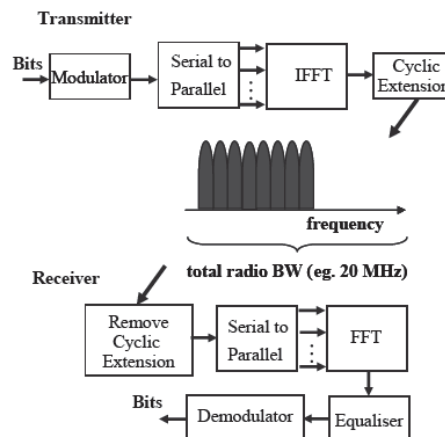

Figure 4.6 OFDMA transmitter and receiver

The cyclic prefix is added by copying part of the symbol at the end and attaching it to the beginning of the symbol, as shown in Figure 4.7. The use of cyclic extension is preferable to simply a break in the transmission (guard interval) as the OFDM symbol then seems to be periodic. When the OFDMA symbol now appears as periodic due to cyclic extension, the impact of the channel ends up corresponding to a multiplication by a scalar, assuming that the cyclic extension is sufficiently long. The periodic nature of the signals also allows for a discrete Fourier spectrum enabling the use of DFT and IDFT in the receiver and transmitter respectively.

Typically the guard interval is designed to be such that it exceeds the delay spread in the environment where the system is intended to be operated. In addition to the channel delay spread, the impact of transmitter and receiver filtering needs to be accounted for in the guard interval design. The OFDMA receiver sees the OFDMA symbol coming as through a FIR filter, without separating individual frequency components like the RAKE receiver as described in [4]. Thus, similar to the channel delay spread, the length of the filter applied to the signal in the receiver and transmitter side will also make this overall ‘filtering’ effect longer than just the delay spread.

While the receiver does not deal with the inter-symbol interference, it still has to deal with the channel impact for the individual sub-carriers that have experienced frequency dependent phase and amplitude changes. This channel estimation is facilitated by having part of the symbols as known reference or pilot symbols. With the proper placement of these symbols in both the time and frequency domains, the receiver can interpolate the effect of the channel to the different sub-carriers from this time and frequency domain reference symbol ‘grid’. An example is shown in Figure 4.8.

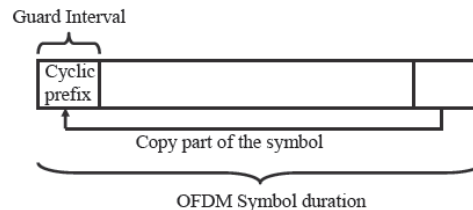

Figure 4.7 Creation of the guard interval for the OFDM symbol

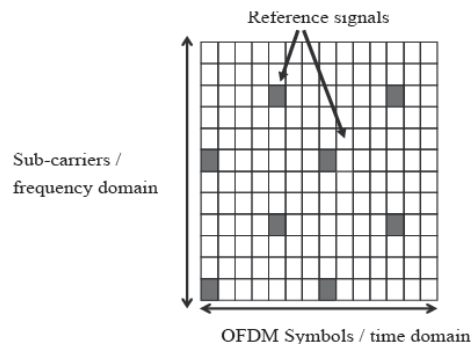

Figure 4.8 Reference symbols spread over OFDMA sub-carriers and symbols

A typical type of receiver solution is the frequency domain equalizer, which basically reverts the channel impact for each sub-carrier. The frequency domain equalizer in OFDMA simply multiplies each sub-carrier (with the complex-valued multiplication) based on the estimated channel frequency response (the phase and amplitude adjustment each sub-carrier has experienced) of the channel. This is clearly a simpler operation compared with WCDMA and is not dependent on channel length (length of multipath in chips) as is the WCDMA equalizer. For WCDMA the challenge would be also to increase the chip rate from the current value of 3.84 Mcps, as then the amount of multi-path components separated would increase (depending on the environment) resulting in the need for more RAKE fingers and contributing heavily to equalizer complexity.

In WCDMA the channel estimation in the downlink is based on the Common Pilot Channel (CPICH) and then on pilot symbols on the Dedicated Channel (DCH), which are transmitted with the spread over the whole transmission bandwidth, and different cells separated by different spreading codes. As in the OFDMA system there is no spreading available, other means must be used to separate the reference symbols between cells or between different antennas. In the multi-antenna transmission, as discussed in further detail later in this chapter, the pilot symbols have different positions. A particular position used for a pilot symbol for one antenna is left unused for other antenna in the same cell. Between different cells this blanking is not used, but different pilot symbol patterns and symbol locations can be used.

The additional tasks that the OFDMA receiver needs to cover are time and frequency synchronization. Synchronization allows the correct frame and OFDMA symbol timing to be obtained so that the correct part of the received signal is dropped (cyclic prefix removal). Time synchronization is typically obtained by correlation with known data samples – based on, for example, the reference symbols – and the actual received data. The frequency synchronization estimates the frequency offset between the transmitter and the receiver and with a good estimate of the frequency offset between the device and base station, the impact can be then compensated both for receiver and transmitter parts. The device locks to the frequency obtained from the base station, as the device oscillator is not as accurate (and expensive) as the one in the base station. The related 3GPP requirements for frequency accuracy are covered in Chapter 11.

Even if in theory the OFDMA transmission has rather good spectral properties, the real transmitter will cause some spreading of the spectrum due to imperfections such as the clipping in the transmitter. Thus the actual OFDMA transmitter needs to have filtering similar to the pulse shape filtering in WCDMA. In the literature this filtering is often referred as windowing, as in the example transmitter shown in Figure 4.9.

An important aspect of the use of OFDMA in a base station transmitter is that users can be allocated basically to any of the sub-carriers in the frequency domain. This is an additional element to the HSDPA scheduler operation, where the allocations were only in the time domain

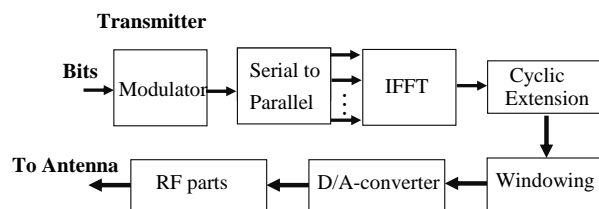

Figure 4.9 OFDMA transmitter with windowing for shaping the spectral mask

and code domain but always occupied the full bandwidth. The possibility of having different sub-carriers to allocated users enables the scheduler to benefit from the diversity in the frequency domain, this diversity being due to the momentary interference and fading differences in different parts of the system bandwidth. The practical limitation is that the signaling resolution due to the resulting overhead has meant that allocation is not done on an individual sub-carrier basis but is based on resource blocks, each consisting of 12 sub-carriers, thus resulting in the minimum bandwidth allocation being 180 kHz. When the respective allocation resolution in the time domain is 1 ms, the downlink transmission resource allocation thus means filling the resource pool with 180 kHz blocks at 1 ms resolution, as shown in Figure 4.10. Note that the resource block in the specifications refers to the 0.5 ms slot, but the resource allocation is done anyway with the 1 ms resolution in the time domain. This element of allocating resources dynamically in the frequency domain is often referred to as frequency domain scheduling or frequency domain diversity. Different sub-carriers could ideally have different modulations if one could adapt the channel without restrictions. For practical reasons it would be far too inefficient to try either to obtain feedback with 15 kHz sub-carrier resolution or to signal the modulation applied on a individual sub-carrier basis. Thus parameters such as modulation are fixed on the resource block basis.

The OFDMA transmission in the frequency domain thus consists of several parallel sub-carriers, which in the time domain correspond to multiple sinusoidal waves with different frequencies filling the system bandwidth with steps of 15 kHz. This causes the signal envelope to vary strongly, as shown in Figure 4.11, compared to a normal QAM modulator, which is only sending one symbol at a time (in the time domain). The momentary sum of sinusoids leads to the Gaussian distribution of different peak amplitude values.

This causes some challenges to the amplifier design as, in a cellular system, one should aim for maximum power amplifier efficiency to achieve minimum power consumption. Figure 4.12 illustrates how a signal with a higher envelope variation (such as the OFDMA signal in the time domain in Figure 4.11) requires the amplifier to use additional back-off compared to a regular single carrier signal. The amplifier must stay in the linear area with the use of extra power back-off in order to prevent problems to the output signal and spectrum mask. The use of additional back-off leads to a reduced amplifier power efficiency or a smaller output power. This either causes the uplink range to be shorter or, when the same average output power level

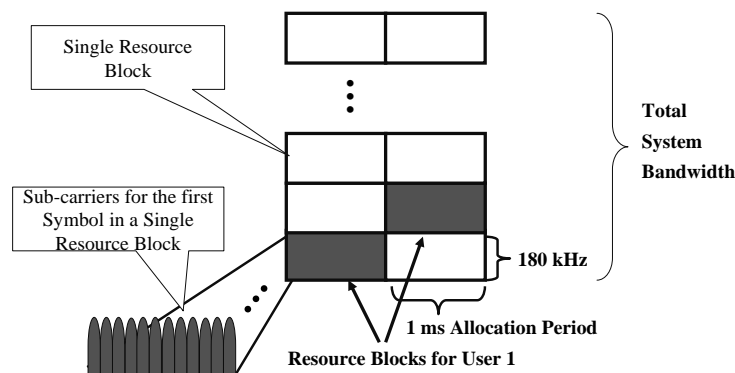

Figure 4.10 OFDMA resource allocation in LTE

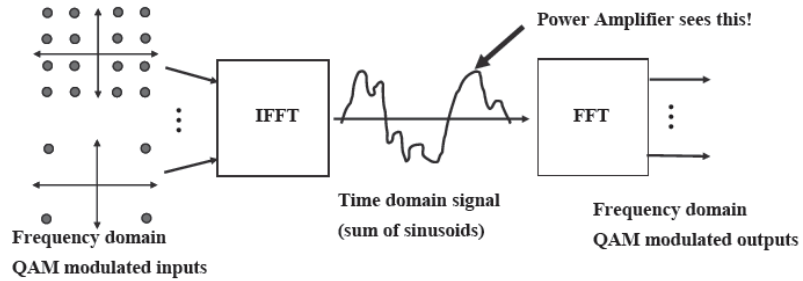

Figure 4.11 OFDMA signal envelope characteristics

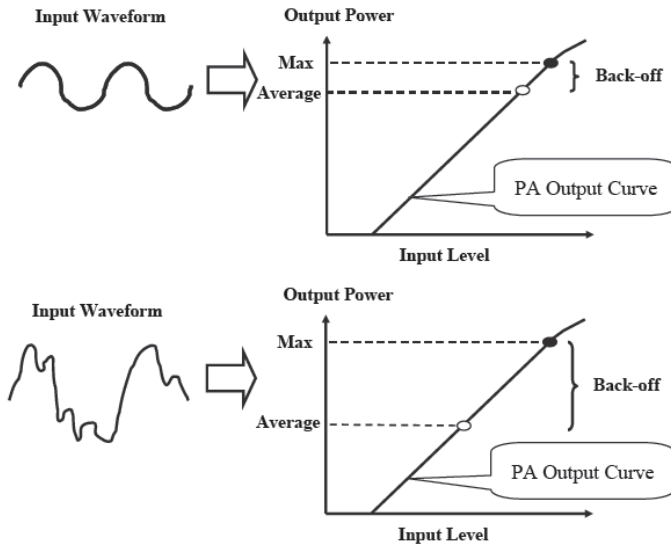

Figure 4.12 Power amplifier back-off requirements for different input waveforms

is maintained, the battery energy is consumed faster due to higher amplifier power consumption. The latter is not considered a problem in fixed applications where the device has a large volume and is connected to the mains, but for small mobile devices running on their own batteries it creates more challenges.

This was the key reason why 3GPP decided to use OFDMA in the downlink direction but to use the power efficient SC-FDMA in the uplink direction. Further principles of SC-FDMA are presented in the next section. From the research several methods are known to reduce the PAR, but of more significance – particularly for the amplifier – is the Cubic Metric (CM), which was introduced in 3GPP to better describe the impact to the amplifier. The exact definition of CM can be found from [5].

An OFDMA system is also sensitive to frequency errors as previously mentioned in section 4.2. The basic LTE sub-carrier spacing of 15 kHz facilitates enough tolerance for the effects of implementation errors and Doppler effect without too much degradation in the sub-carrier orthogonality. 3GPP has agreed that for broadcast only (on a dedicated carrier) an optional 7.5 kHz sub-carrier spacing can also be used, but full support of the broadcast only carrier is not part of the LTE Release 8. The physical layer details for the 7.5 kHz case principles can already be found in the 36.2 series specifications of Release 8, but details – especially for the higher layer operation – are only to be completed for releases after Release 8.

4.4 SC-FDMA Basics

In the uplink direction 3GPP uses SC-FDMA for multiple access, valid for both FDD and TDD modes of operation. The basic form of SC-FDMA could be seen as equal to the QAM modulation, where each symbol is sent one at a time similarly to Time Division Multiple Access (TDMA) systems such as GSM. Frequency domain generation of the signal, as shown in Figure 4.13, adds the OFDMA property of good spectral waveform in contrast to time domain signal generation with a regular QAM modulator. Thus the need for guard bands between different users can be avoided, similar to the downlink OFDMA principle. As in an OFDMA system, a cyclic prefix is also added periodically – but not after each symbol as the symbol rate is faster in the time domain than in OFDMA – to the transmission to prevent inter-symbol interference and to simplify the receiver design. The receiver still needs to deal with inter-symbol interference as the cyclic prefix now prevents inter-symbol interference between a block of symbols, and thus there will still be inter-symbol interference between the cyclic prefixes. The receiver will thus run the equalizer for a block of symbols until reaching the cyclic prefix that prevents further propagation of the inter-symbol interference.

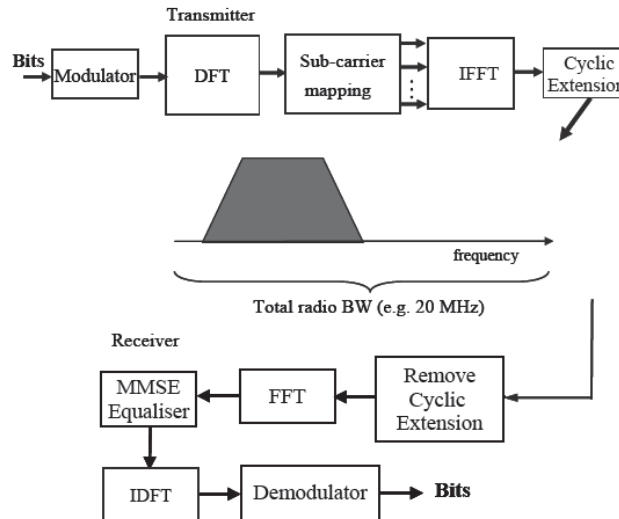

Figure 4.13 SC-FDMA transmitter and receiver with frequency domain signal generation

The transmission occupies the continuous part of the spectrum allocated to the user, and for LTE the system facilitates a 1 ms resolution allocation rate. When the resource allocation in the frequency domain is doubled, so is the data rate, assuming the same level of overhead. The individual transmission (with modulation) is now shorter in time but wider in the frequency domain, as shown in Figure 4.14. The example in Figure 4.14 assumes that in the new resource allocation the existing frequency resource is retained and the same amount of additional transmission spectrum is allocated, thus doubling the transmission capacity. In reality the allocations do not need to have frequency domain continuity, but can take any set of continuous allocation of frequency domain resources. The practical signaling constraints define the allowed amount of 180kHz resource blocks that can be allocated. The maximum allocated bandwidth depends on the system bandwidth used, which can be up to 20MHz. The resulting maximum allocation bandwidth is somewhat smaller as the system bandwidth definition includes a guard towards the neighboring operator. For example, with a 10MHz system channel bandwidth the maximum resource allocation is equal to 50 resource blocks thus having a transmission bandwidth of 9MHz. The relationship between the *Channel bandwidth* ($BW_{channel}$) and *Transmission bandwidth configuration* (N_{RB}) is covered in more detail in Chapter 11.

The SC-FDMA resource block for frequency domain signal generation is defined using the same values used in the OFDMA downlink, based on the 15kHz sub-carrier spacing. Thus even if the actual transmission by name is a single carrier, the signal generation phase uses a sub-carrier term. In the simplest form the minimum resource allocated uses 12 sub-carriers, and is thus equal to 180 kHz. The complex valued modulation symbols with data are allocated to the resource elements not needed for reference symbols (or control information) in the resource block, as shown in Figure 4.15. After the resource mapping has been done the signal is fed to the time domain signal generation that creates the SC-FDMA signal, including the selected length of the cyclic prefix. The example in Figure 4.15 assumes a particular length of cyclic prefix with the two different options introduced in Chapter 5.

As shown in Figure 4.15, reference symbols are located in the middle of the slot. These are used by the receiver to perform the channel estimation. There are different options for the reference symbols to be used; sometimes a reference symbol hopping pattern is also used, as covered in more detail in Chapter 5. Also specifically covered further in Chapter 5 are the sounding reference signals, which are momentarily sent over a larger bandwidth than needed,

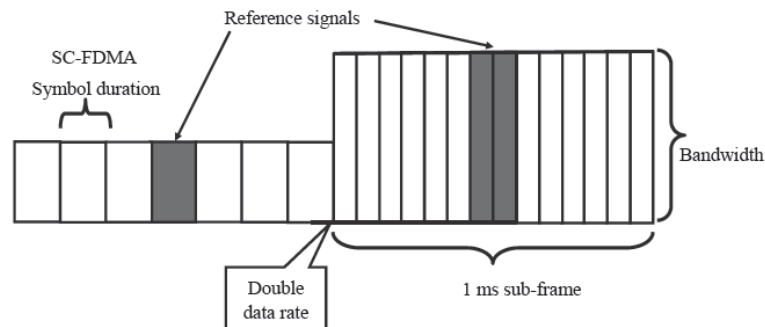

Figure 4.14 Adjusting data rate in a SC-FDMA system

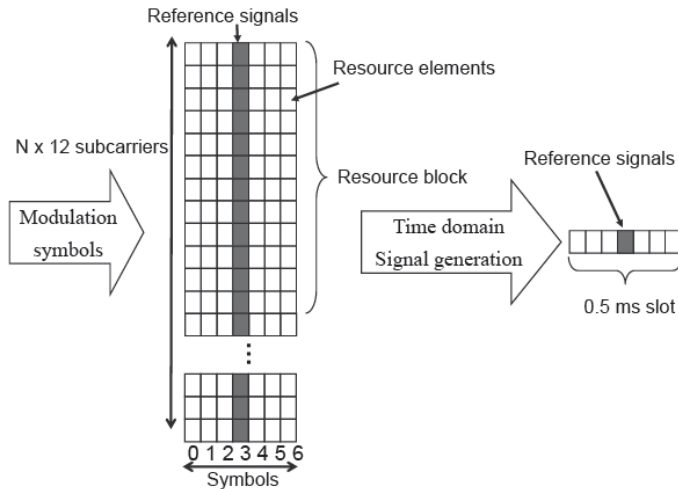

Figure 4.15 Resource mapping in SC-FDMA

for the data to give the base station receiver information of a larger portion of the frequency spectrum to facilitate frequency domain scheduling in the uplink direction.

Different users are thus sharing the resources in the time as well as in the frequency domain. In the time domain the allocation granularity is 1 ms and in the frequency domain it is 180 kHz. The base station needs to control each transmission so that they do not overlap in the resources. Also to avoid lengthy guard times, timing advance needs to be used, as presented in Chapter 5. By modifying the IFFT inputs, the transmitter can place the transmission in the desired part of the frequency, as shown in Figure 4.16. The base station receiver can detect the

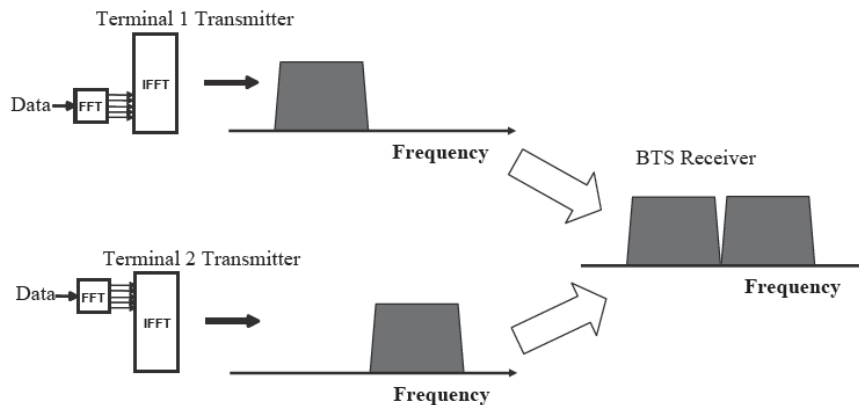

Figure 4.16 Multiple access with resource sharing in the frequency domain with SC-FDMA and frequency domain signal generation

transmission from the correct frequency/time resource. As all the uplink utilization is based on the base station scheduling, with the exception of the random access channel, the base station always knows which user to expect in which resource.

Since we are now transmitting in the time domain only a single modulation symbol at a time, the system retains its good envelope properties and the waveform characteristics are now dominated by the modulation method applied. This allows the SC-FDMA to reach a very low signal PAR or, even more importantly, CM facilitating efficient power amplifiers in the devices. The value of CM as a function modulation applied is shown in Figure 4.17. The use of a low CM modulation method such as Quadrature Phase Shift Keying (QPSK) allows a low CM value and thus the amplifier can operate close to the maximum power level with minimum back-off (Figure 4.17). This allows a good power conversion efficiency of the power amplifier and thus lowers the device power consumption. Note that the $\pi/2$ -Binary Phase Shift Keying (BPSK) was originally considered in 3GPP, but as 3GPP performance requirements are such that the full (23 dBm) power level needs to be reached with QPSK, there are no extra benefits for the use of $\pi/2$ -BPSK; thus, this was eventually not included in the specifications for user data. The modulation methods in LTE vary depending on whether the symbols are for physical layer control information or for higher layer data (user data or higher layer control signaling) transmission purposes (details in Chapter 5).

The base station receiver for SC-FDMA is slightly more complicated than the corresponding OFDMA receiver on the device side, especially when considering receivers (equalizers) that can reach a performance corresponding to that of an OFDMA receiver. This is the obvious consequence of the receiver having to deal with the inter-symbol interference that is terminated only after a block of symbols and not after every (long) symbol as in OFDMA. This increased need for processing power is, however, not foreseen to be an issue in the base station when compared to the device design constraints and was clearly considered to be outweighed by the benefits of the uplink range and device battery life with SC-FDMA. The benefits of a dynamic resource usage with a 1 ms resolution is also that there is no base-band receiver per UE on standby

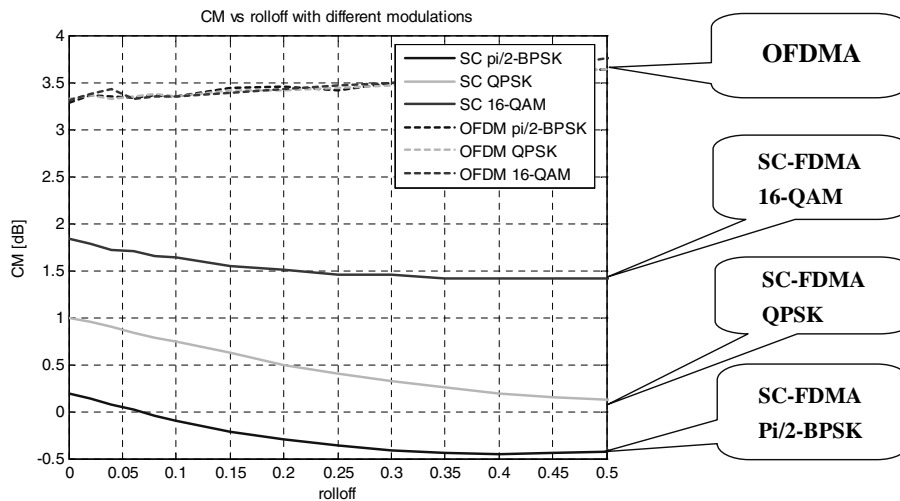

Figure 4.17 CM with OFDMA and SC-FDMA [6]. © 2006 IEEE

but the base station receiver is dynamically used for those users that have data to transmit. In any case the most resource consuming part both in uplink and downlink receiver chains is the channel decoding (turbo decoding) with the increased data rates.

4.5 MIMO Basics

One of the fundamental technologies introduced together with the first LTE Release is the Multiple Input Multiple Output (MIMO) operation including spatial multiplexing as well as pre-coding and transmit diversity. The basic principle in spatial multiplexing is sending signals from two or more different antennas with different data streams and by signal processing means in the receiver separating the data streams, hence increasing the peak data rates by a factor of 2 (or 4 with 4-by-4 antenna configuration). In pre-coding the signals transmitted from the different antennas are weighted in order to maximize the received Signal to Noise Ratio (SNR). Transmit diversity relies on sending the same signal from multiple antennas with some coding in order to exploit the gains from independent fading between the antennas. The use of MIMO has been included earlier in WCDMA specifications as covered in [4], but operating slightly differently than in LTE as a spreading operation is involved. The OFDMA nature is well suited for MIMO operation. As the successful MIMO operation requires reasonably high SNR, with an OFDMA system it can benefit from the locally (in the frequency/time domain) high SNR that is achievable. The basic principle of MIMO is presented in Figure 4.18, where the different data streams are fed to the pre-coding operation and then onwards to signal mapping and OFDMA signal generation.

The reference symbols enable the receiver to separate different antennas from each other. To avoid transmission from another antenna corrupting the channel estimation needed for separating the MIMO streams, one needs to have each reference symbol resource used by a single transmit antenna only. This principle is illustrated in Figure 4.19, where the reference symbols and empty resource elements are mapped to alternate between antennas. This principle can also be extended to cover more than two antennas, with the first LTE Release covering up to four antennas. As the number of antennas increases, the required SNR also increases the resulting transmitter/receiver complexity and the reference symbol overhead.

Even LTE uplink supports the use of MIMO technology. While the device is using only one transmit antenna, the single user data rate cannot be increased with MIMO. The cell level maximum data rate can be doubled, however, by the allocation of two devices with orthogonal reference signals. Thus the transmission in the base station is treated like a MIMO transmission, as shown in Figure 4.20, and the data stream separated with MIMO receiver processing. This

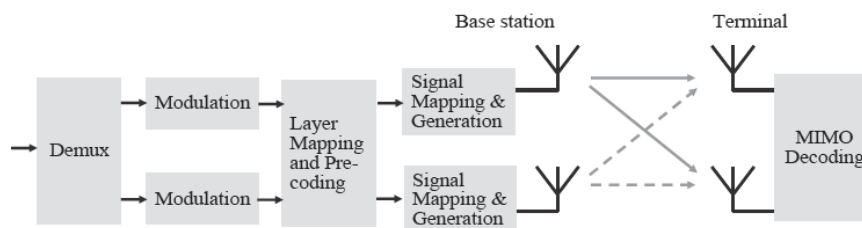

Figure 4.18 MIMO principle with two-by-two antenna configuration

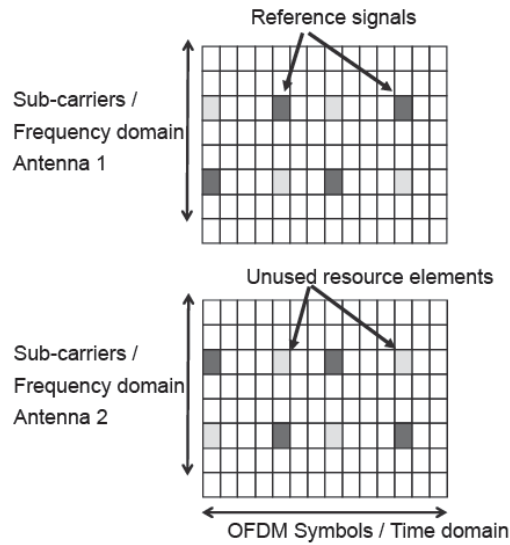

Figure 4.19 OFDMA reference symbols to support two eNodeB transmit antennas

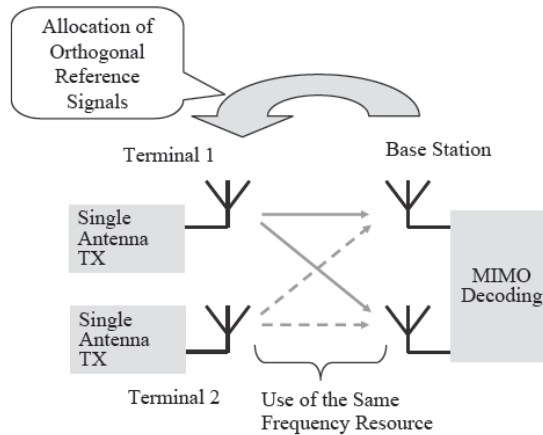

Figure 4.20 Multi-user MIMO principle with single transmit antenna devices

kind of ‘virtual’ or ‘Multi-user’ MIMO is supported in LTE Release 8 and does not represent any major implementation complexity from the device perspective as only the reference signal sequence is modified. From the network side, additional processing is needed to separate the users from each other. The use of ‘classical’ two antenna MIMO transmission is not particularly attractive due to the resulting device impacts, thus discussions on the device support of multi-antenna device transmission are expected to take place for later 3GPP Releases. The SC-FDMA

is well-suited for MIMO use as users are orthogonal (inside the cell) and thus the local SNR may be very high for users close to the base station.

4.6 Summary

Both OFDMA and SC-FDMA are very much related in terms of technical implementation and rely on the use of FFT/IFFT in the transmitter and receiver chain implementation. The SC-FDMA is used to optimize the range and power consumption in the uplink while the OFDMA is used in the downlink direction to minimize receiver complexity, especially with large bandwidths, and to enable frequency domain scheduling with flexibility in resource allocation. Multiple antenna operation with spatial multiplexing has been a fundamental technology of LTE from the outset, and is well suited for LTE multiple access solutions. The mathematical principles of OFDMA and SC-FDMA were not included in this chapter, but can be found from different text books, some of which are included in the references, e.g. [7] for OFDMA and [8] for SC-FDMA.

References

- [1] Proakis, J.G., 'Digital Communications', 3rd edition, McGraw-Hill Book Co., 1995.
- [2] Czylik, A., 'Comparison between adaptive OFDM and single carrier modulation with frequency domain equalisation', IEEE Vehicular Technology Conference 1997, VTC-97, Phoenix, USA, pp. 863–869.
- [3] Toskala, A., Castro, J., Chalard, L., Hämäläinen, S., Kalliojärvi, K., 'Cellular OFDM/CDMA Downlink Performance in the link and system level', IEE Vehicular Technology Conference 1997, VTC-97, Phoenix, USA, pp. 855–859.
- [4] Holma, H., Toskala, A., 'WCDMA for UMTS', 4th edition, Wiley, 2007.
- [5] Holma, H., Toskala, A., 'HSDPA/HSUPA for UMTS', Wiley, 2006.
- [6] Toskala, A., Holma, H., Pajukoski, K., Tirola, E., 'UTRAN Long Term Evolution in 3GPP'. The 17th Annual IEEE International Symposium on Personal, Indoor and Mobile Radio Communications (PIMRC '06), in Proceedings, 2006, Helsinki, Finland.
- [7] Schulze, H., Luders, C., 'Theory and Applications of OFDMA and CDMA', Wiley, 2005.
- [8] Myung, H.G., Goodman, D.J., 'Single Carrier FDMA: A New Air Interface for Long Term Evolution', Wiley, 2008.

5

Physical Layer

Antti Toskala, Timo Lunttila, Esa Tirola, Kari Hooli and Juha Korhonen

5.1 Introduction

In this chapter the physical layer of LTE is described, based on the use of OFDMA and SC-FDMA principles as covered in Chapter 4. The LTE physical layer is characterized by the design principle of resource usage based solely on dynamically allocated shared resources rather than having dedicated resources reserved for a single user. This has an analogy with the resource usage in the internet, which is packet based without user specific resource allocation. The physical layer of a radio access system has a key role in defining the resulting capacity and becomes a focal point when comparing different systems for expected performance. Of course a competitive system requires an efficient protocol layer to ensure good performance through to both the application layer and the end user. The flat architecture adopted, as covered in Chapter 3, also enables the dynamic nature of the radio interface because all radio resource control is located close to the radio in the base station site. The 3GPP term for the base station used in this chapter is eNodeB (different to the WCDMA BTS term, which is Node B; e stands for 'evolved'). This chapter first covers the physical channel structures and then introduces the channel coding and physical layer procedures. It concludes with a description of physical layer measurements and device capabilities as well as a brief look at aspects of the parameter configuration of the physical layer. In 3GPP specifications the physical layer was covered in 36.2 series, with the four key physical layer specifications being [1–4]. Many of the issues in this chapter are valid to both FDD and TDD, but in some areas TDD has special solutions because the frame is divided between uplink and downlink. The resulting differences needed for a TDD implementation are covered in Chapter 12.

5.2 Transport Channels and Their Mapping to the Physical Channels

By the nature of the design already discussed, the LTE contains only common transport channels; a dedicated transport channel (Dedicated Channel, DCH, as in WCDMA) does not exist. The transport channels are the 'interface' between the Medium Access Control (MAC) layer

and the physical layer. Each transport channel is characterized by the related physical layer processing applied to the corresponding physical channels used to carry the transport channel in question. The physical layer needs to be able to provide dynamic resource assignment both for data rate variance and for resource division between different users. This section presents the transport channels and their mapping to the physical channels.

- Broadcast Channel (BCH) is a downlink broadcast channel that is used to broadcast the necessary system parameters to enable devices accessing the system (and to identify the operator). Such parameters include, for example, random access related parameters that inform the device about which resource elements are reserved for random access operation.
- Downlink Shared Channel (DL-SCH) carries the user data for point-to-point connections in the downlink direction. All the information (either user data or higher layer control information) intended for only one user or UE is transmitted on the DL-SCH, assuming the UE is already in the RRC_CONNECTED state. As in LTE, however, the role of BCH is mainly for informing the device of the scheduling of the system information; control information intended for multiple devices is carried on DL-SCH as well. In case data on DL-SCH are intended for a single UE only, then dynamic link adaptation and physical layer retransmissions can be used.
- Paging Channel (PCH) is used for carrying the paging information for the device in the downlink direction to move the device from a RRC_IDLE state to a RRC_CONNECTED state.
- Multicast Channel (MCH) is used to transfer multicast service content to the UE in the downlink direction. 3GPP has decided to postpone the full support beyond Release 8.
- Uplink Shared Channel (uplink-SCH) carries the user data as well as device originated control information in the uplink direction in the RRC_CONNECTED state. Similar to the DL-SCH, dynamic link adaptation and retransmissions are available.
- Random Access Channel (RACH) is used in the uplink to respond to the paging message or to initiate the move from/to the RRC_CONNECTED state according to UE data transmission needs. There is no higher layer data or user data transmitted on RACH (such as can be done with WCDMA) but it is used just to enable uplink-SCH transmission where, for example, actual connection set-up with authentication, etc. will take place.

In the uplink direction the uplink-SCH is carried by the Physical Uplink Shared Channel (PUSCH). Correspondingly, the RACH is carried by the Physical Random Access Channel (PRACH). An additional physical channel exists but it is used only for physical layer control information transfer (as covered in connection with section 5.6 on control information). Uplink transport channel mapping to physical channels is illustrated in Figure 5.1.

In the downlink direction the PCH is mapped to the Physical Downlink Shared Channel (PDSCH). The BCH is mapped to Physical Broadcast Channel (PBCH), but as shown in Chapter 6 for the mapping of logical channels to transport channels, only part of the broadcasted param-

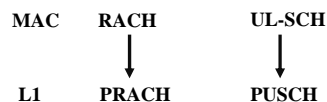

Figure 5.1 Mapping of the uplink transport channels to the physical channels



Figure 5.2 Mapping of the downlink transport channels to the physical channels

eters are on BCH while the actual System Information Blocks (SIBs) are then on DL-SCH. The DL-SCH is mapped to the PDSCH and MCH is mapped to the Physical Multicast Channel, as shown in Figure 5.2.

5.3 Modulation

In the uplink direction the modulation is the more traditional Quadrature Amplitude Modulation (QAM) modulator, as was explained in Chapter 4. The modulation methods available (for user data) are Quadrature Phase Shift Keying (QPSK), 16QAM and 64QAM. The first two are available in all devices while the support for 64QAM in the uplink direction is a UE capability, as covered in section 5.10. The different constellations are shown in Figure 5.3.

The PRACH modulation is phase modulation as the sequences used are generated from Zadoff–Chu sequences with phase differences between different symbols of the sequences (see section 5.7 for further details). Depending on the sequence chosen, the resulting Peak-to-Average Ratio (PAR) or the more practical Cubic Metric (CM) value is somewhat lower or higher compared to the QPSK value. In the uplink direction, the CM signal was discussed in Chapter 4 with SC-FDMA.

The use of QPSK modulation allows good transmitter power efficiency when operating at full transmission power as modulation determines the resulting CM (for SC-FDMA) and thus also the required device amplifier back-off. The devices will use lower maximum transmitter power when operating with 16QAM or 64QAM modulation.

In the downlink direction, the modulation methods for user data are the same as in the uplink direction. In theory an OFDM system could use different modulations for each sub-carrier. To have channel quality information (and signaling) with such a granularity would not be feasible due to the resulting excessive overhead. If modulation was sub-carrier specific, there would be too many bits in the downlink for informing the receiver of parameters for each sub-carrier and in the uplink the Channel Quality Indicator (CQI) feedback would need to be too detailed to achieve sub-carrier level granularity in the adaptation.

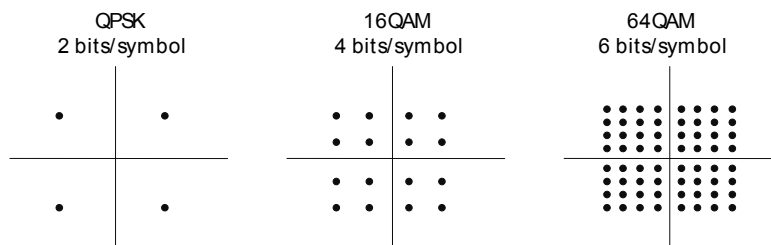

Figure 5.3 LTE modulation constellations

Also Binary Phase Shift Keying (BPSK) has been specified for control channels, which use either BPSK or QPSK for control information transmission. For a control channel, the modulation cannot be freely adapted as one needs to be able to receive them, and a single signaling error must not prevent detecting later control channel messages. This is similar to HSDPA/HSUPA where the control channels have fixed parameterization to prevent error propagation due to frame loss events. The exception is the uplink control data when multiplexed together with the user data – there modulation for data and control is the same – even if 16QAM or 64QAM would be used. This allows the multiplexing rules to be kept simpler.

5.4 Uplink User Data Transmission

The user data in the uplink direction is carried on the PUSCH, which has a 10ms frame structure and is based on the allocation of time and frequency domain resources with 1ms and 180kHz resolution. The resource allocation comes from a scheduler located in the eNodeB, as illustrated in Figure 5.4. Thus there are no fixed resources for the devices, and without prior signaling from the eNodeB only random access resources may be used. For this purpose the device needs to provide information for the uplink scheduler of the transmission requirements (buffer status) it has as well as on the available transmission power resources. This signaling is MAC layer signaling and is covered in detail in Chapter 6.

The frame structure adopts the 0.5ms slot structure and uses the 2 slot (1 subframe) allocation period. The shorter 0.5ms allocation period (as initially planned in 3GPP to minimize the round trip time) would have been too signal intensive especially with a large number of users. The 10ms frame structure is illustrated in Figure 5.5. The frame structure is basically valid for both for FDD and TDD, but TDD mode has additional fields for the uplink/downlink transition point(s) in the frame, as covered in Chapter 12.

Within the 0.5ms slot there are both reference symbols and user data symbols, in addition to the signaling, covered in a later section. The momentary user data rate thus varies as a function of the uplink resource allocation depending on the allocated momentary bandwidth. The

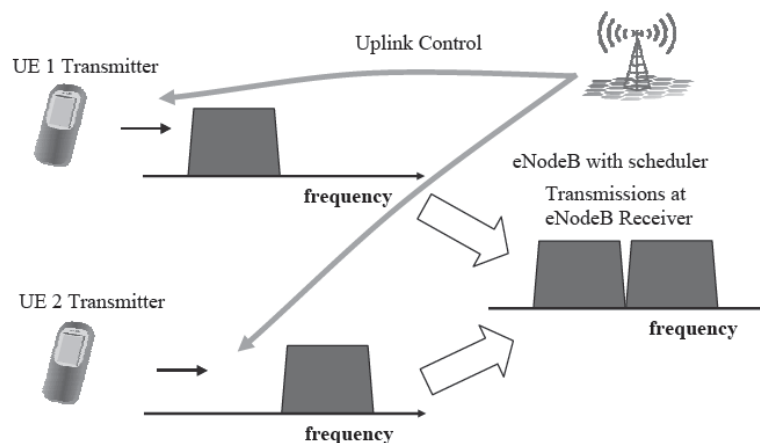

Figure 5.4 Uplink resource allocation controlled by eNodeB scheduler

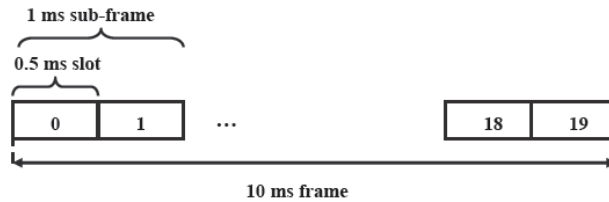

Figure 5.5 LTE FDD frame structure

allocation bandwidth may be between 0 and 20MHz in the steps of 180kHz. The allocation is continuous as uplink transmission is FDMA modulated with only one symbol being transmitted at a time. The slot bandwidth adjustment between consecutive TTIs is illustrated in Figure 5.6, where doubling the data rate results in double the bandwidth being used. The reference symbols always occupy the same space in the time domain and thus a higher data rate results in a corresponding increase for the reference symbol data rate.

The cyclic prefix used in uplink has two possible values depending on whether a short or extended cyclic prefix is applied. Other parameters stay unchanged and thus the 0.5 ms slot can accommodate either six or seven symbols as indicated in Figure 5.7. The data payload is reduced if an extended cyclic prefix is used, but it is not used frequently as usually the performance benefit in having seven symbols is far greater than the possible degradation from inter-symbol interference due to channel delay spread longer than the cyclic prefix.

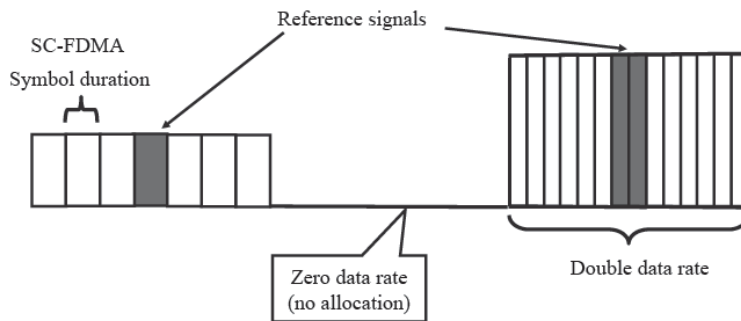

Figure 5.6 Data rate between TTIs in the uplink direction

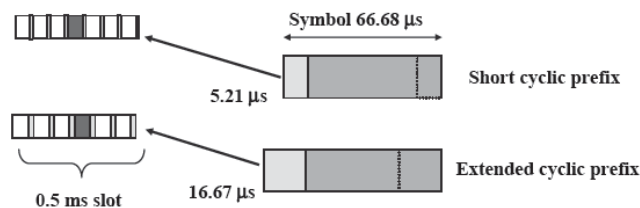

Figure 5.7 Uplink Slot structure with short and extended cyclic prefix

The resulting instantaneous uplink data rate over a 1 ms subframe is a function of the modulation, the number of resource blocks allocated, and the amount of control information overhead as well as of the rate of channel coding applied. The range of the instantaneous uplink peak data rate when calculated from the physical layer resources is between 700 kbps and 86 Mbps. There is no multi-antenna uplink transmission specified in Release 8, as using more than one transmitter branch in a UE is not seen as that attractive from the cost and complexity perspective. The instantaneous data rate for one UE depends on the LTE uplink from:

- Modulation method applied, with 2, 4 or 6 bits per modulation symbol depending on the modulation order for QPSK, 16QAM and 64QAM respectively.
- Bandwidth applied. For 1.4 MHz, the overhead is the largest due to the common channels and synchronization signals. The momentary bandwidth may of course vary between the minimum allocation of 12 sub-carriers (one resource block of 180 kHz) and the system bandwidth, up to 1200 sub-carriers with a 20 MHz bandwidth.
- Channel coding rate applied.
- The average data rate then depends on the time domain resource allocation as well.

The cell or sector specific maximum total data throughput can be increased with the Virtual Multiple Input Multiple Output (V-MIMO). In V-MIMO the eNodeB will treat transmission from two different UEs (with a single transmit antenna each) as one MIMO transmission and separate the data streams from each other based on the UE specific uplink reference symbol sequences. Thus V-MIMO does not contribute to the single user maximum data rate. The maximum data rates taking into account the UE categories are presented in section 5.10, while the maximum data rates for each bandwidth are covered in Chapter 9.

The channel coding chosen for LTE user data was turbo coding. The encoder is Parallel Concatenated Convolution Coding (PCCC) type turbo encoder, exactly the same as in WCDMA/HSPA, as explained in [5]. The turbo interleaver of WCDMA was modified to better fit LTE properties and slot structures and also to allow more flexibility for implementation of parallel signal processing with increased data rates.

LTE also uses physical layer retransmission combining, often referred to as Hybrid Adaptive Repeat and Request (HARQ). In a physical layer HARQ operation the receiver also stores the packets with failed CRC checks and combines the received packet when a retransmission is received. Both soft combining with identical retransmissions and combining with incremental redundancy are facilitated.

The channel coding chain for uplink is shown in Figure 5.8, where the data and control information are separately coded and then mapped to separate symbols for transmission. As the control information has specific locations around the reference symbols, the physical layer control information is separately coded and placed in a predefined set of modulation symbols (but with the same modulation as if the data were transmitted together). Thus the channel interleaver in Figure 5.8 does not refer to truly joint interleaving between control and data.

The data and control information are time multiplexed in the resource element level. Control is not evenly distributed but intended to be either closest for the reference symbols in time domain or then filled in the top rows of Figure 5.9, depending on the type of control information (covered in section 5.6). Data are modulated independently of the control information, but modulation during the 1 ms TTI is the same.

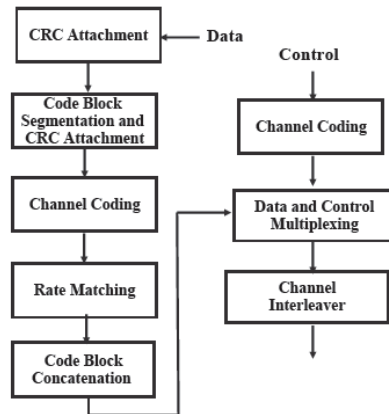

Figure 5.8 PUSCH Channel Coding Chain

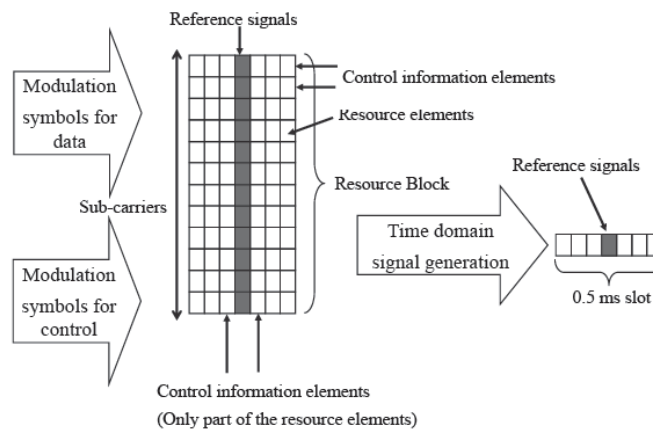

Figure 5.9 Multiplexing of uplink control and data

5.5 Downlink User Data Transmission

The user data rate in the downlink direction is carried on the Physical Downlink Shared Channel (PDSCH). The same 1 ms resource allocation is also valid in the downlink direction. The sub-carriers are allocated to resource units of 12 sub-carriers resulting in 180kHz allocation units (Physical Resource Blocks, PRBs). With PDSCH, however, as the multiple access is OFDMA, each sub-carrier is transmitted as a parallel 15kHz sub-carrier and thus the user data rate is dependent on the number of allocated sub-carriers (or resource blocks in practice) for a given user. The eNodeB carries out the resource allocation based on the Channel Quality Indicator (CQI) from the terminal. Similarly to the uplink, the resources are allocated in both the time and the frequency domain, as illustrated in Figure 5.10.

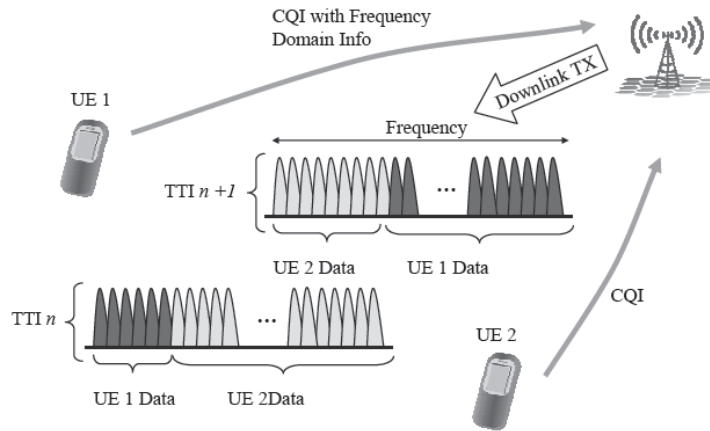

Figure 5.10 Downlink resource allocation at eNodeB

The Physical Downlink Control Channel (PDCCH) informs the device which resource blocks are allocated to it, dynamically with 1 ms allocation granularity. PDSCH data occupy between 3 and 6 symbols per 0.5 ms slot depending on the allocation for PDCCH and depending whether a short or extended cyclic prefix is used. Within the 1 ms subframe, only the first 0.5 ms slot contains PDCCH while the second 0.5 ms slot is purely for data (for PDSCH). For an extended cyclic prefix, 6 symbols are accommodated in the 0.5 ms slot, while with a short cyclic prefix 7 symbols can be fitted, as shown in Figure 5.11. The example in Figure 5.11 assumes there are 3 symbols for PDCCH but this can vary between 1 and 3. With the smallest bandwidth of 1.4 MHz the number of symbols varies between 2 and 4 to enable sufficient signaling capacity and enough bits to allow for good enough channel coding in range critical cases.

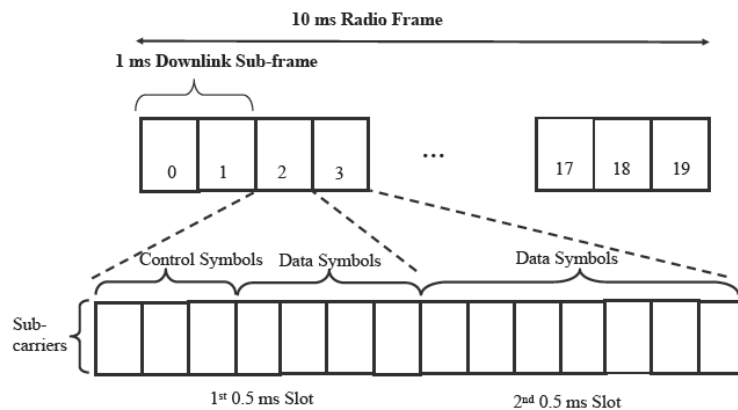

Figure 5.11 Downlink slot structure for bandwidths above 1.4 MHz

In addition to the control symbols for PDCCH, space from the user data is reduced due to the reference signals, synchronization signals and broadcast data. As discussed in Chapter 4, due to channel estimation it is beneficial when the reference symbols are distributed evenly in the time and frequency domains. This reduces the overhead needed, but requires some rules to be defined so that both receiver and transmitter understand the resource mapping in a similar manner. From the total resource allocation space over the whole carrier one needs to account for common channels, such as PBCH, that consume their own resource space. In Figure 5.12 an example of PDCCH and PDSCH resource allocation is presented. Note that the reference symbol placement in Figure 5.12 is purely illustrative and does not represent an actual reference symbol pattern.

The channel coding for user data in the downlink direction was also 1/3-rate turbo coding, as in the uplink direction. The maximum block size for turbo coding is limited to 6144 bits to reduce the processing burden, higher allocations are then segmented to multiple encoding blocks. Higher block sizes would not add anything to performance as the turbo encoder performance improvement effect for big block sizes has been saturated much earlier. Besides the turbo coding, downlink also has the physical layer HARQ with the same combining methods as in the uplink direction. The device categories also reflect the amount of soft memory available for retransmission combining. The downlink encoding chain is illustrated in Figure 5.13. There is no multiplexing to the same physical layer resources with PDCCH as they have their own separate resources during the 1 ms subframe.

Once the data have been encoded, the code words are provided onwards for scrambling and modulation functionality. The scrambling in the physical layer should not be confused with ciphering functionality but is just intended to avoid the wrong device successfully decoding the data should the resource allocations happen to be identical between cells. The modulation mapper applies the desired modulation (QPSK, 16QAM or 64QAM) and then symbols are fed for layer mapping and pre-coding. For multiple transmit antennas (2 or 4) the data are then divided into as many different streams and then mapped to correct resource elements available for PDSCH and then the actual OFDMA signal is generated, as shown in Figure 5.14 with an example of 2 antenna transmission. Should there be only a single transmit antenna available,

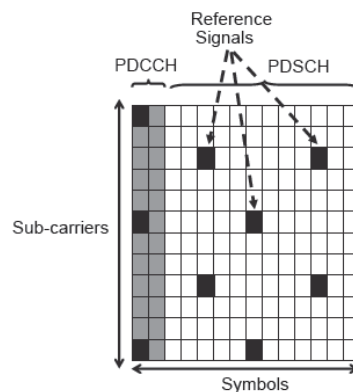

Figure 5.12 Example of downlink resource sharing between PDCCH and PDSCH

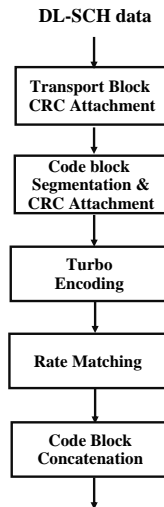

Figure 5.13 DL-SCH Channel Encoding Chain

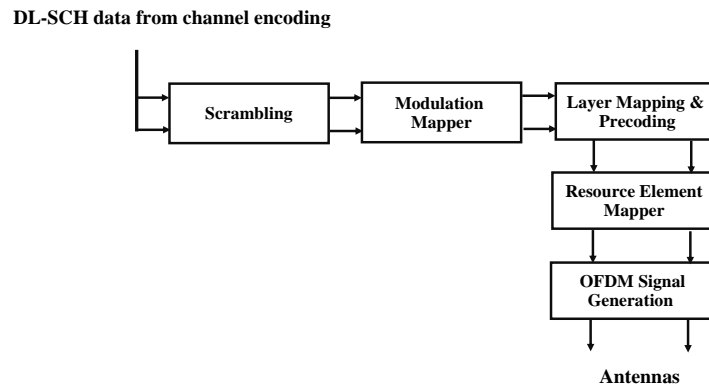

Figure 5.14 Downlink signal generation

then obviously the layer mapping and pre-coding functionalities do not have a role in signal transmission.

The resulting instantaneous data rate for downlink depends on:

- Modulation, with the same methods possible as in the uplink direction.
- Allocated amount of sub-carriers. Note that in the downlink the resource blocks are not necessary having continuous allocation in the frequency domain. The range of allocation is the same as in the uplink direction from 12 sub-carriers (180 kHz) up to the system bandwidth with 1200 sub-carriers.
- Channel encoding rate.
- Number of transmit antennas (independent streams) with MIMO operation.

The instantaneous peak data rate for downlink (assuming all resources to a single user and counting only the physical layer resources available) ranges between 0.7 Mbps and 170 Mbps. Even 300 Mbps or higher could be expected if using 4-by-4 antenna MIMO operation. There is no limit on the smallest data rate, and should the smallest allocation unit (1 resource block) be too high, then padding could be applied. Section 5.10 presents the maximum data rates taking the UE categories into account. The possible data rates for different bandwidth/coding/modulation combinations are presented in Chapter 9.

5.6 Uplink Physical Layer Signaling Transmission

Uplink Layer 1/Layer 2 (L1/L2) control signaling is divided into two classes in the LTE system:

- control signaling in the absence of uplink data, which takes place on PUCCH (Physical Uplink Control Channel);
- control signaling in the presence of uplink data, which takes place on PUSCH (Physical Uplink Shared Channel).

Due to single carrier limitations, simultaneous transmission of PUCCH and PUSCH is not allowed. This means that separate control resources are defined for the cases with and without uplink data. Alternatives considered were parallel transmission in the frequency domain (bad for the transmitter envelope) or pure time division (bad for control channel coverage). The selected approach maximizes the link budget for PUCCH and always maintains the single carrier properties on the transmitted signal.

PUCCH is a shared frequency/time resource reserved exclusively for User Equipment (UE) transmitting only L1/L2 control signals. PUCCH has been optimized for a large number of simultaneous UEs with a relatively small number of control signaling bits per UE.

PUSCH carries the uplink L1/L2 control signals when the UE has been scheduled for data transmission. PUSCH is capable of transmitting control signals with a large range of supported signaling sizes. Data and different control fields such as ACK/NACK and CQI are separated by means of Time Division Multiplexing (TDM) by mapping them into separate modulation symbols prior to the Discrete Fourier Transform (DFT). Different coding rates for control are achieved by occupying a different number of symbols for each control field.

There are two types of uplink L1 and L2 control-signaling information, as discussed in [6]:

- data-associated signaling (e.g. transport format and HARQ information), which is associated with uplink data transmission;
- data-non-associated signaling (ACK/NACK due to downlink transmissions, downlink CQI, and scheduling requests for uplink transmission).

It has been decided that there is no data-associated control signaling in the LTE uplink. Furthermore, it is assumed that eNodeB is not required to perform blind transport format detection. Basically this means that UE just obeys the uplink scheduling grant with no freedom in transport format selection. Furthermore, there is a new data indicator (1 bit) together with implicit information about the redundancy version included in the uplink grant [7]. This guarantees that the eNodeB always has exact knowledge about the uplink transport format.

5.6.1 Physical Uplink Control Channel (PUCCH)

From the single UE perspective, PUCCH consists of a frequency resource of one resource block (12 sub-carriers) and a time resource of one subframe. To handle coverage-limited situations, transmission of ACK/NACK spans the full 1 ms subframe. Furthermore, to support situations where coverage is extremely limited it has been agreed that ACK/NACK repetition is supported in the LTE uplink. Slot-based frequency hopping on the band edges symmetrically over the center frequency is always used on PUCCH, as shown in Figure 5.15. Frequency hopping provides the necessary frequency diversity needed for delay critical control signaling.

Different UEs are separated on PUCCH by means of Frequency Division Multiplexing (FDM) and Code Division Multiplexing (CDM). FDM is used only between the resource blocks whereas CDM is used inside the PUCCH resource block.

Two ways to realize CDM inside the PUCCH resource block are:

- CDM by means of cyclic shifts of a Constant Amplitude Zero Autocorrelation Codes (CAZAC)¹ sequence;
- CDM by means of block-wise spreading with the orthogonal cover sequences.

The main issue with CDM is the well-known near-far problem. Orthogonality properties of the considered CDM techniques were carefully studied during the Work Item phase of LTE standardization. We note that:

- channel delay spread limits the orthogonality between cyclically shifted CAZAC sequences;
- channel Doppler spread limits the orthogonality between block-wise spread sequences.

Orthogonality properties are optimized by means of a staggered and configurable channelization arrangement (see more details in section 5.6.2), proper configuration of block spreading, and a versatile randomization arrangement including optimized hopping patterns used for the control channel resources and the applied CAZAC sequences.

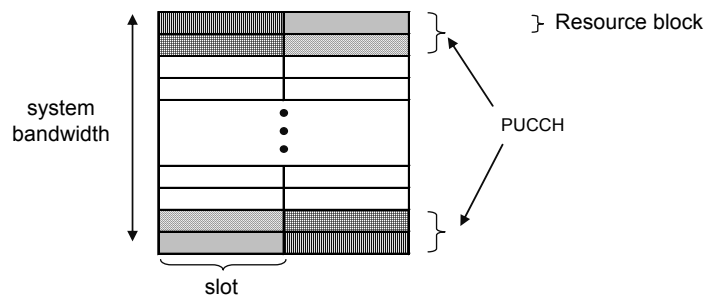

Figure 5.15 PUCCH resource

¹The applied sequences are not true CAZAC but computer searched Zero-Autocorrelation (ZAC) sequences. The same sequences are applied as reference signals with a bandwidth allocation of one resource block.

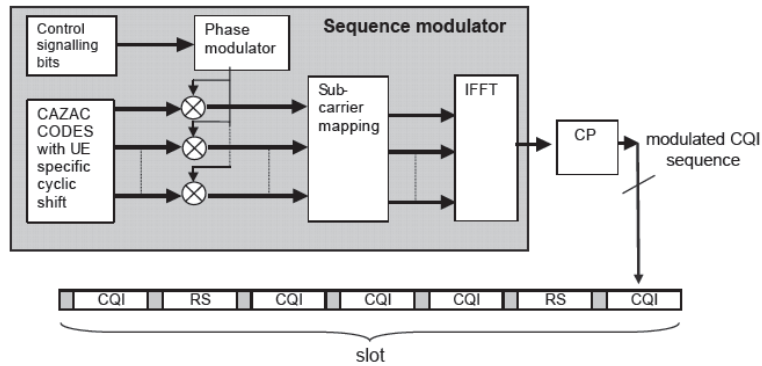

Figure 5.16 Block diagram of CAZAC sequence modulation applied for CQI

5.6.1.1 Sequence Modulation

Control signalling on PUCCH is based on sequence modulation. Cyclically shifted CAZAC sequences take care of both CDM and conveying the control information. A block diagram of the sequence modulator configured to transmit periodic CQI on PUCCH is shown in Figure 5.16. On the PUCCH application CAZAC sequences with a length of 12 symbols (1 resource block) are BPSK or QPSK modulated, thus carrying one or two information bits per sequence. Different UEs can be multiplexed into the given frequency/time resource by allocating different cyclic shifts of the CAZAC sequence for them. There are six parallel channels available per resource block, assuming that every second cyclic shift is in use.

5.6.1.2 Block-wise Spreading

Block-wise spreading increases the multiplexing capacity of PUCCH by a factor of the spreading factor (SF) used. The principle of block-wise spreading is shown in Figure 5.17, which illustrates

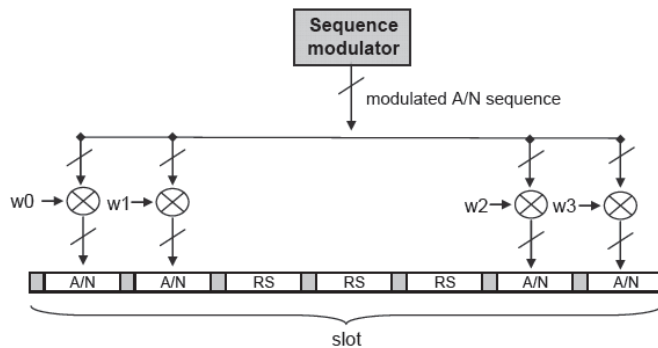

Figure 5.17 Principle of block spreading applied for ACK/NACK, spreading SF=4

the block spreading operation made for an ACK/NACK data sequence transmitted on PUCCH. A separate block spreading operation is made for the reference signal and the ACK/NACK data parts but for simplicity, block processing related to the Reference Symbol (RS) part is neglected in Figure 5.17. In the example in Figure 5.17, the spreading factor applied for the ACK/NACK data and RS parts is equal to 4 and 3 respectively. Walsh–Hadamard codes are used as block spreading codes with SF=4 and SF=2, whereas DFT codes are used when SF=3.

5.6.1.3 PUCCH Formats

The available PUCCH formats are summarized in Table 5.1. PUCCH Format 1/1a/1b is based on the combination of CAZAC sequence modulation and block-wise spreading whereas PUCCH Format 2/2a/2b uses only CAZAC sequence modulation. As a result, Format 1/1a/1b can only carry one information symbol (1 to 2 bits) per slot while Format 2/2a/2b is capable of conveying 5 symbols per slot (20 coded bits + ACK/NACK per subframe). With Format 2/2a/2b, the CQI data are encoded using a punctured (20, M) Reed–Muller block code.

The supported control signaling formats were selected based on a careful evaluation process. The main issues of the evaluation phase were the link performance and multiplexing capacity as well as compatibility with other formats. It is also noted that the number of reference signal blocks were optimized separately for different formats.

Two different approaches were selected for signaling the ACK/NACK and CQI on PUCCH (Format 2a/2b):

- Normal cyclic prefix: ACK/NACK information is modulated in the second CQI reference signals of the slot. The RS modulation follows the CAZAC sequence modulation principle.
- Extended cyclic prefix: ACK/NACK bits and the CQI bits are jointly coded. No information is embedded in any of the CQI reference signals.

The main reason for having different solutions for normal and extended cyclic prefix lengths was that with an extended cyclic prefix there is only one reference signal per slot and hence the method used with the normal cyclic prefix cannot be used.

Support of Format 2a/2b is made configurable in the LTE uplink system. In order to guarantee ACK/NACK coverage, the eNodeB can configure a UE to drop the CQI when ACK/NACK and CQI would appear in the same subframe on PUCCH. In this configuration, Format 1a/1b is used instead of Format 2a/2b.

Table 5.1 PUCCH formats

PUCCH Formats	Control type	Modulation (data part)	Bit rate (raw bits/subframe)	Multiplexing capacity (UE/RB)
1	Scheduling request	Unmodulated	– (on/off keying)	36, 18*, 12
1a	1-bit ACK/NACK	BPSK	1	36, 18*, 12
1b	2-bit ACK/NACK	QPSK	2	36, 18*, 12
2	CQI	QPSK	20	12, 6*, 4
2a	CQI + 1-bit ACK/NACK	QPSK	21	12, 6*, 4
2b	CQI + 2-bit ACK/NACK	QPSK	22	12, 6*, 4

*Typical value

5.6.1.4 Scheduling Request

One of the new features of the LTE uplink system is the support of fast uplink scheduling request mechanism for the active mode UE (RRC_CONNECTED) being synchronized by the eNodeB but having no valid uplink grant on PUSCH available. The supported scheduling request procedure is presented in Figure 5.18 [8].

The UE indicates the need for an uplink resource by a Scheduling Request Indicator (SRI). During the Release 8 LTE standardization process, the contention based synchronized RACH and non-contention based SRI mechanisms were compared. It was pointed out that a non-contention based approach is better suited to LTE uplink usage because it provides better coverage, a smaller system overhead and better delay performance than a non-contention based approach [9].

The SRI is transmitted using PUCCH Format 1. On-off keying based signaling is applied with SRI, i.e. only the positive SRI is transmitted. The positive SRI is transmitted using the ACK/NACK structure [1], the only difference between the SRI and the ACK/NACK formats is that with SRI the data part is not modulated. The benefit of this arrangement is that SRI and ACK/NACK can share the same physical resources.

5.6.2 PUCCH Configuration

Figure 5.19 shows the logical split between different PUCCH formats and the way in which the PUCCH is configured in the LTE specifications [1]. The number of resource blocks in a slot reserved for PUCCH transmission is configured by the N_{RB}^{HO} -parameter. This broadcasted system parameter can be seen as the maximum number of resource blocks reserved for PUCCH while actual PUCCH size changes dynamically based on Physical Control Format Indicator Channel (PCFICH) transmitted on the downlink control channel. The parameter is used to define the frequency hopping PUSCH region. The number of resource blocks reserved for periodic CQI (i.e. PUCCH Format 2/2a/2b) is configured by another system parameter, $N_{RB}^{(2)}$.

In general it makes sense to allocate separate PUCCH resource blocks for PUCCH Format 1/1a/1b and Format 2/2a/2b. With narrow system bandwidth options such as 1.4 MHz, however, this would lead to unacceptably high PUCCH overhead [10]. Therefore, sharing the PUCCH resources block between Format 1/1a/1b and Format 2/2a/2b users is supported in the LTE specifications. The mixed resource block is configured by the broadcasted system parameter $N_{CS}^{(1)}$, which is the number of cyclic shifts reserved for PUCCH Format 1/1a/1b on the mixed PUCCH resource block.

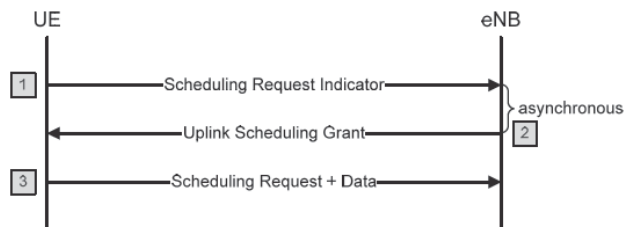

Figure 5.18 Scheduling request procedure

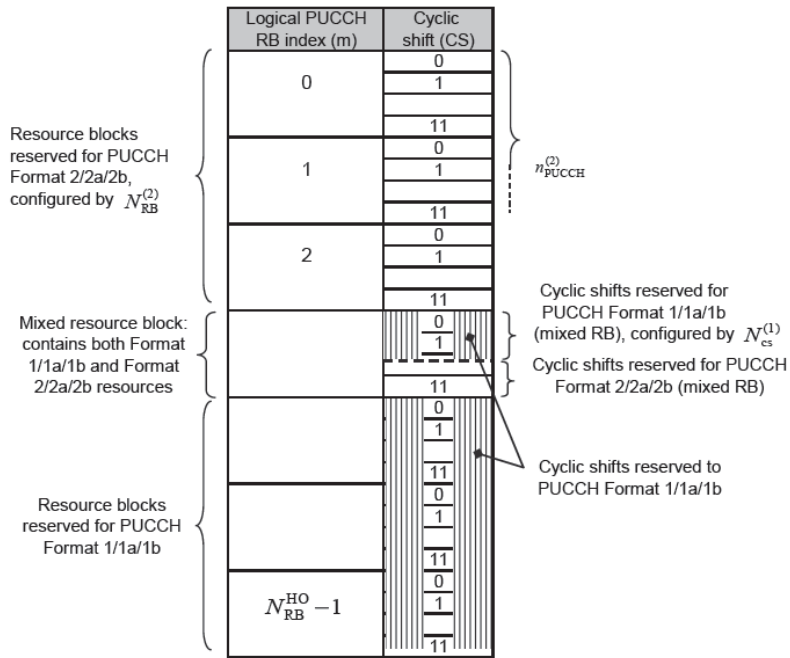

Figure 5.19 PUCCH configuration

Resources used for transmission of PUCCH Format 2/2a/2b are identified by a resource index $n_{PUCCH}^{(2)}$, which is mapped directly into a single CS resource. This parameter is explicitly signaled via UE-specific higher layer signaling.

5.6.2.1 Channelization and Resource Allocation for PUCCH Format 1/1a/1b

PUCCH Format 1/1a/1b resources are identified by a resource index $n_{PUCCH}^{(1)}$. Direct mapping between the PUCCH cyclic shifts and the resource indexes cannot be used with PUCCH Format 1/1a/1b due to the block spreading operation. Instead, PUCCH channelization is used to configure the resource blocks for PUCCH Format 1/1a/1b. The purpose of the channelization is to provide a number of parallel channels per resource block with optimized and adjustable orthogonality properties. Format 1/1a/1b channelization structure is configured by means of broadcasted system parameter, *Delta_shift*.

The number of PUCCH format 1/1a/1b resources per resource block, denoted as $N_{PUCCH\ Format\ 1}^{RB}$, can be calculated as follows:

$$N_{PUCCH\ Format\ 1}^{RB} = \frac{N_{RS}^{PUCCH} * 12}{Delta\ shift} \tag{5.1}$$

where the *Delta_shift* parameter is the cyclic shift difference between two adjacent ACK/NACK resources using the same orthogonal cover sequence [11], and parameter N_{RS}^{PUCCH} is the number of reference signals on PUCCH Format 1/1a/1b ($N_{RS}^{PUCCH} = 3$ with normal CP and 2 with extended CP). Three values are allowed for the *Delta_shift* parameter, namely 1, 2 or 3. This means that the number of PUCCH Format 1/1a/1b resources per resource block equals 36, 18 or 12, with normal CP length.

An example of the PUCCH channelization within the resource block following the staggered resource structure is shown in Figure 5.20. In this example, *Delta_shift* is set to 2 and normal CP length is assumed.

The configuration of the PUCCH Format 1/1a/1b resource is shown in Figure 5.21. PUCCH Format 1/1a/1b resources are divided into available PUCCH resource blocks and are subject to

Cyclic shift	Orthogonal cover code		
	0	1	2
0	0		12
1		6	
2	1		13
3		7	
4	2		14
5		8	
6	3		15
7		9	
8	4		16
9		10	
10	5		17
11		11	

Figure 5.20 Principle of Format 1/1a/1b channelization within one resource block, *Delta_shift*=2, normal CP

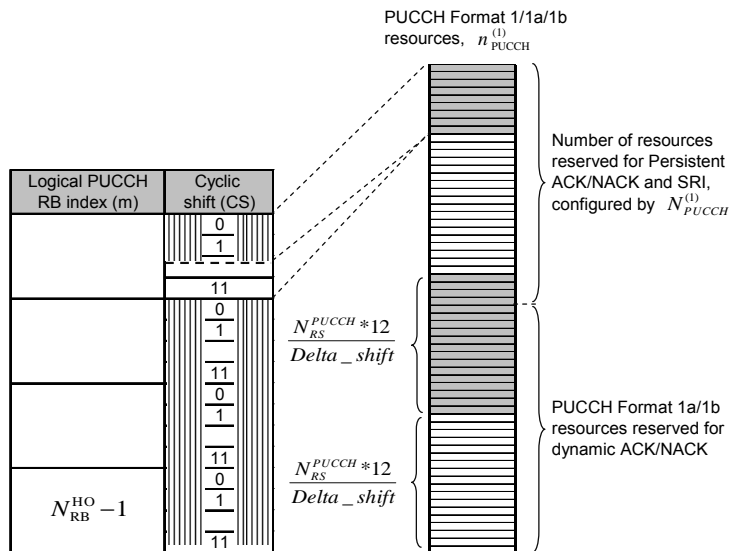

Figure 5.21 Configuration of PUCCH Format 1/1a/1b resource

channelization within the resource block as described earlier. Before that, the Format 1/1a/1b resource is split into persistent and dynamic parts. This is achieved using the broadcasted system parameter $N_{PUCCH}^{(1)}$, which is the number of resources reserved for persistent Format 1/1a/1b resources. These resources are used by the SRI and ACK/NACK related to persistently scheduled PDSCH. Both resources are allocated explicitly by resource index $n_{PUCCH}^{(1)}$. Dynamic Format 1/1a/1b resources are placed at the end of logical PUCCH resources. Allocation of these ACK/NACK resources, which relate to dynamically scheduled PDSCH, is made implicitly based on the PDCCH allocation.

The idea of implicit allocation in dynamic ACK/NACK resources is to have one-to-one mapping to the lowest PDCCH Control Channel Element (CCE) index. The total number of CCEs depends on the system bandwidth and the number of OFDM symbols allocated for control signaling in a downlink subframe, which is signaled in each subframe using PCFICH (1, 2 or 3 OFDM symbols/subframe for bandwidths above 1.4 MHz, with 2, 3 or 4 OFDM symbols occupied for 1.4 MHz). There has to be a dedicated ACK/NACK resource for each CCE. This means that, for example, with a 20 MHz system bandwidth the number of CCEs can be up to 80 if three OFDM symbols are allocated for control signaling in a subframe.

5.6.2.2 Mapping of Logical PUCCH Resource Blocks into Physical PUCCH Resource Blocks

Mapping of logical resource blocks, denoted as m , into physical PUCCH resource blocks is shown in Figure 5.22. Taking into account the logical split between different PUCCH Formats, we note that PUCCH Format 2/2a/2b is located at the outermost resource blocks of the system bandwidth. ACK/NACK reserved for persistently scheduled PDSCH and SRI are located on the PUCCH resource blocks next to periodic CQI while the ACK/NACK resources reserved for dynamically scheduled PDSCH are located at the innermost resource blocks reserved for PUCCH.

An interesting issue from the system perspective is the fact that PUCCH defines the uplink system bandwidth. This is because PUCCH always exists and is located at both edges of the frequency spectrum. We note that proper PUCCH configuration allows narrowing down the active uplink system bandwidth by the resolution of two resource blocks. This can be made so that the PUCCH Format 2/2a/2b resource is over-dimensioned and at the same time the pre-defined PUCCH Format 2/2a/2b resources placed at the outermost resource blocks are left unused. Figure 5.23 shows the principle of this configuration.

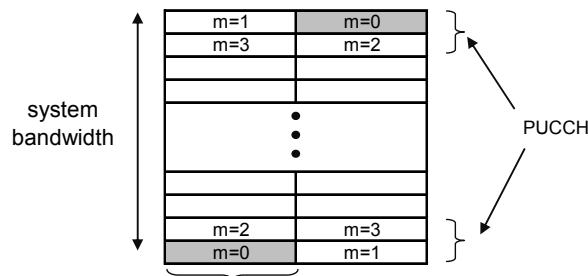

Figure 5.22 Mapping of logical PUCCH RBs into physical RBs [1]

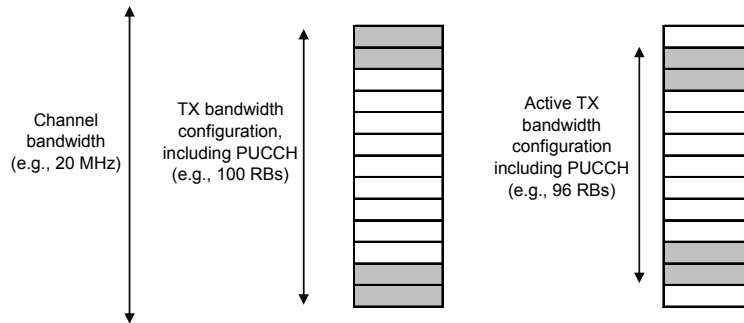

Figure 5.23 Changing the uplink system bandwidth via PUCCH configuration

5.6.3 Control Signaling on PUSCH

PUSCH carries the uplink L1/L2 control signals in the presence of uplink data. Control signaling is realized by a dedicated control resource, which is valid only during the uplink subframe when UE has been scheduled for data transmission on PUSCH. The main issues related to control signal design on PUSCH are:

- how to arrange multiplexing between uplink data and different control fields;
- how to adjust the quality of L1/L2 signals transmitted on PUSCH.

Figure 5.24 shows the principle of control and data multiplexing within the SC-FDMA symbol (block). To maintain the single carrier properties, transmitted signal data and different control symbols are multiplexed prior to the DFT. Data and different control fields (ACK/NAK, CQI/Pre-coding Matrix Indicator [PMI], Rank Indicator [RI]) are coded and modulated separately before multiplexing them into the same SC-FDMA symbol block. Block level multiplexing was also considered, but would have resulted in too large a control overhead [12]. Using the selected symbol level multiplexing scheme the ratio between the data symbols and control symbols can be accurately adjusted within each SC-FDMA block.

Figure 5.25 shows the principle of how uplink data and different control fields are multiplexed on the PUSCH. The actual mix of different L1/L2 control signals and their size vary from subframe to subframe. Both the UE and the eNodeB have the knowledge about the number of symbols reserved by the control part. The data part of PUSCH is punctured by the number of control symbols allocated in the given subframe.

Control and data multiplexing is performed so that control is present at both slots of the subframe. This guarantees that control channels can benefit from frequency hopping when it is

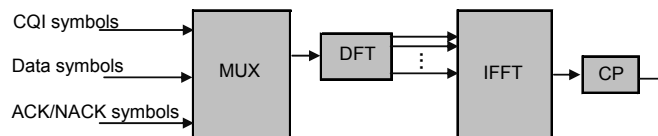

Figure 5.24 Principle of data and control modulation

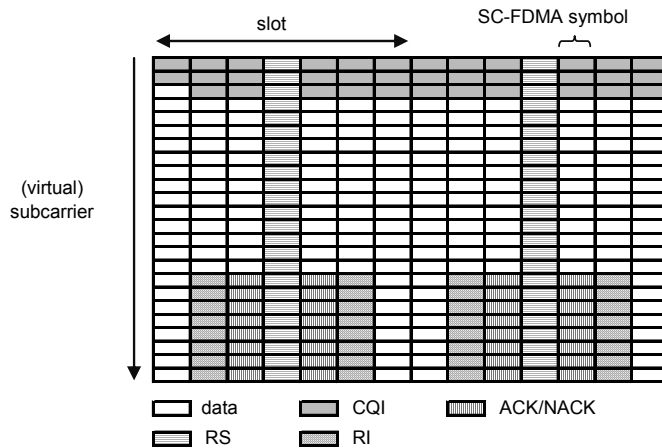

Figure 5.25 Allocation data and different control fields on PUSCH

applied. ACK/NACK is placed at the end of SC-FDMA symbols next to the reference signals. There is a maximum of 2 SC-FDMA symbols per slot allocated to ACK/NACK signaling. The same applies to RI, which is placed on the SC-FDMA symbols next to ACK/NACK. CQI/PMI symbols are placed at the beginning of the SC-FDMA symbols and they are spread over all the available SC-FDMA symbols.

CQI/PMI transmitted on PUSCH uses the same modulation scheme as the data part. ACK/NACK and RI are transmitted so that the coding, scrambling and modulation maximize the Euclidean distance at the symbol level. This means that a modulation symbol used for a ACK/NACK carrier is at most 2 bits of coded control information regardless of the PUSCH modulation scheme. The outermost constellation points having the highest transmission power are used to signal the ACK/NACK and RI for 16QAM and 64QAM. This selection provides a small power gain for ACK/NACK and RI symbols, compared to PUSCH data using higher order modulation.

Four different channel coding approaches are applied with control signals transmitted on PUSCH:

- repetition coding only: 1-bit ACK/NACK;
- simplex coding: 2-bit ACK/NACK/RI;
- (32, N) Reed–Muller block codes: CQI/PMI <11 bits;
- tail-biting convolutional coding (1/3): CQI/PMI \geq 11 bits.

An important issue related to control signaling on PUSCH is how to keep the performance of control signaling at the target level. It is noted that power control will set the SINR target of PUSCH according to the data channel. Therefore, the control channel has to adapt to the SINR operation point set for data.

One way to adjust the available resources would be to apply different power offset values for data and different control parts. The problem of the power offset scheme is that single carrier properties are partially destroyed [13]. Therefore this scheme is not used in the LTE uplink

system. Instead, a scheme based on a variable coding rate for the control information is used. This is achieved by varying the number of coded symbols for control channel transmission. To minimize the overall overhead from the control signaling, the size of physical resources allocated to control transmission is scaled according to PUSCH quality. This is realized so that the coding rate to be used for control signaling is given implicitly by the Modulation and Coding Scheme (MCS) of PUSCH data. The linkage between data MCS and the size of the control field is made according to Equation 5.2 [14]:

$$O' = \left\lceil \frac{O \cdot \text{offset} \cdot M_{SC}^{PUSCH} \cdot N_{symb}^{PUSCH}}{K_{bits}^{PUSCH}} \right\rceil, \quad (5.2)$$

where O' is the number of coded control symbols for the given control type, O is the number of control signaling bits, K_{bits}^{PUSCH} is the number of transmitted bits after code block segmentation and $M_{SC}^{PUSCH} \cdot N_{symb}^{PUSCH}$ is the total number of sub-carriers per subframe carrying PUSCH. Offset is a semi-statically configured parameter related to the coding rate adjustment of control channel and is used to achieve a desired B(L)ER operation point for a given control signaling type. $\lceil \cdot \rceil$ is the operation rounding the control channel size to the nearest supported integer value, towards plus infinity.

As mentioned, the offset-parameter is used to adjust the quality of control signals for the PUSCH data channel. It is a UE-specific parameter configured by higher layer signaling. Different control channels need their own offset-parameter setting. There are some issues that need to be taken into account when configuring the offset-parameter:

- BLER operation point for the PUSCH data channel;
- B(L)ER operation point for the L1/L2 control channel;
- difference in coding gain between control and data parts, due to different coding schemes and different coding block sizes (no coding gain with 1-bit ACK/NACK);
- DTX performance.

Different BLER operation points for data and control parts are because HARQ is used for the data channels whereas the control channels do not benefit from HARQ. The higher the difference in the BLER operation point between data and control channels, the larger is the offset parameter (and vice versa). Similar behavior relates also to the packet size. The highest offset values are needed with ACK/NACK signals due to the lack of coding gain.

5.6.4 Uplink Reference Signals

In addition to the control and data signaling, there are reference signals as discussed in Section 5.4. The eNodeB needs to have some source of known data symbols to facilitate coherent detection, like in the WCDMA where uplink Physical Dedicated Control Channel (PDCCH) was carrying pilot symbols in the uplink direction. In LTE uplink, reference signals (RS) are used as demodulation reference signals (DM RS) on PUCCH and PUSCH. The new purpose of the reference signals, not part of WCDMA operation, is to use them as sounding reference signals (SRS). Additionally, reference signals are used for sequence modulation on PUCCH as discussed in section 5.6.1.1. The sequences used as reference signals are discussed in section

5.6.4.1, while demodulation reference signals and sounding reference signals are considered in sections 5.6.4.2 and 5.6.4.3, respectively.

5.6.4.1 Reference Signal Sequences

Considering first the sequences itself, the most important properties for the RS sequences in LTE uplink are:

- favorable auto- and cross-correlation properties;
- sufficient number of sequences;
- flat frequency domain representation facilitating efficient channel estimation;
- low cubic metric values comparable to the cubic metric of QPSK modulation.

The sequences also need to be suitable for supporting the numerous bandwidth options in uplink allocations. This means that sequences of various lengths, multiples of 12, are needed.

Constant Amplitude Zero Autocorrelation Codes (CAZAC) such as Zadoff–Chu [15] and Generalized Chirp-Like [16] polyphase sequences have most of the required properties. There exist also a reasonable number of Zadoff–Chu sequences when the sequence length is a prime number. However, the sequence lengths needed in LTE uplink are multiples of 12, for which only a modest number of Zadoff–Chu sequences exist. To obtain a sufficient number of RS sequences, computer generated sequences are used for sequence lengths of 12 and 24. They are constructed from QPSK alphabet in frequency domain. Longer sequences are derived from Zadoff–Chu sequences with length of prime number. They are circularly extended in frequency domain to the desired length. These sequences are frequently referred to as extended Zadoff–Chu sequences.

As a result, there are 30 reference signal sequences available for sequence lengths of 12, 24, and 36 and a larger number for longer sequence lengths. The RS sequences do not have constant amplitude in time and, thus, they are not actually CAZAC sequences. However, they have acceptable cubic metric values and zero autocorrelation and, thus, may be referred to as Zero Autocorrelation (ZAC) sequences.

As said, the RS sequences have a periodic autocorrelation function that is zero except for the zero shift value. In other words, the cyclic, or circular, shifts of a sequence, illustrated in Figure 5.26, are orthogonal to each other. This provides a convenient means to derive multiple orthogonal sequences from a single RS sequence, which is used in LTE to multiplex UE. To maintain the orthogonality, however, the time difference between the signals arriving at the base station should not exceed the time interval corresponding to the cyclic shift separation. To accommodate multi-path delay spread, the minimum time separation between the cyclic shifts available in LTE is $5.56\mu\text{s}$ for Demodulation RS (DMRS) and $4.17\mu\text{s}$ for Sounding RS (SRS). Correspondingly, there are 12 and 8 cyclic shifts specified for DMRS and SRS, respectively, with constant time separation between cyclic shifts irrespective of the reference signal bandwidth.

5.6.4.2 Demodulation Reference Signals

DMRS are primarily used for channel estimation needed for coherent detection and demodulation and it has the same bandwidth as the uplink data transmission. There is one DMRS in every

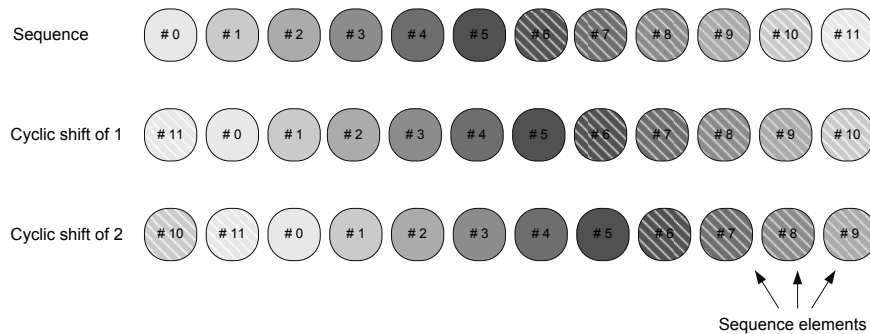

Figure 5.26 Cyclic shifts of a sequence

0.5 ms slot on PUSCH, whereas on PUCCH, there are 2–3 reference signals per slot depending on the used PUCCH format. For PUSCH, DMRS occupies the 4th SC-FDMA symbol in the slot, and the RS sequence length equals the number of allocated sub-carriers. The reference signal locations for PUCCH are discussed in section 5.6.1

As said, there are RS sequences of numerous lengths with 30 or more sequences for each sequence length. For simplicity, the sequences of various lengths are grouped into 30 sequence groups. Each sequence group contains RS sequences for all supported sequence lengths, with one RS sequence for allocations from 1 to 5 PRBs and two RS sequences for larger allocations. As a result, the used demodulation reference signal is defined with four parameters:

- sequence group, with 30 options – this is a cell specific parameter;
- sequence, with 2 options for sequence lengths of 6 PRBs or longer – this is a cell specific parameter;
- cyclic shift, with 12 options – this has both terminal and cell specific components, and 8 different values can be configured with the uplink allocation;
- sequence length, given by the uplink allocation.

Cyclic shifts are used to multiplex reference signals from different terminals within a cell, whereas different sequence groups are typically used in neighboring cells. While cyclic shifts provide good separation within a cell, a more complicated interference scenario is faced between cells. Simultaneous uplink allocations on neighboring cells can have different bandwidths and can be only partially overlapping in frequency. This alone prevents effective optimization of RS cross-correlations between cells. Thus, multiple hopping methods are included to LTE to randomize inter-cell interference for reference signals. The pseudo-random hopping patterns are cell specific and derived from the physical layer cell identity. For PUSCH and PUCCH, LTE supports:

- Cyclic shift hopping, which is always used. A cell specific cyclic shift is added on top of UE specific cyclic shifts. Cyclic shift hops for every slot on PUSCH. Inter-cell interference is expected to be more significant on PUCCH than on PUSCH due to CDM applied on PUCCH. To enhance inter-cell interference randomization, cyclic shift hops for every SC-FDMA symbol on PUCCH. Cyclic shift hopping is applied also for SC-FDMA symbols carrying control data due to the sequence modulation used on PUCCH.

- Sequence group hopping. Sequence group hopping pattern is composed of a group hopping pattern and a sequence-shift. The same group hopping pattern is applied to a cluster of 30 cells. To differentiate cells within a cluster, a cell specific sequence shift is added on top of the group hopping pattern. With this arrangement, the occasional use of the same sequence group simultaneously on neighboring cells is avoided within the cell cluster. Sequence group hopping can be also disabled, thus facilitating sequence planning. Sequence group hops for every slot.
- Sequence hopping, which means hopping between the two sequences within a sequence group. Sequence hopping can be applied for resource allocations larger than 5 RBs if sequence group hopping is disabled and sequence hopping is enabled.

On PUSCH, it is possible to configure cyclic shift hopping and sequence group hopping patterns so that the same patterns are used on neighboring cells. This means that the same sequence group is used on neighboring cells. This is not a feasible solution for PUCCH, however, due to a more intensive use of cyclic shifts. Thus, the hopping patterns are cell-specific and are derived from the cell identity on PUCCH. Therefore, a sequence group is configured separately for PUCCH and PUSCH with an additional configuration parameter for PUSCH.

5.6.4.3 Sounding Reference Signals

SRS is used to provide information on uplink channel quality on a wider bandwidth than the current PUSCH transmission or when a terminal has no transmissions on PUSCH. Channel is estimated on eNodeB and the obtained channel information can be used in the optimization of uplink scheduling as part of the uplink frequency domain scheduling operation. Thus, SRS is in a sense an uplink counterpart for the CQI reporting of downlink channel. SRS can also be used for other purposes, e.g. to facilitate uplink timing estimation for terminals with narrow or infrequent uplink transmissions. SRS is transmitted on the last SC-FDMA symbol of the subframe, as shown in Figure 5.27. Note that the SRS transmission does not need to be in the frequency area used by the PUSCH for actual data transmission but it may locate elsewhere as well.

On SRS, distributed SC-FDMA transmission is used. In other words, UE uses every second sub-carrier for transmitting the reference signal, as illustrated in Figure 5.28. Related sub-carrier offset defines a transmission comb for the distributed transmission. The transmission comb provides another means to multiplex UE reference signals in addition to the cyclic shifts. SRS

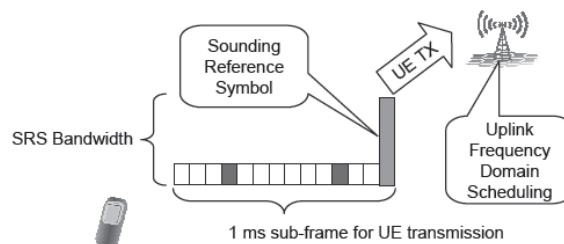

Figure 5.27 Sounding reference signal transmission in the frame

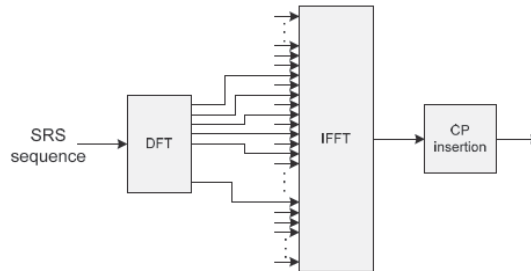

Figure 5.28 Sub-carrier mapping for sounding reference signal

uses the same sequences as DMRS. SRS sequence lengths are multiples of 24, or, correspondingly, SRS bandwidths are multiples of 4 RBs. This follows from the available RS sequence lengths combined with the definition of 8 cyclic shifts for SRS.

SRS transmissions can be flexibly configured. SRS transmission can be a single transmission or periodic with period ranging from 2 ms to 320 ms. There can be up to four different SRS bandwidth options available, depending on the system bandwidth and cell configuration. SRS transmission can also hop in frequency. This is particularly beneficial for the terminals on the cell edge, which cannot support wideband SRS transmissions. Frequency hopping can also be limited to a certain portion of system bandwidth which is beneficial for inter-cell interference coordination [17]. SRS configuration is explicitly signaled via terminal specific higher layer signaling.

Sounding reference signal transmissions from different terminals can be multiplexed in multiple dimensions:

- Time: Periodic SRS transmissions can be interleaved into different subframes with subframe offsets.
- Frequency: To facilitate frequency division multiplexing, the available SRS bandwidths follow a tree structure. This is illustrated in Figure 5.29, where a set of available SRS bandwidths is shown for a certain cell configuration. The SRS frequency hopping pattern also follows the tree structure, as shown in Figure 5.30 with an illustrative example based on the SRS bandwidth set of Figure 5.29.
- With cyclic shifts: Up to 8 cyclic shifts can be configured. The cyclic shift multiplexed signals, however, need to have the same bandwidth to maintain orthogonality. Due to the intensive use of cyclic shifts, the sequence group configured for PUCCH is used also for SRS.
- Transmission comb in the distributed transmission: Two combs are available. Contrary to cyclic shifts, transmission comb does not require that the multiplexed signals occupy the same bandwidth.

In addition to the terminal specific SRS configuration, cell specific SRS configuration defines the subframes that can contain SRS transmissions as well as the set of SRS bandwidths available in the cell. Typically SRS transmissions should not extend into the frequency band reserved for PUCCH. Therefore, multiple SRS bandwidth sets are needed for supporting flexible cell specific PUCCH configuration.

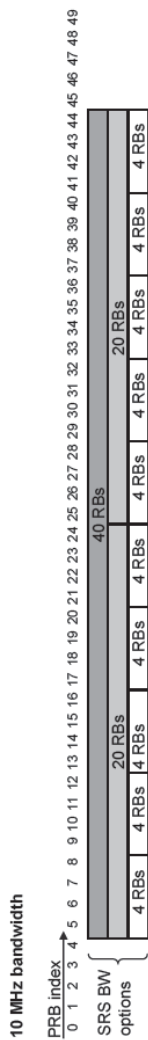

Figure 5.29 A SRS bandwidth set with a tree structure

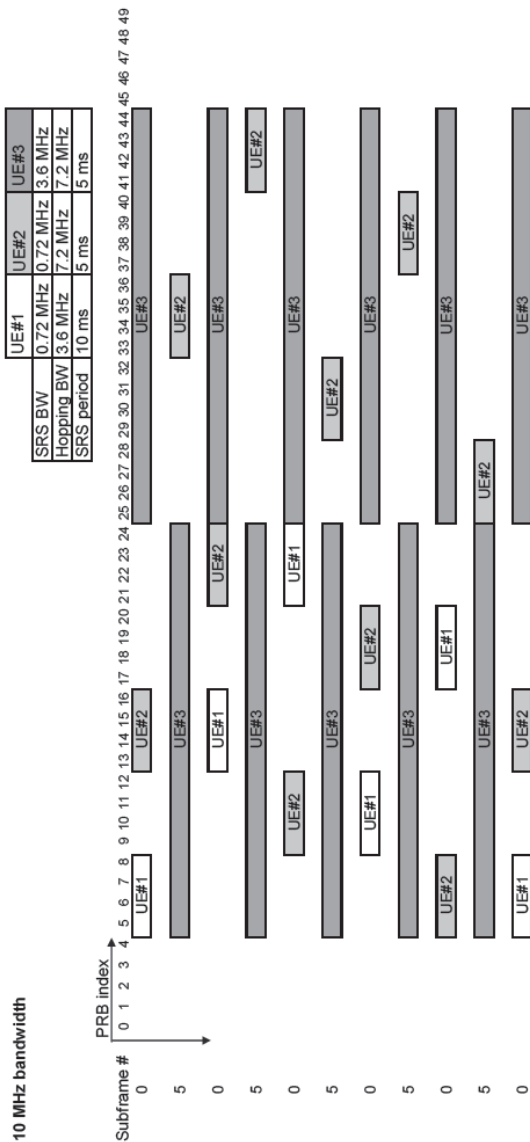

Figure 5.30 An example of SRS frequency hopping patterns

5.7 PRACH Structure

5.7.1 Physical Random Access Channel

Random access transmission is the only non-synchronized transmission in the LTE uplink. Although the terminal synchronizes to the received downlink signal before transmitting on RACH, it cannot determine its distance from the base station. Thus, timing uncertainty caused by two-way propagation delay remains on RACH transmissions.

Appropriately designed Physical Random Access Channel (PRACH) occurs reasonably frequently, provides a sufficient number of random access opportunities, supports the desired cell ranges in terms of path loss and uplink timing uncertainty, and allows for sufficiently accurate timing estimation. Additionally, PRACH should be configurable to a wide range of scenarios, both for RACH load and physical environment. For example, LTE is required to support cell ranges up to 100km, which translates to $667\mu\text{s}$ two-way propagation delay, as facilitated in the timing advance signaling range in the MAC layer.

In a LTE frame structure type 1 (FDD), only one PRACH resource can be configured into a subframe. The periodicity of PRACH resources can be scaled according to the expected RACH load, and PRACH resources can occur from every subframe to once in 20ms. PRACH transmission is composed of a preamble sequence and a preceding cyclic prefix with four different formats as shown in Figure 5.31. Multiple preamble formats are needed due to the wide range of environments. For example, the long CP in preamble formats 1 and 3 assists with large cell ranges in terms of increased timing uncertainty tolerance whereas repeated preamble sequences in formats 2 and 3 compensate for increased path loss. The guard period that is necessary after an unsynchronized preamble is not explicitly specified, but PRACH location in the subframe structure provides a sufficient guard period. Particular considerations are needed only in very special cases. For each cell, 64 preamble sequences are configured and, thus, there are 64 random access opportunities per PRACH resource. PRACH occupies 1.08MHz bandwidth, which provides reasonable resolution for timing estimation.

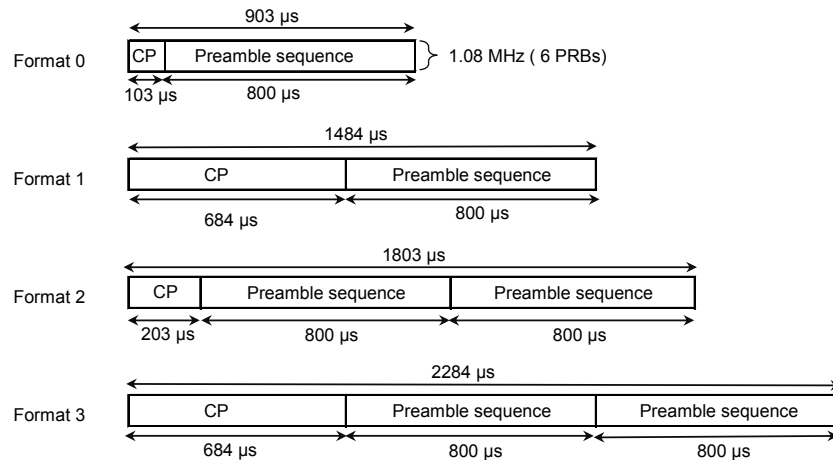

Figure 5.31 LTE RACH preamble formats for FDD

5.7.2 Preamble Sequence

Zadoff–Chu sequences [15] belonging to CAZAC are used as RACH preamble sequences due to several desirable sequence properties:

- They have a periodic autocorrelation function that is zero except for the zero shift value. This is desirable for preamble detection and timing estimation. Additionally, the cyclic, or circular, shifts of a sequence are orthogonal to each other. As a result, multiple preamble sequences are obtained from a single Zadoff–Chu sequence with cyclic shifts.
- As the preamble sequence length is set to a prime number of 839, there are 838 sequences with optimal cross-correlation properties.
- Sequences also have reasonable cubic metric properties.

The cyclic shifts used as different preambles need to have a sufficient separation. The cyclic shift separation needs to be sufficiently wide to accommodate the uplink timing uncertainty, as illustrated in Figure 5.32. The propagation delay and, thus, the cyclic separation are directly related to the cell range. To accommodate the wide range of cell ranges supported by LTE, 16 different cyclic shift separations can be configured for a cell, providing 1 to 64 preambles from a single Zadoff–Chu sequence.

A particular high speed mode, or a restricted set, is defined for RACH due to the peculiar properties of Zadoff–Chu sequences for Doppler spread. Essentially, high speed mode is a set of additional restrictions on the cyclic shifts that can be used as preambles.

Discrete Fourier Transform of Zadoff–Chu sequence is also a Zadoff–Chu sequence defined in frequency. Due to the Doppler, the transmitted preamble sequence spreads on cyclic shifts adjacent in frequency to the transmitted cyclic shift and particularly on the cyclic shift neighboring the transmitted cyclic shift in frequency. Particularly, a Doppler frequency corresponding to the inverse of sequence length, i.e. 1.25kHz for LTE, transforms the transmitted cyclic shift (of sequence) completely to the cyclic shift neighboring the transmitted one in frequency. As a result, the received sequence is orthogonal with the transmitted sequence for a Doppler frequency of 1.25kHz.

There is a tractable one-to-one relation between the cyclic shifts neighboring each other in frequency and the cyclic shifts in time. Thus, three uplink timing uncertainty windows can be defined for a preamble, with the windows separated by a shift distance as shown in Figure 5.33. The shift distance is a function of the Zadoff–Chu sequence index. The shifting of the timing uncertainty windows is circular, as illustrated in Figure 5.33.

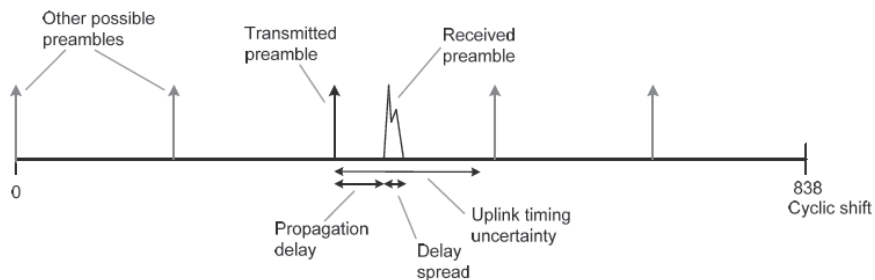

Figure 5.32 Illustration of cyclic shift separation N_{cs} between preamble sequences

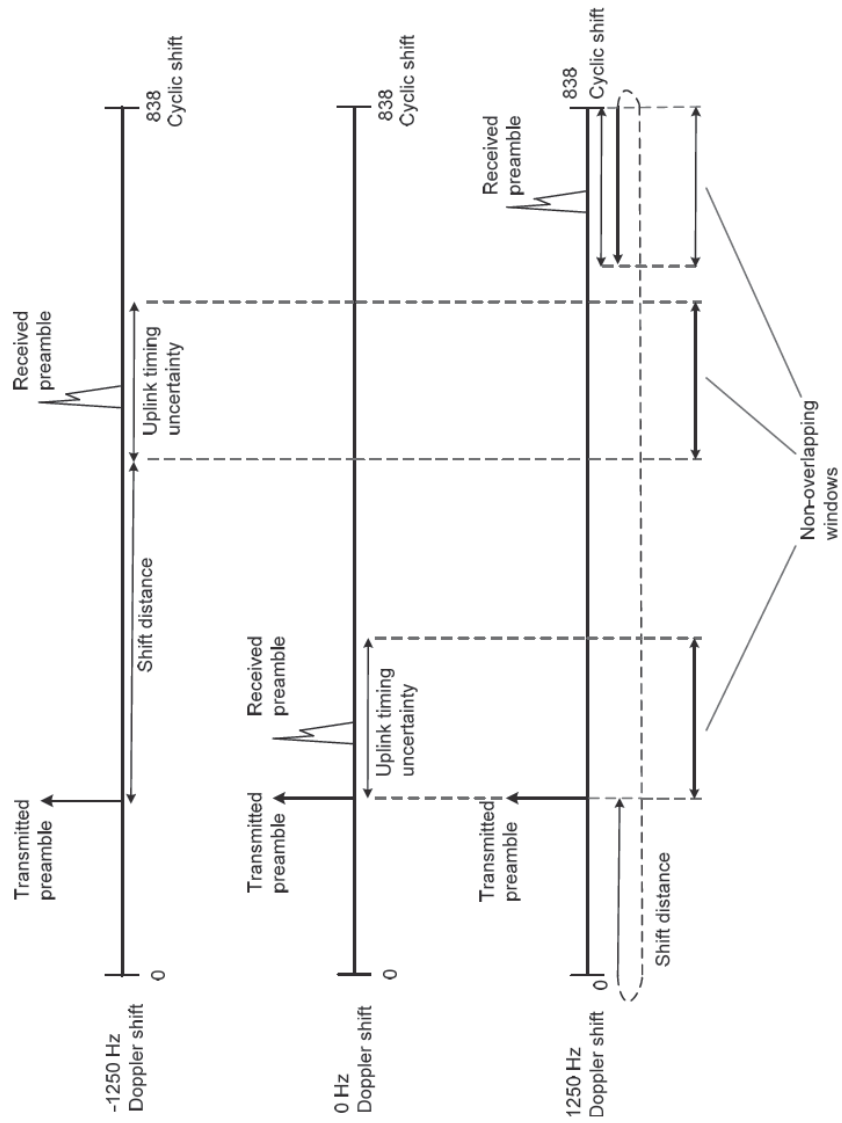

Figure 5.33 Illustration of uplink timing uncertainty windows for RACH preamble with considerable Doppler

There are several consequences of the aforementioned when detecting preambles with considerable Doppler:

- Signal energy needs to be collected from all three windows for reliable preamble detection.
- The windows of a preamble should not overlap each other to allow for initial uplink timing estimation.
- The windows of the different preambles should not overlap each other to prevent unnecessary false alarms.

As a result, the preamble cyclic shifts for high speed mode need to be selected so that the timing uncertainty windows do not overlap each other for each preamble as well as between preambles. Although these requirements, as well as the dependency of the shift distance on the sequence index, complicate the calculation of cyclic shift for preambles, tractable equations have been found and standardized [18].

5.8 Downlink Physical Layer Signaling Transmission

The control information in the downlink direction is carried using three different types of control messages:

- Control Format Indicator (CFI), which indicates the amount of resources devoted to control channel use. CFI is mapped to the Physical Control Format Indicator Channel (PCFICH).
- HARQ Indication (HI), which informs of the success of the uplink packets received. The HI is mapped on the Physical HARQ Indicator Channel (PHICH).
- Downlink Control Information (DCI), which controls with different formats basically all the physical layer resource allocation in both uplink and downlink direction and has multiple formats for different needs. The DCI is mapped on the Physical Downlink Control Channel (PDCCH)

5.8.1 Physical Control Format Indicator Channel (PCFICH)

The sole purpose of PCFICH is to dynamically indicate how many OFDMA symbols are reserved for control information. This can vary between 1 and 3 for each 1 ms subframe. From the PCFICH, UE knows which symbols to treat as control information. Location and modulation of PCFICH is fixed. The use of dynamic signaling capability allows the system to support both a large number of low data rate users (e.g. VoIP) as well as to provide sufficiently low signaling overhead when higher data rates are used by fewer simultaneously active users. The extreme situations are illustrated in Figure 5.34, where the PDCCH allocation is changed from 1 symbol to 3 symbols. When calculating the resulting overhead, note that PDCCH is only allocated to the first 0.5 ms slot in the 1 ms subframe, thus the overhead is from 1/14 to 3/14 of the total physical layer resource space.

With the 1.4MHz operation, the PDCCH resource is 2, 3 or 4 symbols to ensure enough payload size and a sufficient range for all signaling scenarios. In big cells it is important to have enough room for channel coding together with signaling, especially for the operation with RACH.

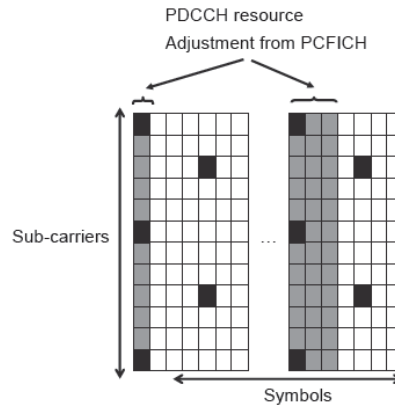

Figure 5.34 PDCCH resource allocation from PCFICH for bandwidths above 1.4 MHz

5.8.2 Physical Downlink Control Channel (PDCCH)

The UE will obtain from the PDCCH information for both uplink and downlink resource allocations the UE may use. The DCI mapped on the PDCCH has different formats and depending on the size DCI is transmitted using one or more Control Channel Elements (CCEs). A CCE is equal to 9 resource element groups. Each group in turn consists of 4 resource elements. The different PDCCH formats are shown in Table 5.2, where it can be seen that as PDCCH is using QPSK modulation, then a single resource element carries 2 bits and there are 8 bits in a resource element group.

The UE will listen to the set of PDCCHs and tries to decode them (checking all formats) in all subframes except during the ones where DRX is configured. The set of PDCCHs to monitor is up to 6 channels. Depending on the network parameterization, some of the PDCCHs are so-called common PDCCHs and may also contain power control information.

The DCI mapped to PDCCH has four different formats and further different variations for each format. It may provide the control information for the following cases:

- PUSCH allocation information (DCI Format 0);
- PDSCH information with one codeword (DCI Format 1 and its variants);
- PDSCH information with two codewords (DCI Format 2 and its variants);
- Uplink power control information (DCI Format 3 and its variants)

Table 5.2 PDCCH format and their size

PDCCH format	Number of CCEs	Number of resource-element groups	Number of PDCCH bits
0	1	9	72
1	2	18	144
2	4	36	288
3	8	72	576

The PDCCH containing PDSCH related information is often referred to as the downlink assignment. The following information is carried on the downlink assignment when providing downlink resource allocation information related to PDSCH:

- Resource block allocation information. This indicates the position of the resources allocated for the user in question in the resource block domain. The allocation can be based on, for example, a bitmap pointing the given PRBs or an index of the first PRB and the number of contiguously allocated PRBs.
- The modulation and coding scheme used for downlink user data. The 5 bit signaling indicates the modulation order and the transport block size (TBS). Based on these parameters and the number of allocated resource blocks the coding rate can be derived.
- The HARQ process number needs to be signaled as the HARQ retransmission from the eNodeB point of view is asynchronous and the exact transmission instant is up to the eNodeB scheduler functionality. Without the process number the UE could confuse the different processes and combine the wrong data. This also prevents error propagation from this part if control signaling is lost for a single TTI. The number of HARQ processes was fixed to 8 in both uplink and downlink.
- A new data indicator to tell whether the transmission for the particular process is a retransmission or not. This again follows similar principles to those applied with HSDPA.
- Redundancy version is a HARQ parameter that can be used with incremental redundancy to tell which retransmission version is used.
- The power control commands for the PUCCH are also included on the PDCCH. The power control command has two bits and it can thus use 2 steps up and downwards to adjust the power.

Additionally, when MIMO operation is involved, there are MIMO specific signaling elements involved, as discussed with the MIMO in section 5.9.7.

The PDCCH containing PUSCH related information is also known as the uplink grant. The following information is carried on the uplink grant.

- Hopping flag and resource block assignment and hopping resource allocation. The number of bits for this depends on the bandwidth to be used. Uplink resource allocation is always contiguous and it is signaled by indicating the starting resource block and the size of the allocation in terms of resource blocks.
- Modulation and coding scheme and the redundancy version.
- A new data indicator, which is intended to be used for synchronizing the scheduling commands with the HARQ ACK/NACK message status.
- TPC command for scheduled PUSCH which can represent four different values.
- Cyclic shift for the Demodulation Reference Symbols – 3 bits.
- Aperiodic CQI report request.

Besides these purposes, the PDCCH can also carry power control information for several users. The options supported are both the 1 bit and 2 bit formats. The maximum number of users listening to a single PDCCH for power control purposes is N . Higher layers indicate to the device which bit or bits it needs to receive for the power control purposes.

As mentioned earlier, the PCFICH indicates the amount of resources reserved for the PDCCH with 1 ms basis. The UEs in the cell check the PCFICH and then blindly decode the PDCCH to see

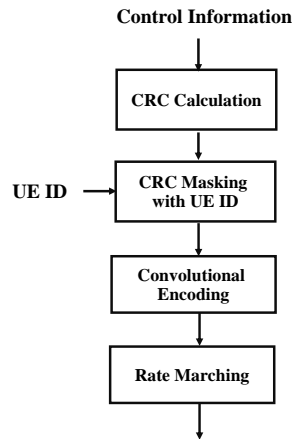

Figure 5.35 PDCCH channel coding chain

which of the control channels (if any) is intended for them. The user identification is based on using UE specific CRC, which is generated after normal CRC generation by masking the CRC with the UE ID. The PDCCH channel coding is based on the same 1/3-rate convolutional coding as other convolutionally encoding channels. The PDCCH encoding chain is illustrated in Figure 5.35.

5.8.3 Physical HARQ Indicator Channel (PHICH)

The task for the Physical HARQ Indicator Channel (PHICH) is simply to indicate in the downlink direction whether an uplink packet was correctly received or not. The device will decode the PHICH based on the uplink allocation information received on the PDCCH.

5.8.4 Downlink Transmission Modes

For robust and efficient system operation, it is important that the UE knows beforehand which type of transmission to expect. If the transmission mode could change dynamically from one subframe to another the UE would need to monitor all the possible DCI formats simultaneously, leading to a considerable increase in the number of blind decodings and receiver complexity (and possibly an increased number of signaling errors). Furthermore, the UE would not be able to provide meaningful channel feedback since, for example, the CQI value depends on the transmission mode assumed.

Therefore each UE is configured semi-statically via RRC signaling to one transmission mode. The transmission mode defines what kind of downlink transmissions the UE should expect, e.g. transmit diversity or closed loop spatial multiplexing, and restricts the channel feedback to modes corresponding to the desired operation. In LTE Release 8, seven transmission modes have been defined:

- 1 Single-antenna port; port 0
This is the simplest mode of operation with no pre-coding.

- 2 Transmit Diversity
Transmit diversity with two or four antenna ports using SFBC.
- 3 Open-loop spatial multiplexing
This is an open loop mode with the possibility to do rank adaptation based on the RI feedback. In the case of rank = 1 transmit diversity is applied similarly to transmission mode 2. With higher rank spatial multiplexing with up to four layers with large delay, CDD is used.
- 4 Closed-loop spatial multiplexing
This is a spatial multiplexing mode with pre-coding feedback supporting dynamic rank adaptation.
- 5 Multi-user MIMO
Transmission mode for downlink MU-MIMO operation.
- 6 Closed-loop Rank = 1 pre-coding
Closed loop pre-coding similar to transmission mode 5 without the possibility of spatial multiplexing, i.e. the rank is fixed to one.
- 7 Single-antenna port; port 5
This mode can be used in a beam forming operation when UE specific reference signals are in use.

5.8.5 Physical Broadcast Channel (PBCH)

The physical broadcast Channel (PBCH) carries the system information needed to access the system, such as RACH parameters, and as covered in more detail in Chapter 6. The channel is always provided with 1.08 MHz bandwidth, as shown in Figure 5.36, so the PBCH structure is independent of the actual system bandwidth being used, similar to other channels/signals needed for initial system access. The PBCH is convolutionally encoded as the data rate is not that high. As discussed in Chapter 6, the broadcast information is partly carried on the PBCH,

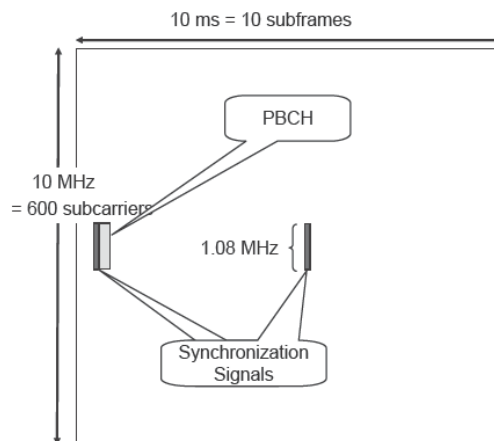

Figure 5.36 PBCH location at the center frequency

where the Master Information Block (MIB) is transmitted while the actual System Information Blocks (SIBs) are then on the PDSCH. The 600 sub-carriers in Figure 5.36 need only 9 MHz (50 resource blocks) in the resource domain but the system bandwidth needed for sufficient attenuation for the adjacent operator increases the total bandwidth needed to 10 MHz, as discussed in Chapter 11. With a 1.4 MHz system bandwidth there are no resource blocks on either side of the PBCH in the frequency domain in use, so effectively only 6 resource blocks may be in use to meet the spectrum mask requirements.

5.8.6 Synchronization Signal

There are 504 Physical Cell Identities (PCIs) values in the LTE system, compared with the 512 primary scrambling codes in WCDMA. The Primary Synchronization Signal (PSS) and the Secondary Synchronization Signals (SSS) are transmitted, similar to PBCH, always with the 1.08 MHz bandwidth, located in the end of 1st and 11th slots (slots 0 and 10) of the 10 ms frame, as shown in Figure 5.37.

The PSS and SSS jointly point the space of 504 unique Physical-layer Cell Identities (PCIs). The PCIs form 168 PCI groups, each of them having 3 PCIs (thus a total of 504 PCIs). The location and structure of the PCIs mean that taking a sample from the center frequency (with a bandwidth of 1.08 MHz) for a maximum of 5 ms contains the necessary information needed for cell identification.

5.9 Physical Layer Procedures

The key physical layer procedures in LTE are power control, HARQ, timing advance and random access. Timing advance is based on the signaling in the Medium Access Control (MAC) layer (as shown in the MAC section in Chapter 6), but as it is directly related to the physical layer, the timing advance details are covered in this chapter. The big contrast to WCDMA is that there are no physical layer issues related to macro-diversity since the UE is only connected to one base station at a time and hand handover is applied. Also, a specific means for dealing with inter-system and inter-frequency measurements such as compressed

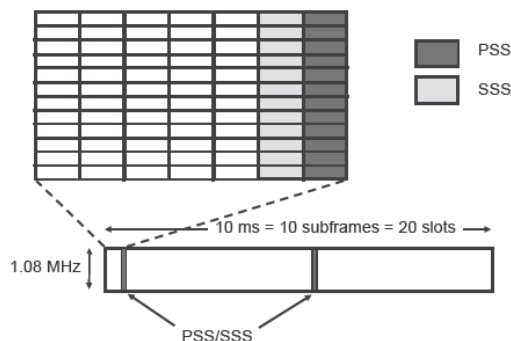

Figure 5.37 Synchronization signals in the frame

mode is not needed in LTE, as LTE by nature has a discontinuous operation that will facilitate the measurements by scheduling.

5.9.1 HARQ Procedure

The HARQ in LTE is based on the use of a stop-and-wait HARQ procedure. Once the packet is transmitted from the eNodeB, the UE will decode it and provide feedback in the PUCCH, as described in section 5.6. For negative acknowledgement (NACK) the eNodeB will send a retransmission. The UE will combine the retransmission with the original transmission and will run the turbo decoding again. Upon successful decoding (based on CRC check) the UE will send positive acknowledgement (ACK) for the eNode. After that eNodeB will send a new packet for that HARQ process. Due to the stop-and-wait way of operating, one needs to have multiple HARQ processes to enable a continuous data flow. In LTE the number of processes is fixed to 8 processes in both the uplink and downlink direction. An example of a single user continuous transmission is illustrated in Figure 5.38. For multiple users, it is dependent on the eNodeB scheduler when a retransmission is sent in the uplink or downlink direction, as a retransmission also requires that resources are allocated.

The HARQ operation in LTE supports both soft combining and the use of incremental redundancy. The use of soft combining means that retransmission has exactly the same rate matching parameters as the original transmission and thus exactly the same symbols are transmitted. For incremental redundancy, the retransmission may have different rate matching parameters like the original transmission. The minimum delay between the end of a packet and the start of a retransmission is 7 ms. The UE will send the ACK/NACK for a packet in frame n , in the uplink frame $n+4$. This leaves around 3 ms processing time for the UE, depending on the uplink/downlink timing offset controlled by the timing advance procedure. The downlink timing for a single transmitted downlink packet is shown in Figure 5.39. The retransmission instant in the downlink is subject to the scheduler in eNodeB and thus the timing shown in Figure 5.39 is the earliest moment for a retransmission to occur.

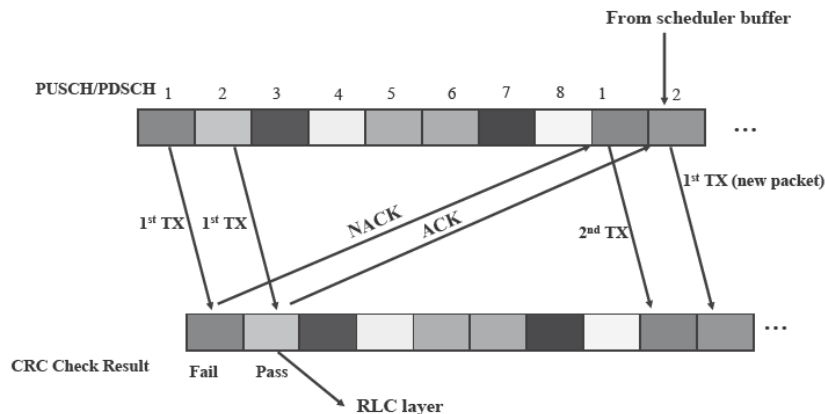

Figure 5.38 LTE HARQ operation with 8 processes

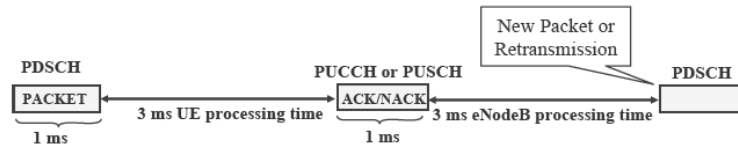

Figure 5.39 LTE HARQ timing for a single downlink packet

5.9.2 Timing Advance

The timing control procedure is needed so that the uplink transmissions from different users arrive at the eNodeB essentially within the cyclic prefix. Such uplink synchronization is needed to avoid interference between the users with uplink transmissions scheduled on the same subframe. The eNodeB continuously measures the timing of the UE uplink signal and adjusts the uplink transmission timing as shown in Figure 5.40. Timing advance commands are sent only when a timing adjustment is actually needed. The resolution of a timing advance command is $0.52 \mu\text{s}$, and timing advance is defined relative to the timing of the downlink radio frame received on UE.

The timing advance value is measured from RACH transmission when the UE does not have a valid timing advance, i.e. the uplink for the UE is not synchronized. Such situations are system access, when the UE is in RRC_IDLE state or when the UE has had an inactivity period exceeding related timer, non-synchronized handover, and after radio link failure. Additionally, eNodeB can assign to UE a dedicated (contention-free) preamble on RACH for uplink timing measurement when eNodeB wants to establish uplink synchronization. Such situations are faced with handover or when downlink data arrive for a non-synchronized UE. From the range defined for timing advance, cell sizes up to 100km would be facilitated, and even beyond by leaving some resources unused.

5.9.3 Power Control

For LTE, power control is slow for the uplink direction. In the downlink direction there is no power control. As the bandwidth varies due to data rate changes, the absolute transmission power of the UE will also change. The power control does not now actually control absolute power but rather the Power Spectral Density (PSD), power per Hz, for a particular device. What facilitates the use of a slower rate for power control is the use of orthogonal resources in the LTE uplink, which avoids the near-far problem that required fast power control in WCDMA. The key motivation for the power control is to reduce terminal power consumption and also to avoid an overly large dynamic range in the eNodeB receiver, rather than to mitigate interference. In the

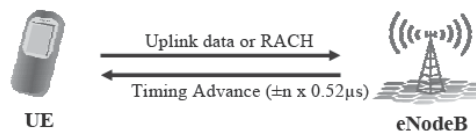

Figure 5.40 Uplink timing control

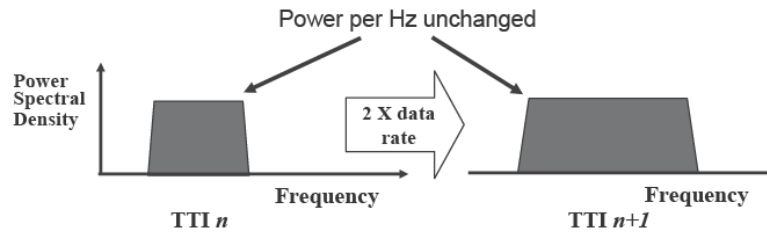

Figure 5.41 LTE uplink power with data rate change

receiver the PSDs of different users have to be reasonably close to each other so the receiver A/D converter has reasonable requirements and also the interference resulting from the non-ideal spectrum shape of the UE transmitter is kept under control. The LTE uplink power control principle is illustrated in Figure 5.41 where at the change of data rate the PSD stays constant but the resulting total transmission power is adjusted relative to the data rate change.

The actual power control is based on estimating the path loss, taking into account cell specific parameters and then applying the (accumulated) value of the correction factor received from the eNodeB. Depending on the higher layer parameter settings, the power control command is either 1 dB up or down or then the set of $[-1\text{dB}, 0, +1\text{dB}, +3\text{dB}]$ is used. The specifications also include power control that is absolute value based but, based on the text case prioritization, it is not foreseen that this will be used in the first phase networks. The total dynamic range of power control is slightly smaller than in WCDMA and the devices now have a minimum power level of -41dBm compared to -50dBm with WCDMA.

5.9.4 Paging

To enable paging, the UE is allocated a paging interval and a specific subframe within that interval where the paging message could be sent. The paging is provided in the PDSCH (with allocation information on the PDCCH). The key design criterion in paging is to ensure a sufficient DRX cycle for devices to save power and also to ensure a fast enough response time for the incoming call. The E-UTRAN may parameterize the duration of the paging cycle to ensure sufficient paging capacity (covered in more detail in Chapter 6).

5.9.5 Random Access Procedure

The LTE Random Access (RACH) operation resembles that of WCDMA because both use preambles and similar ramping of preamble power. The initial power is based on the measured path loss in DL, and power ramping is necessary because of the relatively coarse accuracy of the UE in path loss measurement and absolute power setting, and to compensate for uplink fading. Although LTE PRACH resources are separate from PUSCH and PUCCH, power ramping is useful for simultaneous detection of different preamble sequences and for minimizing the interference due to asynchronous PRACH transmission at the adjacent PUCCH and PUSCH resources. The steps of the physical layer procedure are as follows:

- Transmit a preamble using the PRACH resource, preamble sequence and power selected by MAC.
- Wait for the RACH response with matching preamble information (PRACH resource and preamble sequence). In addition to the preamble information, the response also contains the information on the uplink resource to use for further information exchange as well as the timing advance to be used. In the WCDMA RACH procedure, after acknowledging a preamble, the UE continues with a 10 or 20 ms frame duration of data, or even longer, as described for Release 8 HSPA operation in Chapter 13. The fundamental difference in LTE is that the device will move instead directly to the use of UL-SCH on reception of the random access response, which has the necessary information.
- If no matching random access response is received, transmit the preamble in the next available PRACH resource according to instructions of MAC, as shown in Figure 5.42.

Although the LTE specification models that the physical layer just transmits preambles and detects responses under the control of MAC, we describe below the complete procedure without focusing on the modeling of the specification.

Two fundamentally different random access procedures have been specified for LTE. The contention based procedure is what we normally understand with random access: UEs transmit randomly selected preambles on a common resource to establish a network connection or request resources for uplink transmission. The non-contention based random access is initiated by the network for synchronizing UE's uplink transmission, and the network can identify the UE from the very first uplink transmission. This procedure is nevertheless included under the LTE random access because it uses PRACH resources. Both procedures are common for TDD and FDD systems.

5.9.5.1 Contention and Non-contention Based Random Access

The contention based procedure follows the signaling diagram in Figure 5.43 (left half).

In the first step, the UE transmits a preamble sequence on PRACH. The details of PRACH and preamble sequences are explained in section 5.7. For each cell a total of 64 sequences are reserved, and these are grouped for the non-contention based and contention based procedures. The group reserved for the contention based procedures is divided further into two: by selecting the proper group, the UE sends one bit of information about the transport block size that the UE desires to send on PUSCH in Step 3.

In the second step, the UE receives a preamble response on DL-SCH resource that is assigned on PDCCH. The identity RA-RNTI that is used for this assignment is associated with the

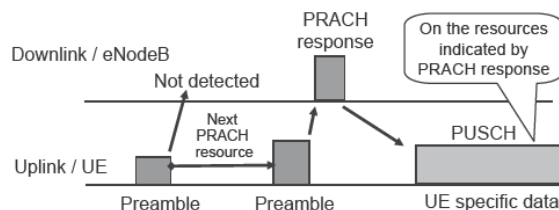

Figure 5.42 Power ramping in random access procedure

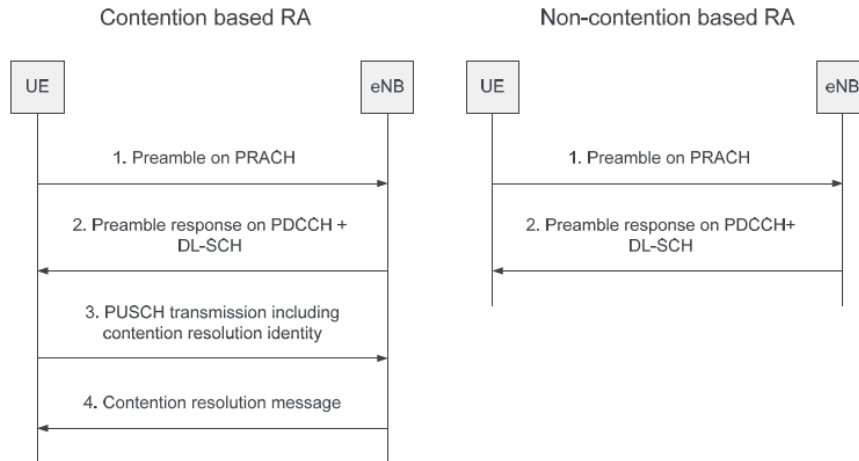

Figure 5.43 The contention and non-contention based random access procedures

frequency and time resource of the preamble. This permits bundling of the responses that are meant for preambles transmitted in the same PRACH frequency and time resource, which is important for saving PDCCH resources. eNodeB transmits the response in a time window that can be configured up to 10 ms in duration. The flexible window allows freedom for dimensioning of the RACH receiver and for scheduling of the responses.

The response (signaling part of the MAC layer as covered in Chapter 6) lists the sequence numbers of the observed preambles, and in addition the following information is given for each acknowledged preamble:

- A grant for the first transmission on PUSCH, including also information on the need for frequency hopping, power control command for uplink transmission and information on the need for CQI transmission and whether the PUSCH transmission needs to be delayed by one subframe from the nominal value.
- A timing alignment command.
- A temporary allocation for identity called temporary CRNTI, which is used for addressing PUSCH grants and DL-SCH assignments in Steps 3 and 4 of the procedure.

The typical probability of preamble collisions, meaning that two or more UEs are transmitting the same preamble sequence in the same frequency and time resource, is expected to be around 1%. These collisions are resolved in Steps 3 and 4: the UE includes its identity in the first message that it transmits on PUSCH in Step 3 and expects in Step 4 an acknowledgement that eNodeB has received the identity. There are two forms of acknowledgement: it can be either (1) a PUSCH grant or DL-SCH assignment addressed with CRNTI if the UE had included CRNTI to the message of Step 3, or (2) the UE's identity can be acknowledged with a message that is sent on a DL-SCH resource assigned with the temporary CRNTI. The first form of acknowledgement is for RRC connected UEs while the second form is used when a UE tries to establish or re-establish RRC connection. HARQ is used both in Step 3 and 4. In

Step 3 there is no difference compared with normal HARQ, but in Step 4 the UE never sends NAK, and ACK is sent only by the UE that wins the contention resolution. No special actions are taken after a lost contention resolution but the UE simply retransmits a preamble just like after failing to receive the preamble response.

The LTE network can control the RACH load rapidly. If the UE does not receive acknowledgement for its preamble in Step 2 or for its identity in Step 4, the UE retransmits the preamble with increased power if power ramp-up has been configured. Normally the retransmission can be done as soon as the UE is ready but the network can also configure a back-off parameter that forces the UE to add a random delay before the retransmission. When needed, the back-off parameter is included in the preamble response message, and the setting is obeyed by all the UE decoding the message. This allows much faster load control than in WCDMA where a similar load control parameter is in the broadcasted System Information.

The non-contention based procedure, shown in Figure 5.43 (right half), is used for time alignment during handover and when an RRC connected UE needs to be synchronized for downlink data arrival. The UE receives in the handover command or through PDCCH signaling an index of its dedicated preamble sequence, which it is allowed to transmit on PRACH. Besides the sequence index, some restrictions for the frequency and time resource can be signaled so that the same sequence can be simultaneously allocated for UEs that transmit on different PRACH subframes or, for TDD, at different PRACH frequencies. The preamble responses in the contention and non-contention based procedures are identical and they can thus be bundled to the same response message. As eNodeB knows the identity of the UE that has sent the dedicated preamble, the contention resolution with Steps 3 and 4 is not needed.

The non-contention based procedure provides delay and capacity enhancements compared with the contention based procedure. As the preamble collisions are absent and the contention resolution is not needed, a shorter delay can be guaranteed, which is especially important for handover. The sequence resource is in effective use because it is assigned to the UE only when needed and can be released as soon as eNodeB detects that the UE has received the preamble response.

An unsuccessful random access procedure ends based on preamble count or RRC timers. The preamble count is decisive only with two causes of random access: (a) an RRC connected UE, lacking scheduling request resources, asks resources because of uplink data arrival or (b) an RRC connected UE needs to be synchronized because of DL data arrival. If random access has been started because of RRC connection establishment or re-establishment or because of handover, the procedure continues until success or MAC reset in the expiry of the RRC timer corresponding to the cause of random access.

5.9.6 Channel Feedback Reporting Procedure

The purpose of the channel state feedback reporting is to provide the eNodeB with information about the downlink channel state in order to help optimize the packet scheduling decision. The principle of the channel state feedback reporting procedure is presented in Figure 5.44. The channel state is estimated by the UE based on the downlink transmissions (reference symbols, etc.) and reported to the eNodeB by using PUCCH or PUSCH. The channel state feedback reports contain information about the scheduling and link adaptation (MCS/TBS and MIMO) related parameters the UE can support in the data reception. The eNodeB can then take advantage of the feedback information in the scheduling decision in order to optimize the usage of the frequency resources.

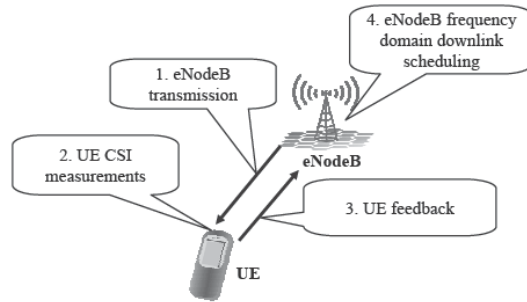

Figure 5.44 Channel State Information (CSI) reporting procedure

In general the channel feedback reported by the UE is just a recommendation and the eNodeB does not need to follow it in the downlink scheduling. In LTE the channel feedback reporting is always fully controlled by the eNodeB and the UE cannot send any channel state feedback reports without eNodeB knowing it beforehand. The corresponding procedure for providing information about the uplink channel state is called channel sounding and it is done using the Sounding Reference Signals (SRS) as presented in Section 5.6.4.3.

The main difference of the LTE channel state information feedback compared to WCDMA/HSDPA is the frequency selectivity of the reports, i.e. the information regarding the distribution of channel state over the frequency domain can also be provided. This is an enabler for Frequency Domain Packet Scheduling (FDPS), a method that aims to divide the radio resources in the frequency domain for different users so that system performance is optimized. In Figure 5.45 the gain from the FDPS is illustrated. As the UE speed increases, the CSI reports become more inaccurate and get outdated faster leading to reduced gains in high mobility.

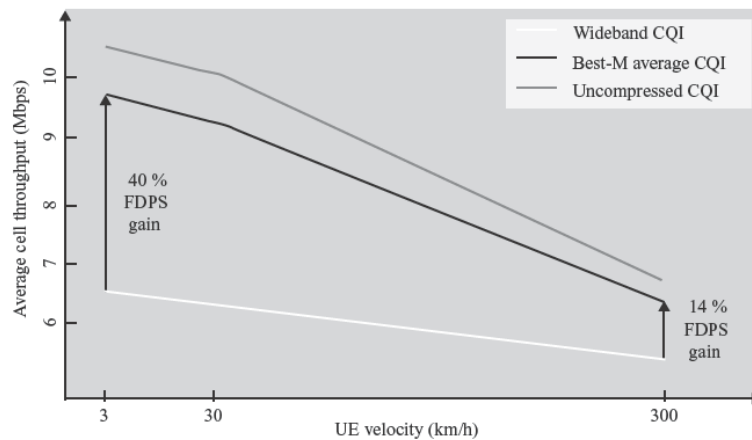

Figure 5.45 Comparison of the average cell throughputs for different CQI schemes and velocities

5.9.6.1 Channel Feedback Report Types in LTE

In LTE the UE can send three types of channel feedback information:

- CQI – Channel Quality Indicator
- RI – Rank Indicator
- PMI – Pre-coding Matrix Indicator

The most important part of channel information feedback is the Channel Quality Indicator (CQI). The CQI provides the eNodeB information about the link adaptation parameters the UE can support at the time (taking into account the transmission mode, the UE receiver type, number of antennas and interference situation experienced at the given time). The CQI is defined as a table containing 16 entries (Table 5.3) with Modulation and Coding Schemes (MCSs). The UE reports back to the eNodeB the highest CQI index corresponding to the MCS and TBS for which the estimated received DL transport block BLER shall not exceed 10%. The CQI operation has a high degree of similarity with HSDPA CQI use, as covered in [5]. Note that there are many more possibilities for MCS and TBS size values than only those 15 indicated by the CQI feedback.

Rank Indicator (RI) is the UE's recommendation for the number of layers, i.e. streams to be used in spatial multiplexing. RI is only reported when the UE is operating in MIMO modes with spatial multiplexing (transmission modes 3 and 4). In single antenna operation or TX diversity it is not reported. The RI can have values 1 or 2 with 2-by-2 antenna configuration and from 1 up to 4 with 4-by-4 antenna configuration. The RI is always associated with one or more CQI reports, meaning that the reported CQI is calculated assuming that particular RI value. Since the rank varies typically more slowly than the CQI it is normally reported less

Table 5.3 CQI table

CQI index	Modulation	Coding rate × 1024	Bits per resource element
0	out of range		
1	QPSK	78	0.1523
2	QPSK	120	0.2344
3	QPSK	193	0.3770
4	QPSK	308	0.6016
5	QPSK	449	0.8770
6	QPSK	602	1.1758
7	16QAM	378	1.4766
8	16QAM	490	1.9141
9	16QAM	616	2.4063
10	64QAM	466	2.7305
11	64QAM	567	3.3223
12	64QAM	666	3.9023
13	64QAM	772	4.5234
14	64QAM	873	5.1152
15	64QAM	948	5.5547

often. RI always describes the rank on the whole system band, i.e. frequency selective RI reports are not possible.

The PMI provides information about the preferred pre-coding matrix in codebook based pre-coding. Like RI, PMI is also relevant to MIMO operation only. MIMO operation with PMI feedback is called Closed Loop MIMO. The PMI feedback is limited to transmission modes 4, 5, and 6. The number of pre-coding matrices in the codebook depends on the number of eNodeB antenna ports: in the case of two antenna ports there are altogether six matrices to choose from, while with four antenna ports the total number is up to 64 depending on the RI and the UE capability. PMI reporting can be either wideband or frequency selective depending on the CSI feedback mode.

5.9.6.2 Periodic and Aperiodic Channel State Feedback Reporting

Although in principle the UE has up-to-date information about the changes in channel state, a channel state feedback report initiated by the UE would raise several issues. First, to detect the reports blind decoding would need to be performed at the eNodeB, which is not desirable from the receiver implementation point of view. Secondly, as the eNodeB is anyway fully in charge of the scheduling decisions, UE initiated reports would often be unnecessary. Furthermore, the reports initiated by UE would complicate the uplink resource allocation considerably, leading to increased signaling overhead. Hence it was agreed that in the LTE standardization channel state feedback reporting is always fully controlled by the eNodeB, i.e. the UE cannot send any channel state feedback reports without eNodeB knowing beforehand.

To fully exploit the gains from frequency selective packet scheduling, detailed CSI reporting is required. As the number of UEs reporting channel state feedback increases, however, the uplink signaling overhead becomes significant. Furthermore the PUCCH, which is supposed to carry primarily the control information, is rather limited in capacity: payload sizes of only up to 11 bits/subframe can be supported. On the PUSCH there are no similar restrictions on the payload size, but since PUSCH is a dedicated resource only one user can be scheduled on a single part of the spectrum.

To optimize the usage of the uplink resources while also allowing for detailed frequency selective CSI reports, a two-way channel state feedback reporting scheme has been adopted in LTE. Two main types of reports are supported: Periodic and Aperiodic. A comparison of the main features of the two reporting options is presented in Table 5.4.

Periodic reporting using PUCCH is the baseline mode for channel information feedback reporting. The eNodeB configures the periodicity parameters and the PUCCH resources via higher layer signaling. The size of a single report is limited up to about 11 bits depending on the reporting mode, and the reports contain little or no information about the frequency domain behavior of the propagation channel. Periodic reports are normally transmitted on PUCCH. If the UE is scheduled in the uplink, however, the Periodic report moves to PUSCH. The reporting period of RI is a multiple of CQI/PMI reporting periodicity. RI reports use the same PUCCH resource (PRB, Cyclic shift) as the CQI/PMI reports – PUCCH format 2/2a/2b.

When the eNodeB needs more precise channel state feedback information it can at any time request the UE to send an Aperiodic channel state feedback report on PUSCH. Aperiodic reports can be either piggybacked with data or sent alone on PUSCH. Using the PUSCH makes it possible to transmit large and detailed reports. When the transmission of Periodic and Aperiodic reports from the same UE might collide, only the Aperiodic report is sent.

Table 5.4 Comparison of Periodic and Aperiodic channel information feedback reporting

	Periodic reporting	Aperiodic reporting
When to send	Periodically every 2–160 ms	When requested by the eNodeB
Where to send	Normally on PUCCH, PUSCH used when multiplexed with data	Always on PUSCH
Payload size of the reports	4–11 bits	Up to 64 bits
Channel Coding	Linear block codes	Tail biting convolutional codes
CRC protection	No	Yes, 8 bit CRC
Rank Indicator	Sent in separate subframes at lower periodicity	Sent separately encoded in the same subframe
Frequency selectivity of the CQI	Only very limited amount of frequency information	Detailed frequency selective reports are possible
Frequency selectivity of the PMI	Only wideband PMI	Frequency selective PMI reports are possible

The two modes can also be used to complement each other. The UE can be, for example, configured to send Aperiodic reports only when it is scheduled, while Periodic reports can provide coarse channel information on a regular basis.

5.9.6.3 CQI Compression Schemes

Compared to the WCDMA/HSPA, the main new feature in the channel feedback is the frequency selectivity of the report. This is an enabler for the Frequency Domain Packet Scheduling (FDPS). Since providing a full 4-bit CQI for all the PRBs would mean excessive uplink signaling overhead of hundreds of bits per subframe, some feedback compression schemes are used.

To reduce feedback, the CQI is reported per *sub-band* basis. The size of the sub-bands varies depending on the reporting mode and system bandwidth from two consecutive PRBs up to whole system bandwidth.

The main CQI compression methods are:

- wideband feedback
- Best-M average (UE-selected sub-band feedback)
- higher layer-configured sub-band feedback.

Additionally, delta compression can be used in combination with the above options, e.g. when a closed loop MIMO CQI for the 2nd codeword can be signaled as a 3-bit delta relative to the CQI of the 1st codeword. When the number of sub-bands is large this leads to considerable savings in signaling overhead.

5.9.6.4 Wideband Feedback

The simplest way to reduce the number of CQI bits is to use only wideband feedback. In wideband feedback only a single CQI value is fed back for the whole system band. Since

no information about the frequency domain behavior of the channel is included, wideband feedback cannot be used in FDPS. Often, however, this is still sufficient, e.g. PDCCCH link adaptation or TDM-like scheduling in low loaded cells do not benefit from frequency selective CQI reporting. Also, when the number of scheduled UEs gets high, the total uplink signaling overhead due to detailed CQI reports may become excessive and the wideband CQI reports are the only alternative.

5.9.6.5 Best-M Average

Best-M average is an effective compromise between the system performance and the uplink feedback signaling overhead. The principle of the Best-M average compression is shown in Figure 5.46. In Best-M average reporting the UE first estimates the channel quality for each sub-band. Then it selects the M best ones and reports back to the eNodeB a single average CQI corresponding to the MCS/TBS the UE could receive correctly assuming that the eNodeB schedules the UE on those M sub-bands. The parameter M depends on the system bandwidth and corresponds to roughly 20% of the whole system bandwidth.

5.9.6.6 Higher Layer-configured Sub-band Feedback

In higher layer-configured sub-band feedback a separate CQI is reported for each sub-band using delta compression. This will result in the best performance at the cost of feedback overhead: the payload size of the reports can be as large as 64 bits. To keep the signaling on a manageable level, the sub-band sizes with Full Feedback reporting are twice as large as with Best-M average. This will limit the accuracy and performance in very frequency selective channels, where Best-M average may be a better alternative.

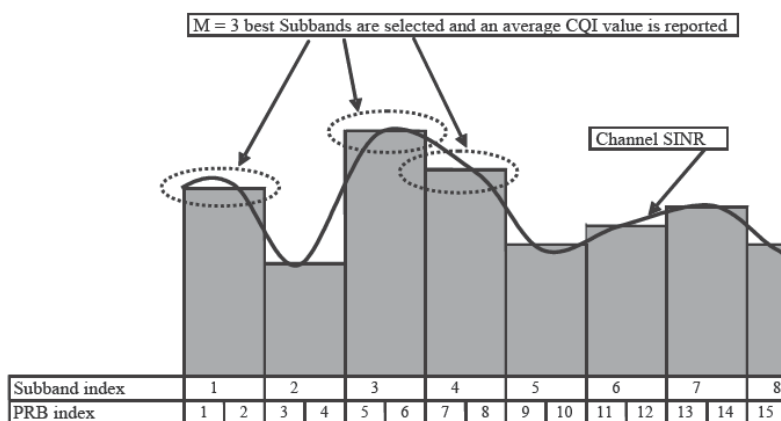

Figure 5.46 The principle of the Best-M average compression. An average CQI value is reported for the M best sub-bands

5.9.7 Multiple Input Multiple Output (MIMO) Antenna Technology

In the Release 8 LTE specifications there is support for multi-antenna operation both in terms of transmit diversity as well as spatial multiplexing with up to four layers. The use of MIMO with OFDMA has some favorable properties compared to WCDMA because of its ability to cope effectively with multi-path interference. In WCDMA, MIMO was introduced in Release 7 but has not yet been deployed. In LTE, MIMO is part of the first release and also part of the device categories with the exception of the simplest device type, as shown in section 5.9. The use of more than a single antenna in an eNodeB will not result in a problem with non-MIMO LTE devices because all devices can cope with the transmit diversity up to four antennas. Thus full transmit power can always be used regardless of the number of transmit antennas included. As shown in Chapter 4, the reference symbols are transmitted so that they have separate time and frequency domain resources for each antenna port to allow for good separation of different antennas and robust channel estimation, while the actual user data then overlap in the time and frequency domains.

Perhaps the most attractive mode of MIMO operation is spatial multiplexing, which allows an increase in the peak rates compared to the non-MIMO case by a factor of 2 or 4, depending on the eNodeB and the UE antenna configuration. In LTE the MIMO modes supporting spatial multiplexing are:

- Transmission mode 3 – Open-loop spatial multiplexing. The UE reports the RI but no pre-coding feedback. Based on the RI the eNodeB scheduler can select the number of layers used in spatial multiplexing. In the case of rank = 1, TX diversity is used. With a higher rank, large delay CDD is applied with deterministic pre-coding.
- Transmission mode 4 – Closed-loop spatial multiplexing. Here the UE reports both the RI and index of the preferred pre-coding matrix. Dynamic rank adaptation is supported on the eNodeB, which signals the applied pre-coding vector to the UE in the Downlink grant.

The UE provides feedback for the MIMO operation (as discussed in section 5.6.9.1) and the eNodeB selects the pre-coding vectors and the number of layers to use accordingly, as illustrated in Figure 5.47. This has some similarity with the MIMO solution in WCDMA, which is based on the closed loop feedback from the UE. In LTE some of the parameters in the downlink assignments are intended for MIMO control, either for informing the device of

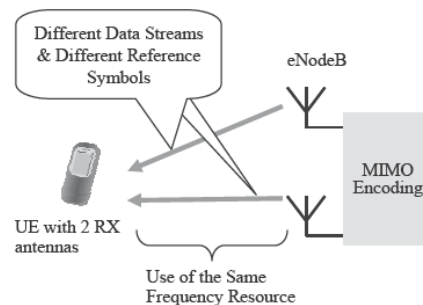

Figure 5.47 Single user MIMO principle

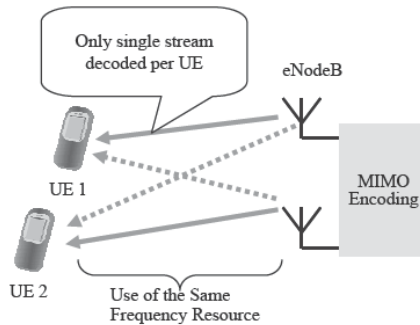

Figure 5.48 Multi-user MIMO transmission principle

the pre-coding applied or whether or not to swap the transport blocks between the code words in the retransmissions.

One specific mode of MIMO operation is the Multi-User MIMO (MU-MIMO) where the eNodeB is sending from two (also four possible from the specifications) antenna ports different data streams intended for different devices. The principle of MU-MIMO is illustrated in Figure 5.48.

5.9.8 Cell Search Procedure

The first action for a LTE device to be performed upon power on is the cell search. In LTE the cell search procedure is based on the use of synchronization signals. Similar to WCDMA, there are primary and secondary synchronization signals (called synchronization channels in the WCDMA specification). The cell search steps are as follows:

- The device will look for the primary synchronization signal at the center frequencies possible at the frequency band in question. There exist three different possibilities for the primary synchronization signal as described in section 5.8.6.
- Once the primary synchronization signal has been detected, the UE will look for the secondary synchronization signal.
- Once one alternative of the 168 possible secondary synchronization signals is detected, the UE has figured out the Physical Cell ID (PCI) value from the address space of 504 IDs.

From the PCI the UE has information about the parameters used for downlink reference signals and thus the UE can decode the PBCH. All this is independent of the actual system bandwidth in question. The LTE network specifications also support automated PCI planning as part of the Self Organization Networks (SON) functionality, as described in section 5.12.

5.9.9 Half Duplex Operation

The LTE specifications also enable half duplex operation, which is basically FDD mode operation (i.e. separate transmission and reception frequency) but transmission and reception do not occur simultaneously, as happens in TDD mode. The intention in 3GPP has been to have an

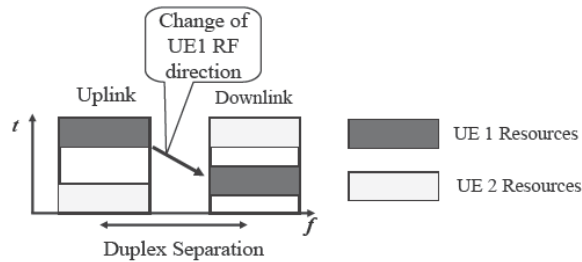

Figure 5.49 LTE FDD half duplex operation

option for the cases where due to the frequency arrangements the resulting requirements for the duplex filter would be unreasonable, resulting in high cost and high power consumption. The duplex operation principle is illustrated in Figure 5.49. It remains to be seen whether the performance requirements for some bands will be specified with the half duplex operation in mind. The eNodeB would obviously need to be aware if some devices are based on half duplex operation. The impact for the data rates would be that uplink and downlink would no longer be independent but the available data rate in one transmission direction would depend on the resources allocated for the other direction. Similar to TDD operation, one would need to schedule the data on a device basis (not on a system basis like in TDD) so that there is no conflict between uplink and downlink allocations for one UE. Also time would be needed for the UE to change between transmit and reception.

5.10 UE Capability Classes and Supported Features

In LTE there are five device capability classes defined. The supported data rates run from 5 to 75 Mbps in the uplink direction and from 10 to 300 Mbps in the downlink direction. All devices support the 20 MHz bandwidth for transmission and reception, assuming that for the given frequency band this has been specified. It is foreseen that for most cases with frequency bands below 1 GHz the interest is with the smallest bandwidths and support for up to 20 MHz will not be specified. For bands above 1 GHz, bandwidths below 5 MHz will often not be needed. Only a category 5 device will do 64QAM in the uplink, others use QPSK and 16QAM. The receiver diversity and MIMO are in all categories, except in category 1, which does not support MIMO. The UE categories are shown in Table 5.5. The step in the data rates up to 300 Mbps

Table 5.5 LTE device categories

	Category 1	Category 2	Category 3	Category 4	Category 5
Peak rate DL/UL	10/5 Mbps	50/25 Mbps	100/50 Mbps	150/50 Mbps	300/75 Mbps
Modulation DL	QPSK/16QAM/64QAM				
Modulation UL	QPSK/16QAM	QPSK/16QAM	QPSK/16QAM	QPSK/16QAM	QPSK/16QAM + 64QAM
MIMO DL	Optional	2 × 2	2 × 2	2 × 2	4 × 4

with category 5 is achieved with the four antenna MIMO transmission, which is not supported by the other categories.

The actual device capabilities are behind other signaling not just these categories. While these categories mainly define the boundaries for the data rates, the test case prioritization in 3GPP also defines what the first phase devices will and will not support. 3GPP uses three different levels for prioritization of the test cases based on the input created by the operators planning to take the system into use. The latest version during writing of this can be found from [19]. The levels are:

- High priority, which refers to the features that are planned to be in the first phase deployments. This is the highest test case category for number of features (as some of the undesired issues were removed from the specifications in the early stages).
- Medium priority, which refers to features planned to be used a few years after initial deployments. Originally this priority level contained features such as large delay CDD, but then it proved difficult (impossible) to deploy later if there were devices not able to reach, for example, PBCH based on this. Similarly the extended cyclic prefix was originally in this class but deploying it later was found to be problematic if there is an existing population of devices unable to support it (due to lack of test cases).
- Low priority, which refers to features where no immediate plans exist for deployments from the 3GPP operator perspective. An example is the UE specific reference symbols for FDD mode operation, which reflects the lack of interest for adaptive antenna arrays in the industry for Release 8 FDD. This is similar to WCDMA where support for dedicated pilots was removed from a later version of the specifications due to lack of practical interest for introducing adaptive antennas. (The WCDMA system contains other means for dealing with adaptive antenna arrays as covered in [5].) In the TDD mode of operation, this feature is a high priority test case to show that many sites using the 1.28 Mcps TDD (TD-SCDMA) in China are based on adaptive antenna arrays. To enable smooth evolution toward LTE, then also LTE devices operating in TDD mode should allow the use of the same antenna structures along with other aspects of LTE TDD mode and TD-SCDMA co-existence as covered in Chapter 12.

5.11 Physical Layer Measurements

5.11.1 eNodeB Measurements

As all the radio functionalities are located in eNodeB, there are few eNodeB measurements that would need to be reported over any interface as there is no separate centralized RRM functionality like the radio network controller in WCDMA. The eNodeB measurements specified in the physical layer specifications in Release 8 in the downlink are as follows [4]:

- the power used (power contribution) for the resource elements that are used to transmit cell-specific reference signals from the eNodeB (in the system bandwidth);
- received interference power per physical resource block;
- thermal noise power over the system bandwidth.

The motivation for these measurements is to enable their consideration in the handover decisions of the relative base station strengths as well as to facilitate inter-cell interference

coordination, as illustrated by part of the X2-interface signaling in Chapter 5. eNodeB may use these internally for different purposes in addition to the other information available for eNodeB.

In 3GPP there are additional indicators as part of the Operation and Maintenance (O&M) specifications to support monitoring the system performance.

5.11.2 UE Measurements and Measurement Procedure

For the UE the following measurements are to be performed inside the LTE system:

- Reference Signal Received Power (RSRP), which for a particular cell is the average of the power measured (and the average between receiver branches) of the resource elements that contain cell-specific reference signals.
- Reference Signal Received Quality (RSRQ) is the ratio of the RSRP and the E-UTRA Carrier Received Signal Strength Indicator (RSSI), for the reference signals.
- E-UTRA RSSI, which is the total received wideband power on a given frequency. Thus it includes the noise ‘from the whole universe’ on the particular frequency, whether that is from interfering cells or any other noise source. E-UTRA RSSI is not reported by the UE as an individual measurement (as indicated in the early versions of [4] until June 2008), but it is only used in calculating the RSRQ value inside the UE.

The scheduling will create sufficient DTX/DRX gaps for the device to perform the measurement. In WCDMA there were specific frames in use with compressed mode when one needed to turn off the transmitter and/or receiver to measure other frequencies, as covered in [5], and most of the measurements were related to the Common Pilot Channel (CPICH).

The following measurements exist for the inter-system:

- UTRA FDD CPICH (CPICH) Received Signal Code Power (RSCP), which represents the power measured on the code channel used to spread the primary pilot channel on WCDMA.
- UTRA FDD (and TDD) carrier RSSI is the corresponding wideband power measurement as also defined for LTE.
- UTRA FDD CPICH E_c/N_0 is the quality measurement, like RSRQ in LTE, and provides the received energy per chip energy over the noise.
- GSM carrier RSSI represents the wideband power level measured on a particular GSM carrier.
- UTRA TDD Primary Common Control Physical Channel (P-CCPCH) RSCP is the code power of the UTRA TDD broadcast channel.
- CDMA2000 $1 \times$ RTT and HRPD Pilot Strengths are the power on the respective pilot channel (code) when considering the handover to cdma2000®.

5.12 Physical Layer Parameter Configuration

The physical layer parameters to configure for connection in a particular cell are the responsibility of the particular eNodeB. Several issues will come from the O&M settings, such as the cyclic prefix lengths to be used. For some parameters, 3GPP has been developing Self Organizing

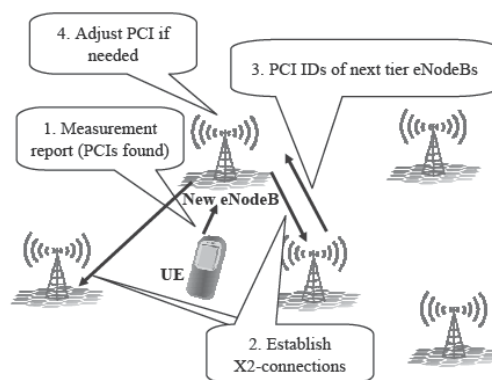

Figure 5.50 Self configuration for PCI

Network (SON) solutions. In the physical layer this covers the Physical Cell ID (PCI), as shown in Figure 5.50. When installing a new cell, the principle is that the cell could select the PCI randomly and once the first measurement report has been obtained from any UE, it learns the PCIs that are in use near by. After that eNodeB knows the neighbors and it can establish the X2 connections (UE then needs to be instructed also to decode the BCH to get the global cell ID after which the O&M system can provide the connection information for X2 creation). Once the X2 connections provide information about the PCI values used in nearby cells, the cell can confirm whether the selected PCI needs to be adjusted or not. Alternatively, the PCI could be obtained directly from O&M, thus avoiding initial conflicts for PCIs between nearby cells.

5.13 Summary

The LTE physical layer has been built on top of OFDMA (for downlink) and SC-FDMA (for uplink) technologies. The resource allocation is dynamic with 1 ms resolution in the time domain and 180 kHz in the frequency domain, making the radio resource utilization well matched to the packet nature of the communication. The physical layer facilitates advanced features known from HSDPA/HSUPA, such as physical layer retransmission, link adaptation, multi-antenna transmission and physical layer eNodeB based scheduling. Additionally there are new properties which take into account the possibilities of new radio access technology, such as frequency domain scheduling, that is facilitated in terms of both physical feedback methods and signaling to make the uplink and downlink resource allocations to the advantage of the frequency domain element. The maximum data rates within the Release 8 UE categories run up to 300 Mbps in downlink and 75 Mbps in the uplink direction. The physical layer design adapts well to the support of different system bandwidths as common channels are not dependent on the actual system bandwidth operated but are always based on the use of resources within the 1.08 MHz block at the center frequency.

References

- [1] 3GPP Technical Specification, TS 36.211, 'Evolved Universal Terrestrial Radio Access (E-UTRA); Physical channels and modulation', 3GPP, v 8.4.0 September 2008.
- [2] 3GPP Technical Specification, TS 36.212, 'Evolved Universal Terrestrial Radio Access (E-UTRA); Multiplexing and channel coding', 3GPP, v 8.4.0, September 2008.
- [3] 3GPP Technical Specification, TS 36.213, 'Evolved Universal Terrestrial Radio Access (E-UTRA); Physical layer procedures', 3GPP, v 8.4.0, September 2008.
- [4] 3GPP Technical Specification, TS 36.214, 'Evolved Universal Terrestrial Radio Access (E-UTRA); Physical layer measurements', 3GPP, v 8.4.0, September 2008.
- [5] H. Holma, A. Toskala 'WCDMA for UMTS', 4th edition, Wiley, 2008.
- [6] 3GPP Technical Report, TR 25.814, 'Physical layer aspect for evolved Universal Terrestrial Radio Access (UTRA)', 3GPP.
- [7] 3GPP Tdoc R1-081126, 'Way forward on RV and NDI signaling', Panasonic et al.
- [8] 3GPP Tdoc R1-070041, 'Dynamic Contention Free Scheduling Request', Motorola.
- [9] 3GPP Tdoc R1-070378, 'Uplink Resource Request for LTE System', Nokia.
- [10] 3GPP Tdoc R1-080931, 'ACK/NACK channelization for PRBs containing both ACK/NACK and CQI', Nokia Siemens Networks, Nokia, Texas Instruments.
- [11] 3GPP Tdoc R1-080035, 'Joint proposal on uplink ACK/NACK channelization', Samsung, Nokia, Nokia Siemens Networks, Panasonic, TI.
- [12] 3GPP Tdoc R1-062840, 'TDM based Multiplexing Schemes between L1/L2 Control and uplink Data', Nokia.
- [13] 3GPP Tdoc R1-072224, 'Uplink control signal transmission in presence of data', Samsung.
- [14] 3GPP Tdoc R1-081852, 'Linkage between PUSCH MCS and amount of control resources on PUSCH', Nokia Siemens Networks, Nokia.
- [15] Chu, D.C., 'Polyphase codes with good periodic correlation properties,' IEEE Transactions Information Theory, vol. 18, pp. 531-532, July 1972.
- [16] Popovic, B.M., 'Generalized chirp-like polyphase sequences with optimum correlation properties,' IEEE Transactions Information Theory, vol. 38, pp. 1406-1490, July 1992.
- [17] 3GPP Tdoc R1-082570, 'Signalling for SRS Hopping Bandwidth', NTT DoCoMo, Panasonic.
- [18] 3GPP Tdoc R1-074977, 'Specification of Formula for Restricted Cyclic Shift Set', LG Electronics, Nokia, Nokia Siemens Networks, Panasonic, Huawei, Texas Instruments.
- [19] 3GPP Tdoc R5-083674, 'LTE Features and Test Prioritisation' NTT DoCoMo.

6

LTE Radio Protocols

Antti Toskala and Woonhee Hwang

6.1 Introduction

The role of the LTE radio interface protocols is to set up, reconfigure and release the Radio Bearer that provides the means for transferring the EPS bearer (as presented in Chapter 3). The LTE radio interface protocol layers above the physical layer include Layer 2 protocols; Medium Access Control (MAC), Radio Link Control (RLC) and Packet Data Convergence Protocol (PDCP). Layer 3 consists of the Radio Resource Control (RRC) protocol, which is part of the control plane. The protocol layer above (for the control plane) is the Non-Access Stratum (NAS) protocol that terminates in the core network side and was addressed in Chapter 3. This chapter describes the general radio interface protocol architecture and then the main functions of the MAC, RLC, PDCP and RRC layers are introduced. The radio protocol aspects of the control plane of the X2 interface – the interface between eNodeBs – is also covered. This chapter concludes with the introduction of the LTE Inter Operability Testing (IOT) bits intended for early UE handling in LTE.

6.2 Protocol Architecture

The overall LTE radio interface protocol architecture is shown in Figure 6.1, covering only the protocol part of the radio access in LTE. Additionally there are protocols in the core network that are between the UE and the core network but these are transparent to the radio layers and are generally referred to as Non-Access Stratum (NAS) signaling.

The physical layer carries the transport channels provided by the MAC layer. The transport channels, listed in Chapter 5, describe how and with what characteristics data are carried on the radio interface on the physical channels. The MAC layer offers the logical channels to the RLC layer. The logical channels characterize the type of data to be transmitted and are covered in detail in section 6.4. Above the RLC layer there is the PDCP layer, now used for both the control and the user plane, in contrast to WCDMA where it was only used for user plane data. Layer 2 provides upwards radio bearers. Signaling Radio Bearers (SRBs) carry the RRC

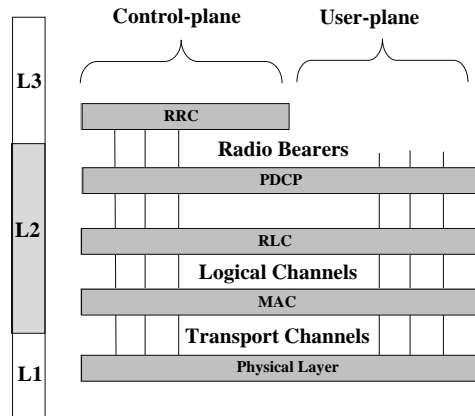

Figure 6.1 LTE Radio Protocol Stacks

signaling messages. Correspondingly the user plane Radio Bearers (RBs) carry the user data. As described in Figure 6.2 on radio protocol architecture for the control plane, MAC, RLC, PDCP and RRC are all located in the eNodeB. With WCDMA RRC and PDCP were both in the RNC, and the MAC layer was either in a NodeB (especially for HSPA) or in a Radio Network Controller (RNC) in case of Release'99 WCDMA.

The control plane signaling between different network elements is carried on the X2 interface for inter-eNodeB communications. For the traffic between the Mobility Management Entity (MME) and eNodeB the S1_MME is used for mobility management related signaling in the control plane. The control plane interfaces inside E-UTRAN and between E-UTRAN and MME are shown in Figure 6.3, as introduced in Chapter 3. All the radio mobility related decisions are still carried out in eNodeB but the MME acts as the mobility anchor when the UE moves between different eNodeBs. The X2 protocol stack itself is not shown, but rather the architectural aspects. The full protocol stack for X2, including the underlying transport layers, is described in Chapter 3, while later in this chapter more details are discussed for radio related signaling

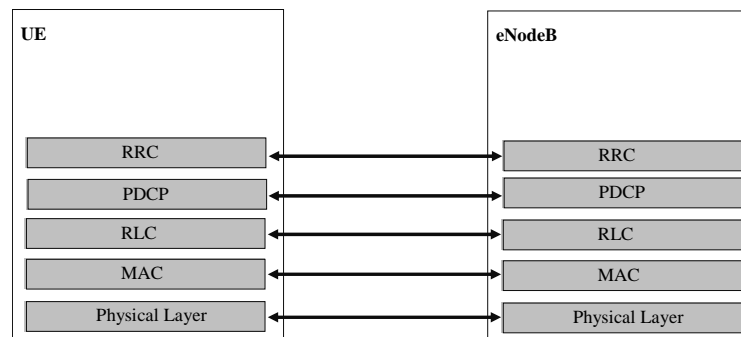

Figure 6.2 LTE control plane radio protocols in LTE architecture

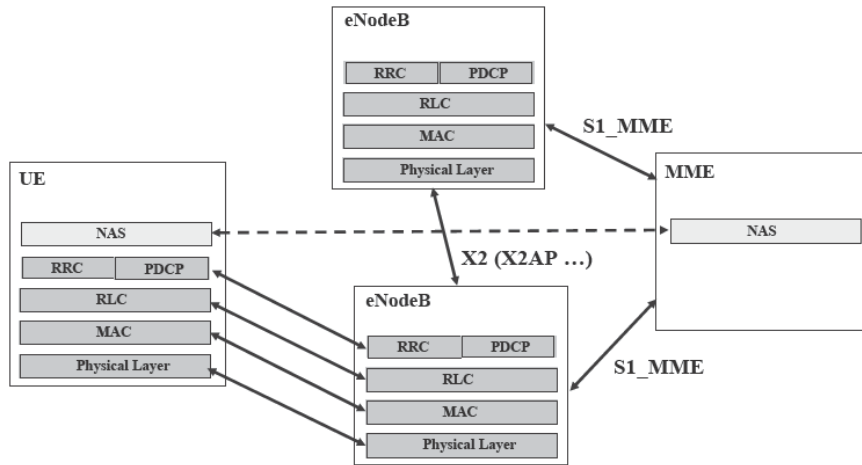

Figure 6.3 LTE control plane radio protocols in LTE architecture

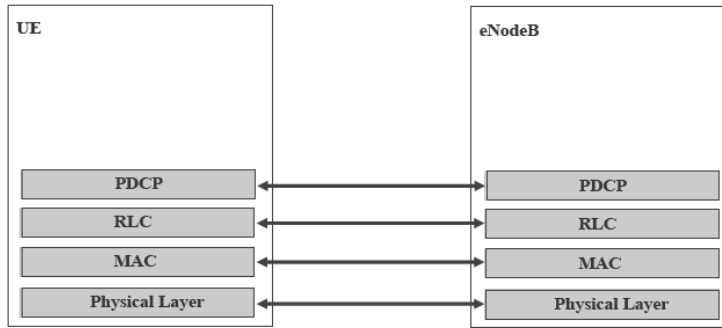

Figure 6.4 LTE user plane radio protocols in LTE architecture

in the X2 Application Protocol (X2AP). Note also that most of the RRC signaling traffic goes through the PDCP layer, thus PDCP is part of the control plane as well.

For the user plane, similarly all the network side user plane radio protocols are located in the eNodeB as shown in Figure 6.4. This was enabled from the system design point of view also because the radio technology chosen does not need macro-diversity, thus flat architecture was easily facilitated without the need for providing the user data continuously over the X2 interface.

6.3 Medium Access Control

The MAC layer maps the logical channels to transport channels, as shown in Figure 6.5. The other tasks of the MAC layer in LTE are:

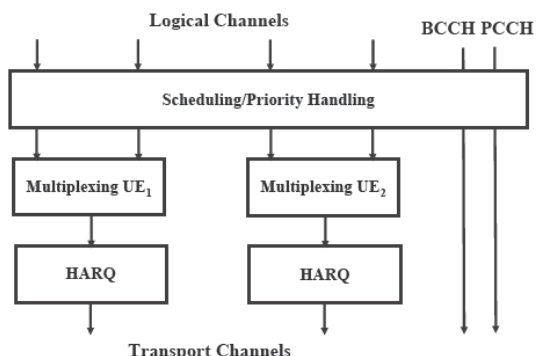

Figure 6.5 MAC layer (downlink)

- MAC layer multiplexing/demultiplexing of RLC Payload Data Units (PDUs) belonging to one or different radio bearers into/from Transport Blocks (TB) delivered to/from the physical layer on transport channels; also the Padding if a PDU is not fully filled with data.
- Traffic volume measurement reporting, to provide RRC layer information about the traffic volume experienced.
- Error correction through HARQ, to control the uplink and downlink physical layer retransmission handling in the eNodeB together with the scheduling functionality.
- Priority handling between logical channels of one UE and between UEs by means of dynamic scheduling, thus the scheduling in the eNodeB is considered as MAC layer functionality similar to HSPA.
- Transport format selection (as part of the link adaptation functionality in the eNodeB scheduler).

Compared to WCDMA there is no ciphering functionality in the MAC layer, neither is there transport channel type switching as the user data are only transmitted over a single type of transport channel (Uplink Shared Channel [UL-SCH] or Downlink Shared Channel [DL-SCH]). As the user identification is based on the physical layer signaling, there is no need to use the MAC layer for UE identification. The downlink MAC layer functionality in Figure 6.5 is otherwise identical in the uplink direction, but obviously the Broadcast Control Channel (BCCH) and Paging Control Channel (PCCH) are not present there and only one user is considered in the UE uplink MAC structure. The MAC layer details in 3GPP are covered in [1]. The MAC layer specification also covers the random access procedure description, including the power ramping parameterization as covered in connection with the physical layer description in Chapter 5.

6.3.1 Logical Channels

The MAC layer provides the service to the RLC layer by logical channels. Different logical channels are defined for different data transfer services in the uplink and downlink directions.

The uplink logical channels mapping to transport channels are shown in Figure 6.6. The following logical channels are defined in LTE uplink:

- Common Control Channel (CCCH) transfers control information between the UE and the network; used when no RRC connection exists between the UE and the network.
- Dedicated Control Channel (DCCH) is a point-to-point channel for dedicated control information between the UE and the network.
- Dedicated Traffic Channel (DTCH) carries all the user data for point-to-point connection.

In the uplink direction all the logical channels are mapped to the UL-SCH, there is no logical channel mapped on the Random Access Channel (RACH) as it is not carrying any information above the MAC layer.

The following logical channels are defined in the LTE downlink, with the mapping to the downlink transport channels as illustrated in Figure 6.7:

- CCCH, DCCH and DTCH have the same functionality as their uplink counterparts, now just delivering the control or user data information in the downlink direction. They are mapped to the DL-SCH in the transport channels.
- Multicast Control Channel and Multicast Traffic Channel are not included in the Release 8 version of the specifications but are expected to be part of Release 9 LTE (or a later release) version, due at the end of 2009. Their intention is to carry multicast data (and related control information) in a point-to-multipoint fashion, similar to the Multimedia Broadcast Multicast Service (MBMS) part of WCDMA in Release 6.
- BCCH carries the broadcast information, such as the parameters necessary for system access. It uses the Broadcast Channel (BCH) as the transport channel for the Master Information Block (MIB) while the actual System Information Blocks (SIBs) are mapped on DL-SCH.
- Paging Control Channel (PCCH) carries the paging information, to enable the network to page a device not in connected mode and is mapped to the Paging Channel (PCH).

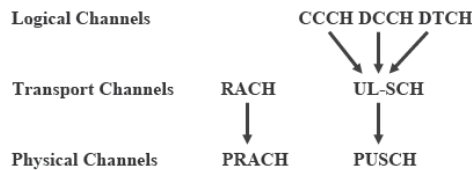

Figure 6.6 PDCP layer operation

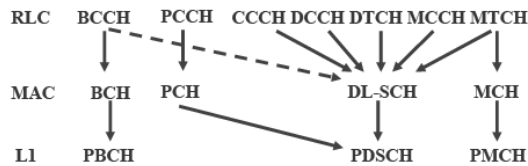

Figure 6.7 Mapping of the downlink logical and transport channels

6.3.2 Data Flow in MAC Layer

The MAC layer receives data from the RLC layer, as MAC Service Data Units (SDUs). The MAC PDU then consists of the MAC header, MAC SDUs and MAC control elements. The MAC control elements carry important control information that is used for several control functionalities, as shown in Figure 6.8. In the uplink direction (in connection with UL-SCH), in addition to data (in MAC SDU) the MAC payload can also contain several control information elements, such as:

- buffer status report, to tell how many data there are in the UE waiting for transmission and information about the priority of the data in the buffer;
- power headroom report to indicate the available uplink transmission power resources;
- contention resolution procedure information (CCCH and C-RNTI).

In the downlink direction (in connection with DL-SCH), the following control information can be carried in the MAC control elements:

- control of the Discontinuous Reception (DRX) operation (when to start, when to stop, etc.);
- timing advance commands to adjust uplink timing;
- contention resolution information.

The MAC header and payload for RACH are different, as is the key to enable the access procedure to be completed and deal with potential collisions or overload situations in the cell

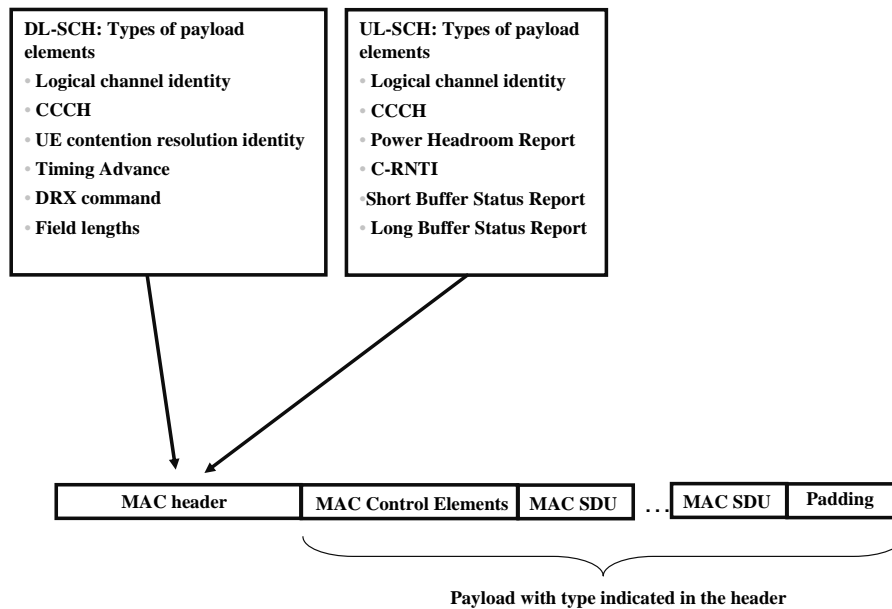

Figure 6.8 MAC PDU structure and payload types for DL-SCH and UL-SCH

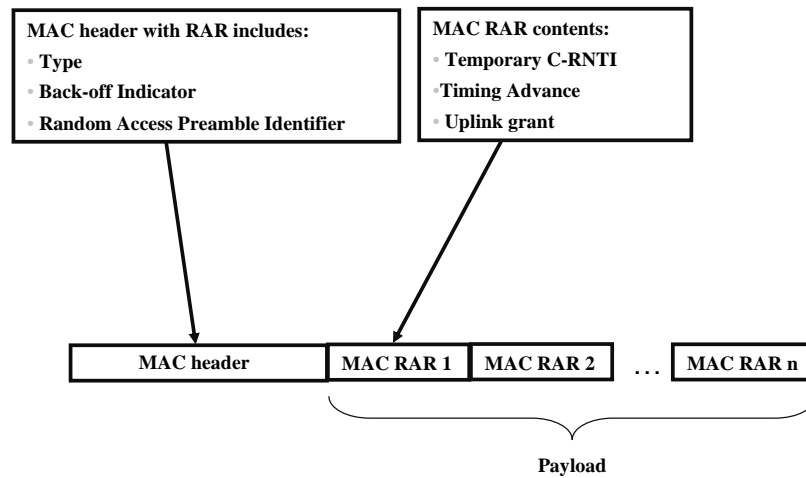

Figure 6.9 MAC PDU structure with random access response

that might have occurred. The MAC layer random access signaling is indicated in Figure 6.9, and it consists of the necessary control information needed to enable data transmission after a successful RACH procedure (detection of preamble after the ramping as covered in Chapter 5). The information transmitted in the MAC Random Access Response (RAR) covers:

- timing advance indicating the necessary adjustment needed for the uplink transmission to ensure different users fit without overlap or extra guard periods for the 1 ms resource allocations;
- uplink grant indicates the detailed resources (time and frequency domain) to be used in the uplink direction;
- temporary C-RNTI provides the UE with a temporary identity to be used in completing the random access operation;
- the header indicates possible back-off and the identification of the preamble received, which the UE had chosen (randomly) in connection with the physical layer random access procedure as described in Chapter 5.

6.4 Radio Link Control Layer

The RLC layer has the following basic functionalities:

- transferring the PDUs received from higher layers, i.e. from RRC (Common Control Channel) or PDCP (other cases, including user plane);
- then (depending on the RLC mode used), error correction with ARQ, concatenation/segmentation, in-sequence delivery and duplicate detection may be applied;
- protocol error handling to detect and recover from the protocol error states caused by, for example, signaling errors.

Fundamentally the key difference of the LTE RLC specifications [2] when compared to WCDMA is the lack of ciphering functionality in RLC. Also the re-segmentation before RLC retransmission is enabled. Thus compared to the order of sequences in [3], the buffer is before segmentation/concatenation functionality.

6.4.1 RLC Modes of Operation

The RLC can be operated in three different modes:

- **Transparent Mode (TM).** In the TM mode the RLC only delivers and receives the PDUs on a logical channel but does not add any headers to it and thus no track of received PDUs is kept between the receiving and transmitting entity. The TM mode of operation is only suited for services that do not use physical layer retransmissions or that are not sensitive to delivery order. Thus from the logical channel only BCCH, CCCH and PCCH can be operated in TM mode. In WCDMA the AMR speech call (also CS video) was used in transparent mode as well because there were no retransmissions, but now because all the user data have physical layer retransmissions and as the minimum in-sequence delivery is expected, other modes are used instead.
- **Unacknowledged Mode (UM)** of operation does provide more functionality, including in-sequence delivery of data which might be received out of sequence due to HARQ operation in lower layers. The UM Data (UMD) are segmented or concatenated to suitable size RLC SDUs and the UMD header is then added. The RLC UM header includes the sequence number for facilitating in-sequence delivery (as well as duplicate detection). As shown in Figure 6.10, the receiving side will then be based on the header information due to the re-ordering and then the necessary reassembly in response to the segmentation or concatenation is applied. In addition to the DCCH and DTCH, the UM RLC has been planned for use with multicast channels (MCCH/MTCH) expected to be completed beyond Release 8.
- **Acknowledged Mode (AM)** of RLC operation provides, in addition to the UM mode functionalities, also retransmission if PDUs are lost as a result of operations in the lower layers.

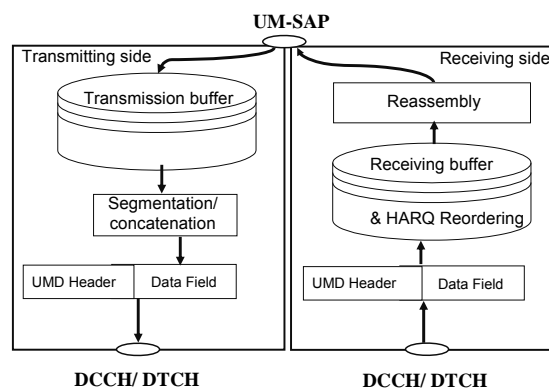

Figure 6.10 RLC UM operation

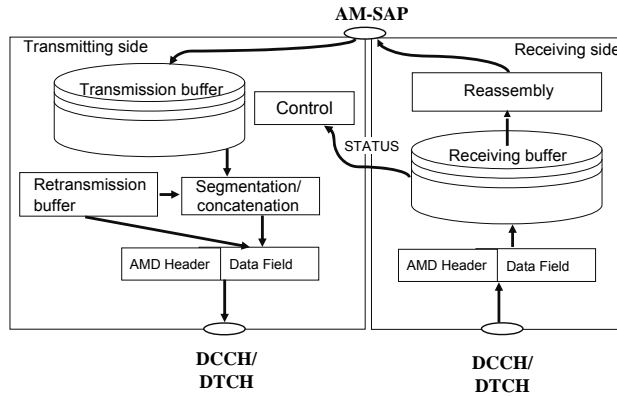

Figure 6.11 RLC AM mode operation

The AM Data (AMD) can also be re-segmented to fit the physical layer resources available for retransmissions, as indicated in Figure 6.11. The Header now contains information on the last correctly received packet on the receiving side along with the sequence numbers, as for the UM operation.

6.4.2 Data Flow in RLC Layer

For the AM RLC operation, the RLC layer receives the data from the PDCP layer, the data are stored in the transmission buffer and then, based on the resources available, segmentation or concatenation is used. In the downlink direction (DTCH/DCCH) the following control means are available for AM RLC purposes, either in the AMD PDU or in the status PDU:

- 10 bit Sequence Number (SN), to enable a long enough in-sequence delivery window;
- last correctly received SN and incorrectly received SN(s) (detected to be lost).

When the receiving entity gets a RLC PDU, it checks for possible duplicated parts and will then forward it further for re-assembly (assuming no SNs are missing in between) and provides data to the next protocol layer (in this case for PDCP) for further processing. If there was a SN missing, the receiving entity will request a retransmission from the transmitting side.

6.5 Packet Data Convergence Protocol

The Packet Data Convergence Protocol (PDCP) is located above the RLC layer of the user plane and PDCP is also used for most of the RRC messages. The key difference to WCDMA is that now all user data go via the PDCP layer, because ciphering is now in the PDCP, which is located in the eNodeB. In some early plans of the LTE architecture PDCP was on the other side of the S1 interface (on the core network) but was later placed in eNodeB along with all other radio protocols. The key functionalities of the PDCP are:

- Header compression and corresponding decompression of the IP packets. This is based on the Robust Header Compression (ROHC) protocol, specified in the Internet Engineering Task Force (IETF) [4–9] and also part of the WCDMA PDCP layer. Header compression is more important for smaller IP packets in question, especially in connection with the VoIP service, as the large IP header could be a significant source of overhead for small data rates.
- Ciphering and deciphering both the user plane and most of the control plane data, a functionality that in WCDMA was located in the MAC and RLC layers.
- Integrity protection and verification, to ensure that control information is coming from the correct source.

The PDCP layer receives PDCP SDUs from the NAS and RRC and after ciphering and other actions, as shown in Figure 6.12 for operation of packets that are associated to a PDCP SDU, the data are forwarded to the RLC layer. Correspondingly, in the receiving side the data are received from the RLC layer. Besides the functionalities listed above, the PDCP layer has specific functions in connection with the handover events (intra-LTE). The PDCP does the in-order delivery function in the downlink direction and detects duplicates. In the uplink direction, PDCP retransmits all the packets which have not been indicated by lower layers to be completed, as the lower layers will flush all the HARQ buffers with handover. In the downlink direction, the PDCP layer will forward the non-delivered packets to the new eNodeB as described in the Chapter 7. This is to ensure that no data are lost in connection with a handover event between LTE eNodeBs. The LTE PDCP specification in 3GPP is covered in [10].

6.6 Radio Resource Control (RRC)

Radio Resource Control messages are a major part of the control information exchanged between the UE and E-UTRAN. The RRC in E-UTRAN has been simplified significantly compared to that in UTRAN by reducing the number of messages and the redundancies in the messages. RRC uses the same protocol language as WCDMA – Abstract Syntax Notation One (ASN.1)

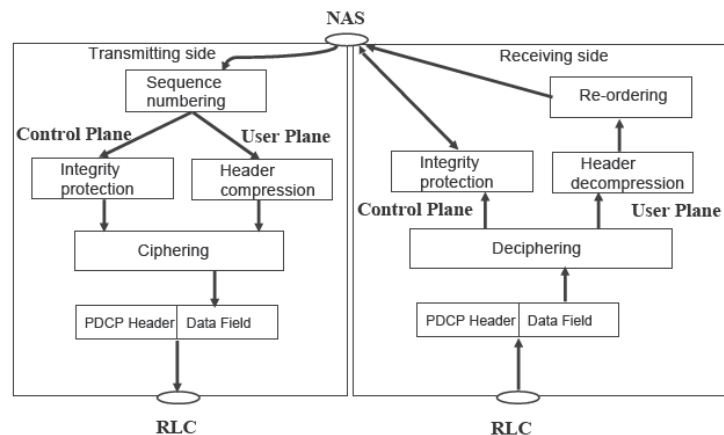

Figure 6.12 PDCP layer operation for the packets which are associated to a PDCP SDU

– as it has been efficient in facilitating the evolution between different release versions with an extension capability within ASN.1. The encoding on the X2 and S1 interface messages also uses ASN.1. The LTE RRC specification in [11] has the ASN.1 message descriptions at the end.

6.6.1 UE States and State Transitions Including Inter-RAT

Contrary to the UTRAN (WCDMA), UE states in E-UTRAN are also simplified significantly and there are only two states, i.e., RRC_CONNECTED and RRC_IDLE, depending on whether the RRC connection has been established or not.

In the RRC_IDLE state, the UE monitors a paging channel to detect incoming calls, acquires system information and performs neighboring cell measurement and cell (re)selection. In this state, a UE specific DRX may be configured by the upper layer and the mobility is controlled by the UE.

In the RRC_CONNECTED state, the UE transfers/receives data to/from the network. For this, the UE monitors control channels that are associated with the shared data channel to determine if data are scheduled for it and provides channel quality and feedback information to eNodeB. Also in this state, the UE performs neighboring cell measurement and measurement reporting based on the configuration provided by eNodeB. In contrast with the UTRAN system, the UE can acquire system information from BCCH during the RRC_CONNECTED state. At lower layers the UE may be configured with a UE specific DRX and the mobility is controlled by the network, i.e. handover.

6.6.1.1 E-UTRAN States and Inter-RAT State Mobility

Figure 6.13 shows the mobility support between E-UTRAN, UTRAN and GSM EDGE Radio Access Network (GERAN). As CELL_FACH in UTRAN is considered a very short period, a direct transition from UTRAN CELL_FACH to E-UTRAN RRC state is not supported.

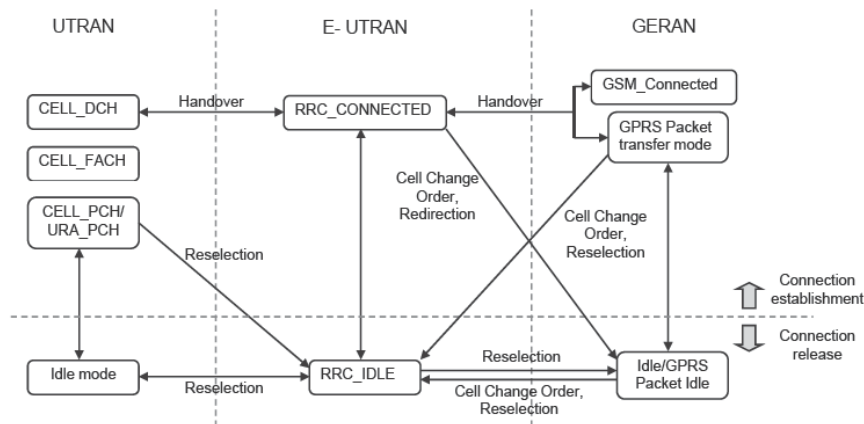

Figure 6.13 E-UTRAN RRC States and State transitions among 3GPP systems

6.6.1.2 Signaling Radio Bearers (SRB)

SRBs are special radio bearers which convey only RRC messages and NAS messages. There are three SRBs defined. SRB0 is used for RRC messages using CCCH, like during RRC connection set-up or during radio link failure. Thus, for instance, the following messages are transferred via SRB0: RRC Connection Request message, RRC Connection Setup message, RRC Connection Reject message, RRC Connection Reestablishment Request message, RRC Connection Reestablishment message, RRC Connection Reestablishment Reject message. Once a RRC connection is established, SRB1 is used to transfer both RRC messages using DCCH and NAS messages until the security is activated. Once the security is successfully activated, SRB2 is set up and NAS messages are transferred via SRB2 while RRC messages are still transferred via SRB1. SRB2 has a lower priority than SRB1.

6.6.2 RRC Functions and Signaling Procedures

The following functions are provided by RRC protocol layer:

- broadcast of system information
- paging
- establishment, maintenance and release of an RRC connection between the UE and e-UTRAN
- security functions including key management
- establishment, configuration, maintenance and release of point-to-point Radio Bearers
- UE measurement reporting and control of the reporting
- handover
- UE cell selection and reselection and control of cell selection and reselection
- context transfer between eNodeBs
- NAS direct message transfer between network and UE
- UE capability transfer
- generic protocol error handling
- support of self-configuration and self-optimization.

6.6.2.1 Broadcast of System Information

System information contains both non-access stratum (NAS) and access stratum (AS) related information. Based on the characteristics and usages of the information, the system information elements are grouped together into Master Information Block (MIB) and different System Information Blocks (SIBs).

As MIB is the most important information block, MIB is transferred on the BCH every 40ms and is repeated within 40ms. The first transmission of the MIB is scheduled at SFN mod 4=0 in the subframe #0. UE will acquire MIB to decode SCH. The MIB contains a DL system bandwidth, PHICH configuration and a system frame number (SFN).

SIB1 is scheduled in a fixed manner with a periodicity of 80ms and is repeated within 80ms. The first transmission of the SIB1 is scheduled at SFN mod 8=0 in the subframe #5. SIB 1 contains cell access related information (e.g. a PLMN identity list, tracking area code, cell identity, etc.), information for cell selection (e.g. minimum required Rx level in the cell

and offset), p-Max, a frequency band indicator, scheduling information, TDD configuration, SI-window length and system information value tag.

All other SIBs except SIB1 are contained in SI message(s). Each SI message is transmitted periodically in time domain windows (i.e. SI-Window) and SI-Windows for different SI messages do not overlap. The length of a SI-window is defined in SIB1 and is common for all SI messages.

Figure 6.14 shows how the UE can find each SI message to read the SIBs in it.

SIB2 is not listed in the scheduling information in SIB1 but the first SI message contains SIB2 as the first entry.

SIB2 contains radio resource configuration information which is common to all UEs. More specifically, SIB2 includes access barring information, radio resource configuration of common channels (RACH configuration, BCCH configuration, PCCH configuration, PRACH configuration, PDSCH configuration, PUSCH configuration and PUCCH configuration, sounding reference signal configuration, uplink power control information), timers and constants which are used by UEs, MBSFN subframe configuration, time alignment timer and frequency information (UL EARFCN, uplink bandwidth and additional spectrum emission).

SIB3 contains cell-reselection information that is common for intra-frequency, inter-frequency and/or inter-RAT cell re-selection. Speed dependent scaling parameters are also included in SIB3 to provide a different set of re-selection parameters depending on UE speed.

SIB4 contains neighbor cell related information only for intra-frequency cell re-selection. Thus in addition to intra-frequency neighboring cell list with Q_{offset} , an intra-frequency black-listed cell list is also included in SIB4.

SIB5 contains information relevant only for inter-frequency cell re-selection like E-UTRAN inter-frequency neighboring cell related information and E-UTRAN inter-frequency blacklisted cell list.

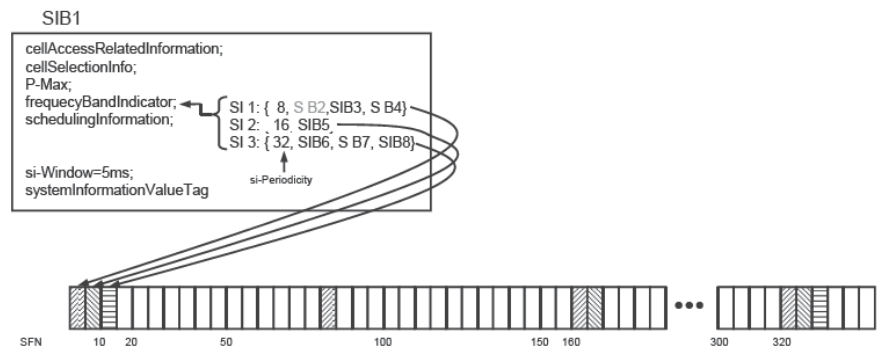

determine integer value $x = (n - 1) * w$, where n is the order of entry in the list of SI message and w is the *si-WindowLength*

si-Window starts at subframe # a , where $a = x \text{ mod } 10$, in the next radio frame for which $\text{SFN mod } T = \text{FLOOR}(x/10)$ where T is the *si-Periodicity* of the concerned SI message

Figure 6.14 Acquisition of SI message

SIB6 contains information relevant only for cell re-selection to the UTRAN. Thus UTRA FDD and TDD frequency information is included in SIB6.

SIB7 contains information relevant only for cell re-selection to the GERAN such as GERAN neighboring frequency list.

SIB8 contains information relevant only for cell re-selection to the cdma2000® system. Thus SIB8 contains cdma2000® system time information, HRPD related parameters and 1xRTT related parameters.

SIB9 contains a home eNodeB identifier, which is a maximum of 48 octets so that the UE can display the home eNodeB identifier to help manual home eNodeB selection.

SIB10 contains Earthquake and Tsunami Warning System (ETWS) primary notification and SIB11 contains ETWS secondary notification.

In case the system information is modified, the SI messages may be repeated during the *modification period*. The *modification period* starts at $SFN \bmod \text{modification period} = 0$. During the first modification period, system information modification indicator is sent to the UE by paging message and in the next modification period, the network transmits the updated system information.

The *modification period* is calculated as follows:

modification period (in number of radio frames) = $\text{modificationPeriodCoeff} * \text{defaultPagingCycle} \text{ DIV } 10\text{ms}$

where $\text{modificationPeriodCoeff}$ is: signaled in BCCH-Configuration in SIB2, value = 1, 2, 4, 8 and $\text{defaultPagingCycle}$ is: 320 ms, 640 ms, 1280 ms, 2560 ms (signaled in PCCH-configuration in SIB2).

The value tag in SIB1 is to indicate a change in SI messages. The SI message is considered to be valid for a maximum of 3 h from the moment it was acquired.

6.6.2.2 Paging

The main purpose of a paging message is to page UEs in RRC_IDLE mode for a mobile terminated call. Also the paging message can be used to inform UEs, in RRC_IDLE as well as in RRC_CONNECTED modes, that system information will be changed or that the ETWS notification is posted in SIB10 or SIB11.

As UE may use DRX in idle mode to reduce power consumption, UE should be able to calculate when to wake up and to check the correct subframe. For this, the UE stores the default paging cycle and the number for the paging group when it receives the necessary information from the SIB2 and applies it to the calculation as described in section 7 in TS36.304.

UE can be paged by either S-TMSI (temporary UE ID allocated by MME) or IMSI. In Release 8, IMEI paging is not considered.

For the CS fallback, if UE had registered to a CS core network and received a temporary ID from the CS core network, CS paging can be delivered to UE with a corresponding core network indicator (i.e. CS or PS). In this case, the UE should deduce the correct CS UE identity based on the PS UE identity included in the paging message and include the CS UE identity in the paging response once it is moved to another RAT. The details for the CS fallback procedure can be found in section 6.6.2.8.

6.6.2.3 UE Cell Selection and Reselection and Control of Cell Selection and Reselection

Based on idle mode measurements and cell selection parameters provided in SIBs, the UE selects the suitable cell and camps on it. In the LTE system, the priority parameter has been newly introduced. eNodeB can provide a priority per LTE frequency and per RAT in SIBs or RRC connection Release message. In case the UE is camping on a cell on the highest priority frequency, the UE doesn't need to measure cells in other frequencies or RAT as long as the signaling strength of the serving cell is above a certain level. On the other hand, if the UE is camped on a cell in the low priority layer, it should measure other cells under higher priority frequencies or RAT regularly.

This priority concept is also adapted to Release 8 UTRAN and GERAN (or GSM) system for inter-RAT cell reselection.

The LTE idle mode mobility is explained in Chapter 7 in more detail.

6.6.2.4 Establishment, Maintenance and Release of an RRC Connection Between the UE and E-UTRAN

The RRC Connection Setup procedure, as shown in Figure 6.15, is triggered by a request from the UE NAS layer for various reasons such as a mobile originated call, NAS signaling transfer or a paging response. Consequently the RRC connection is established between UE and eNodeB and SRB1 is set up. If the network is overloaded, eNodeB can set access class barring parameters in SIB2 appropriately and/or reject the RRC Connection Request with a wait timer.

If the UE has a valid S-TMSI, the UE includes it in the RRC connection request message. Otherwise the UE includes a 40 bit random value. Due to the limited size of the message, only five establishment causes are defined in the RRC Connection Request message, i.e. emergency, high priority access, mobility terminated access, mobile originated signaling and

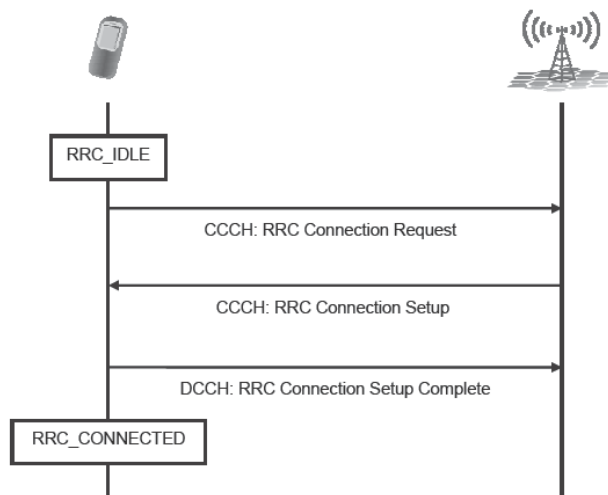

Figure 6.15 RRC Connection Setup procedure

mobile originated data. An NAS service request message is conveyed in the RRC Connection Setup Complete message.

SIB1 broadcasts at most 6 PLMN identities (which can also facilitate network sharing) and the UE selects one and reports it in the RRC Connection Setup Complete message. When the UE is registered to an MME, the UE also includes the identity of the registered MME in the RRC Connection Setup Complete message. Then eNodeB finds/selects the correct MME (which stores the UE idle mode context) in case that S1-flex is deployed and starts S1 connection setup.

After a successful RRC Connection setup procedure, the UE moves to the RRC_CONNECTED state.

6.6.2.5 Security Functions Including Key Management

The security keys for the Access Stratum (AS), covering user data and RRC control signaling, are different from those used on the Evolved Packet Core (EPC) side. From the eNodeB perspective the following keys are necessary (ignoring the keys used for NAS signaling):

- K_{eNB} is derived by UE and MME from the 'master key' (K_{ASME}) and then provided by MME to eNodeB. K_{eNB} is used to derive the necessary keys for AS traffic and also for the derivation of K_{eNB}^* during handover.
- K_{eNB}^* is derived by UE and source eNodeB from either K_{eNB} or from a valid Next Hop (NH) in case Next Hop is available. At handover, UE and target eNodeB will derive a new K_{eNB} for AS traffic from K_{eNB}^* .
- K_{UPenc} is used for the user plane traffic ciphering with the key and is derived from K_{eNB} .
- K_{RRCint} is derived from K_{eNB} to be used for RRC message integrity handling.
- K_{RRCenc} is derived from K_{eNB} to be used for RRC message ciphering.
- Next Hop (NH) is an intermediate key that is used for deriving K_{eNB}^* for the provision of security for intra-LTE handover purposes. There is a related counter, Next Hop Chaining Counter (NCC), which determines whether the next K_{eNB}^* needs to be based on the current K_{eNB} or if a fresh NH is needed. If no fresh NH is available, the K_{eNB}^* is derived by UE and the source eNodeB from the target PCI and K_{eNB} (horizontal key derivation) or if a fresh NH is available, then derivation is based on the target PCI and a new NH is provided (vertical key derivation).

The EPC and UE will share the same master key after the security procedure is completed. This master key (K_{ASME}) is not provided outside the EPC but keys derived from it and necessary for the traffic between eNodeB and UE are delivered to the eNodeB. The eNodeB retains a given key as long as the UE is connected to it but will delete the keys when the UE is moving to idle mode (or to another eNodeB). The integrity and ciphering algorithm can be changed only upon handover. The AS keys are changed upon every handover and connection re-establishment. In the LTE system, a handover can be performed only after security is activated.

RRC integrity and ciphering are always activated together and never de-activated, but it is possible to use a NULL ciphering algorithm. In addition to the keys, security algorithms also use a sequence number as inputs, which consists of a PDCP Sequence Number and a Hyper Frame Number (HFN).

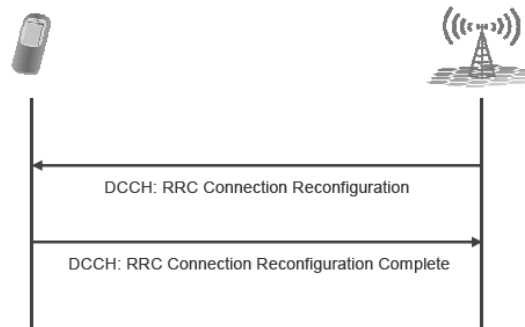

Figure 6.16 RRC Connection Reconfiguration procedure

6.6.2.6 Establishment, Maintenance and Release of Point-to-point Radio Bearers

A RRC connection reconfiguration procedure, as shown in Figure 6.16, is used to maintain and modify radio bearers and to release data radio bearers, i.e. SRBs cannot be released by the RRC connection reconfiguration procedure.

The parameters defined in the radio resource configuration information element group in the RRC Connection Reconfiguration message mainly deal with the configuration of the radio bearer. When the RRC Connection Reconfiguration message is used to set up a new Data Radio Bearer (DRB), a corresponding NAS message is also included within this message.

6.6.2.7 UE Measurement Reporting and Control of the Reporting

A measurement configuration parameter in the RRC Connection reconfiguration message is used to configure measurements in UEs (for measurements inside LTE or for measurements from other Radio Access Technologies [RATs]) and a measurement report message is used for reporting.

The measurement configuration consists of the following parameters.

- 1 Measurement objects: The objects on which the UE shall perform the measurements. E-UTRAN configures only a single measurement object for a given frequency.
 - (a) For intra-frequency (i.e. measurements at the same downlink carrier frequency as the serving cell) and inter-frequency measurement (i.e. measurements at frequencies which differ from the downlink carrier frequency of the serving cell), a measurement object is a single E-UTRA carrier frequency. For this carrier frequency, E-UTRAN can configure a list of cell specific offsets and a list of blacklisted cells.
 - (b) For inter-RAT UTRA measurements, a measurement object is a set of cells on a single UTRA carrier frequency.
 - (c) For inter-RAT GERAN measurements, a measurement object is a set of GERAN carrier frequencies.
 - (d) For inter-RAT cdma2000® measurements, a measurement object is a set of cells on a single cdma2000® carrier frequency.

- 2 Reporting configuration: The reporting configuration contains the reporting criteria and reporting format. The reporting criteria are for the UE to trigger a measurement report and can be either event triggered or periodic. Periodic reporting is especially used for measuring an automatic neighbor cell search. Reporting format includes the quantities which should be included in the measurement report (e.g. the number of cells to report).
 - (a) Reporting criteria: For an event triggered report, the criteria for E-UTRA measurements are A1, A2, A3, A4 and A5. For inter-RAT measurement, B1 and B2 are used.
 - (b) Event A1: Serving becomes better than absolute threshold.
 - (c) Event A2: Serving becomes worse than absolute threshold.
 - (d) Event A3: Neighbor becomes amount of offset better than serving.
 - (e) Event A4: Neighbor becomes better than absolute threshold.
 - (f) Event A5: Serving becomes worse than absolute threshold 1 and Neighbor becomes better than another absolute threshold 2.
 - (g) Event B1: Neighbor becomes better than absolute threshold.
 - (h) Event B2: Serving becomes worse than absolute threshold 1 and Neighbor becomes better than another absolute threshold 2.
- 3 Measurement identities: Measurement identity binds one measurement object with one reporting configuration. The measurement identity is used as a reference number in the measurement report.
- 4 Quantity configurations: One quantity configuration can be configured per RAT (i.e. E-UTRA, UTRAN, GERAN and cdma2000® each) and contains the filter coefficient for the corresponding measurement type.
- 5 Measurement gaps: Periods that the UE may use to perform measurement. Measurement gaps are used for inter-frequency and inter-RAT measurements.

6.6.2.8 Handover

Usually eNodeB triggers handover based on the measurement result received from the UE. A handover can be performed inside E-UTRAN or to E-UTRAN from other RAT or from E-UTRAN to another RAT and is classified as intra-frequency intra-LTE handover, inter-frequency intra-LTE handover, inter-RAT towards LTE, inter-RAT towards UTRAN handover, inter-RAT towards GERAN handover, and inter-RAT towards cdma2000® system handover.

Intra-LTE handover

For intra-LTE handover, the source and target are both in the LTE system, and the RRC connection reconfiguration message with the mobility control information (including the parameters necessary for handover) is used as a handover command. When an X2 interface exists between the source eNodeB and the target eNodeB, the source eNodeB sends X2: Handover Request message to target eNodeB to prepare the target cell. Target eNodeB builds RRC connection reconfiguration message and transfers to source eNodeB in the X2: Handover Request Acknowledge message, as shown in Figure 6.17.

Inter-radio access technology handover to other radio access technology

Based on UE measurement reporting, the source eNodeB can decide the target RAT and in Release 8 the target RAT can be UTRAN, GERAN or cdma2000® system. To perform the inter-RAT handover to another RAT, the actual handover command message is built by the target RAT and is sent

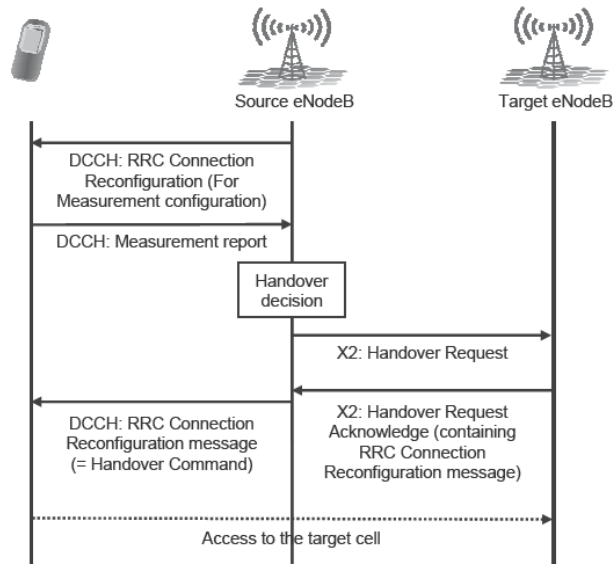

Figure 6.17 Inter-eNodeB Handover procedure

to the source eNodeB transparently. The source eNodeB includes this actual handover command in the Mobility From E-UTRA Command message as a bit string and sends it to the UE.

As the LTE system supports packet service only, if a multi-mode UE wants to start a CS service, CS fallback can be performed. A handover procedure is mainly used for CS fallback to the UTRAN system. Either a handover procedure or a cell change order procedure is used for CS fallback to the GERAN system. A RRC Connection release procedure is used for CS fallback to cdma2000® system. To align the behavior of cell change order with inter-RAT handover, the cell change order procedure uses the Mobility From EUTRA Command message. Also in case, no VoIP service is supported in the target RAT and if the network nodes support, SR-VCC (Single Radio Voice Call Continuity) handover can be performed.

Inter-radio access technology handover from other radio access technology

The handover is triggered based on the criteria defined in the source RAT system. When the target eNodeB receives a S1: Handover Request message from MME, it allocates the necessary resources, builds the RRC Connection Reconfiguration message (=Handover Command) and sends it in the S1: Handover Request Acknowledge message to MME. Thus this RRC Connection Reconfiguration message will be transferred to the UE via source RAT.

CS fallback

As initial LTE deployment may not support voice services as such, 3GPP agreed to provide a means to fallback a CS voice service to the GERAN or UTRAN system. For CS fallback, PS handover, Cell change order and RRC connection release can be used and eNodeB decides the actual method. In Release 8, 3GPP decided that for CS fallback to UTRAN system, only PS handover, and for CS fallback to GERAN system, PS handover and cell change order with the

network assistance (NACC) (i.e. providing some system information about the target cell to speed up the cell selection procedure) should be considered. The two methods are illustrated in Figure 6.18 and Figure 6.19.

For an incoming CS call, the UE is registered to the CS core network in addition to MME. In case the UE receives CS paging or wants to initiate a mobile originated CS call, the UE indicates

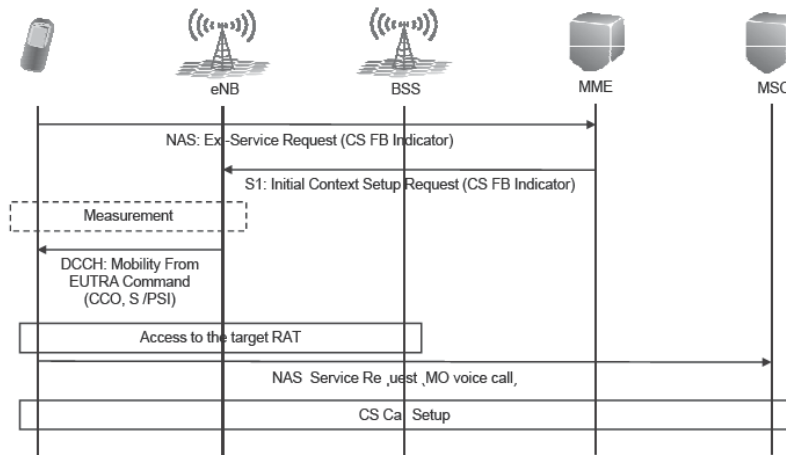

Figure 6.18 CS fallback with Cell Change Order

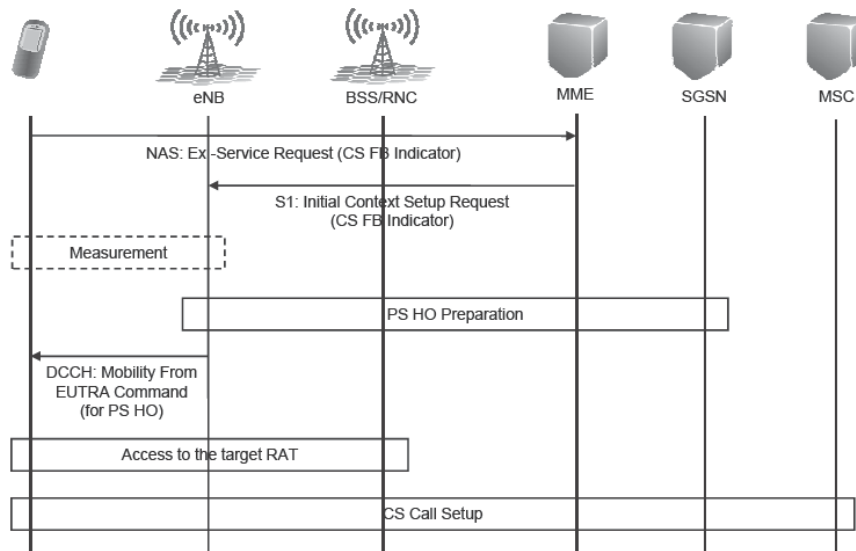

Figure 6.19 CS fallback with PS Handover

that the NAS: Ext-Service Request message is for the CS fallback to MME. Then MME indicates that S1: Initial Context Setup Request message is for the CS Fallback (CS FB). Depending on the target system and the capability of the target cell, eNodeB performs PS handover or cell change order procedure and the UE starts the CS call setup once it moves in to the target cell.

6.6.2.9 Context Transfer Between eNodeBs

During HO preparation, the source eNodeB should transfer the context of the UE to the target eNodeB so that the target eNodeB can take into account the configuration in the source cell and the handover command can contain only differences from the source configuration. This contains AS configuration, RRM configuration and AS Context. AS configuration contains the UE AS configuration configured via the RRC message exchange such as measurement configuration, radio resource configuration, security configuration, system information of source cell and UE ID. RRM configuration contains UE specific RRM information. AS Context contains UE Radio Access Capability and information for re-establishment.

6.6.2.10 NAS Direct Message Transfer Between Network and UE

NAS messages are transferred mainly via dedicated RRC messages, i.e. DL Information Transfer and UL Information transfer. During a bearer setup, however, necessary NAS messages should be transferred via the RRC Connection Complete message and RRC Connection Reconfiguration message.

6.6.2.11 UE capability transfer

UE transfers NAS UE capability (e.g. security UE capability) directly to MME via a NAS message and this is forwarded to eNodeB during the initial UE context setup. As UE capability may contain UTRAN and GERAN capability in addition to LTE capability, the information can be rather large. To reduce the overhead in the air interface during RRC_IDLE mode to RRC_CONNECTED mode transition, MME stores the UE AS capability as well and provides it to eNodeB during initial UE context setup. In case UE AS capability has been changed during RRC_IDLE or MME doesn't have the valid UE AS capability, however, MME does not provide UE AS capability during the initial UE context setup and eNodeB acquires UE AS capability directly from UE as shown in Figure 6.20.

6.6.2.12 Generic Error Handling

In UTRAN RRC, various error handling cases in the DCCH message had been specified thoroughly. For LTE, however, there was no desire to add complexity by specifying the handling of network error cases, such as ASN.1 errors. Thus only error handling for very important procedures are specified and the rest is unspecified. For example, when a RRC Connection Reconfiguration message has an ASN.1 error or integrity protection has failed, UE starts the RRC Connection Re-establishment procedure as shown in Figure 6.21. But for other error cases where the failure response message is not defined, the UE may just ignore the message. Also RRC Connection Re-establishment procedure is used to recover from radio link failure.

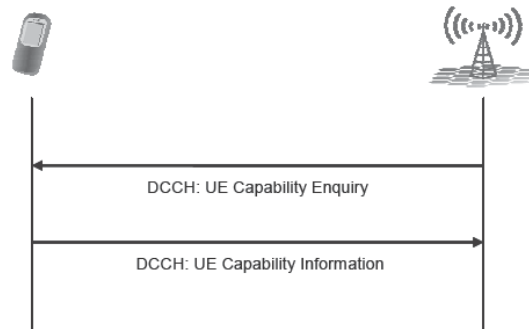

Figure 6.20 UE Capability Transfer procedure

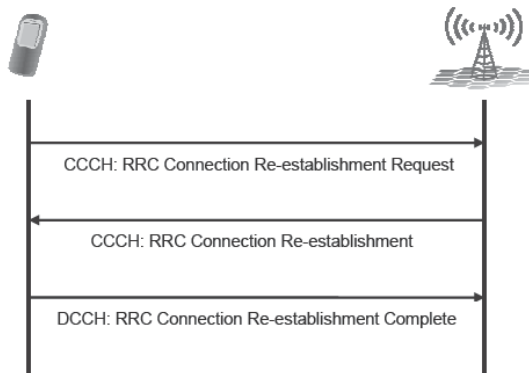

Figure 6.21 RRC Connection Re-establishment procedure

6.6.2.13 Support of Self-configuration and Self-optimization

To reduce the CAPEX and OPEX, there is natural interest in self-configuration and self-optimization solutions for the LTE system. For some key issues there are solutions agreed in Release 8 specifications to support the O&M system functionality in system setup and in fine tuning. X2 and S1 automatic setup has been specified in the X2 and S1 application protocol as addressed in Chapter 3, and the measurements to support the automatic neighbor cell relation are defined in the RRC specification as covered in Chapter 7.

6.7 X2 Interface Protocols

As introduced in Chapter 3, the LTE has the X2 interface between the eNodeBs. The X2 is a logical interface and even though normally drawn as a direct connection between eNodeBs, it is usually routed via the same transport connection as the S1 interface to the site. The X2 interface control and user plane protocol stacks are shown in Figure 6.22, as presented in Chapter 3. X2 is an open interface, similar to the Iur interface in WCDMA. Normally the X2 interface is only

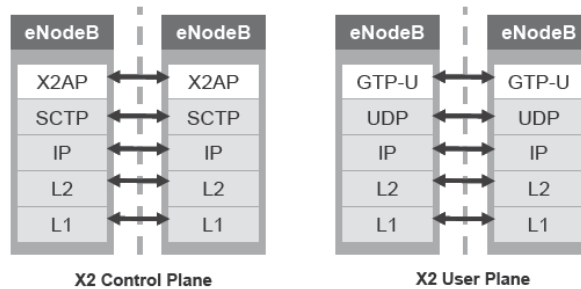

Figure 6.22 X2 interface User and Control Plane protocol stacks

used for control plane information but in connection with the handover, it can be temporarily used for user data forwarding. The key difference between the user plane and control plane X2 interface protocol stacks is the use of Stream Control Transmission Protocol (SCTP) for control plane transmission between eNodeBs. Use of SCTP enables reliable delivery of control plane information between eNodeBs, while for data forwarding, the User Datagram Protocol (UDP) was considered sufficient. The X2 Application Protocol (X2AP) covers the radio related signaling while the GPRS Tunneling Protocol, User Plane (GTP-U) is the protocol also used in the S1 interface for user data handling, as covered in Chapter 3.

The X2AP [12] functionalities are:

- Mobility management for Intra LTE mobility, as covered in more detail in Chapter 7. The handover message between eNodeBs is transmitted on the X2 interface.
- Load management to enable inter-cell interference coordination by providing information of the resource status, overload and traffic situation between different eNodeBs.
- Setting up and resetting of the X2 interface.
- Error handling for covering specific or general error cases.

6.7.1 Handover on X2 Interface

The X2 interface has a key role in the intra-LTE handover operation. The source eNodeB will use the X2 interface to send the Handover Request message to the target eNodeB. If the X2 interface does not exist between the two eNodeBs in question, then procedures need to be initiated to set one up before handover can be achieved, as explained in Chapter 6. The Handover Request message initiates the target eNodeB to reserve resources and it will send the Handover Request Acknowledgement message assuming resources are found, as shown in Figure 6.23.

There are different information elements provided (some optional) on the handover Request message, such as:

- Requested SAE bearers to be handed over.
- Handover restrictions list, which may restrict following handovers for the UE.
- Last visited cells the UE has been connected to if the UE historical information collection functionality is enabled. This has been considered to be useful in avoiding the ping-pong effects between different cells when the target eNodeB is given information on how the serving eNodeB has been changing in the past. Thus actions can be taken to limit frequent

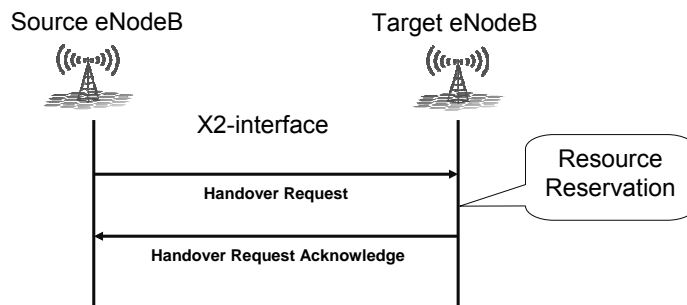

Figure 6.23 X2 Handover preparation over X2 interface

changes back and forth. Similar information is included in WCDMA Release 8 for consideration of similar cases with flat architecture.

Upon sending the handover Request message, the eNodeB will start the timer and if no response is received the handover preparation is cancelled (and an indication that the timer has expired is given to the target eNodeB). There is also a Handover Cancel message to cancel ongoing handover.

The Handover Request Acknowledge message contains more than just the information that the target eNodeB is able to accommodate (at least part) the requested SAE bearers to be handed over. The other information included is:

- GTP tunnel information for each SAE bearer to enable delivery of uplink and downlink PDUs;
- possible SAE bearers not admitted;
- a transparent container having handover information (actual RRC Connection Reconfiguration message) which the source eNodeB will then send to the UE as explained in section 6.6.2.8 and indicated as the handover commands in Chapter 7.

The SN Status Transfer procedure is intended to provide information on the status of each SAE bearer that will be transferred to the eNodeB. The PDCP-SN and HFN are provided for both the uplink and downlink direction for those SAE bearers where status presentation is applied. This will take place at the moment the source eNodeB stops assigning new PDCP SNs in downlink and stops forwarding data over the S1 interface to EPC.

The UE Context Release signals to the source eNodeB that ‘the control point’ for the UE has now moved to target eNodeB and basically that the source can now release all resources.

6.7.2 Load Management

There are three different measurements specified in Release 8 to support standardized operation for the load control and interference management over the X. The indications are:

- On the transmitter side there is the indication of the transmitted power level in the form of the Relative Narrowband Tx Power (RNTP) I.E.
- On the receiver side there are the received interference level and interference sensitivity.

All these are measured/estimated per Physical Resource Block (PRB) of 180kHz. The received interference level measurement (or rather indication) on the X2 interface is illustrated in Figure 6.24.

In the downlink direction the intention of the indication of the transmission power per PRB is to facilitate interference coordination between different eNodeBs. The eNodeB receiving the UL High Interference Indication information element should avoid scheduling the cell edge users on those PRBs where interference level is high in the neighboring eNodeB. The measurement of the TX power per PRB is illustrated in Figure 6.25.

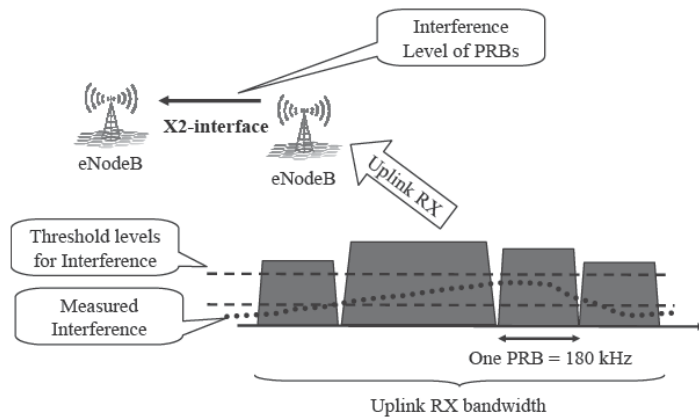

Figure 6.24 Interference level reporting over X2 interface

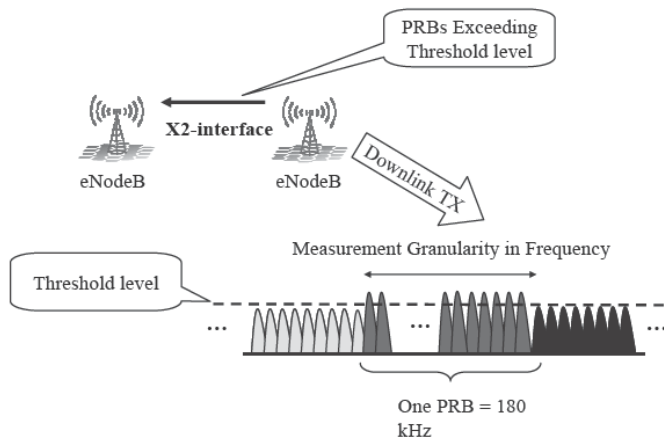

Figure 6.25 Transmission power vs threshold reporting over X2 interface

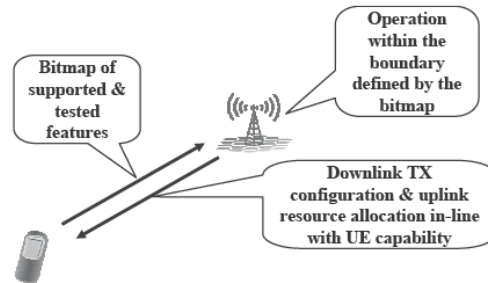

Figure 6.26 Signaling of the device capability at connection setup

6.8 Early UE Handling in LTE

In LTE, the 3GPP has requested feedback from the operators about the planned features for the first phase(s) of LTE deployment and then the first phase test cases will be based on the prioritization received. For features which have a lower priority in the testing area, UE capability signaling will be in place [11,13] to indicate to the network whether the feature is fully implemented and tested or not. This should avoid the problems faced with Release 99 deployment when many features mandatory for the UE were not supported in the networks (and thus not available for testing either) when the first networks were commercially opened. The latest plan for test case prioritization can be found in [14], with the expectation that work in 3GPP TSG RAN WG5 will be completed during 2009 for high priority cases (with some cases potentially still to be dropped from the list because of the high number of high priority test cases). The LTE test cases for signaling can be found from the recently created test specifications [15], and the completion of these test signaling test cases will naturally take longer than the actual radio protocol work in other groups as a stable signaling specification is needed before test cases can be finalized.

6.9 Summary

The LTE radio protocols follow a basic structure similar to WCDMA, but there are obvious differences due to the differences in radio technology. From the functional split the distribution is also partly different with the most notable difference being the handling of ciphering in the PDCP layer. The lack of an Iub-like interface reduces the need for radio protocol signaling on the internal interfaces as the eNodeB deals directly with RRC signaling between the UE and the network. The X2 interface is thus rather simple from the radio protocol perspective, with the key functionalities being to take care of the mobility related signaling for intra-LTE mobility as well as handling information exchange at the network level for cell level interference management. As with the WCDMA specifications, ASN.1 is used as the LTE radio protocol language to ensure straightforward extendibility with releases beyond LTE Release 8. For the UE capability signaling the input from the operator community has shaped what the first phased commercial UE will look like in terms of radio capability, and respectively bitmap is signaled in connection with the connection setup.

References

- [1] 3GPP Technical Specification, TS 36.321, 'Evolved Universal Terrestrial Radio Access (E-UTRA); Medium Access Control (MAC) protocol specification'.
- [2] 3GPP Technical Specification, TS 36.322, 'Evolved Universal Terrestrial Radio Access (E-UTRA); Radio Link Control (RLC) protocol specification'.
- [3] H. Holma, A. Toskala 'WCDMA for UMTS', 4th edition, Wiley, 2007.
- [4] IETF RFC 4995, 'The RObust Header Compression (ROHC) Framework'.
- [5] IETF RFC 4996, 'RObust Header Compression (ROHC): A profile for TCP/IP (ROHC-TCP)'.
- [6] IETF RFC 3095, 'RObust Header Compression (ROHC): Framework and four profiles: RTP, UDP, ESP and uncompressed'.
- [7] IETF RFC 3843, 'RObust Header Compression (ROHC): A compression profile for IP'.
- [8] IETF RFC 4815, 'RObust Header Compression (ROHC): Corrections and clarifications to RFC 3095'.
- [9] IETF RFC 5225, 'RObust Header Compression (ROHC) Version 2: Profiles for RTP, UDP, IP, ESP and UDP Lite'.
- [10] 3GPP Technical Specification, TS 36.323, 'Evolved Universal Terrestrial Radio Access (E-UTRA); Packet Data Convergence Protocol (PDCP) specification'.
- [11] 3GPP Technical Specification, TS 36.331, 'Evolved Universal Terrestrial Radio Access (E-UTRA); Radio Resource Control (RRC) protocol specification'.
- [12] 3GPP Technical Specification, TS 36.423, 'X2 application protocol (XSAP)', Version 8.3.0, September 2008.
- [13] 3GPP Technical Specification, TS 36.306, 'Evolved Universal Terrestrial Radio Access (E-UTRA); User Equipment (UE) radio access capabilities'.
- [14] 3GPP Tdoc R5-083674, 'LTE Features and Test Prioritisation' NTT DoCoMo.
- [15] 3GPP Technical Specification, TS 36.523-1, 'Evolved Universal Terrestrial Radio Access (E-UTRA) and Evolved Packet Core User Equipment (UE) conformance specification; Part 1: Protocol conformance specification (Release 8) v1.0.0, September 2008.

7

Mobility

Chris Callender, Harri Holma, Jarkko Koskela and Jussi Reunanen

7.1 Introduction

Mobility offers clear benefits to the end users: low delay services such as voice or real time video connections can be maintained while moving even in high speed trains. Mobility is beneficial also for nomadic services, such as laptop connectivity, since it allows a reliable connection to be maintained in the areas between two cells where the best serving cell is changing. This also implies a simple setup of the broadband connection without any location related configurations. Mobility typically has its price in the network complexity: the network algorithms and the network management get complex. The target of the LTE radio network is to provide seamless mobility while simultaneously keeping network management simple.

The mobility procedures can be divided into idle mode and connected mode for the attached UE (see Figure 7.1). Idle mode mobility is based on UE autonomous cell reselections according to the parameters provided by the network, thus this is quite similar to the one in WCDMA/HSPA today. The connected mode mobility in LTE, on the other hand, is quite different in LTE than in WCDMA/HSPA radio networks. The UE transition between idle and RRC connected mode is controlled by the network according to the UE activity and mobility. The algorithms for RRC connection management are described in Chapter 8.

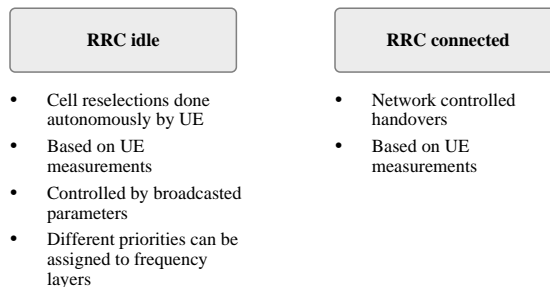

Figure 7.1 Idle mode and RRC connected mode mobility

LTE for UMTS: OFDMA and SC-FDMA Based Radio Access Edited by Harri Holma and Antti Toskala
© 2009 John Wiley & Sons, Ltd. ISBN: 978-0-470-99401-6

This chapter explains the mobility principles and procedures in the idle and active state. Idle state mobility management is described in section 7.2. The intra-frequency handover is presented in section 7.3. The inter-RAT handovers are covered in section 7.4. The differences in mobility between UTRAN and E-UTRAN are summarized in section 7.8. The voice handover from E-UTRAN Voice over IP to 2G/3G circuit switched voice is discussed in Chapter 10. The performance requirements related to mobility are described in Chapter 11.

The general description of LTE mobility is presented in [1], idle mode mobility is specified in [2], the performance requirements for radio resource management are defined in [3] and the relevant Radio Resource Control specifications in [4]. The rest of this chapter uses the term E-UTRAN for LTE and UTRAN for WCDMA.

7.2 Mobility Management in Idle State

7.2.1 Overview of Idle Mode Mobility

The UE chooses a suitable cell of the selected Public Land Mobile Network (PLMN) based on radio measurements. This procedure is known as cell selection. The UE starts receiving the broadcast channels of that cell and finds out if the cell is suitable for camping, which requires that the cell is not barred and that radio quality is good enough. After cell selection, the UE must register itself to the network thus promoting the selected PLMN to the registered PLMN. If the UE is able to find a cell that is deemed a better candidate for reselection according to reselection criteria (section 7.2.2), it reselects onto that cell and camps on it and again checks if the cell is suitable for camping. If the cell where the UE camps does not belong to at least one tracking area to which the UE is registered, location registration needs to be performed. An overview is shown in Figure 7.2.

A priority value can be assigned to PLMNs. The UE searches for higher priority PLMNs at regular time intervals and searches for a suitable cell if another PLMN has been selected. For example, the operator may have configured preferred roaming operators to the Universal Subscriber Identity Module (USIM) card. When the UE is roaming and not camped to the preferred operators, it tries periodically to find the preferred operator.

If the UE is unable to find a suitable cell to camp on or if the location registration fails, it attempts to camp on a cell irrespective of the PLMN identity, and enters a ‘limited service’ state which only allows emergency calls to be made.

The USIM must be inserted in the UE to perform the registration. UTRAN UE can use either the older SIM cards or the new USIM cards, while E-UTRAN uses only USIM. USIM can provide stronger protection against identity theft compared to SIM.

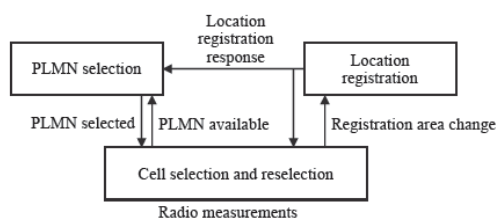

Figure 7.2 Idle mode overview

7.2.2 Cell Selection and Reselection Process

When UE is powered-on for the first time, it will start the Initial Cell Selection procedure. The UE scans all radio frequency (RF) channels in the E-UTRA bands according to its capabilities to find a suitable cell. On each carrier frequency, the UE needs only to search for the strongest cell. Once a suitable cell is found this cell is selected. Initial cell selection is used to ensure that the UE gets into service (or back to the service area) as fast as possible.

The UE may also have stored information about the available carrier frequencies and cells in the neighborhood. This information may be based on the system information or any other information the UE has acquired in the past – 3GPP specifications do not exactly define what kind of information the UE is required or allowed to use for Stored Information cell selection. If the UE does not find a suitable cell based on the stored information, the Initial Cell Selection procedure is started to ensure that a suitable cell is found.

For a cell to be suitable it has to fulfill S-criterion:

$$S_{rxlevel} > 0 \quad (7.1)$$

where

$$S_{rxlevel} > Q_{rxlevelmeas} - (Q_{rxlevmin} - Q_{rxlevminoffset}) \quad (7.2)$$

$Q_{rxlevelmeas}$ is the measured cell received level (RSRP), $Q_{rxlevmin}$ is the minimum required received level [dBm] and $Q_{rxlevminoffset}$ is used when searching for a higher priority PLMN.

Whenever UE has camped to a cell, it will continue to find a better cell as a candidate for reselection according to the reselection criteria. Intra-frequency cell reselection is based on the cell ranking criterion. To do this the UE needs to measure neighbor cells, which are indicated in the neighbor cell list in the serving cell. The network may also ban the UE from considering some cells for reselection, also known as blacklisting of cells. To limit the need to carry out reselection measurements it has been defined that if $S_{ServingCell}$ is high enough, the UE does not need to make any intra-frequency, inter-frequency or inter-system measurements. The intra-frequency measurements must be started when $S_{ServingCell} \leq S_{intrasearch}$. The inter-frequency measurements must be started when $S_{ServingCell} \leq S_{nonintrasearch}$.

In case the UE moves fast it is possible for the network to adjust the cell reselection parameters. The high (or medium) mobility state is based on the number of cell reselections, N_{CR} , within a pre-defined time, T_{RCmax} . High mobility is typically characterized by different parameter values for the hysteresis and for the reselection timer. To avoid adjusting reselection parameters in case the UE is ping-ponging between two cells, these cell reselections are not counted in the mobility state calculations. As the ‘speed’ estimation is based on the count of reselections it does not give an exact speed, just a rough estimate of UE movement, but nevertheless provides a means for the network to control UE reselection behavior dependent on the UE movement. The speed dependent scaling method is also applied in the RRC_CONNECTED state for connected mode mobility parameters.

7.2.2.1 Intra-frequency and Equal Priority Reselections

Cell ranking is used to find the best cell for UE camping for intra-frequency reselection or on reselection to equal priority E-UTRAN frequency. The ranking is based on the criterion R_s for the serving cell and R_n for neighboring cells:

$$\begin{aligned} R_s &= Q_{meas,s} + Q_{hyst} \\ R_n &= Q_{meas,n} + Q_{offset} \end{aligned} \quad (7.3)$$

where Q_{meas} is the RSRP measurement quantity, Q_{hyst} is the power domain hysteresis to avoid ping-pong and Q_{offset} is an offset value to control different frequency specific characteristics (e.g. propagation properties of different carrier frequencies) or cell specific characteristics. In the time domain, $T_{reselection}$ is used to limit overly frequent reselections. The reselection occurs to the best ranked neighbor cell if it is better ranked than the serving cell for a longer time than $T_{reselection}$. The Q_{hyst} provides hysteresis by requiring any neighbor cell to be better than the serving cell by an RRC configurable amount before reselection can occur. The $Q_{offsets,n}$ and $Q_{offsetfrequency}$ make it possible to bias the reselection toward particular cells and/or frequencies. The cell reselection parameters are illustrated in Figure 7.3.

7.2.2.2 Inter-frequency/RAT reselections

In the UTRAN, inter-frequency and inter-RAT reselections were based on the same ranking as intra-frequency reselections. It was seen that this is very difficult for the network to control as the measurement quantities of different RATs are different and the network needs to be able to control reselection between multiple 3GPP RATs (or even non-3GPP technologies). And as it was seen that operators would like to control how UE prioritizes camping on different RATs or frequencies of E-UTRAN, a new method for reselection handling between different RATs/frequencies (called layers from now on) was chosen. The method is known as absolute priority based reselection. Each layer is given a priority and based on this information the UE tries to camp on the highest priority frequency/RAT if it can provide decent service. In order for the UE to decide if decent service can be provided the network allocates each frequency/RAT a threshold ($Thresh_{x,high}$) which has to be fulfilled before reselection to such a layer is performed. A similar $T_{reselection}$ as in intra-frequency reselections is utilized, i.e. the new layer needs to fulfill the threshold for consecutive time of $T_{reselection}$ before reselection is performed. This is used to eliminate reselections if just temporary fading for the evaluated frequency occurs. To make reselection to a lower priority layer the UE will not reselect to that if the higher priority layer is still above the threshold or if the lower priority frequency is not above another threshold ($Thresh_{x,low}$).

The main parameters for controlling idle mode mobility are shown in Table 7.1.

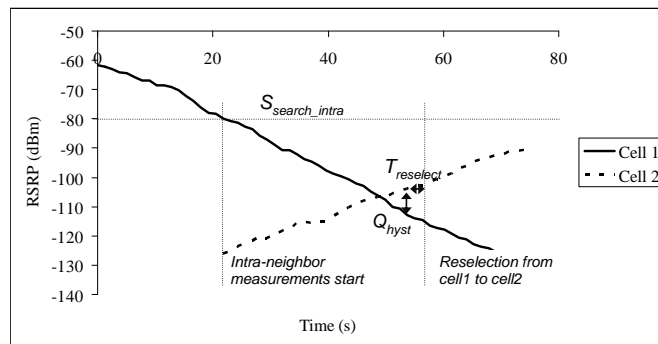

Figure 7.3 Idle mode intra-frequency cell reselection algorithm

Table 7.1 Main parameters for idle mode mobility

Parameters	Description
Q_{hyst}	Specifies the hysteresis value for ranking criteria. The hysteresis is required to avoid ping-ponging between two cells.
$T_{reselection}$	Gives the cell reselection timer value. The cell reselection timer together with the hysteresis is applied to control the unnecessary cell reselections.
$Q_{rxlevmin}$	Specifies the minimum required received level in the cell in dBm. Used in the S-criterion, i.e. in the cell selection process.
$S_{intrasearch}$ $S_{nonintrasearch}$	Specifies the threshold (in dB) for intra-frequency, inter-frequency and inter-RAN measurements. UE is not required to make measurements if $S_{servingcell}$ is above the threshold.
N_{CR} T_{RCmax}	Specifies when to enter the medium or high mobility state: if the number of cell reselections within time T_{RCmax} is higher than N_{CR} , the UE enters the medium or higher mobility state.
$Thresh_{x,high}$	This specifies the threshold used by the UE when reselecting towards the higher priority frequency X than currently serving frequency.
$Thresh_{x,low}$	This specifies the threshold used in reselection towards frequency X from a higher priority frequency.

7.2.3 Tracking Area Optimization

The UE location in RRC idle is known by the Mobility Management Entity (MME) with the accuracy of the tracking area. The size of the tracking area can be optimized in network planning. A larger tracking area is beneficial to avoid tracking area update signaling. On the other hand, a smaller tracking area is beneficial to reduce the paging signaling load for the incoming packet calls. The corresponding concept in UTRAN is called a Routing area, which typically covers a few hundred base stations. The concept of the tracking area is illustrated in Figure 7.4.

UE can be assigned multiple tracking areas to avoid unnecessary tracking area updates at the tracking area borders, e.g. when the UE is ping-ponging between cells of two different tracking areas. UE can also be assigned both a LTE tracking area and a UTRAN routing area to avoid signaling when changing between the two systems.

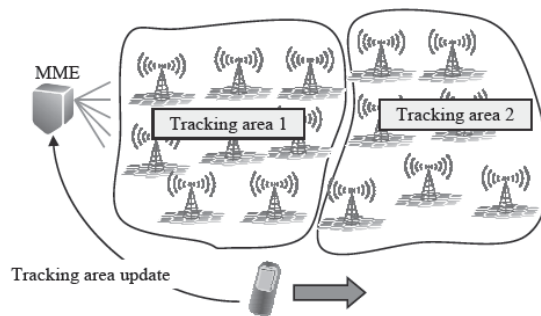

Figure 7.4 Tracking area concept

7.3 Intra-LTE Handovers

UE mobility is solely controlled by the handovers when the RRC connection exists. Thus there is no UTRAN type of state as CELL_PCH where UE based mobility is possible while UE is in RRC_CONNECTED state. The handovers in E-UTRAN are based on the following principles:

- 1 The handovers are network controlled. E-UTRAN decides when to make the handover and what the target cell is.
- 2 The handovers are based on the UE measurements. The UE measurements and measurement reporting is controlled by parameters given by E-UTRAN.
- 3 The handovers in E-UTRAN are targeted to be lossless by using packet forwarding between the source and the target eNodeB.
- 4 The core network S1 connection is updated only when the radio handover has been completed. This approach is called Late path switch. The core network has no control on the handovers.

The E-UTRAN handover procedure, measurements, signaling and neighborlist control are described below.

7.3.1 Procedure

An overview of the intra-frequency handover procedure is shown in Figure 7.5. The UE is moving from left to right. In the initial phase the UE has user plane connection to the source eNodeB and further to the System Architecture Evolution Gateway (SAE GW). The S1 signaling connection exists between eNodeB and MME. When the target cell fulfills the measurement reporting

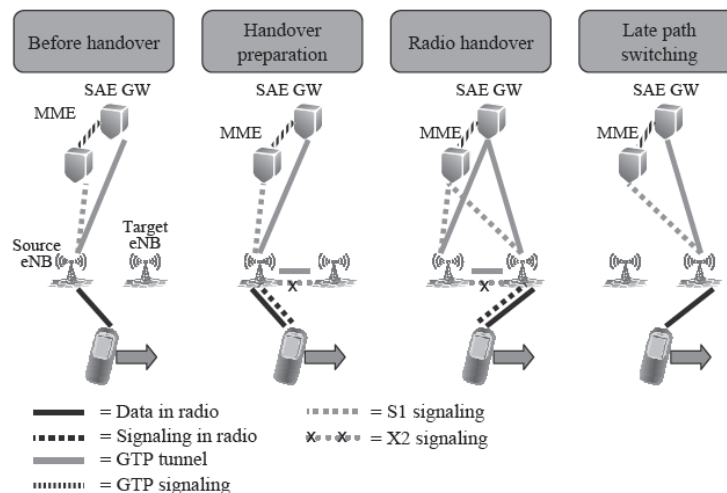

Figure 7.5 Intra-frequency handover procedure

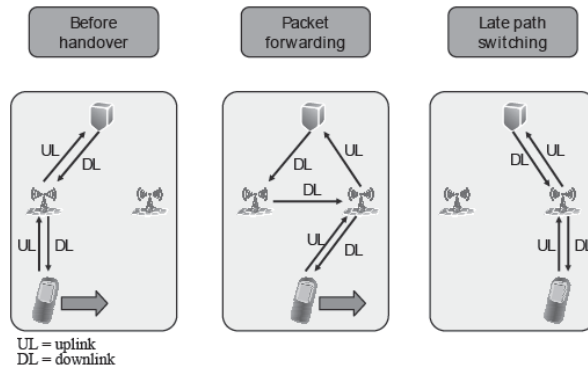

Figure 7.6 User plane switching in handover

threshold, the UE sends the measurement report to the eNodeB. The eNodeB establishes the signaling connection and GTP (GPRS Tunneling Protocol) tunnel to the target cell. Once the target eNodeB has the resource available, the source eNodeB sends the handover command to the UE. The UE can switch the radio connection from the source to the target eNodeB. The core network is not aware of the handover at this point in time. The core network connection is finally updated and this procedure is called Late path switching.

The user plane switching is illustrated in Figure 7.6. The user plane packets in downlink are forwarded from the source eNodeB to the target eNodeB over the X2 interface before Late path switching. The X2 interface enables lossless handover. The source eNodeB forwards all downlink RLC SDUs (Service Data Units) that have not been acknowledged by the UE. The target eNodeB re-transmits and prioritizes all downlink RLC SDUs forwarded by the source eNodeB as soon as it obtains them. It may happen that some packets were already received by the UE from the source eNodeB but the source eNodeB did not receive the acknowledgement. The target eNodeB will then retransmit the packets unnecessarily and the UE receives the same packet twice. Therefore, the UE must be able to identify and remove duplicate packets.

In the uplink direction, the source eNodeB forwards all successfully received uplink RLC SDUs to the packet core. The UE re-transmits the uplink RLC SDUs that have not been acknowledged by the source eNodeB. It may happen also in uplink that some packets are sent twice. The reordering and the duplication avoidance in uplink are done in the packet core.

The packet forwarding takes place only for a short time until the late path switching has been completed. Therefore, the packet forwarding does not consume excessive transport resources and X2 interface requirements are not significant from the network dimensioning point of view. The packets in the uplink direction can be sent directly from the target eNodeB to SAE GW.

7.3.2 Signaling

The detailed signaling messages during the handover procedure are described in this section. The procedure is divided into three parts: handover preparation (Figure 7.7), handover execution (Figure 7.8) and handover completion (Figure 7.9).

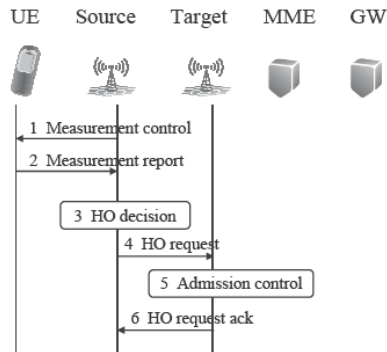

Figure 7.7 Handover preparation

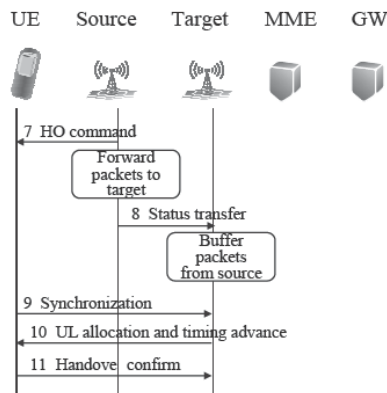

Figure 7.8 Handover execution

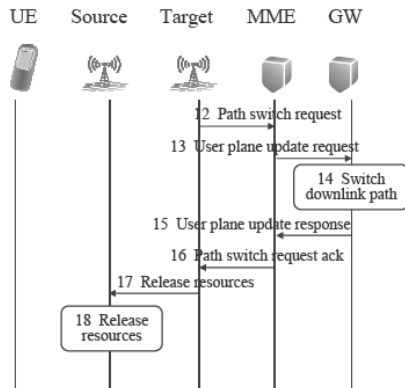

Figure 7.9 Handover completion

- 1 The source eNodeB configures the UE measurement procedures with a MEASUREMENT CONTROL message. The message defines the measurement reporting thresholds.
- 2 When the target cell fulfills the reporting threshold, the UE sends a MEASUREMENT REPORT to the eNodeB. The typical reporting is event triggered where the UE sends measurements only when the reporting threshold has been fulfilled. It is also possible to configure periodic reporting.
- 3 The source eNodeB makes the handover decision based on the UE report. For intra-frequency handovers, the UE needs to be connected to the cell with the lowest path loss and the network has practically no freedom in deciding the handover target. For inter-frequency and inter-RAT handovers, the eNodeB can also take the load and service information into account. The operator may want to balance the loading between frequencies and may want to push certain services to certain frequency layers or systems.
- 4 The source eNodeB sends a HANDOVER REQUEST to the target eNodeB.
- 5 The target eNodeB performs the admission control. For intra-frequency handovers the network has little freedom in blocking the new connection since the UE transmission will anyway cause the uplink interference to the target cell even if the UE does not have the connection to the target cell. Actually, the uplink interference can be minimized by allowing the UE to connect to the cell with lowest path loss. If there are simply no resources in the target cell, the network may need to release the connection to avoid excessive interference.
- 6 The target eNodeB sends the HANDOVER REQUEST ACKNOWLEDGE to the source eNodeB. The target eNodeB is now ready to receive the incoming handover.
- 7 The source eNodeB sends the HANDOVER COMMAND to the UE. The source eNodeB starts forwarding the downlink packets to the target eNodeB.
- 8 The source eNodeB sends the status information to the target eNodeB indicating the packets that were acknowledged by the UE. The target eNodeB starts buffering the forwarded packets.
- 9 The UE makes the final synchronization to target eNodeB and accesses the cell via a RACH procedure. The pre-synchronization is already obtained during the cell identification process.
- 10 The target eNodeB gives the uplink allocation and timing advance information to the UE.
- 11 The UE sends HANDOVER CONFIRM to the target eNodeB. The target eNodeB can now begin to send data to the UE.
- 12 The target eNodeB sends a PATH SWITCH message to the MME to inform it that the UE has changed cell.
- 13 The MME sends a USER PLANE UPDATE REQUEST message to the Serving Gateway.
- 14 The Serving Gateway switches the downlink data path to the target eNodeB.
- 15 The Serving Gateway sends a USER PLANE UPDATE RESPONSE message to the MME.
- 16 The MME confirms the PATH SWITCH message with the PATH SWITCH ACK message.
- 17 The target eNodeB sends RELEASE RESOURCE to the source eNodeB, which allows the source eNodeB to release the resources.
- 18 The source eNodeB can release radio and control plane related resources associated with the UE context.

7.3.3 Handover Measurements

Before the UE is able to send the measurement report, it must identify the target cell. The UE identifies the cell using the synchronization signals (see Chapter 5). The UE measures the signal level using the reference symbols. There is no need for the E-UTRAN UE to read the Broadcast channel during the handover measurements. In UTRAN the UE needs to decode the Broadcast channel to find the system frame number, which is required to time-align the soft handover transmissions in downlink. There is no such requirement in E-UTRAN as there is no soft handover.

When the reporting threshold condition is fulfilled, the UE sends Handover measurements to the eNodeB

7.3.4 Automatic Neighbor Relations

The neighborlist generation and maintenance has turned out to be heavy work in the existing mobile networks especially when the networks are expanded and new sites are being added. A missing neighbor is a common reason for the call drops. The UE in E-UTRAN can detect the intra-frequency neighbors without neighborlists, leading to simpler network management and better network quality. The automatic neighbor relation functionality is illustrated in Figure 7.10. The UE is moving towards a new cell and identifies the Physical Cell Identity (PCI) based on the synchronization signals. The UE sends a measurement report to eNodeB when the handover reporting threshold has been fulfilled. The eNodeB, however, does not have X2 connection to that cell. The physical cell identity (ID) is not enough to uniquely identify the cell since the number of physical cell IDs is just 504 while the large networks can have tens of thousands of cells. Therefore, the serving eNodeB requests the UE to decode the global cell ID from the broadcast channel of the target cell. The global cell ID identifies the cell uniquely. Based on the global cell ID the serving eNodeB can find the transport layer address of the target cell using the information from the MME and set up a new X2 connection. The serving eNodeB can then proceed with the handover.

New X2 connections need to be created and some old unused connections can be removed when new cells are added to the network or when changes are done to the antenna systems.

The intra-frequency neighborlist generation is simple since the UE can easily identify all the cells within the same frequency. In order to create inter-RAT or inter-frequency neighbors the

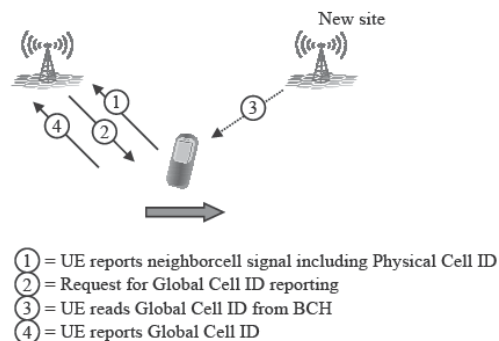

Figure 7.10 Automatic intra-frequency neighbor identification. BCH, broadcast channel

eNodeB must ask the UE to make inter-RAT or inter-frequency measurements. The eNodeB must also schedule gaps in the signal to allow the UE to perform the measurements.

7.3.5 Handover Frequency

The handover frequency in the network depends on a number of factors:

- The actual mobility of the users compared to the cell size. The statistics from HSPA networks can be used to estimate the impact of the mobility.
- The user activity. The typical voice activity is 30–50 mErl, which is 3–5% activity. Laptop users and smart phone users may have a RRC connection active all the time since the always-on applications keep sending packets at frequent intervals. User activity may therefore increase considerably in the future.
- The mobility solution of the system. The total number of handovers will likely be higher in LTE than in HSPA since part of the mobility in HSPA is carried out by the UE itself making cell reselections in Cell_PCH and Cell_FACH states, while LTE always uses handovers.

The impact of user mobility is illustrated by comparing the number of handovers for HSPA users, which are mostly laptop users today, and for WCDMA users, which are mostly voice users. An example of the WCDMA handover frequency is illustrated in Figure 7.11. The handover frequency is collected per cell per hour. The median active set update frequency

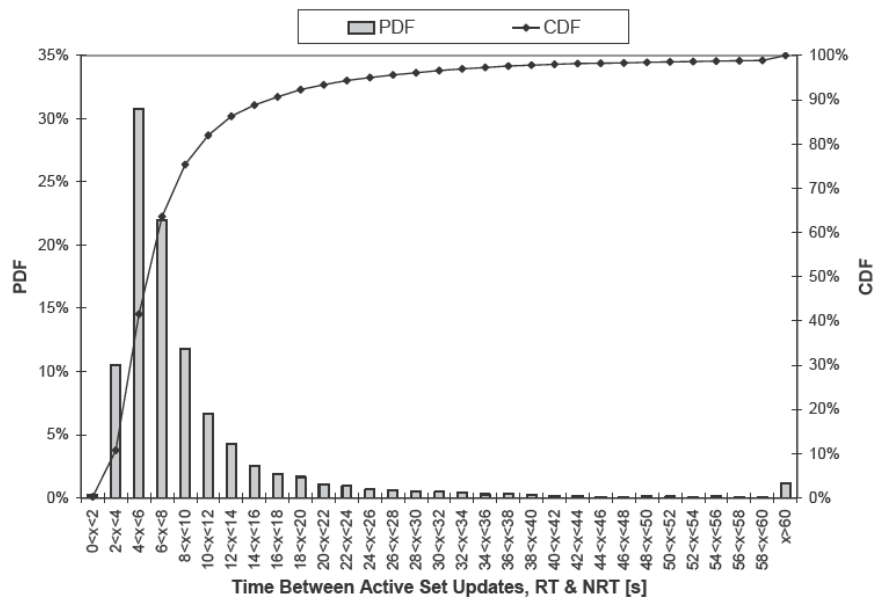

Figure 7.11 Example of WCDMA active set update frequency in 3G networks. PDF, probability density function; CDF, cumulative density function; RT, real time; NRT, non-real time

is 6s, corresponding to approximately 12 s handover frequency. Each HSPA cell change or LTE handover corresponds typically to two active set updates in WCDMA: add and drop. An example of the HSPA cell change frequency is shown in Figure 7.12. Both Figure 7.11 and Figure 7.12 were collected from the same network at the same time. The median number of HSPA serving cell changes is one serving cell change for every 120–140s for each active connection. That indicates that current laptop HSPA users have clearly lower mobility than the WCDMA voice users. The HSPA cell change used 2 dB handover hysteresis where the target HSPA serving cell has to have 2 dB higher E_c/N_0 than the current HSPA serving cell.

It is expected that the LTE mobility will initially be similar to HSPA mobility since LTE devices are likely to be USB modems. The introduction of handheld LTE devices will increase the handover rate per connection.

Figure 7.11 and Figure 7.12 show that the handover frequency varies considerably depending the environment, cell size and user mobility. For 20% of the cells the HSPA service cell change rate is below 40s. There are, however, 15% of cells where the cell change rate is more than 500s.

The most typical application today is voice with a normal activity of 3–5%. The application activity will increase with always on applications. Laptops keep sending small packets in the background implying that the RRC connection needs to be maintained 100% of the time. The same situation applies to the handheld devices that run always on applications such as push-email, push-to-talk or presence. Even if the end user does not use the application actively, the RRC connection is still active from the system perspective due to the transmission of the

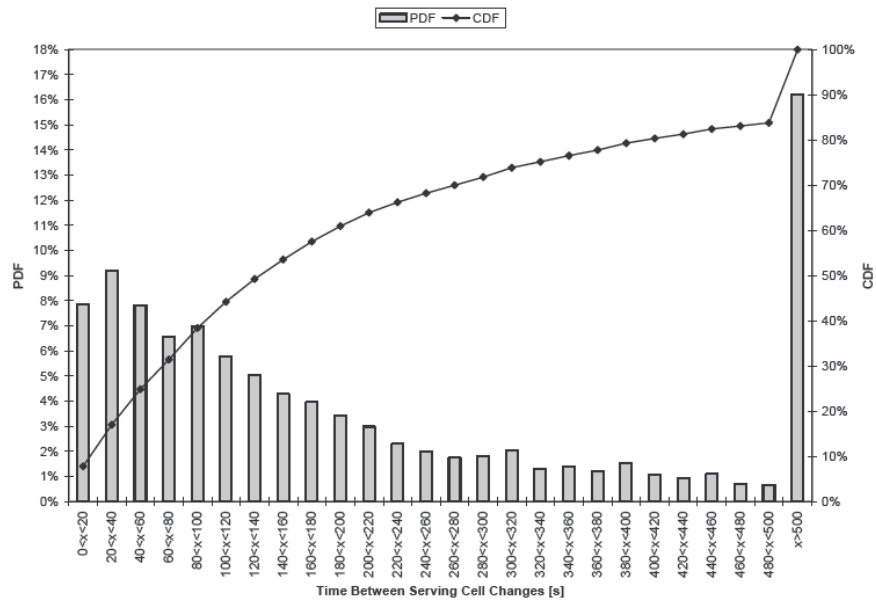

Figure 7.12 Example of HSPA Serving Cell Change frequency in 3G networks

keep alive messages, reception of emails and presence updates. The user activity may increase from 5% to 100% due to the new applications – that is a 20 times higher activity than today. Therefore, the number of handovers may be considerably higher with new applications in the LTE network where all the mobility is carried by handovers for RRC connected users.

7.3.6 Handover Delay

The fast handover process is essential when the signal level from the source cell fades fast while the signal from the target cell increases. This may happen when the UE drives around the corner. The signal levels are illustrated in Figure 7.13. The critical point is that the UE must be able to receive the handover command from the source eNodeB before the signal-to-interference ratio gets too low. The handover reliability in this scenario can be improved by suitable window and averaging parameters as well as by minimizing the network delay in responding to the UE measurement report.

7.4 Inter-system Handovers

The inter-RAT handovers refer to the inter-system handovers between E-UTRAN and GERAN, UTRAN or cdma2000® both for real time and for non-real time services. The inter-RAT handover is controlled by the source access system for starting the measurements and deciding the handover execution. The inter-RAT handover is a backwards handover where the radio resources are reserved in the target system before the handover command is issued to the UE. As the GERAN system does not support Packet Switched Handover (PS HO), the resources are not reserved before the handover. The signaling is carried via the core network as there are no direct interfaces between the different radio access systems. The inter-RAT handover is similar to intra-LTE handover in the case where the packet core node is changed.

All the information from the target system is transported to the UE via the source system transparently. The user data can be forwarded from the source to the target system to avoid loss of user data. To speed up the handover procedure there is no need for the UE to have any

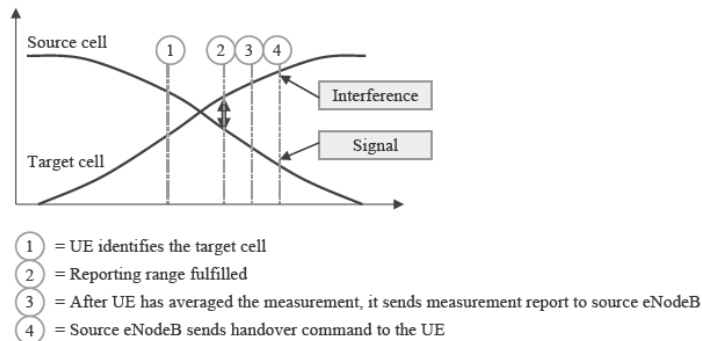

Figure 7.13 Handover timings

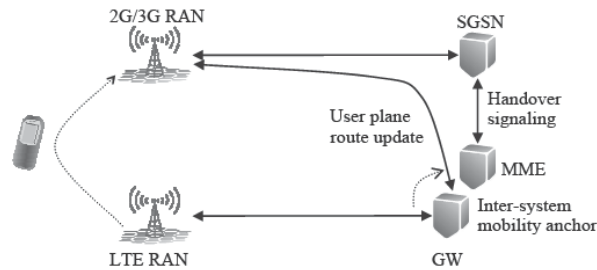

Figure 7.14 Overview of inter-RAT handover from E-UTRAN to UTRAN/GREAN

signaling to the core network. The security and QoS context is transferred from the source to the target system.

The Serving GW can be used as the mobility anchor for the inter-system handovers.

The overview of the inter-system handover is shown in Figure 7.14. The interfaces are described in Chapter 3.

The interruption time in inter-system handovers can be very small. The interruption time from the UE point of view is defined as the time between the last TTI containing a transport block on the E-UTRAN side and the time the UE starts transmission of the new uplink DPCH on the UTRAN side. This interruption time can be as low as 50 ms plus the frame alignments. When the UE enters UTRAN, it will initially be connected to one cell and the soft handover links can be added separately. The UE cannot go directly into soft handover in UTRAN since the UE is not required to read the system frame number (SFN) from UTRAN before the inter-system handover.

E-UTRAN also supports mobility to and from non-3GPP radio systems, such as cdma2000®.

7.5 Differences in E-UTRAN and UTRAN Mobility

The main differences between UTRAN and E-UTRAN mobility are summarized below and listed in Table 7.2. The idle mode mobility is similar in UTRAN and E-UTRAN for intra-frequency reselections. But a new priority based reselection method was chosen in E-UTRAN to ease network planning for the presence of multiple different RATs. The flat architecture in E-UTRAN brings some differences to the active mode mobility.

In UTRAN the UE must update the location both to the circuit switched core network (Location areas) and to the packet core network (Routing areas) while E-UTRAN only uses Tracking areas (packet core). For so-called Circuit Switched Fall Back (CSFB) handover, the CS core network can send a paging message to the E-UTRAN UE. In that case the MME maps the Tracking area to the Location area. This procedure is explained in Chapter 10.

E-UTRAN uses handovers for all UEs that have RRC connection. The UE in UTRAN makes cell reselections without network control even if a RRC connection exists when the UE is in Cell_FACH, Cell_PCH or in URA_PCH states. Such states are not used in E-UTRAN. The UE location is known with UTRAN Registration area accuracy in URA_PCH state while the UE location is known with the accuracy of one cell in E-UTRAN whenever the RRC connection exists.

Table 7.2 UTRAN and E-UTRAN differences in mobility

UTRAN	E-UTRAN	Notes
Location area (CS core)	Not relevant since no CS connections	For CS fallback handover, MME maps Tracking area to Location area
Routing area	Tracking area	
Soft handover is used for WCDMA uplink and downlink and for HSUPA uplink	No soft handovers	
Cell_FACH, Cell_PCH, URA_PCH	No similar RRC states	E-UTRAN always uses handovers for RRC connected users
RNC hides most of mobility	Core network sees every handover	Flat architecture HSPA is similar to E-UTRAN
Neighbor cell lists required	No need to provide cell specific information, i.e. only carrier frequency is required, but the network can provide cell specific reselection parameters (e.g. Q_{offset}) if desired	Also UTRAN UE can use detected cell reporting to identify a cell outside the neighborlist

The WCDMA system uses soft handovers both in uplink and in downlink. The HSPA system uses soft handovers in uplink, but not in downlink. In the LTE system a need for soft handovers was no longer seen, thus simplifying the system significantly.

The Radio Network Controller (RNC) typically connects hundreds of base stations and hides the UE mobility from the core network. The packet core can only see Serving RNC (S-RNC) relocations when the SRNC is changed for the UE. For E-UTRAN, the packet core network can see every handover. 3GPP has specified the flat architecture option for UTRAN in Release 7. That architecture is known as Internet-HSPA. The RNC functionalities are embedded to the Node-B. Internet-HSPA mobility is similar to E-UTRAN mobility: serving RNC relocation over the Iur interface is used in the same way as E-UTRAN handover over the X2 interface.

7.6 Summary

3GPP E-UTRAN as well as the SAE standards are designed to support smooth mobility within E-UTRAN (LTE) and between E-UTRAN and GERAN/UTRAN (2G/3G RAN) and to cdma2000[®]. The idle mode mobility follows the same principles as in 2G/3G networks where the UE makes cell reselection autonomously. E-UTRAN adds the flexibility that the UE can be allocated multiple tracking areas. The network knows the UE location with the accuracy of the tracking area.

The handover is used in E-UTRAN RRC connected mode and is controlled by the network. The intra-frequency handover is based on fast hard handover in the radio followed by the core network path switching. The E-UTRAN flat architecture implies that the core network sees every handover while in UTRAN system most of the handovers are hidden by RNC. Additionally, the number of handovers in E-UTRAN will likely increase compared to UTRAN since the mobility is controlled by handovers for all RRC connected users.

The E-UTRAN system can be operated without pre-defined neighbor cell lists, which makes the network operation simpler than in GERAN or UTRAN networks.

References

- [1] 3GPP Technical Specification 36.300 'E-UTRAN Overall Description; Stage 2', v. 8.6.0.
- [2] 3GPP Technical Specification 36.304 'User Equipment (UE) procedures in idle mode', v. 8.3.0.
- [3] 3GPP Technical Specification 36.133 'Requirements for support of radio resource management', v. 8.3.0.
- [4] 3GPP Technical Specification 36.331 'Radio Resource Control (RRC); Protocol specification', v. 8.3.0.

8

Radio Resource Management

Harri Holma, Troels Kolding, Daniela Laselva, Klaus Pedersen, Claudio Rosa and Ingo Viering

8.1 Introduction

The role of Radio Resource Management (RRM) is to ensure that the radio resources are efficiently used, taking advantage of the available adaptation techniques, and to serve the users according to their configured Quality of Service (QoS) parameters. An overview of primary RRM functionalities is given in section 8.2, and the chapter then moves on to discuss QoS parameters and admission control issues in section 8.3. Next, details related to both downlink and uplink adaptation and scheduling methodologies are discussed in sections 8.4 and 8.5. Interference coordination is discussed in section 8.6, and a discussion of discontinuous reception is included in section 8.7. The Radio Resource Control (RRC) connection management is introduced in section 8.8, and the chapter is summarized in section 8.9.

8.2 Overview of RRM Algorithms

Figure 8.1 shows an overview of the user-plane and control-plane protocol stack at the eNodeB, as well as the corresponding mapping of the primary RRM related algorithms to the different layers. The family of RRM algorithms at the eNodeB exploits various functionalities from Layer 1 to Layer 3 as illustrated in Figure 8.1. The RRM functions at Layer 3, such as QoS management, admission control, and semi-persistent scheduling, are characterized as semi-dynamic mechanisms, since they are mainly executed during setup of new data flows. The RRM algorithms at Layer 1 and Layer 2, such as Hybrid Adaptive Repeat and Request (HARQ) management, dynamic packet scheduling, and link adaptation, are highly dynamic functions with new actions conducted every Transmission Time Interval (TTI) of 1 ms. The latter RRM functions are therefore characterized as *fast dynamic*.

The Channel Quality Indicator (CQI) manager at Layer 1 processes the received CQI reports (downlink) and Sounding Reference Signals (SRSs) (uplink) from active users in the cell. Each received CQI report and SRS is used by the eNodeB for scheduling decisions and

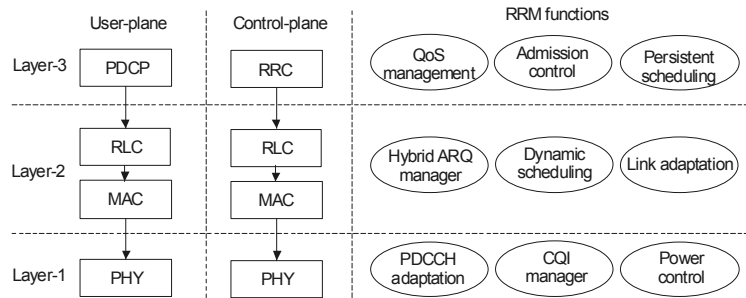

Figure 8.1 Overview of the eNodeB user plane and control plane protocol architecture, and the mapping of the primary RRM functionalities to the different layers. PHY = Physical layer; MAC = Medium access control; RLC = Radio link control; PDCP = Packet data convergence protocol; PDCCH = Physical downlink control channel

for link adaptation purposes in downlink and uplink, respectively. This chapter presents the Layer 3 and Layer 2 RRM functions except for the semi-persistent scheduling, which is part of the voice description in Chapter 10 as semi-persistent scheduling is typically used for voice service. The Layer 1 functions are covered in Chapter 5.

3GPP specifies the RRM related signaling but the actual RRM algorithms in the network are not defined in 3GPP – those algorithms can be vendor and operator dependent.

8.3 Admission Control and QoS Parameters

The eNodeB admission control algorithm decides whether the requests for new Evolved Packet System (EPS) bearers in the cell are granted or rejected. Admission control (AC) takes into account the resource situation in the cell, the QoS requirements for the new EPS bearer, as well as the priority levels, and the currently provided QoS to the active sessions in the cell. A new request is only granted if it is estimated that QoS for the new EPS bearer can be fulfilled, while still being able to provide acceptable service to the existing in-progress sessions in the cell having the same or higher priority. Thus, the admission control algorithm aims at only admitting new EPS bearers up to the point where the packet scheduler in the cell can converge to a feasible solution where the promised QoS requirements are fulfilled for at least all the bearers with high priority. The exact decision rules and algorithms for admission control are eNodeB vendor specific and are not specified by 3GPP. As an example, possible vendor specific admission control algorithms for OFDMA based systems are addressed in [1]. Similarly, the QoS-aware admission control algorithms in [2] and [3] can be extended to LTE.

Each LTE EPS bearer has a set of associated QoS parameters in the same way as GERAN and UTRAN radios. All the packets within the bearer have the same QoS treatment. It is possible to modify QoS parameters of the existing bearers dynamically. It is also possible to activate another parallel bearer to allow different QoS profiles for different services simultaneously. The new bearer can be initiated by the UE or by the packet core network.

The QoS profile of the EPS bearer consists of the following related parameters [4]:

- allocation retention priority (ARP)

- uplink and downlink guaranteed bit rate (GBR)
- QoS class identifier (QCI).

The GBR parameter is only specified for EPS GBR bearers. For non-GBR bearers, an aggregate MBR (AMBR) is specified. The ARP parameter, being an integer in the range 1–16, is primarily for prioritization when conducting admission control decisions. The QCI is a pointer to a more detailed set of QoS attributes. The QCI includes parameters like the Layer 2 packet delay budget, packet loss rate and scheduling priority. These parameters can be used by the eNodeB to configure the outer ARQ operation point for the RLC protocol, and the Layer 2 packet delay budget is used by the eNodeB packet scheduler, i.e. to prioritize certain queues in order to fulfill certain head-of-line packet delay targets.

3GPP specifications define a mapping table for nine different QCIs and their typical services, see Table 8.1. Further QCI values may be defined later depending on the need and on the new emerging services.

An additional QoS parameter called the prioritized bit rate (PBR) is specified for the uplink per bearer. The PBR is introduced to avoid the so-called uplink scheduling starvation problem that may occur for UE with multiple bearers. A simple rate control functionality per bearer is therefore introduced for sharing of uplink resources between radio bearers. RRC controls the uplink rate control function by giving each bearer a priority and a PBR. The PBR is not necessarily related to the GBR parameter signaled via S1 to the eNodeB, i.e. a PBR can also be defined for non-GBR bearers. The uplink rate control function ensures that the UE serves its radio bearer(s) in the following sequence [6]:

- all the radio bearer(s) in decreasing priority order up to their PBR;
- all the radio bearer(s) in decreasing priority order for the remaining resources.

When the PBR is set to zero for all RBs, the first step is skipped and the radio bearer(s) are served in strict priority order.

The QoS concept in LTE has been simplified compared to WCDMA/HSPA in which more than ten different QoS parameters are signaled over the Iu interface. LTE also enables a network activated GBR bearer without the need for the terminal application to initiate the request. There

Table 8.1 QCI characteristics for the EPS bearer QoS profile [4] [5]

QCI #	Priority	L2 packet delay budget	L2 packet loss rate	Example services
1 (GBR)	2	100 ms	10 ⁻²	Conversational voice
2 (GBR)	4	150 ms	10 ⁻³	Conversational video
3 (GBR)	5	300 ms	10 ⁻⁶	Buffered streaming
4 (GBR)	3	50 ms	10 ⁻³	Real-time gaming
5 (non-GBR)	1	100 ms	10 ⁻⁶	IMS signaling
6 (non-GBR)	7	100 ms	10 ⁻³	Live streaming
7 (non-GBR)	6	300 ms	10 ⁻⁶	Buffered streaming, email,
8 (non-GBR)	8	300 ms	10 ⁻⁶	browsing, file download,
9 (non-GBR)	9	300 ms	10 ⁻⁶	file sharing, etc.

is, however, also more need for well performing QoS in LTE since circuit switched connections are not possible and voice is carried as Voice over IP (VoIP).

8.4 Downlink Dynamic Scheduling and Link Adaptation

Dynamic packet scheduling and link adaptation are key features to ensure high spectral efficiency while providing the required QoS in the cell. In this section, the general framework as well as specific algorithms and applications are presented.

8.4.1 Layer 2 Scheduling and Link Adaptation Framework

The controlling RRM entity at Layer 2 is the dynamic packet scheduler (PS), which performs scheduling decisions every TTI by allocating Physical Resource Blocks (PRBs) to the users, as well as transmission parameters including modulation and coding scheme. The latter is referred to as link adaptation. The allocated PRBs and selected modulation and coding scheme are signaled to the scheduled users on the PDCCH. The overall packet scheduling goal is to maximize the cell capacity, while making sure that the minimum QoS requirements for the EPS bearers are fulfilled and there are adequate resources also for best-effort bearers with no strict QoS requirements. The scheduling decisions are carried out on a per user basis even though a user has several data flows. Actually, each active user with an EPS bearer has at least two Layer 2 data flows; namely a control plane data flow for the RRC protocol and one or multiple user plane data flows for EPS bearers. Each of the data flows are uniquely identified with a 5-bit Logical Channel Identification (LCID) field. Given the scheduled Transport Block Size (TBS) for a particular user, the MAC protocol decides how many data are sent from each LCID.

As illustrated in Figure 8.2, the packet scheduler interacts closely with the HARQ manager as it is responsible for scheduling retransmissions. For downlink, asynchronous adaptive HARQ is supported with 8 stop-and-wait channels for each code-word, meaning that the scheduler has full flexibility to dynamically schedule pending HARQ retransmissions in the time and the frequency

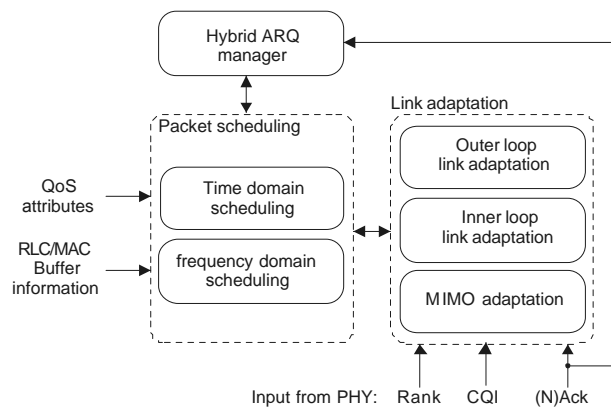

Figure 8.2 Layer 2 functionalities for dynamic packet scheduling, link adaptation, and HARQ management

domain. For each TTI, the packet scheduler must decide between sending a new transmission or a pending HARQ transmission to each scheduled user, i.e. a combination is not allowed. The link adaptation provides information to the packet scheduler of the supported modulation and coding scheme for a user depending on the selected set of PRBs. The link adaptation unit primarily bases its decisions on CQI feedback from the users in the cell. An outer loop link adaptation unit may also be applied to control the block error rate of first transmissions, based on, for example, HARQ acknowledgements (positive or negative) from past transmissions [7]. A similar outer loop link adaptation algorithm is widely used for HSDPA [8].

8.4.2 Frequency Domain Packet Scheduling

Frequency Domain Packet Scheduling (FDPS) is a powerful technique for improving the LTE system capacity. The basic principle of FDPS is illustrated in Figure 8.3. The FDPS principle exploits frequency selective power variations on either the desired signal (frequency selective fading) or the interference (fading or due to fractional other cell load) by only scheduling users on the PRBs with high channel quality, while avoiding the PRBs where a user experiences deep fades. A condition for achieving high FDPS gains is therefore that the radio channel's effective coherence bandwidth is less than the system bandwidth, which is typically the case for cellular macro and micro cell deployments with system bandwidths equal to or larger than 5 MHz.

As an example, Figure 8.4 shows the performance results from extensive macro cellular system level simulations versus the UE velocity. These results are obtained for a 10 MHz system

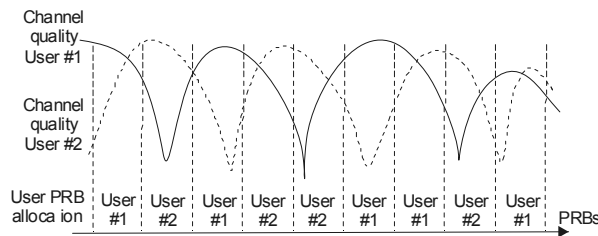

Figure 8.3 Frequency domain scheduling principle

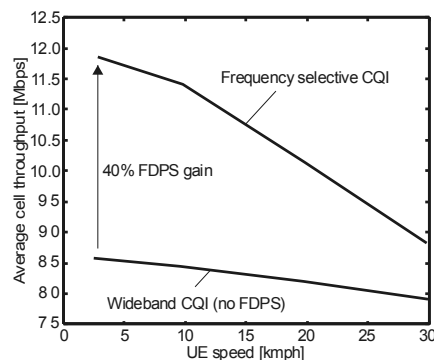

Figure 8.4 Capacity gain from Frequency Domain Packet Scheduling (FDPS)

bandwidth, a configuration with one transmit antenna and dual antenna UEs with interference rejection combining, Poisson arrival best effort traffic, and other assumptions in line with the 3GPP agreed simulation assumptions. The average cell throughput is reported. The results for simple wideband CQI correspond to cases with no FDPS, while the results with frequency selective CQI reporting are obtained with proportional FDPS. It is observed that a significant FDPS gain of approximately 40% is achievable for low to moderate UE speeds, while the FDPS gain decreases at higher UE speeds. The latter is observed because the radio channel cannot be tracked accurately due to the delay on uplink CQI reporting.

The time domain scheduling also can provide multi-user diversity gains when there is frequency flat fast fading. The gains depend on the amount of fading and on the speed of the fading. When there are deep fades, it gives more freedom for the scheduler to select optimally the user for the transmission. When the mobile speed is low enough, the scheduling is able to follow the fast fading. Therefore, the time domain scheduling gains generally get lower with:

- mobile antenna diversity since it reduces fading;
- base station transmit antenna diversity since it reduces fading;
- large bandwidth since it reduces fading due to frequency diversity;
- high mobile speed;
- multi-path propagation since it reduces fading due to multi-path diversity.

The time domain scheduling gains in LTE are relatively low since antenna diversity is a standard feature in the LTE terminal and also LTE uses typically large bandwidths.

Even though the spectral efficiency is maximized by operating with full frequency reuse [9], the system may start to operate in fractional load mode if there are only small data amounts in the eNodeB for the users in the cell. If such situations occur, the buffered data in the eNodeB are only transmitted on the required number of PRBs, while the rest of the PRBs are muted (i.e. no transmission). Under such fractional load conditions, the packet scheduler still aims at selecting the PRBs with the highest channel quality based on the CQI feedback. As illustrated in Figure 8.5 with a simple two-cell example, this allows convergence to a PRB allocation strategy between the two cells, where they aim at allocating complementary sets of PRBs to minimize the interference between the cells. As an example, it was shown in [10] that the average experienced Signal-to-Interference Noise Ratio (SINR) was improved by 10dB compared to the full load case by operating a 3-sector network at 25% fractional load by using CQI assisted scheduling. The 10dB improvement should be compared to the expected 6dB improvement from a 25% fractional load (i.e. factor of 4 reduced load corresponds to 6dB) with blind scheduling. The

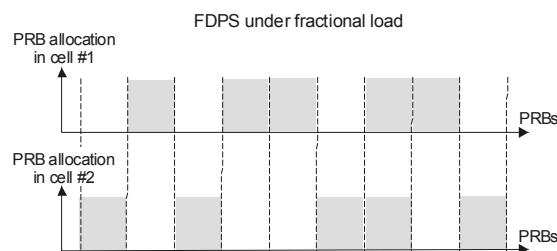

Figure 8.5 Frequency domain scheduling principle under fractional load conditions

CQI assisted scheduling scheme under fractional load resembles the well-known carrier sense allocation scheme from the Ethernet protocol. No explicit load information was shared over the X2 interface in this case.

8.4.3 Combined Time and Frequency Domain Scheduling Algorithms

Figure 8.6 illustrates the three-step packet scheduling implementation as proposed in [7]. The first step consists of the time-domain (TD) scheduling algorithm, which selects up to N users for potential scheduling during the next TTI. The time domain scheduler only selects users with (i) pending data for transmission and (ii) users configured for scheduling in the following TTI, i.e. excluding users in Discontinuous Reception (DRX) mode. The time domain scheduler assigns a priority metric for each of the N selected users. Secondly, a control channel schedule check is performed to evaluate if there is sufficient control channel capacity to schedule all the users selected by the time domain scheduler. This implies evaluating if there are enough transmission resources within the first 3 OFDM symbols to have reliable transmission of the PDCCH for each of the selected users. If the latter is not the case, then only a sub-set of the N users are passed to the frequency domain (FD) scheduler. In cases with control channel congestion, the users with the lowest priority metric from the time domain scheduler are blocked. Users with pending HARQ retransmissions can be given priority. Finally, the frequency domain scheduler decides how to schedule the remaining users across the available PRBs. Compared to a fully joint time/frequency domain packet scheduling method, this method provides similar performance at a much lower complexity as the frequency domain scheduler only has to consider a sub-set of the users for multiplexing on the PRBs.

Assuming that the number of users scheduled per TTI is smaller than the number of schedulable users per cell, the time domain scheduler becomes the primary instrument for QoS control, while the frequency domain scheduler task is to benefit from radio channel aware multi-user frequency diversity scheduling. This implies that the overall scheduling QoS concept from HSDPA (see e.g. [11] and [12]) can be generalized to also apply for the LTE time domain scheduler part for most cases. Thus, the barrier function based scheduler in [13], the QoS-aware schedulers with required activity detection in [14] and [15], and the generalized delay aware schedulers in [16] and [17] are all relevant for the LTE time domain scheduler. Similarly, the well-known proportional fair scheduler (as previously studied in [18] and [19], among others) can be extended for OFDMA based systems as discussed in [20], [21] and [22].

The frequency domain scheduler allocates PRBs to the users selected by the time domain scheduler. The overall objective is to allocate the available PRBs among the selected users to maximize the benefit from multi-user FDPS, while still guaranteeing a certain fairness. The frequency domain scheduler is responsible for allocating PRBs to users with new transmissions and also to users with pending HARQ retransmissions. Note, however, that it is not possible

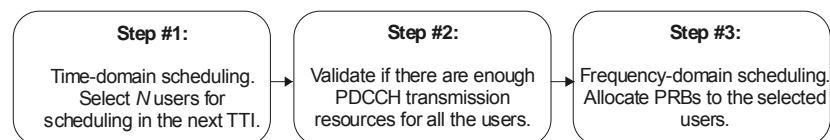

Figure 8.6 Illustration of the three-step packet scheduling algorithm framework

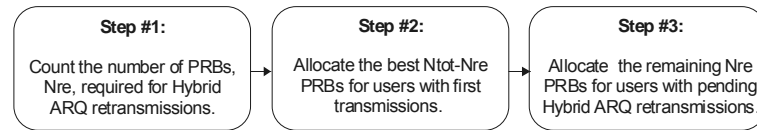

Figure 8.7 HARQ aware frequency domain packet scheduling

to simultaneously schedule new data and pending HARQ retransmissions to the same user in the same TTI. Pending HARQ retransmissions will typically be scheduled on the same number of PRBs as the original transmission. As scheduling of HARQ retransmissions creates a combining gain it is typically not critical to have those retransmissions allocated on the best PRBs. The latter argument has led to the proposed frequency domain scheduling framework summarized in Figure 8.7 [7]. In Step #1 the frequency domain scheduler computes the number of required PRBs (denoted by N_{re}) for scheduling of pending HARQ retransmissions for the selected users by the time domain scheduler. Assuming N_{tot} available PRBs for PDSCH transmission, users with new data are allocated the best $N_{tot}-N_{re}$ PRBs in Step #2. Finally, the remaining N_{re} PRBs are allocated for the users with pending HARQ retransmissions. This framework has the advantage that HARQ retransmissions are given priority (i.e. reducing HARQ delays) while maximizing the channel capacity by allocating the best PRBs for users with new data transmissions. The latter is an attractive solution for scenarios where the experienced channel quality is less critical for HARQ retransmissions due to the benefits from the HARQ combining gain. For highly coverage limited scenarios where it is important to maximize the channel quality for second transmissions, however, Steps #2 and #3 in Figure 8.7 can be exchanged. The exact algorithms for allocating PRBs to the considered users in Step #2 and Step #3 can be a simple diversity scheduler or a modified version of proportional fair or maximum throughput schedulers as discussed in [20], [7] and [22], among others. The full benefit from FPDS requires that the considered users are configured to report frequency selective CQI reports such as full sub-band reporting or average best-M (see more details in Chapter 5 for the CQI schemes).

8.4.4 Packet Scheduling with MIMO

Multi-antenna transmission, Multiple Input Multiple Output (MIMO) with two transmit and two receive antennas can use either one transport block or two independently coded transport blocks to the user on virtual streams on the allocated PRBs. The coded transport blocks are also called code-words. The transmission of two independently coded transport blocks requires that the Rank of the MIMO radio channel is at least two. In the latter case, the CQI feedback from the user will include information that allows the eNodeB link adaptation unit to potentially select different modulation and coding schemes for the two independent transport blocks. Separate acknowledgements are transmitted for each code-word such that link adaptation and HARQ for the two streams are decoupled. The eNodeB can dynamically switch between transmission of one and two code-words depending on the CQI and Rank Indicator feedback from the scheduled user. As a simple rule of thumb, the average SINR has to be in excess of approximately 12 dB before transmission of two independent transport blocks becomes attractive on a 2×2 MIMO link with Rank 2. From a packet scheduling point of view, the single-user MIMO

functionality is partially hidden as part of the link adaptation unit although supported TBS for the two streams is known by the packet scheduler. The different QoS-aware packet scheduling algorithms are equally applicable independent of whether advanced MIMO is being used or not. General discussions of MIMO schemes for OFDMA are available in [23].

LTE also supports multi-user MIMO transmission, where two users are scheduled on the exact same PRB(s), sending one independently coded transport block to each of the users by applying an appropriate set of antenna transmit weights. The two antenna transmission weights have to form orthogonal vectors while still being matched to achieve good received SINR for both users. To make multi-user MIMO attractive, i.e. maximizing the sum throughput served to the two users, the choice of the antenna transmission weights has to be accurate in both time and frequency domains. The latter also calls for coordinated packet scheduling actions, where users paired for transmission on the same PRB(s) are dynamically selected dependent on their joint short term radio channel characteristics. Hence, the usage of multi-user MIMO schemes also adds complexity to the packet scheduler and requires more control signaling (PDCCH).

8.4.5 Downlink Packet Scheduling Illustrations

This section presents performance results of LTE downlink packet scheduling. We first illustrate the impact of basic packet scheduling, mobile speed and antenna configuration on the cell and user throughput using a network emulation tool. Later in the section, we evaluate the QoS impact on the cell throughput and cell capacity by conducting dynamic system level simulations with multiple cells and multiple QoS UE classes.

Figure 8.8 and Figure 8.9 illustrate the impact of the packet scheduling, mobile speed and antenna configuration to the cell and user throughput. The plots are taken from an LTE network emulation tool. Figure 8.8 shows the cell throughput with proportional fair scheduler and with round robin scheduler with 3, 30 and 120km/h. The highest cell throughput is obtained with proportional fair scheduler at 3km/h. The throughput drops considerably when the mobile speed increases to 30km/h because the feedback is not able to follow the fast fading, and the frequency domain scheduling gain is lost. Increasing the mobile speed further to 120km/h has only a marginal impact on the capacity. The round robin scheduler has a lower cell throughput and less sensitivity to the mobile speed. There is some capacity increase with the round robin scheduler at 3km/h compared to 30 and 120km/h because the link adaptation works more

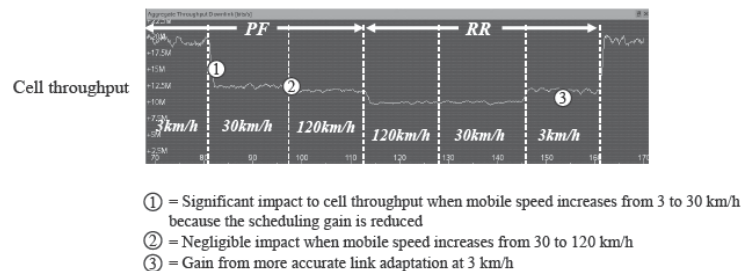

Figure 8.8 Example of downlink cell throughput with different schedulers and mobile speeds

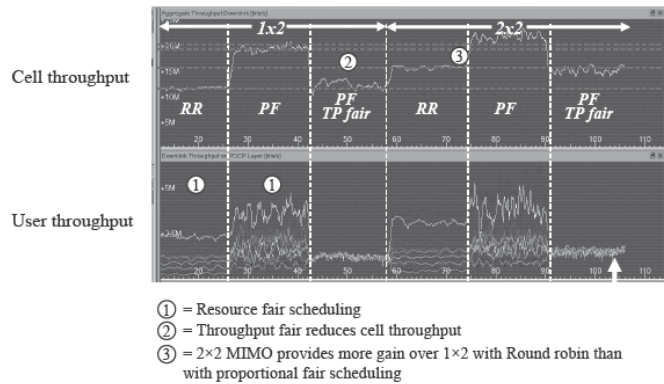

Figure 8.9 Example of downlink cell throughputs and user throughputs with different antenna configuration and different schedulers

accurately at 3 km/h. The capacity difference between proportional fair and round robin is small at 120 km/h, but increases at low mobile speeds.

Figure 8.9 shows the cell and user throughput with 1×2 antenna configuration (1 transmission branch at eNodeB and 2 receiver branches at UE) and with 2×2 MIMO at 3 km/h. Three different types of schedulers are presented: round robin, proportional fair with equal resource scheduling, and proportional fair with equal throughput. The proportional fair with equal resource scheduling increases both cell and user throughput with both antenna configurations. The relative gain from the proportional fair is higher with 1×2 since that antenna configuration has less diversity and experiences more fading than 2×2 MIMO. More fading gives more freedom for the scheduler to optimize the transmission. The throughput fair scheduling gives the same throughput for all users, but the cell throughput is clearly reduced compared to the resource fair scheduling. The cell edge users get higher throughput with throughput fair scheduling while those users in good locations get higher throughput with resource fair scheduling.

In the following we illustrate the design and the performance of a QoS-aware packet scheduler and the QoS impact on the cell throughput and cell capacity under full load. We consider the case of traffic mixes of best effort traffic (modeled as simple file download) with no QoS constraints and constant bit rate (CBR) applications with strict GBR QoS constraints. The results presented in the following are obtained with 1×2 interference rejection combining (IRC) antennas, for a system bandwidth of 10 MHz and for localized transmission.

The time domain (TD) packet scheduler is the primary entity to facilitate QoS differentiation, in terms of both service and user differentiation. An example of a QoS-aware packet scheduler is introduced in Table 8.2. The proposed scheduler is limited here to GBR-awareness for simplicity. It uses a GBR-aware time domain metric based on a modified version of the proportional fair scheduler with adjustment according to the estimated required activity level for a certain user. Such a Required Activity Detection (RAD) scheduler dynamically estimates the capacity used by serving the GBR users and it is able to share the remaining part, often called the excess capacity, according to any desired policy, e.g. by setting QoS class-specific shares. The frequency domain scheduler is based on a modification of the proportional fair metric, called proportional fair scheduler (PFsch). Similarly to the time domain proportional fair scheduler,

Table 8.2 Example of QoS-aware packet scheduler in LTE

Scheduler	Time domain scheduling metric, M_n	Frequency domain scheduling metric, $M_{n,k}$
(TD) QoS PS	Required Activity Detection (RAD) [14], [15]	Proportional Fair scheduled (PFsch) [21]
	$\frac{D_n}{R_n} \cdot \left(\frac{GBR_n}{R_{sch,n}} + Share_n \cdot ExcessCap \right)$	$\frac{d_{n,k}}{R_{sch,n}}$

D_n = Instantaneous wideband achievable throughput for user n .
 \bar{R}_n = Past average throughput of user n .
 $d_{n,k}$ = Instantaneous achievable throughput for user n on PRB k .
 $\bar{R}_{sch,n}^{k}$ = Past average throughput over the TTIs where user n is selected by the TD scheduler.
 GBR_n = Guaranteed bit rate of user n .
 $ExcessCap$ = Excess capacity (i.e. capacity left after minimum QoS is fulfilled).
 $Share_n$ = Share of the excess capacity of user n .

the PFsch scheduler is designed to opportunistically benefit from radio channel aware multi-user frequency diversity and it aims at maximizing the spectral efficiency while providing resource fairness among the users. This scheduler decouples the behavior of the frequency domain scheduler from the time domain scheduler decisions, and vice versa [21]. In fact, the time–frequency domain coupling occurs whenever the time and the frequency domain metrics perform the allocation of the activity and the frequency resources based on the same feedback, e.g. the past average throughput. The coupling may lead to conflicting decisions when users are assigned a high activity rate but a low share of frequency resources, or vice versa.

Figure 8.10 shows the performance of the QoS packet scheduler as described in Table 8.2. The environment is 3GPP macro cell case #1. The results are obtained assuming different traf-

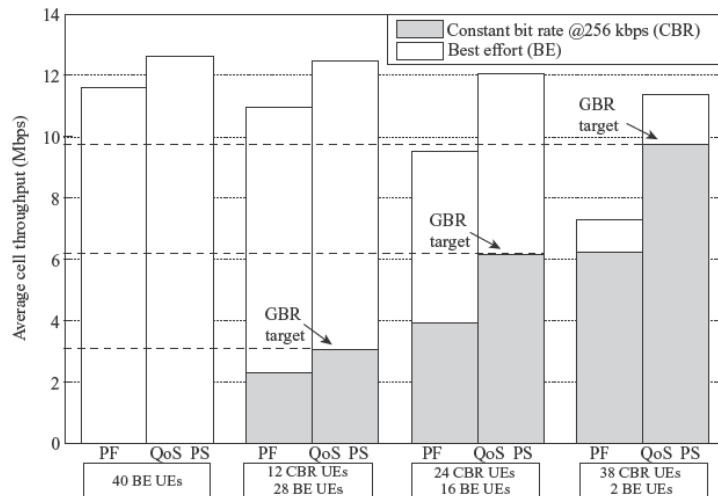

Figure 8.10 Average cell throughput for different traffic mixes of best effort and CBR traffic, for proportional fair scheduler and QoS-aware packet scheduler (see Table 8.2)

fic mixes of best effort traffic and constant bit rate (CBR) applications with strict GBR QoS constraints of 256 kbps. As reference, results with the time/frequency domain proportional fair scheduler are also depicted. As expected, the proportional fair scheduler is not able to meet the GBR demands of a large percentage of CBR users as some users do not have sufficient performance with the proportional fair even-resource allocation principle. The figure illustrates that the QoS-aware scheduler strictly provides QoS to 100% of the CBR users and it has the ability to distribute the excess capacity among the best effort users. It is also observed that the average cell throughput with only best effort traffic decreases when more CBR users are present in the cell as shown with 12, 24 and 38 CBR users per cell, respectively, over the total of 40 users. The latter is observed because the CBR users are strictly served with their GBR requirement regardless of their location in the cell, hence reducing the freedom for the packet scheduler to optimize the cell throughput.

To tackle the need for supporting high GBRs compared to the cell throughput, the QoS aware time domain scheduler alone is not sufficient. To fully understand this limitation one should consider that, with a certain FDPS policy, a CBR user may not be capable of meeting its GBR requirement from a link budget perspective by only being assigned the maximum activity (i.e. the time domain scheduler selects the user every TTI). Note that the highest supportable GBR depends on the system bandwidth, the environment, the frequency domain packet scheduler, and the number of UEs multiplexed per TTI. Therefore, to support high GBR, QoS awareness is required to be further included in the frequency domain scheduler. An example of an adjustment to be applied to the frequency domain metric of GBR users is the following weight factor:

$$w_{FD,n} = \frac{GBR_n}{\bar{R}_{schPerPRB,n}} \quad (8.1)$$

where $\bar{R}_{schPerPRB,n}$ is the past average throughput per PRB over the TTIs where user n is allocated PRB resources. The adjustment estimates the share of frequency resources required by a GBR user to meet the GBR requirement, and it aims at allocating a higher share, when needed. For the sake of simplification, details are omitted on the weight lower bound and on the normalization of the non-GBR frequency domain metrics needed to account for the constraint of a limited number of frequency resources.

Figure 8.11 illustrates the performance of the QoS PS scheduler (see Table 8.2) with a mix of 12 best effort users with no QoS and 8 CBR users with strict GBR QoS constraints increasing from 512 kbps, to 768 kbps and up to 1024 kbps. It can be observed that the QoS differentiation uniquely enforced by QoS aware time domain is not sufficient for supporting 100% of the CBR traffic when GBR equals 768 and 1024 kbps. When applying the frequency domain weight, w_{FD} , results show that a strict provision of the GBR requirements for all the CBR users is ensured with a limited cost in decreased FDPS gain.

8.5 Uplink Dynamic Scheduling and Link Adaptation

There are a few differences between uplink and downlink packet schedulers. The main differences are listed below.

- 1 eNodeB does not have full knowledge of the amount of buffered data at the UE. See section 8.5.1.2 for details on buffer status reports.

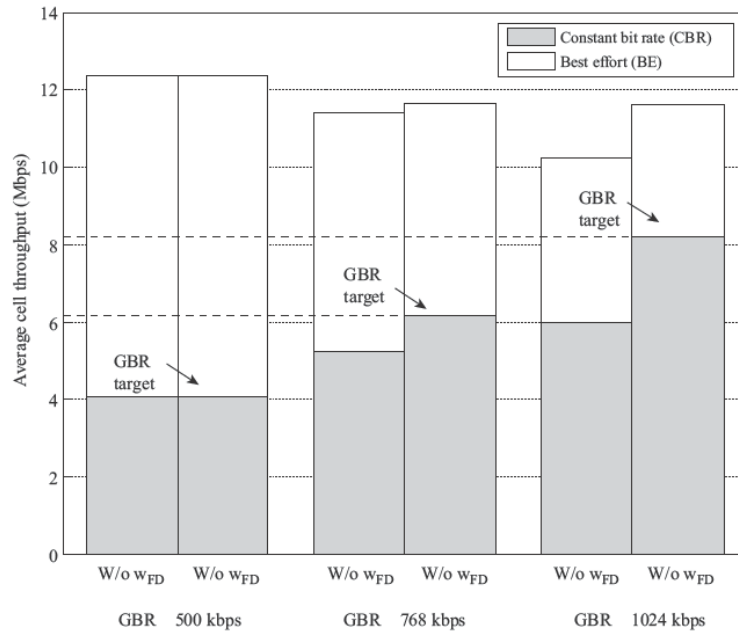

Figure 8.11 Average cell throughput for a traffic mix of 12 best effort and 8 CBR users per cell, when GBR equals 512, 768 and 1024 kbps. Results are obtained with the QoS aware packet scheduler as in Table 8.2, with and without the QoS-aware frequency domain weight

- 2 The uplink direction is more likely going to be power limited than the downlink due to low UE power compared to eNodeB. This means that especially in macro cell deployments users cannot always be allocated a high transmission bandwidth to compensate for poor SINR conditions.
- 3 Only adjacent physical resource blocks can be allocated to one user in uplink due to single carrier FDMA transmission. The fundamental difference between PRB allocation in LTE downlink and uplink stems from the uplink channel design and is illustrated with an example in Figure 8.12. The single-carrier constraint in LTE uplink limits both frequency and multi-user diversity.
- 4 The uplink is typically characterized by high interference variability [24] [25]. Interference variations from TTI to TTI in the order of 15–20 dB make it a hard task to estimate accurately the instantaneous uplink interference. Therefore in LTE uplink fast adaptive modulation and coding and channel-aware FDPS is typically based on channel state information about the own desired signal path rather than on the instantaneous interference level.
- 5 An uplink grant transmitted on PDCCH in TTI n refers to uplink transmission in TTI $n+4$. This 4 ms delay is due to PDCCH decoding and processing time at the UE and represents a further limitation to link adaptation and channel-aware packet scheduling in uplink. For more details, please refer to the PDCCH physical layer description in Chapter 5.

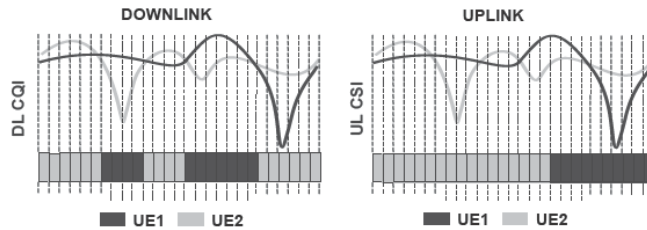

Figure 8.12 Example illustrating the single-carrier constraint to frequency domain packet scheduling in uplink

An overview of the uplink RRM functionalities and their interaction is given in Figure 8.13. As for the downlink, both uplink fast adaptive modulation and coding and frequency domain packet scheduler rely on frequency-selective channel state information (CSI). Uplink channel state information is estimated based on the SRS transmitted by the UE. The core of the uplink RRM functionality is the interaction between the packet scheduler, including fast Adaptive Transmission Bandwidth (ATB), and the so-called Link Adaptation (LA) unit, including Power Control (PC), adaptive modulation and coding and Outer-Loop Link Adaptation (OLLA). Buffer status reports and scheduling requests are also part of the core input to the uplink scheduler.

Interaction between the uplink dynamic packet scheduler and adaptive modulation and coding – The adaptive modulation and coding function is responsible for providing information to the packet scheduler on the channel state of a certain user in correspondence of a specific

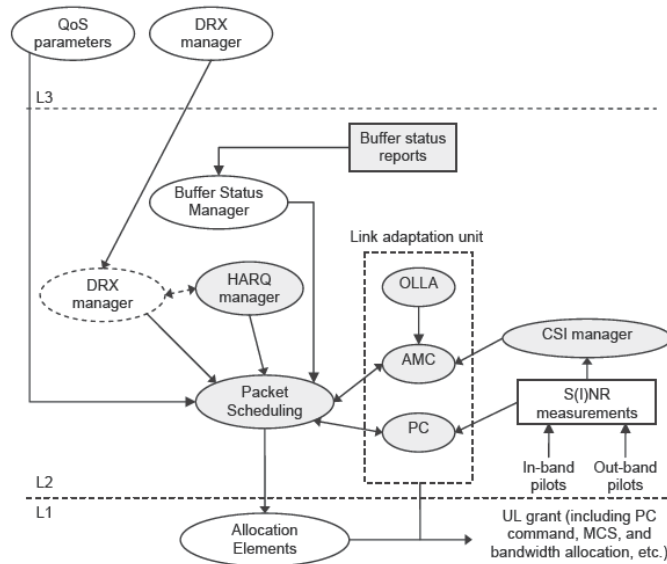

Figure 8.13 Inter-working between packet scheduling, link adaptation unit, and other uplink RRM functionalities

transmission bandwidth. In this sense the adaptive modulation and coding function is the link between the uplink packet scheduler and the uplink channel state information manager, which collects uplink channel state information based on the transmission of SRS in the uplink. Fast adaptive modulation and coding is also responsible for selecting the most appropriate MCS once the uplink packet scheduler has allocated a specific uplink band to the corresponding UE.

Interaction between packet scheduler and power control – The main scope of power control in LTE uplink is to limit inter-cell interference while respecting minimum SINR requirements based on QoS constraints, cell load and UE power capabilities. The uplink transmission power is set in the UE based on the following standardized formula [26]:

$$P_{\text{PUSCH}} = \min \{ P_{\text{MAX}}, 10 \log_{10} (M_{\text{PUSCH}}) + P_{\text{O_PUSCH}} + \alpha \cdot PL + \Delta_{\text{MCS}} + f(\Delta_i) \} \text{ [dBm]} \quad (8.2)$$

where P_{MAX} is the maximum allowed power and depends on the UE power class, M_{PUSCH} is the number of allocated PRBs on the Physical Uplink Shared Channel (PUSCH), PL is the downlink path loss measured by the UE (including distance-dependent path loss, shadowing and antenna gain), $P_{\text{O_PUSCH}}$, α and Δ_{MCS} are power control parameters, and $f(\Delta_i)$ is the closed loop power control correction transmitted by the eNodeB [26].

Figure 8.14 [27] is obtained assuming $\Delta_{\text{MCS}} = 0$ and $f(\Delta_i) = 0$ in equation (8.1), and clearly illustrates how the distribution of uplink SINR – and hence the system performance – strongly depends on the power control parameters, as well as on the propagation scenario. In general power control in uplink determines the average SINR region a user is operated at, which is similar to the G-factor in downlink. Since the UE performs power scaling depending on the allocated transmission bandwidth, the packet scheduler needs to have information on the UE transmit power spectral density so that the allocated transmission bandwidth does not cause the UE power capabilities to be exceeded. For such use, power headroom reports have been standardized for LTE uplink; see section 8.5.3.1 for more details.

Interaction between outer loop link adaptation and adaptive modulation and coding – As already pointed out, the adaptive modulation and coding functionality is responsible for two main tasks: (i) providing the link between the packet scheduler and the channel state informa-

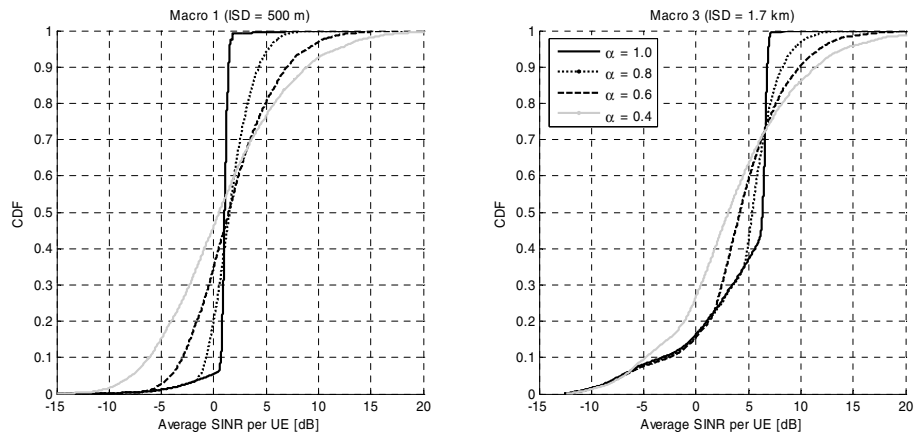

Figure 8.14 CDF of the average SINR per user for different propagation scenarios and values [27]

tion manager, and (ii) selecting the most appropriate MCS to be used for transmission on the selected uplink band by the uplink packet scheduler. In order to fulfill these tasks the adaptive modulation and coding functionality needs to map channel state information from the channel state information manager into SINR and/or MCS. This function is similar to downlink; the main goal of OLLA is to compensate for systematic errors in the channel state information at the output of the channel state information manager so that packet scheduler and adaptive modulation and coding can perform correctly.

8.5.1 Signaling to Support Uplink Link Adaptation and Packet Scheduling

Fast link adaptation and channel-aware scheduling in LTE uplink strongly relies on the availability of frequency-selective channel state information based on SRS measurements. Moreover, since the uplink transmission buffers are located in the UE, the information on the buffer status needs to be transmitted in the uplink as well. Also, the user needs to report power headroom measurements in order to signal to the uplink packet scheduler (and to the fast ATB functionality in particular) how close it is operating to its maximum power capabilities. While the SRS physical layer details are covered in Chapter 5, in the following section RRM aspects of the LTE uplink channel sounding concept are briefly discussed. Next, the transmission of the so-called uplink scheduling information (i.e. buffer status and power headroom reports) is also addressed.

8.5.1.1 Sounding Reference Signals (SRS)

The uplink sounding concept basically determines ‘when and how’ an uplink SRS is transmitted. As a consequence, the sounding concept and parameters have a significant impact on the accuracy of uplink SRS measurements, and hence on the performance of uplink link adaptation and packet scheduling. From an uplink RRM perspective, some of the most important sounding parameters are [28]:

- SRS bandwidth: Indicates the transmission bandwidth of the uplink SRS. The SRS bandwidth is semi-statically signaled via RRC.
- SRS period and time offset: Indicates System Frame Number (SFN) modulo number and periodicity of SRS from one UE. The SRS period and time offset are semi-statically signaled via RRC. 3GPP has also standardized the possibility for the eNodeB to disable SRS transmission on a per-UE basis.
- SRS duration: Indicates for how long a UE must keep on transmitting the uplink SRS. SRS duration is also semi-statically signaled via RRC.
- Transmission combination, Constant Amplitude Zero Autocorrelation (CAZAC) sequence index and cyclic shift: Necessary to guarantee orthogonality among users transmitting uplink SRS using the same transmission bandwidth (see more details in Chapter 5). In LTE uplink up to 6 UEs/cell can share the same SRS bandwidth without interfering with each other.
- SRS sub-band hopping sequence: Determines the hopping sequence in case, for example, the SRS bandwidth is much narrower than the available bandwidth for scheduling.

It is an uplink RRM task to distribute the limited SRS resources among active users so that accurate and up-to-date channel state information is available. For instance, typically there is a

tradeoff between measurement accuracy and SRS bandwidth (especially for power limited users): The narrower the SRS bandwidth, the higher the measurement accuracy [29]. On the other hand, several narrowband SRS transmissions are required to sound the entire schedulable bandwidth. Therefore, channel state information can become relatively outdated if the SRS periodicity and sub-band hopping are not configured properly. Another task of the uplink RRM functionality is to decide which users should be transmitting SRSs using the same time and frequency resources, since their orthogonality strongly depends on the received power level from the different UEs.

8.5.1.2 Buffer Status Reports (BSR)

The buffer status information is reported in uplink to inform the uplink packet scheduler about the amount of buffered data at the UE. LTE introduces a buffer status reporting mechanism that allows distinguishing between data with different scheduling priorities. The LTE buffer status reporting mechanism basically consists of two phases: (i) Triggering and (ii) Reporting.

Triggering

A Buffer Status Report (BSR) is triggered if any of the following events occur [30]:

- Uplink data arrive in the UE transmission buffer and the data belong to a radio bearer (logical channel) group with higher priority than those for which data already existed in the UE transmission buffer. This also covers the case of new data arriving in an empty buffer. The Buffer Status Report is referred to as ‘regular BSR’.
- Uplink resources are allocated and number of padding bits is larger than the size of the BSR MAC control element, in which case the Buffer Status Report is referred to as ‘padding BSR’ (see below).
- A serving cell change occurs, in which case the Buffer Status Report is referred to as ‘regular BSR’ (see below).
- The periodic BSR timer expires, in which case the BSR is referred to as ‘periodic BSR’ (see below).

Reporting

The main uplink buffer status reporting mechanisms in LTE are the Scheduling Request (SR) and the Buffer Status Report (BSR) [30].

Scheduling request (SR): The SR is typically used to request PUSCH resources and is transmitted when a reporting event has been triggered and the UE is not scheduled on PUSCH in the current TTI. The SR can be conveyed to the eNodeB in two ways:

- Using a dedicated ‘one-bit’ BSR on the Physical Uplink Control Channel (PUCCH), when available. The occurrence of SR resources on PUCCH is configured via RRC on a per UE basis. It might be possible that no resources for SR are allocated on PUCCH.
- Using the Random Access procedure. Random Access is used when neither PUSCH allocation nor SR resources are available on PUCCH.

According to the 3GPP specifications [30], a SR is only transmitted as a consequence of the triggering of a ‘regular BSR’. The triggering of ‘periodic BSR’ and ‘padding BSR’ does not cause the transmission of a SR.

Buffer status report (BSR): BSRs are transmitted using a Medium Access Control (MAC) control element when the UE is allocated resources on PUSCH in the current TTI and a reporting event has been triggered. Basically the buffer status report is transmitted as a MAC-C PDU with only header, where the field length is omitted and replaced with buffer status information [30].

In summary, when a reporting event is triggered:

- If the UE has resources allocated on PUSCH, then a buffer status report is transmitted.
- If a 'regular BSR' is triggered and the UE has no PUSCH allocation in the current TTI but has SR resources allocated on PUCCH, then a SR is transmitted on PUCCH at the first opportunity.
- If a 'regular BSR' is triggered and the UE has neither SR resources allocated on PUCCH nor PUSCH allocation, then a SR is issued using the Random Access Procedure.

The design of buffer status reporting schemes and formats for UTRAN LTE uplink has been driven by two important factors [6]:

- Separate buffer status reports for data flows with different QoS characteristics/requirements are needed to support QoS-aware radio resource allocation.
- The overhead from the BSR needs to be minimized since it directly affects the uplink capacity.

Therefore within 3GPP it has been agreed that buffer status is reported on a per Radio Bearer Group (RBG) basis. A RBG is defined as a group of radio bearers with similar QoS requirements. The maximum number of radio bearer groups, however, has been fixed and is four. An example showing the mapping from radio bearers to RBG for buffer status reporting is shown in Figure 8.15.

Two BSR formats are used in LTE uplink [30]: Short BSR (only one radio bearer group is reported) and long BSR (all four radio bearer groups are reported). In the first case 2 bits are required for radio bearer group identification, while in the latter case the 4 buffer size fields can be concatenated. In any case, the buffer size fields of the BSR are 6 bits long.

The basic idea is to transmit a short BSR if there are only data from one radio bearer group in the UE buffer, otherwise always transmit a long BSR. Some exceptions have been included in the standard in order to take into account the cases where, for example, a short BSR fits in the allocated transport block size, but a long BSR does not (see [30] for more details).

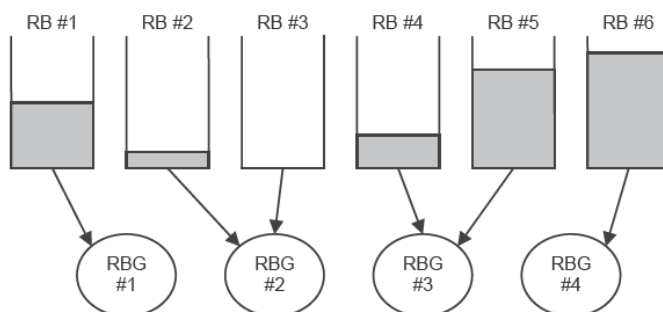

Figure 8.15 Example of mapping from RB to radio bearer group for buffer status reporting

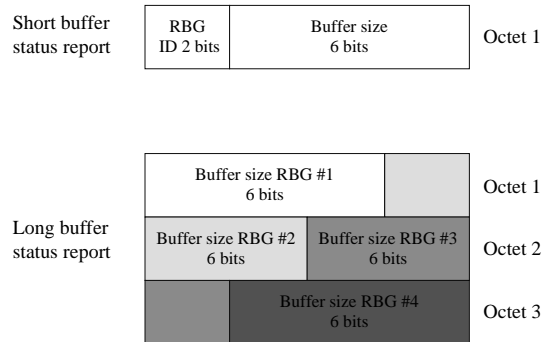

Figure 8.16 Short and long buffer status report types in LTE uplink [30]

8.5.1.3 Power Headroom Reports

Due to the open loop component in the standardized power control formula (see Chapter 5) the eNodeB cannot always know the power spectral density level used at the UE. Information on the power spectral density is important for performing correct RRM decisions at the eNodeB, especially when allocating the transmission format including bandwidth and modulation and coding scheme. Not knowing the power spectral density used by a certain terminal could, for example, cause the allocation of a too high transmission bandwidth compared to the maximum UE power capabilities, thus resulting in a lower SINR than expected. Information on the power spectral density used at the UE can be obtained from power headroom reports, provided that the eNodeB knows the corresponding transmission bandwidth. Information on the power spectral density is primarily critical for the PUSCH as the transmission format for this channel is adaptively adjusted. For all these reasons power headroom reports have been standardized in 3GPP. The power headroom is calculated at the UE as the difference between the maximum UE transmit power and the 'nominal' PUSCH transmit power in the corresponding subframe set according to the PUSCH power control formula in [26]. A power headroom report is triggered if any of the following criteria are met [30]:

- An appositely defined prohibit timer expires or has expired and the path loss has changed by more than a pre-defined threshold since the last power headroom report. The prohibit timer is introduced to limit unnecessarily frequent transmissions of power headroom reports.
- An appositely defined periodic timer expires.

More details on the triggering and transmission of power headroom reports can be found in [30].

8.5.2 Uplink Link Adaptation

Uplink link adaptation strongly relies on uplink SRS measurements. The uplink sounding concept and parameters basically determine how often and on which uplink physical resources the SRS measurements are available for a given UE, the measurement accuracy, etc. Then, similarly

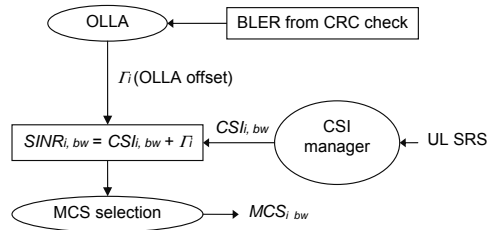

Figure 8.17 Schematic of the uplink fast adaptive modulation and coding functionality

to downlink CQI, uplink SRS measurements are used by the channel state information manager to determine the most appropriate MCS for transmission on a specific uplink bandwidth. Also, uplink SRS measurements can be used by the uplink frequency domain scheduler when, for example, computing the scheduling priority of a specific user in correspondence of a specific uplink band. The uplink link adaptation functionality based on fast adaptive modulation and coding is schematically illustrated in Figure 8.17.

Uplink SRS measurements are eNodeB vendor specific and as a consequence are not strictly specified by 3GPP. However, it has been shown that uplink fast adaptive modulation and coding based on instantaneous SINR measurements can suffer from uplink interference variability [24]. On the other hand, selecting the MCS based on instantaneous channel conditions can still give a significant gain compared to slow AMC schemes [25]. Therefore one feasible implementation is to use uplink SRS to perform frequency-selective signal strength measurements with the aim of tracking fast fading on the signal component, while interference can be treated as a constant in order to minimize the effect of interference unpredictability.

8.5.3 Uplink Packet Scheduling

The main responsibility of the uplink packet scheduler is to share the available radio resources between users taking into account limitations and/or requirements imposed by other RRM functionalities.

- Packet scheduler and DRX/DTX. Users cannot be scheduled for transmission on PUSCH unless they are listening to the L1/L2 control channel.
- Packet scheduler and power control. UE transmission power capabilities must be considered when, for example, packet scheduler (ATB) allocates the uplink transmission bandwidth to a specific UE.
- Packet scheduler and QoS. The packet scheduler is responsible for fulfilling the user QoS requirements.
- Packet scheduler and BSRs. Users should be scheduled for data transmission only if they have data to transmit. Also, the prioritization between users can be carried out based on the information conveyed by BSRs (e.g. users with high priority data are prioritized over users with low priority data).
- Packet scheduler and HARQ. Synchronous HARQ is used for LTE uplink. Hence, the UE must be scheduled if an earlier transmission has failed.
- Packet scheduler and MIMO. Uplink multi-user (MU-) MIMO can be used in Release 8 of the 3GPP specifications. With MU-MIMO the uplink packet scheduler can simultane-

ously allocate the same frequency resources to two users. The orthogonality between users is achieved by exploiting frequency-domain channel state information available via SRS measurements. No specific signaling (neither downlink nor uplink) is needed to support MU-MIMO in uplink.

As for the downlink (see Figure 8.6), the uplink packet scheduler is split in two sub-units: one that works in the time domain (TD) and one that works in the frequency domain (FD). The time domain metric is typically computed based on the experienced QoS vs QoS requirements and the estimated buffer occupancy. The channel-aware time domain scheduling metrics only take into account wideband channel state information. Basically, the time domain scheduler for uplink and downlink follows the same principle. The only difference is that the time domain scheduler in uplink must always prioritize users with pending retransmissions independently of other users' priority, QoS and channel conditions due to the uplink synchronous HARQ.

The allocation in the frequency domain is performed based on specific frequency domain scheduling metrics, which are typically computed based on frequency selective channel state information available from SRS measurements. QoS requirements and BSRs can also be considered when deriving frequency domain scheduling metrics. The main difference between uplink and downlink frequency domain PS is that in uplink the FDPS algorithm has to deal with the restrictions imposed by single-carrier transmission and limited UE power capabilities.

8.5.3.1 Example of Frequency Domain Packet Scheduler with Fast Adaptive Transmission Bandwidth

LTE supports fast Adaptive Transmission Bandwidth (ATB) in the uplink, i.e. the user transmission bandwidth can be modified on a TTI basis depending on channel conditions, traffic, fulfillment of QoS requirements, etc. With fast ATB the allocation of the user transmission bandwidth can be integrated in the FDPS algorithm. In this way, for instance, QoS-aware schedulers can be implemented in combination with channel-aware scheduling by simply introducing a QoS-based metric per UE depending on the level of fulfillment of its QoS requirements. In the time domain, users are ordered based on such a QoS-based metric, while in the frequency domain the frequency selective scheduling metric can potentially be weighted by the QoS-based metric. In this way fast ATB can guarantee automatic adaptation to variations in the cell load by, for example, differentiating resource allocation between different QoS users in the time or frequency domain depending on the temporary cell load.

Assuming that frequency-selective uplink channel state information is available at the uplink packet scheduler based on uplink SRS measurements (see section 8.5.1), a scheduling metric per user per PRB can then be defined based on uplink channel state information as well as on fulfillment of QoS requirements, buffers status information, etc. An example of a FDPS algorithm, which is illustrated in Figure 8.18, starts allocating the user with the highest scheduling metric on the corresponding PRB. The user is then 'expanded' respecting the single-carrier transmission constraint of the LTE uplink until another user with a higher metric is met, or the UE transmission power constraints are exceeded (known via power headroom information reported by the UE), or the UE has no more data to transmit (known via buffer status information reported by the UE). Then a similar procedure is repeated until the entire bandwidth is used or there are no more users to schedule.

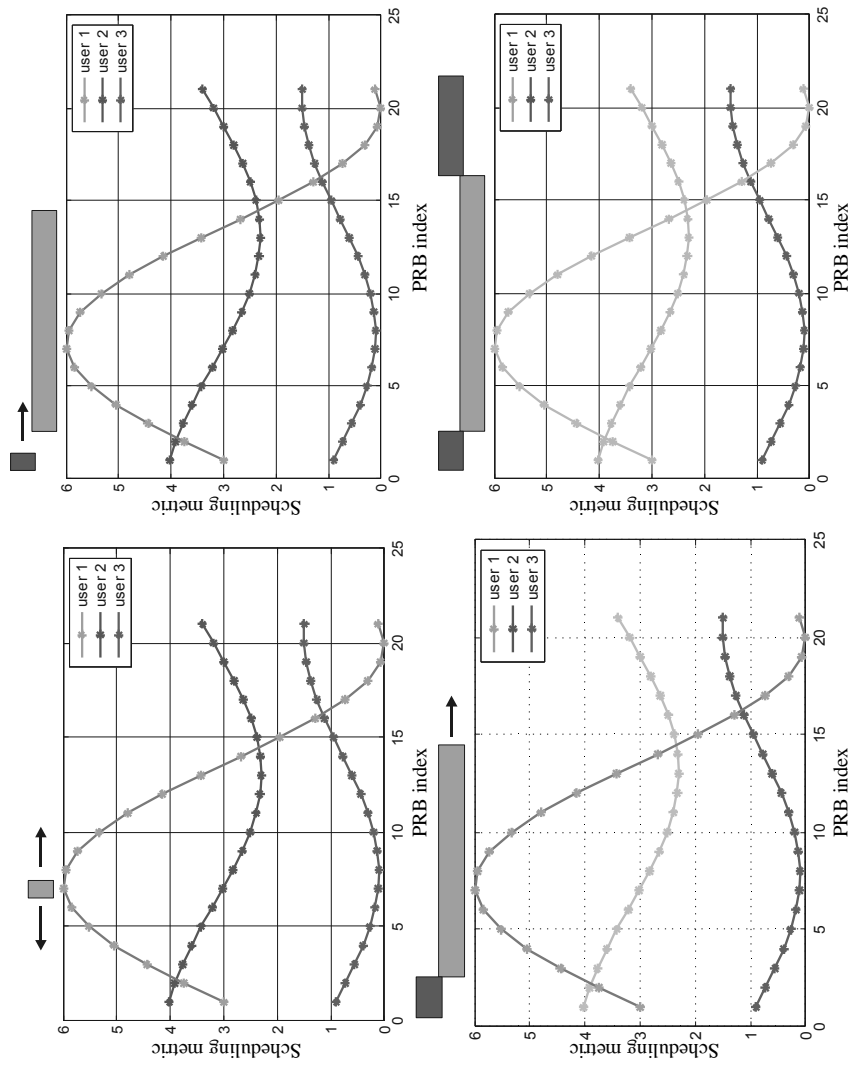

Figure 8.18 Example of combined fast adaptive transmission bandwidth and frequency domain packet scheduling algorithm in LTE uplink

The fast ATB framework described in this example is able to achieve most of the gain compared to more complex FDPS algorithms, which try to derive near-optimum FDPS solutions using more exhaustive approaches [31] [32]. Due to its iterative nature the complexity of the algorithm remains very high, however, unless the time domain framework effectively limits the scheduling order of the system. Because of this, many simulations that have been conducted during the 3GPP work item phase have been based on the assumption of fixed bandwidth uplink packet scheduling [33].

Figure 8.19 and Figure 8.20 show some examples of gain numbers of uplink FDPS (proportional fair) compared to blind scheduling in the frequency domain.

In general higher gain numbers can be observed when the capacity is measured with user throughput outage criteria. The reason is that the SINR gain from proportional fair scheduling typically maps into a higher throughput gain in the lower SINR regions. Also, note that for a given user transmission bandwidth, the cell throughput gain from frequency domain scheduling tends to saturate 15 simultaneous users.

By reducing the user transmission bandwidth the gain from frequency domain scheduling increases (see Figure 8.20). Due to the single-carrier constraint, however, a high number of users needs to be scheduled each TTI to fully exploit the frequency selectivity of the channel. In practice due to PDCCH limitations approximately 8–10 users can be scheduled in uplink each TTI, which means that the user transmission bandwidth is about 5–6 PRBs. Therefore while the potential gain from uplink frequency scheduling is about 40% in average cell throughput and 85% in outage user throughput, single-carrier constraint and practical PDCCH implementation limit the actually achievable gain to 25% and 50%, respectively.

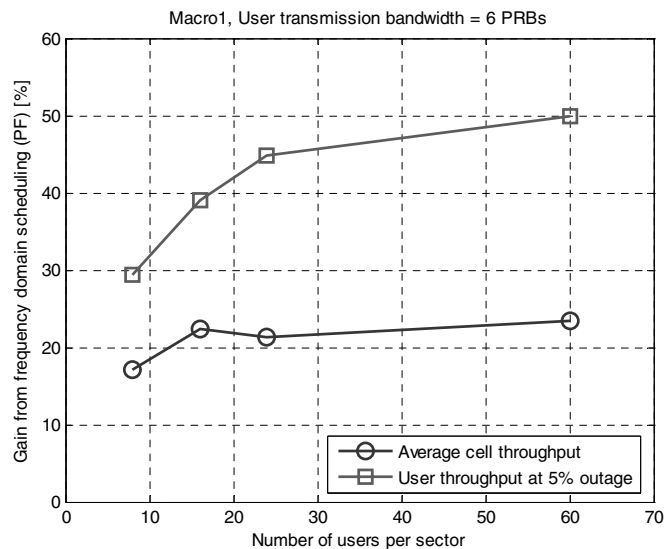

Figure 8.19 Gain from uplink frequency domain scheduling as a function of number of users for Macro 1 scenario and a fixed user transmission bandwidth of 6 PRBs

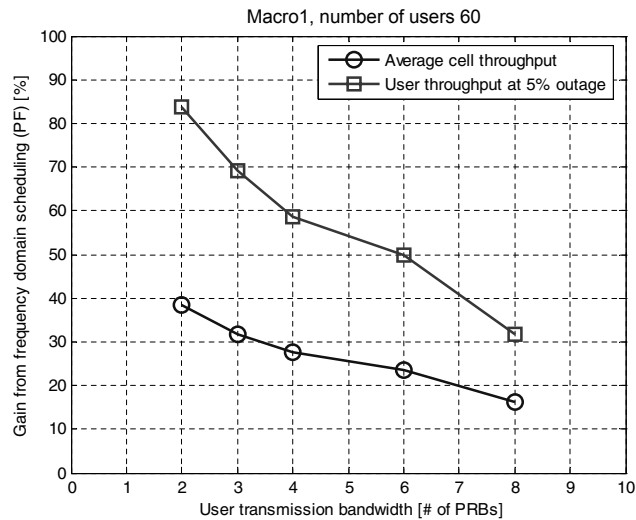

Figure 8.20 Gain from uplink frequency domain scheduling as a function of the user transmission bandwidth for Macro 1 propagation scenario and 60 simultaneous users

8.6 Interference Management and Power Settings

LTE includes a variety of mechanisms for controlling the interference between neighboring cells, also known as inter-cell interference control (ICIC). The standardized ICIC schemes for Release 8 primarily rely on frequency domain sharing between cells and adjustment of transmit powers. The X2 interface between eNodeBs includes standardized signaling for carrying interference information and scheduling information. The standardized ICIC methods are categorized as follows:

- **Reactive schemes:** Methods based on measurements of the past. Measurements are used to monitor the performance, and if the interference detected is too high, then appropriate actions are taken to reduce the interference to an acceptable level. Actions could include transmit power adjustments or packet scheduling actions to reduce the interference coupling between cells.
- **Proactive schemes:** Here an eNodeB informs its neighboring eNodeBs how it plans to schedule its users in the future (i.e. sending announcements), so that the neighboring eNodeB can take this information into account. Proactive schemes are supported via standardized signaling between eNodeBs over the X2 interface, e.g. by having eNodeBs sending frequency domain scheduling announcements to their neighbors.

3GPP Release 8 ICIC schemes are primarily designed for improving the performance of the uplink and downlink shared data channel (PDSCH and PUSCH). Hence, no explicit ICIC techniques are standardized for common channels like the BCCH, and control channels such as PDCCH and PUCCH (except for the use of power control). Note that for Release 8 time-synchronized networks (frame synchronized), the PDCCH and PUCCH always send at the same time and frequency.

8.6.1 Downlink Transmit Power Settings

Proactive downlink ICIC schemes are facilitated via the standardized Relative Narrowband Transmit Power (RNTP) indicator. The RNTP is an indicator (not a measurement) per PRB signaled to neighboring eNodeBs over the X2 interface. It indicates the maximum anticipated downlink transmit power level per PRB. Hence, from this information the neighboring eNodeBs will know at which PRBs a cell plans to use the most power, and the idea is thus that different power patterns can be used in those cells to improve the overall SINR conditions for the UEs. It is implementation specific how often a new RNTP indicator is sent from an eNodeB, and also the exact actions by an eNodeB receiving such messages are left unspecified by 3GPP.

By setting different downlink transmit powers per PRB, it is possible to dynamically configure different re-use patterns ranging from full frequency re-use (re-use one) with equal transmit power on all PRBs, to hard frequency re-use as shown in Figure 8.21, fractional frequency re-use as pictured in Figure 8.22, and soft frequency re-use as illustrated in Figure 8.23. The basic idea for fractional frequency re-use is that users close to their eNodeB are scheduled in the frequency band with frequency re-use one, while the cell-edge users are scheduled in the complementary frequency band with, for example, hard frequency re-use three in Figure 8.21. When using the soft frequency re-use configuration in Figure 8.23, users are scheduled over the entire bandwidth with different power levels. Cell-edge users are primarily scheduled in the bandwidth with the highest power level, while users closer to their serving eNodeB are scheduled on the PRBs with lower transmit power. Note that PRBs allocated to the same user should be transmitted with the same power level. Further information about performance results for different downlink transmit power profiles is presented in [9].

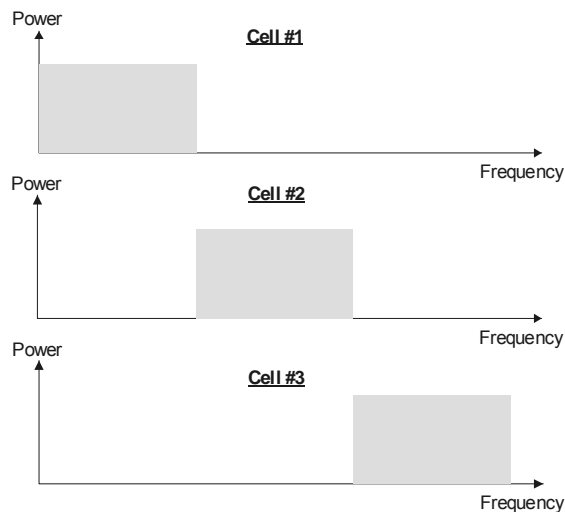

Figure 8.21 Example of downlink transmit power settings for hard frequency re-use three

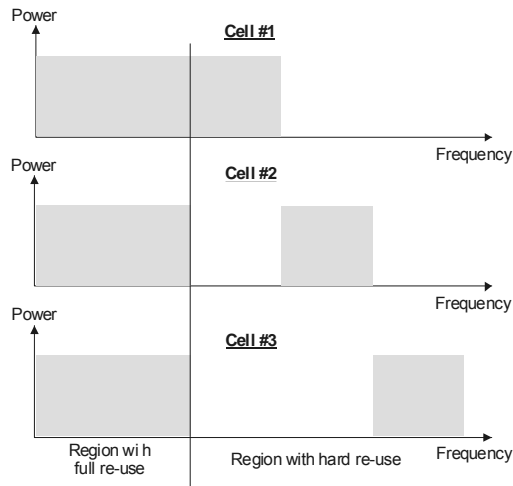

Figure 8.22 Example of downlink transmit power settings for a fractional frequency re-use

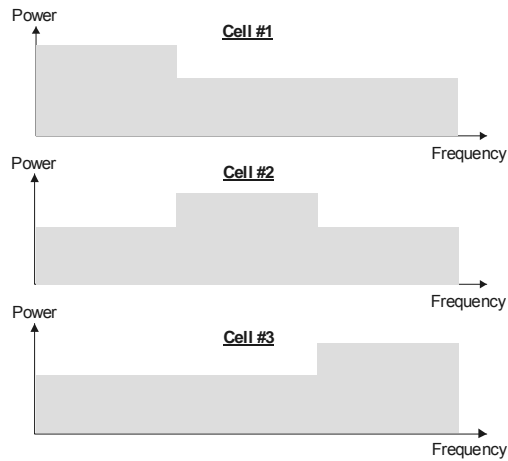

Figure 8.23 Example of downlink transmit power settings for a soft frequency re-use three

8.6.2 Uplink Interference Coordination

One proactive ICIC mechanism is standardized for the uplink, based on the High Interference Indicator (HII). The HII consists of sending a message over the X2 interface to the neighboring eNodeBs with a single bit per PRB, indicating whether the serving cell intends to schedule cell-edge UEs causing high inter-cell interference on those PRBs. Different HII messages can be sent from the serving cell to different eNodeBs. There are no standardized handshake procedures between eNodeBs. The latter means that it is open for eNodeB vendors (i.e. not

standardized by 3GPP) to decide when a new HII message is sent from an eNodeB, and the specific actions by the eNodeB receiving the message are also vendor specific. The basic idea behind the HII is that the serving cell will inform its neighboring eNodeBs at which PRBs it intends to schedule high interference users in the future. The neighboring eNodeBs should then subsequently aim at scheduling low interference users at those particular PRBs to avoid scheduling of cell-edge users at the same PRBs between two neighboring cells. Use of the HII mainly provides gain for fractional load cases, where there is only transmission on a sub-set of the PRBs per cell as in principle it can be used to dynamically achieve a hard/soft frequency re-use pattern in accordance with the offered traffic.

LTE also includes a reactive uplink ICIC scheme based on the Overload Indicator (OI). Here the basic idea is that the eNodeB measures the uplink interference+noise power, and creates OI reports based on this measurement. Low, medium, and high OI reports can be signaled over the X2 to neighboring cells. Hence, it is worth noting that the OI is primarily a function of the interference from other cells, and therefore does not include any information on the carried traffic or interference generated by the users in the serving cell. There is support for frequency selective OI, so that the aforementioned measurement and subsequent reporting to neighboring cells is per group of PRBs. One potential use is to dynamically adjust the uplink open loop power control parameters (e.g. P_o) to maintain a certain maximum desirable uplink interference+noise level (or IoT level) based on the OI information exchanged between the eNodeBs.

8.7 Discontinuous Transmission and Reception (DTX/DRX)

LTE provides methods for the UE to micro-sleep even in the active state to reduce power consumption while providing high QoS and connectivity. DRX in the LTE sense means that the UE is not monitoring the PDCCH in the given subframe and is allowed to go to power saving mode. As uplink is scheduled in downlink PDCCH, the DRX parameter impacts both uplink and downlink performance for a UE.

The DRX concept contains different user-specific parameters that are configured via higher layer signaling. These parameters are described in Table 8.3 and illustrated in simplified form in Figure 8.24.

Basically, upon knowledge of the activity requirements in uplink and downlink for a certain UE, the regular DRX period including a certain planned on-time can be set. These two parameters are illustrated in Figure 8.24a. For highly predictable traffic (e.g. VoIP), the On Duration can be set to 1 subframe and the DRX Cycle to 20 ms or 40 ms if packet staggering is used. For traffic that is more dynamic and in bursts with tight delay requirements, it is possible to configure the user with a DRX Inactivity Timer where the packet scheduler can keep the UE awake by scheduling it within a certain time window. HARQ retransmissions are planned outside of the predefined DRX cycle to allow for a tighter DRX optimization without having to plan for worst-case retransmissions. There is a DRX retransmission timer defined so that a UE does not have to wait for a full DRX cycle for an expected retransmission that has been lost due to either ACK/NACK misinterpretation or PDCCH failed detection. Signaling of SRS and CQI is tied to the DRX parameters to reduce the use of PUCCH resources when signaling is not specifically needed for link adaptation and scheduling purposes and thus increases the power saving for the UE in long DRX periods. For very long DRX periods and a long time between SRS transmissions, the network and the UE may lose the time alignment and so the UE has to restart transmission to the network using RACH. Hence, this is also a consideration

Table 8.3 DRX related parameters and examples of their use/setting [34]

DRX Parameter	Description	Example settings and purpose
DRX Cycle	Specifies the periodic repetition of the On Duration followed by a possible period of inactivity.	The overall DRX cycle is set from knowledge of the service requirements of a user (e.g. responsiveness/latency requirements) as well as requirements for other mobility/update related requirements in the cell.
On Duration timer	This parameter specifies the number of consecutive subframes the UE follows the short DRX cycle after the DRX Inactivity Timer has expired.	Depending on the user's relative scheduling priority, this parameter can be set by the network to achieve a tradeoff among multi-user scheduling performance and single-user power saving.
DRX Inactivity Timer	Specifies the number of consecutive PDCCH-subframe(s) after successfully decoding a PDCCH indicating an initial uplink or downlink user data transmission for this UE.	The parameter provides a means for the network to keep a user 'alive' when there is suddenly a large need for scheduling a UE. Hence, the mechanism allows for large power saving while facilitating high QoS for bursty traffic types. Setting is a tradeoff among scheduler freedom and UE power saving as UE is forced to continue monitoring the PDCCH whenever scheduled.
DRX Retransmission Timer	Specifies the maximum number of consecutive PDCCH-subframe(s) where a downlink retransmission is expected by the UE after the first available retransmission time.	This parameter can be set to allow for asynchronous HARQ in the downlink also for HARQ users. If disabled, the network will need to send its retransmission at the first available time. Hence, the parameter is set as a tradeoff among scheduling freedom for retransmissions and UE power saving.
DRX Short Cycle	Specifies the periodic repetition of the On Duration followed by a possible period of inactivity for the short DRX cycle.	Short DRX is basically like an inactivity timer with gaps that is more suitable for services where the incoming data become available in 'gaps'.
DRX Short Cycle Timer	This parameter specifies the number of consecutive subframe(s) the UE follows the short DRX cycle after the DRX Inactivity Timer has expired.	This parameter is set from knowledge of the service pattern. A larger setting allows for more distributed data transmission but increases UE power consumption.

for the RRM management function to properly set available DRX/SRS parameters according to the planned load on the RACH channel.

Additionally, a short DRX cycle can be triggered that allows for periodic activity within the regular DRX cycle if additional and time-distributed scheduling resources are needed to facilitate the best power saving and QoS tradeoff for the given UE. The Short DRX concept is shown in Figure 8.24b and if the UE is scheduled in the current DRX window (e.g. regular On Duration window), new scheduling opportunities are created in distributed form within the current DRX cycle. The availability of the scheduling resources is controlled by the Short DRX Inactivity Timer and if it expires, the UE returns to the normal DRX pattern immediately.

The impact of the parameter settings on web browsing experience was studied in [35]. It was shown that with a DRX period set to 100ms and the On Duration set to 1ms, the DRX

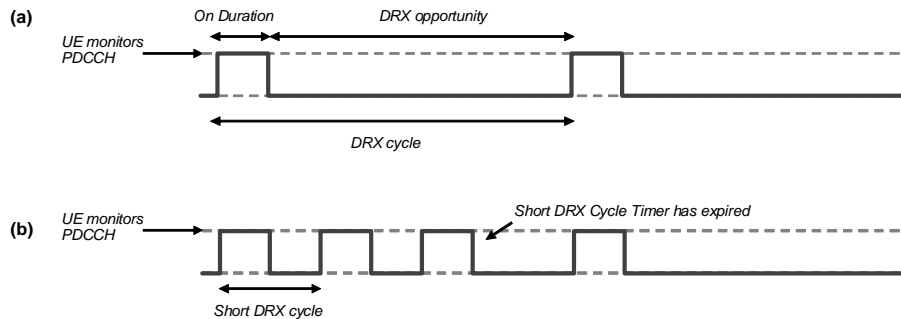

Figure 8.24 Simple illustration of DRX parameters

Inactivity timer could be set quite loosely from 25 to 50 ms while still achieving a large UE power saving, large scheduling freedom for the network, and allow for multiple web objects to be received within the active window thus improving the web browsing performance. With such settings the UE saw a 95% reduction in the radio-related power consumption while achieving 90% of the maximum achievable throughput.

Since DRX benefits UE power saving and thus is an important factor for ensuring the success of LTE, it is important to integrate its use tightly with the RRM concept in general. As the use of semi-static DRX takes the user out of the scheduling candidate set, the gain from multi-user packet scheduling may be significantly reduced. Hence, it is important that DRX parameters for a certain user are configured considering the multi-user situation in the cell as well as the service requirements for that particular user; e.g. activity needed to get the GBR requirement fulfilled or DRX period adjusted according to latency requirements. By using the span of the different DRX parameters, it is possible to effectively tune the tradeoff among scheduling flexibility for best cell-level performance and the UE's performance/power tradeoff.

8.8 RRC Connection Maintenance

The RRC connection maintenance is controlled by the eNodeB based on the RRM algorithms. When the UE has an RRC connection, the UE mobility is controlled by handovers. The handovers create some signaling traffic if the UE is moving. Therefore, if the UE is not transferring any data and is moving, it may be beneficial to release the RRC connection, while still maintaining the EPS bearer and the IP address. It may also be beneficial to release the RRC connection if the connection has been inactive for a long time or if the maximum number of RRC connections per base station is achieved. Example triggers for RRC connection release are illustrated in Figure 8.25. When the UE next transmits or receives data, the RRC connection is again re-established via RACH procedure.

8.9 Summary

The radio resource management algorithms are important to optimize the system capacity and end user performance. The network algorithms are not standardized but the network vendors

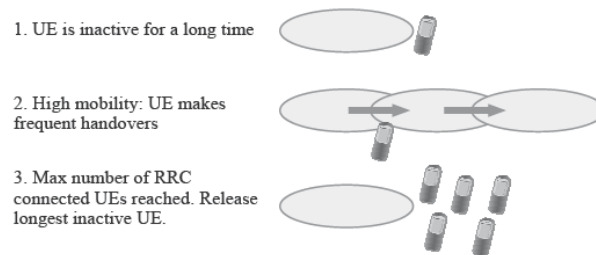

Figure 8.25 Triggers for RRC connection release

and operators can design and tune the algorithms according to the needs. The main algorithms in LTE are packet scheduling, admission control, power control and interference control. The LTE radio gives a lot of freedom in the packet scheduling area since the scheduling can be done in both the time and the frequency domain. It is shown that frequency domain scheduling can provide a clear capacity benefit at low mobile speeds compared to random scheduling. The uplink scheduling has less freedom compared to the downlink because the signaling from the network to the terminal takes time and because SC-FDMA transmission in uplink must use adjacent resource blocks.

The signaling in 3GPP has been defined to support efficient scheduling including the downlink Channel Quality Information (CQI), uplink Sound Reference Signals (SRS), uplink Buffer Status Reports (BSR) and uplink Power Headroom Reports (PHR).

The QoS differentiation allows separate treatment for different services, applications, subscribers or depending on the used amounts of data. The QoS is relevant in LTE since all the services are packet based including voice. The QoS concept in LTE is fully network controlled and is simplified compared to the existing 2G/3G networks. The QoS priority is typically achieved in time domain scheduling.

The LTE interface specifications support the inter-cell interference coordination to achieve dynamic frequency re-use configurations. The co-ordination can be used to optimize the resource allocation in the adjacent cells to maximize the cell edge throughput.

Discontinuous transmission and reception (DTX/DRX) is important to minimize the UE power consumption and to maximize the operating times for the handheld devices. The tuning of the DTX/DRX parameters also needs to consider the scheduling performance and the end to end performance.

References

- [1] D. Niyato, E. Hossain, 'Connection Admission Control Algorithms for OFDM Wireless Networks', IEEE Proc. Globecom, pp. 2455–2459, September 2005.
- [2] P. Hosein, 'A Class-Based Admission Control Algorithm for Shared Wireless Channels Supporting QoS Services', in Proceedings of the Fifth IFIP TC6 International Conference on Mobile and Wireless Communications Networks, Singapore, October 2003.
- [3] K.I. Pedersen, 'Quality Based HSDPA Access Algorithms', in IEEE Proc. Vehicular Technology Conference Fall, September 2005.
- [4] 3GPP 23.401, 'Technical Specification Group Services And System Aspects; GPRS enhancements for E-UTRAN access (Release 8)', August 2007.

- [5] 3GPP 23.203, 'Technical Specification Group Services and System Aspects; Policy and charging control architecture', v. 8.3.1.
- [6] 3GPP 36.300 'Technical Specification Group Radio Access Network; Evolved Universal Terrestrial Radio Access (E-UTRA) and Evolved Universal Terrestrial Radio Access Network (E-UTRAN); Overall description; Stage 2 (Release 8)', October 2007.
- [7] A. Pokhariyal, *et al.*, 'HARQ Aware Frequency Domain Packet Scheduler with Different Degrees of Fairness for the UTRAN Long Term Evolution', IEEE Proc. Vehicular Technology Conference, pp. 2761–2765, April 2007.
- [8] K.I. Pedersen, F. Frederiksen, T.E. Kolding, T.F. Lootsma, P.E. Mogensen, 'Performance of High Speed Downlink Packet Access in Co-existence with Dedicated Channels', IEEE Trans. Vehicular Technology, Vol. 56, No. 3, pp. 1261–1271, May 2007.
- [9] A. Simonsson, 'Frequency Reuse and Intercell Interference Co-ordination in E-UTRA', IEEE Proc. Vehicular Technology Conference, pp. 3091–3095, April 2007.
- [10] A. Pokhariyal, *et al.*, 'Frequency Domain Packet Scheduling Under Fractional Load for the UTRAN LTE Downlink', IEEE Proc. Vehicular Technology Conference, pp. 699–703, April 2007.
- [11] H. Holma, A. Toskala, 'WCDMA for UMTS – HSPA Evolution and LTE', 4th edition, Wiley, 2007.
- [12] K.I. Pedersen, P.E. Mogensen, Troels E. Kolding, 'Overview of QoS Options for HSDPA', IEEE Communications Magazine, Vol. 44, No. 7, pp. 100–105, July 2006.
- [13] P.A. Hosein, 'QoS Control for WCDMA High Speed Packet Data', IEEE Proc. Vehicular Technology Conference 2002.
- [14] D. Laselva, *et al.*, 'Optimization of QoS-aware Packet Schedulers in Multi-Service Scenarios over HSDPA', 4th International Symposium on Wireless Communications Systems, pp. 123 – 127, ISWCS 2007, 17–19 October 2007.
- [15] T.E. Kolding, 'QoS-Aware Proportional Fair Packet Scheduling with Required Activity Detection', IEEE Proc. Vehicular Technology Conference, September 2006.
- [16] G. Barriac, J. Holtzman, "Introducing Delay Sensitivity into the Proportional Fair algorithm for CDMA Downlink Scheduling", IEEE Proc. ISSSTA, pp. 652–656, September 2002.
- [17] M. Andrews, K. Kumaran, K. Ramanan, A. Stolyar, P. Whiting, 'Providing Quality of Service over a Shared Wireless Link', IEEE Communications Magazine, Vol. 39, No. 2, pp. 150–154, February 2001.
- [18] F. Kelly, 'Charging and rate control for elastic traffic', European Trans. On Telecommunications, No. 8, pp. 33–37, 1997.
- [19] J.M. Holtzman, "Asymptotic Analysis of Proportional Fair Algorithm", IEEE Proc. PIMRC, Personal Indoor and Mobile Radio Communication Conference, pp. F33–F37, September 2000.
- [20] G. Song, Y. Li, 'Utility-Based Resource Allocation and Scheduling in OFDM-Based Wireless Broadband Networks', IEEE Communications Magazine, pp. 127–134, December 2005.
- [21] G. Monghal, *et al.*, 'QoS Oriented Time and Frequency Domain Packet Schedulers for The UTRAN Long Term Evolution', in IEEE Proc. VTC-2008 Spring, May 2008.
- [22] C. Wengerter, J. Ohlhorst, A.G.E. v. ElbWart, 'Fairness and throughput analysis for Generalized Proportional Fair Frequency Scheduling in OFDMA', IEEE Proc. of Vehicular Technology Conference, pp. 1903–1907, Sweden, May 2005.
- [23] H. Yang, 'A Road to Future Broadband Wireless Access: MIMO-OFDM-Based Air Interface', IEEE Communication Magazine, pp. 553–560, January 2005.
- [24] I. Viering, A. Klein, M. Ivrlac, M. Castaneda, J.A. Nossek, 'On Uplink Intercell Interference in a Cellular System', IEEE International Conference on Communications (ICC), Vol. 5, pp. 2095–2100, Istanbul, Turkey, June 2006.
- [25] C. Rosa, D. López Villa, C. Úbeda Castellanos, F.D. Calabrese, P. Michaelson, K.I. Pedersen, Peter Skov, 'Performance of Fast AMC in E-UTRAN Uplink', IEEE International Conference on Communications (ICC 2008), May 2008.
- [26] 3GPP TS 36.213, 'Technical Specification Group Radio Access Network; Physical layer procedures (Release 8)', November 2007.
- [27] C. Úbeda Castellanos, D. López Villa, C. Rosa, K.I. Pedersen, F.D. Calabrese, P. Michaelson, J. Michel, 'Performance of Uplink Fractional Power Control in UTRAN LTE', IEEE Trans. on Vehicular Technology, May 2008.
- [28] R1-080900, 'Physical-layer parameters to be configured by RRC', TSG RAN WG1 #52, Sorrento, Italy, 11–15 February 2008.

- [29] R1-060048, 'Channel-Dependent Packet Scheduling for Single-Carrier FDMA in E-UTRA Uplink', 3GPP TSG RAN WG1 LTE Ad Hoc Meeting, Helsinki, Finland, 23–25 January 2006.
- [30] 3GPP TS 36.321, 'Technical Specification Group Radio Access Network; Medium Access Control (MAC) protocol specification (Release 8)', March 2008.
- [31] J. Lim, H.G. Myung, D.J. Goodman, 'Proportional Fair Scheduling of Uplink Single Carrier FDMA Systems', IEEE Personal Indoor and Mobile Radio Communication Conference (PIMRC), Helsinki, Finland, September 2006.
- [32] F.D. Calabrese, P.H. Michaelsen, C. Rosa, M. Anas, C. Úbeda Castellanos, D. López Villa, K.I. Pedersen, P.E. Mogensen, 'Search-Tree Based Uplink Channel Aware Packet Scheduling for UTRAN LTE', in IEEE Proc. Vehicular Technology Conference, 11–14 May 2008.
- [33] R1-060188, 'Frequency-domain user multiplexing for the E-UTRAN downlink', 3GPP TSG RAN WG1 LTE Ad Hoc Meeting, Helsinki, Finland, 23–25 January 2006.
- [34] 3GPP 36.321 Technical Specifications 'Medium Access Control (MAC) protocol specification', v. 8.3.0.
- [35] T. Kolding, J. Wigard, L. Dalsgaard, 'Balancing Power Saving and Single-User Experience with Discontinuous Reception in LTE', Proc. of IEEE International Symposium on Wireless Communication Systems (ISWCS), Reykjavik, Iceland, October 2008.

9

Performance

Harri Holma, Pasi Kinnunen, István Z. Kovács, Kari Pajukoski, Klaus Pedersen and Jussi Reunanen

9.1 Introduction

This chapter illustrates LTE capabilities from the end user's and from the operator's point of view. Radio performance has a direct impact on the cost of deploying the network in terms of the required number of base station sites and in terms of the transceivers required. The operator is interested in the network efficiency: how many customers can be served, how much data can be provided and how many base station sites are required. The efficiency is considered in the link budget calculations and in the capacity simulations. The end user application performance depends on the available bit rate, latency and seamless mobility. The radio performance defines what applications can be used and how these applications perform.

The link level studies in this chapter illustrate the main factors affecting LTE performance including mobile speed and transmission bandwidth. The LTE link performance is benchmarked with the theoretical Shannon limit. The capacity studies present the impact of the environment and show the bit rate distributions in typical network deployments. The relative capacity gains compared to HSPA networks are shown analytically and with simulations. The chapter presents also general dimensioning guidelines and the specific aspects of refarming LTE to the GSM spectrum. The network capacity management is illustrated with examples from High Speed Packet Access (HSPA) networks.

Practical performance is also impacted by the performance of the commercial UE and eNodeBs. To guarantee consistent performance, 3GPP has defined a set of radio performance requirements. 3GPP performance requirements are explained in detail in Chapter 11.

9.2 Layer 1 Peak Bit Rates

LTE provides high peak bit rates by using a large bandwidth up to 20 MHz, high order 64QAM modulation and multistream MIMO transmission. Quadrature Phase Shift Keying (QPSK) modulation carries 2 bits per symbol, 16QAM 4 bits and 64QAM 6 bits. 2×2 MIMO

further doubles the peak bit rate up to 12 bits per symbol. Therefore, QPSK $\frac{1}{2}$ rate coding carries 1 bps/Hz while 64QAM without any coding and with 2×2 Multiple Input Multiple Output (MIMO) carries 12 bps/Hz. The bandwidth is included in the calculation by taking the corresponding number of resource blocks for each bandwidth option: 6 with 1.4 MHz and 15 with 3 MHz bandwidth. The number of resource blocks for the bandwidths 5, 10, 15 and 20 MHz are 25, 50, 75 and 100 respectively. We assume the following control and reference signal overheads:

- Physical Downlink Control Channel (PDCCH) takes one symbol out of 14 symbols. That is the minimum possible PDCCH allocation. It is enough when considering single user peak bit rate. The resulting control overhead is 7.1% ($=1/14$).
- Downlink Reference Signals (RS) depend on the antenna configuration. Single stream transmission uses 2 RS out of 14 in every 3rd sub-carrier, 2×2 MIMO 4 symbols and 4×4 MIMO 6 symbols. The overhead varies between 4.8% and 14.3%. The RS partly overlap with PDCCH and the overlapping is taken into account.
- Other downlink symbols are subtracted: synchronization signal, Physical Broadcast Channel (PBCH), Physical Control Format Indicator Channel (PCFICH) and one group of Physical Hybrid Automatic Repeat Request Indicator Channel (PHICH). The overhead depends on the bandwidth ranging from below 1% at 20 MHz to approximately 9% at 1.4 MHz.
- No Physical Uplink Control Channel (PUCCH) is included in the calculation. PUCCH would slightly reduce the uplink data rate.
- Uplink reference signals take 1 symbol out of 7 symbols resulting in an overhead of 14.3% ($=1/7$).

The achievable peak bit rates are shown in Table 9.1 The highest theoretical data rate is approximately 172 Mbps. If 4×4 MIMO option is applied, the theoretical peak data rate increases to 325 Mbps. The bit rate scales down according to the bandwidth. The 5-MHz peak bit rate is 42.5 Mbps and 1.4-MHz 8.8 Mbps with 2×2 MIMO.

The uplink peak data rates are shown in Table 9.2: up to 86 Mbps with 64QAM and up to 57 Mbps with 16QAM with 20 MHz. The peak rates are lower in uplink than in downlink since single user MIMO is not specified in uplink in 3GPP Release 8. The single user MIMO

Table 9.1 Downlink peak bit rates (Mbps)

Resource blocks			1.4 MHz	3.0 MHz	5.0 MHz	10 MHz	15 MHz	20 MHz
Modulation and coding	Bits/symbol	MIMO usage	6	15	25	50	75	100
QPSK 1/2	1.0	Single stream	0.8	2.2	3.7	7.4	11.2	14.9
16QAM 1/2	2.0	Single stream	1.5	4.4	7.4	14.9	22.4	29.9
16QAM 3/4	3.0	Single stream	2.3	6.6	11.1	22.3	33.6	44.8
64QAM 3/4	4.5	Single stream	3.5	9.9	16.6	33.5	50.4	67.2
64QAM 1/1	6.0	Single stream	4.6	13.2	22.2	44.7	67.2	89.7
64QAM 3/4	9.0	2×2 MIMO	6.6	18.9	31.9	64.3	96.7	129.1
64QAM 1/1	12.0	2×2 MIMO	8.8	25.3	42.5	85.7	128.9	172.1
64QAM 1/1	24.0	4×4 MIMO	16.6	47.7	80.3	161.9	243.5	325.1

Table 9.2 Uplink peak bit rates (Mbps)

Resource blocks			1.4 MHz	3.0 MHz	5.0 MHz	10 MHz	15 MHz	20 MHz
Modulation and coding	Bits/symbol	MIMO usage	6	15	25	50	75	100
QPSK 1/2	1.0	Single stream	0.9	2.2	3.6	7.2	10.8	14.4
16QAM 1/2	2.0	Single stream	1.7	4.3	7.2	14.4	21.6	28.8
16QAM 3/4	3.0	Single stream	2.6	6.5	10.8	21.6	32.4	43.2
16QAM 1/1	4.0	Single stream	3.5	8.6	14.4	28.8	43.2	57.6
64QAM 3/4	4.5	Single stream	3.9	9.7	16.2	32.4	48.6	64.8
64QAM 1/1	6.0	Single stream	5.2	13.0	21.6	43.2	64.8	86.4

in uplink would require two power amplifiers in the terminal. MIMO can be used in Release 8 uplink as well to increase the aggregate cell capacity, but not single user peak data rates. The cell level uplink MIMO is called Virtual MIMO (V-MIMO) where the transmission from two terminals, each with single antenna, is organized so that the cell level peak throughput can be doubled.

The transport block sizes in [1] have been defined so that uncoded transmission is not possible. The maximum achievable bit rates taking the transport block sizes into account are shown in Table 9.3 for downlink and in Table 9.4 for uplink for the different modulation schemes. The downlink peak rate with 2×2 MIMO goes up to 150 Mbps and the uplink rate up to 75 Mbps. The calculations assume that uplink 16QAM uses Transport Block Size

Table 9.3 Downlink peak bit rates with transport block size considered (Mbps)

Resource blocks			1.4 MHz	3.0 MHz	5.0 MHz	10 MHz	15 MHz	20 MHz
Modulation and coding	MIMO usage		6	15	25	50	75	100
QPSK	Single stream		0.9	2.3	4.0	8.0	11.8	15.8
16QAM	Single stream		1.8	4.3	7.7	15.3	22.9	30.6
64QAM	Single stream		4.4	6.5	18.3	36.7	55.1	75.4
64QAM	2×2 MIMO		8.8	8.6	36.7	73.7	110.1	149.8

Table 9.4 Uplink peak bit rates with transport block size considered (Mbps)

Resource blocks			1.4 MHz	3.0 MHz	5.0 MHz	10 MHz	15 MHz	20 MHz
Modulation and coding	MIMO usage		6	15	25	50	75	100
QPSK	Single stream		1.0	2.7	4.4	8.8	13.0	17.6
16QAM	Single stream		3.0	7.5	12.6	25.5	37.9	51.0
64QAM	Single stream		4.4	11.1	18.3	36.7	55.1	75.4

(TBS) index 21, uplink QPSK uses TBS index 10, downlink 16QAM uses TBS index 15 and downlink QPSK uses TBS index 9.

The original LTE target was peak data rates of 100 Mbps in downlink and 50 Mbps in uplink, which are clearly met with the 3GPP Release 8 physical layer.

9.3 Terminal Categories

3GPP Release 8 has defined five terminal categories having different bit rate capabilities. Category 1 is the lowest capability with maximum bit rates of 10 Mbps downlink and 5 Mbps uplink while Category 5 is the highest capability with data rates of 300 Mbps in downlink and 75 Mbps uplink. The bit rate capability in practice is defined as the maximum transport block size that the terminal is able to process in 1 ms.

All categories must support all RF bandwidth options from 1.4 to 20 MHz, 64QAM modulation in downlink and 1–4 transmission branches at eNodeB. The receive antenna diversity is mandated via performance requirements. The support of MIMO transmission depends on the category. Category 1 does not need to support any MIMO while categories 2–4 support 2×2 MIMO and Category 5 support 4×4 MIMO. The uplink modulation is up to 16QAM in categories 1–4 while 64QAM is required in category 5.

The terminal categories are shown in Table 9.5. Further terminal categories may be defined in later 3GPP releases. The initial LTE deployment phase is expected to have terminal categories 2, 3 and 4 available providing downlink data rates up to 150 Mbps and supporting 2×2 MIMO.

Table 9.5 Terminal categories [2]

	Category 1	Category 2	Category 3	Category 4	Category 5
Peak rate downlink (approximately)	10 Mbps	50 Mbps	100 Mbps	150 Mbps	300 Mbps
Peak rate uplink (approximately)	5 Mbps	25 Mbps	50 Mbps	50 Mbps	75 Mbps
Max bits received within TTI	10 296	51 024	102 048	149 776	299 552
Max bits transmitted within TTI	5 160	25 456	51 024	51 024	75 376
RF bandwidth	20 MHz	20 MHz	20 MHz	20 MHz	20 MHz
Modulation downlink	64QAM	64QAM	64QAM	64QAM	64QAM
Modulation uplink	16QAM	16QAM	16QAM	16QAM	64QAM
Receiver diversity	Yes	Yes	Yes	Yes	Yes
eNodeB diversity	1–4 tx	1–4 tx	1–4 tx	1–4 tx	1–4 tx
MIMO downlink	Optional	2×2	2×2	2×2	4×4

9.4 Link Level Performance

9.4.1 Downlink Link Performance

The peak data rates are available only in extremely good channel conditions. The practical data rate is limited by the amount of interference and noise in the network. The maximum theoretical data rate with single antenna transmission in static channel can be derived using the Shannon formula. The formula gives the data rate as a function of two parameters: bandwidth and the received Signal-to-Noise Ratio (SNR).

$$\text{Bit rate [Mbps]} = \text{Bandwidth [MHz]} \cdot \log_2(1 + \text{SNR}) \quad (9.1)$$

The Shannon capacity bound in equation (9.1) cannot be reached in practice due to several implementation issues. To represent these loss mechanisms accurately, we use a modified Shannon capacity formula [3]:

$$\text{Bit rate [Mbps]} = BW_eff \cdot \text{Bandwidth [MHz]} \cdot \log_2(1 + \text{SNR}/\text{SNR_eff}) \quad (9.2)$$

where BW_eff accounts for the system bandwidth efficiency of LTE and SNR_eff accounts for the SNR implementation efficiency of LTE.

The bandwidth efficiency of LTE is reduced by several issues, as listed in Table 9.6. Due to the requirements of the Adjacent Channel Leakage Ratio (ACLR) and practical filter implementation, the bandwidth occupancy is reduced to 0.9. The overhead of the cyclic prefix is approximately 7% and the overhead of pilot assisted channel estimation is approximately 6% for single antenna transmission. For dual antenna transmission the overhead is approximately doubled to 11%. Note that here ideal channel estimation is used, which is the reason why the pilot overhead is not included in the link performance bandwidth efficiency but must be included in the system bandwidth level efficiency [3]. This issue also impacts the SNR_eff . The overall link-level bandwidth efficiency is therefore approximately 83%.

When fitting Equation 9.2 to the Shannon performance curve in Additive White Gaussian Noise (AWGN) channel conditions, we extract the best value for SNR_eff using the setting for BW_eff of 0.83 from Table 9.6 and the fitting parameters are indicated in parentheses as (BW_eff, SNR_eff) . The results are presented in Figure 9.1. We can observe that LTE is performing less than 1.6~2 dB off from the Shannon capacity bound. There is nevertheless a minor discrepancy in both ends of the G-factor dynamic range. This is because the SNR_eff

Table 9.6 Link bandwidth efficiency for LTE downlink with a 10 MHz system

Impairment	Link BW_eff	System BW_eff
BW efficiency	0.90	0.90
Cyclic prefix	0.93	0.93
Pilot overhead	–	0.94
Dedicated and common control channels	–	0.715
Total	0.83	0.57

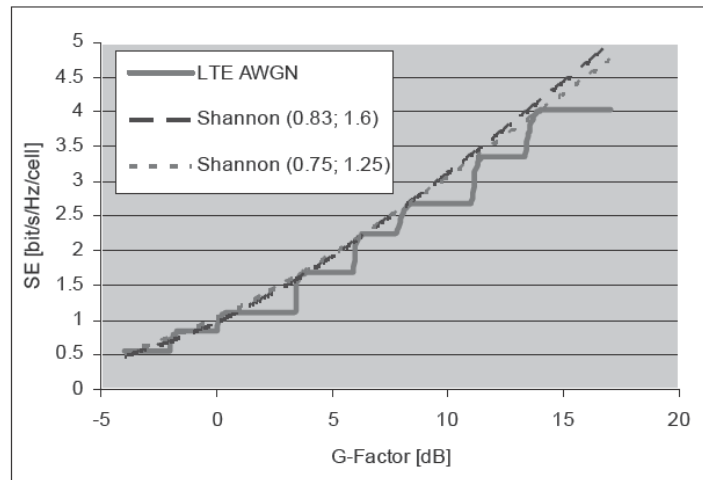

Figure 9.1 LTE spectral efficiency (SE) as a function of G-factor (in dB) including curves for best Shannon fit. The steps are due to the limited number of modulation and coding schemes in the simulation [3]. © 2007 IEEE

is not constant but changes with the G-factor. It is shown in [3] that this dependency can be accounted for using the fudge factor, η , multiplying the BW_{eff} parameter. For AWGN, $\eta = 0.9$ ($BW_{eff} * \eta = 0.75$) and $SNR_{eff} = 1.0$. The best fit to the link adaptation curve [3] is 1.25 dB.

In Figure 9.2 we show the spectral efficiency results versus G-factor from LTE link level studies and the best Shannon fit for a 3 km/h typical urban fading channel. Different antenna configurations are presented: single antenna transmission and reception Single Input Single Output (SISO) (1×1), single antenna transmission and antenna receive diversity Single Input Multiple Output (SIMO) (1×2) and Closed Loop MIMO (2×2). Using the G-factor dependent SNR_{eff} we achieve a visibly almost perfect fit to the link simulation results. For SISO it can be observed that the best Shannon fit parameters are significantly worsened compared to AWGN: the equivalent BW_{eff} has reduced from 0.83 to 0.56 (corresponding to fudge factor $\eta = 0.6$) and the SNR_{eff} parameter is increased from 1.6~2 dB to 2~3 dB. The match between the fitted Shannon curves and the actual link-level results is not perfect but sufficiently close for practical purposes.

These link-level results show that LTE downlink with ideal channel estimation performs approximately 2 dB from Shannon Capacity in AWGN, whereas the deviation between Shannon and LTE becomes much larger for a fading channel. This fading loss can, however, be compensated with the multi-user diversity gain when using frequency domain packet scheduling and the fitted Shannon curves can also include the system level scheduling gain [3]. With these adjustments, cell capacity results can be accurately estimated from the suggested modified Shannon formula and a G-Factor distribution according to a certain cellular scenario.

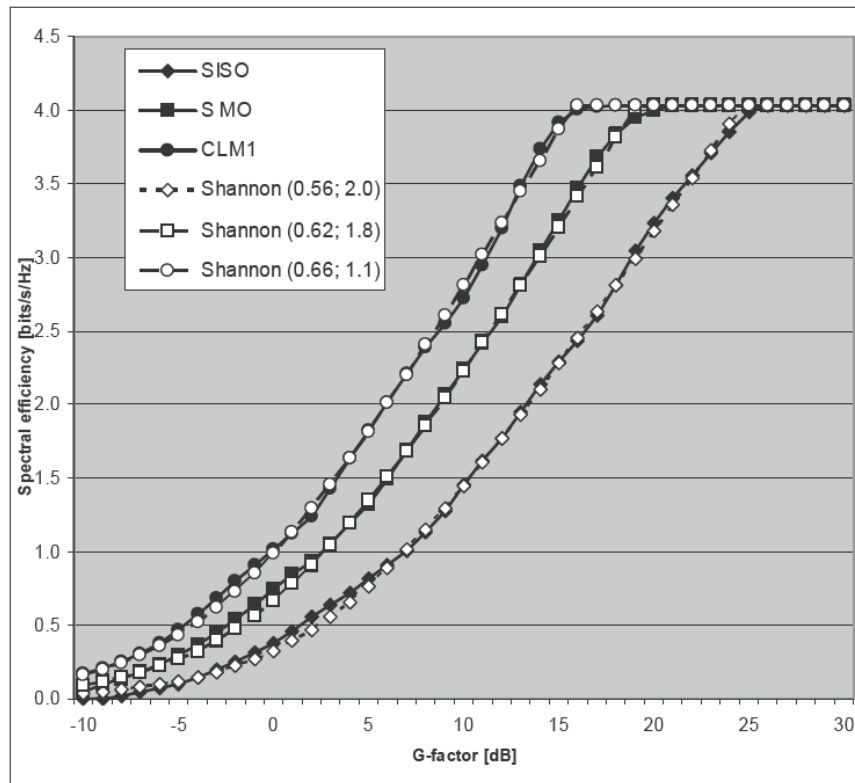

Figure 9.2 Spectral efficiency for SISO (1×1), SIMO (1×2) and Closed loop MIMO (2×2), as a function of G-factor. The best Shannon fit curves are plotted with parameters (BW_{eff} , SNR_{eff}) using Equation 9.2 [3]

9.4.2 Uplink Link Performance

9.4.2.1 Impact of Transmission Bandwidth

The uplink coverage can be optimized by bandwidth selection in LTE. The bandwidth adaptation allows the UE power to be emitted in an optimum bandwidth, which extends the coverage compared to having a fixed transmission bandwidth. A larger number of channel parameters need to be estimated for the wideband transmissions, which reduces the accuracy of the channel estimation due to noise. The optimized transmission bandwidth in LTE enables more accurate channel estimation for the lower data rates compared to WCDMA/HSUPA.

In Figure 9.3, the throughput as a function of SNR with different bandwidth allocation is shown. The smallest bandwidth allocation, 360 kHz, optimizes the coverage for bit rates below 100 kbps. The moderate bandwidth allocation, 1.08 MHz, gives the best coverage for bit rates

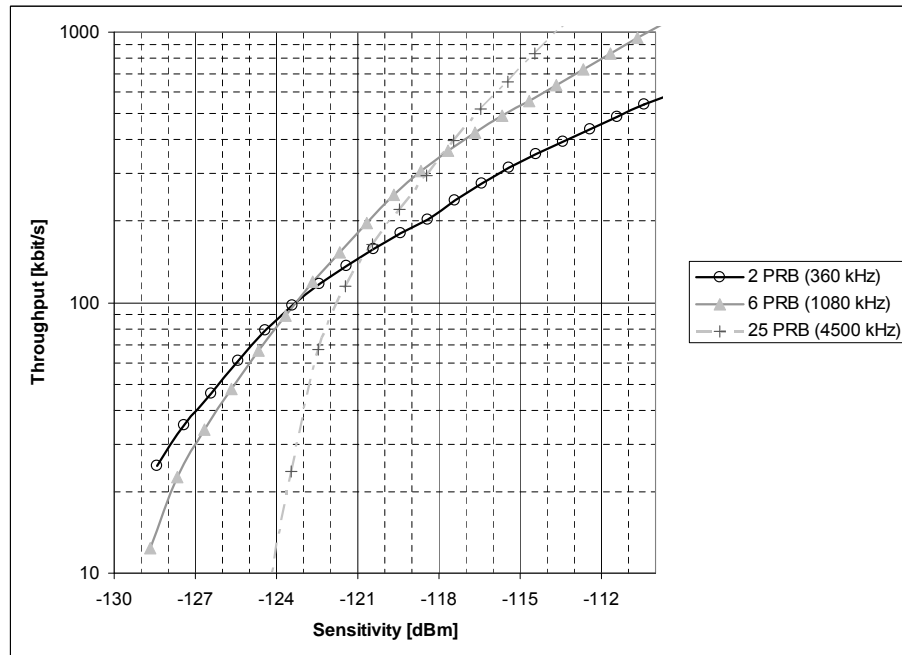

Figure 9.3 LTE eNodeB sensitivity as a function of received power with allocation bandwidths of 360 kHz, 1.08 MHz and 4.5 MHz

from 100 kbps to 360 kbps. The assumed base station noise figure is 2 dB and no interference margin is included.

9.4.2.2 Impact of Mobile Speed

Figure 9.4 shows the link adaptation curve of LTE uplink for the UE speeds of 3, 50, 120 and 250 km/h. The received pilot signals are utilized for channel estimation. The channel estimation is based on Wiener filter in both time and frequency domain. The impact of the mobile speed is small at low data rates while at high data rates the very high mobile speed of 250 km/h shows 30% lower throughput than at 3 km/h.

The required SNR values for various link efficiencies are given in Figure 9.5. In the efficiency range of QPSK (0.1–1 bits/Hz), the LTE uplink performance is affected only by 1–1.5 dB, when increasing UE speed from 3 to 250 km/h. For higher order modulations, 16QAM and 64QAM, the impact of the UE speed is higher – up to 3 dB for the efficiency of 2 bps/Hz/cell. In general, LTE uplink is robust against Doppler frequency shifts. The UE speed affects the throughput and SNR requirements mainly due to channel estimation performance: when the channel is changing fast, it is not possible to use a long averaging time and the accuracy of the channel estimation is impacted.

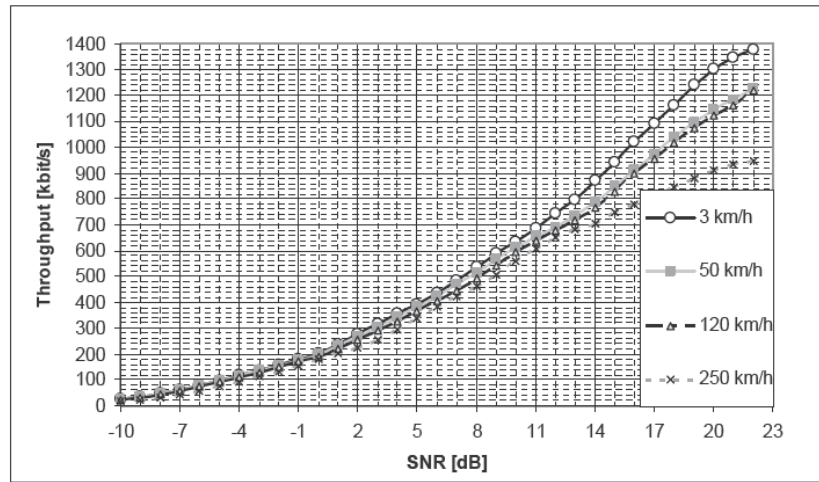

Figure 9.4 LTE eNodeB throughput as a function of SNR with UE speeds of 3 km/h, 50 km/h, 120 km/h and 250 km/h

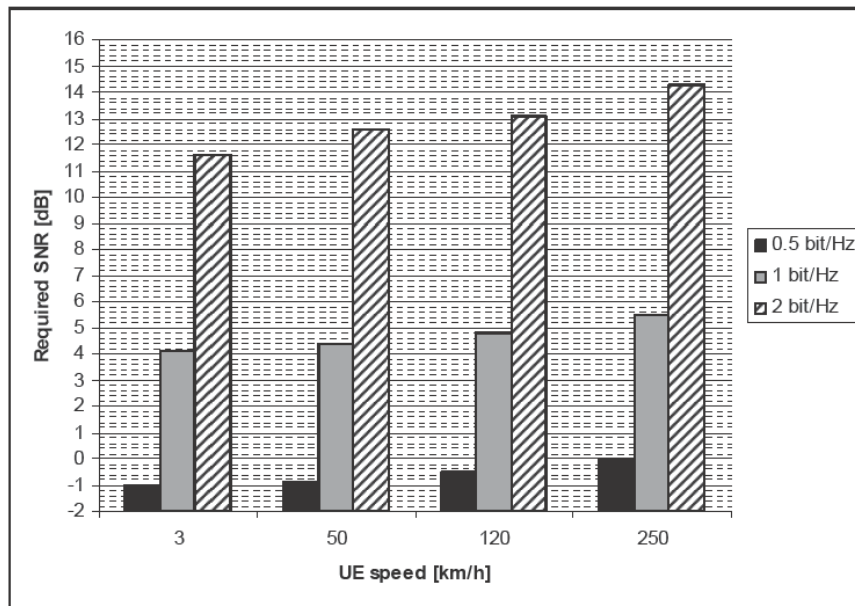

Figure 9.5 Required SNR values for various spectral efficiencies with UE speeds of 3 km/h, 50 km/h, 120 km/h and 250 km/h

9.5 Link Budgets

The link budget calculations estimate the maximum allowed signal attenuation, called path loss, between the mobile and the base station antenna. The maximum path loss allows the maximum cell range to be estimated with a suitable propagation model, such as Okumura–Hata. The cell range gives the number of base station sites required to cover the target geographical area. The link budget calculation can also be used to compare the relative coverage of the different systems. The relative link budget indicates how well the new LTE radio system will perform when it is deployed on the existing base station sites that are designed for GSM and WCDMA.

The parameters for the LTE link budget for uplink are introduced in Table 9.7, and the link budget is presented in Table 9.8. The corresponding LTE downlink link budget parameters are presented in Table 9.9, and the link budget in Table 9.10. The link budgets are calculated for 64 kbps uplink with 2-antenna base station receive diversity and 1 Mbps downlink with 2-antenna mobile receive diversity. For reference, the link budgets for GSM voice and for HSPA data are illustrated as well.

The LTE link budget in downlink has several similarities with HSPA and the maximum path loss is similar. The uplink part has some differences: smaller interference margin in LTE, no macro diversity gain in LTE and no fast fading margin in LTE. The maximum path loss values are summarized in Figure 9.6. The link budgets show that LTE can be deployed using existing GSM and HSPA sites assuming that the same frequency is used for LTE as for GSM and HSPA. LTE itself does not provide any major boost in the coverage. That is because the transmission power levels and the RF noise figures are also similar in GSM and HSPA technologies, and the link performance at low data rates is not much different in LTE than in HSPA.

The link budget was calculated for 64 kbps uplink, which is likely not a high enough data rate for true broadband service. If we want to guarantee higher data rates in LTE, we may need low frequency deployment, additional sites, active antenna solutions or local area solutions.

The coverage can be boosted by using a lower frequency since a low frequency propagates better than a higher frequency. The benefit of the lower frequency depends on the environment and on its use. The difference between 900 MHz and 2600 MHz is illustrated in Table 9.11. Part of the benefit of the lower frequency is lost since the antenna gains tend to get smaller at a lower frequency band. To maintain the antenna gain at lower frequency would require a physically larger antenna which is not always feasible at base station sites and in small terminals. The greatest benefits from low frequencies can be obtained when the base station site can use large antennas 2.5 m high and where the external antenna can be used in the terminal. This is fixed wireless deployment.

Example cell ranges are shown in Figure 9.7. Note that the y-axis has a logarithmic scale. The cell range is shown for 900 MHz, 1800 MHz, 2100 MHz and 2600 MHz frequency variants. These frequencies do not cover all possible LTE frequency variants. Typical US frequencies would be 700 MHz and 1700/2100 MHz, but the end result would be very similar to the values in Figure 9.7. The cell ranges are calculated using the Okumura–Hata propagation model with the parameters shown in Table 9.12. The urban cell range varies from 0.6 km to 1.4 km and suburban from 1.5 km to 3.4 km. Such cell ranges are also typically found in existing GSM and UMTS networks. The rural case shows clearly higher cell ranges: 26 km for the outdoor mobile coverage and even up to 50 km for the rural fixed installation at 900 MHz.

Note that the earth's curvature limits the maximum cell range to approximately 40 km with an 80 m high base station antenna assuming that the terminal is at ground level. The maximum

Table 9.7 Uplink link budget parameters for LTE

Field	Description	Typical value
a	UE maximum transmission power for power class 3. Different power classes would have different power levels. The power can be reduced depending on the modulation, see Chapter 11 for details.	23 dBm
b	UE antenna gain depends on the type of device and on the frequency band. Small handheld terminal at a low frequency band (like Band VIII) can have an antenna gain of -5 dBi while a fixed wireless terminal with directive antenna can have a gain of up to 10 dBi.	-5 to 10 dBi
c	Body loss is typically included for voice link budget where the terminal is held close to the user's head.	3 to 5 dB for voice
d	Calculated as $a + b - c$	
e	Base station RF noise figure. Depends on the implementation design. The minimum performance requirement is approximately 5 dB but the practical performance can be better.	2 dB
f	Terminal noise can be calculated as k (Boltzmann constant) $\times T$ (290K) \times bandwidth. The bandwidth depends on bit rate, which defines the number of resource blocks. We assume two resource blocks for 64 kbps uplink.	-118.4 dBm for two resource blocks (360 kHz)
g	Calculated as $e + f$	
h	Signal-to-noise ratio from link simulations or measurements. The value depends on the modulation and coding schemes, which again depend on the data rate and on the number of resource blocks allocated.	-7 dB for 64 kbps and two resource blocks
i	Calculated as $g + h$	
j	Interference margin accounts for the increase in the terminal noise level caused by the interference from other users. Since LTE uplink is orthogonal, there is no intra-cell interference but we still need a margin for the other cell interference. The interference margin in practice depends heavily on the planned capacity – there is a tradeoff between capacity and coverage. The LTE interference margin can be smaller than in WCDMA/HSUPA where the intra-cell users are not orthogonal. In other words, the cell breathing will be smaller in LTE than in CDMA based systems.	1 to 10 dB
k	Cable loss between the base station antenna and the low noise amplifier. The cable loss value depends on the cable length, cable type and frequency band. Many installations today use RF heads where the RF parts are close to the antenna making the cable loss very small. The cable loss can also be compensated by using mast head amplifiers.	1 to 6 dB
l	Base station antenna gain depends on the antenna size and the number of sectors. Typical 3-sector antenna 1.3 m high at 2 GHz band gives 18 dBi gain. The same size antenna at 900 MHz gives smaller gain.	15 to 21 dBi for sectorized base station
m	Fast fading margin is typically used with WCDMA due to fast power control to allow headroom for the power control operation. LTE does not use fast power control and the fast fading margin is not necessary in LTE.	0 dB
n	Soft handover is not used in LTE	0 dB

Table 9.8 Uplink link budgets

Uplink		GSM voice	HSPA	LTE
Data rate (kbps)		12.2	64	64
Transmitter – UE				
a	Max tx power (dBm)	33.0	23.0	23.0
b	Tx antenna gain (dBi)	0.0	0.0	0.0
c	Body loss (dB)	3.0	0.0	0.0
d	EIRP (dBm)	30.0	23.0	23.0
Receiver – Node B				
e	Node B noise figure (dB)	–	2.0	2.0
f	Thermal noise (dB)	–119.7	–108.2	–118.4
g	Receiver noise (dBm)	–	–106.2	–116.4
h	SINR (dB)	–	–17.3	–7.0
i	Receiver sensitivity	–114.0	–123.4	–123.4
j	Interference margin (dB)	0.0	3.0	1.0
k	Cable loss (dB)	0.0	0.0	0.0
l	Rx antenna gain (dBi)	18.0	18.0	18.0
m	Fast fade margin (dB)	0.0	1.8	0.0
n	Soft handover gain (dB)	0.0	2.0	0.0
Maximum path loss		162.0	161.6	163.4

cell range can be calculated with Equation 9.3, where R is the effective earth radius of 8650 km, h is the base station antenna height and d is the distance from the terminal to the base station. The calculation is illustrated in Figure 9.8. To achieve 100 km cell range, the required antenna height is 580 m, which in practice is feasible if the base station antenna is located on a mountain pointing towards the sea or other flat terrain.

$$R^2 + d^2 = (R + h)^2 \quad (9.3)$$

$$h = \sqrt{R^2 + d^2} - R$$

9.6 Spectral Efficiency

This section presents the typical spectral efficiency of LTE downlink and uplink in terms of bps/Hz/cell. The impact of the radio resource management algorithms on performance is discussed in Chapter 8.

9.6.1 System Deployment Scenarios

The specified LTA evaluation and test scenarios correspond to various radio propagation conditions and environments, similarly to HSPA [4]. The assumed macro and micro scenarios are shown in Table 9.13 and Table 9.14, and both assume a hexagonal-grid cellular layout.

Table 9.9 Downlink link budget parameters for LTE

Field	Description	Typical value
a	Base station maximum transmission power. A typical value for macro cell base station is 20–60 W at the antenna connector.	43–48 dBm
b	Base station antenna gain. See uplink link budget.	
c	Cable loss between the base station antenna connector and the antenna. The cable loss value depends on the cable length, cable thickness and frequency band. Many installations today use RF heads where the power amplifiers are close to the antenna making the cable loss very small.	1–6 dB
d	Calculated as $A + B - C$	
e	UE RF noise figure. Depends on the frequency band, Duplex separation and on the allocated bandwidth. For details, see Chapter 12.	6–11 dB
f	Terminal noise can be calculated as k (Boltzmann constant) $\times T$ (290K) \times bandwidth. The bandwidth depends on bit rate, which defines the number of resource blocks. We assume 50 resource blocks, equal to 9 MHz, transmission for 1 Mbps downlink.	–104.5 dBm for 50 resource blocks (9 MHz)
g	Calculated as $E + F$	
h	Signal-to-noise ratio from link simulations or measurements. The value depends on the modulation and coding schemes, which again depend on the data rate and on the number of resource blocks allocated.	–9 dB for 1 Mbps and 50 resource blocks
i	Calculated as $G + H$	
j	Interference margin accounts for the increase in the terminal noise level caused by the other cell. If we assume a minimum G-factor of –4 dB, that corresponds to $10 \times \log_{10}(1 + 10^{(4/10)}) = 5.5$ dB interference margin.	3–8 dB
k	Control channel overhead includes the overhead from reference signals, PBCH, PDCCH and PHICH.	10–25% = 0.4–1.0 dB
l	UE antenna gain. See uplink link budget.	–5–10 dBi
m	Body loss. See uplink link budget.	3.5 dB for voice

The typical evaluation scenarios used for LTE are macro case 1 and macro case 3 with 10 MHz bandwidth and low UE mobility. The propagation models for macro cell scenario are based on the Okamura–Hata model presented in section 9.5.

The micro cell scenarios assume an outdoor base station location and an outdoor and/or indoor mobile station location. The propagation model for these micro cell scenarios is similar to the macro cell models, but with different parameter settings, specific to the dense urban deployment scenario. The assumed micro cell base station antenna configuration is omni-directional (one-sector) as opposed to the directional (three sectors) deployments for macro cell scenarios. For the micro cell outdoor-to-outdoor scenario a dual-slope distance dependent path loss model is used in order to account for the Line-of-Sight (LOS) and Non-Line-of-Sight (NLOS) propagation conditions. For the micro cell outdoor-to-indoor scenario a single-slope distance dependent path loss model is used with a higher path loss exponent compared to the macro cell Okamura–Hata and micro cell outdoor-to-outdoor models. Typically, for system evaluation both outdoor and indoor mobile stations are assumed simultaneously with a 50:50 distribution ratio.

Table 9.10 Downlink link budgets

Downlink		GSM voice	HSPA	LTE
Data rate (kbps)		12.2	1024	1024
Transmitter – Node B				
a	Tx power (dBm)	44.5	46.0	46.0
b	Tx antenna gain (dBi)	18.0	18.0	18.0
c	Cable loss (dB)	2.0	2.0	2.0
d	EIRP (dBm)	60.5	62.0	62.0
Receiver – UE				
e	UE noise figure (dB)	–	7.0	7.0
f	Thermal noise (dB)	–119.7	–108.2	–104.5
g	Receiver noise floor (dBm)	–	–101.2	–97.5
h	SINR (dB)	–	–5.2	–9.0
i	Receiver sensitivity (dBm)	–104.0	–106.4	–106.5
j	Interference margin (dB)	0.0	4.0	4.0
k	Control channel overhead (%)	0.0	20.0	20.0
l	Rx antenna gain (dBi)	0.0	0.0	0.0
m	Body loss (dB)	3.0	0.0	0.0
Maximum path loss		161.5	163.4	163.5

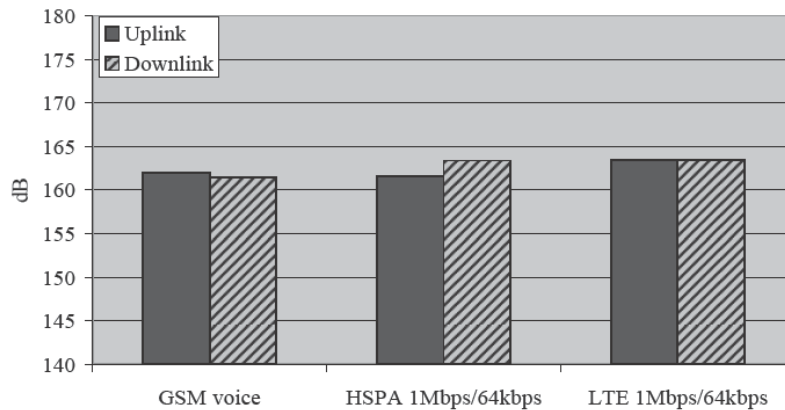
**Figure 9.6** Maximum path loss values for GSM voice and HSPA and LTE data

The differences between the reference system deployment cases, as expected, yield different system performances. Generally, the macro cell scenarios provide the baseline LTE system performance numbers, while the special deployment cases, such as the micro cell

Table 9.11 Benefit of 900 MHz compared to 2600 MHz

	Urban	Rural	Rural fixed wireless
Propagation loss ^a	+14 dB	+14 dB	+14 dB
BTS antenna gain	-3 dB ^b	0 dB ^c	0 dB ^c
BTS cable loss ^d	+1 dB	+3 dB	+3 dB
UE antenna gain	-5 dB ^e	-5 dB ^e	0 dB ^f
UE sensitivity ^g	-1 dB	-1 dB	-1 dB
Total	+6 dB	+11 dB	+16 dB

^aAccording to Okumura–Hata.

^bShared 1.3 m antenna for 900/2600 giving 15 and 18 dBi gain at 900 vs 2600 MHz.

^c2.5 m antenna giving 18 dBi gain at 900 MHz.

^dCable 1/2'. Urban 30 m and rural 100 m.

^eBased on 3GPP RAN4 contributions.

^fExternal fixed antenna assumed.

^gUE sensitivity can be up to 3 dB worse at 900 MHz but the difference in practice is less.

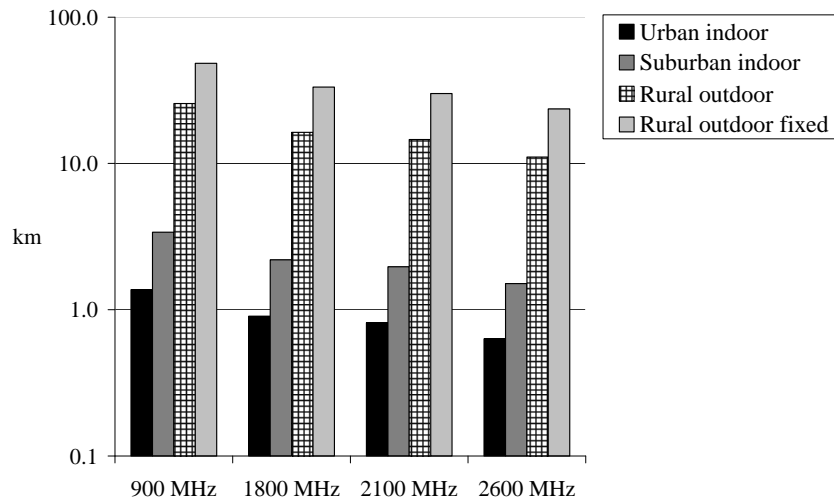
**Figure 9.7** Cell ranges with Okumura–Hata propagation model

scenario, are used for the evaluation of adaptive spatial multiplexing MIMO enhancement techniques, which are able to better exploit the high Signal-to-Interference-and-Noise (SINR) conditions.

The results with Spatial Channel Model in Urban macro (SCM-C) radio channels and with a mixed velocity are also shown, as defined in reference [5].

The main simulation assumptions are shown in Table 9.15.

Table 9.12 Parameters for Okumura–Hata propagation model

	Urban indoor	Suburban indoor	Rural outdoor	Rural outdoor fixed
Base station antenna height (m)	30	50	80	80
Mobile antenna height (m)	1.5	1.5	1.5	5
Mobile antenna gain (dBi)	0.0	0.0	0.0	0.0
Slow fading standard deviation (dB)	8.0	8.0	8.0	8.0
Location probability	95%	95%	95%	95%
Correction factor (dB)	0	-5	-15	-15
Indoor loss (dB)	20	15	0	0
Slow fading margin (dB)	8.8	8.8	8.8	8.8
Max path loss at 1800/2100/2600 (dB)	163	163	163	163
Max path loss at 900 (dB)	160	160	160	160

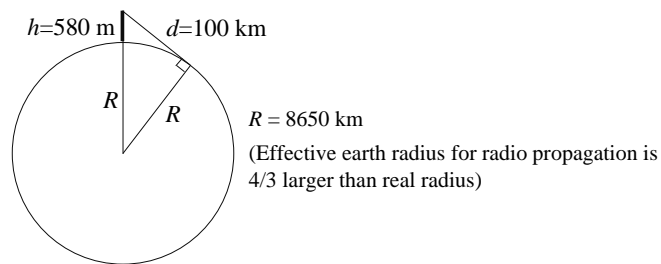
**Figure 9.8** Maximum cell range limitation caused by earth curvature**Table 9.13** LTE reference system deployment cases – macro cell scenarios

Simulation cases (macro)	Frequency (GHz)	Inter-site distance (m)	Bandwidth (MHz)	UE Speed (kmph)	Penetration loss (dB)
1	2.0	500	10	3	20
3	2.0	1732	10	3	20

Table 9.14 LTE reference system deployment cases – micro cell scenarios. The indoor:outdoor UE location ratio used is 50:50

Simulation cases (micro)	Frequency (GHz)	Inter-site distance (m)	Bandwidth (MHz)	UE Speed (kmph)	Penetration loss (dB)
Outdoor-to-outdoor	2.0	130	10	3	0
Outdoor-to-indoor	2.0	130	10	3	Included in the path loss model

9.6.2 Downlink System Performance

As a typical comparison between the different deployment environments, Figure 9.9 shows the distribution of the average wideband channel SINR also known as Geometry factor or G-factor.

Table 9.15 Simulation assumptions for simulation scenarios

Description	Settings
Number of active UEs per cell	10 UEs, uniformly distributed
Bandwidth	10 MHz
Channel	3GPP TU at 3 km/h (6 tap) SCM-C at 3 km/h and with correlations for spatial channels ITU modified Pedestrian B and Vehicular A with correlation Mixed velocity case: – 60% of UEs with ITU modified Pedestrian B at 3 km/h, – 30% of UEs with ITU modified Vehicular A at 30 km/h and – 10% of UEs with ITU modified Vehicular A at 120 km/h
Cell selection	Best cell selected with 0 dB margin
Transmission power	Uplink: Max 24 dBm (latest 3GPP specifications use 23 dBm)
Antenna configuration	Downlink: 1 × 2, 2 × 2 Uplink: 1 × 2, 1 × 4
Receiver algorithms	Downlink: LMMSE (Linear Minimum Mean Square Error) receiver Uplink: LMMSE receiver with Maximal Ratio Combining

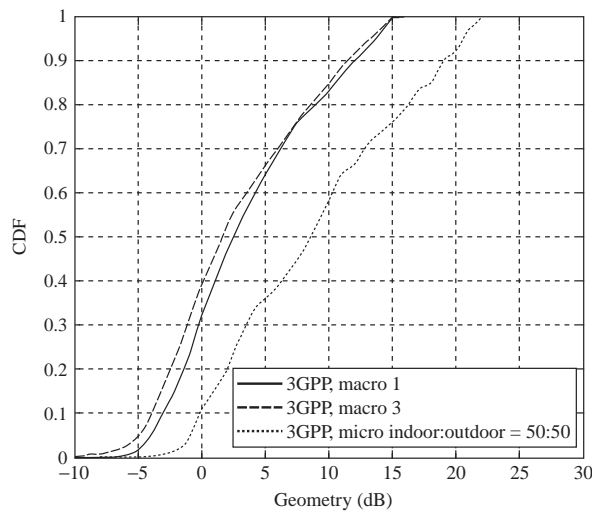
**Figure 9.9** Distribution of the average wide-band channel SINR (geometry factor) macro case 1, case 3 and micro

The corresponding downlink system performance numbers for LTE SIMO and 2 × 2 MIMO transmission schemes are presented in Figure 9.10 and Figure 9.11, respectively.

Macro scenarios have median G-factors of 2–3 dB while the micro scenario has a G-factor above 8 dB. The macro cell has practically no values above 15 dB while the micro cell has 25% of the samples above 15 dB. The higher G-factor in micro cells turns into a higher throughput compared to the macro cells.

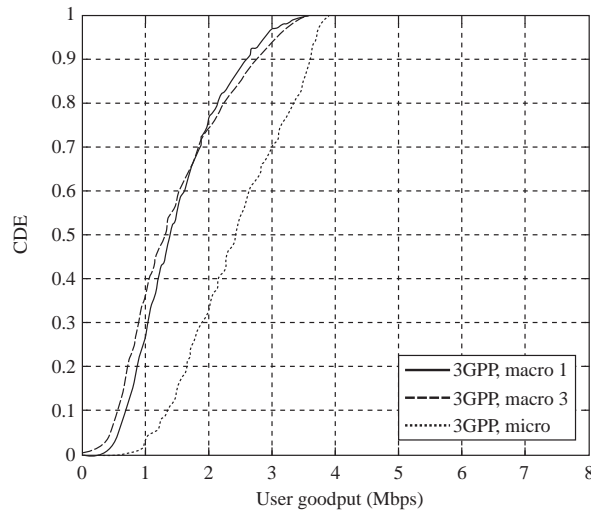

Figure 9.10 Downlink user throughput distribution simulation results in macro case 1, case 3 and micro test deployment scenarios for LTE 1×2 SIMO transmission scheme

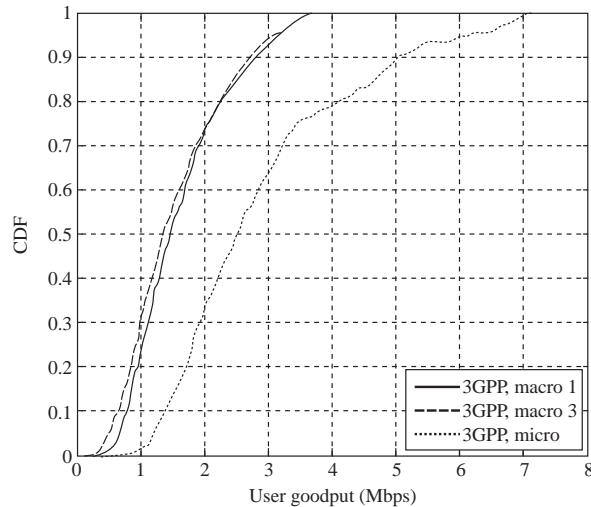

Figure 9.11 Downlink user throughput distribution simulation results in the macro case 1, case 3 and micro test deployment scenarios for LTE 2×2 MIMO transmission scheme

Figure 9.10 shows the user throughput with 10 users without MIMO. The median macro cell throughput is 1.4 Mbps while the micro cell provides 2.5 Mbps. The maximum values are 3–4 Mbps. Figure 9.11 presents the same case but with 2×2 MIMO. The median data rates are similar to the non-MIMO case but the highest data rates in micro cells are increased from 4 Mbps to 7 Mbps.

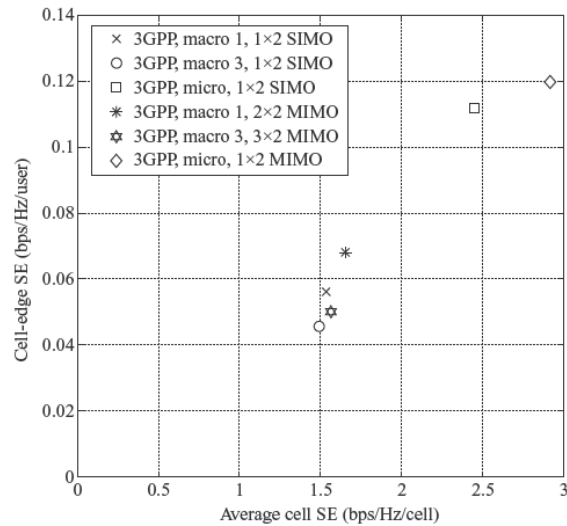

Figure 9.12 Downlink average cell and cell-edge spectral efficiency simulation results in the macro case 1, case 3 and micro test deployment scenarios for LTE 1×2 SIMO and 2×2 MIMO transmission scheme

Figure 9.12 shows the summary of the average cell spectral efficiency (SE) and the cell edge efficiency. Micro cell scenarios show considerably higher efficiency than macro scenarios. MIMO increases the average efficiency in micro cells but provides only marginal gains in the macro cell environment.

9.6.3 Uplink System Performance

Uplink baseline results with Best Effort data are shown for a two and four antenna receiver with Round Robin (RR) and Proportional Fair (PF) schedulers. In these results Interference over Thermal (IoT) probability at 20dB was limited to 5%.

Figure 9.13 shows cell throughput for two types of scenarios for Inter-Site Distances (ISD) of 500m and 1500m. The cell throughput is presented with full Sounding Reference Signal (SRS) usage, thus giving a lower bound of system performance. From these results the PF scheduler gives about a 15–20% gain for mean cell throughput over the RR scheduler. Most of this gain comes from using SRS for better frequency domain scheduling. With higher UE speeds (e.g. 120km/h) this gain will decrease towards the corresponding RR scheduler results. Furthermore, the cell edge throughput with the same cell mean throughput is about 125% higher in ISD 500m than in a larger cell size. UE power limitation is seen at ISD 1500m with lower cell edge performance. Note that the impact of the cell size is larger in uplink than in downlink due to the lower UE power compared to the eNodeB transmission power.

The 95% limit for IoT distribution is set to 20dB. Smaller cell sizes like ISD 500m are affected by this constraint because higher IoT values would be possible from the UE power

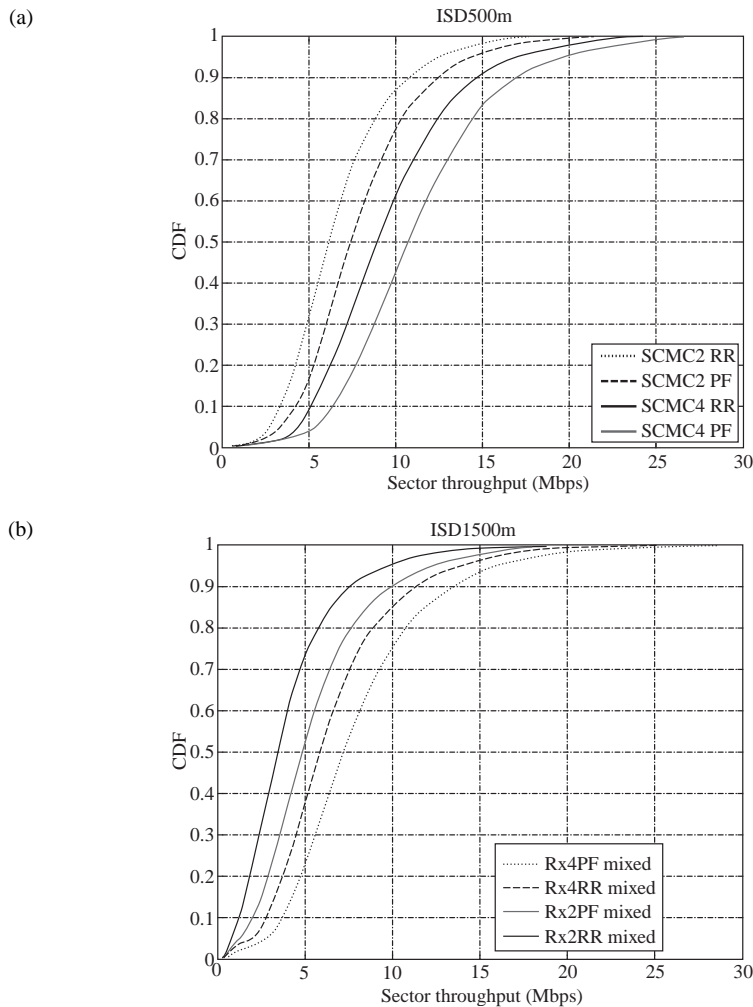

Figure 9.13 Uplink cell throughput for (a) ISD 500 m; (b) ISD 1500 m

point of view. The mean IoT is 13 dB in Figure 9.14. For a larger cell size (like ISD 1500m) IoT is not a limiting factor and the mean IoT is 2 dB.

The uplink power control range in ISD 500 m is seen in Figure 9.15. The power control range can be used well at a smaller cell size. The median UE transmission power is 15 dBm. This power is relatively high compared to voice users, but it is expected for the data connection. In a larger cell a higher proportion of users are limited by maximum power, thus moving the remaining distribution towards the right side.

Some spectral efficiency figures are collected into Table 9.16 for comparison with HSUPA. From these figures we observe that uplink performance is doubled from the cell mean spectral

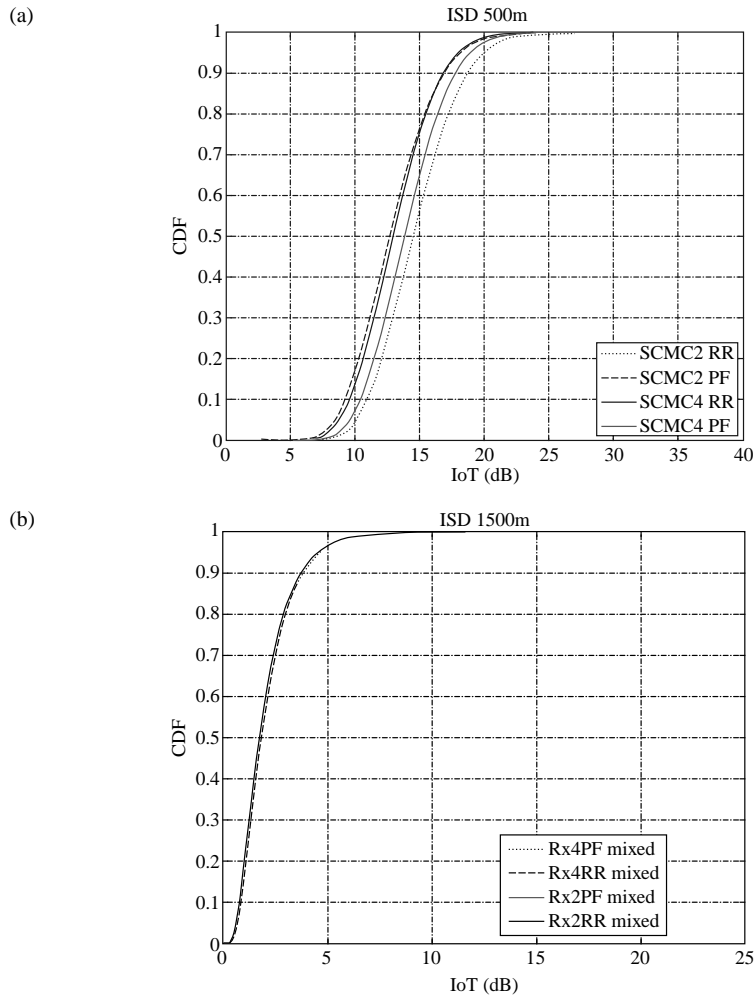

Figure 9.14 Uplink instantaneous Noise Raise for (a) ISD 500m; (b) ISD 1500m

efficiency point of view with RR scheduler and 2-branch reception. Furthermore, at the same time cell edge performance is tripled. With PF and 4-branch reception, the gain over HSUPA can be further improved.

The average spectral efficiency in different channel models and cell sizes is summarized in Figure 9.16 and the cell edge efficiency in Figure 9.17. The efficiency is higher in small cells than in large cells since the UE runs out of power in large cells. The impact of the cell size is most clearly visible in cell edge efficiency. We can also see that 4-branch reception and PF scheduling provide higher capacity compared to 2-branch reception and RR scheduling.

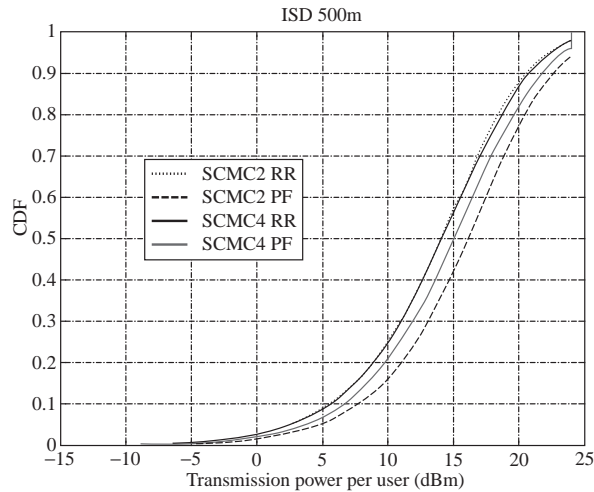

Figure 9.15 Uplink transmission power CDF per user in case of ISD 500 m

Table 9.16 Uplink spectral efficiency at the mean and at the cell edge for various multi-antenna configurations, FDE/MRC receivers and RR/PF schedulers

Best effort traffic		
Features	Spectral efficiency cell mean (b/s/Hz/cell)	Spectral efficiency cell edge (5%-ile) (b/s/Hz/cell)
HSUPA	0.33	0.009
1×2 RR	0.66	0.027
1×2 PF	0.79	0.033
1×4 RR	0.95	0.044
1×4 PF	1.12	0.053

9.6.4 Multi-antenna MIMO Evolution Beyond 2×2

The downlink LTE MIMO transmission schemes are specified to support up to a four transmit antenna port configuration. A brief summary of these schemes is given in Table 9.17, along with the employed terminology.

The MIMO rank identifies the number of spatial layers (streams) while the MIMO codeword is used to jointly encode up to two spatial layers. In this context the closed-loop MIMO operation is implemented using codebook based pre-coding, i.e. the antenna weights (vectors or matrices) to be applied at the base station side are selected from a fixed number of possibilities, which form a quantized codebook set. These codebook sizes are summarized in Table 9.17. Furthermore, for all the single-user spatial multiplexing MIMO schemes it is assumed that the multiplexed spatial layers are transmitted to the same mobile station.

In a practical system, to ensure proper performance of these MIMO schemes, the overall radio Layer 1 (L1) and Layer 2 (L2) resource management has to include a minimum set of

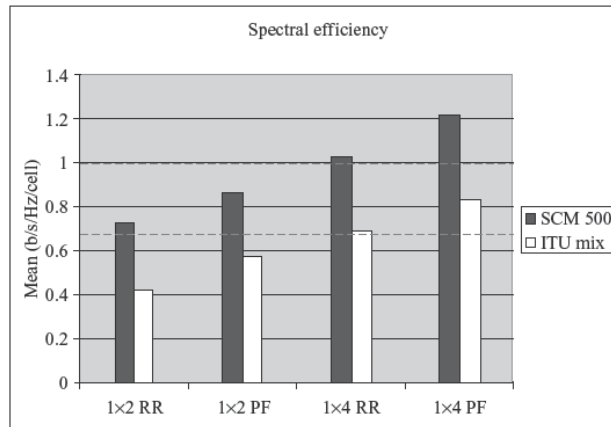

Figure 9.16 Uplink mean spectral efficiency

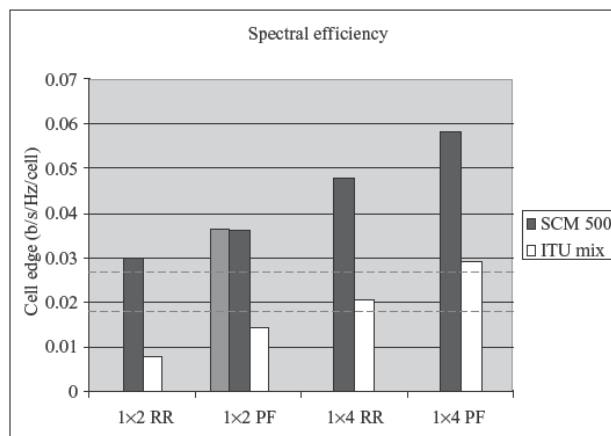

Figure 9.17 Uplink cell edge spectral efficiency

Table 9.17 LTE specification for downlink single-user MIMO transmission schemes. MIMO precoding codebook size and codeword transmission modes

MIMO scheme	Rank 1 (1 layer)	Rank 2 (2 layers)	Rank 3 (3 layers)	Rank 4 (4 layers)	Codeword transmission mode
2x1	4 vectors	No	No	No	Single codeword
2x2	4 vectors	3 matrices	No	No	Rank 2 with dual codeword
4x2	16 vectors	16 matrices	No	No	Rank 2 with dual codeword
4x4	16 vectors	16 matrices	16 matrices	16 matrices	Rank 2–4 with dual codeword

MIMO-aware mechanisms at both eNodeB and UE side. The minimum set of required feedback information from the UE to support downlink adaptive spatial multiplexing MIMO transmission comprises:

- channel state/quality information (CQI): direct (e.g. SINR) or indirect (e.g. MCS) information on the average channel conditions estimated on the physical resources and MIMO codewords;
- MIMO rank information: indicates the optimum number of spatial layers (streams) to be used and the corresponding pre-coding vector/matrix index (PMI);
- HARQ information: indicates the reception status (ACKnowledged/Not ACKnowledged) of the transmitted data packets on the scheduled MIMO spatial layers.

The first two items above, CQI and PMI, are estimated by the mobile station based on the downlink pilot measurements and are transmitted back to the base station in a quantized form. The HARQ mechanism has an impact on the freedom of the radio resource management blocks, when link adaptation and optimized packet scheduling has to be performed for single/dual codeword MIMO transmission.

The mobile station feedback information is heavily dependent on the channel/signal estimation performance, which has an upper bound due to the practical system design limitations (reference signals, measurement/estimation time, propagation delays, etc.). Furthermore, all this feedback information requires uplink control channel capacity; thus it is desirable to minimize the actual number of information bits used to encode them and converge to a practical tradeoff between the achievable MIMO performance and the required uplink capacity.

The system level performance degradation due to limited and noisy feedback from the terminals has been studied and presented in the literature under practical LTE-like assumptions, e.g. [6, 7]. In the following the main concepts related to these performance tradeoffs in simple reference MIMO configuration cases are summarized. The radio resource management aspects are discussed in more detail in Chapter 8.

In theory, the optimal link adaptation operation with spatial-multiplexing MIMO schemes requires separate CQI measures estimated for each separately encoded spatial layer. Without significant loss of performance the CQI feedback has been reduced by grouping the spatial layers into two groups with a maximum of two layers each, so that two CQI measures are sufficient for the considered MIMO transmission schemes. Each group of spatial layers is separately encoded and corresponds to one codeword (see Table 9.17).

The optimized operation of the adaptive MIMO transmission schemes requires, in addition to the classical link adaptation, a MIMO rank adaptation mechanism. A straightforward and simple scheme is with the optimum MIMO rank selected at the terminal side such that it maximizes the instantaneous downlink user throughput. The optimum pre-coding vector/matrix can be determined based on various criteria: maximum beam-forming gain, maximum SINR or maximum throughput. For simplicity, here we use the first criterion because this implies the computation of signal power levels only. The latter options are more complex and require information about the number of allocated physical resources blocks, the interference levels and the modulation and coding used.

Based on the instantaneous channel conditions the terminal estimates the optimum MIMO rank, and the corresponding optimum pre-coding vector/matrix. Ideally, both the MIMO rank and the PMI should be estimated for each physical resource block, i.e. assuming frequency-selective MIMO adaptation. For large system bandwidths of 5 MHz and above, in practice this approach leads to a

very large signaling overhead introduced in the uplink control channel. A good compromise can be achieved by using MIMO feedback per group of several consecutive physical resource blocks. This approach is further motivated by the choice made for the CQI feedback in the LTE systems. The CQI feedback is described in Chapter 5. The MIMO feedback information is assumed to be transmitted to the serving base station together with, or embedded in, the CQI reports.

In the context of the LTE system, because the same modulation and coding scheme is used on all the allocated physical resource blocks, it is also reasonable to assume that the same MIMO rank can be used for all the allocated physical resource blocks. Furthermore, given that the actual resource allocation is determined by the packet scheduler at the base station, and not at the terminal side, a practical solution is to use one single MIMO rank determined for the entire monitored system bandwidth, i.e. frequency non-selective MIMO rank information is fed back to the base station.

The minimal system-level restrictions described above, still allow for quite a large degree of freedom in the MIMO adaptation mechanisms, in both the time and frequency domains. Some relevant examples are presented in the following.

The frequency granularity of the PMI feedback can be different from the granularity of the MIMO rank. Two reference PMI selection schemes can be assumed combined with the above described full-bandwidth MIMO rank selection:

- Frequency Non-Selective (FNS) PMI: one PMI is determined for the entire effective system bandwidth;
- Frequency Selective (FS) PMI: one PMI is determined for each group of two consecutive physical resource blocks, i.e. using the same $2 \times \text{PRB}$ granularity as the CQI measures.

Using the MIMO and CQI feedback information from all the active terminals in the serving cell, the RRM algorithm in the serving base station performs the actual resource allocation and scheduling for each terminal. Previous investigations with low mobility scenarios have disclosed the influence on the overall system performance of the rate at which the MIMO adaptation is performed. The results show that a semi-adaptive scheme with slow update rate (~ 100 ms) based on the average channel conditions yields only small cell throughput losses of the order of 5% compared to the case with a fast-adaptive scheme with MIMO rank selected in each scheduling period. Thus, there are two reference schemes:

- G-factor based (GF): with rank update based on the average wideband channel SINR conditions;
- quasi-dynamic (QD): with rank selected only when a new (1st HARQ) transmission is scheduled.

The quasi-dynamic MIMO scheme is a tradeoff solution between the fast-adaptive (per TTI) and the G-factor based (slow, per 5 ms to 10 ms) adaptation schemes, thus it can be successfully used in both medium and low mobility scenarios.

In combination with these two L1–L2 mechanisms – MIMO rank adaptation, and MIMO pre-coding information feedback frequency domain granularity – the downlink adaptive 2×2 and 4×4 MIMO transmission schemes have been simulated. These evaluations assume limited, imperfect and delayed channel feedback from the terminals. The PMI and rank information feedback is assumed to be error free, while the CQI information is modeled with errors introduced by the channel estimation.

Figure 9.18 and Figure 9.19 show representative simulation results for the spectral efficiency in the macro cell case 1 and micro cell deployment scenarios (see section 9.6.1), respectively. The number of mobile stations is 20 simulated per cell/sector. Time–frequency proportional fair packet scheduling is employed.

For both the 2×2 and 4×4 MIMO transmission schemes, the macro cell investigations show gains in the average cell spectral efficiency and the cell-edge spectral efficiency of the order of 10% and 18%, respectively, when using quasi-dynamic MIMO rank adaptation and frequency selective closed-loop information feedback compared to the G-factor based and frequency non-selective cases. The performance in micro cell scenarios is less impacted, with gains of up to 4% and 15%, respectively. The latter results confirm the suitability and high potential of the downlink MIMO schemes in microcellular environments without introducing significant overhead in the uplink signaling and control channels payload.

9.6.5 Higher Order Sectorization (Six Sectors)

One of the methods for increasing the performance by using more antennas at the base station is to use higher order sectorization. The use of higher order sectorization is especially considered to be an option for macro cell installations, where antennas are mounted above rooftops. Typically, three-sector sites are assumed in most of the LTE macro cell performance evaluations, by using three separate panel antennas per site, each with a 3 dB beamwidth of 65 or 70 degrees. A first step could therefore be to increase the sectorization to six sectors per site by simply using six panel antennas with a narrower beamwidth of, for example, 35 degrees. This provides a simple method for increasing the capacity of the network at the sites with high offered traffic. The six sector antennas could also be implemented with three panel antennas and digital fixed beamforming.

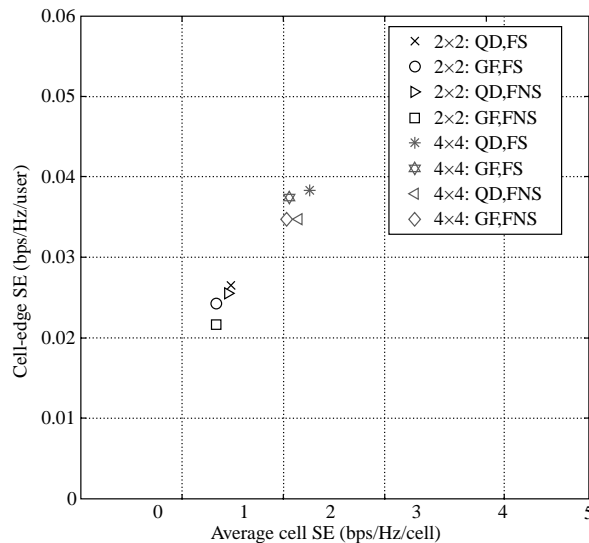

Figure 9.18 Average cell vs cell-edge user (coverage) spectral efficiency simulation results for MIMO schemes operating in the macro cell case 1 scenario

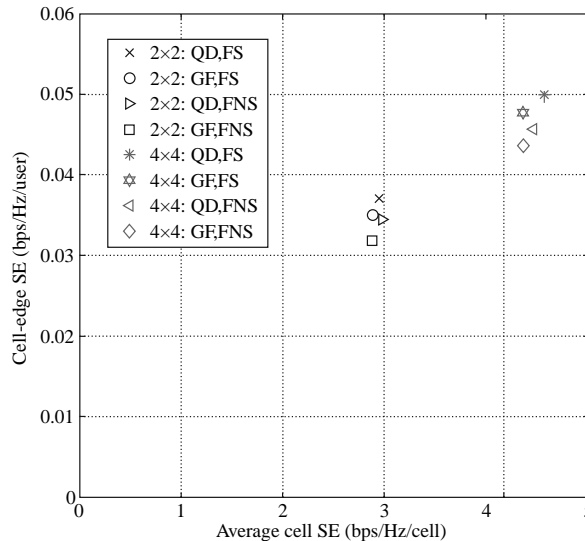

Figure 9.19 Average cell vs cell-edge user (coverage) spectral efficiency simulation results for MIMO schemes operating in the micro cell scenario

The performance improvements of six sectors vs three sectors have been evaluated by means of system simulations in a typical macro cell environment with 500 m site-to-site distance, i.e. similar to 3GPP macro cell case 1 with LTE 10 MHz bandwidth. The following four cases are considered:

- all sites have three sectors with antenna beamwidth of 70 degrees;
- all sites have six sectors with antenna beamwidth of 35 degrees;
- only one centre site has six sectors, while other sites have three sectors (denoted Mode-1);
- a cluster of seven sites has six sectors, while all other sites have three sectors (denoted Mode-2).

Performance results for these four cases are presented in Figure 9.20, where the average throughput per site is reported. These results were obtained with a simple full buffer traffic model, assuming two antennas at the terminals, and standard proportional fair time-frequency packet scheduling. A significant performance gain is achieved by increasing the sectorization from three sectors to six sectors: the site capacity is increased by 88%. If only one site is upgraded to have six sectors (Mode-1), then the capacity of that particular site is increased by 98% compared to using three sectors. The latter result demonstrates that upgrading sites to using higher order sectorization is a possible solution for solving potential capacity bottlenecks that may arise in certain hotspot areas. Assuming that the number of users per site is the same, independent of whether three sectors or six sectors are used, then similar improvements are found in terms of user experienced throughput. However, the use of higher order sectorization does not increase the peak user throughput as is the case for the use of MIMO schemes. Similar

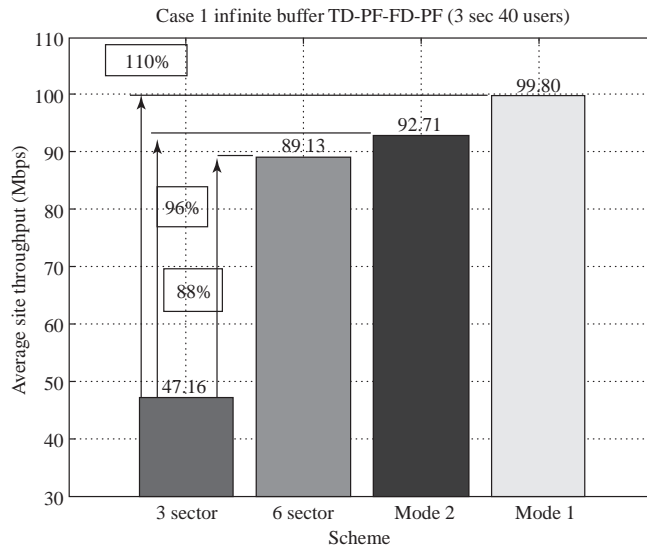

Figure 9.20 Average throughput per macro cell site for different sectorization configurations [8].
© 2008 IEEE

capacity gains of six sectors vs three sectors have also been reported in [9] for WCDMA networks. The simulated capacity has considered the downlink direction. It is expected that the gains are also similar in the uplink direction.

The impact of the beamwidth with a six-sector antenna was also studied and the results are shown in Figure 9.21. The motivation for presenting these results is that even though the raw antenna beamwidth is 35 degrees, the effective antenna beamwidth is larger due to the radio channels' azimuthal dispersion [10]. The azimuthal dispersion is found to be of the order of 5–10 degrees for typical urban macro cells. The simulation results show that the average site throughput with antenna beamwidth of 40 degrees is 1% lower compared to 35 degrees, and with 45 degrees it is 4% lower.

The six-sector deployment also improves the network coverage since the typical antenna gain is increased from 18 dBi in three-sector 70-degree antennas to 21 dBi in six-sector 35-degree antennas.

9.6.6 Spectral Efficiency as a Function of LTE Bandwidth

Most LTE system simulations assume 10 MHz bandwidth. The system bandwidth has some impact on the efficiency mainly due to the following factors:

- The frequency domain scheduling gain is higher with larger bandwidth since there is more freedom for the scheduler to optimize the transmission. For 1.4 MHz bandwidth the frequency domain scheduling gain is very low since the whole channel bandwidth likely has flat fading.
- The relative overhead from common channels and control channel – PBCH, Synchronization signal and PUCCH – is lower with larger bandwidths.

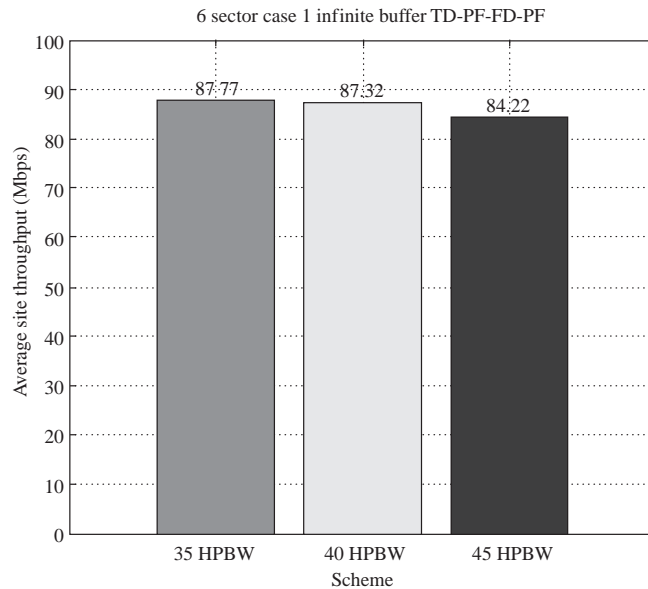

Figure 9.21 Comparison of site throughput for different degrees of azimuth spread for six-sector-site deployment. © 2008 IEEE

- The relative guard band is higher with a 1.4 MHz bandwidth: six resource blocks at 180 kHz equal to 1.08 MHz corresponding to 77% utilization compared to the channel spacing of 1.4 MHz. The utilization is 90% for other bandwidths.

The calculations for the relative efficiency of the bandwidths are shown in Table 9.18 for downlink and in Table 9.19 for uplink. The frequency domain scheduling gain depends on several factors including environment, mobile speed, services and antenna structure. We assume that the scheduling gain in uplink is half of the downlink gain for all bandwidths.

The results are summarized in Figure 9.22. The efficiency is quite similar for the bandwidths of 5 to 20 MHz while there is a 15% difference for 3 MHz. The efficiency with 1.4 MHz bandwidth is approximately 35–40% lower than for 10 MHz. The typical downlink cell throughput

Table 9.18 Relative efficiency of different LTE bandwidths in downlink

	LTE 1.4 MHz	LTE 3 MHz	LTE 5 MHz	LTE 10 MHz	LTE 20 MHz
Resource blocks	6	15	25	50	100
Guard band overhead	23%	10%	10%	10%	10%
BCH overhead	2.9%	1.1%	0.7%	0.3%	0.2%
SCH overhead	2.5%	1.0%	0.6%	0.3%	0.2%
Frequency domain scheduling gain	5%	20%	35%	40%	45%

Table 9.19 Relative efficiency of different LTE bandwidths in uplink

	LTE 1.4 MHz	LTE 3 MHz	LTE 5 MHz	LTE 10 MHz	LTE 20 MHz
Guard band overhead	23%	10%	10%	10%	10%
PUCCH overhead	16.7%	13.3%	8.0%	8.0%	8.0%
Frequency domain scheduling gain	2.5%	10%	17.5%	20%	22.5%

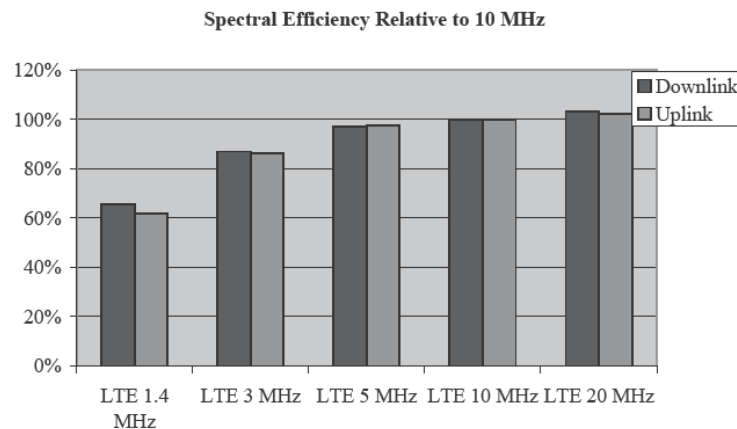
**Figure 9.22** Relative spectral efficiency compared to 10MHz bandwidth in macro cells

for 20 MHz is $1.74 \text{ bps/Hz/cell} \times 20 \text{ MHz} = 35 \text{ Mbps}$, while for 1.4 MHz the cell throughput is $1.74 \text{ bps/Hz/cell} \times 60\% \times 1.4 \text{ MHz} = 1.5 \text{ Mbps}$. The conclusion is that LTE should be deployed using as large a bandwidth as possible. The main motivation is to maximize the LTE data rates, but the second motivation is to optimize the spectral efficiency as well. The narrowband options are still useful for refarming purposes if it is not possible to allocate larger bandwidths initially. Even if LTE 1.4 MHz cell throughput of 1.5 Mbps seems relatively low, it is still more than what can be offered by narrowband 2G GPRS/EDGE networks.

9.6.7 Spectral Efficiency Evaluation in 3GPP

The LTE target was to provide spectral efficiency at least three times higher than HSDPA Release 6 in downlink and two times higher than HSUPA Release 6 in uplink. The relative efficiency was studied by system simulations in 3GPP during 2007. The results of the different company contributions are illustrated in Figure 9.23 for downlink and in Figure 9.24 for uplink. These results are for Case 1, which represents interference limited small urban macro cells. The average downlink efficiency increases from HSDPA 0.55 bps/Hz/cell to LTE 1.75 bps/Hz/cell, corresponding to three times higher efficiency. The uplink efficiencies are 0.33 for HSUPA and 0.75 for LTE, corresponding to more than two times higher efficiency. The performance

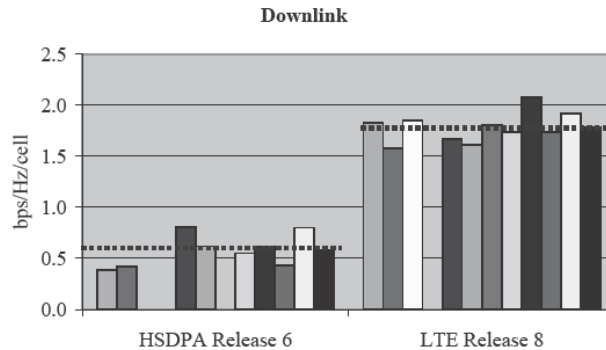

Figure 9.23 Downlink spectral efficiency results from different company contributions [11]

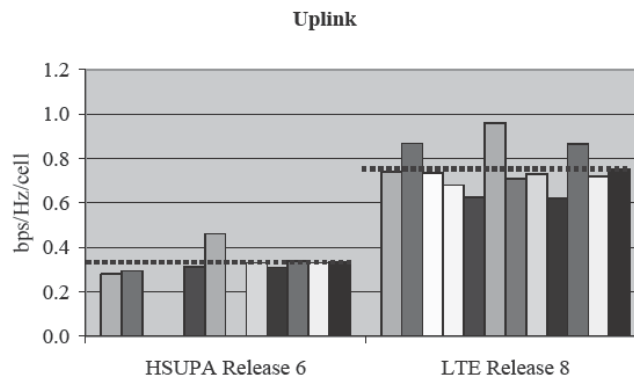

Figure 9.24 Uplink spectral efficiency results from different company contributions [12]

evaluation showed that LTE can fulfill those targets that have been defined for the system in the early phase.

HSPA Release 6 with two-antenna Rake receiver terminals was used as the reference case since it was the latest 3GPP release available at the time when LTE work started. HSPA Release 6 is based on 1×2 maximum ratio combining. LTE Release 8 uses 2×2 MIMO transmission.

9.6.8 Benchmarking LTE to HSPA

The spectral efficiency gain of LTE over HSDPA can be explained by a few characteristics in the LTE system design. Those factors are shown in Table 9.20 for the downlink. LTE uses orthogonal modulation to avoid intra-cell interference providing a major boost in capacity compared to HSDPA with Rake receiver. The CDMA transmission in HSDPA suffers from intra-cell interference caused by multi-path propagation. The CDMA codes are orthogonal but only in the single path channel. The LTE benefit over HSDPA depends on the amount of multi-path propagation.

Table 9.20 LTE downlink efficiency benefit over HSPA Release 6 in macro cells

LTE benefit	Gain	Explanation
OFDM with frequency domain equalization	Up to +70% depending on the multi-path profile	HSDPA suffers from intra-cell interference for the Rake receiver. Rake receiver is assumed in Release 6. However, most HSDPA terminals have an equalizer that removes most intra-cell interference.
Frequency domain packet scheduling	+40%	Frequency domain scheduling is possible in OFDM system, but not in single carrier HSDPA. The dual carrier HSDPA can get part of the frequency domain scheduling gain.
MIMO	+15%	No MIMO defined in HSDPA Release 6. The gain is relative to single antenna base station transmission. HSDPA Release 7 includes MIMO.
Inter-cell interference rejection combining	+10%	The interference rejection combining works better in OFDM system with long symbols.
Total difference	= 3.0×	$1.7 \times 1.4 \times 1.15 \times 1.1$

Another major benefit in LTE is the frequency domain scheduling, which is not possible in a CDMA based system. The CDMA systems transmit the signal using the full bandwidth. MIMO provides some efficiency benefit in LTE since MIMO was not included in HSDPA Release 6. The inter-cell interference rejection combining is used in LTE simulation results and it gives some further capacity boost for LTE. Adding these factors together gives the result that LTE is indeed expected to provide approximately three times higher efficiency than HSDPA Release 6. The LTE performance gain over HSDPA Release 6 will be larger in small micro or indoor cells where the multistream MIMO transmission can be used more often for taking advantage of high LTE data rates.

The LTE uplink efficiency gain over HSUPA mainly comes from the orthogonal uplink while HSUPA suffers from intra-cell interference.

HSPA evolution brings some performance enhancements to HSPA capacity; for details see Chapter 13. MIMO is part of HSPA Release 7; terminal equalizers can remove intra-cell interference in downlink and base station interference cancellation can remove intra-cell interference in uplink. Dual carrier HSDPA transmission is included in Release 8, which enables some frequency domain scheduling gain. Even if all the latest enhancements from HSPA evolution are included, LTE still shows an efficiency benefit over HSPA.

The efficiencies from system simulations are illustrated in Figure 9.25. HSPA Release 7 includes here a UE equalizer and 2×2 MIMO in downlink and base station interference cancellation in uplink. HSPA Release 8 includes dual carrier HSDPA with frequency domain packet scheduling. HSPA Release 9 is expected to allow the combination of MIMO and DC-HSDPA.

9.7 Latency

9.7.1 User Plane Latency

User plane latency is relevant for the performance of many applications. There are several applications that do not require a very high data rate, but they do require very low latency. Such