

**Table 123: Pre-defined Message Response Sets**

| Response Set ID | MDT Softkey 1 | MDT Softkey 2 | MDT Softkey 3 | MDT Softkey 4 |
|-----------------|---------------|---------------|---------------|---------------|
| 0 <sup>1</sup>  | {BLANK}       | {BLANK}       | {BLANK}       | {BLANK}       |
| 1               | Yes           | No            | Call          | {BLANK}       |
| 2               | OK            | {BLANK}       | {BLANK}       | {BLANK}       |
| 3               | OK            | Cancel        | Call          | {BLANK}       |
| 4               | Accept        | Decline       | Call          | {BLANK}       |
| 5               | {BLANK}       | {BLANK}       | {BLANK}       | {BLANK}       |
| 6               | {BLANK}       | {BLANK}       | {BLANK}       | {BLANK}       |
| 7               | {BLANK}       | {BLANK}       | {BLANK}       | {BLANK}       |

<sup>1</sup> Response Set ID indicates that no pre-defined response is required. However, a custom response set may still be defined within the message. Custom response sets may be defined by appending response set values to the message. Response set values are delimited by a "|" (vertical bar) character.

**Table 124: Send Message Response Message (7405)**

| # of bytes | Description                      | Value or Range  |
|------------|----------------------------------|---|
| 10         | Header                           |   |
| 1          | Client Request ID <sup>3</sup>   | 0x00 – 0xFF   |
| 2          | Status                           | 0x0000 = Success <sup>1</sup> ,<br>0x0001 = Service Not Available <sup>4</sup> ,<br>0x0002 = Invalid message format,<br>0x0003 = Message too long,<br>0x0004 = Invalid Tracker ID,<br>0x0005 = Invalid Response Set,<br>0x0006 = Database Access Error,<br>0x0007 = Service Temporarily Not Available,<br>0x0008 = Null Message Error,<br>0x0009 = Low Power Mode,<br>0x0010 = Out of Network |
| 3          | Message Sequence ID <sup>2</sup> | 0x000000 – 0xFFFFFFFF   |
| 2          | Data checksum                    |   |

<sup>1</sup> Success indicates that the message has been successfully queued so that it may be sent to the specified tracker(s).

<sup>2</sup> ID associated with the message being sent. When the tracker successfully acknowledges and/or responds to this message, the DMCS will receive a "Message Response and State" or a "Message Response and Reduced State" packet within a "Real-time Tracking Data Message" that contains the same Message Sequence ID.

<sup>3</sup> The ID associated with the request sent by the DMCS.

<sup>4</sup> If message was sent to a list of trackers, all trackers in the list must have message service available or this error code will be returned.

**Table 125: Send Pre-defined Message ID Message (7206)**

| # of bytes | Description                                    | Value or Range  |
|------------|--|---|
| 10         | Header   |   |
| 2          | Number of Trackers N <sub>1</sub> <sup>1</sup> | 0x0000 – 0x0800 <sup>4</sup>                                |
| 4          | Tracker ID #1                                  | 0x00000000 – 0x03FFFFFF                                     |
| ...        |  |   |
| 4          | Tracker ID #N <sub>1</sub>                     | 0x00000000 – 0x03FFFFFF                                     |
| 1          | Pre-defined Message ID                         | 0x00 – 0xFF   |
| 1          | Response Set ID <sup>2</sup>                   | 0x0000 – 0x07   |
| 1          | Timeout <sup>5</sup> (in minutes)              | 0x00 = No Timeout,<br>0x01- 0xF0 = timeout value in minutes |
| 1          | Client Request ID <sup>3</sup>                 | 0x00 – 0xFF   |
| 2          | Data Checksum                                  |   |

- <sup>1</sup> If the number of trackers is 0x0000, the Customer ID associated with the customer's login account profile is used.
- <sup>2</sup> A pre-defined response set (see Pre-defined Message Response Sets) may be selected. Trackers will respond using a response ID that indicates the response selected from the pre-defined set. This response ID is returned to the DMCS in a "Message Response and State" or a "Message Response and Reduced State" packet within a "Real-time Tracking Data Message" that contains the same Message Sequence ID.
- <sup>3</sup> The Client Request ID is assigned by the DMCS and is returned by the NDC Server in the response message.
- <sup>4</sup> Due to FM sub-carrier bandwidth limitations, messages sent to a large number of trackers may take several seconds (or minutes) to be delivered. Groups are expected to be small (around 20 – 60 trackers). However, the NDC Server uses an ID allocation scheme that allows it to communicate with a large number of trackers in its RF network if tracker group associations are known ahead of time. The DMCS is responsible to provide these tracker group associations.
- <sup>5</sup> Indicates the maximum retry timeout value. A Message Timeout message will be sent to the CCS/DMCS if the message is not acknowledged by the timeout value. If 0x00 is specified for the timeout, the message is sent until the PROTRAK system max timeout is reached.

**Table 176: Send Pre-defined Message ID Response Message (7406)**

| # of bytes | Description                      | Value or Range  |
|------------|----------------------------------|---|
| 10         | Header                           |   |
| 1          | Client Request ID <sup>3</sup>   | 0x00 – 0xFF   |
| 2          | Status                           | 0x0000 = Success <sup>1</sup> ,<br>0x0001 = Service Not Available <sup>4</sup> ,<br>0x0002 = Invalid message format,<br>0x0003 = Message too long,<br>0x0004 = Invalid Tracker ID,<br>0x0005 = Invalid Response Set,<br>0x0006 = Database Access Error,<br>0x0007 = Service Temporarily Not Available,<br>0x0009 = Low Power Mode,<br>0x0010 = Out of Network |
| 3          | Message Sequence ID <sup>2</sup> | 0x000000 – 0xFFFFFFFF   |
| 2          | Data checksum                    |   |

- <sup>1</sup> Success indicates that the message ID has been successfully queued so that it may be sent to the specified tracker(s).
- <sup>2</sup> ID associated with the message being sent. When the tracker successfully acknowledges and/or responds to this message, the DMCS will receive a "Message Response and State" or a "Message Response and Reduced State" packet within a "Real-time Tracking Data Message" that contains the same Message Sequence ID.
- <sup>3</sup> The ID associated with the request sent by the DMCS.
- <sup>4</sup> If pre-defined was sent to a list of trackers, all trackers in the list must have message service available or this error code will be returned.

| # of bytes           | Description                           | Value or Range  |
|----------------------|---------------------------------------|---|
| 10                   | Header                                |   |
| 2                    | Number of Trackers $N_1$ <sup>1</sup> | 0x0000 – 0x0800   |
| 4                    | Tracker ID #1                         | 0x00000000 – 0x03FFFFFF                                     |
| ...                  |                                       |   |
| 4                    | Tracker ID # $N_1$                    | 0x00000000 – 0x03FFFFFF                                     |
| 1                    | Site Expiration <sup>7</sup>          | 0x00 (all trips), 0x01 – 0xff                               |
| 1                    | Response Set ID <sup>2</sup>          | 0x0000 – 0x07   |
| 4                    | Northeast Latitude                    |   |
| 4                    | Northeast Longitude                   |   |
| 4                    | Southwest Latitude                    |   |
| 4                    | Southwest Longitude                   |   |
| 1                    | Message Length ( $L_i$ )              | 0x00 – 0x64   |
| $L_i$                | Message <sup>7</sup>                  |   |
| 1                    | Timeout <sup>5</sup> (in minutes)     | 0x00 = No Timeout,<br>0x01- 0xF0 = timeout value in minutes |
| 1                    | Client Request ID <sup>3</sup>        | 0x00 – 0xFF   |
| Padding <sup>4</sup> |                                       |   |
| 2                    | Data Checksum                         |   |

<sup>1</sup> If the number of trackers is 0x0000, the Customer ID associated with the customer's login account profile is used.  
<sup>2</sup> A pre-defined response set (see Pre-defined Message Response Sets) may be selected. Trackers will respond using a response ID that indicates the response selected from the pre-defined set. This response ID is returned to the DMCS in a "Message Response and State" or a "Message Response and Reduced State" packet within a "Real-time Tracking Data Message" that contains the same Message Sequence ID.  
<sup>3</sup> The Client Request ID is assigned by the DMCS and is returned by the NDC Server in the response message.  
<sup>4</sup> 0x00 will be used for padding if necessary to make entire body word aligned.  
<sup>5</sup> Indicates the maximum retry timeout value. A Message Timeout message will be sent to the CCS/DMCS if the message is not acknowledged by the timeout value. If 0x00 is specified for the timeout, the message is sent until the PROTRAK system max timeout is reached.  
<sup>6</sup> Site duration indicates how long a specified site should be used. Single trip indicates that the tracker should retain the site information until the tracker enters and leaves the specified site. Every trip indicates that the tracker should indicate every time the tracker enters or leaves the specified site.  
<sup>7</sup> Indicates the number of hours that the site is valid.

Table 12.B: Send Site Dispatch Response Message (7497)

| # of bytes | Description                    | Value or Range  |
|------------|--------------------------------|---|
| 10         | Header                         |   |
| 1          | Client Request ID <sup>3</sup> | 0x00 – 0xFF   |
| 2          | Status                         | 0x0000 = Success <sup>1</sup> ,<br>0x0001 = Service Not Available,<br>0x0002 = Invalid message format,<br>0x0003 = Message too long,<br>0x0004 = Invalid Tracker ID,<br>0x0005 = Invalid Response Set,<br>0x0006 = Database Access Error,<br>0x0007 = Service Temporarily Not Available,<br>0x0009 = Low Power Mode,<br>0x0010 = Out of Network |
| 1          | Site ID <sup>2,4</sup>         | 0x000000 – 0xFFFFFFFF   |
| 2          | Data checksum                  |   |

<sup>1</sup> Success indicates that the message ID has been successfully queued so that it may be sent to the specified tracker(s).  
<sup>2</sup> ID associated with the message being sent. When the tracker successfully acknowledges and/or responds to this message, the DMCS will receive a "Message Response and State" or a "Message Response and Reduced State" packet within a "Real-time Tracking Data Message" that contains the same Site ID.  
<sup>3</sup> The ID associated with the request sent by the DMCS.

**Table 129: Send User Data Message (7208)**

| # of bytes           | Description                           | Value or Range  |
|----------------------|---------------------------------------|---|
| 10                   | Header                                |   |
| 2                    | Number of Trackers $N_1$ <sup>1</sup> | 0x0000 – 0x0800 <sup>4</sup>                                |
| 4                    | Tracker ID #1                         | 0x00000000 – 0x03FFFFFF                                     |
| ...                  |                                       |   |
| 4                    | Tracker ID # $N_1$                    | 0x00000000 – 0x03FFFFFF                                     |
| 1                    | User Data Type                        | 0x00 – 0xFF   |
| 2                    | User Data Length ( $L_1$ )            | 0x0000 – 0x0050   |
| $L_1$                | User Data                             |   |
| 1                    | Timeout <sup>5</sup> (in minutes)     | 0x00 = No Timeout,<br>0x01- 0xF0 = timeout value in minutes |
| 1                    | Client Request ID <sup>3</sup>        | 0x00 – 0xFF   |
| Padding <sup>2</sup> |                                       |   |
| 2                    | Data Checksum                         |   |

<sup>1</sup> If the number of trackers is 0x0000, the Customer ID associated with the customer's login account profile is used.  
<sup>2</sup> 0x00 will be used for padding if necessary to make entire body word aligned.  
<sup>3</sup> The Client Request ID is assigned by the DMCS and is returned by the NDC Server in the response message.  
<sup>4</sup> Due to FM sub-carrier bandwidth limitations, messages sent to a large number of trackers may take several seconds (or minutes) to be delivered. Groups are expected to be small (around 20 – 60 trackers). However, the NDC Server uses an ID allocation scheme that allows it to communicate with a large number of trackers in its RF network if tracker group associations are known ahead of time. The DMCS is responsible to provide these tracker group associations.  
<sup>5</sup> Indicates the maximum retry timeout value. A Message Timeout message will be sent to the CCS/DMCS if the message is not acknowledged by the timeout value. If 0x00 is specified for the timeout, the message is sent until the PROTRAK system max timeout is reached.

**Table 130: Send User Data Response Message (7408)**

| # of bytes | Description                      | Value or Range  |
|------------|----------------------------------|---|
| 10         | Header                           |   |
| 1          | Client Request ID <sup>3</sup>   | 0x00 – 0xFF   |
| 2          | Status                           | 0x0000 = Success <sup>1</sup> ,<br>0x0001 = Service Not Available <sup>4</sup> ,<br>0x0002 = Invalid message format,<br>0x0003 = Message too long,<br>0x0004 = Invalid Tracker ID,<br>0x0006 = Database Access Error,<br>0x0007 = Service Temporarily Not Available,<br>0x0009 = Low Power Mode,<br>0x0010 = Out of Network |
| 1          | Message Sequence ID <sup>2</sup> | 0x000000 – 0xFFFFFFFF   |
| 2          | Data checksum                    |   |

<sup>1</sup> Success indicates that the message has been successfully queued so that it may be sent to the specified tracker(s).  
<sup>2</sup> ID associated with the message being sent. When the tracker successfully acknowledges and/or responds to this message, the DMCS will receive a "Message Response and State" or a "Message Response and Reduced State" packet within a "Real-time Tracking Data Message" that contains the same Message Sequence ID.  
<sup>3</sup> The ID associated with the request sent by the DMCS.  
<sup>4</sup> If user data was sent to a list of trackers, all trackers in the list must have message service available or this error code will be returned.



**Table 131: Send Tracking Request Message (7209)**

| # of bytes | Description                    | Value or Range          |
|------------|--------------------------------|-------------------------|
| 10         | Header                         |                         |
| 4          | Tracker ID                     | 0x00000000 – 0x03FFFFFF |
| 1          | Client Request ID <sup>1</sup> | 0x00 – 0xFF             |
| 1          | Padding                        | 0x00                    |
| 2          | Data Checksum                  |                         |

<sup>1</sup> The Client Request ID is assigned by the DMCS and is returned by the NDC Server in the response message.

**Table 132: Send Tracking Request Response Message (7409)**

| # of bytes | Description                    | Value or Range  |
|------------|--------------------------------|---|
| 10         | Header                         |   |
| 1          | Client Request ID <sup>2</sup> | 0x00 – 0xFF   |
| 2          | Status                         | 0x0000 = Success <sup>1</sup> ,<br>0x0001 = Service Not Available,<br>0x0002 = Invalid Tracker ID,<br>0x0003 = Database Access Error,<br>0x0004 = Service Temporarily Not Available |
| 1          | Padding                        | 0x00  |
| 2          | Data checksum                  |   |

<sup>1</sup> Success indicates that the message has been successfully queued so that it may be sent to the specified tracker.

<sup>2</sup> The ID associated with the request sent by the DMCS.

**Table 133: Tracker Installation Update Message (7210)**

| # of bytes           | Description                              | Value or Range |
|----------------------|--|----------------|
| 10                   | Header                                   |                |
| 4                    | Tracker ID                               |                |
| 8                    | Tracker Installation Record <sup>1</sup> |                |
| Padding <sup>4</sup> |  |                |
| 2                    | Data Checksum                            |                |

<sup>1</sup> See Tracker Installation Record.

**Table 134: Vehicle Profile Update Message (7212)**

| # of bytes           | Description                         | Value or Range |
|----------------------|-------------------------------------|----------------|
| 10                   | Header                              |                |
| 8                    | Vehicle Profile Format <sup>1</sup> |                |
| Padding <sup>4</sup> |                                     |                |
| 2                    | Data Checksum                       |                |

<sup>1</sup> See Vehicle Profile Format.

What is claimed is:

1           1.       A vehicle fleet management information system for fleet asset management  
2           by enabling identification of location and direction of movement, if any, of each vehicle in  
3           said fleet in real-time and to automatically communicate directly therewith for reporting of  
4           vehicle location, direction and status of predetermined events in which the vehicle may  
5           become engaged, said system comprising:

6                     apparatus for broadcasting information to vehicles in the fleet over a  
7                     communications network in which each vehicle is a participant, with precise time  
8                     synchronization of the broadcast information according to timing employed in a navigation  
9                     system for said fleet relative to a stable reference point,

10                    apparatus in each vehicle for detecting predetermined events of interest and  
11                    reporting information concerning vehicle location and said detected events to a fleet  
12                    management office over said communications network, and

13                    said broadcast apparatus including apparatus for assigning each vehicle in the fleet  
14                    a unique time slot to transmit its reporting information without substantially interfering  
15                    with transmissions from other vehicles in their own respective time slots.

1           2.       The fleet management information system of claim 1, wherein said  
2           broadcast apparatus includes means for broadcasting via FM radio subcarrier.

1           3.       The fleet management information system of claim 1, wherein said stable  
2           navigation reference for position determination is a satellite Global Positioning System  
3           (GPS).

1           4.       The fleet management information system of claim 1, wherein at least some  
2           of said owners have low update rate requirements, and including means for polling  
3           vehicles associated with low update rate owner requests for information, without need for  
4           entry of the polled vehicle reporting transmissions into specific predetermined time slots of  
5           the network.

1           **5.**     The fleet management information system of claim 4, wherein said low  
2     update rate requests for owners providing emergency response services include means for  
3     varying their respective vehicle position update rates in times of emergency.

1           **6.**     The fleet management information system of claim 1, including a network  
2     distribution center including means for providing space diversity processing of said  
3     received vehicle data packets for recovery of possibly corrupted data.

1           **7.**     The fleet management information system of claim 1, including means for  
2     dynamically allocating slots to accommodate update rates of information according to  
3     different periodic reporting intervals by different vehicles in the network.

1           **8.**     The fleet management information system of claim 1, including means for  
2     dynamically allocating slots to allow higher priority data packets to be transmitted to or  
3     from vehicles before lower priority packets that were queued first.

1           **9.**     The fleet management information system of claim 8, including means for  
2     increasing the priority of delayed lower priority packets according to a predetermined  
3     maximum time of delay.

1           **10.**    The fleet management information system of claim 1, including means for  
2     providing auxiliary reporting slots for vehicles to accommodate need for prompt reporting  
3     of important information independent of slower periodic reporting intervals.

1           **11.**    The fleet management information system of claim 1, including means for  
2     inferring the identity of a reporting vehicle to accommodate need for prompt reporting of  
3     important information independent of slower periodic reporting intervals.

1           **12.**    The fleet management information system of claim 1, wherein said  
2     communications network is a time division multiple access (TDMA) wireless network.

1           **13.**    The fleet management information system of claim **12**, wherein said  
2 broadcast apparatus includes means for broadcasting via FM radio subcarrier, said stable  
3 navigation reference for position determination is a satellite Global Positioning System  
4 (GPS), and said FM radio subcarrier is used to broadcast synchronization data to all  
5 TDMA network participants independent of separate delivery of time information from  
6 said GPS navigation reference.

1           **14.**    A management information system for a multiplicity of movable,  
2 information communicating assets whether stationary or undergoing movement, to identify  
3 the location of each asset in real-time and to communicate therewith, said system  
4 comprising:  
5           apparatus for transmitting information to each of said assets via a communications  
6 network in which each of said assets is a participant,  
7           apparatus for receiving information transmitted by each of said assets via said  
8 communications network,  
9           apparatus for detecting the location of each asset relative to an arbitrary stable  
10 reference point in a navigation system,  
11           apparatus for precise time synchronization of information transmitted to each of  
12 said assets with timing information derived from said navigation system, and  
13           apparatus for assigning each of said assets a unique time slot in which to transmit  
14 information to said receiving apparatus over said communications network without  
15 substantially interfering with information transmissions by others of said assets in their  
16 respective time slots.

1           **15.**    A time division multiple access (TDMA) wireless network for real time  
2 reporting of fleet vehicle locations and other information in data packets in respective  
3 assigned time slots to a central data processing location on a UHF band, with a minimum  
4 of gaps between reporting transmissions, said network comprising  
5           means for precise time synchronization of all elements of said TDMA wireless  
6 network, including wireless phase lock loop (PLL) timing control loop means for

7 distributing a single, remote global positioning satellite GPS based time reference  
8 throughout said network.

1           **16.**    The TDMA wireless network of claim **15**, including FM subcarrier  
2 broadcast means having timing data referenced to a GPS based time source for broadcast  
3 to the fleet vehicles.

1           **17.**    The TDMA wireless network of claim **16**, including means for providing  
2 navigation data for the fleet vehicles by other than GPS.

1           **18.**    The TDMA wireless network of claim **16**, including means on each of said  
2 fleet vehicles for receiving data requests and messages from said central station and other  
3 information to synchronize said network elements without a GPS receiver.

1           **19.**    The TDMA wireless network of claim **16**, wherein said PLL timing control  
2 loop means operates as an algorithm for synchronization of the different elements of the  
3 network to a synchronization pattern, using said algorithm to eliminate variability in  
4 synchronization.

1           **20.**    The TDMA wireless network of claim **19**, including means for processing  
2 difference in time from said GPS time reference and received synchronization data on said  
3 FM subcarrier using said PLL algorithm to generate a timing correction.

1           **21.**    A fleet management system for tracking the locations and paths of vehicles  
2 at rest and in transit for management of dispatch and operation of said vehicles,  
3 comprising:  
4           a radio frequency network,  
5           a plurality of geographically disparate network hubs for communication with fleet  
6 management offices and said vehicles over said network,  
7           a tracking computer on each of said vehicles for developing and transmitting

8 navigation and status messages to at least one of said network hubs for communication to  
9 a fleet management office responsible for the respective transmitting vehicle,  
10 apparatus for establishing a protocol for entry by said tracking computers into the  
11 network in assigned time slots for periodic transmission of messages by the respective  
12 tracking computers, and  
13 apparatus for providing space diversity of the messages received by said network  
14 hubs from said tracking computers to avoid corruption of messages received from a single  
15 tracking computer at more than one of said network hubs.

1           **22.** The fleet management system of claim **21**, wherein said network is a time  
2 division multiple access (TDMA) network.

1           **23.** The fleet management system of claim **21**, wherein said protocol  
2 establishing apparatus provides management of different periodic transmission intervals by  
3 different vehicles in the network by dynamically allocating said slots for various update  
4 rates.

1           **24.** The fleet management system of claim **21**, wherein said protocol  
2 establishing apparatus provides auxiliary reporting slots to allow prompt reporting of  
3 important data by the respective tracking computers independent of slower said periodic  
4 transmission intervals.

1           **25.** The fleet management system of claim **21**, including apparatus for  
2 supporting both guaranteed and non-guaranteed delivery of message data.

1           **26.** The fleet management system of claim **21**, wherein said network includes a  
2 dual band full-duplex interface with TDMA on one-half of said interface and broadcast on  
3 the other half of said interface.

1           **27.** The fleet management system of claim **21**, wherein said assigned slots are  
2 unique to respective ones of said tracking computers, whereby to minimize bandwidth

3 usage in said network by enabling identity of the vehicle whose tracking computer is  
4 transmitting according to the time slot in which the transmission is received.

1           **28.** A fleet management system for tracking the locations and paths of vehicles  
2 at rest and in transit for management of dispatch and operation of said vehicles,  
3 comprising:

4           a wireless network,  
5           apparatus for modulating broadcasts transmitted on said network with message  
6 data including a synchronization pattern,  
7           a plurality of geographically disparate network hubs for communication with fleet  
8 management offices and said vehicles over said network,  
9           a tracking computer on each of said vehicles for developing and transmitting  
10 navigation and status messages to at least one of said network hubs for communication to  
11 a fleet management office responsible for the respective transmitting vehicle, and  
12           apparatus for synchronizing the timing of said tracking computers with each other  
13 and with said network hubs by aligning respective internal clocks thereof to said  
14 synchronization pattern pulses in received broadcasts of data on said network,  
15           said synchronizing apparatus including a timing control for correcting drifts in the  
16 timing to maintain synchronization between said tracking computers and said network  
17 hubs.

1           **29.** The fleet management system of claim **28**, wherein said timing control  
2 comprises a remote phase locked loop (PLL) that includes said apparatus for modulating  
3 broadcasts and a network control center that receives broadcasts of data on said network  
4 and computes and transmits a time correction to said apparatus for modulating broadcasts,  
5 to maintain said synchronization.

1           **30.** The fleet management system of claim **29**, wherein said network control  
2 center includes a receiver for receiving Global Positioning System (GPS) satellite signals  
3 including a GPS time reference and means for obtaining the difference between the  
4 average time of said received synchronization pattern and the time of said received GPS

5 time reference from which to compute said time correction.

1           **31.** The fleet management system of claim **30**, wherein said network includes a  
2 time division multiple access (TDMA) network, and said timing control PLL includes  
3 means for maintaining said synchronization in said TDMA network to about three  
4 microsecond accuracy.

1           **32.** The fleet management system of claim **28**, wherein said timing control  
2 comprises an RF link phase lock loop to maintain clock synchronization to a reference.

1           **33.** The fleet management system of claim **30**, wherein said network includes a  
2 dual band full-duplex interface with TDMA on one-half of said interface and broadcast on  
3 the other half of said interface.

1           **34.** The fleet management system of claim **33**, including a remote reference  
2 controlled through a wireless link for synchronizing the TDMA portion of said network to  
3 GPS time.

1           **35.** The fleet management system of claim **33**, wherein each of said tracking  
2 computers and said network hubs includes a central processing unit comprising a  
3 microprocessor with a time processing unit for performing precise clock synchronization  
4 within 10 microseconds for the TDMA portion of said network.

1           **36.** The fleet management system of claim **28**, including means for maintaining  
2 synchronization between said tracking computers and said network hubs and to a  
3 synchronization pattern, using the same algorithm to eliminate variability in  
4 synchronization.

1           **37.** An article management system for tracking the locations of articles at rest  
2 and in transit for maintaining a desired flow of said articles, said system providing  
3 bandwidth efficient wireless transceiver operation and comprising:



4 a plurality of data transmitters and a plurality of data receivers for communication  
5 via a wireless network with respect to location of said articles,

6 means in each of said transmitters for filtering baseband data to reduce the  
7 occupied bandwidth of the channel on which data is transmitted, including removal of  
8 synchronization data to minimize overhead of non-information bearing data,

9 said baseband filter being implemented by a digital microcontroller that replaces an  
10 original square wave data stream of said baseband data with deterministic transitions that  
11 reduce harmonic content and maintain bit widths, regardless of data input frequency.

1 **38.** The article management system of claim **37**, including  
2 means in each of said receivers for applying processor intensive clock and data  
3 recovery algorithms to facilitate said removal of synchronization data by said filter means  
4 at said transmitters.

1 **39.** The article management system of claim **38**, wherein said transmitters and  
2 receivers further employ forward error correction coding and space diversity processing to  
3 increase the reliability of received data, whereby to further optimize bandwidth reduction  
4 by eliminating bandwidth needed for retransmission of corrupted data.

1 **40.** The article management system of claim **37**, wherein said digital  
2 microcontroller comprises a digital filter that uses sine wave segments for transitions.

1 **41.** The article management system of claim **37**, wherein each of said receivers  
2 includes means to facilitate recovery of transmitted data without transmitted  
3 synchronization information by locating the start of each transmitted data message within a  
4 predetermined scant time window without aid from bit synchronization patterns.

1 **42.** The article management system of claim **41**, wherein said data recovery  
2 means performs said start message start location within said predetermined scant time  
3 window by an iterative search that sequentially clocks in the data at greater and greater  
4 delays from the nominal message start time until a valid data packet is located.

1           **43.**    The article management system of claim **37**, wherein each of said  
2 transmitters further includes means for performing a bit interleaving pattern on the data to  
3 be transmitted to provide a randomization of the data bits to ensure that single bit shifts in  
4 received data cause errors in all code words.

1           **44.**    The article management system of claim **43**, wherein each of said receivers  
2 further includes means for de-interleaving received data according to said bit interleaving  
3 pattern introduced by said interleaving means at each of said transmitters.

1           **45.**    The article management system of claim **37**, wherein said wireless network  
2 includes a time division multiple access (TDMA) network, and each of said receivers  
3 includes means for batch processing of received messages from said transmitters to  
4 recover clock and data on a packet by packet basis in said TDMA network.

1           **46.**    The article management system of claim **45**, wherein said means for batch  
2 processing of received messages includes means for delay decoding sampled bits of the  
3 received data, with only predetermined allowable bit patterns present in the delay code,  
4 whereby if a bit error causes an invalid pattern, the pattern is decoded to one of the  
5 possible bits represented by the pattern, and if subsequent error detection processing on  
6 the decoded data indicates an error, then, if only one ambiguous data pattern was  
7 encountered in that particular code word during the delay decoding process, the other bit  
8 value is used and the error detection is repeated, and, if successful, the second bit value is  
9 retained.

1           **47.**    The article management system of claim **46**, wherein said delay decoding  
2 means retains the original value of said one of the possible bits if more than one bit is  
3 ambiguous or the second bit also fails to result in valid data, and allows processing to  
4 move forward on the premise that the bit error may be correctable at a later stage in the  
5 data processing chain.

1           **48.**    The article management system of claim **47**, wherein each of said receivers  
2 further includes means for de-interleaving received data according to a bit interleaving  
3 pattern introduced at each of said transmitters in which the transmitted data is jumbled  
4 sufficiently that single bit shifts cause all code words to be in error.

1           **49.**    The article management system of claim **37**, including further processing of  
2 received data by diversity processing using a combination of error detection and voting.

1           **50.**    A fleet management system for tracking the locations of vehicles in the fleet  
2 and determining the status of events related to the usage or function of the vehicles,  
3 comprising:

4                navigation apparatus on each vehicle for detecting the location of the vehicle  
5 relative to a predetermined reference point,  
6                a tracking computer on each of said vehicles for receiving inputs indicative of the  
7 location of the vehicle and transmitting navigation and status messages to a fleet  
8 management office responsible for the respective transmitting vehicle,  
9                at least one non-human sensor on each vehicle for detecting one of said events and  
10 supplying an input indicative of the detected event to said tracking computer, and  
11                said tracking computer including apparatus for automatic reporting of the detected  
12 events to said fleet management office.

1           **51.**    The fleet management system of claim **50**, wherein said fleet vehicles and  
2 said fleet management office are connected for communication by a wireless network.

1           **52.**    The fleet management system of claim **51**, wherein each vehicle has a  
2 plurality of sensors for detecting or measuring various ones of said events and supplying  
3 inputs indicative thereof to said tracking computer for prompt reporting of event data as it  
4 happens over said wireless network.

1           **53.**    The fleet management system of claim **52**, wherein at least some of said  
2 plurality of sensors are selected from a group consisting of detectors of vehicle ignition,

3 vehicle run time, headlights on, transmission in forward and reverse directions, wheel  
4 speed, passenger or driver door open, four wheel drive engagement, vehicle emergency  
5 lights or sirens operating, fuel level, coolant temperature, oil pressure, battery voltage,  
6 engine warning indications, theft or tamper alarms, cargo door open, cargo temperature,  
7 vehicle weight, power takeoff engagement for equipment including pumps, winches,  
8 cranes, or augers, engine data bus parameters and tolerance checking, dump box up or  
9 hatch open, ready mix drum rotation speed and direction, ready mix wash water usage,  
10 ready mix fill water volume, distance traveled between predetermined zones, engine on  
11 and off, excessive vehicle speed, driving at improper times, unauthorized stops of vehicle,  
12 and arrival/departure times at specified locations.

1           **54.** The fleet management system of claim **51**, including apparatus at said fleet  
2 management office for correlating a detected event to a vehicle location or vehicle speed.

1           **55.** The fleet management system of claim **54**, wherein said vehicle location  
2 correlation apparatus includes means for comparing the vehicle location detected by said  
3 navigation apparatus to predetermined geographically mapped zones.

1           **56.** The fleet management system of claim **51**, including apparatus at said fleet  
2 management office for defining map regions constituting zones in areas expected to be  
3 traversed by said fleet vehicles, and wherein said apparatus for automatic reporting  
4 includes using said navigation apparatus of the associated fleet vehicle to report one or  
5 more of distance traveled by the vehicle between zones, vehicle engine on and off, vehicle  
6 being driven at excessive speed, vehicle being driven at improper times, vehicle making  
7 unauthorized stops, and times of arrival and departure at preselected locations.

1           **57.** The fleet management system of claim **51**, wherein said fleet vehicles are  
2 ambulances and said automatic reporting reports trips, call times, pick up locations, and  
3 hospitals to which deliveries are made to said fleet management office.

1           **58.** The fleet management system of claim **50**, wherein said apparatus for

2 automatic reporting of the detected events reports exceptions to routine operations of the  
3 vehicle to said fleet management office.

1 **59.** The fleet management system of claim 52, wherein said fleet vehicles are  
2 ready mix concrete or other slurry material mixer trucks, and said plurality of sensors  
3 detect or measure at least some of the events of truck fully loaded at plant site, truck  
4 departure from plant site, truck arrival at job site, truck commencing pour, truck pour  
5 ended, truck undergoing wash, truck departure from job site, truck arrival at plant site,  
6 and deviations from a routine sequence of said events; and at least some of said events are  
7 detected based on truck speed or time interval over which an event takes place.

1 **60.** The fleet management system of claim 59, wherein at least some of said  
2 mixer trucks of said fleet vehicles are equipped with hall effect sensors that measure both  
3 speed and direction of rotation of the mixer drum of the truck.

1 **61.** The fleet management system of claim 50, wherein said fleet vehicles are  
2 bulk powdered material transport trucks in which air is pumped through pipes under the  
3 bulk hopper of the truck for unloading the powdered material therefrom, and each of said  
4 transport trucks includes a tachometer sensor for on/off detection of pumping to indicate  
5 unloading and cessation of unloading of powdered material from the respective said  
6 transport truck to report same to said fleet management office.

1 **62.** The fleet management system of claim 50, wherein said fleet vehicles are  
2 bulk aggregate material transport trucks each having a dumper for unloading the aggregate  
3 material therefrom, and each of said transport trucks includes a sensor for detection of  
4 dumper operation to indicate unloading and cessation of unloading of aggregate material  
5 from the respective said transport truck to report same to said fleet management office.

1 **63.** A fleet management system for a fleet of vehicles, comprising transceivers  
2 on said vehicles and in geographically disparate hubs for communication between a fleet  
3 management office and said vehicles, a network for said communication, and a central

4        processing unit in each of said transceivers comprising a microprocessor with a time  
5        processing unit for performing precise clock synchronization of said transceivers  
6        throughout said network.

1                **64.**    The fleet management system of claim **63**, wherein said network is a  
2        wireless network.

**65.**    The fleet management system of claim **64**, wherein said wireless network is  
a time division multiple access (TDMA) network.

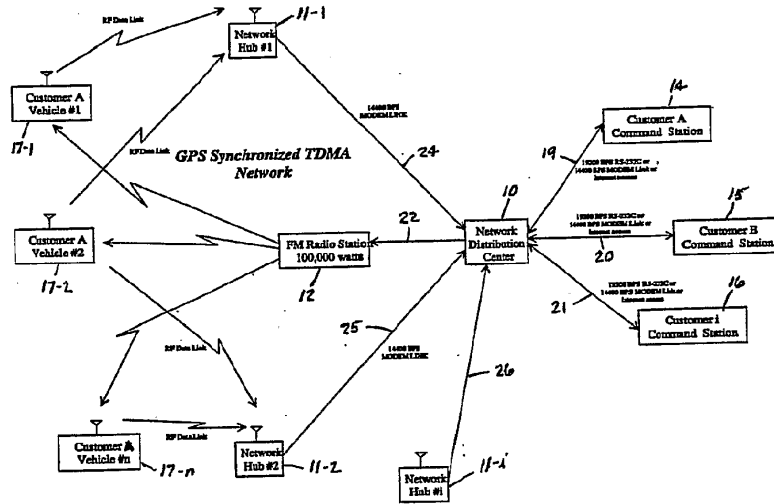


FIG. 1

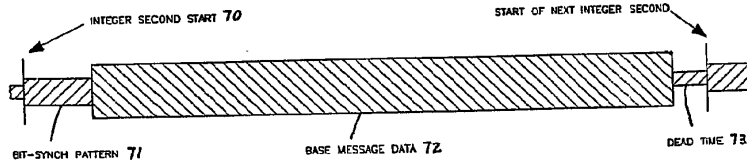


FIG. 7

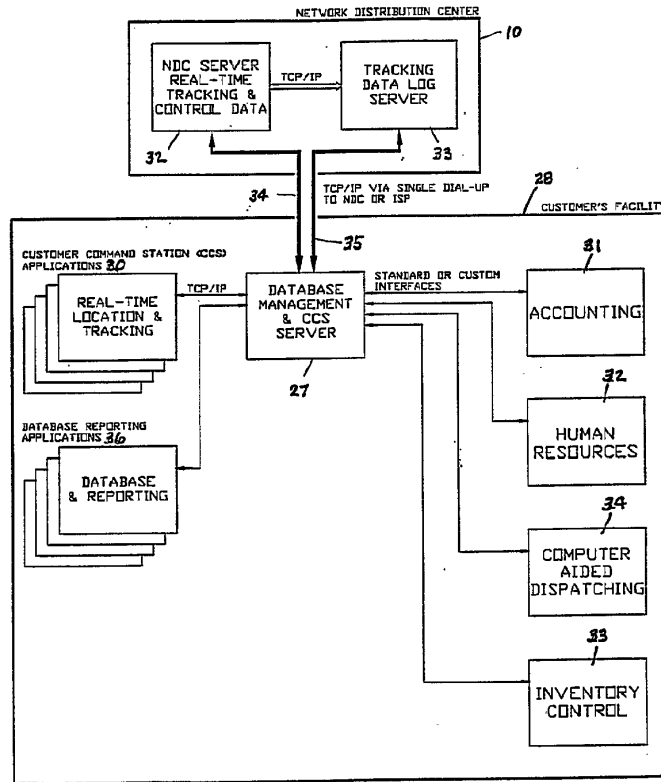
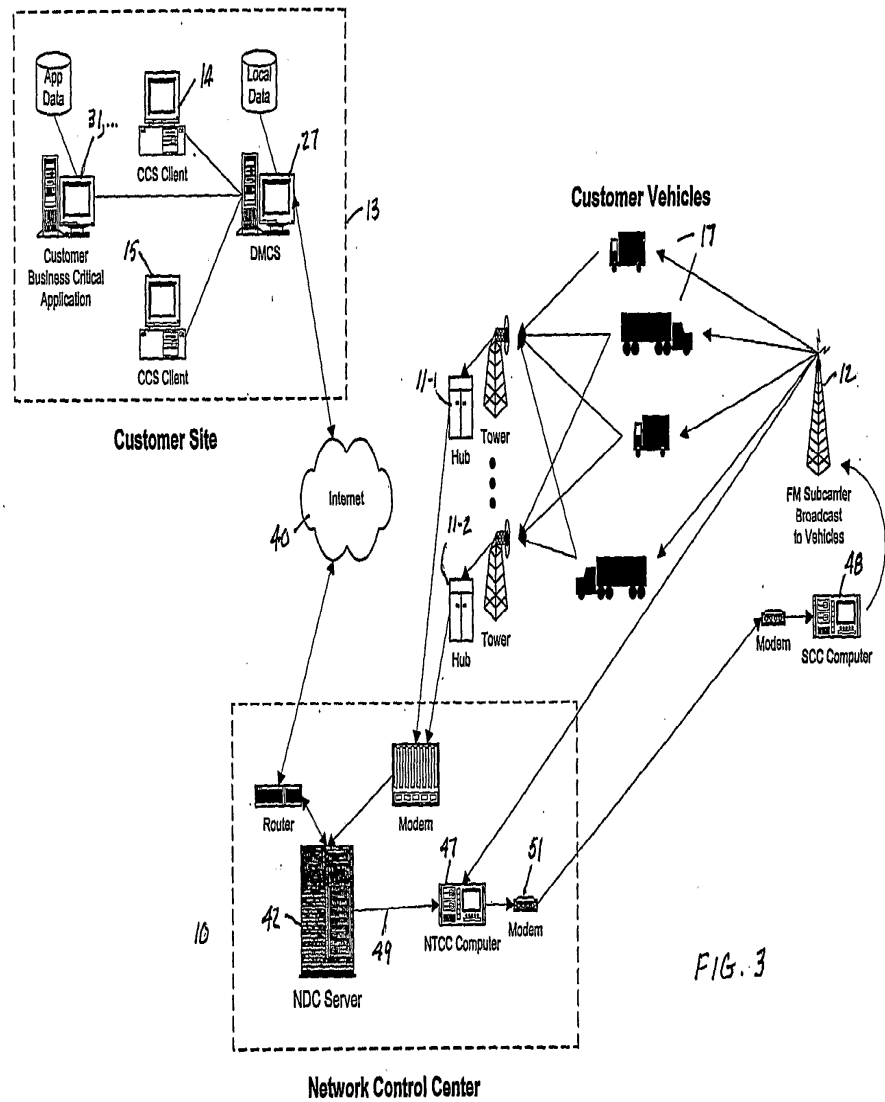


FIG. 2







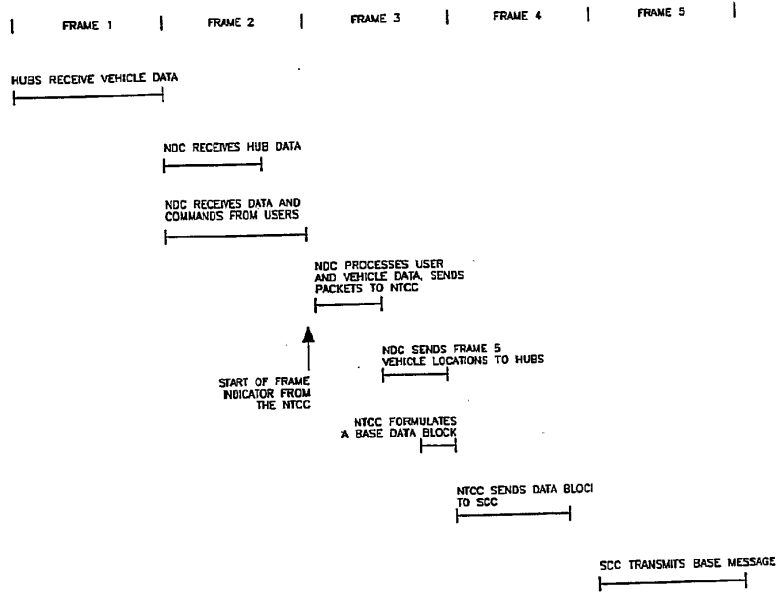


FIG. 5

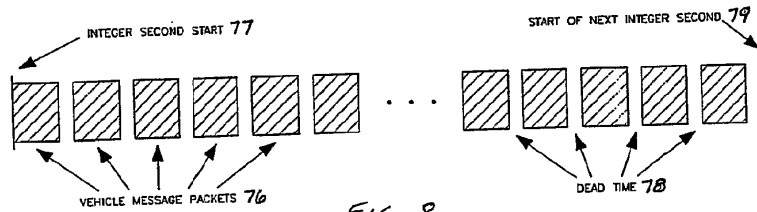


FIG. 8

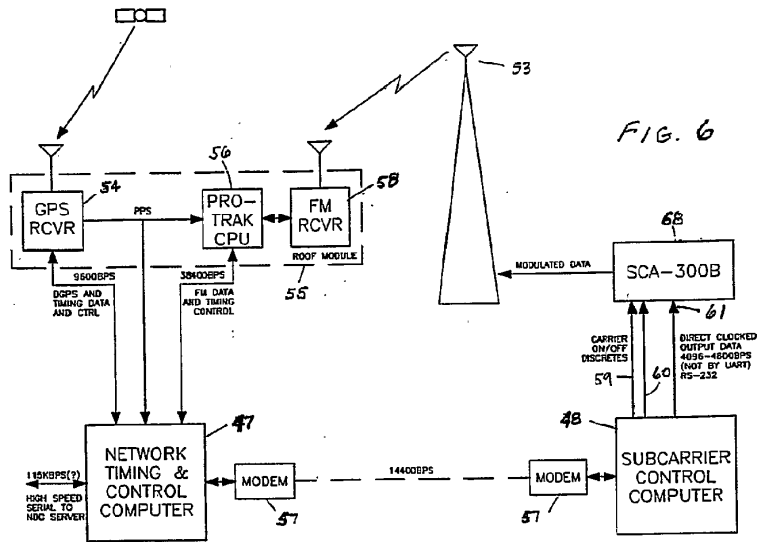


FIG. 6

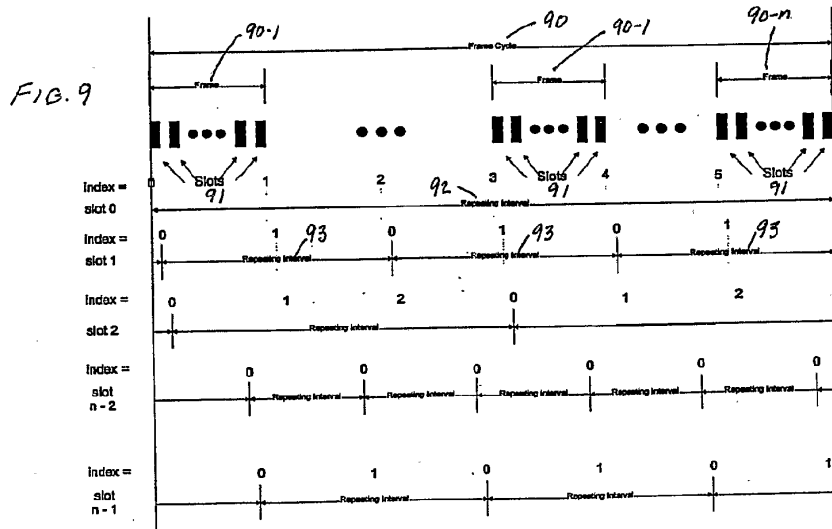


FIG. 9

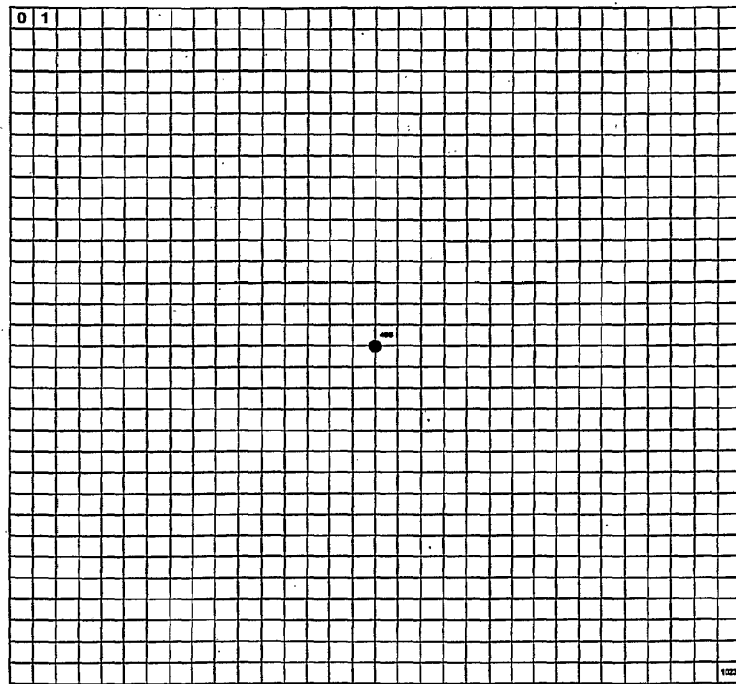
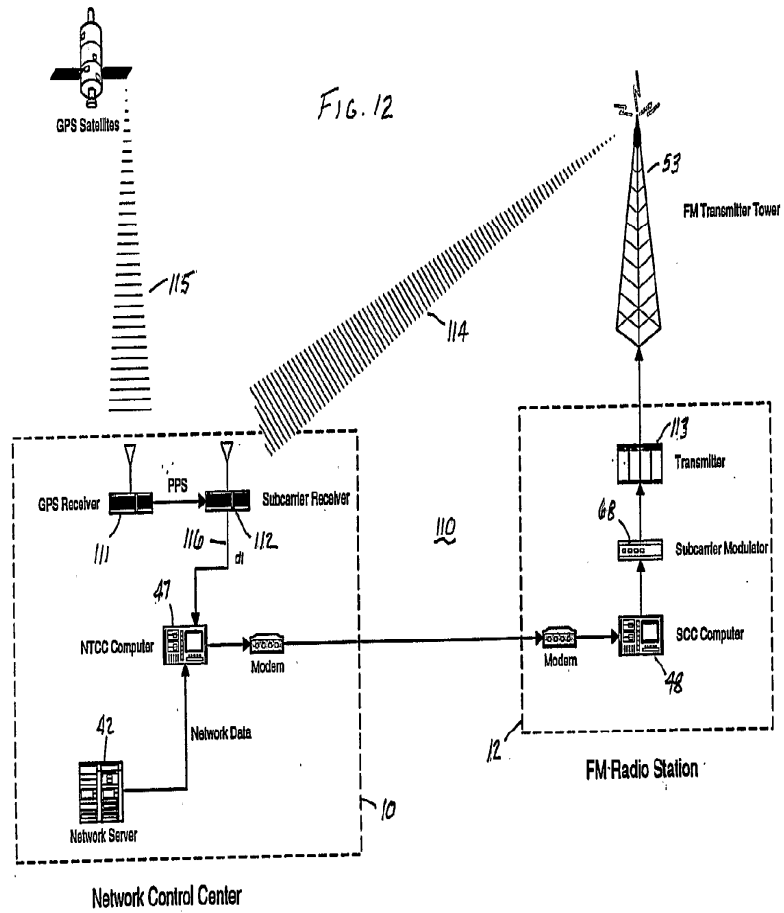


FIG. 11



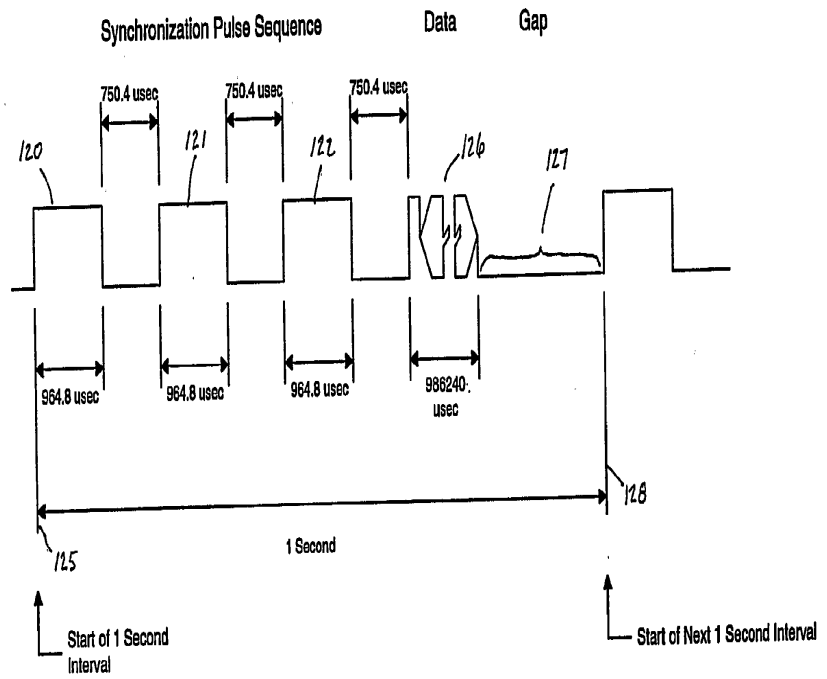


FIG. 13

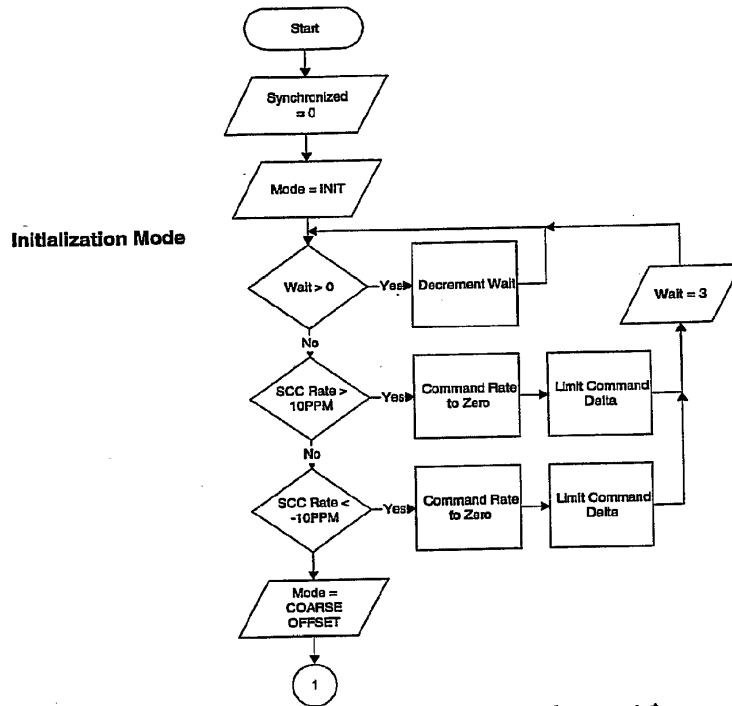
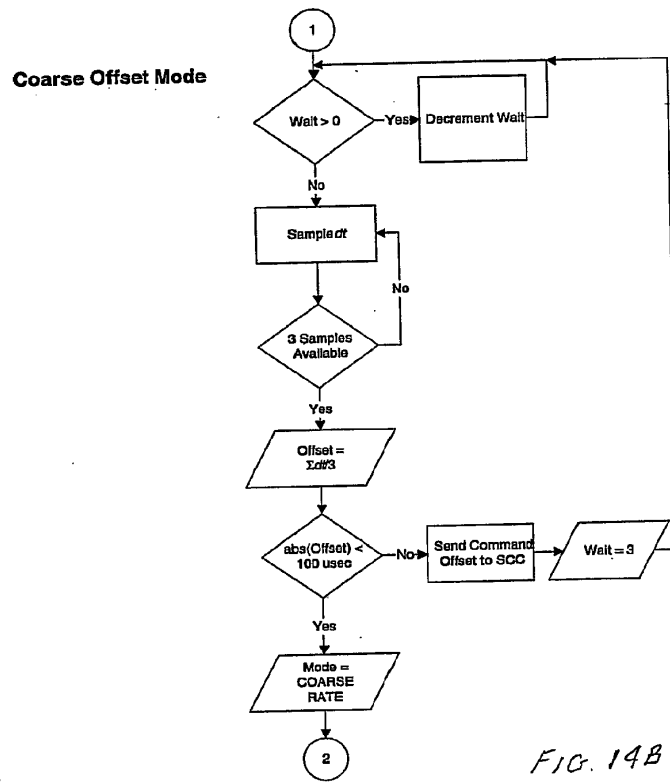
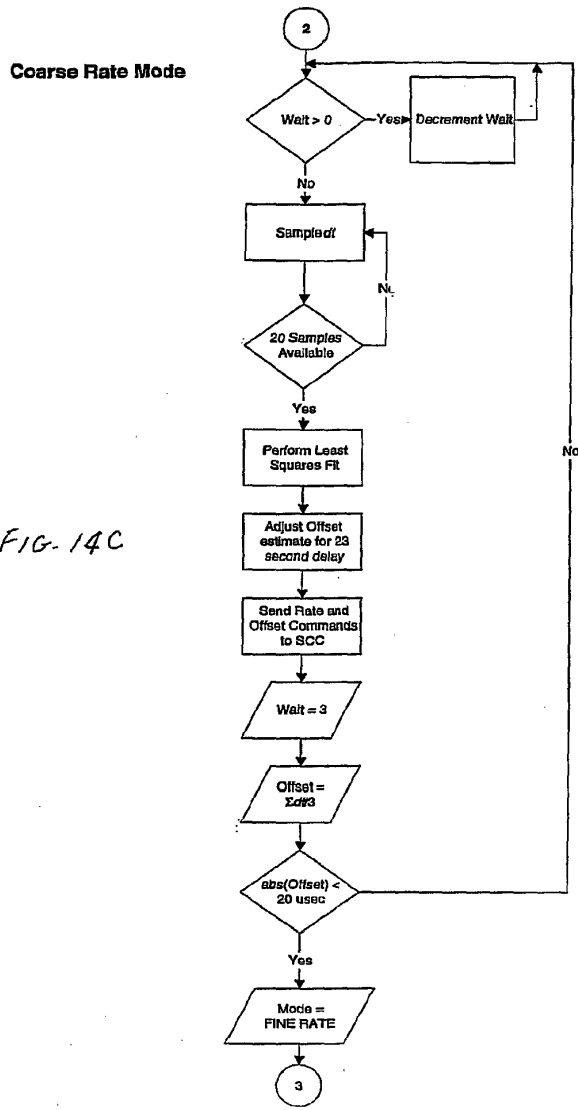


FIG. 14A

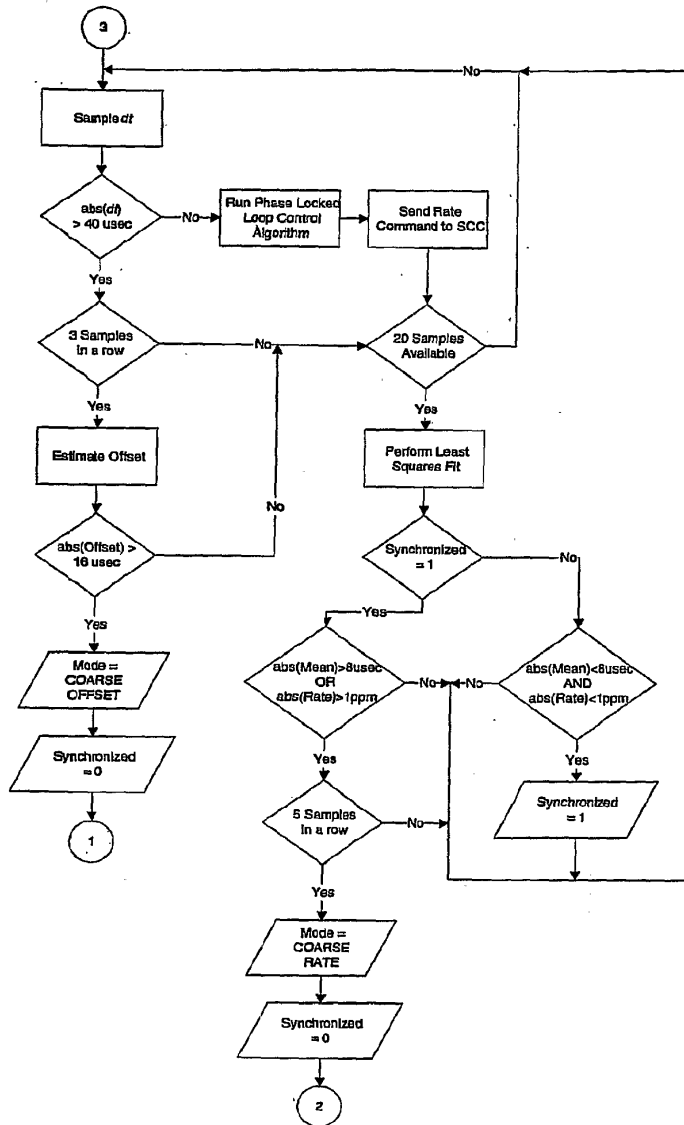






Fine Rate Mode

FIG. 140



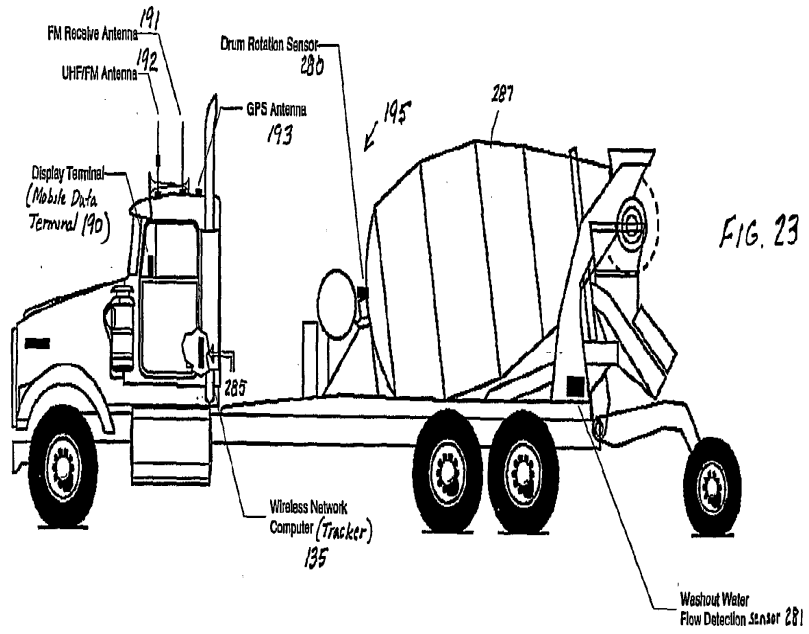


FIG. 23

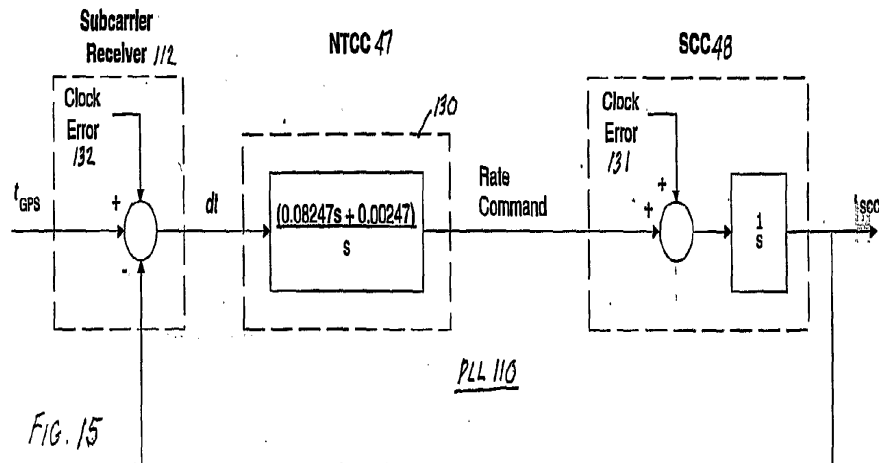
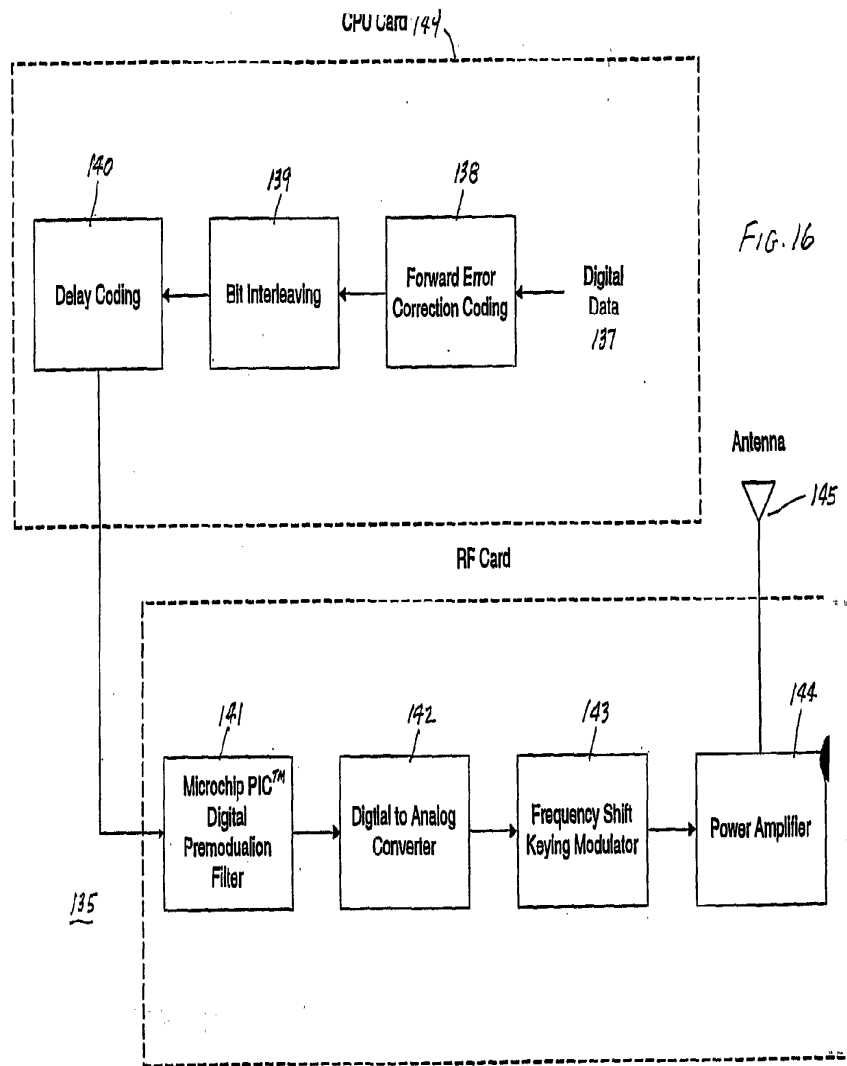


FIG. 15



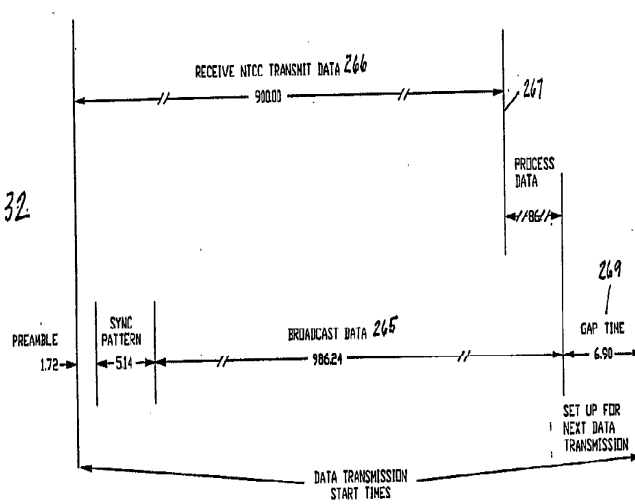
TDMA Transmitt BR Interleaving

| Words | Bits      |          |          |          |          |          |          |          |          |          |           |           |
|-------|-----------|----------|----------|----------|----------|----------|----------|----------|----------|----------|-----------|-----------|
|       | 11        | 10       | 9        | 8        | 7        | 6        | 5        | 4        | 3        | 2        | 1         | 0         |
| 0     | 1/0 000   | 2/0 001  | 3/0 002  | 4/0 003  | 5/0 004  | 6/0 005  | 7/0 006  | 8/0 007  | 9/0 008  | 10/0 009 | 11/0 010  | 0/1 011   |
| 1     | 2/1 012   | 3/1 013  | 4/1 014  | 5/1 015  | 6/1 016  | 7/1 017  | 8/1 018  | 9/1 019  | 10/1 020 | 11/1 021 | 0/2 022   | 1/2 023   |
| 2     | 3/2 024   | 4/2 025  | 5/2 026  | 6/2 027  | 7/2 028  | 8/2 029  | 9/2 030  | 10/2 031 | 11/2 032 | 0/3 033  | 1/3 034   | 2/3 035   |
| 3     | 4/3 036   | 5/3 037  | 6/3 038  | 7/3 039  | 8/3 040  | 9/3 041  | 10/3 042 | 11/3 043 | 0/4 044  | 1/4 045  | 2/4 046   | 3/4 047   |
| 4     | 5/4 048   | 6/4 049  | 7/4 050  | 8/4 051  | 9/4 052  | 10/4 053 | 11/4 054 | 0/5 055  | 1/5 056  | 2/5 057  | 3/5 058   | 4/5 059   |
| 5     | 6/5 060   | 7/5 061  | 8/5 062  | 9/5 063  | 10/5 064 | 11/5 065 | 0/6 066  | 1/6 067  | 2/6 068  | 3/6 069  | 4/6 070   | 5/6 071   |
| 6     | 7/6 072   | 8/6 073  | 9/6 074  | 10/6 075 | 11/6 076 | 0/7 077  | 1/7 078  | 2/7 079  | 3/7 080  | 4/7 081  | 5/7 082   | 6/7 083   |
| 7     | 8/7 084   | 9/7 085  | 10/7 086 | 11/7 087 | 0/8 088  | 1/8 089  | 2/8 090  | 3/8 091  | 4/8 092  | 5/8 093  | 6/8 094   | 7/8 095   |
| 8     | 9/8 096   | 10/8 097 | 11/8 098 | 0/9 099  | 1/9 100  | 2/9 101  | 3/9 102  | 4/9 103  | 5/9 104  | 6/9 105  | 7/9 106   | 8/9 107   |
| 9     | 10/9 108  | 11/9 109 | 0/10 110 | 1/10 111 | 2/10 112 | 3/10 113 | 4/10 114 | 5/10 115 | 6/10 116 | 7/10 117 | 8/10 118  | 9/10 119  |
| 10    | 11/10 120 | 0/11 121 | 1/11 122 | 2/11 123 | 3/11 124 | 4/11 125 | 5/11 126 | 6/11 127 | 7/11 128 | 8/11 129 | 9/11 130  | 10/11 131 |
| 11    | 0/0 132   | 1/1 133  | 2/1 134  | 3/1 135  | 4/1 136  | 5/1 137  | 6/1 138  | 7/1 139  | 8/1 140  | 9/1 141  | 10/11 142 | 11/11 143 |

WB indicates bit, B, of the original code word, W.  
Words are transmitted MSB first; the small number indicates transmit bit order

FIG. 17

FIG. 32



NOTE: TIMES IN MILLISECONDS

17/33

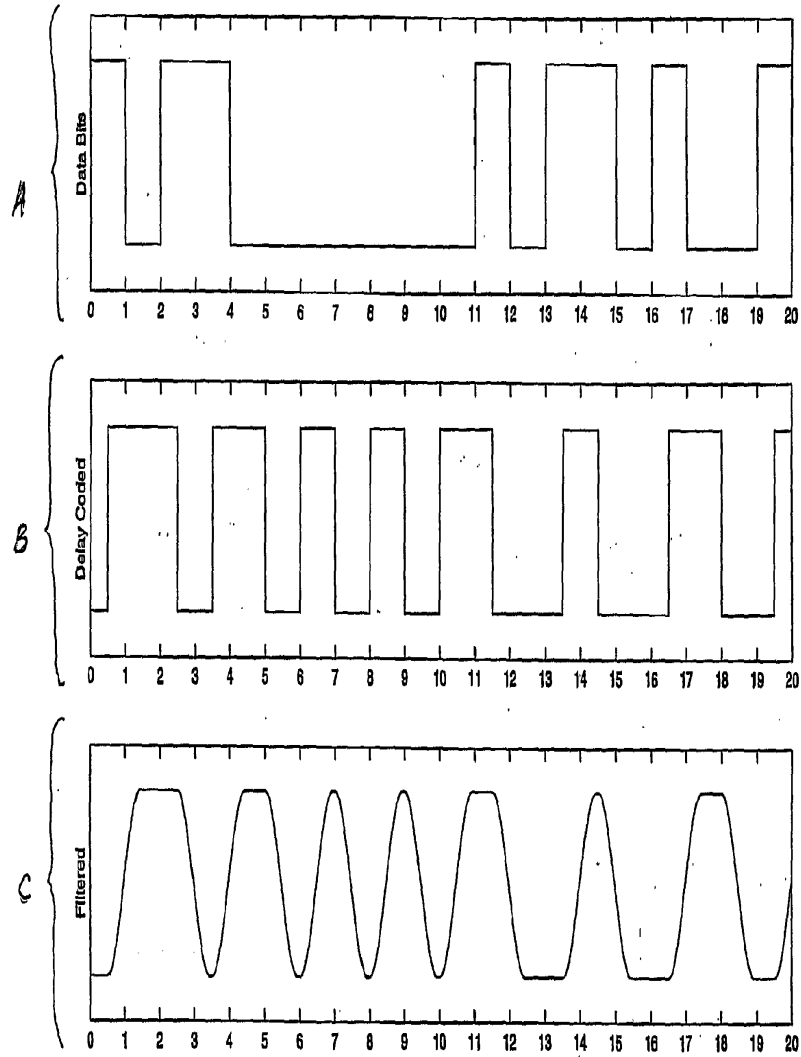


FIG. 18

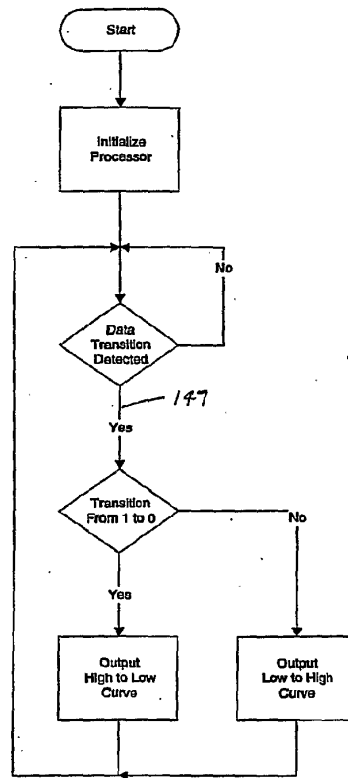


FIG. 19



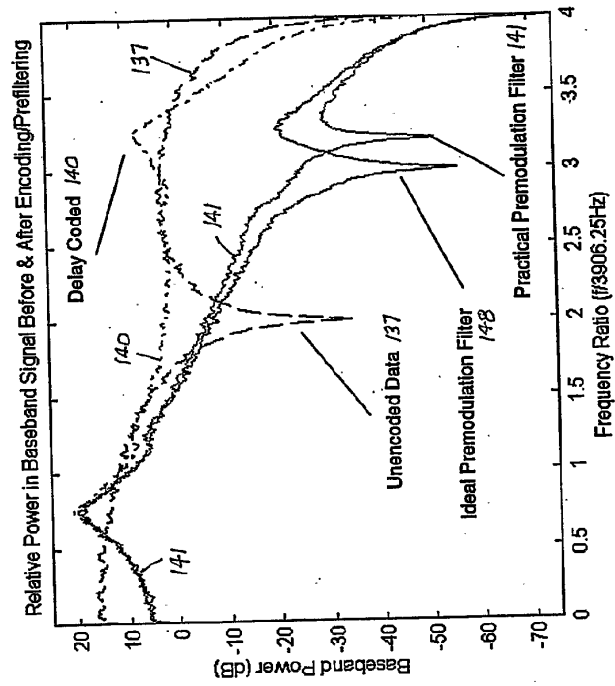


FIG. 20

20/33

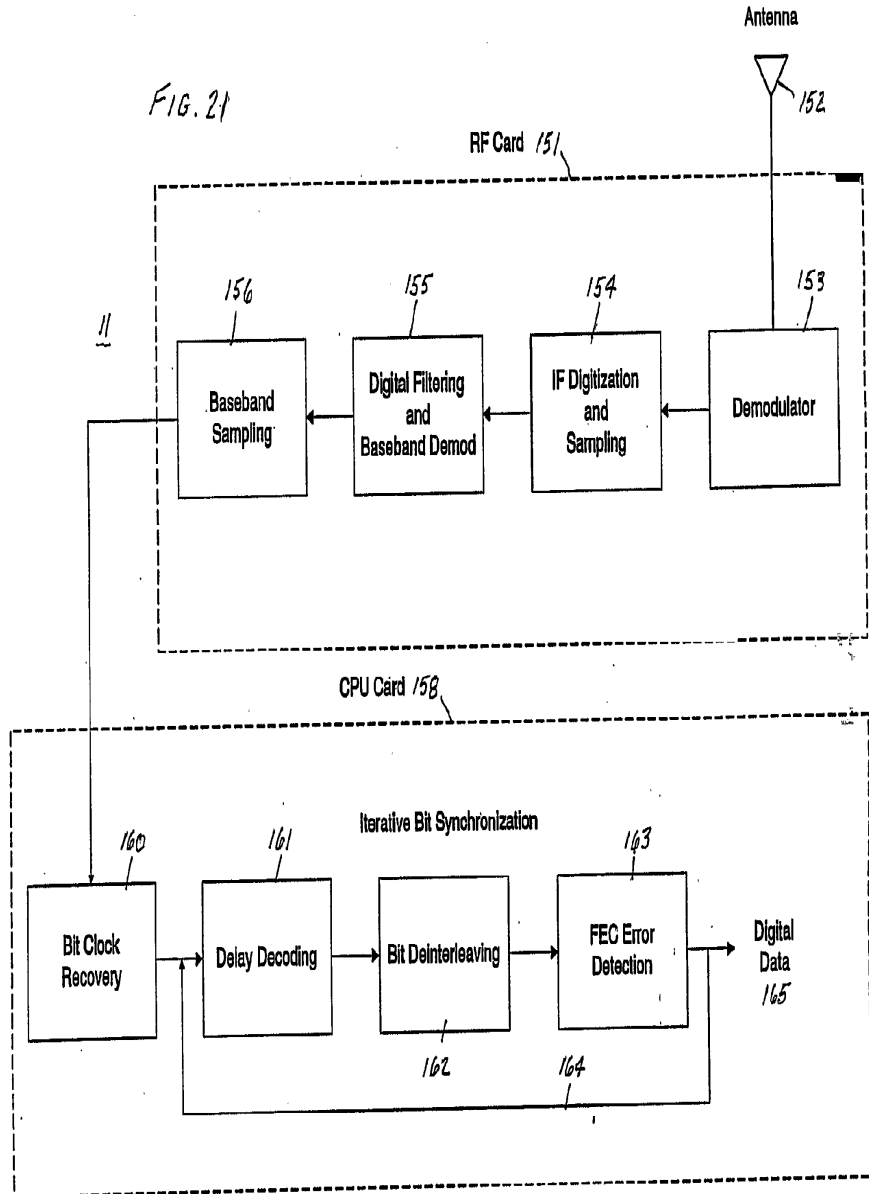
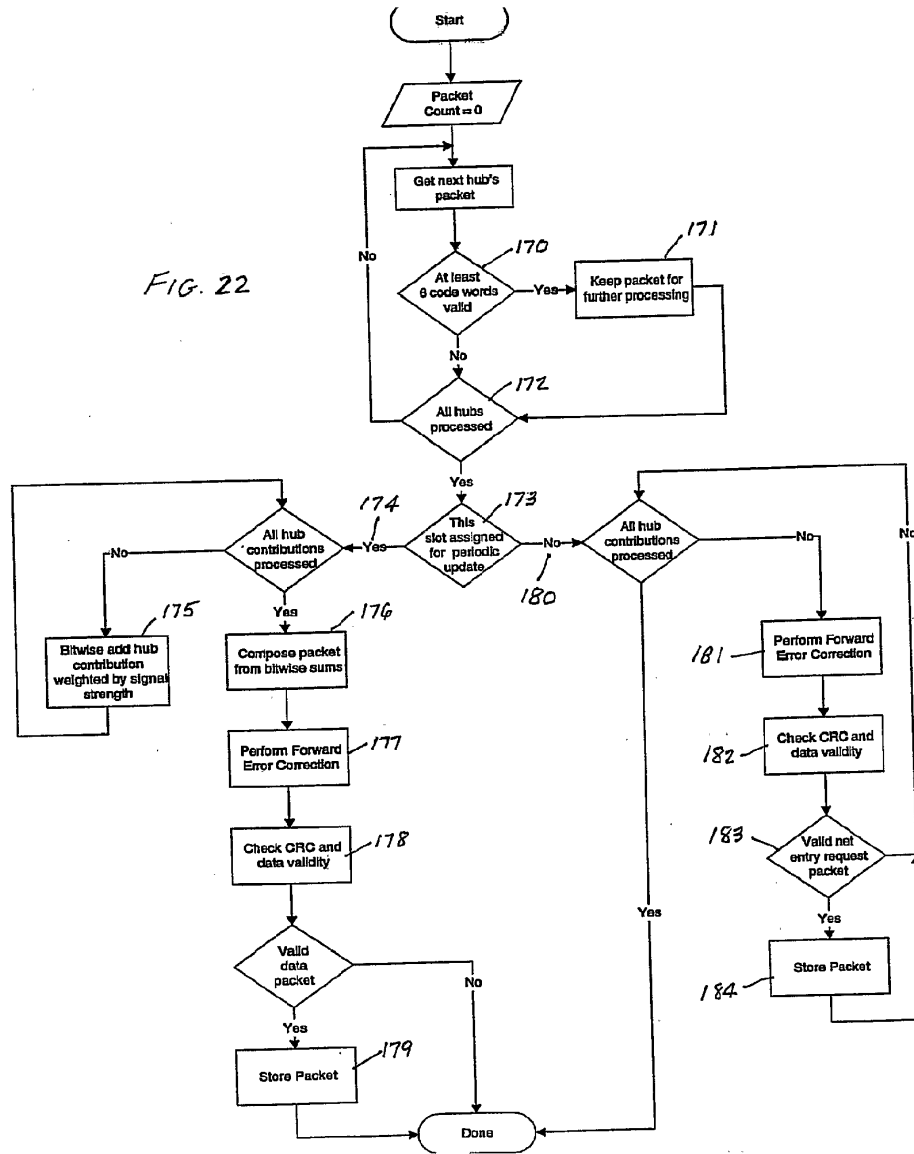


FIG. 22



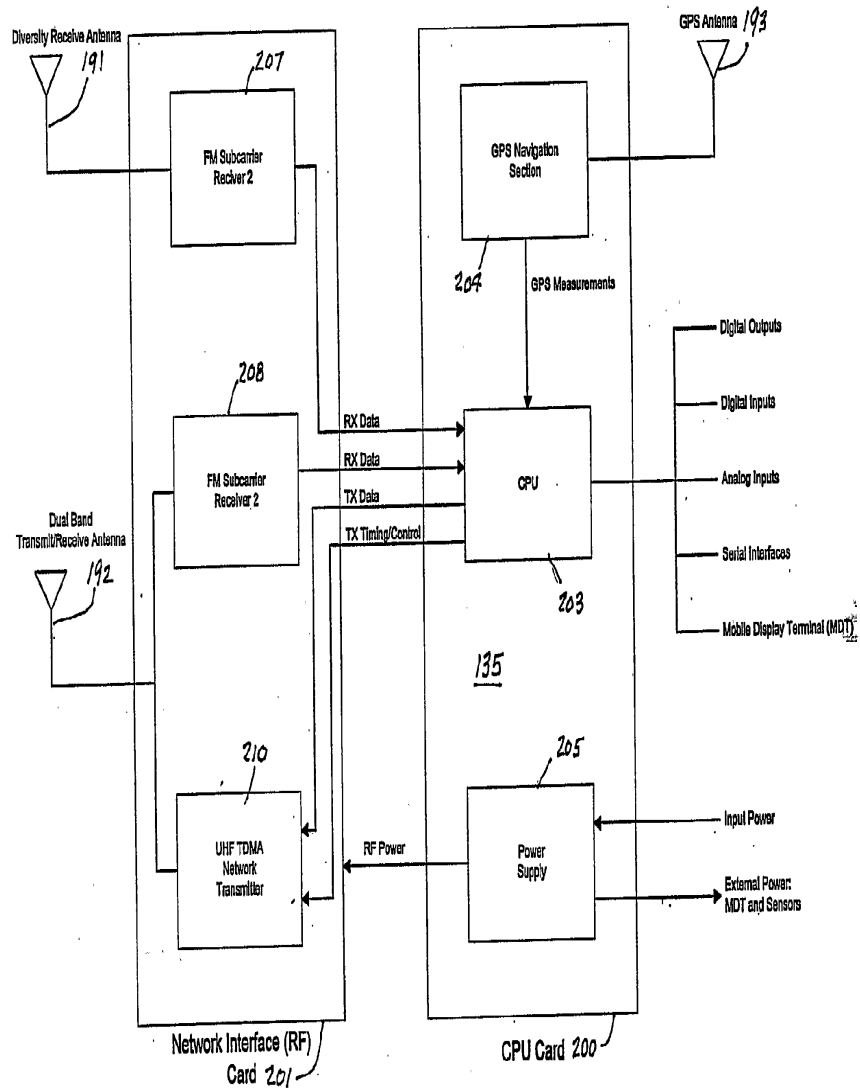
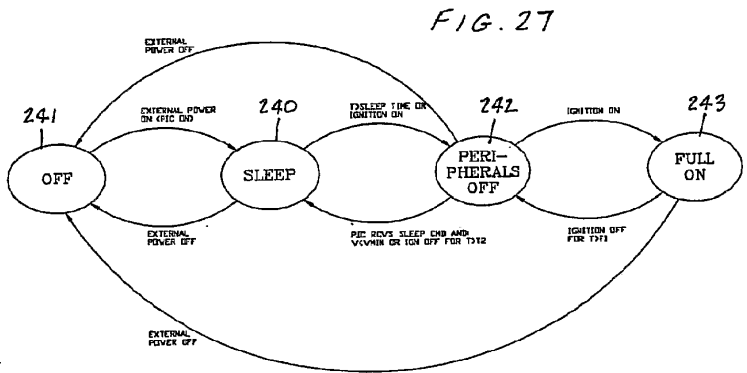
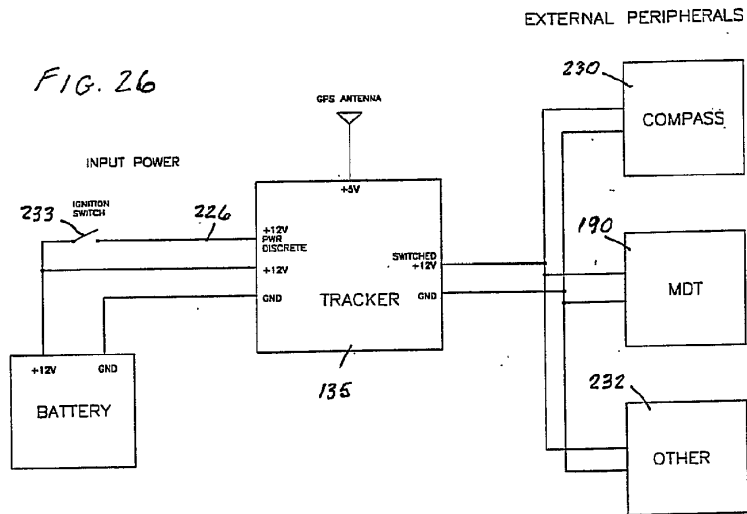


FIG. 7A





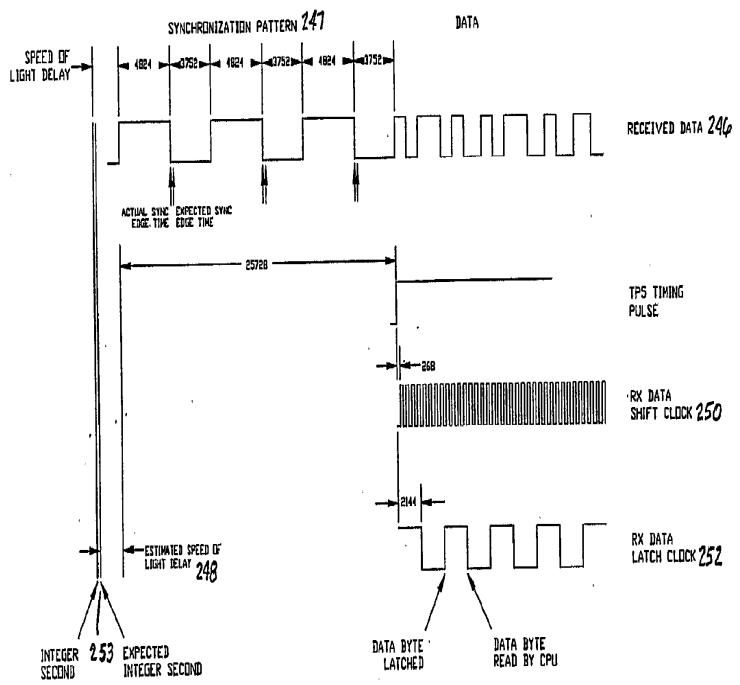


FIG. 28

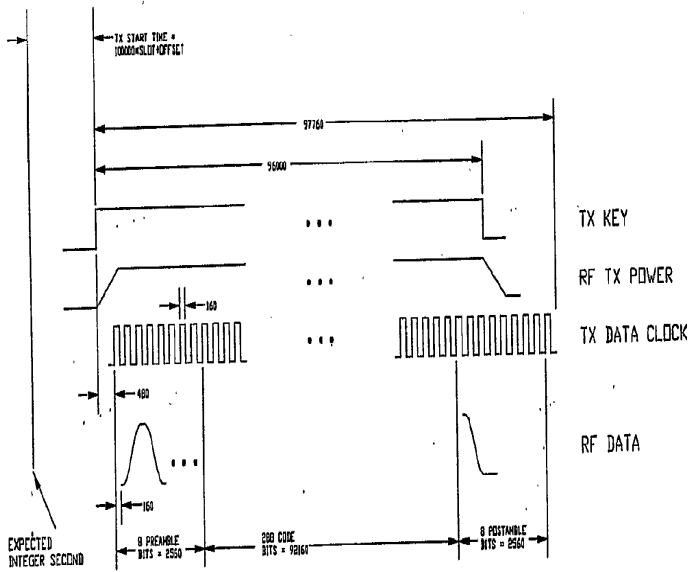
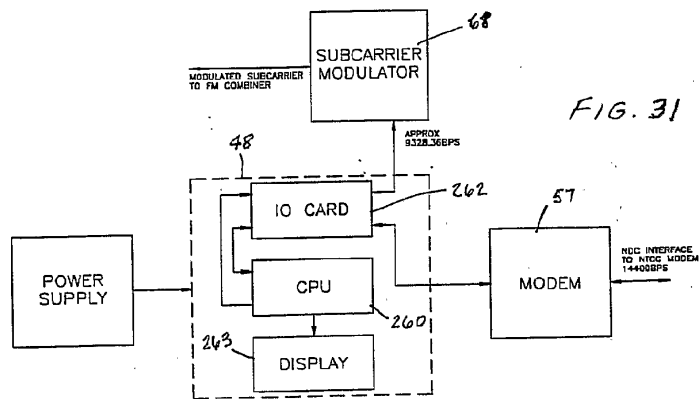
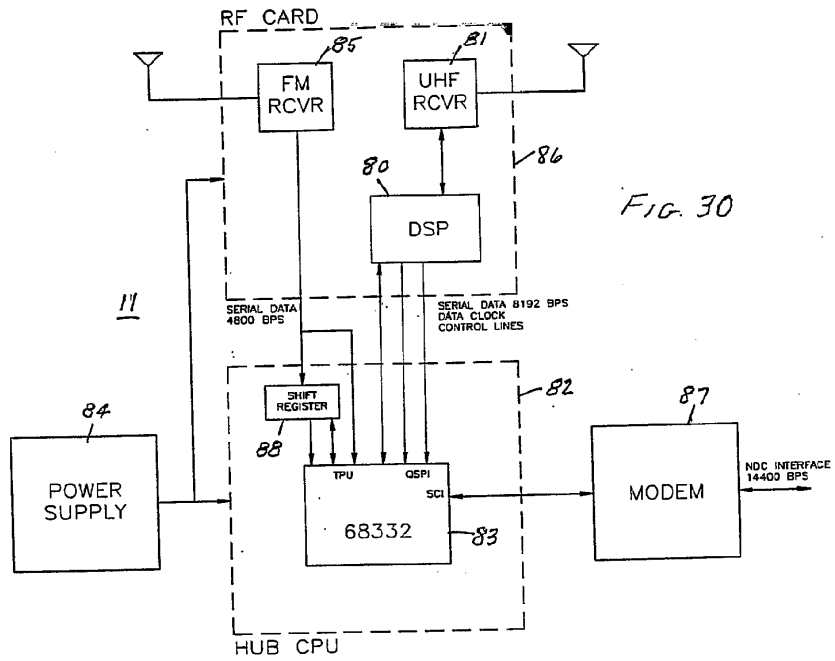


FIG. 29





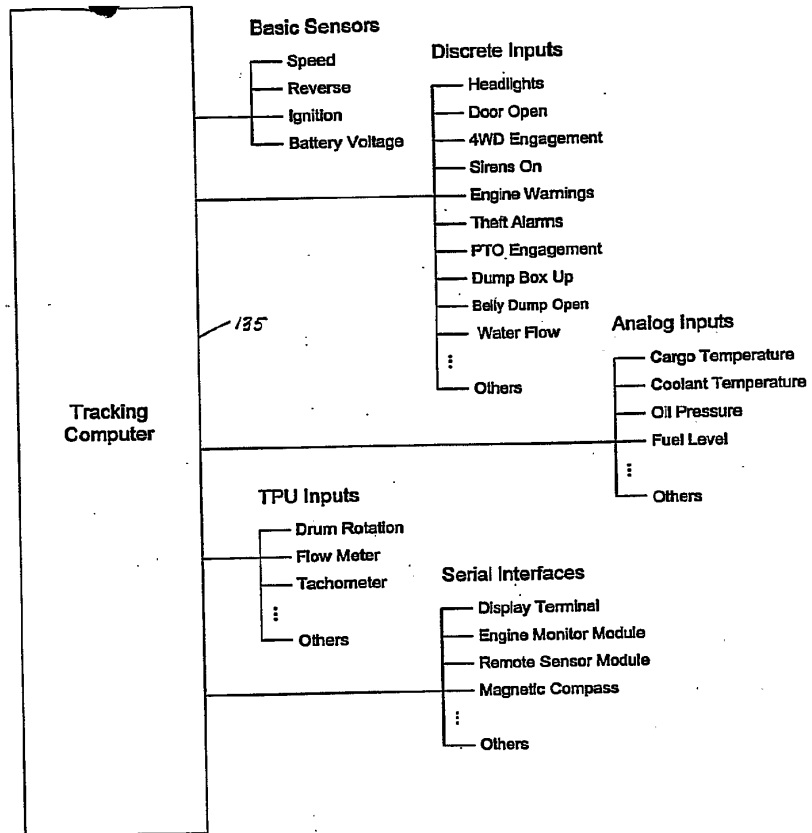


FIG. 33

29/33

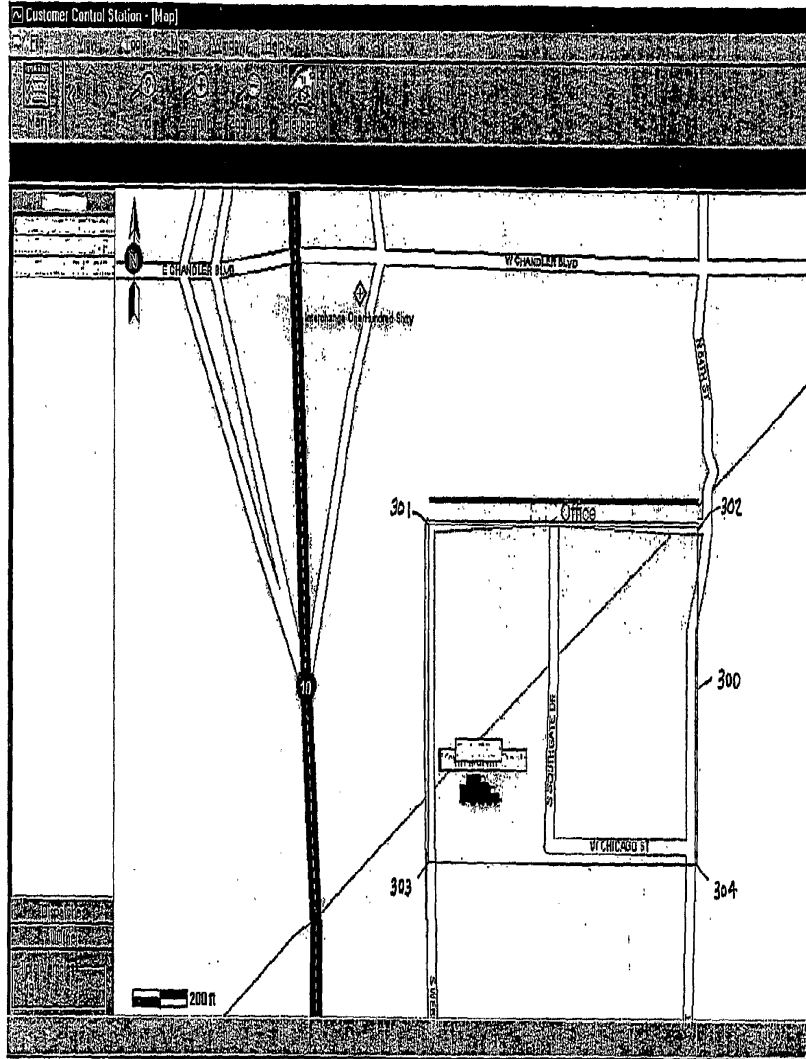


FIG. 34

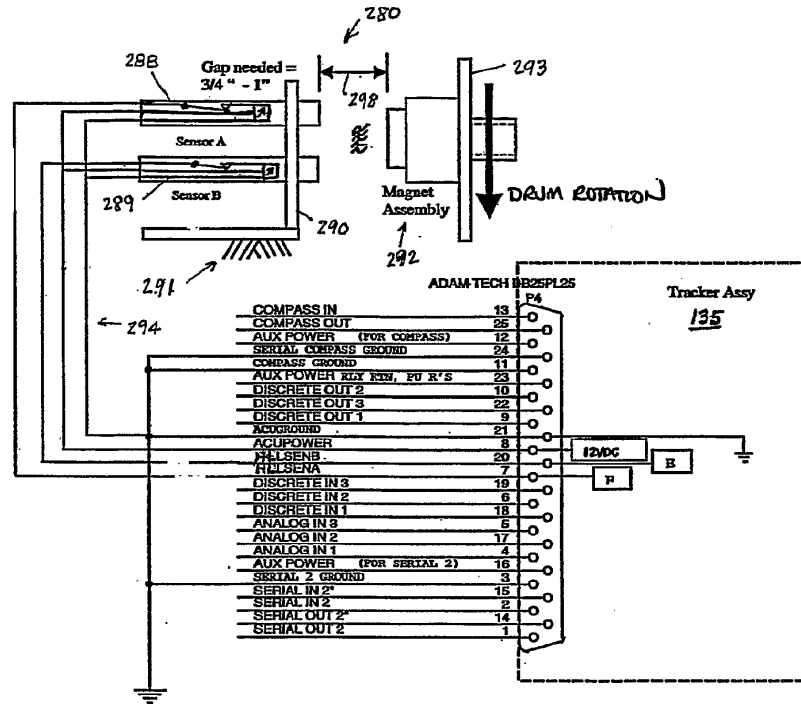


FIG. 35

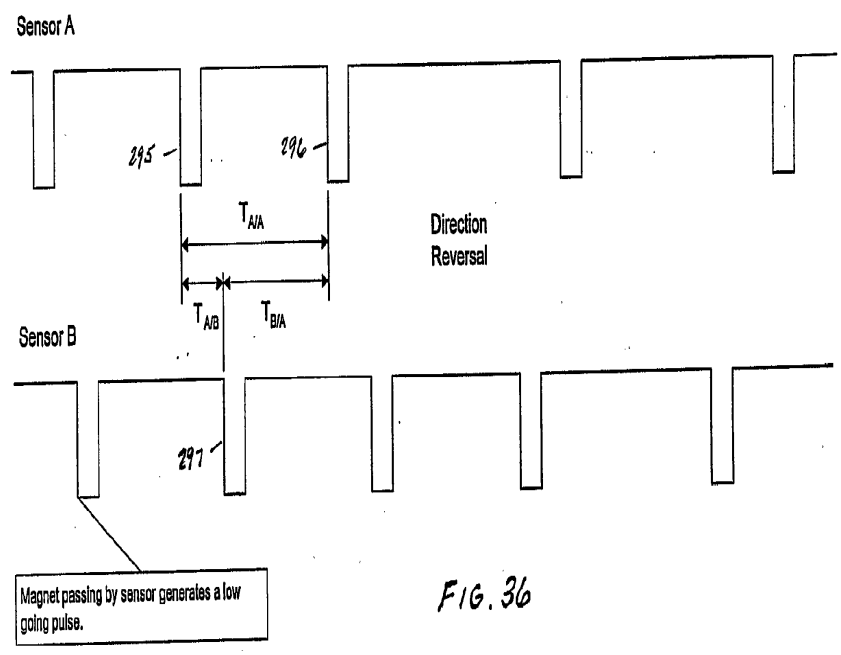


FIG. 36

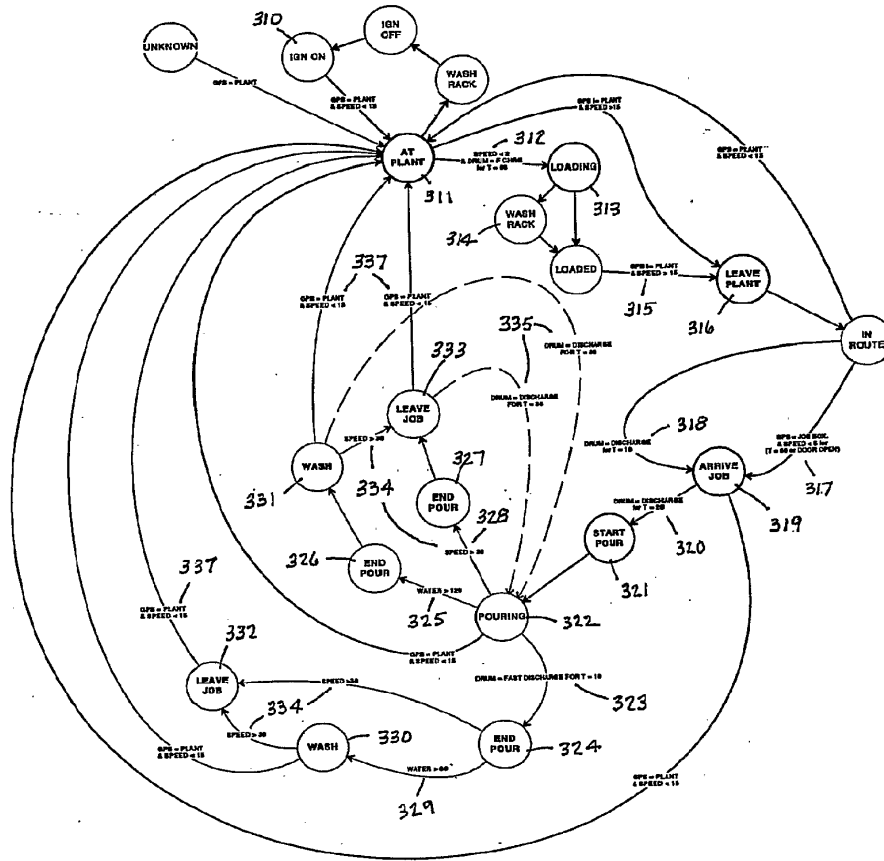


FIG. 37

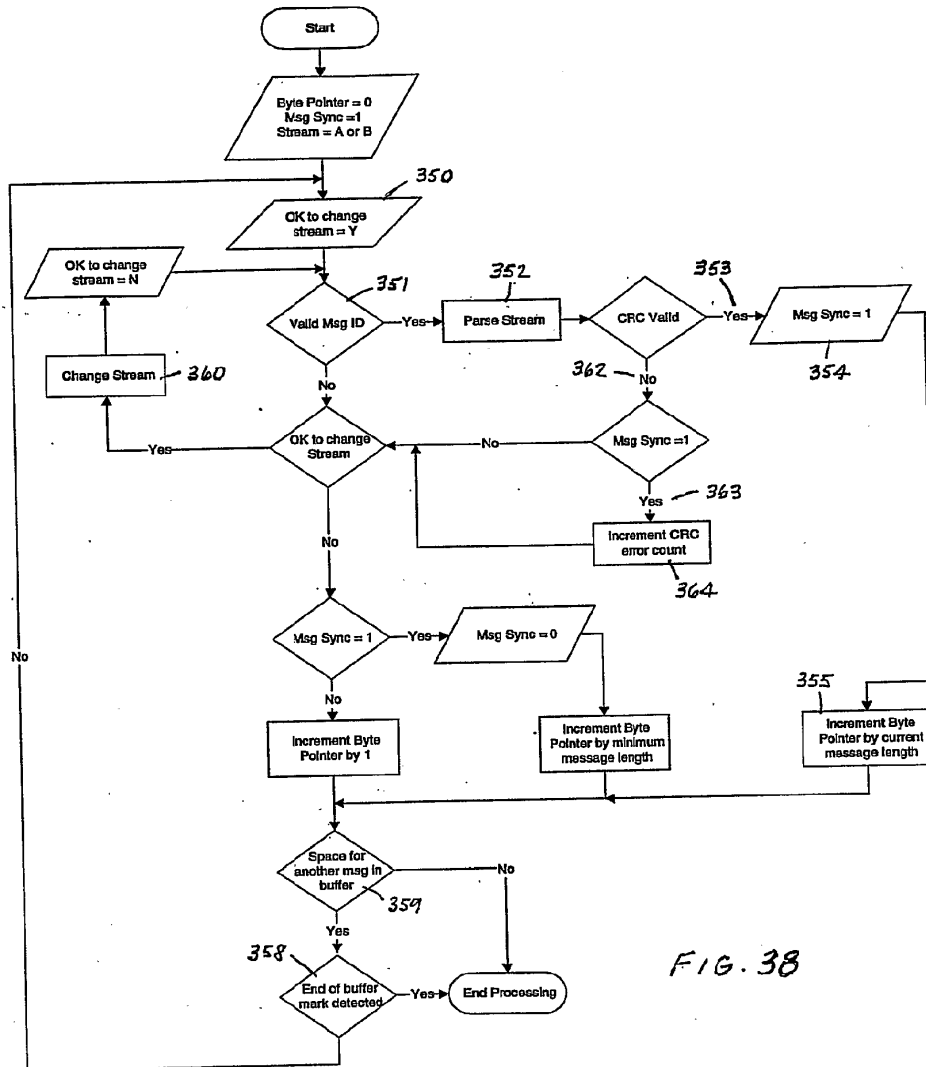


FIG. 38



INTERNATIONAL APPLICATION PUBLISHED UNDER THE PATENT COOPERATION TREATY (PCT)

|   |                  |   |
|---|------------------|---|
| <p>(51) International Patent Classification <sup>7</sup> :<br/><b>G01S 3/02, H04B 7/185</b></p>   | <p><b>A1</b></p> | <p>(11) International Publication Number: <b>WO 00/40992</b><br/>(43) International Publication Date: 13 July 2000 (13.07.00)</p>   |
| <p>(21) International Application Number: PCT/US99/29507<br/>(22) International Filing Date: 13 December 1999 (13.12.99)<br/>(30) Priority Data:<br/>09/227,764 8 January 1999 (08.01.99) US<br/>09/229,130 12 January 1999 (12.01.99) US<br/>(71) Applicant: TRUEPOSITION, INC. [US/US]; 780 Fifth Avenue, King of Prussia, PA 19406 (US).<br/>(72) Inventor: STILP, Louis, A.; 1435 Byrd Drive, Berwyn, PA 19312 (US).<br/>(74) Agents: NORRIS, Norman, L. et al.; Woodcock Washburn Kurtz Mackiewicz &amp; Norris LLP, 46th floor, One Liberty Place, Philadelphia, PA 19103 (US).</p> |                  | <p>(81) Designated States: AE, AL, AM, AT, AU, AZ, BA, BB, BG, BR, BY, CA, CH, CN, CR, CU, CZ, DE, DK, DM, EE, ES, FI, GB, GD, GE, GH, GM, HR, HU, ID, IL, IN, IS, JP, KE, KG, KP, KR, KZ, LC, LK, LR, LS, LT, LU, LV, MD, MG, MK, MN, MW, MX, NO, NZ, PL, PT, RO, RU, SD, SE, SG, SI, SK, SL, TJ, TM, TR, TT, TZ, UA, UG, UZ, VN, YU, ZA, ZW, ARIPO patent (GH, GM, KE, LS, MW, SD, SL, SZ, TZ, UG, ZW), Eurasian patent (AM, AZ, BY, KG, KZ, MD, RU, TJ, TM), European patent (AT, BE, CH, CY, DE, DK, ES, FI, FR, GB, GR, IE, IT, LU, MC, NL, PT, SE), OAPI patent (BF, BJ, CF, CG, CI, CM, GA, GN, GW, ML, MR, NE, SN, TD, TG).</p> <p><b>Published</b><br/><i>With international search report.<br/>Before the expiration of the time limit for amending the claims and to be republished in the event of the receipt of amendments.</i></p> |

(54) Title: LOCATION METHOD FOR A WIRELESS LOCATION SYSTEM

(57) Abstract

A method for use in locating a mobile transmitter in an emergency situation comprises the steps of (a) upon determining that the emergency situation exists, monitoring a bandwidth of a reverse voice channel (RVC) signal transmitted by the mobile transmitter; (b) determining (fig. 10A) whether the bandwidth exceeds a predetermined threshold; (c) if the bandwidth exceeds the predetermined threshold, measuring the location of the mobile transmitter; and (d) if the bandwidth does not exceed the predetermined threshold, performing a predetermined action to increase the bandwidth and subsequently measuring the location of the mobile transmitter.



**FOR THE PURPOSES OF INFORMATION ONLY**

Codes used to identify States party to the PCT on the front pages of pamphlets publishing international applications under the PCT.

|           |                          |           |  |           |  |           |                          |
|-----------|--------------------------|-----------|--|-----------|--|-----------|--------------------------|
| <b>AL</b> | Albania                  | <b>ES</b> | Spain                                    | <b>LS</b> | Lesotho                                      | <b>SI</b> | Slovenia                 |
| <b>AM</b> | Armenia                  | <b>FI</b> | Finland                                  | <b>LT</b> | Lithuania                                    | <b>SK</b> | Slovakia                 |
| <b>AT</b> | Austria                  | <b>FR</b> | France                                   | <b>LU</b> | Luxembourg                                   | <b>SN</b> | Senegal                  |
| <b>AU</b> | Australia                | <b>GA</b> | Gabon                                    | <b>LV</b> | Latvia                                       | <b>SZ</b> | Swaziland                |
| <b>AZ</b> | Azerbaijan               | <b>GB</b> | United Kingdom                           | <b>MC</b> | Monaco                                       | <b>TD</b> | Chad                     |
| <b>BA</b> | Bosnia and Herzegovina   | <b>GE</b> | Georgia                                  | <b>MD</b> | Republic of Moldova                          | <b>TG</b> | Togo                     |
| <b>BB</b> | Barbados                 | <b>GH</b> | Ghana                                    | <b>MG</b> | Madagascar                                   | <b>TJ</b> | Tajikistan               |
| <b>BE</b> | Belgium                  | <b>GN</b> | Guinea                                   | <b>MK</b> | The former Yugoslav<br>Republic of Macedonia | <b>TM</b> | Turkmenistan             |
| <b>BF</b> | Burkina Faso             | <b>GR</b> | Greece                                   | <b>ML</b> | Mali   | <b>TR</b> | Turkey                   |
| <b>BG</b> | Bulgaria                 | <b>HU</b> | Hungary                                  | <b>MN</b> | Mongolia                                     | <b>TT</b> | Trinidad and Tobago      |
| <b>BJ</b> | Benin                    | <b>IE</b> | Ireland                                  | <b>MR</b> | Mauritania                                   | <b>UA</b> | Ukraine                  |
| <b>BR</b> | Brazil                   | <b>IL</b> | Israel                                   | <b>MX</b> | Malawi                                       | <b>UG</b> | Uganda                   |
| <b>BY</b> | Belarus                  | <b>IS</b> | Iceland                                  | <b>NE</b> | Niger  | <b>US</b> | United States of America |
| <b>CA</b> | Canada                   | <b>IT</b> | Italy                                    | <b>NL</b> | Netherlands                                  | <b>UZ</b> | Uzbekistan               |
| <b>CF</b> | Central African Republic | <b>JP</b> | Japan                                    | <b>NO</b> | Norway                                       | <b>VN</b> | Viet Nam                 |
| <b>CG</b> | Congo                    | <b>KE</b> | Kenya                                    | <b>NZ</b> | New Zealand                                  | <b>YU</b> | Yugoslavia               |
| <b>CH</b> | Switzerland              | <b>KG</b> | Kyrgyzstan                               | <b>PL</b> | Poland                                       | <b>ZW</b> | Zimbabwe                 |
| <b>CI</b> | Côte d'Ivoire            | <b>KP</b> | Democratic People's<br>Republic of Korea | <b>PT</b> | Portugal                                     |           |                          |
| <b>CM</b> | Cameroon                 | <b>KR</b> | Republic of Korea                        | <b>RO</b> | Romania                                      |           |                          |
| <b>CN</b> | China                    | <b>KZ</b> | Kazakstan                                | <b>RU</b> | Russian Federation                           |           |                          |
| <b>CU</b> | Cuba                     | <b>LC</b> | Saint Lucia                              | <b>SD</b> | Sudan  |           |                          |
| <b>CZ</b> | Czech Republic           | <b>LI</b> | Liechtenstein                            | <b>SE</b> | Sweden                                       |           |                          |
| <b>DE</b> | Germany                  | <b>LK</b> | Sri Lanka                                | <b>SG</b> | Singapore                                    |           |                          |
| <b>DK</b> | Denmark                  | <b>LR</b> | Liberia                                  |           |  |           |                          |
| <b>EE</b> | Estonia                  |           |  |           |  |           |                          |

## LOCATION METHOD FOR A WIRELESS LOCATION SYSTEM

### CROSS REFERENCE TO RELATED APPLICATIONS

- 5 This is a continuation of U.S. Patent Application Serial No. \_\_ (attorney docket ACOM-0091), filed on January 8, 1999, entitled "Calibration for Wireless Location System."

### FIELD OF THE INVENTION

10 The present invention relates generally to methods and apparatus for locating wireless transmitters, such as those used in analog or digital cellular systems, personnel communications systems (PCS), enhanced specialized mobile radios (ESMRs), and other types of wireless communications systems. This field is now generally known as wireless location, and has application for Wireless E9-1-1, fleet management, RF optimization, and other valuable applications.

15

### BACKGROUND OF THE INVENTION

Early work relating to the present invention has been described in U.S. Patent Number 5,327,144, July 5, 1994, "Cellular Telephone Location System," which discloses a system for locating cellular telephones using novel time difference of arrival (TDOA) techniques.  
20 Further enhancements of the system disclosed in the '144 patent are disclosed in U.S. Patent Number 5,608,410, March 4, 1997, "System for Locating a Source of Bursty Transmissions." Both patents are owned by the assignee of the current invention, and both are incorporated herein by reference. The present inventors have continued to develop significant enhancements to the original inventive concepts and have developed  
25 techniques to further improve the accuracy of Wireless Location Systems while significantly reducing the cost of these systems.

Over the past few years, the cellular industry has increased the number of air interface protocols available for use by wireless telephones, increased the number of frequency  
30 bands in which wireless or mobile telephones may operate, and expanded the number of terms that refer or relate to mobile telephones to include "personal communications services", "wireless", and others. The air interface protocols now include AMPS, N-

AMPS, TDMA, CDMA, GSM, TACS, ESMR, and others. The changes in terminology and increases in the number of air interfaces do not change the basic principles and inventions discovered and enhanced by the inventors. However, in keeping with the current terminology of the industry, the inventors now call the system described herein a *Wireless Location System*.

The inventors have conducted extensive experiments with the Wireless Location System technology disclosed herein to demonstrate both the viability and value of the technology. For example, several experiments were conducted during several months of 1995 and 1996 in the cities of Philadelphia and Baltimore to verify the system's ability to mitigate multipath in large urban environments. Then, in 1996 the inventors constructed a system in Houston that was used to test the technology's effectiveness in that area and its ability to interface directly with E9-1-1 systems. Then, in 1997, the system was tested in a 350 square mile area in New Jersey and was used to locate real 9-1-1 calls from real people in trouble. Since that time, the system test has been expanded to include 125 cell sites covering an area of over 2,000 square miles. During all of these tests, techniques discussed and disclosed herein were tested for effectiveness and further developed, and the system has been demonstrated to overcome the limitations of other approaches that have been proposed for locating wireless telephones. Indeed, as of December, 1998, no other wireless location system has been installed anywhere else in the world that is capable of locating live 9-1-1 callers. The innovation of the Wireless Location System disclosed herein has been acknowledged in the wireless industry by the extensive amount of media coverage given to the system's capabilities, as well as by awards. For example, the prestigious Wireless Appy Award was granted to the system by the Cellular Telephone Industry Association in October, 1997, and the Christopher Columbus Fellowship Foundation and Discover Magazine found the Wireless Location System to be one of the top 4 innovations of 1998 out of 4,000 nominations submitted.

The value and importance of the Wireless Location System has been acknowledged by the wireless communications industry. In June 1996, the Federal Communications Commission issued requirements for the wireless communications industry to deploy location systems for use in locating wireless 9-1-1 callers, with a deadline of October

2001. The location of wireless E9-1-1 callers will save response time, save lives, and save enormous costs because of reduced use of emergency responses resources. In addition, numerous surveys and studies have concluded that various wireless applications, such as location sensitive billing, fleet management, and others, will have great commercial values  
5 in the coming years.

#### Background on Wireless Communications Systems

There are many different types of air interface protocols used for wireless communications systems. These protocols are used in different frequency bands, both in the U.S. and  
10 internationally. The frequency band does not impact the Wireless Location System's effectiveness at locating wireless telephones.

All air interface protocols use two types of "channels". The first type includes control channels that are used for conveying information about the wireless telephone or  
15 transmitter, for initiating or terminating calls, or for transferring bursty data. For example, some types of short messaging services transfer data over the control channel. In different air interfaces, control channels are known by different terminology, but the use of the control channels in each air interface is similar. Control channels generally have identifying information about the wireless telephone or transmitter contained in the  
20 transmission.

The second type includes voice channels that are typically used for conveying voice communications over the air interface. These channels are only used after a call has been set up using the control channels. Voice channels will typically use dedicated resources  
25 within the wireless communications system whereas control channels will use shared resources. This distinction will generally make the use of control channels for wireless location purposes more cost effective than the use of voice channels, although there are some applications for which regular location on the voice channel is desired. Voice channels generally do not have identifying information about the wireless telephone or  
30 transmitter in the transmission. Some of the differences in the air interface protocols are discussed below:

AMPS – This is the original air interface protocol used for cellular communications in the U.S. In the AMPS system, separate dedicated channels are assigned for use by control channels (RCC). According to the TIA/EIA Standard IS-553A, every control channel block must begin at cellular channel 333 or 334, but the block may be of variable length.

5 In the U.S., by convention, the AMPS control channel block is 21 channels wide, but the use of a 26-channel block is also known. A reverse voice channel (RVC) may occupy any channel that is not assigned to a control channel. The control channel modulation is FSK (frequency shift keying), while the voice channels are modulated using FM (frequency modulation).

10

N-AMPS – This air interface is an expansion of the AMPS air interface protocol, and is defined in EIA/TIA standard IS-88. The control channels are substantially the same as for AMPS, however, the voice channels are different. The voice channels occupy less than 10 KHz of bandwidth, versus the 30 KHz used for AMPS, and the modulation is FM.

15

TDMA – This interface is also known D-AMPS, and is defined in EIA/TIA standard IS-136. This air interface is characterized by the use of both frequency and time separation. Control channels are known as Digital Control Channels (DCCH) and are transmitted in bursts in timeslots assigned for use by DCCH. Unlike AMPS, DCCH may be assigned

20 anywhere in the frequency band, although there are generally some frequency assignments that are more attractive than others based upon the use of probability blocks. Voice channels are known as Digital Traffic Channels (DTC). DCCH and DTC may occupy the same frequency assignments, but not the same timeslot assignment in a given frequency assignment. DCCH and DTC use the same modulation scheme, known as  $\pi/4$  DQPSK

25 (differential quadrature phase shift keying). In the cellular band, a carrier may use both the AMPS and TDMA protocols, as long as the frequency assignments for each protocol are kept separated.

CDMA – This air interface is defined by EIA/TIA standard IS-95A. This air interface is

30 characterized by the use of both frequency and code separation. However, because adjacent cell sites may use the same frequency sets, CDMA is also characterized by very careful power control. This careful power control leads to a situation known to those

skilled in the art as the near-far problem, which makes wireless location difficult for most approaches to function properly. Control channels are known as Access Channels, and voice channels are known as Traffic Channels. Access and Traffic Channels may share the same frequency band, but are separated by code. Access and Traffic Channels use the same modulation scheme, known as OQPSK.

GSM - This air interface is defined by the international standard Global System for Mobile Communications. Like TDMA, GSM is characterized by the use of both frequency and time separation. The channel bandwidth is 200 KHz, which is wider than the 30 KHz used for TDMA. Control channels are known as Standalone Dedicated Control Channels (SDCCH), and are transmitted in bursts in timeslots assigned for use by SDCCH. SDCCH may be assigned anywhere in the frequency band. Voice channels are known as Traffic Channels (TCH). SDCCH and TCH may occupy the same frequency assignments, but not the same timeslot assignment in a given frequency assignment. SDCCH and TCH use the same modulation scheme, known as GMSK.

Within this specification the reference to any one of the air interfaces shall automatically refer to all of the air interfaces, unless specified otherwise. Additionally, a reference to control channels or voice channels shall refer to all types of control or voice channels, whatever the preferred terminology for a particular air interface. Finally, there are many more types of air interfaces used throughout the world, and there is no intent to exclude any air interface from the inventive concepts described within this specification. Indeed, those skilled in the art will recognize other interfaces used elsewhere are derivatives of or similar in class to those described above.

The preferred embodiments of the inventions disclosed herein have many advantages over other techniques for locating wireless telephones. For example, some of these other techniques involve adding GPS functionality to telephones, which requires that significant changes be made to the telephones. The preferred embodiments disclosed herein do not require any changes to wireless telephones, and so they can be used in connection with the current installed base of over 65 million wireless telephones in the U.S. and 250 million wireless telephones worldwide.

**SUMMARY OF THE INVENTION**

In view of the difficulties presented by the limited bandwidth of the FM voice and supervisory audio tone (SAT) reverse voice channel signals, a primary object of the present invention is to provide an improved method by which reverse voice channel (RVC) signals may be utilized to locate a mobile transmitter, particularly in an emergency situation. Another object of the invention is to provide a location method that allows the location system to avoid making location estimates using RVC signals in situations in which it is likely that the measurement will not meet prescribed accuracy and reliability requirements. This saves system resources and improves the location system's overall efficiency.

The improved method is based upon two techniques. The first technique includes monitoring the instantaneous bandwidth of the transmission in the voice channel to determine when the bandwidth is at a level that enables the wireless location system to make a high quality estimate of location. The second technique includes forcing the mobile unit to temporarily increase its bandwidth through a manual or automatic action.

According to the present invention, a method for use in locating a mobile transmitter in an emergency situation comprises the steps of (a) upon determining that the emergency situation exists, monitoring the bandwidth of a reverse voice channel (RVC) signal transmitted by the mobile transmitter; (b) determining whether the bandwidth exceeds a predetermined threshold; (c) if the bandwidth exceeds the predetermined threshold, measuring the location of the mobile transmitter; and (d) if the bandwidth does not exceed the predetermined threshold, performing a predetermined action to increase the bandwidth and subsequently measuring the location of the mobile transmitter. In a presently preferred embodiment of the invention, one predetermined action comprises requesting the user to take an action to cause the mobile transmitter to transmit an RVC signal comprising a prescribed number of digits. For example, the predetermined action may comprise asking the user to dial a 9-digit number. In one exemplary implementation, the predetermined action comprises asking an emergency dispatcher to instruct the user to dial the 9-digit number.

Moreover, in a presently preferred embodiment, the predetermined threshold is within the range of approximately +/-8 to +/-12 KHz, and preferably is approximately +/-10 KHz. In another preferred embodiment of the invention, the wireless location system instructs the wireless switch (MSO) to send an audit command to the mobile telephone. The mobile transmitter will respond to the audit command with an audit response message.

Other details of the invention are described below.

10 **BRIEF DESCRIPTION OF THE DRAWINGS**

Figures 1 and 1A schematically depict a Wireless Location System in accordance with the present invention.

Figure 2 schematically depicts a Signal Collection System (SCS) 10 in accordance with the present invention.

Figure 2A schematically depicts a receiver module 10-2 employed by the Signal Collection System.

20 Figures 2B and 2C schematically depict alternative ways of coupling the receiver module(s) 10-2 to the antennas 10-1.

Figure 2C-1 is a flowchart of a process employed by the Wireless Location System when using narrowband receiver modules.

25 Figure 2D schematically depicts a DSP module 10-3 employed in the Signal Collection System in accordance with the present invention.

Figure 2E is a flowchart of the operation of the DSP module(s) 10-3, and Figure 2E-1 is a flowchart of the process employed by the DSP modules for detecting active channels.



Figure 2F schematically depicts a Control and Communications Module 10-5 in accordance with the present invention.

5 Figures 2G-2J depict aspects of the presently preferred SCS calibration methods. Figure 2G is a schematic illustration of baselines and error values used to explain an external calibration method in accordance with the present invention. Figure 2H is a flowchart of an internal calibration method. Figure 2I is an exemplary transfer function of an AMPS control channel and Figure 2J depicts an exemplary comb signal.

10 Figures 2K and 2L are flowcharts of two methods for monitoring performance of a Wireless Location System in accordance with the present invention.

Figure 3 schematically depicts a TDOA Location Processor 12 in accordance with the present invention.

15

Figure 3A depicts the structure of an exemplary network map maintained by the TLP controllers in accordance with the present invention.

20 Figures 4 and 4A schematically depict different aspects of an Applications Processor 14 in accordance with the present invention.

Figure 5 is a flowchart of a central station-based location processing method in accordance with the present invention.

25 Figure 6 is a flowchart of a station-based location processing method in accordance with the present invention.

Figure 7 is a flowchart of a method for determining, for each transmission for which a location is desired, whether to employ central or station-based processing.

30

Figure 8 is a flowchart of a dynamic process used to select cooperating antennas and SCS's 10 used in location processing.

Figure 9 is diagram that is referred to below in explaining a method for selecting a candidate list of SCS's and antennas using a predetermined set of criteria.

- 5 Figures 10A and 10B are flowcharts of alternative methods for increasing the bandwidth of a transmitted signal to improve location accuracy.

Figures 11A-11C are signal flow diagrams and Figure 11D is a flowchart, and they are used to explain an inventive method for combining multiple statistically independent  
10 location estimates to provide an estimate with improved accuracy.

Figures 12A and 12B are a block diagram and a graph, respectively, for explaining a bandwidth synthesis method.

15 **DETAILED DESCRIPTION OF PREFERRED EMBODIMENTS**

The Wireless Location System (Wireless Location System) operates as a passive overlay to a wireless communications system, such as a cellular, PCS, or ESMR system, although the concepts are not limited to just those types of communications systems. Wireless communications systems are generally not suitable for locating wireless devices because  
20 the designs of the wireless transmitters and cell sites do not include the necessary functionality to achieve accurate location. Accurate location in this application is defined as accuracy of 100 to 400 feet RMS (root mean square). This is distinguished from the location accuracy that can be achieved by existing cell sites, which is generally limited to the radius of the cell site. In general, cell sites are not designed or programmed to  
25 cooperate between and among themselves to determine wireless transmitter location. Additionally, wireless transmitters such as cellular and PCS telephones are designed to be low cost and therefore generally do not have locating capability built-in. The Wireless Location System is designed to be a low cost addition to a wireless communications system that involves minimal changes to cell sites and no changes at all to standard  
30 wireless transmitters. The Wireless Location System is passive because the it does not contain transmitters, and therefore cannot cause interference of any kind to the wireless

communications system. The Wireless Location System uses only its own specialized receivers at cell sites or other receiving locations.

Overview of Wireless Location System (Wireless Location System)

5 As shown in Figure 1, the Wireless Location System has four major kinds of subsystems: the Signal Collection Systems (SCS's) 10, the TDOA Location Processors (TLP's) 12, the Application Processors (AP's) 14, and the Network Operations Console (NOC) 16. Each SCS is responsible for receiving the RF signals transmitted by the wireless transmitters on both control channels and voice channels. In general, each SCS is preferably installed at a  
10 wireless carrier's cell site, and therefore operates in parallel to a base station. Each TLP 12 is responsible for managing a network of SCS's 10 and for providing a centralized pool of digital signal processing (DSP) resources that can be used in the location calculations. The SCS's 10 and the TLP's 12 operate together to determine the location of the wireless transmitters, as will be discussed more fully below. Digital signal processing is the  
15 preferable manner in which to process radio signals because DSP's are relatively low cost, provide consistent performance, and are easily re-programmable to handle many different tasks. Both the SCS's 10 and TLP's 12 contain a significant amount of DSP resources, and the software in these systems can operate dynamically to determine where to perform a particular processing function based upon tradeoffs in processing time, communications  
20 time, queuing time, and cost. Each TLP 12 exists centrally primarily to reduce the overall cost of implementing the Wireless Location System, although the techniques discussed herein are not limited to the preferred architecture shown. That is, DSP resources can be relocated within the Wireless Location System without changing the basic concepts and functionality disclosed.

25

The AP's 14 are responsible for managing all of the resources in the Wireless Location System, including all of the SCS's 10 and TLP's 12. Each AP 14 also contains a specialized database that contains "triggers" for the Wireless Location System. In order to conserve resources, the Wireless Location System can be programmed to locate only  
30 certain pre-determined types of transmissions. When a transmission of a pre-determined type occurs, then the Wireless Location System is triggered to begin location processing. Otherwise, the Wireless Location System may be programmed to ignore the transmission.

Each AP 14 also contains applications interfaces that permit a variety of applications to securely access the Wireless Location System. These applications may, for example, access location records in real time or non-real time, create or delete certain type of triggers, or cause the Wireless Location System to take other actions. Each AP 14 is also  
5 capable of certain post-processing functions that allow the AP 14 to combine a number of location records to generate extended reports or analyses useful for applications such as traffic monitoring or RF optimization.

The NOC 16 is a network management system that provides operators of the Wireless  
10 Location System easy access to the programming parameters of the Wireless Location System. For example, in some cities, the Wireless Location System may contain many hundreds or even thousands of SCS's 10. The NOC is the most effective way to manage a large Wireless Location System, using graphical user interface capabilities. The NOC will also receive real time alerts if certain functions within the Wireless Location System are  
15 not operating properly. These real time alerts can be used by the operator to take corrective action quickly and prevent a degradation of location service. Experience with trials of the Wireless Location System show that the ability of the system to maintain good location accuracy over time is directly related to the operator's ability to keep the system operating within its predetermined parameters.

20 Readers of U.S. Patents 5,327,144 and 5,608,410 and this specification will note similarities between the respective systems. Indeed, the system disclosed herein is significantly based upon and also significantly enhanced from the system described in those previous patents. For example, the SCS 10 has been expanded and enhanced from  
25 the Antenna Site System described in 5,608,410. The SCS 10 now has the capability to support many more antennas at a single cell site, and further can support the use of extended antennas as described below. This enables the SCS 10 to operate with the sector cell sites now commonly used. The SCS 10 can also transfer data from multiple antennas at a cell site to the TLP 12 instead of always combining data from multiple  
30 antennas before transfer. Additionally, the SCS 10 can support multiple air interface protocols thereby allowing the SCS 10 to function even as a wireless carrier continually changes the configuration of its system.

The TLP 12 is similar to the Central Site System disclosed in 5,608,410, but has also been expanded and enhanced. For example, the TLP 12 has been made scaleable so that the amount of DSP resources required by each TLP 12 can be appropriately scaled to match the number of locations per second required by customers of the Wireless Location System. In order to support scaling for different Wireless Location System capacities, a networking scheme has been added to the TLP 12 so that multiple TLP's 12 can cooperate to share RF data across wireless communication system network boundaries. Additionally, the TLP 12 has been given control means to determine the SCS's 10, and more importantly the antennas at each of the SCS's 10, from which the TLP 12 is to receive data in order to process a specific location. Previously, the Antenna Site Systems automatically forwarded data to the Central Site System, whether requested or not by the Central Site System. Furthermore, the SCS 10 and TLP 12 combined have been designed with additional means for removing multipath from the received transmissions.

15

The Database Subsystem of the Central Site System has been expanded and developed into the AP 14. The AP 14 can support a greater variety of applications than previously disclosed in 5,608,410, including the ability to post-process large volumes of location records from multiple wireless transmitters. This post-processed data can yield, for example, very effective maps for use by wireless carriers to improve and optimize the RF design of the communications systems. This can be achieved, for example, by plotting the locations of all of the callers in an area and the received signal strengths at a number of cell sites. The carrier can then determine whether each cell site is, in fact, serving the exact coverage area desired by the carrier. The AP 14 can also now store location records anonymously, that is, with the MIN and/or other identity information removed from the location record, so that the location record can be used for RF optimization or traffic monitoring without causing concerns about an individual user's privacy.

20

As shown in Figure 1A, a presently preferred implementation of the Wireless Location System includes a plurality of SCS regions each of which comprises multiple SCS's 10. For example, "SCS Region 1" includes SCS's 10A and 10B (and preferably others, not shown) that are located at respective cell sites and share antennas with the base stations at

25

those cell sites. Drop and insert units 11A and 11B are used to interface fractional T1/E1 lines to full T1/E1 lines, which in turn are coupled to a digital access and control system (DACS) 13A. The DACS 13A and another DACS 13B are used in the manner described more fully below for communications between the SCS's 10A, 10B, etc., and multiple  
5 TLP's 12A, 12B, etc. As shown, the TLP's are typically collocated and interconnected via an Ethernet network (backbone) and a second, redundant Ethernet network. Also coupled to the Ethernet networks are multiple AP's 14A and 14B, multiple NOC's 16A and 16B, and a terminal server 15. Routers 19A and 19B are used to couple one Wireless Location System to one or more other Wireless Location System(s).

10

#### Signal Collection System 10

Generally, cell sites will have one of the following antenna configurations: (i) an omnidirectional site with 1 or 2 receive antennas or (ii) a sectorized site with 1, 2, or 3 sectors, and with 1 or 2 receive antennas used in each sector. As the number of cell sites  
15 has increased in the U.S. and internationally, sectorized cell sites have become the predominant configuration. However, there are also a growing number of micro-cells and pico-cells, which can be omnidirectional. Therefore, the SCS 10 has been designed to be configurable for any of these typical cell sites and has been provided with mechanisms to employ any number of antennas at a cell site.

20

The basic architectural elements of the SCS 10 remain the same as for the Antenna Site System described in 5,608,410, but several enhancements have been made to increase the flexibility of the SCS 10 and to reduce the commercial deployment cost of the system. The most presently preferred embodiment of the SCS 10 is described herein. The SCS 10, an  
25 overview of which is shown in Figure 2, includes digital receiver modules 10-2A through 10-2C; DSP modules 10-3A through 10-3C; a serial bus 10-4, a control and communications module 10-5; a GPS module 10-6; and a clock distribution module 10-7. The SCS 10 has the following external connections: power, fractional T1/E1 communications, RF connections to antennas, and a GPS antenna connection for the  
30 timing generation (or clock distribution) module 10-7. The architecture and packaging of the SCS 10 permit it to be physically collocated with cell sites (which is the most common installation place), located at other types of towers (such as FM, AM, two-way emergency

communications, television, etc.), or located at other building structures (such as rooftops, silos, etc.).

#### Timing Generation

- 5 The Wireless Location System depends upon the accurate determination of time at all SCS's 10 contained within a network. Several different timing generation systems have been described in previous disclosures, however the most presently preferred embodiment is based upon an enhanced GPS receiver 10-6. The enhanced GPS receiver differs from most traditional GPS receivers in that the receiver contains algorithms that remove some  
10 of the timing instability of the GPS signals, and guarantees that any two SCS's 10 contained within a network can receive timing pulses that are within approximately ten nanoseconds of each other. These enhanced GPS receivers are now commercially available, and further reduce some of the time reference related errors that were observed in previous implementations of wireless location systems. While this enhanced GPS  
15 receiver can produce a very accurate time reference, the output of the receiver may still have an unacceptable phase noise. Therefore, the output of the receiver is input to a low phase noise, crystal oscillator-driven phase locked loop circuit that can now produce 10 MHz and one pulse per second (PPS) reference signals with less than 0.01 degrees RMS of phase noise, and with the pulse output at any SCS 10 in a Wireless Location System  
20 network within ten nanoseconds of any other pulse at another SCS 10. This combination of enhanced GPS receiver, crystal oscillator, and phase locked loop is now the most preferred method to produce stable time and frequency reference signals with low phase noise.
- 25 The SCS 10 has been designed to support multiple frequency bands and multiple carriers with equipment located at the same cell site. This can take place by using multiple receivers internal to a single SCS chassis, or by using multiple chassis each with separate receivers. In the event that multiple SCS chassis are placed at the same cell site, the SCS's 10 can share a single timing generation/clock distribution circuit 10-7 and thereby reduce  
30 overall system cost. The 10 MHz and one PPS output signals from the timing generation circuit are amplified and buffered internal to the SCS 10, and then made available via external connectors. Therefore a second SCS can receive its timing from a first SCS using

the buffered output and the external connectors. These signals can also be made available to base station equipment collocated at the cell site. This might be useful to the base station, for example, in improving the frequency re-use pattern of a wireless communications system.

5

Receiver Module 10-2 (Wideband Embodiment)

When a wireless transmitter makes a transmission, the Wireless Location System must receive the transmission at multiple SCS's 10 located at multiple geographically dispersed cell sites. Therefore, each SCS 10 has the ability to receive a transmission on any RF channel on which the transmission may originate. Additionally, since the SCS 10 is capable of supporting multiple air interface protocols, the SCS 10 also supports multiple types of RF channels. This is in contrast to most current base station receivers, which typically receive only one type of channel and are usually capable of receiving only on select RF channels at each cell site. For example, a typical TDMA base station receiver will only support 30 KHz wide channels, and each receiver is programmed to receive signals on only a single channel whose frequency does not change often (i.e. there is a relatively fixed frequency plan). Therefore, very few TDMA base station receivers would receive a transmission on any given frequency. As another example, even though some GSM base station receivers are capable of frequency hopping, the receivers at multiple base stations are generally not capable of simultaneously tuning to a single frequency for the purpose of performing location processing. In fact, the receivers at GSM base stations are programmed to frequency hop to avoid using an RF channel that is being used by another transmitter so as to minimize interference.

25 The SCS receiver module 10-2 is preferably a dual wideband digital receiver that can receive the entire frequency band and all of the RF channels of an air interface. For cellular systems in the U.S., this receiver module is either 15 MHz wide or 25 MHz wide so that all of the channels of a single carrier or all of the channels of both carriers can be received. This receiver module has many of the characteristics of the receiver previously described in Patent Number 5,608,410, and Figure 2A is a block diagram of the currently preferred embodiment. Each receiver module contains an RF tuner section 10-2-1, a data interface and control section 10-2-2 and an analog to digital conversion section 10-2-3.

15



The RF tuner section 10-2-1 includes two full independent digital receivers (including Tuner #1 and Tuner #2) that convert the analog RF input from an external connector into a digitized data stream. Unlike most base station receivers, the SCS receiver module does not perform diversity combining or switching. Rather, the digitized signal from each independent receiver is made available to the location processing. The present inventors have determined that there is an advantage to the location processing, and especially the multipath mitigation processing, to independently process the signals from each antenna rather than perform combining on the receiver module.

The receiver module 10-2 performs, or is coupled to elements that perform, the following functions: automatic gain control (to support both nearby strong signals and far away weak signals), bandpass filtering to remove potentially interfering signals from outside of the RF band of interest, synthesis of frequencies needed for mixing with the RF signals to create an IF signal that can be sampled, mixing, and analog to digital conversion (ADC) for sampling the RF signals and outputting a digitized data stream having an appropriate bandwidth and bit resolution. The frequency synthesizer locks the synthesized frequencies to the 10 MHz reference signal from the clock distribution/timing generation module 10-7 (Figure 2). All of the circuits used in the receiver module maintain the low phase noise characteristics of the timing reference signal. The receiver module preferably has a spurious free dynamic range of at least 80 dB.

The receiver module 10-2 also contains circuits to generate test frequencies and calibration signals, as well as test ports where measurements can be made by technicians during installation or troubleshooting. Various calibration processes are described in further detail below. The internally generated test frequencies and test ports provide an easy method for engineers and technicians to rapidly test the receiver module and diagnose any suspected problems. This is also especially useful during the manufacturing process.

One of the advantages of the Wireless Location System described herein is that no new antennas are required at cell sites. The Wireless Location System can use the existing antennas already installed at most cell sites, including both omni-directional and sectored antennas. This feature can result in significant savings in the installation and maintenance

costs of the Wireless Location System versus other approaches that have been described in the prior art. The SCS's digital receivers 10-2 can be connected to the existing antennas in two ways, as shown in Figures 2B and 2C, respectively. In Figure 2B, the SCS receivers 10-2 are connected to the existing cell site multi-coupler or RF splitter. In this manner, the SCS 10 uses the cell site's existing low noise pre-amplifier, band pass filter, and multi-coupler or RF splitter. This type of connection usually limits the SCS 10 to supporting the frequency band of a single carrier. For example, an A-side cellular carrier will typically use the band pass filter to block signals from customers of the B-side carrier, and vice versa.

10 In Figure 2C, the existing RF path at the cell site has been interrupted, and a new pre-amplifier, band pass filter, and RF splitter has been added as part of the Wireless Location System. The new band pass filter will pass multiple contiguous frequency bands, such as both the A-side and B-side cellular carriers, thereby allowing the Wireless Location System to locate wireless transmitters using both cellular systems but using the antennas from a single cell site. In this configuration, the Wireless Location System uses matched RF components at each cell site, so that the phase versus frequency responses are identical. This is in contrast to existing RF components, which may be from different manufacturers or using different model numbers at various cell sites. Matching the response characteristics of RF components reduces a possible source of error for the location processing, although the Wireless Location System has the capability to compensate for these sources of error. Finally, the new pre-amplifier installed with the Wireless Location System will have a very low noise figure to improve the sensitivity of the SCS 10 at a cell site. The overall noise figure of the SCS digital receivers 10-2 is dominated by the noise figure of the low noise amplifiers. Because the Wireless Location System can use weak signals in location processing, whereas the base station typically cannot process weak signals, the Wireless Location System can significantly benefit from a high quality, very low noise amplifier.

30 In order to improve the ability of the Wireless Location System to accurately determine TDQA for a wireless transmission, the phase versus frequency response of the cell site's RF components are determined at the time of installation and updated at other certain

times and then stored in a table in the Wireless Location System. This can be important because, for example, the band pass filters and/or multi-couplers made by some manufacturers have a steep and non-linear phase versus frequency response near the edge of the pass band. If the edge of the pass band is very near to or coincident with the reverse control or voice channels, then the Wireless Location System would make incorrect measurements of the transmitted signal's phase characteristics if the Wireless Location System did not correct the measurements using the stored characteristics. This becomes even more important if a carrier has installed multi-couplers and/or band pass filters from more than one manufacturer, because the characteristics at each site may be different. In addition to measuring the phase versus frequency response, other environmental factors may cause changes to the RF path prior to the ADC. These factors require occasional and sometimes periodic calibration in the SCS 10.

#### Alternative Narrowband Embodiment of Receiver Module 10-2

In addition or as an alternative to the wideband receiver module, the SCS 10 also supports a narrowband embodiment of the receiver module 10-2. In contrast to the wideband receiver module that can simultaneously receive all of the RF channels in use by a wireless communications system, the narrowband receiver can only receive one or a few RF channels at a time. For example, the SCS 10 supports a 60 KHz narrowband receiver for use in AMPS/TDMA systems, covering two contiguous 30 KHz channels. This receiver is still a digital receiver as described for the wideband module, however the frequency synthesizing and mixing circuits are used to dynamically tune the receiver module to various RF channels on command. This dynamic tuning can typically occur in one millisecond or less, and the receiver can dwell on a specific RF channel for as long as required to receive and digitize RF data for location processing.

The purpose of the narrowband receiver is to reduce the implementation cost of a Wireless Location System from the cost that is incurred with wideband receivers. Of course, there is some loss of performance, but the availability of these multiple receivers permits wireless carriers to have more cost/performance options. Additional inventive functions and enhancements have been added to the Wireless Location System to support this new type of narrowband receiver. When the wideband receiver is being used, all RF channels are

received continuously at all SCS's 10, and subsequent to the transmission, the Wireless Location System can use the DSP's 10-3 (Figure 2) to dynamically select any RF channel from the digital memory. With the narrowband receiver, the Wireless Location System must ensure *a priori* that the narrowband receivers at multiple cell sites are simultaneously  
5 tuned to the same RF channel so that all receivers can simultaneously receive, digitize and store the same wireless transmission. For this reason, the narrowband receiver is generally used only for locating voice channel transmissions, which can be known *a priori* to be making a transmission. Since control channel transmissions can occur asynchronously at any time, the narrowband receiver may not be tuned to the correct channel to receive the  
10 transmission.

When the narrowband receivers are used for locating AMPS voice channel transmissions, the Wireless Location System has the ability to temporarily change the modulation characteristics of the AMPS wireless transmitter to aid location processing. This may be  
15 necessary because AMPS voice channels are only FM modulated with the addition of a low level supervisory tone known as SAT. As is known in the art, the Cramer-Rao lower bound of AMPS FM modulation is significantly worse than the Manchester encoded FSK modulation used for AMPS reverse channels and "blank and burst" transmissions on the voice channel. Further, AMPS wireless transmitters may be transmitting with significantly  
20 reduced energy if there is no modulating input signal (i.e., no one is speaking). To improve the location estimate by improving the modulation characteristics without depending on the existence or amplitude of an input modulating signal, the Wireless Location System can cause an AMPS wireless transmitter to transmit a "blank and burst" message at a point in time when the narrowband receivers at multiple SCS's 10 are tuned to the RF channel  
25 on which the message will be sent. This is further described later.

The Wireless Location System performs the following steps when using the narrowband receiver module (see the flowchart of Figure 2C-1):

30 a first wireless transmitter is *a priori* engaged in transmitting on a particular RF channel;

the Wireless Location System triggers to make a location estimate of the first wireless transmitter (the trigger may occur either internally or externally via a command/response interface);

5 the Wireless Location System determines the cell site, sector, RF channel, timeslot, long code mask, and encryption key (all information elements may not be necessary for all air interface protocols) currently in use by the first wireless transmitter;

10 the Wireless Location System tunes an appropriate first narrowband receiver at an appropriate first SCS 10 to the RF channel and timeslot at the designated cell site and sector, where appropriate typically means both available and collocated or in closest proximity;

the first SCS 10 receives a time segment of RF data, typically ranging from a few microseconds to tens of milliseconds, from the first narrowband receiver and evaluates the transmission's power, SNR, and modulation characteristics;

15 if the transmission's power or SNR is below a predetermined threshold, the Wireless Location System waits a predetermined length of time and then returns to the above third step (where the Wireless Location System determines the cell site, sector, etc.);

20 if the transmission is an AMPS voice channel transmission and the modulation is below a threshold, then the Wireless Location System commands the wireless communications system to send a command to the first wireless transmitter to cause a "blank and burst" on the first wireless transmitter;

the Wireless Location System requests the wireless communications system to prevent hand-off of the wireless transmitter to another RF channel for a predetermined

25 length of time;

the Wireless Location System receives a response from the wireless communications system indicating the time period during which the first wireless transmitter will be prevented from handing-off, and if commanded, the time period during which the wireless communications system will send a command to the first wireless

30 transmitter to cause a "blank and burst";

the Wireless Location System determines the list of antennas that will be used in location processing (the antenna selection process is described below);

the Wireless Location System determines the earliest Wireless Location System timestamp at which the narrowband receivers connected to the selected antennas are available to begin simultaneously collecting RF data from the RF channel currently in use by the first wireless transmitter;

5 based upon the earliest Wireless Location System timestamp and the time periods in the response from the wireless communications system, the Wireless Location System commands the narrowband receivers connected to the antennas that will be used in location processing to tune to the cell site, sector, and RF channel currently in use by the first wireless transmitter and to receive RF data for a predetermined

10 dwell time (based upon the bandwidth of the signal, SNR, and integration requirements);

the RF data received by the narrowband receivers are written into the dual port memory;

location processing on the received RF data commences, as described in Patent Nos.

15 5,327,144 and 5,608,410 and in sections below;

the Wireless Location System again determines the cell site, sector, RF channel, timeslot, long code mask, and encryption key currently in use by the first wireless transmitter;

if the cell site, sector, RF channel, timeslot, long code mask, and encryption key

20 currently in use by the first wireless transmitter has changed between queries (i.e. before and after gathering the RF data) the Wireless Location System ceases location processing, causes an alert message that location processing failed because the wireless transmitter changed transmission status during the period of time in which RF data was being received, and re-triggers this entire process;

25 location processing on the received RF data completes in accordance with the steps described below.

The determination of the information elements including cell site, sector, RF channel, timeslot, long code mask, and encryption key (all information elements may not be

30 necessary for all air interface protocols) is typically obtained by the Wireless Location System through a command / response interface between the Wireless Location System and the wireless communications system.

The use of the narrowband receiver in the manner described above is known as random tuning because the receivers can be directed to any RF channel on command from the system. One advantage to random tuning is that locations are processed only for those wireless transmitters for which the Wireless Location System is triggered. One disadvantage to random tuning is that various synchronization factors, including the interface between the wireless communications system and the Wireless Location System and the latency times in scheduling the necessary receivers throughout the system, can limit the total location processing throughput. For example, in a TDMA system, random tuning used throughout the Wireless Location System will typically limit location processing throughput to about 2.5 locations per second per cell site sector.

Therefore, the narrowband receiver also supports another mode, known as automatic sequential tuning, which can perform location processing at a higher throughput. For example, in a TDMA system, using similar assumptions about dwell time and setup time as for the narrowband receiver operation described above, sequential tuning can achieve a location processing throughput of about 41 locations per second per cell site sector, meaning that all 395 TDMA RF channels can be processed in about 9 seconds. This increased rate can be achieved by taking advantage of, for example, the two contiguous RF channels that can be received simultaneously, location processing all three TDMA timeslots in an RF channel, and eliminating the need for synchronization with the wireless communications system. When the Wireless Location System is using the narrowband receivers for sequential tuning, the Wireless Location System has no knowledge of the identity of the wireless transmitter because the Wireless Location System does not wait for a trigger, nor does the Wireless Location System query the wireless communications system for the identity information prior to receiving the transmission. In this method, the Wireless Location System sequences through every cell site, RF channel and time slot, performs location processing, and reports a location record identifying a time stamp, cell site, RF channel, time slot, and location. Subsequent to the location record report, the Wireless Location System and the wireless communications system match the location records to the wireless communications system's data indicating which wireless transmitters were in use at the time, and which cell sites, RF channels, and time slots were

used by each wireless transmitter. Then, the Wireless Location System can retain the location records for wireless transmitters of interest, and discard those location records for the remaining wireless transmitters.

5 Digital Signal Processor Module 10-3

The SCS digital receiver modules 10-2 output a digitized RF data stream having a specified bandwidth and bit resolution. For example, a 15 MHz embodiment of the wideband receiver may output a data stream containing 60 million samples per second, at a resolution of 14 bits per sample. This RF data stream will contain all of the RF channels  
10 that are used by the wireless communications system. The DSP modules 10-3 receive the digitized data stream, and can extract any individual RF channel through digital mixing and filtering. The DSP's can also reduce the bit resolution upon command from the Wireless Location System, as needed to reduce the bandwidth requirements between the SCS 10 and TLP 12. The Wireless Location System can dynamically select the bit  
15 resolution at which to forward digitized baseband RF data, based upon the processing requirements for each location. DSP's are used for these functions to reduce the systemic errors that can occur from mixing and filtering with analog components. The use of DSP's allows perfect matching in the processing between any two SCS's 10.

20 A block diagram of the DSP module 10-3 is shown in Figure 2D, and the operation of the DSP module is depicted by the flowchart of Figure 2E. As shown in Figure 2D, the DSP module 10-3 comprises the following elements: a pair of DSP elements 10-3-1A and 10-3-1B, referred to collectively as a "first" DSP; serial to parallel converters 10-3-2; dual port memory elements 10-3-3; a second DSP 10-3-4; a parallel to serial converter; a FIFO  
25 buffer; a DSP 10-3-5 (including RAM) for detection, another DSP 10-3-6 for demodulation, and another DSP 10-3-7 for normalization and control; and an address generator 10-3-8. In a presently preferred embodiment, the DSP module 10-3 receives the wideband digitized data stream (Figure 2E, step S1), and uses the first DSP (10-3-1A and 10-3-1B) to extract blocks of channels (step S2). For example, a first DSP programmed to  
30 operate as a digital drop receiver can extract four blocks of channels, where each block includes at least 1.25 MHz of bandwidth. This bandwidth can include 42 channels of AMPS or TDMA, 6 channels of GSM, or 1 channel of CDMA. The DSP does not require



the blocks to be contiguous, as the DSP can independently digitally tune to any set of RF channels within the bandwidth of the wideband digitized data stream. The DSP can also perform wideband or narrow band energy detection on all or any of the channels in the block, and report the power levels by channel to the TLP 12 (step S3). For example, every 5 10 ms, the DSP can perform wideband energy detection and create an RF spectral map for all channels for all receivers (see step S9). Because this spectral map can be sent from the SCS 10 to the TLP 12 every 10 ms via the communications link connecting the SCS 10 and the TLP 12, a significant data overhead could exist. Therefore, the DSP reduces the data overhead by companding the data into a finite number of levels. Normally, for 10 example, 84 dB of dynamic range could require 14 bits. In the companding process implemented by the DSP, the data is reduced, for example, to only 4 bits by selecting 16 important RF spectral levels to send to the TLP 12. The choice of the number of levels, and therefore the number of bits, as well as the representation of the levels, can be automatically adjusted by the Wireless Location System. These adjustments are performed 15 to maximize the information value of the RF spectral messages sent to the TLP 12 as well as to optimize the use of the bandwidth available on the communications link between the SCS 10 and the TLP 12.

After conversion, each block of RF channels (each at least 1.25 MHz) is passed through 20 serial to parallel converter 10-3-2 and then stored in dual port digital memory 10-3-3 (step S4). The digital memory is a circular memory, which means that the DSP module begins writing data into the first memory address and then continues sequentially until the last memory address is reached. When the last memory address is reached, the DSP returns to the first memory address and continues to sequentially write data into memory. Each DSP 25 module typically contains enough memory to store several seconds of data for each block of RF channels to support the latency and queuing times in the location process.

In the DSP module, the memory address at which digitized and converted RF data is written into memory is the time stamp used throughout the Wireless Location System and 30 which the location processing references in determining TDOA. In order to ensure that the time stamps are aligned at every SCS 10 in the Wireless Location System, the address generator 10-3-8 receives the one pulse per second signal from the timing generation/clock

distribution module 10-7 (Figure 2). Periodically, the address generator at all SCS's 10 in a Wireless Location System will simultaneously reset themselves to a known address. This enables the location processing to reduce or eliminate accumulated timing errors in the recording of time stamps for each digitized data element.

5

The address generator 10-3-8 controls both writing to and reading from the dual port digital memory 10-3-3. Writing takes place continuously since the ADC is continuously sampling and digitizing RF signals and the first DSP (10-3-1A and 10-3-1B) is continuously performing the digital drop receiver function. However, reading occurs in bursts as the Wireless Location System requests data for performing demodulation and location processing. The Wireless Location System may even perform location processing recursively on a single transmission, and therefore requires access to the same data multiple times. In order to service the many requirements of the Wireless Location System, the address generator allows the dual port digital memory to be read at a rate faster than the writing occurs. Typically, reading can be performed eight times faster than writing.

The DSP module 10-3 uses the second DSP 10-3-4 to read the data from the digital memory 10-3-3, and then performs a second digital drop receiver function to extract baseband data from the blocks of RF channels (step S5). For example, the second DSP can extract any single 30 KHz AMPS or TDMA channel from any block of RF channels that have been digitized and stored in the memory. Likewise, the second DSP can extract any single GSM channel. The second DSP is not required to extract a CDMA channel, since the channel bandwidth occupies the full bandwidth of the stored RF data. The combination of the first DSP 10-3-1A, 10-3-1B and the second DSP 10-3-4 allows the DSP module to select, store, and recover any single RF channel in a wireless communications system. A DSP module typically will store four blocks of channels. In a dual-mode AMPS/TDMA system, a single DSP module can continuously and simultaneously monitor up to 42 analog reverse control channels, up to 84 digital control channels, and also be tasked to monitor and locate any voice channel transmission. A single SCS chassis will typically support up to three receiver modules 10-2 (Figure 2), to cover three sectors of two antennas each, and up to nine DSP modules (three DSP modules per receiver permits an

entire 15 MHz bandwidth to be simultaneously stored into digital memory). Thus, the SCS 10 is a very modular system than can be easily scaled to match any type of cell site configuration and processing load.

- 5 The DSP module 10-3 also performs other functions, including automatic detection of active channels used in each sector (step S6), demodulation (step S7), and station based location processing (step S8). The Wireless Location System maintains an active map of the usage of the RF channels in a wireless communications system (step S9), which enables the Wireless Location System to manage receiver and processing resources, and to
- 10 rapidly initiate processing when a particular transmission of interest has occurred. The active map comprises a table maintained within the Wireless Location System that lists for each antenna connected to an SCS 10 the primary channels assigned to that SCS 10 and the protocols used in those channels. A primary channel is an RF control channel assigned to a collocated or nearby base station which the base station uses for communications with
- 15 wireless transmitters. For example, in a typical cellular system with sectored cell sites, there will be one RF control channel frequency assigned for use in each sector. Those control channel frequencies would typically be assigned as primary channels for a collocated SCS 10.
- 20 The same SCS 10 may also be assigned to monitor the RF control channels of other nearby base stations as primary channels, even if other SCS's 10 also have the same primary channels assigned. In this manner, the Wireless Location System implements a system demodulation redundancy that ensures that any given wireless transmission has an infinitesimal probability of being missed. When this demodulation redundancy feature is
- 25 used, the Wireless Location System will receive, detect, and demodulate the same wireless transmission two or more times at more than one SCS 10. The Wireless Location System includes means to detect when this multiple demodulation has occurred and to trigger location processing only once. This function conserves the processing and communications resources of the Wireless Location System, and is further described
- 30 below. This ability for a single SCS 10 to detect and demodulate wireless transmissions occurring at cell sites not collocated with the SCS 10 permits operators of the Wireless Location System to deploy more efficient Wireless Location System networks. For

example, the Wireless Location System may be designed such that the Wireless Location System uses much fewer SCS's 10 than the wireless communications system has base stations.

- 5 In the Wireless Location System, primary channels are entered and maintained in the table using two methods: direct programming and automatic detection. Direct programming comprises entering primary channel data into the table using one of the Wireless Location System user interfaces, such as the Network Operations Console 16 (Figure 1), or by receiving channel assignment data from the Wireless Location System to wireless  
10 communications system interface. Alternatively, the DSP module 10-3 also runs a background process known as automatic detection in which the DSP uses spare or scheduled processing capacity to detect transmissions on various possible RF channels and then attempt to demodulate those transmissions using probable protocols. The DSP module can then confirm that the primary channels directly programmed are correct, and  
15 can also quickly detect changes made to channels at base station and send an alert to the operator of the Wireless Location System.

The DSP module performs the following steps in automatic detection (see Figure 2E-1):

- 20 for each possible control and/or voice channel which may be used in the coverage area of the SCS 10, peg counters are established (step S7-1);  
at the start of a detection period, all peg counters are reset to zero (step S7-2);  
each time that a transmission occurs in a specified RF channel, and the received power level is above a particular pre-set threshold, the peg counter for that channel is incremented (step S7-3);  
25 each time that a transmission occurs in a specified RF channel, and the received power level is above a second particular pre-set threshold, the DSP module attempts to demodulate a certain portion of the transmission using a first preferred protocol (step S7-4);  
if the demodulation is successful, a second peg counter for that channel is incremented  
30 (step S7-5);  
if the demodulation is unsuccessful, the DSP module attempts to demodulate a portion of the transmission using a second preferred protocol (step S7-6);

if the demodulation is successful, a third peg counter for that channel is incremented (step S7-7);  
at the end of a detection period, the Wireless Location System reads all peg counters (step S7-8); and  
5 the Wireless Location System automatically assigns primary channels based upon the peg counters (step S7-9).

The operator of the Wireless Location System can review the peg counters and the automatic assignment of primary channels and demodulation protocols, and override any  
10 settings that were performed automatically. In addition, if more than two preferred protocols may be used by the wireless carrier, then the DSP module 10-3 can be downloaded with software to detect the additional protocols. The architecture of the SCS 10, based upon wideband receivers 10-2, DSP modules 10-3, and downloadable software permits the Wireless Location System to support multiple demodulation protocols in a  
15 single system. There is a significant cost advantage to supporting multiple protocols within the single system, as only a single SCS 10 is required at a cell site. This is in contrast to many base station architectures, which may require different transceiver modules for different modulation protocols. For example, while the SCS 10 could support AMPS, TDMA, and CDMA simultaneously in the same SCS 10, there is no base station currently  
20 available that can support this functionality.

The ability to detect and demodulate multiple protocols also includes the ability to independently detect the use of authentication in messages transmitted over the certain air interface protocols. The use of authentication fields in wireless transmitters started to  
25 become prevalent within the last few years as a means to reduce the occurrence of fraud in wireless communications systems. However, not all wireless transmitters have implemented authentication. When authentication is used, the protocol generally inserts an additional field into the transmitted message. Frequently this field is inserted between the identity of the wireless transmitter and the dialed digits in the transmitted message. When  
30 demodulating a wireless transmission, the Wireless Location System determines the number of fields in the transmitted message, as well as the message type (i.e. registration, origination, page response, etc.). The Wireless Location System demodulates all fields and

if extra fields appear to be present, giving consideration to the type of message transmitted, then the Wireless Location System tests all fields for a trigger condition. For example, if the dialed digits "911" appear in the proper place in a field, and the field is located either in its proper place without authentication or its proper place with authentication, then the Wireless Location System triggers normally. In this example, the digits "911" would be required to appear in sequence as "911" or "\*911", with no other digits before or after either sequence. This functionality reduces or eliminates a false trigger caused by the digits "911" appearing as part of an authentication field.

10 The support for multiple demodulation protocols is important for the Wireless Location System to successfully operate because location processing must be quickly triggered when a wireless caller has dialed "911". The Wireless Location System can trigger location processing using two methods: the Wireless Location System will independently demodulate control channel transmissions, and trigger location processing using any number of criteria such as dialed digits, or the Wireless Location System may receive triggers from an external source such as the carrier's wireless communications system. The present inventors have found that independent demodulation by the SCS 10 results in the fastest time to trigger, as measured from the moment that a wireless user presses the "SEND" or "TALK" (or similar) button on a wireless transmitter.

20

#### Control and Communications Module 10-5

The control and communications module 10-5, depicted in Figure 2F, includes data buffers 10-5-1, a controller 10-5-2, memory 10-5-3, a CPU 10-5-4 and a T1/E1 communications chip 10-5-5. The module has many of the characteristics previously described in Patent Number 5,608,410. Several enhancements have been added in the present embodiment. For example, the SCS 10 now includes an automatic remote reset capability, even if the CPU on the control and communications module ceases to execute its programmed software. This capability can reduce the operating costs of the Wireless Location System because technicians are not required to travel to a cell site to reset an SCS 10 if it fails to operate normally. The automatic remote reset circuit operates by monitoring the communications interface between the SCS 10 and the TLP 12 for a particular sequence of bits. This sequence of bits is a sequence that does not occur during

normal communications between the SCS 10 and the TLP 12. This sequence, for example, may consist of an all ones pattern. The reset circuit operates independently of the CPU so that even if the CPU has placed itself in a locked or other non-operating status, the circuit can still achieve the reset of the SCS 10 and return the CPU to an operating status.

5

This module now also has the ability to record and report a wide variety of statistics and variables used in monitoring or diagnosing the performance of the SCS 10. For example, the SCS 10 can monitor the percent capacity usage of any DSP or other processor in the SCS 10, as well as the communications interface between the SCS 10 and the TLP 12.

10 These values are reported regularly to the AP 14 and the NOC 16, and are used to determine when additional processing and communications resources are required in the system. For example, alarm thresholds may be set in the NOC to indicate to an operator if any resource is consistently exceeding a preset threshold. The SCS 10 can also monitor the number of times that transmissions have been successfully demodulated, as well as the  
15 number of failures. This is useful in allowing operators to determine whether the signal thresholds for demodulation have been set optimally.

This module, as well as the other modules, can also self-report its identity to the TLP 12. As described below, many SCS's 10 can be connected to a single TLP 12. Typically, the  
20 communications between SCS's 10 and TLP's 12 is shared with the communications between base stations and MSC's. It is frequently difficult to quickly determine exactly which SCS's 10 have been assigned to particular circuits. Therefore, the SCS 10 contains a hard coded identity, which is recorded at the time of installation. This identity can be read and verified by the TLP 12 to positively determine which SCS 10 has been assigned  
25 by a carrier to each of several different communications circuits.

The SCS to TLP communications supports a variety of messages, including: commands and responses, software download, status and heartbeat, parameter download, diagnostic, spectral data, phase data, primary channel demodulation, and RF data. The  
30 communications protocol is designed to optimize Wireless Location System operation by minimizing the protocol overhead and the protocol includes a message priority scheme. Each message type is assigned a priority, and the SCS 10 and the TLP 12 will queue

messages by priority such that a higher priority message is sent before a lower priority message is sent. For example, demodulation messages are generally set at a high priority because the Wireless Location System must trigger location processing on certain types of calls (i.e., E9-1-1) without delay. Although higher priority messages are queued before  
5 lower priority messages, the protocol generally does not preempt a message that is already in transit. That is, a message in the process of being sent across the SCS 10 to TLP 12 communications interface will be completed fully, but then the next message to be sent will be the highest priority message with the earliest time stamp. In order to minimize the latency of high priority messages, long messages, such as RF data, are sent in segments.  
10 For example, the RF data for a full 100-millisecond AMPS transmission may be separated into 10-millisecond segments. In this manner, a high priority message may be queued in between segments of the RF data.

#### Calibration and Performance Monitoring

15 The architecture of the SCS 10 is heavily based upon digital technologies including the digital receiver and the digital signal processors. Once RF signals have been digitized, timing, frequency, and phase differences can be carefully controlled in the various processes. More importantly, any timing, frequency, and phase differences can be perfectly matched between the various receivers and various SCS's 10 used in the  
20 Wireless Location System. However, prior to the ADC, the RF signals pass through a number of RF components, including antennas, cables, low noise amplifiers, filters, duplexors, multi-couplers, and RF splitters. Each of these RF components has characteristics important to the Wireless Location System, including delay and phase versus frequency response. When the RF and analog components are perfectly matched  
25 between the pairs of SCS's 10, such as SCS 10A and SCS 10B in Figure 2G, then the effects of these characteristics are automatically eliminated in the location processing. But when the characteristics of the components are not matched, then the location processing can inadvertently include instrumental errors resulting from the mismatch. Additionally,  
30 many of these RF components can experience instability with power, time, temperature, or other factors that can add instrumental errors to the determination of location. Therefore, several inventive techniques have been developed to calibrate the RF components in the Wireless Location System and to monitor the performance of the Wireless Location



System on a regular basis. Subsequent to calibration, the Wireless Location System stores the values of these delays and phases versus frequency response (i.e. by RF channel number) in a table in the Wireless Location System for use in correcting these instrumental errors. Figures 2G-2J are referred to below in explaining these calibration methods.

#### External Calibration Method

Referring to Figure 2G, the timing stability of the Wireless Location System is measured along baselines, where each baseline is comprised of two SCS's, 10A and 10B, and an imaginary line (A - B) drawn between them. In a TDOA / FDOA type of Wireless Location System, locations of wireless transmitters are calculated by measuring the differences in the times that each SCS 10 records for the arrival of the signal from a wireless transmitter. Thus, it is important that the differences in times measured by SCS's 10 along any baseline are largely attributed to the transmission time of the signal from the wireless transmitter and minimally attributed to the variations in the RF and analog components of the SCS's 10 themselves. To meet the accuracy goals of the Wireless Location System, the timing stability for any pair of SCS's 10 are maintained at much less than 100 nanoseconds RMS (root mean square). Thus, the components of the Wireless Location System will contribute less than 100 feet RMS of instrumentation error in the estimation of the location of a wireless transmitter. Some of this error is allocated to the ambiguity of the signal used to calibrate the system. This ambiguity can be determined from the well-known Cramer-Rao lower bound equation. In the case of an AMPS reverse control channel, this error is approximately 40 nanoseconds RMS. The remainder of the error budget is allocated to the components of the Wireless Location System, primarily the RF and analog components in the SCS 10.

In the external calibration method, the Wireless Location System uses a network of calibration transmitters whose signal characteristics match those of the target wireless transmitters. These calibration transmitters may be ordinary wireless telephones emitting periodic registration signals and/or page response signals. Each usable SCS-to-SCS baseline is preferably calibrated periodically using a calibration transmitter that has a relatively clear and unobstructed path to both SCS's 10 associated with the baseline. The

calibration signal is processed identically to a signal from a target wireless transmitter. Since the TDOA values are known *a priori*, any errors in the calculations are due to systemic errors in the Wireless Location System. These systemic errors can then be removed in the subsequent location calculations for target transmitters.

5

Figure 2G illustrates the external calibration method for minimizing timing errors. As shown, a first SCS 10A at a point "A" and a second SCS 10A at a point "B" have an associated baseline A-B. A calibration signal emitted at time  $T_0$  by a calibration transmitter at point "C" will theoretically reach first SCS 10A at time  $T_0 + T_{AC}$ .  $T_{AC}$  is a measure of the amount of time required for the calibration signal to travel from the antenna on the calibration transmitter to the dual port digital memory in a digital receiver. Likewise, the same calibration signal will reach second SCS 10B at a theoretical time  $T_0 + T_{BC}$ . Usually, however, the calibration signal will not reach the digital memory and the digital signal processing components of the respective SCS's 10 at exactly the correct times. Rather, there will be errors  $e_1$  and  $e_2$  in the amount of time ( $T_{AC}$ ,  $T_{BC}$ ) it takes the calibration signal to propagate from the calibration transmitter to the SCS's 10, respectively, such that the exact times of arrival are actually  $T_0 + T_{AC} + e_1$  and  $T_0 + T_{BC} + e_2$ . Such errors will be due to some extent to delays in the signal propagation through the air, i.e., from the calibration transmitter's antenna to the SCS antennas; however, the errors will be due primarily to time varying characteristics in the SCS front end components. The errors  $e_1$  and  $e_2$  cannot be determined *per se* because the system does not know the exact time ( $T_0$ ) at which the calibration signal was transmitted. The system can, however, determine the error in the *difference* in the time of arrival of the calibration signal at the respective SCS's 10 of any given pair of SCS's 10. This TDOA error value is defined as the difference between the measured TDOA value and the theoretical TDOA value  $\tau_0$ , where  $\tau_0$  is the theoretical differences between the theoretical delay values  $T_{AC}$  and  $T_{BC}$ . Theoretical TDOA values for each pair of SCS's 10 and each calibration transmitter are known because the positions of the SCS's 10 and calibration transmitter, and the speed at which the calibration signal propagates, are known. The measured TDOA baseline ( $TDOA_{A-B}$ ) can be represented as  $TDOA_{A-B} = \tau_0 + \epsilon$ , where  $\epsilon = e_1 - e_2$ . In a similar manner, a calibration signal from a second calibration transmitter at point "D" will have associated errors  $e_3$  and  $e_4$ . The ultimate value of  $\epsilon$  to be subtracted from TDOA

measurements for a target transmitter will be a function (e.g., weighted average) of the  $\epsilon$  values derived for one or more calibration transmitters. Therefore, a given TDOA measurement ( $TDOA_{\text{measured}}$ ) for a pair of SCS's 10 at points "X" and "Y" and a target wireless transmitter at an unknown location will be corrected as follows:

5

$$\begin{aligned} TDOA_{X-Y} &= TDOA_{\text{measured}} - \epsilon \\ \epsilon &= k_1\epsilon_1 + k_2\epsilon_2 + \dots + k_N\epsilon_N, \end{aligned}$$

where  $k_1, k_2$ , etc., are weighting factors and  $\epsilon_1, \epsilon_2$ , etc., are the errors determined by subtracting the measured TDOA values from the theoretical values for each calibration transmitter. In this example, error value  $\epsilon_1$  may be the error value associated with the calibration transmitter at point "C" in the drawing. The weighting factors are determined by the operator of the Wireless Location System, and input into the configuration tables for each baseline. The operator will take into consideration the distance from each calibration transmitter to the SCS's 10 at points "X" and "Y", the empirically determined line of sight from each calibration transmitter to the SCS's 10 at points "X" and "Y", and the contribution that each SCS "X" and "Y" would have made to a location estimate of a wireless transmitter that might be located in the vicinity of each calibration transmitter. In general, calibration transmitters that are nearer to the SCS's 10 at points "X" and "Y" will be weighted higher than calibration transmitters that are farther away, and calibration transmitters with better line of sight to the SCS's 10 at points "X" and "Y" will be weighted higher than calibration transmitters with worse line of sight.

Each error component  $\epsilon_1, \epsilon_2$ , etc., and therefore the resulting error component  $\epsilon$ , can vary widely, and wildly, over time because some of the error component is due to multipath reflection from the calibration transmitter to each SCS 10. The multipath reflection is very much path dependent and therefore will vary from measurement to measurement and from path to path. It is not an object of this method to determine the multipath reflection for these calibration paths, but rather to determine the portion of the errors that are attributable to the components of the SCS's 10. Typically, therefore, error values  $\epsilon_1$  and  $\epsilon_3$  will have a common component since they relate to the same first SCS 10A. Likewise, error values  $\epsilon_2$

and e4 will also have a common component since they relate to the second SCS 10B. It is known that while the multipath components can vary wildly, the component errors vary slowly and typically vary sinusoidally. Therefore, in the external calibration method, the error values  $\epsilon$  are filtered using a weighted, time-based filter that decreases the weight of the wildly varying multipath components while preserving the relatively slow changing error components attributed to the SCS's 10. One such exemplary filter used in the external calibration method is the Kalman filter.

The period between calibration transmissions is varied depending on the error drift rates determined for the SCS components. The period of the drift rate should be much longer than the period of the calibration interval. The Wireless Location System monitors the period of the drift rate to determine continuously the rate of change, and may periodically adjust the calibration interval, if needed. Typically, the calibration rate for a Wireless Location System such as one in accordance with the present invention is between 10 and 30 minutes. This corresponds well with the typical time period for the registration rate in a wireless communications system. If the Wireless Location System were to determine that the calibration interval must be adjusted to a rate faster than the registration rate of the wireless communications system, then the AP 14 (Figure 1) would automatically force the calibration transmitter to transmit by paging the transmitter at the prescribed interval. Each calibration transmitter is individually addressable and therefore the calibration interval associated with each calibration transmitter can be different.

Since the calibration transmitters used in the external calibration method are standard telephones, the Wireless Location System must have a mechanism to distinguish those telephones from the other wireless transmitters that are being located for various application purposes. The Wireless Location System maintains a list of the identities of the calibration transmitters, typically in the TLP 12 and in the AP 14. In a cellular system, the identity of the calibration transmitter can be the Mobile Identity Number, or MIN. When the calibration transmitter makes a transmission, the transmission is received by each SCS 10 and demodulated by the appropriate SCS 10. The Wireless Location System compares the identity of the transmission with a pre-stored tasking list of identities of all calibration transmitters. If the Wireless Location System determines that the transmission was a

calibration transmission, then the Wireless Location System initiates external calibration processing.

#### Internal Calibration Method

5 In addition to the external calibration method, it is an object of the present invention to calibrate all channels of the wideband digital receiver used in the SCS 10 of a Wireless Location System. The external calibration method will typically calibrate only a single channel of the multiple channels used by the wideband digital receiver. This is because the fixed calibration transmitters will typically scan to the highest-power control channel,  
10 which will typically be the same control channel each time. The transfer function of a wideband digital receiver, along with the other associated components, does not remain perfectly constant, however, and will vary with time and temperature. Therefore, even though the external calibration method can successfully calibrate a single channel, there is no assurance that the remaining channels will also be calibrated.

15

The internal calibration method, represented in the flowchart of Figure 2H, is particularly suited for calibrating an individual first receiver system (i.e., SCS 10) that is characterized by a time- and frequency-varying transfer function, wherein the transfer function defines how the amplitude and phase of a received signal will be altered by the receiver system  
20 and the receiver system is utilized in a location system to determine the location of a wireless transmitter by, in part, determining a difference in time of arrival of a signal transmitted by the wireless transmitter and received by the receiver system to be calibrated and another receiver system, and wherein the accuracy of the location estimate is dependent, in part, upon the accuracy of TDOA measurements made by the system. An  
25 example of a AMPS RCC transfer function is depicted in Figure 2I, which depicts how the phase of the transfer function varies across the 21 control channels spanning 630 KHz.

Referring to Figure 2H, the internal calibration method includes the steps of temporarily and electronically disconnecting the antenna used by a receiver system from the receiver  
30 system (step S-20); injecting an internally generated wideband signal with known and stable signal characteristics into the first receiver system (step S-21); utilizing the generated wideband signal to obtain an estimate of the manner in which the transfer

function varies across the bandwidth of the first receiver system (step S-22); and utilizing the estimate to mitigate the effects of the variation of the first transfer function on the time and frequency measurements made by the first receiver system (step S-23). One example of a stable wideband signal used for internal calibration is a comb signal, which is  
5 comprised of multiple individual, equal-amplitude frequency elements at a known spacing, such as 5 KHz. An example of such a signal is shown in Figure 2I.

The antenna must be temporarily disconnected during the internal calibration process to prevent external signals from entering the wideband receiver and to guarantee that the  
10 receiver is only receiving the stable wideband signal. The antenna is electronically disconnected only for a few milliseconds to minimize the chance of missing too much of a signal from a wireless transmitter. In addition, internal calibration is typically performed immediately after external calibration to minimize the possibility that the any component in the SCS 10 drifts during the interval between external and internal calibration. The  
15 antenna is disconnected from the wideband receiver using two electronically controlled RF relays (not shown). An RF relay cannot provide perfect isolation between input and output even when in the "off" position, but it can provide up to 70 dB of isolation. Two relays may be used in series to increase the amount of isolation and to further assure that no signal is leaked from the antenna to the wideband receiver during calibration. Similarly,  
20 when the internal calibration function is not being used, the internal calibration signal is turned off, and the two RF relays are also turned off to prevent leakage of the internal calibration signals into the wideband receiver when the receiver is collecting signals from wireless transmitters.

25 The external calibration method provides an absolute calibration of a single channel and the internal calibration method then calibrates each other channel relative to the channel that had been absolutely calibrated. The comb signal is particularly suited as a stable wideband signal because it can be easily generated using a stored replica of the signal and a digital to analog converter.

30

#### External Calibration Using Wideband Calibration Signal

The external calibration method described next may be used in connection with an SCS receiver system characterized by a time- and frequency-varying transfer function, which preferably includes the antennas, filters, amplifiers, duplexors, multi-couplers, splitters, and cabling associated with the SCS receiver system. The method includes the step of transmitting a stable, known wideband calibration signal from an external transmitter. The wideband calibration signal is then used to estimate the transfer function across a prescribed bandwidth of the SCS receiver system. The estimate of the transfer function is subsequently employed to mitigate the effects of variation of the transfer function on subsequent TDOA/FDOA measurements. The external transmission is preferably of short duration and low power to avoid interference with the wireless communications system hosting the Wireless Location System.

In the preferred method, the SCS receiver system is synchronized with the external transmitter. Such synchronization may be performed using GPS timing units. Moreover, the receiver system may be programmed to receive and process the entire wideband of the calibration signal only at the time that the calibration signal is being sent. The receiver system will not perform calibration processing at any time other than when in synchronization with the external calibration transmissions. In addition, a wireless communications link is used between the receiver system and the external calibration transmitter to exchange commands and responses. The external transmitter may use a directional antenna to direct the wideband signal only at the antennas of the SCS receiver system. Such as directional antenna may be a Yagi antenna (i.e. linear end-fire array). The calibration method preferably includes making the external transmission only when the directional antenna is aimed at the receiver system's antennas and the risk of multipath reflection is low.

#### Calibrating for Station Biases

Another aspect of the present invention concerns a calibration method to correct for station biases in a SCS receiver system. The "station bias" is defined as the finite delay between when an RF signal from a wireless transmitter reaches the antenna and when that same signal reached the wideband receiver. The inventive method includes the step of

measuring the length of the cable from the antennas to the filters and determining the corresponding delays associated with the cable length. In addition, the method includes injecting a known signal into the filter, duplexer, multi-coupler, or RF splitter and measuring the delay and phase response versus frequency response from the input of each device to the wideband receiver. The delay and phase values are then combined and used to correct subsequent location measurements. When used with the GPS based timing generation described above, the method preferably includes correcting for the GPS cable lengths. Moreover, an externally generated reference signal is preferably used to monitor changes in station bias that may arise due to aging and weather. Finally, the station bias by RF channel and for each receiver system in the Wireless Location System is preferably stored in tabular form in the Wireless Location System for use in correcting subsequent location processing.

#### Performance Monitoring

The Wireless Location System uses methods similar to calibration for performance monitoring on a regular and ongoing basis. These methods are depicted in the flowcharts of Figure 2K and 2L. Two methods of performance monitoring are used: fixed phones and drive testing of surveyed points. The fixed phone method comprises the following steps (see Figure 2K):

- standard wireless transmitters are permanently placed at various points within the coverage area of the Wireless Location System (these are then known as the fixed phones) (step S-30);
- the points at which the fixed phones have been placed are surveyed so that their location is precisely known to within a predetermined distance, for example ten feet (step S-31);
- the surveyed locations are stored in a table in the AP 14 (step S-32);
- the fixed phones are permitted to register on the wireless communications system, at the rate and interval set by the wireless communications system for all wireless transmitters on the system (step S-33);
- at each registration transmission by a fixed phone, the Wireless Location System locates the fixed phone using normal location processing (as with the calibration



transmitters, the Wireless Location System can identify a transmission as being from a fixed phone by storing the identities in a table) (step S-34);  
the Wireless Location System computes an error between the calculated location determined by the location processing and the stored location determined by survey  
5 (step S-35);  
the location, the error value, and other measured parameters are stored along with a time stamp in a database in the AP 14 (step S-36);  
the AP 14 monitors the instant error and other measured parameters (collectively referred to as an extended location record) and additionally computes various  
10 statistical values of the error(s) and other measured parameters (step S-37); and  
if any of the error or other values exceed a pre-determined threshold or a historical statistical value, either instantaneously or after performing statistical filtering over a prescribed number of location estimates, the AP 14 signals an alarm to the operator of the Wireless Location System (step S-38).

15  
The extended location record includes a large number of measured parameters usefully for analyzing the instant and historical performance of the Wireless Location System. These parameters include: the RF channel used by the wireless transmitter, the antenna port(s) used by the Wireless Location System to demodulate the wireless transmission, the  
20 antenna ports from which the Wireless Location System requested RF data, the peak, average, and variance in power of the transmission over the interval used for location processing, the SCS 10 and antenna port chosen as the reference for location processing, the correlation value from the cross-spectra correlation between every other SCS 10 and antenna used in location processing and the reference SCS 10 and antenna, the delay value  
25 for each baseline, the multipath mitigation parameters, and the residual values remaining after the multipath mitigation calculations. Any of these measured parameters can be monitored by the Wireless Location System for the purpose of determining how the Wireless Location System is performing. One example of the type of monitoring performed by the Wireless Location System may be the variance between the instant value  
30 of the correlation on a baseline and the historical range of the correlation value. Another may be the variance between the instant value of the received power at a particular

antenna and the historical range of the received power. Many other statistical values can be calculated and this list is not exhaustive.

- 5 The number of fixed phones placed into the coverage area of the Wireless Location System can be determined based upon the density of the cell sites, the difficulty of the terrain, and the historical ease with which wireless communications systems have performed in the area. Typically the ratio is about one fixed phone for every six cell sites, however in some areas a ratio of one to one may be required. The fixed phones provide a continuous means to monitor the performance of the Wireless Location System, as well as
- 10 the monitor any changes in the frequency plan that the carrier may have made. Many times, changes in the frequency plan will cause a variation in the performance of the Wireless Location System and the performance monitoring of the fixed phones provide an immediate indication to the Wireless Location System operator.
- 15 Drive testing of surveyed points is very similar to the fixed phone monitoring. Fixed phones typically can only be located indoors where access to power is available (i.e. the phones must be continuously powered on to be effective). To obtain a more complete measurement of the performance of the location performance, drive testing of outdoor test points is also performed. Referring to Figure 2L, as with the fixed phones, prescribed test
- 20 points throughout the coverage area of the Wireless Location System are surveyed to within ten feet (step S-40). Each test point is assigned a code, where the code consists of either a "\*" or a "#", followed by a sequence number (step S-41). For example, "\*1001" through "\*1099" may be a sequence of 99 codes used for test points. These codes should be sequences, that when dialed, are meaningless to the wireless communications system
- 25 (i.e. the codes do not cause a feature or other translation to occur in the MSC, except for an intercept message). The AP 14 stores the code for each test point along with the surveyed location (step S-42). Subsequent to these initial steps, any wireless transmitter dialing any of the codes will be triggered and located using normal location processing (steps S-43 and S-44). The Wireless Location System automatically computes an error
- 30 between the calculated location determined by the location processing and the stored location determined by survey, and the location and the error value are stored along with a time stamp in a database in the AP 14 (steps S-45 and S-46). The AP 14 monitors the

instant error, as well as various historical statistical values of the error. If the error values exceed a pre-determined threshold or a historical statistical value, either instantaneously or after performing statistical filtering over a prescribed number of location estimates, the AP 14 signals an alarm to the operator of the Wireless Location System (step S-47).

5

#### TDOA Location Processor (TLP)

The TLP 12, depicted in Figures 1, 1A and 3, is a centralized digital signal processing system that manages many aspects of the Wireless Location System, especially the SCS's 10, and provides control over the location processing. Because location processing is DSP  
10 intensive, one of the major advantages of the TLP 12 is that the DSP resources can be shared among location processing initiated by transmissions at any of the SCS's 10 in a Wireless Location System. That is, the additional cost of DSP's at the SCS's 10 is reduced by having the resource centrally available. As shown in Figure 3, there are three major components of the TLP 12: DSP modules 12-1, T1/E1 communications modules 12-2 and  
15 a controller module 12-3.

The T1/E1 communications modules 12-2 provide the communications interface to the SCS's 10 (T1 and E1 are standard communications speeds available throughout the world). Each SCS 10 communicates to a TLP 12 using one or more DS0's (which are  
20 typically 56Kbps or 64 Kbps). Each SCS 10 typically connects to a fractional T1 or E1 circuit, using, e.g., a drop and insert unit or channel bank at the cell site. Frequently, this circuit is shared with the base station, which communicates with the MSC. At a central site, the DS0's assigned to the base station are separated from the DS0's assigned to the SCS's 10. This is typically accomplished external to the TLP 12 using a digital access and  
25 control system (DACS) 13A that not only separates the DS0's but also grooms the DS0's from multiple SCS's 10 onto full T1 or E1 circuits. These circuits then connect from the DACS 13A to the DACS 13B and then to the T1/E1 communications module on the TLP 12. Each T1/E1 communications module contains sufficient digital memory to buffer packets of data to and from each SCS 10 communicating with the module. A single TLP  
30 chassis may support one or more T1/E1 communications modules.

The DSP modules 12-1 provide a pooled resource for location processing. A single module may typically contain two to eight digital signal processors, each of which are equally available for location processing. Two types of location processing are supported: central based and station based, which are described in further detail below. The TLP controller 12-3 manages the DSP module(s) 12-1 to obtain optimal throughput. Each DSP module contains sufficient digital memory to store all of the data necessary for location processing. A DSP is not engaged until all of the data necessary to begin location processing has been moved from each of the involved SCS's 10 to the digital memory on the DSP module. Only then is a DSP given the specific task to locate a specific wireless transmitter. Using this technique, the DSP's, which are an expensive resource, are never kept waiting. A single TLP chassis may support one or more DSP modules.

The controller module 12-3 provides the real time management of all location processing within the Wireless Location System. The AP 14 is the top-level management entity within the Wireless Location System, however its database architecture is not sufficiently fast to conduct the real time decision making when transmissions occur. The controller module 12-3 receives messages from the SCS's 10, including: status, spectral energy in various channels for various antennas, demodulated messages, and diagnostics. This enables the controller to continuously determine events occurring in the Wireless Location System, as well as to send commands to take certain actions. When a controller module receives demodulated messages from SCS's 10, the controller module decides whether location processing is required for a particular wireless transmission. The controller module 12-3 also determines which SCS's 10 and antennas to use in location processing, including whether to use central based or station based location processing. The controller module commands SCS's 10 to return the necessary data, and commands the communications modules and DSP modules to sequentially perform their necessary roles in location processing. These steps are described below in further detail.

The controller module 12-3 maintains a table known as the Signal of Interest Table (SOIT). This table contains all of the criteria that may be used to trigger location processing on a particular wireless transmission. The criteria may include, for example, the Mobile Identity Number, the Mobile Station ID, the Electronic Serial Number, dialed

digits, System ID, RF channel number, cell site number or sector number, type of transmission, and other types of data elements. Some of the trigger events may have higher or lower priority levels associated with them for use in determining the order of processing. Higher priority location triggers will always be processing before lower priority location triggers. However, a lower priority trigger that has already begun location processing will complete the processing before being assigned to a higher priority task. The master Tasking List for the Wireless Location System is maintained on the AP 14, and copies of the Tasking List are automatically downloaded to the Signal of Interest Table in each TLP 12 in the Wireless Location System. The full Signal of Interest Table is downloaded to a TLP 12 when the TLP 12 is reset or first starts. Subsequent to those two events, only changes are downloaded from the AP 14 to each TLP 12 to conserve communications bandwidth. The TLP 12 to AP 14 communications protocol preferably contains sufficient redundancy and error checking to prevent incorrect data from ever being entered into the Signal of Interest Table. When the AP 14 and TLP 12 periodically have spare processing capacity available, the AP 14 reconfirms entries in the Signal of Interest Table to ensure that all Signal of Interest Table entries in the Wireless Location System are in full synchronization.

Each TLP chassis has a maximum capacity associated with the chassis. For example, a single TLP chassis may only have sufficient capacity to support between 48 and 60 SCS's 10. When a wireless communications system is larger than the capacity of a single TLP chassis, multiple TLP chassis are connected together using Ethernet networking. The controller module 12-3 is responsible for inter-TLP communications and networking, and communicates with the controller modules in other TLP chassis and with Application Processors 14 over the Ethernet network. Inter-TLP communications is required when location processing requires the use of SCS's 10 that are connected to different TLP chassis. Location processing for each wireless transmission is assigned to a single DSP module in a single TLP chassis. The controller modules 12-3 in TLP chassis select the DSP module on which to perform location processing, and then route all of the RF data used in location processing to that DSP module. If RF data is required from the SCS's 10 connected to more than one TLP 12, then the controller modules in all necessary TLP chassis communicate to move the RF data from all necessary SCS's 10 to their respective

connected TLP's 12 and then to the DSP module and TLP chassis assigned to the location processing. The controller module supports two fully independent Ethernet networks for redundancy. A break or failure in any one network causes the affected TLP's 12 to immediately shift all communications to the other network.

5

The controller modules 12-3 maintain a complete network map of the Wireless Location System, including the SCS's 10 associated with each TLP chassis. The network map is a table stored in the controller module containing a list of the candidate SCS/antennas that may be used in location processing, and various parameters associated with each of the

10 SCS/antennas. The structure of an exemplary network map is depicted in Figure 3A. There is a separate entry in the table for each antenna connected to an SCS 10. When a wireless transmission occurs in an area that is covered by SCS's 10 communicating with more than one TLP chassis, the controller modules in the involved TLP chassis determine which TLP chassis will be the "master" TLP chassis for the purpose of managing location processing.

15 Typically, the TLP chassis associated with the SCS 10 that has the primary channel assignment for the wireless transmission is assigned to be the master. However, another TLP chassis may be assigned instead if that TLP temporarily has no DSP resources available for location processing, or if most of the SCS's 10 involved in location processing are connected to another TLP chassis and the controller modules are

20 minimizing inter-TLP communications. This decision making process is fully dynamic, but is assisted by tables in the TLP 12 that pre-determine the preferred TLP chassis for every primary channel assignment. The tables are created by the operator of the Wireless Location System, and programmed using the Network Operations Console.

25 The networking described herein functions for both TLP chassis associated with the same wireless carrier, as well as for chassis that overlap or border the coverage area between two wireless carriers. Thus it is possible for a TLP 12 belonging to a first wireless carrier to be networked and therefore receive RF data from a TLP 12 (and the SCS's 10 associated with that TLP 12) belonging to a second wireless carrier. This networking is

30 particularly valuable in rural areas, where the performance of the Wireless Location System can be enhanced by deploying SCS's 10 at cell sites of multiple wireless carriers. Since in many cases wireless carriers do not collocate cell sites, this feature enables the

Wireless Location System to access more geographically diverse antennas than might be available if the Wireless Location System used only the cell sites from a single wireless carrier. As described below, the proper selection and use of antennas for location processing can enhance the performance of the Wireless Location System.

5

The controller module 12-3 passes many messages, including location records, to the AP 14, many of which are described below. Usually, however, demodulated data is not passed from the TLP 12 to the AP 14. If, however, the TLP 12 receives demodulated data from a particular wireless transmitter and the TLP 12 identifies the wireless transmitter as being a registered customer of a second wireless carrier in a different coverage area, the TLP 12 may pass the demodulated data to the first (serving) AP 14A. This will enable the first AP 14A to communicate with a second AP 14B associated with the second wireless carrier, and determine whether the particular wireless transmitter has registered for any type of location services. If so, the second AP 14B may instruct the first AP 14A to place the identity of the particular wireless transmitter into the Signal of Interest Table so that the particular wireless transmitter will be located for as long as the particular wireless transmitter is in the coverage area of the first Wireless Location System associated with the first AP 14A. When the first Wireless Location System has detected that the particular wireless transmitter has not registered in a time period exceeding a pre-determined threshold, the first AP 14A may instruct the second AP 14B that the identity of the particular wireless transmitter is being removed from the Signal of Interest Table for the reason of no longer being present in the coverage area associated with the first AP 14A.

#### Diagnostic Port

The TLP 12 supports a diagnostic port that is highly useful in the operation and diagnosis of problems within the Wireless Location System. This diagnostic port can be accessed either locally at a TLP 12 or remotely over the Ethernet network connecting the TLP's 12 to the AP's. The diagnostic port enables an operator to write to a file all of the demodulation and RF data received from the SCS's 10, as well as the intermediate and final results of all location processing. This data is erased from the TLP 12 after processing a location estimate, and therefore the diagnostic port provides the means to save the data for later post-processing and analysis. The inventor's experience in operating

large scale wireless location systems is that a very small number of location estimates can occasionally have very large errors, and these large errors can dominate the overall operating statistics of the Wireless Location System over any measurement period. Therefore, it is important to provide the operator with a set of tools that enable the

5 Wireless Location System to detect and trap the cause of the very large errors to diagnose and mitigate those errors. The diagnostic port can be set to save the above information for all location estimates, for location estimates from particular wireless transmitters or at particular test points, or for location estimates that meet a certain criteria. For example, for fixed phones or drive testing of surveyed points, the diagnostic port can determine the

10 error in the location estimate in real time and then write the above described information only for those location estimates whose error exceeds a predetermined threshold. The diagnostic port determines the error in real time by storing the surveyed latitude, longitude coordinate of each fixed phone and drive test point in a table, and then calculating a radial error when a location estimate for the corresponding test point is made.

15

#### Redundancy

The TLP's 12 implement redundancy using several inventive techniques, allowing the Wireless Location System to support an M plus N redundancy method. M plus N redundancy means that N redundant (or standby) TLP chassis are used to provide full

20 redundant backup to M online TLP chassis. For example, M may be ten and N may be two.

First, the controller modules in different TLP chassis continuously exchange status and "heartbeat" messages at pre-determined time intervals between themselves and with every

25 AP 14 assigned to monitor the TLP chassis. Thus, every controller module has continuous and full status of every other controller module in the Wireless Location System. The controller modules in different TLP chassis periodically select one controller module in one TLP 12 to be the master controller for a group of TLP chassis. The master controller may decide to place a first TLP chassis into off-line status if the first TLP 12A reports a

30 failed or degraded condition in its status message, or if the first TLP 12A fails to report any status or heartbeat messages within its assigned and pre-determined time. If the master controller places a first TLP 12A into off-line status, the master controller may assign a



second TLP 12B to perform a redundant switchover and assume the tasks of the off-line first TLP 12A. The second TLP 12B is automatically sent the configuration that had been loaded into the first TLP 12A; this configuration may be downloaded from either the master controller or from an AP 14 connected to the TLP's 12. The master controller may  
5 be a controller module on any one of the TLP's 12 that is not in off-line status, however there is a preference that the master controller be a controller module in a stand-by TLP 12. When the master controller is the controller module in a stand-by TLP 12, the time required to detect a failed first TLP 12A, place the first TLP 12A into off-line status, and then perform a redundant switchover can be accelerated.

10

Second, all of the T1 or E1 communications between the SCS's 10 and each of the TLP T1/E1 communications modules 12-2 are preferably routed through a high-reliability DACS that is dedicated to redundancy control. The DACS 13B is connected to every groomed T1/E1 circuit containing DS0's from SCS's 10 and is also connected to every  
15 T1/E1 communications module 12-2 of every TLP 12. Every controller module at every TLP 12 contains a map of the DACS 13B that describes the DACS' connection list and port assignments. This DACS 13B is connected to the Ethernet network described above and can be controlled by any of the controller modules 12-3 at any of the TLP's 12. When a second TLP 12 is placed into off-line status by a master controller, the master controller  
20 sends commands to the DACS 13B to switch the groomed T1/E1 circuit communicating with the first TLP 12A to a second TLP 12B which had been in standby status. At the same time, the AP 14 downloads the complete configuration file that was being used by the second (and now off-line) TLP 12B to the third (and now online) TLP 12C. The time from the first detection of a failed first TLP chassis to the complete switch-over and  
25 assumption of processing responsibilities by a third TLP chassis is typically less than few seconds. In many cases, no RF data is lost by the SCS's 10 associated with the failed first TLP chassis, and location processing can continue without interruption. At the time of a TLP fail-over when a first TLP 12A is placed into off-line status, the NOC 16 creates an alert to notify the Wireless Location System operator that the event has occurred.

30

Third, each TLP chassis contains redundant power supplies, fans, and other components. A TLP chassis can also support multiple DSP modules, so that the failure of a single DSP

module or even a single DSP on a DSP module reduces the overall amount of processing resources available but does not cause the failure of the TLP chassis. In all of the cases described in this paragraph, the failed component of the TLP 12 can be replaced without placing the entire TLP chassis into off-line status. For example, if a single power supply fails, the redundant power supply has sufficient capacity to singly support the load of the chassis. The failed power supply contains the necessary circuitry to remove itself from the load of the chassis and not cause further degradation in the chassis. Similarly, a failed DSP module can also remove itself from the active portions of the chassis, so as to not cause a failure of the backplane or other modules. This enables the remainder of the chassis, including the second DSP module, to continue to function normally. Of course, the total processing throughput of the chassis is reduced but a total failure is avoided.

#### Application Processor (AP) 14

The AP 14 is a centralized database system, comprising a number of software processes that manage the entire Wireless Location System, provide interfaces to external users and applications, store location records and configurations, and support various application-related functionality. The AP 14 uses a commercial hardware platform that is sized to match the throughput of the Wireless Location System. The AP 14 also uses a commercial relational database system (RDBMS), which has been significantly customized to provide the functionality described herein. While the SCS 10 and TLP 12 preferably operate together on a purely real time basis to determine location and create location records, the AP 14 can operate on both a real time basis to store and forward location records and a non-real time basis to post-process location records and provide access and reporting over time. The ability to store, retrieve, and post-process location records for various types of system and application analysis has proven to be a powerful advantage of the present invention. The main collection of software processes is known as the ApCore, which is shown in Figure 4 and includes the following functions:

The AP Performance Guardian (ApPerfGuard) is a dedicated software process that is responsible for starting, stopping, and monitoring most other ApCore processes as well as ApCore communications with the NOC 16. Upon receiving a configuration update command from the NOC, ApPerfGuard updates the database and notifies all other

- processes of the change. ApPerfGuard starts and stops appropriate processes when the NOC directs the ApCore to enter specific run states, and constantly monitors other software processes scheduled to be running to restart them if they have exited or stopping and restarting any process that is no longer properly responding. ApPerfGuard is assigned to one of the highest processing priorities so that this process cannot be blocked by another process that has "run away". ApPerfGuard is also assigned dedicated memory that is not accessible by other software processes to prevent any possible corruption from other software processes.
- 10 The AP Dispatcher (ApMnDsptch) is a software process that receives location records from the TLP's 12 and forwards the location records to other processes. This process contains a separate thread for each physical TLP 12 configured in the system, and each thread receives location records from that TLP 12. For system reliability, the ApCore maintains a list containing the last location record sequence number received from each TLP 12, and sends this sequence number to the TLP 12 upon initial connection. Thereafter, the AP 14 and the TLP 12 maintain a protocol whereby the TLP 12 sends each location record with a unique identifier. ApMnDsptch forwards location records to multiple processes, including Ap911, ApDbSend, ApDbRecvLoc, and ApDbFileRecv.
- 20 The AP Tasking Process (ApDbSend) controls the Tasking List within the Wireless Location System. The Tasking List is the master list of all of the trigger criteria that determines which wireless transmitters will be located, which applications created the criteria, and which applications can receive location record information. The ApDbSend process contains a separate thread for each TLP 12, over which the ApDbSend synchronizes the Tasking List with the Signal of Interest Table on each TLP 12. ApDbSend does not send application information to the Signal of Interest Table, only the trigger criteria. Thus the TLP 12 does not know why a wireless transmitter must be located. The Tasking List allows wireless transmitters to be located based upon Mobile Identity Number (MIN), Mobile Station Identifier (MSID), Electronic Serial Number (ESN) and other identity numbers, dialed sequences of characters and / or digits, home System ID (SID), originating cell site and sector, originating RF channel, or message type. The Tasking List allows multiple applications to receive location records from the same

wireless transmitter. Thus, a single location record from a wireless transmitter that has dialed "911" can be sent, for example, to a 911 PSAP, a fleet management application, a traffic management application, and to an RF optimization application.

- 5 The Tasking List also contains a variety of flags and field for each trigger criteria, some of which are described elsewhere in this specification. One flag, for example, specifies the maximum time limit before which the Wireless Location System must provide a rough or final estimate of the wireless transmitter. Another flag allows location processing to be disabled for a particular trigger criteria such as the identity of the wireless transmitter.
- 10 Another field contains the authentication required to make changes to the criteria for a particular trigger; authentication enables the operator of the Wireless Location System to specify which applications are authorized to add, delete, or make changes to any trigger criteria and associated fields or flags. Another field contains the Location Grade of Service associated with the trigger criteria; Grade of Service indicates to the Wireless Location
- 15 System the accuracy level and priority level desired for the location processing associated with a particular trigger criteria. For example, some applications may be satisfied with a rough location estimate (perhaps for a reduced location processing fee), while other applications may be satisfied with low priority processing that is not guaranteed to complete for any given transmission (and which may be pre-empted for high priority
- 20 processing tasks). The Wireless Location System also includes means to support the use of wildcards for trigger criteria in the Tasking List. For example, a trigger criteria can be entered as "MIN = 21555\*\*\*\*". This will cause the Wireless Location System to trigger location processing for any wireless transmitter whose MIN begins with the six digits 215555 and ends with any following four digits. The wildcard characters can be placed
- 25 into any position in a trigger criteria. This feature can save on the number of memory locations required in the Tasking List and Signal of Interest Table by grouping blocks of related wireless transmitters together.

- ApDbSend also supports dynamic tasking. For example, the MIN, ESN, MSID, or other
- 30 identity of any wireless transmitter that has dialed "911" will automatically be placed onto the Tasking List by ApDbSend for one hour. Thus, any further transmissions by the wireless transmitter that dialed "911" will also be located in case of further emergency.

For example, if a PSAP calls back a wireless transmitter that had dialed "911" within the last hour, the Wireless Location System will trigger on the page response message from the wireless transmitter, and can make this new location record available to the PSAP. This dynamic tasking can be set for any interval of time after an initiation event, and for any type of trigger criteria. The ApDbSend process is also a server for receiving tasking requests from other applications. These applications, such as fleet management, can send tasking requests via a socket connection, for example. These applications can either place or remove trigger criteria. ApDbSend conducts an authentication process with each application to verify that that the application has been authorized to place or remove trigger criteria, and each application can only change trigger criteria related to that application.

The AP 911 Process (Ap911) manages each interface between the Wireless Location System and E9-1-1 network elements, such as tandem switches, selective routers, ALI databases and/or PSAPs. The Ap911 process contains a separate thread for each connection to a E9-1-1 network element, and can support more than one thread to each network element. The Ap911 process can simultaneously operate in many modes based upon user configuration, and as described herein. The timely processing of E9-1-1 location records is one of the highest processing priorities in the AP 14, and therefore the Ap911 executes entirely out of random access memory (RAM) to avoid the delay associated with first storing and then retrieving a location record from any type of disk. When ApMnDsptch forwards a location record to Ap911, Ap911 immediately makes a routing determination and forwards the location record over the appropriate interface to a E9-1-1 network element. A separate process, operating in parallel, records the location record into the AP 14 database.

The AP 14, through the Ap911 process and other processes, supports two modes of providing location records to applications, including E9-1-1: "push" and "pull" modes. Applications requesting push mode receive a location record as soon as it is available from the AP 14. This mode is especially effective for E9-1-1 which has a very time critical need for location records, since E9-1-1 networks must route wireless 9-1-1 calls to the correct PSAP within a few seconds after a wireless caller has dialed "911". Applications

requesting pull mode do not automatically receive location records, but rather must send a query to the AP 14 regarding a particular wireless transmitter in order to receive the last, or any other location record, about the wireless transmitter. The query from the application can specify the last location record, a series of location records, or all location records  
5 meeting a specific time or other criteria, such as type of transmission. An example of the use of pull mode in the case of a "911" call is the E9-1-1 network first receiving the voice portion of the "911" call and then querying the AP 14 to receive the location record associated with that call.

10 When the Ap911 process is connected to many E9-1-1 networks elements, Ap911 must determine to which E9-1-1 network element to push the location record (assuming that "push" mode has been selected). The AP 14 makes this determination using a dynamic routing table. The dynamic routing table is used to divide a geographic region into cells. Each cell, or entry, in the dynamic routing table contains the routing instructions for that  
15 cell. It is well known that one minute of latitude is 6083 feet, which is about 365 feet per millidegree. Additionally, one minute of longitude is  $\cos(\text{latitude})$  times 6083 feet, which for the Philadelphia area is about 4659 feet, or about 280 feet per millidegree. A table of size one thousand by one thousand, or one million cells, can contain the routing instructions for an area that is about 69 miles by 53 miles, which is larger than the area of  
20 Philadelphia in this example, and each cell could contain a geographic area of 365 feet by 280 feet. The number of bits allocated to each entry in the table must only be enough to support the maximum number of routing possibilities. For example, if the total number of routing possibilities is sixteen or less, then the memory for the dynamic routing table is one million times four bits, or one-half megabyte. Using this scheme, an area the size of  
25 Pennsylvania could be contained in a table of approximately twenty megabytes or less, with ample routing possibilities available. Given the relatively inexpensive cost of memory, this inventive dynamic routing table provides the AP 14 with a means to quickly push the location records for "911" calls only to the appropriate E9-1-1 network element.

30 The AP 14 allows each entry in dynamic routing to be populated using manual or automated means. Using the automated means, for example, an electronic map application can create a polygon definition of the coverage area of a specific E9-1-1 network element,

such as a PSAP. The polygon definition is then translated into a list of latitude, longitude points contained within the polygon. The dynamic routing table cell corresponding to each latitude, longitude point is then given the routing instruction for that E9-1-1 network element that is responsible for that geographic polygon.

5

When the Ap911 process receives a "911" location record for a specific wireless transmitter, Ap911 converts the latitude, longitude into the address of a specific cell in the dynamic routing table. Ap911 then queries the cell to determine the routing instructions, which may be push or pull mode and the identity of the E9-1-1 network element  
10 responsible for serving the geographic area in which the "911" call occurred. If push mode has been selected, then Ap911 automatically pushes the location record to that E9-1-1 network element. If pull mode has been selected, then Ap911 places the location record into a circular table of "911" location records and awaits a query.

15 The dynamic routing means described above entails the use of a geographically defined database that may be applied to other applications in addition to 911, and is therefore supported by other processes in addition to Ap911. For example, the AP 14 can automatically determine the billing zone from which a wireless call was placed for a Location Sensitive Billing application. In addition, the AP 14 may automatically send an  
20 alert when a particular wireless transmitter has entered or exited a prescribed geographic area defined by an application. The use of particular geographic databases, dynamic routing actions, any other location triggered actions are defined in the fields and flags associated with each trigger criteria. The Wireless Location System includes means to easily manage these geographically defined databases using an electronic map that can  
25 create polygons encompassing a prescribed geographic area. The Wireless Location System extracts from the electronic map a table of latitude, longitude points contained with the polygon. Each application can use its own set of polygons, and can define a set of actions to be taken when a location record for a triggered wireless transmission is contained within each polygon in the set.

30

The AP Database Receive Process (ApDbRecvLoc) receives all location records from ApMnDsptch via shared memory, and places the location records into the AP location

database. ApDbRecvLoc starts ten threads that each retrieve location records from shared memory, validate each record before inserting the records into the database, and then inserts the records into the correct location record partition in the database. To preserve integrity, location records with any type of error are not written into the location record database but are instead placed into an error file that can be reviewed by the Wireless Location System operator and then manually entered into the database after error resolution. If the location database has failed or has been placed into off-line status, location records are written to a flat file where they can be later processed by ApDbFileRecv.

10 The AP File Receive Process (ApDbFileRecv) reads flat files containing location records and inserts the records into the location database. Flat files are a safe mechanism used by the AP 14 to completely preserve the integrity of the AP 14 in all cases except a complete failure of the hard disk drives. There are several different types of flat files read by ApDbFileRecv, including Database Down, Synchronization, Overflow, and Fixed Error. Database Down flat files are written by the ApDbRecvLoc process if the location database is temporarily inaccessible; this file allows the AP 14 to ensure that location records are preserved during the occurrence of this type of problem. Synchronization flat files are written by the ApLocSync process (described below) when transferring location records between pairs of redundant AP systems. Overflow flat files are written by ApMnDsptch when location records are arriving into the AP 14 at a rate faster than ApDbRecvLoc can process and insert the records into the location database. This may occur during very high peak rate periods. The overflow files prevent any records from being lost during peak periods. The Fixed Error flat files contain location records that had errors but have now been fixed, and can now be inserted into the location database.

Because the AP 14 has a critical centralized role in the Wireless Location System, the AP 14 architecture has been designed to be fully redundant. A redundant AP 14 system includes fully redundant hardware platforms, fully redundant RDBMS, redundant disk drives, and redundant networks to each other, the TLP's 12, the NOC's 16, and external applications. The software architecture of the AP 14 has also been designed to support fault tolerant redundancy. The following examples illustrate functionality supported by the



redundant AP's. Each TLP 12 sends location records to both the primary and the redundant AP 14 when both AP's are in an online state. Only the primary AP 14 will process incoming tasking requests, and only the primary AP 14 will accept configuration change requests from the NOC 16. The primary AP 14 then synchronizes the redundant AP 14 under careful control. Both the primary and redundant AP's will accept basic startup and shutdown commands from the NOC. Both AP's constantly monitor their own system parameters and application health and monitor the corresponding parameters for the other AP 14, and then decide which AP 14 will be primary and which will be redundant based upon a composite score. This composite score is determined by compiling errors reported by various processes to a shared memory area, and monitoring swap space and disk space. There are several processes dedicated to supporting redundancy.

The AP Location Synchronization Process (ApLocSync) runs on each AP 14 and detects the need to synchronize location records between AP's, and then creates "sync records" that list the location records that need to be transferred from one AP 14 to another AP 14. The location records are then transferred between AP's using a socket connection. ApLocSync compares the location record partitions and the location record sequence numbers stored in each location database. Normally, if both the primary and redundant AP 14 are operating properly, synchronization is not needed because both AP's are receiving location records simultaneously from the TLP's 12. However, if one AP 14 fails or is placed in an off-line mode, then synchronization will later be required. ApLocSync is notified whenever ApMnDspch connects to a TLP 12 so it can determine whether synchronization is required.

The AP Tasking Synchronization Process (ApTaskSync) runs on each AP 14 and synchronizes the tasking information between the primary AP 14 and the redundant AP 14. ApTaskSync on the primary AP 14 receives tasking information from ApDbSend, and then sends the tasking information to the ApTaskSync process on the redundant AP 14. If the primary AP 14 were to fail before ApTaskSync had completed replicating tasks, then ApTaskSync will perform a complete tasking database synchronization when the failed AP 14 is placed back into an online state.

The AP Configuration Synchronization Process (ApConfigSync) runs on each AP 14 and synchronizes the configuration information between the primary AP 14 and the redundant AP 14. ApConfigSync uses a RDBMS replication facility. The configuration information includes all information needed by the SCS's 10, TLP's 12, and AP's 14 for proper  
5 operation of the Wireless Location System in a wireless carrier's network.

In addition to the core functions described above, the AP 14 also supports a large number of processes, functions, and interfaces useful in the operation of the Wireless Location System, as well as useful for various applications that desire location information. While  
10 the processes, functions, and interfaces described herein are in this section pertaining to the AP 14, the implementation of many of these processes, functions, and interfaces permeates the entire Wireless Location System and therefore their inventive value should be not read as being limited only to the AP 14.

#### 15 Roaming

The AP 14 supports "roaming" between wireless location systems located in different cities or operated by different wireless carriers. If a first wireless transmitter has subscribed to an application on a first Wireless Location System, and therefore has an entry in the Tasking List in the first AP 14 in the first Wireless Location System, then the  
20 first wireless transmitter may also subscribe to roaming. Each AP 14 and TLP 12 in each Wireless Location System contains a table in which a list of valid "home" subscriber identities is maintained. The list is typically a range, and for example, for current cellular telephones, the range can be determined by the NPA/NXX codes (or area code and exchange) associated with the MIN or MSID of cellular telephones. When a wireless  
25 transmitter meeting the "home" criteria makes a transmission, a TLP 12 receives demodulated data from one or more SCS's 10 and checks the trigger information in the Signal of Interest Table . If any trigger criterion is met, the location processing begins on that transmission; otherwise, the transmission is not processed by the Wireless Location System.

30

When a first wireless transmitter not meeting the "home" criterion makes a transmission in a second Wireless Location System, the second TLP 12 in the second Wireless Location

System checks the Signal of Interest Table for a trigger. One of three actions then occurs:

- (i) if the transmission meets an already existing criteria in the Signal of Interest Table, the transmitter is located and the location record is forwarded from the second AP 14 in the second Wireless Location System to the first AP 14 in the first Wireless Location System;
- 5 (ii) if the first wireless transmitter has a "roamer" entry in the Signal of Interest Table indicating that the first wireless transmitter has "registered" in the second Wireless Location System but has no trigger criteria, then the transmission is not processed by the second Wireless Location System and the expiration timestamp is adjusted as described below;
- 10 (iii) if the first wireless transmitter has no "roamer" entry and therefore has not "registered", then the demodulated data is passed from the TLP 12 to the second AP 14.

In the third case above, the second AP 14 uses the identity of the first wireless transmitter to identify the first AP 14 in the first Wireless Location System as the "home" Wireless Location System of the first wireless transmitter. The second AP 14 in the second Wireless Location System sends a query to the first AP 14 in the first Wireless Location System to

15 determine whether the first wireless transmitter has subscribed to any location application and therefore has any trigger criteria in the Tasking List of the first AP 14. If a trigger is present in the first AP 14, the trigger criteria, along with any associated fields and flags, is sent from the first AP 14 to the second AP 14 and entered in the Tasking List and the

20 Signal of Interest Table as a "roamer" entry with trigger criteria. If the first AP 14 responds to the second AP 14 indicating that the first wireless transmitter has no trigger criteria, then the second AP 14 "registers" the first wireless transmitter in the Tasking List and the Signal of Interest Table as a "roamer" with no trigger criteria. Thus both current and future transmissions from the first wireless transmitter can be positively identified by

25 the TLP 12 in the second Wireless Location System as being registered without trigger criteria, and the second AP 14 is not required to make additional queries to the first AP 14.

When the second AP 14 registers the first wireless transmitter with a roamer entry in the Tasking List and the Signal of Interest Table with or without trigger criteria, the roamer

30 entry is assigned an expiration timestamp. The expiration timestamp is set to the current time plus a predetermined first interval. Every time the first wireless transmitter makes a transmission, the expiration timestamp of the roamer entry in the Tasking List and the

Signal of Interest Table is adjusted to the current time of the most recent transmission plus the predetermined first interval. If the first wireless transmitter makes no further transmissions prior to the expiration timestamp of its roamer entry, then the roamer entry is automatically deleted. If, subsequent to the deletion, the first wireless transmitter makes another transmission, then the process of registering occurs again.

The first AP 14 and second AP 14 maintain communications over a wide area network. The network may be based upon TCP/IP or upon a protocol similar to the most recent version of IS-41. Each AP 14 in communications with other AP's in other wireless location systems maintains a table that provides the identity of each AP 14 and Wireless Location System corresponding to each valid range of identities of wireless transmitters.

#### Multiple Pass Location Records

Certain applications may require a very fast estimate of the general location of a wireless transmitter, followed by a more accurate estimate of the location that can be sent subsequently. This can be valuable, for example, for E9-1-1 systems that handle wireless calls and must make a call routing decision very quickly, but can wait a little longer for a more exact location to be displayed upon the E9-1-1 call-taker's electronic map terminal. The Wireless Location System supports these applications with an inventive multiple pass location processing mode, described later. The AP 14 supports this mode with multiple pass location records. For certain entries, the Tasking List in the AP 14 contains a flag indicating the maximum time limit before which a particular application must receive a rough estimate of location, and a second maximum time limit in which a particular application must receive a final location estimate. For these certain applications, the AP 14 includes a flag in the location record indicating the status of the location estimate contained in the record, which may, for example, be set to first pass estimate (i.e. rough) or final pass estimate. The Wireless Location System will generally determine the best location estimate within the time limit set by the application, that is the Wireless Location System will process the most amount of RF data that can be supported in the time limit. Given that any particular wireless transmission can trigger a location record for one or more applications, the Wireless Location System supports multiple modes simultaneously. For example, a wireless transmitter with a particular MIN can dial "911". This may trigger

a two-pass location record for the E9-1-1 application, but a single pass location record for a fleet management application that is monitoring that particular MIN. This can be extended to any number of applications.

5 Multiple Demodulation and Triggers

In wireless communications systems in urban or dense suburban areas, frequencies or channels can be re-used several times within relatively close distances. Since the Wireless Location System is capable of independently detecting and demodulating wireless transmissions without the aid of the wireless communications system, a single wireless transmission can frequently be detected and successfully demodulated at multiple SCS's 10 within the Wireless Location System. This can happen both intentionally and unintentionally. An unintentional occurrence is caused by a close frequency re-use, such that a particular wireless transmission can be received above a predetermined threshold at more than one SCS 10, when each SCS 10 believes it is monitoring only transmissions 15 that occur only within the cell site collocated with the SCS 10. An intentional occurrence is caused by programming more than one SCS 10 to detect and demodulate transmissions that occur at a particular cell site and on a particular frequency. As described earlier, this is generally used with adjacent or nearby SCS's 10 to provide system demodulation redundancy to further increase the probability that any particular wireless transmission is 20 successful detected and demodulated.

Either type of event could potentially lead to multiple triggers within the Wireless Location System, causing location processing to be initiated several times for the same transmission. This causes an excess and inefficient use of processing and communications 25 resources. Therefore, the Wireless Location System includes means to detect when the same transmission has been detected and demodulated more than once, and to select the best demodulating SCS 10 as the starting point for location processing. When the Wireless Location System detects and successfully demodulates the same transmission multiple times at multiple SCS/antennas, the Wireless Location System uses the following criteria 30 to select the one demodulating SCS/antenna to use to continue the process of determining whether to trigger and possibly initiate location processing (again, these criteria may be weighted in determining the final decision): (i) an SCS/antenna collocated at the cell site

to which a particular frequency has been assigned is preferred over another SCS/antenna, but this preference may be adjusted if there is no operating and on-line SCS/antenna collocated at the cell site to which the particular frequency has been assigned, (ii) SCS/antennas with higher average SNR are preferred over those with lower average SNR, and (iii) SCS/antennas with fewer bit errors in demodulating the transmission are preferred over those with higher bit errors. The weighting applied to each of these preferences may be adjusted by the operator of the Wireless Location System to suit the particular design of each system.

10 Interface to Wireless Communications System

The Wireless Location System contains means to communicate over an interface to a wireless communications system, such as a mobile switching center (MSC) or mobile positioning controller (MPC). This interface may be based, for example, on a standard secure protocol such as the most recent version of the IS-41 or TCP/IP protocols. The formats, fields, and authentication aspects of these protocols are well known. The Wireless Location System supports a variety of command / response and informational messages over this interface that are designed to aid in the successful detection, demodulation, and triggering of wireless transmissions, as well as providing means to pass location records to the wireless communications system. In particular, this interface provides means for the Wireless Location System to obtain information about which wireless transmitters have been assigned to particular voice channel parameters at particular cell sites. Example messages supported by the Wireless Location System over this interface to the wireless communications system include the following:

25 Query on MIN / MDN / MSID / IMSI / TMSI Mapping – Certain types of wireless transmitters will transmit their identity in a familiar form that can be dialed over the telephone network. Other types of wireless transmitters transmit an identity that cannot be dialed, but which is translated into a number that can be dialed using a table inside of the wireless communications system. The transmitted identity is permanent in most cases, but can also be temporary. Users of location applications connected to the AP 14 typically prefer to place triggers onto the Tasking List using identities that can be dialed. Identities that can be dialed are typically known as Mobile Directory Numbers

(MDN). The other types of identities for which translation may be required includes Mobile Identity Number (MIN), Mobile Subscriber Identity (MSID), International Mobile Subscriber Identity (IMSI), and Temporary Mobile Subscriber Identity (TMSI). If the wireless communications system has enabled the use of encryption for any of the data fields in the messages transmitted by wireless transmitters, the Wireless Location System may also query for encryption information along with the identity information. The Wireless Location System includes means to query the wireless communications system for the alternate identities for a trigger identity that has been placed onto the Tasking List by a location application, or to query the wireless communications system for alternate identities for an identity that has been demodulated by an SCS 10. Other events can also trigger this type of query. For this type of query, typically the Wireless Location System initiates the command, and the wireless communications system responds.

Query / Command Change on Voice RF Channel Assignment – Many wireless transmissions on voice channels do not contain identity information. Therefore, when the Wireless Location System is triggered to perform location processing on a voice channel transmission, the Wireless Location System queries the wireless communication system to obtain the current voice channel assignment information for the particular transmitter for which the Wireless Location System has been triggered. For an AMPS transmission, for example, the Wireless Location System preferably requires the cell site, sector, and RF channel number currently in use by the wireless transmitter. For a TDMA transmission, for example, the Wireless Location System preferably requires the cell site, sector, RF channel number, and timeslot currently in use by the wireless transmitter. Other information elements that may be needed includes long code mask and encryption keys. In general, the Wireless Location System will initiate the command, and the wireless communications system will respond. However, the Wireless Location System will also accept a trigger command from the wireless communications system that contains the information detailed herein.

The timing on this command / response message set is very critical since voice channel handoffs can occur quite frequently in wireless communications systems. That is, the Wireless Location System will locate any wireless transmitter that is transmitting on a particular channel – therefore the Wireless Location System and the wireless communications system must jointly be certain that the identity of the wireless transmitter and the voice channel assignment information are in perfect synchronization. The Wireless Location System uses several means to achieve this objective. The Wireless Location System may, for example, query the voice channel assignment information for a particular wireless transmitter, receive the necessary RF data, then again query the voice channel assignment information for that same wireless transmitter, and then verify that the status of the wireless transmitter did not change during the time in which the RF data was being collected by the Wireless Location System. Location processing is not required to complete before the second query, since it is only important to verify that the correct RF data was received. The Wireless Location System may also, for example, as part of the first query command the wireless communications system to prevent a handoff from occurring for the particular wireless transmitter during the time period in which the Wireless Location System is receiving the RF data. Then, subsequent to collecting the RF data, the Wireless Location System will again query the voice channel assignment information for that same wireless transmitter, command the wireless communications system to again permit handoffs for said wireless transmitter and then verify that the status of the wireless transmitter did not change during the time in which the RF data was being collected by the Wireless Location System.

For various reasons, either the Wireless Location System or the wireless communications system may prefer that the wireless transmitter be assigned to another voice RF channel prior to performing location processing. Therefore, as part of the command / response sequence, the wireless communications system may instruct the Wireless Location System to temporarily suspend location processing until the wireless communications system has completed a handoff sequence with the wireless transmitter, and the wireless communications system has notified the Wireless Location System that RF data can be received, and the voice RF channel upon which



the data can be received. Alternately, the Wireless Location System may determine that the particular voice RF channel which a particular wireless transmitter is currently using is unsuitable for obtaining an acceptable location estimate, and request that the wireless communications system command the wireless transmitter to handoff.

5 Alternately, the Wireless Location System may request that the wireless communications system command the wireless transmitter to handoff to a series of voice RF channels in sequence in order to perform a series of location estimates, whereby the Wireless Location System can improve upon the accuracy of the location estimate through the series of handoffs; this method is further described later.

10

The Wireless Location System can also use this command / response message set to query the wireless communications system about the identity of a wireless transmitter that had been using a particular voice channel (and timeslot, etc.) at a particular cell site at a particular time. This enables the Wireless Location System to first perform location processing on transmissions without knowing the identities, and then to later determine the identity of the wireless transmitters making the transmissions and append this information to the location record. This particular inventive feature enables the use of automatic sequential location of voice channel transmissions.

15

20 Receive Triggers – The Wireless Location System can receive triggers from the wireless communications system to perform location processing on a voice channel transmission without knowing the identity of the wireless transmitter. This message set bypasses the Tasking List, and does not use the triggering mechanisms within the Wireless Location System. Rather, the wireless communications system alone determines which wireless transmissions to locate, and then send a command to the Wireless Location System to collect RF data from a particular voice channel at a particular cell site and to perform location processing. The Wireless Location System responds with a confirmation containing a timestamp when the RF data was collected. The Wireless Location System also responds with an appropriate format location record when location processing has completed. Based upon the time of the command to Wireless Location System and the response with the RF data collection timestamp, the wireless communications system determines whether the wireless transmitter status

25

30

changed subsequent to the command and whether there is a good probability of successful RF data collection.

5       **Make Transmit** – The Wireless Location System can command the wireless communications system to force a particular wireless transmitter to make a transmission at a particular time, or within a prescribed range of times. The wireless communications system responds with a confirmation and a time or time range in which to expect the transmission. The types of transmissions that the Wireless Location System can force include, for example, audit responses and page responses.

10       Using this message set, the Wireless Location System can also command the wireless communications system to force the wireless transmitter to transmit using a higher power level setting. In many cases, wireless transmitters will attempt to use the lowest power level settings when transmitting in order to conserve battery life. In order to improve the accuracy of the location estimate, the Wireless Location System may

15       prefer that the wireless transmitter use a higher power level setting. The wireless communications system will respond to the Wireless Location System with a confirmation that the higher power level setting will be used and a time or time range in which to expect the transmission.

20       **Delay Wireless Communications System Response to Mobile Access** – Some air interface protocols, such as CDMA, use a mechanism in which the wireless transmitter initiates transmissions on a channel, such as an Access Channel, for example, at the lowest or a very low power level setting, and then enters a sequence of steps in which

25       (i) the wireless transmitter makes an access transmission; (ii) the wireless transmitter waits for a response from the wireless communications system; (iii) if no response is received by the wireless transmitter from the wireless communications system within a predetermined time, the wireless transmitter increases its power level setting by a predetermined amount, and then returns to step (i); (iv) if a response is received by the wireless transmitter from the wireless communications system within a predetermined

30       time, the wireless transmitter then enters a normal message exchange. This mechanism is useful to ensure that the wireless transmitter uses only the lowest useful power level setting for transmitting and does not further waste energy or battery life. It is possible,

however, that the lowest power level setting at which the wireless transmitter can successfully communicate with the wireless communications system is not sufficient to obtain an acceptable location estimate. Therefore, the Wireless Location System can command the wireless communications system to delay its response to these  
5 transmissions by a predetermined time or amount. This delaying action will cause the wireless transmitter to repeat the sequence of steps (i) through (iii) one or more times than normal with the result that one or more of the access transmissions will be at a higher power level than normal. The higher power level may preferably enable the Wireless Location System to determine a more accurate location estimate. The  
10 Wireless Location System may command this type of delaying action for either a particular wireless transmitter, for a particular type of wireless transmission (for example, for all '911' calls), for wireless transmitters that are at a specified range from the base station to which the transmitter is attempting to communicate, or for all wireless transmitters in a particular area.

15

Send Confirmation to Wireless Transmitter – The Wireless Location System does not include means within to notify the wireless transmitter of an action because the Wireless Location System cannot transmit; as described earlier the Wireless Location System can only receive transmissions. Therefore, if the Wireless Location System  
20 desires to send, for example, a confirmation tone upon the completion of a certain action, the Wireless Location System commands the wireless communications system to transmit a particular message. The message may include, for example, an audible confirmation tone, spoken message, or synthesized message to the wireless transmitter, or a text message sent via a short messaging service or a page. The Wireless Location  
25 System receives confirmation from the wireless communications system that the message has been accepted and sent to the wireless transmitter. This command / response message set is important in enabling the Wireless Location System to support certain end-user application functions such as Prohibit Location Processing.

30

Report Location Records – The Wireless Location System automatically reports location records to the wireless communications system for those wireless transmitters tasked to report to the wireless communications system, as well as for those

transmissions that the wireless communications system initiated triggers. The Wireless Location System also reports on any historical location record queried by the wireless communications system and which the wireless communications system is authorized to receive.

5

Monitor Internal Wireless Communications System Interfaces, State Table

In addition to this above interface between the Wireless Location System and the wireless communications system, the Wireless Location System also includes means to monitor existing interfaces within the wireless communications system for the purpose of  
10 intercepting messages important to the Wireless Location System for identifying wireless transmitters and the RF channels in use by these transmitters. These interfaces may include, for example, the "a-interface" and "a-bis interface" used in wireless communications systems employing the GSM air interface protocol. These interfaces are well-known and published in various standards. By monitoring the bi-directional messages  
15 on these interfaces between base stations (BTS), base station controllers (BSC), and mobile switching centers (MSC), and other points, the Wireless Location System can obtain the same information about the assignment of wireless transmitters to specific channels as the wireless communications system itself knows. The Wireless Location System includes means to monitor these interfaces at various points. For example, the SCS  
20 10 may monitor a BTS to BSC interface. Alternately, a TLP 12 or AP 14 may also monitor a BSC where a number of BTS to BSC interfaces have been concentrated. The interfaces internal to the wireless communications system are not encrypted and the layered protocols are known to those familiar with the art. The advantage to the Wireless Location System to monitoring these interfaces is that the Wireless Location System may not be  
25 required to independently detect and demodulate control channel messages from wireless transmitters. In addition, the Wireless Location System may obtain all necessary voice channel assignment information from these interfaces.

Using these means for a control channel transmission, the SCS 10 receives the  
30 transmissions as described earlier and records the control channel RF data into memory without performing detection and demodulation. Separately, the Wireless Location System monitors the messages occurring over prescribed interfaces within the wireless

communications system, and causes a trigger in the Wireless Location System when the Wireless Location System discovers a message containing a trigger event. Initiated by the trigger event, the Wireless Location System determines the approximately time at which the wireless transmission occurred, and commands a first SCS 10A and a second SCS 10B to each search its memory for the start of transmission. This first SCS 10A chosen is an SCS that is either collocated with the base station to which the wireless transmitter had communicated, or an SCS which is adjacent to the base station to which the wireless transmitter had communicated. That is, the first SCS 10A is an SCS which would have been assigned the control channel as a primary channel. If the first SCS 10A successfully determines and reports the start of the transmission, then location processing proceeds normally, using the means described below. If the first SCS 10A cannot successfully determine the start of transmission, then the second SCS 10B reports the start of transmission, and then location processing proceeds normally.

The Wireless Location System also uses these means for voice channel transmissions. For all triggers contained in the Tasking List, the Wireless Location System monitors the prescribed interfaces for messages pertaining to those triggers. The messages of interest include, for example, voice channel assignment messages, handoff messages, frequency hopping messages, power up / power down messages, directed re-try messages, termination messages, and other similar action and status messages. The Wireless Location System continuously maintains a copy of the state and status of these wireless transmitters in a State Table in the AP 14. Each time that the Wireless Location System detects a message pertaining to one of the entries in the Tasking List, the Wireless Location System updates its own State Table. Thereafter, the Wireless Location System may trigger to perform location processing, such as on a regular time interval, and access the State Table to determine precisely which cell site, sector, RF channel, and timeslot is presently being used by the wireless transmitter. The example contained herein described the means by which the Wireless Location System interfaces to a GSM based wireless communications system. The Wireless Location System also supports similar functions with systems based upon other air interfaces.

For certain air interfaces, such as CDMA, the Wireless Location System also keeps certain identity information obtained from Access bursts in the control channel in the State Table; this information is later used for decoding the masks used for voice channels. For example, the CDMA air interface protocol uses the Electronic Serial Number (ESN) of a wireless transmitter to, in part, determine the long code mask used in the coding of voice channel transmissions. The Wireless Location System maintains this information in the State Table for entries in the Tasking List because many wireless transmitters may transmit the information only once; for example, many CDMA mobiles will only transmit their ESN during the first Access burst after the wireless transmitter become active in a geographic area. This ability to independently determine the long code mask is very useful in cases where an interface between the Wireless Location System and the wireless communications system is not operative and/or the Wireless Location System is not able to monitor one of the interfaces internal to the wireless communications system. The operator of the Wireless Location System may optionally set the Wireless Location System to maintain the identity information for all wireless transmitters. In addition to the above reasons, the Wireless Location System can provide the voice channel tracking for all wireless transmitters that trigger location processing by calling "911". As described earlier, the Wireless Location System uses dynamic tasking to provide location to a wireless transmitter for a prescribed time after dialing "911", for example. By maintaining the identity information for all wireless transmitters in the State Table, the Wireless Location System is able to provide voice channel tracking for all transmitters in the event of a prescribed trigger event, and not just those with prior entries in the Tasking List.

#### Applications Interface

Using the AP 14, the Wireless Location System supports a variety of standards based interfaces to end-user and carrier location applications using secure protocols such as TCP/IP, X.25, SS-7, and IS-41. Each interface between the AP 14 and an external application is a secure and authenticated connection that permits the AP 14 to positively verify the identity of the application that is connected to the AP 14. This is necessary because each connected application is granted only limited access to location records on a real-time and/or historical basis. In addition, the AP 14 supports additional command / response, real-time, and post-processing functions that are further detailed below. Access

to these additional functions also requires authentication. The AP 14 maintains a user list and the authentication means associated with each user. No application can gain access to location records or functions for which the application does not have proper authentication or access rights. In addition, the AP 14 supports full logging of all actions taken by each application in the event that problems arise or a later investigation into actions is required. For each command or function in the list below, the AP 14 preferably supports a protocol in which each action or the result of each is confirmed, as appropriate.

10 Edit Tasking List – This command permits external applications to add, remove, or edit entries in the Tasking List, including any fields and flags associated with each entry. This command can be supported on a single entry basis, or a batch entry basis where a list of entries is included in a single command. The latter is useful, for example, in a bulk application such as location sensitive billing whereby larger volumes of wireless transmitters are being supported by the external application, and it is desired to minimize protocol overhead. This command can add or delete applications for a particular entry in the Tasking List, however, this command cannot delete an entry entirely if the entry also contains other applications not associated with or authorized by the application issuing the command.

20 Set Location Interval – The Wireless Location System can be set to perform location processing at any interval for a particular wireless transmitter, on either control or voice channels. For example, certain applications may require the location of a wireless transmitter every few seconds when the transmitter is engaged on a voice channel. When the wireless transmitter make an initial transmission, the Wireless Location System initially triggers using a standard entry in the Tasking List. If one of the fields or flags in this entry specifies updated location on a set interval, then the Wireless Location System creates a dynamic task in the Tasking List that is triggered by a timer instead of an identity or other transmitted criteria. Each time the timer expires, which can range from 1 second to several hours, the Wireless Location System will automatically trigger to locate the wireless transmitter. The Wireless Location System uses its interface to the wireless communications system to query status of the wireless transmitter, including voice call parameters as described earlier.

If the wireless transmitter is engaged on a voice channel, then the Wireless Location System performs location processing. If the wireless transmitter is not engaged in any existing transmissions, the Wireless Location System will command the wireless communications system to make the wireless transmitter immediately transmit. When  
5 the dynamic task is set, the Wireless Location System also sets an expiration time at which the dynamic task ceases.

End-User Addition / Deletion – This command can be executed by an end-user of a wireless transmitter to place the identity of the wireless transmitter onto the Tasking  
10 List with location processing enabled, to remove the identity of the wireless transmitter from the Tasking List and therefore eliminate identity as a trigger, or to place the identity of the wireless transmitter onto the Tasking List with location processing disabled. When location processing has been disabled by the end-user, known as Prohibit Location Processing then no location processing will be performed for the  
15 wireless transmitter. The operator of the Wireless Location System can optionally select one of several actions by the Wireless Location System in response to a Prohibit Location Processing command by the end user: (i) the disabling action can override all other triggers in the Tasking List, including a trigger due to an emergency call such as “911”, (ii) the disabling action can override any other trigger in the Tasking List,  
20 except a trigger due to an emergency call such as “911”, (iii) the disabling action can be overridden by other select triggers in the Tasking List. In the first case, the end-user is granted complete control over the privacy of the transmissions by the wireless transmitter, as no location processing will be performed on that transmitter for any reason. In the second case, the end-user may still receive the benefits of location  
25 during an emergency, but at no other times. In an example of the third case, an employer who is the real owner of a particular wireless transmitter can override an end-user action by an employee who is using the wireless transmitter as part of the job but who may not desire to be located. The Wireless Location System may query the wireless communications system, as described above, to obtain the mapping of the  
30 identity contained in the wireless transmission to other identities.



The additions and deletions by the end-user are effected by dialed sequences of characters and digits and pressing the "SEND" or equivalent button on the wireless transmitter. These sequences may be optionally chosen and made known by the operator of the Wireless Location System. For example, one sequence may be "\*55 SEND" to disable location processing. Other sequences are also possible. When the end-user can dialed this prescribed sequence, the wireless transmitter will transmit the sequence over one of the prescribed control channels of the wireless communications system. Since the Wireless Location System independently detects and demodulates all reverse control channel transmissions, the Wireless Location System can independently interpret the prescribed dialed sequence and make the appropriate feature updates to the Tasking List, as described above. When the Wireless Location System has completed the update to the Tasking List, the Wireless Location System commands the wireless communications system to send a confirmation to the end-user. As described earlier, this may take the form of an audible tone, recorded or synthesized voice, or a text message. This command is executed over the interface between the Wireless Location System and the wireless communications system.

Command Transmit – This command allows external applications to cause the Wireless Location System to send a command to the wireless communications system to make a particular wireless transmitter, or group of wireless transmitters, transmit. This command may contain a flag or field that the wireless transmitter(s) should transmit immediately or at a prescribed time. This command has the effect of locating the wireless transmitter(s) upon command, since the transmissions will be detected, demodulated, and triggered, causing location processing and the generation of a location record. This is useful in eliminating or reducing any delay in determining location such as waiting for the next registration time period for the wireless transmitter or waiting for an independent transmission to occur.

External Database Query and Update – The Wireless Location System includes means to access an external database, to query the said external database using the identity of the wireless transmitter or other parameters contained in the transmission or the trigger criteria, and to merge the data obtained from the external database with the data

generated by the Wireless Location System to create a new enhanced location record. The enhanced location record may then be forwarded to requesting applications. The external database may contain, for example, data elements such as customer information, medical information, subscribed features, application related information, customer account information, contact information, or sets of prescribed actions to take upon a location trigger event. The Wireless Location System may also cause updates to the external database, for example, to increment or decrement a billing counter associated with the provision of location services, or to update the external database with the latest location record associated with the particular wireless transmitter. The Wireless Location System contains means to performed the actions described herein on more than one external database. The list and sequence of external databases to access and the subsequent actions to take are contained in one of the fields contained in the trigger criteria in the Tasking List.

Random Anonymous Location Processing – The Wireless Location System includes means to perform large scale random anonymous location processing. This function is valuable to certain types of applications that require the gathering of a large volume of data about a population of wireless transmitters without consideration to the specific identities of the individual transmitters. Applications of this type include: RF Optimization, which enables wireless carriers to measure the performance of the wireless communications system by simultaneously determining location and other parameters of a transmission; Traffic Management, which enables government agencies and commercial concerns to monitor the flow of traffic on various highways using statistically significant samples of wireless transmitters travelling in vehicles; and Local Traffic Estimation, which enables commercial enterprises to estimate the flow of traffic around a particular area which may help determine the viability of particular businesses.

Applications requesting random anonymous location processing optionally receive location records from two sources: (i) a copy of location records generated for other applications, and (ii) location records which have been triggered randomly by the Wireless Location System without regard to any specific criteria. All of the location

records generated from either source are forwarded with all of the identity and trigger criteria information removed from the location records; however, the requesting application(s) can determine whether the record was generated from the fully random process or is a copy from another trigger criteria. The random location records are  
5 generated by a low priority task within the Wireless Location System that performs location processing on randomly selected transmissions whenever processing and communications resources are available and would otherwise be unused at a particular instant in time. The requesting application(s) can specify whether the random location processing is performed over the entire coverage area of a Wireless Location System,  
10 over specific geographic areas such as along prescribed highways, or by the coverage areas of specific cell sites. Thus, the requesting application(s) can direct the resources of the Wireless Location System to those area of greatest interest to each application. Depending on the randomness desired by the application(s), the Wireless Location System can adjust preferences for randomly selecting certain types of transmissions,  
15 for example, registration messages, origination messages, page response messages, or voice channel transmissions.

Anonymous Tracking of a Geographic Group – The Wireless Location System includes means to trigger location processing on a repetitive basis for anonymous  
20 groups of wireless transmitters within a prescribed geographic area. For example, a particular location application may desire to monitor the travel route of a wireless transmitter over a prescribed period of time, but without the Wireless Location System disclosing the particular identity of the wireless transmitter. The period of time may be many hours, days, or weeks. Using the means, the Wireless Location System:  
25 randomly selects a wireless transmitter that initiates a transmission in the geographic area of interest to the application; performs location processing on the transmission of interest; irreversibly translates and encrypts the identity of the wireless transmitter into a new coded identifier; creates a location record using only the new coded identifier as an identifying means; forwards the location record to the requesting location  
30 application(s); and creates a dynamic task in the Tasking List for the wireless transmitter, where the dynamic task has an associated expiration time. Subsequently, whenever the prescribed wireless transmitter initiates transmission, the Wireless

Location System shall trigger using the dynamic task, perform location processing on the transmission of interest, irreversibly translate and encrypt the identity of the wireless transmitter into the new coded identifier using the same means as prior such that the coded identifier is the same, create a location record using the coded identifier, and forward the location record to the requesting location application(s). The means described herein can be combined with other functions of the Wireless Location System to perform this type of monitoring use either control or voice channel transmissions. Further, the means described herein completely preserve the private identity of the wireless transmitter, yet enables another class of applications that can monitor the travel patterns of wireless transmitters. This class of applications can be of great value in determining the planning and design of new roads, alternate route planning, or the construction of commercial and retail space.

Location Record Grouping, Sorting, and Labeling – The Wireless Location System include means to post-process the location records for certain requesting applications to group, sort, or label the location records. For each interface supported by the Wireless Location System, the Wireless Location System stores a profile of the types of data for which the application is both authorized and requesting, and the types of filters or post-processing actions desired by the application. Many applications, such as the examples contained herein, do not require individual location records or the specific identities of individual transmitters. For example, an RF optimization application derives more value from a large data set of location records for a particular cell site or channel than it can from any individual location record. For another example, a traffic monitoring application requires only location records from transmitters that are on prescribed roads or highways, and additionally requires that these records be grouped by section of road or highway and by direction of travel. Other applications may request that the Wireless Location System forward location records that have been formatted to enhance visual display appeal by, for example, adjusting the location estimate of the transmitter so that the transmitter's location appears on an electronic map directly on a drawn road segment rather than adjacent to the road segment. Therefore, the Wireless Location System preferably "snaps" the location estimate to the nearest drawn road segment.

The Wireless Location System can filter and report location records to an application for wireless transmitters communicating only on a particular cell site, sector, RF channel, or group of RF channels. Before forwarding the record to the requesting application, the Wireless Location System first verifies that the appropriate fields in the record satisfy the requirements. Records not matching the requirements are not forwarded, and records matching the requirements are forwarded. Some filters are geographic and must be calculated by the Wireless Location System. For example, the Wireless Location System can process a location record to determine the closest road segment and direction of travel of the wireless transmitter on the road segment. The Wireless Location System can then forward only records to the application that are determined to be on a particular road segment, and can further enhance the location record by adding a field containing the determined road segment. In order to determine the closest road segment, the Wireless Location System is provided with a database of road segments of interest by the requesting application. This database is stored in a table where each road segment is stored with a latitude and longitude coordinate defining the end point of each segment. Each road segment can be modeled as a straight or curved line, and can be modeled to support one or two directions of travel. Then for each location record determined by the Wireless Location System, the Wireless Location System compares the latitude and longitude in the location record to each road segment stored in the database, and determines the shortest distance from a modeled line connecting the end points of the segment to the latitude and longitude of the location record. The shortest distance is a calculated imaginary line orthogonal to the line connecting the two end points of the stored road segment. When the closest road segment has been determined, the Wireless Location System can further determine the direction of travel on the road segment by comparing the direction of travel of the wireless transmitter reported by the location processing to the orientation of the road segment. The direction that produces the smallest error with respect to the orientation of the road segments is then reported by the Wireless Location System.

30

#### Network Operations Console (NOC) 16

The NOC 16 is a network management system that permits operators of the Wireless Location System easy access to the programming parameters of the Wireless Location System. For example, in some cities, the Wireless Location System may contain many  
5 hundreds or even thousands of SCS's 10. The NOC is the most effective way to manage a large Wireless Location System, using graphical user interface capabilities. The NOC will also receive real time alerts if certain functions within the Wireless Location System are not operating properly. These real time alerts can be used by the operator to take corrective action quickly and prevent a degradation of location service. Experience with  
10 trials of the Wireless Location System show that the ability of the system to maintain good location accuracy over time is directly related to the operator's ability to keep the system operating within its predetermined parameters.

#### Location Processing

15 The Wireless Location System is capable of performing location processing using two different methods known as central based processing and station based processing. Both techniques were first disclosed in Patent Number 5,327,144, and are further enhanced in this specification. Location processing depends in part on the ability to accurately determine certain phase characteristics of the signal as received at multiple antennas and at  
20 multiple SCS's 10. Therefore, it is an object of the Wireless Location System to identify and remove sources of phase error that impede the ability of the location processing to determine the phase characteristics of the received signal. One source of phase error is inside of the wireless transmitter itself, namely the oscillator (typically a crystal oscillator) and the phase lock loops that allow the phone to tune to specific channels for transmitting.  
25 Lower cost crystal oscillators will generally have higher phase noise. Some air interface specifications, such as IS-136 and IS-95A, have specifications covering the phase noise with which a wireless telephone can transmit. Other air interface specifications, such as IS-553A, do not closely specify phase noise. It is therefore an object of the present invention to automatically reduce and/or eliminate a wireless transmitter's phase noise as a  
30 source of phase error in location processing, in part by automatically selecting the use of central based processing or station based processing. The automatic selection will also

consider the efficiency with which the communications link between the SCS 10 and the TLP 12 is used, and the availability of DSP resources at each of the SCS 10 and TLP 12.

When using central based processing, the TDOA and FDOA determination and the multipath processing are performed in the TLP 12 along with the position and speed determination. This method is preferred when the wireless transmitter has a phase noise that is above a predetermined threshold. In these cases, central based processing is most effective in reducing or eliminating the phase noise of the wireless transmitter as a source of phase error because the TDOA estimate is performed using a digital representation of the actual RF transmission from two antennas, which may be at the same SCS 10 or different SCS's 10. In this method, those skilled in the art will recognize that the phase noise of the transmitter is a common mode noise in the TDOA processing, and therefore is self-canceling in the TDOA determination process. This method works best, for example, with many very low cost AMPS cellular telephones that have a high phase noise. The basic steps in central based processing include the steps recited below and represented in the flowchart of Figure 6:

a wireless transmitter initiates a transmission on either a control channel or a voice channel (step S50);  
the transmission is received at multiple antennas and at multiple SCS's 10 in the Wireless Location System (step S51);  
the transmission is converted into a digital format in the receiver connected to each SCS/antenna (step S52);  
the digital data is stored in a memory in the receivers in each SCS 10 (step S53);  
the transmission is demodulated (step S54);  
the Wireless Location System determines whether to begin location processing for the transmission (step S55);  
if triggered, the TLP 12 requests copies of the digital data from the memory in receivers at multiple SCS's 10 (step S56);  
digital data is sent from multiple SCS's 10 to a selected TLP 12 (step S57);  
the TLP 12 performs TDOA, FDOA, and multipath mitigation on the digital data from pairs of antennas (step S58);

the TLP 12 performs position and speed determination using the TDOA data, and then creates a location record and forwards the location record to the AP 14 (step S59).

5 The Wireless Location System uses a variable number of bits to represent the transmission when sending digital data from the SCS's 10 to the TLP 12. As discussed earlier, the SCS receiver digitizes wireless transmissions with a high resolution, or a high number of bits per digital sample in order to achieve a sufficient dynamic range. This is especially required when using wideband digital receivers, which may be simultaneously receiving signals near to the SCS 10A and far from the SCS 10B. For example, up to 14 bits may be  
10 required to represent a dynamic range of 84 dB. Location processing does not always require the high resolution per digital sample, however. Frequently, locations of sufficient accuracy are achievable by the Wireless Location System using a fewer number of bits per digital sample. Therefore, to minimize the implementation cost of the Wireless Location System by conserving bandwidth on the communication links between each SCS 10 and  
15 TLP 12, the Wireless Location System determines the fewest number of bits required to digitally represent a transmission while still maintaining a desired accuracy level. This determination is based, for example, on the particular air interface protocol used by the wireless transmitter, the SNR of the transmission, the degree to which the transmission has been perturbed by fading and/or multipath, and the current state of the processing and  
20 communication queues in each SCS 10. The number of bits sent from the SCS 10 to the TLP 12 are reduced in two ways: the number of bits per sample is minimized, and the shortest length, or fewest segments, of the transmission possible is used for location processing. The TLP 12 can use this minimal RF data to perform location processing and then compare the result with the desired accuracy level. This comparison is performed on  
25 the basis of a confidence interval calculation. If the location estimate does not fall within the desired accuracy limits, the TLP 12 will recursively request additional data from selected SCS's 10. The additional data may include an additional number of bits per digital sample and/or may include more segments of the transmission. This process of requesting additional data may continue recursively until the TLP 12 has achieved the  
30 prescribed location accuracy.



There are additional details to the basic steps described above. These details are described in prior Patent Numbers 5,327,144 and 5,608,410 in other parts of this specification. One enhancement to the processes described in earlier patents is the selection of a single reference SCS/antenna that is used for each baseline in the location processing. In prior  
 5 art, baselines were determined using pairs of antenna sites around a ring. In the present Wireless Location System, the single reference SCS/antenna used is generally the highest SNR signal, although other criteria are also used as described below. The use of a high SNR reference aids central based location processing when the other SCS/antennas used in the location processing are very weak, such as at or below the noise floor (i.e. zero or  
 10 negative signal to noise ratio). When station based location processing is used, the reference signal is a re-modulated signal, which is intentionally created to have a very high signal to noise ratio, further aiding location processing for very weak signals at other SCS/antennas. The actual selection of the reference SCS/antenna is described below.

15 The Wireless Location System mitigates multipath by first recursively estimating the components of multipath received in addition to the direct path component and then subtracting these components from the received signal. Thus the Wireless Location System models the received signal and compares the model to the actual received signal and attempts to minimize the difference between the two using a weighted least square  
 20 difference. For each transmitted signal  $x(t)$  from a wireless transmitter, the received signal  $y(t)$  at each SCS/antenna is a complex combination of signals:

$$y(t) = \sum x(t - \tau_n) a_n e^{j\omega(t - \tau_n)}, \text{ for all } n = 0 \text{ to } N;$$

25 where  $x(t)$  is the signal as transmitted by the wireless transmitter;  
 $a_n$  and  $\tau_n$  are the complex amplitude and delays of the multipath components;  
 $N$  is the total number of multipath components in the received signal; and  
 $a_0$  and  $\tau_0$  are constants for the most direct path component.

30 The operator of the Wireless Location System empirically determines a set of constraints for each component of multipath that applies to the specific environment in which each Wireless Location System is operating. The purpose of the constraints is to limit the

amount of processing time that the Wireless Location System spends optimizing the results for each multipath mitigation calculation. For example, the Wireless Location System may be set to determine only four components of multipath: the first component may be assumed to have a time delay in the range  $\tau_{1A}$  to  $\tau_{1B}$ ; the second component may  
5 be assumed to have a time delay in the range  $\tau_{2A}$  to  $\tau_{2B}$ ; the third component may be assumed to have a time delay in the range  $\tau_{3A}$  to  $\tau_{3B}$ ; and similar for the fourth component; however the fourth component is a single value that effectively represents a complex combination of many tens of individual (and somewhat diffuse) multipath components whose time delays exceed the range of the third component. For ease of  
10 processing, the Wireless Location System transforms the prior equation into the frequency domain, and then solves for the individual components such that a weighted least squares difference is minimized.

When using station based processing, the TDOA and FDOA determination and multipath  
15 mitigation are performed in the SCS's 10, while the position and speed determination are typically performed in the TLP 12. The main advantage of station based processing, as described in Patent Number 5,327,144, is reducing the amount of data that is sent on the communication link between each SCS 10 and TLP 12. However, there may be other advantages as well. One new objective of the present invention is increasing the effective  
20 signal processing gain during the TDOA processing. As pointed out earlier, central based processing has the advantage of eliminating or reducing phase error caused by the phase noise in the wireless transmitter. However, no previous disclosure has addressed how to eliminate or reduce the same phase noise error when using station based processing. The present invention reduces the phase error and increases the effective signal processing gain  
25 using the steps recited below and shown in Figure 6:

a wireless transmitter initiates a transmission on either a control channel or a voice channel (step S60);  
the transmission is received at multiple antennas and at multiple SCS's 10 in the  
30 Wireless Location System (step S61);  
the transmission is converted into a digital format in the receiver connected to each antenna (step S62);

the digital data is stored in a memory in the SCS 10 (step S63);  
the transmission is demodulated (step S64);  
the Wireless Location System determines whether to begin location processing for the  
transmission (step S65);  
5 if triggered, a first SCS 10A demodulates the transmission and determines an  
appropriate phase correction interval (step S66);  
for each such phase correction interval, the first SCS 10A calculates an appropriate  
phase correction and amplitude correction, and encodes this phase correction  
parameter and amplitude correction parameter along with the demodulated data (step  
10 S67);  
the demodulated data and phase correction and amplitude correction parameters are sent  
from the first SCS 10A to a TLP 12 (step S68);  
the TLP 12 determines the SCS's 10 and receiving antennas to use in the location  
processing (step S69);  
15 the TLP 12 sends the demodulated data and phase correction and amplitude correction  
parameters to each second SCS 10B that will be used in the location processing (step  
S70);  
the first SCS 10 and each second SCS 10B creates a first re-modulated signal based  
upon the demodulated data and the phase correction and amplitude correction  
20 parameters (step S71);  
the first SCS 10A and each second SCS 10B performs TDOA, FDOA, and multipath  
mitigation using the digital data stored in memory in each SCS 10 and the first re-  
modulated signal (step S72);  
the TDOA, FDOA, and multipath mitigation data are sent from the first SCS 10A and  
25 each second SCS 10B to the TLP 12 (step S73);  
the TLP 12 performs position and speed determination using the TDOA data (step S74);  
and  
the TLP 12 creates a location record, and forwards the location record to the AP 14 (step  
S75).

30

The advantages of determining phase correction and amplitude correction parameters are most obvious in the location of CDMA wireless transmitters based upon IS-95A. As is

well known, the reverse transmissions from an IS-95A transmitter are sent using non-coherent modulation. Most CDMA base stations only integrate over a single bit interval because of the non-coherent modulation. For a CDMA Access Channel, with a bit rate of 4800 bits per second, there are 256 chips sent per bit, which permits an integration gain of 24 dB. Using the technique described above, the TDOA processing in each SCS 10 may integrate, for example, over a full 160 millisecond burst (196,608 chips) to produce an integration gain of 53 dB. This additional processing gain enables the present invention to detect and locate CDMA transmissions using multiple SCS's 10, even if the base stations collocated with the SCS's 10 cannot detect the same CDMA transmission.

10

For a particular transmission, if either the phase correction parameters or the amplitude correction parameters are calculated to be zero, or are not needed, then these parameters are not sent in order to conserve on the number of bits transmitted on the communications link between each SCS 10 and TLP 12. In another embodiment of the invention, the Wireless Location System may use a fixed phase correction interval for a particular transmission or for all transmissions of a particular air interface protocol, or for all transmissions made by a particular type of wireless transmitter. This may, for example, be based upon empirical data gathered over some period of time by the Wireless Location System showing a reasonable consistency in the phase noise exhibited by various classes of transmitters. In these cases, the SCS 10 may save the processing step of determining the appropriate phase correction interval.

Those skilled in the art will recognize that there are many ways of measuring the phase noise of a wireless transmitter. In one embodiment, a pure, noiseless re-modulated copy of the signal received at the first SCS 10A may be digitally generated by DSP's in the SCS, then the received signal may be compared against the pure signal over each phase correction interval and the phase difference may be measured directly. In this embodiment, the phase correction parameter will be calculated as the negative of the phase difference over that phase correction interval. The number of bits required to represent the phase correction parameter will vary with the magnitude of the phase correction parameter, and the number of bits may vary for each phase correction interval. It has been

25  
30

observed that some transmissions, for example, exhibit greater phase noise early in the transmission, and less phase noise in the middle of and later in the transmission.

Station based processing is most useful for wireless transmitters that have relatively low  
5 phase noise. Although not necessarily required by their respective air interface standards,  
wireless telephones that use the TDMA, CDMA, or GSM protocols will typically exhibit  
lower phase noise. As the phase noise of a wireless transmitter increases, the length of a  
phase correction interval may decrease and/or the number of bits required to represent the  
10 phase correction parameters increases. Station based processing is not effective when the  
number of bits required to represent the demodulated data plus the phase correction and  
amplitude parameters exceeds a predetermined proportion of the number of bits required  
to perform central based processing. It is therefore an object of the present invention to  
automatically determine for each transmission for which a location is desired whether to  
15 process the location using central based processing or station based processing. The steps  
in making this determination are recited below and shown in Figure 7:

a wireless transmitter initiates a transmission on either a control channel or a voice  
channel (step S80);  
the transmission is received at a first SCS 10A (step S81);  
20 the transmission is converted into a digital format in the receiver connected to each  
antenna (step S82);  
the Wireless Location System determines whether to begin location processing for the  
transmission (step S83);  
if triggered, a first SCS 10A demodulates the transmission and estimates an appropriate  
25 phase correction interval and the number of bits required to encode the phase  
correction and amplitude correction parameters (step S84);  
the first SCS 10A then estimates the number of bits required for central based  
processing;  
based upon the number of bits required for each respective method, the SCS 10 or the  
30 TLP 12 determine whether to use central based processing or station based processing  
to perform the location processing for this transmission (step S85).

In another embodiment of the invention, the Wireless Location System may always use central based processing or station based processing for all transmissions of a particular air interface protocol, or for all transmissions made by a particular kind of wireless transmitter. This may, for example, be based upon empirical data gathered over some period of time by the Wireless Location System showing a reasonable consistency in the phase noise exhibited by various classes of transmitters. In these cases, the SCS 10 and/or the TLP 12 may be saved the processing step of determining the appropriate processing method.

10 A further enhancement of the present invention, used for both central based processing and station based processing, is the use of threshold criteria for including baselines in the final determination of location and velocity of the wireless transmitter. For each baseline, the Wireless Location System calculates a number of parameters that include: the SCS/antenna port used with the reference SCS/antenna in calculating the baseline, the peak, average, and variance in the power of the transmission as received at the SCS/antenna port used in the baseline and over the interval used for location processing, the correlation value from the cross-spectra correlation between the SCS/antenna used in the baseline and the reference SCS/antenna, the delay value for the baseline, the multipath mitigation parameters, the residual values remaining after the multipath mitigation calculations, the contribution of the SCS/antenna to the weighted GDOP in the final location solution, and a measure of the quality of fit of the baseline if included in the final location solution. Each baseline is included in the final location solution is each meets or exceeds the threshold criteria for each of the parameters described herein. A baseline may be excluded from the location solution if it fails to meet one or more of the threshold criteria. Therefore, it is frequently possible that the number of SCS/antennas actually used in the final location solution is less than the total number considered.

Previous Patent Numbers 5,327,144 and 5,608,410 disclosed a method by which the location processing minimized the least square difference (LSD) value of the following equation:

$$\text{LSD} = [Q_{12}(\text{Delay}_{T_{12}} - \text{Delay}_{O_{12}})^2 + Q_{13}(\text{Delay}_{T_{13}} - \text{Delay}_{O_{13}})^2 + \dots + Q_{xy}(\text{Delay}_{T_{xy}} - \text{Delay}_{O_{xy}})^2]$$

In the present implementation, this equation has been rearranged to the following form in order to make the location processing code more efficient:

$$\text{LSD} = \sum (TDOA_{0i} - \tau_i + \tau_0)^2 w_i^2; \text{ over all } i=1 \text{ to } N-1$$

where N = number of SCS/antennas used in the location processing;

10 TDOA<sub>0i</sub> = the TDOA to the i<sup>th</sup> site from reference site 0;

$\tau_i$  = the theoretical line of sight propagation time from the wireless transmitter to the i<sup>th</sup> site;

$\tau_0$  = the theoretical line of sight propagation time from the transmitter to the reference; and

$w_i$  = the weight, or quality factor, applied to the i<sup>th</sup> baseline.

15

In the present implementation, the Wireless Location System also uses another alternate form of the equation that can aid in determining location solutions when the reference signal is not very strong or when it is likely that a bias would exist in the location solution using the prior form of the equation:

20

$$\text{LSD}' = \sum (TDOA_{0i} - \tau_i)^2 w_i^2 - b^2 \sum w_i^2; \text{ over all } i=0 \text{ to } N-1$$

Where N = number of SCS/antennas used in the location processing;

TDOA<sub>0i</sub> = the TDOA to the i<sup>th</sup> site from reference site 0;

25 TDOA<sub>00</sub> = is assumed to be zero;

$\tau_i$  = the theoretical line of sight propagation time from the wireless transmitter to the i<sup>th</sup> site;

b = a bias that is separately calculated for each theoretical point that minimizes LSD' at that theoretical point; and

30  $w_i$  = the weight, or quality factor, applied to the i<sup>th</sup> baseline.

The LSD' form of the equation offers an easier means of removing a bias in location solutions at the reference site by making  $w_0$  equal to the maximum value of the other weights or basing  $w_0$  on the relative signal strength at the reference site. Note that if  $w_0$  is much larger than the other weights, then  $b$  is approximately equal to  $\tau_0$ . In general, the weights, or quality factors are based on similar criteria to that discussed above for the threshold criteria in including baselines. That is, the results of the criteria calculations are used for weights and when the criteria falls below threshold the weight is then set to zero and is effectively not included in the determination of the final location solution.

10 Antenna Selection Process for Location Processing

Previous inventions and disclosures, such as those listed above, have described techniques in which a first, second, or possibly third antenna site, cell site, or base station are required to determine location. Patent number 5,608,410 further discloses a Dynamic Selection Subsystem (DSS) that is responsible for determining which data frames from which antenna site locations will be used to calculate the location of a responsive transmitter. In the DSS, if data frames are received from more than a threshold number of sites, the DSS determines which are candidates for retention or exclusion, and then dynamically organizes data frames for location processing. The DSS prefers to use more than the minimum number of antenna sites so that the solution is over-determined. Additionally, the DSS assures that all transmissions used in the location processing were received from the same transmitter and from the same transmission.

The preferred embodiments of the prior inventions had several limitations, however. First, either only one antenna per antenna site (or cell site) is used, or the data from two or four diversity antennas were first combined at the antenna site (or cell site) prior to transmission to the central site. Additionally, all antenna sites that received the transmission sent data frames to the central site, even if the DSS later discarded the data frames. Thus, some communications bandwidth may have been wasted sending data that was not used.

30

The present inventors have determined that while a minimum of two or three sites are required in order determine location, the actual selection of antennas and SCS's 10 to use



in location processing can have a significant effect on the results of the location processing. In addition, it is advantageous to include the means to use more than one antenna at each SCS 10 in the location processing. The reason for using data from multiple antennas at a cell site independently in the location processing is that the signal received at each antenna is uniquely affected by multipath, fading, and other disturbances. It is well known in the field that when two antennas are separated in distance by more than one wavelength, then each antenna will receive the signal on an independent path. Therefore, there is frequently additional and unique information to be gained about the location of the wireless transmitter by using multiple antennas, and the ability of the Wireless Location System to mitigate multipath is enhanced accordingly.

It is therefore an object of the present invention to provide an improved method for using the signals received from more than one antenna at an SCS 10 in the location processing. It is a further object to provide a method to improve the dynamic process used to select the cooperating antennas and SCS's 10 used in the location processing. The first object is achieved by providing means within the SCS 10 to select and use any segment of data collected from any number of antennas at an SCS in the location processing. As described earlier, each antenna at a cell site is connected to a receiver internal to the SCS 10. Each receiver converts signals received from the antenna into a digital form, and then stores the digitized signals temporarily in a memory in the receiver. The TLP 12 has been provided with means to direct any SCS 10 to retrieve segments of data from the temporary memory of any receiver, and to provide the data for use in location processing. The second object is achieved by providing means within the Wireless Location System to monitor a large number of antennas for reception of the transmission that the Wireless Location System desires to locate, and then selecting a smaller set of antennas for use in location processing based upon a predetermined set of parameters. One example of this selection process is represented by the flowchart of Figure 8:

a wireless transmitter initiates a transmission on either a control channel or a voice channel (step S90);  
the transmission is received at multiple antennas and at multiple SCS's 10 in the Wireless Location System (step S91);

the transmission is converted into a digital format in the receiver connected to each antenna (step S92);  
the digital data is stored in a memory in each SCS 10 (step S93);  
the transmission is demodulated at at least one SCS 10A and the channel number on which the transmission occurred and the cell site and sector serving the wireless transmitter is determined (step S94);  
5 based upon the serving cell site and sector, one SCS 10A is designated as the 'primary' SCS 10 for processing that transmission (step S95);  
the primary SCS 10A determines a timestamp associated with the demodulated data (step S96);  
10 the Wireless Location System determines whether to begin location processing for the transmission (step S97);  
if location processing is triggered, the Wireless Location System determines a candidate list of SCS's 10 and antennas to use in the location processing (step S98);  
15 each candidate SCS/antenna measures and reports several parameters in the channel number of the transmission and at the time of the timestamp determined by the primary SCS 10A (step S99);  
the Wireless Location System orders the candidate SCS/antennas using specified criteria and selects a reference SCS/antenna and a processing list of SCS/antennas to use in the location processing (step S100); and  
20 the Wireless Location System proceeds with location processing as described earlier, using data from the processing list of SCS/antennas (step S101).

#### Selecting Primary SCS/Antenna

25 The process for choosing the 'primary' SCS/antenna is critical, because the candidate list of SCS's 10 and antennas 10-1 is determined in part based upon the designation of the primary SCS/antenna. When a wireless transmitter makes a transmission on a particular RF channel, the transmission frequently can propagate many miles before the signal attenuates below a level at which it can be demodulated. Therefore, there are frequently  
30 many SCS/antennas capable of demodulating the signal. This especially occurs in urban and suburban areas where the frequency re-use pattern of many wireless communications systems can be quite dense. For example, because of the high usage rate of wireless and

the dense cell site spacing, the present inventors have tested wireless communications systems in which the same RF control channel and digital color code were used on cell sites spaced about one mile apart. Because the Wireless Location System is independently demodulating these transmissions, the Wireless Location System frequently can

5 demodulate the same transmission at two, three, or more separate SCS/antennas. The Wireless Location System detects that the same transmission has been demodulated multiple times at multiple SCS/antennas when the Wireless Location System receives multiple demodulated data frames sent from different SCS/antennas, each with a number of bit errors below a predetermined bit error threshold, and with the demodulated data

10 matching within an acceptable limit of bit errors, and all occurring within a predetermined interval of time.

When the Wireless Location System detects demodulated data from multiple SCS/antennas, it examines the following parameters to determine which SCS/antenna shall

15 be designated the primary SCS: average SNR over the transmission interval used for location processing, the variance in the SNR over the same interval, correlation of the beginning of the received transmission against a pure pre-cursor (i.e. for AMPS, the dotting and Barker code), the number of bit errors in the demodulated data, and the magnitude and rate of change of the SNR from just before the on-set of the transmission to

20 the on-set of the transmission, as well as other similar parameters. The average SNR is typically determined at each SCS/antenna either over the entire length of the transmission to be used for location processing, or over a shorter interval. The average SNR over the shorter interval can be determined by performing a correlation with the dotting sequence and/or Barker code and/or sync word, depending on the particular air interface protocol,

25 and over a short range of time before, during, and after the timestamp reported by each SCS 10. The time range may typically be +/-200 microseconds centered at the timestamp, for example. The Wireless Location System will generally order the SCS/antennas using the following criteria, each of which may be weighted (multiplied by an appropriate factor) when combining the criteria to determine the final decision: SCS/antennas with a

30 lower number of bit errors are preferred to SCS/antennas with a higher number of bit errors, average SNR for a given SCS/antenna must be greater than a predetermined threshold to be designated as the primary; SCS/antennas with higher average SNR are

preferred over those with lower average SNR; SCS/antennas with lower SNR variance are preferred to those with higher SNR variance; and SCS/antennas with a faster SNR rate of change at the on-set of the transmission are preferred to those with a slower rate of change. The weighting applied to each of these criteria may be adjusted by the operator of the  
5 Wireless Location System to suit the particular design of each system.

The candidate list of SCS's 10 and antennas 10-1 are selected using a predetermined set of criteria based, for example, upon knowledge of the types of cell sites, types of antennas at the cell sites, geometry of the antennas, and a weighting factor that weights certain  
10 antennas more than other antennas. The weighting factor takes into account knowledge of the terrain in which the Wireless Location System is operating, past empirical data on the contribution of each antenna has made to good location estimates, and other factors that may be specific to each different WLS installation. In one embodiment, for example, the Wireless Location System may select the candidate list to include all SCS's 10 up to a  
15 maximum number of sites (`max_number_of_sites`) that are closer than a predefined maximum radius from the primary site (`max_radius_from_primary`). For example, in an urban or suburban environment, where there may be a large number of cell sites, the `max_number_of_sites` may be limited to nineteen. Nineteen sites would include the primary, the first ring of six sites surrounding the primary (assuming a classic hexagonal  
20 distribution of cell sites), and the next ring of twelve sites surrounding the first ring. This is depicted in Figure 9. In another embodiment, in a suburban or rural environment, `max_radius_from_primary` may be set to 40 miles to ensure that the widest possible set of candidate SCS/antennas is available. The Wireless Location System is provided with means to limit the total number of candidate SCS's 10 to a maximum number  
25 (`max_number_candidates`), although each candidate SCS may be permitted to choose the best port from among its available antennas. This limits the maximum time spent by the Wireless Location System processing a particular location. `Max_number_candidates` may be set to thirty-two, for example, which means that in a typical three sector wireless communications system with diversity, up to  $32 * 6 = 192$  total antennas could be  
30 considered for location processing for a particular transmission. In order to limit the time spent processing a particular location, the Wireless Location System is provided with means to limit the number of antennas used in the location processing to

max\_number\_antennas\_processed. Max\_number\_antennas\_processed is generally less than max\_number\_candidates, and is typically set to sixteen.

5 While the Wireless Location System is provided with the ability to dynamically determine the candidate list of SCS's 10 and antennas based upon the predetermined set of criteria described above, the Wireless Location System can also store a fixed candidate list in a table. Thus, for each cell site and sector in the wireless communications system, the Wireless Location System has a separate table that defines the candidate list of SCS's 10 and antennas 10-1 to use whenever a wireless transmitter initiates a transmission in that  
10 cell site and sector. Rather than dynamically choose the candidate SCS/antennas each time a location request is triggered, the Wireless Location System reads the candidate list directly from the table when location processing is initiated.

In general, a large number of candidate SCS's 10 is chosen to provide the Wireless  
15 Location System with sufficient opportunity and ability to measure and mitigate multipath. On any given transmission, any one or more particular antennas at one or more SCS's 10 may receive signals that have been affected to varying degrees by multipath. Therefore, it is advantageous to provide this means within the Wireless Location System to dynamically select a set of antennas which may have received less multipath than other  
20 antennas. The Wireless Location System uses various techniques to mitigate as much multipath as possible from any received signal; however it is frequently prudent to choose a set of antennas that contain the least amount of multipath.

#### Choosing Reference and Cooperating SCS/Antennas

25 In choosing the set of SCS/antennas to use in location processing, the Wireless Location System orders the candidate SCS/antennas using several criteria, including for example: average SNR over the transmission interval used for location processing, the variance in the SNR over the same interval, correlation of the beginning of the received transmission against a pure pre-cursor (i.e. for AMPS, the dotting and Barker code) and/or demodulated  
30 data from the primary SCS/antenna, the time of the on-set of the transmission relative to the on-set reported at the SCS/antenna at which the transmission was demodulated, and the magnitude and rate of change of the SNR from just before the on-set of the

transmission to the on-set of the transmission, as well as other similar parameters. The average SNR is typically determined at each SCS, and for each antenna in the candidate list either over the entire length of the transmission to be used for location processing, or over a shorter interval. The average SNR over the shorter interval can be determined by performing a correlation with the dotting sequence and/or Barker code and/or sync word, depending on the particular air interface protocol, and over a short range of time before, during, and after the timestamp reported by the primary SCS 10. The time range may typically be +/- 200 microseconds centered at the timestamp, for example. The Wireless Location System will generally order the candidate SCS/antennas using the following criteria, each of which may be weighted when combining the criteria to determine the final decision: average SNR for a given SCS/antenna must be greater than a predetermined threshold to be used in location processing; SCS/antennas with higher average SNR are preferred over those with lower average SNR; SCS/antennas with lower SNR variance are preferred to those with higher SNR variance; SCS/antennas with an on-set closer to the on-set reported by the demodulating SCS/antenna are preferred to those with an on-set more distant in time; SCS/antennas with a faster SNR rate of change are preferred to those with a slower rate of change; SCS/antennas with lower incremental weighted GDOP are preferred over those with higher incremental weighted GDOP, where the weighting is based upon estimated path loss from the primary SCS. The weighting applied to each of these preferences may be adjusted by the operator of the Wireless Location System to suit the particular design of each system. The number of different SCS's 10 used in the location processing is maximized up to a predetermined limit; the number of antennas used at each SCS 10 is limited to a predetermined limit; and the total number of SCS/antennas used is limited to max\_number\_antennas\_processed. The SCS/antenna with the highest ranking using the above described process is designated as the reference SCS/antenna for location processing.

#### Best Port Selection Within an SCS 10

Frequently, the SCS/antennas in the candidate list or in the list to use in location processing will include only one or two antennas at a particular SCS 10. In these cases, the Wireless Location System may permit the SCS 10 to choose the "best port" from all or some of the antennas at the particular SCS 10. For example, if the Wireless Location

System chooses to use only one antenna at a first SCS 10, then the first SCS 10 may select the best antenna port from the typical six antenna ports that are connected to that SCS 10, or it may choose the best antenna port from among the two antenna ports of just one sector of the cell site. The best antenna port is chosen by using the same process and comparing  
5 the same parameters as described above for choosing the set of SCS/antennas to use in location processing, except that all of the antennas being considered for best port are all in the same SCS 10. In comparing antennas for best port, the SCS 10 may also optionally divide the received signal into segments, and then measure the SNR separately in each segment of the received signal. Then, the SCS 10 can optionally choose the best antenna  
10 port with highest SNR either by (i) using the antenna port with the most segments with the highest SNR, (ii) averaging the SNR in all segments and using the antenna port with the highest average SNR, or (iii) using the antenna port with the highest SNR in any one segment.

15 Detection and Recovery From Collisions

Because the Wireless Location System will use data from many SCS/antenna ports in location processing, there is a chance that the received signal at one or more particular SCS/antenna ports contains energy that is co-channel interference from another wireless transmitter (i.e. a partial or full collision between two separate wireless transmissions has  
20 occurred). There is also a reasonable probability that the co-channel interference has a much higher SNR than the signal from the target wireless transmitter, and if not detected by the Wireless Location System, the co-channel interference may cause an incorrect choice of best antenna port at an SCS 10, reference SCS/antenna, candidate SCS/antenna, or SCS/antenna to be used in location processing. The co-channel interference may also  
25 cause poor TDOA and FDOA results, leading to a failed or poor location estimate. The probability of collision increases with the density of cell sites in the host wireless communications system, especially in dense suburban or rural environments where the frequencies are re-used often and wireless usage by subscribers is high.

30 Therefore, the Wireless Location System includes means to detect and recover from the types of collisions described above. For example, in the process of selecting a best port, reference SCS/antenna, or candidate SCS/antenna, the Wireless Location System

determines the average SNR of the received signal and the variance of the SNR over the interval of the transmission; when the variance of the SNR is above a predetermined threshold, the Wireless Location System assigns a probability that a collision has occurred. If the signal received at an SCS/antenna has increased or decreased its SNR in a single step, and by an amount greater than a predetermined threshold, the Wireless Location System assigns a probability that a collision has occurred. Further, if the average SNR of the signal received at a remote SCS is greater than the average SNR that would be predicted by a propagation model, given the cell site at which the wireless transmitter initiated its transmission and the known transmit power levels and antenna patterns of the transmitter and receive antennas, the Wireless Location System assigns a probability that a collision has occurred. If the probability that a collision has occurred is above a predetermined threshold, then the Wireless Location System performs the further processing described below to verify whether and to what extent a collision may have impaired the received signal at an SCS/antenna. The advantage of assigning probabilities is to reduce or eliminate extra processing for the majority of transmissions for which collisions have not occurred. It should be noted that the threshold levels, assigned probabilities, and other details of the collision detection and recovery processes described herein are configurable, i.e., selected based on the particular application, environment, system variables, etc., that would affect their selection.

For received transmissions at an SCS/antenna for which the probability of a collision is above the predetermined threshold and before using RF data from a particular antenna port in a reference SCS/antenna determination, best port determination or in location processing, the Wireless Location System preferably verifies that the RF data from each antenna port is from the correct wireless transmitter. This is determined, for example, by demodulating segments of the received signal to verify, for example, that the MIN, MSID, or other identifying information is correct or that the dialed digits or other message characteristics match those received by the SCS/antenna that initially demodulated the transmission. The Wireless Location System may also correlate a short segment of the received signal at an antenna port with the signal received at the primary SCS 10 to verify that the correlation result is above a predetermined threshold. If the Wireless Location System detects that the variance in the SNR over the entire length of the transmission is



above a pre-determined threshold, the Wireless Location System may divide the transmission into segments and test each segment as described herein to determine whether the energy in that segment is primarily from the signal from the wireless transmitter for which location processing has been selected or from an interfering transmitter.

The Wireless Location System may choose to use the RF data from a particular SCS/antenna in location processing even if the Wireless Location System has detected that a partial collision has occurred at that SCS/antenna. In these cases, the SCS 10 uses the means described above to identify that portion of the received transmission which represents a signal from the wireless transmitter for which location processing has been selected, and that portion of the received transmission which contains co-channel interference. The Wireless Location System may command the SCS 10 to send or use only selected segments of the received transmission that do not contain the co-channel interference. When determining the TDOA and FDOA for a baseline using only selected segments from an SCS/antenna, the Wireless Location System uses only the corresponding segments of the transmission as received at the reference SCS/antenna. The Wireless Location System may continue to use all segments for baselines in which no collisions were detected. In many cases, the Wireless Location System is able to complete location processing and achieve an acceptable location error using only a portion of the transmission. This inventive ability to select the appropriate subset of the received transmission and perform location processing on a segment by segment basis enables the Wireless Location System to successfully complete location processing in cases that might have failed using previous techniques.

25

#### Multiple Pass Location Processing

Certain applications may require a very fast estimate of the general location of a wireless transmitter, followed by a more accurate estimate of the location that can be sent subsequently. This can be valuable, for example, for E9-1-1 systems that handle wireless calls and must make a call routing decision very quickly, but can wait a little longer for a more exact location to be displayed upon the E9-1-1 call-taker's electronic map terminal.

30

The Wireless Location System supports these applications with an inventive multiple pass location processing mode.

In many cases, location accuracy is enhanced by using longer segments of the transmission and increasing the processing gain through longer integration intervals. But longer segments of the transmission require longer processing periods in the SCS 10 and TLP 12, as well as longer time periods for transmitting the RF data across the communications interface from the SCS 10 to the TLP 12. Therefore, the Wireless Location System includes means to identify those transmissions that require a fast but rough estimate of the location followed by more complete location processing that produces a better location estimate. The Signal of Interest Table includes a flag for each Signal of Interest that requires a multiple pass location approach. This flag specifies the maximum amount of time permitted by the requesting location application for the first estimate to be sent, as well as the maximum amount of time permitted by the requesting location application for the final location estimate to be sent. The Wireless Location System performs the rough location estimate by selecting a subset of the transmission for which to perform location processing. The Wireless Location System may choose, for example, the segment that was identified at the primary SCS/antenna with the highest average SNR. After the rough location estimate has been determined, using the methods described earlier, but with only a subset of the transmission, the TLP 12 forwards the location estimate to the AP 14, which then forwards the rough estimate to the requesting application with a flag indicating that the estimate is only rough. The Wireless Location System then performs its standard location processing using all of the aforementioned methods, and forwards this location estimate with a flag indicating the final status of this location estimate. The Wireless Location System may perform the rough location estimate and the final location estimate sequentially on the same DSP in a TLP 12, or may perform the location processing in parallel on different DSP's. Parallel processing may be necessary to meet the maximum time requirements of the requesting location applications. The Wireless Location System supports different maximum time requirements from different location applications for the same wireless transmission.

### Very Short Baseline TDOA

The Wireless Location System is designed to operate in urban, suburban, and rural areas. In rural areas, when there are not sufficient cell sites available from a single wireless carrier, the Wireless Location System can be deployed with SCS's 10 located at the cell sites of other wireless carriers or at other types of towers, including AM or FM radio station, paging, and two-way wireless towers. In these cases, rather than sharing the existing antennas of the wireless carrier, the Wireless Location System may require the installation of appropriate antennas, filters, and low noise amplifiers to match the frequency band of the wireless transmitters of interest to be located. For example, an AM radio station tower may require the addition of 800 MHz antennas to locate cellular band transmitters. There may be cases, however, where no additional towers of any type are available at reasonable cost and the Wireless Location System must be deployed on just a few towers of the wireless carrier. In these cases, the Wireless Location System supports an antenna mode known as very short baseline TDOA. This antenna mode becomes active when additional antennas are installed on a single cell site tower, whereby the antennas are placed at a distance of less than one wavelength apart. This may require the addition of just one antenna per cell site sector such that the Wireless Location System uses one existing receive antenna in a sector and one additional antenna that has been placed next to the existing receive antenna. Typically, the two antennas in the sector are oriented such that the primary axes, or line of direction, of the main beams are parallel and the spacing between the two antenna elements is known with precision. In addition, the two RF paths from the antenna elements to the receivers in the SCS 10 are calibrated.

In its normal mode, the Wireless Location System determines the TDOA and FDOA for pairs of antenna that are separated by many wavelengths. For a TDOA on a baseline using antennas from two different cell sites, the pairs of antennas are separated by thousands of wavelengths. For a TDOA on a baseline using antennas at the same cell site, the pairs of antennas are separated by tens of wavelengths. In either case, the TDOA determination effectively results in a hyperbolic line bisecting the baseline and passing through the location of the wireless transmitter. When antennas are separated by multiple wavelengths, the received signal has taken independent paths from the wireless transmitter to each antenna, including experiencing different multipath and Doppler shifts. However, when

two antennas are closer than one wavelength, the two received signals have taken essentially the same path and experienced the same fading, multipath, and Doppler shift. Therefore, the TDOA and FDOA processing of the Wireless Location System typically produces a Doppler shift of zero (or near-zero) hertz, and a time difference on the order of  
5 zero to one nanosecond. A time difference that short is equivalent to an unambiguous phase difference between the signals received at the two antennas on the very short baseline. For example, at 834 MHz, the wavelength of an AMPS reverse control channel transmission is about 1.18 feet. A time difference of 0.1 nanoseconds is equivalent to a received phase difference of about 30 degrees. In this case, the TDOA measurement  
10 produces a hyperbola that is essentially a straight line, still passing through the location of the wireless transmitter, and in a direction that is rotated 30 degrees from the direction of the parallel lines formed by the two antennas on the very short baseline. When the results of this very short baseline TDOA at the single cell site are combined with a TDOA measurement on a baseline between two cell sites, the Wireless Location System can  
15 determine a location estimate using only two cell sites.

#### Bandwidth Monitoring Method For Improving Location Accuracy

AMPS cellular transmitters presently comprise the large majority of the wireless transmitters used in the U.S. and AMPS reverse voice channel transmissions are generally  
20 FM signals modulated by both voice and a supervisory audio tone (SAT). The voice modulation is standard FM, and is directly proportional to the speaking voice of the person using the wireless transmitter. In a typical conversation, each person speaks less than 35% of the time, which means that most of the time the reverse voice channel is not being modulated due to voice. With or without voice, the reverse channel is continuously  
25 modulated by SAT, which is used by the wireless communications system to monitor channel status. The SAT modulation rate is only about 6 KHz. The voice channels support in-band messages that are used for hand-off control and for other reasons, such as for establishing a 3-way call, for answering a second incoming call while already on a first call, or for responding to an 'audit' message from the wireless communications system.  
30 All of these messages, though carried on the voice channel, have characteristics similar to the control channel messages. These messages are transmitted infrequently, and location

systems have ignored these messages and focused on the more prevalent SAT transmissions as the signal of interest.

5 In view of the above-described difficulties presented by the limited bandwidth of the FM voice and SAT reverse voice channel signals, an object of the present invention is to provide an improved method by which reverse voice channel (RVC) signals may be utilized to locate a wireless transmitter, particularly in an emergency situation. Another object of the invention is to provide a location method that allows the location system to avoid making location estimates using RVC signals in situations in which it is likely that  
10 the measurement will not meet prescribed accuracy and reliability requirements. This saves system resources and improves the location system's overall efficiency. The improved method is based upon two techniques. Figure 10A is a flowchart of a first method in accordance with the present invention for measuring location using reverse voice channel signals. The method comprises the following steps:

15

(i) It is first assumed that a user with a wireless transmitter wishes to be located, or wishes to have his location updated or improved upon. This may be the case, for example, if the wireless user has dialed "911" and is seeking emergency assistance. It is therefore also assumed that the user is coherent and in communication with a centrally located dispatcher.  
20

(ii) When the dispatcher desires a location update for a particular wireless transmitter, the dispatcher sends a location update command with the identity of the wireless transmitter to the Wireless Location System over an application interface.

(iii) The Wireless Location System responds to the dispatcher with a confirmation that  
25 the Wireless Location System has queried the wireless communications system and has obtained the voice channel assignment for the wireless transmitter.

(iv) The dispatcher instructs the wireless user to dial a 9 or more digit number and then the "SEND" button. This sequence may be something like "123456789" or "911911911". Two functions happen to the reverse voice channel when the  
30 wireless user dial a sequence of at least 9 digits and then the "SEND" button. First, especially for an AMPS cellular voice channel, the dialing of digits causes the sending of dual tone multi-frequency (DTMF) tones over the voice channel. The

modulation index of DTMF tones is very high and during the sending of each digit in the DTMF sequence will typically push the bandwidth of the transmitted signal beyond +/- 10 KHz. The second function occurs at the pressing of the "SEND" button. Whether or not the wireless user subscribes to 3-way calling or other special features, the wireless transmitter will send a message over the voice using a "blank and burst" mode where the transmitter briefly stops sending the FM voice and SAT, and instead sends a bursty message modulated in the same manner as the control channel (10 Kbits Manchester). If the wireless user dials less than 9 digits, the message will be comprised of approximately 544 bits. If the wireless user dials 9 or more digits, the message is comprised of approximately 987 bits.

(v) After notification by the dispatcher, the Wireless Location System monitors the bandwidth of the transmitted signal in the voice channel. As discussed earlier, when only the SAT is being transmitted, and even if voice and SAT are being transmitted, there may not be sufficient bandwidth in the transmitted signal to calculate a high quality location estimate. Therefore, the Wireless Location System conserves location processing resources and waits until the transmitted signal exceeds a predetermined bandwidth. This may be, for example, set somewhere in the range of 8 KHz to 12 KHz. When the DTMF dialed digits are sent or when the bursty message is sent, the bandwidth would typically exceed the predetermined bandwidth. In fact, if the wireless transmitter does transmit the DTMF tones during dialing, the bandwidth would be expected to exceed the predetermined bandwidth multiple times. This would provide multiple opportunities to perform a location estimate. If the DTMF tones are not sent during dialing, the bursty message is still sent at the time of pressing "SEND", and the bandwidth would typically exceed the predetermined threshold.

(vi) Only when the transmitted bandwidth of the signal exceeds the predetermined bandwidth, the Wireless Location System initiates location processing.

Figure 10B is a flowchart of another method in accordance with the present invention for measuring location using reverse voice channel signals. The method comprises the following steps:

- 5 (i) It is first assumed that a user with a wireless transmitter wishes to be located, or wishes to have their location updated or improved upon. This may be the case, for example, if the wireless user has dialed "911" and is seeking emergency assistance. It is assumed that the user may not wish to dial digits or may not be able to dial any digits in accordance with the previous method.
- (ii) When the dispatcher desires a location update for a particular wireless transmitter user, the dispatcher sends a location update command to the Wireless Location System over an application interface with the identity of the wireless transmitter.
- (iii) The Wireless Location System responds to the dispatcher with a confirmation.
- 10 (iv) The Wireless Location System commands the wireless communications system to make the wireless transmitter transmit by sending an "audit" or similar message to the wireless transmitter. The audit message is a mechanism by which the wireless communications system can obtain a response from the wireless transmitter without requiring an action by the end-user and without causing the wireless
- 15 transmitter to ring or otherwise alert. The receipt of an audit message causes the wireless transmitter to respond with an "audit response" message on the voice channel.
- (v) After notification by the dispatcher, the Wireless Location System monitors the bandwidth of the transmitted signal in the voice channel. As discussed earlier,
- 20 when only the SAT is being transmitted, and even if voice and SAT are being transmitted, there may not be sufficient bandwidth in the transmitted signal to calculate a high quality location estimate. Therefore, the radio location conserves location processing resources and waits until the transmitted signal exceeds a predetermined bandwidth. This may be, for example, set somewhere in the range
- 25 of 8 KHz to 12 KHz. When the audit response message is sent, the bandwidth would typically exceed the predetermined bandwidth.
- (vi) Only when the transmitted bandwidth of the signal exceeds the predetermined bandwidth, the Wireless Location System initiates location processing.

30 Estimate Combination Method For Improving Location Accuracy

The accuracy of the location estimate provided by the Wireless Location System may be improved by combining multiple statistically-independent location estimates made while

the wireless transmitter is maintaining its position. Even when a wireless transmitter is perfectly stationary, the physical and RF environment around a wireless transmitter is constantly changing. For example, vehicles may change their position or another wireless transmitter which had caused a collision during one location estimate may have stopped transmitting or changed its position so as to no longer collide during subsequent location estimates. The location estimate provided by the Wireless Location System will therefore change for each transmission, even if consecutive transmissions are made within a very short period of time, and each location estimate is statistically independent of the other estimates, particularly with respect to the errors caused by the changing environment.

10

When several consecutive statistically independent location estimates are made for a wireless transmitter that has not changed its position, the location estimates will tend to cluster about the true position. The Wireless Location System combines the location estimates using a weighted average or other similar mathematical construct to determine the improved estimate. The use of a weighted average is aided by the assignment of a quality factor to each independent location estimate. This quality factor may be based upon, for example, the correlation values, confidence interval, or other similar measurements derived from the location processing for each independent estimate. The Wireless Location System optionally uses several methods to obtain multiple independent transmissions from the wireless transmitter, including (i) using its interface to the wireless communications system for the Make Transmit command; (ii) using multiple consecutive bursts from a time slot based air interface protocol, such as TDMA or GSM; or (iii) dividing a voice channel transmission into multiple segments over a period of time and performing location processing independently for each segment. As the Wireless Location System increases the number of independent location estimates being combined into the final location estimate, it monitors a statistic indicating the quality of the cluster. If the statistic is below a prescribed threshold value, then the Wireless Location System assumes that the wireless transmitter is maintaining its position. If the statistic rises above the prescribed threshold value, the Wireless Location System assume that the wireless transmitter is not maintaining its position and therefore ceases to perform additional location estimates. The statistic indicating the quality of the cluster may be, for example, a standard deviation calculation or a root mean square (RMS) calculation for the individual

25  
30



location estimates being combined together and with respect to the dynamically calculated combined location estimate. When reporting a location record to a requesting application, the Wireless Location System indicates, using a field in the location record, the number of independent location estimate combined together to produce the reported location  
5 estimate.

Another exemplary process for obtaining and combining multiple location estimates will now be explained with reference to Figures 11A-11D. Figures 11A, 11B and 11C schematically depict the well-known "origination", "page response," and "audit" sequences  
10 of a wireless communications system. As shown in Figure 11A, the origination sequence (initiated by the wireless phone to make a call) may require two transmissions from the wireless transmitter, an "originate" signal and an "order confirmation" signal. The order confirmation signal is sent in response to a voice channel assignment from the wireless communications system (e.g., MSC). Similarly, as shown in Figure 11B, a page sequence  
15 may involve two transmissions from the wireless transmitter. The page sequence is initiated by the wireless communications system, e.g., when the wireless transmitter is called by another phone. After being paged, the wireless transmitter transmits a page response; and then, after being assigned a voice channel, the wireless transmitter transmits an order confirmation signal. The audit process, in contrast, elicits a single reverse  
20 transmission, an audit response signal. An audit and audit response sequence has the benefit of not ringing the wireless transmitter which is responding.

The manner in which these sequences may be used to locate a phone with improved accuracy will now be explained. According to the present invention, for example, a stolen  
25 phone, or a phone with a stolen serial number, is repeatedly pinged with an audit signal, which forces it to respond with multiple audit responses, thus permitting the phone to be located with greater accuracy. To use the audit sequence, however, the Wireless Location System sends the appropriate commands using its interface to the wireless communications system, which sends the audit message to the wireless transmitter. The  
30 Wireless Location System can also force a call termination (hang up) and then call the wireless transmitter back using the standard ANI code. The call can be terminated either by verbally instructing the mobile user to disconnect the call, by disconnecting the call at

the landline end of the call, or by sending an artificial over-the-air disconnect message to the base station. This over-the-air disconnect message simulates the pressing of the "END" button on a mobile unit. The call-back invokes the above-described paging sequence and forces the phone to initiate two transmissions that can be utilized to make location  
5 estimates.

Referring now to Figure 11D, the inventive high accuracy location method will now be summarized. First, an initial location estimate is made. Next, the above-described audit or "hang up and call back" process is employed to elicit a responsive transmission from the  
10 mobile unit, and then a second location estimate is made. Whether the audit or "hang up and call back" process is used will depend on whether the wireless communications system and wireless transmitter have both implemented the audit functionality. Steps second and third steps are repeated to obtain however many independent location estimates are deemed to be necessary or desirable, and ultimately the multiple statistically-  
15 independent location estimates are combined in an average, weighted average, or similar mathematical construct to obtain an improved estimate. The use of a weighted average is aided by the assignment of a quality factor to each independent location estimate. This quality factor may be based upon a correlation percentage, confidence interval, or other similar measurements derived from the location calculation process.

20

#### Bandwidth Synthesis Method For Improving Location Accuracy

The Wireless Location System is further capable of improving the accuracy of location estimates for wireless transmitters whose bandwidth is relatively narrow using a technique of artificial bandwidth synthesis. This technique can applied, for example, to those  
25 transmitters that use the AMPS, NAMPS, TDMA, and GSM air interface protocols and for which there are a large number of individual RF channels available for use by the wireless transmitter. For exemplary purposes, the following description shall refer to AMPS-specific details; however, the description can be easily altered to apply to other protocols. This method relies on the principle that each wireless transmitter is operative to transmit  
30 only narrowband signals at frequencies spanning a predefined wide band of frequencies that is wider than the bandwidth of the individual narrowband signals transmitted by the wireless transmitter. This method also relies on the aforementioned interface between the

Wireless Location System and the wireless communications system over which the WLS can command the wireless communications system to make a wireless transmitter handoff or switch to another frequency or RF channel. By issuing a series of commands, the Wireless Location System can force the wireless transmitter to switch sequentially and in a controlled manner to a series of RF channels, allowing the WLS effectively to synthesize a wider band received signal from the series of narrowband transmitted signals for the purpose of location processing.

In a presently preferred embodiment of the invention, the bandwidth synthesis means includes means for determining a wideband phase versus frequency characteristic of the transmissions from the wireless transmitter. For example, the narrowband signals typically have a bandwidth of approximately 20 KHz and the predefined wide band of frequencies spans approximately 12.5 MHz, which in this example, is the spectrum allocated to each cellular carrier by the FCC. With bandwidth synthesis, the resolution of the TDOA measurements can be increased to about  $1/12.5$  MHz; i.e., the available time resolution is the reciprocal of the effective bandwidth.

A wireless transmitter, a calibration transmitter (if used), SCS's 10A, 10B and 10C, and a TLP 12 are shown in Figure 12A. The location of the calibration transmitter and all three SCS's are accurately known *a priori*. Signals, represented by dashed arrows in Figure 12A, are transmitted by the wireless transmitter and calibration transmitter, and received at SCS's 10A, 10B and 10C, and processed using techniques previously described. During the location processing, RF data from one SCS (e.g. 10B) is cross-correlated (in the time or frequency domain) with the data stream from another SCS (e.g. 10C) separately for each transmitter and for each pair of SCS's 10 to generate TDOA estimates  $TDOA_{23}$  and  $TDOA_{13}$ . An intermediate output of the location processing is a set of coefficients representing the complex cross-power as a function of frequency (e.g.,  $R_{23}$ ).

For example, if  $X(f)$  is the Fourier transform of the signal  $x(t)$  received at a first site and  $Y(f)$  is the Fourier transform of the signal  $y(t)$  received at a second site, then the complex cross-power  $R(f)=X(f)Y^*(f)$ , where  $Y^*$  is the complex conjugate of  $Y$ . The phase angle of  $R(f)$  at any frequency  $f$  equals the phase of  $X(f)$  minus the phase of  $Y(f)$ . The phase angle

of  $R(f)$  may be called the fringe phase. In the absence of noise, interference, and other errors, the fringe phase is a perfectly linear function of frequency within a (contiguous) frequency band observed; and slope of the line is minus the interferometric group delay, or TDOA; the intercept of the line at the band center frequency, equal to the average value of the phase of  $R(f)$ , is called "the" fringe phase of the observation when reference is being made to the whole band. Within a band, the fringe phase may be considered to be a function of frequency.

The coefficients obtained for the calibration transmitter are combined with those obtained for the wireless transmitter and the combinations are analyzed to obtain calibrated TDOA measurements  $TDOA_{23}$  and  $TDOA_{13}$ , respectively. In the calibration process, the fringe phase of the calibration transmitter is subtracted from the fringe phase of the wireless transmitter in order to cancel systematic errors that are common to both. Since each original fringe phase is itself the difference between the phases of signals received at two SCS's 10, the calibration process is often called *double-differencing* and the calibrated result is said to be *doubly-differenced*. TDOA estimate  $T_{ij}$  is a maximum-likelihood estimate of the time difference of arrival (TDOA), between sites  $i$  and  $j$ , of the signal transmitted by the wireless transmitter, calibrated and also corrected for multipath propagation effects on the signals. TDOA estimates from different pairs of cell sites are combined to derive the location estimate. It is well known that more accurate TDOA estimates can be obtained by observing a wider bandwidth. It is generally not possible to increase the "instantaneous" bandwidth of the signal transmitted by a wireless transmitter, but it is possible to command a wireless transmitter to switch from one frequency channel to another so that, in a short time, a wide bandwidth can be observed.

In a typical non-wireline cellular system, for example, channels 313-333 are control channels and the remaining 395 channels are voice channels. The center frequency of a wireless transmitter transmitting on voice RF channel number 1 (RVC 1) is 826.030 MHz and the center-to-center frequency spacing of successive channels of 0.030 MHz. The number of voice channels assigned to each cell of a typical seven-cell frequency-reuse block is about 57 (i.e., 395 divided by 7) and these channels are distributed throughout the 395-channel range, spaced every 7 channels. Note then that each cell site used in an

AMPS system has channels that span the entire 12.5 MHz band allocated by the FCC. If, for example, we designate cells of each frequency set in a re-use pattern as cells "A" through "G", the channel numbers assigned to the "A" cell(s) might be 1, 8, 15, 22, ..., 309; the numbers of the channels assigned to the "B" cells are determined by adding 1 to the "A" channel numbers; and so on through G.

The method begins when the wireless transmitter has been assigned to a voice RF channel, and the Wireless Location System has triggered location processing for the transmissions from the wireless transmitter. As part of the location processing, the TDOA estimates TDOA<sub>13</sub> and TDOA<sub>23</sub> combined may have, for example, a standard deviation error of 0.5 microsecond. The method combining measurements from different RF channels exploits the relation between TDOA, fringe phase, and radio frequency. Denote the "true" value of the group delay or TDOA, i.e., the value that would be observed in the absence of noise, multipath, and any instrumental error, by  $\tau$ ; similarly, denote the true value of fringe phase by  $\phi$ ; and denote the radio frequency by  $f$ . The fringe phase  $\phi$  is related to  $\tau$  and  $f$  by:

$$\phi = -f\tau + n \quad (\text{Eq. 1})$$

where  $\phi$  is measured in cycles,  $f$  in Hz and  $\tau$  in seconds; and  $n$  is an integer representing the intrinsic integer-cycle ambiguity of a doubly-differenced phase measurement. The value of  $n$  is unknown *a priori* but is the same for observations at contiguous frequencies, i.e., within any one frequency channel. The value of  $n$  is generally different for observations at separated frequencies.  $\tau$  can be estimated from observations in a single frequency channel is, in effect, by fitting a straight line to the fringe phase observed as a function of frequency within the channel. The slope of the best-fitting line equals minus the desired estimate of  $\tau$ . In the single-channel case,  $n$  is constant and so Eq. 1 can be differentiated to obtain:

$$d\phi/df = -\tau \quad (\text{Eq. 2}).$$

Independent estimates of  $\tau$  are obtainable by straight-line fitting to the observations of  $\phi$  vs.  $f$  separately for each channel, but when two separate (non-contiguous) frequency channels are observed, a single straight line will not generally fit the observations of  $\phi$  vs.  $f$  from both channels because, in general, the integer  $n$  has different values for the two channels. However, under certain conditions, it is possible to determine and remove the difference between these two integer values and then to fit a single straight line to the entire set of phase data spanning both channels. The slope of this straight line will be much better determined because it is based on a wider range of frequencies. Under certain conditions, the uncertainty of the slope estimate is inversely proportional to the frequency span.

In this example, suppose that the wireless transmitter has been assigned to voice RF channel 1. The radio frequency difference between channels 1 and 416 is so great that initially the difference between the integers  $n_1$  and  $n_{416}$  corresponding to these channels cannot be determined. However, from the observations in either or both channels taken separately, an initial TDOA estimate  $\tau_0$  can be derived. Now the Wireless Location System commands the wireless communications system to make the wireless transmitter to switch from channel 1 to channel 8. The wireless transmitter's signal is received in channel 8 and processed to update or refine the estimate  $\tau_0$ . From  $\tau_0$ , the "theoretical" fringe-phase  $\phi_0$  as a function of frequency can be computed, equal to  $(-f\tau_0)$ . The difference between the actually observed phase  $\phi$  and the theoretical function  $\phi_0$  can be computed, where the actually observed phase equals the true phase within a very small fraction, typically 1/50th, of a cycle:

$$\phi - \phi_0 = -f(\tau - \tau_0) + n_1 \text{ or } n_8, \text{ depending on the channel} \quad (\text{Eq. 3})$$

or

$$\Delta\phi = -\Delta f\tau - n_1 \text{ or } n_8, \text{ depending on the channel} \quad (\text{Eq. 4})$$

where  $\Delta\phi \equiv \phi - \phi_0$  and  $\Delta\tau \equiv \tau - \tau_0$ . Equation (4) is graphed in Figure 12B, depicting the difference,  $\Delta\phi$ , between the observed fringe phase  $\phi$  and the value  $\phi_0$  computed from the initial TDOA estimate  $\tau_0$ , versus frequency  $f$  for channels 1 and 8.

For the 20 KHz-wide band of frequencies corresponding to channel 1, a graph of  $\Delta\phi$  vs.  $f$  is typically a horizontal straight line. For the 20 KHz-wide band of frequencies corresponding to channel 8, the graph of  $\Delta\phi$  vs.  $f$  is also horizontal straight line. The slopes of these line segments are generally nearly zero because the quantity ( $f\Delta\tau$ ) usually does not vary by a significant fraction of a cycle within 20 KHz, because  $\Delta\tau$  is minus the error of the estimate  $\tau_0$ . The magnitude of this error typically will not exceed 1.5 microseconds (3 times the standard deviation of 0.5 microseconds in this example), and the product of 1.5 microseconds and 20 KHz is under 4% of a cycle. In Figure 12B, the graph of  $\Delta\phi$  for channel 1 is displaced vertically from the graph of  $\Delta\phi$  for channel 8 by a relatively large amount because the difference between  $n_1$  and  $n_8$  can be arbitrarily large. This vertical displacement, or difference between the average values of  $\Delta\phi$  for channels 1 and 8, will (with extremely high probability) be within  $\pm 0.3$  cycle of the true value of the difference,  $n_1$  and  $n_8$ , because the product of the maximum likely magnitude of  $\Delta\tau$  (1.5 microseconds) and the spacing of channels 1 and 8 (210 KHz) is 0.315 cycle. In other words, the difference  $n_1 - n_8$  is equal to the difference between the average values of  $\Delta\phi$  for channels 1 and 8, rounded to the nearest integer. After the integer difference  $n_1 - n_8$  is determined by this rounding procedure, the integer  $\Delta\phi$  is added for channel 8 or subtracted from  $\Delta\phi$  for channel 1. The difference between the average values of  $\Delta\phi$  for channels 1 and 8 is generally equal to the error in the initial TDOA estimate,  $\tau_0$ , times 210 KHz. The difference between the average values of  $\Delta\phi$  for channels 1 and 8 is divided by 210 KHz and the result is added to  $\tau_0$  to obtain an estimate of  $\tau$ , the true value of the TDOA; this new estimate can be significantly more accurate than  $\tau_0$ .

This frequency-stepping and TDOA-refining method can be extended to more widely spaced channels to obtain yet more accurate results. If  $\tau_1$  is used to represent the refined result obtained from channels 1 and 8,  $\tau_0$  can be replaced by  $\tau_1$  in the just-described method; and the Wireless Location System can command the wireless communications system to make the wireless transmitter switch, e.g., from channel 8 to channel 36; then  $\tau_1$  can be used to determine the integer difference  $n_8 - n_{36}$  and a TDOA estimate can be obtained based on the 1.05 MHz frequency span between channels 1 and 36. The

estimated can be labeled  $\tau_2$ ; and the wireless transmitter switched, e.g., from channel 36 to 112, and so on. In principle, the full range of frequencies allocated to the cellular carrier can be spanned. The channel numbers (1, 8, 36, 112) used in this example are, of course, arbitrary. The general principle is that an estimate of the TDOA based on a small  
5 frequency span (starting with a single channel) is used to resolve the integer ambiguity of the fringe phase difference between more widely separated frequencies. The latter frequency separation should not be too large; it is limited by the uncertainty of the prior estimate of TDOA. In general, the worst-case error in the prior estimate multiplied by the frequency difference may not exceed 0.5 cycle.

10

If the very smallest (e.g., 210 KHz) frequency gap between the most closely spaced channels allocated to a particular cell cannot be bridged because the worst-case uncertainty of the single-channel TDOA estimate exceeds 2.38 microseconds (equal to 0.5 cycle divided by 0.210 MHz), the Wireless Location System commands the wireless  
15 communications system to force the wireless transmitter hand-off from one cell site to another (e.g. from one frequency group to another), such that the frequency step is smaller. There is a possibility of misidentifying the integer difference between the phase differences ( $\Delta\phi$ 's) for two channels, e.g., because the wireless transmitter moved during the handoff from one channel to the other. Therefore, as a check, the Wireless Location  
20 System may reverse each handoff (e.g., after switching from channel 1 to channel 8, switch from channel 8 back to channel 1) and confirm that the integer-cycle difference determined has precisely the same magnitude and the opposite sign as for the "forward" hand-off. A significantly nonzero velocity estimate from the single-channel FDOA observations can be used to extrapolate across the time interval involved in a channel  
25 change. Ordinarily this time interval can be held to a small fraction of 1 second. The FDOA estimation error multiplied by the time interval between channels must be small in comparison with 0.5 cycle. The Wireless Location System preferably employs a variety of redundancies and checks against integer-misidentification.

### 30 Directed Retry for 911

Another inventive aspect of the Wireless Location System relates to a "directed retry" method for use in connection with a dual-mode wireless communications



system supporting at least a first modulation method and a second modulation method. In such a situation, the first and second modulation methods are assumed to be used on different RF channels (i.e. channels for the wireless communications system supporting a WLS and the PCS system, respectively). It is also assumed that  
5 the wireless transmitter to be located is capable of supporting both modulation methods, i.e. is capable of dialing "911" on the wireless communications system having Wireless Location System support.

For example, the directed retry method could be used in a system in which there are  
10 an insufficient number of base stations to support a Wireless Location System, but which is operating in a region served by a Wireless Location System associated with another wireless communications system. The "first" wireless communications system could be a cellular telephone system and the "second" wireless  
15 communications system could be a PCS system operating within the same territory as the first system. According to the invention, when the mobile transmitter is currently using the second (PCS) modulation method and attempts to originate a call to 911, the mobile transmitter is caused to switch automatically to the first  
20 modulation method, and then to originate the call to 911 using the first modulation method on one of the set of RF channels prescribed for use by the first wireless communications system. In this manner, location services can be provided to customers of a PCS or like system that does is not served by its own Wireless Location System.

#### Conclusion

25 The true scope the present invention is not limited to the presently preferred embodiments disclosed herein. For example, the foregoing disclosure of a presently preferred embodiment of a Wireless Location System uses explanatory terms, such as Signal Collection System (SCS), TDOA Location Processor (TLP), Applications Processor (AP), and the like, which should not be construed so as to limit the scope of protection of the  
30 following claims, or to otherwise imply that the inventive aspects of the Wireless Location System are limited to the particular methods and apparatus disclosed. Moreover, as will be understood by those skilled in the art, many of the inventive aspects disclosed herein may

be applied in location systems that are not based on TDOA techniques. For example, the processes by which the Wireless Location System uses the Tasking List, etc. can be applied to non-TDOA systems. In such non-TDOA systems, the TLP's described above would not be required to perform TDOA calculations. Similarly, the invention is not

5 limited to systems employing SCS's constructed as described above, nor to systems employing AP's meeting all of the particulars described above. The SCS's, TLP's and AP's are, in essence, programmable data collection and processing devices that could take a variety of forms without departing from the inventive concepts disclosed herein. Given the

10 rapidly declining cost of digital signal processing and other processing functions, it is easily possible, for example, to transfer the processing for a particular function from one of the functional elements (such as the TLP) described herein to another functional element (such as the SCS or AP) without changing the inventive operation of the system. In many cases, the place of implementation (i.e. the functional element) described herein is merely a designer's preference and not a hard requirement. Accordingly, except as they

15 may be expressly so limited, the scope of protection of the following claims is not intended to be limited to the specific embodiments described above.

**CLAIMS**

What is claimed is:

1. A method for use in a Wireless Location System in locating a mobile transmitter, comprising the steps of:
  - 5 (a) monitoring the bandwidth of a reverse voice channel (RVC) signal;
  - (b) determining whether said bandwidth exceeds a predetermined threshold; and
  - (c) calculating the location of said mobile transmitter if and only if said bandwidth exceeds said predetermined threshold.
- 10 2. A method as recited in claim 1, wherein said mobile transmitter is carried by a user, the method further comprises the step of, prior to step (c) and after determining in step (b) that said bandwidth does not exceed said threshold, taking an action to cause the mobile transmitter to transmit an RVC signal with a larger bandwidth.
- 15 3. A method as recited in claim 2, further comprising asking said user to dial a number of at least 9 digits.
4. A method as recited in claim 2, further comprising asking an emergency dispatcher to instruct said user to dial a number of at least 9 digits.
- 20 5. A method as recited in claim 1, wherein said predetermined threshold is within the range of approximately 8 to 12 KHz.
6. A method as recited in claim 5, wherein said predetermined threshold is approximately  
25 10 KHz.
7. A method as recited in claim 5, wherein said mobile transmitter is carried by a user and the method further comprises the step of, prior to step (c) and after determining in step (b) that said bandwidth does not exceed said threshold, taking an action to cause the mobile  
30 transmitter to transmit an RVC signal of increased bandwidth.

8. A method as recited in claim 2, wherein the method further comprises sending an audit message to the mobile transmitter.
9. A method as recited in claim 8, wherein the audit message is sent automatically to the mobile transmitter upon command from the wireless location system.
10. A method for use in a Wireless Location System in locating a mobile transmitter in an emergency situation, comprising the steps of:
- (a) upon determining that said emergency situation exists, monitoring a bandwidth of a reverse voice channel (RVC) signal transmitted by said mobile transmitter;
  - (b) determining whether said bandwidth exceeds a predetermined threshold;
  - (c) if said bandwidth exceeds said predetermined threshold, measuring the location of said mobile transmitter; and
  - (d) if said bandwidth does not exceed said predetermined threshold, performing a predetermined action to increase said bandwidth and subsequently measuring the location of said mobile transmitter.
11. A method as recited in claim 10, wherein said mobile transmitter is carried by a user and said predetermined action comprises requesting the user to take an action to cause the mobile transmitter to transmit an RVC signal comprising a prescribed number of bits.
12. A method as recited in claim 11, wherein said predetermined action comprises asking said user to a number of at least 9 digits.
13. A method as recited in claim 11, wherein said predetermined action comprises asking an emergency dispatcher to instruct said user to dial a number of at least 9 digits.
14. A method as recited in claim 10, wherein said predetermined threshold is within the range of approximately 8 to 12 KHz.
15. A method as recited in claim 14, wherein said predetermined threshold is approximately 10 KHz.

16. A method as recited in claim 12, wherein said mobile transmitter is carried by a user and said predetermined action comprises requesting the user to take an action to cause the mobile transmitter to transmit an RVC signal comprising a prescribed number of bits.
- 5
17. A method as recited in claim 16, wherein said predetermined action comprises asking said user to dial a 9-digit number.
18. A method as recited in claim 16, wherein said predetermined action comprises asking  
10 an emergency dispatcher to instruct said user to dial a 9-digit number.
19. A method as recited in claim 10, wherein said predetermined action comprises sending an audit message to the mobile transmitter.
- 15
20. A method as recited in claim 19, wherein the audit message is sent automatically to the mobile transmitter upon command from the wireless location system.
21. A wireless location system, comprising:
- 20 (a) means for monitoring the bandwidth of a reverse voice channel (RVC) signal from a mobile transmitter;
- (b) means for determining whether said bandwidth exceeds a predetermined threshold; and
- (c) means for calculating the location of said mobile transmitter if and only if said  
25 bandwidth exceeds said predetermined threshold.
22. A system as recited in claim 21, wherein said mobile transmitter is carried by a user, the system further comprising means for taking an action to cause the mobile transmitter to transmit an RVC signal with a larger bandwidth.
- 30
23. A system as recited in claim 22, further comprising means for asking said user to dial a number of at least 9 digits.

24. A system as recited in claim 22, further comprising means for asking an emergency dispatcher to instruct said user to dial a number of at least 9 digits.
25. A system as recited in claim 21, wherein said predetermined threshold is within the  
5 range of approximately 8 to 12 KHz.
26. A system as recited in claim 25, wherein said predetermined threshold is approximately 10 KHz.
- 10 27. A system as recited in claim 25, wherein said mobile transmitter is carried by a user and the system further comprises means for taking an action to cause the mobile transmitter to transmit an RVC signal of increased bandwidth.
28. A system as recited in claim 22, wherein the system further comprises means for  
15 sending an audit message to the mobile transmitter.
29. A system as recited in claim 28, comprising means for sending the audit message automatically to the mobile transmitter upon command.
- 20 30. A method for use in a wireless location system for locating a mobile transmitter transmitting a signal with a bandwidth, comprising: monitoring the bandwidth, determining whether the bandwidth exceeds a predetermined threshold, and calculating location only if the bandwidth exceeds the threshold.
- 25 31. A method as recited in claim 30, wherein the mobile transmitter is carried by a user, and further comprising taking an action to cause the mobile transmitter to transmit a reverse voice channel (RVC) signal with a larger bandwidth.
- 30 32. A method as recited in claim 31, wherein the action comprises asking the user to dial at least 9 digits.

33. A method as recited in claim 31, wherein the action comprises asking an emergency dispatcher to instruct the user to dial 9 digits.
34. A method as recited in claim 31, wherein the action comprises causing the sending of  
5 an audit message to the mobile transmitter.
35. A method as recited in claim 34, wherein the audit message is sent automatically upon command from the wireless location system.
- 10 36. A method as recited in claim 30, wherein the predetermined threshold is within the range of 8 KHz to 12 KHz.
37. A method as recited in claim 36, wherein the predetermined threshold is approximately  
15 10 KHz.
38. A method as recited in claim 37, wherein the mobile transmitter is carried by a user, and further comprising taking an action to cause the mobile transmitter to transmit a reverse voice channel (RVC) signal with a larger bandwidth.
- 20 39. A method for use in a wireless location system for locating a mobile transmitter, comprising: determining that an emergency situation exists; monitoring the bandwidth of a reverse voice channel (RVC) signal from the mobile transmitter; determining whether the bandwidth exceeds a predetermined threshold; measuring the location of the mobile transmitter if the bandwidth does exceed the threshold; and, if the bandwidth is less than  
25 the threshold, performing a predetermined action to increase the bandwidth and then measuring the location of the mobile transmitter.
40. A method as recited in claim 39, wherein the mobile transmitter is carried by a user, and further comprising taking an action to cause the mobile transmitter to transmit a  
30 reverse voice channel (RVC) signal with a prescribed number of bits.

41. A method as recited in claim 40, wherein the action comprises asking the user to dial at least 9 digits.
42. A method as recited in claim 40, wherein the action comprises asking an emergency dispatcher to instruct the user to dial 9 digits.
43. A method as recited in claim 40, wherein the action comprises causing an audit message to be sent to the mobile transmitter.
44. A method as recited in claim 43, wherein the audit message is sent automatically upon command from the wireless location system.
45. A method as recited in claim 39, wherein the predetermined threshold is within range of 8 KHz to 12 KHz.
46. A method as recited in claim 45, wherein the predetermined threshold is approximately 10 KHz.
47. A method as recited in claim 46, wherein the mobile transmitter is carried by a user, and further comprising taking an action to cause the mobile transmitter to transmit a reverse voice channel (RVC) signal with a larger bandwidth.



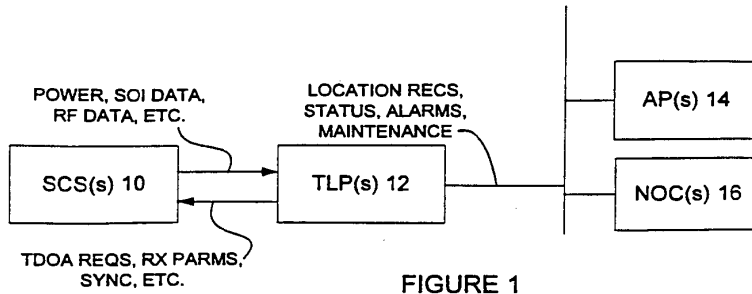


FIGURE 1

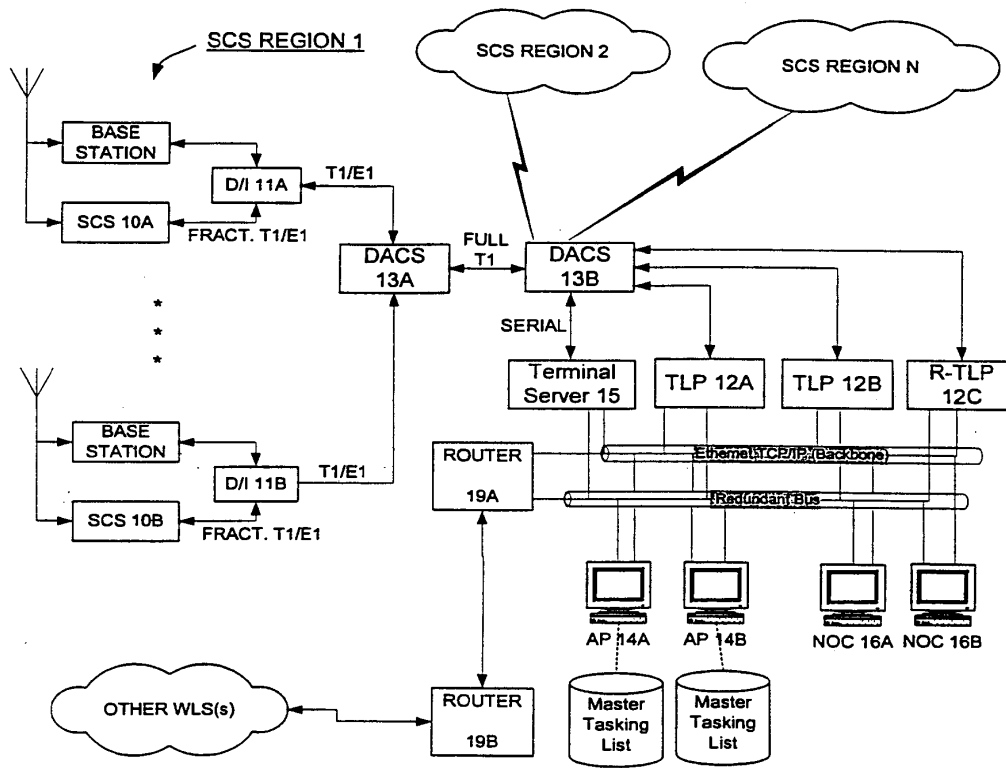


FIGURE 1A

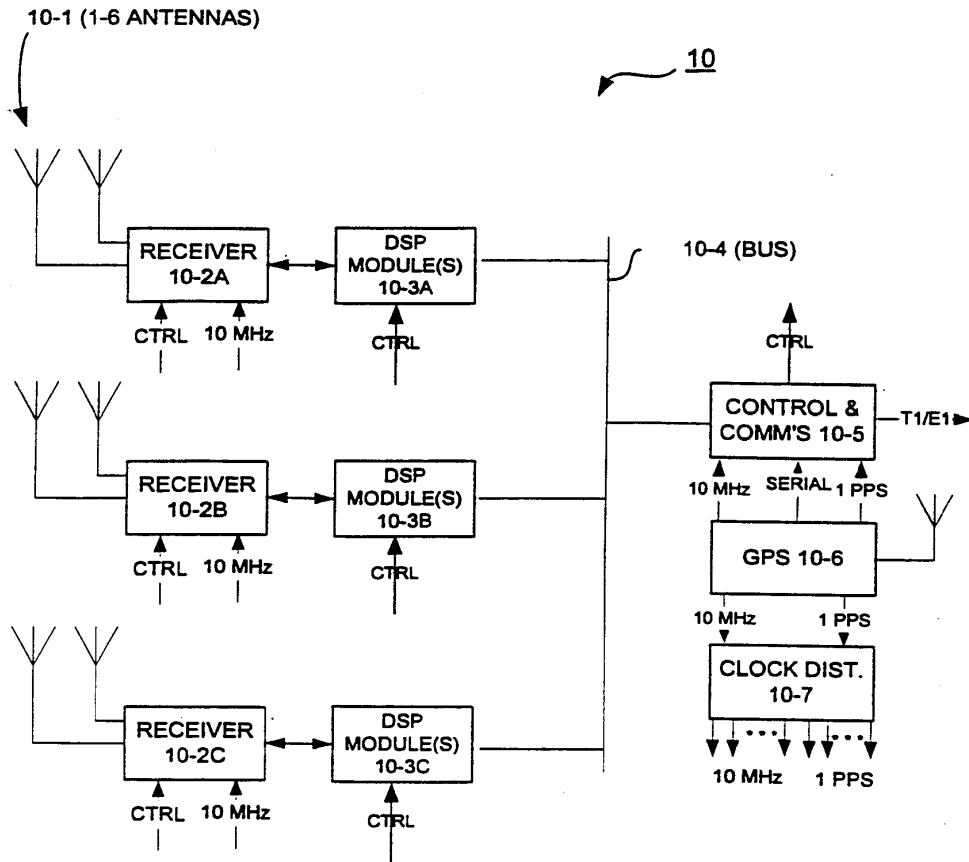


FIGURE 2

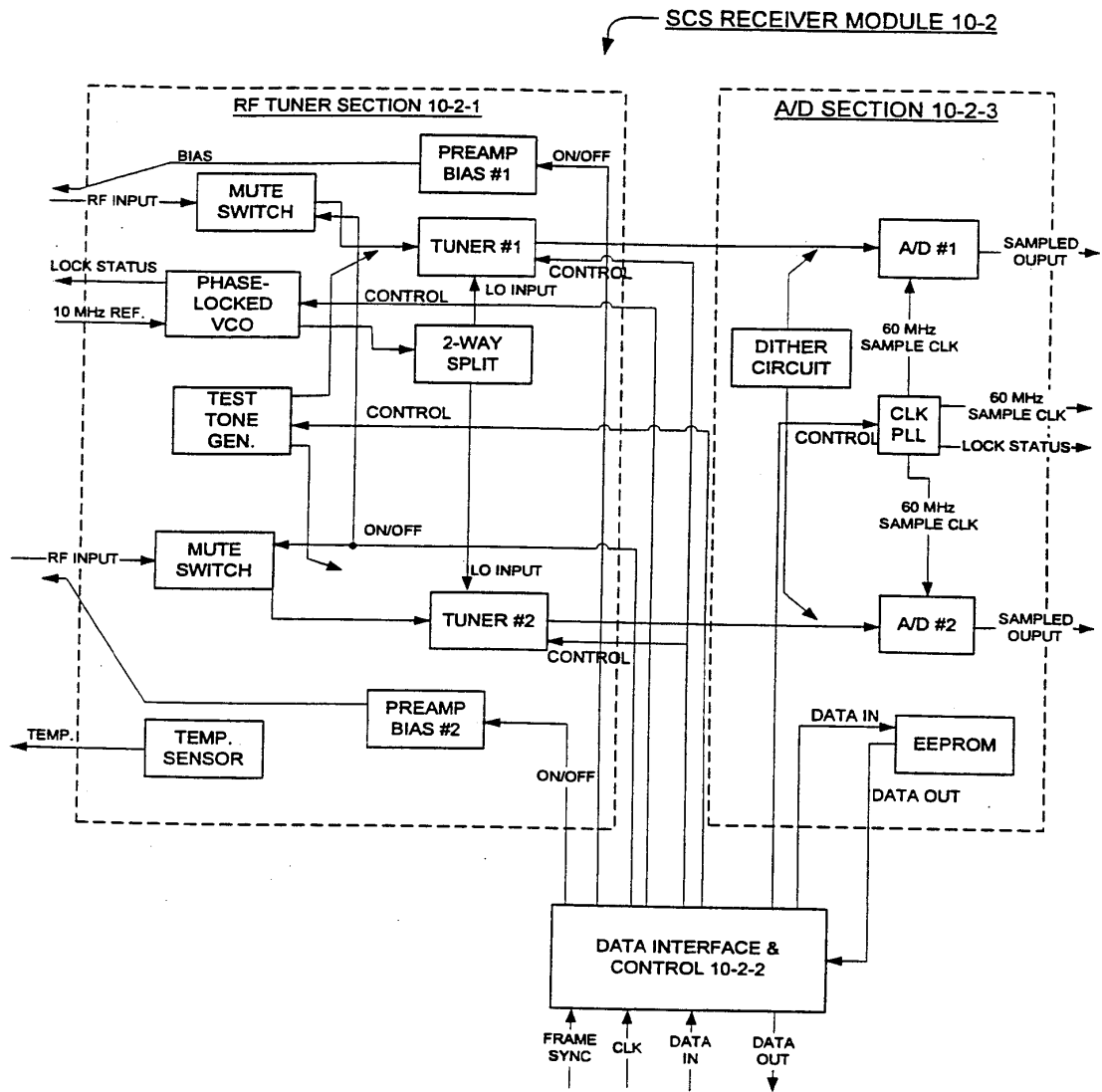


FIGURE 2A

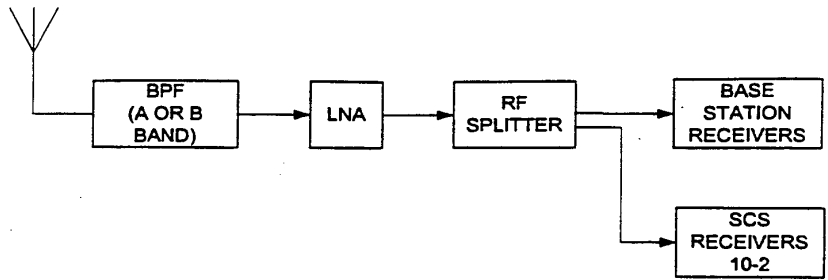


FIGURE 2B

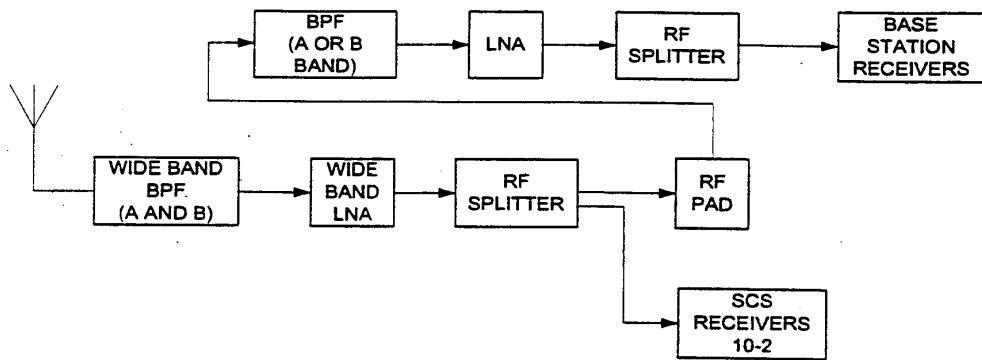


FIGURE 2C

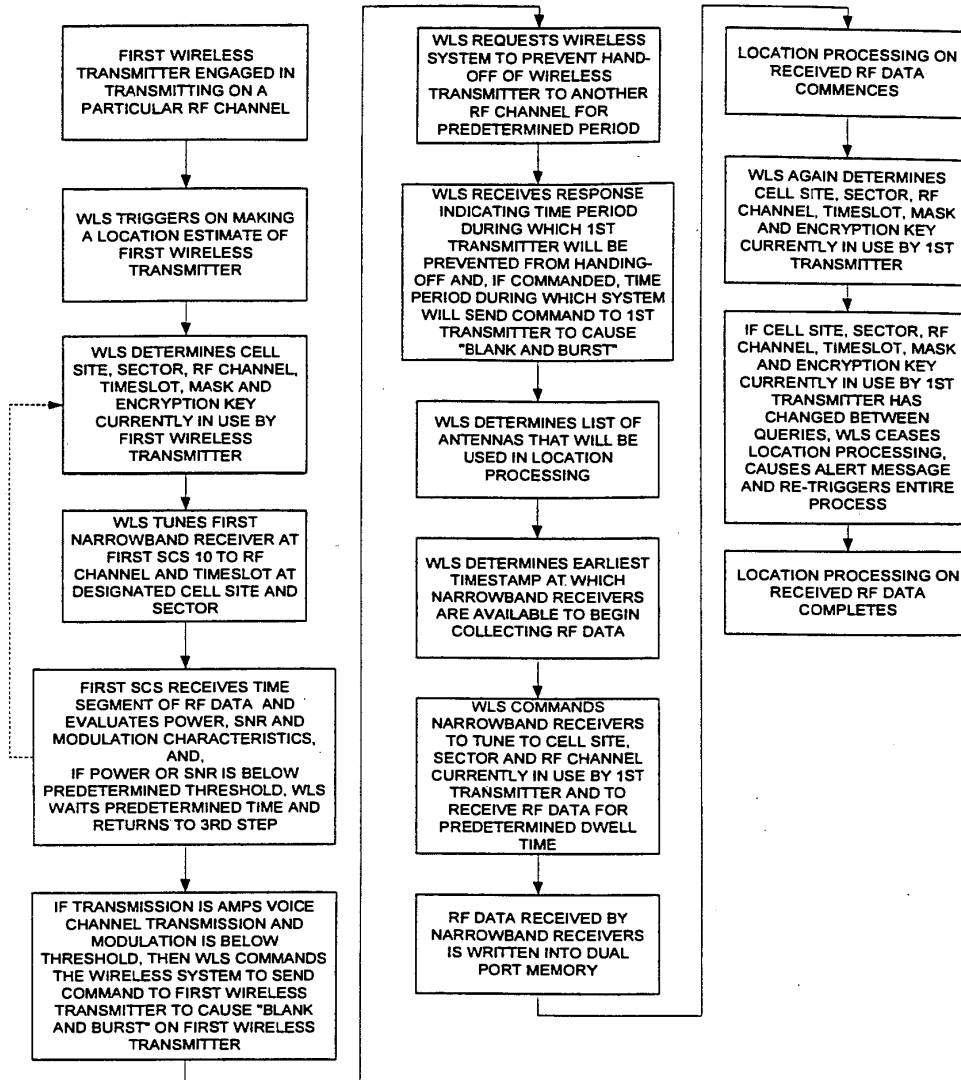


FIGURE 2C-1

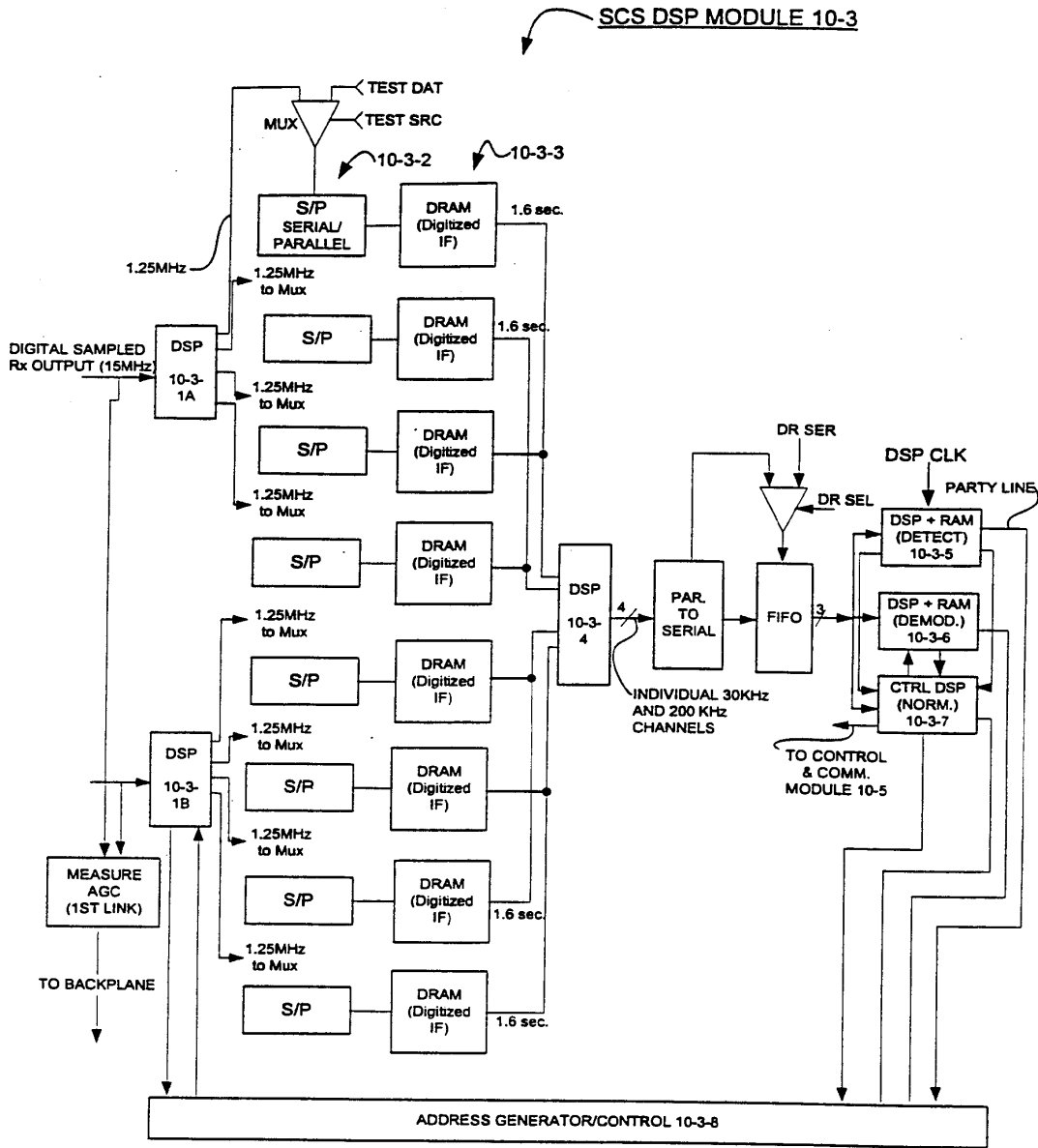


FIGURE 2D

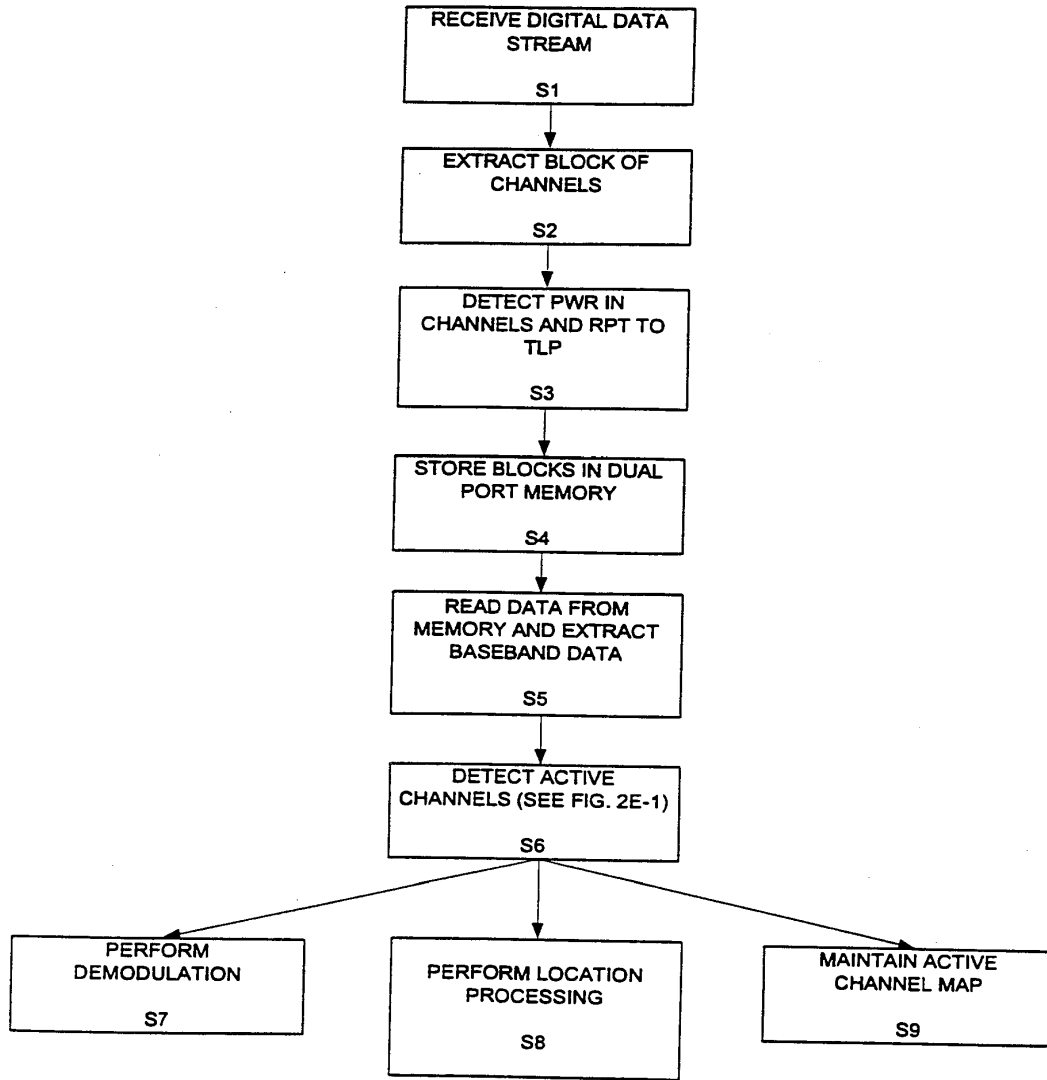


FIGURE 2E

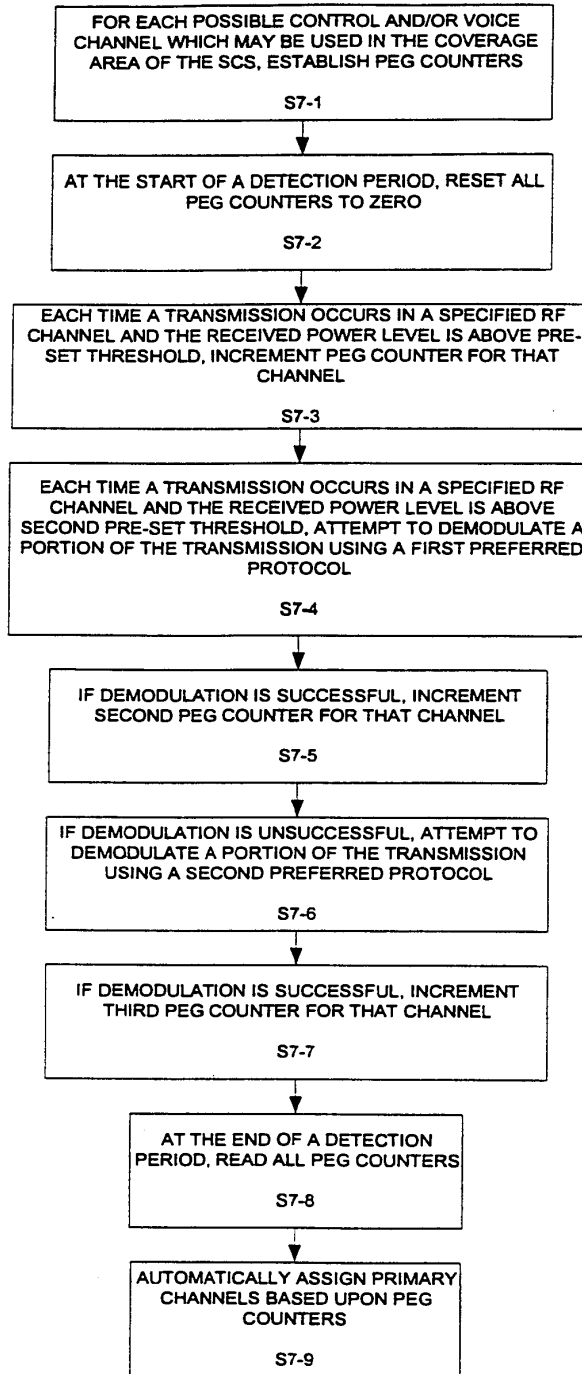


FIGURE 2E-1



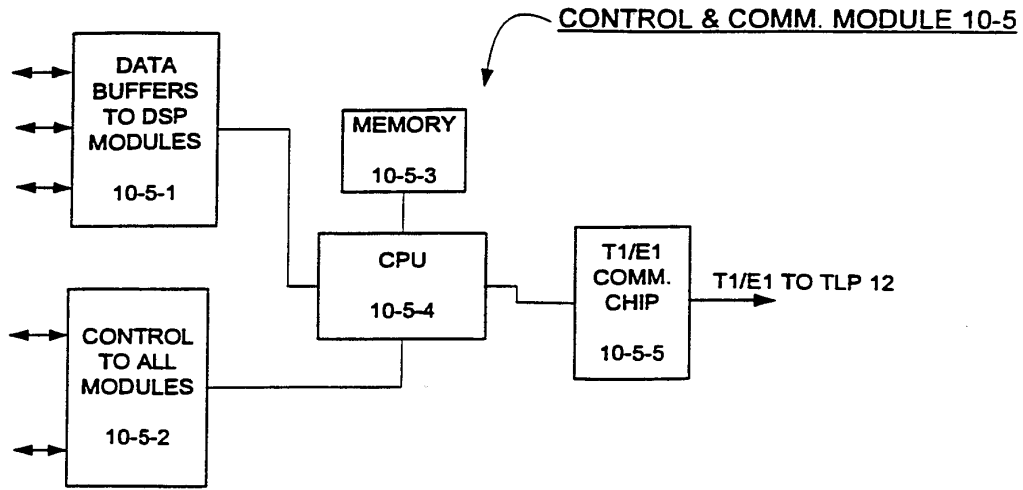


FIGURE 2F

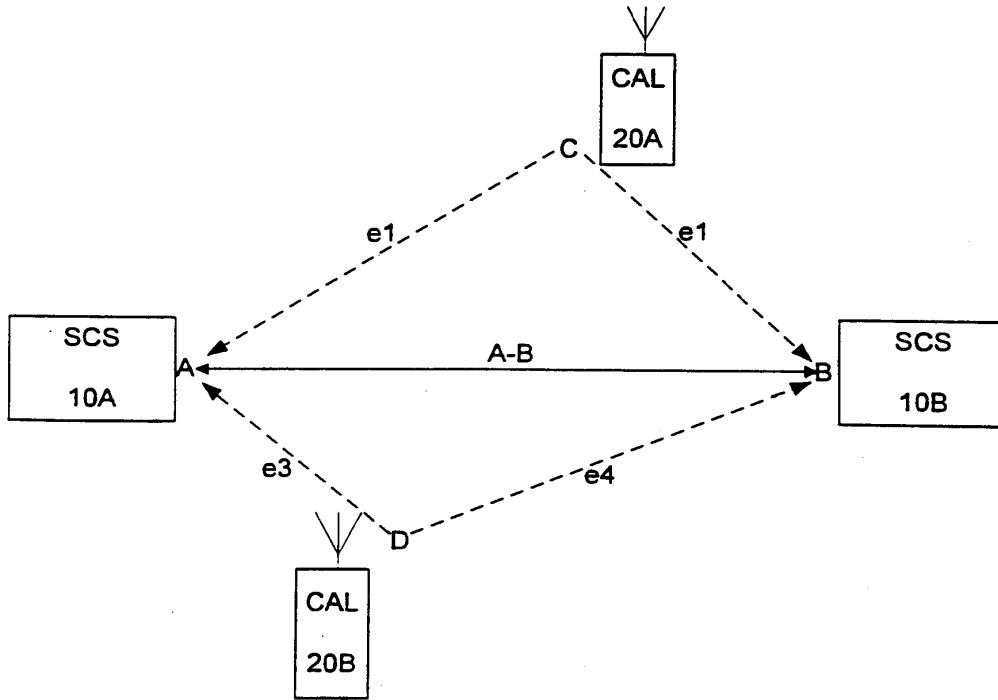


FIGURE 2G

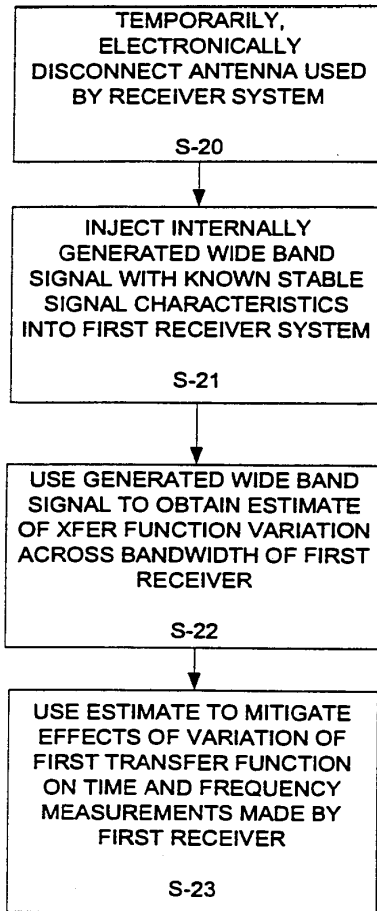


FIGURE 2H

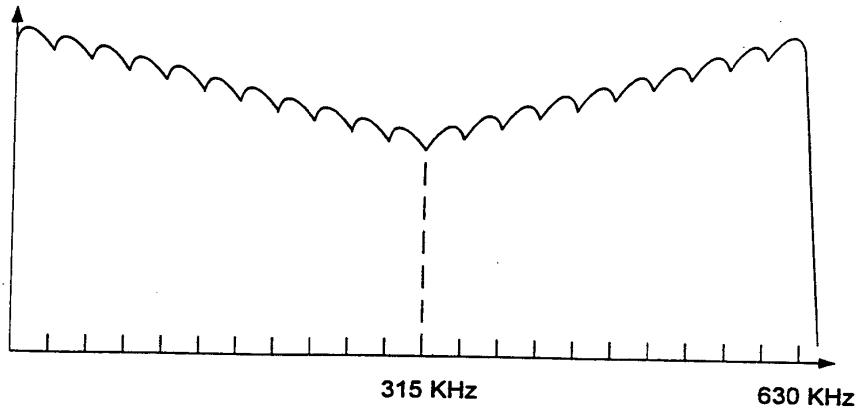


FIGURE 2I

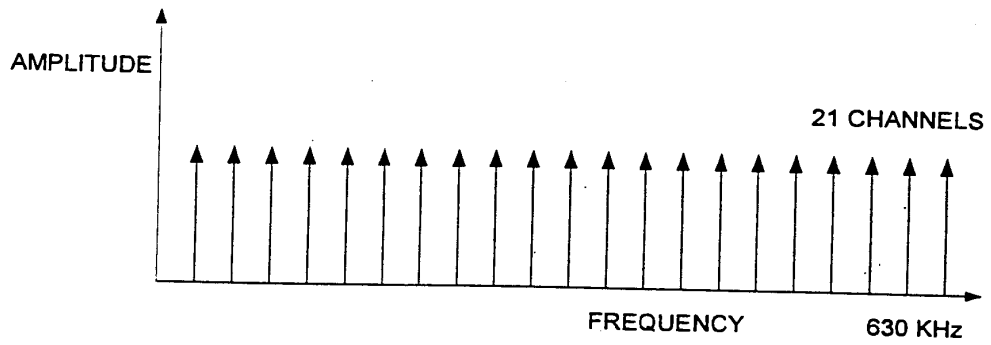


FIGURE 2J

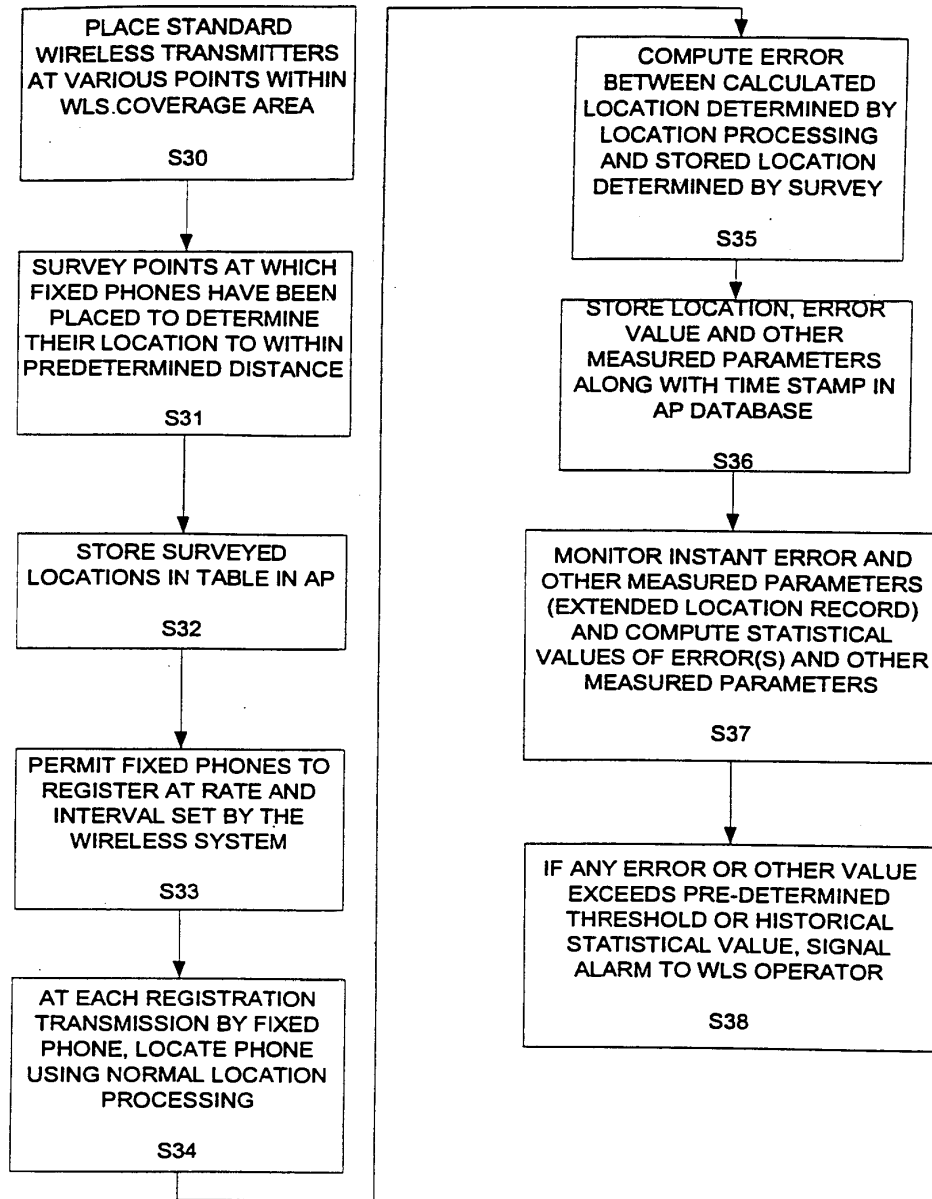


FIGURE 2K

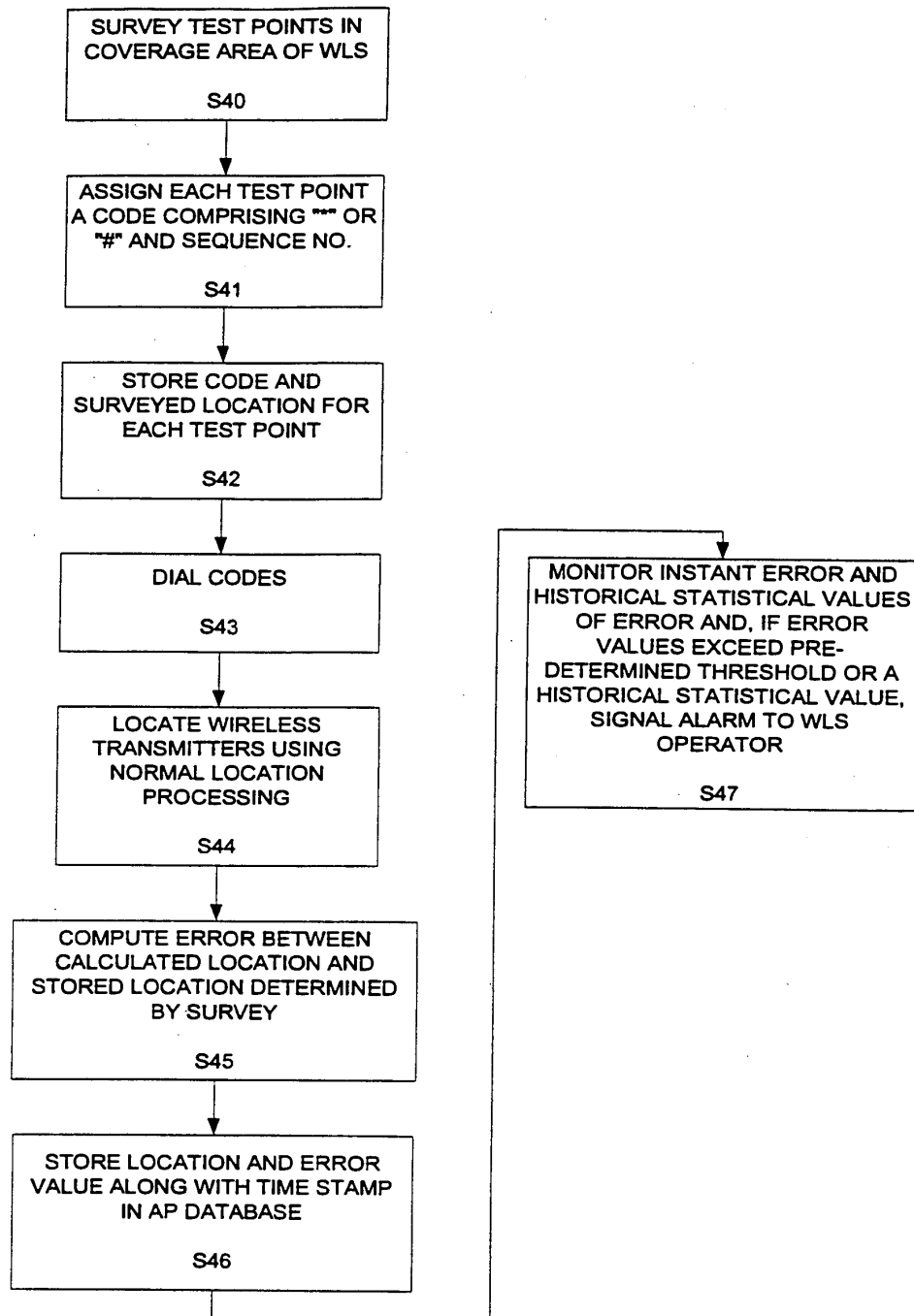


FIGURE 2L

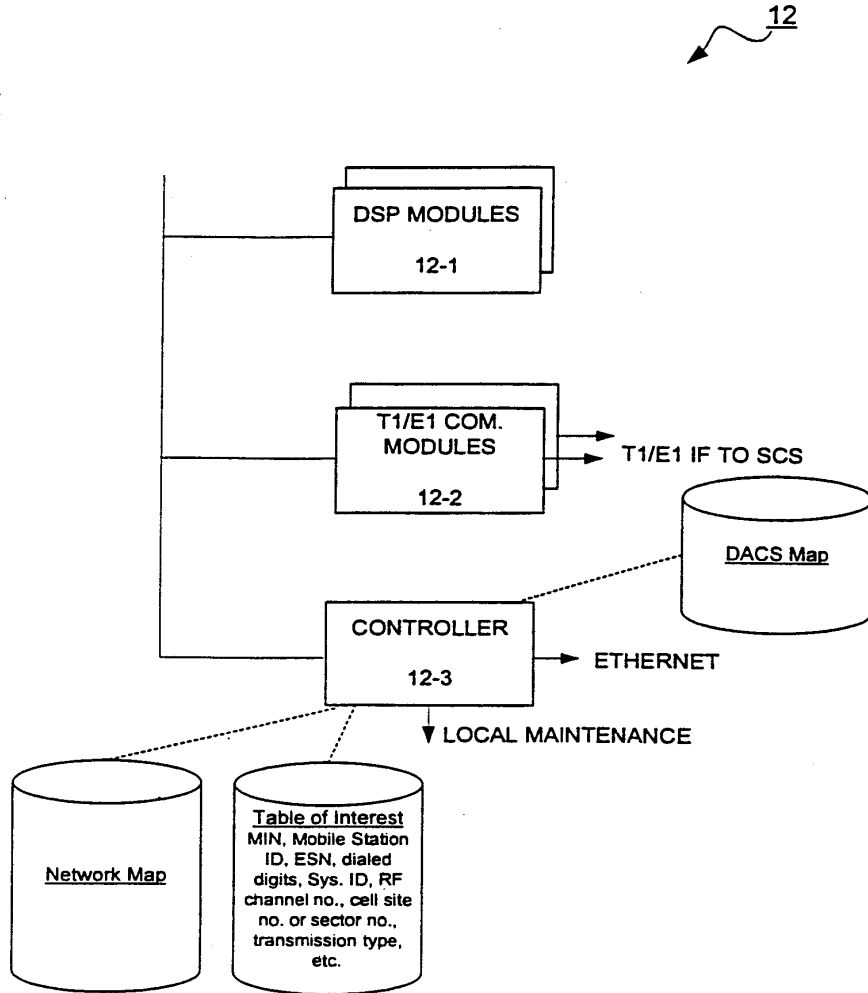


FIGURE 3

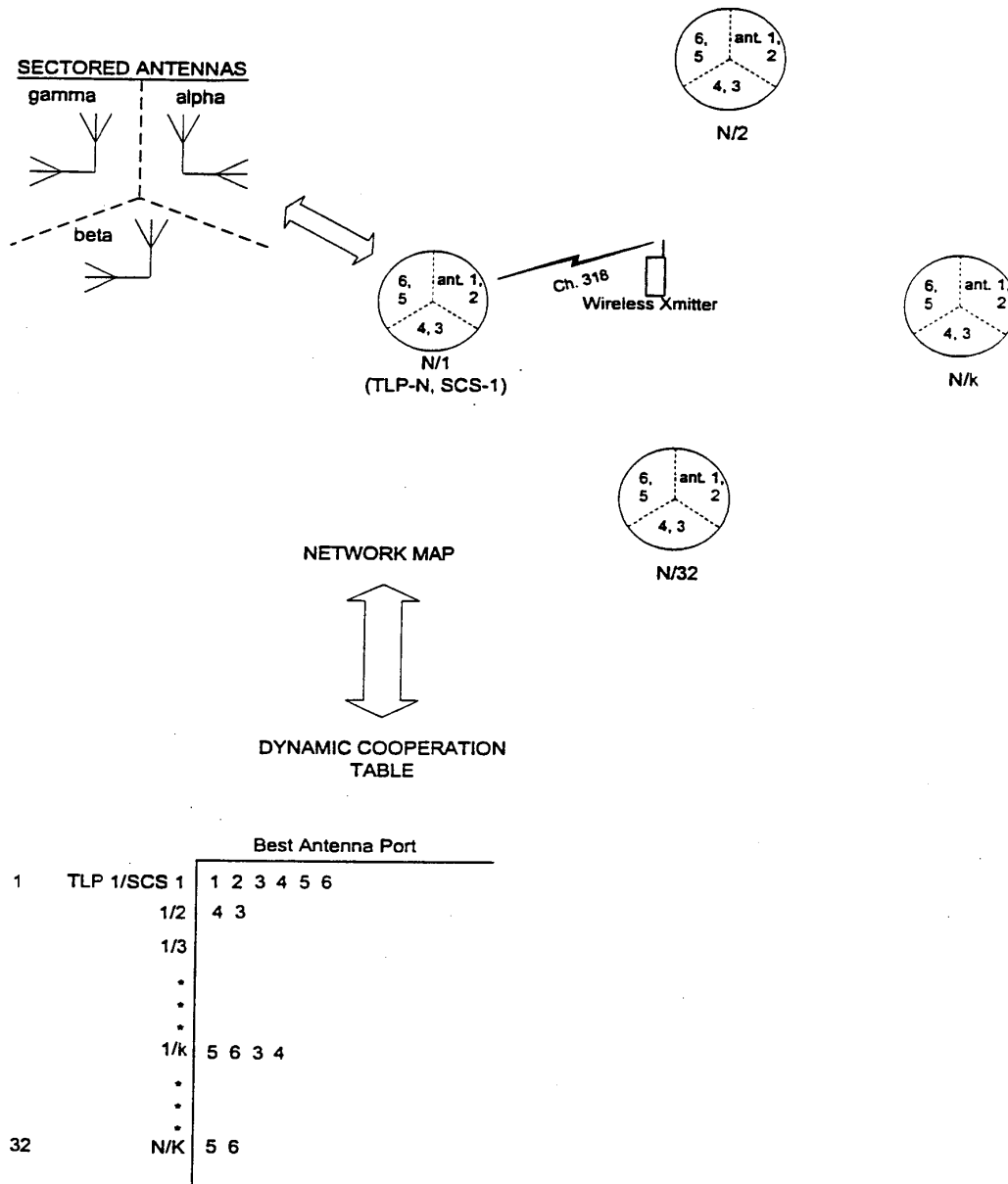


FIGURE 3A

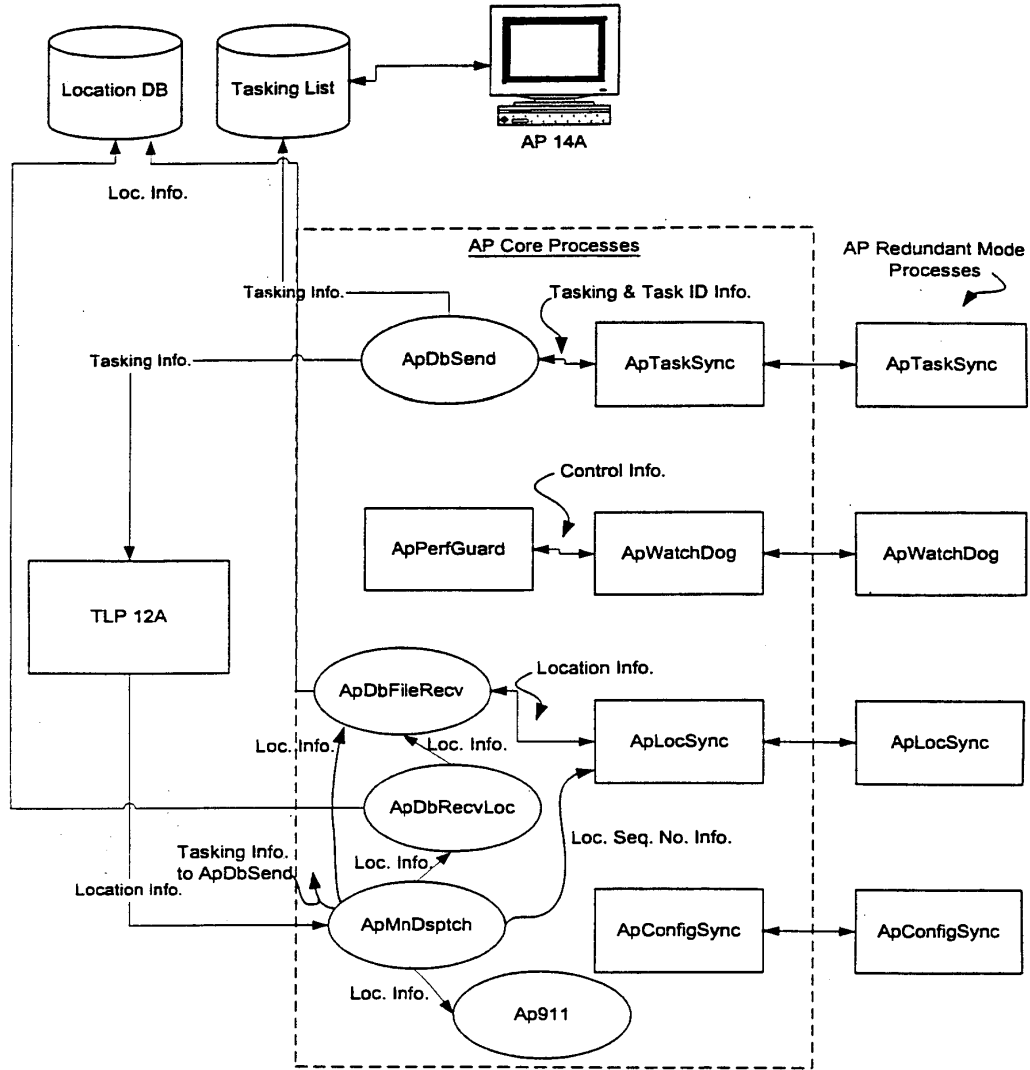


FIGURE 4



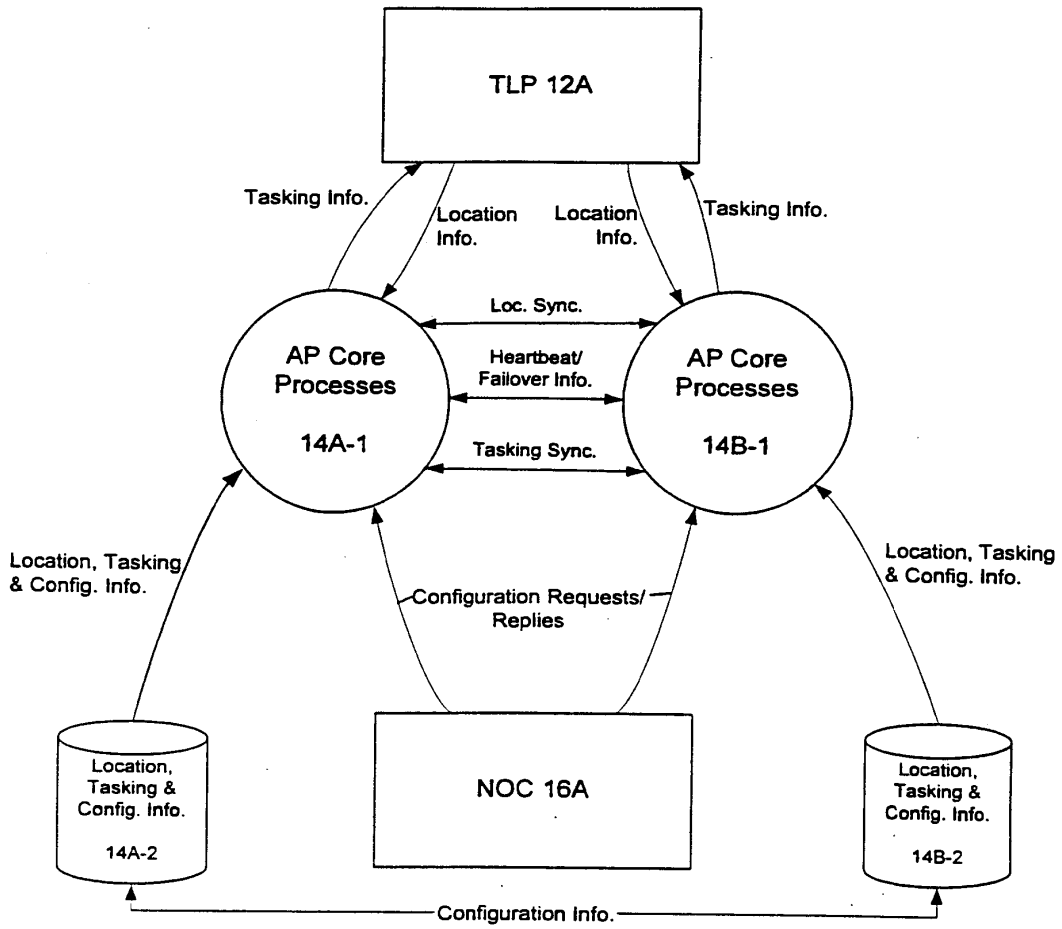


FIGURE 4A

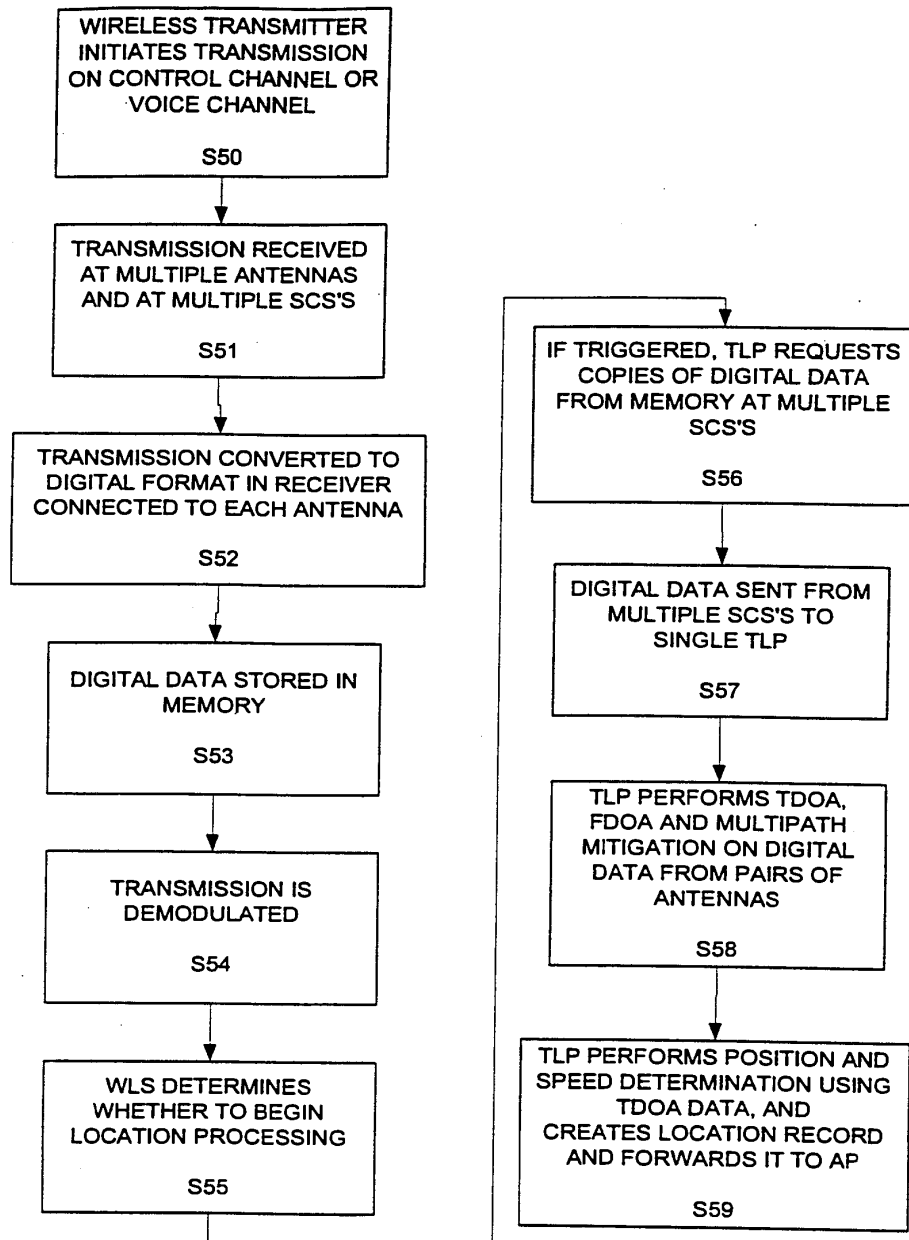


FIGURE 5

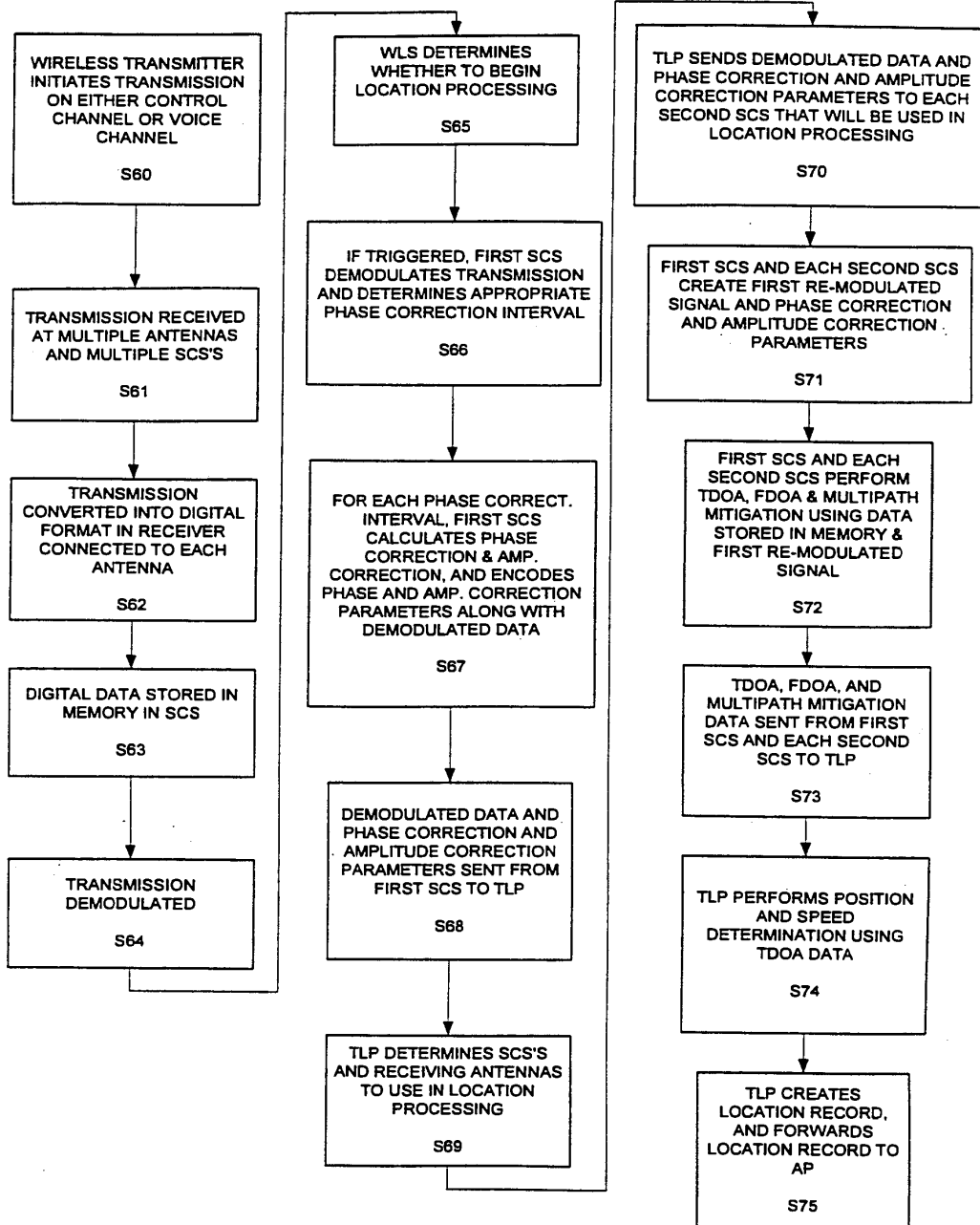


FIGURE 6

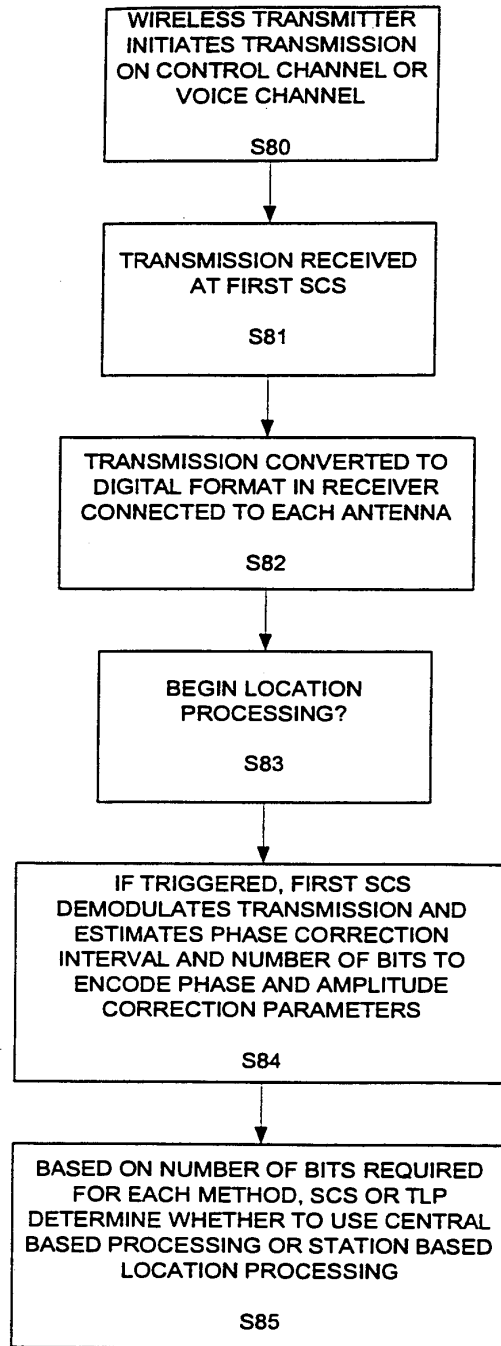


FIGURE 7

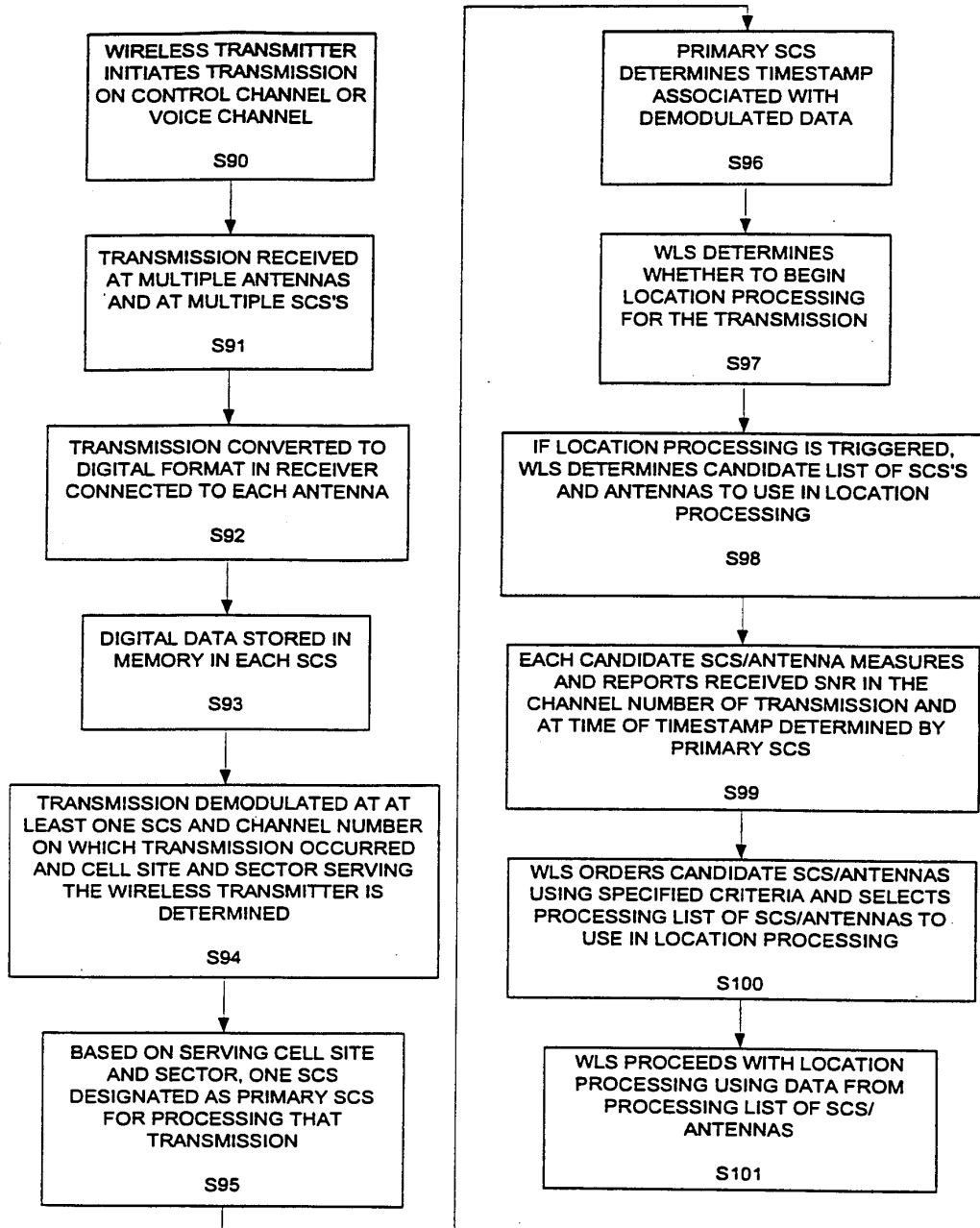


FIGURE 8

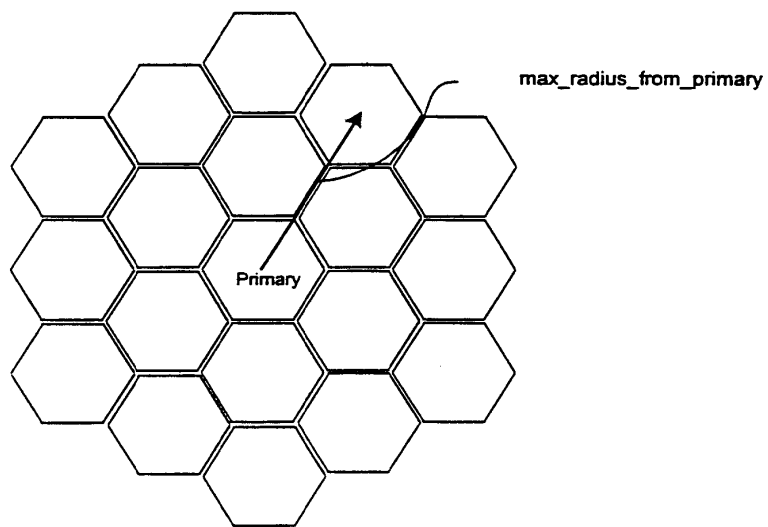


FIGURE 9

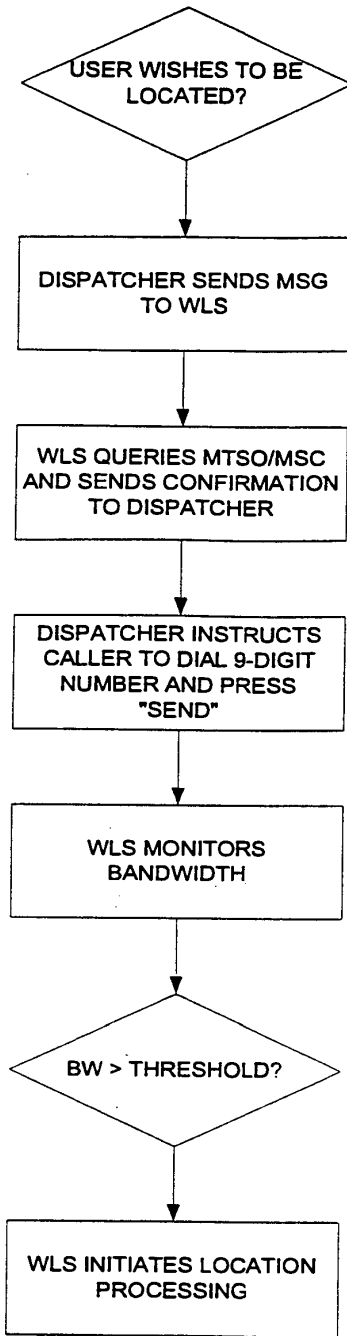


FIGURE 10A

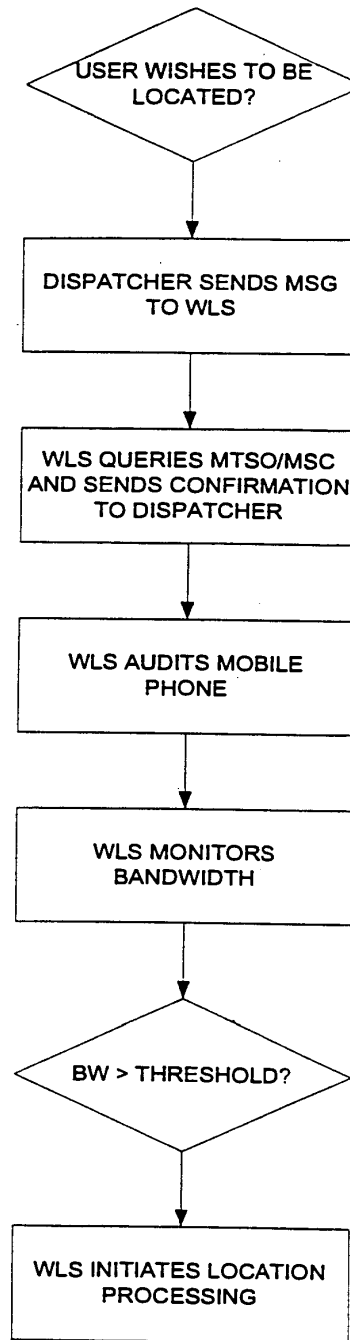


FIGURE 10B

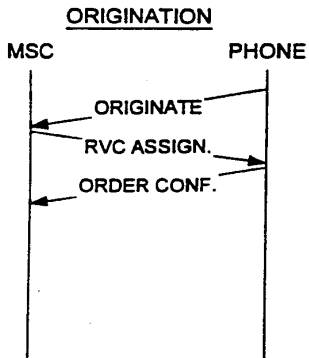


FIGURE 11A

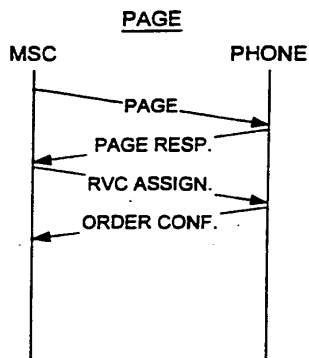


FIGURE 11B

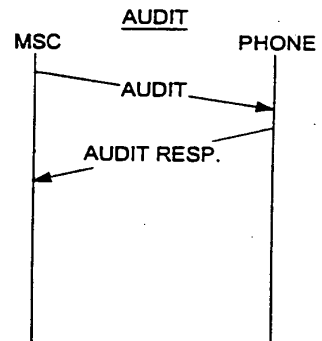


FIGURE 11C

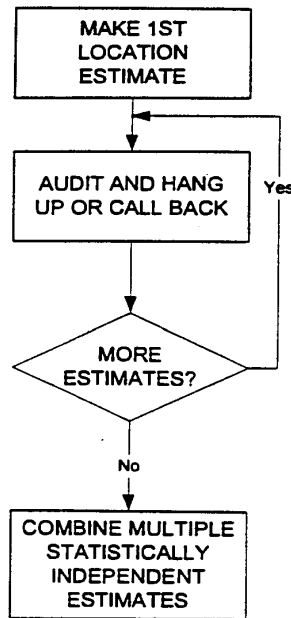


FIGURE 11D



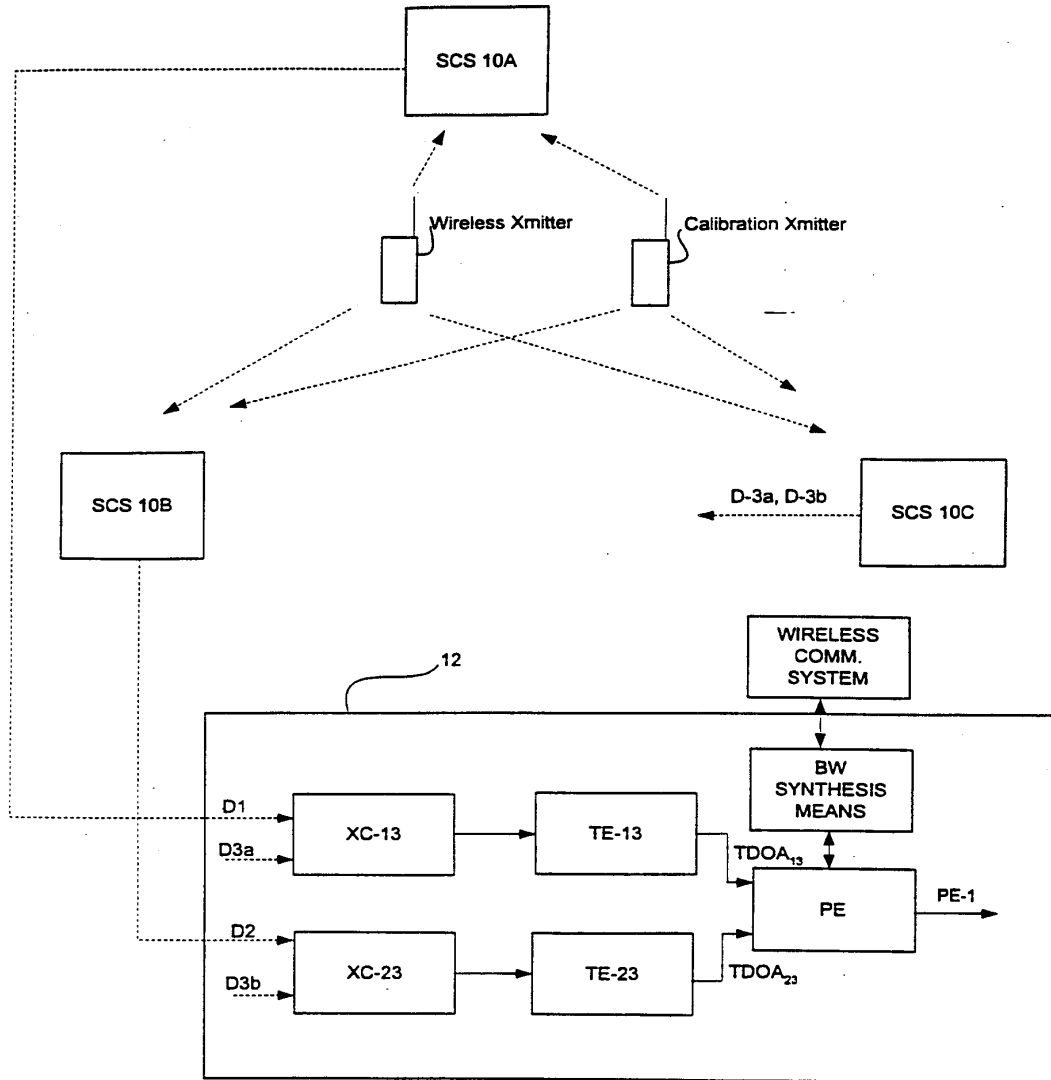


FIGURE 12A

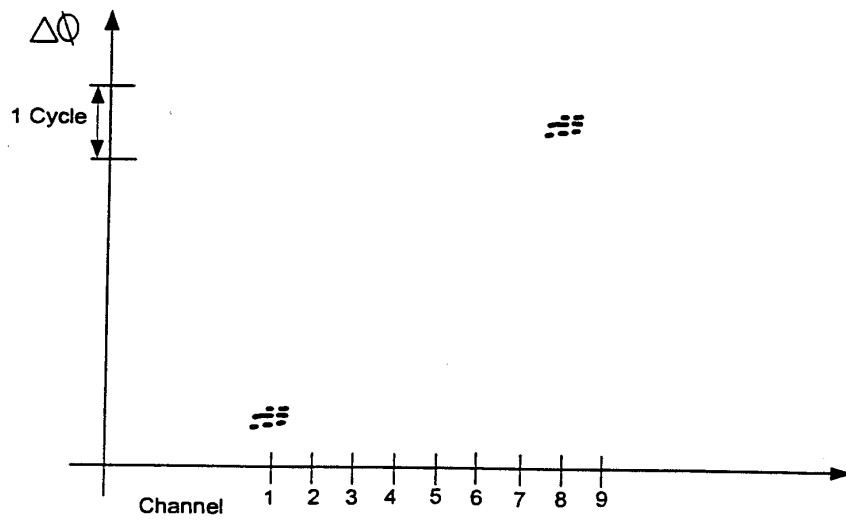


FIGURE 12B

INTERNATIONAL SEARCH REPORT

International application No.  
PCT/US99/29507

| <b>A. CLASSIFICATION OF SUBJECT MATTER</b><br>IPC(7) :G01S 3/02; HO4B 7/185<br>US CL :342/457, 357.01<br>According to International Patent Classification (IPC) or to both national classification and IPC  |  |  |
|---|--|--|
| <b>B. FIELDS SEARCHED</b><br>Minimum documentation searched (classification system followed by classification symbols)<br>U.S. : 342/450, 457,357.01<br>Documentation searched other than minimum documentation to the extent that such documents are included in the fields searched<br>None<br>Electronic data base consulted during the international search (name of data base and, where practicable, search terms used)<br>bandwidth, threshold, rvc, reverse voice |  |  |
| <b>C. DOCUMENTS CONSIDERED TO BE RELEVANT</b>   |  |  |
| Category*   | Citation of document, with indication, where appropriate, of the relevant passages           | Relevant to claim No.  |
| <u>X</u><br>Y   | US 5,402,347 A (MCBURNEY et al) 28 March 1995 (28.3.95); Fig. 1                              | <u>30</u><br>36-37   |
| X   | US 3,921,076 A (CURRIE) 18 November 1975 (18.11.75); Fig. 1, col 3, line 63 - col 4, line 55 | 30   |
| <input type="checkbox"/> Further documents are listed in the continuation of Box C. <input type="checkbox"/> See patent family annex.   |  |  |
| * Special categories of cited documents:  | "T"  | later document published after the international filing date or priority date and not in conflict with the application but cited to understand the principle or theory underlying the invention  |
| "A" document defining the general state of the art which is not considered to be of particular relevance  | "X"  | document of particular relevance; the claimed invention cannot be considered novel or cannot be considered to involve an inventive step when the document is taken alone   |
| "E" earlier document published on or after the international filing date  | "Y"  | document of particular relevance; the claimed invention cannot be considered to involve an inventive step when the document is combined with one or more other such documents, such combination being obvious to a person skilled in the art |
| "L" document which may throw doubts on priority claim(s) or which is cited to establish the publication date of another citation or other special reason (as specified)   | "&"  | document member of the same patent family  |
| "O" document referring to an oral disclosure, use, exhibition or other means  |  |  |
| "P" document published prior to the international filing date but later than the priority date claimed  |  |  |
| Date of the actual completion of the international search<br>07 APRIL 2000  | Date of mailing of the international search report<br><b>16 MAY 2000</b>                     |  |
| Name and mailing address of the ISA/US<br>Commissioner of Patents and Trademarks<br>Box PCT<br>Washington, D.C. 20231<br>Facsimile No. (703) 305-3230   | Authorized officer <i>Dao L. Phan</i><br>DAO L. PHAN<br>Telephone No. (703) 306-4167         |  |

Form PCT/ISA/210 (second sheet) (July 1998)★



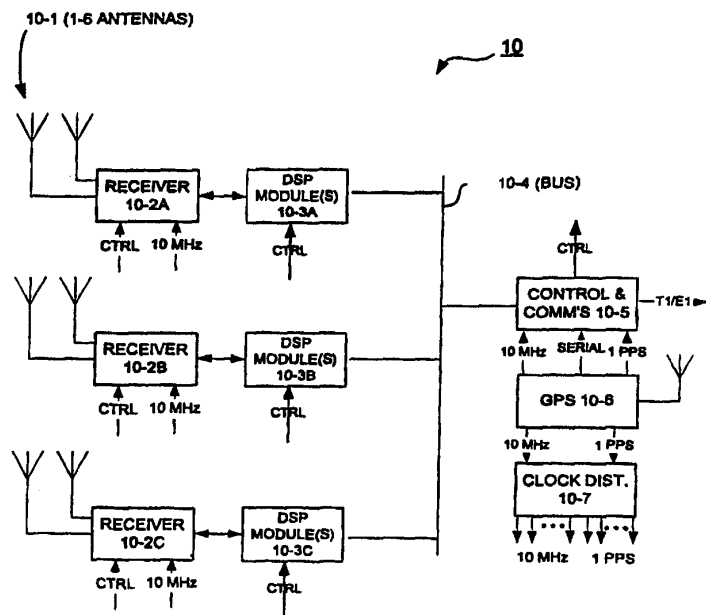
INTERNATIONAL APPLICATION PUBLISHED UNDER THE PATENT COOPERATION TREATY (PCT)

|  |                  |   |
|--|------------------|---|
| <p>(51) International Patent Classification <sup>7</sup> :<br/><b>H04Q</b></p>   | <p><b>A2</b></p> | <p>(11) International Publication Number: <b>WO 00/41402</b><br/>(43) International Publication Date: 13 July 2000 (13.07.00)</p>   |
| <p>(21) International Application Number: PCT/US99/29463<br/>(22) International Filing Date: 13 December 1999 (13.12.99)<br/>(30) Priority Data:<br/>09/227,764 8 January 1999 (08.01.99) US<br/>09/228,362 11 January 1999 (11.01.99) US<br/>(71) Applicant: TRUEPOSITION, INC. [US/US]; 780 Fifth Avenue, King of Prussia, PA 19406 (US).<br/>(72) Inventors: STILP, Louis, A.; 1435 Byrd Drive, Berwyn, PA 19312 (US). SHEENAN, Joseph, W.; 26 Canter Drive, Newtown Square, PA 19073 (US). HARRIS, Tim, J.; 97 Ashland Avenue # 4B, Bala Cynwyd, PA 19004 (US). BULL, Jeffrey, F.; 100 Aspen Court, Chalfont, PA 18914 (US). ANDERSON, Robert, J.; 704 Deer Run, Norristown, PA 19403 (US).<br/>(74) Agents: NORRIS, Norman, L. et al.; Woodcock Washburn Kurtz Mackiewicz &amp; Norris LLP, 46th floor, One Liberty Place, Philadelphia, PA 19103 (US).</p> |                  | <p>(81) Designated States: AE, AL, AM, AT, AU, AZ, BA, BB, BG, BR, BY, CA, CH, CN, CR, CU, CZ, DE, DK, DM, EE, ES, FI, GB, GD, GE, GH, GM, HR, HU, ID, IL, IN, IS, JP, KE, KG, KP, KR, KZ, LC, LK, LR, LS, LT, LU, LV, MD, MG, MK, MN, MW, MX, NO, NZ, PL, PT, RO, RU, SD, SE, SG, SI, SK, SL, TJ, TM, TR, TT, TZ, UA, UG, UZ, VN, YU, ZA, ZW, ARIPO patent (GH, GM, KE, LS, MW, SD, SL, SZ, TZ, UG, ZW), Eurasian patent (AM, AZ, BY, KG, KZ, MD, RU, TJ, TM), European patent (AT, BE, CH, CY, DE, DK, ES, FI, FR, GB, GR, IE, IT, LU, MC, NL, PT, SE), OAPI patent (BF, BJ, CF, CG, CI, CM, GA, GN, GW, ML, MR, NE, SN, TD, TG).</p> <p><b>Published</b><br/><i>Without international search report and to be republished upon receipt of that report.</i></p> |

(54) Title: ARCHITECTURE FOR A SIGNAL COLLECTION SYSTEM OF A WIRELESS LOCATION SYSTEM

(57) Abstract

A signal collection system (SCS) for use in a Wireless Location System is disclosed. The SCS performs wideband energy detection and reporting at the front end of the SCS receiver. Other aspects of the SCS include a protocol for efficiently setting levels for wideband energy detection, DSP sharing within an SCS, and recursive location processing using progressively greater bandwidth from temporarily stored wideband data. The disclosed SCS includes antennas, a wideband receiver, a DSP for wideband energy detection, a memory for temporarily storing digital samples of received signals, a digital drop receiver, demodulation and normalization processors, and a communications processor. The wideband energy detection and the demodulation and normalization processors are implemented with DSP's that detect energy in a particular band, demodulate selected signals, and extract signals of interest for forwarding. The wideband energy detection unit determines the presence of a transmitted signal in the control channels monitored by the SCS. The wideband energy detection involves forming a map of the channel spectrum, and the map is used to determine when to demodulate signals within selected channels.



**FOR THE PURPOSES OF INFORMATION ONLY**

Codes used to identify States party to the PCT on the front pages of pamphlets publishing international applications under the PCT.

|           |                          |           |  |           |  |           |                          |
|-----------|--------------------------|-----------|--|-----------|--|-----------|--------------------------|
| <b>AL</b> | Albania                  | <b>ES</b> | Spain                                    | <b>LS</b> | Lesotho                                      | <b>SI</b> | Slovenia                 |
| <b>AM</b> | Armenia                  | <b>FI</b> | Finland                                  | <b>LT</b> | Lithuania                                    | <b>SK</b> | Slovakia                 |
| <b>AT</b> | Austria                  | <b>FR</b> | France                                   | <b>LU</b> | Luxembourg                                   | <b>SN</b> | Senegal                  |
| <b>AU</b> | Australia                | <b>GA</b> | Gabon                                    | <b>LV</b> | Latvia                                       | <b>SZ</b> | Swaziland                |
| <b>AZ</b> | Azerbaijan               | <b>GB</b> | United Kingdom                           | <b>MC</b> | Monaco                                       | <b>TD</b> | Chad                     |
| <b>BA</b> | Bosnia and Herzegovina   | <b>GE</b> | Georgia                                  | <b>MD</b> | Republic of Moldova                          | <b>TG</b> | Togo                     |
| <b>BB</b> | Barbados                 | <b>GH</b> | Ghana                                    | <b>MG</b> | Madagascar                                   | <b>TJ</b> | Tajikistan               |
| <b>BE</b> | Belgium                  | <b>GN</b> | Guinea                                   | <b>MK</b> | The former Yugoslav<br>Republic of Macedonia | <b>TM</b> | Turkmenistan             |
| <b>BF</b> | Burkina Faso             | <b>GR</b> | Greece                                   |           |  | <b>TR</b> | Turkey                   |
| <b>BG</b> | Bulgaria                 | <b>HU</b> | Hungary                                  | <b>ML</b> | Mali   | <b>TT</b> | Trinidad and Tobago      |
| <b>BJ</b> | Benin                    | <b>IE</b> | Ireland                                  | <b>MN</b> | Mongolia                                     | <b>UA</b> | Ukraine                  |
| <b>BR</b> | Brazil                   | <b>IL</b> | Israel                                   | <b>MR</b> | Mauritania                                   | <b>UG</b> | Uganda                   |
| <b>BY</b> | Belarus                  | <b>IS</b> | Iceland                                  | <b>MW</b> | Malawi                                       | <b>US</b> | United States of America |
| <b>CA</b> | Canada                   | <b>IT</b> | Italy                                    | <b>MX</b> | Mexico                                       | <b>UZ</b> | Uzbekistan               |
| <b>CF</b> | Central African Republic | <b>JP</b> | Japan                                    | <b>NE</b> | Niger  | <b>VN</b> | Viet Nam                 |
| <b>CG</b> | Congo                    | <b>KE</b> | Kenya                                    | <b>NL</b> | Netherlands                                  | <b>YU</b> | Yugoslavia               |
| <b>CH</b> | Switzerland              | <b>KG</b> | Kyrgyzstan                               | <b>NO</b> | Norway                                       | <b>ZW</b> | Zimbabwe                 |
| <b>CI</b> | Côte d'Ivoire            | <b>KP</b> | Democratic People's<br>Republic of Korea | <b>NZ</b> | New Zealand                                  |           |                          |
| <b>CM</b> | Cameroon                 |           |  | <b>PL</b> | Poland                                       |           |                          |
| <b>CN</b> | China                    | <b>KR</b> | Republic of Korea                        | <b>PT</b> | Portugal                                     |           |                          |
| <b>CU</b> | Cuba                     | <b>KZ</b> | Kazakstan                                | <b>RO</b> | Romania                                      |           |                          |
| <b>CZ</b> | Czech Republic           | <b>LC</b> | Saint Lucia                              | <b>RU</b> | Russian Federation                           |           |                          |
| <b>DE</b> | Germany                  | <b>LI</b> | Liechtenstein                            | <b>SD</b> | Sudan  |           |                          |
| <b>DK</b> | Denmark                  | <b>LK</b> | Sri Lanka                                | <b>SE</b> | Sweden                                       |           |                          |
| <b>EE</b> | Estonia                  | <b>LR</b> | Liberia                                  | <b>SG</b> | Singapore                                    |           |                          |

**ARCHITECTURE FOR A SIGNAL COLLECTION SYSTEM  
OF A WIRELESS LOCATION SYSTEM**

**CROSS REFERENCE TO RELATED APPLICATIONS**

- 5 This is a continuation of U.S. Patent Application Serial No. \_\_ (attorney docket ACOM-0091), filed on January 8, 1999, entitled "Calibration for Wireless Location System."

**FIELD OF THE INVENTION**

10 The present invention relates generally to methods and apparatus for locating wireless transmitters, such as those used in analog or digital cellular systems, personnel communications systems (PCS), enhanced specialized mobile radios (ESMRs), and other types of wireless communications systems. This field is now generally known as wireless location, and has application for Wireless E9-1-1, fleet management, RF optimization, and other valuable applications.

15

**BACKGROUND OF THE INVENTION**

Early work relating to the present invention has been described in U.S. Patent Number 5,327,144, July 5, 1994, "Cellular Telephone Location System," which discloses a system for locating cellular telephones using novel time difference of arrival (TDOA) techniques.

20 Further enhancements of the system disclosed in the '144 patent are disclosed in U.S. Patent Number 5,608,410, March 4, 1997, "System for Locating a Source of Bursty Transmissions." Both patents are owned by the assignee of the current invention, and both are incorporated herein by reference. The present inventors have continued to develop significant enhancements to the original inventive concepts and have developed

25 techniques to further improve the accuracy of Wireless Location Systems while significantly reducing the cost of these systems.

Over the past few years, the cellular industry has increased the number of air interface protocols available for use by wireless telephones, increased the number of frequency

30 bands in which wireless or mobile telephones may operate, and expanded the number of terms that refer or relate to mobile telephones to include "personal communications services", "wireless", and others. The air interface protocols now include AMPS, N-

AMPS, TDMA, CDMA, GSM, TACS, ESMR, and others. The changes in terminology and increases in the number of air interfaces do not change the basic principles and inventions discovered and enhanced by the inventors. However, in keeping with the current terminology of the industry, the inventors now call the system described herein a *Wireless*  
5 *Location System*.

The inventors have conducted extensive experiments with the Wireless Location System technology disclosed herein to demonstrate both the viability and value of the technology. For example, several experiments were conducted during several months of 1995 and  
10 1996 in the cities of Philadelphia and Baltimore to verify the system's ability to mitigate multipath in large urban environments. Then, in 1996 the inventors constructed a system in Houston that was used to test the technology's effectiveness in that area and its ability to interface directly with E9-1-1 systems. Then, in 1997, the system was tested in a 350 square mile area in New Jersey and was used to locate real 9-1-1 calls from real people in  
15 trouble. Since that time, the system test has been expanded to include 125 cell sites covering an area of over 2,000 square miles. During all of these tests, techniques discussed and disclosed herein were tested for effectiveness and further developed, and the system has been demonstrated to overcome the limitations of other approaches that have been proposed for locating wireless telephones. Indeed, as of December, 1998, no other  
20 Wireless Location System has been installed anywhere else in the world that is capable of locating live 9-1-1 callers. The innovation of the Wireless Location System disclosed herein has been acknowledged in the wireless industry by the extensive amount of media coverage given to the system's capabilities, as well as by awards. For example, the prestigious Wireless Appy Award was granted to the system by the Cellular Telephone  
25 Industry Association in October, 1997, and the Christopher Columbus Fellowship Foundation and Discover Magazine found the Wireless Location System to be one of the top 4 innovations of 1998 out of 4,000 nominations submitted.

The value and importance of the Wireless Location System has been acknowledged by the  
30 wireless communications industry. In June 1996, the Federal Communications Commission issued requirements for the wireless communications industry to deploy location systems for use in locating wireless 9-1-1 callers, with a deadline of October

2001. The location of wireless E9-1-1 callers will save response time, save lives, and save enormous costs because of reduced use of emergency responses resources. In addition, numerous surveys and studies have concluded that various wireless applications, such as location sensitive billing, fleet management, and others, will have great commercial values  
5 in the coming years.

#### Background on Wireless Communications Systems

There are many different types of air interface protocols used for wireless communications systems. These protocols are used in different frequency bands, both in the U.S. and  
10 internationally. The frequency band does not impact the Wireless Location System's effectiveness at locating wireless telephones.

All air interface protocols use two types of "channels". The first type includes control channels that are used for conveying information about the wireless telephone or  
15 transmitter, for initiating or terminating calls, or for transferring bursty data. For example, some types of short messaging services transfer data over the control channel. In different air interfaces, control channels are known by different terminology, but the use of the control channels in each air interface is similar. Control channels generally have identifying information about the wireless telephone or transmitter contained in the  
20 transmission.

The second type includes voice channels that are typically used for conveying voice communications over the air interface. These channels are only used after a call has been set up using the control channels. Voice channels will typically use dedicated resources  
25 within the wireless communications system whereas control channels will use shared resources. This distinction will generally make the use of control channels for wireless location purposes more cost effective than the use of voice channels, although there are some applications for which regular location on the voice channel is desired. Voice channels generally do not have identifying information about the wireless telephone or  
30 transmitter in the transmission. Some of the differences in the air interface protocols are discussed below:



AMPS – This is the original air interface protocol used for cellular communications in the U.S. In the AMPS system, separate dedicated channels are assigned for use by control channels (RCC). According to the TIA/EIA Standard IS-553A, every control channel block must begin at cellular channel 333 or 334, but the block may be of variable length.

5 In the U.S., by convention, the AMPS control channel block is 21 channels wide, but the use of a 26-channel block is also known. A reverse voice channel (RVC) may occupy any channel that is not assigned to a control channel. The control channel modulation is FSK (frequency shift keying), while the voice channels are modulated using FM (frequency modulation).

10

N-AMPS – This air interface is an expansion of the AMPS air interface protocol, and is defined in EIA/TIA standard IS-88. The control channels are substantially the same as for AMPS, however, the voice channels are different. The voice channels occupy less than 10 KHz of bandwidth, versus the 30 KHz used for AMPS, and the modulation is FM.

15

TDMA – This interface is also known D-AMPS, and is defined in EIA/TIA standard IS-136. This air interface is characterized by the use of both frequency and time separation. Control channels are known as Digital Control Channels (DCCH) and are transmitted in bursts in timeslots assigned for use by DCCH. Unlike AMPS, DCCH may be assigned

20 anywhere in the frequency band, although there are generally some frequency assignments that are more attractive than others based upon the use of probability blocks. Voice channels are known as Digital Traffic Channels (DTC). DCCH and DTC may occupy the same frequency assignments, but not the same timeslot assignment in a given frequency assignment. DCCH and DTC use the same modulation scheme, known as  $\pi/4$  DQPSK

25 (differential quadrature phase shift keying). In the cellular band, a carrier may use both the AMPS and TDMA protocols, as long as the frequency assignments for each protocol are kept separated.

CDMA – This air interface is defined by EIA/TIA standard IS-95A. This air interface is

30 characterized by the use of both frequency and code separation. However, because adjacent cell sites may use the same frequency sets, CDMA is also characterized by very careful power control. This careful power control leads to a situation known to those

skilled in the art as the near-far problem, which makes wireless location difficult for most approaches to function properly. Control channels are known as Access Channels, and voice channels are known as Traffic Channels. Access and Traffic Channels may share the same frequency band, but are separated by code. Access and Traffic Channels use the  
5 same modulation scheme, known as OQPSK.

GSM - This air interface is defined by the international standard Global System for Mobile Communications. Like TDMA, GSM is characterized by the use of both frequency and time separation. The channel bandwidth is 200 KHz, which is wider than the 30 KHz used  
10 for TDMA. Control channels are known as Standalone Dedicated Control Channels (SDCCH), and are transmitted in bursts in timeslots assigned for use by SDCCH. SDCCH may be assigned anywhere in the frequency band. Voice channels are known as Traffic Channels (TCH). SDCCH and TCH may occupy the same frequency assignments, but not the same timeslot assignment in a given frequency assignment. SDCCH and TCH use the  
15 same modulation scheme, known as GMSK.

Within this specification the reference to any one of the air interfaces shall automatically refer to all of the air interfaces, unless specified otherwise. Additionally, a reference to control channels or voice channels shall refer to all types of control or voice channels,  
20 whatever the preferred terminology for a particular air interface. Finally, there are many more types of air interfaces used throughout the world, and there is no intent to exclude any air interface from the inventive concepts described within this specification. Indeed, those skilled in the art will recognize other interfaces used elsewhere are derivatives of or similar in class to those described above.

25  
The preferred embodiments of the inventions disclosed herein have many advantages over other techniques for locating wireless telephones. For example, some of these other techniques involve adding GPS functionality to telephones, which requires that significant changes be made to the telephones. The preferred embodiments disclosed herein do not  
30 require any changes to wireless telephones, and so they can be used in connection with the current installed base of over 65 million wireless telephones in the U.S. and 250 million wireless telephones worldwide.

**SUMMARY OF THE INVENTION**

The present invention relates to an improved signal collection system (SCS) architecture for use in a Wireless Location System (WLS). The present invention provides reduced cost and improved performance in comparison to prior systems, such as those disclosed in 5 U.S. Patent Nos. 5,327,144 and 5,608,410. Aspects of the present invention include wideband energy detection and reporting, a protocol for efficiently setting levels for wideband energy detection, DSP sharing within an SCS, and recursive location processing using progressively greater bandwidth (i.e., more bits) from temporarily stored wideband 10 data.

The SCS's are designed to be reliable, efficient, and adaptable to meet the needs of a specific Wireless Location System implementation. In a presently preferred embodiment of the invention, each SCS comprises an antenna unit including one or more antennas, a 15 wideband receiver, a wideband energy detection unit, a memory for temporarily storing digital samples of received signals, a digital drop receiver, demodulation and normalization processors, a communications and control processor, and a high stability frequency reference.

20 The SCS operates to receive transmissions from mobile transmitters at unknown locations. Today's wireless communications systems typically employ three sectored cell sites with two antennae installed on each sector to provide for diversity against Rayleigh fading and multipath, and the SCS architecture supports this antenna configuration. Each SCS uses digital receivers to convert the RF transmissions from all antennas into separate digital 25 representations that are stored in memory. Energy detection is performed to determine the presence of a transmitted signal in the channels monitored by the SCS. Such energy detection is performed digitally (using algorithms in the digital signal processors) by periodically forming a map of the RCC spectrum and using channel energy estimates to determine when to demodulate signals within selected RCC's. The spectral map is 30 forwarded to a TDOA location processor (TLP). Each SCS also forwards identifying information about its received signals to an associated TLP and only forwards digital copies of signals that are of interest. When the TLP has determined that a signal of interest

is present in a particular channel from a particular antenna, it requests RF data for the appropriate channel and time period from the temporary memory associated with that antenna. The digital drop receiver within each SCS accesses the memory within that SCS, reads the requested RF data and extracts only the channel selected by the TLP.

5

The demodulation and normalization processors perform two principal operations on the digital data output by the digital drop receiver: (1) demodulation of signals on selected RCC's, so that the sampled bits are reduced in number (e.g., to provide a message of less than about 150 bits and containing the mobile transmitter's MIN, ESN, message type,  
10 dialed digits, and channel number); and (2) reduction of the number of bits per sample from the higher resolution of the receiver to the lower resolution required by the TLP.

The communications processor queues, prioritizes, and transmits traffic from the SCS to a TLP, the traffic including channel energy data, demodulated messages for selected RCC's,  
15 and RF data from the normalization processing.

The memory comprises a multi-port memory that can be read from at a higher rate than it is written to. This technique allows the SCS to use a common set of digital signal processors to perform the digital drop receiver, energy detection, demodulation, and  
20 normalization functions for all channels, all wideband receivers, and all antennae.

In addition, in the preferred embodiment the communications processor includes means for companding signals forwarded to the TLP, which permits the number of bits employed to represent values within a predetermined dynamic range to be reduced. Normally, a  
25 dynamic range of 84 dB requires 14 bits to fully represent and report each level. Using the companding technique, a predetermined dynamic range may be quantized, e.g., into 16 levels that are encoded into 4 bits, and the 4 bits may be assigned so as to optimize the performance of the system by maximizing the use of the available bandwidth. Further, the values for the companding may be automatically adjusted.

30

The many advantages offered by the present invention will be apparent to those skilled in the wireless location art. The described architecture represents an extremely low cost

architecture because of the use of common circuitry and processing to service all antennas and channel types (control and voice) at a particular antennae or cell site. In addition to the common processing circuitry, all receivers receive a common timing clock so that the same signal received on multiple antennae of an SCS are mixed using a clock of identical frequency and phase. This aids in later combining the signals at the SCS or the TLP for multipath processing. In this architecture, the TLP has the ability to request multiple copies of the same signal from multiple antennae at an SCS since each signal is separately stored.

10 Other details of the invention are described below.

#### **BRIEF DESCRIPTION OF THE DRAWINGS**

Figures 1 and 1A schematically depict a Wireless Location System in accordance with the present invention.

15

Figure 2 schematically depicts a Signal Collection System (SCS) 10 in accordance with the present invention.

Figure 2A schematically depicts a receiver module 10-2 employed by the Signal Collection System.

20

Figures 2B and 2C schematically depict alternative ways of coupling the receiver module(s) 10-2 to the antennas 10-1.

Figure 2C-1 is a flowchart of a process employed by the Wireless Location System when using narrowband receiver modules.

25

Figure 2D schematically depicts a DSP module 10-3 employed in the Signal Collection System in accordance with the present invention.

30

Figure 2E is a flowchart of the operation of the DSP module(s) 10-3, and Figure 2E-1 is a flowchart of the process employed by the DSP modules for detecting active channels.

Figure 2F schematically depicts a Control and Communications Module 10-5 in accordance with the present invention.

5     Figures 2G-2J depict aspects of the presently preferred SCS calibration methods. Figure 2G is a schematic illustration of baselines and error values used to explain an external calibration method in accordance with the present invention. Figure 2H is a flowchart of an internal calibration method. Figure 2I is an exemplary transfer function of an AMPS control channel and Figure 2J depicts an exemplary comb signal.

10

Figures 2K and 2L are flowcharts of two methods for monitoring performance of a Wireless Location System in accordance with the present invention.

15     Figure 3 schematically depicts a TDOA Location Processor 12 in accordance with the present invention.

Figure 3A depicts the structure of an exemplary network map maintained by the TLP controllers in accordance with the present invention.

20     Figures 4 and 4A schematically depict different aspects of an Applications Processor 14 in accordance with the present invention.

Figure 5 is a flowchart of a central station-based location processing method in accordance with the present invention.

25

Figure 6 is a flowchart of a station-based location processing method in accordance with the present invention.

30     Figure 7 is a flowchart of a method for determining, for each transmission for which a location is desired, whether to employ central or station-based processing.

Figure 8 is a flowchart of a dynamic process used to select cooperating antennas and SCS's 10 used in location processing.

5 Figure 9 is diagram that is referred to below in explaining a method for selecting a candidate list of SCS's and antennas using a predetermined set of criteria.

Figures 10A and 10B are flowcharts of alternative methods for increasing the bandwidth of a transmitted signal to improve location accuracy.

10 Figures 11A-11C are signal flow diagrams and Figure 11D is a flowchart, and they are used to explain an inventive method for combining multiple statistically independent location estimates to provide an estimate with improved accuracy.

15 Figures 12A and 12B are a block diagram and a graph, respectively, for explaining a bandwidth synthesis method.

#### **DETAILED DESCRIPTION OF PREFERRED EMBODIMENTS**

The Wireless Location System (Wireless Location System) operates as a passive overlay to a wireless communications system, such as a cellular, PCS, or ESMR system, although  
20 the concepts are not limited to just those types of communications systems. Wireless communications systems are generally not suitable for locating wireless devices because the designs of the wireless transmitters and cell sites do not include the necessary functionality to achieve accurate location. Accurate location in this application is defined as accuracy of 100 to 400 feet RMS (root mean square). This is distinguished from the  
25 location accuracy that can be achieved by existing cell sites, which is generally limited to the radius of the cell site. In general, cell sites are not designed or programmed to cooperate between and among themselves to determine wireless transmitter location. Additionally, wireless transmitters such as cellular and PCS telephones are designed to be low cost and therefore generally do not have locating capability built-in. The Wireless  
30 Location System is designed to be a low cost addition to a wireless communications system that involves minimal changes to cell sites and no changes at all to standard wireless transmitters. The Wireless Location System is passive because the it does not

contain transmitters, and therefore cannot cause interference of any kind to the wireless communications system. The Wireless Location System uses only its own specialized receivers at cell sites or other receiving locations.

5 Overview of Wireless Location System (Wireless Location System)

As shown in Figure 1, the Wireless Location System has four major kinds of subsystems: the Signal Collection Systems (SCS's) 10, the TDOA Location Processors (TLP's) 12, the Application Processors (AP's) 14, and the Network Operations Console (NOC) 16. Each SCS is responsible for receiving the RF signals transmitted by the wireless transmitters on both control channels and voice channels. In general, each SCS is preferably installed at a wireless carrier's cell site, and therefore operates in parallel to a base station. Each TLP 12 is responsible for managing a network of SCS's 10 and for providing a centralized pool of digital signal processing (DSP) resources that can be used in the location calculations. The SCS's 10 and the TLP's 12 operate together to determine the location of the wireless transmitters, as will be discussed more fully below. Digital signal processing is the preferable manner in which to process radio signals because DSP's are relatively low cost, provide consistent performance, and are easily re-programmable to handle many different tasks. Both the SCS's 10 and TLP's 12 contain a significant amount of DSP resources, and the software in these systems can operate dynamically to determine where to perform a particular processing function based upon tradeoffs in processing time, communications time, queuing time, and cost. Each TLP 12 exists centrally primarily to reduce the overall cost of implementing the Wireless Location System, although the techniques discussed herein are not limited to the preferred architecture shown. That is, DSP resources can be relocated within the Wireless Location System without changing the basic concepts and functionality disclosed.

The AP's 14 are responsible for managing all of the resources in the Wireless Location System, including all of the SCS's 10 and TLP's 12. Each AP 14 also contains a specialized database that contains "triggers" for the Wireless Location System. In order to conserve resources, the Wireless Location System can be programmed to locate only certain pre-determined types of transmissions. When a transmission of a pre-determined type occurs, then the Wireless Location System is triggered to begin location processing.



Otherwise, the Wireless Location System may be programmed to ignore the transmission. Each AP 14 also contains applications interfaces that permit a variety of applications to securely access the Wireless Location System. These applications may, for example, access location records in real time or non-real time, create or delete certain type of triggers, or cause the Wireless Location System to take other actions. Each AP 14 is also capable of certain post-processing functions that allow the AP 14 to combine a number of location records to generate extended reports or analyses useful for applications such as traffic monitoring or RF optimization.

10 The NOC 16 is a network management system that provides operators of the Wireless Location System easy access to the programming parameters of the Wireless Location System. For example, in some cities, the Wireless Location System may contain many hundreds or even thousands of SCS's 10. The NOC is the most effective way to manage a large Wireless Location System, using graphical user interface capabilities. The NOC will also receive real time alerts if certain functions within the Wireless Location System are not operating properly. These real time alerts can be used by the operator to take corrective action quickly and prevent a degradation of location service. Experience with trials of the Wireless Location System show that the ability of the system to maintain good location accuracy over time is directly related to the operator's ability to keep the system operating within its predetermined parameters.

Readers of U.S. Patents 5,327,144 and 5,608,410 and this specification will note similarities between the respective systems. Indeed, the system disclosed herein is significantly based upon and also significantly enhanced from the system described in those previous patents. For example, the SCS 10 has been expanded and enhanced from the Antenna Site System described in 5,608,410. The SCS 10 now has the capability to support many more antennas at a single cell site, and further can support the use of extended antennas as described below. This enables the SCS 10 to operate with the sectored cell sites now commonly used. The SCS 10 can also transfer data from multiple antennas at a cell site to the TLP 12 instead of always combining data from multiple antennas before transfer. Additionally, the SCS 10 can support multiple air interface

protocols thereby allowing the SCS 10 to function even as a wireless carrier continually changes the configuration of its system.

5 The TLP 12 is similar to the Central Site System disclosed in 5,608,410, but has also been expanded and enhanced. For example, the TLP 12 has been made scaleable so that the amount of DSP resources required by each TLP 12 can be appropriately scaled to match the number of locations per second required by customers of the Wireless Location System. In order to support scaling for different Wireless Location System capacities, a networking scheme has been added to the TLP 12 so that multiple TLP's 12 can cooperate  
10 to share RF data across wireless communication system network boundaries. Additionally, the TLP 12 has been given control means to determine the SCS's 10, and more importantly the antennas at each of the SCS's 10, from which the TLP 12 is to receive data in order to process a specific location. Previously, the Antenna Site Systems automatically forwarded data to the Central Site System, whether requested or not by the Central Site  
15 System. Furthermore, the SCS 10 and TLP 12 combined have been designed with additional means for removing multipath from the received transmissions.

The Database Subsystem of the Central Site System has been expanded and developed into the AP 14. The AP 14 can support a greater variety of applications than previously  
20 disclosed in 5,608,410, including the ability to post-process large volumes of location records from multiple wireless transmitters. This post-processed data can yield, for example, very effective maps for use by wireless carriers to improve and optimize the RF design of the communications systems. This can be achieved, for example, by plotting the locations of all of the callers in an area and the received signal strengths at a number of  
25 cell sites. The carrier can then determine whether each cell site is, in fact, serving the exact coverage area desired by the carrier. The AP 14 can also now store location records anonymously, that is, with the MIN and/or other identity information removed from the location record, so that the location record can be used for RF optimization or traffic monitoring without causing concerns about an individual user's privacy.

30 As shown in Figure 1A, a presently preferred implementation of the Wireless Location System includes a plurality of SCS regions each of which comprises multiple SCS's 10.

For example, "SCS Region 1" includes SCS's 10A and 10B (and preferably others, not shown) that are located at respective cell sites and share antennas with the base stations at those cell sites. Drop and insert units 11A and 11B are used to interface fractional T1/E1 lines to full T1/E1 lines, which in turn are coupled to a digital access and control system (DACS) 13A. The DACS 13A and another DACS 13B are used in the manner described more fully below for communications between the SCS's 10A, 10B, etc., and multiple TLP's 12A, 12B, etc. As shown, the TLP's are typically collocated and interconnected via an Ethernet network (backbone) and a second, redundant Ethernet network. Also coupled to the Ethernet networks are multiple AP's 14A and 14B, multiple NOC's 16A and 16B, and a terminal server 15. Routers 19A and 19B are used to couple one Wireless Location System to one or more other Wireless Location System(s).

#### Signal Collection System 10

Generally, cell sites will have one of the following antenna configurations: (i) an omnidirectional site with 1 or 2 receive antennas or (ii) a sectored site with 1, 2, or 3 sectors, and with 1 or 2 receive antennas used in each sector. As the number of cell sites has increased in the U.S. and internationally, sectored cell sites have become the predominant configuration. However, there are also a growing number of micro-cells and pico-cells, which can be omnidirectional. Therefore, the SCS 10 has been designed to be configurable for any of these typical cell sites and has been provided with mechanisms to employ any number of antennas at a cell site.

The basic architectural elements of the SCS 10 remain the same as for the Antenna Site System described in 5,608,410, but several enhancements have been made to increase the flexibility of the SCS 10 and to reduce the commercial deployment cost of the system. The most presently preferred embodiment of the SCS 10 is described herein. The SCS 10, an overview of which is shown in Figure 2, includes digital receiver modules 10-2A through 10-2C; DSP modules 10-3A through 10-3C; a serial bus 10-4, a control and communications module 10-5; a GPS module 10-6; and a clock distribution module 10-7. The SCS 10 has the following external connections: power, fractional T1/E1 communications, RF connections to antennas, and a GPS antenna connection for the timing generation (or clock distribution) module 10-7. The architecture and packaging of

the SCS 10 permit it to be physically collocated with cell sites (which is the most common installation place), located at other types of towers (such as FM, AM, two-way emergency communications, television, etc.), or located at other building structures (such as rooftops, silos, etc.).

5

#### Timing Generation

The Wireless Location System depends upon the accurate determination of time at all SCS's 10 contained within a network. Several different timing generation systems have been described in previous disclosures, however the most presently preferred embodiment is based upon an enhanced GPS receiver 10-6. The enhanced GPS receiver differs from most traditional GPS receivers in that the receiver contains algorithms that remove some of the timing instability of the GPS signals, and guarantees that any two SCS's 10 contained within a network can receive timing pulses that are within approximately ten nanoseconds of each other. These enhanced GPS receivers are now commercially available, and further reduce some of the time reference related errors that were observed in previous implementations of wireless location systems. While this enhanced GPS receiver can produce a very accurate time reference, the output of the receiver may still have an unacceptable phase noise. Therefore, the output of the receiver is input to a low phase noise, crystal oscillator-driven phase locked loop circuit that can now produce 10 MHz and one pulse per second (PPS) reference signals with less than 0.01 degrees RMS of phase noise, and with the pulse output at any SCS 10 in a Wireless Location System network within ten nanoseconds of any other pulse at another SCS 10. This combination of enhanced GPS receiver, crystal oscillator, and phase locked loop is now the most preferred method to produce stable time and frequency reference signals with low phase noise.

25

The SCS 10 has been designed to support multiple frequency bands and multiple carriers with equipment located at the same cell site. This can take place by using multiple receivers internal to a single SCS chassis, or by using multiple chassis each with separate receivers. In the event that multiple SCS chassis are placed at the same cell site, the SCS's 10 can share a single timing generation/clock distribution circuit 10-7 and thereby reduce overall system cost. The 10 MHz and one PPS output signals from the timing generation

30

circuit are amplified and buffered internal to the SCS 10, and then made available via external connectors. Therefore a second SCS can receive its timing from a first SCS using the buffered output and the external connectors. These signals can also be made available to base station equipment collocated at the cell site. This might be useful to the base station, for example, in improving the frequency re-use pattern of a wireless communications system.

#### Receiver Module 10-2 (Wideband Embodiment)

When a wireless transmitter makes a transmission, the Wireless Location System must receive the transmission at multiple SCS's 10 located at multiple geographically dispersed cell sites. Therefore, each SCS 10 has the ability to receive a transmission on any RF channel on which the transmission may originate. Additionally, since the SCS 10 is capable of supporting multiple air interface protocols, the SCS 10 also supports multiple types of RF channels. This is in contrast to most current base station receivers, which typically receive only one type of channel and are usually capable of receiving only on select RF channels at each cell site. For example, a typical TDMA base station receiver will only support 30 KHz wide channels, and each receiver is programmed to receive signals on only a single channel whose frequency does not change often (i.e. there is a relatively fixed frequency plan). Therefore, very few TDMA base station receivers would receive a transmission on any given frequency. As another example, even though some GSM base station receivers are capable of frequency hopping, the receivers at multiple base stations are generally not capable of simultaneously tuning to a single frequency for the purpose of performing location processing. In fact, the receivers at GSM base stations are programmed to frequency hop to avoid using an RF channel that is being used by another transmitter so as to minimize interference.

The SCS receiver module 10-2 is preferably a dual wideband digital receiver that can receive the entire frequency band and all of the RF channels of an air interface. For cellular systems in the U.S., this receiver module is either 15 MHz wide or 25 MHz wide so that all of the channels of a single carrier or all of the channels of both carriers can be received. This receiver module has many of the characteristics of the receiver previously described in Patent Number 5,608,410, and Figure 2A is a block diagram of the currently

preferred embodiment. Each receiver module contains an RF tuner section 10-2-1, a data interface and control section 10-2-2 and an analog to digital conversion section 10-2-3. The RF tuner section 10-2-1 includes two full independent digital receivers (including Tuner #1 and Tuner #2) that convert the analog RF input from an external connector into a digitized data stream. Unlike most base station receivers, the SCS receiver module does not perform diversity combining or switching. Rather, the digitized signal from each independent receiver is made available to the location processing. The present inventors have determined that there is an advantage to the location processing, and especially the multipath mitigation processing, to independently process the signals from each antenna rather than perform combining on the receiver module.

The receiver module 10-2 performs, or is coupled to elements that perform, the following functions: automatic gain control (to support both nearby strong signals and far away weak signals), bandpass filtering to remove potentially interfering signals from outside of the RF band of interest, synthesis of frequencies needed for mixing with the RF signals to create an IF signal that can be sampled, mixing, and analog to digital conversion (ADC) for sampling the RF signals and outputting a digitized data stream having an appropriate bandwidth and bit resolution. The frequency synthesizer locks the synthesized frequencies to the 10 MHz reference signal from the clock distribution/timing generation module 10-7 (Figure 2). All of the circuits used in the receiver module maintain the low phase noise characteristics of the timing reference signal. The receiver module preferably has a spurious free dynamic range of at least 80 dB.

The receiver module 10-2 also contains circuits to generate test frequencies and calibration signals, as well as test ports where measurements can be made by technicians during installation or troubleshooting. Various calibration processes are described in further detail below. The internally generated test frequencies and test ports provide an easy method for engineers and technicians to rapidly test the receiver module and diagnose any suspected problems. This is also especially useful during the manufacturing process.

One of the advantages of the Wireless Location System described herein is that no new antennas are required at cell sites. The Wireless Location System can use the existing

antennas already installed at most cell sites, including both omni-directional and sectored antennas. This feature can result in significant savings in the installation and maintenance costs of the Wireless Location System versus other approaches that have been described in the prior art. The SCS's digital receivers 10-2 can be connected to the existing antennas in two ways, as shown in Figures 2B and 2C, respectively. In Figure 2B, the SCS receivers 10-2 are connected to the existing cell site multi-coupler or RF splitter. In this manner, the SCS 10 uses the cell site's existing low noise pre-amplifier, band pass filter, and multi-coupler or RF splitter. This type of connection usually limits the SCS 10 to supporting the frequency band of a single carrier. For example, an A-side cellular carrier will typically use the band pass filter to block signals from customers of the B-side carrier, and vice versa.

In Figure 2C, the existing RF path at the cell site has been interrupted, and a new pre-amplifier, band pass filter, and RF splitter has been added as part of the Wireless Location System. The new band pass filter will pass multiple contiguous frequency bands, such as both the A-side and B-side cellular carriers, thereby allowing the Wireless Location System to locate wireless transmitters using both cellular systems but using the antennas from a single cell site. In this configuration, the Wireless Location System uses matched RF components at each cell site, so that the phase versus frequency responses are identical. This is in contrast to existing RF components, which may be from different manufacturers or using different model numbers at various cell sites. Matching the response characteristics of RF components reduces a possible source of error for the location processing, although the Wireless Location System has the capability to compensate for these sources of error. Finally, the new pre-amplifier installed with the Wireless Location System will have a very low noise figure to improve the sensitivity of the SCS 10 at a cell site. The overall noise figure of the SCS digital receivers 10-2 is dominated by the noise figure of the low noise amplifiers. Because the Wireless Location System can use weak signals in location processing, whereas the base station typically cannot process weak signals, the Wireless Location System can significantly benefit from a high quality, very low noise amplifier.

In order to improve the ability of the Wireless Location System to accurately determine TDOA for a wireless transmission, the phase versus frequency response of the cell site's RF components are determined at the time of installation and updated at other certain times and then stored in a table in the Wireless Location System. This can be important  
5 because, for example, the band pass filters and/or multi-couplers made by some manufacturers have a steep and non-linear phase versus frequency response near the edge of the pass band. If the edge of the pass band is very near to or coincident with the reverse control or voice channels, then the Wireless Location System would make incorrect measurements of the transmitted signal's phase characteristics if the Wireless Location  
10 System did not correct the measurements using the stored characteristics. This becomes even more important if a carrier has installed multi-couplers and/or band pass filters from more than one manufacturer, because the characteristics at each site may be different. In addition to measuring the phase versus frequency response, other environmental factors may cause changes to the RF path prior to the ADC. These factors require occasional and  
15 sometimes periodic calibration in the SCS 10.

#### Alternative Narrowband Embodiment of Receiver Module 10-2

In addition or as an alternative to the wideband receiver module, the SCS 10 also supports a narrowband embodiment of the receiver module 10-2. In contrast to the wideband  
20 receiver module that can simultaneously receive all of the RF channels in use by a wireless communications system, the narrowband receiver can only receive one or a few RF channels at a time. For example, the SCS 10 supports a 60 KHz narrowband receiver for use in AMPS/TDMA systems, covering two contiguous 30 KHz channels. This receiver is still a digital receiver as described for the wideband module, however the frequency  
25 synthesizing and mixing circuits are used to dynamically tune the receiver module to various RF channels on command. This dynamic tuning can typically occur in one millisecond or less, and the receiver can dwell on a specific RF channel for as long as required to receive and digitize RF data for location processing.

30 The purpose of the narrowband receiver is to reduce the implementation cost of a Wireless Location System from the cost that is incurred with wideband receivers. Of course, there is some loss of performance, but the availability of these multiple receivers permits wireless



- carriers to have more cost/performance options. Additional inventive functions and enhancements have been added to the Wireless Location System to support this new type of narrowband receiver. When the wideband receiver is being used, all RF channels are received continuously at all SCS's 10, and subsequent to the transmission, the Wireless
- 5 Location System can use the DSP's 10-3 (Figure 2) to dynamically select any RF channel from the digital memory. With the narrowband receiver, the Wireless Location System must ensure *a priori* that the narrowband receivers at multiple cell sites are simultaneously tuned to the same RF channel so that all receivers can simultaneously receive, digitize and store the same wireless transmission. For this reason, the narrowband receiver is generally
- 10 used only for locating voice channel transmissions, which can be known *a priori* to be making a transmission. Since control channel transmissions can occur asynchronously at any time, the narrowband receiver may not be tuned to the correct channel to receive the transmission.
- 15 When the narrowband receivers are used for locating AMPS voice channel transmissions, the Wireless Location System has the ability to temporarily change the modulation characteristics of the AMPS wireless transmitter to aid location processing. This may be necessary because AMPS voice channels are only FM modulated with the addition of a low level supervisory tone known as SAT. As is known in the art, the Cramer-Rao lower
- 20 bound of AMPS FM modulation is significantly worse than the Manchester encoded FSK modulation used for AMPS reverse channels and "blank and burst" transmissions on the voice channel. Further, AMPS wireless transmitters may be transmitting with significantly reduced energy if there is no modulating input signal (i.e., no one is speaking). To improve the location estimate by improving the modulation characteristics without depending on
- 25 the existence or amplitude of an input modulating signal, the Wireless Location System can cause an AMPS wireless transmitter to transmit a "blank and burst" message at a point in time when the narrowband receivers at multiple SCS's 10 are tuned to the RF channel on which the message will be sent. This is further described later.
- 30 The Wireless Location System performs the following steps when using the narrowband receiver module (see the flowchart of Figure 2C-1):

a first wireless transmitter is *a priori* engaged in transmitting on a particular RF channel;

the Wireless Location System triggers to make a location estimate of the first wireless transmitter (the trigger may occur either internally or externally via a command/response interface);

5 the Wireless Location System determines the cell site, sector, RF channel, timeslot, long code mask, and encryption key (all information elements may not be necessary for all air interface protocols) currently in use by the first wireless transmitter;

10 the Wireless Location System tunes an appropriate first narrowband receiver at an appropriate first SCS 10 to the RF channel and timeslot at the designated cell site and sector, where appropriate typically means both available and collocated or in closest proximity;

15 the first SCS 10 receives a time segment of RF data, typically ranging from a few microseconds to tens of milliseconds, from the first narrowband receiver and evaluates the transmission's power, SNR, and modulation characteristics;

if the transmission's power or SNR is below a predetermined threshold, the Wireless Location System waits a predetermined length of time and then returns to the above third step (where the Wireless Location System determines the cell site, sector, etc.);

20 if the transmission is an AMPS voice channel transmission and the modulation is below a threshold, then the Wireless Location System commands the wireless communications system to send a command to the first wireless transmitter to cause a "blank and burst" on the first wireless transmitter;

25 the Wireless Location System requests the wireless communications system to prevent hand-off of the wireless transmitter to another RF channel for a predetermined length of time;

the Wireless Location System receives a response from the wireless communications system indicating the time period during which the first wireless transmitter will be prevented from handing-off, and if commanded, the time period during which the wireless communications system will send a command to the first wireless transmitter to cause a "blank and burst";

30

the Wireless Location System determines the list of antennas that will be used in location processing (the antenna selection process is described below);

the Wireless Location System determines the earliest Wireless Location System timestamp at which the narrowband receivers connected to the selected antennas are available to begin simultaneously collecting RF data from the RF channel currently in use by the first wireless transmitter;

based upon the earliest Wireless Location System timestamp and the time periods in the response from the wireless communications system, the Wireless Location System commands the narrowband receivers connected to the antennas that will be used in location processing to tune to the cell site, sector, and RF channel currently in use by the first wireless transmitter and to receive RF data for a predetermined dwell time (based upon the bandwidth of the signal, SNR, and integration requirements);

the RF data received by the narrowband receivers are written into the dual port memory;

location processing on the received RF data commences, as described in Patent Nos. 5,327,144 and 5,608,410 and in sections below;

the Wireless Location System again determines the cell site, sector, RF channel, timeslot, long code mask, and encryption key currently in use by the first wireless transmitter;

if the cell site, sector, RF channel, timeslot, long code mask, and encryption key currently in use by the first wireless transmitter has changed between queries (i.e. before and after gathering the RF data) the Wireless Location System ceases location processing, causes an alert message that location processing failed because the wireless transmitter changed transmission status during the period of time in which RF data was being received, and re-triggers this entire process;

location processing on the received RF data completes in accordance with the steps described below.

30 The determination of the information elements including cell site, sector, RF channel, timeslot, long code mask, and encryption key (all information elements may not be necessary for all air interface protocols) is typically obtained by the Wireless Location

System through a command / response interface between the Wireless Location System and the wireless communications system.

5 The use of the narrowband receiver in the manner described above is known as random tuning because the receivers can be directed to any RF channel on command from the system. One advantage to random tuning is that locations are processed only for those wireless transmitters for which the Wireless Location System is triggered. One disadvantage to random tuning is that various synchronization factors, including the interface between the wireless communications system and the Wireless Location System and the latency times in scheduling the necessary receivers throughout the system, can limit the total location processing throughput. For example, in a TDMA system, random tuning used throughout the Wireless Location System will typically limit location processing throughput to about 2.5 locations per second per cell site sector.

15 Therefore, the narrowband receiver also supports another mode, known as automatic sequential tuning, which can perform location processing at a higher throughput. For example, in a TDMA system, using similar assumptions about dwell time and setup time as for the narrowband receiver operation described above, sequential tuning can achieve a location processing throughput of about 41 locations per second per cell site sector, meaning that all 395 TDMA RF channels can be processed in about 9 seconds. This increased rate can be achieved by taking advantage of, for example, the two contiguous RF channels that can be received simultaneously, location processing all three TDMA timeslots in an RF channel, and eliminating the need for synchronization with the wireless communications system. When the Wireless Location System is using the narrowband receivers for sequential tuning, the Wireless Location System has no knowledge of the identity of the wireless transmitter because the Wireless Location System does not wait for a trigger, nor does the Wireless Location System query the wireless communications system for the identity information prior to receiving the transmission. In this method, the Wireless Location System sequences through every cell site, RF channel and time slot, performs location processing, and reports a location record identifying a time stamp, cell site, RF channel, time slot, and location. Subsequent to the location record report, the Wireless Location System and the wireless communications system match the location

records to the wireless communications system's data indicating which wireless transmitters were in use at the time, and which cell sites, RF channels, and time slots were used by each wireless transmitter. Then, the Wireless Location System can retain the location records for wireless transmitters of interest, and discard those location records for  
5 the remaining wireless transmitters.

#### Digital Signal Processor Module 10-3

The SCS digital receiver modules 10-2 output a digitized RF data stream having a specified bandwidth and bit resolution. For example, a 15 MHz embodiment of the  
10 wideband receiver may output a data stream containing 60 million samples per second, at a resolution of 14 bits per sample. This RF data stream will contain all of the RF channels that are used by the wireless communications system. The DSP modules 10-3 receive the digitized data stream, and can extract any individual RF channel through digital mixing and filtering. The DSP's can also reduce the bit resolution upon command from the  
15 Wireless Location System, as needed to reduce the bandwidth requirements between the SCS 10 and TLP 12. The Wireless Location System can dynamically select the bit resolution at which to forward digitized baseband RF data, based upon the processing requirements for each location. DSP's are used for these functions to reduce the systemic errors that can occur from mixing and filtering with analog components. The use of DSP's  
20 allows perfect matching in the processing between any two SCS's 10.

A block diagram of the DSP module 10-3 is shown in Figure 2D, and the operation of the DSP module is depicted by the flowchart of Figure 2E. As shown in Figure 2D, the DSP module 10-3 comprises the following elements: a pair of DSP elements 10-3-1A and 10-3-  
25 1B, referred to collectively as a "first" DSP; serial to parallel converters 10-3-2; dual port memory elements 10-3-3; a second DSP 10-3-4; a parallel to serial converter; a FIFO buffer; a DSP 10-3-5 (including RAM) for detection, another DSP 10-3-6 for demodulation, and another DSP 10-3-7 for normalization and control; and an address generator 10-3-8. In a presently preferred embodiment, the DSP module 10-3 receives the  
30 wideband digitized data stream (Figure 2E, step S1), and uses the first DSP (10-3-1A and 10-3-1B) to extract blocks of channels (step S2). For example, a first DSP programmed to operate as a digital drop receiver can extract four blocks of channels, where each block

includes at least 1.25 MHz of bandwidth. This bandwidth can include 42 channels of AMPS or TDMA, 6 channels of GSM, or 1 channel of CDMA. The DSP does not require the blocks to be contiguous, as the DSP can independently digitally tune to any set of RF channels within the bandwidth of the wideband digitized data stream. The DSP can also

5 perform wideband or narrow band energy detection on all or any of the channels in the block, and report the power levels by channel to the TLP 12 (step S3). For example, every 10 ms, the DSP can perform wideband energy detection and create an RF spectral map for all channels for all receivers (see step S9). Because this spectral map can be sent from the SCS 10 to the TLP 12 every 10 ms via the communications link connecting the SCS 10

10 and the TLP 12, a significant data overhead could exist. Therefore, the DSP reduces the data overhead by companding the data into a finite number of levels. Normally, for example, 84 dB of dynamic range could require 14 bits. In the companding process implemented by the DSP, the data is reduced, for example, to only 4 bits by selecting 16 important RF spectral levels to send to the TLP 12. The choice of the number of levels,

15 and therefore the number of bits, as well as the representation of the levels, can be automatically adjusted by the Wireless Location System. These adjustments are performed to maximize the information value of the RF spectral messages sent to the TLP 12 as well as to optimize the use of the bandwidth available on the communications link between the SCS 10 and the TLP 12.

20

After conversion, each block of RF channels (each at least 1.25 MHz) is passed through serial to parallel converter 10-3-2 and then stored in dual port digital memory 10-3-3 (step S4). The digital memory is a circular memory, which means that the DSP module begins writing data into the first memory address and then continues sequentially until the last

25 memory address is reached. When the last memory address is reached, the DSP returns to the first memory address and continues to sequentially write data into memory. Each DSP module typically contains enough memory to store several seconds of data for each block of RF channels to support the latency and queuing times in the location process.

30 In the DSP module, the memory address at which digitized and converted RF data is written into memory is the time stamp used throughout the Wireless Location System and which the location processing references in determining TDOA. In order to ensure that the

time stamps are aligned at every SCS 10 in the Wireless Location System, the address generator 10-3-8 receives the one pulse per second signal from the timing generation/clock distribution module 10-7 (Figure 2). Periodically, the address generator at all SCS's 10 in a Wireless Location System will simultaneously reset themselves to a known address. This  
5 enables the location processing to reduce or eliminate accumulated timing errors in the recording of time stamps for each digitized data element.

The address generator 10-3-8 controls both writing to and reading from the dual port digital memory 10-3-3. Writing takes places continuously since the ADC is continuously  
10 sampling and digitizing RF signals and the first DSP (10-3-1A and 10-3-1B) is continuously performing the digital drop receiver function. However, reading occurs in bursts as the Wireless Location System requests data for performing demodulation and location processing. The Wireless Location System may even perform location processing recursively on a single transmission, and therefore requires access to the same data  
15 multiple times. In order to service the many requirements of the Wireless Location System, the address generator allows the dual port digital memory to be read at a rate faster than the writing occurs. Typically, reading can be performed eight times faster than writing.

20 The DSP module 10-3 uses the second DSP 10-3-4 to read the data from the digital memory 10-3-3, and then performs a second digital drop receiver function to extract baseband data from the blocks of RF channels (step S5). For example, the second DSP can extract any single 30 KHz AMPS or TDMA channel from any block of RF channels that have been digitized and stored in the memory. Likewise, the second DSP can extract any  
25 single GSM channel. The second DSP is not required to extract a CDMA channel, since the channel bandwidth occupies the full bandwidth of the stored RF data. The combination of the first DSP 10-3-1A, 10-3-1B and the second DSP 10-3-4 allows the DSP module to select, store, and recover any single RF channel in a wireless communications system. A DSP module typically will store four blocks of channels. In a dual-mode AMPS/TDMA  
30 system, a single DSP module can continuously and simultaneously monitor up to 42 analog reverse control channels, up to 84 digital control channels, and also be tasked to monitor and locate any voice channel transmission. A single SCS chassis will typically

support up to three receiver modules 10-2 (Figure 2), to cover three sectors of two antennas each, and up to nine DSP modules (three DSP modules per receiver permits an entire 15 MHz bandwidth to be simultaneously stored into digital memory). Thus, the SCS 10 is a very modular system than can be easily scaled to match any type of cell site  
5 configuration and processing load.

The DSP module 10-3 also performs other functions, including automatic detection of active channels used in each sector (step S6), demodulation (step S7), and station based location processing (step S8). The Wireless Location System maintains an active map of  
10 the usage of the RF channels in a wireless communications system (step S9), which enables the Wireless Location System to manage receiver and processing resources, and to rapidly initiate processing when a particular transmission of interest has occurred. The active map comprises a table maintained within the Wireless Location System that lists for each antenna connected to an SCS 10 the primary channels assigned to that SCS 10 and  
15 the protocols used in those channels. A primary channel is an RF control channel assigned to a collocated or nearby base station which the base station uses for communications with wireless transmitters. For example, in a typical cellular system with sectored cell sites, there will be one RF control channel frequency assigned for use in each sector. Those control channel frequencies would typically be assigned as primary channels for a  
20 collocated SCS 10.

The same SCS 10 may also be assigned to monitor the RF control channels of other nearby base stations as primary channels, even if other SCS's 10 also have the same primary channels assigned. In this manner, the Wireless Location System implements a  
25 system demodulation redundancy that ensures that any given wireless transmission has an infinitesimal probability of being missed. When this demodulation redundancy feature is used, the Wireless Location System will receive, detect, and demodulate the same wireless transmission two or more times at more than one SCS 10. The Wireless Location System includes means to detect when this multiple demodulation has occurred and to trigger  
30 location processing only once. This function conserves the processing and communications resources of the Wireless Location System, and is further described below. This ability for a single SCS 10 to detect and demodulate wireless transmissions



occurring at cell sites not collocated with the SCS 10 permits operators of the Wireless Location System to deploy more efficient Wireless Location System networks. For example, the Wireless Location System may be designed such that the Wireless Location System uses much fewer SCS's 10 than the wireless communications system has base stations.

In the Wireless Location System, primary channels are entered and maintained in the table using two methods: direct programming and automatic detection. Direct programming comprises entering primary channel data into the table using one of the Wireless Location System user interfaces, such as the Network Operations Console 16 (Figure 1), or by receiving channel assignment data from the Wireless Location System to wireless communications system interface. Alternatively, the DSP module 10-3 also runs a background process known as automatic detection in which the DSP uses spare or scheduled processing capacity to detect transmissions on various possible RF channels and then attempt to demodulate those transmissions using probable protocols. The DSP module can then confirm that the primary channels directly programmed are correct, and can also quickly detect changes made to channels at base station and send an alert to the operator of the Wireless Location System.

The DSP module performs the following steps in automatic detection (see Figure 2E-1):

- for each possible control and/or voice channel which may be used in the coverage area of the SCS 10, peg counters are established (step S7-1);
- at the start of a detection period, all peg counters are reset to zero (step S7-2);
- each time that a transmission occurs in a specified RF channel, and the received power level is above a particular pre-set threshold, the peg counter for that channel is incremented (step S7-3);
- each time that a transmission occurs in a specified RF channel, and the received power level is above a second particular pre-set threshold, the DSP module attempts to demodulate a certain portion of the transmission using a first preferred protocol (step S7-4);
- if the demodulation is successful, a second peg counter for that channel is incremented (step S7-5);

- if the demodulation is unsuccessful, the DSP module attempts to demodulate a portion of the transmission using a second preferred protocol (step S7-6);  
if the demodulation is successful, a third peg counter for that channel is incremented (step S7-7);  
5 at the end of a detection period, the Wireless Location System reads all peg counters (step S7-8); and  
the Wireless Location System automatically assigns primary channels based upon the peg counters (step S7-9).
- 10 The operator of the Wireless Location System can review the peg counters and the automatic assignment of primary channels and demodulation protocols, and override any settings that were performed automatically. In addition, if more than two preferred protocols may be used by the wireless carrier, then the DSP module 10-3 can be downloaded with software to detect the additional protocols. The architecture of the SCS  
15 10, based upon wideband receivers 10-2, DSP modules 10-3, and downloadable software permits the Wireless Location System to support multiple demodulation protocols in a single system. There is a significant cost advantage to supporting multiple protocols within the single system, as only a single SCS 10 is required at a cell site. This is in contrast to many base station architectures, which may require different transceiver modules for  
20 different modulation protocols. For example, while the SCS 10 could support AMPS, TDMA, and CDMA simultaneously in the same SCS 10, there is no base station currently available that can support this functionality.

The ability to detect and demodulate multiple protocols also includes the ability to  
25 independently detect the use of authentication in messages transmitted over the certain air interface protocols. The use of authentication fields in wireless transmitters started to become prevalent within the last few years as a means to reduce the occurrence of fraud in wireless communications systems. However, not all wireless transmitters have implemented authentication. When authentication is used, the protocol generally inserts an  
30 additional field into the transmitted message. Frequently this field is inserted between the identity of the wireless transmitter and the dialed digits in the transmitted message. When demodulating a wireless transmission, the Wireless Location System determines the

number of fields in the transmitted message, as well as the message type (i.e. registration, origination, page response, etc.). The Wireless Location System demodulates all fields and if extra fields appear to be present, giving consideration to the type of message transmitted, then the Wireless Location System tests all fields for a trigger condition. For example, if the dialed digits "911" appear in the proper place in a field, and the field is located either in its proper place without authentication or its proper place with authentication, then the Wireless Location System triggers normally. In this example, the digits "911" would be required to appear in sequence as "911" or "\*911", with no other digits before or after either sequence. This functionality reduces or eliminates a false trigger caused by the digits "911" appearing as part of an authentication field.

The support for multiple demodulation protocols is important for the Wireless Location System to successfully operate because location processing must be quickly triggered when a wireless caller has dialed "911". The Wireless Location System can trigger location processing using two methods: the Wireless Location System will independently demodulate control channel transmissions, and trigger location processing using any number of criteria such as dialed digits, or the Wireless Location System may receive triggers from an external source such as the carrier's wireless communications system. The present inventors have found that independent demodulation by the SCS 10 results in the fastest time to trigger, as measured from the moment that a wireless user presses the "SEND" or "TALK" (or similar) button on a wireless transmitter.

#### Control and Communications Module 10-5

The control and communications module 10-5, depicted in Figure 2F, includes data buffers 10-5-1, a controller 10-5-2, memory 10-5-3, a CPU 10-5-4 and a T1/E1 communications chip 10-5-5. The module has many of the characteristics previously described in Patent Number 5,608,410. Several enhancements have been added in the present embodiment. For example, the SCS 10 now includes an automatic remote reset capability, even if the CPU on the control and communications module ceases to execute its programmed software. This capability can reduce the operating costs of the Wireless Location System because technicians are not required to travel to a cell site to reset an SCS 10 if it fails to operate normally. The automatic remote reset circuit operates by

monitoring the communications interface between the SCS 10 and the TLP 12 for a particular sequence of bits. This sequence of bits is a sequence that does not occur during normal communications between the SCS 10 and the TLP 12. This sequence, for example, may consist of an all ones pattern. The reset circuit operates independently of the CPU so that even if the CPU has placed itself in a locked or other non-operating status, the circuit can still achieve the reset of the SCS 10 and return the CPU to an operating status.

This module now also has the ability to record and report a wide variety of statistics and variables used in monitoring or diagnosing the performance of the SCS 10. For example, the SCS 10 can monitor the percent capacity usage of any DSP or other processor in the SCS 10, as well as the communications interface between the SCS 10 and the TLP 12. These values are reported regularly to the AP 14 and the NOC 16, and are used to determine when additional processing and communications resources are required in the system. For example, alarm thresholds may be set in the NOC to indicate to an operator if any resource is consistently exceeding a preset threshold. The SCS 10 can also monitor the number of times that transmissions have been successfully demodulated, as well as the number of failures. This is useful in allowing operators to determine whether the signal thresholds for demodulation have been set optimally.

This module, as well as the other modules, can also self-report its identity to the TLP 12. As described below, many SCS's 10 can be connected to a single TLP 12. Typically, the communications between SCS's 10 and TLP's 12 is shared with the communications between base stations and MSC's. It is frequently difficult to quickly determine exactly which SCS's 10 have been assigned to particular circuits. Therefore, the SCS 10 contains a hard coded identity, which is recorded at the time of installation. This identity can be read and verified by the TLP 12 to positively determine which SCS 10 has been assigned by a carrier to each of several different communications circuits.

The SCS to TLP communications supports a variety of messages, including: commands and responses, software download, status and heartbeat, parameter download, diagnostic, spectral data, phase data, primary channel demodulation, and RF data. The communications protocol is designed to optimize Wireless Location System operation by

minimizing the protocol overhead and the protocol includes a message priority scheme. Each message type is assigned a priority, and the SCS 10 and the TLP 12 will queue messages by priority such that a higher priority message is sent before a lower priority message is sent. For example, demodulation messages are generally set at a high priority because the Wireless Location System must trigger location processing on certain types of calls (i.e., E9-1-1) without delay. Although higher priority messages are queued before lower priority messages, the protocol generally does not preempt a message that is already in transit. That is, a message in the process of being sent across the SCS 10 to TLP 12 communications interface will be completed fully, but then the next message to be sent will be the highest priority message with the earliest time stamp. In order to minimize the latency of high priority messages, long messages, such as RF data, are sent in segments. For example, the RF data for a full 100-millisecond AMPS transmission may be separated into 10-millisecond segments. In this manner, a high priority message may be queued in between segments of the RF data.

15

#### Calibration and Performance Monitoring

The architecture of the SCS 10 is heavily based upon digital technologies including the digital receiver and the digital signal processors. Once RF signals have been digitized, timing, frequency, and phase differences can be carefully controlled in the various processes. More importantly, any timing, frequency, and phase differences can be perfectly matched between the various receivers and various SCS's 10 used in the Wireless Location System. However, prior to the ADC, the RF signals pass through a number of RF components, including antennas, cables, low noise amplifiers, filters, duplexors, multi-couplers, and RF splitters. Each of these RF components has characteristics important to the Wireless Location System, including delay and phase versus frequency response. When the RF and analog components are perfectly matched between the pairs of SCS's 10, such as SCS 10A and SCS 10B in Figure 2G, then the effects of these characteristics are automatically eliminated in the location processing. But when the characteristics of the components are not matched, then the location processing can inadvertently include instrumental errors resulting from the mismatch. Additionally, many of these RF components can experience instability with power, time, temperature, or other factors that can add instrumental errors to the determination of location. Therefore,

30

several inventive techniques have been developed to calibrate the RF components in the Wireless Location System and to monitor the performance of the Wireless Location System on a regular basis. Subsequent to calibration, the Wireless Location System stores the values of these delays and phases versus frequency response (i.e. by RF channel number) in a table in the Wireless Location System for use in correcting these instrumental errors. Figures 2G-2J are referred to below in explaining these calibration methods.

#### External Calibration Method

Referring to Figure 2G, the timing stability of the Wireless Location System is measured along baselines, where each baseline is comprised of two SCS's, 10A and 10B, and an imaginary line (A - B) drawn between them. In a TDOA / FDOA type of Wireless Location System, locations of wireless transmitters are calculated by measuring the differences in the times that each SCS 10 records for the arrival of the signal from a wireless transmitter. Thus, it is important that the differences in times measured by SCS's 10 along any baseline are largely attributed to the transmission time of the signal from the wireless transmitter and minimally attributed to the variations in the RF and analog components of the SCS's 10 themselves. To meet the accuracy goals of the Wireless Location System, the timing stability for any pair of SCS's 10 are maintained at much less than 100 nanoseconds RMS (root mean square). Thus, the components of the Wireless Location System will contribute less than 100 feet RMS of instrumentation error in the estimation of the location of a wireless transmitter. Some of this error is allocated to the ambiguity of the signal used to calibrate the system. This ambiguity can be determined from the well-known Cramer-Rao lower bound equation. In the case of an AMPS reverse control channel, this error is approximately 40 nanoseconds RMS. The remainder of the error budget is allocated to the components of the Wireless Location System, primarily the RF and analog components in the SCS 10.

In the external calibration method, the Wireless Location System uses a network of calibration transmitters whose signal characteristics match those of the target wireless transmitters. These calibration transmitters may be ordinary wireless telephones emitting periodic registration signals and/or page response signals. Each usable SCS-to-SCS

baseline is preferably calibrated periodically using a calibration transmitter that has a relatively clear and unobstructed path to both SCS's 10 associated with the baseline. The calibration signal is processed identically to a signal from a target wireless transmitter. Since the TDOA values are known *a priori*, any errors in the calculations are due to systemic errors in the Wireless Location System. These systemic errors can then be removed in the subsequent location calculations for target transmitters.

Figure 2G illustrates the external calibration method for minimizing timing errors. As shown, a first SCS 10A at a point "A" and a second SCS 10A at a point "B" have an associated baseline A-B. A calibration signal emitted at time  $T_0$  by a calibration transmitter at point "C" will theoretically reach first SCS 10A at time  $T_0 + T_{AC}$ .  $T_{AC}$  is a measure of the amount of time required for the calibration signal to travel from the antenna on the calibration transmitter to the dual port digital memory in a digital receiver. Likewise, the same calibration signal will reach second SCS 10B at a theoretical time  $T_0 + T_{BC}$ . Usually, however, the calibration signal will not reach the digital memory and the digital signal processing components of the respective SCS's 10 at exactly the correct times. Rather, there will be errors  $e_1$  and  $e_2$  in the amount of time ( $T_{AC}$ ,  $T_{BC}$ ) it takes the calibration signal to propagate from the calibration transmitter to the SCS's 10, respectively, such that the exact times of arrival are actually  $T_0 + T_{AC} + e_1$  and  $T_0 + T_{BC} + e_2$ . Such errors will be due to some extent to delays in the signal propagation through the air, i.e., from the calibration transmitter's antenna to the SCS antennas; however, the errors will be due primarily to time varying characteristics in the SCS front end components. The errors  $e_1$  and  $e_2$  cannot be determined *per se* because the system does not know the exact time ( $T_0$ ) at which the calibration signal was transmitted. The system can, however, determine the error in the *difference* in the time of arrival of the calibration signal at the respective SCS's 10 of any given pair of SCS's 10. This TDOA error value is defined as the difference between the measured TDOA value and the theoretical TDOA value  $\tau_0$ , where  $\tau_0$  is the theoretical differences between the theoretical delay values  $T_{AC}$  and  $T_{BC}$ . Theoretical TDOA values for each pair of SCS's 10 and each calibration transmitter are known because the positions of the SCS's 10 and calibration transmitter, and the speed at which the calibration signal propagates, are known. The measured TDOA baseline ( $TDOA_{A-B}$ ) can be represented as  $TDOA_{A-B} = \tau_0 + \epsilon$ , where  $\epsilon = e_1 - e_2$ . In a

similar manner, a calibration signal from a second calibration transmitter at point "D" will have associated errors  $e_3$  and  $e_4$ . The ultimate value of  $\epsilon$  to be subtracted from TDOA measurements for a target transmitter will be a function (e.g., weighted average) of the  $\epsilon$  values derived for one or more calibration transmitters. Therefore, a given TDOA measurement (TDOA<sub>measured</sub>) for a pair of SCS's 10 at points "X" and "Y" and a target wireless transmitter at an unknown location will be corrected as follows:

$$\begin{aligned} \text{TDOA}_{X-Y} &= \text{TDOA}_{\text{measured}} - \epsilon \\ \epsilon &= k_1\epsilon_1 + k_2\epsilon_2 + \dots + k_N\epsilon_N, \end{aligned}$$

10

where  $k_1, k_2$ , etc., are weighting factors and  $\epsilon_1, \epsilon_2$ , etc., are the errors determined by subtracting the measured TDOA values from the theoretical values for each calibration transmitter. In this example, error value  $\epsilon_1$  may be the error value associated with the calibration transmitter at point "C" in the drawing. The weighting factors are determined by the operator of the Wireless Location System, and input into the configuration tables for each baseline. The operator will take into consideration the distance from each calibration transmitter to the SCS's 10 at points "X" and "Y", the empirically determined line of sight from each calibration transmitter to the SCS's 10 at points "X" and "Y", and the contribution that each SCS "X" and "Y" would have made to a location estimate of a wireless transmitter that might be located in the vicinity of each calibration transmitter. In general, calibration transmitters that are nearer to the SCS's 10 at points "X" and "Y" will be weighted higher than calibration transmitters that are farther away, and calibration transmitters with better line of sight to the SCS's 10 at points "X" and "Y" will be weighted higher than calibration transmitters with worse line of sight.

25

Each error component  $\epsilon_1, \epsilon_2$ , etc., and therefore the resulting error component  $\epsilon$ , can vary widely, and wildly, over time because some of the error component is due to multipath reflection from the calibration transmitter to each SCS 10. The multipath reflection is very much path dependent and therefore will vary from measurement to measurement and from path to path. It is not an object of this method to determine the multipath reflection for these calibration paths, but rather to determine the portion of the errors that are attributable

30



to the components of the SCS's 10. Typically, therefore, error values e1 and e3 will have a common component since they relate to the same first SCS 10A. Likewise, error values e2 and e4 will also have a common component since they relate to the second SCS 10B. It is known that while the multipath components can vary wildly, the component errors vary slowly and typically vary sinusoidally. Therefore, in the external calibration method, the error values  $\epsilon$  are filtered using a weighted, time-based filter that decreases the weight of the wildly varying multipath components while preserving the relatively slow changing error components attributed to the SCS's 10. One such exemplary filter used in the external calibration method is the Kalman filter.

10

The period between calibration transmissions is varied depending on the error drift rates determined for the SCS components. The period of the drift rate should be much longer than the period of the calibration interval. The Wireless Location System monitors the period of the drift rate to determine continuously the rate of change, and may periodically adjust the calibration interval, if needed. Typically, the calibration rate for a Wireless Location System such as one in accordance with the present invention is between 10 and 30 minutes. This corresponds well with the typical time period for the registration rate in a wireless communications system. If the Wireless Location System were to determine that the calibration interval must be adjusted to a rate faster than the registration rate of the wireless communications system, then the AP 14 (Figure 1) would automatically force the calibration transmitter to transmit by paging the transmitter at the prescribed interval. Each calibration transmitter is individually addressable and therefore the calibration interval associated with each calibration transmitter can be different.

15

Since the calibration transmitters used in the external calibration method are standard telephones, the Wireless Location System must have a mechanism to distinguish those telephones from the other wireless transmitters that are being located for various application purposes. The Wireless Location System maintains a list of the identities of the calibration transmitters, typically in the TLP 12 and in the AP 14. In a cellular system, the identity of the calibration transmitter can be the Mobile Identity Number, or MIN. When the calibration transmitter makes a transmission, the transmission is received by each SCS 10 and demodulated by the appropriate SCS 10. The Wireless Location System compares

20

25

30

the identity of the transmission with a pre-stored tasking list of identities of all calibration transmitters. If the Wireless Location System determines that the transmission was a calibration transmission, then the Wireless Location System initiates external calibration processing.

5

#### Internal Calibration Method

In addition to the external calibration method, it is an object of the present invention to calibrate all channels of the wideband digital receiver used in the SCS 10 of a Wireless Location System. The external calibration method will typically calibrate only a single  
10 channel of the multiple channels used by the wideband digital receiver. This is because the fixed calibration transmitters will typically scan to the highest-power control channel, which will typically be the same control channel each time. The transfer function of a wideband digital receiver, along with the other associated components, does not remain perfectly constant, however, and will vary with time and temperature. Therefore, even  
15 though the external calibration method can successfully calibrate a single channel, there is no assurance that the remaining channels will also be calibrated.

The internal calibration method, represented in the flowchart of Figure 2H, is particularly suited for calibrating an individual first receiver system (i.e., SCS 10) that is characterized  
20 by a time- and frequency-varying transfer function, wherein the transfer function defines how the amplitude and phase of a received signal will be altered by the receiver system and the receiver system is utilized in a location system to determine the location of a wireless transmitter by, in part, determining a difference in time of arrival of a signal transmitted by the wireless transmitter and received by the receiver system to be calibrated  
25 and another receiver system, and wherein the accuracy of the location estimate is dependent, in part, upon the accuracy of TDOA measurements made by the system. An example of a AMPS RCC transfer function is depicted in Figure 2I, which depicts how the phase of the transfer function varies across the 21 control channels spanning 630 KHz.

30 Referring to Figure 2H, the internal calibration method includes the steps of temporarily and electronically disconnecting the antenna used by a receiver system from the receiver system (step S-20); injecting an internally generated wideband signal with known and

stable signal characteristics into the first receiver system (step S-21); utilizing the generated wideband signal to obtain an estimate of the manner in which the transfer function varies across the bandwidth of the first receiver system (step S-22); and utilizing the estimate to mitigate the effects of the variation of the first transfer function on the time and frequency measurements made by the first receiver system (step S-23). One example of a stable wideband signal used for internal calibration is a comb signal, which is comprised of multiple individual, equal-amplitude frequency elements at a known spacing, such as 5 KHz. An example of such a signal is shown in Figure 2I.

10 The antenna must be temporarily disconnected during the internal calibration process to prevent external signals from entering the wideband receiver and to guarantee that the receiver is only receiving the stable wideband signal. The antenna is electronically disconnected only for a few milliseconds to minimize the chance of missing too much of a signal from a wireless transmitter. In addition, internal calibration is typically performed immediately after external calibration to minimize the possibility that the any component in the SCS 10 drifts during the interval between external and internal calibration. The antenna is disconnected from the wideband receiver using two electronically controlled RF relays (not shown). An RF relay cannot provide perfect isolation between input and output even when in the "off" position, but it can provide up to 70 dB of isolation. Two relays may be used in series to increase the amount of isolation and to further assure that no signal is leaked from the antenna to the wideband receiver during calibration. Similarly, when the internal calibration function is not being used, the internal calibration signal is turned off, and the two RF relays are also turned off to prevent leakage of the internal calibration signals into the wideband receiver when the receiver is collecting signals from wireless transmitters.

The external calibration method provides an absolute calibration of a single channel and the internal calibration method then calibrates each other channel relative to the channel that had been absolutely calibrated. The comb signal is particularly suited as a stable wideband signal because it can be easily generated using a stored replica of the signal and a digital to analog converter.

#### External Calibration Using Wideband Calibration Signal

The external calibration method described next may be used in connection with an SCS 10 receiver system characterized by a time- and frequency-varying transfer function, which preferably includes the antennas, filters, amplifiers, duplexors, multi-couplers, splitters, and cabling associated with the SCS receiver system. The method includes the step of 5 transmitting a stable, known wideband calibration signal from an external transmitter. The wideband calibration signal is then used to estimate the transfer function across a prescribed bandwidth of the SCS receiver system. The estimate of the transfer function is subsequently employed to mitigate the effects of variation of the transfer function on 10 subsequent TDOA/FDOA measurements. The external transmission is preferably of short duration and low power to avoid interference with the wireless communications system hosting the Wireless Location System.

In the preferred method, the SCS receiver system is synchronized with the external 15 transmitter. Such synchronization may be performed using GPS timing units. Moreover, the receiver system may be programmed to receive and process the entire wideband of the calibration signal only at the time that the calibration signal is being sent. The receiver system will not perform calibration processing at any time other than when in 20 synchronization with the external calibration transmissions. In addition, a wireless communications link is used between the receiver system and the external calibration transmitter to exchange commands and responses. The external transmitter may use a directional antenna to direct the wideband signal only at the antennas of the SCS receiver system. Such as directional antenna may be a Yagi antenna (i.e. linear end-fire array). The calibration method preferably includes making the external transmission only when the 25 directional antenna is aimed at the receiver system's antennas and the risk of multipath reflection is low.

#### Calibrating for Station Biases

Another aspect of the present invention concerns a calibration method to correct for station 30 biases in a SCS receiver system. The "station bias" is defined as the finite delay between when an RF signal from a wireless transmitter reaches the antenna and when that same signal reached the wideband receiver. The inventive method includes the step of

measuring the length of the cable from the antennas to the filters and determining the corresponding delays associated with the cable length. In addition, the method includes injecting a known signal into the filter, duplexor, multi-coupler, or RF splitter and measuring the delay and phase response versus frequency response from the input of each device to the wideband receiver. The delay and phase values are then combined and used to correct subsequent location measurements. When used with the GPS based timing generation described above, the method preferably includes correcting for the GPS cable lengths. Moreover, an externally generated reference signal is preferably used to monitor changes in station bias that may arise due to aging and weather. Finally, the station bias by RF channel and for each receiver system in the Wireless Location System is preferably stored in tabular form in the Wireless Location System for use in correcting subsequent location processing.

#### Performance Monitoring

The Wireless Location System uses methods similar to calibration for performance monitoring on a regular and ongoing basis. These methods are depicted in the flowcharts of Figure 2K and 2L. Two methods of performance monitoring are used: fixed phones and drive testing of surveyed points. The fixed phone method comprises the following steps (see Figure 2K):

- standard wireless transmitters are permanently placed at various points within the coverage area of the Wireless Location System (these are then known as the fixed phones) (step S-30);
- the points at which the fixed phones have been placed are surveyed so that their location is precisely known to within a predetermined distance, for example ten feet (step S-31);
- the surveyed locations are stored in a table in the AP 14 (step S-32);
- the fixed phones are permitted to register on the wireless communications system, at the rate and interval set by the wireless communications system for all wireless transmitters on the system (step S-33);
- at each registration transmission by a fixed phone, the Wireless Location System locates the fixed phone using normal location processing (as with the calibration

transmitters, the Wireless Location System can identify a transmission as being from a fixed phone by storing the identities in a table) (step S-34);  
the Wireless Location System computes an error between the calculated location determined by the location processing and the stored location determined by survey  
5 (step S-35);  
the location, the error value, and other measured parameters are stored along with a time stamp in a database in the AP 14 (step S-36);  
the AP 14 monitors the instant error and other measured parameters (collectively referred to as an extended location record) and additionally computes various  
10 statistical values of the error(s) and other measured parameters (step S-37); and  
if any of the error or other values exceed a pre-determined threshold or a historical statistical value, either instantaneously or after performing statistical filtering over a prescribed number of location estimates, the AP 14 signals an alarm to the operator of the Wireless Location System (step S-38).

15  
The extended location record includes a large number of measured parameters usefully for analyzing the instant and historical performance of the Wireless Location System. These parameters include: the RF channel used by the wireless transmitter, the antenna port(s) used by the Wireless Location System to demodulate the wireless transmission, the  
20 antenna ports from which the Wireless Location System requested RF data, the peak, average, and variance in power of the transmission over the interval used for location processing, the SCS 10 and antenna port chosen as the reference for location processing, the correlation value from the cross-spectra correlation between every other SCS 10 and antenna used in location processing and the reference SCS 10 and antenna, the delay value  
25 for each baseline, the multipath mitigation parameters, and the residual values remaining after the multipath mitigation calculations. Any of these measured parameters can be monitored by the Wireless Location System for the purpose of determining how the Wireless Location System is performing. One example of the type of monitoring performed by the Wireless Location System may be the variance between the instant value  
30 of the correlation on a baseline and the historical range of the correlation value. Another may be the variance between the instant value of the received power at a particular

antenna and the historical range of the received power. Many other statistical values can be calculated and this list is not exhaustive.

The number of fixed phones placed into the coverage area of the Wireless Location System can be determined based upon the density of the cell sites, the difficulty of the terrain, and the historical ease with which wireless communications systems have performed in the area. Typically the ratio is about one fixed phone for every six cell sites, however in some areas a ratio of one to one may be required. The fixed phones provide a continuous means to monitor the performance of the Wireless Location System, as well as the monitor any changes in the frequency plan that the carrier may have made. Many times, changes in the frequency plan will cause a variation in the performance of the Wireless Location System and the performance monitoring of the fixed phones provide an immediate indication to the Wireless Location System operator.

Drive testing of surveyed points is very similar to the fixed phone monitoring. Fixed phones typically can only be located indoors where access to power is available (i.e. the phones must be continuously powered on to be effective). To obtain a more complete measurement of the performance of the location performance, drive testing of outdoor test points is also performed. Referring to Figure 2L, as with the fixed phones, prescribed test points throughout the coverage area of the Wireless Location System are surveyed to within ten feet (step S-40). Each test point is assigned a code, where the code consists of either a "\*" or a "#", followed by a sequence number (step S-41). For example, "\*1001" through "\*1099" may be a sequence of 99 codes used for test points. These codes should be sequences, that when dialed, are meaningless to the wireless communications system (i.e. the codes do not cause a feature or other translation to occur in the MSC, except for an intercept message). The AP 14 stores the code for each test point along with the surveyed location (step S-42). Subsequent to these initial steps, any wireless transmitter dialing any of the codes will be triggered and located using normal location processing (steps S-43 and S-44). The Wireless Location System automatically computes an error between the calculated location determined by the location processing and the stored location determined by survey, and the location and the error value are stored along with a time stamp in a database in the AP 14 (steps S-45 and S-46). The AP 14 monitors the

instant error, as well as various historical statistical values of the error. If the error values exceed a pre-determined threshold or a historical statistical value, either instantaneously or after performing statistical filtering over a prescribed number of location estimates, the AP 14 signals an alarm to the operator of the Wireless Location System (step S-47).

5

#### TDOA Location Processor (TLP)

The TLP 12, depicted in Figures 1, 1A and 3, is a centralized digital signal processing system that manages many aspects of the Wireless Location System, especially the SCS's 10, and provides control over the location processing. Because location processing is DSP  
10 intensive, one of the major advantages of the TLP 12 is that the DSP resources can be shared among location processing initiated by transmissions at any of the SCS's 10 in a Wireless Location System. That is, the additional cost of DSP's at the SCS's 10 is reduced by having the resource centrally available. As shown in Figure 3, there are three major components of the TLP 12: DSP modules 12-1, T1/E1 communications modules 12-2 and  
15 a controller module 12-3.

The T1/E1 communications modules 12-2 provide the communications interface to the SCS's 10 (T1 and E1 are standard communications speeds available throughout the world). Each SCS 10 communicates to a TLP 12 using one or more DS0's (which are  
20 typically 56Kbps or 64 Kbps). Each SCS 10 typically connects to a fractional T1 or E1 circuit, using, e.g., a drop and insert unit or channel bank at the cell site. Frequently, this circuit is shared with the base station, which communicates with the MSC. At a central site, the DS0's assigned to the base station are separated from the DS0's assigned to the SCS's 10. This is typically accomplished external to the TLP 12 using a digital access and  
25 control system (DACS) 13A that not only separates the DS0's but also grooms the DS0's from multiple SCS's 10 onto full T1 or E1 circuits. These circuits then connect from the DACS 13A to the DACS 13B and then to the T1/E1 communications module on the TLP 12. Each T1/E1 communications module contains sufficient digital memory to buffer packets of data to and from each SCS 10 communicating with the module. A single TLP  
30 chassis may support one or more T1/E1 communications modules.



The DSP modules 12-1 provide a pooled resource for location processing. A single module may typically contain two to eight digital signal processors, each of which are equally available for location processing. Two types of location processing are supported: central based and station based, which are described in further detail below. The TLP controller 12-3 manages the DSP module(s) 12-1 to obtain optimal throughput. Each DSP module contains sufficient digital memory to store all of the data necessary for location processing. A DSP is not engaged until all of the data necessary to begin location processing has been moved from each of the involved SCS's 10 to the digital memory on the DSP module. Only then is a DSP given the specific task to locate a specific wireless transmitter. Using this technique, the DSP's, which are an expensive resource, are never kept waiting. A single TLP chassis may support one or more DSP modules.

The controller module 12-3 provides the real time management of all location processing within the Wireless Location System. The AP 14 is the top-level management entity within the Wireless Location System, however its database architecture is not sufficiently fast to conduct the real time decision making when transmissions occur. The controller module 12-3 receives messages from the SCS's 10, including: status, spectral energy in various channels for various antennas, demodulated messages, and diagnostics. This enables the controller to continuously determine events occurring in the Wireless Location System, as well as to send commands to take certain actions. When a controller module receives demodulated messages from SCS's 10, the controller module decides whether location processing is required for a particular wireless transmission. The controller module 12-3 also determines which SCS's 10 and antennas to use in location processing, including whether to use central based or station based location processing. The controller module commands SCS's 10 to return the necessary data, and commands the communications modules and DSP modules to sequentially perform their necessary roles in location processing. These steps are described below in further detail.

The controller module 12-3 maintains a table known as the Signal of Interest Table (SOIT). This table contains all of the criteria that may be used to trigger location processing on a particular wireless transmission. The criteria may include, for example, the Mobile Identity Number, the Mobile Station ID, the Electronic Serial Number, dialed

digits, System ID, RF channel number, cell site number or sector number, type of transmission, and other types of data elements. Some of the trigger events may have higher or lower priority levels associated with them for use in determining the order of processing. Higher priority location triggers will always be processing before lower priority location triggers. However, a lower priority trigger that has already begun location processing will complete the processing before being assigned to a higher priority task. The master Tasking List for the Wireless Location System is maintained on the AP 14, and copies of the Tasking List are automatically downloaded to the Signal of Interest Table in each TLP 12 in the Wireless Location System. The full Signal of Interest Table is downloaded to a TLP 12 when the TLP 12 is reset or first starts. Subsequent to those two events, only changes are downloaded from the AP 14 to each TLP 12 to conserve communications bandwidth. The TLP 12 to AP 14 communications protocol preferably contains sufficient redundancy and error checking to prevent incorrect data from ever being entered into the Signal of Interest Table. When the AP 14 and TLP 12 periodically have spare processing capacity available, the AP 14 reconfirms entries in the Signal of Interest Table to ensure that all Signal of Interest Table entries in the Wireless Location System are in full synchronization.

Each TLP chassis has a maximum capacity associated with the chassis. For example, a single TLP chassis may only have sufficient capacity to support between 48 and 60 SCS's 10. When a wireless communications system is larger than the capacity of a single TLP chassis, multiple TLP chassis are connected together using Ethernet networking. The controller module 12-3 is responsible for inter-TLP communications and networking, and communicates with the controller modules in other TLP chassis and with Application Processors 14 over the Ethernet network. Inter-TLP communications is required when location processing requires the use of SCS's 10 that are connected to different TLP chassis. Location processing for each wireless transmission is assigned to a single DSP module in a single TLP chassis. The controller modules 12-3 in TLP chassis select the DSP module on which to perform location processing, and then route all of the RF data used in location processing to that DSP module. If RF data is required from the SCS's 10 connected to more than one TLP 12, then the controller modules in all necessary TLP chassis communicate to move the RF data from all necessary SCS's 10 to their respective

connected TLP's 12 and then to the DSP module and TLP chassis assigned to the location processing. The controller module supports two fully independent Ethernet networks for redundancy. A break or failure in any one network causes the affected TLP's 12 to immediately shift all communications to the other network.

5

The controller modules 12-3 maintain a complete network map of the Wireless Location System, including the SCS's 10 associated with each TLP chassis. The network map is a table stored in the controller module containing a list of the candidate SCS/antennas that may be used in location processing, and various parameters associated with each of the SCS/antennas. The structure of an exemplary network map is depicted in Figure 3A. There is a separate entry in the table for each antenna connected to an SCS 10. When a wireless transmission occurs in an area that is covered by SCS's 10 communicating with more than one TLP chassis, the controller modules in the involved TLP chassis determine which TLP chassis will be the "master" TLP chassis for the purpose of managing location processing. Typically, the TLP chassis associated with the SCS 10 that has the primary channel assignment for the wireless transmission is assigned to be the master. However, another TLP chassis may be assigned instead if that TLP temporarily has no DSP resources available for location processing, or if most of the SCS's 10 involved in location processing are connected to another TLP chassis and the controller modules are minimizing inter-TLP communications. This decision making process is fully dynamic, but is assisted by tables in the TLP 12 that pre-determine the preferred TLP chassis for every primary channel assignment. The tables are created by the operator of the Wireless Location System, and programmed using the Network Operations Console.

25 The networking described herein functions for both TLP chassis associated with the same wireless carrier, as well as for chassis that overlap or border the coverage area between two wireless carriers. Thus it is possible for a TLP 12 belonging to a first wireless carrier to be networked and therefore receive RF data from a TLP 12 (and the SCS's 10 associated with that TLP 12) belonging to a second wireless carrier. This networking is particularly valuable in rural areas, where the performance of the Wireless Location System can be enhanced by deploying SCS's 10 at cell sites of multiple wireless carriers. Since in many cases wireless carriers do not collocate cell sites, this feature enables the

30

Wireless Location System to access more geographically diverse antennas than might be available if the Wireless Location System used only the cell sites from a single wireless carrier. As described below, the proper selection and use of antennas for location processing can enhance the performance of the Wireless Location System.

5

The controller module 12-3 passes many messages, including location records, to the AP 14, many of which are described below. Usually, however, demodulated data is not passed from the TLP 12 to the AP 14. If, however, the TLP 12 receives demodulated data from a particular wireless transmitter and the TLP 12 identifies the wireless transmitter as being a registered customer of a second wireless carrier in a different coverage area, the TLP 12 may pass the demodulated data to the first (serving) AP 14A. This will enable the first AP 14A to communicate with a second AP 14B associated with the second wireless carrier, and determine whether the particular wireless transmitter has registered for any type of location services. If so, the second AP 14B may instruct the first AP 14A to place the identity of the particular wireless transmitter into the Signal of Interest Table so that the particular wireless transmitter will be located for as long as the particular wireless transmitter is in the coverage area of the first Wireless Location System associated with the first AP 14A. When the first Wireless Location System has detected that the particular wireless transmitter has not registered in a time period exceeding a pre-determined threshold, the first AP 14A may instruct the second AP 14B that the identity of the particular wireless transmitter is being removed from the Signal of Interest Table for the reason of no longer being present in the coverage area associated with the first AP 14A.

#### Diagnostic Port

The TLP 12 supports a diagnostic port that is highly useful in the operation and diagnosis of problems within the Wireless Location System. This diagnostic port can be accessed either locally at a TLP 12 or remotely over the Ethernet network connecting the TLP's 12 to the AP's. The diagnostic port enables an operator to write to a file all of the demodulation and RF data received from the SCS's 10, as well as the intermediate and final results of all location processing. This data is erased from the TLP 12 after processing a location estimate, and therefore the diagnostic port provides the means to save the data for later post-processing and analysis. The inventor's experience in operating

large scale wireless location systems is that a very small number of location estimates can occasionally have very large errors, and these large errors can dominate the overall operating statistics of the Wireless Location System over any measurement period. Therefore, it is important to provide the operator with a set of tools that enable the  
5 Wireless Location System to detect and trap the cause of the very large errors to diagnose and mitigate those errors. The diagnostic port can be set to save the above information for all location estimates, for location estimates from particular wireless transmitters or at particular test points, or for location estimates that meet a certain criteria. For example, for fixed phones or drive testing of surveyed points, the diagnostic port can determine the  
10 error in the location estimate in real time and then write the above described information only for those location estimates whose error exceeds a predetermined threshold. The diagnostic port determines the error in real time by storing the surveyed latitude, longitude coordinate of each fixed phone and drive test point in a table, and then calculating a radial error when a location estimate for the corresponding test point is made.

15

#### Redundancy

The TLP's 12 implement redundancy using several inventive techniques, allowing the Wireless Location System to support an M plus N redundancy method. M plus N  
20 redundancy means that N redundant (or standby) TLP chassis are used to provide full redundant backup to M online TLP chassis. For example, M may be ten and N may be two.

First, the controller modules in different TLP chassis continuously exchange status and "heartbeat" messages at pre-determined time intervals between themselves and with every  
25 AP 14 assigned to monitor the TLP chassis. Thus, every controller module has continuous and full status of every other controller module in the Wireless Location System. The controller modules in different TLP chassis periodically select one controller module in one TLP 12 to be the master controller for a group of TLP chassis. The master controller may decide to place a first TLP chassis into off-line status if the first TLP 12A reports a  
30 failed or degraded condition in its status message, or if the first TLP 12A fails to report any status or heartbeat messages within its assigned and pre-determined time. If the master controller places a first TLP 12A into off-line status, the master controller may assign a

second TLP 12B to perform a redundant switchover and assume the tasks of the off-line first TLP 12A. The second TLP 12B is automatically sent the configuration that had been loaded into the first TLP 12A; this configuration may be downloaded from either the master controller or from an AP 14 connected to the TLP's 12. The master controller may  
5 be a controller module on any one of the TLP's 12 that is not in off-line status, however there is a preference that the master controller be a controller module in a stand-by TLP 12. When the master controller is the controller module in a stand-by TLP 12, the time required to detect a failed first TLP 12A, place the first TLP 12A into off-line status, and then perform a redundant switchover can be accelerated.

10

Second, all of the T1 or E1 communications between the SCS's 10 and each of the TLP T1/E1 communications modules 12-2 are preferably routed through a high-reliability DACS that is dedicated to redundancy control. The DACS 13B is connected to every groomed T1/E1 circuit containing DS0's from SCS's 10 and is also connected to every  
15 T1/E1 communications module 12-2 of every TLP 12. Every controller module at every TLP 12 contains a map of the DACS 13B that describes the DACS' connection list and port assignments. This DACS 13B is connected to the Ethernet network described above and can be controlled by any of the controller modules 12-3 at any of the TLP's 12. When a second TLP 12 is placed into off-line status by a master controller, the master controller  
20 sends commands to the DACS 13B to switch the groomed T1/E1 circuit communicating with the first TLP 12A to a second TLP 12B which had been in standby status. At the same time, the AP 14 downloads the complete configuration file that was being used by the second (and now off-line) TLP 12B to the third (and now online) TLP 12C. The time from the first detection of a failed first TLP chassis to the complete switch-over and  
25 assumption of processing responsibilities by a third TLP chassis is typically less than few seconds. In many cases, no RF data is lost by the SCS's 10 associated with the failed first TLP chassis, and location processing can continue without interruption. At the time of a TLP fail-over when a first TLP 12A is placed into off-line status, the NOC 16 creates an alert to notify the Wireless Location System operator that the event has occurred.

30

Third, each TLP chassis contains redundant power supplies, fans, and other components. A TLP chassis can also support multiple DSP modules, so that the failure of a single DSP

module or even a single DSP on a DSP module reduces the overall amount of processing resources available but does not cause the failure of the TLP chassis. In all of the cases described in this paragraph, the failed component of the TLP 12 can be replaced without placing the entire TLP chassis into off-line status. For example, if a single power supply fails, the redundant power supply has sufficient capacity to singly support the load of the chassis. The failed power supply contains the necessary circuitry to remove itself from the load of the chassis and not cause further degradation in the chassis. Similarly, a failed DSP module can also remove itself from the active portions of the chassis, so as to not cause a failure of the backplane or other modules. This enables the remainder of the chassis, including the second DSP module, to continue to function normally. Of course, the total processing throughput of the chassis is reduced but a total failure is avoided.

#### Application Processor (AP) 14

The AP 14 is a centralized database system, comprising a number of software processes that manage the entire Wireless Location System, provide interfaces to external users and applications, store location records and configurations, and support various application-related functionality. The AP 14 uses a commercial hardware platform that is sized to match the throughput of the Wireless Location System. The AP 14 also uses a commercial relational database system (RDBMS), which has been significantly customized to provide the functionality described herein. While the SCS 10 and TLP 12 preferably operate together on a purely real time basis to determine location and create location records, the AP 14 can operate on both a real time basis to store and forward location records and a non-real time basis to post-process location records and provide access and reporting over time. The ability to store, retrieve, and post-process location records for various types of system and application analysis has proven to be a powerful advantage of the present invention. The main collection of software processes is known as the ApCore, which is shown in Figure 4 and includes the following functions:

The AP Performance Guardian (ApPerfGuard) is a dedicated software process that is responsible for starting, stopping, and monitoring most other ApCore processes as well as ApCore communications with the NOC 16. Upon receiving a configuration update command from the NOC, ApPerfGuard updates the database and notifies all other

- processes of the change. ApPerfGuard starts and stops appropriate processes when the NOC directs the ApCore to enter specific run states, and constantly monitors other software processes scheduled to be running to restart them if they have exited or stopping and restarting any process that is no longer properly responding. ApPerfGuard is assigned to one of the highest processing priorities so that this process cannot be blocked by another process that has "run away". ApPerfGuard is also assigned dedicated memory that is not accessible by other software processes to prevent any possible corruption from other software processes.
- 10 The AP Dispatcher (ApMnDsptch) is a software process that receives location records from the TLP's 12 and forwards the location records to other processes. This process contains a separate thread for each physical TLP 12 configured in the system, and each thread receives location records from that TLP 12. For system reliability, the ApCore maintains a list containing the last location record sequence number received from each TLP 12, and sends this sequence number to the TLP 12 upon initial connection. Thereafter, the AP 14 and the TLP 12 maintain a protocol whereby the TLP 12 sends each location record with a unique identifier. ApMnDsptch forwards location records to multiple processes, including Ap911, ApDbSend, ApDbRecvLoc, and ApDbFileRecv.
- 20 The AP Tasking Process (ApDbSend) controls the Tasking List within the Wireless Location System. The Tasking List is the master list of all of the trigger criteria that determines which wireless transmitters will be located, which applications created the criteria, and which applications can receive location record information. The ApDbSend process contains a separate thread for each TLP 12, over which the ApDbSend synchronizes the Tasking List with the Signal of Interest Table on each TLP 12. ApDbSend does not send application information to the Signal of Interest Table, only the trigger criteria. Thus the TLP 12 does not know why a wireless transmitter must be located. The Tasking List allows wireless transmitters to be located based upon Mobile Identity Number (MIN), Mobile Station Identifier (MSID), Electronic Serial Number (ESN) and other identity numbers, dialed sequences of characters and / or digits, home System ID (SID), originating cell site and sector, originating RF channel, or message type. The Tasking List allows multiple applications to receive location records from the same



wireless transmitter. Thus, a single location record from a wireless transmitter that has dialed "911" can be sent, for example, to a 911 PSAP, a fleet management application, a traffic management application, and to an RF optimization application.

- 5 The Tasking List also contains a variety of flags and field for each trigger criteria, some of which are described elsewhere in this specification. One flag, for example, specifies the maximum time limit before which the Wireless Location System must provide a rough or final estimate of the wireless transmitter. Another flag allows location processing to be disabled for a particular trigger criteria such as the identity of the wireless transmitter.
- 10 Another field contains the authentication required to make changes to the criteria for a particular trigger; authentication enables the operator of the Wireless Location System to specify which applications are authorized to add, delete, or make changes to any trigger criteria and associated fields or flags. Another field contains the Location Grade of Service associated with the trigger criteria; Grade of Service indicates to the Wireless Location
- 15 System the accuracy level and priority level desired for the location processing associated with a particular trigger criteria. For example, some applications may be satisfied with a rough location estimate (perhaps for a reduced location processing fee), while other applications may be satisfied with low priority processing that is not guaranteed to complete for any given transmission (and which may be pre-empted for high priority
- 20 processing tasks). The Wireless Location System also includes means to support the use of wildcards for trigger criteria in the Tasking List. For example, a trigger criteria can be entered as "MIN = 215555\*\*\*\*". This will cause the Wireless Location System to trigger location processing for any wireless transmitter whose MIN begins with the six digits 215555 and ends with any following four digits. The wildcard characters can be placed
- 25 into any position in a trigger criteria. This feature can save on the number of memory locations required in the Tasking List and Signal of Interest Table by grouping blocks of related wireless transmitters together.

- ApDbSend also supports dynamic tasking. For example, the MIN, ESN, MSID, or other
- 30 identity of any wireless transmitter that has dialed "911" will automatically be placed onto the Tasking List by ApDbSend for one hour. Thus, any further transmissions by the wireless transmitter that dialed "911" will also be located in case of further emergency.

For example, if a PSAP calls back a wireless transmitter that had dialed "911" within the last hour, the Wireless Location System will trigger on the page response message from the wireless transmitter, and can make this new location record available to the PSAP. This dynamic tasking can be set for any interval of time after an initiation event, and for any type of trigger criteria. The ApDbSend process is also a server for receiving tasking requests from other applications. These applications, such as fleet management, can send tasking requests via a socket connection, for example. These applications can either place or remove trigger criteria. ApDbSend conducts an authentication process with each application to verify that that the application has been authorized to place or remove trigger criteria, and each application can only change trigger criteria related to that application.

The AP 911 Process (Ap911) manages each interface between the Wireless Location System and E9-1-1 network elements, such as tandem switches, selective routers, ALI databases and/or PSAPs. The Ap911 process contains a separate thread for each connection to a E9-1-1 network element, and can support more than one thread to each network element. The Ap911 process can simultaneously operate in many modes based upon user configuration, and as described herein. The timely processing of E9-1-1 location records is one of the highest processing priorities in the AP 14, and therefore the Ap911 executes entirely out of random access memory (RAM) to avoid the delay associated with first storing and then retrieving a location record from any type of disk. When ApMnDsptch forwards a location record to Ap911, Ap911 immediately makes a routing determination and forwards the location record over the appropriate interface to a E9-1-1 network element. A separate process, operating in parallel, records the location record into the AP 14 database.

The AP 14, through the Ap911 process and other processes, supports two modes of providing location records to applications, including E9-1-1: "push" and "pull" modes. Applications requesting push mode receive a location record as soon as it is available from the AP 14. This mode is especially effective for E9-1-1 which has a very time critical need for location records, since E9-1-1 networks must route wireless 9-1-1 calls to the correct PSAP within a few seconds after a wireless caller has dialed "911". Applications

- requesting pull mode do not automatically receive location records, but rather must send a query to the AP 14 regarding a particular wireless transmitter in order to receive the last, or any other location record, about the wireless transmitter. The query from the application can specify the last location record, a series of location records, or all location records
- 5 meeting a specific time or other criteria, such as type of transmission. An example of the use of pull mode in the case of a "911" call is the E9-1-1 network first receiving the voice portion of the "911" call and then querying the AP 14 to receive the location record associated with that call.
- 10 When the Ap911 process is connected to many E9-1-1 networks elements, Ap911 must determine to which E9-1-1 network element to push the location record (assuming that "push" mode has been selected). The AP 14 makes this determination using a dynamic routing table. The dynamic routing table is used to divide a geographic region into cells. Each cell, or entry, in the dynamic routing table contains the routing instructions for that
- 15 cell. It is well known that one minute of latitude is 6083 feet, which is about 365 feet per millidegree. Additionally, one minute of longitude is  $\cos(\text{latitude}) \times 6083$  feet, which for the Philadelphia area is about 4659 feet, or about 280 feet per millidegree. A table of size one thousand by one thousand, or one million cells, can contain the routing instructions for an area that is about 69 miles by 53 miles, which is larger than the area of
- 20 Philadelphia in this example, and each cell could contain a geographic area of 365 feet by 280 feet. The number of bits allocated to each entry in the table must only be enough to support the maximum number of routing possibilities. For example, if the total number of routing possibilities is sixteen or less, then the memory for the dynamic routing table is one million times four bits, or one-half megabyte. Using this scheme, an area the size of
- 25 Pennsylvania could be contained in a table of approximately twenty megabytes or less, with ample routing possibilities available. Given the relatively inexpensive cost of memory, this inventive dynamic routing table provides the AP 14 with a means to quickly push the location records for "911" calls only to the appropriate E9-1-1 network element.
- 30 The AP 14 allows each entry in dynamic routing to be populated using manual or automated means. Using the automated means, for example, an electronic map application can create a polygon definition of the coverage area of a specific E9-1-1 network element,

such as a PSAP. The polygon definition is then translated into a list of latitude, longitude points contained within the polygon. The dynamic routing table cell corresponding to each latitude, longitude point is then given the routing instruction for that E9-1-1 network element that is responsible for that geographic polygon.

5

When the Ap911 process receives a "911" location record for a specific wireless transmitter, Ap911 converts the latitude, longitude into the address of a specific cell in the dynamic routing table. Ap911 then queries the cell to determine the routing instructions, which may be push or pull mode and the identity of the E9-1-1 network element  
10 responsible for serving the geographic area in which the "911" call occurred. If push mode has been selected, then Ap911 automatically pushes the location record to that E9-1-1 network element. If pull mode has been selected, then Ap911 places the location record into a circular table of "911" location records and awaits a query.

15 The dynamic routing means described above entails the use of a geographically defined database that may be applied to other applications in addition to 911, and is therefore supported by other processes in addition to Ap911. For example, the AP 14 can automatically determine the billing zone from which a wireless call was placed for a Location Sensitive Billing application. In addition, the AP 14 may automatically send an  
20 alert when a particular wireless transmitter has entered or exited a prescribed geographic area defined by an application. The use of particular geographic databases, dynamic routing actions, any other location triggered actions are defined in the fields and flags associated with each trigger criteria. The Wireless Location System includes means to easily manage these geographically defined databases using an electronic map that can  
25 create polygons encompassing a prescribed geographic area. The Wireless Location System extracts from the electronic map a table of latitude, longitude points contained with the polygon. Each application can use its own set of polygons, and can define a set of actions to be taken when a location record for a triggered wireless transmission is contained within each polygon in the set.

30

The AP Database Receive Process (ApDbRecvLoc) receives all location records from ApMnDsptch via shared memory, and places the location records into the AP location

database. ApDbRecvLoc starts ten threads that each retrieve location records from shared memory, validate each record before inserting the records into the database, and then inserts the records into the correct location record partition in the database. To preserve integrity, location records with any type of error are not written into the location record database but are instead placed into an error file that can be reviewed by the Wireless  
5 Location System operator and then manually entered into the database after error resolution. If the location database has failed or has been placed into off-line status, location records are written to a flat file where they can be later processed by ApDbFileRecv.

10 The AP File Receive Process (ApDbFileRecv) reads flat files containing location records and inserts the records into the location database. Flat files are a safe mechanism used by the AP 14 to completely preserve the integrity of the AP 14 in all cases except a complete failure of the hard disk drives. There are several different types of flat files read by  
15 ApDbFileRecv, including Database Down, Synchronization, Overflow, and Fixed Error. Database Down flat files are written by the ApDbRecvLoc process if the location database is temporarily inaccessible; this file allows the AP 14 to ensure that location records are preserved during the occurrence of this type of problem. Synchronization flat files are written by the ApLocSync process (described below) when transferring location records  
20 between pairs of redundant AP systems. Overflow flat files are written by ApMnDsptch when location records are arriving into the AP 14 at a rate faster than ApDbRecvLoc can process and insert the records into the location database. This may occur during very high peak rate periods. The overflow files prevent any records from being lost during peak periods. The Fixed Error flat files contain location records that had errors but have now  
25 been fixed, and can now be inserted into the location database.

Because the AP 14 has a critical centralized role in the Wireless Location System, the AP 14 architecture has been designed to be fully redundant. A redundant AP 14 system includes fully redundant hardware platforms, fully redundant RDBMS, redundant disk  
30 drives, and redundant networks to each other, the TLP's 12, the NOC's 16, and external applications. The software architecture of the AP 14 has also been designed to support fault tolerant redundancy. The following examples illustrate functionality supported by the

redundant AP's. Each TLP 12 sends location records to both the primary and the redundant AP 14 when both AP's are in an online state. Only the primary AP 14 will process incoming tasking requests, and only the primary AP 14 will accept configuration change requests from the NOC 16. The primary AP 14 then synchronizes the redundant AP 14 under careful control. Both the primary and redundant AP's will accept basic startup and shutdown commands from the NOC. Both AP's constantly monitor their own system parameters and application health and monitor the corresponding parameters for the other AP 14, and then decide which AP 14 will be primary and which will be redundant based upon a composite score. This composite score is determined by compiling errors reported by various processes to a shared memory area, and monitoring swap space and disk space. There are several processes dedicated to supporting redundancy.

The AP Location Synchronization Process (ApLocSync) runs on each AP 14 and detects the need to synchronize location records between AP's, and then creates "sync records" that list the location records that need to be transferred from one AP 14 to another AP 14. The location records are then transferred between AP's using a socket connection. ApLocSync compares the location record partitions and the location record sequence numbers stored in each location database. Normally, if both the primary and redundant AP 14 are operating properly, synchronization is not needed because both AP's are receiving location records simultaneously from the TLP's 12. However, if one AP 14 fails or is placed in an off-line mode, then synchronization will later be required. ApLocSync is notified whenever ApMnDsptch connects to a TLP 12 so it can determine whether synchronization is required.

The AP Tasking Synchronization Process (ApTaskSync) runs on each AP 14 and synchronizes the tasking information between the primary AP 14 and the redundant AP 14. ApTaskSync on the primary AP 14 receives tasking information from ApDbSend, and then sends the tasking information to the ApTaskSync process on the redundant AP 14. If the primary AP 14 were to fail before ApTaskSync had completed replicating tasks, then ApTaskSync will perform a complete tasking database synchronization when the failed AP 14 is placed back into an online state.

The AP Configuration Synchronization Process (ApConfigSync) runs on each AP 14 and synchronizes the configuration information between the primary AP 14 and the redundant AP 14. ApConfigSync uses a RDBMS replication facility. The configuration information includes all information needed by the SCS's 10, TLP's 12, and AP's 14 for proper  
5 operation of the Wireless Location System in a wireless carrier's network.

In addition to the core functions described above, the AP 14 also supports a large number of processes, functions, and interfaces useful in the operation of the Wireless Location System, as well as useful for various applications that desire location information. While  
10 the processes, functions, and interfaces described herein are in this section pertaining to the AP 14, the implementation of many of these processes, functions, and interfaces permeates the entire Wireless Location System and therefore their inventive value should be not read as being limited only to the AP 14.

#### 15 Roaming

The AP 14 supports "roaming" between wireless location systems located in different cities or operated by different wireless carriers. If a first wireless transmitter has subscribed to an application on a first Wireless Location System, and therefore has an entry in the Tasking List in the first AP 14 in the first Wireless Location System, then the  
20 first wireless transmitter may also subscribe to roaming. Each AP 14 and TLP 12 in each Wireless Location System contains a table in which a list of valid "home" subscriber identities is maintained. The list is typically a range, and for example, for current cellular telephones, the range can be determined by the NPA/NXX codes (or area code and exchange) associated with the MIN or MSID of cellular telephones. When a wireless  
25 transmitter meeting the "home" criteria makes a transmission, a TLP 12 receives demodulated data from one or more SCS's 10 and checks the trigger information in the Signal of Interest Table . If any trigger criterion is met, the location processing begins on that transmission; otherwise, the transmission is not processed by the Wireless Location System.

30 When a first wireless transmitter not meeting the "home" criterion makes a transmission in a second Wireless Location System, the second TLP 12 in the second Wireless Location

System checks the Signal of Interest Table for a trigger. One of three actions then occurs:

- (i) if the transmission meets an already existing criteria in the Signal of Interest Table, the transmitter is located and the location record is forwarded from the second AP 14 in the second Wireless Location System to the first AP 14 in the first Wireless Location System;
- 5 (ii) if the first wireless transmitter has a "roamer" entry in the Signal of Interest Table indicating that the first wireless transmitter has "registered" in the second Wireless Location System but has no trigger criteria, then the transmission is not processed by the second Wireless Location System and the expiration timestamp is adjusted as described below;
- 10 (iii) if the first wireless transmitter has no "roamer" entry and therefore has not "registered", then the demodulated data is passed from the TLP 12 to the second AP 14.

In the third case above, the second AP 14 uses the identity of the first wireless transmitter to identify the first AP 14 in the first Wireless Location System as the "home" Wireless Location System of the first wireless transmitter. The second AP 14 in the second Wireless Location System sends a query to the first AP 14 in the first Wireless Location System to determine whether the first wireless transmitter has subscribed to any location application and therefore has any trigger criteria in the Tasking List of the first AP 14. If a trigger is present in the first AP 14, the trigger criteria, along with any associated fields and flags, is sent from the first AP 14 to the second AP 14 and entered in the Tasking List and the Signal of Interest Table as a "roamer" entry with trigger criteria. If the first AP 14 responds to the second AP 14 indicating that the first wireless transmitter has no trigger criteria, then the second AP 14 "registers" the first wireless transmitter in the Tasking List and the Signal of Interest Table as a "roamer" with no trigger criteria. Thus both current and future transmissions from the first wireless transmitter can be positively identified by the TLP 12 in the second Wireless Location System as being registered without trigger criteria, and the second AP 14 is not required to make additional queries to the first AP 14.

When the second AP 14 registers the first wireless transmitter with a roamer entry in the Tasking List and the Signal of Interest Table with or without trigger criteria, the roamer entry is assigned an expiration timestamp. The expiration timestamp is set to the current time plus a predetermined first interval. Every time the first wireless transmitter makes a transmission, the expiration timestamp of the roamer entry in the Tasking List and the



Signal of Interest Table is adjusted to the current time of the most recent transmission plus the predetermined first interval. If the first wireless transmitter makes no further transmissions prior to the expiration timestamp of its roamer entry, then the roamer entry is automatically deleted. If, subsequent to the deletion, the first wireless transmitter makes another transmission, then the process of registering occurs again.

The first AP 14 and second AP 14 maintain communications over a wide area network. The network may be based upon TCP/IP or upon a protocol similar to the most recent version of IS-41. Each AP 14 in communications with other AP's in other wireless location systems maintains a table that provides the identity of each AP 14 and Wireless Location System corresponding to each valid range of identities of wireless transmitters.

#### Multiple Pass Location Records

Certain applications may require a very fast estimate of the general location of a wireless transmitter, followed by a more accurate estimate of the location that can be sent subsequently. This can be valuable, for example, for E9-1-1 systems that handle wireless calls and must make a call routing decision very quickly, but can wait a little longer for a more exact location to be displayed upon the E9-1-1 call-taker's electronic map terminal. The Wireless Location System supports these applications with an inventive multiple pass location processing mode, described later. The AP 14 supports this mode with multiple pass location records. For certain entries, the Tasking List in the AP 14 contains a flag indicating the maximum time limit before which a particular application must receive a rough estimate of location, and a second maximum time limit in which a particular application must receive a final location estimate. For these certain applications, the AP 14 includes a flag in the location record indicating the status of the location estimate contained in the record, which may, for example, be set to first pass estimate (i.e. rough) or final pass estimate. The Wireless Location System will generally determine the best location estimate within the time limit set by the application, that is the Wireless Location System will process the most amount of RF data that can be supported in the time limit. Given that any particular wireless transmission can trigger a location record for one or more applications, the Wireless Location System supports multiple modes simultaneously. For example, a wireless transmitter with a particular MIN can dial "911". This may trigger

a two-pass location record for the E9-1-1 application, but a single pass location record for a fleet management application that is monitoring that particular MIN. This can be extended to any number of applications.

5 Multiple Demodulation and Triggers

In wireless communications systems in urban or dense suburban areas, frequencies or channels can be re-used several times within relatively close distances. Since the Wireless Location System is capable of independently detecting and demodulating wireless transmissions without the aid of the wireless communications system, a single wireless transmission can frequently be detected and successfully demodulated at multiple SCS's  
10 within the Wireless Location System. This can happen both intentionally and unintentionally. An unintentional occurrence is caused by a close frequency re-use, such that a particular wireless transmission can be received above a predetermined threshold at more than one SCS 10, when each SCS 10 believes it is monitoring only transmissions  
15 that occur only within the cell site collocated with the SCS 10. An intentional occurrence is caused by programming more than one SCS 10 to detect and demodulate transmissions that occur at a particular cell site and on a particular frequency. As described earlier, this is generally used with adjacent or nearby SCS's 10 to provide system demodulation redundancy to further increase the probability that any particular wireless transmission is  
20 successful detected and demodulated.

Either type of event could potentially lead to multiple triggers within the Wireless Location System, causing location processing to be initiated several times for the same transmission. This causes an excess and inefficient use of processing and communications  
25 resources. Therefore, the Wireless Location System includes means to detect when the same transmission has been detected and demodulated more than once, and to select the best demodulating SCS 10 as the starting point for location processing. When the Wireless Location System detects and successfully demodulates the same transmission multiple times at multiple SCS/antennas, the Wireless Location System uses the following criteria  
30 to select the one demodulating SCS/antenna to use to continue the process of determining whether to trigger and possibly initiate location processing (again, these criteria may be weighted in determining the final decision): (i) an SCS/antenna collocated at the cell site

to which a particular frequency has been assigned is preferred over another SCS/antenna, but this preference may be adjusted if there is no operating and on-line SCS/antenna collocated at the cell site to which the particular frequency has been assigned, (ii) SCS/antennas with higher average SNR are preferred over those with lower average SNR, and (iii) SCS/antennas with fewer bit errors in demodulating the transmission are preferred over those with higher bit errors. The weighting applied to each of these preferences may be adjusted by the operator of the Wireless Location System to suit the particular design of each system.

10 Interface to Wireless Communications System

The Wireless Location System contains means to communicate over an interface to a wireless communications system, such as a mobile switching center (MSC) or mobile positioning controller (MPC). This interface may be based, for example, on a standard secure protocol such as the most recent version of the IS-41 or TCP/IP protocols. The formats, fields, and authentication aspects of these protocols are well known. The Wireless Location System supports a variety of command / response and informational messages over this interface that are designed to aid in the successful detection, demodulation, and triggering of wireless transmissions, as well as providing means to pass location records to the wireless communications system. In particular, this interface provides means for the Wireless Location System to obtain information about which wireless transmitters have been assigned to particular voice channel parameters at particular cell sites. Example messages supported by the Wireless Location System over this interface to the wireless communications system include the following:

25 Query on MIN / MDN / MSID / IMSI / TMSI Mapping – Certain types of wireless transmitters will transmit their identity in a familiar form that can be dialed over the telephone network. Other types of wireless transmitters transmit an identity that cannot be dialed, but which is translated into a number that can be dialed using a table inside of the wireless communications system. The transmitted identity is permanent in most cases, but can also be temporary. Users of location applications connected to the AP 30 14 typically prefer to place triggers onto the Tasking List using identities that can be dialed. Identities that can be dialed are typically known as Mobile Directory Numbers

(MDN). The other types of identities for which translation may be required includes Mobile Identity Number (MIN), Mobile Subscriber Identity (MSID), International Mobile Subscriber Identity (IMSI), and Temporary Mobile Subscriber Identity (TMSI). If the wireless communications system has enabled the use of encryption for any of the data fields in the messages transmitted by wireless transmitters, the Wireless Location System may also query for encryption information along with the identity information. The Wireless Location System includes means to query the wireless communications system for the alternate identities for a trigger identity that has been placed onto the Tasking List by a location application, or to query the wireless communications system for alternate identities for an identity that has been demodulated by an SCS 10. Other events can also trigger this type of query. For this type of query, typically the Wireless Location System initiates the command, and the wireless communications system responds.

Query / Command Change on Voice RF Channel Assignment – Many wireless transmissions on voice channels do not contain identity information. Therefore, when the Wireless Location System is triggered to perform location processing on a voice channel transmission, the Wireless Location System queries the wireless communication system to obtain the current voice channel assignment information for the particular transmitter for which the Wireless Location System has been triggered. For an AMPS transmission, for example, the Wireless Location System preferably requires the cell site, sector, and RF channel number currently in use by the wireless transmitter. For a TDMA transmission, for example, the Wireless Location System preferably requires the cell site, sector, RF channel number, and timeslot currently in use by the wireless transmitter. Other information elements that may be needed includes long code mask and encryption keys. In general, the Wireless Location System will initiate the command, and the wireless communications system will respond. However, the Wireless Location System will also accept a trigger command from the wireless communications system that contains the information detailed herein.

5 The timing on this command / response message set is very critical since voice channel handoffs can occur quite frequently in wireless communications systems. That is, the Wireless Location System will locate any wireless transmitter that is transmitting on a particular channel – therefore the Wireless Location System and the wireless  
10 communications system must jointly be certain that the identity of the wireless transmitter and the voice channel assignment information are in perfect synchronization. The Wireless Location System uses several means to achieve this objective. The Wireless Location System may, for example, query the voice channel assignment information for a particular wireless transmitter, receive the necessary RF data, then again query the voice channel assignment information for that same wireless  
15 transmitter, and then verify that the status of the wireless transmitter did not change during the time in which the RF data was being collected by the Wireless Location System. Location processing is not required to complete before the second query, since it is only important to verify that the correct RF data was received. The Wireless  
20 Location System may also, for example, as part of the first query command the wireless communications system to prevent a handoff from occurring for the particular wireless transmitter during the time period in which the Wireless Location System is receiving the RF data. Then, subsequent to collecting the RF data, the Wireless Location System will again query the voice channel assignment information for that  
25 same wireless transmitter, command the wireless communications system to again permit handoffs for said wireless transmitter and then verify that the status of the wireless transmitter did not change during the time in which the RF data was being collected by the Wireless Location System.

30 For various reasons, either the Wireless Location System or the wireless communications system may prefer that the wireless transmitter be assigned to another voice RF channel prior to performing location processing. Therefore, as part of the command / response sequence, the wireless communications system may instruct the Wireless Location System to temporarily suspend location processing until the  
35 wireless communications system has completed a handoff sequence with the wireless transmitter, and the wireless communications system has notified the Wireless Location System that RF data can be received, and the voice RF channel upon which

the data can be received. Alternately, the Wireless Location System may determine that the particular voice RF channel which a particular wireless transmitter is currently using is unsuitable for obtaining an acceptable location estimate, and request that the wireless communications system command the wireless transmitter to handoff.

5 Alternately, the Wireless Location System may request that the wireless communications system command the wireless transmitter to handoff to a series of voice RF channels in sequence in order to perform a series of location estimates, whereby the Wireless Location System can improve upon the accuracy of the location estimate through the series of handoffs; this method is further described later.

10

The Wireless Location System can also use this command / response message set to query the wireless communications system about the identity of a wireless transmitter that had been using a particular voice channel (and timeslot, etc.) at a particular cell site at a particular time. This enables the Wireless Location System to first perform location processing on transmissions without knowing the identities, and then to later determine the identity of the wireless transmitters making the transmissions and append this information to the location record. This particular inventive feature enables the use of automatic sequential location of voice channel transmissions.

15

20 Receive Triggers – The Wireless Location System can receive triggers from the wireless communications system to perform location processing on a voice channel transmission without knowing the identity of the wireless transmitter. This message set bypasses the Tasking List, and does not use the triggering mechanisms within the Wireless Location System. Rather, the wireless communications system alone determines which wireless transmissions to locate, and then send a command to the Wireless Location System to collect RF data from a particular voice channel at a particular cell site and to perform location processing. The Wireless Location System responds with a confirmation containing a timestamp when the RF data was collected. The Wireless Location System also responds with an appropriate format location record when location processing has completed. Based upon the time of the command to Wireless Location System and the response with the RF data collection timestamp, the wireless communications system determines whether the wireless transmitter status

25

30

changed subsequent to the command and whether there is a good probability of successful RF data collection.

5           Make Transmit – The Wireless Location System can command the wireless communications system to force a particular wireless transmitter to make a transmission at a particular time, or within a prescribed range of times. The wireless communications system responds with a confirmation and a time or time range in which to expect the transmission. The types of transmissions that the Wireless Location System can force include, for example, audit responses and page responses. 10           Using this message set, the Wireless Location System can also command the wireless communications system to force the wireless transmitter to transmit using a higher power level setting. In many cases, wireless transmitters will attempt to use the lowest power level settings when transmitting in order to conserve battery life. In order to improve the accuracy of the location estimate, the Wireless Location System may prefer that the wireless transmitter use a higher power level setting. The wireless 15           communications system will respond to the Wireless Location System with a confirmation that the higher power level setting will be used and a time or time range in which to expect the transmission.

20           Delay Wireless Communications System Response to Mobile Access – Some air interface protocols, such as CDMA, use a mechanism in which the wireless transmitter initiates transmissions on a channel, such as an Access Channel, for example, at the lowest or a very low power level setting, and then enters a sequence of steps in which (i) the wireless transmitter makes an access transmission; (ii) the wireless transmitter 25           waits for a response from the wireless communications system; (iii) if no response is received by the wireless transmitter from the wireless communications system within a predetermined time, the wireless transmitter increases its power level setting by a predetermined amount, and then returns to step (i); (iv) if a response is received by the wireless transmitter from the wireless communications system within a predetermined 30           time, the wireless transmitter then enters a normal message exchange. This mechanism is useful to ensure that the wireless transmitter uses only the lowest useful power level setting for transmitting and does not further waste energy or battery life. It is possible,

however, that the lowest power level setting at which the wireless transmitter can successfully communicate with the wireless communications system is not sufficient to obtain an acceptable location estimate. Therefore, the Wireless Location System can command the wireless communications system to delay its response to these  
5 transmissions by a predetermined time or amount. This delaying action will cause the wireless transmitter to repeat the sequence of steps (i) through (iii) one or more times than normal with the result that one or more of the access transmissions will be at a higher power level than normal. The higher power level may preferably enable the Wireless Location System to determine a more accurate location estimate. The  
10 Wireless Location System may command this type of delaying action for either a particular wireless transmitter, for a particular type of wireless transmission (for example, for all '911' calls), for wireless transmitters that are at a specified range from the base station to which the transmitter is attempting to communicate, or for all wireless transmitters in a particular area.

15  
Send Confirmation to Wireless Transmitter – The Wireless Location System does not include means within to notify the wireless transmitter of an action because the Wireless Location System cannot transmit; as described earlier the Wireless Location System can only receive transmissions. Therefore, if the Wireless Location System  
20 desires to send, for example, a confirmation tone upon the completion of a certain action, the Wireless Location System commands the wireless communications system to transmit a particular message. The message may include, for example, an audible confirmation tone, spoken message, or synthesized message to the wireless transmitter, or a text message sent via a short messaging service or a page. The Wireless Location  
25 System receives confirmation from the wireless communications system that the message has been accepted and sent to the wireless transmitter. This command / response message set is important in enabling the Wireless Location System to support certain end-user application functions such as Prohibit Location Processing.

30 Report Location Records – The Wireless Location System automatically reports location records to the wireless communications system for those wireless transmitters tasked to report to the wireless communications system, as well as for those



transmissions that the wireless communications system initiated triggers. The Wireless Location System also reports on any historical location record queried by the wireless communications system and which the wireless communications system is authorized to receive.

5

Monitor Internal Wireless Communications System Interfaces, State Table

In addition to this above interface between the Wireless Location System and the wireless communications system, the Wireless Location System also includes means to monitor existing interfaces within the wireless communications system for the purpose of intercepting messages important to the Wireless Location System for identifying wireless transmitters and the RF channels in use by these transmitters. These interfaces may include, for example, the "a-interface" and "a-bis interface" used in wireless communications systems employing the GSM air interface protocol. These interfaces are well-known and published in various standards. By monitoring the bi-directional messages on these interfaces between base stations (BTS), base station controllers (BSC), and mobile switching centers (MSC), and other points, the Wireless Location System can obtain the same information about the assignment of wireless transmitters to specific channels as the wireless communications system itself knows. The Wireless Location System includes means to monitor these interfaces at various points. For example, the SCS 10 may monitor a BTS to BSC interface. Alternately, a TLP 12 or AP 14 may also monitor a BSC where a number of BTS to BSC interfaces have been concentrated. The interfaces internal to the wireless communications system are not encrypted and the layered protocols are known to those familiar with the art. The advantage to the Wireless Location System to monitoring these interfaces is that the Wireless Location System may not be required to independently detect and demodulate control channel messages from wireless transmitters. In addition, the Wireless Location System may obtain all necessary voice channel assignment information from these interfaces.

Using these means for a control channel transmission, the SCS 10 receives the transmissions as described earlier and records the control channel RF data into memory without performing detection and demodulation. Separately, the Wireless Location System monitors the messages occurring over prescribed interfaces within the wireless

communications system, and causes a trigger in the Wireless Location System when the Wireless Location System discovers a message containing a trigger event. Initiated by the trigger event, the Wireless Location System determines the approximately time at which the wireless transmission occurred, and commands a first SCS 10 and a second SCS 10B to each search its memory for the start of transmission. This first SCS 10A chosen is an SCS that is either collocated with the base station to which the wireless transmitter had communicated, or an SCS which is adjacent to the base station to which the wireless transmitter had communicated. That is, the first SCS 10A is an SCS which would have been assigned the control channel as a primary channel. If the first SCS 10A successfully determines and reports the start of the transmission, then location processing proceeds normally, using the means described below. If the first SCS 10A cannot successfully determine the start of transmission, then the second SCS 10B reports the start of transmission, and then location processing proceeds normally.

The Wireless Location System also uses these means for voice channel transmissions. For all triggers contained in the Tasking List, the Wireless Location System monitors the prescribed interfaces for messages pertaining to those triggers. The messages of interest include, for example, voice channel assignment messages, handoff messages, frequency hopping messages, power up / power down messages, directed re-try messages, termination messages, and other similar action and status messages. The Wireless Location System continuously maintains a copy of the state and status of these wireless transmitters in a State Table in the AP 14. Each time that the Wireless Location System detects a message pertaining to one of the entries in the Tasking List, the Wireless Location System updates its own State Table. Thereafter, the Wireless Location System may trigger to perform location processing, such as on a regular time interval, and access the State Table to determine precisely which cell site, sector, RF channel, and timeslot is presently being used by the wireless transmitter. The example contained herein described the means by which the Wireless Location System interfaces to a GSM based wireless communications system. The Wireless Location System also supports similar functions with systems based upon other air interfaces.

For certain air interfaces, such as CDMA, the Wireless Location System also keeps certain identity information obtained from Access bursts in the control channel in the State Table; this information is later used for decoding the masks used for voice channels. For example, the CDMA air interface protocol uses the Electronic Serial Number (ESN) of a wireless transmitter to, in part, determine the long code mask used in the coding of voice channel transmissions. The Wireless Location System maintains this information in the State Table for entries in the Tasking List because many wireless transmitters may transmit the information only once; for example, many CDMA mobiles will only transmit their ESN during the first Access burst after the wireless transmitter become active in a geographic area. This ability to independently determine the long code mask is very useful in cases where an interface between the Wireless Location System and the wireless communications system is not operative and/or the Wireless Location System is not able to monitor one of the interfaces internal to the wireless communications system. The operator of the Wireless Location System may optionally set the Wireless Location System to maintain the identity information for all wireless transmitters. In addition to the above reasons, the Wireless Location System can provide the voice channel tracking for all wireless transmitters that trigger location processing by calling "911". As described earlier, the Wireless Location System uses dynamic tasking to provide location to a wireless transmitter for a prescribed time after dialing "911", for example. By maintaining the identity information for all wireless transmitters in the State Table, the Wireless Location System is able to provide voice channel tracking for all transmitters in the event of a prescribed trigger event, and not just those with prior entries in the Tasking List.

#### Applications Interface

Using the AP 14, the Wireless Location System supports a variety of standards based interfaces to end-user and carrier location applications using secure protocols such as TCP/IP, X.25, SS-7, and IS-41. Each interface between the AP 14 and an external application is a secure and authenticated connection that permits the AP 14 to positively verify the identity of the application that is connected to the AP 14. This is necessary because each connected application is granted only limited access to location records on a real-time and/or historical basis. In addition, the AP 14 supports additional command / response, real-time, and post-processing functions that are further detailed below. Access

to these additional functions also requires authentication. The AP 14 maintains a user list and the authentication means associated with each user. No application can gain access to location records or functions for which the application does not have proper authentication or access rights. In addition, the AP 14 supports full logging of all actions taken by each application in the event that problems arise or a later investigation into actions is required. For each command or function in the list below, the AP 14 preferably supports a protocol in which each action or the result of each is confirmed, as appropriate.

10 Edit Tasking List – This command permits external applications to add, remove, or edit entries in the Tasking List, including any fields and flags associated with each entry. This command can be supported on a single entry basis, or a batch entry basis where a list of entries is included in a single command. The latter is useful, for example, in a bulk application such as location sensitive billing whereby larger volumes of wireless transmitters are being supported by the external application, and it is desired to minimize protocol overhead. This command can add or delete applications for a particular entry in the Tasking List, however, this command cannot delete an entry entirely if the entry also contains other applications not associated with or authorized by the application issuing the command.

20 Set Location Interval – The Wireless Location System can be set to perform location processing at any interval for a particular wireless transmitter, on either control or voice channels. For example, certain applications may require the location of a wireless transmitter every few seconds when the transmitter is engaged on a voice channel. When the wireless transmitter make an initial transmission, the Wireless Location System initially triggers using a standard entry in the Tasking List. If one of the fields or flags in this entry specifies updated location on a set interval, then the Wireless Location System creates a dynamic task in the Tasking List that is triggered by a timer instead of an identity or other transmitted criteria. Each time the timer expires, which can range from 1 second to several hours, the Wireless Location System will automatically trigger to locate the wireless transmitter. The Wireless Location System uses its interface to the wireless communications system to query status of the wireless transmitter, including voice call parameters as described earlier.

If the wireless transmitter is engaged on a voice channel, then the Wireless Location System performs location processing. If the wireless transmitter is not engaged in any existing transmissions, the Wireless Location System will command the wireless communications system to make the wireless transmitter immediately transmit. When  
5 the dynamic task is set, the Wireless Location System also sets an expiration time at which the dynamic task ceases.

End-User Addition / Deletion – This command can be executed by an end-user of a wireless transmitter to place the identity of the wireless transmitter onto the Tasking  
10 List with location processing enabled, to remove the identity of the wireless transmitter from the Tasking List and therefore eliminate identity as a trigger, or to place the identity of the wireless transmitter onto the Tasking List with location processing disabled. When location processing has been disabled by the end-user, known as Prohibit Location Processing then no location processing will be performed for the  
15 wireless transmitter. The operator of the Wireless Location System can optionally select one of several actions by the Wireless Location System in response to a Prohibit Location Processing command by the end user: (i) the disabling action can override all other triggers in the Tasking List, including a trigger due to an emergency call such as “911”, (ii) the disabling action can override any other trigger in the Tasking List,  
20 except a trigger due to an emergency call such as “911”, (iii) the disabling action can be overridden by other select triggers in the Tasking List. In the first case, the end-user is granted complete control over the privacy of the transmissions by the wireless transmitter, as no location processing will be performed on that transmitter for any reason. In the second case, the end-user may still receive the benefits of location  
25 during an emergency, but at no other times. In an example of the third case, an employer who is the real owner of a particular wireless transmitter can override an end-user action by an employee who is using the wireless transmitter as part of the job but who may not desire to be located. The Wireless Location System may query the wireless communications system, as described above, to obtain the mapping of the  
30 identity contained in the wireless transmission to other identities.

The additions and deletions by the end-user are effected by dialed sequences of characters and digits and pressing the "SEND" or equivalent button on the wireless transmitter. These sequences may be optionally chosen and made known by the operator of the Wireless Location System. For example, one sequence may be "\*55  
5 SEND" to disable location processing. Other sequences are also possible. When the end-user can dialed this prescribed sequence, the wireless transmitter will transmit the sequence over one of the prescribed control channels of the wireless communications system. Since the Wireless Location System independently detects and demodulates all reverse control channel transmissions, the Wireless Location System can  
10 independently interpret the prescribed dialed sequence and make the appropriate feature updates to the Tasking List, as described above. When the Wireless Location System has completed the update to the Tasking List, the Wireless Location System commands the wireless communications system to send a confirmation to the end-user. As described earlier, this may take the form of an audible tone, recorded or  
15 synthesized voice, or a text message. This command is executed over the interface between the Wireless Location System and the wireless communications system.

Command Transmit – This command allows external applications to cause the Wireless Location System to send a command to the wireless communications system  
20 to make a particular wireless transmitter, or group of wireless transmitters, transmit. This command may contain a flag or field that the wireless transmitter(s) should transmit immediately or at a prescribed time. This command has the effort of locating the wireless transmitter(s) upon command, since the transmissions will be detected, demodulated, and triggered, causing location processing and the generation of a  
25 location record. This is useful in eliminating or reducing any delay in determining location such as waiting for the next registration time period for the wireless transmitter or waiting for an independent transmission to occur.

External Database Query and Update – The Wireless Location System includes means  
30 to access an external database, to query the said external database using the identity of the wireless transmitter or other parameters contained in the transmission or the trigger criteria, and to merge the data obtained from the external database with the data

generated by the Wireless Location System to create a new enhanced location record. The enhanced location record may then be forwarded to requesting applications. The external database may contain, for example, data elements such as customer information, medical information, subscribed features, application related information, customer account information, contact information, or sets of prescribed actions to take upon a location trigger event. The Wireless Location System may also cause updates to the external database, for example, to increment or decrement a billing counter associated with the provision of location services, or to update the external database with the latest location record associated with the particular wireless transmitter. The Wireless Location System contains means to performed the actions described herein on more than one external database. The list and sequence of external databases to access and the subsequent actions to take are contained in one of the fields contained in the trigger criteria in the Tasking List.

Random Anonymous Location Processing – The Wireless Location System includes means to perform large scale random anonymous location processing. This function is valuable to certain types of applications that require the gathering of a large volume of data about a population of wireless transmitters without consideration to the specific identities of the individual transmitters. Applications of this type include: RF Optimization, which enables wireless carriers to measure the performance of the wireless communications system by simultaneously determining location and other parameters of a transmission; Traffic Management, which enables government agencies and commercial concerns to monitor the flow of traffic on various highways using statistically significant samples of wireless transmitters travelling in vehicles; and Local Traffic Estimation, which enables commercial enterprises to estimate the flow of traffic around a particular area which may help determine the viability of particular businesses.

Applications requesting random anonymous location processing optionally receive location records from two sources: (i) a copy of location records generated for other applications, and (ii) location records which have been triggered randomly by the Wireless Location System without regard to any specific criteria. All of the location

records generated from either source are forwarded with all of the identity and trigger criteria information removed from the location records; however, the requesting application(s) can determine whether the record was generated from the fully random process or is a copy from another trigger criteria. The random location records are  
5 generated by a low priority task within the Wireless Location System that performs location processing on randomly selected transmissions whenever processing and communications resources are available and would otherwise be unused at a particular instant in time. The requesting application(s) can specify whether the random location processing is performed over the entire coverage area of a Wireless Location System,  
10 over specific geographic areas such as along prescribed highways, or by the coverage areas of specific cell sites. Thus, the requesting application(s) can direct the resources of the Wireless Location System to those area of greatest interest to each application. Depending on the randomness desired by the application(s), the Wireless Location System can adjust preferences for randomly selecting certain types of transmissions,  
15 for example, registration messages, origination messages, page response messages, or voice channel transmissions.

Anonymous Tracking of a Geographic Group – The Wireless Location System includes means to trigger location processing on a repetitive basis for anonymous  
20 groups of wireless transmitters within a prescribed geographic area. For example, a particular location application may desire to monitor the travel route of a wireless transmitter over a prescribed period of time, but without the Wireless Location System disclosing the particular identity of the wireless transmitter. The period of time may be many hours, days, or weeks. Using the means, the Wireless Location System:  
25 randomly selects a wireless transmitter that initiates a transmission in the geographic area of interest to the application; performs location processing on the transmission of interest; irreversibly translates and encrypts the identity of the wireless transmitter into a new coded identifier; creates a location record using only the new coded identifier as an identifying means; forwards the location record to the requesting location  
30 application(s); and creates a dynamic task in the Tasking List for the wireless transmitter, where the dynamic task has an associated expiration time. Subsequently, whenever the prescribed wireless transmitter initiates transmission, the Wireless



Location System shall trigger using the dynamic task, perform location processing on the transmission of interest, irreversibly translate and encrypt the identity of the wireless transmitter into the new coded identifier using the same means as prior such that the coded identifier is the same, create a location record using the coded identifier, and forward the location record to the requesting location application(s). The means described herein can be combined with other functions of the Wireless Location System to perform this type of monitoring use either control or voice channel transmissions. Further, the means described herein completely preserve the private identity of the wireless transmitter, yet enables another class of applications that can monitor the travel patterns of wireless transmitters. This class of applications can be of great value in determining the planning and design of new roads, alternate route planning, or the construction of commercial and retail space.

Location Record Grouping, Sorting, and Labeling – The Wireless Location System include means to post-process the location records for certain requesting applications to group, sort, or label the location records. For each interface supported by the Wireless Location System, the Wireless Location System stores a profile of the types of data for which the application is both authorized and requesting, and the types of filters or post-processing actions desired by the application. Many applications, such as the examples contained herein, do not require individual location records or the specific identities of individual transmitters. For example, an RF optimization application derives more value from a large data set of location records for a particular cell site or channel than it can from any individual location record. For another example, a traffic monitoring application requires only location records from transmitters that are on prescribed roads or highways, and additionally requires that these records be grouped by section of road or highway and by direction of travel. Other applications may request that the Wireless Location System forward location records that have been formatted to enhance visual display appeal by, for example, adjusting the location estimate of the transmitter so that the transmitter's location appears on an electronic map directly on a drawn road segment rather than adjacent to the road segment. Therefore, the Wireless Location System preferably "snaps" the location estimate to the nearest drawn road segment.

The Wireless Location System can filter and report location records to an application for wireless transmitters communicating only on a particular cell site, sector, RF channel, or group of RF channels. Before forwarding the record to the requesting application, the Wireless Location System first verifies that the appropriate fields in the record satisfy the requirements. Records not matching the requirements are not forwarded, and records matching the requirements are forwarded. Some filters are geographic and must be calculated by the Wireless Location System. For example, the Wireless Location System can process a location record to determine the closest road segment and direction of travel of the wireless transmitter on the road segment. The Wireless Location System can then forward only records to the application that are determined to be on a particular road segment, and can further enhance the location record by adding a field containing the determined road segment. In order to determine the closest road segment, the Wireless Location System is provided with a database of road segments of interest by the requesting application. This database is stored in a table where each road segment is stored with a latitude and longitude coordinate defining the end point of each segment. Each road segment can be modeled as a straight or curved line, and can be modeled to support one or two directions of travel. Then for each location record determined by the Wireless Location System, the Wireless Location System compares the latitude and longitude in the location record to each road segment stored in the database, and determines the shortest distance from a modeled line connecting the end points of the segment to the latitude and longitude of the location record. The shortest distance is a calculated imaginary line orthogonal to the line connecting the two end points of the stored road segment. When the closest road segment has been determined, the Wireless Location System can further determine the direction of travel on the road segment by comparing the direction of travel of the wireless transmitter reported by the location processing to the orientation of the road segment. The direction that produces the smallest error with respect to the orientation of the road segments is then reported by the Wireless Location System.

30

Network Operations Console (NOC) 16

The NOC 16 is a network management system that permits operators of the Wireless Location System easy access to the programming parameters of the Wireless Location System. For example, in some cities, the Wireless Location System may contain many  
5 hundreds or even thousands of SCS's 10. The NOC is the most effective way to manage a large Wireless Location System, using graphical user interface capabilities. The NOC will also receive real time alerts if certain functions within the Wireless Location System are not operating properly. These real time alerts can be used by the operator to take  
10 corrective action quickly and prevent a degradation of location service. Experience with trials of the Wireless Location System show that the ability of the system to maintain good location accuracy over time is directly related to the operator's ability to keep the system operating within its predetermined parameters.

Location Processing

15 The Wireless Location System is capable of performing location processing using two different methods known as central based processing and station based processing. Both techniques were first disclosed in Patent Number 5,327,144, and are further enhanced in this specification. Location processing depends in part on the ability to accurately  
20 determine certain phase characteristics of the signal as received at multiple antennas and at multiple SCS's 10. Therefore, it is an object of the Wireless Location System to identify and remove sources of phase error that impede the ability of the location processing to determine the phase characteristics of the received signal. One source of phase error is inside of the wireless transmitter itself, namely the oscillator (typically a crystal oscillator) and the phase lock loops that allow the phone to tune to specific channels for transmitting.  
25 Lower cost crystal oscillators will generally have higher phase noise. Some air interface specifications, such as IS-136 and IS-95A, have specifications covering the phase noise with which a wireless telephone can transmit. Other air interface specifications, such as IS-553A, do not closely specify phase noise. It is therefore an object of the present invention to automatically reduce and/or eliminate a wireless transmitter's phase noise as a  
30 source of phase error in location processing, in part by automatically selecting the use of central based processing or station based processing. The automatic selection will also

consider the efficiency with which the communications link between the SCS 10 and the TLP 12 is used, and the availability of DSP resources at each of the SCS 10 and TLP 12.

When using central based processing, the TDOA and FDOA determination and the  
5 multipath processing are performed in the TLP 12 along with the position and speed  
determination. This method is preferred when the wireless transmitter has a phase noise  
that is above a predetermined threshold. In these cases, central based processing is most  
effective in reducing or eliminating the phase noise of the wireless transmitter as a source  
of phase error because the TDOA estimate is performed using a digital representation of  
10 the actual RF transmission from two antennas, which may be at the same SCS 10 or  
different SCS's 10. In this method, those skilled in the art will recognize that the phase  
noise of the transmitter is a common mode noise in the TDOA processing, and therefore is  
self-canceling in the TDOA determination process. This method works best, for example,  
with many very low cost AMPS cellular telephones that have a high phase noise. The  
15 basic steps in central based processing include the steps recited below and represented in  
the flowchart of Figure 6:

a wireless transmitter initiates a transmission on either a control channel or a voice  
channel (step S50);  
20 the transmission is received at multiple antennas and at multiple SCS's 10 in the  
Wireless Location System (step S51);  
the transmission is converted into a digital format in the receiver connected to each  
SCS/antenna (step S52);  
the digital data is stored in a memory in the receivers in each SCS 10 (step S53);  
25 the transmission is demodulated (step S54);  
the Wireless Location System determines whether to begin location processing for the  
transmission (step S55);  
if triggered, the TLP 12 requests copies of the digital data from the memory in receivers  
at multiple SCS's 10 (step S56);  
30 digital data is sent from multiple SCS's 10 to a selected TLP 12 (step S57);  
the TLP 12 performs TDOA, FDOA, and multipath mitigation on the digital data from  
pairs of antennas (step S58);

the TLP 12 performs position and speed determination using the TDOA data, and then creates a location record and forwards the location record to the AP 14 (step S59).

5 The Wireless Location System uses a variable number of bits to represent the transmission when sending digital data from the SCS's 10 to the TLP 12. As discussed earlier, the SCS receiver digitizes wireless transmissions with a high resolution, or a high number of bits per digital sample in order to achieve a sufficient dynamic range. This is especially required when using wideband digital receivers, which may be simultaneously receiving signals near to the SCS 10A and far from the SCS 10B. For example, up to 14 bits may be  
10 required to represent a dynamic range of 84 dB. Location processing does not always require the high resolution per digital sample, however. Frequently, locations of sufficient accuracy are achievable by the Wireless Location System using a fewer number of bits per digital sample. Therefore, to minimize the implementation cost of the Wireless Location System by conserving bandwidth on the communication links between each SCS 10 and  
15 TLP 12, the Wireless Location System determines the fewest number of bits required to digitally represent a transmission while still maintaining a desired accuracy level. This determination is based, for example, on the particular air interface protocol used by the wireless transmitter, the SNR of the transmission, the degree to which the transmission has been perturbed by fading and/or multipath, and the current state of the processing and  
20 communication queues in each SCS 10. The number of bits sent from the SCS 10 to the TLP 12 are reduced in two ways: the number of bits per sample is minimized, and the shortest length, or fewest segments, of the transmission possible is used for location processing. The TLP 12 can use this minimal RF data to perform location processing and then compare the result with the desired accuracy level. This comparison is performed on  
25 the basis of a confidence interval calculation. If the location estimate does not fall within the desired accuracy limits, the TLP 12 will recursively request additional data from selected SCS's 10. The additional data may include an additional number of bits per digital sample and/or may include more segments of the transmission. This process of requesting additional data may continue recursively until the TLP 12 has achieved the  
30 prescribed location accuracy.

There are additional details to the basic steps described above. These details are described in prior Patent Numbers 5,327,144 and 5,608,410 in other parts of this specification. One enhancement to the processes described in earlier patents is the selection of a single reference SCS/antenna that is used for each baseline in the location processing. In prior art, baselines were determined using pairs of antenna sites around a ring. In the present  
 5 Wireless Location System, the single reference SCS/antenna used is generally the highest SNR signal, although other criteria are also used as described below. The use of a high SNR reference aids central based location processing when the other SCS/antennas used in the location processing are very weak, such as at or below the noise floor (i.e. zero or  
 10 negative signal to noise ratio). When station based location processing is used, the reference signal is a re-modulated signal, which is intentionally created to have a very high signal to noise ratio, further aiding location processing for very weak signals at other SCS/antennas. The actual selection of the reference SCS/antenna is described below.

15 The Wireless Location System mitigates multipath by first recursively estimating the components of multipath received in addition to the direct path component and then subtracting these components from the received signal. Thus the Wireless Location System models the received signal and compares the model to the actual received signal and attempts to minimize the difference between the two using a weighted least square  
 20 difference. For each transmitted signal  $x(t)$  from a wireless transmitter, the received signal  $y(t)$  at each SCS/antenna is a complex combination of signals:

$$y(t) = \sum x(t - \tau_n) a_n e^{j\omega(t - \tau_n)}, \text{ for all } n = 0 \text{ to } N;$$

25 where  $x(t)$  is the signal as transmitted by the wireless transmitter;  
 $a_n$  and  $\tau_n$  are the complex amplitude and delays of the multipath components;  
 $N$  is the total number of multipath components in the received signal; and  
 $a_0$  and  $\tau_0$  are constants for the most direct path component.

30 The operator of the Wireless Location System empirically determines a set of constraints for each component of multipath that applies to the specific environment in which each Wireless Location System is operating. The purpose of the constraints is to limit the

amount of processing time that the Wireless Location System spends optimizing the results for each multipath mitigation calculation. For example, the Wireless Location System may be set to determine only four components of multipath: the first component may be assumed to have a time delay in the range  $\tau_{1A}$  to  $\tau_{1B}$ ; the second component may  
5 be assumed to have a time delay in the range  $\tau_{2A}$  to  $\tau_{2B}$ ; the third component may be assumed to have a time delay in the range  $\tau_{3A}$  to  $\tau_{3B}$ ; and similar for the fourth component; however the fourth component is a single value that effectively represents a complex combination of many tens of individual (and somewhat diffuse) multipath components whose time delays exceed the range of the third component. For ease of  
10 processing, the Wireless Location System transforms the prior equation into the frequency domain, and then solves for the individual components such that a weighted least squares difference is minimized.

When using station based processing, the TDOA and FDOA determination and multipath  
15 mitigation are performed in the SCS's 10, while the position and speed determination are typically performed in the TLP 12. The main advantage of station based processing, as described in Patent Number 5,327,144, is reducing the amount of data that is sent on the communication link between each SCS 10 and TLP 12. However, there may be other advantages as well. One new objective of the present invention is increasing the effective  
20 signal processing gain during the TDOA processing. As pointed out earlier, central based processing has the advantage of eliminating or reducing phase error caused by the phase noise in the wireless transmitter. However, no previous disclosure has addressed how to eliminate or reduce the same phase noise error when using station based processing. The present invention reduces the phase error and increases the effective signal processing gain  
25 using the steps recited below and shown in Figure 6:

a wireless transmitter initiates a transmission on either a control channel or a voice channel (step S60);  
the transmission is received at multiple antennas and at multiple SCS's 10 in the  
30 Wireless Location System (step S61);  
the transmission is converted into a digital format in the receiver connected to each antenna (step S62);

the digital data is stored in a memory in the SCS 10 (step S63);  
the transmission is demodulated (step S64);  
the Wireless Location System determines whether to begin location processing for the  
transmission (step S65);  
5 if triggered, a first SCS 10A demodulates the transmission and determines an  
appropriate phase correction interval (step S66);  
for each such phase correction interval, the first SCS 10A calculates an appropriate  
phase correction and amplitude correction, and encodes this phase correction  
parameter and amplitude correction parameter along with the demodulated data (step  
10 S67);  
the demodulated data and phase correction and amplitude correction parameters are sent  
from the first SCS 10A to a TLP 12 (step S68);  
the TLP 12 determines the SCS's 10 and receiving antennas to use in the location  
processing (step S69);  
15 the TLP 12 sends the demodulated data and phase correction and amplitude correction  
parameters to each second SCS 10B that will be used in the location processing (step  
S70);  
the first SCS 10 and each second SCS 10B creates a first re-modulated signal based  
upon the demodulated data and the phase correction and amplitude correction  
20 parameters (step S71);  
the first SCS 10A and each second SCS 10B performs TDOA, FDOA, and multipath  
mitigation using the digital data stored in memory in each SCS 10 and the first re-  
modulated signal (step S72);  
the TDOA, FDOA, and multipath mitigation data are sent from the first SCS 10A and  
25 each second SCS 10B to the TLP 12 (step S73);  
the TLP 12 performs position and speed determination using the TDOA data (step S74);  
and  
the TLP 12 creates a location record, and forwards the location record to the AP 14 (step  
S75).

30

The advantages of determining phase correction and amplitude correction parameters are most obvious in the location of CDMA wireless transmitters based upon IS-95A. As is



well known, the reverse transmissions from an IS-95A transmitter are sent using non-coherent modulation. Most CDMA base stations only integrate over a single bit interval because of the non-coherent modulation. For a CDMA Access Channel, with a bit rate of 4800 bits per second, there are 256 chips sent per bit, which permits an integration gain of 24 dB. Using the technique described above, the TDOA processing in each SCS 10 may integrate, for example, over a full 160 millisecond burst (196,608 chips) to produce an integration gain of 53 dB. This additional processing gain enables the present invention to detect and locate CDMA transmissions using multiple SCS's 10, even if the base stations collocated with the SCS's 10 cannot detect the same CDMA transmission.

10

For a particular transmission, if either the phase correction parameters or the amplitude correction parameters are calculated to be zero, or are not needed, then these parameters are not sent in order to conserve on the number of bits transmitted on the communications link between each SCS 10 and TLP 12. In another embodiment of the invention, the Wireless Location System may use a fixed phase correction interval for a particular transmission or for all transmissions of a particular air interface protocol, or for all transmissions made by a particular type of wireless transmitter. This may, for example, be based upon empirical data gathered over some period of time by the Wireless Location System showing a reasonable consistency in the phase noise exhibited by various classes of transmitters. In these cases, the SCS 10 may save the processing step of determining the appropriate phase correction interval.

15

Those skilled in the art will recognize that there are many ways of measuring the phase noise of a wireless transmitter. In one embodiment, a pure, noiseless re-modulated copy of the signal received at the first SCS 10A may be digitally generated by DSP's in the SCS, then the received signal may be compared against the pure signal over each phase correction interval and the phase difference may be measured directly. In this embodiment, the phase correction parameter will be calculated as the negative of the phase difference over that phase correction interval. The number of bits required to represent the phase correction parameter will vary with the magnitude of the phase correction parameter, and the number of bits may vary for each phase correction interval. It has been

20

25

30

observed that some transmissions, for example, exhibit greater phase noise early in the transmission, and less phase noise in the middle of and later in the transmission.

5 Station based processing is most useful for wireless transmitters that have relatively low phase noise. Although not necessarily required by their respective air interface standards, wireless telephones that use the TDMA, CDMA, or GSM protocols will typically exhibit lower phase noise. As the phase noise of a wireless transmitter increases, the length of a phase correction interval may decrease and/or the number of bits required to represent the phase correction parameters increases. Station based processing is not effective when the  
10 number of bits required to represent the demodulated data plus the phase correction and amplitude parameters exceeds a predetermined proportion of the number of bits required to perform central based processing. It is therefore an object of the present invention to automatically determine for each transmission for which a location is desired whether to process the location using central based processing or station based processing. The steps  
15 in making this determination are recited below and shown in Figure 7:

a wireless transmitter initiates a transmission on either a control channel or a voice channel (step S80);  
the transmission is received at a first SCS 10A (step S81);  
20 the transmission is converted into a digital format in the receiver connected to each antenna (step S82);  
the Wireless Location System determines whether to begin location processing for the transmission (step S83);  
if triggered, a first SCS 10A demodulates the transmission and estimates an appropriate  
25 phase correction interval and the number of bits required to encode the phase correction and amplitude correction parameters (step S84);  
the first SCS 10A then estimates the number of bits required for central based processing;  
based upon the number of bits required for each respective method, the SCS 10 or the  
30 TLP 12 determine whether to use central based processing or station based processing to perform the location processing for this transmission (step S85).

In another embodiment of the invention, the Wireless Location System may always use central based processing or station based processing for all transmissions of a particular air interface protocol, or for all transmissions made by a particular kind of wireless transmitter. This may, for example, be based upon empirical data gathered over some  
5 period of time by the Wireless Location System showing a reasonable consistency in the phase noise exhibited by various classes of transmitters. In these cases, the SCS 10 and/or the TLP 12 may be saved the processing step of determining the appropriate processing method.

10 A further enhancement of the present invention, used for both central based processing and station based processing, is the use of threshold criteria for including baselines in the final determination of location and velocity of the wireless transmitter. For each baseline, the Wireless Location System calculates a number of parameters that include: the SCS/antenna port used with the reference SCS/antenna in calculating the baseline, the  
15 peak, average, and variance in the power of the transmission as received at the SCS/antenna port used in the baseline and over the interval used for location processing, the correlation value from the cross-spectra correlation between the SCS/antenna used in the baseline and the reference SCS/antenna, the delay value for the baseline, the multipath mitigation parameters, the residual values remaining after the multipath mitigation  
20 calculations, the contribution of the SCS/antenna to the weighted GDOP in the final location solution, and a measure of the quality of fit of the baseline if included in the final location solution. Each baseline is included in the final location solution is each meets or exceeds the threshold criteria for each of the parameters described herein. A baseline may be excluded from the location solution if it fails to meet one or more of the threshold  
25 criteria. Therefore, it is frequently possible that the number of SCS/antennas actually used in the final location solution is less than the total number considered.

Previous Patent Numbers 5,327,144 and 5,608,410 disclosed a method by which the location processing minimized the least square difference (LSD) value of the following  
30 equation:

$$\text{LSD} = [Q_{12}(\text{Delay\_T}_{12}-\text{Delay\_O}_{12})^2 + Q_{13}(\text{Delay\_T}_{13}-\text{Delay\_O}_{13})^2 + \dots + Q_{xy}(\text{Delay\_T}_{xy}-\text{Delay\_O}_{xy})^2]$$

In the present implementation, this equation has been rearranged to the following form in order to make the location processing code more efficient:

$$\text{LSD} = \Sigma (\text{TDOA}_{0i} - \tau_i + \tau_0)^2 w_i^2; \text{ over all } i=1 \text{ to } N-1$$

where N = number of SCS/antennas used in the location processing;

10  $\text{TDOA}_{0i}$  = the TDOA to the  $i^{\text{th}}$  site from reference site 0;

$\tau_i$  = the theoretical line of sight propagation time from the wireless transmitter to the  $i^{\text{th}}$  site;

$\tau_0$  = the theoretical line of sight propagation time from the transmitter to the reference; and

$w_i$  = the weight, or quality factor, applied to the  $i^{\text{th}}$  baseline.

15

In the present implementation, the Wireless Location System also uses another alternate form of the equation that can aid in determining location solutions when the reference signal is not very strong or when it is likely that a bias would exist in the location solution using the prior form of the equation:

20

$$\text{LSD}' = \Sigma (\text{TDOA}_{0i} - \tau_i)^2 w_i^2 - b^2 \Sigma w_i^2; \text{ over all } i=0 \text{ to } N-1$$

Where N = number of SCS/antennas used in the location processing;

$\text{TDOA}_{0i}$  = the TDOA to the  $i^{\text{th}}$  site from reference site 0;

25  $\text{TDOA}_{00}$  = is assumed to be zero;

$\tau_i$  = the theoretical line of sight propagation time from the wireless transmitter to the  $i^{\text{th}}$  site;

b = a bias that is separately calculated for each theoretical point that minimizes LSD' at that theoretical point; and

30  $w_i$  = the weight, or quality factor, applied to the  $i^{\text{th}}$  baseline.

The LSD' form of the equation offers an easier means of removing a bias in location solutions at the reference site by making  $w_0$  equal to the maximum value of the other weights or basing  $w_0$  on the relative signal strength at the reference site. Note that if  $w_0$  is much larger than the other weights, then  $b$  is approximately equal to  $\tau_0$ . In general, the weights, or quality factors are based on similar criteria to that discussed above for the threshold criteria in including baselines. That is, the results of the criteria calculations are used for weights and when the criteria falls below threshold the weight is then set to zero and is effectively not included in the determination of the final location solution.

10 Antenna Selection Process for Location Processing

Previous inventions and disclosures, such as those listed above, have described techniques in which a first, second, or possibly third antenna site, cell site, or base station are required to determine location. Patent number 5,608,410 further discloses a Dynamic Selection Subsystem (DSS) that is responsible for determining which data frames from which antenna site locations will be used to calculate the location of a responsive transmitter. In the DSS, if data frames are received from more than a threshold number of sites, the DSS determines which are candidates for retention or exclusion, and then dynamically organizes data frames for location processing. The DSS prefers to use more than the minimum number of antenna sites so that the solution is over-determined. Additionally, the DSS assures that all transmissions used in the location processing were received from the same transmitter and from the same transmission.

The preferred embodiments of the prior inventions had several limitations, however. First, either only one antenna per antenna site (or cell site) is used, or the data from two or four diversity antennas were first combined at the antenna site (or cell site) prior to transmission to the central site. Additionally, all antenna sites that received the transmission sent data frames to the central site, even if the DSS later discarded the data frames. Thus, some communications bandwidth may have been wasted sending data that was not used.

30 The present inventors have determined that while a minimum of two or three sites are required in order determine location, the actual selection of antennas and SCS's 10 to use

in location processing can have a significant effect on the results of the location processing. In addition, it is advantageous to include the means to use more than one antenna at each SCS 10 in the location processing. The reason for using data from multiple antennas at a cell site independently in the location processing is that the signal received at each antenna is uniquely affected by multipath, fading, and other disturbances. It is well known in the field that when two antennas are separated in distance by more than one wavelength, then each antenna will receive the signal on an independent path. Therefore, there is frequently additional and unique information to be gained about the location of the wireless transmitter by using multiple antennas, and the ability of the Wireless Location System to mitigate multipath is enhanced accordingly.

It is therefore an object of the present invention to provide an improved method for using the signals received from more than one antenna at an SCS 10 in the location processing. It is a further object to provide a method to improve the dynamic process used to select the cooperating antennas and SCS's 10 used in the location processing. The first object is achieved by providing means within the SCS 10 to select and use any segment of data collected from any number of antennas at an SCS in the location processing. As described earlier, each antenna at a cell site is connected to a receiver internal to the SCS 10. Each receiver converts signals received from the antenna into a digital form, and then stores the digitized signals temporarily in a memory in the receiver. The TLP 12 has been provided with means to direct any SCS 10 to retrieve segments of data from the temporary memory of any receiver, and to provide the data for use in location processing. The second object is achieved by providing means within the Wireless Location System to monitor a large number of antennas for reception of the transmission that the Wireless Location System desires to locate, and then selecting a smaller set of antennas for use in location processing based upon a predetermined set of parameters. One example of this selection process is represented by the flowchart of Figure 8:

a wireless transmitter initiates a transmission on either a control channel or a voice channel (step S90);  
the transmission is received at multiple antennas and at multiple SCS's 10 in the Wireless Location System (step S91);

the transmission is converted into a digital format in the receiver connected to each antenna (step S92);  
the digital data is stored in a memory in each SCS 10 (step S93);  
the transmission is demodulated at at least one SCS 10A and the channel number on  
5 which the transmission occurred and the cell site and sector serving the wireless transmitter is determined (step S94);  
based upon the serving cell site and sector, one SCS 10A is designated as the 'primary' SCS 10 for processing that transmission (step S95);  
the primary SCS 10A determines a timestamp associated with the demodulated data  
10 (step S96);  
the Wireless Location System determines whether to begin location processing for the transmission (step S97);  
if location processing is triggered, the Wireless Location System determines a candidate list of SCS's 10 and antennas to use in the location processing (step S98);  
15 each candidate SCS/antenna measures and reports several parameters in the channel number of the transmission and at the time of the timestamp determined by the primary SCS 10A (step S99);  
the Wireless Location System orders the candidate SCS/antennas using specified criteria and selects a reference SCS/antenna and a processing list of SCS/antennas to use in the  
20 location processing (step S100); and  
the Wireless Location System proceeds with location processing as described earlier, using data from the processing list of SCS/antennas (step S101).

#### Selecting Primary SCS/Antenna

25 The process for choosing the 'primary' SCS/antenna is critical, because the candidate list of SCS's 10 and antennas 10-1 is determined in part based upon the designation of the primary SCS/antenna. When a wireless transmitter makes a transmission on a particular RF channel, the transmission frequently can propagate many miles before the signal attenuates below a level at which it can be demodulated. Therefore, there are frequently  
30 many SCS/antennas capable of demodulating the signal. This especially occurs in urban and suburban areas where the frequency re-use pattern of many wireless communications systems can be quite dense. For example, because of the high usage rate of wireless and

the dense cell site spacing, the present inventors have tested wireless communications systems in which the same RF control channel and digital color code were used on cell sites spaced about one mile apart. Because the Wireless Location System is independently demodulating these transmissions, the Wireless Location System frequently can  
5 demodulate the same transmission at two, three, or more separate SCS/antennas. The Wireless Location System detects that the same transmission has been demodulated multiple times at multiple SCS/antennas when the Wireless Location System receives multiple demodulated data frames sent from different SCS/antennas, each with a number of bit errors below a predetermined bit error threshold, and with the demodulated data  
10 matching within an acceptable limit of bit errors, and all occurring within a predetermined interval of time.

When the Wireless Location System detects demodulated data from multiple SCS/antennas, it examines the following parameters to determine which SCS/antenna shall  
15 be designated the primary SCS: average SNR over the transmission interval used for location processing, the variance in the SNR over the same interval, correlation of the beginning of the received transmission against a pure pre-cursor (i.e. for AMPS, the dotting and Barker code), the number of bit errors in the demodulated data, and the magnitude and rate of change of the SNR from just before the on-set of the transmission to  
20 the on-set of the transmission, as well as other similar parameters. The average SNR is typically determined at each SCS/antenna either over the entire length of the transmission to be used for location processing, or over a shorter interval. The average SNR over the shorter interval can be determined by performing a correlation with the dotting sequence and/or Barker code and/or sync word, depending on the particular air interface protocol,  
25 and over a short range of time before, during, and after the timestamp reported by each SCS 10. The time range may typically be +/-200 microseconds centered at the timestamp, for example. The Wireless Location System will generally order the SCS/antennas using the following criteria, each of which may be weighted (multiplied by an appropriate factor) when combining the criteria to determine the final decision: SCS/antennas with a  
30 lower number of bit errors are preferred to SCS/antennas with a higher number of bit errors, average SNR for a given SCS/antenna must be greater than a predetermined threshold to be designated as the primary; SCS/antennas with higher average SNR are



preferred over those with lower average SNR; SCS/antennas with lower SNR variance are preferred to those with higher SNR variance; and SCS/antennas with a faster SNR rate of change at the on-set of the transmission are preferred to those with a slower rate of change. The weighting applied to each of these criteria may be adjusted by the operator of the  
5 Wireless Location System to suit the particular design of each system.

The candidate list of SCS's 10 and antennas 10-1 are selected using a predetermined set of criteria based, for example, upon knowledge of the types of cell sites, types of antennas at the cell sites, geometry of the antennas, and a weighting factor that weights certain  
10 antennas more than other antennas. The weighting factor takes into account knowledge of the terrain in which the Wireless Location System is operating, past empirical data on the contribution of each antenna has made to good location estimates, and other factors that may be specific to each different WLS installation. In one embodiment, for example, the Wireless Location System may select the candidate list to include all SCS's 10 up to a  
15 maximum number of sites (`max_number_of_sites`) that are closer than a predefined maximum radius from the primary site (`max_radius_from_primary`). For example, in an urban or suburban environment, where there may be a large number of cell sites, the `max_number_of_sites` may be limited to nineteen. Nineteen sites would include the primary, the first ring of six sites surrounding the primary (assuming a classic hexagonal  
20 distribution of cell sites), and the next ring of twelve sites surrounding the first ring. This is depicted in Figure 9. In another embodiment, in a suburban or rural environment, `max_radius_from_primary` may be set to 40 miles to ensure that the widest possible set of candidate SCS/antennas is available. The Wireless Location System is provided with means to limit the total number of candidate SCS's 10 to a maximum number  
25 (`max_number_candidates`), although each candidate SCS may be permitted to choose the best port from among its available antennas. This limits the maximum time spent by the Wireless Location System processing a particular location. `Max_number_candidates` may be set to thirty-two, for example, which means that in a typical three sector wireless communications system with diversity, up to  $32 * 6 = 192$  total antennas could be  
30 considered for location processing for a particular transmission. In order to limit the time spent processing a particular location, the Wireless Location System is provided with means to limit the number of antennas used in the location processing to

max\_number\_antennas\_processed. Max\_number\_antennas\_processed is generally less than max\_number\_candidates, and is typically set to sixteen.

5 While the Wireless Location System is provided with the ability to dynamically determine the candidate list of SCS's 10 and antennas based upon the predetermined set of criteria described above, the Wireless Location System can also store a fixed candidate list in a table. Thus, for each cell site and sector in the wireless communications system, the Wireless Location System has a separate table that defines the candidate list of SCS's 10 and antennas 10-1 to use whenever a wireless transmitter initiates a transmission in that  
10 cell site and sector. Rather than dynamically choose the candidate SCS/antennas each time a location request is triggered, the Wireless Location System reads the candidate list directly from the table when location processing is initiated.

In general, a large number of candidate SCS's 10 is chosen to provide the Wireless  
15 Location System with sufficient opportunity and ability to measure and mitigate multipath. On any given transmission, any one or more particular antennas at one or more SCS's 10 may receive signals that have been affected to varying degrees by multipath. Therefore, it is advantageous to provide this means within the Wireless Location System to dynamically select a set of antennas which may have received less multipath than other  
20 antennas. The Wireless Location System uses various techniques to mitigate as much multipath as possible from any received signal; however it is frequently prudent to choose a set of antennas that contain the least amount of multipath.

#### Choosing Reference and Cooperating SCS/Antennas

25 In choosing the set of SCS/antennas to use in location processing, the Wireless Location System orders the candidate SCS/antennas using several criteria, including for example: average SNR over the transmission interval used for location processing, the variance in the SNR over the same interval, correlation of the beginning of the received transmission against a pure pre-cursor (i.e. for AMPS, the dotting and Barker code) and/or demodulated  
30 data from the primary SCS/antenna, the time of the on-set of the transmission relative to the on-set reported at the SCS/antenna at which the transmission was demodulated, and the magnitude and rate of change of the SNR from just before the on-set of the

transmission to the on-set of the transmission, as well as other similar parameters. The average SNR is typically determined at each SCS, and for each antenna in the candidate list either over the entire length of the transmission to be used for location processing, or over a shorter interval. The average SNR over the shorter interval can be determined by performing a correlation with the dotting sequence and/or Barker code and/or sync word, depending on the particular air interface protocol, and over a short range of time before, during, and after the timestamp reported by the primary SCS 10. The time range may typically be +/- 200 microseconds centered at the timestamp, for example. The Wireless Location System will generally order the candidate SCS/antennas using the following criteria, each of which may be weighted when combining the criteria to determine the final decision: average SNR for a given SCS/antenna must be greater than a predetermined threshold to be used in location processing; SCS/antennas with higher average SNR are preferred over those with lower average SNR; SCS/antennas with lower SNR variance are preferred to those with higher SNR variance; SCS/antennas with an on-set closer to the on-set reported by the demodulating SCS/antenna are preferred to those with an on-set more distant in time; SCS/antennas with a faster SNR rate of change are preferred to those with a slower rate of change; SCS/antennas with lower incremental weighted GDOP are preferred over those with higher incremental weighted GDOP, where the weighting is based upon estimated path loss from the primary SCS. The weighting applied to each of these preferences may be adjusted by the operator of the Wireless Location System to suit the particular design of each system. The number of different SCS's 10 used in the location processing is maximized up to a predetermined limit; the number of antennas used at each SCS 10 is limited to a predetermined limit; and the total number of SCS/antennas used is limited to max\_number\_antennas\_processed. The SCS/antenna with the highest ranking using the above described process is designated as the reference SCS/antenna for location processing.

#### Best Port Selection Within an SCS 10

Frequently, the SCS/antennas in the candidate list or in the list to use in location processing will include only one or two antennas at a particular SCS 10. In these cases, the Wireless Location System may permit the SCS 10 to choose the "best port" from all or some of the antennas at the particular SCS 10. For example, if the Wireless Location

System chooses to use only one antenna at a first SCS 10, then the first SCS 10 may select the best antenna port from the typical six antenna ports that are connected to that SCS 10, or it may choose the best antenna port from among the two antenna ports of just one sector of the cell site. The best antenna port is chosen by using the same process and comparing  
5 the same parameters as described above for choosing the set of SCS/antennas to use in location processing, except that all of the antennas being considered for best port are all in the same SCS 10. In comparing antennas for best port, the SCS 10 may also optionally divide the received signal into segments, and then measure the SNR separately in each segment of the received signal. Then, the SCS 10 can optionally choose the best antenna  
10 port with highest SNR either by (i) using the antenna port with the most segments with the highest SNR, (ii) averaging the SNR in all segments and using the antenna port with the highest average SNR, or (iii) using the antenna port with the highest SNR in any one segment.

15 Detection and Recovery From Collisions

Because the Wireless Location System will use data from many SCS/antenna ports in location processing, there is a chance that the received signal at one or more particular SCS/antenna ports contains energy that is co-channel interference from another wireless transmitter (i.e. a partial or full collision between two separate wireless transmissions has  
20 occurred). There is also a reasonable probability that the co-channel interference has a much higher SNR than the signal from the target wireless transmitter, and if not detected by the Wireless Location System, the co-channel interference may cause an incorrect choice of best antenna port at an SCS 10, reference SCS/antenna, candidate SCS/antenna, or SCS/antenna to be used in location processing. The co-channel interference may also  
25 cause poor TDOA and FDOA results, leading to a failed or poor location estimate. The probability of collision increases with the density of cell sites in the host wireless communications system, especially in dense suburban or rural environments where the frequencies are re-used often and wireless usage by subscribers is high.

30 Therefore, the Wireless Location System includes means to detect and recover from the types of collisions described above. For example, in the process of selecting a best port, reference SCS/antenna, or candidate SCS/antenna, the Wireless Location System

determines the average SNR of the received signal and the variance of the SNR over the interval of the transmission; when the variance of the SNR is above a predetermined threshold, the Wireless Location System assigns a probability that a collision has occurred. If the signal received at an SCS/antenna has increased or decreased its SNR in a single step, and by an amount greater than a predetermined threshold, the Wireless Location System assigns a probability that a collision has occurred. Further, if the average SNR of the signal received at a remote SCS is greater than the average SNR that would be predicted by a propagation model, given the cell site at which the wireless transmitter initiated its transmission and the known transmit power levels and antenna patterns of the transmitter and receive antennas, the Wireless Location System assigns a probability that a collision has occurred. If the probability that a collision has occurred is above a predetermined threshold, then the Wireless Location System performs the further processing described below to verify whether and to what extent a collision may have impaired the received signal at an SCS/antenna. The advantage of assigning probabilities is to reduce or eliminate extra processing for the majority of transmissions for which collisions have not occurred. It should be noted that the threshold levels, assigned probabilities, and other details of the collision detection and recovery processes described herein are configurable, i.e., selected based on the particular application, environment, system variables, etc., that would affect their selection.

For received transmissions at an SCS/antenna for which the probability of a collision is above the predetermined threshold and before using RF data from a particular antenna port in a reference SCS/antenna determination, best port determination or in location processing, the Wireless Location System preferably verifies that the RF data from each antenna port is from the correct wireless transmitter. This is determined, for example, by demodulating segments of the received signal to verify, for example, that the MIN, MSID, or other identifying information is correct or that the dialed digits or other message characteristics match those received by the SCS/antenna that initially demodulated the transmission. The Wireless Location System may also correlate a short segment of the received signal at an antenna port with the signal received at the primary SCS to verify that the correlation result is above a predetermined threshold. If the Wireless Location System detects that the variance in the SNR over the entire length of the transmission is

above a pre-determined threshold, the Wireless Location System may divide the transmission into segments and test each segment as described herein to determine whether the energy in that segment is primarily from the signal from the wireless transmitter for which location processing has been selected or from an interfering  
5 transmitter.

The Wireless Location System may choose to use the RF data from a particular SCS/antenna in location processing even if the Wireless Location System has detected that a partial collision has occurred at that SCS/antenna. In these cases, the SCS  
10 uses the means described above to identify that portion of the received transmission which represents a signal from the wireless transmitter for which location processing has been selected, and that portion of the received transmission which contains co-channel interference. The Wireless Location System may command the SCS 10 to send or use only selected segments of the received transmission that do not contain the co-channel  
15 interference. When determining the TDOA and FDOA for a baseline using only selected segments from an SCS/antenna, the Wireless Location System uses only the corresponding segments of the transmission as received at the reference SCS/antenna. The Wireless Location System may continue to use all segments for baselines in which no collisions were detected. In many cases, the Wireless Location System is able to complete  
20 location processing and achieve an acceptable location error using only a portion of the transmission. This inventive ability to select the appropriate subset of the received transmission and perform location processing on a segment by segment basis enables the Wireless Location System to successfully complete location processing in cases that might have failed using previous techniques.

25

#### Multiple Pass Location Processing

Certain applications may require a very fast estimate of the general location of a wireless transmitter, followed by a more accurate estimate of the location that can be sent subsequently. This can be valuable, for example, for E9-1-1 systems that handle wireless  
30 calls and must make a call routing decision very quickly, but can wait a little longer for a more exact location to be displayed upon the E9-1-1 call-taker's electronic map terminal.

The Wireless Location System supports these applications with an inventive multiple pass location processing mode.

In many cases, location accuracy is enhanced by using longer segments of the transmission and increasing the processing gain through longer integration intervals. But longer segments of the transmission require longer processing periods in the SCS 10 and TLP 12, as well as longer time periods for transmitting the RF data across the communications interface from the SCS 10 to the TLP 12. Therefore, the Wireless Location System includes means to identify those transmissions that require a fast but rough estimate of the location followed by more complete location processing that produces a better location estimate. The Signal of Interest Table includes a flag for each Signal of Interest that requires a multiple pass location approach. This flag specifies the maximum amount of time permitted by the requesting location application for the first estimate to be sent, as well as the maximum amount of time permitted by the requesting location application for the final location estimate to be sent. The Wireless Location System performs the rough location estimate by selecting a subset of the transmission for which to perform location processing. The Wireless Location System may choose, for example, the segment that was identified at the primary SCS/antenna with the highest average SNR. After the rough location estimate has been determined, using the methods described earlier, but with only a subset of the transmission, the TLP 12 forwards the location estimate to the AP 14, which then forwards the rough estimate to the requesting application with a flag indicating that the estimate is only rough. The Wireless Location System then performs its standard location processing using all of the aforementioned methods, and forwards this location estimate with a flag indicating the final status of this location estimate. The Wireless Location System may perform the rough location estimate and the final location estimate sequentially on the same DSP in a TLP 12, or may perform the location processing in parallel on different DSP's. Parallel processing may be necessary to meet the maximum time requirements of the requesting location applications. The Wireless Location System supports different maximum time requirements from different location applications for the same wireless transmission.

Very Short Baseline TDOA

The Wireless Location System is designed to operate in urban, suburban, and rural areas. In rural areas, when there are not sufficient cell sites available from a single wireless carrier, the Wireless Location System can be deployed with SCS's 10 located at the cell sites of other wireless carriers or at other types of towers, including AM or FM radio station, paging, and two-way wireless towers. In these cases, rather than sharing the existing antennas of the wireless carrier, the Wireless Location System may require the installation of appropriate antennas, filters, and low noise amplifiers to match the frequency band of the wireless transmitters of interest to be located. For example, an AM radio station tower may require the addition of 800 MHz antennas to locate cellular band transmitters. There may be cases, however, where no additional towers of any type are available at reasonable cost and the Wireless Location System must be deployed on just a few towers of the wireless carrier. In these cases, the Wireless Location System supports an antenna mode known as very short baseline TDOA. This antenna mode becomes active when additional antennas are installed on a single cell site tower, whereby the antennas are placed at a distance of less than one wavelength apart. This may require the addition of just one antenna per cell site sector such that the Wireless Location System uses one existing receive antenna in a sector and one additional antenna that has been placed next to the existing receive antenna. Typically, the two antennas in the sector are oriented such that the primary axes, or line of direction, of the main beams are parallel and the spacing between the two antenna elements is known with precision. In addition, the two RF paths from the antenna elements to the receivers in the SCS 10 are calibrated.

In its normal mode, the Wireless Location System determines the TDOA and FDOA for pairs of antenna that are separated by many wavelengths. For a TDOA on a baseline using antennas from two difference cell sites, the pairs of antennas are separated by thousands of wavelengths. For a TDOA on a baseline using antennas at the same cell site, the pairs of antennas are separated by tens of wavelengths. In either case, the TDOA determination effectively results in a hyperbolic line bisecting the baseline and passing through the location of the wireless transmitter. When antennas are separated by multiple wavelengths, the received signal has taken independent paths from the wireless transmitter to each antenna, including experiencing different multipath and Doppler shifts. However, when



two antennas are closer than one wavelength, the two received signals have taken essentially the same path and experienced the same fading, multipath, and Doppler shift. Therefore, the TDOA and FDOA processing of the Wireless Location System typically produces a Doppler shift of zero (or near-zero) hertz, and a time difference on the order of zero to one nanosecond. A time difference that short is equivalent to an unambiguous phase difference between the signals received at the two antennas on the very short baseline. For example, at 834 MHz, the wavelength of an AMPS reverse control channel transmission is about 1.18 feet. A time difference of 0.1 nanoseconds is equivalent to a received phase difference of about 30 degrees. In this case, the TDOA measurement produces a hyperbola that is essentially a straight line, still passing through the location of the wireless transmitter, and in a direction that is rotated 30 degrees from the direction of the parallel lines formed by the two antennas on the very short baseline. When the results of this very short baseline TDOA at the single cell site are combined with a TDOA measurement on a baseline between two cell sites, the Wireless Location System can determine a location estimate using only two cell sites.

#### Bandwidth Monitoring Method For Improving Location Accuracy

AMPS cellular transmitters presently comprise the large majority of the wireless transmitters used in the U.S. and AMPS reverse voice channel transmissions are generally FM signals modulated by both voice and a supervisory audio tone (SAT). The voice modulation is standard FM, and is directly proportional to the speaking voice of the person using the wireless transmitter. In a typical conversation, each person speaks less than 35% of the time, which means that most of the time the reverse voice channel is not being modulated due to voice. With or without voice, the reverse channel is continuously modulated by SAT, which is used by the wireless communications system to monitor channel status. The SAT modulation rate is only about 6 KHz. The voice channels support in-band messages that are used for hand-off control and for other reasons, such as for establishing a 3-way call, for answering a second incoming call while already on a first call, or for responding to an 'audit' message from the wireless communications system. All of these messages, though carried on the voice channel, have characteristics similar to the control channel messages. These messages are transmitted infrequently, and location

systems have ignored these messages and focused on the more prevalent SAT transmissions as the signal of interest.

In view of the above-described difficulties presented by the limited bandwidth of the FM voice and SAT reverse voice channel signals, an object of the present invention is to provide an improved method by which reverse voice channel (RVC) signals may be utilized to locate a wireless transmitter, particularly in an emergency situation. Another object of the invention is to provide a location method that allows the location system to avoid making location estimates using RVC signals in situations in which it is likely that the measurement will not meet prescribed accuracy and reliability requirements. This saves system resources and improves the location system's overall efficiency. The improved method is based upon two techniques. Figure 10A is a flowchart of a first method in accordance with the present invention for measuring location using reverse voice channel signals. The method comprises the following steps:

- (i) It is first assumed that a user with a wireless transmitter wishes to be located, or wishes to have his location updated or improved upon. This may be the case, for example, if the wireless user has dialed "911" and is seeking emergency assistance. It is therefore also assumed that the user is coherent and in communication with a centrally located dispatcher.
- (ii) When the dispatcher desires a location update for a particular wireless transmitter, the dispatcher sends a location update command with the identity of the wireless transmitter to the Wireless Location System over an application interface.
- (iii) The Wireless Location System responds to the dispatcher with a confirmation that the Wireless Location System has queried the wireless communications system and has obtained the voice channel assignment for the wireless transmitter.
- (iv) The dispatcher instructs the wireless user to dial a 9 or more digit number and then the "SEND" button. This sequence may be something like "123456789" or "911911911". Two functions happen to the reverse voice channel when the wireless user dial a sequence of at least 9 digits and then the "SEND" button. First, especially for an AMPS cellular voice channel, the dialing of digits causes the sending of dual tone multi-frequency (DTMF) tones over the voice channel. The

modulation index of DTMF tones is very high and during the sending of each digit in the DTMF sequence will typically push the bandwidth of the transmitted signal beyond +/- 10 KHz. The second function occurs at the pressing of the "SEND" button. Whether or not the wireless user subscribes to 3-way calling or other special features, the wireless transmitter will send a message over the voice using a "blank and burst" mode where the transmitter briefly stops sending the FM voice and SAT, and instead sends a bursty message modulated in the same manner as the control channel (10 Kbits Manchester). If the wireless user dials less than 9 digits, the message will be comprised of approximately 544 bits. If the wireless user dials 9 or more digits, the message is comprised of approximately 987 bits.

(v) After notification by the dispatcher, the Wireless Location System monitors the bandwidth of the transmitted signal in the voice channel. As discussed earlier, when only the SAT is being transmitted, and even if voice and SAT are being transmitted, there may not be sufficient bandwidth in the transmitted signal to calculate a high quality location estimate. Therefore, the Wireless Location System conserves location processing resources and waits until the transmitted signal exceeds a predetermined bandwidth. This may be, for example, set somewhere in the range of 8 KHz to 12 KHz. When the DTMF dialed digits are sent or when the bursty message is sent, the bandwidth would typically exceed the predetermined bandwidth. In fact, if the wireless transmitter does transmit the DTMF tones during dialing, the bandwidth would be expected to exceed the predetermined bandwidth multiple times. This would provide multiple opportunities to perform a location estimate. If the DTMF tones are not sent during dialing, the bursty message is still sent at the time of pressing "SEND", and the bandwidth would typically exceed the predetermined threshold.

(vi) Only when the transmitted bandwidth of the signal exceeds the predetermined bandwidth, the Wireless Location System initiates location processing.

Figure 10B is a flowchart of another method in accordance with the present invention for measuring location using reverse voice channel signals. The method comprises the following steps:

- 5 (i) It is first assumed that a user with a wireless transmitter wishes to be located, or wishes to have their location updated or improved upon. This may be the case, for example, if the wireless user has dialed "911" and is seeking emergency assistance. It is assumed that the user may not wish to dial digits or may not be able to dial any digits in accordance with the previous method.
- (ii) When the dispatcher desires a location update for a particular wireless transmitter user, the dispatcher sends a location update command to the Wireless Location System over an application interface with the identity of the wireless transmitter.
- (iii) The Wireless Location System responds to the dispatcher with a confirmation.
- 10 (iv) The Wireless Location System commands the wireless communications system to make the wireless transmitter transmit by sending an "audit" or similar message to the wireless transmitter. The audit message is a mechanism by which the wireless communications system can obtain a response from the wireless transmitter without requiring an action by the end-user and without causing the wireless transmitter to ring or otherwise alert. The receipt of an audit message causes the wireless transmitter to respond with an "audit response" message on the voice channel.
- 15 (v) After notification by the dispatcher, the Wireless Location System monitors the bandwidth of the transmitted signal in the voice channel. As discussed earlier, when only the SAT is being transmitted, and even if voice and SAT are being transmitted, there may not be sufficient bandwidth in the transmitted signal to calculate a high quality location estimate. Therefore, the radio location conserves location processing resources and waits until the transmitted signal exceeds a predetermined bandwidth. This may be, for example, set somewhere in the range of 8 KHz to 12 KHz. When the audit response message is sent, the bandwidth would typically exceed the predetermined bandwidth.
- 20 (vi) Only when the transmitted bandwidth of the signal exceeds the predetermined bandwidth, the Wireless Location System initiates location processing.
- 25

30 Estimate Combination Method For Improving Location Accuracy

The accuracy of the location estimate provided by the Wireless Location System may be improved by combining multiple statistically-independent location estimates made while

the wireless transmitter is maintaining its position. Even when a wireless transmitter is perfectly stationary, the physical and RF environment around a wireless transmitter is constantly changing. For example, vehicles may change their position or another wireless transmitter which had caused a collision during one location estimate may have stopped transmitting or changed its position so as to no longer collide during subsequent location estimates. The location estimate provided by the Wireless Location System will therefore change for each transmission, even if consecutive transmissions are made within a very short period of time, and each location estimate is statistically independent of the other estimates, particularly with respect to the errors caused by the changing environment.

When several consecutive statistically independent location estimates are made for a wireless transmitter that has not changed its position, the location estimates will tend to cluster about the true position. The Wireless Location System combines the location estimates using a weighted average or other similar mathematical construct to determine the improved estimate. The use of a weighted average is aided by the assignment of a quality factor to each independent location estimate. This quality factor may be based upon, for example, the correlation values, confidence interval, or other similar measurements derived from the location processing for each independent estimate. The Wireless Location System optionally uses several methods to obtain multiple independent transmissions from the wireless transmitter, including (i) using its interface to the wireless communications system for the Make Transmit command; (ii) using multiple consecutive bursts from a time slot based air interface protocol, such as TDMA or GSM; or (iii) dividing a voice channel transmission into multiple segments over a period of time and performing location processing independently for each segment. As the Wireless Location System increases the number of independent location estimates being combined into the final location estimate, it monitors a statistic indicating the quality of the cluster. If the statistic is below a prescribed threshold value, then the Wireless Location System assumes that the wireless transmitter is maintaining its position. If the statistic rises above the prescribed threshold value, the Wireless Location System assume that the wireless transmitter is not maintaining its position and therefore ceases to perform additional location estimates. The statistic indicating the quality of the cluster may be, for example, a standard deviation calculation or a root mean square (RMS) calculation for the individual

location estimates being combined together and with respect to the dynamically calculated combined location estimate. When reporting a location record to a requesting application, the Wireless Location System indicates, using a field in the location record, the number of independent location estimate combined together to produce the reported location  
5 estimate.

Another exemplary process for obtaining and combining multiple location estimates will now be explained with reference to Figures 11A-11D. Figures 11A, 11B and 11C schematically depict the well-known "origination", "page response," and "audit" sequences  
10 of a wireless communications system. As shown in Figure 11A, the origination sequence (initiated by the wireless phone to make a call) may require two transmissions from the wireless transmitter, an "originate" signal and an "order confirmation" signal. The order confirmation signal is sent in response to a voice channel assignment from the wireless communications system (e.g., MSC). Similarly, as shown in Figure 11B, a page sequence  
15 may involve two transmissions from the wireless transmitter. The page sequence is initiated by the wireless communications system, e.g., when the wireless transmitter is called by another phone. After being paged, the wireless transmitter transmits a page response; and then, after being assigned a voice channel, the wireless transmitter transmits an order confirmation signal. The audit process, in contrast, elicits a single reverse  
20 transmission, an audit response signal. An audit and audit response sequence has the benefit of not ringing the wireless transmitter which is responding.

The manner in which these sequences may be used to locate a phone with improved accuracy will now be explained. According to the present invention, for example, a stolen  
25 phone, or a phone with a stolen serial number, is repeatedly pinged with an audit signal, which forces it to respond with multiple audit responses, thus permitting the phone to be located with greater accuracy. To use the audit sequence, however, the Wireless Location System sends the appropriate commands using its interface to the wireless communications system, which sends the audit message to the wireless transmitter. The  
30 Wireless Location System can also force a call termination (hang up) and then call the wireless transmitter back using the standard ANI code. The call can be terminated either by verbally instructing the mobile user to disconnect the call, by disconnecting the call at

the landline end of the call, or by sending an artificial over-the-air disconnect message to the base station. This over-the-air disconnect message simulates the pressing of the "END" button on a mobile unit. The call-back invokes the above-described paging sequence and forces the phone to initiate two transmissions that can be utilized to make location estimates.

Referring now to Figure 11D, the inventive high accuracy location method will now be summarized. First, an initial location estimate is made. Next, the above-described audit or "hang up and call back" process is employed to elicit a responsive transmission from the mobile unit, and then a second location estimate is made. Whether the audit or "hang up and call back" process is used will depend on whether the wireless communications system and wireless transmitter have both implemented the audit functionality. Steps second and third steps are repeated to obtain however many independent location estimates are deemed to be necessary or desirable, and ultimately the multiple statistically-independent location estimates are combined in an average, weighted average, or similar mathematical construct to obtain an improved estimate. The use of a weighted average is aided by the assignment of a quality factor to each independent location estimate. This quality factor may be based upon a correlation percentage, confidence interval, or other similar measurements derived from the location calculation process.

#### Bandwidth Synthesis Method For Improving Location Accuracy

The Wireless Location System is further capable of improving the accuracy of location estimates for wireless transmitters whose bandwidth is relatively narrow using a technique of artificial bandwidth synthesis. This technique can be applied, for example, to those transmitters that use the AMPS, NAMPS, TDMA, and GSM air interface protocols and for which there are a large number of individual RF channels available for use by the wireless transmitter. For exemplary purposes, the following description shall refer to AMPS-specific details; however, the description can be easily altered to apply to other protocols. This method relies on the principle that each wireless transmitter is operative to transmit only narrowband signals at frequencies spanning a predefined wide band of frequencies that is wider than the bandwidth of the individual narrowband signals transmitted by the wireless transmitter. This method also relies on the aforementioned interface between the

Wireless Location System and the wireless communications system over which the WLS can command the wireless communications system to make a wireless transmitter handoff or switch to another frequency or RF channel. By issuing a series of commands, the Wireless Location System can force the wireless transmitter to switch sequentially and in a controlled manner to a series of RF channels, allowing the WLS effectively to synthesize a wider band received signal from the series of narrowband transmitted signals for the purpose of location processing.

In a presently preferred embodiment of the invention, the bandwidth synthesis means includes means for determining a wideband phase versus frequency characteristic of the transmissions from the wireless transmitter. For example, the narrowband signals typically have a bandwidth of approximately 20 KHz and the predefined wide band of frequencies spans approximately 12.5 MHz, which in this example, is the spectrum allocated to each cellular carrier by the FCC. With bandwidth synthesis, the resolution of the TDOA measurements can be increased to about  $1/12.5$  MHz; i.e., the available time resolution is the reciprocal of the effective bandwidth.

A wireless transmitter, a calibration transmitter (if used), SCS's 10A, 10B and 10C, and a TLP 12 are shown in Figure 12A. The location of the calibration transmitter and all three SCS's are accurately known *a priori*. Signals, represented by dashed arrows in Figure 12A, are transmitted by the wireless transmitter and calibration transmitter, and received at SCS's 10A, 10B and 10C, and processed using techniques previously described. During the location processing, RF data from one SCS (e.g. 10B) is cross-correlated (in the time or frequency domain) with the data stream from another SCS (e.g. 10C) separately for each transmitter and for each pair of SCS's 10 to generate TDOA estimates  $TDOA_{23}$  and  $TDOA_{13}$ . An intermediate output of the location processing is a set of coefficients representing the complex cross-power as a function of frequency (e.g.,  $R_{23}$ ).

For example, if  $X(f)$  is the Fourier transform of the signal  $x(t)$  received at a first site and  $Y(f)$  is the Fourier transform of the signal  $y(t)$  received at a second site, then the complex cross-power  $R(f)=X(f)Y^*(f)$ , where  $Y^*$  is the complex conjugate of  $Y$ . The phase angle of  $R(f)$  at any frequency  $f$  equals the phase of  $X(f)$  minus the phase of  $Y(f)$ . The phase angle



of  $R(f)$  may be called the fringe phase. In the absence of noise, interference, and other errors, the fringe phase is a perfectly linear function of frequency within a (contiguous) frequency band observed; and slope of the line is minus the interferometric group delay, or TDOA; the intercept of the line at the band center frequency, equal to the average value of the phase of  $R(f)$ , is called "the" fringe phase of the observation when reference is being made to the whole band. Within a band, the fringe phase may be considered to be a function of frequency.

The coefficients obtained for the calibration transmitter are combined with those obtained for the wireless transmitter and the combinations are analyzed to obtain calibrated TDOA measurements  $TDOA_{23}$  and  $TDOA_{13}$ , respectively. In the calibration process, the fringe phase of the calibration transmitter is subtracted from the fringe phase of the wireless transmitter in order to cancel systematic errors that are common to both. Since each original fringe phase is itself the difference between the phases of signals received at two SCS's 10, the calibration process is often called *double-differencing* and the calibrated result is said to be *doubly-differenced*. TDOA estimate  $T_{ij}$  is a maximum-likelihood estimate of the time difference of arrival (TDOA), between sites  $i$  and  $j$ , of the signal transmitted by the wireless transmitter, calibrated and also corrected for multipath propagation effects on the signals. TDOA estimates from different pairs of cell sites are combined to derive the location estimate. It is well known that more accurate TDOA estimates can be obtained by observing a wider bandwidth. It is generally not possible to increase the "instantaneous" bandwidth of the signal transmitted by a wireless transmitter, but it is possible to command a wireless transmitter to switch from one frequency channel to another so that, in a short time, a wide bandwidth can be observed.

In a typical non-wireline cellular system, for example, channels 313-333 are control channels and the remaining 395 channels are voice channels. The center frequency of a wireless transmitter transmitting on voice RF channel number 1 (RVC 1) is 826.030 MHz and the center-to-center frequency spacing of successive channels of 0.030 MHz. The number of voice channels assigned to each cell of a typical seven-cell frequency-reuse block is about 57 (i.e., 395 divided by 7) and these channels are distributed throughout the 395-channel range, spaced every 7 channels. Note then that each cell site used in an

AMPS system has channels that span the entire 12.5 MHz band allocated by the FCC. If, for example, we designate cells of each frequency set in a re-use pattern as cells "A" through "G", the channel numbers assigned to the "A" cell(s) might be 1, 8, 15, 22, ..., 309; the numbers of the channels assigned to the "B" cells are determined by adding 1 to the "A" channel numbers; and so on through G.

The method begins when the wireless transmitter has been assigned to a voice RF channel, and the Wireless Location System has triggered location processing for the transmissions from the wireless transmitter. As part of the location processing, the TDOA estimates TDOA<sub>13</sub> and TDOA<sub>23</sub> combined may have, for example, a standard deviation error of 0.5 microsecond. The method combining measurements from different RF channels exploits the relation between TDOA, fringe phase, and radio frequency. Denote the "true" value of the group delay or TDOA, i.e., the value that would be observed in the absence of noise, multipath, and any instrumental error, by  $\tau$ ; similarly, denote the true value of fringe phase by  $\phi$ ; and denote the radio frequency by  $f$ . The fringe phase  $\phi$  is related to  $\tau$  and  $f$  by:

$$\phi = -f\tau + n \quad (\text{Eq. 1})$$

where  $\phi$  is measured in cycles,  $f$  in Hz and  $\tau$  in seconds; and  $n$  is an integer representing the intrinsic integer-cycle ambiguity of a doubly-differenced phase measurement. The value of  $n$  is unknown *a priori* but is the same for observations at contiguous frequencies, i.e., within any one frequency channel. The value of  $n$  is generally different for observations at separated frequencies.  $\tau$  can be estimated from observations in a single frequency channel is, in effect, by fitting a straight line to the fringe phase observed as a function of frequency within the channel. The slope of the best-fitting line equals minus the desired estimate of  $\tau$ . In the single-channel case,  $n$  is constant and so Eq. 1 can be differentiated to obtain:

$$d\phi/df = -\tau \quad (\text{Eq. 2}).$$

Independent estimates of  $\tau$  are obtainable by straight-line fitting to the observations of  $\phi$  vs.  $f$  separately for each channel, but when two separate (non-contiguous) frequency channels are observed, a single straight line will not generally fit the observations of  $\phi$  vs.  $f$  from both channels because, in general, the integer  $n$  has different values for the two channels. However, under certain conditions, it is possible to determine and remove the difference between these two integer values and then to fit a single straight line to the entire set of phase data spanning both channels. The slope of this straight line will be much better determined because it is based on a wider range of frequencies. Under certain conditions, the uncertainty of the slope estimate is inversely proportional to the frequency span.

In this example, suppose that the wireless transmitter has been assigned to voice RF channel 1. The radio frequency difference between channels 1 and 416 is so great that initially the difference between the integers  $n_1$  and  $n_{416}$  corresponding to these channels cannot be determined. However, from the observations in either or both channels taken separately, an initial TDOA estimate  $\tau_0$  can be derived. Now the Wireless Location System commands the wireless communications system to make the wireless transmitter to switch from channel 1 to channel 8. The wireless transmitter's signal is received in channel 8 and processed to update or refine the estimate  $\tau_0$ . From  $\tau_0$ , the "theoretical" fringe-phase  $\phi_0$  as a function of frequency can be computed, equal to  $(-f\tau_0)$ . The difference between the actually observed phase  $\phi$  and the theoretical function  $\phi_0$  can be computed, where the actually observed phase equals the true phase within a very small fraction, typically 1/50th, of a cycle:

$$\phi - \phi_0 = -f(\tau - \tau_0) + n_1 \text{ or } n_8, \text{ depending on the channel} \quad (\text{Eq. 3})$$

or

$$\Delta\phi = -\Delta f\tau - n_1 \text{ or } n_8, \text{ depending on the channel} \quad (\text{Eq. 4})$$

where  $\Delta\phi \equiv \phi - \phi_0$  and  $\Delta\tau \equiv \tau - \tau_0$ . Equation (4) is graphed in Figure 12B, depicting the difference,  $\Delta\phi$ , between the observed fringe phase  $\phi$  and the value  $\phi_0$  computed from the initial TDOA estimate  $\tau_0$ , versus frequency  $f$  for channels 1 and 8.

For the 20 KHz-wide band of frequencies corresponding to channel 1, a graph of  $\Delta\phi$  vs.  $f$  is typically a horizontal straight line. For the 20 KHz-wide band of frequencies corresponding to channel 8, the graph of  $\Delta\phi$  vs.  $f$  is also horizontal straight line. The slopes of these line segments are generally nearly zero because the quantity  $(f\Delta\tau)$  usually does not vary by a significant fraction of a cycle within 20 KHz, because  $\Delta\tau$  is minus the error of the estimate  $\tau_0$ . The magnitude of this error typically will not exceed 1.5 microseconds (3 times the standard deviation of 0.5 microseconds in this example), and the product of 1.5 microseconds and 20 KHz is under 4% of a cycle. In Figure 12B, the graph of  $\Delta\phi$  for channel 1 is displaced vertically from the graph of  $\Delta\phi$  for channel 8 by a relatively large amount because the difference between  $n_1$  and  $n_8$  can be arbitrarily large. This vertical displacement, or difference between the average values of  $\Delta\phi$  for channels 1 and 8, will (with extremely high probability) be within  $\pm 0.3$  cycle of the true value of the difference,  $n_1$  and  $n_8$ , because the product of the maximum likely magnitude of  $\Delta\tau$  (1.5 microseconds) and the spacing of channels 1 and 8 (210 KHz) is 0.315 cycle. In other words, the difference  $n_1 - n_8$  is equal to the difference between the average values of  $\Delta\phi$  for channels 1 and 8, rounded to the nearest integer. After the integer difference  $n_1 - n_8$  is determined by this rounding procedure, the integer  $\Delta\phi$  is added for channel 8 or subtracted from  $\Delta\phi$  for channel 1: The difference between the average values of  $\Delta\phi$  for channels 1 and 8 is generally equal to the error in the initial TDOA estimate,  $\tau_0$ , times 210 KHz. The difference between the average values of  $\Delta\phi$  for channels 1 and 8 is divided by 210 KHz and the result is added to  $\tau_0$  to obtain an estimate of  $\tau$ , the true value of the TDOA; this new estimate can be significantly more accurate than  $\tau_0$ .

This frequency-stepping and TDOA-refining method can be extended to more widely spaced channels to obtain yet more accurate results. If  $\tau_1$  is used to represent the refined result obtained from channels 1 and 8,  $\tau_0$  can be replaced by  $\tau_1$  in the just-described method; and the Wireless Location System can command the wireless communications system to make the wireless transmitter switch, e.g., from channel 8 to channel 36; then  $\tau_1$  can be used to determine the integer difference  $n_8 - n_{36}$  and a TDOA estimate can be obtained based on the 1.05 MHz frequency span between channels 1 and 36. The

estimated can be labeled  $\tau_2$ ; and the wireless transmitter switched, e.g., from channel 36 to 112, and so on. In principle, the full range of frequencies allocated to the cellular carrier can be spanned. The channel numbers (1, 8, 36, 112) used in this example are, of course, arbitrary. The general principle is that an estimate of the TDOA based on a small  
5 frequency span (starting with a single channel) is used to resolve the integer ambiguity of the fringe phase difference between more widely separated frequencies. The latter frequency separation should not be too large; it is limited by the uncertainty of the prior estimate of TDOA. In general, the worst-case error in the prior estimate multiplied by the frequency difference may not exceed 0.5 cycle.

10

If the very smallest (e.g., 210 KHz) frequency gap between the most closely spaced channels allocated to a particular cell cannot be bridged because the worst-case uncertainty of the single-channel TDOA estimate exceeds 2.38 microseconds (equal to 0.5 cycle divided by 0.210 MHz), the Wireless Location System commands the wireless  
15 communications system to force the wireless transmitter hand-off from one cell site to another (e.g. from one frequency group to another), such that the frequency step is smaller. There is a possibility of misidentifying the integer difference between the phase differences ( $\Delta\phi$ 's) for two channels, e.g., because the wireless transmitter moved during the handoff from one channel to the other. Therefore, as a check, the Wireless Location  
20 System may reverse each handoff (e.g., after switching from channel 1 to channel 8, switch from channel 8 back to channel 1) and confirm that the integer-cycle difference determined has precisely the same magnitude and the opposite sign as for the "forward" hand-off. A significantly nonzero velocity estimate from the single-channel FDOA observations can be used to extrapolate across the time interval involved in a channel  
25 change. Ordinarily this time interval can be held to a small fraction of 1 second. The FDOA estimation error multiplied by the time interval between channels must be small in comparison with 0.5 cycle. The Wireless Location System preferably employs a variety of redundancies and checks against integer-misidentification.

### 30 Directed Retry for 911

Another inventive aspect of the Wireless Location System relates to a "directed retry" method for use in connection with a dual-mode wireless communications

system supporting at least a first modulation method and a second modulation method. In such a situation, the first and second modulation methods are assumed to be used on different RF channels (i.e. channels for the wireless communications system supporting a WLS and the PCS system, respectively). It is also assumed that  
5 the wireless transmitter to be located is capable of supporting both modulation methods, i.e. is capable of dialing "911" on the wireless communications system having Wireless Location System support.

For example, the directed retry method could be used in a system in which there are  
10 an insufficient number of base stations to support a Wireless Location System, but which is operating in a region served by a Wireless Location System associated with another wireless communications system. The "first" wireless communications system could be a cellular telephone system and the "second" wireless  
15 communications system could be a PCS system operating within the same territory as the first system. According to the invention, when the mobile transmitter is currently using the second (PCS) modulation method and attempts to originate a call to 911, the mobile transmitter is caused to switch automatically to the first  
20 modulation method, and then to originate the call to 911 using the first modulation method on one of the set of RF channels prescribed for use by the first wireless communications system. In this manner, location services can be provided to customers of a PCS or like system that does is not served by its own Wireless Location System.

#### Conclusion

25 The true scope the present invention is not limited to the presently preferred embodiments disclosed herein. For example, the foregoing disclosure of a presently preferred embodiment of a Wireless Location System uses explanatory terms, such as Signal Collection System (SCS), TDOA Location Processor (TLP), Applications Processor (AP), and the like, which should not be construed so as to limit the scope of protection of the  
30 following claims, or to otherwise imply that the inventive aspects of the Wireless Location System are limited to the particular methods and apparatus disclosed. Moreover, as will be understood by those skilled in the art, many of the inventive aspects disclosed herein may

be applied in location systems that are not based on TDOA techniques. For example, the processes by which the Wireless Location System uses the Tasking List, etc. can be applied to non-TDOA systems. In such non-TDOA systems, the TLP's described above would not be required to perform TDOA calculations. Similarly, the invention is not  
5 limited to systems employing SCS's constructed as described above, nor to systems employing AP's meeting all of the particulars described above. The SCS's, TLP's and AP's are, in essence, programmable data collection and processing devices that could take a variety of forms without departing from the inventive concepts disclosed herein. Given the rapidly declining cost of digital signal processing and other processing functions, it is  
10 easily possible, for example, to transfer the processing for a particular function from one of the functional elements (such as the TLP) described herein to another functional element (such as the SCS or AP) without changing the inventive operation of the system. In many cases, the place of implementation (i.e. the functional element) described herein is merely a designer's preference and not a hard requirement. Accordingly, except as they  
15 may be expressly so limited, the scope of protection of the following claims is not intended to be limited to the specific embodiments described above.

**CLAIMS**

What is claimed is:

1. A signal collection system (SCS), comprising an antenna, a wideband receiver module for multiple reverse control channels (RCC's), a multiport memory, a digital drop receiver  
5 (DDR), a communications bus, and an address generator.
2. An SCS as recited in claim 1, further comprising a local oscillator (LO) for use by the receiver module to select particular RF channels.
- 10 3. An SCS as recited in claim 1, further comprising a wideband digital receiver for reverse voice channels (RVC's).
4. An SCS as recited in claim 1, further comprising means for performing wideband  
15 energy detection for energy in any RF channel.
5. An SCS as recited in claim 4, wherein the SCS measures the presence of signals, and forms a spectral map of the reverse channel spectrum.
6. An SCS as recited in claim 5, wherein the spectral map is sent to a TDOA location  
20 processor (TLP) for use in determining a signal of interest (SOI) and requesting RF data from the DDR.
7. An SCS as recited in claim 1, further comprising an interference filter and RF  
25 preamplifier connected to the wideband receiver module.
8. An SCS as recited in claim 1, further comprising demodulation and normalization  
processors.
9. An SCS as recited in claim 8, wherein the demodulation processor extracts identifying  
30 information about received signals.
10. An SCS as recited in claim 9, further comprising a wideband energy detector.



11. An SCS as recited in claim 10, wherein the SCS comprises a DSP that reduces demodulator bits to 150 or less and identifies an MIN, ESN, and dialed digits in the demodulated signal.
- 5
12. An SCS as recited in claim 11, wherein the SCS comprises a DSP that reduces RF data bits per sample to that required by the TLP.
13. An SCS as recited in claim 12, wherein the number of bits per sample is software  
10 selectable.
14. An SCS as recited in claim 13, wherein the received RCC transmission is divided into segments of 10 ms for processing and forwarding to the TLP.
- 15
15. An SCS as recited in claim 1, further comprising a wideband energy detection means, demodulation and normalization processors tied, and a communications processor providing a communications link.
16. An SCS as recited in claim 15, wherein the communications processor queues,  
20 prioritizes, and transmits traffic, including energy data, demodulation data, and RF data.
17. An SCS as recited in claim 16, wherein the communications processor compands signals, representing detected energy values within a predetermined dynamic range.
- 25
18. An SCS as recited in claim 17, wherein the predetermined dynamic range is represented by 16 levels, using 4 bits; and bits are assigned to optimize the communications link bandwidth.
19. An SCS as recited in claim 18, wherein the values for companding are automatically  
30 adjustable by the communications processor.

20. An SCS as recited in claim 1, wherein the multiport memory is readable at one rate and writeable at a second rate.
21. An SCS as recited in claim 20, wherein the first rate is about 2.5 MHz and the second  
5 rate is about 10 MHz.
22. An SCS as recited in claim 1, wherein the address generator of each SCS has a known relationship to the address generator of each other SCS in the Wireless Location System (WLS).  
10
23. An SCS as recited in claim 22, wherein the known relationship is represented by the memory address currently pointed to by the address generator.
24. An SCS as recited in claim 23, wherein the known relationship is maintained by  
15 synchronizing the address generator to a periodic synchronization pulse.
25. An SCS as recited in claim 24, wherein the periodic synchronization pulse is derived from an external transmission.
- 20 26. An SCS as recited in claim 25, wherein the external transmission is a GPS signal.
27. An SCS as recited in claim 1, wherein the SCS is employed in a Wireless Location System (WLS) that estimates the location of an unknown transmitter, using a first transmission, at least three SCSs, and a TDOA location processor (TLP), wherein the SCS  
25 receives an RF transmission and converts the same into a digital signal at high resolution and stores it into memory; the TLP determines the resolution required per sample and recursively requests samples from the SCS at low or high resolution; the SCS recursively extracts samples and normalizes them to lower resolution and forwards them to the TLP; and the TLP makes the location calculation.  
30
28. An SCS as recited in claim 27, wherein the high resolution is at least 12 bits per sample, and the low resolution is fewer than 12 bits per sample.

29. An SCS as recited in claim 1, wherein the normalizing process uses a common DSP for decimation and digital filtering.
- 5 30. A method for optimizing a communications link, comprising: receiving a signal at a signal collection system (SCS); storing the signal as a plurality of digital samples; determining the fewest number of bits to produce an acceptable location estimate; forwarding the fewest number of bits to a TDOA location processor (TLP) and estimating location; and determining whether additional bits are necessary and forwarding additional  
10 bits to the TLP.
31. A method as recited in claim 30, wherein the number of bits per sample forwarded is automatically determined by measuring the signal power level, and stripping bits that are not required to adequately represent the sample.  
15
32. A method as recited in claim 30, wherein the number of bits per sample is automatically determined separately for each segment of the signal examined.
33. A method as recited in claim 32, wherein the automatic determination is performed in  
20 part by using an FFT on each segment of the signal examined.
34. A method for optimizing a communications link, comprising: receiving a signal at a signal collection system (SCS); storing the signal as a plurality of digital samples each with a prescribed length; determining a shortest length of signal required for an acceptable  
25 location estimate; forwarding the shortest length to a TDOA location processor (TLP) and estimating location; and determining whether additional length is required and, if so, forwarding additional length from the SCS to the TLP.
35. A method as recited in claim 34, wherein the shortest length is less than the entire  
30 length of the transmission.
36. A signal collection system for use in a Wireless Location System, comprising:

- one or more antennas;  
at least one wideband digital receiver operatively coupled to said antenna(s), whereby  
multiple reverse control channel signals are receivable;  
a multiport memory operatively coupled to said wideband digital receiver(s) for  
5 temporarily storing digital samples of received signals;  
a digital drop receiver operatively coupled to the multiport memory for selecting data  
corresponding to a single channel of the wideband digital receiver(s);  
a communications bus providing data paths between said wideband digital receiver(s),  
memory, and digital drop receiver; and  
10 an address generator for controlling access to the multiport memory by the wideband  
digital receiver(s) and by the digital drop receiver.
37. A signal collection system as recited in claim 36, further comprising a common local  
oscillator (LO) operatively coupled to said wideband digital receiver(s) for selectively  
15 generating LO signals of prescribed frequencies for use by said receiver(s) to selectively  
receive a particular channel from the among the multiple channels receivable by said  
receiver(s).
38. A signal collection system as recited in claim 36, further comprising at least one  
20 wideband digital receiver capable of receiving multiple reverse voice channel signals.
39. A signal collection system as recited in claim 36, further comprising a common  
wideband energy detection processor operatively coupled to said wideband digital  
receiver(s) for measuring and reporting the presence of energy, if any, in the channels  
25 receivable by the receiver(s).
40. A signal collection system as recited in claim 36, further comprising an interference  
filter operatively coupled to said antenna(s); and an RF preamplifier and splitter unit  
operatively coupled between each said interference filter and each said wideband digital  
30 receiver.

41. A signal collection system as recited in claim 36, further comprising demodulation and normalization processors operatively coupled to said digital drop receiver.
42. A signal collection system as recited in claim 41, wherein said demodulation processor  
5 comprises means for extracting identifying information about the received signals.
43. A signal collection system as recited in claim 42, further comprising a wideband energy detection processor operatively coupled to said wideband digital receiver(s) for measuring and reporting the presence of energy, if any, in the channels receivable by the  
10 receiver(s); and wherein said wideband energy detection unit and said demodulation and normalization processors comprise digital signal processors (DSP's), said DSP's providing means to detect energy in a particular band, demodulate selected signals, and extract signals of interest for forwarding to a TDOA location processor.
44. A signal collection system as recited in claim 39, wherein said wideband energy  
15 detection unit determines the presence of a transmitted signal in the control channels monitored by the SCS, wherein the wideband energy detection is performed digitally by forming a spectral map of the RCC spectrum, said map being used in part to determine when to demodulate signals within selected RCC's.
- 20 45. A signal collection system as recited in claim 44, wherein the spectral map is forwarded to a TDOA location processor, and when the TDOA location processor has determined that a signal of interest is present it requests RF data for the appropriate channel and time period from the SCS, and wherein the digital drop receiver accesses said  
25 memory and extracts the requested RF data.
46. A signal collection system as recited in claim 42, wherein the demodulation and normalization processors comprise a DSP that performs the following operations on RF  
30 data output from the digital drop receiver: demodulation of signals on selected RCC's, and reduction in the number of sampled bits to provide a message of less than about 150 bits and containing a mobile transmitter's MIN, ESN, message type, dialed digits, and channel number.

47. A signal collection system as recited in claim 42, wherein the demodulation and normalization processors comprise a DSP that performs the following operation on RF data output from the digital drop receiver: reduction of the number of bits per sample from a resolution of the receiver to a resolution required by a TDOA location processor (TLP).
48. A signal collection system as recited in claim 47, where the number of bits per sample output by the demodulation and normalization processor is software selectable on a sample by sample basis.
49. A signal collection system as recited in claim 47, wherein a received reverse control channel or reverse voice channel transmission of varying length is converted into multiple segments of about 10 ms each for processing and forwarding to the TLP.
50. A signal collection system as recited in claim 36, further comprising:  
a wideband energy detection processor operatively coupled to said wideband digital receiver(s) for measuring and reporting the presence of energy in the channels receivable by the receiver(s);  
demodulation and normalization processors operatively coupled to said common digital drop receiver; and  
a communications processor operatively coupled to the wideband energy detection processor and the demodulation and normalization processor and providing a communications link.
51. A signal collection system as recited in claim 50, wherein the communications processor queues, prioritizes, and transmits traffic from the SCS to a TDOA location processor, said traffic including channel energy data, demodulated messages for selected RCCs, and RF data from the normalization processing.
52. A signal collection system as recited in claim 36, wherein said multiport memory is readable at a first maximum rate and writeable at a second maximum rate, wherein said first maximum rate is greater than said second maximum rate.

53. A signal collection system as recited in claim 52, wherein said memory can be written to at a rate of 2.5 MHz and read from at a rate of 10 MHz.
- 5 54. A signal collection system as recited in claim 50, wherein said communications processor includes means for companding signals forwarded to a TLP, whereby the number of bits employed to represent values within a predetermined dynamic range is reduced.
- 10 55. A signal collection system as recited in claim 54, wherein said predetermined dynamic range is quantized into 16 levels that are encoded into 4 bits, and said 4 bits are assigned to optimize the performance of the system by maximizing the use of the available bandwidth on the communications link.
- 15 56. A signal collection system as recited in claim 36, wherein the values for the companding are automatically adjustable by the communications processor.
57. A Wireless Location System which is operative to estimate the location of a first mobile transmitter at an unknown location using at least a first RF transmission from said transmitter, comprising three signal collection systems (SCSs) and a TDOA location processor (TLP) operatively coupled to said SCSs; wherein said SCSs and TLP are operative to perform the following functions:
- 20 at each SCS, receiving the first RF transmission and converting said RF transmission into a digital signal composed of multiple high resolution digital samples, and storing the high resolution digital samples into a temporary memory;
- 25 within the TLP, determining the resolution per digital sample required to produce a location estimate of the first mobile transmitter, and recursively requesting that the digital samples be sent from the SCS's to the TLP at either a low resolution or a high resolution per digital sample;
- 30 at each SCS, recursively extracting the digital samples from temporary memory and normalizing the digital samples down to a lower resolution, and forwarding the digital samples to the TLP; and

within the TLP, making location calculations to estimate the location of the first mobile transmitter.

58. A Wireless Location System as recited in claim 57, wherein the high resolution samples comprise at least 12 bits per sample, and the low resolution samples comprise fewer than 12 bits per sample.
59. A Wireless Location System as recited in claim 57, wherein the normalizing process is performed in a digital signal processor capable of digital filtering and decimation to accept high resolution digital samples and output low resolution digital samples.
60. A method for optimizing the use of communications links in a Wireless Location System, the method comprising the steps of:
- receiving a signal from a mobile transmitter at a signal collection system;
  - storing the signals digitally, as a plurality of digital samples, into temporary memory in the signal collection system;
  - determining the fewest number of bits per digital sample required to produce an acceptable location estimate;
  - forwarding the fewest number of bits per sample from said signal collection system to the TDOA location processor and estimating the location of the mobile transmitter on the basis of said bits received from said SCS as well as bits received from other signal collection systems; and
  - determining whether additional bits per sample are necessary to achieve a desired level of accuracy of the location estimate, and, if so, sending additional bits per sample over the communications link from the signal collection system to the TDOA location processor.
61. A method for optimizing the use of communications links in a Wireless Location System, the method comprising the steps of:
- receiving a signal from a mobile transmitter at a signal collection system;



storing the signals digitally, as a plurality of digital samples defining a plurality of signal segments each having a prescribed length, into temporary memory in the signal collection system;

5 determining the shortest length of signal, or fewest number of segments, required to produce an acceptable location estimate;

forwarding the shortest length of signal, or fewest number of segments, from said signal collection system to the TDOA location processor and estimating the location of the mobile transmitter; and

10 determining whether additional samples or more segments are necessary to achieve a desired level of accuracy of the location estimate, and, if so, sending additional samples over the communications link from the signal collection system to the TDOA location processor.

62. A signal collection system (SCS) for use in a Wireless Location System that

15 determines the geographic location of mobile transmitters by receiving and processing transmissions emitted by said mobile transmitters, wherein said Wireless Location System includes at least one TDOA location processor (TLP) operatively coupled to said SCS, said SCS comprising:

20 a wideband reverse control channel (RCC) receiver;

a reverse voice channel (RVC) receiver;

a wideband energy detection unit operatively coupled to said RCC and RVC receivers;

a memory operatively coupled to said RCC and RVC receivers to temporarily store digital samples of received RCC and RVC signals; and

25 a communications processor operatively coupled to said wideband energy detection unit, wherein said communications processor provides a communications link to at least one TLP.

63. A signal collection system as recited in claim 62, further comprising a digital drop receiver operatively coupled to said memory, and demodulation and normalization

30 processors operatively coupled to said digital drop receiver.

64. A signal collection system as recited in claim 62, wherein said memory comprises a dual port memory that can be read from at a higher rate than it is written to.
65. A signal collection system as recited in claim 64, wherein said memory can be written  
5 to at a rate of 2.5 MHz and read from at a rate of 10 MHz.
66. A signal collection system as recited in claim 62, wherein said communications  
processor includes means for companding signals forwarded to the TLP, whereby the  
number of bits employed to represent values within a predetermined dynamic range is  
10 reduced.
67. A signal collection system as recited in claim 66, wherein said predetermined dynamic  
range is quantized into 16 levels that are encoded into 4 bits, and said 4 bits are assigned to  
optimize the performance of the system by maximizing the use of the available bandwidth.  
15
68. A signal collection system as recited in claim 62, wherein the values for the  
companding are automatically adjusted.
69. A signal collection system as recited in claim 62, wherein said system is programmed  
20 to optimize the use of communications links by carrying out the steps of:  
receiving a signal from a mobile transmitter at a signal collection system;  
storing the signals digitally, as a plurality of digital samples, into temporary memory in  
the signal collection system;  
determining the fewest number of bits per digital sample required to produce an  
25 acceptable location estimate;  
forwarding the fewest number of bits per sample from said signal collection system to  
the TDOA location processor and estimating the location of the mobile transmitter  
on the basis of said bits received from said signal collection system as well as bits  
received from other signal collection systems; and  
30 determining whether additional bits per sample are necessary to achieve a desired level  
of accuracy of the location estimate, and, if so, sending additional bits per sample

over the communications link from the signal collection system to the TDOA location processor.

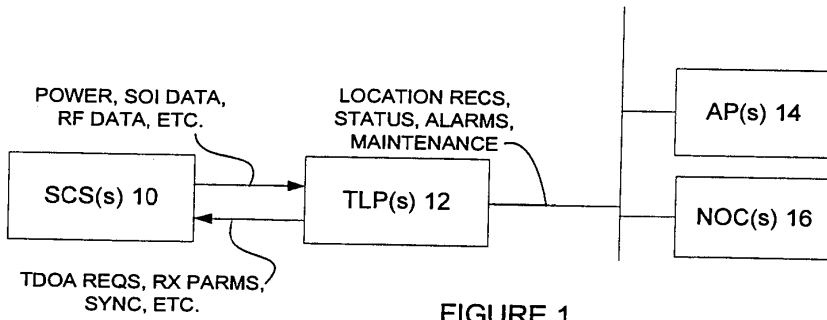


FIGURE 1

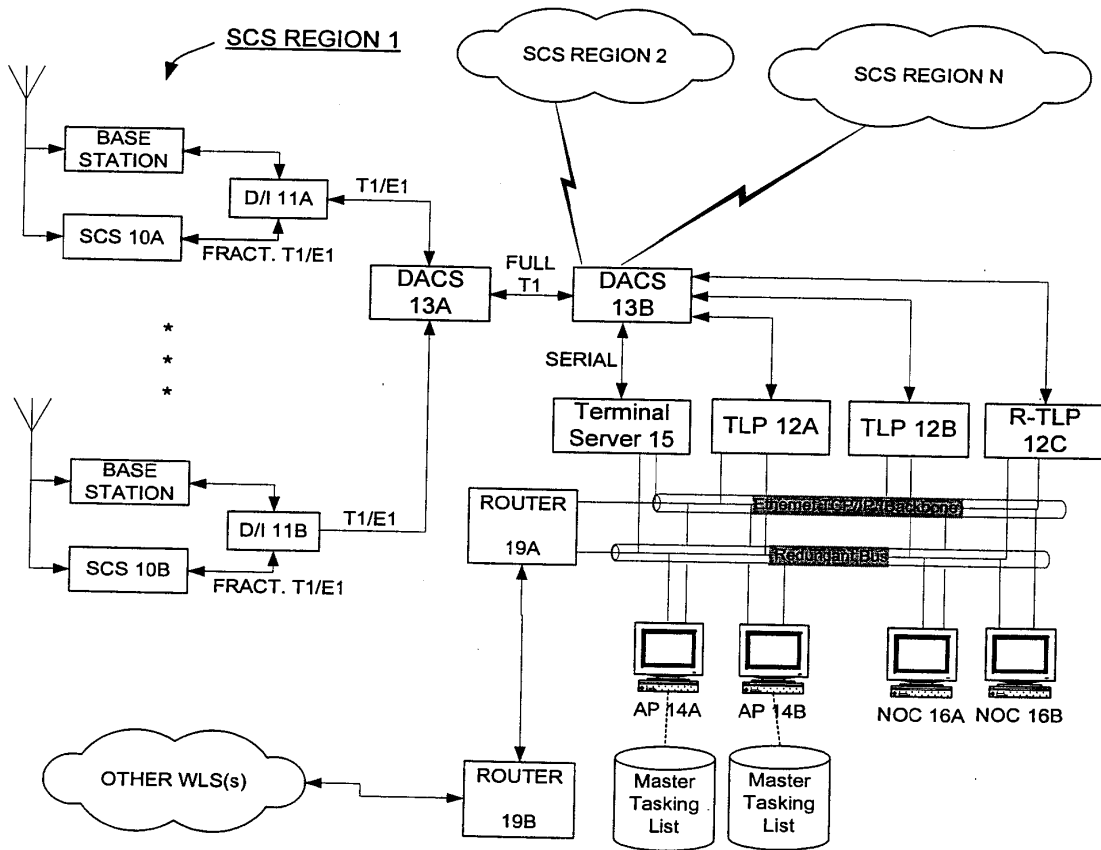


FIGURE 1A

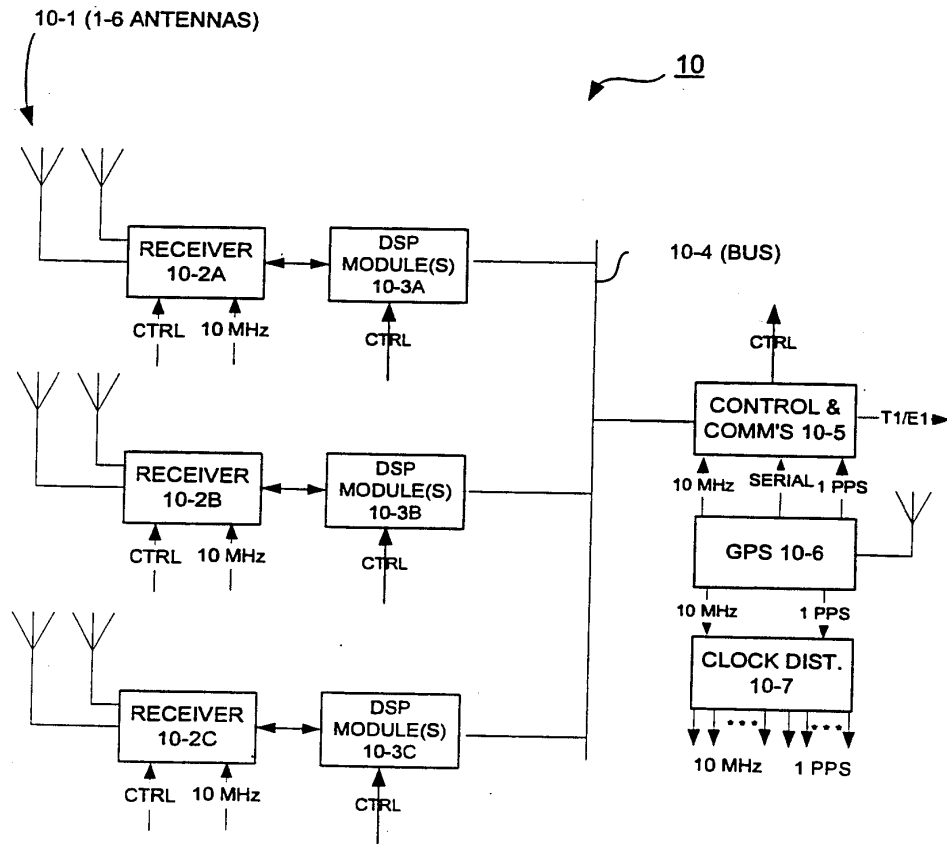


FIGURE 2

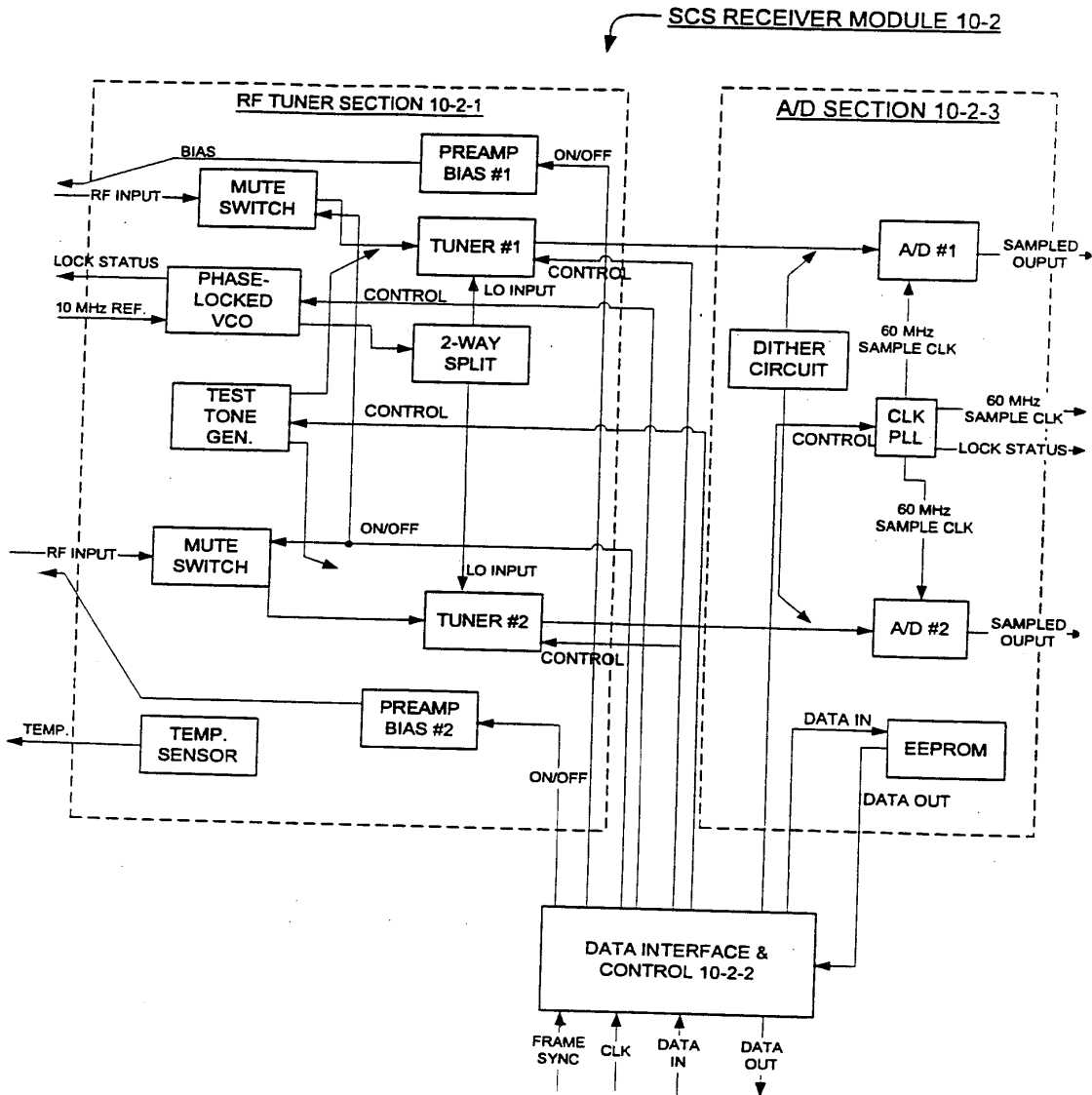


FIGURE 2A

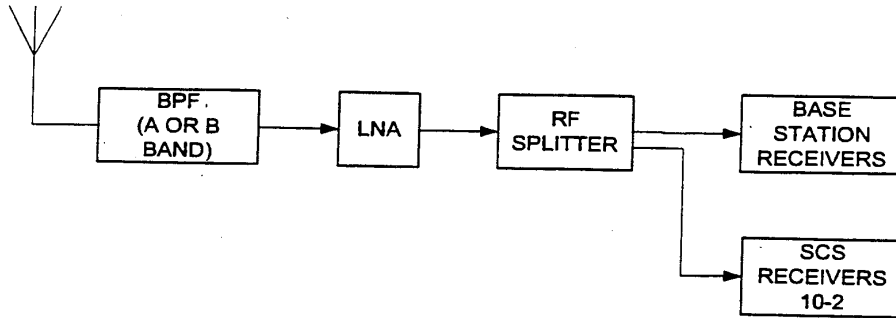


FIGURE 2B

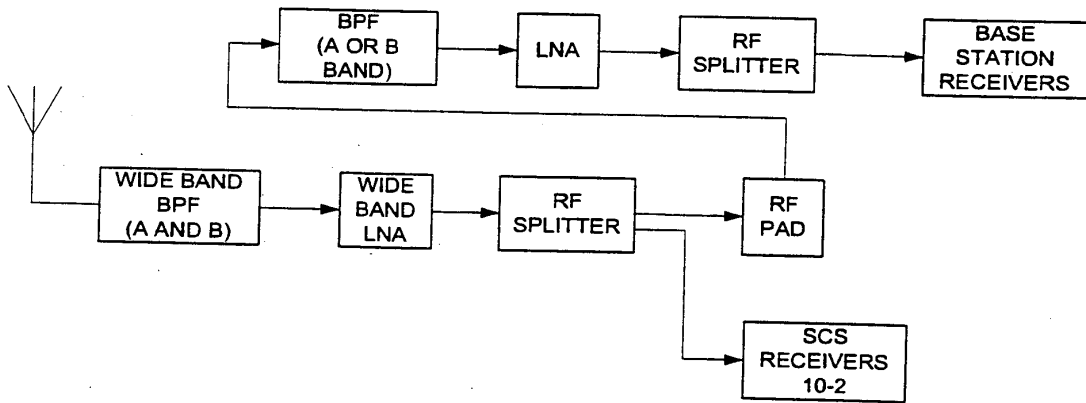


FIGURE 2C

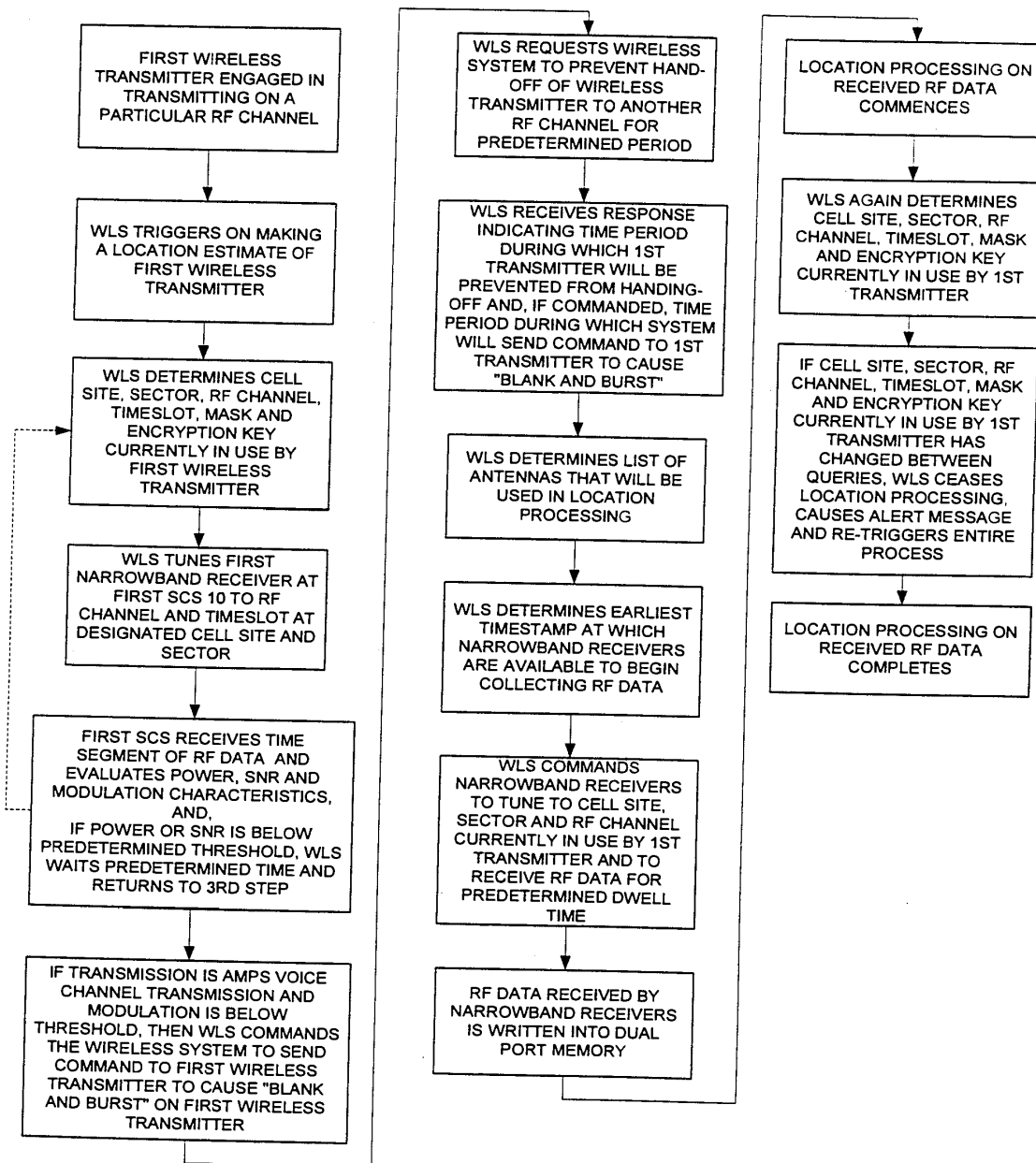


FIGURE 2C-1





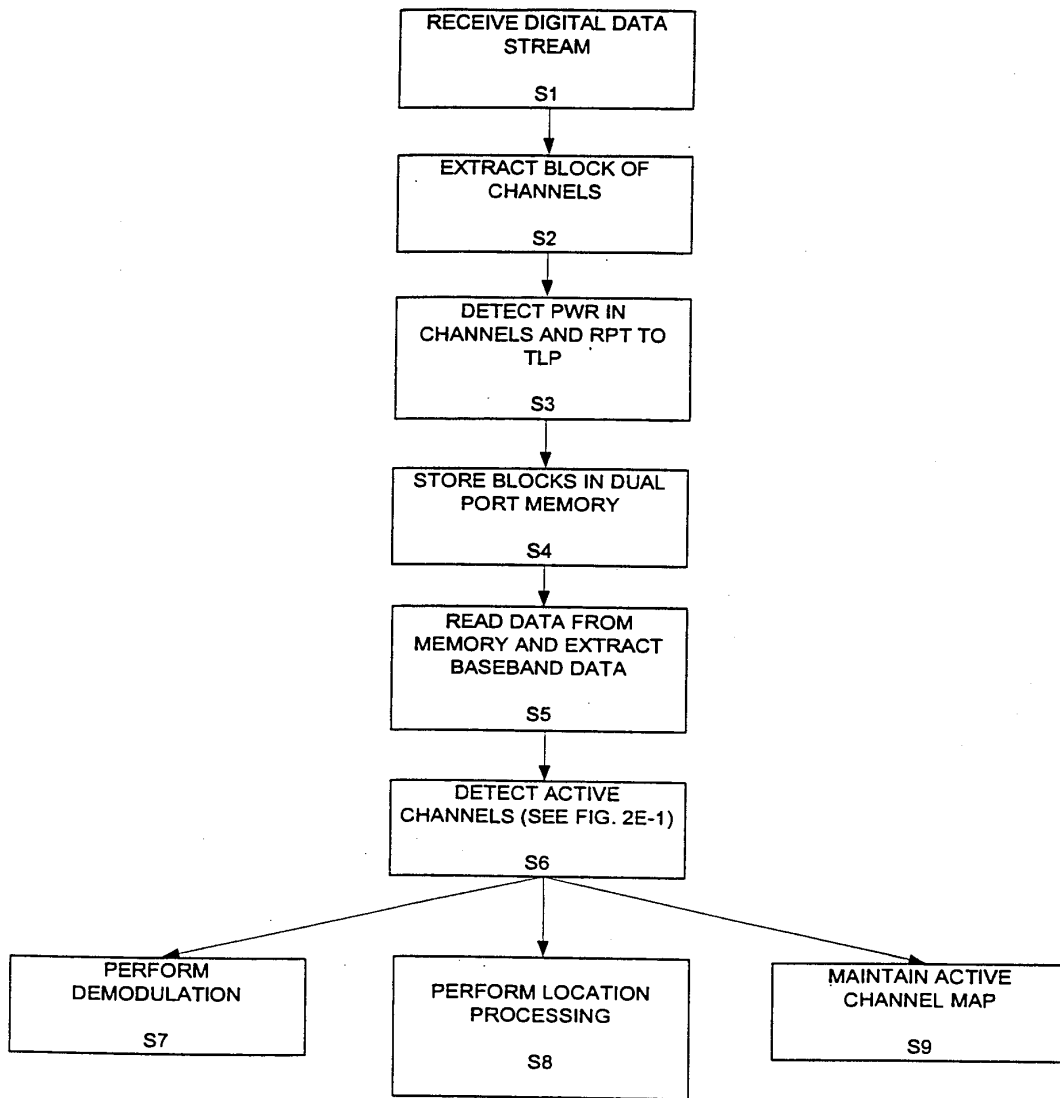


FIGURE 2E

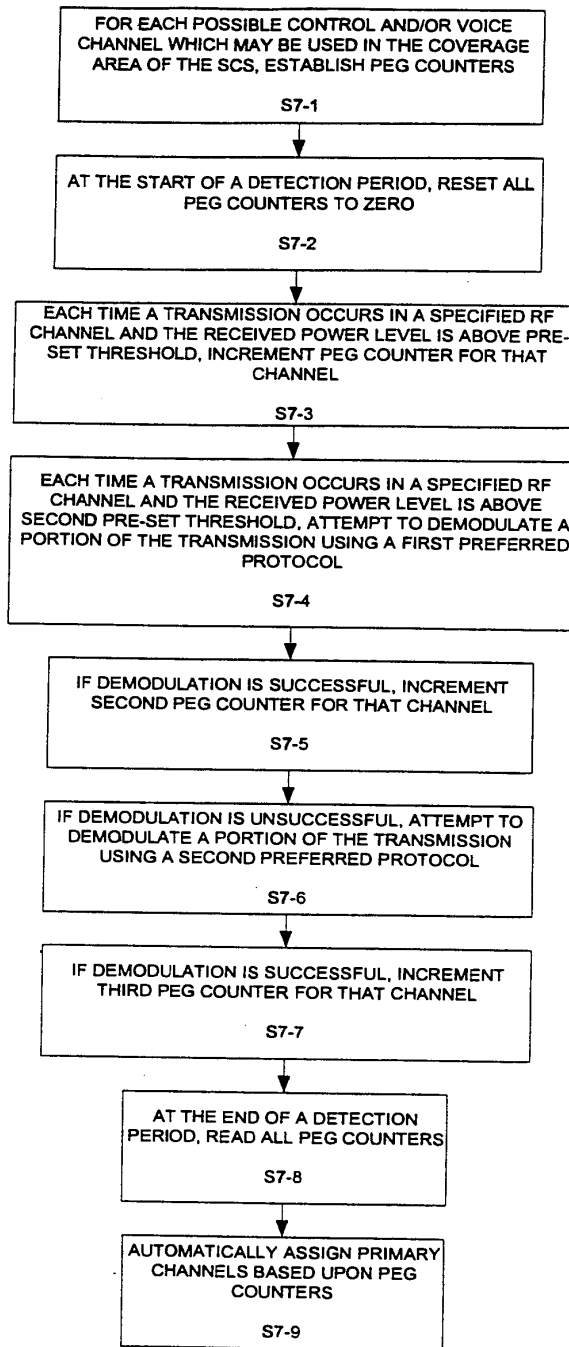


FIGURE 2E-1

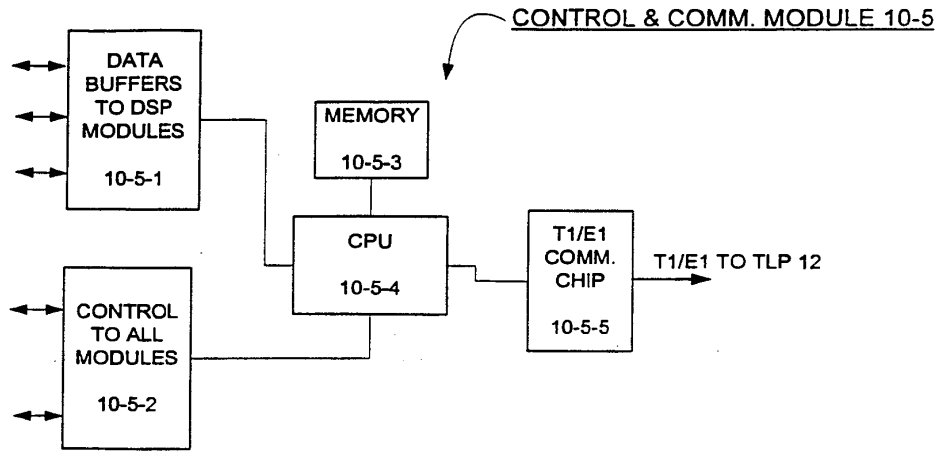


FIGURE 2F

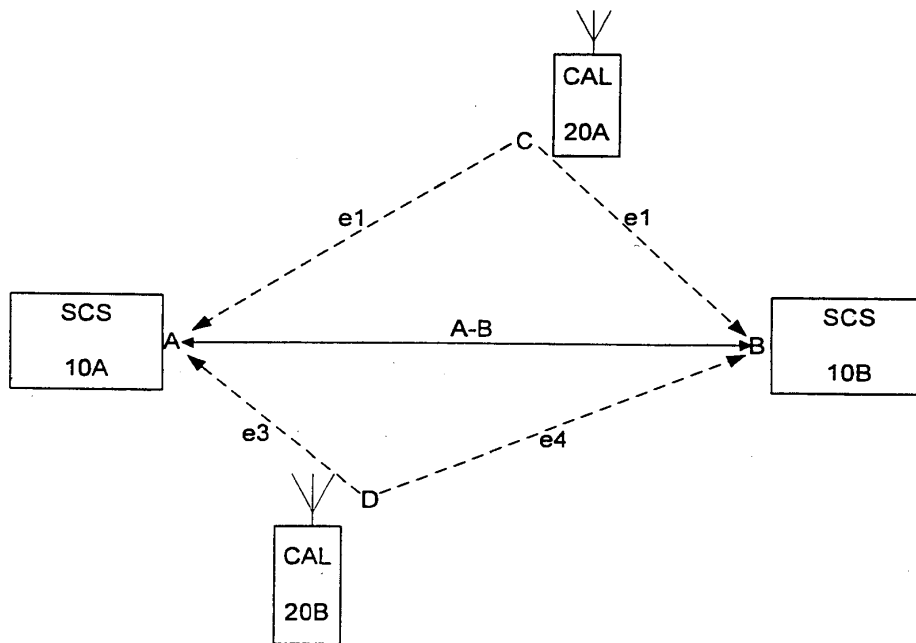


FIGURE 2G

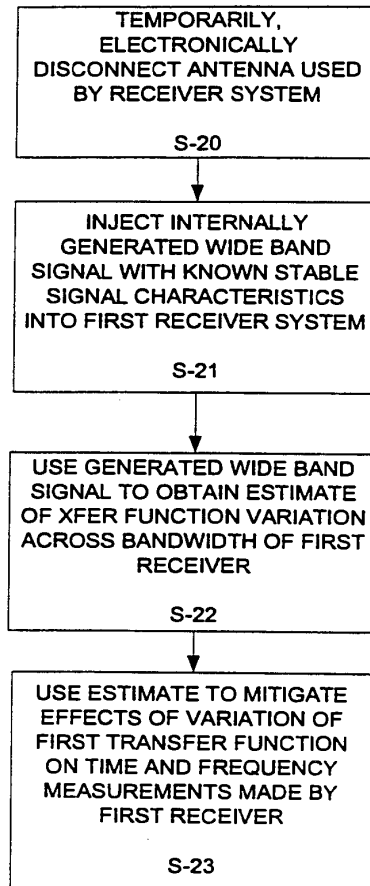


FIGURE 2H

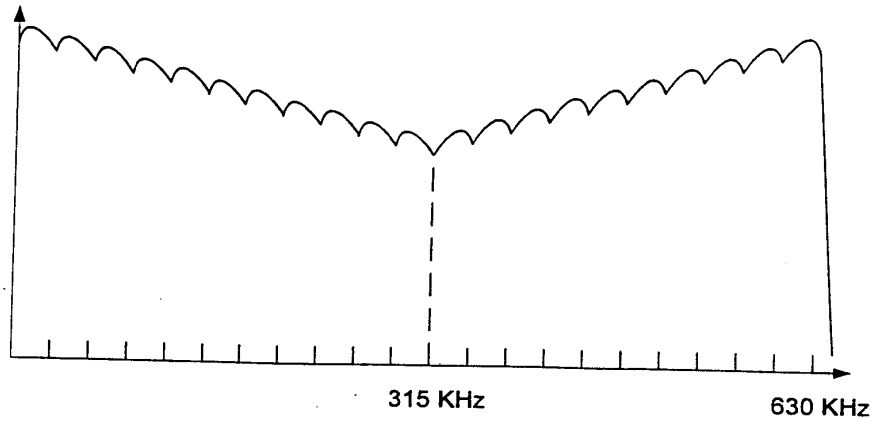


FIGURE 2I

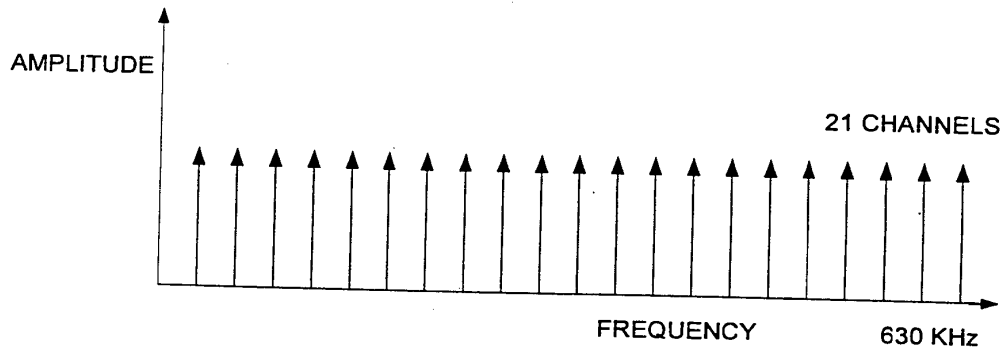


FIGURE 2J

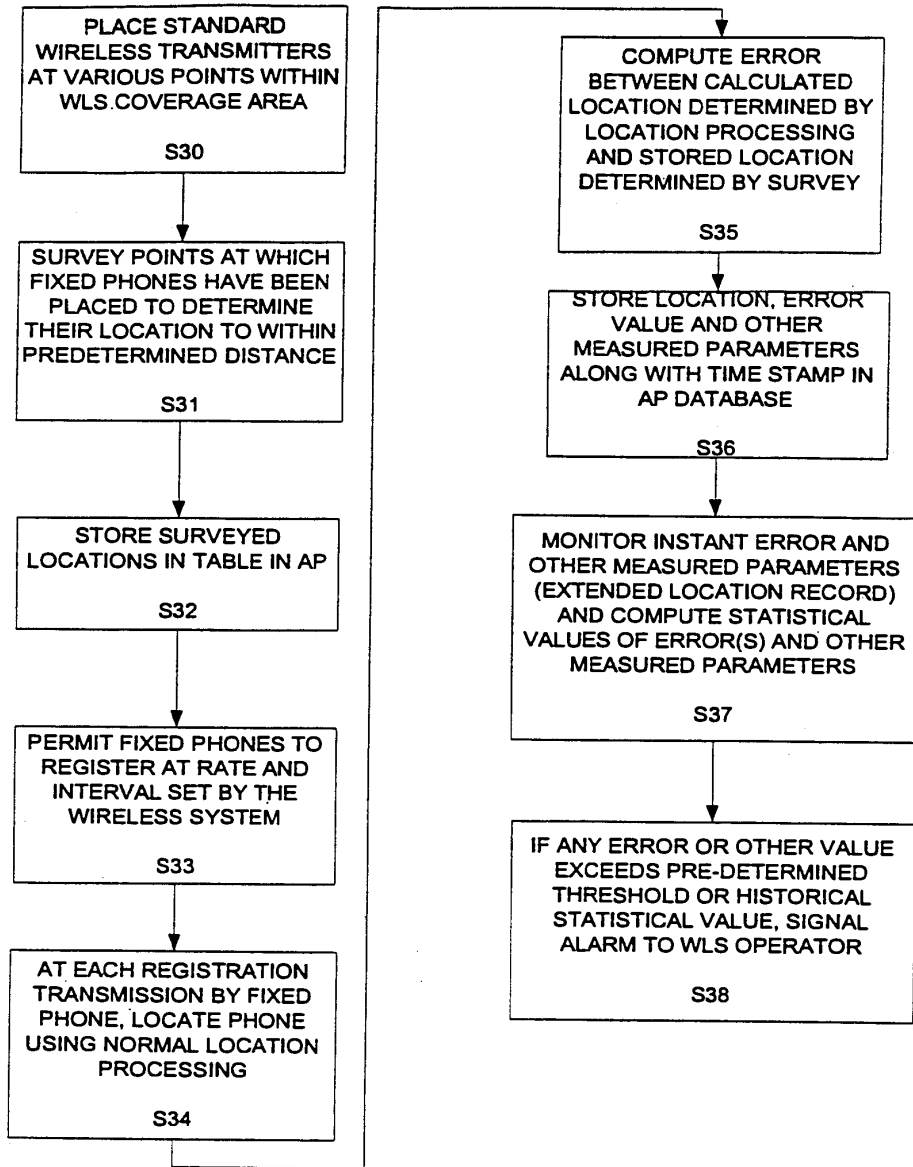


FIGURE 2K

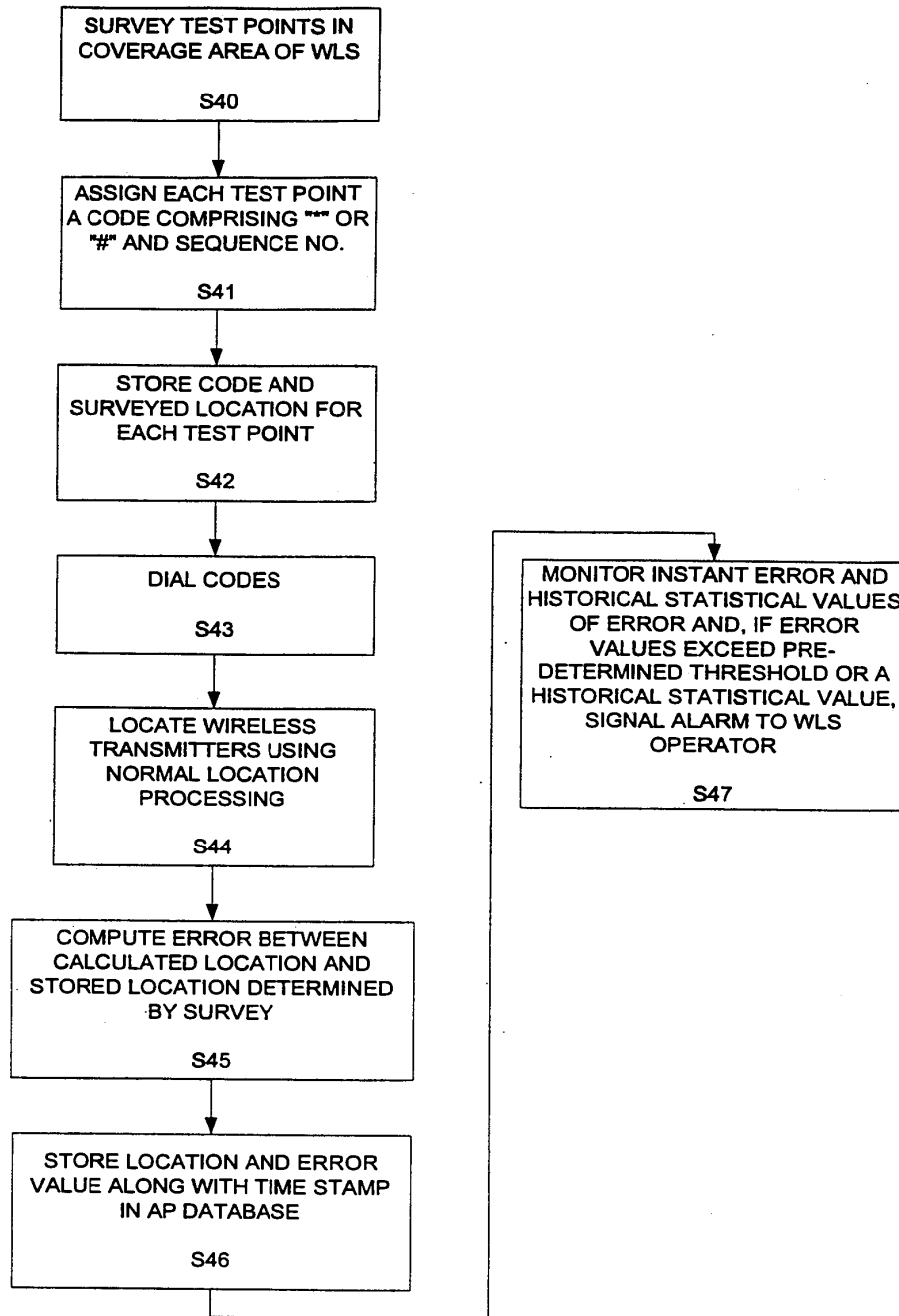


FIGURE 2L



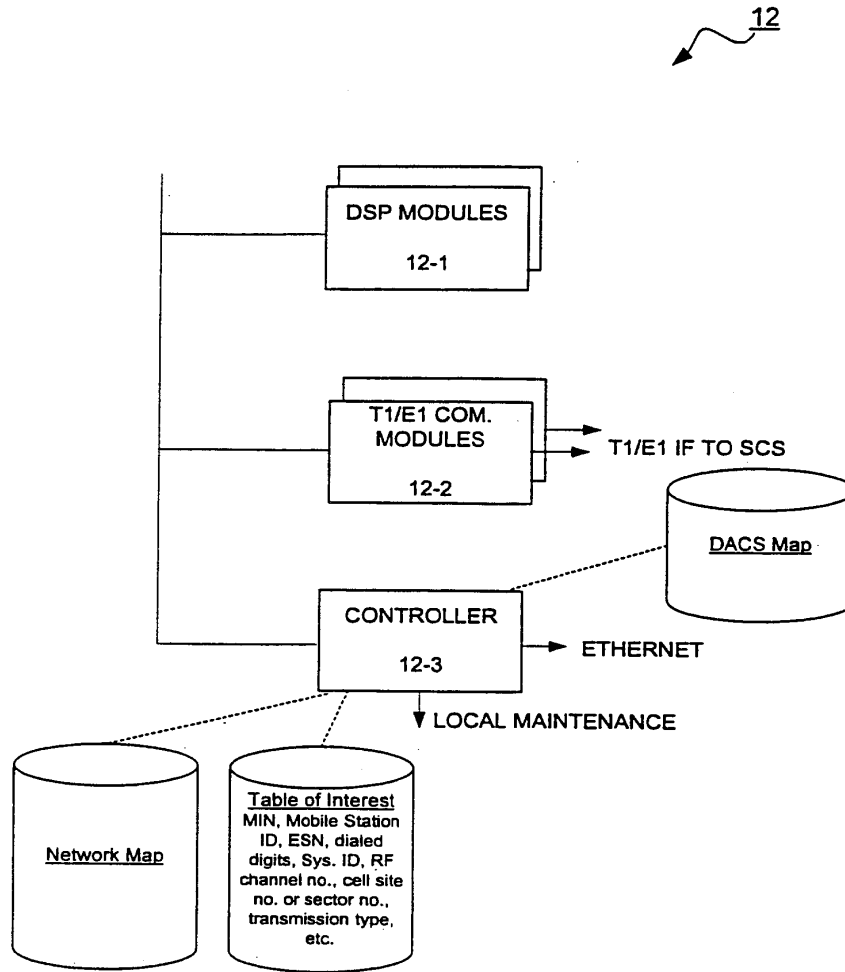


FIGURE 3

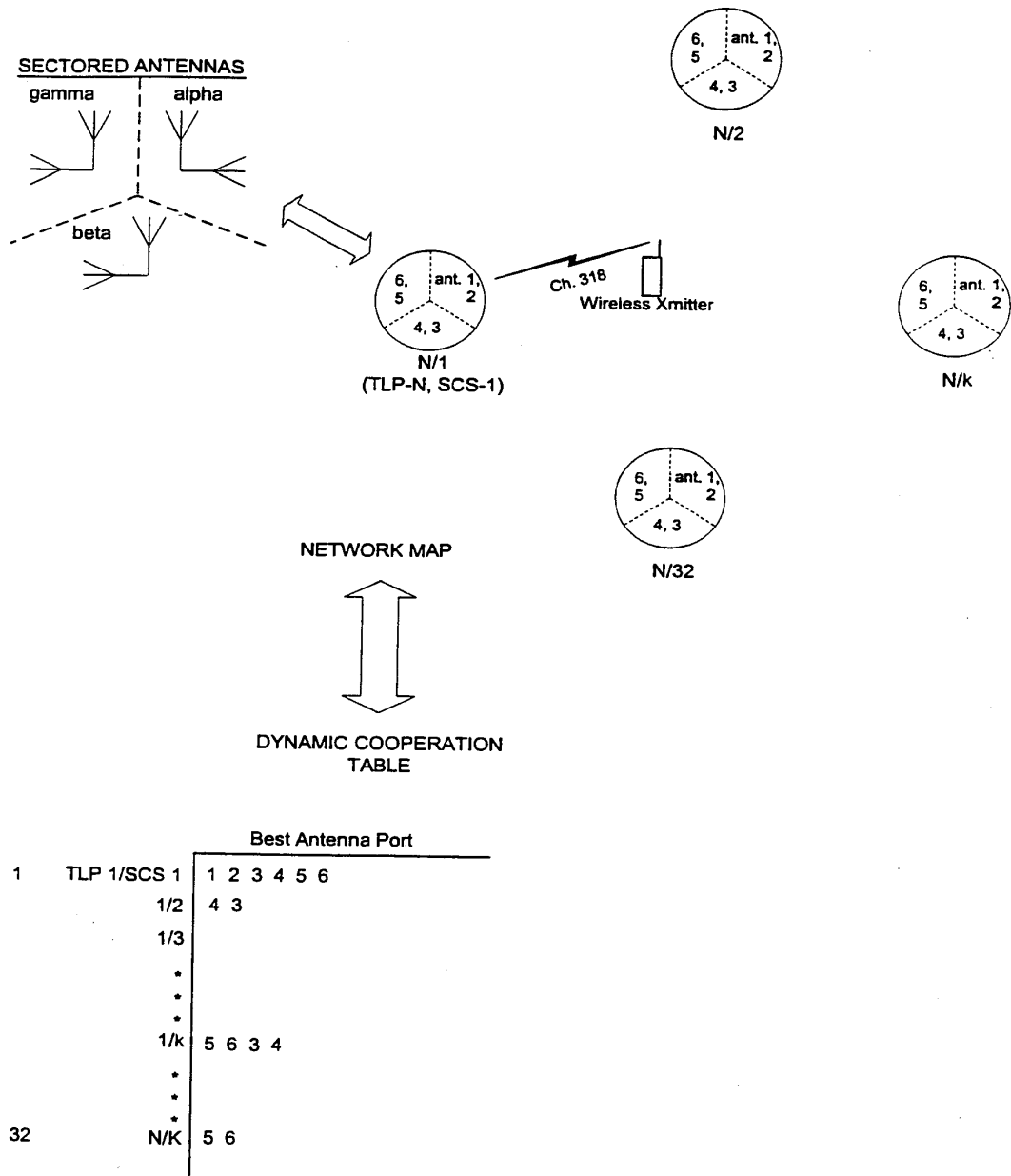


FIGURE 3A

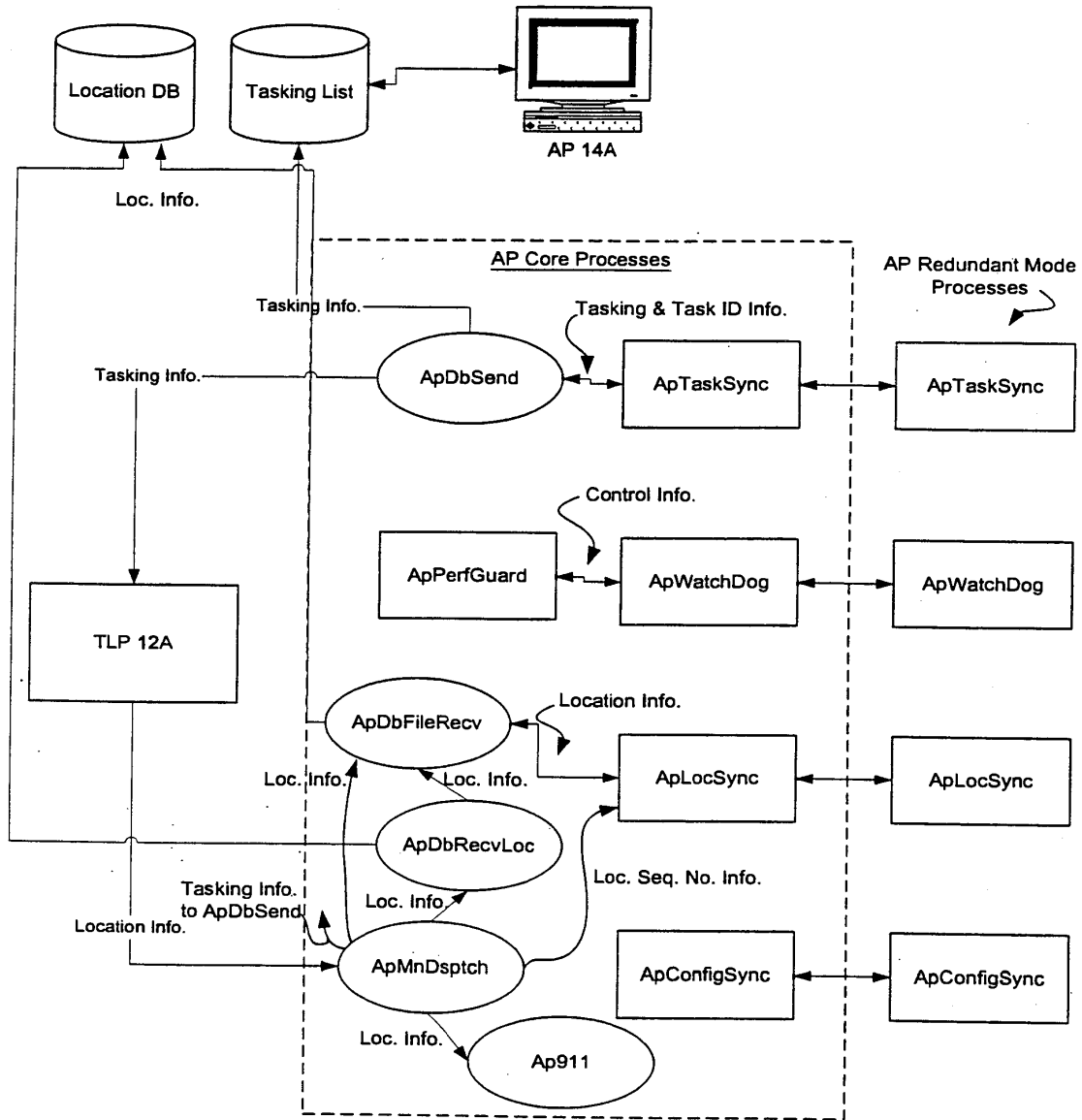


FIGURE 4

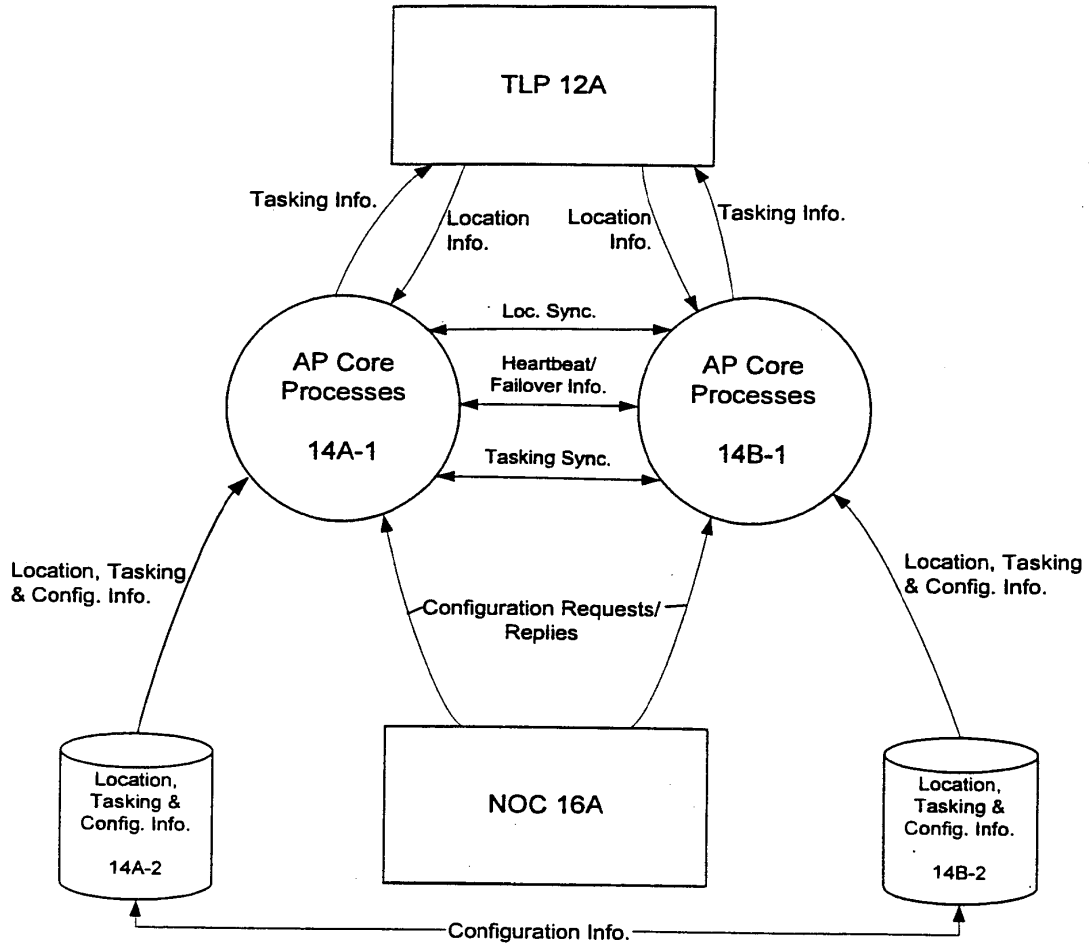


FIGURE 4A

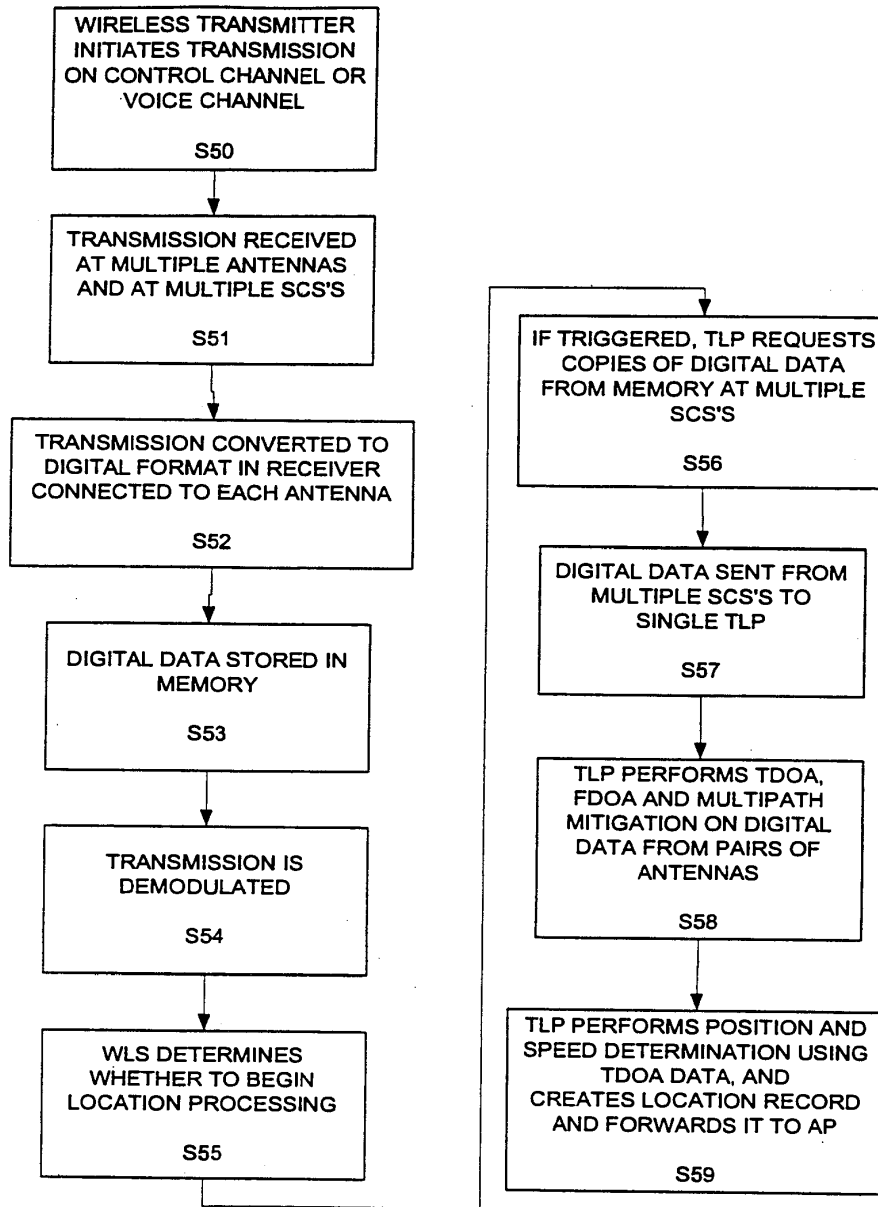


FIGURE 5

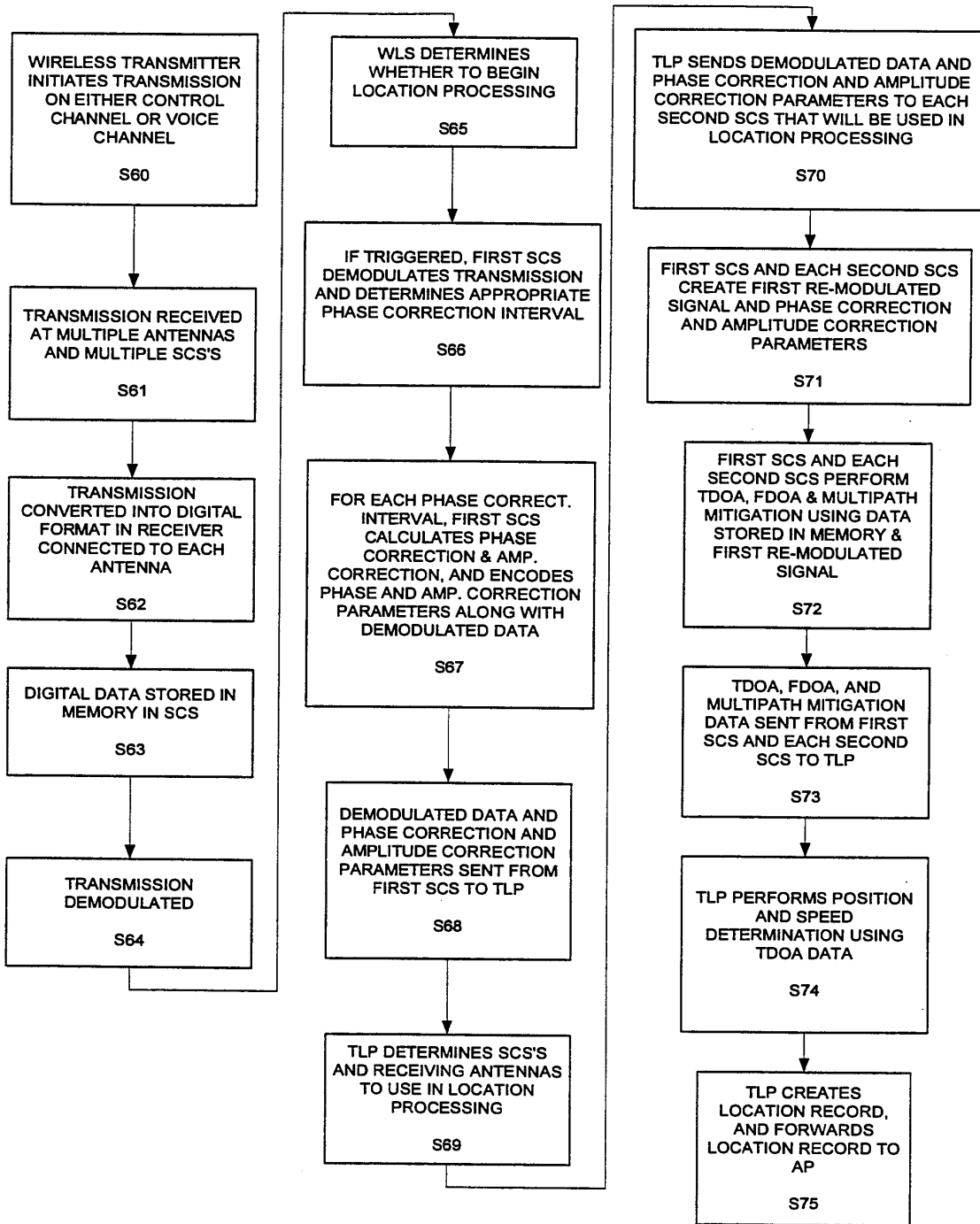


FIGURE 6

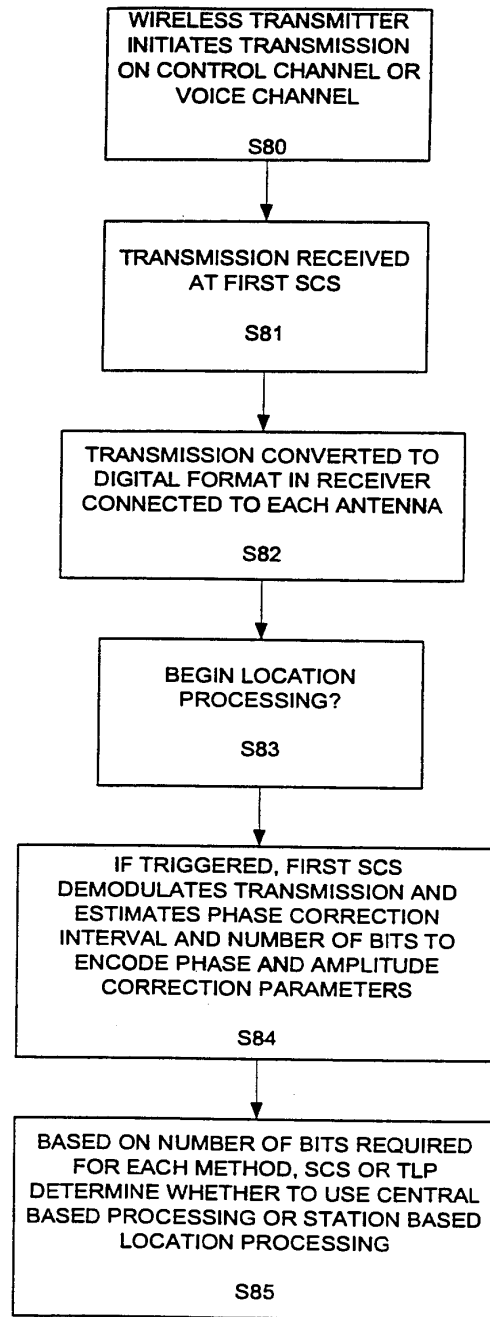


FIGURE 7

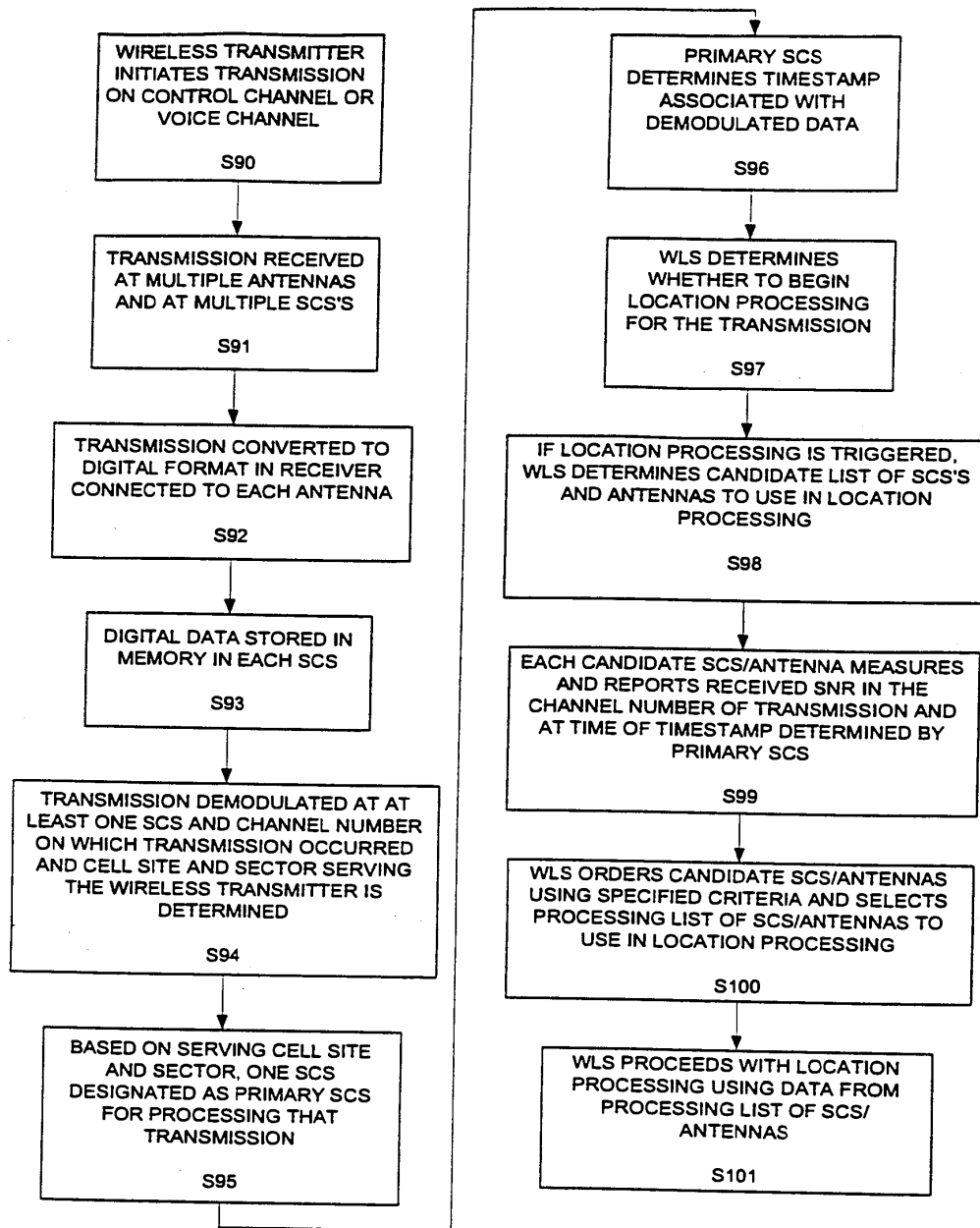


FIGURE 8



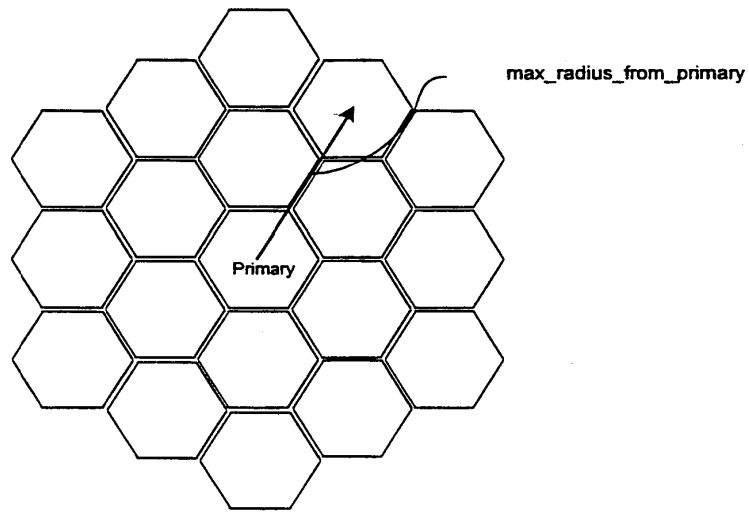


FIGURE 9

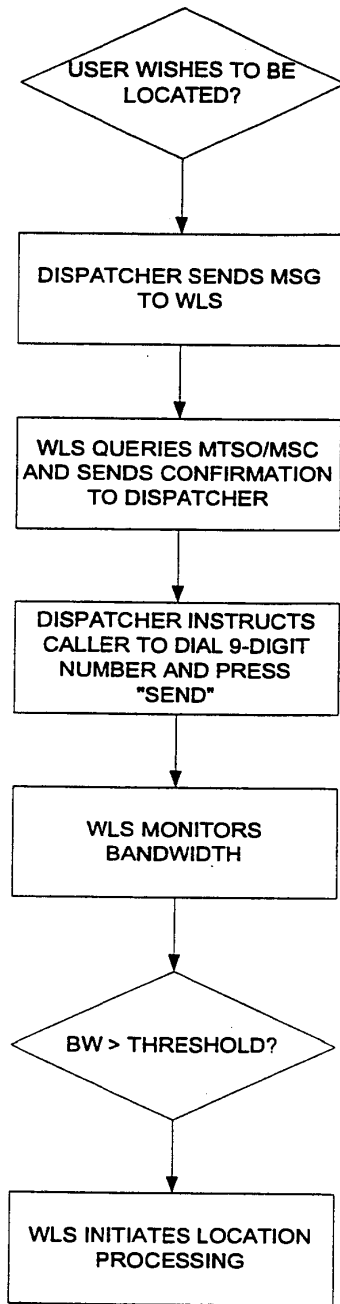


FIGURE 10A

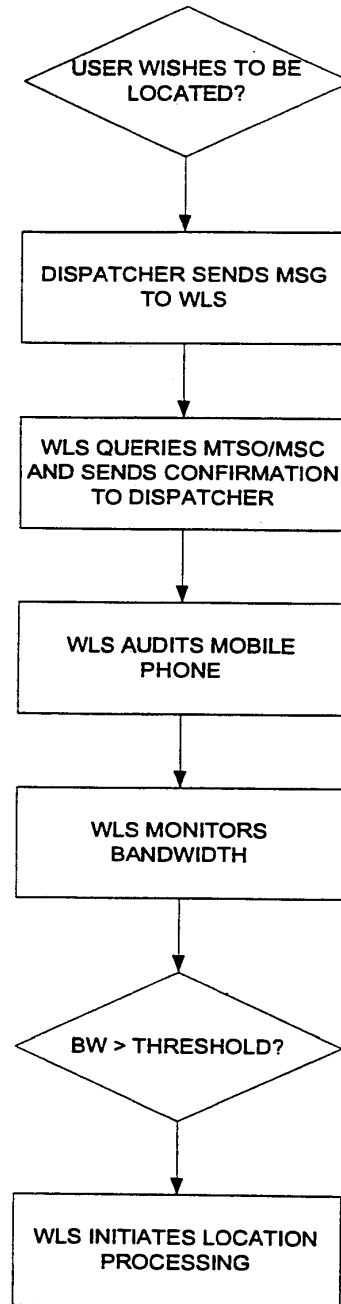


FIGURE 10B

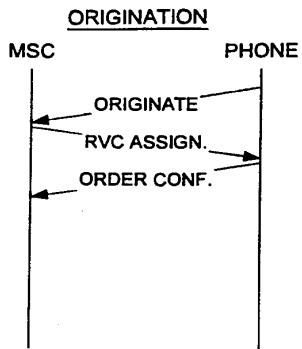


FIGURE 11A

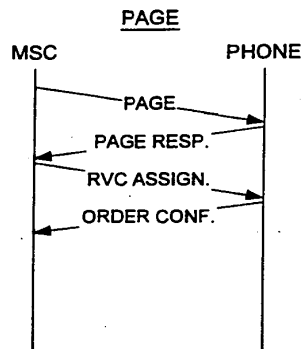


FIGURE 11B

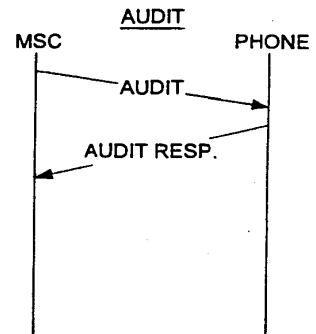


FIGURE 11C

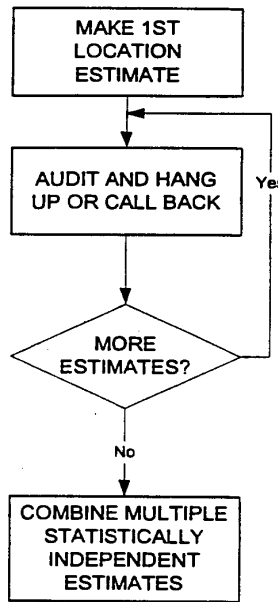


FIGURE 11D

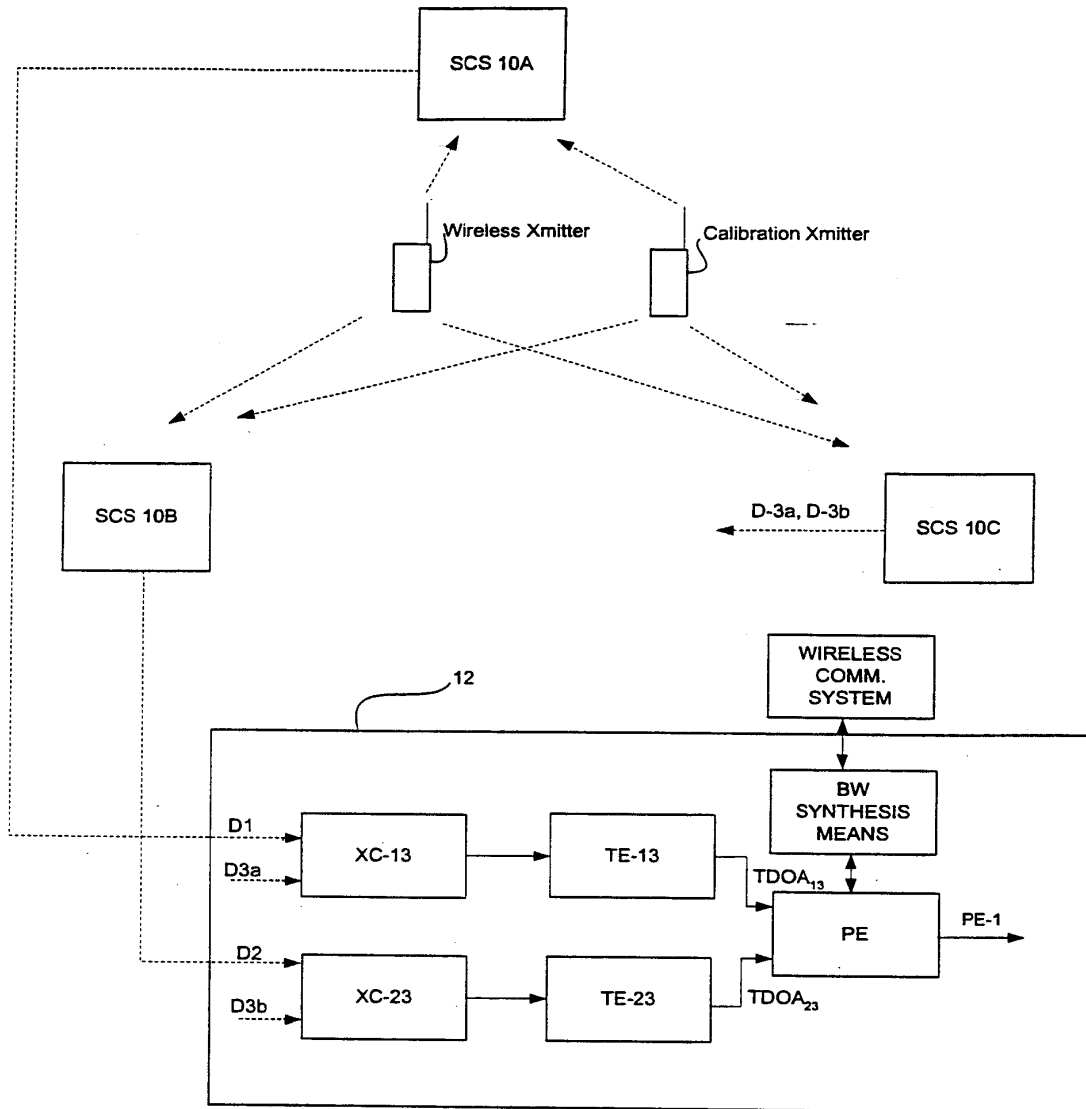


FIGURE 12A

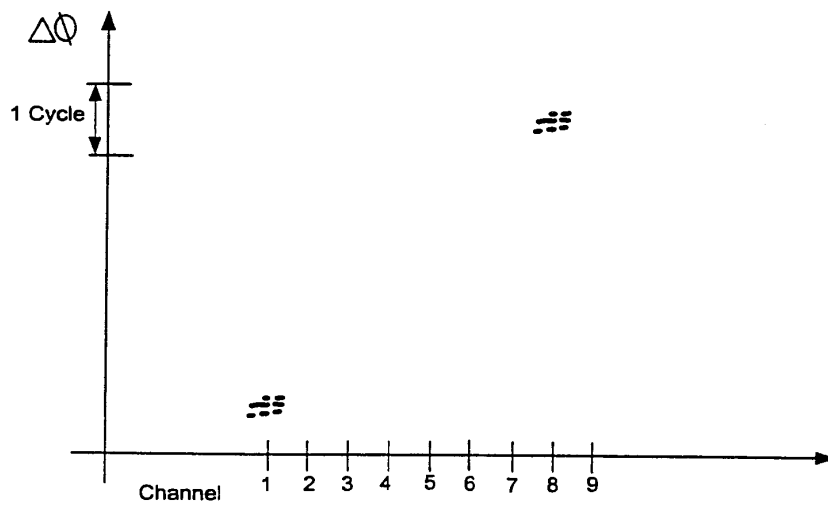


FIGURE 12B

(12) INTERNATIONAL APPLICATION PUBLISHED UNDER THE PATENT COOPERATION TREATY (PCT)

(19) World Intellectual Property Organization  
International Bureau



(43) International Publication Date  
21 December 2000 (21.12.2000)

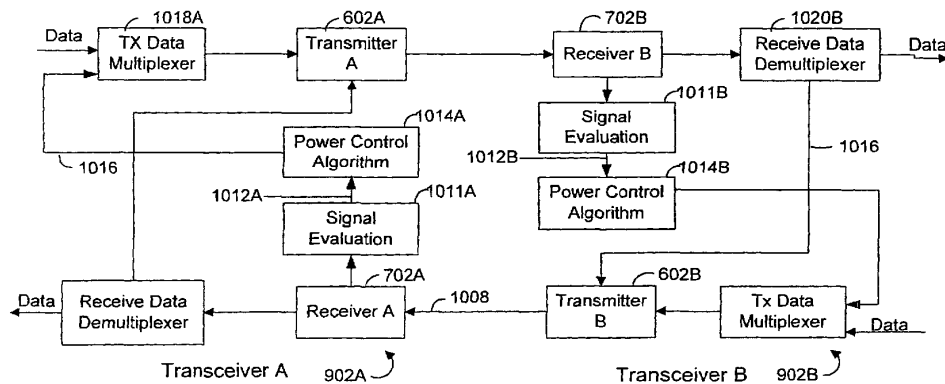
PCT

(10) International Publication Number  
WO 00/77949 A1

- (51) International Patent Classification<sup>7</sup>: H04B 7/005
  - (21) International Application Number: PCT/US00/16084
  - (22) International Filing Date: 13 June 2000 (13.06.2000)
  - (25) Filing Language: English
  - (26) Publication Language: English
  - (30) Priority Data:  
09/332,501 14 June 1999 (14.06.1999) US
  - (71) Applicant: TIME DOMAIN CORPORATION  
[US/US]; Cummings Research Park, 7057 Old Madison Pike, Huntsville, AL 35806 (US).
  - (72) Inventors: RICHARDS, James, L.; 58 Boning Road, Fayetteville, TN 37334 (US). FULLERTON, Larry, W.; 120 Wimbledon Road, Brownsboro, AL 35741 (US). COWIE, Ivan, A.; 418 Eastview Drive, Madison, AL 35758 (US).
  - (74) Agents: SOKOHL, Robert, E. et al.; Sterne, Kessler, Goldstein & Fox P.L.L.C., Suite 600, 1100 New York Avenue, N.W., Washington, DC 20005-3934 (US).
  - (81) Designated States (national): AE, AG, AL, AM, AT, AU, AZ, BA, BB, BG, BR, BY, CA, CH, CN, CR, CU, CZ, DE, DK, DM, DZ, EE, ES, FI, GB, GD, GE, GH, GM, HR, HU, ID, IL, IN, IS, JP, KE, KG, KP, KR, KZ, LC, LK, LR, LS, LT, LU, LV, MA, MD, MG, MK, MN, MW, MX, MZ, NO, NZ, PL, PT, RO, RU, SD, SE, SG, SI, SK, SL, TJ, TM, TR, TT, TZ, UA, UG, UZ, VN, YU, ZA, ZW.
  - (84) Designated States (regional): ARIPO patent (GH, GM, KE, LS, MW, MZ, SD, SL, SZ, TZ, UG, ZW), Eurasian patent (AM, AZ, BY, KG, KZ, MD, RU, TJ, TM), European patent (AT, BE, CH, CY, DE, DK, ES, FI, FR, GB, GR, IE, IT, LU, MC, NL, PT, SE), OAPI patent (BF, BJ, CF, CG, CI, CM, GA, GN, GW, ML, MR, NE, SN, TD, TG).
- Published:**  
 — With international search report.  
 — Before the expiration of the time limit for amending the claims and to be republished in the event of receipt of amendments.

[Continued on next page]

(54) Title: SYSTEM AND METHOD FOR IMPULSE RADIO POWER CONTROL



(57) Abstract: A system and method for impulse radio power control wherein a first transceiver transmits an impulse radio signal to a second transceiver. A power control update is calculated according to a performance measurement of the signal received at the second transceiver. The transmitter power of either transceiver, depending on the particular embodiment, is adjusted according to the power control update. Various performance measurements are employed according to the current invention to calculate a power control update, including bit error rate, signal-to-noise ratio, and received signal strength. Interference is thereby reduced, which is particularly important where multiple impulse radios are operating in close proximity and their transmission interfere with one another. Reducing the transmitter power of each radio to a level that produces satisfactory reception increases the total number of radios that can operate in an area without saturation. Reducing transmitter power also increases transceiver efficiency.

WO 00/77949 A1



---

*For two-letter codes and other abbreviations, refer to the "Guidance Notes on Codes and Abbreviations" appearing at the beginning of each regular issue of the PCT Gazette.*

## SYSTEM AND METHOD FOR IMPULSE RADIO POWER CONTROL

### *Background of the Invention*

#### **Field of the Invention**

5           The present invention generally relates to wireless communications, and more specifically, to a system and a method for impulse radio power control.

#### **Related Art**

10           Recent advances in communications technology have enabled an emerging, revolutionary ultra wideband technology (UWB) called impulse radio communications systems (hereinafter called impulse radio).

15           Impulse radio was first fully described in a series of patents, including U.S. Patent Nos. 4,641,317 (issued February 3, 1987), 4,813,057 (issued March 14, 1989), 4,979,186 (issued December 18, 1990) and 5,363,108 (issued November 8, 1994) to Larry W. Fullerton. A second generation of impulse radio patents include U.S. Patent Nos. 5,677,927 (issued October 14, 1997), 5,687,169 (issued November 11, 1997) and 5,832,035 (issued November 3, 1998) to Fullerton *et al.* These patent documents are incorporated herein by reference.

20           Uses of impulse radio systems are described in U.S. Patent Application No. 09/332,502, entitled, "*System and Method for Intrusion Detection Using a Time Domain Radar Array*," and U.S. Patent Application No. 09/332,503, entitled, "*Wide Area Time Domain Radar Array*," both filed the same day as the present application, June 14, 1999, both of which are assigned to the assignee of the present invention, and both of which are incorporated herein by reference.

25           Basic impulse radio transmitters emit short pulses approaching a Gaussian monocycle with tightly controlled pulse-to-pulse intervals. Impulse radio systems typically use pulse position modulation, which is a form of time



modulation where the value of each instantaneous sample of a modulating signal is caused to modulate the position of a pulse in time.

For impulse radio communications, the pulse-to-pulse interval is varied on a pulse-by-pulse basis by two components: an information component and a pseudo-random code component. Unlike direct sequence spread spectrum systems, the pseudo-random code for impulse radio communications is not necessary for energy spreading because the monocycle pulses themselves have an inherently wide bandwidth. Instead, the pseudo-random code of an impulse radio system is used for channelization, energy smoothing in the frequency domain and for interference suppression.

Generally speaking, an impulse radio receiver is a direct conversion receiver with a cross correlator front end. The front end coherently converts an electromagnetic pulse train of monocycle pulses to a baseband signal in a single stage. The data rate of the impulse radio transmission is typically a fraction of the periodic timing signal used as a time base. Because each data bit modulates the time position of many pulses of the periodic timing signal, this yields a modulated, coded timing signal that comprises a train of identically shaped pulses for each single data bit. The impulse radio receiver integrates multiple pulses to recover the transmitted information.

In a multi-user environment, impulse radio depends, in part, on processing gain to achieve rejection of unwanted signals. Because of the extremely high processing gain achievable with impulse radio, much higher dynamic ranges are possible than are commonly achieved with other spread spectrum methods, some of which must use power control in order to have a viable system. Further, if power is kept to a minimum in an impulse radio system, this will allow closer operation in co-site or nearly co-site situations where two impulse radios must operate concurrently, or where an impulse radio and a narrow band radio must operate close by one another and share the same band.

In some multi-user environments where there is a high density of users in a coverage area or where data rates are so high that processing gain is marginal,

power control may be used to reduce the multi-user background noise to improve the number of channels available and the aggregate traffic density of the area.

Thus, one area in which further improvement is desired is in power control for impulse radio systems. Briefly stated, power control generally refers to adjusting the transmitter output power to the minimum necessary power to achieve acceptable signal reception at an impulse radio receiver. If the received signal power drops too low, the transmitter power should be increased. Conversely, if the received signal power rises too high, the transmitter power should be decreased. This potentially reduces interference with other services and increases the channelization (and thus, capacity) available to a multi-user impulse radio system.

Power control for impulse radio systems have been proposed. For example, in their paper entitled, "*Performance of Local Power Control In Peer to Peer Impulse Radio Networks with Bursty Traffic*," Kolenchery *et al.* describe the combined use of a variable data rate with power control. Kolenchery *et al.* propose a system that uses closed loop power control with an open loop adjustment of power associated with each change in data rate to maintain constant signal to noise during the transient event of changing the data rate. However, the system proposed by Kolenchery *et al.* does not make full use of the properties of UWB. Further, Kolenchery *et al.* do not describe a system and method for measuring signal quality and applying such a system and method to power control.

A need therefore exists for an improved system and a method for impulse radio power control.

### *Summary of the Invention*

Briefly stated, the present invention is directed to a system and method for impulse radio power control. A first transceiver transmits an impulse radio signal to a second transceiver. A power control update is calculated according to a performance measurement of the impulse radio signal received at the second transceiver. The transmitter power of either transceiver, depending on the particular embodiment, is adjusted according to the power control update.

An advantage of the current invention is that interference is reduced. This is particularly important where multiple impulse radios are operating in close proximity (*e.g.*, a densely utilized network), and their transmissions interfere with one another. Reducing the transmitter power of each radio to a level that produces satisfactory reception increases the total number of radios that can operate in an area without excess interference.

Another advantage of the current invention is that impulse radios can be more energy efficient. Reducing transmitter power to only the level required to produce satisfactory reception allows a reduction in the total power consumed by the transceiver, and thereby increases its efficiency.

Various performance measurements are employed according to the current invention to calculate a power control update. Bit error rate, signal-to-noise ratio, and received signal strength are three examples of performance measurements that can be used alone or in combination to form a power control update. These performance measurements vary by accuracy and time required to achieve an update. An appropriate performance measurement can be chosen based on the particular environment and application.

In one embodiment, where a pulse train including a quantity  $N_{\text{train}}$  of pulses is transmitted for each bit of information, the output power of a transceiver is controlled by controlling the quantity  $N_{\text{train}}$  of pulses according to the power control update. For example, in an embodiment where the quantity  $N_{\text{train}}$  of pulses includes a quantity  $N_{\text{period}}$  of periods, and each period includes a quantity  $N_{\text{pulses-per-period}}$  of pulses, the output power of a transceiver can be controlled by controlling

the quantity  $N_{\text{period}}$  of periods. Alternatively, the output power can be controlled by controlling the quantity  $N_{\text{pulses-per-period}}$  of pulses.

5 In one embodiment, where the output power of the first transceiver is controlled, the power control update is determined at the second transceiver and then sent from the second transceiver to the first transceiver. Alternatively, the second transceiver sends at least one performance measurement to the first transceiver, and the first transceiver then determines the power control update based on the performance measurement(s).

10 Further features and advantages of the invention, as well as the structure and operation of various embodiments of the invention, are described in detail below with reference to the accompanying drawings.

### ***Brief Description of the Figures***

15 Within the accompanying drawings, the convention used to describe signal connections requires that a signal line end at a junction with another signal line to indicate a connection. Two signal lines that cross indicate no connection at the crossing. The present invention will now be described with reference to the accompanying drawings, wherein:

Fig. 1A illustrates a representative Gaussian Monocycle waveform in the time domain;

20 Fig. 1B illustrates the frequency domain amplitude of the Gaussian Monocycle of Fig. 1A;

Fig. 2A illustrates a pulse train comprising pulses as in Fig. 1A;

Fig. 2B illustrates the frequency domain amplitude of the waveform of Fig. 2A;

25 Fig. 3 illustrates the frequency domain amplitude of a sequence of time coded pulses;

Fig. 4 illustrates a typical received signal and interference signal;

Fig. 5A illustrates a typical geometrical configuration giving rise to multipath received signals;

Fig. 5B illustrates exemplary multipath signals in the time domain;

Fig. 6 illustrates a representative impulse radio transmitter functional diagram that does not include power control;

5 Fig. 7 illustrates a representative impulse radio receiver functional diagram that does not include power control;

Fig. 8A illustrates a representative received pulse signal at the input to the correlator;

Fig 8B illustrates a sequence of representative impulse signals in the correlation process;

10 Fig 8C illustrates the potential locus of results as a function of the various potential template time positions;

Fig. 9 illustrates an example environment of an impulse radio communication system;

15 Fig 10 is an exemplary flow diagram of a two transceiver system employing power control according to one embodiment of the present invention;

Fig. 11 is an exemplary diagram of an impulse receiver including power control functions according to one embodiment of the present invention;

Fig. 12 is a detailed representation of one embodiment of the detection process in Fig. 10;

20 Fig. 13 is a detailed block diagram of one embodiment of the signal evaluation process in Fig. 11;

Fig. 14 illustrates an alternate processing method for Fig. 13;

Fig. 15 is a detailed block diagram of one embodiment of the signal evaluation process in Fig. 11;

25 Fig. 16 illustrates an alternate processing method for Fig. 15;

Fig. 17 illustrates a lock detection and signal combination function used by the signal evaluation function of Fig. 11;

Fig. 18 is a flowchart that describes a method of power control according to the present invention;

Fig. 19 is a flowchart that describes controlling the transmitter power of a first transceiver according to the power control updates;

Fig. 20 is a flow diagram illustrating the control dynamics of one embodiment of the present invention;

5 Fig. 21 is a flow diagram illustrating the control dynamics of a system including Signal to Noise Ratio measurement;

Fig. 22 is a flow diagram illustrating the control dynamics of a system including Bit Error Rate measurement;

10 Fig. 23 is a flow diagram illustrating the control dynamics of a system employing log mapping of Bit Error Rate measurements;

Fig. 24 is a flow diagram illustrating the control dynamics of a system that incorporates auto power control and cross power control;

Fig. 25 illustrates an embodiment of a power control algorithm employing auto-control with power level messaging;

15 Fig. 26 illustrates an embodiment of a power control algorithm where auto-control and cross control are implemented in combination;

Fig. 27 illustrates two signals having different pulse peak power;

Fig. 28 illustrates periods of two subcarriers; and

20 Fig. 29 is a flow diagram illustrating the control dynamics of a system employing gain expansion power control.

In the drawings, like reference numbers generally indicate identical, functionally similar, and/or structurally similar elements. The drawing in which an element first appears is indicated by the leftmost digit(s) in the corresponding reference number.

### *Detailed Description of the Preferred Embodiments*

#### **I. Impulse Radio Basics**

This section is directed to technology basics and provides the reader with an introduction to impulse radio concepts, as well as other relevant aspects of communications theory. This section includes subsections relating to waveforms, pulse trains, coding for energy smoothing and channelization, modulation, reception and demodulation, interference resistance, processing gain, capacity, multipath and propagation, distance measurement, and qualitative and quantitative characteristics of these concepts. It should be understood that this section is provided to assist the reader with understanding the present invention, and should not be used to limit the scope of the present invention.

Impulse radio refers to a radio system based on short, low duty cycle pulses. An ideal impulse radio waveform is a short Gaussian monocycle. As the name suggests, this waveform attempts to approach one cycle of radio frequency (RF) energy at a desired center frequency. Due to implementation and other spectral limitations, this waveform may be altered significantly in practice for a given application. Most waveforms with enough bandwidth approximate a Gaussian shape to a useful degree.

Impulse radio can use many types of modulation, including AM, time shift (also referred to as pulse position) and M-ary versions. The time shift method has simplicity and power output advantages that make it desirable. In this document, the time shift method is used as an illustrative example.

In impulse radio communications, the pulse-to-pulse interval can be varied on a pulse-by-pulse basis by two components: an information component and a pseudo-random code component. Generally, conventional spread spectrum systems make use of pseudo-random codes to spread the normally narrow band information signal over a relatively wide band of frequencies. A conventional spread spectrum receiver correlates these signals to retrieve the original information signal. Unlike conventional spread spectrum systems, the pseudo-random code for impulse radio communications is not necessary for energy

spreading because the monocycle pulses themselves have an inherently wide bandwidth. Instead, the pseudo-random code is used for channelization, energy smoothing in the frequency domain, resistance to interference, and reducing the interference potential to nearby receivers.

5           The impulse radio receiver is typically a direct conversion receiver with a cross correlator front end in which the front end coherently converts an electromagnetic pulse train of monocycle pulses to a baseband signal in a single stage. The baseband signal is the basic information signal for the impulse radio communications system. It is often found desirable to include a subcarrier with  
10           the baseband signal to help reduce the effects of amplifier drift and low frequency noise. The subcarrier that is typically implemented alternately reverses modulation according to a known pattern at a rate faster than the data rate. This same pattern is used to reverse the process and restore the original data pattern just before detection. This method permits alternating current (AC) coupling of  
15           stages, or equivalent signal processing to eliminate direct current (DC) drift and errors from the detection process. This method is described in detail in U.S. Patent No. 5,677,927 to Fullerton *et al.*

          In impulse radio communications utilizing time shift modulation, each data bit typically time position modulates many pulses of the periodic timing  
20           signal. This yields a modulated, coded timing signal that comprises a train of identically shaped pulses for each single data bit. The impulse radio receiver integrates multiple pulses to recover the transmitted information.

### **I.1. Waveforms**

25           Impulse radio refers to a radio system based on short, low duty cycle pulses. In the widest bandwidth embodiment, the resulting waveform approaches one cycle per pulse at the center frequency. In more narrow band embodiments, each pulse consists of a burst of cycles usually with some spectral shaping to control the bandwidth to meet desired properties such as out of band emissions



or in-band spectral flatness, or time domain peak power or burst off time attenuation.

For system analysis purposes, it is convenient to model the desired waveform in an ideal sense to provide insight into the optimum behavior for detail design guidance. One such waveform model that has been useful is the Gaussian monocycle as shown in Fig. 1A. This waveform is representative of the transmitted pulse produced by a step function into an ultra-wideband antenna. The basic equation normalized to a peak value of 1 is as follows:

$$f_{mono}(t) = \sqrt{e} \left( \frac{t}{\sigma} \right) e^{\frac{-t^2}{2\sigma^2}}$$

10 Where,

$\sigma$  is a time scaling parameter,

$t$  is time,

$f_{mono}(t)$  is the waveform voltage, and

$e$  is the natural logarithm base.

15 The frequency domain spectrum of the above waveform is shown in Fig. 1B. The corresponding equation is:

$$F_{mono}(f) = (2\pi)^{\frac{3}{2}} \sigma f e^{-2(\pi\sigma f)^2}$$

The center frequency ( $f_c$ ), or frequency of peak spectral density is:

$$f_c = \frac{1}{2\pi\sigma}$$

20 These pulses, or bursts of cycles, may be produced by methods described in the patents referenced above or by other methods that are known to one of

ordinary skill in the art. Any practical implementation will deviate from the ideal mathematical model by some amount. In fact, this deviation from ideal may be substantial and yet yield a system with acceptable performance. This is especially true for microwave implementations, where precise waveform shaping is difficult to achieve. These mathematical models are provided as an aid to describing ideal operation and are not intended to limit the invention. In fact, any burst of cycles that adequately fills a given bandwidth and has an adequate on-off attenuation ratio for a given application will serve the purpose of this invention.

### I.2. A Pulse Train

Impulse radio systems can deliver one or more data bits per pulse; however, impulse radio systems more typically use pulse trains, not single pulses, for each data bit. As described in detail in the following example system, the impulse radio transmitter produces and outputs a train of pulses for each bit of information.

Prototypes built by the inventors have pulse repetition frequencies including 0.7 and 10 megapulses per second (Mpps, where each megapulse is  $10^6$  pulses). Figs. 2A and 2B are illustrations of the output of a typical 10 Mpps system with uncoded, unmodulated, 0.5 nanosecond (ns) pulses 102. Fig. 2A shows a time domain representation of this sequence of pulses 102. Fig. 2B, which shows 60 MHz at the center of the spectrum for the waveform of Fig. 2A, illustrates that the result of the pulse train in the frequency domain is to produce a spectrum comprising a set of lines 204 spaced at the frequency of the 10 Mpps pulse repetition rate. When the full spectrum is shown, the envelope of the line spectrum follows the curve of the single pulse spectrum 104 of Fig. 1B. For this simple uncoded case, the power of the pulse train is spread among roughly two hundred comb lines. Each comb line thus has a small fraction of the total power and presents much less of an interference problem to receiver sharing the band.

It can also be observed from Fig. 2A that impulse radio systems typically have very low average duty cycles resulting in average power significantly lower

than peak power. The duty cycle of the signal in the present example is 0.5%, based on a 0.5 ns pulse in a 100 ns interval.

### I.3. Coding for Energy Smoothing and Channelization

5 For high pulse rate systems, it may be necessary to more finely spread the spectrum than is achieved by producing comb lines. This may be done by pseudo-randomly positioning each pulse relative to its nominal position.

10 Fig. 3 is a plot illustrating the impact of a pseudo-noise (PN) code dither on energy distribution in the frequency domain (A pseudo-noise, or PN code is a set of time positions defining the pseudo-random positioning for each pulse in a sequence of pulses). Fig. 3, when compared to Fig. 2B, shows that the impact of using a PN code is to destroy the comb line structure and spread the energy more uniformly. This structure typically has slight variations which are characteristic of the specific code used.

15 The PN code also provides a method of establishing independent communication channels using impulse radio. PN codes can be designed to have low cross correlation such that a pulse train using one code will seldom collide on more than one or two pulse positions with a pulses train using another code during any one data bit time. Since a data bit may comprise hundreds of pulses, this represents a substantial attenuation of the unwanted channel.

### 20 I.4. Modulation

Any aspect of the waveform can be modulated to convey information. Amplitude modulation, phase modulation, frequency modulation, time shift modulation and M-ary versions of these have been proposed. Both analog and digital forms have been implemented. Of these, digital time shift modulation has  
25 been demonstrated to have various advantages and can be easily implemented using a correlation receiver architecture.

Digital time shift modulation can be implemented by shifting the coded time position by an additional amount (that is, in addition to PN code dither) in

response to the information signal. This amount is typically very small relative to the PN code shift. In a 10 Mpps system with a center frequency of 2 GHz., for example, the PN code may command pulse position variations over a range of 100 ns; whereas, the information modulation may only deviate the pulse position by 150 ps.

Thus, in a pulse train of  $n$  pulses, each pulse is delayed a different amount from its respective time base clock position by an individual code delay amount plus a modulation amount, where  $n$  is the number of pulses associated with a given data symbol digital bit.

Modulation further smooths the spectrum, minimizing structure in the resulting spectrum.

#### **I.5. Reception and Demodulation**

Clearly, if there were a large number of impulse radio users within a confined area, there might be mutual interference. Further, while the PN coding minimizes that interference, as the number of users rises, the probability of an individual pulse from one user's sequence being received simultaneously with a pulse from another user's sequence increases. Impulse radios are able to perform in these environments, in part, because they do not depend on receiving *every* pulse. The impulse radio receiver performs a correlating, synchronous receiving function (at the RF level) that uses a statistical sampling and combining of many pulses to recover the transmitted information.

Impulse radio receivers typically integrate from 1 to 1000 or more pulses to yield the demodulated output. The optimal number of pulses over which the receiver integrates is dependent on a number of variables, including pulse rate, bit rate, interference levels, and range.

### I.6. Interference Resistance

Besides channelization and energy smoothing, the PN coding also makes impulse radios highly resistant to interference from all radio communications systems, including other impulse radio transmitters. This is critical as any other signals within the band occupied by an impulse signal potentially interfere with the impulse radio. Since there are currently no unallocated bands available for impulse systems, they must share spectrum with other conventional radio systems without being adversely affected. The PN code helps impulse systems discriminate between the intended impulse transmission and interfering transmissions from others.

Fig. 4 illustrates the result of a narrow band sinusoidal interference signal 402 overlaying an impulse radio signal 404. At the impulse radio receiver, the input to the cross correlation would include the narrow band signal 402, as well as the received ultrawide-band impulse radio signal 404. The input is sampled by the cross correlator with a PN dithered template signal 406. Without PN coding, the cross correlation would sample the interfering signal 402 with such regularity that the interfering signals could cause significant interference to the impulse radio receiver. However, when the transmitted impulse signal is encoded with the PN code dither (and the impulse radio receiver template signal 406 is synchronized with that identical PN code dither) the correlation samples the interfering signals pseudo-randomly. The samples from the interfering signal add incoherently, increasing roughly according to square root of the number of samples integrated; whereas, the impulse radio samples add coherently, increasing directly according to the number of samples integrated. Thus, integrating over many pulses overcomes the impact of interference.

### I.7. Processing Gain

Impulse radio is resistant to interference because of its large processing gain. For typical spread spectrum systems, the definition of processing gain, which quantifies the decrease in channel interference when wide-band

communications are used, is the ratio of the bandwidth of the channel to the bit rate of the information signal. For example, a direct sequence spread spectrum system with a 10 kHz information bandwidth and a 10 MHz channel bandwidth yields a processing gain of 1000 or 30 dB. However, far greater processing gains  
5 are achieved with impulse radio systems, where for the same 10 KHz information bandwidth is spread across a much greater 2 GHz. channel bandwidth, the theoretical processing gain is 200,000 or 53 dB.

### I.8. Capacity

It has been shown theoretically, using signal to noise arguments, that  
10 thousands of simultaneous voice channels are available to an impulse radio system as a result of the exceptional processing gain, which is due to the exceptionally wide spreading bandwidth.

For a simplistic user distribution, with N interfering users of equal power equidistant from the receiver, the total interference signal to noise ratio as a result  
15 of these other users can be described by the following equation:

$$V^2_{tot} = \frac{N\sigma^2}{\sqrt{Z}}$$

Where  $V^2_{tot}$  is the total interference signal to noise ratio variance, at the  
receiver;  
20 N is the number of interfering users;  
 $\sigma^2$  is the signal to noise ratio variance resulting from one of the interfering signals with a single pulse cross correlation; and  
Z is the number of pulses over which the receiver integrates to recover the modulation.

This relationship suggests that link quality degrades gradually as the number of simultaneous users increases. It also shows the advantage of integration gain. The number of users that can be supported at the same interference level increases by the square root of the number of pulses integrated.

5                   **I.9.    Multipath and Propagation**

One of the striking advantages of impulse radio is its resistance to multipath fading effects. Conventional narrow band systems are subject to multipath through the Rayleigh fading process, where the signals from many delayed reflections combine at the receiver antenna according to their relative phase. This results in possible summation or possible cancellation, depending on the specific propagation to a given location. This also results in potentially wild signal strength fluctuations in mobile applications, where the mix of multipath signals changes for every few feet of travel.

Impulse radios, however, are substantially resistant to these effects. Impulses arriving from delayed multipath reflections typically arrive outside of the correlation time and thus are ignored. This process is described in detail with reference to Figs. 5A and 5B. In Fig. 5A, three propagation paths are shown. The direct path is the shortest. It represents the straight line distance between the transmitter and the receiver. Path 1 represents a grazing multipath reflection, which is very close to the direct path. Path 2 represents a distant multipath reflection. Also shown are elliptical (or, in space, ellipsoidal) traces that represent other possible locations for reflections with the same time delay.

Fig. 5B represents a time domain plot of the received waveform from this multipath propagation configuration. This figure comprises three doublet pulses as shown in Fig. 1A. The direct path signal is the reference signal and represents the shortest propagation time. The path 1 signal is delayed slightly and actually overlaps and enhances the signal strength at this delay value. Note that the reflected waves are reversed in polarity. The path 2 signal is delayed sufficiently that the waveform is completely separated from the direct path signal. If the

correlator template signal is positioned at the direct path signal, the path 2 signal will produce no response. It can be seen that only the multipath signals resulting from very close reflectors have any effect. The bulk of the multipath signals, which are substantially delayed, are removed from the correlation process and are ignored.

The multipath signals delayed less than one quarter wave (one quarter wave is about 1.5 inches, or 3.5cm at 2 GHz center frequency) are the only signals that will attenuate the direct path signal. This is the reflection from the first Fresnel zone, and this property is shared with narrow band signals; however, impulse radio is highly resistant to all other Fresnel zone reflections. The ability to avoid the highly variable attenuation from multipath gives impulse radio significant performance advantages.

#### **I.10. Distance Measurement**

Impulse systems can measure distances to extremely fine resolution because of the absence of ambiguous cycles in the waveform. Narrow band systems, on the other hand, are limited to the modulation envelope and cannot easily distinguish precisely which RF cycle is associated with each data bit because the cycle-to-cycle amplitude differences are so small they are masked by link or system noise. Since the impulse radio waveform has no multi-cycle ambiguity, this allows positive determination of the waveform position to less than a wavelength - potentially, down to the noise floor of the system. This time position measurement can be used to measure propagation delay to determine link distance, and once link distance is known, to transfer a time reference to an equivalently high degree of precision. The inventors of the present invention have built systems that have shown the potential for centimeter distance resolution, which is equivalent to about 30 ps of time transfer resolution. See, for example, commonly owned, co-pending applications 09/045,929, filed March 23, 1998, titled "Ultrawide-Band Position Determination System and Method", and 09/083,993, filed May 26, 1998, titled "System and Method for Distance



Measurement by Inphase and Quadrature Signals in a Radio System", both of which are incorporated herein by reference.

## II. Exemplary Transceiver Implementation

### II.1. Transmitter

5 An exemplary embodiment of an impulse radio transmitter 602 of an impulse radio communication system having one subcarrier channel will now be described with reference to Fig. 6.

The transmitter 602 comprises a time base 604 that generates a periodic timing signal 606. The time base 604 typically comprises a voltage controlled oscillator (VCO), or the like, having a high timing accuracy and low jitter, on the order of picoseconds (ps). The voltage control to adjust the VCO center frequency is set at calibration to the desired center frequency used to define the transmitter's nominal pulse repetition rate. The periodic timing signal 606 is supplied to a precision timing generator 608.

15 The precision timing generator 608 supplies synchronizing signals 610 to the code source 612 and utilizes the code source output 614 together with an internally generated subcarrier signal (which is optional) and an information signal 616 to generate a modulated, coded timing signal 618.

The code source 612 comprises a storage device such as a random access memory (RAM), read only memory (ROM), or the like, for storing suitable PN codes and for outputting the PN codes as a code signal 614. Alternatively, maximum length shift registers or other computational means can be used to generate the PN codes.

25 An information source 620 supplies the information signal 616 to the precision timing generator 608. The information signal 616 can be any type of intelligence, including digital bits representing voice, data, imagery, or the like, analog signals, or complex signals.

A pulse generator 622 uses the modulated, coded timing signal 618 as a trigger to generate output pulses. The output pulses are sent to a transmit antenna 624 via a transmission line 626 coupled thereto. The output pulses are converted into propagating electromagnetic pulses by the transmit antenna 624. In the present embodiment, the electromagnetic pulses are called the emitted signal, and propagate to an impulse radio receiver 702, such as shown in Fig. 7, through a propagation medium, such as air, in a radio frequency embodiment. In a preferred embodiment, the emitted signal is wide-band or ultrawide-band, approaching a monocycle pulse as in Fig. 1A. However, the emitted signal can be spectrally modified by filtering of the pulses. This bandpass filtering will cause each monocycle pulse to have more zero crossings (more cycles) in the time domain. In this case, the impulse radio receiver can use a similar waveform as the template signal in the cross correlator for efficient conversion.

## II.2. Receiver

An exemplary embodiment of an impulse radio receiver (hereinafter called the receiver) for the impulse radio communication system is now described with reference to Fig. 7.

The receiver 702 comprises a receive antenna 704 for receiving a propagated impulse radio signal 706. A received signal 708 is input to a cross correlator or sampler 710 via a receiver transmission line, coupled to the receive antenna 704, and producing a baseband output 712.

The receiver 702 also includes a precision timing generator 714, which receives a periodic timing signal 716 from a receiver time base 718. This time base 718 is adjustable and controllable in time, frequency, or phase, as required by the lock loop in order to lock on the received signal 708. The precision timing generator 714 provides synchronizing signals 720 to the code source 722 and receives a code control signal 724 from the code source 722. The precision timing generator 714 utilizes the periodic timing signal 716 and code control signal 724 to produce a coded timing signal 726. The template generator 728 is

triggered by this coded timing signal 726 and produces a train of template signal pulses 730 ideally having waveforms substantially equivalent to each pulse of the received signal 708. The code for receiving a given signal is the same code utilized by the originating transmitter to generate the propagated signal. Thus, the timing of the template pulse train matches the timing of the received signal pulse train, allowing the received signal 708 to be synchronously sampled in the correlator 710. The correlator 710 ideally comprises a multiplier followed by a short term integrator to sum the multiplier product over the pulse interval.

The output of the correlator 710 is coupled to a subcarrier demodulator 732, which demodulates the subcarrier information signal from the subcarrier. The purpose of the optional subcarrier process, when used, is to move the information signal away from DC (zero frequency) to improve immunity to low frequency noise and offsets. The output of the subcarrier demodulator is then filtered or integrated in the pulse summation stage 734. A digital system embodiment is shown in Fig. 7. In this digital system, a sample and hold 736 samples the output 735 of the pulse summation stage 734 synchronously with the completion of the summation of a digital bit or symbol. The output of sample and hold 736 is then compared with a nominal zero (or reference) signal output in a detector stage 738 to determine an output signal 739 representing the digital state of the output voltage of sample and hold 736.

The baseband signal 712 is also input to a lowpass filter 742 (also referred to as lock loop filter 742). A control loop comprising the lowpass filter 742, time base 718, precision timing generator 714, template generator 728, and correlator 710 is used to generate an error signal 744. The error signal 744 provides adjustments to the adjustable time base 718 to time position the periodic timing signal 726 in relation to the position of the received signal 708.

In a transceiver embodiment, substantial economy can be achieved by sharing part or all of several of the functions of the transmitter 602 and receiver 702. Some of these include the time base 718, precision timing generator 714, code source 722, antenna 704, and the like.

FIGS. 8A-8C illustrate the cross correlation process and the correlation function. Fig. 8A shows the waveform of a template signal. Fig. 8B shows the waveform of a received impulse radio signal at a set of several possible time offsets. Fig. 8C represents the output of the correlator (multiplier and short time integrator) for each of the time offsets of Fig. 8B. Thus, this graph does not show a waveform that is a function of time, but rather a function of time-offset. For any given pulse received, there is only one corresponding point which is applicable on this graph. This is the point corresponding to the time offset of the template signal used to receive that pulse. Further examples and details of precision timing can be found described in Patent 5,677,927, and commonly owned co-pending application 09/146,524, filed September 3, 1998, titled "Precision Timing Generator System and Method", both of which are incorporated herein by reference.

### III. Overview of the Invention

The present invention is directed to a system and method for impulse radio power control. Fig. 9 depicts an example communications environment within which the present invention is used. Two or more impulse radio transceivers 902A, 902B communicate with one another, possibly in the presence of an interfering transmitter 908. Each transceiver 902A, 902B includes an impulse radio receiver 702 and an impulse radio transmitter 602. Fig. 9 depicts two transceivers 902A and 902B, separated by a distance  $d_1$ . As shown, transmitter 602A transmits a signal S1 that is received by receiver 702B. Transmitter 602B transmits a signal S2 that is received by receiver 702A. Interfering transmitter 908, if present, transmits an interfering signal S3 that is received by both receiver 702A and receiver 702B. Interfering transmitter 908 is situated a distance  $d_2$  from transceiver 902B.

The output power of transmitters 602A, 602B is adjusted, according to a preferred embodiment of the present invention, based on a performance measurement(s) of the received signals. In one embodiment, the output power

of transmitter 602B is adjusted based on a performance measurement of signal S2 as received by receiver 702A. In an alternative embodiment, the output power of transmitter 602B is adjusted based on a performance measurement of signal S1 received by receiver 702B. In both cases, the output power of transmitter 602B is increased when the performance measurement of the received signal drops below a threshold, and is decreased when the performance measurement rises above a threshold. Several alternative embodiments are described below for calculating this power control update.

Power control refers to the control of the output power of a transmitter. However, it is noted that this is usually implemented as a voltage control proportional to the output signal voltage.

Different measurements of performance can be used as the basis for calculating a power control update. As discussed in detail below, examples of such performance measurements include signal strength, signal-to-noise ratio (SNR), and bit error rate (BER), used either alone or in combination.

For the sake of clarity, Fig. 9 depicts two transceivers 902A, 902B in two-way communication with one another. Those skilled in the art will recognize that the principles discussed herein apply equally well to multiple transceivers 902 in communication with each other. Transceiver 902 can represent any transceiver employing impulse radio technology (for examples, see U.S. Patent No. 5,677,927, incorporated by reference above). Transceiver 902 can be a hand-held unit, or mounted in some fashion, e.g., a transceiver mounted in a base station. For example, referring to Fig. 9, transceiver 902A can represent a hand-held phone communicating a transceiver 902B that is part of a base station. Alternatively, both transceivers 902A and 902B can represent hand-held phones communicating with each other. A plethora of further alternatives are envisioned.

Interfering transmitter 908 includes transmitter 910 that transmits electromagnetic energy in the same or a nearby frequency band as that used by transceivers 902A and 902B, thereby possibly interfering with the communications of transceivers 902A and 902B. Interfering transmitter 908

might also include a receiver, although the receiver function does not impact interference analysis. For example, interfering transmitter 908 could represent an impulse radio communicating with another impulse radio (not shown). Alternatively, interfering transmitter 908 could represent any arbitrary transmitter that transmits electromagnetic energy in some portion of the frequency spectrum used by transceivers 902. Those skilled in the art will recognize that many such transmitters can exist, given the ultra-wideband nature of the signals transmitted by transceivers 902.

For those environments where multiple impulse radios of similar design are operating in close geographic proximity, interference between the impulse radios is minimized by controlling the transmitter power in each transceiver according to the present invention. Consider the example environment depicted in Fig. 9 where interfering transmitter 908 represents an impulse radio transceiver similar in design to transceivers 902A and 902B. Lowering the output power of interfering transmitter 908 reduces the extent to which S3 interferes with the communication between transceivers 902A and 902B. Similarly, lowering the power of transmitters 602A and 602B reduces the extent to which S1 and S2 interfere with the communications of transmitter 908. According to the present invention, each transmitter (602A, 602B, and 910 in those situations where interfering transmitter 908 represents an impulse radio) maintains its output power to achieve a satisfactory signal reception. The present invention is therefore particularly well suited to a crowded impulse radio environment.

#### **IV. Power Control Process**

##### **IV.1. Power Control Overview**

Generally speaking, impulse radio power control methods utilize a performance measurement indicative of the quality of the communications process where the quality is power dependent. This quality measurement is compared with a quality reference in order to determine a power control update.

Various performance measurements can be used, individually or in combination. Each has slightly different characteristics, which can be utilized in different combinations to construct an optimum system for a given application. Specific performance measurements that are discussed below include signal strength, signal to noise ratio (SNR), and bit error rate (BER). These performance measurements are discussed in an idealized embodiment. However, great accuracy is generally not required in the measurement of these values. Thus, signals approximating these quantities can be substituted as equivalent. Other performance measurements related to these or equivalent to these would be apparent to one skilled in the relevant art. Accordingly, the use of other measurements of performance are within the spirit and scope of the present invention.

Fig. 10 illustrates a typical two transceiver system comprising transceiver 902A and transceiver 902B and utilizing power control according to an embodiment of the present invention. Referring to Fig. 10, receiver 702A receives the transmission 1008 from transmitter 602B of transceiver 902B. Signal evaluation function 1011A evaluates the signal quality, and quality measurement(s) 1012A are provided to the power control algorithm 1014A. Power control algorithm 1014A then determines a power control update 1016 according to the current received signal quality measurement(s) 1012A determined by signal evaluation function 1011A. This update 1016 is added to the signal data stream in the transmitter data multiplexer 1018A and then transmitted via transmitter 602A to transceiver 902B. Receiver 702B of transceiver 902B receives a data stream and demultiplexer 1020B separates the user data and power control command 1016, sending the power control command 1016 to transmitter 602B (or to power control function 1126 as discussed below in connection with Fig. 11). Transmitter 602B (or power control function 1126) then adjusts the transmission output level of signal 1008 according to the power control command, which is based on the received signal quality measurement(s) 1012A determined by transceiver 902A. A similar control loop operates to

control transmitter 602A according to the received signal quality measurement(s) 1012B determined by signal evaluation function 1011B of transceiver 902B.

Fig. 11 illustrates a transceiver 902 modified to measure signal strength, SNR, and BER according to an embodiment of the present invention. According to this embodiment, an originating transmitter transmits the RF signal 706, which is received by the antenna 704. The resulting received signal 708 is then provided to the correlator 710 where it is multiplied according to the template signal 730 and then short term integrated (or alternatively sampled) to produce a baseband output 712. This baseband output is provided to the optional subcarrier demodulator 732, which demodulates a subcarrier as applied to the transmitted signal 706. This output is then long term integrated in the pulse summation stage 734, which is typically an integrate and dump stage that produces a ramp shape output waveform when the receiver 702 is receiving a transmitted signal 706, or is typically a random walk type waveform when receiving pure noise. This output 735 (after it is sampled by sample and hold state 736) is fed to a detector 738 having an output 739, which represents the detection of the logic state of the transmitted signal 706.

The output of the correlator 710 is also coupled to a lock loop comprising a lock loop filter 742, an adjustable time base 718, a precision timing generator 714, a template generator 728, and the correlator 710. The lock loop maintains a stable quiescent operating point on the correlation function in the presence of variations in the transmitter time base frequency and variations due to Doppler effects.

The adjustable time base 718 drives the precision timing generator 714, which provides timing to the code generator 722, which in turn, provides timing commands back to the timing generator 714 according to the selected code. The timing generator 714 then provides timing signals to the template generator 728 according to the timing commands, and the template generator 728 generates the proper template waveform 730 for the correlation process. Further examples and



discussion of these processes can be found in the patents incorporated by reference above.

It is noted that coding is optional. Accordingly, it should be appreciated that the present invention covers non-coded implementations that do not  
5 incorporate code source 722.

Referring again to Fig. 11, the output 735 of the pulse summation stage 734 is sampled by the sample and hold stage 736 producing an output 1102 which is then processed by a signal evaluation stage 1011 that determines a measure of the signal strength 1106, received noise 1108, and SNR 1110. These values are  
10 passed to the power control algorithm 1014, which may combine this information with a BER measurement 1112 provided by a BER evaluation function 1116. The power control algorithm 1014 generates a power control update 1016 value according to one or more of the performance measurements. This value is combined with the information signal 616 and sent to the transceiver which is  
15 originating the received signal 706. One method of combining this information is to divide the data stream into time division blocks using a multiplexer 1018. A portion of the data stream 1122 contains user data (i.e., information signal 616) and a portion contains control information, which includes power control update information 1016. The combined data stream 1122 is then provided to the  
20 transmitter precision timing generator 608, which may optionally include a subcarrier modulation process. This timing generator is driven by a transmitter time base 604 and interfaces with a code generator 612, which provides pulse position commands according to a PN code. The timing generator 608 provides timing signals 618 to the pulse generator 622, which generates pulses 626 of  
25 proper amplitude and waveform according to the timing signals 618. These pulses are then transmitted by the antenna 624.

It is noted that BER 1112 is a measure of signal quality that is related to the ratio of error bits to the total number of bits transmitted. The use of other signal quality measurements, which are apparent to one skilled in the relevant art,  
30 are within the spirit and scope of the present invention.

It should be apparent to one of ordinary skill in the art that the system functions such as power command 1124 and power control 1126 can be implemented into either the transmitter 602 or receiver 702 of a transceiver, at the convenience of the designer. For example, power control 1126 is shown as being  
5 part of transmitter 602 in Fig. 10.

The transceiver originating the RF signal 706 has a similar architecture. Thus, the received data stream 739 contains both user data and power control commands, which are intended to control the pulse generator 622. These power control commands are selected from the data stream by a power command  
10 function 1124, which includes the function of receive data demultiplexer 1020, and delivered to a power control function 1126 that controls the output power of the pulse generator 622.

#### **IV.2. Impulse Radio Performance Measurements**

According to the present invention, the output 1102 of the sample and hold stage 736 is evaluated to determine signal performance criteria necessary for  
15 calculation of power control updates 1016. The signal performance criteria can include signal strength, noise, SNR and/or BER.

First, the signal detection process is described in greater detail in accordance with Fig. 12, which describes the workings of the detector 738 of  
20 Figs. 7 and 11. The output 735 of the pulse summation stage 734 is provided to the input of the sample and hold 736, which is clocked by a sample clock signal 1202 at the end of the integration period (pulse summation period) for a data bit. This samples the final voltage level, which represents the integration result, and holds it until the integration of the next data bit is complete. The output 1102 of  
25 this sample and hold 736, is supplied to an averaging function 1204, which determines the average value 1206 of this signal 1102. This average function 1204 may be a running average, a single pole low pass filter, a simple RC filter (a filter including a resistor(s) and capacitor(s)), or any number of equivalent averaging functions as would be known by one of ordinary skill in the art. This

average value 1206 represents the DC (direct current) value of the output 1102 of sample and hold 736 and is used as the reference for comparator 1208 in the determination of the digital value of the instant signal which is output as Received Data 739. The advantage of averaging function 1204 is to eliminate DC offsets in the circuits leading up to sample and hold 736. This function, however, depends on a relatively equal number of ones and zeroes in the data stream. An alternative method is to evaluate the average only when no signal is in lock, as evidenced by low signal strength, and then to hold this value when a signal is in lock. This will be discussed later in detail with reference to Fig. 17. This depends on the assumption that the DC offset will be stable over the period of the transmission. A further alternative is to build low offset circuits such that a fixed value, e.g. zero, may be substituted for the average. This is potentially more expensive, but has no signal dependencies. A fourth alternative is to split the difference between the average voltage detected as a data "one" and the average voltage detected as a data "zero" to determine a reference value for bit comparison. This difference is available from a signal strength measurement process, which is now described in greater detail in the discussion of Fig. 13

#### **IV.2.a. Signal Strength Measurement**

Fig. 13 illustrates the details of the signal evaluation function 1011 of Fig. 11. This function determines signal strength by measuring the difference between the average voltage associated with a digital "one" and the average voltage associated with a digital "zero". Noise is determined by measuring the variation of these signals, and "signal to noise" is determined by finding the ratio between the signal strength and the noise.

The process for finding signal strength will now be described with reference to Fig. 13, which includes two signal paths, each for determining the average characteristics of the output voltage associated with a detected digital "one" or "zero" respectively. The upper path comprising switch 1302, average

function 1304, square function 1306, filter 1308, and square root function 1310 operates when the receive data detects a digital "one." The lower path, comprising switch 1312, average function 1314, square function 1316, filter 1318, and square root function 1320 operates when the receive data detects a digital "zero" according to inverter 1322. It would be appreciated by one skilled in the art that multiple such paths may be implemented corresponding to multiple states of modulation, should such multiple states be implemented in the particular transceiver system. It should also be noted that a single path might be sufficient for many applications, resulting in possible cost savings with potentially some performance degradation.

More specifically, the output 1102 of the sample and hold 736 is fed to either average function 1304 or average function 1314, according to the receive data 739 and inverter 1322, which determines whether the instant signal summation (i.e., the instant of receive data 739) is detected as a "one" or a "zero". If the signal is detected as a digital "one", switch 1302 is closed and average function 1304 receives this signal, while average function 1314 receives no signal and holds its value. If the signal is detected as a digital "zero", switch 1312 is closed and average function 1314 receives this signal, while average function 1304 receives no signal and holds its value.

Average functions 1304 and 1314 determine the average value of their respective inputs over the number of input samples when their respective switch is closed. This is not strictly an averaging over time, but an average over the number of input samples. Thus, if there are more ones than zeroes in a given time interval, the average for the ones would reflect the sum of the voltage values for the ones over that interval divided by the number of ones detected in that interval rather than simply dividing by the length of the interval or number of total samples in the interval. Again this average may be performed by running average, or filter elements modified to be responsive to the number of samples rather than time. Whereas, the average over the number of samples represents the best mode in that it corrects for an imbalance between the number of ones and

zeroes, a simple average over time or filter over time may be adequate for many applications. It should also be noted that a number of averaging functions including, but not limited to, running average, boxcar average, low pass filter, and others can be used or easily adapted to be used in a manner similar to the examples by one of ordinary skill in the art.

It should also be appreciated that a simple average based strictly on digital "ones" or "zeroes", rather than the composite that includes both "ones" and "zeroes", can be evaluated with a slight loss of performance to the degree that the average voltage associated with "ones" or the average voltage associated with "zeros" are not symmetrical.

The outputs of averaging functions 1304 and 1314 are combined to achieve a signal strength measurement 1324. In the embodiment illustrated, the voltage associated with digital "one" is positive, and the voltage associated with digital zero is negative, thus the subtraction indicated in the diagram, is equivalent to a summation of the two absolute values of the voltages. It should also be noted that this summation is equal to twice the average of these two values. A divide by two at this point would be important only in a definitional sense as this factor will be accommodated by the total loop gain in the power control system.

The purpose of square functions 1306 and 1316, filters 1308 and 1318, and square root functions 1310, 1320 shall be described below in the following section relating to noise measurements.

#### **IV.2.b.Noise Measurement**

Fig. 15 and Fig. 13 illustrate a noise measurement process in accordance with an embodiment of the present invention. This noise measurement process is contained within the signal evaluation function 1011 of Fig. 11. The noise measurement is combined with the signal strength measurement to derive a signal to noise measurement 1110. There are two modes that must be considered when determining the noise value.

The first mode is now described with reference to Fig. 15. This mode is used before a signal is in lock. In this situation, the pulse summation function is not generating ramps because there is no coherent signal being received. To measure noise in this mode, the samples from sample and hold 736 are evaluated for statistical standard deviation, i.e. the RMS (root mean square) AC (alternating current) voltage. This value is then averaged by an average function to provide a stable measure of the noise. The averaged value can then be used as an initial value for the noise after a signal is captured and locked.

More specifically, referring to Fig. 15, the output 1102 of sample and hold 736 is averaged in the average function 1204 to remove any DC offset that may be associated with the signal. The output of average function 1204 is then subtracted from the sample and hold output producing a zero mean signal 1502. The zero mean signal 1502 is then squared by square function 1504 and filtered by filter 1506. This result (the output of filter 1506) represents the variance 1512 of the noise. A square root function 1508 is also applied, resulting in the RMS value 1510 of the noise.

Fig. 16 illustrates an alternate processing method which may afford some implementation economies. Referring to Fig. 16, the zero mean signal 1502 is provided to an absolute value function 1602 which is then filtered by filter 1604, resulting in an output 1606 that may be used in place of the RMS value 1510.

The second mode to be considered occurs when the receiver is locked to a received signal. In this mode, the pulse summation function is generating a generally ramp shaped time function signal due to the coherent detection of modulated data "ones" and "zeroes". In this mode the desired noise value measurement is the statistical standard deviation of the voltage associated with either the data "ones" or data "zeros". Alternatively, as discussed below in the description of Fig. 14, the absolute value of the voltage associated with either the data "ones" or data "zeros" can be used in place of standard deviation.

Referring again to Fig. 13, the output of average function 1304 is subtracted from each sample resulting in a value 1326 that is then squared by

square function 1306, and filtered by filter1308. The filtered result is then processed by square root function 1310, resulting in an RMS AC value 1325 representing the noise associated with the "ones". A similar process is performed on the output of average function 1314 by the square function 1316, filter 1318, and square root function 1320, resulting in a value 1328 representing the noise associated with the data "zeroes". These two values 1325 and 1328 are combined resulting in a value 1330 representing the noise in the reception process. If the noise for the "ones" is equal to the noise for the "zeroes", then this method of adding the values results in a sum equivalent to twice the average of the noise value for the "ones".

The noise value 1330 is combined with the signal strength value 1324 in a divide function 1332 to derive a signal-to-noise value 1334 result. As with the signal strength measurement 1324, computational economies may be achieved by using only the result of the data "ones" or data "zeros" processing for the standard deviation computation, or by using average absolute value in the place of standard deviation.

The use of absolute value in place of standard deviation is now described with reference to Fig. 14. Fig 14 illustrates an alternate solution to the square function 1306, filter 1308, and square root function 1310 sequence identified as 1336 in Fig. 13. The output of average function 1304 is subtracted from each sample resulting in a value 1326 that is provided to the absolute value function 1402 and the result is then filtered by filter 1308 to produce an alternative to the RMS value 1325. Other methods of achieving computational efficiency would be apparent to one of ordinary skill in the art.

The terminology data "ones" and data "zeroes" refers to the logic states passed through the impulse radio receiver. In a typical system, however, there may be a Forward Error Correction ( hereinafter called FEC) function that follows the impulse receiver. In such a system, the data "ones" and "zeroes" in the impulse receiver would not be final user data, but instead would be symbol

"ones" and "zeros" which would be input to the FEC function to produce final user data "ones" and "zeros".

5 An output combiner for the two noise measurement modes together with a mode logic method is shown with reference to Fig. 17. In Fig. 17 the output of the noise measurement 1510 from the algorithm of Fig. 15, which is valid for the unlocked case and the output of the noise measurement 1330 from the algorithm of Fig. 13, which is valid for the locked case, are provided to the two alternative inputs of a selector switch 1702. The switch 1702 is controlled by the output of a lock detector 1704, which determines the mode. The selected output is then  
10 supplied to the noise output 1106 of the signal evaluation block 1011 of Fig. 11.

The lock detector 1704 comprises a comparator 1706 connected to the signal strength output 1324 of Fig. 13. A reference value 1708 supplied to the comparator 1706 is a value that is slightly higher than the ambient noise. For an impulse radio, and for digital radios in general, a 10 dB signal to noise ratio is generally required in order to achieve acceptable reception. Thus, it is feasible  
15 to place a threshold (that is, the reference value 1708) between the no-signal and the acceptable-signal level.

In a simple receiver, the reference value 1708 may be fixed. In a more advanced radio, the reference value 1708 may be determined by placing the receiver in a state where lock is not possible due to, for instance, a frequency  
20 offset, and then setting the reference value 1708 such that the lock detector 1704 shows a stable unlocked state. In another embodiment, the reference value 1708 is set to a factor (e.g., two) times the unlocked noise value 1510.

In the embodiment of Fig. 17, the output of lock detector 1704 is also shown switching (enabling) the outputs of the signal strength 1324 and signal to  
25 noise 1334 signals using switches 1712 and 1714, since these outputs are not meaningful until a significant signal is received and in lock. These outputs 1324, 1334 are then supplied to the outputs 1108, 1110 of the signal evaluation function 1011 of Fig. 11.



#### IV.2.c. Bit Error Rate (BER)

Referring again to Fig. 11, the Bit Error Rate (BER) is measured directly from the received data stream 739. The result 1112 is provided to the power control algorithm 1014. BER can be measured by a number of methods depending on the configuration of the system. In an embodiment adaptable for a block oriented data transmission system, BER is measured periodically, by sending a known bit pattern and determining the number of bits in error. For example, a known one-thousand bit message could be sent ten times a second, and the result examined for errors. The error rate could be directly calculated as the number of errors divided by the total bits sent. This block of known BER pattern data may be broken into sub-blocks and sent as part of the data contained in block or packet headers. Both of these methods require considerable overhead in the form of known data sent on the link in order to calculate the error rate.

In a system adapted to use forward error correction (FEC), the error correction rate can be used as the raw BER measurement representative of signal quality. Suitable algorithms including Reed Soloman, Viterbi, and other convolutional codes, or generally any FEC method that yields an error correction rate can be used.

In a preferred embodiment, parity or check sums are used as a measure of errors, even though they alone are insufficient to correct errors. With this method, the user data is used to measure the error rate and a very small overhead of one percent or less is required for the parity to detect normal error rates. For example, one parity bit added to each block of 128 data bits could measure error rates to  $10^{-2}$ , which would be sufficient to control to a BER of  $10^{-3}$ . Although double bit errors within a block will go unnoticed, this is not of much consequence since the average of many blocks is the value used in the power control loop.

#### IV.2.d. Performance Measurement Summary

In the preferred embodiment, the signal strength measurement 1324 could be fairly responsive, i.e. have very little averaging or filtering, in fact it may have

no filtering and depend on the power control loop or algorithm 1014 to provide the necessary filtering. The signal to noise measurement 1334 also could be fairly responsive to power changes because the signal measurement is simply propagated through the signal to noise divide operation 1332. The noise measurement 1330, however, typically needs significant filtering 1308 to provide a stable base for the divide operation 1332. Otherwise, the SNR value 1334 will vary wildly due to fluctuations in the noise measurement 1330.

The evaluation of BER 1116 requires a large quantity of data in order to achieve a statistically significant result. For example, if a maximum of  $10^{-3}$  BER is desired (e.g., in Fig. 22 discussed below, BER reference 2210 =  $10^{-3}$ ), 1000 data bits must be received to have a likely chance of a single error. 30,000 to 100,000 bits are needed to have a smooth statistical measure at this error rate. Thus, the averaging requirements for BER 1116 are much longer than for signal strength 1324 or SNR 1334, yet BER 1116 is typically the most meaningful measure of channel quality.

It should be apparent to one of ordinary skill in the art that, where some of the diagrams and description may seem to describe an analog implementation, both an analog or a digital implementation are intended. Indeed, the digital implementation, where the functions such as switches, filters, comparators, and gain constants are performed by digital computation is a preferred embodiment.

### IV.3. Impulse Radio Power Control

Fig. 18 is a flowchart that describes a method of power control according to the present invention. Fig. 18 is described with reference to the example environment depicted Figs. 9 and 10. In step 1802, transceiver 902A transmits a signal S1. In step 1804, transceiver 902B receives signal S1. In step 1806, a power control update 1016 is calculated according to a performance measurement(s) of received signal S1. Various performance measurements are discussed below, such as received signal strength, BER, and SNR, can be used either alone or in combination.

In steps 1808A and 1808B, the output power of either transmitter 602A of transceiver 902A or transmitter 602B of transceiver 902B (or both) is controlled according to the power control update 1016. In step 1808A, the power of transmitter 602A of transceiver 902A is controlled according to the power control update 1016, which is preferably calculated (in step 1806) at transceiver 902B and transmitted from transceiver 902B to 902A. Step 1808A is described in additional detail in Fig. 19.

Referring to Fig. 19, transceiver 902B transmits a power control update, in step 1902. In step 1904, transceiver 902A receives the power control update from transceiver 902B. Then, in step 1906, transceiver 902A adjusts its output power (of transmitter 602A) according to the received power control update 1016. According to this embodiment, the power control for a particular transceiver is therefore determined by the performance (measured by another transceiver receiving the signals) of signals it transmits.

Alternatively, in step 1808B, the output power of transmitter 602B of transceiver 902B is controlled according to the power control update 1016. According to this embodiment, the power control for a particular transceiver is therefore determined by the performance of signals it receives from another transceiver. This embodiment assumes that the propagation path between transceivers in communication is bilaterally symmetric, i.e., that signals transmitted between the pair of transceivers undergo the same path loss in both directions. Consider the example environment depicted in Fig. 9. The propagation path between transceivers 902A and 902B is bilateral symmetric if signal S1 undergoes the same path loss as signal S2. The path loss of S1 therefore provides an accurate estimate of the path loss of S2 to the extent that the propagation path approaches bilateral symmetry. According to this embodiment, the power control of transceiver 902B is determined by the performance of received signal S1 (which is transmitted by transceiver 902A and received by transceiver 902B) in lieu of evaluating received signal S2 (which is transmitted by transceiver 902B and received by transceiver 902A). Impulse radio provides

a unique capability for implementing this kind of system. In an impulse radio, the multipath signals are delayed from the direct path signal. Thus the first received pulse in a multipath group will be the direct path signal. If both transceivers in a transceiver system are configured to find and lock on the earliest signal in a multipath group, then the symmetry will be assured, assuming the direct path exists. If the direct path does not exist because of obstruction, then both transceivers will still likely lock on the same early multipath reflection – resulting in a bilateral symmetric propagation configuration.

The following two sections describe steps 1806 and 1808 in greater detail.

#### 10 **IV.3.a. Calculate Power Control Update**

As described above, in step 1806 a power control update is calculated according to a performance measurement(s) of received signal S1. Those skilled in the art will recognize that many different measurements of performance are possible. Several performance measurements are discussed herein, along with their relative advantages and disadvantages.

##### **IV.3.a.i. Using Signal Strength Measurements**

In a first embodiment, the signal strength of the received signal is used as a performance measurement. The power control update, dP, is given by:

$$dP = K(P_{ref} - P_{S1})$$

20 where K is a gain constant;  
 $P_{S1}$  is the signal strength of received signal S1;  
 $P_{ref}$  is a signal strength reference; and  
 dP is the power control update (which is preferable in the unit of Volts).

The output level of transmitter 602A (of transceiver 902A) is therefore increased when  $P_{S1}$  falls below  $P_{ref}$ , and decreased when  $P_{S1}$  rises above  $P_{ref}$ . The

magnitude of the update is linearly proportional to the difference between these two signals. Note that the power control update can be equivalently expressed as an absolute rather than a differential value. This can be achieved by accumulating the differential values  $dP$  and communicating the resulting output level  $P$  as follows:

$$P_n = P_{n-1} + dP,$$

Where  $P_n$  is the output level (e.g., voltage level or power level) to be transmitted during the next evaluation interval;

$P_{n-1}$  is the output level transmitted during the last evaluation interval; and  $dP$  is the output level increment computed as a result of the signal evaluation during the last interval.

Note also that the power control update could be quantized to two or more levels.

A control loop diagram illustrating this embodiment will now be described with reference to Fig. 20. A signal 2002 (e.g., signal 2002 is transmitted by transmitter 602A of transceiver 902A) having a transmitted output level is disturbed by the propagation path according to a disturbance 2004. This disturbance 2004 may be modeled as either an additive process or a multiplicative process. The multiplicative process is generally more representative of the attenuation process for large disturbances 2004. The resulting received signal 2006 (received by receiver 702B or transceiver 902B) is evaluated for signal strength 2008 ( $P_{s,i}$ ) and compared with the desired signal strength reference 2010 ( $P_{ref}$ ). The result is then scaled by  $K$ , 2012 ( $K$ ) to produce power control update 2013 ( $dP$ ). Power control update 2013 ( $dP$ ) is summed or integrated or possibly filtered over time by, for example, integrator 2014 to produce a power control command signal 2016 to command the power control function 2018 (1126 in Fig. 11) of the transmitter (transmitter 602A of transceiver 902A if the embodiment

including step 1808A is implemented, or transmitter 602B of transceiver 902B if the embodiment including step 1808B is implemented) to output a signal 2002 having a new output level (e.g., voltage level or power level). Note that this diagram ignores a nominal path loss and receiver gain which may overcome this path loss. This diagram focuses on the disturbance from the nominal.

If the receiver contains an automatic gain control (AGC), the operation of this AGC must be taken into account in the measurement of signal strength. Indeed, some AGC control signals are suitable for use as a signal strength indicator.

Where the embodiment of 1808B is implemented, the integrating step 2014 should preferably be a filter rather than a perfect integrator and the gain  $K_1$  should be low such that the gain correction is less than sufficient to fully level the power, preferably less than half of what would level the power. This will prevent instability in the system. Such low gain  $K_1$  would likely be discarded as unworkable in conventional spread spectrum systems, but because of the potentially very high processing gain available in an impulse radio systems, and impulse radio system can tolerate gain control errors of much greater magnitude than conventional spread spectrum systems, making this method potentially viable for such impulse radio systems.

It should be apparent to one skilled in the art that the system functions including the reference 2010, the  $K_1$  scaling function 2012, and the integrator 2014, can be partitioned into either the transmitter or receiver at the convenience of the designer.

Those skilled in the art will recognize that many different formulations are possible for calculating a power control update according to received signal strength. For instance, the performance measurement might be compared against one or more threshold values. For example, if one threshold value is used the output power is increased if the measurement falls below the threshold and decreased if the measurement rise above the threshold. Alternatively, for example, the performance measurement is compared against two threshold

values, where output power is increased if the measurement falls below a low threshold, decreased if the measurement rises above a high threshold, or held steady if between the two thresholds. This alternative method is often referred to as being based on hysteresis.

5           These two thresholding methods could also be used with the remaining performance measurements discussed below.

          In another embodiment, transceiver 902A does not evaluate the signal. Transceiver 902B evaluates the signal strength of S1 and computes a power control update command for transmitter 602B and for transmitter 602A. The  
10           power control update (dP) command for transmitter 602A is sent to transceiver 902A and used to control transmitter 602A.

#### IV.3.a.ii. Using SNR Measurements

          In a second embodiment, the SNR of the received signal is used as a performance measurement. The power control update, dP, is given by:

15           
$$dP = K(SNR_{ref} - SNR_{S1})$$

          where K is a gain constant;

          SNR<sub>S1</sub> is the signal-to-noise ratio of received signal S1; and

          SNR<sub>ref</sub> is a signal-to-noise ratio reference.

          The power of transmitter 602A (of transceiver 902A) is therefore  
20           increased when SNR<sub>S1</sub> falls below SNR<sub>ref</sub>, and decreased when SNR<sub>S1</sub> rises above SNR<sub>ref</sub>. The magnitude of the update is linearly proportional to the difference between these two signals. Note that the power control update can be equivalently expressed as an absolute rather than a differential value. As described above, those skilled in the art will recognize that many alternative  
25           equivalent formulations are possible for calculating a power control update according to received signal SNR.

A control loop diagram illustrating the functionality of this embodiment will now be described with reference to Fig. 21. A signal 2002 (e.g. signal 2002 is transmitted by transmitter 602A of transceiver 902A) having a transmitted power level is disturbed by the propagation path according to a disturbance 2004. This disturbance 2004 may be modeled as either an additive process or a multiplicative process; however, the multiplicative process is generally more representative of the attenuation process for large disturbances 2004. The resulting signal 2006 is then combined with additive noise 2102 representing thermal and interference effects to yield a combined signal 2104 which is received by the receiver (receiver 702B of transceiver 902B), where signal strength 2008 and noise 2106 are measured. These values are combined 2108 to yield a signal to noise measurement 2110 ( $SNR_{SI}$ ). The signal to noise measurement 2110 is then compared with a signal to noise reference value 2112 ( $SNR_{ref}$ ). The result is then scaled by  $K_1$  2012 ( $K$ ) to produce power control update 2013 ( $dP$ ). Power control update ( $dP$ ) is summed or integrated 2014 over time to produce a power control command signal 2016 to command the power control function 2018 (1126 in Fig. 11) of the transmitter (transmitter 602A of transceiver 902A if the embodiment including step 1808A is implemented, or transmitter 602B of transceiver 902B if the embodiment including step 1808B is implemented) to output a signal 2002 having a new power level.

Again, it should be apparent to one skilled in the art that the system functions including the reference 2010, the  $K_1$  scaling function 2012, and the integrator 2014, as well as part of the signal evaluation calculations, can be partitioned into either the transmitter or receiver at the convenience of the designer.



#### IV.3.a.iii. Using BER Measurements

In a third embodiment, the BER of the received signal is used as a performance measurement. The power control update,  $dP$ , is given by:

$$dP = K(BER_{S1} - BER_{ref})$$

5

where  $K$  is a gain constant;

$BER_{S1}$  is the bit error rate of received signal  $S1$ ; and

$BER_{ref}$  is a bit error rate reference.

Note that the sign is reversed in this case because the performance indicator, BER is reverse sensed, i.e. a high BER implies a weak signal. The power of transmitter 602A (of transceiver 902A) is therefore decreased when  $BER_{S1}$  falls below  $BER_{ref}$ , and increased when  $BER_{S1}$  rises above  $BER_{ref}$ . The magnitude of the update is linearly proportional to the difference between these two signals. Note that the power control update can be equivalently expressed as an absolute rather than a differential value. As described above, many alternative formulations are possible for calculating a power control update according to received signal BER.

15

20

Note that BER measurements span a large dynamic range, e.g., from  $10^{-6}$  to  $10^{-1}$ , even where the received signal power may vary by only a few dB. BER measurements are therefore preferably compressed to avoid the wide variation in control loop responsiveness that would otherwise occur. One method of compressing the range is given by:

$$dP = K(\log(BER_{S1}) - \log(BER_{ref})),$$

25

Where  $\log()$  is the logarithm function and the other variables are defined above.

Thus five orders of dynamic range are compressed into the range from -1 to -6, which makes the control loop stability manageable for typical systems. An alternative compression function can be generated by mapping BER into equivalent dB gain for a given system. This function can be based on theoretical white Gaussian noise, or can be based on measurements of environmental noise for a given system.

Using BER as the measure of performance provides meaningful power control in digital systems. However, calculating BER requires a relatively long time to develop reliable statistics. SNR is not as meaningful as BER, but may be determined more quickly. Signal strength is less meaningful still because it does not account for the effects of noise and interference, but may be determined with only a single sample. Those skilled in the art will recognize that one would use these performance measurements to trade accuracy for speed, and that the particular environment in which the transceivers will be used can help determine which measurement is the most appropriate. For example, received signal variations in a mobile application due to attenuation and multipath signals demand high update rates, whereas high noise environments tend to need more filtering to prevent erratic behavior.

Combining BER, SNR, and/or signal strength can produce other useful performance measurements.

#### IV.3.a.iii.(1) BER and Signal Strength

In a fourth embodiment, BER and signal strength are combined to form a performance measurement, where the power control update,  $dP$ , is given by:

$$P_{ref} = K_2(\log(BER_{S1}) - \log(BER_{ref}))$$

$$dP = K_1(P_{ref} - P_{S1})$$

where  $K_1$  and  $K_2$  are gain constants;

$BER_{S1}$  is the bit error rate of received signal S1;

BER<sub>ref</sub> is a bit error rate reference; and  
 P<sub>S1</sub> is the signal strength of received signal S1.

5 P<sub>ref</sub>, a signal strength reference, is calculated according to the first formula and substituted into the second to determine the power control update. This composite performance measurement combines the more accurate BER measurement with the more responsive signal strength measurement. Note that the power control update might be equivalently expressed as an absolute rather than a differential value.

#### 10 IV.3.a.iii.(2) BER and SNR

In a fifth embodiment and a sixth embodiment, BER and SNR are combined to form a performance measurement. In the fifth embodiment, the power control update, dP, is given by:

$$15 \quad \begin{aligned} SNR_{ref} &= K_2(BER_{S1} - BER_{ref}) \\ dP &= K_1(SNR_{ref} - SNR_{S1}) \end{aligned}$$

where K<sub>1</sub> and K<sub>2</sub> are gain constants;  
 BER<sub>S1</sub> is the bit error rate of received signal S1;  
 BER<sub>ref</sub> is a bit error rate reference; and  
 SNR<sub>S1</sub> is the signal-to-noise ratio of received signal S1.

20 In the sixth embodiment, the power control update, dP, is given by:

$$\begin{aligned} SNR_{ref} &= K_2(\log(BER_{S1}) - \log(BER_{ref})) \\ dP &= K_1(SNR_{ref} - SNR_{S1}) \end{aligned}$$

where K<sub>1</sub> and K<sub>2</sub> are gain constants;

$BER_{S1}$  is the bit error rate of received signal S1;  
 $BER_{ref}$  is a bit error rate reference; and  
 $SNR_{S1}$  is the signal-to-noise ratio of received signal S1.

$SNR_{ref}$ , a signal-to-noise ratio reference, is calculated according to the first  
5 formula and substituted into the second to determine the power control update.  
This composite performance measurement combines the more accurate BER  
measurement with the more responsive SNR measurement. Note that the power  
control update might be equivalently expressed as an absolute rather than a  
differential value.

10 A control loop simulation diagram illustrating the functionality of an  
embodiment based on BER and SNR will now be described with reference to Fig.  
22. A signal 2002 (e.g., signal 2002 is transmitted by transmitter 602A of  
transceiver 902A) having transmitted power level is disturbed by the propagation  
path according to a disturbance 2202, which may include both propagation and  
15 noise effects as in Fig. 21 yielding a combined signal 2104 which is received by  
the receiver (receiver 702B of transceiver 902B). This signal 2104 is evaluated  
for signal to noise ratio 2204 (combined functions of 2008, 2106 and 2108) and  
then compared with a reference 2206 to yield a result 2210. This result 2210  
is then scaled by scaling function  $K_1$  2012 ( $K_1$ ) and summed or integrated over time  
20 by integrator 2014 to produce a power control command signal 2016 to command  
the power control function 2018 (1126 in Fig. 11) of the transmitter (transmitter  
602A of transceiver 902A if the embodiment including step 1808A is  
implemented, or transmitter 602B of transceiver 902B if the embodiment  
including step 1808B is implemented) to output a signal 2002 having a new  
25 power level. The embodiment including step 1808A is preferred, because the  
embodiment including step 1808B is susceptible to errors from non-symmetrical  
noise and interference as in the case where interfering transmitter 910 is closer  
to receiver 702B than to receiver 702A. The embodiment including step 1808B

may be used in applications that do not need precise power control by using low gain factors ( $K_1$  and  $K_2$ ).

Reference 2206 is based on BER measurement 2208 ( $BER_{S1}$ ) of signal 2104. More specifically, signal 2104 is evaluated for BER 2208 and then compared to desired BER reference 2209 ( $BER_{ref}$ ). The result is then scaled by  $K_2$  2212 and filtered or integrated over time by integrator 2214 to produce reference 2206 ( $SNR_{ref}$ ). This process results in the SNR reference 2206 used by the SNR power control loop. The BER path is adjusted by scaling function  $K_2$  2212 ( $K_2$ ) and by the bandwidth of the filter 2214 (when a filter is used for this function) to be a more slowly responding path than the SNR loop for loop dynamic stability reasons and because BER requires a much longer time to achieve a statistically smooth and steady result. Note also that to implement the integrator 2214 as a pure integrator rather than a filter the equations may be modified to include an additional summation stage:

$$\begin{aligned}
 dSNR_{ref} &= K_1(\log(BER_{S1}) - \log(BER_{ref})) \\
 SNR_{ref} &= dSNR_{ref} + SNR_{ref} \\
 dP &= K_2(SNR_{ref} - SNR_{S1})
 \end{aligned}$$

where  $K_1$  and  $K_2$  are gain constants;  
 $BER_{S1}$  is the bit error rate of received signal S1;  
 $BER_{ref}$  is a bit error rate reference;  
 $dSNR_{ref}$  is an incremental change in SNRref ;  
 $SNR_{ref}$  is a calculated reference used in the SNR loop; and  
 $SNR_{S1}$  is the signal-to-noise ratio of received signal S1.

Again, it should be apparent to one skilled in the art that the system functions illustrated on Fig. 22 from the references 2206 and 2209 to the integrator 2014 as well as part of the signal evaluation calculations 2204 and

2208, can be partitioned into either the transmitter or receiver at the convenience of the designer.

A control loop simulation diagram illustrating the addition of the  $\log(\text{BER})$  function will now be described with reference to Fig. 23. It can be seen that this Figure is substantially similar to Fig. 22 except that the BER measurement 2208 is processed by a log function 2302 ( $\log(\text{BER}_{SI})$ ) and compared with a reference 2304 ( $\log(\text{BER}_{ref})$ ) suitable for the  $\log(\text{BER})$  value before being scaled by scaling function  $K_2$  2212 ( $K_2$ ) and integrated or filtered by integrator 2214 and used as the reference 2206 ( $\text{SNR}_{ref}$ ) for the SNR control loop.

One should note that strong signals result in small BER measurement values or large magnitude negative  $\log(\text{BER})$  values and that control loop gain factor polarities need to be adjusted to account for this characteristic.

#### **IV.3.b. Calculate Power Control Update Using Measurements of a Signal Transmitted by another Transceiver**

In each of the above discussed embodiments for performing power control, power control for a particular transceiver (e.g., transceiver 902A) can be determined based on the performance (i.e., signal strength, SNR and/or BER) of signals transmitted by the particular transceiver and received by another transceiver (e.g., transceiver 902B), as specified in step 1808A of Fig. 18. More specifically, in step 1808A, the power of transmitter 602A of transceiver 902A is controlled according to a power control update, which is preferably calculated at transceiver 902B and transmitted from transceiver 902B to transceiver 902A.

Alternatively, as briefly discussed above, each of the above discussed embodiments for performing power control for a particular transceiver can be determined based on the performance (i.e., signal strength, SNR and/or BER), of signals it receives, as in step 1808B of Fig. 18. More specifically, according to this embodiment, the power control for a particular transceiver (e.g., transceiver 902A) is determined by the performance of signals it receives from another transceiver (e.g., signals transmitted from transceiver 902B and received by transceiver 902A).

This power control embodiment assumes that the propagation path between transceivers in communication is bilaterally symmetric. However, an interfering transmitter (e.g., transmitter 908), when present, will disturb the system asymmetrically when it is nearer to one transceiver. As shown in Fig. 9, interfering transmitter 908 is nearer to transceiver 902B. Thus, when interfering transmitter 908 turns on, the noise level at transceiver 902B will increase more than the noise level at transceiver 902A. The response of the power control system can vary depending on the performance measurement utilized. If the power control system is using signal strength, the control system would be unaffected by the interference, but if the system is using signal to noise ratio, the nearby transceiver 902B would increase power to overcome the performance degradation. In this case, it is an unnecessary increase in power. This increase in power would be seen as a propagation improvement at transceiver 902A, which would decrease power, resulting in an even lower SNR at 902B, which would increase power further. Clearly this is not workable.

In a preferred embodiment, this can be overcome by communicating to transceiver 902B the power (e.g., relative power or absolute power) transmitted by transceiver 902A. This allows transceiver 902B to separate power changes due to power control from changes due to propagation. This communication can be accomplished according to conventional techniques, such as transmitting a digital message in a link control header, or transmitting a periodic power reference. With this information, transceiver 902B may adjust its power based only on propagation changes and not on power control adjustments made by transceiver 902A.

Multi-path environments can also disturb system symmetry. A transceiver 902 can lock onto various multi-path signals as the transceivers in communication move in relation to one another. If the two transceivers are not locked on to signals from the same path, the signals will not necessarily match in attenuation patterns. This can cause erroneous power control actions in the affected transceiver 902.

A more general block diagram of a transceiver power control system including power control of both transmitters (i.e., transmitter 602A of transceiver 902A and transmitter 602B of transceiver 902B) from signal evaluations from both transceivers (i.e., transceivers 902A and 902B) is shown in Fig. 24. For this discussion, auto-power control refers to power control of a first transceiver's (e.g., transceiver 902A) output according to the evaluation of a signal transmitted by a second transceiver (e.g., transceiver 902B) and received by the first transceiver (e.g., transceiver 902A). Thus, auto power control relates to step 1808B discussed above. Cross power control refers to the control of a first transceiver's (e.g., transceiver 902A) output according to the evaluation of the first transceiver's transmitted signal as received at a second transceiver (e.g., transceiver 902B). Thus cross power control relates to step 1808A discussed above.

Referring to Fig. 24, transmitter 602A transmits a signal 2402 to receiver 702B of transceiver 902B. This signal 2402 is evaluated by signal evaluation function 1011B resulting in performance measurement(s) 1012B (e.g., signal strength, SNR and/or BER) which are delivered to the power control algorithm 1014B. The power control algorithm 1014B also receives power control messages 2404 from transmitter 602A via the receiver data demultiplexer 1020B, which separates user data and power control messages 2404. These power control update messages 2404 can comprise data related to the power level of transmitter 602A and/or signal evaluations (e.g., signal strength, SNR, and/or BER) of signals 1008 received by receiver 702A (i.e., signals transmitted by transceiver 902B and received by transceiver 902A).

The power control algorithm 1014B then computes a new power level 2406B to be transmitted and delivers this value to transmitter 602B. Power control algorithm 1014B can also deliver signal evaluations 2408, which are based on measurements determined by signal evaluation function 1011B, to the TX data multiplexer 1018B. Alternatively, signal evaluation function 1011B can deliver this information 2408 directly to TX data multiplexer 1018B. This signal



evaluation data 2408 is then added to the input data stream and transmitted at the commanded power level 2406B.

Fig. 25 illustrates an embodiment of the power control algorithm 1014B (of transceiver 902B) employing auto-control with power level messaging. Referring to Fig. 25, the received signal (transmitted by transmitter 702A and received by receiver 602B) is evaluated for signal strength 1106B by signal evaluation function 1011B. Additionally, receive data demultiplexer 1020B (See Fig. 24) separates user data and power control messages 2404 and delivers the power control messages 2404 to subtract function 2502B. The power control message value 2404 (representing the output level of transmitter 602A) is then subtracted by subtractor 2502 from the signal strength measurement 1106 (which is based on the strength of a signal transmitted by transceiver 902A). The result 2406 is used to deviate (e.g., decrease or increase) the transmitter output from a nominal output level. Additionally, a message value that represents the transmitted output level is generated and sent to the other transceiver 902A.

Thus, it can be seen that if the signal becomes attenuated, the output of the subtractor 2504 will decrease, resulting in an increase in the transmitted output level (e.g., voltage level or output level) and a message to that effect. On the other hand if transmitter 602A decreases its output level due to a measured signal condition, both the received signal and output level signals will decrease such that there is no change in the difference resulting in no change to the output power. This mechanism prevents a runaway positive feedback loop between the two transceivers and allows higher control loop gains than would be workable without the message.

Fig. 26 illustrates an embodiment where auto and cross control are implemented in combination. Referring to Fig. 26, the received signal is evaluated by signal evaluation function 1011B for signal strength 1106B and SNR 1110B. The output level signal 2404 (representing the output level of transmitter 602A) is subtracted from the signal strength 1106B resulting in an auto control signal 2406. This auto control signal 2406 is combined with a signal

strength 1106A or SNR measurement 1110A determined by the signal evaluation function 1011A of the other transceiver 902A and further filtered by combiner/filer 2602 to produce an output level value 2604 used to control the output level of transmitter 602B. This output level value 2604 is combined with the signal strength 1106B and SNR 1110B measurements by multiplexer 2606, and then further combined with the transmitted data stream by transmit data multiplexer 1018B. This system takes full advantage of both the auto and cross power control methods, with the auto power control generally offering speed of response, and the cross power control offering precision together with tolerance of link imbalance and asymmetry.

In a preferred embodiment, the power control update is calculated at the transceiver receiving the signals upon which the update is based. Alternatively, the data required to calculate the power control update may be transmitted to another transceiver and calculated there.

#### IV.4. Transceiver Power Control

Returning to Fig. 18, in steps 1808A and 1808B, the output power of either transceiver 902A or 902B (or both) is controlled according to the power control update calculated in step 1806.

In step 1808A, the power of transmitter 602A of transceiver 902A is controlled according to the power control update. Fig. 19, briefly discussed above, is a flowchart that depicts step 1808A in greater detail according to a preferred embodiment. In step 1902, transceiver 902B transmits the power control update calculated in step 1806 (assuming that, according to a preferred embodiment, the power control update is calculated at transceiver 902B). In step 1904, transceiver 902A receives the power control update. In step 1906, transceiver 902A adjusts its output level (e.g., voltage level or power level) according to the received power control update, as described in detail below.

Alternatively, in step 1808B, the power of transmitter 602B of transceiver 902B is controlled according to the power control update. Thus here, the power

level of the signal S1 (sent by transceiver 902A and received by transceiver 902B) is used to control the output level of transmitter 602B. As a result, there is no requirement that the update be transmitted between transceiver 902A and 902B. Rather, transceiver 902B preferably calculates the power control update and adjusts the power of its transmitter 602B accordingly.

Again, it is noted that while power control refers to the control of the output power of a transmitter, this is usually implemented as a voltage control proportional to the output signal voltage.

#### IV.4.a. Integration Gain Power Control

In both steps 1808A and 1808B, power control of a transmitter 902 can be accomplished by controlling any parameter that affects power. In a first embodiment, the pulse peak power (e.g., the height of pulses) of the transmitted signal is controlled while keeping the timing parameters constant. For example, Fig. 27 shows two signals 2702 and 2704 having different pulse peak powers but the same timing parameters. Note that signal 2702 has a greater pulse height and thus corresponds to a greater transmitter power than signal 2704.

In a preferred embodiment, however, the number of pulses per bit is controlled, thereby controlling the integration gain while keeping pulse peak power constant. Integration gain relates to (e.g., is proportional to) the number of pulses summed or integrated in the receiver for each data bit. For a constant data rate, the transmitted power is directly proportional to the number of pulses per bit transmitted. Referring to Fig. 11, in one embodiment where power control commands (e.g., differential commands) are selected from the data stream by a power command function 1124 (which includes the function of receive data demultiplexer 1020) and delivered to a power control function 1126 (that controls the output power of the pulse generator 622), the number of pulses may be found by first, summing the differential commands, and then computing the number of pulses based on this summation, as in the following:

$$P_n = P_{n-1} + dP$$

$$N_{train} = K_p P_n$$

Where,  $P_n$  is the present commanded output level (e.g., voltage level or power level);

5  $P_{n-1}$  is the output level transmitted during the just completed evaluation interval;

$dP$  is the output level increment commanded (also referred to as the power update command 1016) as a result of the just completed evaluation interval;

10  $N_{train}$  is the number of pulses per data bit (also referred to as the number of pulses in a pulse train) to be transmitted during the present evaluation interval; and

$K_p$  is a constant relating power to number of pulses per bit.

Note that a check for limits is necessary.  $N_{train}$  cannot be greater than full power, nor can  $N_{train}$  be less than one. In some cases,  $N_{train}$  must be an even integer or some other quantized level.

In a system with a subcarrier as disclosed in the 5,677,927 patent, it may be preferable to increment pulses according to complete subcarrier cycles in order to keep the subcarrier signal balanced. This can be accomplished by adjusting subcarrier cycle length or by adjusting the number of subcarrier cycles. This can be illustrated by example.

For the example shown in Fig. 28, type A pulses 2802 shall be defined as pulses delayed from nominal by  $\frac{1}{2}$  modulation time and type B pulses 2804 shall be defined as pulses advanced from nominal by  $\frac{1}{2}$  modulation time. Thus, the difference between type A pulses 2802 and type B pulses 2804 is one full modulation time. Using this nomenclature, with reference to an example system with 128 pulses per data bit (i.e.,  $N_{train} = 128$  pulses/bit), a suitable subcarrier might comprise eight periods 2806 (i.e.,  $N_{period} = 8$ ) of 16 pulses (i.e.,  $N_{pulses-per-period} = 16$  pulses/period) where each period 2806 comprises eight type A pulses 2802

followed by eight type B pulses 2804 when a data "one" is transmitted. Power can be reduced by adjusting the subcarrier cycle length by, for example, changing to eight periods 2808 of 14 pulses each (i.e.,  $N_{\text{pulses-per-period}}$  is reduced from 16 pulses/period to 14 pulses/period), where each period 2808 comprises seven type  
5 A pulses 2802 followed by seven type B pulses 2804 and two empty pulses 2810. This maintains the balance of pulse types (same number of each type) within each subcarrier cycle, and thus, the whole data bit interval results in a total of 112 pulses per data bit (i.e.,  $N_{\text{train}}$  is reduced from 128 pulses/bit to 112 pulse/bit) excluding empty pulses 2810. It is noted that the location of the empty pulses can  
10 be changed. For example, each period 2808 can comprise seven type A pulses 2802, followed by one empty pulse 2810, followed by seven type B pulses 2804, followed by one empty pulse 2810.

Alternatively, the power may be reduced by reducing the number of subcarrier cycles. According to this embodiment, to reduce power the example  
15 system could transmit seven (instead of eight) periods of 16 pulses (i.e.  $N_{\text{period}}$  is reduced from 8 periods to 7 periods), where each period comprises eight type A pulses followed by eight type B pulses when a data "one" is transmitted. This would result in a total of 112 pulses per data bit, as opposed to 128 pulses per data bit (i.e.,  $N_{\text{train}}$  is reduced from 128 pulses/bit to 112 pulses/bit). For example,  
20 referring to Fig. 28, to reduce power, a subcarrier cycle can be reduced from eight periods 2806 of 16 pulses to seven periods 2806 of 16 pulses.

Whereas the balance of subcarrier cycles is preferred, it is not required. Patterns may be generated that balance the pulse types over the data bit, wherein one or more subcarrier periods may be unbalanced. Some systems may even  
25 tolerate an unbalance of pulse types over a data bit, but this will usually come with some performance degradation. Other patterns can be easily implemented by one of ordinary skill in the art following the principles outlined in these examples.

The receiver integration gain should ideally track the number of pulses  
30 transmitted. If these values are not coordinated, loss of performance may result.

For example, if the receiver is receiving 128 pulses for each data bit and the transmitter is only transmitting the first 64 of these pulses, the receiver will be adding noise without signal for the second half of the integration time. This will result in a loss of receiver performance and will result in more power transmitted than necessary. This can be prevented by coordinating the number of pulses between the transmitter and receiver. In one embodiment, this information is placed in the headers or other control signals transmitted so that the receiver can determine exactly how many pulses are being sent.

In another embodiment, the receiver employs multiple parallel bit summation evaluations, each for a different possible integration gain pulse configuration. The SNR is evaluated for each summation evaluation path, and the path with the best SNR is selected for data reception. In this way, the receiver can adaptively detect which pulse pattern is being transmitted and adjust accordingly.

#### IV.4.b. Gain Expansion Power Control

Power control can be improved by expanding the gain control sensitivity at high levels relative to low levels. For illustration, an unexpanded gain control function would be one where the voltage or power output would be simply proportional to the voltage or power control input signal:

$$V_{out} = K_{ctl} V_{ctl}$$

Where  $V_{out}$  is the pulse voltage output;  
 $K_{ctl}$  is a gain constant (within power control block 1014, not to be confused with  $K_1$ ); and  
 $V_{ctl}$  is the control voltage input (power control command signal).

An example of an expanded gain control function could be:

$$V_{out} = K_{ctl} V_{ctl}^2$$

With this function, a control input increment of one volt from nine to ten volts produces a greater power output change than a control input increment of one volt from one to two volts, hence gain expansion.

5 An excellent expansion function is exponential:

$$V_{out} = K_{ctl} \exp(V_{ctl})$$

With this function, the output fractional (percentage) change is the same for a given input control voltage difference at any control level. This stabilizes the responsiveness of the power control loop over many orders of magnitude of signal strength.

10 This function can be implemented with a exponential gain control device, or a separate exponential function device together with a linear gain control device. An embodiment using a exponential gain control device is described in relation to Fig. 20. In this embodiment, operation is much the same as previously described for the linear power control case except that now the power control function 2018 controls the power output in a manner such that the power output, expressed in decibels (dB), is substantially proportional to the power control input voltage 2016 ( $V_{ctl}$ ) (also referred to as, the power control command signal).

15 An alternative embodiment employing a separate exponential function and a linear gain control device will now be described with reference to Fig. 29. A signal 2002 ( $V_{out}$ ) having a transmitted power level is disturbed by the propagation path according to a disturbance 2202. The resulting received signal 2104 is evaluated for signal to noise ratio 2204 and compared with the desired signal to noise reference 2112. The result is then scaled by  $K_1$  2012 and summed or integrated over time by integrator 2014 to produce an output 2902. This output 25 2902 drives an exponential function 2904 to yield a power control command

signal 2906 to command the power control function 2018 (1126 in Fig. 11) of a transmitter to output a signal 2002 ( $V_{out}$ ) having a new power level.

It should be apparent to one skilled in the art that the system functions illustrated in Fig. 29 from the reference 2112 to the exponential function 2904  
5 can be partitioned into either the transmitter or receiver at the convenience of the designer. This embodiment can be modified to use BER information and log(BER) information as shown in Figs. 22 and 23.

Where exponential power control and integration gain power control methods are combined, algorithm simplicity can result. The number of pulses is  
10 determined by the following relationship:

$$N_p = 2^{K_p P}$$

Where  $N_p$  is the number of pulses per data bit to be transmitted;

$P$  is the power control command; and

$K_p$  is a scaling constant.

15 In one embodiment,  $N_p$  is the only value in the above equation that is rounded to an integer. In another embodiment, greater implementation simplicity may be achieved by rounding the product  $K_p P$  to an integer value. Thus, only power of two values need to be generated. In this embodiment, a command for  
20 lower power results in half of the present number of pulses per data bit being transmitted. Conversely, a command for more power results in twice the present number of pulses per data bit being transmitted. For example, in a system designed for full power at 128 pulses per bit, the product  $K_p P = 7$  commands full power. Thus  $K_p = 7/P_{max}$  such that the maximum value of  $P$  yields  $K_p P = 7$ .  
25 Because this represents fairly coarse steps in power increment, hysteresis can be used to advantage in the rounding of the  $K_p P$  value to prevent instability at the rounding threshold.



#### IV.4.c. Power Control In Combination With Variable Data Rate

Impulse radio systems lend themselves to adaptively changing the data rate according to data needs and link propagation conditions. The combination of power control methods and variable data rate methods requires special considerations. This is because it is not always advantageous to use power control to reduce signal power and minimize interference.

For example, in data systems, it is advantageous to use the maximum data rate possible for the link range and interference conditions, keeping the power at the maximum. Thus, power control would only be used where there is excess received signal at the maximum data rate available to the transceiver system. That is, where a transceiver is already transmitting at its maximum data rate, power control could be used to decrease power so long as such a decrease in power does not cause the data rate to decrease. For a constant message rate, the average interference is the same whether a high power/high data rate message is transmitted for a short time or whether a low power/low data rate message is transmitted over a longer time. The user of a computer system, however, would usually prefer the message to be transmitted in a short time.

In digital voice systems with constant data rate modems and compression/expansion algorithms, power control is the only option. In such systems, the power should be minimized. (It is, however, possible to send the data in blocks or packets at a burst rate higher than the average data rate.)

In digital voice systems with variable data rate modems and compression/expansion algorithms, the power can be minimized during low data rate intervals to minimize interference. In this case, it is also possible to maintain maximum power and maximum data rate, but to turn off the transmitter for intervals when no data is available.

### *Conclusion*

While various embodiments of the present invention have been described above, it should be understood that they have been presented by way of example, and not limitation. For instance, although the exemplary system embodiment in this patent application is an impulse radio using a 2.0 GHz center frequency, 5 impulse radio systems with a center frequency from below audio to microwave, millimeter wave, tera-Hertz, and even optical frequencies may benefit from this invention. In addition, some of the embodiments, such as the power control embodiments incorporating integration gain power control and gain expansion 10 power control, may be of benefit to spread spectrum radio systems in general (that is, spread spectrum radio systems that do not employ impulse radio communications). Further, the transmission wave may be electromagnetic or acoustic.

Thus the breadth and scope of the present invention should not be limited 15 by any of the above-described exemplary embodiments, but should be defined only in accordance with the following claims and their equivalents.

*In the Claims:*

1. A method for power control in an impulse radio system, comprising the steps of:

transmitting an impulse radio signal from a first transceiver;

5 receiving said impulse radio signal at a second transceiver;

determining at least one performance measurement of said received impulse radio signal;

calculating a power control update according to said at least one performance measurement of said received impulse radio signal; and

10 controlling the output power of at least one of said first transceiver and said second transceiver according to said power control update.

2. The method of claim 1, wherein said at least one performance measurement is selected from the group consisting of bit error rate, signal-to-noise ratio, and received signal strength.

15 3. The method of claim 1, further comprising the step of summing said power control update with at least one additional power control update to produce a power control command, and wherein said step of controlling comprises controlling the output power of at least one of said first transceiver and said second transceiver according to said power control command.

20 4. The method of claim 1, wherein said step of calculating is performed at said second transceiver.

25 5. The method of claim 4, wherein said step of controlling comprises controlling said output power of said second transceiver according to said power control update.

5           6.       The method of claim 5, further comprising the step of transmitting a further impulse radio signal from said second transceiver, and wherein said step of controlling said output power of said second transceiver comprises controlling the integration gain of said further impulse radio signal according to said power control update.

10           7.       The method of claim 5, further comprising the step of transmitting a further impulse radio signal from said second transceiver, and wherein said step of controlling said output power of said second transceiver comprises controlling the pulse peak power of said further impulse radio signal according to said power control update.

15           8.       The method of claim 5, further comprising the step of transmitting a further impulse radio signal from said second transceiver, and wherein said step of controlling said output power of said second transceiver comprises controlling the pulse height of said further impulse radio signal according to said power control update.

          9.       The method of claim 5, wherein said step of transmitting said impulse radio signal comprises transmitting a pulse train including a quantity  $N_{\text{train}}$  of pulses for each bit of information,  
          further comprising the step of transmitting a further impulse radio signal  
20       from said second transceiver, wherein said step of transmitting said further impulse radio signal comprises transmitting a pulse train including a quantity  $N_{\text{train}2}$  of pulses for each bit of information, and  
          wherein said step of controlling said output power of said second transceiver comprises controlling said quantity  $N_{\text{train}2}$  of pulses according to said  
25       power control update.

10. The method of claim 9, further comprising the step of providing said second transceiver with information related to said quantity  $N_{train}$  of pulses by including said information in a header of said impulse radio signal.

5 11. The method of claim 9, further comprising the step of providing said second transceiver with information related to said quantity  $N_{train}$  of pulses by including said information in control signals transmitted by said first transceiver.

12. The method of claim 9, wherein said step of controlling said quantity  $N_{train2}$  comprises calculating said quantity  $N_{train2}$  of pulses according to:

$$N_{train2} = K_p (P_{n-1} + dP)$$

where  $K_p$  is a constant relating power to number of pulses per bit,  $P_{n-1}$  is the power level used to transmit a previous impulse radio signal from said second impulse radio transceiver, and  $dP$  is said power control update..

15 13. The method of claim 9, wherein said quantity  $N_{train}$  of pulses comprises a quantity  $N_{period}$  of periods, and wherein each period comprises a quantity  $N_{pulses-per-period}$  of pulses,

wherein said quantity  $N_{train2}$  of pulses comprises a quantity  $N_{period2}$  of periods, and wherein each period comprises a quantity  $N_{pulses-per-period2}$  of pulses,  
20 and

wherein said step of controlling said quantity  $N_{train2}$  of pulses comprises controlling said quantity  $N_{pulses-per-period2}$  of pulses.

14. The method of claim 9, wherein said quantity  $N_{train}$  of pulses comprises a quantity  $N_{period}$  of periods, and wherein each period comprises a  
25 quantity  $N_{pulses-per-period}$  of pulses,

wherein said quantity  $N_{\text{train}2}$  of pulses comprises a quantity  $N_{\text{period}2}$  of periods, and wherein each period comprises a quantity  $N_{\text{pulses-per-period}2}$  of pulses, and

5 wherein said step of controlling said quantity  $N_{\text{train}2}$  of pulses comprises controlling said quantity  $N_{\text{period}2}$  of periods.

15. The method of claim 1, wherein said step of calculating is performed at said second transceiver,

10 further comprising the step of transmitting said power control update from said second transceiver to said first transceiver between said calculating step and said controlling step, and

wherein said controlling step comprises controlling said output power of said first transceiver according to said power control update.

16. The method of claim 1, further comprising the step of transmitting said at least one performance measurement from said second transceiver to said first transceiver between said determining step and said calculating step,

wherein said calculating step is performed at said first transceiver, and

wherein said controlling step comprises controlling said output power of said first transceiver according to said power control update.

20 17. The method of claim 1, wherein said controlling step comprises controlling said output power of said first transceiver according to said power control update.

25 18. The method of claim 17, further comprising the step of transmitting a further impulse radio signal from said first transceiver, and wherein said step of controlling said output power of said first transceiver comprises controlling a number of pulses of said further impulse radio signal according to said power control update.

19. The method of claim 17, further comprising the step of transmitting a further impulse radio signal from said first transceiver, and wherein said step of controlling said output power of said first transceiver comprises controlling the pulse peak power of said further impulse radio signal according to said power control update.

20. The method of claim 17, further comprising the step of transmitting a further impulse radio signal from said first transceiver, and wherein said step of controlling said output power of said first transceiver comprises controlling the pulse height of said further impulse radio signal according to said power control update.

21. The method of claim 17, wherein said step of transmitting said impulse radio signal comprises transmitting a pulse train including a quantity  $N_{\text{train}}$  of pulses for each bit of information, further comprising the step of transmitting a further impulse radio signal from said first transceiver, wherein said step of transmitting said further impulse radio signal comprises transmitting a pulse train including a quantity  $N_{\text{train}2}$  of pulses for each bit of information, and wherein said step of controlling said output power of said first transceiver comprises controlling said quantity  $N_{\text{train}2}$  of pulses according to said power control update.

22. The method of claim 21, further comprising the step of providing said second transceiver with information related to said quantity  $N_{\text{train}}$  of pulses by including said information in a header of said impulse radio signal.

23. The method of claim 21, further comprising the step of providing said second transceiver with information related to said quantity  $N_{\text{train}}$  of pulses

by including said information in control signals transmitted by said first transceiver.

24. The method of claim 21, wherein said step of controlling said quantity  $N_{\text{train}2}$  comprises calculating said quantity  $N_{\text{train}2}$  according to:

5

$$N_{\text{train}2} = K_p (P_{n-1} + dP)$$

where  $K_p$  is a constant relating power to number of pulses per bit,  $P_{n-1}$  is the power level used to transmit said impulse radio signal from said first impulse radio transceiver, and  $dP$  is said power control update.

25. The method of claim 21, wherein said quantity  $N_{\text{train}}$  of pulses comprises a quantity  $N_{\text{period}}$  of periods, and wherein each period comprises a quantity  $N_{\text{pulses-per-period}}$  of pulses,

10

wherein said quantity  $N_{\text{train}2}$  of pulses comprises a quantity  $N_{\text{period}2}$  of periods, and wherein each period comprises a quantity  $N_{\text{pulses-per-period}2}$  of pulses, and

15

wherein said step of controlling said quantity  $N_{\text{train}2}$  of pulses comprises controlling said quantity  $N_{\text{pulses-per-period}2}$  of pulses.

26. The method of claim 21, wherein said quantity  $N_{\text{train}}$  of pulses comprises a quantity  $N_{\text{period}}$  of periods, and wherein each period comprises a quantity  $N_{\text{pulses-per-period}}$  of pulses,

20

wherein said quantity  $N_{\text{train}2}$  of pulses comprises a quantity  $N_{\text{period}2}$  of periods, and wherein each period comprises a quantity  $N_{\text{pulses-per-period}2}$  of pulses, and

wherein said step of controlling said quantity  $N_{\text{train}2}$  of pulses comprises controlling said quantity  $N_{\text{period}2}$  of periods.

25

27. The method of claim 1, wherein said step of determining comprises determining the signal strength of said received impulse radio signal,



and wherein said step of calculating comprises calculating said power control update according to:

$$dP = K(P_{ref} - P_{SI})$$

5 where dP is said power control update, where K is a gain constant,  $P_{SI}$  is the signal strength of said received impulse radio signal, and  $P_{ref}$  is a signal strength reference.

28. The method of claim 1, wherein said step of determining comprises determining the signal-to-noise ratio of said received impulse radio signal, and wherein said step of calculating comprises calculating said power control update according to:

$$dP = K(SNR_{ref} - SNR_{SI})$$

10 where dP is said power control update, K is a gain constant,  $SNR_{SI}$  is the signal-to-noise ratio of said received impulse radio signal, and  $SNR_{ref}$  is a signal-to-noise ratio reference.

29. The method of claim 1, wherein said step of determining comprises determining the bit error rate of said received impulse radio signal, and wherein said step of calculating comprises calculating said power control update according to:

$$dP = K(BER_{SI} - BER_{ref})$$

20 where dP is said power control update, K is a gain constant,  $BER_{SI}$  is the bit error rate of said received impulse radio signal, and  $BER_{ref}$  is a bit error rate reference.

30. The method of claim 1, wherein said step of determining comprises determining the bit error rate and the signal strength of said received impulse radio signal, and wherein said step of calculating comprises calculating said power control update according to:

$$P_{ref} = K_2(BER_{SI} - BER_{ref})$$

$$dP = K_1(P_{ref} - P_{SI})$$

where  $dP$  is said power control update,  $K_1$  and  $K_2$  are gain constants,  $BER_{S1}$  is the bit error rate of said received impulse radio signal,  $BER_{ref}$  is a bit error rate reference, and  $P_{S1}$  is the signal strength of said received impulse radio signal.

31. The method of claim 1, wherein said step of determining  
5 comprises determining the bit error rate and the signal-to-noise ratio of said received impulse radio signal, and wherein said step of calculating comprises calculating said power control update according to:

$$SNR_{ref} = K_2(BER_{S1} - BER_{ref})$$

$$dP = K_1(SNR_{ref} - SNR_{S1})$$

10 where  $dP$  is said power control update,  $K_1$  and  $K_2$  are gain constants,  $BER_{S1}$  is the bit error rate of said received impulse radio signal,  $BER_{ref}$  is a bit error rate reference, and  $SNR_{S1}$  is the signal-to-noise ratio of said received impulse radio signal.

32. The method of claim 1, wherein said step of determining  
15 comprises determining the signal-to-noise ratio and the signal strength of said received impulse radio signal, and wherein said step of calculating comprises calculating said power control update according to:

$$P_{ref} = K_2(SNR_{ref} - SNR_{S1})$$

$$dP = K_1(P_{ref} - P_{S1})$$

20 where  $dP$  is said power control update,  $K_1$  and  $K_2$  are gain constants,  $SNR_{S1}$  is the signal-to-noise ratio of said received impulse radio signal,  $SNR_{ref}$  is a signal-to-noise ratio reference, and  $P_{S1}$  is the signal strength of said received impulse radio signal.

33. The method of claim 1, wherein said step of determining  
25 comprises determining the bit error rate of said received impulse radio signal, and wherein said step of calculating comprises calculating said power control update according to:

$$dP = K (\log(BER_{s1}) - \log(BER_{ref}))$$

where dP is said power control update, K is a gain constant, BER<sub>s1</sub> is the bit error rate of said received impulse radio signal, BER<sub>ref</sub> is a bit error rate reference, and log is the logarithm function.

5                   34. The method of claim 1, wherein said step of determining comprises determining the bit error rate and the signal strength of said received impulse radio signal, and wherein said step of calculating comprises calculating said power control update according to:

$$P_{ref} = K_2(\log(BER_{s1}) - \log(BER_{ref}))$$

$$10 \quad dP = K_1(P_{ref} - P_{s1})$$

where dP is said power control update, K<sub>1</sub> and K<sub>2</sub> are gain constants, BER<sub>s1</sub> is the bit error rate of said received impulse radio signal, BER<sub>ref</sub> is a bit error rate reference, log is the logarithm function, P<sub>s1</sub> is the signal strength of said received impulse radio signal, and P<sub>ref</sub> is a signal strength reference.

15                   35. The method of claim 1, wherein said step of determining comprises determining the bit error rate and the signal-to-noise ratio of said received impulse radio signal, and wherein said step of calculating comprises calculating said power control update according to:

$$SNR_{ref} = K_2(\log(BER_{s1}) - \log(BER_{ref}))$$

$$20 \quad dP = K_1(SNR_{ref} - SNR_{s1})$$

where dP is said power control update, K<sub>1</sub> and K<sub>2</sub> are gain constants, BER<sub>s1</sub> is the bit error rate of said received impulse radio signal, BER<sub>ref</sub> is a bit error rate reference, log is the logarithm function, and SNR<sub>s1</sub> is the signal-to-noise ratio of said received impulse radio signal.

25                   36. A method for power control in an impulse radio system, comprising the steps of:

transmitting an impulse radio signal from a first transceiver;

receiving said impulse radio signal at a second transceiver;  
determining at least one signal performance measurement based on said  
received impulse radio signal;  
determining a power control update based on said at least one signal  
performance measurement;  
5 determining a power control command based on at least said power  
control update; and  
controlling the output power of at least one of said first transceiver and  
said second transceiver according to said power control command.

10 37. The method of claim 36, wherein said step of controlling the  
output power comprises controlling the output power according to:

$$V_{out} = K_{ctl} V_{ctl}$$

where  $V_{out}$  is said output power,  $K_{ctl}$  is a gain constant, and  $V_{ctl}$  is said power  
control command.

15

38. The method of claim 36, wherein said step of controlling the  
output power comprises controlling the output power according to:

$$V_{out} = K_{ctl} V_{ctl}^2$$

where  $V_{out}$  is said output power,  $K_{ctl}$  is a gain constant, and  $V_{ctl}$  is said power  
control command.

20

39. The method of claim 36, wherein said step of controlling the  
output power comprises controlling the output power according to:

$$V_{out} = K_{ctl} \exp(V_{ctl})$$

where  $V_{out}$  is said output power,  $K_{ctl}$  is a gain constant, and  $V_{ctl}$  is said power  
control command.

25

40. An impulse radio transceiver, wherein said transceiver communicates with a second impulse radio transceiver, said impulse radio transceiver comprising:

an impulse radio transmitter;

5 an impulse radio receiver, wherein said receiver receives an impulse radio signal from the second impulse transceiver;

a power adjuster that calculates a power control update according to at least one performance measurement of said received impulse radio signal; and

10 a power controller that controls the output power of said impulse radio transmitter according to said power control update.

41. The transceiver of claim 40, further comprising a signal evaluator for determining said at least one performance measurement of said received impulse radio signal.

42. The transceiver of claim 40, wherein said at least one performance measurement is selected from the group of bit error rate, signal-to-noise ratio, and received signal power.

43. The transceiver of claim 40, further comprising an integrator for summing said power control update with at least one additional power control update to produce a power control command, and wherein said power controller controls the output power of said impulse radio transmitter according to said power control command.

44. The transceiver of claim 40, wherein said power controller controls the output power by controlling the integration gain of said impulse radio transmitter according to said power control update.

45. The transceiver of claim 40, wherein said power controller controls the output power by controlling the pulse peak power of impulse signals transmitted by said impulse radio transmitter, and wherein said controller controls the pulse peak power according to said power control update.

5 46. The transceiver of claim 40, wherein said power controller controls the output power by controlling the pulse height of impulse signals transmitted by said impulse radio transmitter, and wherein said controller controls the pulse height according to said power control update.

10 47. The transceiver of claim 40, wherein said impulse radio transmitter transmits a pulse train including a quantity  $N_{train}$  of pulses for each bit of information, and wherein said power controller controls the output power by controlling said quantity  $N_{train}$  of pulses according to said power control update.

48. The transceiver of claim 47, wherein said power controller calculates said quantity  $N_{train}$  according to:

15 
$$N_{train} = K_p (P_{n-1} + dP)$$

where  $K_p$  is a constant relating power to number of pulses per bit,  $P_{n-1}$  is the power level that said impulse radio transmitter used to transmit the previous impulse radio signal, and  $dP$  is said power control update.

20 49. The transceiver of claim 47, wherein said quantity  $N_{train}$  of pulses comprises a quantity  $N_{period}$  of periods, and wherein each period comprises a quantity  $N_{pulses-per-period}$  of pulses, and wherein said power controller controls the output power by controlling said quantity  $N_{pulses-per-period}$  of pulses according to said power control update.

25 50. The transceiver of claim 47, wherein said quantity  $N_{train}$  of pulses comprises a quantity  $N_{period}$  of periods, and wherein each period comprises a

quantity  $N_{\text{pulses-per-period}}$  of pulses, and wherein said power controller controls the output power by controlling said quantity  $N_{\text{period}}$  of pulses according to said power control update.

5 51. The transceiver of claim 40, wherein said at least one performance measurement comprises the signal strength of the received impulse radio signal, and wherein said power adjuster calculates said power control update according to:

$$dP = K(P_{\text{ref}} - P_{S1})$$

10 where  $dP$  is said power control update, where  $K$  is a gain constant,  $P_{S1}$  is the signal strength of said received impulse radio signal, and  $P_{\text{ref}}$  is a signal strength reference.

52. The transceiver of claim 51, further comprising a signal evaluator to determine the signal strength of said received impulse radio signal.

15 53. The transceiver of claim 40, wherein said at least one performance measurement comprises the signal-to-noise ratio of said received impulse radio signal, and wherein said power adjuster calculates said power control update according to:

$$dP = K(\text{SNR}_{\text{ref}} - \text{SNR}_{S1})$$

20 where  $dP$  is said power control update,  $K$  is a gain constant,  $\text{SNR}_{S1}$  is the signal-to-noise ratio of said received impulse radio signal, and  $\text{SNR}_{\text{ref}}$  is a signal-to-noise ratio reference.

54. The transceiver of claim 40, wherein said at least one performance measurement comprises the bit error rate of the received impulse radio signal, and wherein said power adjuster calculates said power control update according to:

25 
$$dP = K(\text{BER}_{S1} - \text{BER}_{\text{ref}})$$

where  $dP$  is said power control update,  $K$  is a gain constant,  $BER_{S1}$  is the bit error rate of said received impulse radio signal, and  $BER_{ref}$  is a bit error rate reference.

5 55. The transceiver of claim 40, wherein said at least one performance measurement comprises the bit error rate and the signal strength of the received impulse radio signal, and wherein said power adjuster calculates said power control update according to:

$$P_{ref} = K_2(BER_{S1} - BER_{ref})$$

$$dP = K_1(P_{ref} - P_{S1})$$

10 where  $dP$  is said power control update,  $K_1$  and  $K_2$  are gain constants,  $BER_{S1}$  is the bit error rate of said received impulse radio signal,  $BER_{ref}$  is a bit error rate reference, and  $P_{S1}$  is the signal strength of said received impulse radio signal.

15 56. The transceiver of claim 40, wherein said at least one performance measurement comprises the bit error rate and the signal-to-noise ratio of the received impulse radio signal, and wherein said power adjuster calculates said power control update according to:

$$SNR_{ref} = K_2(BER_{S1} - BER_{ref})$$

$$dP = K_1(SNR_{ref} - SNR_{S1})$$

20 where  $dP$  is said power control update,  $K_1$  and  $K_2$  are gain constants,  $BER_{S1}$  is the bit error rate of said received impulse radio signal,  $BER_{ref}$  is a bit error rate reference, and  $SNR_{S1}$  is the signal-to-noise ratio of said received impulse radio signal.

25 57. The transceiver of claim 40, wherein said at least one performance measurement comprises the signal-to-noise ratio and the signal strength of the received impulse radio signal, and wherein said power adjuster calculates said power control update according to:

$$P_{ref} = K_2(SNR_{ref} - SNR_{S1})$$

$$dP = K_1(P_{ref} - P_{S1})$$



where  $dP$  is said power control update,  $K_1$  and  $K_2$  are gain constants,  $SNR_{S1}$  is the signal-to-noise ratio of said received impulse radio signal,  $SNR_{ref}$  is a signal-to-noise ratio reference, and  $P_{S1}$  is the signal strength of said received impulse radio signal.

5                    58.     The transceiver of claim 40, wherein said at least one performance measurement comprises the bit error rate of the received impulse radio signal, and wherein said power adjuster calculates said power control update according to:

$$dP = K (\log(BER_{S1}) - \log(BER_{ref}))$$

10                    where  $dP$  is said power control update,  $K$  is a gain constant,  $BER_{S1}$  is the bit error rate of said received impulse radio signal,  $BER_{ref}$  is a bit error rate reference, and  $\log$  is the logarithm function.

15                    59.     The transceiver of claim 40, wherein said at least one performance measurement comprises the bit error rate and the signal strength of the received impulse radio signal, and wherein said power adjuster calculates said power control update according to:

$$P_{ref} = K_2(\log(BER_{S1}) - \log(BER_{ref}))$$

$$dP = K_1(P_{ref} - P_{S1})$$

20                    where  $dP$  is said power control update,  $K_1$  and  $K_2$  are gain constants,  $BER_{S1}$  is the bit error rate of said received impulse radio signal,  $BER_{ref}$  is a bit error rate reference,  $\log$  is the logarithm function, and  $P_{S1}$  is the signal strength of said received impulse radio signal.

25                    60.     The transceiver of claim 40, wherein said at least one performance measurement comprises the bit error rate and the signal-to-noise ratio of the received impulse radio signal, and wherein said power adjuster calculates said power control update according to:

$$SNR_{ref} = K_2(\log(BER_{S1}) - \log(BER_{ref}))$$

$$dP = K_1(SNR_{ref} - SNR_{S1})$$

where  $dP$  is said power control update,  $K_1$  and  $K_2$  are gain constants,  $BER_{S1}$  is the bit error rate of said received impulse radio signal,  $BER_{ref}$  is a bit error rate reference,  $\log$  is the logarithm function, and  $SNR_{S1}$  is the signal-to-noise ratio of said received impulse radio signal.

5           61. An impulse radio transceiver, wherein said transceiver communicates with a second impulse radio transceiver, said impulse radio transceiver comprising:

an impulse radio transmitter, wherein said transmitter transmits an impulse radio signal to the second impulse transceiver;

10           an impulse radio receiver, wherein said receiver receives information related to said transmitted impulse radio signal from the second transceiver; and

a power controller that controls the output power of said impulse radio transmitter according to said information related to said transmitted impulse radio signal.

15           62. The transceiver of claim 61, wherein said information related to said transmitted impulse radio signal comprises a power control update, and wherein said power controller controls the output power of said impulse radio transmitter according to said power control update.

20           63. The transceiver of claim 61, wherein said information related to said transmitted impulse radio signal comprises at least one performance measurement related to said transmitted impulse radio signal, further comprising a power adjuster that calculates a power control update according to said at least one performance measurement, and wherein said power controller controls the output power of said impulse radio transmitter according to said power control  
25           update.

64. The transceiver of claim 63, wherein said at least one performance measurement is selected from the group consisting of bit error rate, signal-to-noise ratio, and received signal power.

5 65. The transceiver of claim 63, wherein said power controller controls the output power by controlling the integration gain of said impulse radio transmitter according to said power control update.

10 66. The transceiver of claim 63, wherein said power controller controls the output power by controlling the pulse peak power of impulse signals transmitted by said impulse radio transmitter, and wherein said controller controls the pulse peak power according to said power control update.

67. The transceiver of claim 63, wherein said power controller controls the output power by controlling the pulse height of impulse signals transmitted by said impulse radio transmitter, and wherein said controller controls the pulse height according to said power control update.

15 68. The transceiver of claim 63, wherein said impulse radio transmitter transmits a pulse train including a quantity  $N_{train}$  of pulses for each bit of information, and wherein said power controller controls the output power by controlling said quantity  $N_{train}$  of pulses according to said power control update.

20 69. The transceiver of claim 68, wherein said power controller calculates said quantity  $N_{train}$  according to:

$$N_{train} = K_p (P_{n-1} + dP)$$

where  $K_p$  is a constant relating power to number of pulses per bit,  $P_{n-1}$  is the power level that said impulse radio transmitter used to transmit the previous impulse radio signal, and  $dP$  is said power control update.

70. The transceiver of claim 68, wherein said quantity  $N_{\text{train}}$  of pulses comprises a quantity  $N_{\text{period}}$  of periods, and wherein each period comprises a quantity  $N_{\text{pulses-per-period}}$  of pulses, and wherein said power controller controls the output power by controlling said quantity  $N_{\text{pulses-per-period}}$  of pulses according to said power control update.

71. The transceiver of claim 68, wherein said quantity  $N_{\text{train}}$  of pulses comprises a quantity  $N_{\text{period}}$  of periods, and wherein each period comprises a quantity  $N_{\text{pulses-per-period}}$  of pulses, and wherein said power controller controls the output power by controlling said quantity  $N_{\text{period}}$  of pulses according to said power control update.

72. The transceiver of claim 63, wherein said at least one performance measurement comprises the signal strength of said transmitted impulse radio signal, and wherein said power adjuster calculates said power control update according to:

$$dP = K(P_{\text{ref}} - P_{\text{SI}})$$

where  $dP$  is said power control update, where  $K$  is a gain constant,  $P_{\text{SI}}$  is the power of said transmitted impulse radio signal, and  $P_{\text{ref}}$  is a power reference.

73. The transceiver of claim 63, wherein said at least one performance measurement comprises the signal-to-noise ratio of said transmitted impulse radio signal, and wherein said power adjuster calculates said power control update according to:

$$dP = K(\text{SNR}_{\text{ref}} - \text{SNR}_{\text{SI}})$$

where  $dP$  is said power control update,  $K$  is a gain constant,  $\text{SNR}_{\text{SI}}$  is the signal-to-noise ratio of said transmitted impulse radio signal, and  $\text{SNR}_{\text{ref}}$  is a signal-to-noise ratio reference.

74. The transceiver of claim 63, wherein said at least one performance measurement comprises the bit error rate of said transmitted impulse radio signal, and wherein said power adjuster calculates said power control update according to:

$$dP = K (BER_{s1} - BER_{ref})$$

where  $dP$  is said power control update,  $K$  is a gain constant,  $BER_{s1}$  is the bit error rate of said transmitted impulse radio signal, and  $BER_{ref}$  is a bit error rate reference.

75. The transceiver of claim 63, wherein said at least one performance measurement comprises the bit error rate and the signal strength of said transmitted impulse radio signal, and wherein said power adjuster calculates said power control update according to:

$$P_{ref} = K_2 (BER_{s1} - BER_{ref})$$

$$dP = K_1 (P_{ref} - P_{s1})$$

where  $dP$  is said power control update,  $K_1$  and  $K_2$  are gain constants,  $BER_{s1}$  is the bit error rate of said transmitted impulse radio signal,  $BER_{ref}$  is a bit error rate reference, and  $P_{s1}$  is the power of said transmitted impulse radio signal.

76. The transceiver of claim 63, wherein said at least one performance measurement comprises the bit error rate and the signal-to-noise ration of said transmitted impulse radio signal, and wherein said power adjuster calculates said power control update according to:

$$SNR_{ref} = K_2 (BER_{s1} - BER_{ref})$$

$$dP = K_1 (SNR_{ref} - SNR_{s1})$$

where  $dP$  is said power control update,  $K_1$  and  $K_2$  are gain constants,  $BER_{s1}$  is the bit error rate of said transmitted impulse radio signal,  $BER_{ref}$  is a bit error rate reference, and  $SNR_{s1}$  is the signal-to-noise ratio of said transmitted impulse radio signal.

77. The transceiver of claim 63, wherein said at least one performance measurement comprises the signal-to-noise ratio and the signal strength of said transmitted impulse radio signal, and wherein said power adjuster calculates said power control update according to:

$$P_{ref} = K_2(SNR_{ref} - SNR_{S1})$$

$$dP = K_1(P_{ref} - P_{S1})$$

where dP is said power control update,  $K_1$  and  $K_2$  are gain constants,  $SNR_{S1}$  is the signal-to-noise ratio of said transmitted impulse radio signal,  $SNR_{ref}$  is a signal-to-noise ratio reference, and  $P_{S1}$  is the power of said transmitted impulse radio signal.

78. The transceiver of claim 63, wherein said at least one performance measurement comprises the bit error rate of said transmitted impulse radio signal, and wherein said power adjuster calculates said power control update according to:

$$dP = K (\log(BER_{S1}) - \log(BER_{ref}))$$

where dP is said power control update, K is a gain constant,  $BER_{S1}$  is the bit error rate of said transmitted impulse radio signal,  $BER_{ref}$  is a bit error rate reference, and log is the logarithm function.

79. The transceiver of claim 63, wherein said at least one performance measurement comprises the bit error rate and the signal strength of said transmitted impulse radio signal, and wherein said power adjuster calculates said power control update according to:

$$P_{ref} = K_2(\log(BER_{S1}) - \log(BER_{ref}))$$

$$dP = K_1(P_{ref} - P_{S1})$$

where dP is said power control update,  $K_1$  and  $K_2$  are gain constants,  $BER_{S1}$  is the bit error rate of said transmitted impulse radio signal,  $BER_{ref}$  is a bit error rate reference, log is the logarithm function, and  $P_{S1}$  is the power of said transmitted impulse radio signal.

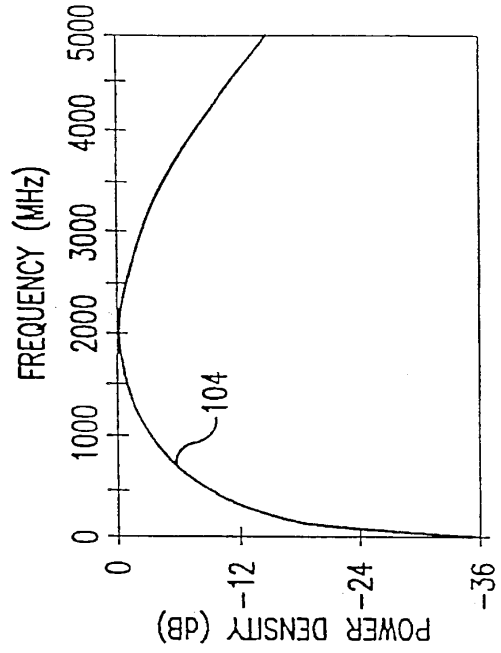


FIG.1B

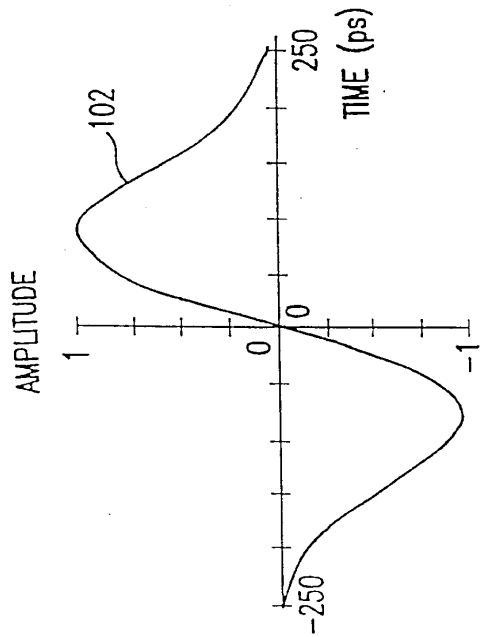


FIG.1A

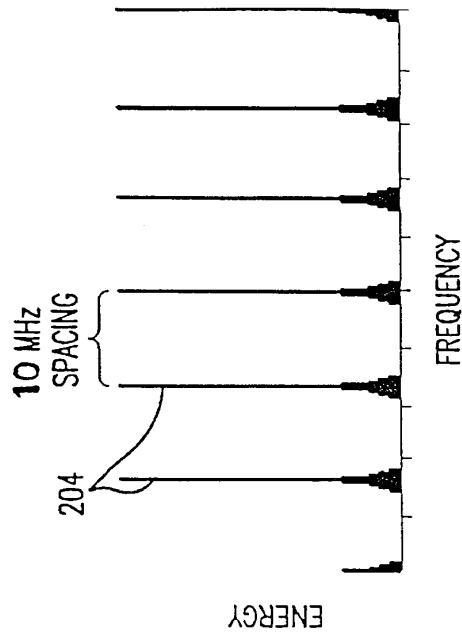


FIG.2B

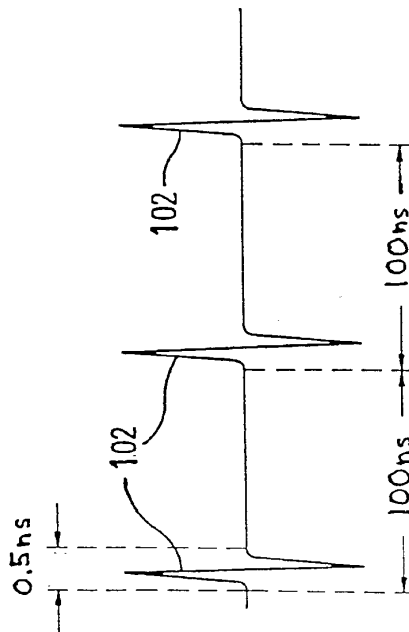


FIG.2A



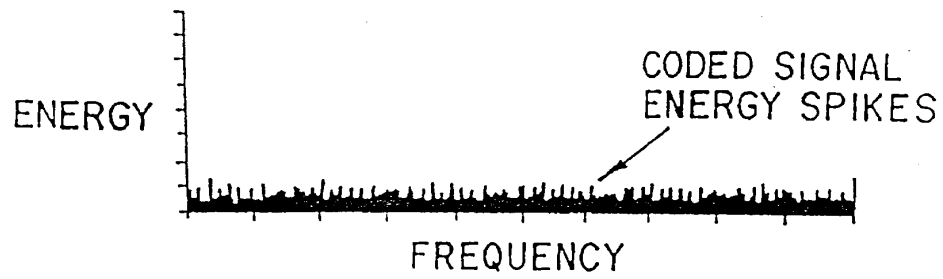


FIG. 3

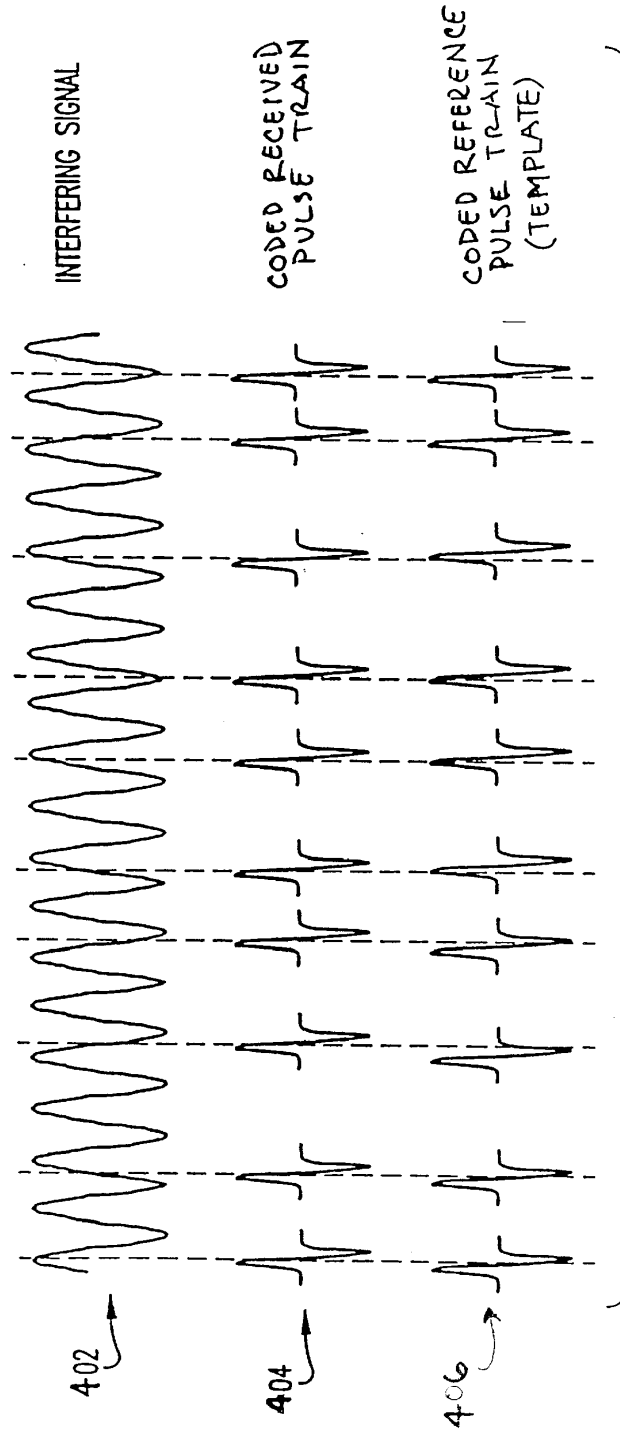


FIG. 4

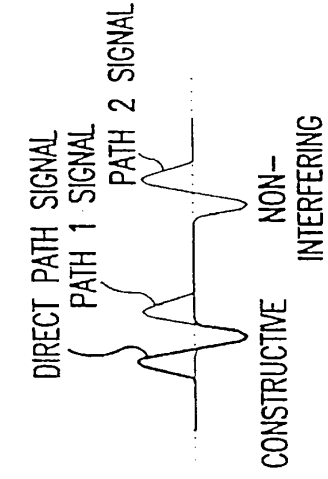


FIG.5B

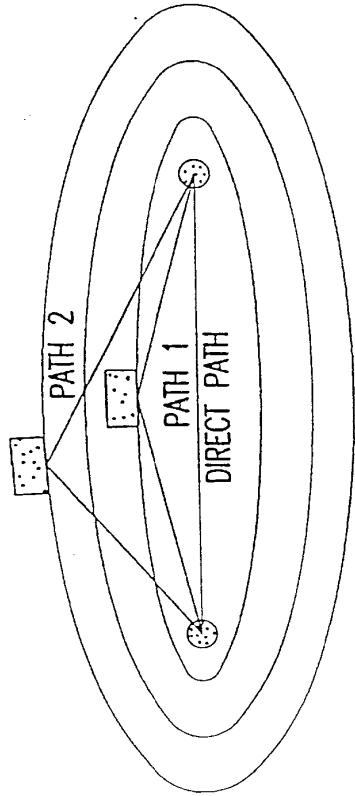


FIG.5A

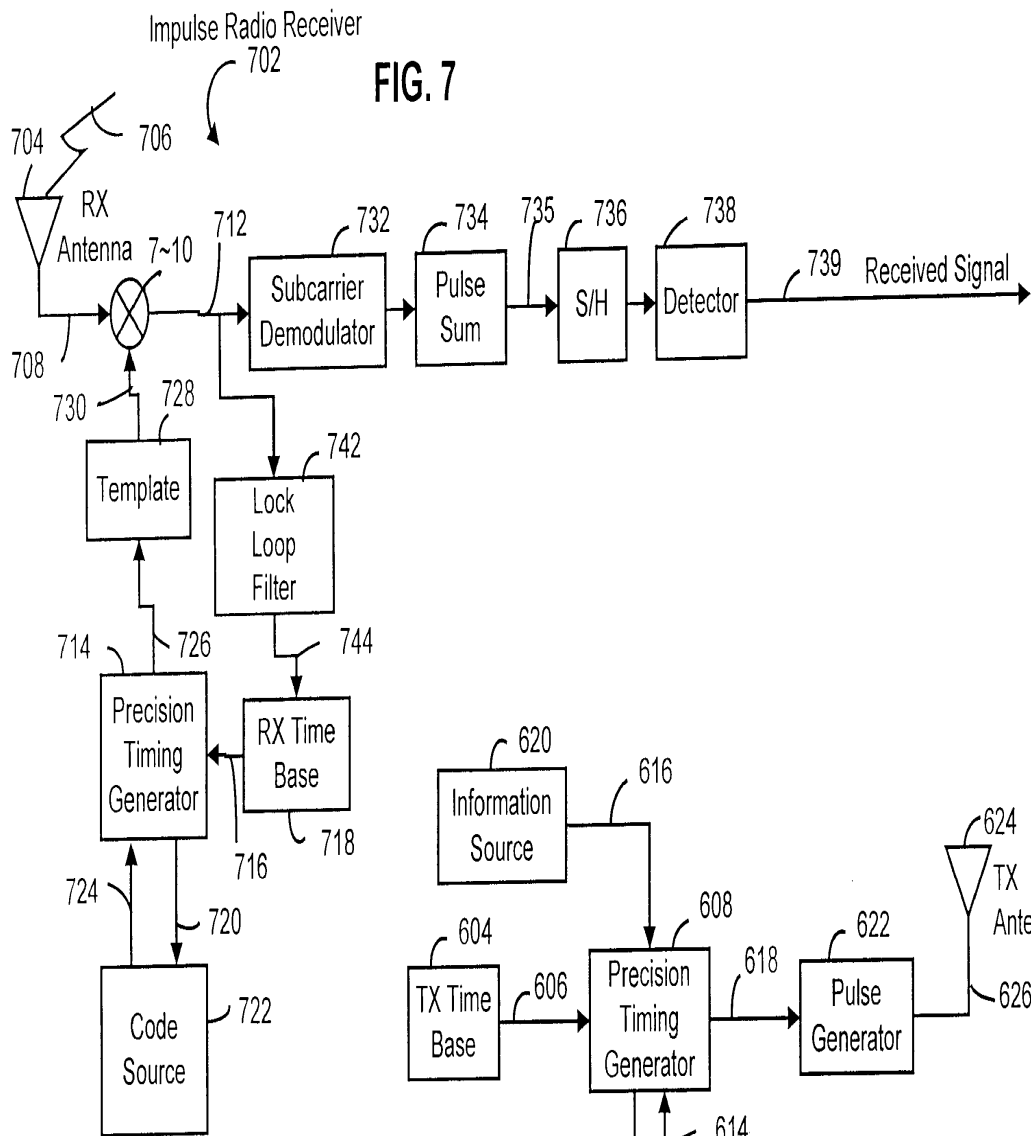


FIG. 7

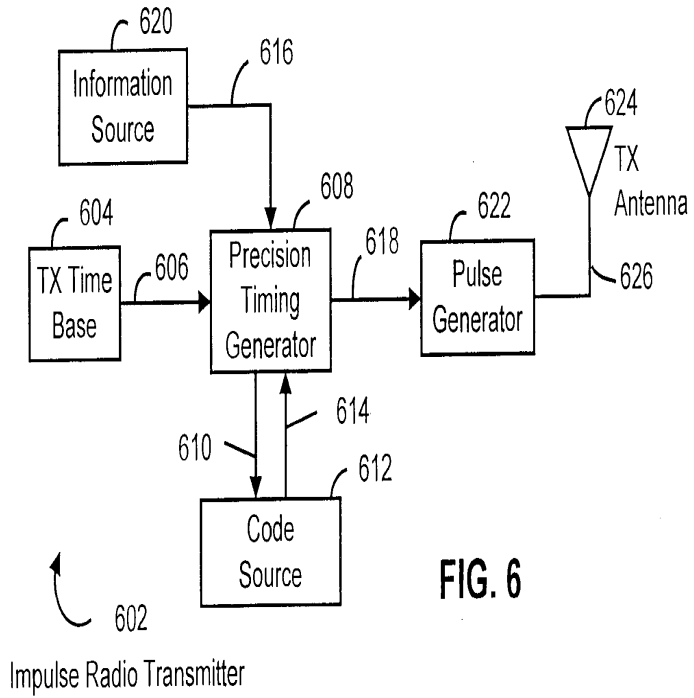


FIG. 6

Impulse Radio Transmitter

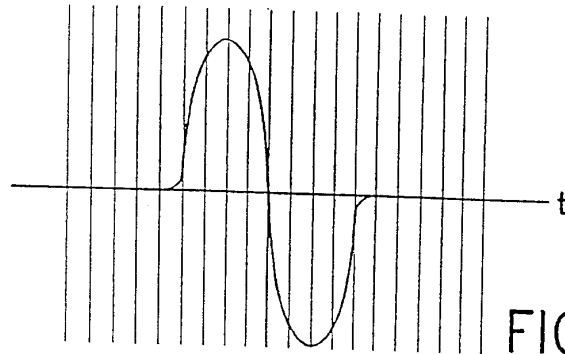


FIG. 8A

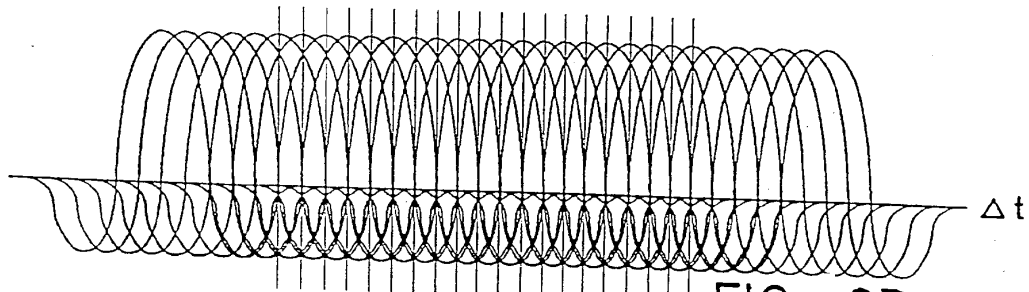


FIG. 8B

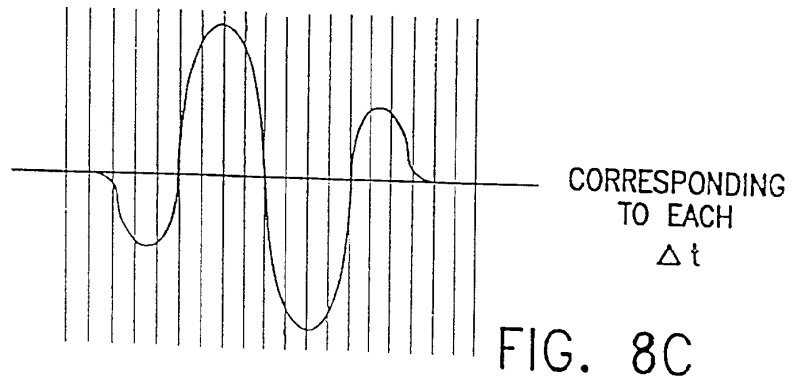


FIG. 8C

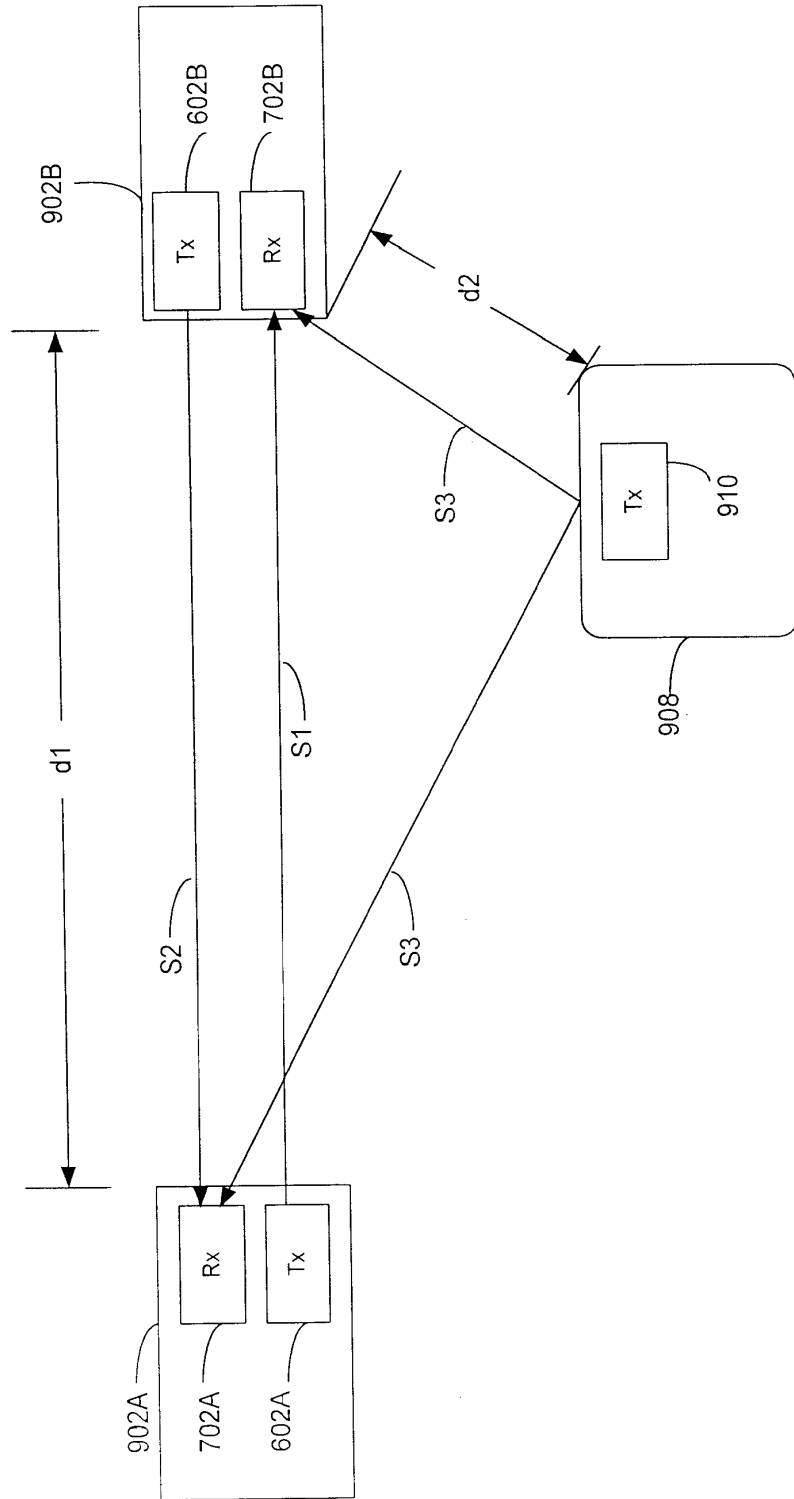


FIG. 9

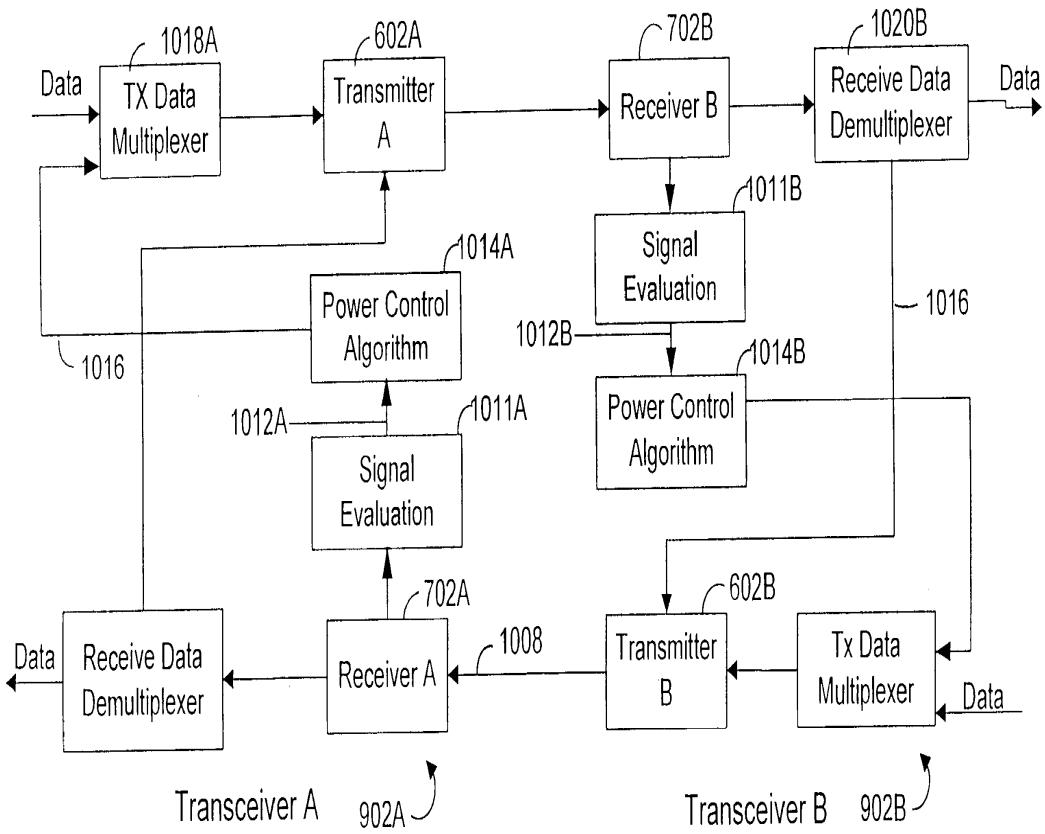


FIG. 10

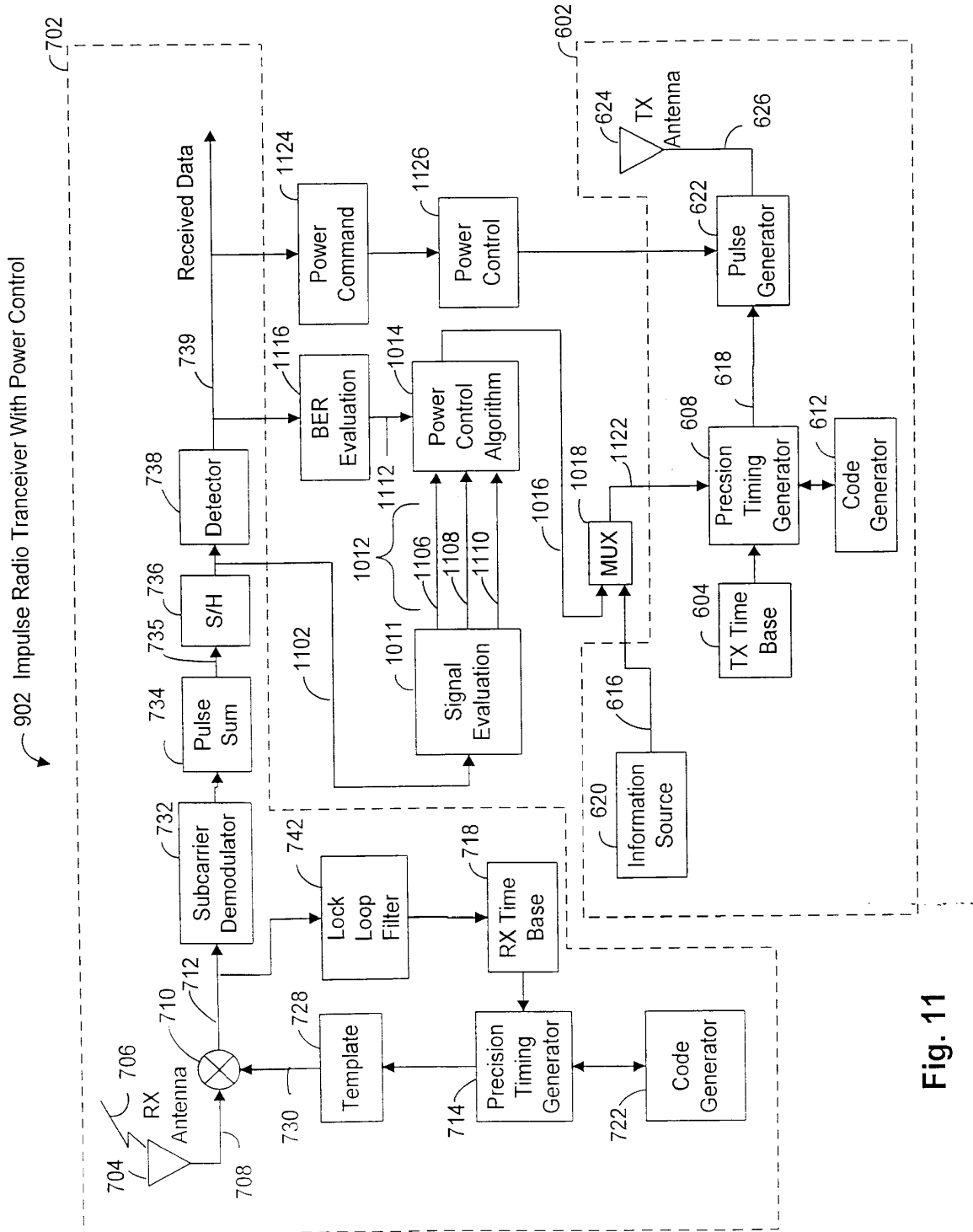


Fig. 11



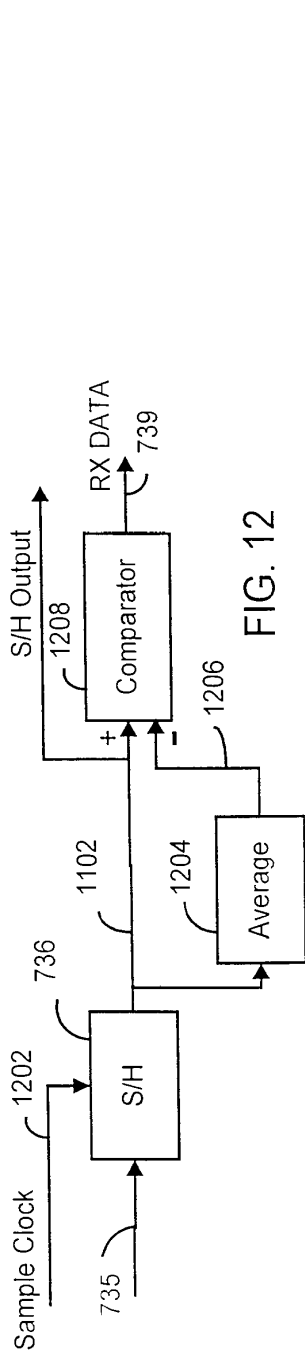


FIG. 12

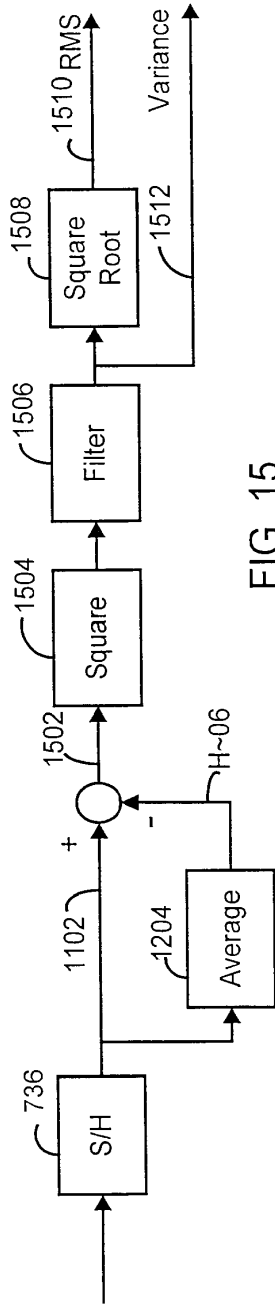


FIG. 15

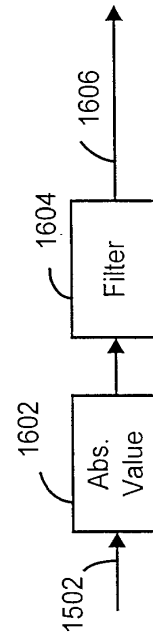


FIG. 16

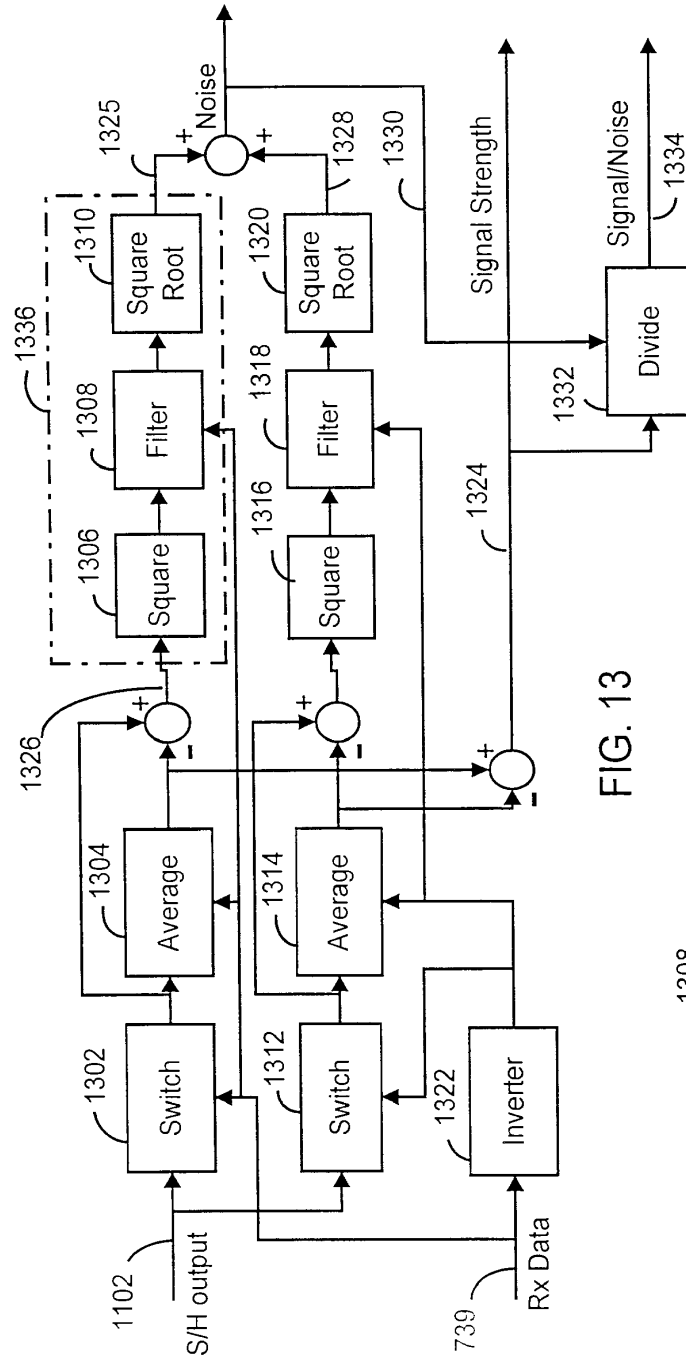


FIG. 13

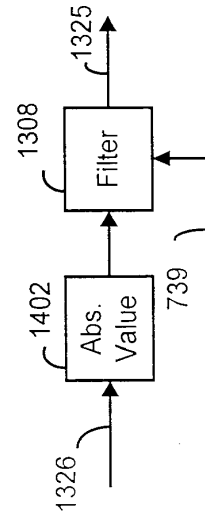


FIG. 14.

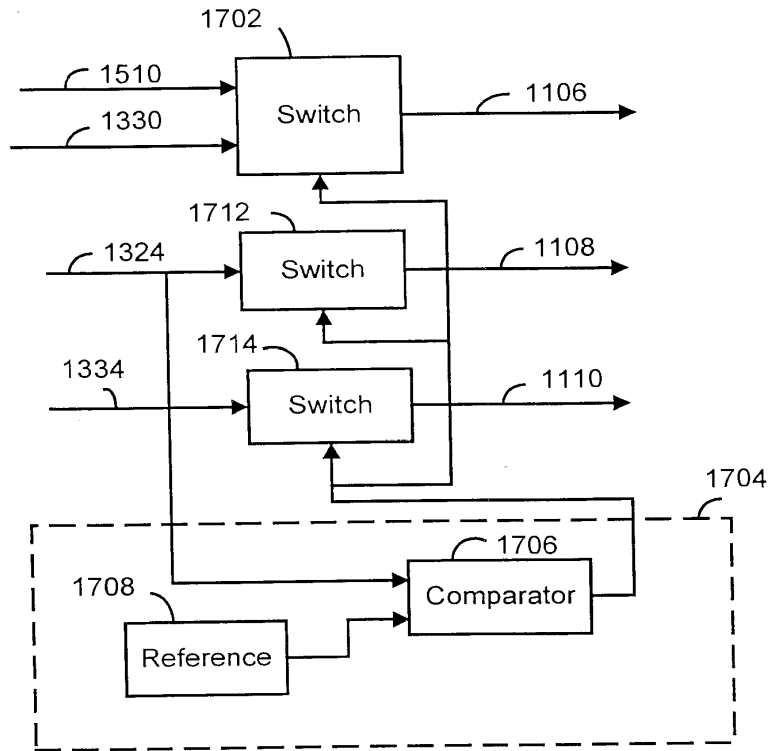


FIG. 17

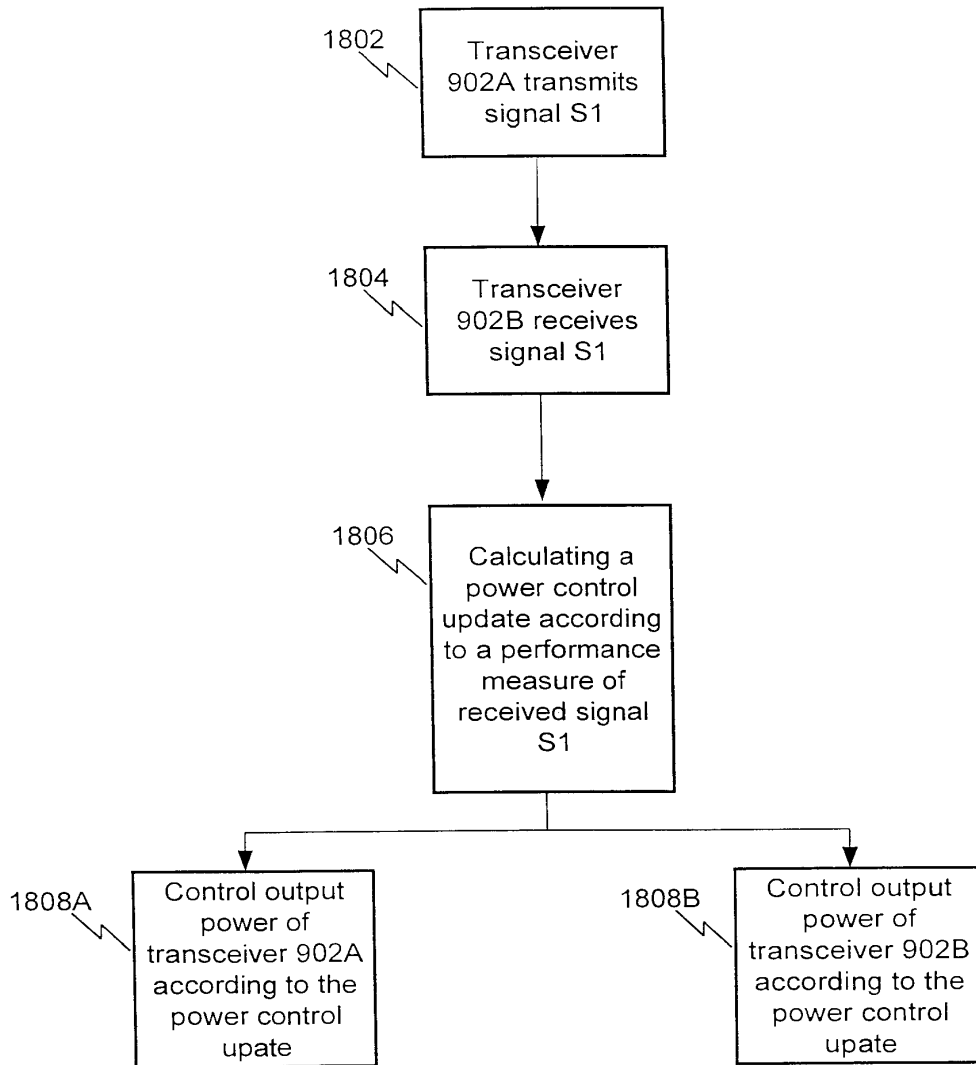


FIG. 18

1802A

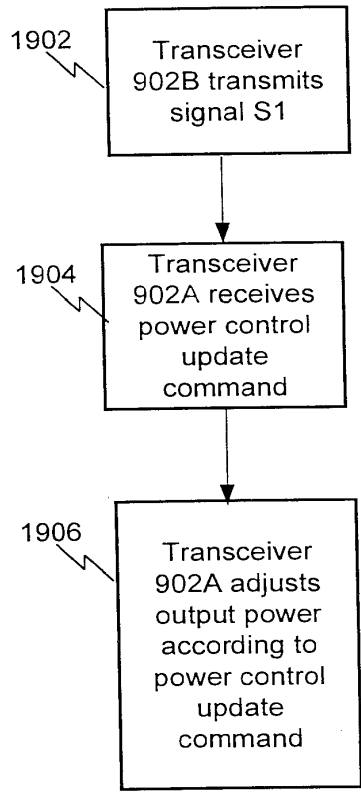


FIG. 19

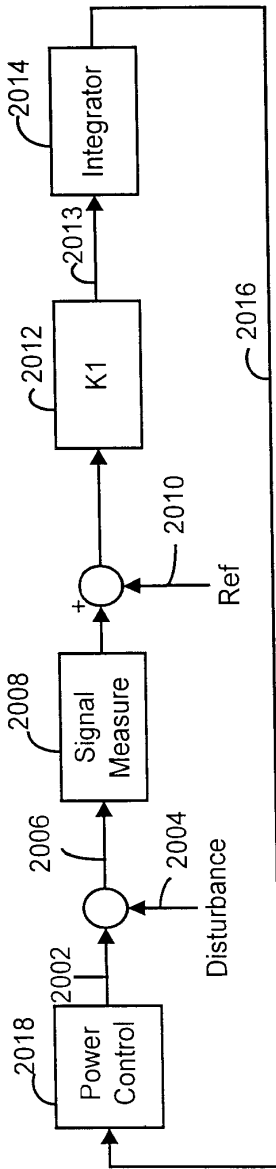


FIG. 20

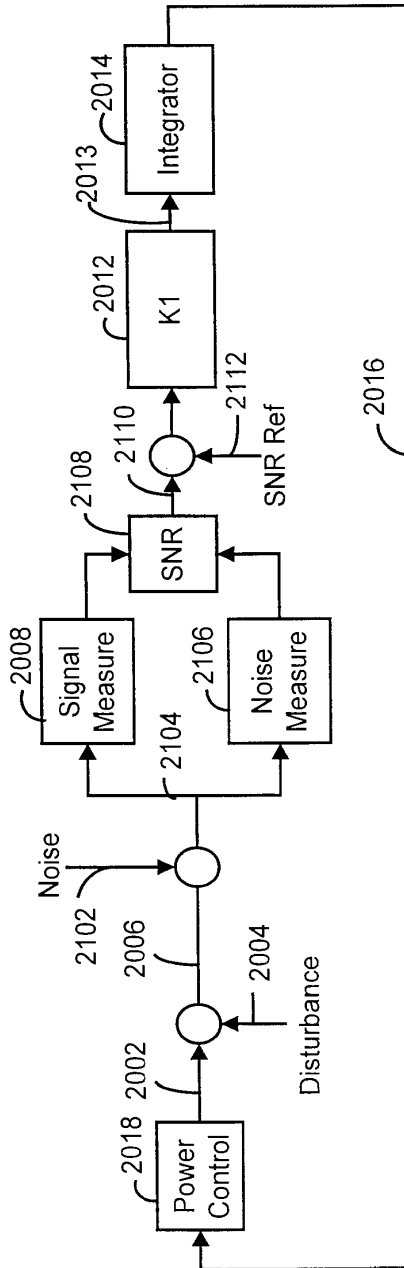


FIG. 21

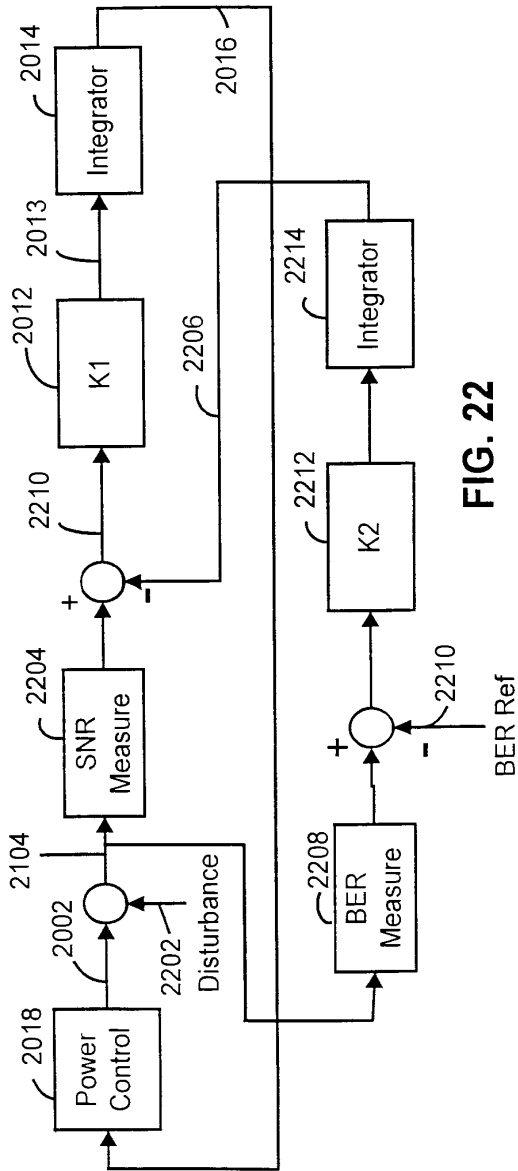


FIG. 22

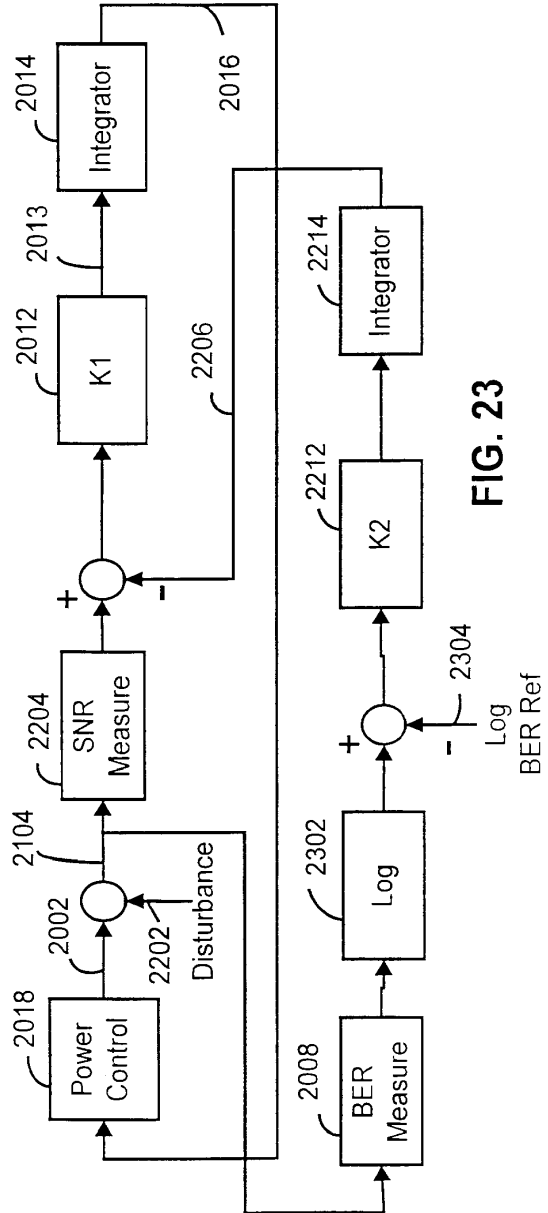


FIG. 23

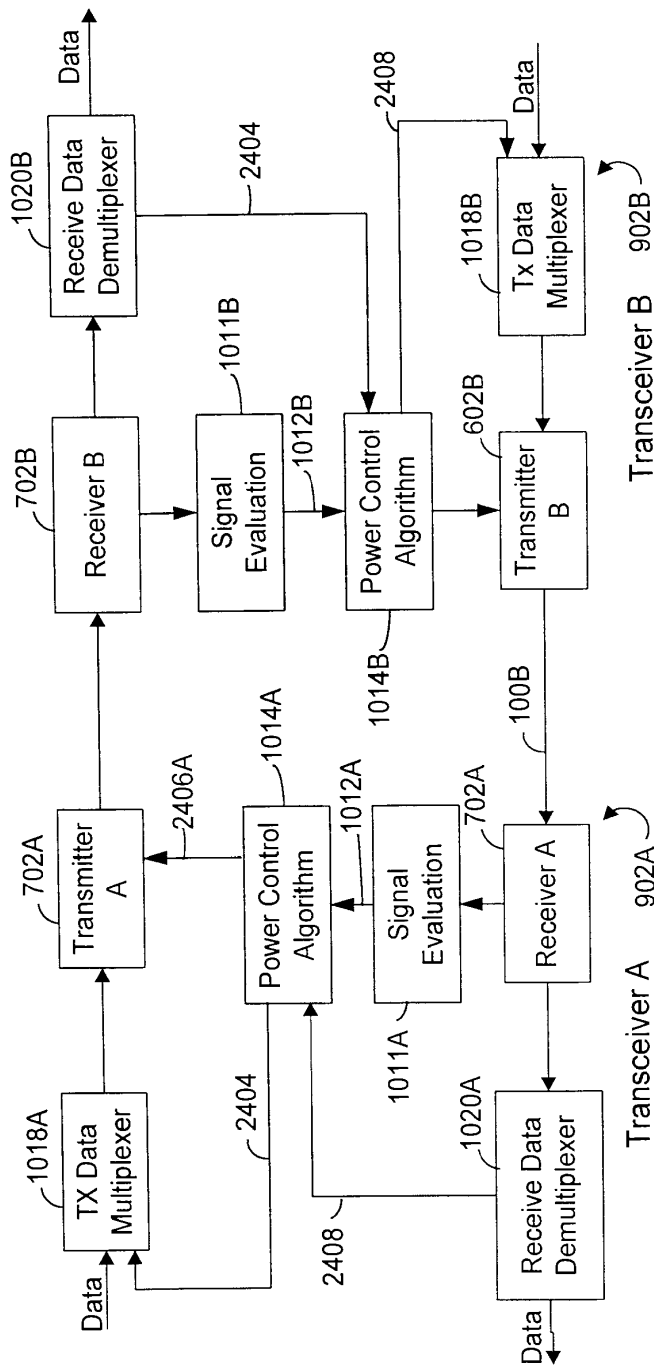


FIG. 24



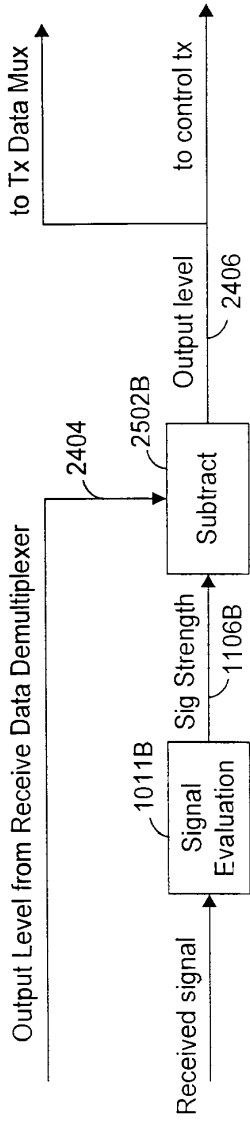


FIG. 25

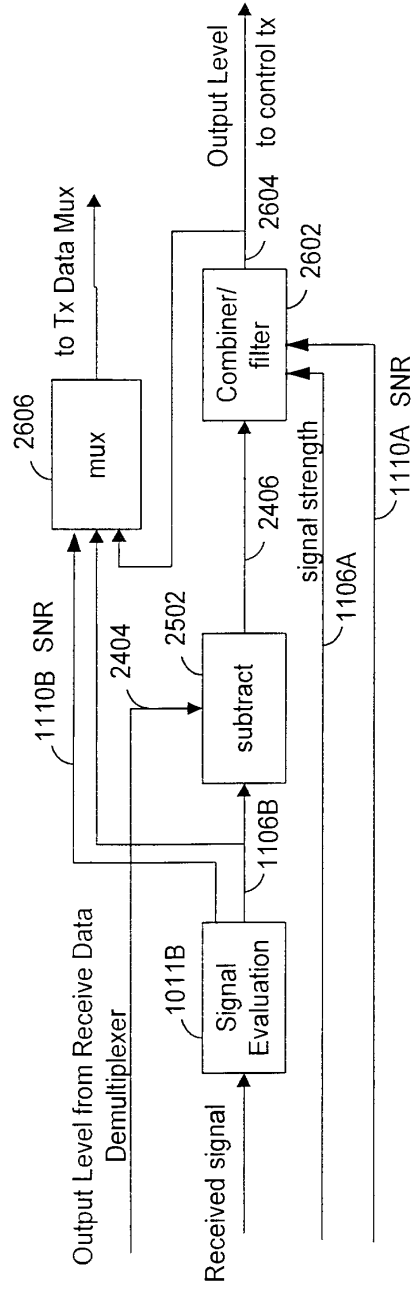


FIG. 26

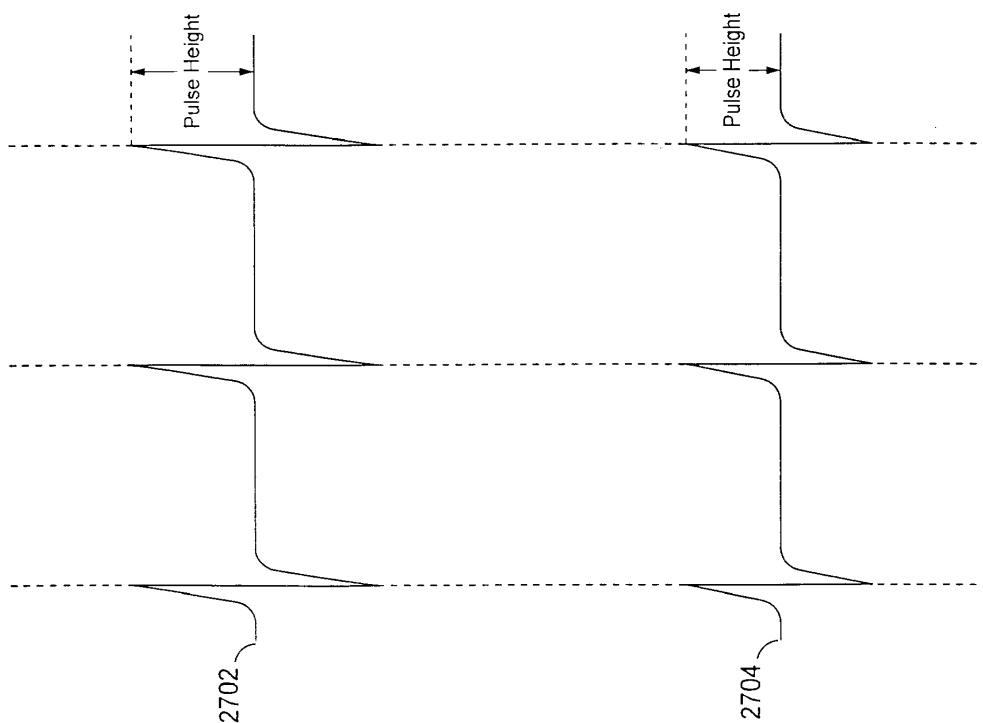


FIG. 27

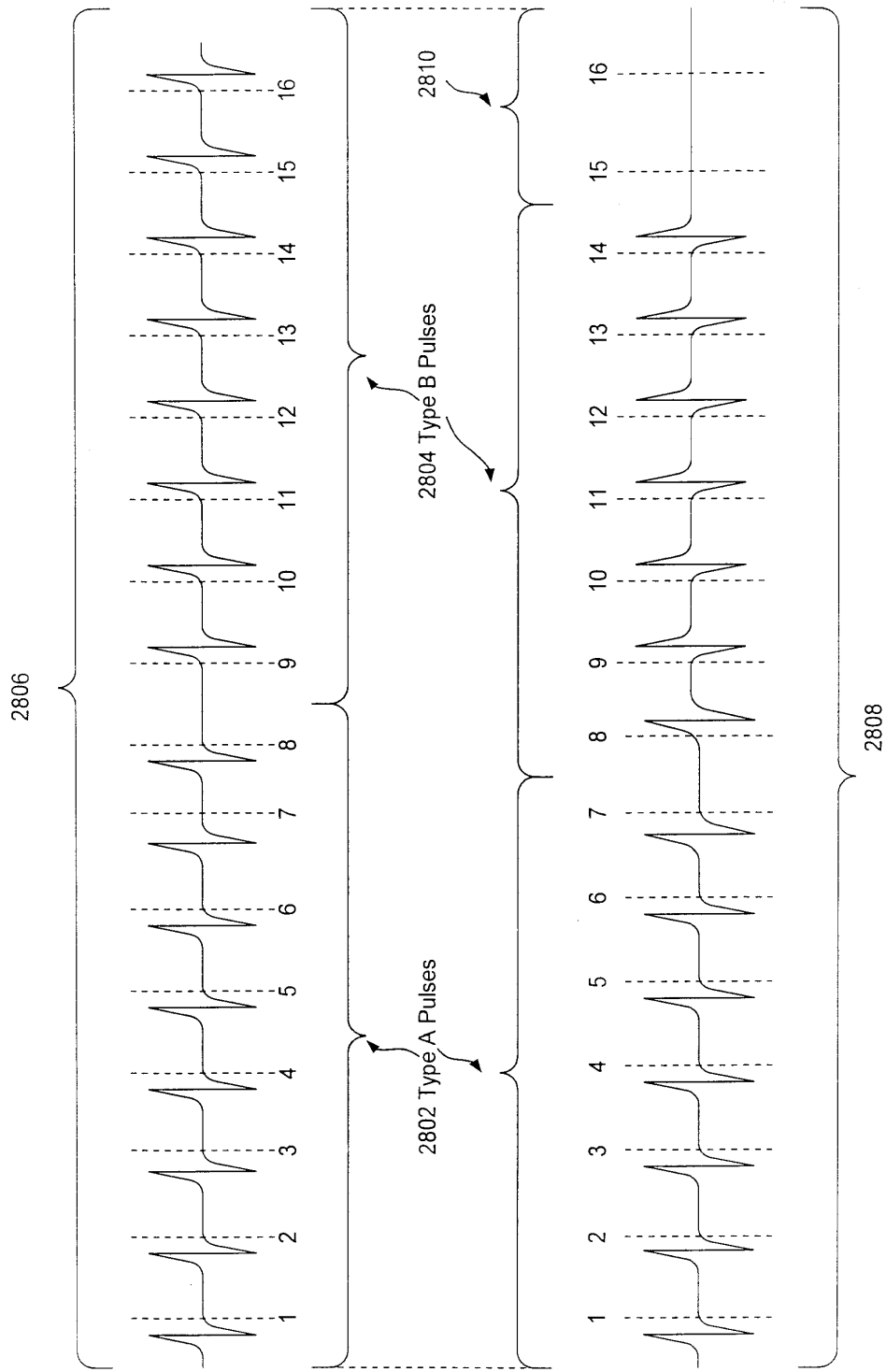


FIG. 28

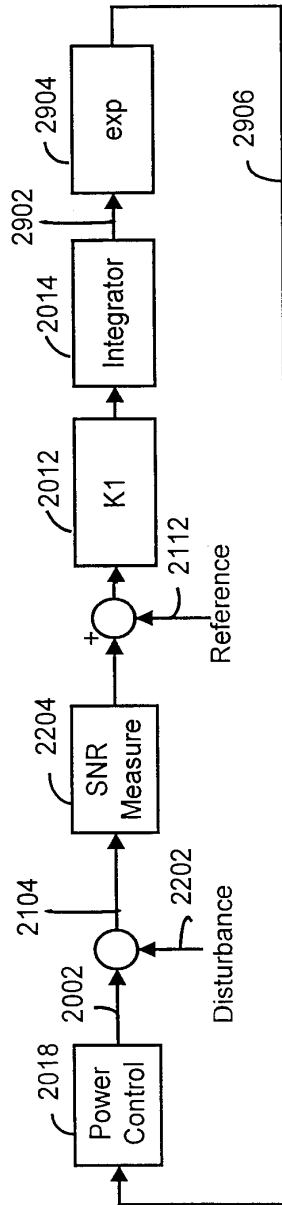


FIG. 29

# INTERNATIONAL SEARCH REPORT

Inte. onal Application No  
PCT/US 00/16084

|   |  |                       |
|---|--|-----------------------|
| <b>A. CLASSIFICATION OF SUBJECT MATTER</b><br>IPC 7 H04B7/005   |  |                       |
| According to International Patent Classification (IPC) or to both national classification and IPC   |  |                       |
| <b>B. FIELDS SEARCHED</b>   |  |                       |
| Minimum documentation searched (classification system followed by classification symbols)<br>IPC 7 H04B   |  |                       |
| Documentation searched other than minimum documentation to the extent that such documents are included in the fields searched   |  |                       |
| Electronic data base consulted during the international search (name of data base and, where practical, search terms used)<br><br>EPO-Internal, WPI Data  |  |                       |
| <b>C. DOCUMENTS CONSIDERED TO BE RELEVANT</b>   |  |                       |
| Category °  | Citation of document, with indication, where appropriate, of the relevant passages   | Relevant to claim No. |
| X   | US 4 777 653 A (BONNEROT GEORGES ET AL)<br>11 October 1988 (1988-10-11)<br>* abstract *<br>column 1, line 45 -column 3, line 9<br>---  | 1,2                   |
| X   | EP 0 853 393 A (NIPPON TELEGRAPH & TELEPHONE) 15 July 1998 (1998-07-15)<br>* abstract *<br>column 1, line 21 -column 2, line 35<br>--- | 1,2                   |
| X   | US 5 758 271 A (RICH RANDALL W ET AL)<br>26 May 1998 (1998-05-26)<br>* abstract *<br>claim 1<br>---                                    | 1,2                   |
| --- /---  |  |                       |
| <input checked="" type="checkbox"/> Further documents are listed in the continuation of box C.  |  |                       |
| <input checked="" type="checkbox"/> Patent family members are listed in annex.  |  |                       |
| ° Special categories of cited documents :   |  |                       |
| "A" document defining the general state of the art which is not considered to be of particular relevance<br>"E" earlier document but published on or after the international filing date<br>"L" document which may throw doubts on priority claim(s) or which is cited to establish the publication date of another citation or other special reason (as specified)<br>"O" document referring to an oral disclosure, use, exhibition or other means<br>"P" document published prior to the international filing date but later than the priority date claimed   |  |                       |
| "T" later document published after the international filing date or priority date and not in conflict with the application but cited to understand the principle or theory underlying the invention<br>"X" document of particular relevance; the claimed invention cannot be considered novel or cannot be considered to involve an inventive step when the document is taken alone<br>"Y" document of particular relevance; the claimed invention cannot be considered to involve an inventive step when the document is combined with one or more other such documents, such combination being obvious to a person skilled in the art.<br>"&" document member of the same patent family |  |                       |
| Date of the actual completion of the international search<br><br>10 October 2000  | Date of mailing of the international search report<br><br>27. 10. 2000   |                       |
| Name and mailing address of the ISA<br>European Patent Office, P.B. 5818 Patentlaan 2<br>NL - 2280 HV Rijswijk<br>Tel. (+31-70) 340-2040, Tx. 31 651 epo nl,<br>Fax: (+31-70) 340-3016  | Authorized officer<br><br>López Márquez, T   |                       |

**INTERNATIONAL SEARCH REPORT**

|   |
|---|
| International Application No<br>PCT/US 00/16084 |
|---|

| C.(Continuation) DOCUMENTS CONSIDERED TO BE RELEVANT |   |                       |
|--|---|-----------------------|
| Category *   | Citation of document, with indication, where appropriate, of the relevant passages  | Relevant to claim No. |
| P, X   | WO 00 04649 A (NOKIA NETWORKS OY ;NAGHIAN<br>SIAMAEK (FI)) 27 January 2000 (2000-01-27)<br>* abstract *<br>page 2, line 26 -page 4, line 2<br>----- | 1, 2                  |

1

# INTERNATIONAL SEARCH REPORT

Information on patent family members

International Application No

PCT/US 00/16084

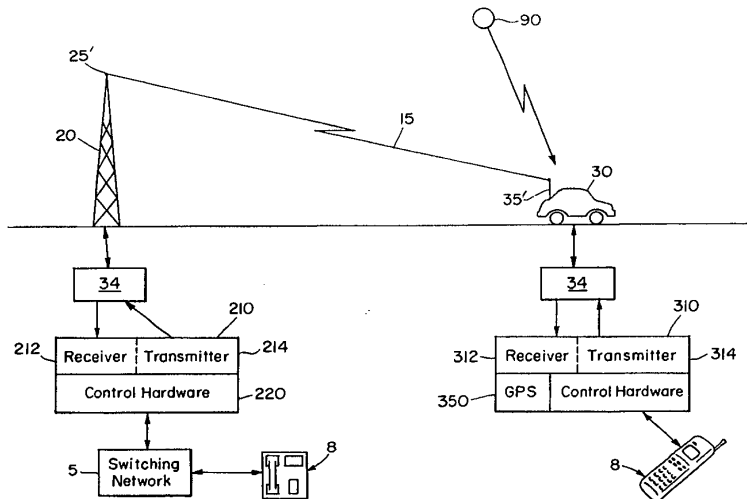
| Patent document<br>cited in search report | Publication<br>date | Patent family<br>member(s) | Publication<br>date |
|---|---------------------|----------------------------|---------------------|
| US 4777653    A                           | 11-10-1988          | FR 2592256 A               | 26-06-1987          |
|   |                     | AU 6665486 A               | 25-06-1987          |
|   |                     | CA 1274281 A               | 18-09-1990          |
|   |                     | DE 3650308 D               | 01-06-1995          |
|   |                     | DE 3650308 T               | 16-11-1995          |
|   |                     | EP 0230691 A               | 05-08-1987          |
|   |                     | FI 865149 A                | 21-06-1987          |
|   |                     | JP 2057680 C               | 23-05-1996          |
|   |                     | JP 7095713 B               | 11-10-1995          |
|   |                     | JP 62157427 A              | 13-07-1987          |
|   |                     | NO 865085 A                | 22-06-1987          |
|   |                     | EP 0853393    A            | 15-07-1998          |
| CN 1198274 A                              | 04-11-1998          |                            |                     |
| WO 9750197 A                              | 31-12-1997          |                            |                     |
| US 5758271    A                           | 26-05-1998          | CA 2175860 A               | 03-12-1996          |
|   |                     | CN 1140938 A               | 22-01-1997          |
|   |                     | JP 8330986 A               | 13-12-1996          |
|   |                     | KR 221163 B                | 15-09-1999          |
| WO 0004649    A                           | 27-01-2000          | FI 981625 A                | 17-01-2000          |
|   |                     | AU 5043699 A               | 07-02-2000          |



INTERNATIONAL APPLICATION PUBLISHED UNDER THE PATENT COOPERATION TREATY (PCT)

|  |                  |   |
|--|------------------|---|
| <p>(51) International Patent Classification <sup>6</sup> :<br/><b>H04Q 7/22, G01S 5/02</b></p>   | <p><b>A2</b></p> | <p>(11) International Publication Number: <b>WO 98/16077</b><br/>(43) International Publication Date: 16 April 1998 (16.04.98)</p>  |
| <p>(21) International Application Number: PCT/US97/18780<br/>(22) International Filing Date: 10 October 1997 (10.10.97)<br/>(30) Priority Data:<br/>08/729,289 10 October 1996 (10.10.96) US<br/>(71) Applicant (for all designated States except US): TERATECH CORPORATION [US/US]; 223-A Middlesex Turnpike, Burlington, MA 01803 (US).<br/>(72) Inventors; and<br/>(75) Inventors/Applicants (for US only): VELAZQUEZ, Scott, R. [US/US]; Ocean Place Tower, 388 Ocean Avenue, No. 1212, Revere, MA 02151-2668 (US). BROADSTONE, Steven, R. [US/US]; 14 Hammond Place, Woburn, MA 01801 (US). CHIANG, Alice, M. [US/US]; 4 Glenfield East, Weston, MA 02193 (US).<br/>(74) Agents: HOOVER, Thomas, O. et al.; Hamilton, Brook, Smith &amp; Reynolds, P.C., Two Militia Drive, Lexington, MA 02173 (US).</p> |                  | <p>(81) Designated States: AL, AM, AT, AU, AZ, BA, BB, BG, BR, BY, CA, CH, CN, CU, CZ, DE, DK, EE, ES, FI, GB, GE, GH, HU, IL, IS, JP, KE, KG, KP, KR, KZ, LC, LK, LR, LS, LT, LU, LV, MD, MG, MK, MN, MW, MX, NO, NZ, PL, PT, RO, RU, SD, SE, SG, SI, SK, SL, TJ, TM, TR, TT, UA, UG, US, UZ, VN, YU, ZW, ARIPO patent (GH, KE, LS, MW, SD, SZ, UG, ZW), Eurasian patent (AM, AZ, BY, KG, KZ, MD, RU, TJ, TM), European patent (AT, BE, CH, DE, DK, ES, FI, FR, GB, GR, IE, IT, LU, MC, NL, PT, SE), OAPI patent (BF, BJ, CF, CG, CI, CM, GA, GN, ML, MR, NE, SN, TD, TG).<br/><br/><b>Published</b><br/><i>Without international search report and to be republished upon receipt of that report.</i></p> |

(54) Title: COMMUNICATION SYSTEM USING GEOGRAPHIC POSITION DATA



(57) Abstract

A wireless communication system employs directive antenna arrays and knowledge of position of users to form narrow antenna beams to and from desired users and away from undesired users to reduce co-channel interference. By reducing co-channel interference coming from different directions, spatial filtering with antenna arrays improves the call capacity of the system. A space division multiple access (SDMA) system allocates a narrow antenna beam pattern to each user in the system so that each user has its own communication channel free from co-channel interference. The position of the users is determined using geo-location techniques. Geo-location can be derived via triangulation between cellular base stations or via a global positioning system (GPS) receiver.



*FOR THE PURPOSES OF INFORMATION ONLY*

Codes used to identify States party to the PCT on the front pages of pamphlets publishing international applications under the PCT.

|    |                          |    |  |    |  |    |                          |
|----|--------------------------|----|--|----|--|----|--------------------------|
| AL | Albania                  | ES | Spain                                    | LS | Lesotho                                      | SI | Slovenia                 |
| AM | Armenia                  | FI | Finland                                  | LT | Lithuania                                    | SK | Slovakia                 |
| AT | Austria                  | FR | France                                   | LU | Luxembourg                                   | SN | Senegal                  |
| AU | Australia                | GA | Gabon                                    | LV | Latvia                                       | SZ | Swaziland                |
| AZ | Azerbaijan               | GB | United Kingdom                           | MC | Monaco                                       | TD | Chad                     |
| BA | Bosnia and Herzegovina   | GE | Georgia                                  | MD | Republic of Moldova                          | TG | Togo                     |
| BB | Barbados                 | GH | Ghana                                    | MG | Madagascar                                   | TJ | Tajikistan               |
| BE | Belgium                  | GN | Guinea                                   | MK | The former Yugoslav<br>Republic of Macedonia | TM | Turkmenistan             |
| BF | Burkina Faso             | GR | Greece                                   | ML | Mali   | TR | Turkey                   |
| BG | Bulgaria                 | HU | Hungary                                  | MN | Mongolia                                     | TT | Trinidad and Tobago      |
| BJ | Benin                    | IE | Ireland                                  | MR | Mauritania                                   | UA | Ukraine                  |
| BR | Brazil                   | IL | Israel                                   | MW | Malawi                                       | UG | Uganda                   |
| BY | Belarus                  | IS | Iceland                                  | MX | Mexico                                       | US | United States of America |
| CA | Canada                   | IT | Italy                                    | NE | Niger  | UZ | Uzbekistan               |
| CF | Central African Republic | JP | Japan                                    | NL | Netherlands                                  | VN | Viet Nam                 |
| CG | Congo                    | KE | Kenya                                    | NO | Norway                                       | YU | Yugoslavia               |
| CH | Switzerland              | KG | Kyrgyzstan                               | NZ | New Zealand                                  | ZW | Zimbabwe                 |
| CI | Côte d'Ivoire            | KP | Democratic People's<br>Republic of Korea | PL | Poland                                       |    |                          |
| CM | Cameroon                 | KR | Republic of Korea                        | PT | Portugal                                     |    |                          |
| CN | China                    | KZ | Kazakistan                               | RO | Romania                                      |    |                          |
| CU | Cuba                     | LC | Saint Lucia                              | RU | Russian Federation                           |    |                          |
| CZ | Czech Republic           | LI | Liechtenstein                            | SD | Sudan  |    |                          |
| DE | Germany                  | LK | Sri Lanka                                | SE | Sweden                                       |    |                          |
| DK | Denmark                  | LR | Liberia                                  | SG | Singapore                                    |    |                          |
| EE | Estonia                  |    |  |    |  |    |                          |

-1-

## COMMUNICATION SYSTEM USING GEOGRAPHIC POSITION DATA

## RELATED APPLICATIONS

This application is a continuation-in-part of U.S. Serial No. 08/729,289 filed on October 10, 1996, the entire teachings of which are incorporated herein by  
5 reference.

## BACKGROUND OF THE INVENTION

At present, the communications spectrum is at a premium, with projected high capacity requirements of Personal Communication Systems (PCS) adding to the problem. Although all modulation techniques for wireless communications suffer  
10 capacity limitations due to co-channel interference, spread spectrum, or Code Division Multiple Access (CDMA), is a modulation technique which is particularly suited to take advantage of spatial processing to increase user capacity. Spread spectrum increases signal bandwidth from R (bits/sec) to W (Hz), where  $W \gg R$ , so multiple signals can share the same frequency spectrum. Because they share the  
15 same spectrum, all users are considered to be co-channel interferers. Capacity is inversely proportional to interference power, so reducing the interference increases the capacity.

Some rudimentary spatial processing can be used to reduce interference, such as using sector antennas. Instead of using a single omnidirectional antenna, three  
20 antennas each with a 120 degree sector can be used to effectively reduce the interference by three, because, on average, each antenna will only be looking at 1/3 of the users. By repeating the communications hardware for each antenna, the capacity is tripled.

- 2 -

Ideally, adaptive antenna arrays can be used to effectively eliminate interference from other users. Assuming infinitesimal beamwidth and perfect tracking, adaptive array processing (AAP) can provide a unique, interference-free channel for each user. This example of space division multiple access (SDMA) allows every user in the system to communicate at the same time using the same frequency channel. Such an AAP SDMA system is impractical, however, because it requires infinitely many antennas and complex signal processing hardware. However, large numbers of antennas and infinitesimal beamwidths are not necessary to realize the practical benefits of SDMA.

SDMA allows more users to communicate at the same time with the same frequency because they are spatially separated. SDMA is directly applicable to a CDMA system. It is also applicable to a time division multiple access (TDMA) system, but to take full advantage of SDMA, this requires monitoring and reassignment of time-slots to allow spatially separated users to share the same time-slot simultaneously. SDMA is also applicable to a frequency division multiple access (FDMA) system, but similarly, to take full advantage of SDMA, this requires monitoring and reassignment of frequency-slots to allow spatially separated users to share the same frequency band at the same time.

In a cellular application, SDMA directly improves frequency re-use (the ability to use the same frequency spectrum in adjoining cells) in all three modulation schemes by reducing co-channel interference between adjacent cells. SDMA can be directly applied to the TDMA and FDMA modulation schemes even without re-assigning time or frequency slots to null co-channel interferers from nearby cells, but the capacity improvement is not as dramatic as if the time and frequency slots are re-assigned to take full advantage of SDMA.

## SUMMARY OF THE INVENTION

Instead of using a fully adaptive implementation of SDMA, exploitation of information on a users' position changes the antenna beamforming from an adaptive problem to deterministic one, thereby simplifying processing complexity.

5 Preferably, a beamformer uses a simple beam steering calculation based on position data. Smart antenna beamforming using geo-location significantly increases the capacity of simultaneous users, but without the cost and hardware complexity of an adaptive implementation. In a cellular application of the invention, using an antenna array at the base station (with a beamwidth of 30 degrees for example) yields an  
10 order of magnitude improvement in call capacity by reducing interference to and from other mobile units. Using an antenna array at the mobile unit can improve capacity by reducing interference to and from other cells (i.e., improving frequency reuse). For beamforming, the accuracy of the position estimates for each mobile user and update rates necessary to track the mobile users are well within the  
15 capabilities of small, inexpensive Global Positioning System (GPS) receivers.

In general, the present invention is a communication system with a plurality of users communicating via a wireless link. A preferred embodiment of the invention is a cellular mobile telephone system. Each user has a transmitter, receiver, an array of antennas separated in space, a device and method to determine  
20 its current location, hardware to decode and store other users' positions, and beamformer hardware. The beamformer uses the stored position information to optimally combine the signals to and from the antennas such that the resulting beam pattern is directed toward desired users and away from undesired users.

An aspect of the invention uses a deterministic direction finding system.  
25 That system uses geo-location data to compute an angle of arrival for a wireless signal. In addition, the geo-location data is used to compute a range for the wireless signal. By using the determined angle of arrival and range, a system in accordance

with the invention can deterministically modify the wireless signal beam between transceivers.

#### BRIEF DESCRIPTION OF THE DRAWINGS

The foregoing and other objects, features and advantages of the invention, including various novel details of construction and combination of parts will be apparent from the following more particular drawings and description of preferred embodiments of the communication system using geographic position data in which like reference characters refer to the same parts throughout the different views. It will be understood that the particular apparatus and methods embodying the invention are shown by way of illustration only and not as a limitation of the invention, emphasis instead being placed upon illustrating the principles of the invention. The principles and features of this invention may be employed in various and numerous embodiments without departing from the scope of the invention.

FIG. 1 is a schematic diagram of a cellular communication system.

FIG. 2 is a schematic block diagram of components in a base station and a mobile unit of FIG. 1.

FIG. 3 is a schematic diagram of a general adaptive antenna array.

FIG. 4 is a schematic diagram of a mobile-to-base communications link in cellular communications using AAP SDMA.

FIG. 5 is a schematic diagram of a base-to-mobile communications link in cellular communications using AAP SDMA.

FIG. 6 is a schematic diagram of a general SDMA communications system employing geo-location techniques.

FIG. 7 is a schematic block diagram of two communicating users of FIG. 6.

FIG. 8 is a flow chart of a method of operating a cellular telephone system using geo-location data.

- 5 -

FIG. 9 is a schematic diagram of a cellular telephone system using geo-location data.

FIG. 10 is a schematic block diagram of a steering circuit.

FIG. 11 is a schematic block diagram of a nulling circuit.

5 FIG. 12 is a schematic block diagram of a receiver module for a mobile unit beamformer.

FIG. 13 is a schematic block diagram of a transmitter module for a mobile unit beamformer.

10 FIG. 14 is a schematic block diagram of a receiver module for a base station beamformer.

FIG. 15 is a schematic block diagram of a transmitter module for a base station beamformer.

FIG. 16 is a schematic block diagram of a preferred base station employing real-valued FIR filtering at IF.

15 FIG. 17 is a schematic block diagram of a preferred base station employing complex-valued FIR filtering at base band.

FIG. 18 is a schematic block diagram of a beamshaping circuit based on an adaptive-array processing algorithms.

#### DETAILED DESCRIPTION OF PREFERRED

#### 20 EMBODIMENTS OF THE INVENTION

FIG. 1 is a schematic diagram of a general land-based cellular wireless communications system. The geographic area serviced by this communications system 1 is divided into a plurality of geographic cells 10, each cell 10 having a respective geographically fixed base station 20. Each cell 10 can have an arbitrary  
25 number of mobile cellular units 30, which can travel between and among the cells 10.

FIG. 2 is a schematic block diagram of components in a base station 20 and a mobile unit 30 of FIG. 1. As shown, each base station 20 includes a transceiver 210 having a transmitter 212 and a receiver 214, control hardware 220, and a set of antennas 25 to communicate with a plurality of mobile units 30. The mobile units 5 are free to roam around the entire geographic service area. Each mobile unit 30 includes a transceiver 310 having a transmitter 312 and a receiver 314, control hardware 320, a handset 8, and an antenna or antennas 35 to allow for simultaneous sending and receiving of voice messages to the base station 20. The base station 20 communicates with a mobile telecommunications switching office (MTSO) 5 to route 10 the calls to their proper destinations 2.

The capacity of a spread spectrum cellular communication system can be expressed as:

$$N = (W/R) (N_0/E_b) (1/D) F G$$

where W is the bandwidth (typically 1.25 MHz);

R is the data rate (typically 9600 bps);

15  $E_b/N_0$  is the energy-to-noise ratio (typically 6 dB);

D is the voice duty-cycle (assumed to be 0.5);

F is the frequency reuse (assumed to be 0.6);

G is the number of sectors per cell (assumed to be 1, or omnidirectional); and

20 N is the number of simultaneous users.

As such, a typical cell can support only about 25-30 simultaneous calls. Space division multiple access (SDMA) techniques can be used to increase capacity.





For the base-to-mobile link, the co-channel interferers are the neighboring base stations. Conceivably, the number of antennas in the adaptive array at the mobile could be approximately the same as the number of neighboring base stations, so subspace methods of direction-of-arrival estimation may be applicable to null out the interfering base stations. The computational complexity of both types of AAP algorithms is approximately equal.

The majority of the computational complexity incurred by using AAP in a cellular system is due to covariance formulation and copy processing. The covariance is a sum of a sequence of matrices, each of which is an outer product of complex array samples. Each term of this outer product is a complex product. The computation requires on the order of  $K^2$  computations, where  $K$  is the number of antennas. Using the covariance, the AAP algorithm computes the antenna weight vector, which is applied to the received signal vectors. This is a matrix inversion, which copies the desired signal. The covariance is updated periodically, and each desired signal is copied in real time.

Overall about 1/2 to 2/3 of the computational complexity incurred by using AAP SDMA in a cellular system is due to the covariance formulation alone, and the remaining complexity resides in the matrix inversion for copy weight generation. The complexity, size, power consumption, and cost of implementing AAP SDMA has thus far prevented it from gaining acceptance. In preferred embodiments, the present invention achieves substantially the same results as a fully adaptive implementation of SDMA but with significantly less hardware complexity, smaller size, lower power consumption, and lower cost.

FIG. 4 is a schematic diagram of a mobile-to-base communication link in a cellular communications system using AAP SDMA. Illustrated are the antenna array SDMA transmission beam patterns 150 from the mobile units 30 to the base station 20 along a central direction 155. Also illustrated is interference 170 which would exist without SDMA.

Assuming the base station 20 employs a multi-antenna adaptive array while the mobile unit 30 uses a single omnidirectional antenna, in the reverse channel (uplink, or mobile-to-base), the base station array reduces interference from other users both in-cell and out-of-cell, as illustrated in FIG. 4, by pointing its reception  
5 beam only towards the desired mobile unit 30.

For a 120 degree beamwidth, about 1/3 of the mobile units 30 in a cell 10 are visible to the array, so the capacity is approximately tripled. Similarly, for a 30 degree beamwidth, about 1/12 of the mobile units 30 in a cell 10 are visible to the array, so the capacity is increased by a factor of approximately 12.

10 Assuming that both the base station 20 and the mobile unit 30 employ multi-element antenna arrays, for the reverse channel, this system significantly reduces interference from out-of-cell mobile transmitters, because they are forming beams toward their own base station 20. Ideally, this would improve the frequency reuse,  $F$ , from 0.6 to nearly 1.0, thereby increasing the capacity by nearly 2/3.  
15 Simulations on such a system show that a frequency re-use factor of  $F = 0.8826$  with a 60 degree beamwidth from the mobile unit improves capacity by 47% over the omnidirectional case ( $F = 0.6$ ).

Improvement due to adaptive arrays on the mobile units 30 are not as dramatic as those achieved with adaptive arrays at the base station 20. In addition,  
20 complexity, size, power, and cost can make the application of antenna arrays in mobile units 30 impractical for most situations. The reduction in inter-cell interference afforded by adaptive arrays in mobile units 30 may, however, be critical in high-traffic environments and for mobile units 30 near the cell boundaries where interference is the greatest.

25 FIG. 5 is a schematic diagram of a base-to-mobile communication link in a cellular communications system using AAP SDMA. Assuming the base station 20 employs a multi-antenna array while the mobile unit 30 uses a single omnidirectional antenna, in the base-to-mobile link, the base station 20 antenna array reduces

interference to other users both in-cell 180 and out-of-cell 175, as illustrated in FIG. 4. Results for this channel for various beamwidths are summarized below in Table II.

Table II

5 Base Station Antenna Beamwidth vs. Call Capacity in Base-to-Mobile Channel

| Beamwidth (degrees) | Capacity (calls\cell) |
|---------------------|-----------------------|
| 360 (omni)          | 30                    |
| 75 (5 antennas)     | 120                   |
| 55 (7 antennas)     | 165                   |

10 Assuming that both the base station 20 and the mobile units 30 employ multi-element adaptive antenna arrays, for the forward channel, this system significantly reduces interference from out-of-cell base stations, because the mobile units 30 are forming beams toward their own base station 20. As in the reverse channel, ideally, this would improve the frequency re-use, F, from 0.6 to nearly 1.0, thereby  
 15 increasing the capacity by nearly 2/3.

FIG. 6 is a schematic diagram of a general SDMA communications system employing geo-location techniques. As illustrated, a first user 301 and a second user 302 are in communication. The first user 301 computes the direction of the desired user 302 and a beam pattern 314 is formed along the desired direction 316.  
 20 In addition to desired users 302, the first user 301 wants to avoid projecting a beam in the direction 317 of an undesired user 303. Furthermore, the first user 301 wants to avoid receiving a beam from any direction other than the desired direction 316. These goals are accomplished by utilizing a narrow directional radio beam.

- 11 -

The radio-beam extends from the transmitting unit at a beamwidth angle  $B_0$ . The distance from the transmitting unit to the receiving unit is designated as  $r_m$ . The beamwidth at the receiving unit is  $B_m$ . In a cellular system, a base unit is located at the center of a geographical cell of radius  $R$  and the receiving unit is  
5 generally mobile and moves with a velocity  $V$ .

FIG. 7 is a schematic block diagram of communicating users of FIG. 6. As illustrated, the first user 301 and the second user 302 receive geo-location data from a satellite system 90. The users 301, 302 communicate using a respective antenna array 52 controlled by a respective beamformer circuit 34. In addition to the  
10 standard transceiver 310 and control hardware 320, a Global Positioning System (GPS) circuit 350 communicates with a global positioning satellite system 90 to command the beamformer 34. Although a satellite system 90 is illustrated, the geo-location data can be provided by or derived from a ground-based positioning system. Furthermore, a differential global positioning system using both ground and satellite  
15 based transmitters can be employed to provide a higher resolution location.

FIG. 8 is a flow chart of a method of operating a cellular telephone system using geo-location data. As a part of the initial establishment of the wireless link (step 500) between the mobile unit 30 and the base station 20, the mobile unit 30 must determine its current position. The GPS receiver may not already be tracking  
20 satellites and could take several minutes to get an accurate position estimate (cold start). If the GPS receiver 350 is cold starting (step 510), the base station 20 provides a rough location estimate to orient the GPS receiver and significantly expedite the position acquisition (step 512). It can send an estimate of the mobile unit's location via triangularization from adjacent base stations. This information  
25 can be sent along with a Channel Assignment Message (which informs the mobile unit of a Traffic Channel on which to send voice and data) via a Paging Channel. Users share the Paging Channel to communicate information necessary for the establishment of calls.

- 12 -

Then the base station 20 transmits its position to the mobile unit 30 via the Paging Channel (Step 520). If the mobile unit 30 is employing a directive antenna array 35', it uses the base station position and its current position and heading information to form a beam pattern toward the base station 20 as described above  
5 (step 530). The mobile tunes to the Traffic Channel and starts sending a Traffic Channel preamble and the current mobile location information to the base station via a Reverse Traffic Channel (step 540). Every two seconds, the GPS location is updated and sent to the base station via the Reverse Traffic Channel.

If the mobile unit 30 is employing a directive antenna array 35', every two  
10 seconds it uses the current heading information and compares its updated position information to the stored location of the current base station to update the beam pattern toward the base station. Also, the base station 20 receives the updated mobile unit location information and updates its beam pattern toward the mobile unit (step 550). During hand-off between base stations (step 560), the directivity of the  
15 mobile antenna array, if employed, is disabled (step 570) to allow the user to communicate with other base stations.

FIG. 9 is a schematic diagram of a cellular telephone system using geo- location data. A preferred embodiment is an implementation of SDMA using knowledge of user position in a cellular spread spectrum communication system.  
20 Fixed base stations 20 communicate with roving mobile units 30 within a prescribed geographic cell 10. Each base station 20 consists of a transceiver 210, a directional antenna array 25' and associated beamformer hardware 24, control hardware 220, and a transmission link with a mobile telecommunications switching office (MTSO)  
5 to route calls. The mobile unit 30 consists of handset 8 with a microphone and a  
25 speaker, a transceiver 310, a GPS receiver 350 (or other hardware to determine position of the mobile), and an omnidirectional antenna 35 or optionally a directional antenna array 35' and associated beamformer hardware 34.

- 13 -

A preferred embodiment of the invention employs a conventional CDMA base station 20 but with the addition of a 10-element directional antenna array 25' capable of forming antenna patterns with a beamwidth of 36 degrees, beamformer hardware 24, and additional modems to accommodate the order of magnitude  
5 increase in call capacity. The beamformer hardware 24 takes as input the current latitude and longitude of each mobile unit, compares it with the known location of the base station 20 to determine the angle of arrival (AOA) of each mobile unit's signal, and generates a set of complex antenna weights to apply to each antenna  
10 output for each mobile unit such that the combined signal represents a beam pattern steered in the direction of the desired mobile unit for both the transmit and receive signals. The complex antenna weights are calculated to simply steer the antenna beam.

Instead of calculating the weights in real-time, a set of weights can be stored in a Programmable Read-Only Memory (PROM) for a finite set of angles of arrival,  
15 and can be recalled and immediately applied. The beam pattern is preferably widened as the mobile unit 30 approaches the base station 20 (as described below) because the beam coverage decreases as the mobile unit 30 approaches the base station 20. Furthermore, the assumption that multipath components propagate from approximately the same location as the mobile unit 30 becomes less valid as the  
20 mobile unit 30 approaches the base station. Optionally, the beamformer hardware 24 can track multiple mobile units simultaneously and place nulls on interfering mobile units, but this is more computationally complex (although not as complex as a fully adaptive array).

The base station antenna array forms an antenna pattern with beamwidth  
25  $B_0=30$  degrees. Assuming the cell radius is  $R=6$  km, the mobile unit is at radius  $r_m$  (m), the maximum velocity of the mobile unit is  $V=100$  (km/h), and the location estimate is updated at  $U=2$  times per second, examination of the pie-slice geometry of the antenna pattern reveals that the antenna beam width at the mobile unit's

location is  $B_m = 2\pi r_m(B_0/360)$  meters, which decreases as the mobile unit 30 approaches the base station 20. Once a location estimate has been determined for the mobile unit 30 and transmitted to the base station 20, the base station 20 forms an antenna pattern with the main lobe centered on the mobile unit 30.

5 In the worst case, this estimate is wrong by  $T=30$  m. In an update cycle, the mobile travels  $V/U$  (m), and as long as this distance is less than  $B_m/2$  (half the beamwidth in meters at the mobile location) minus the error in the location estimate,  $T$ , then the mobile will remain within the antenna main lobe:  $V/U \leq (B_m/2)-T$ . Evaluating this equation with the typical numerical values and solving for the mobile  
10 location yields  $r_m \geq 167.6$  m at a velocity  $V=100$  km/h. Therefore the mobile unit 30 remains in the beam coverage area as long as it is further than 167.6 m from the base station 20.

The base station 20 uses the location information to sense when the mobile unit 30 is closer than 167.6 m and widens the beam pattern to omnidirectional (or  
15 optionally to 120 degrees). This widening does not significantly increase interference to other users because the low power is used for nearby mobile units 30. The complex antenna weights for the widened beams are preferably stored in memory for a finite set of angles of arrival, and they can be recalled and immediately applied.

20 The mobile units 30 include a conventional handset 8 preferably augmented with an integrated GPS receiver 350 and modifications to the control logic 320 to incorporate the GPS position data in the transmission to the base station 20. Mobile units 30 embodied in automobiles preferably employ a three-element directional antenna array 35' mounted on the automobile and beamformer hardware 34 in  
25 addition to the handset with the built-in GPS receiver as described above. The beamformer hardware 34 stores the current base station's latitude and longitude, compares it with its own current latitude and longitude, and computes its current heading via GPS doppler information to determine the angle of the arrival of the

base station signal. A look-up table (for example in a ROM) provides the antenna weights to steer the transmit and receive beam pattern toward the base station. Optionally, the beamformer hardware can track multiple base stations simultaneously and place nulls on interfering base stations.

5           The necessary accuracy of the mobile position determination depends on the width of the antenna beam. Assuming the location can be determined to within a tolerance of  $T=30$  m (i.e., the location can be determined with high probability to be within a circle of radius  $T=30$  m), as the mobile unit 30 moves, the antenna beam must cover the entire area in which the mobile unit 30 can move in the two  
10 seconds before the position is checked again and the antenna beam pattern is updated. Because of the pie-slice geometry of the beam pattern, as the mobile unit 30 approaches the base station 20, the beam coverage decreases and must be widened to cover the area in which the mobile unit 30 could travel in the two second update cycle.

15           Mobile units employing the antenna array 35' can form an antenna pattern with beamwidth  $B_1 = 120$  degrees. Assuming the cell radius is  $R=6$  km, the mobile is at radius  $r_m$  (meters), the maximum rotation of the mobile unit is  $\Omega=45$  degrees/second (i.e., the mobile can turn a 90 degree corner in 2 seconds), and the location estimate is updated at  $U=2$  times per second, examination of the pie-slice  
20 geometry of the antenna pattern yields a location tolerance at the base station of  $T_b = 360T/(2\pi\Omega r_m)$  (degrees), which increases as the mobile unit 30 approaches the base station 20.

In addition to location, the mobile unit 30 needs to know its direction of travel so it can determine the orientation of its antenna array. This direction vector  
25 can be deduced from GPS doppler data or from a compass.

Once a location estimate has been determined, the mobile unit 30 forms an antenna pattern with the main lobe centered on the base station 20. In the worst case, this estimate is wrong by  $T_b$  (degrees) and the mobile unit 30 is turning at



- 16 -

maximum rotation  $\Omega=45$  degrees/s. In an update cycle, the mobile's main lobe rotates  $\Omega/U$  (degrees), and as long as this angle is less than  $B_1/2$  (half the mobile beamwidth in degrees) minus the error in the location estimate,  $T_b$  (degrees), then the base station 20 will remain within the mobile antenna's main lobe,

- 5  $\Omega/U \leq (B_1/2)-T_b$ . Evaluating this equation with the numerical values above and solving for the mobile location yields  $r_m \geq 45$  m. Therefore the base station 20 remains in the beam coverage area as long as it is further than 45 m from the mobile unit 30.

The mobile unit 30 uses its location information to sense when it is closer  
10 than 45 m to the base station 20 and widens the beam pattern to omnidirectional. Again, this widening does not significantly increase interference to other users because the power transmitted is low. A look-up table in a ROM provides the antenna weights to change the beam pattern to omnidirectional when the mobile unit 30 is within 45 m of the beam station or during call hand-off when the mobile unit  
15 30 is communicating with more than one base station 20.

A preferred embodiment of the invention includes an aspect which reduces interference and improves capacity as long as the multipath components propagate from approximately the same direction as the line-of-sight (LOS) component, which is a fair assumption. Typically, a multipath signal is limited to a  $5-10^\circ$  arc relative  
20 to the receiver. As such, various techniques can be employed to identify and null the multipath component of a received signal.

Aspects of the invention can be practiced even if some users are not equipped with SDMA capability. In the case that a particular user does not employ an antenna array, the user will not use position information and will default to  
25 conventional omnidirectional transmission and/or reception. Similarly, in the case that the user does not provide position information, other users will default to conventional omnidirectional transmission to and/or reception from that user. As conventional users are phased out and SDMA equipped users are phased in, the

- 17 -

capacity of the system will increase as the fraction of SDMA equipped users increases.

FIG. 10 is a schematic block diagram of a steering circuit. The steering circuit 52 includes a GPS receiver 522 connected to a GPS antenna 520 for receiving GPS signals from satellites. The GPS receiver 522 computes the unit's latitude and longitude. A deterministic direction finder 524 processes the mobile unit latitude  $LAT_M$  and longitude  $LNG_M$  data as well as the base station latitude  $LAT_B$  and longitude  $LNG_B$  data using a first look-up table to compute an angle of arrival (AOA) and a range (RNG) based on the following equations:

$$AOA = \tan^{-1} \left[ \frac{LNG_M - LNG_B}{LAT_M - LAT_B} \right]$$

$$RNG = \sqrt{(LAT_M - LAT_B)^2 + (LNG_M - LNG_B)^2}$$

The AOA and RNG values are processed by a second look-up table in an antenna steering unit 526 which converts the values into antenna weights. The antenna weights are calculated to steer the beam in the direction of the angle of arrival. That is, the antenna weights become unity (i.e., omnidirectional) when the range is below a prescribed threshold (i.e., the mobile unit is very close to the base station) and for the mobile unit during handoff. The antenna weights are provided to the beamformer.

FIG. 11 is a schematic block diagram of a nulling circuit. Position data from each user is processed by a GPS circuit  $521_a, \dots, 521_k$ . For a particular user "a", a desired latitude  $LAT_{Ma}$  and longitude  $LNG_{Ma}$  data are received and for other users undesirable latitude  $LAT_{Mb}, \dots, LAT_{Mk}$  and longitude  $LNG_{Mb}, \dots, LNG_{Mk}$  data are received. A first look-up table in a deterministic direction finder unit 523 converts the latitude and longitude data from the mobile units into desired  $AOA_a$  and undesired  $AOA_b, \dots, AOA_k$  angles of arrival and a desired range RNG based on the

base station latitude  $LAT_B$  and longitude  $LNG_B$  data. This information for each user is passed to a second look-up table in a nulling unit 525 which computes antenna weights which are calculated to steer the beam in the direction of the desired angle of arrival  $AOA_a$  and away from the undesired angle of arrivals

- 5  $AOA_b, \dots, AOA_k$  (i.e., a circuit nulls undesired users). The antenna weights can become unity as described above. The antenna weights from the nulling unit 525 are provided to the beamformer.

FIG. 12 is a schematic block diagram of a receiver module for a mobile unit beamformer. The circuit receives a plurality of RF signals  $IN_a, IN_b, IN_c$  over a  
10 respective antenna 35'a, 35'b, 35'c of a directional antenna array 35'. The RF signals are processed into three baseband signal channels by a three-channel receiver 312. Each baseband signal is processed by a programmable filter 342a, 342b, 342c. A GPS signal from a GPS receiver (not shown) is received by a steering/nulling  
15 circuit 344 operating as described above. The steering/nulling circuit 344 controls the programmable filters 342a, 342b, 342c. The outputs from the programmable filters are combined by a RF combiner 346 to produce an output signal OUT.

FIG. 13 is a schematic block diagram of a transmitter module for a mobile unit beamformer. The input signal IN is split three ways and processed by  
20 respective programmable filters 341a, 341b, 341c. The programmable filters 341 are controlled by a steering/nulling circuit 343 based on inputs from a GPS receiver (not shown) as described above. Three channels of baseband signals result from the programmable filters and are fed to a three-channel transmitter 314 which sends RF  
25 signals  $OUT_a, OUT_b, OUT_c$  to a respective antenna 35'a, 35'b, 35'c in the antenna array 35'. In a preferred embodiment of the invention, the system implements programmable filtering by including a vector-matrix product processing system as described in U.S. Patent No. 5,089,983 to Chiang, the teachings of which are incorporated herein by reference.

FIG. 14 is a schematic block diagram of a receiver module for a base station beamformer. As illustrated, the antenna array 25' of the base station includes 10 antennas  $25'_1, \dots, 25'_{10}$ . The input signals  $IN_1, \dots, IN_{10}$  are received by a ten-channel receiver 212 which yields ten channels of baseband signals. Each channel of  
5 baseband signal is processed by a programmable filter array 242, each of which includes a respective programmable filter for each of N possible users. The programmable filters 242 are controlled by a steering/nulling circuit 244 for each user based on GPS data received from each user as described above. The outputs from the programmable filters 242 are combined by an RF combiner 246 into N  
10 outputs OUT.

FIG. 15 is a schematic block diagram of a transmitter module for a base station beamformer. The transmitter section receives an input signal IN which is split ten ways into ten channels. Each channel is processed by a programmable filter array 241 having a programmable filter for each N possible users. The  
15 programmable filters are controlled by a steering/nulling circuit 243 for each user based on GPS data from each mobile user as described above. The programmable filters yield N baseband signals divided into ten channels which are transmitted to the antenna array 25' by a ten-channel transmitter 214. Each antenna  $25'_1, \dots, 25'_{10}$  receives a respective RF output signal  $OUT_1, \dots, OUT_{10}$  from the transmitter 214.

20 In a preferred embodiment of the invention, a cellular base station includes sufficient signal-processing hardware to support the use of geo-location information, received from mobile transmitters, to optimally shape the receiving antenna-array pattern. This approach is an alternative to using a fully adaptive antenna-array that requires a significantly greater cost in terms of hardware and software.

25 To implement a fully-adaptive base station receiver, an array of antenna inputs must be processed to yield a set of complex-valued weights that are fed back to regulate the gain and phase of the incoming signals. The need for multiple weights applied to a single input signal implies frequency independence. The weight

- 20 -

or weights are applied to each input signal as either a real-valued Finite Impulse Response (FIR) filter at a chosen intermediate frequency (IF) (as depicted in FIG. 16 below) or as complex-valued FIR filter at base band (as depicted in FIG. 17 below). Following the application of the appropriate weights, the outputs from each antenna-channel are summed to yield a beamformed output from the array.

FIG. 16 is a schematic block diagram of a preferred base station employing real-valued FIR filtering at IF. In particular, the base station 1020 employs a sample-data beam shaping system for downconverted and band limited signals. The mobile unit 30 communicates with the base station 1020 through a plurality of N receiver units 1010<sub>1</sub>, 1010<sub>2</sub>, ..., 1010<sub>N</sub>. Each receiver includes a respective antenna 1022<sub>1</sub>, 1022<sub>2</sub>, ..., 1022<sub>N</sub>. Received signals are transmitted from the antennas 1022<sub>1</sub>, 1022<sub>2</sub>, ..., 1022<sub>N</sub> through a bandpass filter, 1024<sub>1</sub>, 1024<sub>2</sub>, ..., 1024<sub>N</sub>; a gain controllable amplifier 1026<sub>1</sub>, 1026<sub>2</sub>, ..., 1026<sub>N</sub>; a multiplier 1028<sub>1</sub>, 1028<sub>2</sub>, ..., 1028<sub>N</sub>; and a second bandpass filter 1030<sub>1</sub>, 1030<sub>2</sub>, ..., 1030<sub>N</sub> to form N receiver output signals.

The receiver output signals are input to a processing chip 1040 which includes a sampling circuit 1042<sub>1</sub>, 1042<sub>2</sub>, ..., 1042<sub>N</sub> and a programmable FIR filter 1044<sub>1</sub>, 1044<sub>2</sub>, ..., 1044<sub>N</sub> for each input signal. The outputs of the FIR filters are summed by a summing circuit 1046. A postprocessor 1048 communicates with an off-chip automatic gain control (AGC) circuit 1032 to provide a control signal to the amplifiers 1026<sub>1</sub>, 1026<sub>2</sub>, ..., 1026<sub>N</sub> to vary the amplifier gains.

The postprocessor 1048 also communicates with an off-chip geo-location controller 1038 which provides geo-location data to a weighted circuit 1046. The weighting circuit 1036 provides weights to the on-chip programmable filters 1044<sub>1</sub>, 1044<sub>2</sub>, ..., 1044<sub>N</sub>.

FIG. 17 is a schematic block diagram of a preferred base station employing complex-valued FIR filtering at base band. As with FIG. 16, the base station 1020 includes a plurality of receivers that provides an input signal to a processing chip

- 21 -

1050. The processing chip 1050 yields two channels of output to an off-chip postprocessor 1034 which decodes, encodes and equalizes the channels. The postprocessor 1034 transmits a signal to the AGC circuit 1032 to control the receiver amplifiers 1026<sub>1</sub>, ..., 1026<sub>N</sub> and is in communication with the geo-location controller 1038. Geo-location data from the geo-location controller 1038 is processed by a weight-update circuit 1036' to calculate weights for a 2N M stage FIR filter array.

The base station includes a beamshaping circuit using a two channel downconversion system. The processing chip 1050 includes, for each of N receivers, a sampling circuit 1052<sub>1</sub>, ..., 1052<sub>N</sub> and a multiplier 1054<sub>1</sub>, ..., 1054<sub>N</sub>. The multipliers 1054<sub>1</sub>, ..., 1054<sub>N</sub> each provide an in-phase (I) channel 1056<sub>1</sub>-I, ..., 1056<sub>N</sub>-I and a quadrature (Q) channel 1056<sub>1</sub>-Q, ..., 1056<sub>N</sub>-Q. The respective channels are passed to respective low pass filters 1058<sub>1</sub>-I, ..., 1058<sub>N</sub>-Q. Each channel is then down-converted by downconversion circuit 1060<sub>1</sub>-I, ..., 1060<sub>N</sub>-Q. The down-converted channels are fed to respective programmable FIR filters 1062<sub>1</sub>-I, ..., 1062<sub>N</sub>-Q. These filters are programmed based on the weight inputs from the weighting circuit 1038. The I and Q channels are individually summed at summing circuits 1064-I, 1064-Q for output to the postprocessing system 1034.

The effect of the weights is to electronically shape the antenna-array response. Ideally, mobile transmitters that are interfering with the desired user are suppressed or nulled out, while the transmitter of interest is given at least unity gain. Using a fully adaptive antenna array, the weights are updated with time as the mobile unit moves or as propagation conditions change. The update of the weights, however, is computationally intensive requiring the computation of the covariance matrix of the array response.

In comparison, a preferred base station uses position information obtained from the mobile transmitter (or from the base-station network) to automatically compute the weights to be applied to the input signals from each antenna. As in the

- 22 -

fully-adaptive system, the weights are updated as the mobile transmitter moves. The potential difficulty with this approach is that it does not explicitly account for changes in the propagation conditions between the mobile transmitter and the base station.

5           In an effort to characterize the propagation conditions between a mobile transmitter and a base station, a series of operations were performed using a fully operational digital-TDMA cellular system. The base station comprised 6 receiving antennas that can be located with arbitrary spacings. A single, mobile transmitter is used to characterize the propagation conditions. Based on the signals received at the  
10 base station, profiles of the signal-propagation delay versus time are mathematically computed. Using these results, the worst case angle-of-arrival is computed. For this case, the delayed signal is assumed to arrive from a reflector along a line perpendicular to a line joining the base station and the mobile.

          For geo-location-based array-processing to operate, the true location of the  
15 transmitter is preferably very close to the angle of arrival (AOA) of the primary propagation path from the mobile.

          When the true location and the AOA of the primary propagation path differ, the beam pattern produced by geo-location information will not exactly produce the desired gain and nulling of the mobiles' signal. This condition produces suppression  
20 of the undesired mobile's signal, but may not completely cancel or null out the transmission.

          For worst-case propagation conditions, this implies that the electronically synthesized beam pattern does not provide the optimal gain for receiving this mobile, nor does it completely null out the undesired signals. The difference  
25 between the ideal (fully adaptive) array beam pattern and one constructed using only geo-location information is not too great, however, when the true position of the mobile and the AOA of the primary propagation path vary by less than a few degrees.

In practice, the preceding situation occurs when the primary propagation between the mobile and the base station are not line-of-sight. This often occurs in urban canyons, where large buildings block line-of-sight transmission from the mobile to the base station (and vice versa); thereby, placing the mobile's transmission in a "deep fade." To counteract this effect, a preferred base station includes partially adaptive array-processing to incrementally refine the initial beam pattern that is obtained using only geo-location information. Candidate approaches for partially-adaptive array processing can be readily found in the literature for fully-adaptive array processing (e.g., "Novel Adaptive Array Algorithms and Their Impact on Cellular System Capacity," by Paul Petrus incorporated herein by reference.).

The approaches to computing a mobile's true location have been investigated in detail for CDMA signal communication (see "Performance of Hyperbolic Position Location Techniques for Code-Division Multiple Access," by George A. Mizusawa, incorporated herein by reference). Implementing a GPS receiver in the phone is one candidate for providing accurate geo-location information to the base station. Alternatively, at least three base stations can be employed to triangulate the mobile location using a variety of algorithms.

FIG. 18 is a schematic block diagram of a beamshaping circuit based on an adaptive-array processing algorithms. As illustrated, the circuitry 1080 is essentially identical to that illustrated in FIG. 17. The postprocessing circuit, however, communicates with an adaptive-array module 1039 instead of with geo-location data from a mobile unit. An adaptive-array processing algorithm in the module 1039 provides the weighting signal to the on-chip programmable FIR filters 1062<sub>1-I</sub>, ..., 1062<sub>N-Q</sub>. The processing chip 1050 can be similarly employed to accommodate other cellular communication techniques.

Although preferred embodiments of the invention have been described in the context of a cellular communication system, the principles of the invention can be



- 24 -

applied to any communication system. For example, geo-location data and associated beamforming can be embodied in any radio frequency communication system such as satellite communication systems. Furthermore, the invention can be embodied in acoustic or optical communication systems.

## 5 EQUIVALENTS

While the invention has been particularly shown and described with reference to preferred embodiments thereof, it will be understood by those skilled in the art that various changes in form and details may be made therein without departing from the spirit and scope of the invention as defined by the appended claims. In particular, the various aspects of the invention can be embodied in hardware, software or firmware.

These and all other equivalents are intended to be encompassed by the following claims.

- 25 -

## CLAIMS

The invention claimed is:

1. A communication system comprising:
  - 5 a first transceiver having a first processor and a first directional antenna;
  - a second transceiver having a second processor and a second antenna;
  - a locator coupled to the second transceiver for determining the physical location of the second transceiver relative to the first transceiver;
  - 10 a communication link formed between the first and second transceivers, the link including a first wireless beam from the first antenna to the second antenna; and
  - a first beamformer in the first transceiver for shaping the first wireless beam to be directed toward the second transceiver.
2. The system of Claim 1 wherein the first and second transceivers are movable  
15 relative to one another and the beamformer periodically updates the direction of the wireless beam.
3. The system of Claim 1 wherein the wireless beam is a radio frequency beam.
4. The system of Claim 1 wherein the first transceiver is in a cellular telephone base station and the second transceiver is in a cellular telephone mobile unit.

- 26 -

5. The system of Claim 1 wherein the locator includes input from a satellite positioning system.
6. The system of Claim 1 wherein the locator includes input from a ground-based positioning system.
- 5 7. The system of Claim 1 wherein the beamformer includes a nulling circuit for rejecting signals outside of the direction of the second transceiver.
8. A cellular communication system comprising:
  - a base transceiver having a first directional antenna, the base transceiver having a fixed geographical position;
  - 10 a mobile transceiver having a second antenna, the mobile transceiver being movable relative to the base transceiver;
  - a wireless communication link between the base and mobile transceivers formed by a signal between the antennas;
  - a positioning system for detecting the geographical position of the mobile transceiver, the position of the mobile transceiver being  
15 communicated to the base transceiver over the communication link; and
  - a beamformer in the base transceiver for modifying the signal in response to the relative motion of the transceivers.
9. The system of Claim 8 wherein the beamformer periodically updates the  
20 direction of the wireless beam.
10. The system of Claim 8 wherein the signal is a radio frequency beam.

- 27 -

11. The system of Claim 8 wherein the positioning system includes input from a satellite positioning system.
12. The system of Claim 8 wherein the positioning system includes input from a ground-based positioning system.
- 5 13. The system of Claim 8 wherein the beamformer includes a plurality of programmable filter arrays.
14. The system of Claim 8 wherein the beamformer includes a table stored in memory for providing antenna weights to modify the signal.
15. The system of Claim 8 wherein the second antenna is a directional antenna.
- 10 16. A method for operating a communication system comprising:
  - providing a first transceiver having a first processor and a first directional antenna;
  - providing a second transceiver having a second processor and a second antenna;
  - 15 forming a communication link between the first and second transceivers, the link including a first wireless beam from the first antenna to the second antenna; and
  - in a first beamformer in the first transceiver, responding to the physical location of the second transceiver and shaping the first wireless beam to be directed toward the second transceiver.
- 20

- 28 -

17. The method of Claim 16 wherein the first and second transceivers are movable relative to one another and the beamformer periodically updates the direction of the signal.
18. The method of Claim 16 wherein the wireless beam is a radio frequency beam.  
5
19. The method of Claim 16 wherein the first transceiver is in a cellular telephone base station and the second transceiver is in a cellular telephone mobile unit.
20. The method of Claim 16 wherein the locator includes input from a satellite positioning system.  
10
21. The method of Claim 16 wherein the locator includes input from a ground-based positioning system.
22. The method of Claim 16 wherein the beamformer includes a nulling circuit to reject signals outside of the direction of the second transceiver.
- 15 23. A method of operating a cellular communication system comprising:  
    providing a base transceiver having a first directional antenna, the base transceiver having a fixed geographical position;  
    providing a mobile transceiver having a second antenna, the mobile transceiver being movable relative to the base transceiver;  
20      a wireless communication link between the base and mobile transceivers forming by a signal between the antennas;

- 29 -

in a positioning system, detecting the geographical position of the mobile transceiver, the position of the mobile transceiver being communicated to the base transceiver over the communication link; and  
in a beamformer in the base transceiver, modifying the signal in response to the relative motion of the transceivers.

- 5
24. The method of Claim 23 wherein the step of modifying the signal comprises periodically updating the direction of the signal.
25. The method of Claim 23 wherein the signal is a radio frequency beam.
26. The method of Claim 23 wherein the step of detecting comprises receiving  
10 input from a satellite positioning system.
27. The method of Claim 23 wherein the step of detecting comprises receiving input from a ground-based positioning system.
28. The method of Claim 23 wherein the beamformer includes a plurality of programmable filter arrays.
- 15 29. The method of Claim 23 wherein the step of modifying the signal comprises providing antenna weights from a table stored in memory.
30. The method of Claim 23 wherein the second antenna is a directional antenna.

- 30 -

31. A cellular communication system comprising:
- a base transceiver having a first directional antenna, the base transceiver having a fixed geographical position;
  - a mobile transceiver having a second directional antenna, the mobile transceiver being movable relative to the base transceiver;
  - a wireless communication link between the base and mobile transceivers formed by a signal between the antennas;
  - a positioning system for detecting the geographical position of the mobile transceiver, the position of the mobile transceiver being communicated to the base transceiver over the communication link; and
  - a first beamformer in the base transceiver and a second beamformer in the mobile transceiver for modifying the signal in response to the relative motion of the transceivers.
32. The system of Claim 31 wherein the beamformers periodically update the direction of the wireless beam.
33. The system of Claim 31 wherein the beamformers modify the signal to be omnidirectional when the base transceiver and the mobile transceiver are separated by less than a specific range.
34. The system of Claim 31 wherein the signal is a radio frequency beam.
35. The system of Claim 31 wherein the positioning system includes input from a satellite positioning system.
36. The system of Claim 31 wherein the positioning system includes input from a ground-based positioning system.

- 31 -

37. The system of Claim 31 wherein the beamformers include a plurality of programmable filter arrays.
38. The system of Claim 31 wherein the beamformers include a table stored in memory for providing antenna weights to modify the signal.
- 5 39. A method of operating a cellular communication system comprising:  
providing a base transceiver having a first directional antenna, the  
base transceiver having a fixed geographical position;  
providing a mobile transceiver having a second directional antenna,  
the mobile transceiver being movable relative to the base transceiver;  
10 a wireless communication link between the base and mobile  
transceivers forming by a signal between the antennas;  
in a positioning system, detecting the geographical position of the  
mobile transceiver, the position of the mobile transceiver being  
communicated to the base transceiver over the communication link; and  
15 in a first beamformer in the base transceiver and a second  
beamformer in the mobile transceiver, modifying the signal in response to the  
relative motion of the transceivers.
40. The method of Claim 39 wherein the step of modifying the signal comprises periodically updating the direction of the signal.
- 20 41. The method of Claim 40 wherein the step of modifying comprises determining the range between the base transceiver and the mobile transceiver and, when the range is less than a specific range, modifying the signal to be omnidirectional.



42. The method of Claim 39 wherein the signal is a radio frequency beam.
43. The method of Claim 39 wherein the step of detecting comprises receiving input from a satellite positioning system.
44. The method of Claim 39 wherein the step of detecting comprises receiving  
5 input from a ground-based positioning system.
45. The method of Claim 39 wherein the beamformers include a plurality of programmable filter arrays.
46. The method of Claim 39 wherein the step of modifying the signal comprises providing antenna weights from a table stored in memory.
- 10 47. A direction finder in a transceiver, comprising:  
a sensor for detecting the geographical location of a first transceiver;  
a memory having stored therein the geographical location of a second  
transceiver; and  
a deterministic directional unit for calculating the direction of the  
15 second transceiver relative to the first transceiver.
48. The direction finder of Claim 47 wherein the sensor includes a global positioning system receiver.
49. The direction finder of Claim 47 wherein the first transceiver is moveable between a plurality of geographical locations.

- 33 -

50. The direction finder of Claim 49 wherein the second transceiver is moveable between a plurality of geographical locations.
51. The direction finder of Claim 47 further comprising a directional antenna responsive to the deterministic directional unit for receiving a wireless signal  
5 from the second transceiver.
52. A method operating a direction finder in a transceiver, comprising the steps of:  
using a sensor to detect the geographical location of a first transceiver;  
10 storing in memory the geographical location of a second transceiver;  
and  
deterministically calculating the direction of the second transceiver relative to the first transceiver.
53. The method of Claim 52 wherein the step of using a sensor comprises  
15 receiving geo-location data from a global positioning system.
54. The method of Claim 52 further comprises the step of moving the first transceiver between a plurality of geographical locations.
55. The method of Claim 54 further comprising the step of moving the second transceiver between a plurality of geographical locations.
- 20 56. The method of Claim 52 further comprising the step of operating a directional antenna in response to the calculated direction for receiving a wireless signal from the second transceiver.

57. A beamforming circuit for a communication system comprising a plurality of sampling circuits for receiving communication signals;  
a plurality of programmable finite impulse response (FIR) filters, each FIR filter being connected to a sampling circuit; and  
5 a summing circuit that sums filtered signals from the plurality of FIR filters.
58. The circuit of Claim 57 wherein the sampling circuits, the plurality of programmable FIR filters and the summing circuit are formed on a single integrated circuit.
- 10 59. The circuit of Claim 57 further comprising a multiplier connected to each sampling circuit to generate an in-phase channel and a quadrature channel, each channel being connected to a filter, a converter and one of the FIR filters.
- 15 60. The circuit of Claim 57 wherein the communication system comprises a cellular network including a plurality of transceivers that communicate by wireless link with mobile transceiver units, and further including a base station having an adaptive array processor providing weighting signals to the FIR filters.

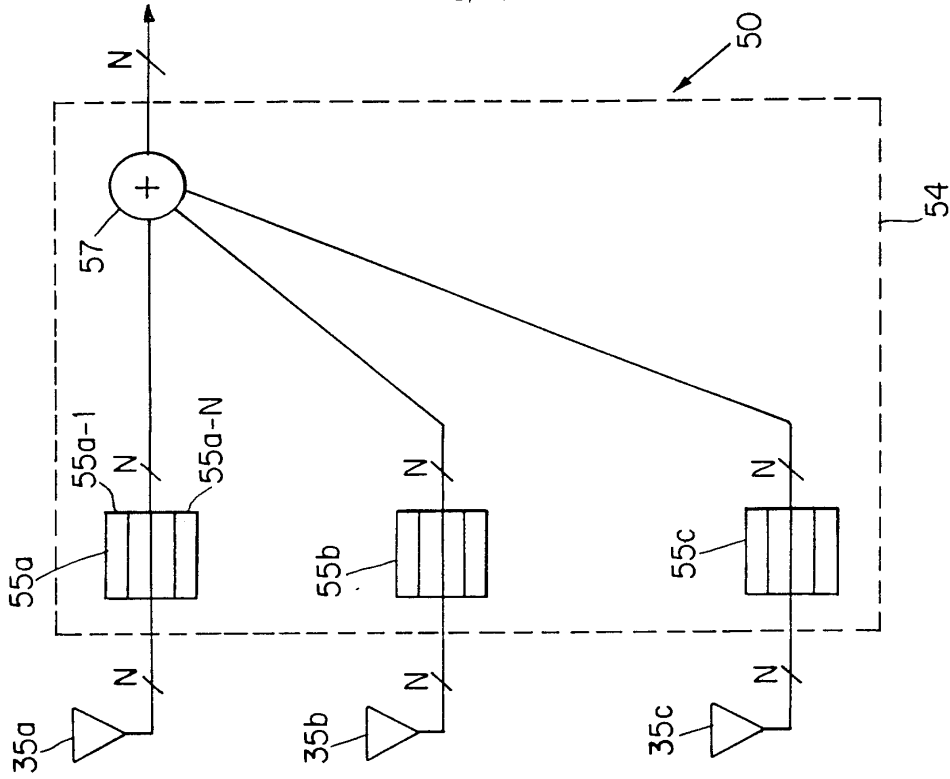


FIG. 3

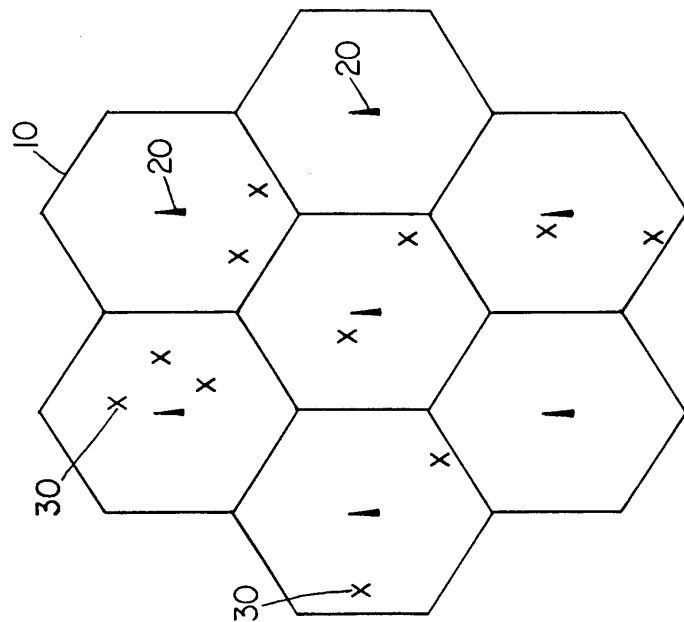


FIG. 1

SUBSTITUTE SHEET (RULE 26)

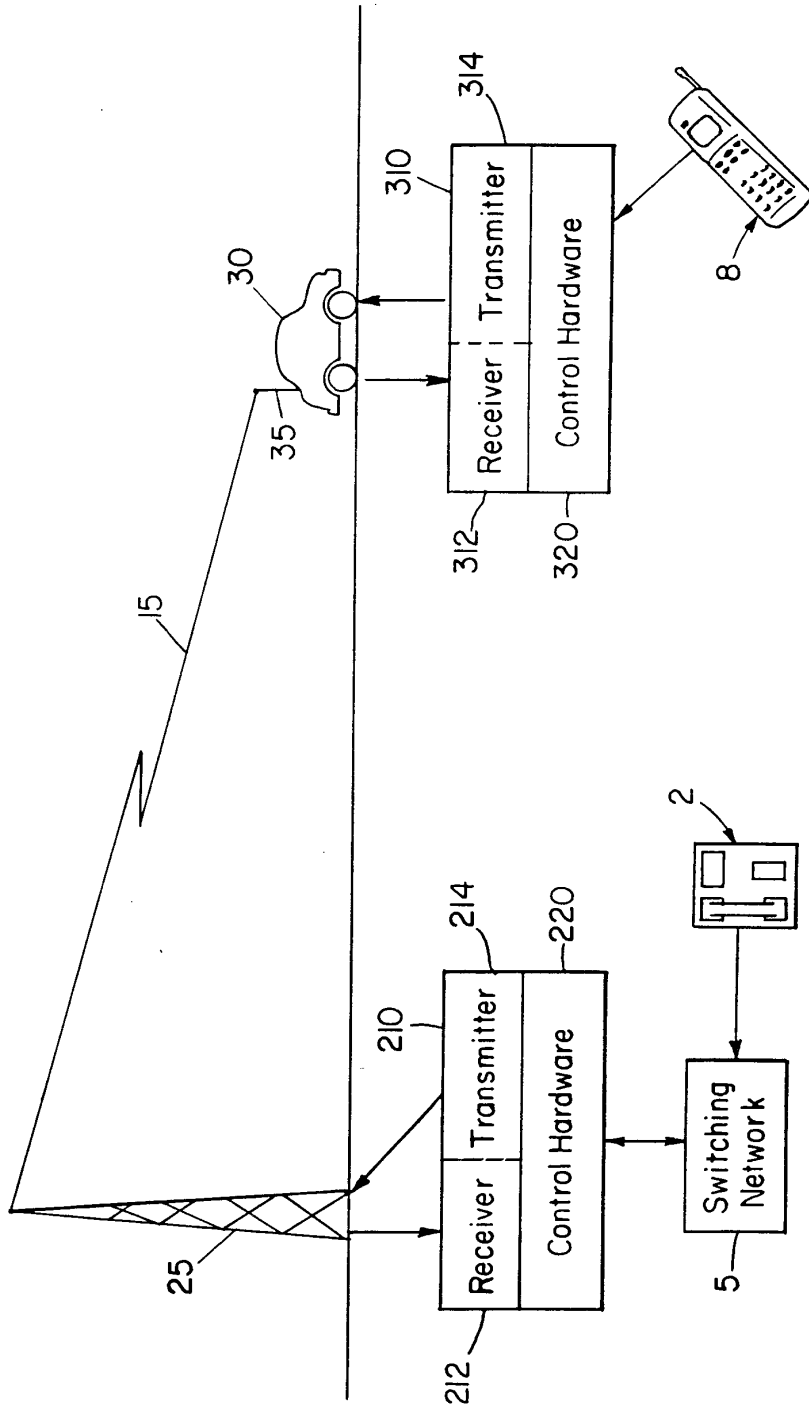


FIG. 2

SUBSTITUTE SHEET (RULE 26)

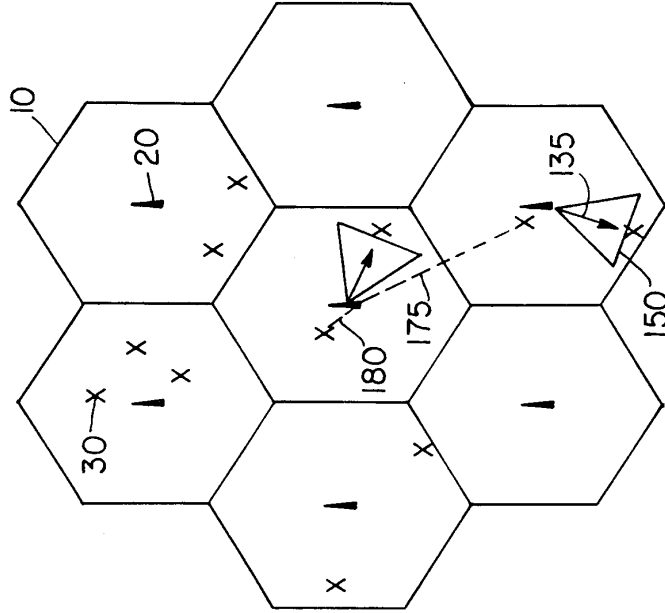


FIG. 5

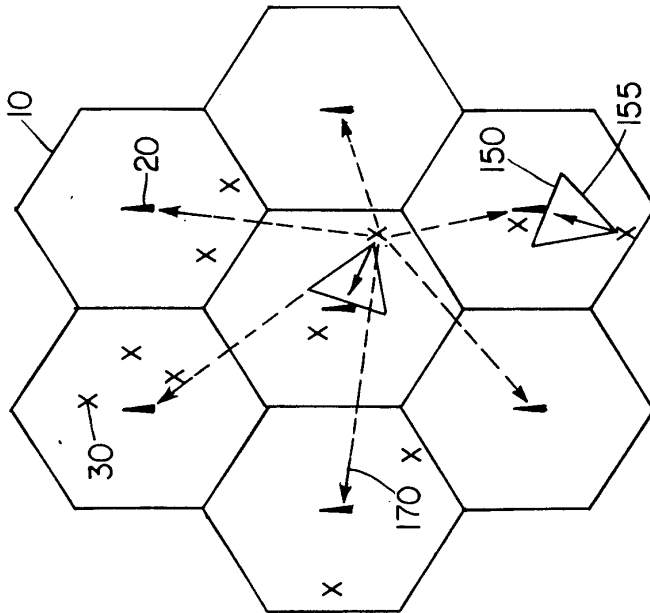


FIG. 4

SUBSTITUTE SHEET (RULE 26)

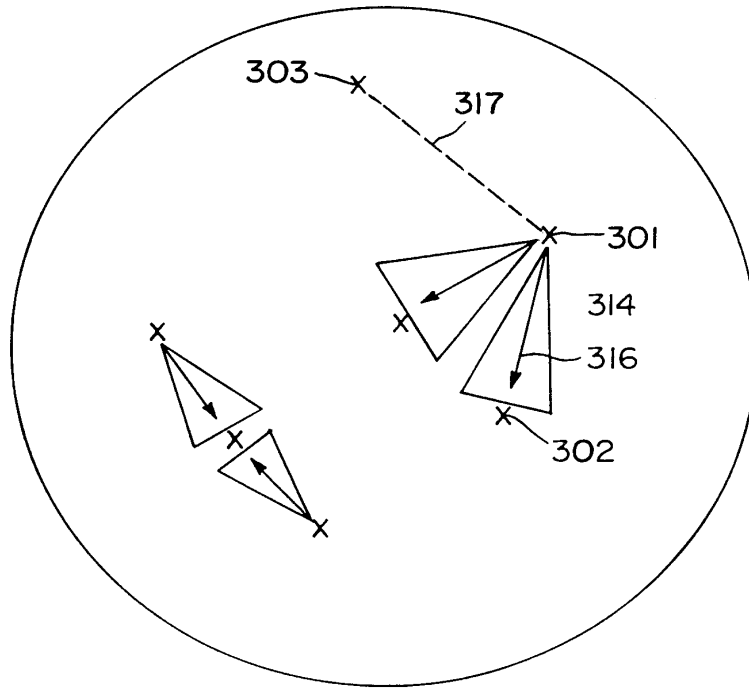


FIG. 6

SUBSTITUTE SHEET (RULE 26)

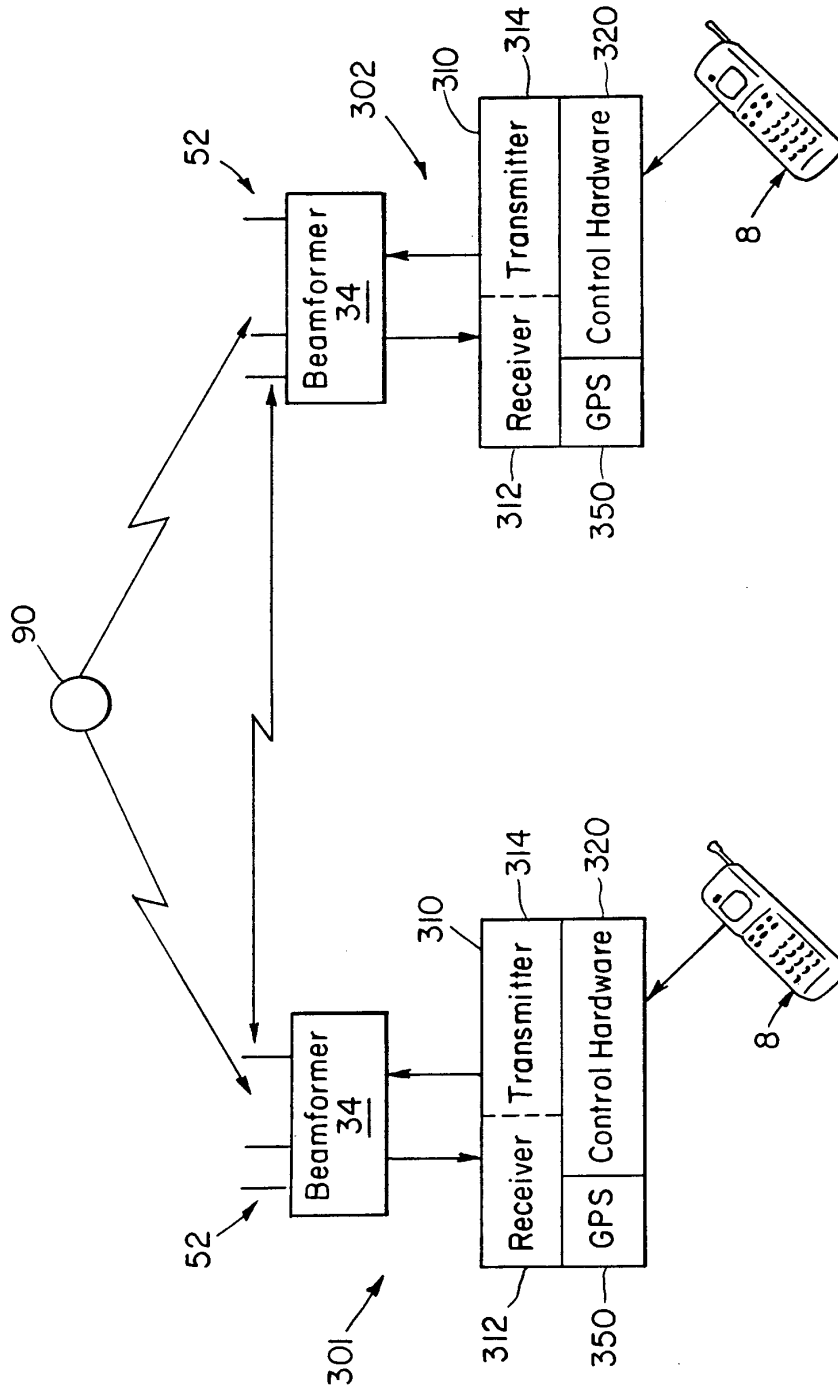


FIG. 7

SUBSTITUTE SHEET (RULE 26)



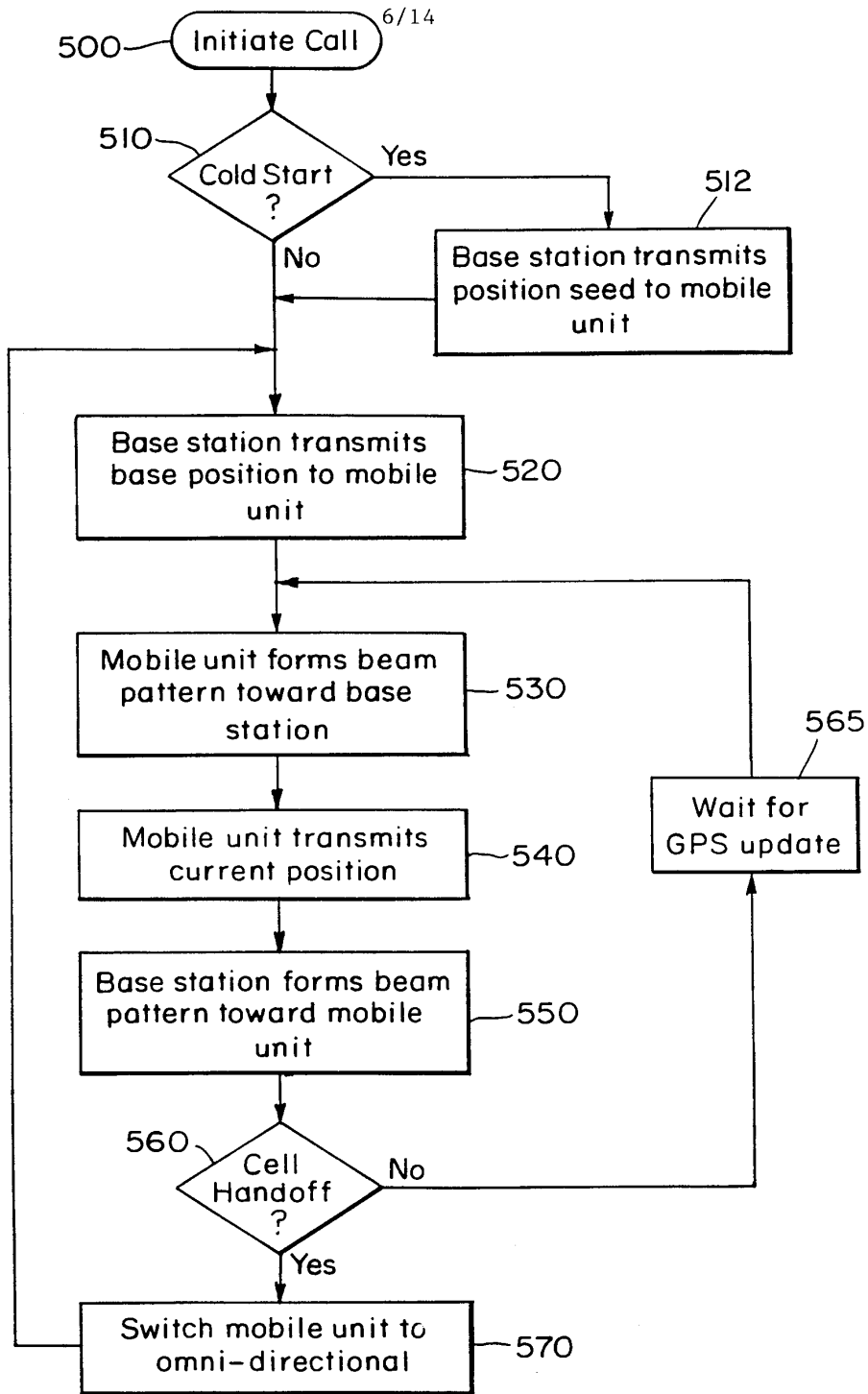


FIG. 8

SUBSTITUTE SHEET (RULE 26)

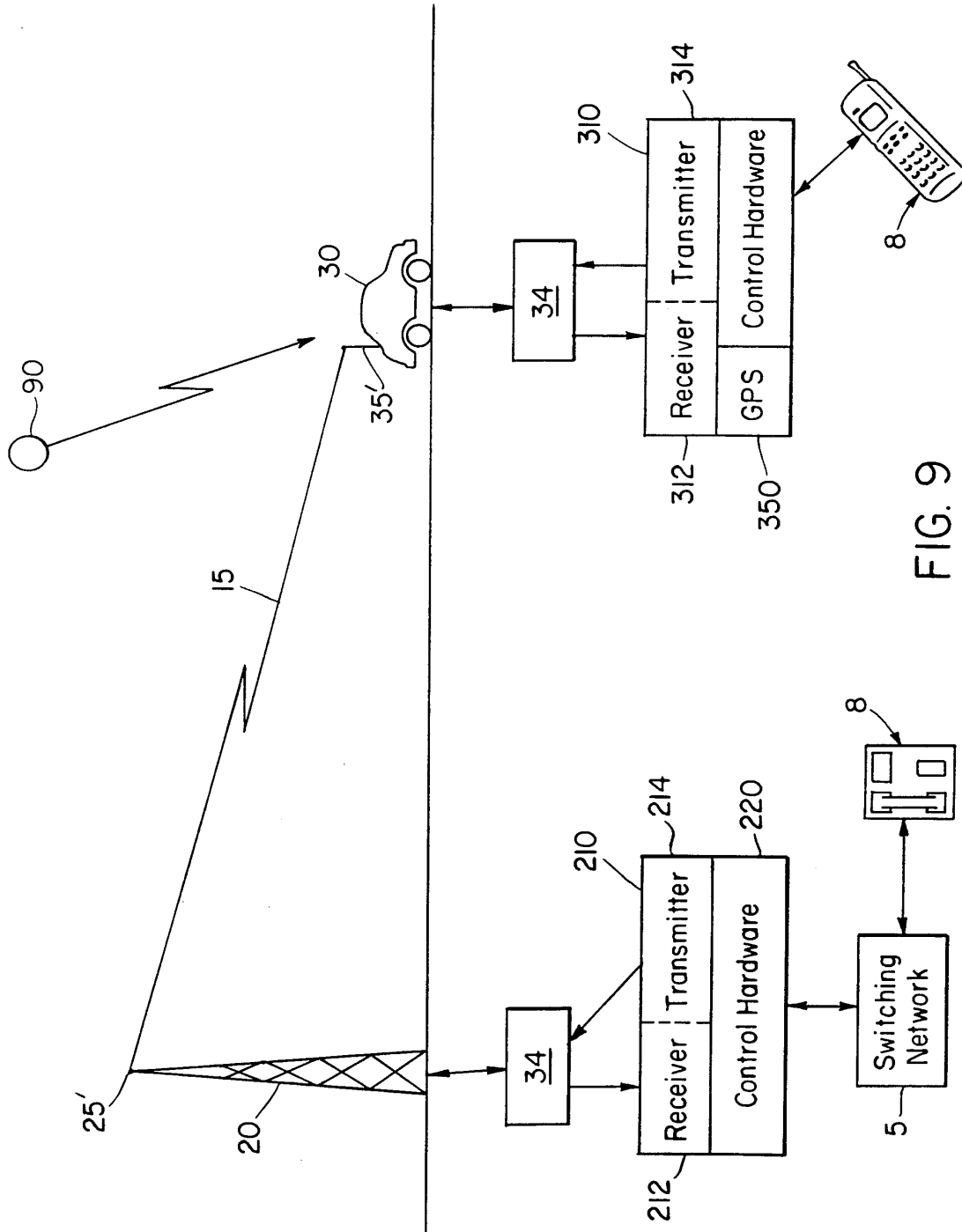


FIG. 9

SUBSTITUTE SHEET (RULE 26)

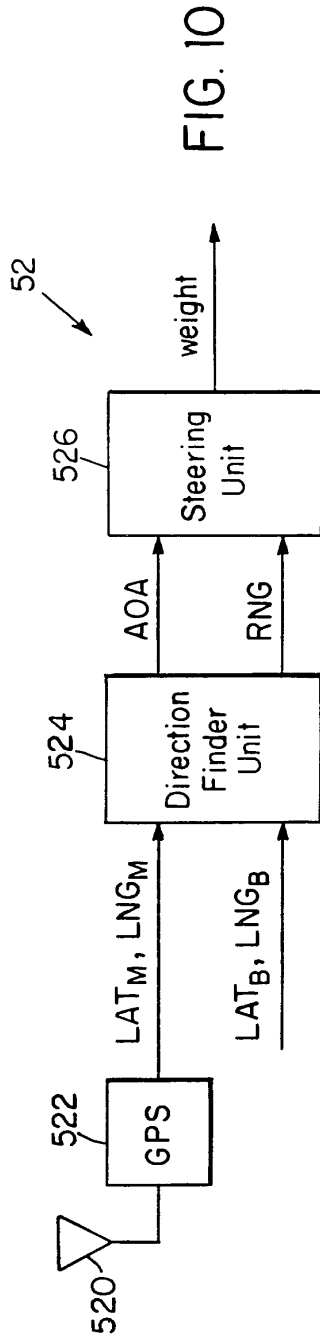


FIG. 10

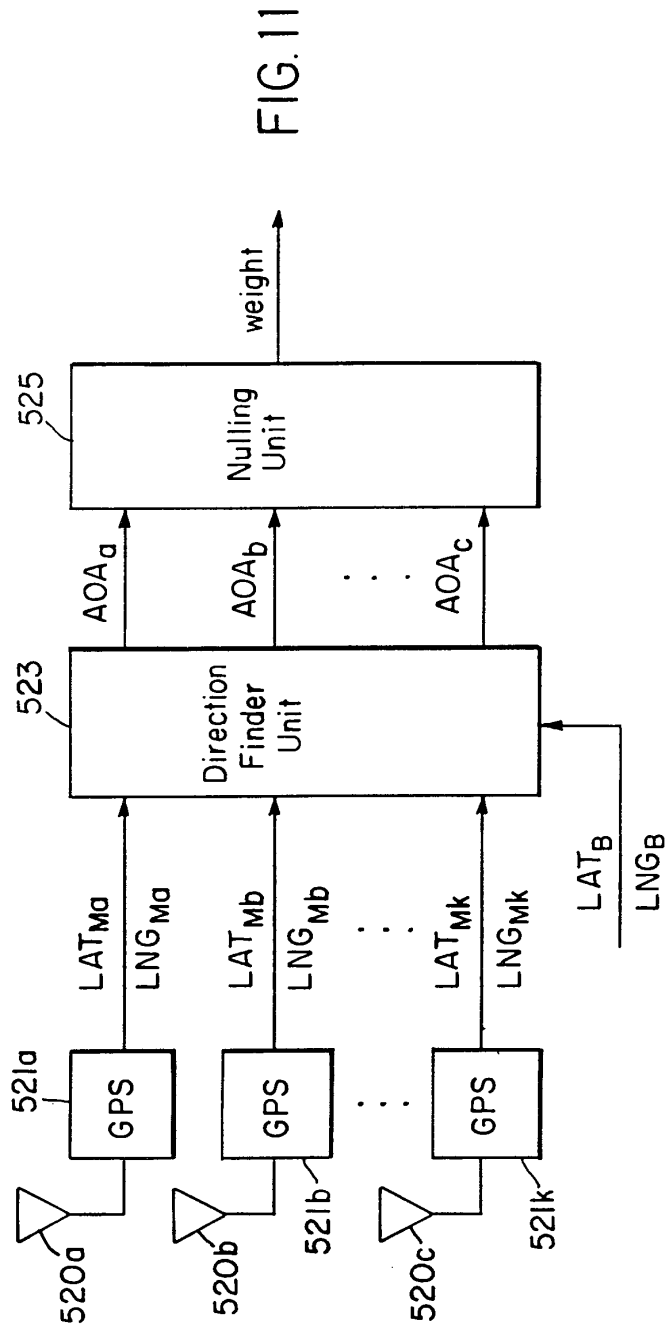


FIG. 11

SUBSTITUTE SHEET (RULE 26)

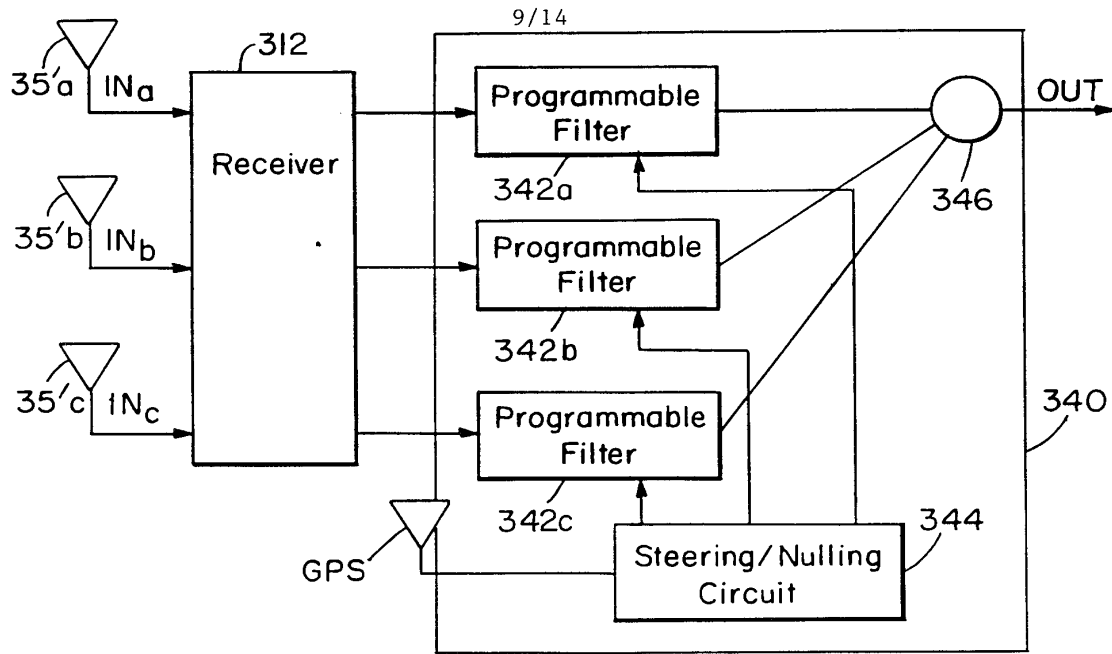


FIG. 12

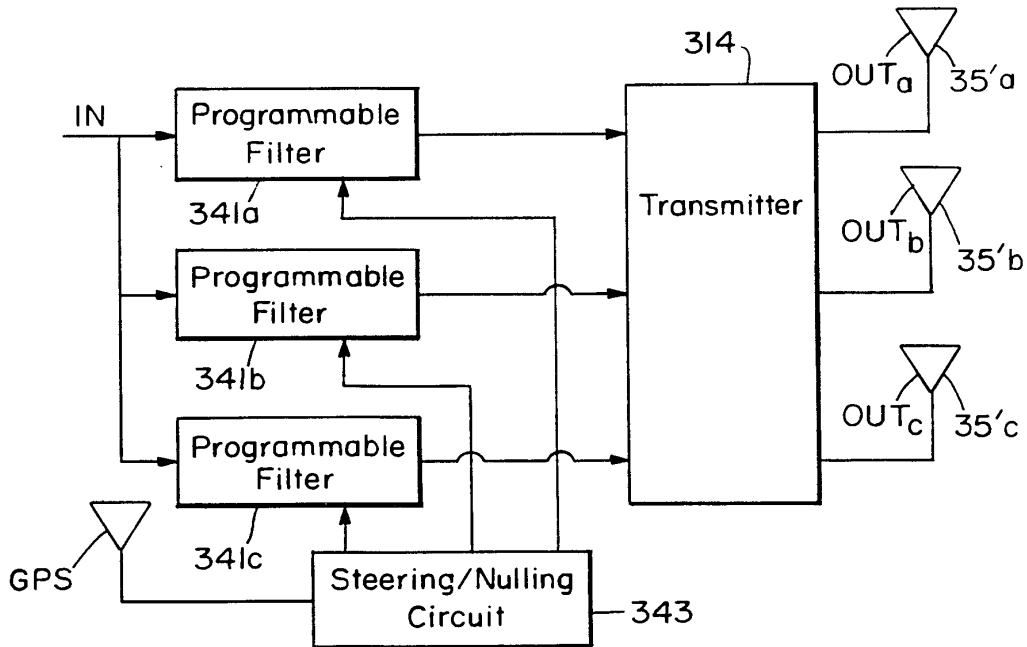


FIG. 13

SUBSTITUTE SHEET (RULE 26)

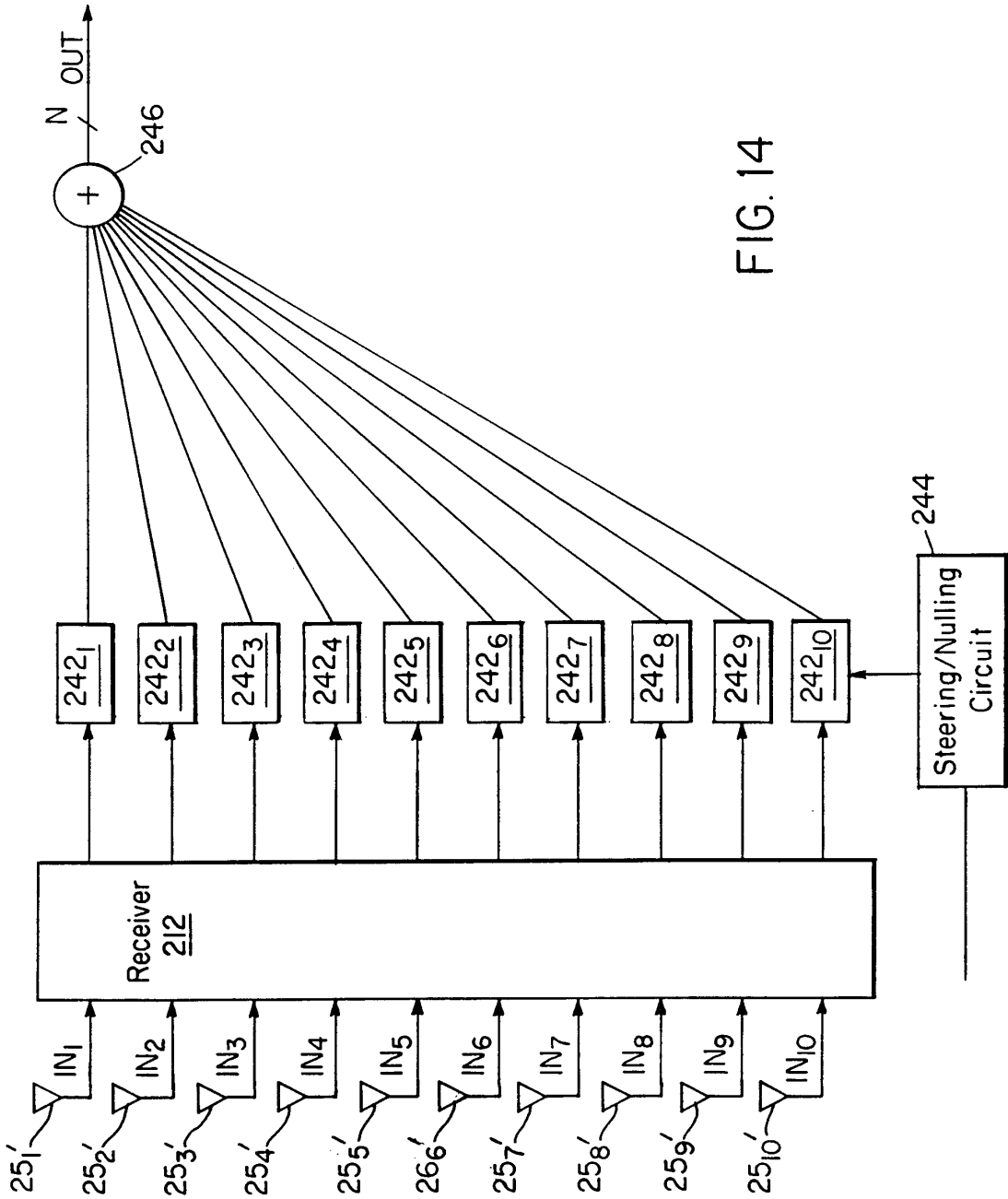


FIG. 14

SUBSTITUTE SHEET (RULE 26)

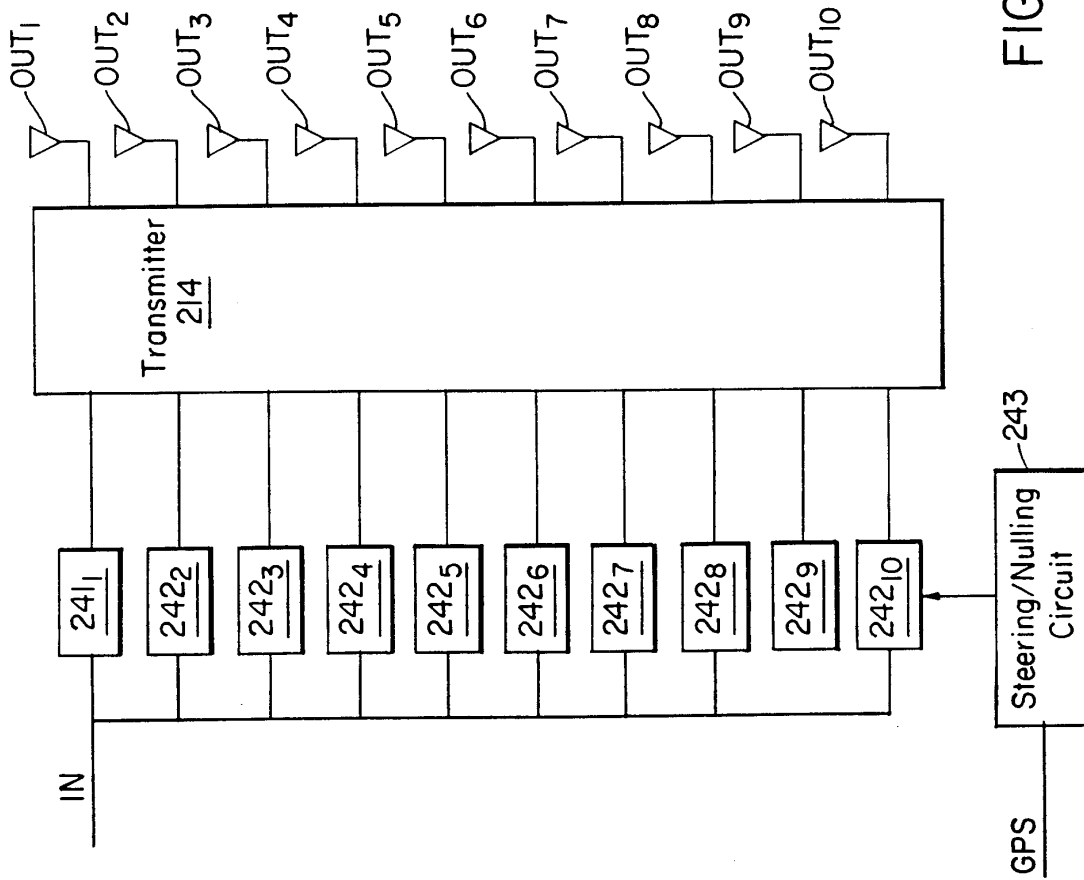


FIG. 15

SUBSTITUTE SHEET (RULE 26)

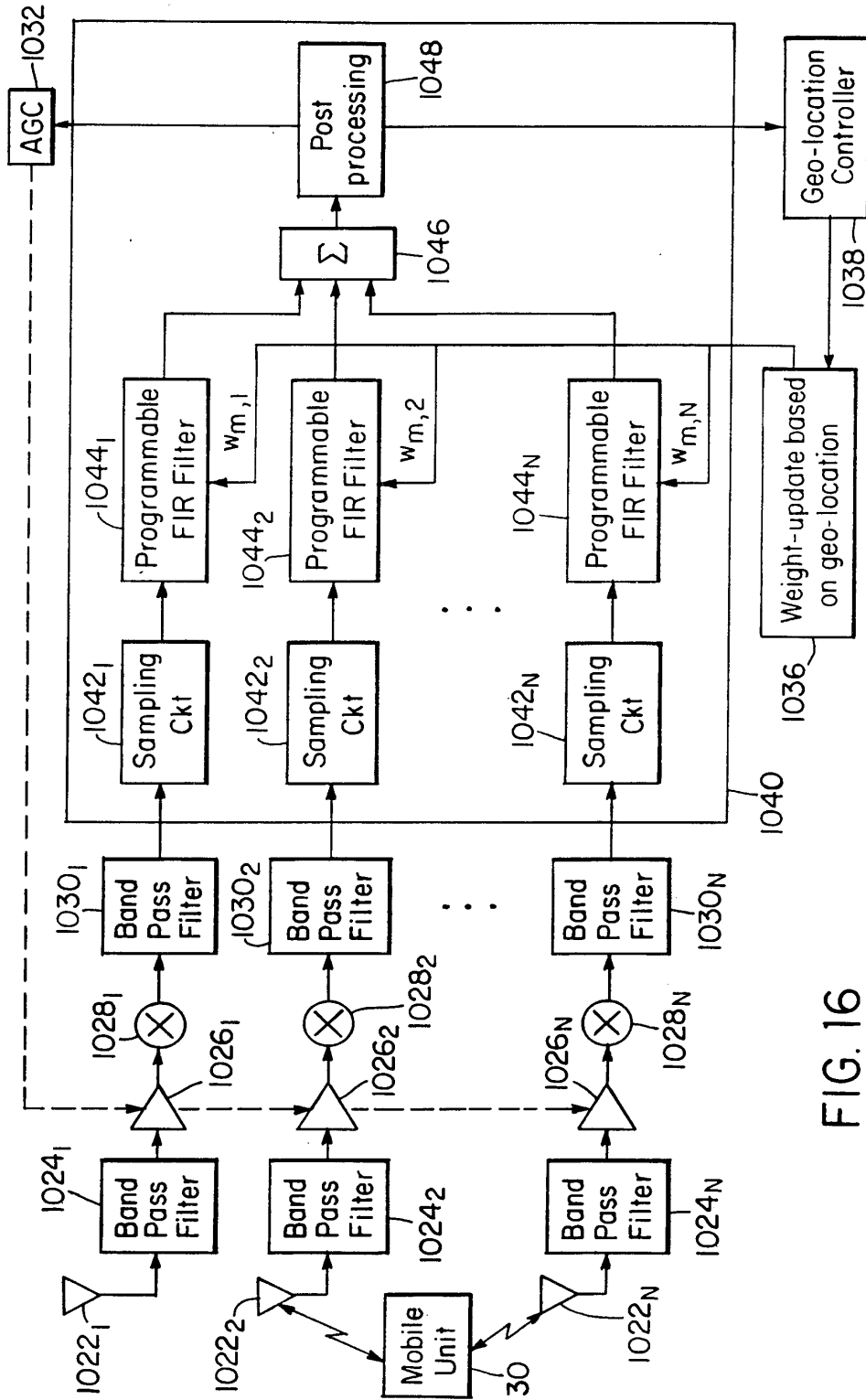


FIG. 16

SUBSTITUTE SHEET (RULE 26)

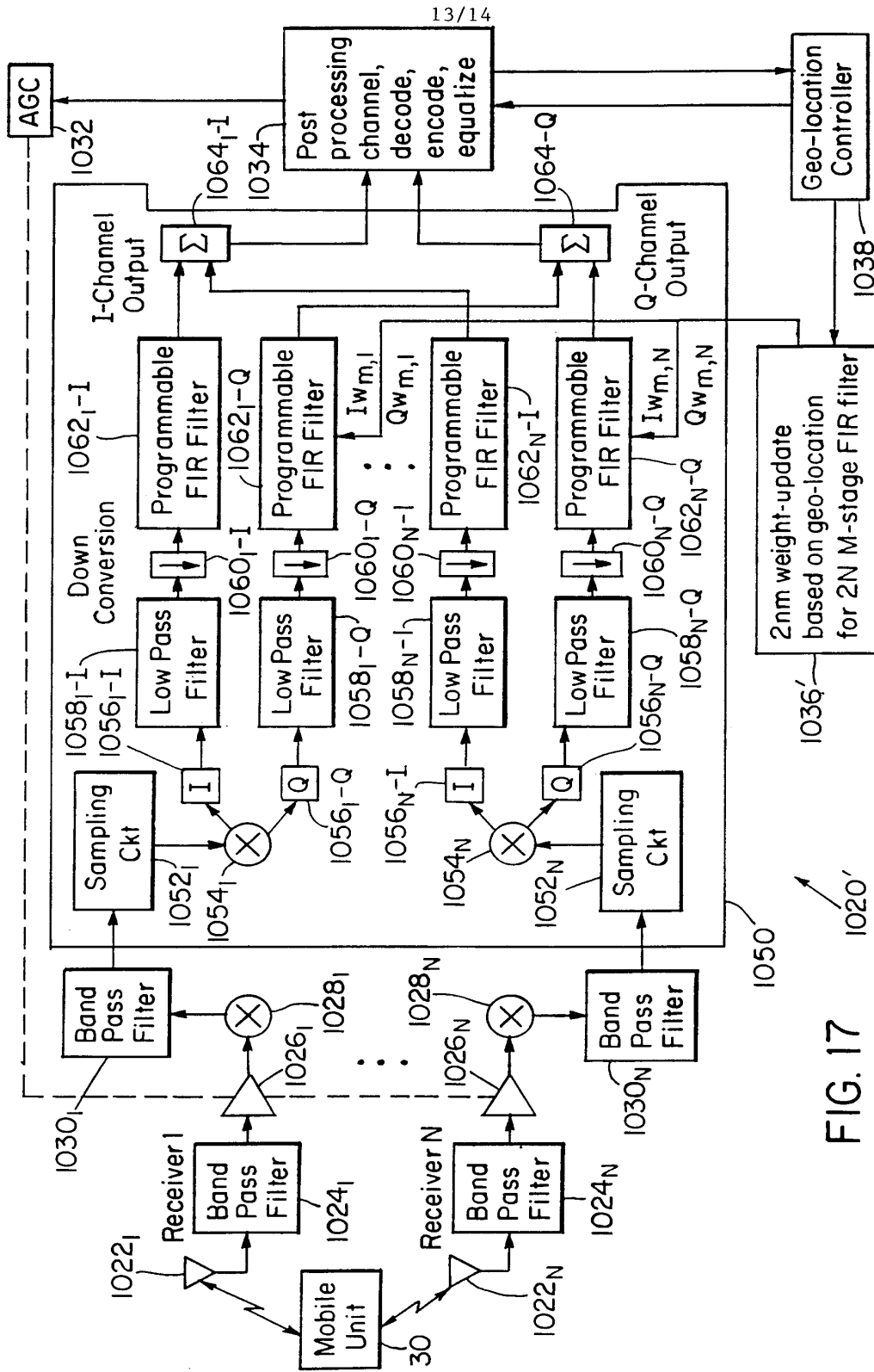


FIG. 17

SUBSTITUTE SHEET (RULE 26)



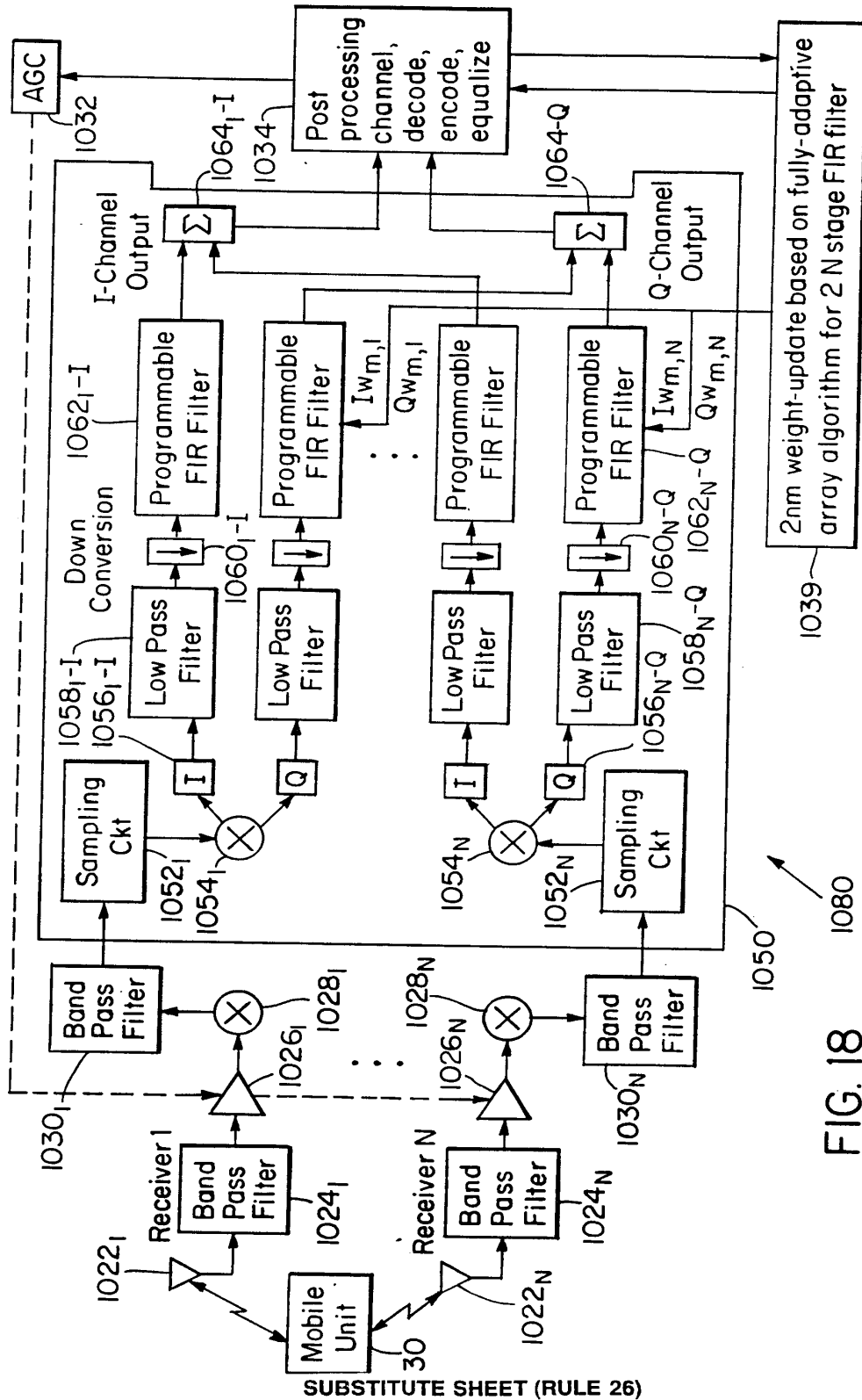


FIG. 18



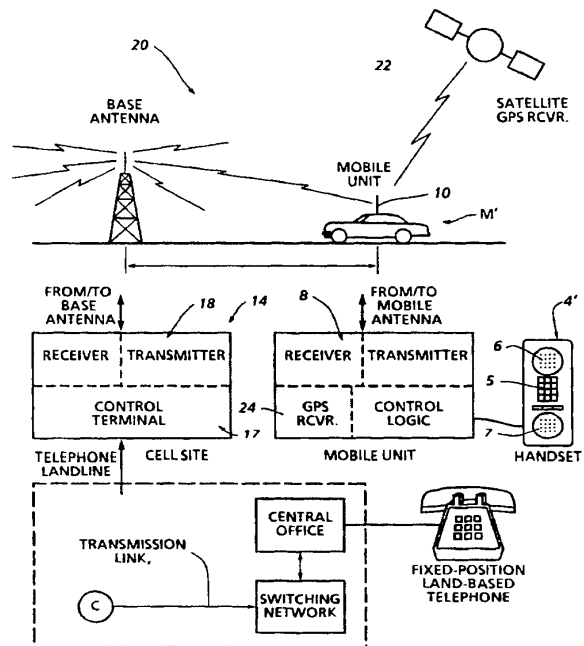
INTERNATIONAL APPLICATION PUBLISHED UNDER THE PATENT COOPERATION TREATY (PCT)

|   |                  |   |
|---|------------------|---|
| <p>(51) International Patent Classification<sup>5</sup> :<br/><b>H04M 11/06</b></p>   | <p><b>A1</b></p> | <p>(11) International Publication Number: <b>WO 94/27398</b><br/><br/>(43) International Publication Date: 24 November 1994 (24.11.94)</p>  |
| <p>(21) International Application Number: PCT/US94/04500<br/>(22) International Filing Date: 29 April 1994 (29.04.94)<br/><br/>(30) Priority Data:<br/>08/057,833      7 May 1993 (07.05.93)      US<br/><br/>(71)(72) Applicants and Inventors: DENNISON, Everett [US/US];<br/>200 Glenview, Canfield, OH 44406 (US). PHARIS, Albert,<br/>H. [US/US]; 7130 S. Racoon Road, Canfield, OH 44406<br/>(US).<br/><br/>(74) Agent: GERNSTEIN, Terry, M.; 1015 Salt Meadow Lane,<br/>McLean, VA 22101 (US).</p> |                  | <p>(81) Designated States: AT, AU, BR, CA, CH, CN, DE, DK, ES, FI, GB, HU, JP, KR, LU, NL, NO, NZ, PL, PT, RO, RU, SE, UA, European patent (AT, BE, CH, DE, DK, ES, FR, GB, GR, IE, IT, LU, MC, NL, PT, SE).<br/><br/><b>Published</b><br/><i>With international search report.</i></p> |

(54) Title: CELLULAR TELEPHONE SYSTEM THAT USES POSITION OF A MOBILE UNIT TO MAKE CALL MANAGEMENT DECISIONS

(57) Abstract

A cellular telephone system (20) includes a plurality of cell sites (14) and a mobile telephone switching office (MTSO, 12). Call management, including selection of a cell site most appropriate for a call associated with a mobile unit (M, M') are made based on the geographic location of the mobile unit as opposed to the strength of the signal associated with the call. The geographic location of the mobile unit is precisely determined using triangulation, a NAVSTAR global positioning system, or its equivalent. Each mobile unit includes a GPS receiver (24) that receives information from a geostationary satellite (22) to determine the precise location of the mobile unit. This position information is relayed to the cell site initially managing the mobile unit, and the mobile unit is handed off to a cell site that is most appropriate for the call. Initial selection of an entrance cell site is made based on signal strength, but further call management decisions are made based on location of the mobile unit.



**FOR THE PURPOSES OF INFORMATION ONLY**

Codes used to identify States party to the PCT on the front pages of pamphlets publishing international applications under the PCT.

|    |                          |    |                                       |    |                          |
|----|--------------------------|----|---------------------------------------|----|--------------------------|
| AT | Austria                  | GB | United Kingdom                        | MR | Mauritania               |
| AU | Australia                | GE | Georgia                               | MW | Malawi                   |
| BB | Barbados                 | GN | Guinea                                | NE | Niger                    |
| BE | Belgium                  | GR | Greece                                | NL | Netherlands              |
| BF | Burkina Faso             | HU | Hungary                               | NO | Norway                   |
| BG | Bulgaria                 | IE | Ireland                               | NZ | New Zealand              |
| BJ | Benin                    | IT | Italy                                 | PL | Poland                   |
| BR | Brazil                   | JP | Japan                                 | PT | Portugal                 |
| BY | Belarus                  | KE | Kenya                                 | RO | Romania                  |
| CA | Canada                   | KG | Kyrgyzstan                            | RU | Russian Federation       |
| CF | Central African Republic | KP | Democratic People's Republic of Korea | SD | Sudan                    |
| CG | Congo                    | KR | Republic of Korea                     | SE | Sweden                   |
| CH | Switzerland              | KZ | Kazakhstan                            | SI | Slovenia                 |
| CI | Côte d'Ivoire            | LI | Liechtenstein                         | SK | Slovakia                 |
| CM | Cameroon                 | LK | Sri Lanka                             | SN | Senegal                  |
| CN | China                    | LU | Luxembourg                            | TD | Chad                     |
| CS | Czechoslovakia           | LV | Latvia                                | TG | Togo                     |
| CZ | Czech Republic           | MC | Monaco                                | TJ | Tajikistan               |
| DE | Germany                  | MD | Republic of Moldova                   | TT | Trinidad and Tobago      |
| DK | Denmark                  | MG | Madagascar                            | UA | Ukraine                  |
| ES | Spain                    | ML | Mali                                  | US | United States of America |
| FI | Finland                  | MN | Mongolia                              | UZ | Uzbekistan               |
| FR | France                   |    |                                       | VN | Viet Nam                 |
| GA | Gabon                    |    |                                       |    |                          |

CELLULAR TELEPHONE SYSTEM THAT  
USES POSITION OF A MOBILE UNIT  
TO MAKE CALL MANAGEMENT DECISIONS

Technical Field

The present invention relates to the general art of cellular mobile radiotelephone (CMR) technology, and to the particular field of managing the calls in a cellular system.

The present application is a continuation-in-part of Serial Number 07/813,494 filed on 12/26/91, and incorporates the entire disclosure thereof by reference.

Background Art

CMR is a rapidly growing telecommunications system. The typical CMR system includes a multiplicity of cells, such as indicated in Figure 1. A particular geographic area is subdivided into a multiplicity of subareas, with each of the subareas being serviced by a stationary transmitter/receiver setup. The cells are set up to carry signals to and from mobile units M in the range of the cell. If one cell becomes too crowded, it can be divided into smaller cells, by a process known as cell splitting. As can be seen from Figure 1, any particular geographic area can become quite complicated with cells overlapping each other, and overlapping cells of other neighboring cellular systems. It is noted that the term "cellular" is intended to be a term of convenience, and is not intended to be limiting. The present disclosure is intended to encompass any communication system in which an overall area can be divided into one or more subareas such as shown in Figure 1.

A typical CMR set up is indicated in Figures 2 through 7, and will be described so an understanding of the problem to which this invention is directed can be obtained.

Figures 2, 3, 4 and 4A show a typical cellular telephone unit 2 having a unique mobile identification number stored in a suitable location such as an electrically erasable programmable read-only memory (not shown). Telephone units of this kind are known to those skilled in this art, and thus will not be described in detail.

The telephone unit 2 includes a handset 4 having a keypad 5 as well as a speaker 6 and a microphone 7. A transceiver 8, ordinarily built into the telephone unit 2, exchanges signals

**SUBSTITUTE SHEET (RULE 26)**

via an antenna 10 with a mobile telecommunications switching office or MTSO 12 via a cell site 14. A duplexer 15 connects the antenna to the transceiver. The cell site 14 includes an antenna 16 connected to a control terminal 17 via a transceiver 18. The cell 14 is connected to the MTSO via a transmission link 20.

Referring to Figures 4 and 5, the operation of the CMR can be understood. The mobile units communicate with the MTSO via cell sites. Under systems known prior to the parent application, the systems in the MTSO determine which cell site will handle the mobile unit based on the signal strength received by one or more cell sites in the system. The MTSO performs the decision making in providing service to the mobile units, controls the handoff process, contains subscriber information and performs telephone office switching functions. The mobile unit M moves about the geographic areas covered by the various cells as indicated in Figure 1. As that mobile unit moves about, it decodes the overhead message control signals generated by various cell site control channels. The mobile unit locks onto the cell site that is emitting the strongest signal. The mobile unit rescans channels periodically to update its status. If, for example, a fixed-position land-based telephone T is used to call the mobile unit, a signal is sent via landlines L, to the central office CO of a public/switched telephone system (PTSN) 12A. This system then utilizes the switching network SN associated therewith to call the MTSO 12 via a transmission link L1. The MTSO then utilizes its own switching network and generates a page request signal to all cell sites via transmission links, such as the transmission link 20. The cell site which has been notified of the presence of the mobile unit M sends a signal back to the MTSO via the landlines alerting the MTSO of the presence of the mobile unit. The MTSO then orders the mobile unit, via the notifying cell site, to tune to an assigned channel and receive the call. Billing and other business information are recorded in the MTSO at this time.

On the other hand, during call origination, the mobile unit rescans the control channels to determine which is the best server based on signal strength. Upon selecting the best

**SUBSTITUTE SHEET (RULE 26)**

server, the mobile unit transmits call site information on the control channel receive frequency and then receives a voice channel to tune to if the mobile unit is authorized to place a call.

5           As the mobile unit moves, the signal strength between that mobile unit and the originating cell site changes, and perhaps diminishes. Since signal strength is an inverse function of the square of the distance between the mobile unit and the cell site, signal strength can change rapidly and drastically as the  
10           mobile unit moves with respect to the cell site and therefore must be monitored closely. Moreover, signal strength can be strongly affected by terrain, environmental conditions as well as interference from other sources. The MTSO has a signal strength table ST, and signal strength from the mobile unit is  
15           constantly compared to acceptable signal strength levels in the table. Such a table can be located in each cell site if desired.

          Should signal strength diminish below a preset range, the MTSO generates a "locate request" signal to all cell sites that  
20           neighbor the original cell site. Each of such neighboring cell sites receiving a signal from the mobile unit signals the MTSO, and the signal strength from such neighboring cell sites are checked against the signal strength table. The MTSO makes a decision as to which cell site should control the call, and  
25           notifies the original cell site to order the mobile unit to retune to a voice channel of the new cell site.

          As soon as the mobile unit retunes, the mobile unit completes the call via the new cell site channel. This transfer of control is known as a handoff.

30           While this method of making switching decisions has worked well in the past, the growth and sophistication of the cellular industry has resulted in severe drawbacks to this method. First, due to uneven terrain, unpredictable environmental conditions, interference and the like, many cellular companies  
35           have been required to construct numerous cell sites. These cells often overlap neighboring cell sites and provide redundant coverage. This is extremely expensive, not only from the standpoint of construction costs, but due to monitoring and staffing costs as well. Even at this, conditions can change so

**SUBSTITUTE SHEET (RULE 26)**

rapidly that coverage may still be inconsistent.

Still further, due to idiosyncrasies in terrain and environment, a mobile unit may use a cell that is located far from the mobile unit rather than a cell located immediately adjacent to that mobile unit. Hilly terrain is a common example of this problem. While this may not be a technical problem, it is important because a cellular company cannot assess long distance charges and/or message units to the calls. This deprives the cellular company of income that it could otherwise receive and customers of optimum service. Communities are also deprived of tax income that might be assessed against such calls as well.

Still further, since only signal strength is used to make switching decisions, the location of a caller is not ascertainable. This could be important in keeping track of calls.

Other problems that have been experienced in such cellular systems include the inability to completely control the cell site transmit signal, crosstalk noise interference, dropped calls, overlap and an inability to adequately service areas with undulating terrain without infringing the borders of other cellular territories.

Therefore, there is a need for a cellular system that can provide consistently high quality service, yet can do so with a minimum number of cell sites in a particular geographic area. Still further, there is a need for a cellular system that can accurately assess charges for all CMR services including message units for calls covering a certain distance within the geographic area.

Exacxt location through the use of Geopositional Satellite information (as explained in the parent application) is one improvement.

#### Objects of the Invention

It is a main object of the present invention to provide a cellular system that can provide high quality service using only a minimum number of cell sites within a given geographic area.

It is another object of the present invention to improve the performance of the incorporated patent application.

**SUBSTITUTE SHEET (RULE 26)**

It is another object of the present invention to provide a cellular system that uses the exact geographic location of a mobile unit in making call management decisions.

5 It is another object of the present invention to provide a cellular system that uses the exact geographic location of a mobile unit in making call management decisions, with that exact geographic location being determined using triangulation.

10 It is another object of the present invention to provide a cellular system that can accurately track a mobile unit within the geographic area covered by the cellular system.

It is another object of the present invention to provide a cellular system that can assess charges for calls based on the geographic location of the call.

Disclosure of Invention

15 These, and other, objects are achieved by a cellular system that makes switching and call management decisions based on the location of a mobile unit rather than on the strength of the signal associated with that mobile unit. The exact location of each mobile unit is determined using a Global Positioning System (GPS), LORAN, triangulation, or other position  
20 determining system. The NAVSTAR global positioning system, or GPS, is a system employing ultimately eighteen satellites in twelve hour orbits of 55° inclination. The system is being implemented by the Department of Defense for military use.  
25 However, it has a "clear access" (C/A) channel that is available for general civil use. The GPS is a passive navigation system on the part of the user, in that only reception of satellite-transmitted signals is required by the user to compute position. The GPS provides a capability for  
30 continuous position determination, and a position can be computed on the order of every second of time, and thus provides a capability of determining the position of a highly mobile vehicle. A full discussion of the GPS is presented in textbooks, such as "Handbook of Modern Electronics and  
35 Electrical Engineering," edited by Charles Belove and published in 1986 by Wiley-Interscience (see chapter 54 thereof, the disclosure of which is incorporated herein by reference), and includes a satellite positioned in a geostationary orbit and communicating with ground-based receivers. Based on the signals

**SUBSTITUTE SHEET (RULE 26)**



received from the satellite, the exact position in longitude and latitude, of the ground-based receiver can be determined with an extremely high degree of accuracy and precision.

The exact longitude and latitude of the mobile unit is  
5 then communicated to the MTSO, and the cell site that services that particular position is signalled by the MTSO to carry the call associated with the mobile unit. The position of the mobile unit is constantly updated, and call management decisions, such as handoffs, can be made based on the location  
10 of the mobile unit rather than the strength of the signal associated with that unit. The MTSO has a look-up table in its data storage facilities that compares positional data from the mobile units to data associated with cell site coverage areas. Based on a look up in this table, the MTSO can select the cell  
15 site most appropriate to a call.

Since the position of the mobile unit is known to the MTSO, the assessment of message units, taxes, and other charges can be made. The billing will be more consistent than is possible with present systems. Of course, call routing will be  
20 greatly improved in the system of the present invention as compared to prior systems.

Still further, since call management decisions are made based on position of the mobile unit, the number of cell sites can be reduced as communication is not subject to vagaries of  
25 weather or the like to the degree that call management decisions based on signal strength are. Even with the reduced number of cell sites, the quality of calls using such a system is improved due to proper handoff. The system is quite flexible, and cell site placement and frequency reuse are  
30 extremely efficient since call management is much more precise than in systems that use signal strength to make call management decisions.

The cellular system of the present invention in which call management decisions are made based on position of the mobile  
35 unit can reduce or eliminate the provision of cellular service beyond the authorized area, in effect reducing the interference to and from neighboring cellular carriers (reduction of inter-system interference) and more precisely define the inter-system service boundaries and handoff parameters. This system also

**SUBSTITUTE SHEET (RULE 26)**

permits precise definition of service boundaries for individual cell sites thereby allowing for greater system control and the reduction of intra-system interference. Still further, accurate and detailed cell site usage and traffic pattern data can be developed in the present system, thereby enabling accurate and precise control of system growth. The present cellular system can also be real-time tailored based on current cellular use.

Brief Description of Drawings

Figure 1 illustrates a geographic area divided into a multiplicity of cells.

Figure 2 illustrates a typical prior art mobile cellular telephone and its link with a fixed cell site and an MTSO.

Figure 3 illustrates the mobile unit of the cellular telephone system shown in Figure 2.

Figure 4 illustrates a typical prior art cellular system in which a mobile unit can be connected with a fixed-position unit.

Figure 4A is a block diagram showing systems included in the MTSO shown in Figure 4.

Figure 5 is a flow diagram of a call originated by the PTSN (public service telephone network) and a mobile unit using a prior art cellular system.

Figure 6 is a block diagram of a mobile unit of a cellular telephone system which incorporates a GPS location determining system embodying the present invention.

Figure 7 illustrates a cellular system incorporating a GPS position locating system for a mobile unit communicating with other units, such as the fixed-position unit shown.

Figure 7A is a block diagram showing systems included in the MTSO shown in Figure 7.

Figure 8 is a block diagram illustrating the cellular system embodying the present invention.

Figure 9 illustrates a look-up table that is incorporated into the MTSO of the present invention to make call management decisions based on the location of a mobile unit.

Figure 10 is a block diagram illustrating a landline-to-mobile unit call in which position data are exchanged between the mobile unit and the MTSO.

Figures 11A and 11B comprise a flow chart illustrating a

**SUBSTITUTE SHEET (RULE 26)**

call sequence between a mobile unit and another unit in which switching decisions are made based on the position of the mobile unit rather than the strength of the signal associated with the mobile unit.

5           Figure 12 illustrates a method of locating a mobile unit using triangulation, with the location being used to make call management decisions.

Best Mode for Carrying out the Invention

10           Shown in Figures 6, 7 and 7A is a cellular system 20 embodying the present invention. The cellular system 20 uses positional data associated with the mobile unit M' to make call management decisions. To this end, the cellular system 20, while similar in all other respects to the cellular system illustrated in Figures 2 and 3, includes means for accurately and precisely determining the exact position of the mobile unit 15 M', and then further includes means for using this positional information to determine which cell site is best suited to handle a call associated with that mobile unit M'.

20           The means for accurately determining the precise position of the mobile unit includes a Global Positioning System. The GPS includes satellites, such as satellite 22 in orbit about the earth. Each mobile unit further includes a GPS receiver 24 located between the duplexer and the logic circuitry 25 of the mobile unit. The GPS receiver communicates with the satellite 22 and the exact longitude and latitude of the mobile unit are determined. This information is sent to the MTSO via a cell site, and the MTSO uses a look-up table such as disclosed in Figure 9, containing the geographic location of each cell site in the cellular system, to determine which cell 25 site is most appropriate for use by the mobile unit. The mobile unit communicates with cell sites using unused bits of the aforesaid overhead messages to send its positional information to the MTSO when the mobile unit is first activated. This positional information is relayed to the MTSO 30 by the first cell site to communicate with the mobile unit. The MTSO then selects the cell site most appropriate for the mobile unit and hands that mobile unit off to that cell site. The cell sites transmit system service boundaries in their overhead messages that are interpreted by mobile units. The mobile units 35

**SUBSTITUTE SHEET (RULE 26)**

use the location information supplied by the GPS receiver as opposed to signal strength to determine which system to originate on. Call termination can utilize the paging process as is currently utilized. A response from a mobile unit  
5 includes the location information, and the designated control channel instructs the mobile unit to tune to one of its channels. A call in progress utilizes the overhead message of the voice channel to communicate location information. Once a mobile unit that is call processing on a particular site  
10 crosses a cell boundary, it is instructed to perform a handoff to the cell that is to service the new location. It is understood that the GPS is used as an example of the preferred source of positional data; however, other sources similar to the GPS can be used without departing from the scope of the present invention. All that is required is that the source of  
15 positional data be able to generate precise and accurate locational data on a fixed or a rapidly moving object. It is also helpful, but not absolutely required, that the CMR be only passively involved in the determination of the positional data.

20 The handoff process is similar to the present handoff processes, except it will be controlled according to position of the mobile unit instead of signal strength. This position information is used to determine call rating and taxing for billing purposes and call routing to make sure that the proper  
25 services for that location are provided.

A "locate request" signal is not used, since the exact location of the mobile unit is known to the MTSO. However, as indicated in Figure 8, a signal strength method can also be used in making call management decisions if suitable. Such a  
30 process would be used if the mobile unit moves into a prior art cellular system.

A call using the cellular system of the present invention is illustrated in Figure 11. Initial communication between a mobile unit and the MTSO is established using the overhead  
35 communication network described above. The mobile unit scans marker channels and initially locks onto the cell site that has the strongest signal. This cell site may not be the most appropriate cell site for use by that mobile unit, but it serves as an entrè into the system. Once this initial

**SUBSTITUTE SHEET (RULE 26)**

communication is established, the mobile unit uses the GPS receiver 24 and GPS satellite 22 and to determine its exact longitude and latitude. This information is then relayed to the MTSO using the originating cell site. The MTSO uses this  
5 information in conjunction with a look-up table such as shown in Figure 9 to establish communication between the mobile unit and the cell site most appropriate to that mobile unit. The mobile unit is then handed off to that cell site. A call initiated by that mobile unit is routed through the appropriate  
10 cell site.

As indicated in Figure 11, business information associated with the call, can be recorded at the MTSO. As indicated in Figure 10, the dotted lines represent data transmission that contains GPS information. It is also noted that since both a  
15 position controlled system and a signal strength system are included in the cellular system of the present invention, the MTSO can include a software system in the memory 30 shown in Figure 8 to use the position controlled system, but to also test signal strength, and to use a signal strength controlled  
20 system if a signal still falls below a predetermined value when making call management decisions based on the position of the mobile unit. In this manner, the best of both systems can be obtained.

The system of the present invention can also be used to  
25 allow a mobile to place calls only on its home system at the decision of the mobile. The mobile locating features of the system could also be important in other contexts, such as emergencies or the like.

The use of triangulation is another means of providing  
30 mobile location information to the MTSO for the purpose of making intelligent switch management decisions based on the exact geographic location of the mobile unit. This method is illustrated in Figure 12, and allows the MTSO to determine the exact location of a mobile cellular telephone MCT by using the  
35 received mobile signal S1, S2 and S3 from three or more cell sites E, F, and G, respectively. Through the precise timing of the received signal at three or more sites, the MTSO can then determine the exact location of the mobile phone in relation to the intended coverage area of each given cell site in the

**SUBSTITUTE SHEET (RULE 26)**

system. The MTSO can include circuits to compensate for the time delay difference between sites of the received mobile signal and use those signals to determine the distance from each site. The system also includes a computer that can locate the mobile location in relation to the geographic size of each cell site.

The MTSO will have a set of look-up tables, as does the previously proposed system in the parent application, that are used to determine the shape and location of the individual cell sites.

Like the GPS system disclosed in the parent application, if the MTSO fails to receive exact mobile location information by either the triangulation system or from the GPS data, the MTSO can then default to the original method of making cell site decisions based simply on signal strength alone.

It is understood that while certain forms of the present invention have been illustrated and described herein, it is not to be limited to the specific forms or arrangements of parts described and shown.

**SUBSTITUTE SHEET (RULE 26)**

## CLAIMS

1. A wireless radio communications system such as a cellular telephone, that includes one or more cell sites and one or more mobile telephone switching offices (MTSO), said system comprising:
- 5           A) locating means in a radio communications system for determining the exact geographic location of a mobile unit; and
- B) means in the MTSO for making call management decisions based on the geographic location of the mobile unit, said
- 10 management means including means for storing the geographic location, shape and size of each cell site in the communications system and for comparing the exact geographic location of the mobile unit to the geographic location of each cell site and for selecting a cell site for use by the mobile
- 15 unit based on such comparison.
2. A method of making call management decisions in a cellular telephone system having a plurality of cell sites at various geographic locations and an MTSO in which the geographic location of each cell site in the cellular telephone system has
- 20 been stored, the method comprising steps of:
- A) establishing an exact geographic location for a mobile unit using triangulation;
- B) matching the geographic location of the mobile unit to a cell site geographic location, and selecting a cell site based
- 25 on such matching; and
- C) using the selected cell site matched to the mobile unit to handle calls associated with the mobile unit.
3. The method defined in Claim 2 further including a step of handing off the mobile unit to a second cell site based on the
- 30 position of the mobile unit.
4. The system defined in Claim 1 further including means for placing location data on existing voice and data communication signals.
5. The method defined in Claim 2 further including a step of
- 35 continuously monitoring the position of the mobile unit as the mobile unit moves, and handing off the mobile unit to various cell sites based on instantaneous location of the mobile unit.
6. The method defined in Claim 2 further including a step of assessing message unit charges on calls made to or from a

**SUBSTITUTE SHEET (RULE 26)**

mobile unit based upon the geographic location of the mobile unit.

7. A method of making call management decisions in a cellular telephone system having a plurality of cell sites at various geographic locations and means in which the geographic location of each cell site in the cellular telephone system has been stored, the method comprising steps of:

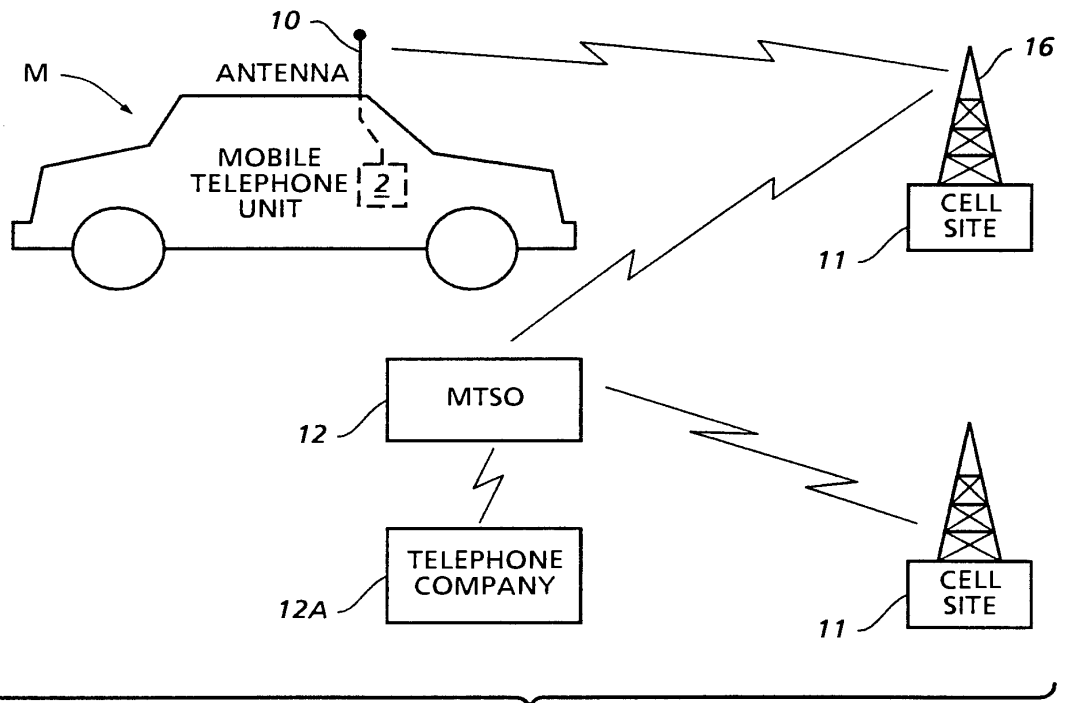
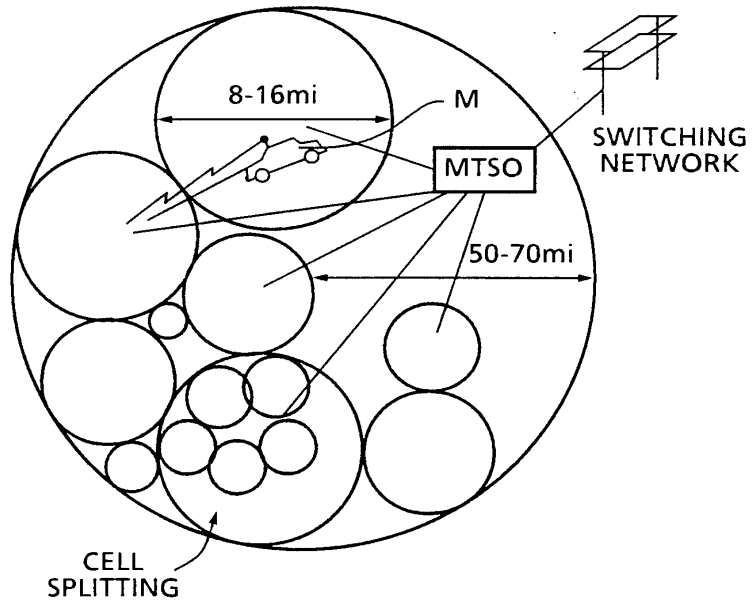
- A) establishing an exact geographic location for a mobile unit;
- 10 B) matching the geographic location of the mobile unit to a cell site geographic area and selecting a cell site based on such matching; and
- C) using the selected cell site matched to the mobile unit to handle calls associated with the mobile unit.

**SUBSTITUTE SHEET (RULE 26)**



- 1 / 14

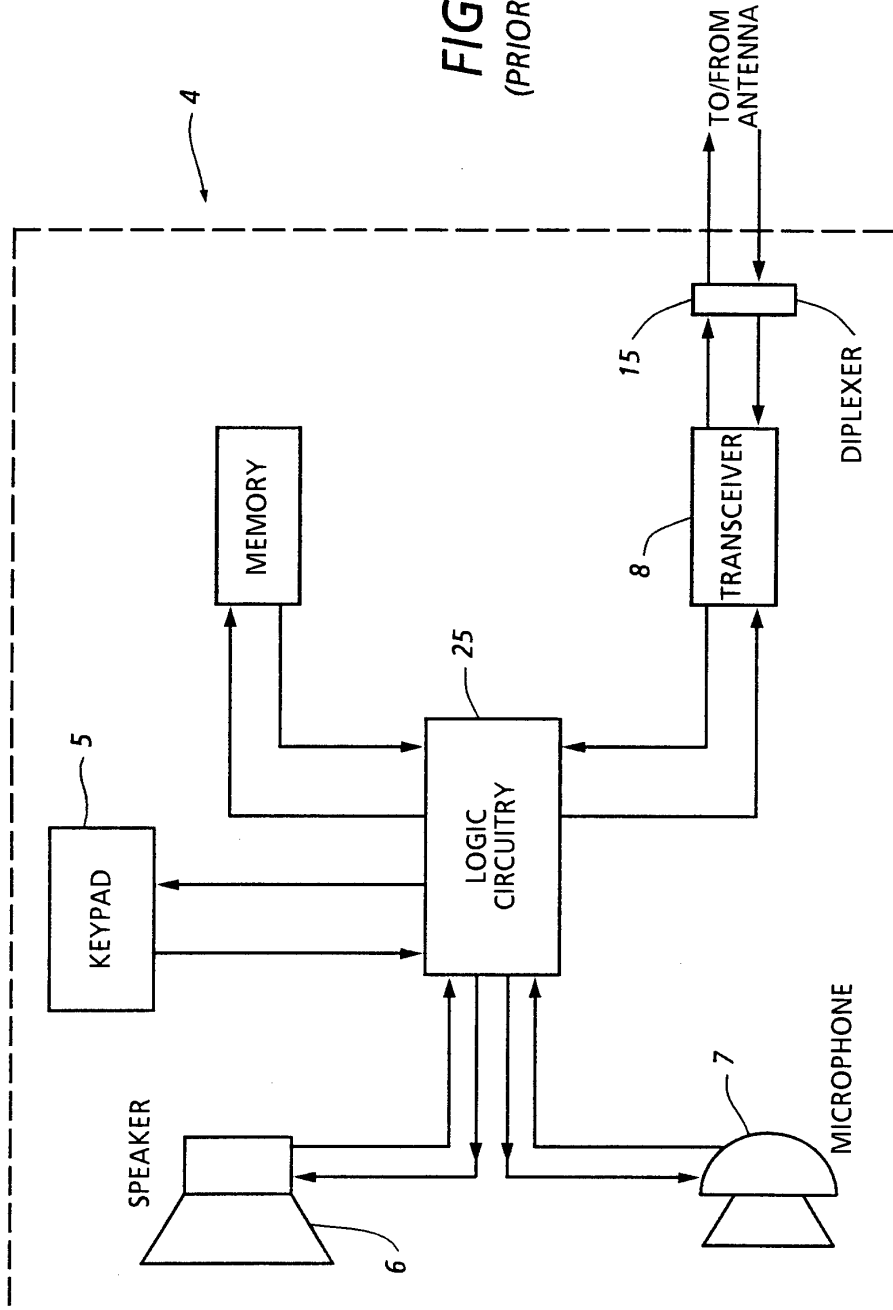
**FIG. 1**  
(PRIOR ART)



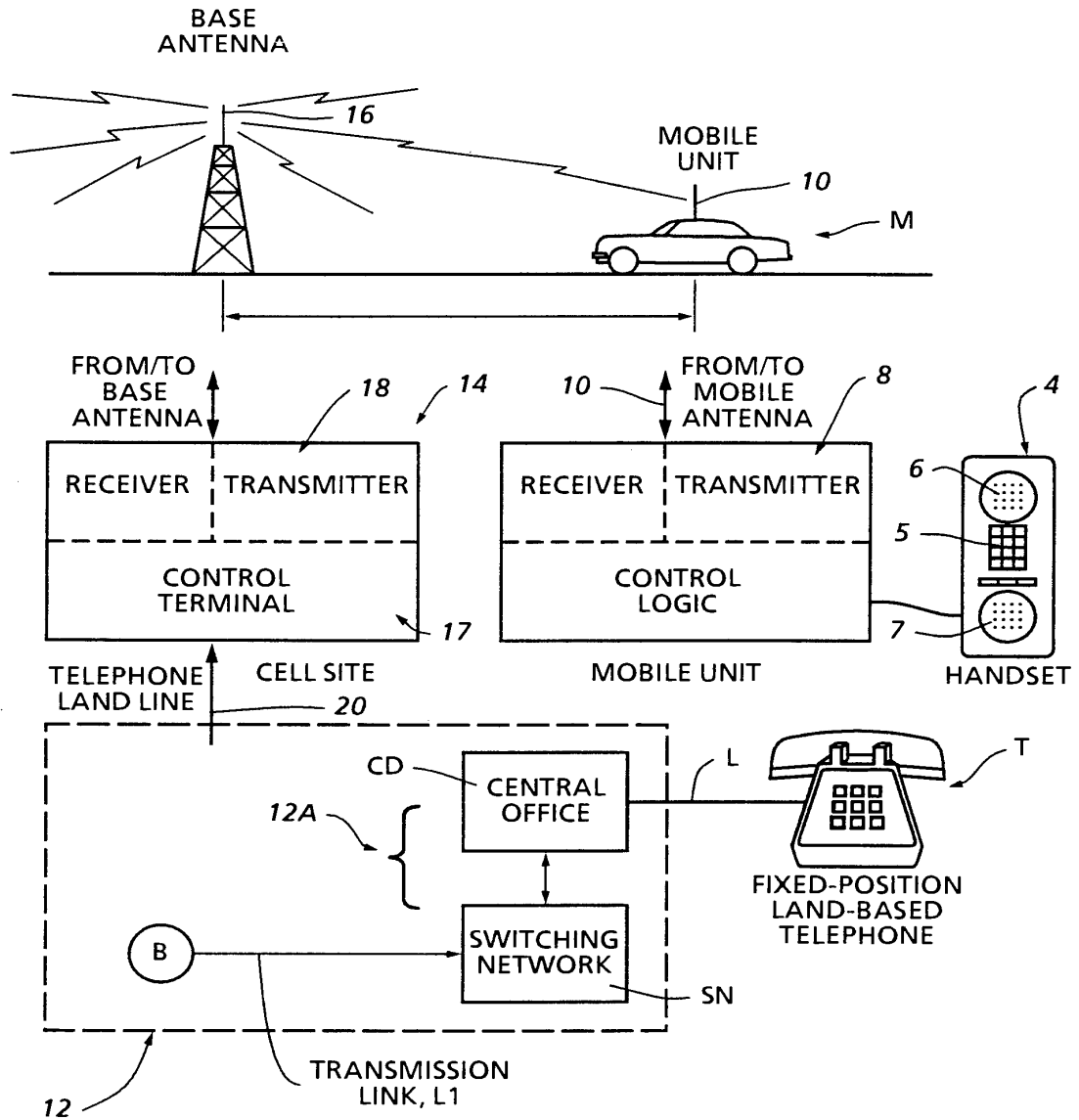
**FIG. 2**  
(PRIOR ART)

**SUBSTITUTE SHEET (RULE 26)**

FIG. 3  
(PRIOR ART)



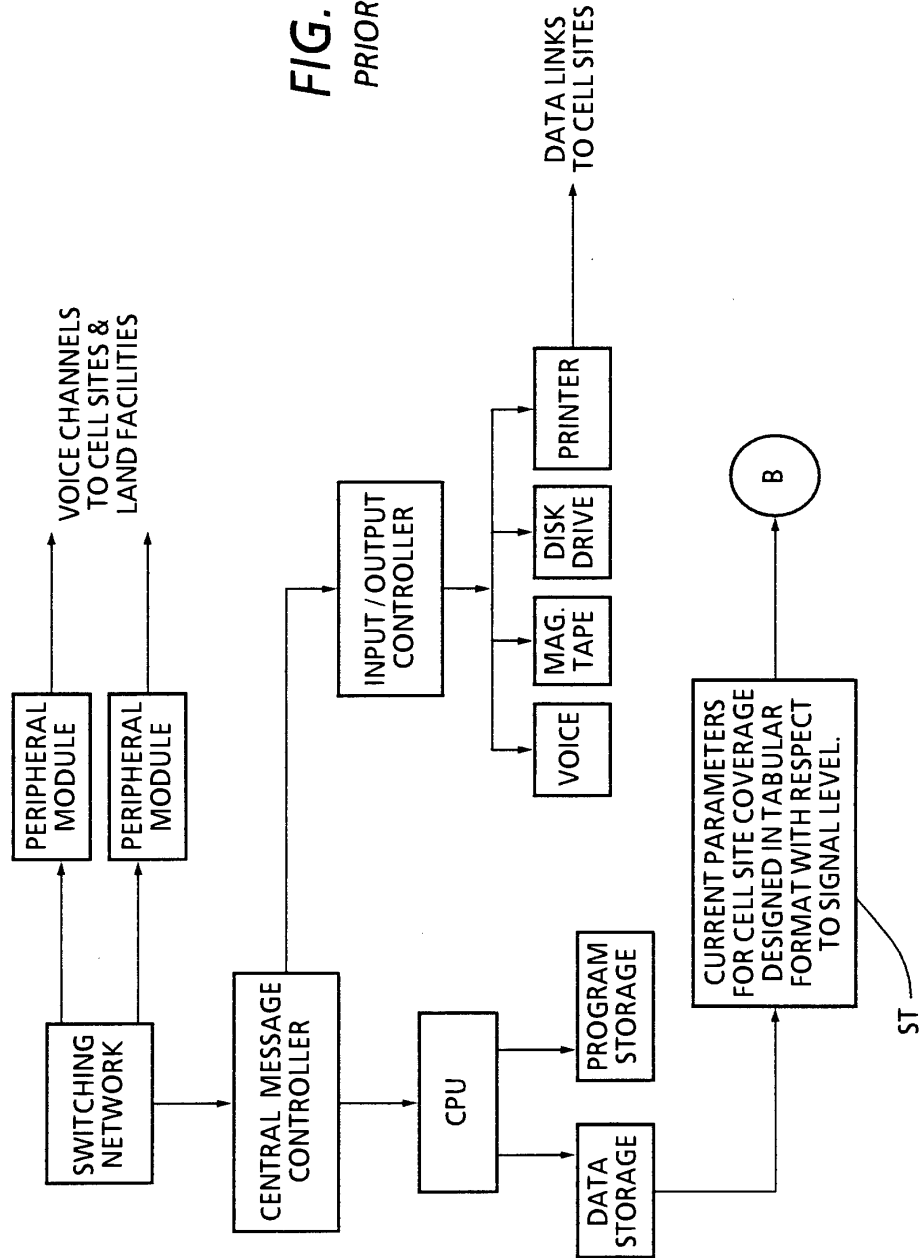
SUBSTITUTE SHEET (RULE 26)



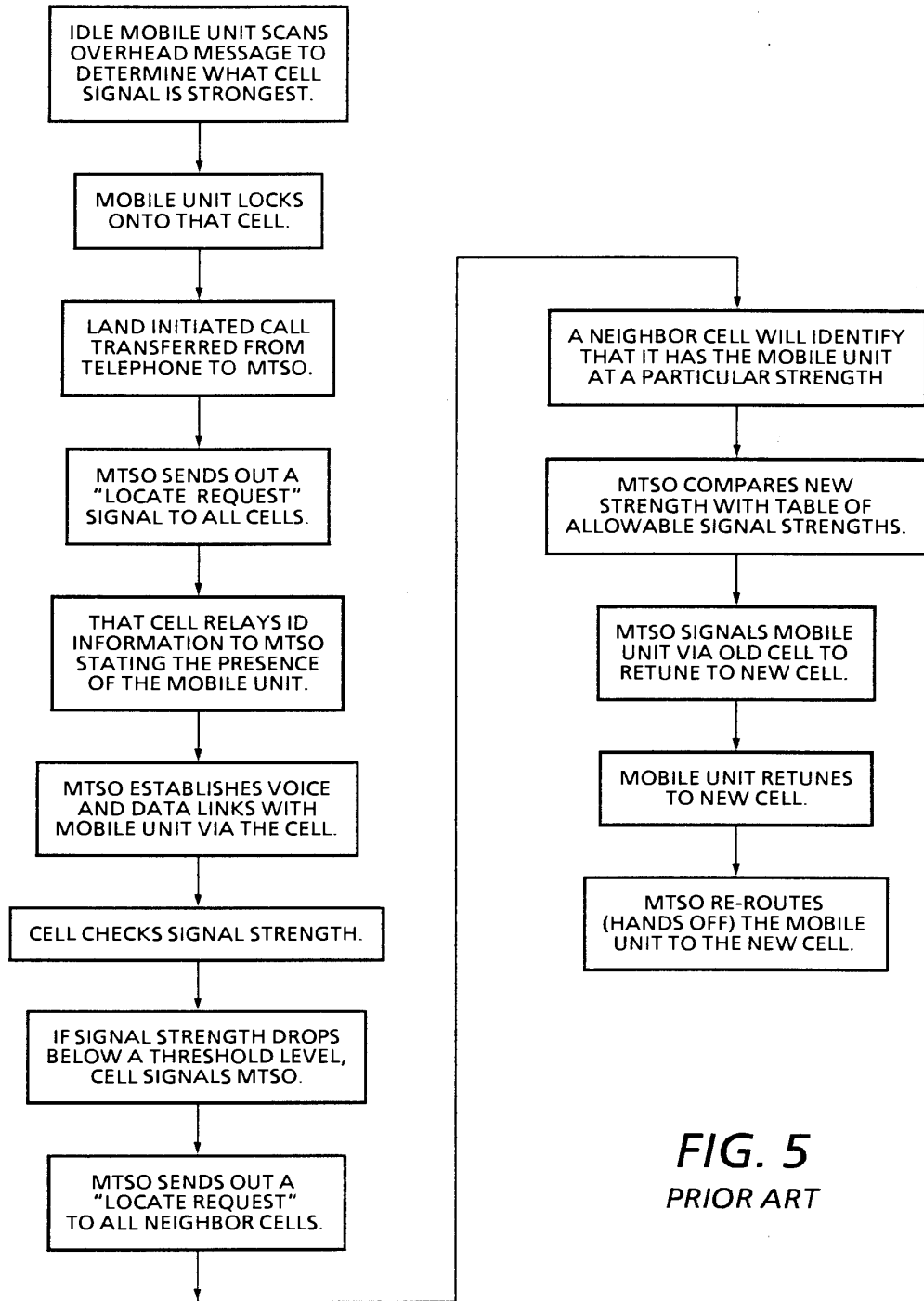
**FIG. 4**  
(PRIOR ART)

**SUBSTITUTE SHEET (RULE 26)**

FIG. 4A  
PRIOR ART



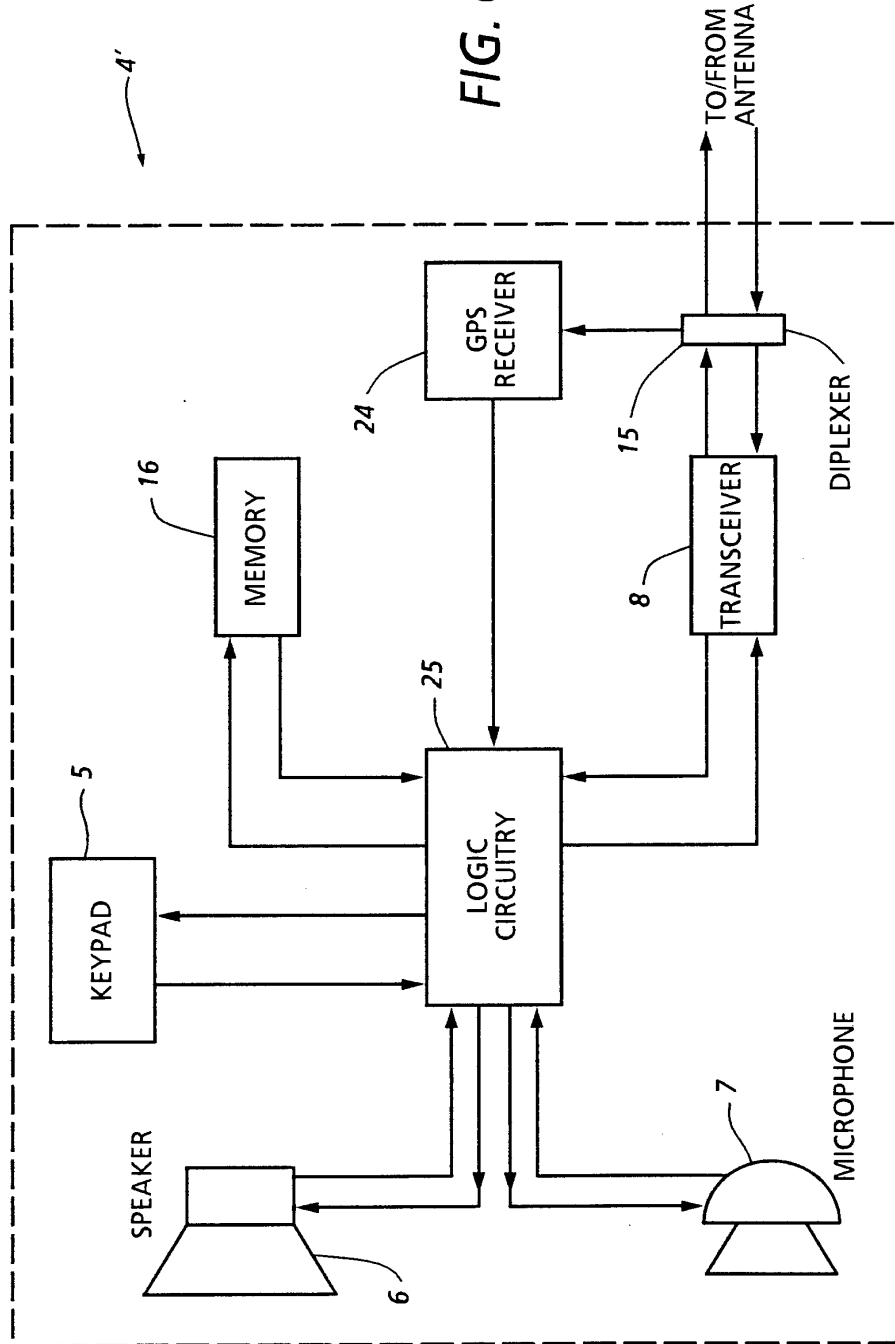
SUBSTITUTE SHEET (RULE 26)



**FIG. 5**  
PRIOR ART

SUBSTITUTE SHEET (RULE 26)

FIG. 6



SUBSTITUTE SHEET (RULE 26)

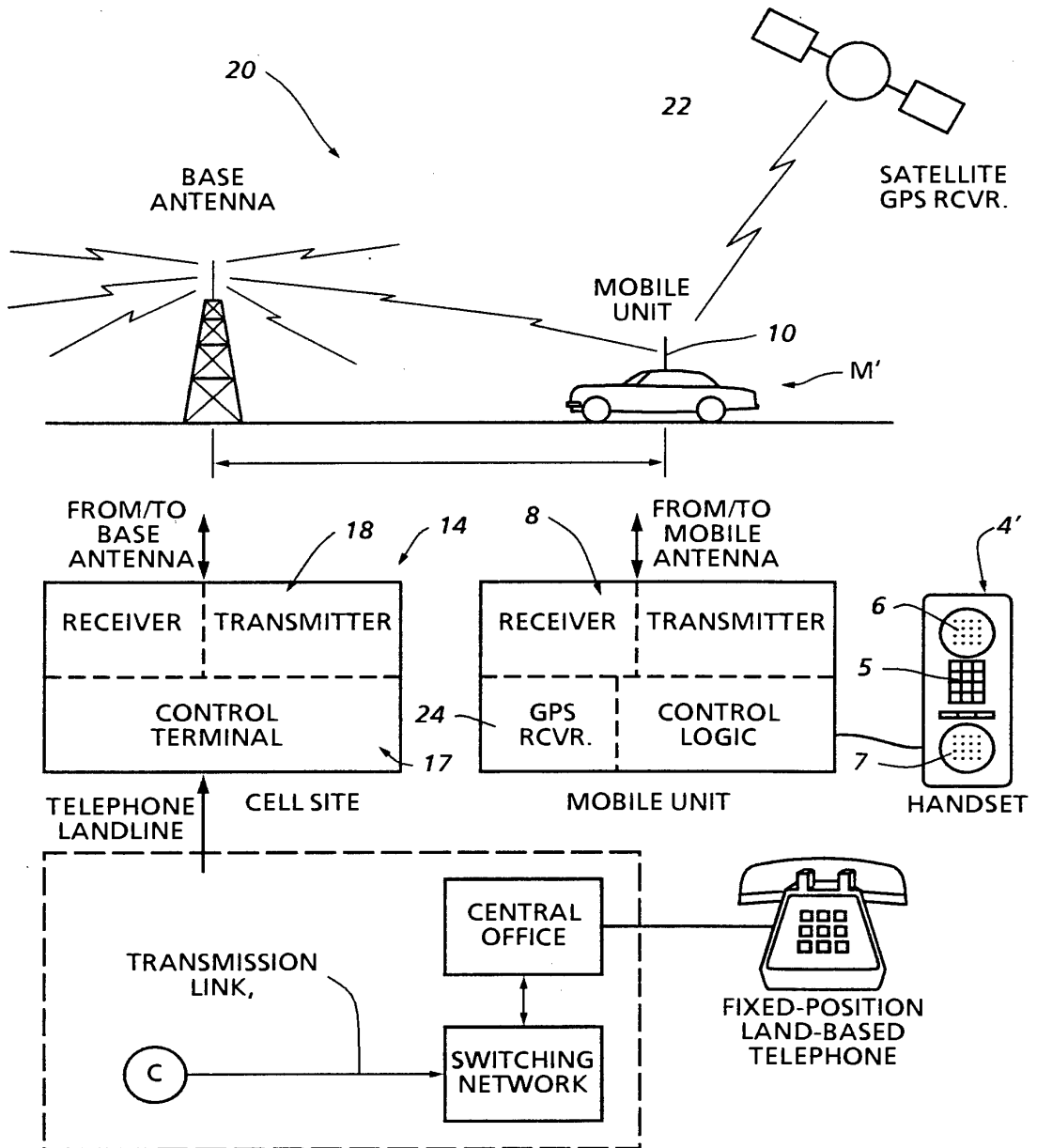


FIG. 7

SUBSTITUTE SHEET (RULE 26)

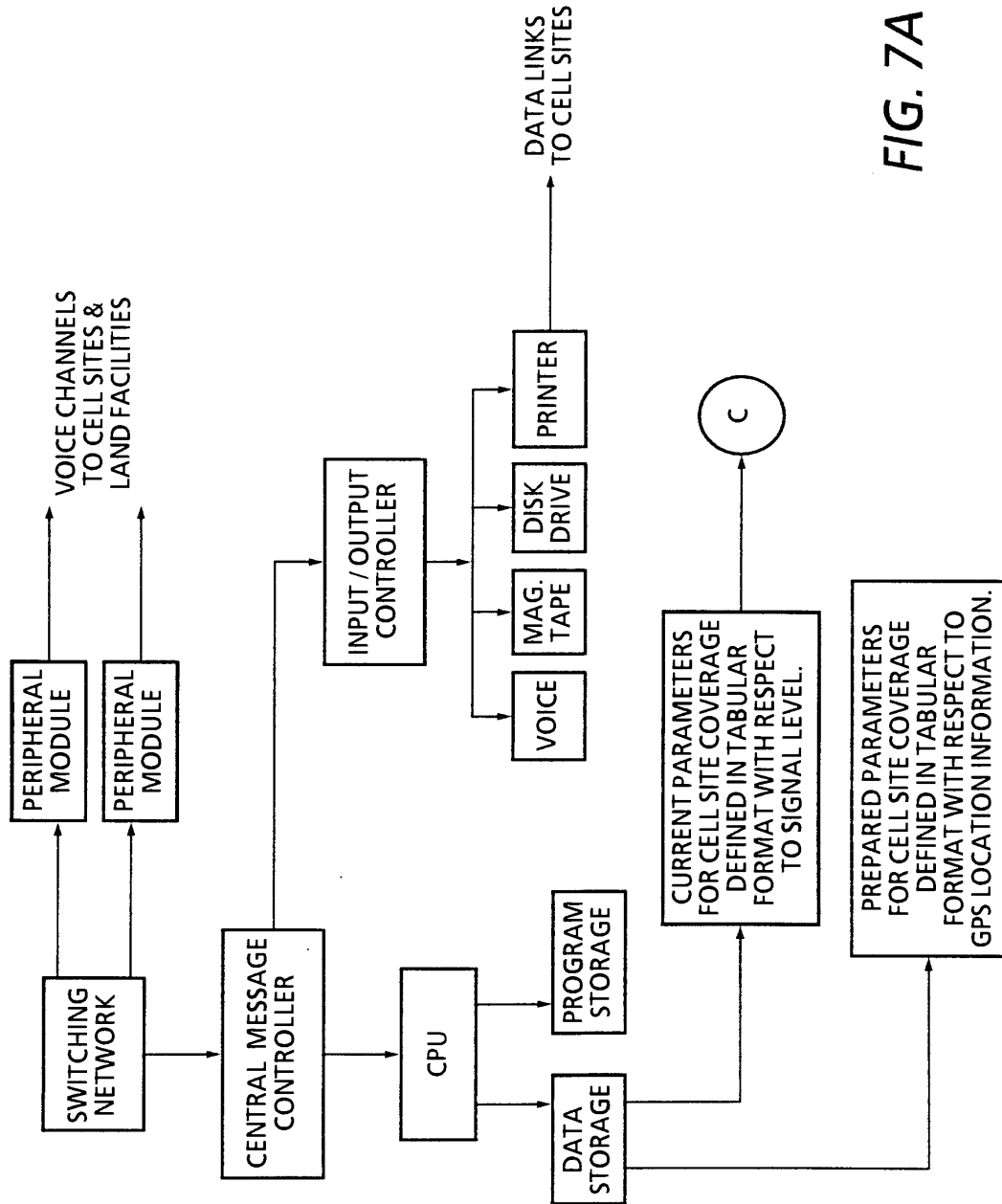


FIG. 7A

SUBSTITUTE SHEET (RULE 26)



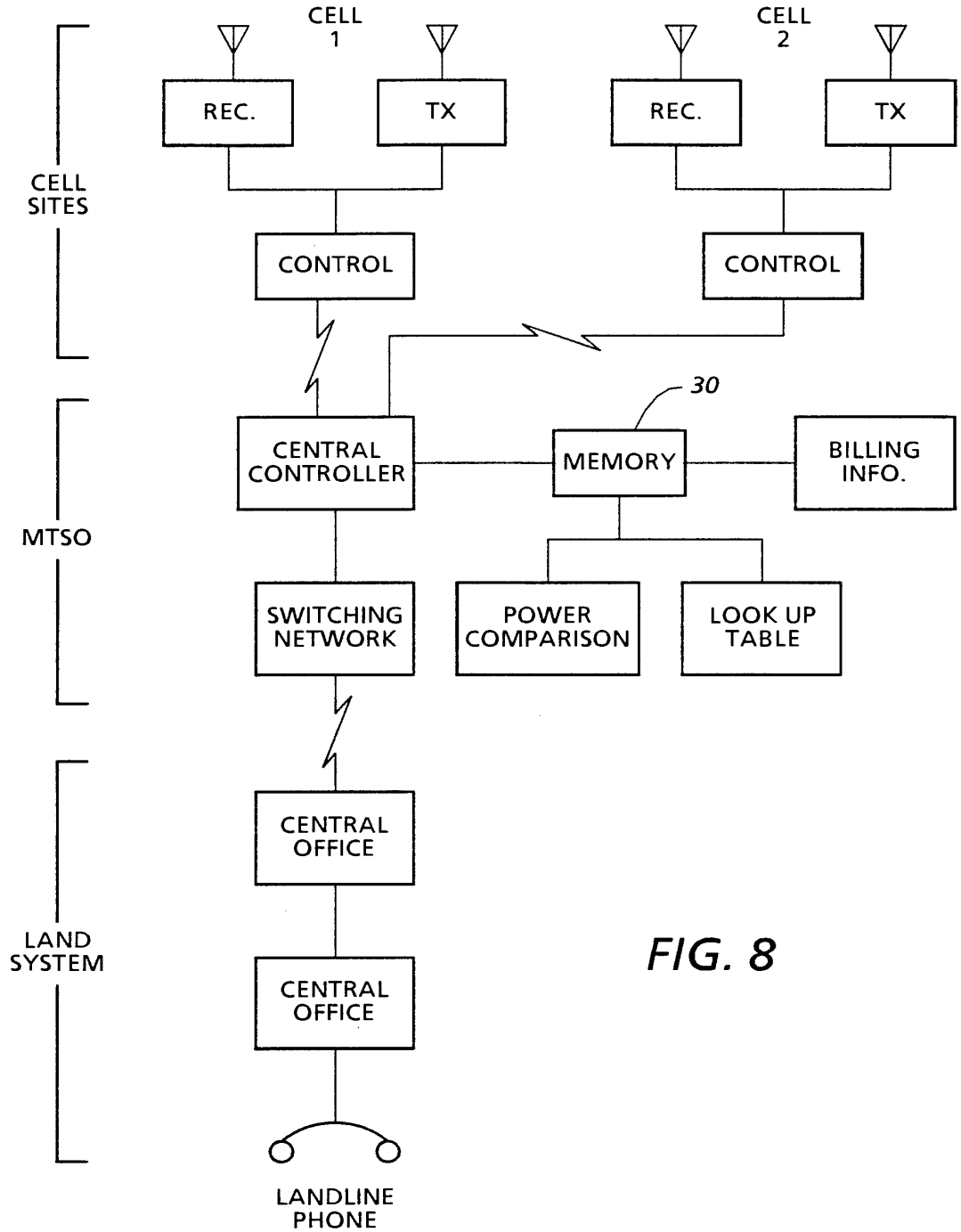


FIG. 8

SUBSTITUTE SHEET (RULE 26)



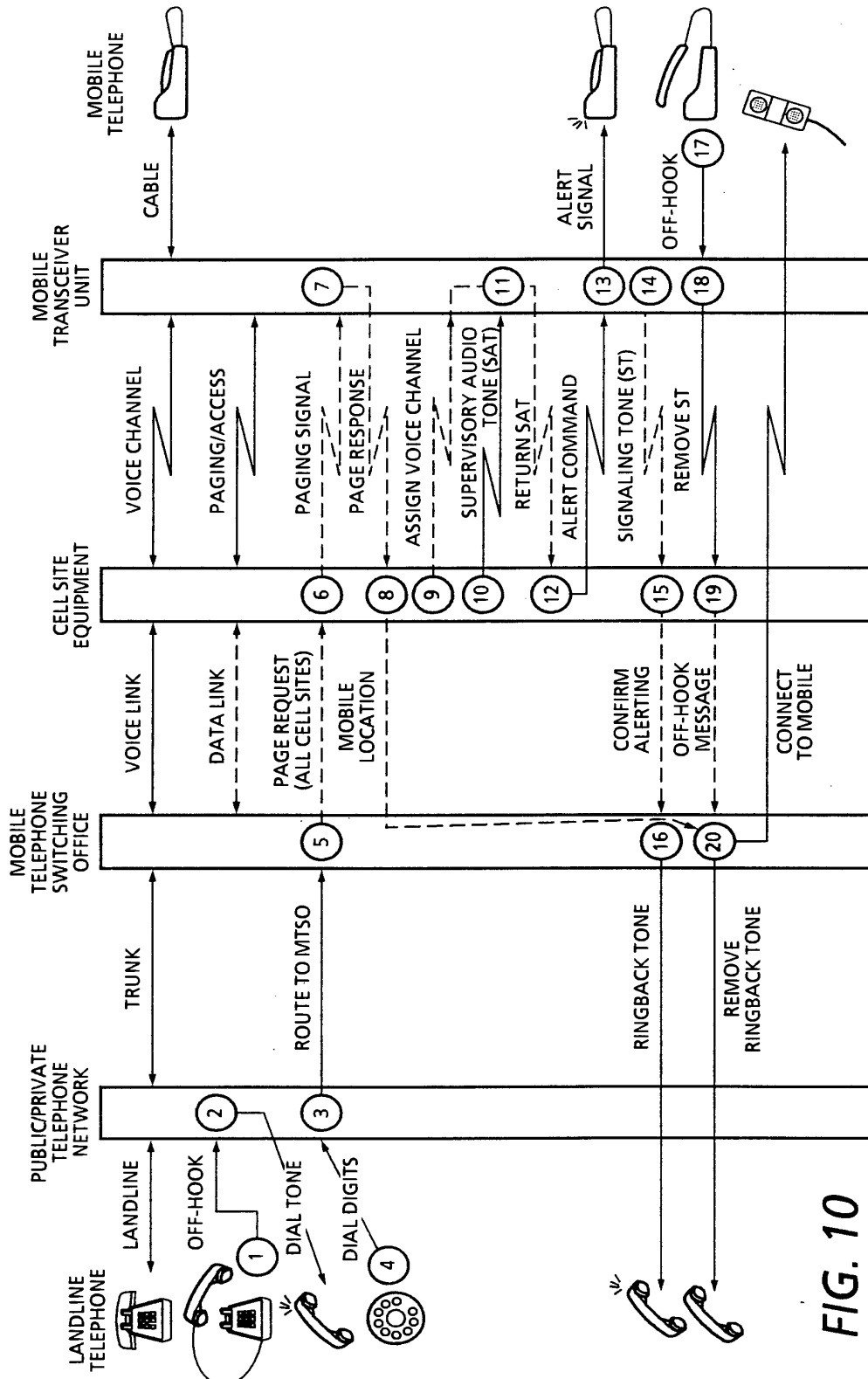


FIG. 10

SUBSTITUTE SHEET (RULE 26)

12 / 14

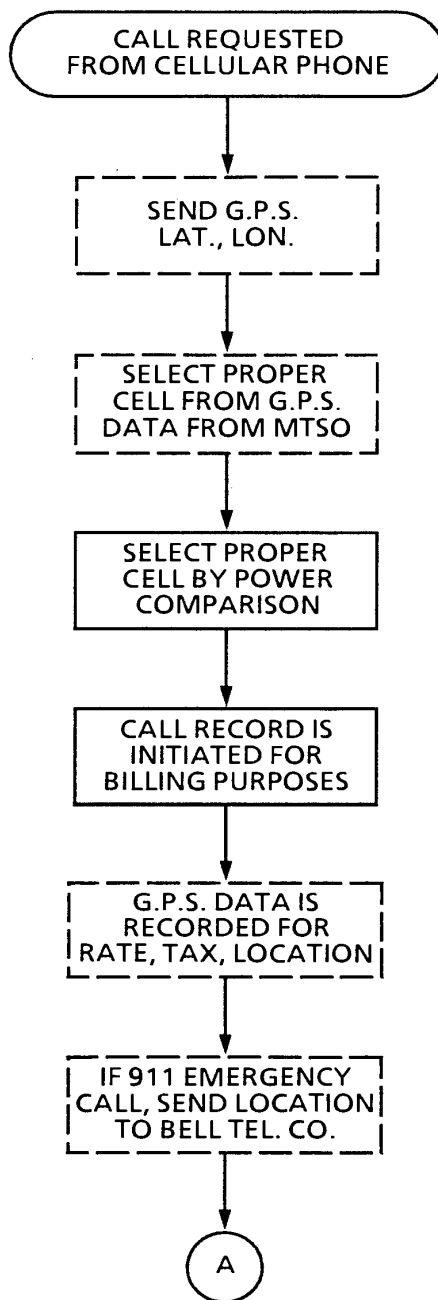


FIG. 11A

SUBSTITUTE SHEET (RULE 26)

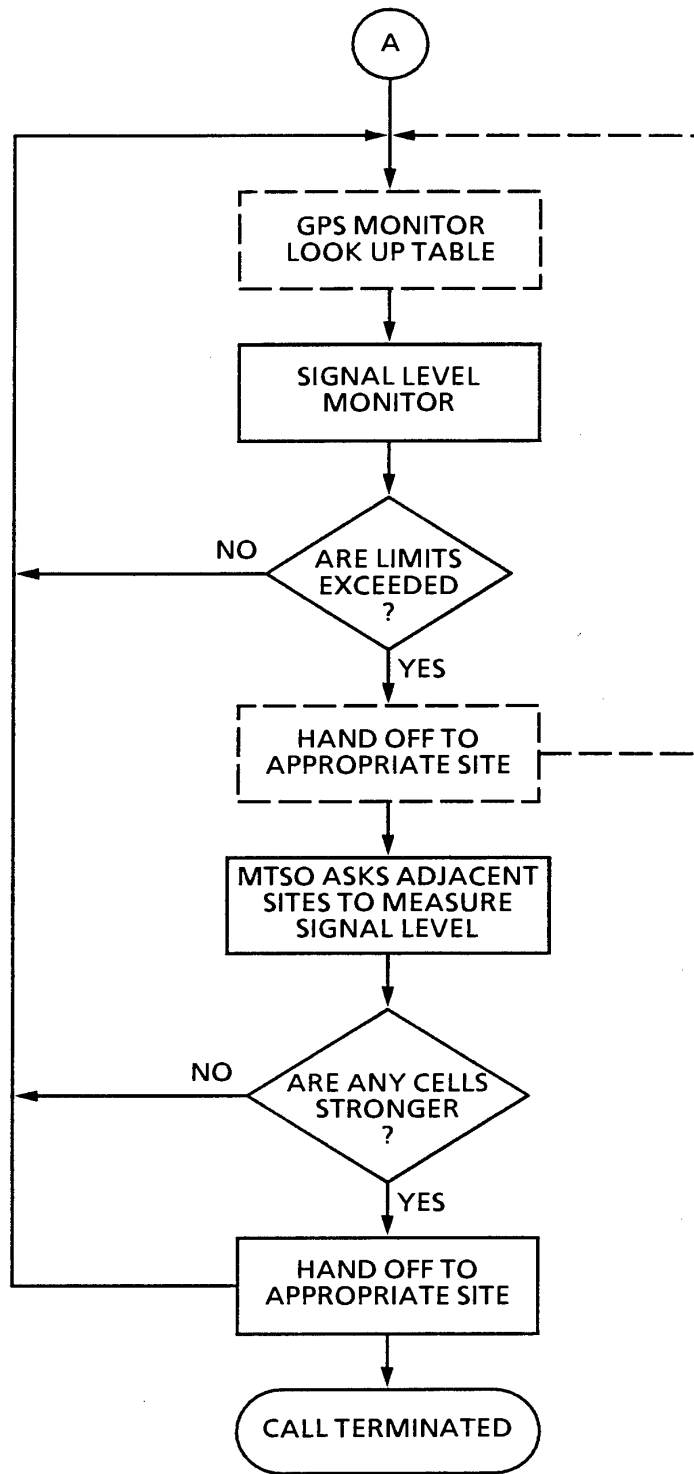
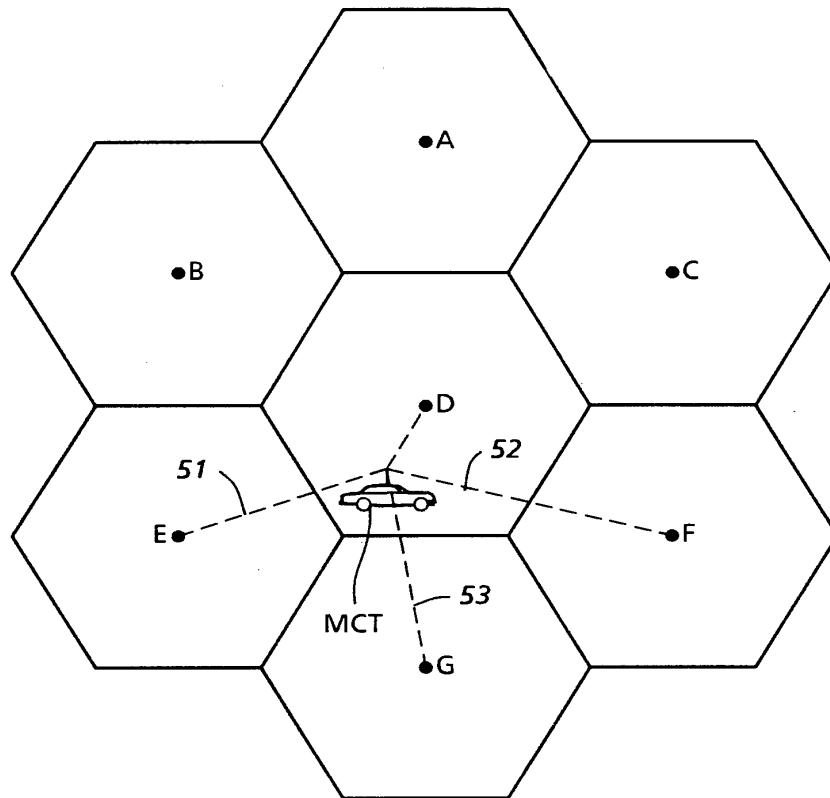


FIG. 11B

SUBSTITUTE SHEET (RULE 26)



**FIG. 12**

**SUBSTITUTE SHEET (RULE 26)**

INTERNATIONAL SEARCH REPORT

International application No.  
PCT/US94/04500

| <b>A. CLASSIFICATION OF SUBJECT MATTER</b>   |  |   |  |  |
|--|--|---|--|--|
| IPC(5) :H04M 11/06<br>US CL :379/60; 455/33.2<br>According to International Patent Classification (IPC) or to both national classification and IPC   |  |   |  |  |
| <b>B. FIELDS SEARCHED</b>  |  |   |  |  |
| Minimum documentation searched (classification system followed by classification symbols)<br>U.S. : 379/59, 60; 455/33.1, 33.2, 33.4; 342/450, 457   |  |   |  |  |
| Documentation searched other than minimum documentation to the extent that such documents are included in the fields searched<br>none  |  |   |  |  |
| Electronic data base consulted during the international search (name of data base and, where practicable, search terms used)<br>APS<br>search terms: triangulat7, (cellular or mobile or radio), (telephone or phone), radiotelephone  |  |   |  |  |
| <b>C. DOCUMENTS CONSIDERED TO BE RELEVANT</b>  |  |   |  |  |
| Category*  | Citation of document, with indication, where appropriate, of the relevant passages   | Relevant to claim No.   |  |  |
| Y  | US, A, 4,144,411 (FRENKIEL) 13 March 1979; see column 5, lines 6-17.   | 1-3, 5-7  |  |  |
| Y,P  | US, A, 5,235,633 (DENNISON et al.) 10 August 1993; see entire document.  | 1-3, 5-7  |  |  |
| Y,P  | US, A, 5,214,789 (GEORGE) 25 May 1993; see Abstract, column 2, lines 1-16 and 36-38.   | 1, 2, 7   |  |  |
| Y,E  | US, A, 5,321,514 (MARTINEZ) 14 June 1994; see Abstract; column 8, lines 24-32, 38-44; column 28, lines 38-45, 59-64.   | 1, 2, 7   |  |  |
| <input type="checkbox"/> Further documents are listed in the continuation of Box C. <input type="checkbox"/> See patent family annex.  |  |   |  |  |
| * Special categories of cited documents: <table border="0" style="width:100%"> <tr> <td style="width:50%">           *A* document defining the general state of the art which is not considered to be part of particular relevance<br/>           *E* earlier document published on or after the international filing date<br/>           *L* document which may throw doubts on priority claim(s) or which is cited to establish the publication date of another citation or other special reason (as specified)<br/>           *O* document referring to an oral disclosure, use, exhibition or other means<br/>           *P* document published prior to the international filing date but later than the priority date claimed         </td> <td style="width:50%">           *T* later document published after the international filing date or priority date and not in conflict with the application but cited to understand the principle or theory underlying the invention<br/>           *X* document of particular relevance; the claimed invention cannot be considered novel or cannot be considered to involve an inventive step when the document is taken alone<br/>           *Y* document of particular relevance; the claimed invention cannot be considered to involve an inventive step when the document is combined with one or more other such documents, such combination being obvious to a person skilled in the art<br/>           *&amp;* document member of the same patent family         </td> </tr> </table> |  |   | *A* document defining the general state of the art which is not considered to be part of particular relevance<br>*E* earlier document published on or after the international filing date<br>*L* document which may throw doubts on priority claim(s) or which is cited to establish the publication date of another citation or other special reason (as specified)<br>*O* document referring to an oral disclosure, use, exhibition or other means<br>*P* document published prior to the international filing date but later than the priority date claimed | *T* later document published after the international filing date or priority date and not in conflict with the application but cited to understand the principle or theory underlying the invention<br>*X* document of particular relevance; the claimed invention cannot be considered novel or cannot be considered to involve an inventive step when the document is taken alone<br>*Y* document of particular relevance; the claimed invention cannot be considered to involve an inventive step when the document is combined with one or more other such documents, such combination being obvious to a person skilled in the art<br>*&* document member of the same patent family |
| *A* document defining the general state of the art which is not considered to be part of particular relevance<br>*E* earlier document published on or after the international filing date<br>*L* document which may throw doubts on priority claim(s) or which is cited to establish the publication date of another citation or other special reason (as specified)<br>*O* document referring to an oral disclosure, use, exhibition or other means<br>*P* document published prior to the international filing date but later than the priority date claimed   | *T* later document published after the international filing date or priority date and not in conflict with the application but cited to understand the principle or theory underlying the invention<br>*X* document of particular relevance; the claimed invention cannot be considered novel or cannot be considered to involve an inventive step when the document is taken alone<br>*Y* document of particular relevance; the claimed invention cannot be considered to involve an inventive step when the document is combined with one or more other such documents, such combination being obvious to a person skilled in the art<br>*&* document member of the same patent family |   |  |  |
| Date of the actual completion of the international search<br>14 JUNE 1994  |  | Date of mailing of the international search report<br>SEP 08 1994 |  |  |
| Name and mailing address of the ISA/US<br>Commissioner of Patents and Trademarks<br>Box PCT<br>Washington, D.C. 20231<br>Facsimile No. (703) 305-3230  |  | Authorized officer<br>Dwayne Bost<br>Telephone No. (703) 305-4778 |  |  |

Form PCT/ISA/210 (second sheet)(July 1992)\*

(12)

(21) 2 325 644

(51) Int. Cl. 7: **H04Q 7/36**

(22) 09.11.2000

(30) 09/448,933 US 24.11.1999

(71) **LUCENT TECHNOLOGIES INC.,**  
600 Mountain Avenue, MURRAY HILL, XX (US).

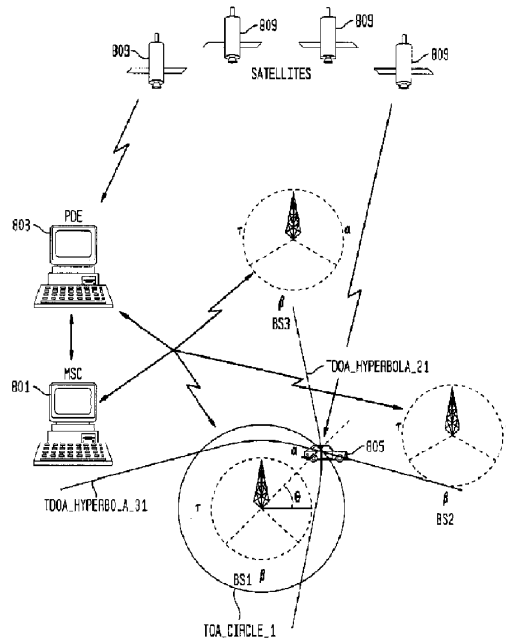
**CHIANG, TUNG CHING (US).**  
**CHEN, BYRON HUA (US).**  
**FREIDENFELDS, JOHN (US).**  
**TEKIN, IBRAHIM (US).**

(72)

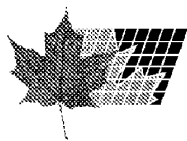
(74) **KIRBY EADES GALE BAKER**

(54) AMELIORATION DU RESEAU GRACE A L'UTILISATION DE DONNEES A REFERENCE GEOGRAPHIQUE  
(54) NETWORK ENHANCEMENT BY UTILIZING GEOLOCATION INFORMATION

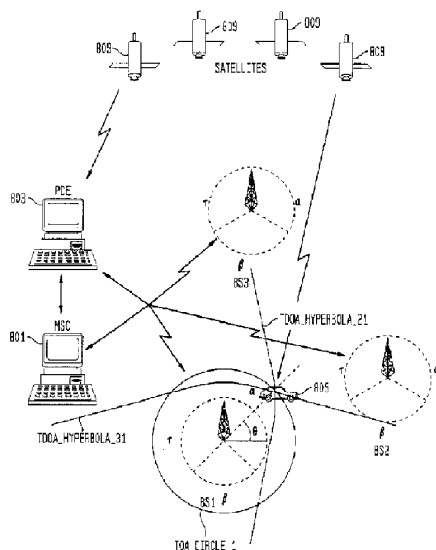
(57) Network performance of a wireless network is enhanced by using geolocation information. The network enhancement may be achieved by determining call-dropping zones by the use geolocation information and by improving the signal quality in these call-dropping zones. The network enhancement may also be achieved in the form of increased capacity and reduced interference by utilizing geolocation information in beam steering and shaping of intelligent antennas. Rather than having antennas passively steering and shaping their beams in terms of the rays coming directly from mobiles or reflected by objects, geolocation information may be used to steer the beams (i.e., when antennas are adaptive) or select particular beams (i.e., when antennas are fixed-beam). In addition, the network enhancement may be achieved by using geolocation information in downtilt technology. The network enhancement may be further achieved by using geolocation information to reduce mobile registration requirements. The network enhancement may be also achieved by better managing the power level of a mobile. Additionally, the network enhancement may be achieved by enhancing load-balancing capabilities in a wireless system by the use of geolocation information.







- (72) TEKIN, IBRAHIM, US
- (72) FREIDENFELDS, JOHN, US
- (72) CHEN, BYRON HUA, US
- (72) CHIANG, TUNG CHING, US
- (71) LUCENT TECHNOLOGIES INC., US
- (51) Int.Cl.<sup>7</sup> H04Q 7/36
- (30) 1999/11/24 (09/448,933) US
- (54) AMELIORATION DU RESEAU GRACE A L'UTILISATION DE  
DONNEES A REFERENCE GEOGRAPHIQUE
- (54) NETWORK ENHANCEMENT BY UTILIZING GEOLOCATION  
INFORMATION



(57) Network performance of a wireless network is enhanced by using geolocation information. The network enhancement may be achieved by determining call-dropping zones by the use geolocation information and by improving the signal quality in these call-dropping zones. The network enhancement may also be achieved in the form of increased capacity and reduced interference by utilizing geolocation information in beam steering and shaping of intelligent antennas. Rather than having antennas passively steering and shaping their beams in terms of the rays coming directly from mobiles or reflected by objects, geolocation information may be used to steer the beams (i.e., when antennas are adaptive) or select particular beams (i.e., when antennas are fixed-beam). In addition, the network enhancement may be achieved by using geolocation information in downtilt technology. The network enhancement may be further achieved by using geolocation information to reduce mobile registration requirements. The network enhancement may be also achieved by better managing the power level of a mobile. Additionally, the network enhancement may be achieved by enhancing load-balancing capabilities in a wireless system by the use of geolocation information.

**NETWORK ENHANCEMENT BY UTILIZING GEOLOCATION INFORMATION**

**ABSTRACT OF THE DISCLOSURE**

Network performance of a wireless network is enhanced by using geolocation information. The network enhancement may be achieved by determining call-dropping zones by the use geolocation information and by improving the signal quality in these call-dropping zones. The network enhancement may also be achieved in the form of increased capacity and reduced interference by utilizing geolocation information in beam steering and shaping of intelligent antennas. Rather than having antennas passively steering and shaping their beams in terms of the rays coming directly from mobiles or reflected by objects, geolocation information may be used to steer the beams (i.e., when antennas are adaptive) or select particular beams (i.e., when antennas are fixed-beam). In addition, the network enhancement may be achieved by using geolocation information in downtilt technology. The network enhancement may be further achieved by using geolocation information to reduce mobile registration requirements. The network enhancement may be also achieved by better managing the power level of a mobile. Additionally, the network enhancement may be achieved by enhancing load-balancing capabilities in a wireless system by the use of geolocation information.

## **NETWORK ENHANCEMENT BY UTILIZING GEOLOCATION INFORMATION**

### BACKGROUND OF THE INVENTION

#### Field of the Invention

The present invention relates to wireless communications systems.

#### Cross-Reference to Related Applications

The subject matter of this application is related to U.S. patent application no. 09/251500 filed on February 17, 1999 as attorney docket no. Chen 5-4-5-1, the teachings of which are incorporated herein by reference.

#### Description of the Related Art

The proliferation of mobile units and their technology and usage has revealed various applications for the ability to locate mobile units. These applications include "911" calls, tourist and travel information, tracking of unauthorized cell phone usage and illegal activities, and locating of commercial and government vehicles, to name a few. Conventional wireless systems can determine only the nearest base station which at best may locate a mobile unit to within a radius of 3 to 10 miles. However, FCC regulations, as dictated in FCC Docket 94-102, require location accuracy of mobile units (e.g., cellular/PCS users) to within about 400 feet for E-911 service by October 1, 2001.

Therefore, a great deal of emphasis has been placed on developing systems that can determine the location of mobile units more accurately. One known method for locating mobile units is time difference of arrival (TDOA) which has been used for many years, at least in such applications as LORAN and GPS systems.

In Code Division Multiple Access (CDMA) systems, the time difference of arrival

measurement is used to determine a hyperbola along which the mobile may be located. This is calculated by using the phase or chip offset of pilot signals received from two different base stations by a mobile terminal. A chip is a time period that corresponds to one bit time of the spreading code used to spectrally spread the pilots transmitted by the base station. An offset in the expected position of the spreading code results from the time delay from the transmitting base station to the mobile terminal and is measured in chips or bit periods of the spread up code. Using this information, the hyperbola is defined along which the mobile station may be located.

#### SUMMARY OF THE INVENTION

A method and an apparatus for enhancing network performance of a wireless network by using generally available geolocation information are provided.

In a first embodiment, geolocation information is utilized to reduce call drop/loss rate. The call drop/loss rate is defined as the number of call failures versus the total number of established calls. In this embodiment, first, the geolocation information is utilized to determine call-dropping zones. Call-dropping zones are geographic clusters having a high rate of call drop/loss. Network enhancement is then achieved by improving the signal quality in these call-dropping zones.

In a second embodiment, geolocation information is utilized to assist in beam steering and shaping of intelligent antennas. The intelligent antennas are systems that use multiple configurable antennas or antenna arrays. In this embodiment, rather than having antennas passively steering and shaping their beams in terms of the rays coming directly from mobiles or reflected by objects, geolocation information is used to steer the beams (i.e., when antennas are adaptive) or select particular beams (i.e., when antennas are fixed-beam). This results in increased capacity and reduced interference.

In a third embodiment, in addition to intelligent antennas, geolocation information is used to deploy downtilt technology. In downtilt technology, antennas are dynamically steered to increase the capacity with no additional cell installation or sectorization. In accordance with the principles of the present invention, first, geolocation information is used to determine zones having most mobiles (i.e., having high call volumes) and then antennas are downtilted towards the zones having high call volumes, thereby reducing interference and increasing clarity.

In a fourth embodiment, geolocation information is used to reduce mobile registration. Generally, registration is the means by which a mobile informs a service provider of its presence in the system and its desire to receive service from that system. Each time the mobile moves from one cell-site to another, it must register or re-register with the new cell-site. This scheme becomes very inefficient, especially in a densely populated urban area, where a mobile may frequently moves between different cell-sites. In accordance with the principles of the present invention, the mobile registration process is improved by utilizing geolocation information. Geolocation information is used to track and predict the likely position of the mobile before the mobile enters a particular cell-site. Thus, re-registration is not required as long as the mobile stays within a service area of a particular master switching center. Thus, registration requirements are reduced.

In a fifth embodiment, geolocation information is used to manage the power level of a mobile. In cellular and personal communication systems, the power levels transmitted by every mobile are under constant control of the serving base station. The serving base station constantly monitors the strength of the signals from the mobile and if the signal strength falls below a pre-determined threshold level, the serving base station sends a power-up signal to the mobile. This scheme becomes very cumbersome in instances where signal strength changes rapidly because of some temporary obstructions, e.g., tunnels, bridges, large trees,

big trucks, etc. Each time the signal strength falls below a pre-determined threshold level due to these obstructions, the serving base station sends a power-up signal to the mobile. Immediately after the obstruction is over, e.g., mobile is out of the tunnel, the power transmitted from the mobile is decreased. Thus, power control often fluctuates widely wherein power transmitted from the mobile is being constantly increased and decreased.

In the present invention, power control is managed better by adding geolocation information as input to the power control. For example, if the serving base station notes that the signal strength to a particular mobile has suffered a substantial loss (i.e., a 40-dB loss) and the geolocation information indicates that the mobile is moving at a 50 miles/hour rate, the transmitting power level is not increased because it is likely that signal strength will be regained after a brief period (e.g., a few milliseconds) as the mobile clears the obstruction. On the other hand, if geolocation information indicates that the mobile is stationary and has suffered a 40-dB loss, the mobile's transmitting power level is increased immediately to maintain a good quality connection.

In a sixth embodiment, geolocation information is used to enhance load-balancing capabilities in a wireless system. Currently, in a wireless system, load balancing is accomplished by monitoring the number of mobiles trying to access a particular base station and, if the base station seems overloaded, by transferring the mobiles having relatively weak signal strength to other base stations. This scheme doesn't account for the geographical location and velocity of the mobiles.

The dynamic load-balancing scheme of the present invention incorporates geolocation information in the decision-making of load balancing. In addition to measuring radio signal strength, the geographical location and the velocity of the moving mobiles are considered in the decision of which mobiles should be transferred. For example, assume both Mobile A and Mobile B are in a handoff zone and Mobile A is moving out of the cell at a fast speed and has

a decreasing signal strength. Mobile B is moving into the cell and has an increasing signal strength. In accordance with the principles of the present invention, Mobile A will be handed off to the base station towards which the mobile is heading. Since Mobile B is moving into the cell, it will not be handed off.

The present invention and its above-described embodiments may be used in wireless networks to increase network performance. In one embodiment, the present invention is a method for enhancing network performance of a wireless network, comprising the steps of (a) determining a current location for a mobile in the wireless network; and (b) using the current location of the mobile to enhance network performance of the wireless network.

#### BRIEF DESCRIPTION OF THE DRAWINGS

Other aspects, features, and advantages of the present invention will become more fully apparent from the following detailed description, the appended claims, and the accompanying drawings in which:

FIG. 1 illustrates the region of possible locations of a mobile determined by signal strength;

FIG. 2 illustrates the region of possible locations of a mobile determined by Time Difference of Arrival (TDOA);

FIG. 3 illustrates the region of possible locations of a mobile determined by Round Trip Delay (RTD);

FIG. 4 illustrates the points of possible locations of a mobile determined by RTD;

FIG. 5 illustrates the point, within the intersection of the regions, that maximizes total distance;

FIG. 6 illustrates the information of TDOA, Time of Arrival (TOA) and Angle of Arrival (AOA) and the estimated locations when 3 base stations are visible;

FIG. 7 depicts the information relevant to the estimation of a mobile's location in an exemplary CDMA system;

FIG. 8 illustrates a generic geolocation system that combines information from a plurality of sources including GPS information and wireless information;

FIG. 9 illustrates a block diagram of a network performance enhancement implementation in accordance with the principles of the present invention;

FIG. 10 illustrates a first network enhancement element termed call drop/loss diagnosis module; and

FIG. 11 illustrates an example where geolocation information is used to assist in the assignment of the fixed-beam antennas;

FIG. 12 illustrates an example where geolocation information may be used to assist adaptive beam antennas to form a customized beam; and

FIG. 13 illustrates an example where geolocation information may be used in dynamic load balancing and forced hand-off.

#### DETAILED DESCRIPTION

Location services are becoming more and more important in cellular systems and are used in applications such as emergency 911 calls and location-based billings. Location services rely on an accurate or an estimated position of a mobile within a wireless network.

There are different ways to determine geolocation information, i.e., the position of a mobile. A mobile transceiver (i.e., a mobile) communicating with one or more base station transceivers has multiple sources of information from which its geographical position may be



estimated. For example, location information can be derived from (i) signal strength (ii) angle of arrival (AOA) of the signal; and (iii) time difference of arrival (TDOA) of the signal.

Due to practical limitations, the information available from a single source is generally noisy and incomplete. For example, signal strength may only be useful for determining the base station sector in which the receiving mobile is located (e.g., pie-shaped region 100 in FIG. 1). Similarly, absolute time may not be known, but only the difference in the time of arrival (TDOA) of signals from two base stations. See FIG. 2, in which region 200 represents the possible locations of a mobile that experiences a particular TDOA value, but with a limited precision. Of course, in some cases, the measurement may yield results that are more accurate. For example, the round trip delay (RTD) of a signal going from the base station to the mobile and then back to the base station may yield a region that can be reasonably approximated by the points on circle 300 of FIG. 3.

It may be advantageous to combine information from different sources. The general process is to find the point or points which are "most representative" of all of the relevant regions. In the simplest case, this may just be the points of intersection 402 of the two curves shown in FIG. 4, in which the region representing measured TDOA is taken to be a hyperbola 406, and the region representing RTD is taken to be a circle 408.

In a more complex situation, there may be multiple points that are within the intersection of regions (e.g., FIG. 5). The chosen point then might be the point whose total distance from the boundaries of the regions is maximized (i.e., the point that is most interior to the intersection of the regions). Or, there may be no points that are simultaneously in all of the regions (e.g., FIG. 6). In that case, the chosen point might be one that minimizes the total distance to all of the regions.

In the general case, the most representative point is calculated by a mathematical optimization. The optimization process may use "penalty functions" that increase for points

farther from the relevant regions. The penalty functions are designed to guide the selection as much as possible toward the most salient points in all of the regions simultaneously. The optimization process may, for example, use different weights for the data from different regions to reflect quality of data, or known usefulness in predicting location.

It may also be advantageous to determine multiple points that are relevant to the estimation of the location. For example, a particular set of measurements might be equally indicative of two different locations (e.g., see the two possible solutions in FIG. 4). In that case, it may be more useful to generate both points as candidate locations, than to choose only one of them or to take some kind of average.

Although the methods described here are generally applied to estimating location from measurements, the same methods can be extended to incorporate other information from which location estimates may be derived. For example, if the mobile is known to be on a certain road, that road can be taken to be one of the relevant regions.

In a CDMA system, visibility means the number of base stations whose pilots are detectable by the mobile terminal. In CDMA system, TDOA, RTD, and AOA are measured and are available, and may be averaged over time to improve the accuracy of location estimates based on these measurements.

FIG. 7 depicts the information relevant to the estimation of a mobile's location in an exemplary CDMA system. This information is categorized as TDOA, TOA, and AOA. In CDMA systems, all this information may be obtained from RTD and PSMM messages which are available at the base station and/or mobile switching center. The contents of the RTD and PSMM are described below:

- RTD - Contains the time stamp, the round trip delay (RTD) measurement and the ID of the primary serving sector, from which TOA (time of arrival) is derived.

PSMM - Contains the time stamp, pilot PN numbers, the pilot phases (or chip off-sets) that imply TDOA of pilots from other base stations versus the base station that contains the primary serving sector, and the pilot strengths from which AOA can be estimated.

It should be noted that PSMM does not always provide TDOA information. For instance, if a PSMM reports pilots that come from a single base station, there is no TDOA information available. Whether TDOA information is available depends on how many base stations are visible at a particular mobile.

FIG. 8 illustrates a generic geolocation system that combines information from a plurality of sources including GPS information and wireless information. In FIG. 8, a mobile 805 is moving in an area that is covered by a wireless system comprising three base stations (BS1, BS2 and BS3), one master switching center (MSC) 801, and one position determination entity (PDE) 803. Each of the base stations has 3 sectors:  $\alpha$ ,  $\beta$ , and  $\gamma$ . The mobile is also equipped with a GPS receiver, which detects the GPS signals from three or more satellites 809. The GPS information is combined with network information for determination of mobile position. This approach offers advantages over conventional means in terms of higher sensitivity, extensive coverage, shorter time to first fix (TTFF), lower power consumption, and robust performance.

Network information that is useful for mobile location is:

- The *TDOA\_hyperbola\_21* and *TDOA\_hyperbola\_31* obtained from the measurement of TDOA of signals from BS1, BS2, and BS3;
- The time of arrival circle *TOA\_circle\_1* obtained from a round trip delay measurement between BS1 and the mobile; and
- The *AOA  $\theta$*  obtained from the ratios of strengths of pilot signals which are generally transmitted from BS1, and recorded in the PSMM message.

FIG. 9 illustrates a block diagram of a network performance enhancement

implementation in accordance with one embodiment of the present invention. As shown in FIG. 9, this implementation **900** comprises: MSC **801**, PDE **803**, and application module **901**. Application module **901** contains multiple network enhancement elements **903-911** that may be operated simultaneously to improve network performance.

MSC **801** gathers general information about the wireless system. In general, the information is gathered from two sources: the mobile and the base stations. In a typical wireless system, the mobile reports back to the serving base station the round trip delay measurements in the downlink. The RTD measurement is used to calculate the distance between the mobile and the serving base station.

Directly coupled to MSC **801** is PDE **803** which computes the location of a mobile. PDE **803** may derive geolocation information from a plurality of sources. Also directly coupled to MSC **801** and PDE **803** is application module **901**. Application module **901** is configured to receive general information from MSC **801** and to receive geolocation information from PDE **803**. Application module **901** is further configured to utilize the general information and the geolocation information to enhance the network performance of the wireless network.

Application module **901** comprises one or more network enhancement elements **903-913**. Each network enhancement element may operate independently, with two or more network enhancement elements operating in parallel. Each network enhancement element utilizes the geolocation information to improve wireless network performance including call drop/loss rate, beam steering, adaptive antenna generation, downtilting and mobile registration..

As illustrated in FIG. 10, in a first network enhancement element, termed call drop/loss diagnosis module **903**, the geographical position of the mobile and its moving

trajectory calculated by PDE 803 are utilized for call drop/loss diagnosis. Call drop/loss is one of the most challenging problems for wireless systems. This problem is getting more and more attention from service providers because of its direct impact on revenue generation. High call drop/loss rates result in reduced customer satisfaction which can lead to reduced revenue.

A call may be dropped due to coverage problems, hand-off failures, access failures, or other reasons. In the present invention, the geolocation information from PDE 803 is used in differentiating geographic or environmental effects from system errors. For instance, a mobile may travel to a temporary obstruction such as under a highway bridge where it encounters very poor coverage and the call is dropped. In another instance, the mobile may travel around a corner in the urban environment where it is suddenly exposed to a new base station and the call is dropped. These examples correspond to different problems. The former case is due to intolerable frame error wherein the signal strength reached below a threshold level and the call is dropped. The latter case is a handoff problem wherein the mobile failed to receive a handoff burst or received the burst too late to direct the mobile for handoff.

In the present invention, the geolocation information is used in pinpointing the problem. For example, call drop/loss diagnosis module 903 may comprise diagnosis software that tracks call-dropping patterns. Initially, the diagnosis software selects a particular group of callers who are chosen as the first group of users who complained about call dropping (step 1003). Then, the diagnosis software tracks the real-time position of those callers (step 1005) by retrieving geolocation information from PDE 803 (step 1007). The diagnosis software may also create a map of critical points where calls are frequently dropped (step 1009). This

critical point map may also integrate the general environment information, e.g., high-rise buildings, underground tunnels, highways, with the actual call-dropping points (step 1011).

In a second embodiment, network enhancement module 905 receives the geographical position of the mobile from PDE 803 to assist in beam steering/selection of intelligent antennas. Intelligent antennas are defined as systems that use multiple antennas or antenna arrays with signal processing capabilities. Intelligent antennas are generally categorized into two types: fixed-beam and adaptive beam. In the case of fixed-beam antennas, geolocation information is used to assign a mobile to one of the available antennas based on the alignment of the beam directivity and the mobile's position. The assignment is made after considering a plurality of factors including availability of antennas, number of mobiles, and the geolocation information.

FIG. 11 illustrates an example where geolocation information is used to assist in the assignment of fixed-beam antennas. BS1 receives signals from mobile 805 along two signal rays along two signal paths. One ray comes directly from mobile 805 and is called line-of-sight (LOS). The second ray is reflected by some object and is indirectly received by the base station. In a wireless environment, the relative strength of these two rays can vary over time due to fading and shadowing. Consequently, the selection of a particular fixed-beam antenna to serve mobile 803 becomes difficult.

In present invention, geolocation information is used to select an appropriate fixed-beam antenna. Geolocation-assisted fixed-beam antennas are more advantageous in TDMA systems and analog systems where the multipath components, such as the reflected ray in FIG. 11, are ignored at the receiver.

In CDMA systems, although existing RAKE receivers combine multipath components to improve the overall signal strength, geolocation information is still useful in selecting a

beam pointing directly to mobile 805. Network enhancement element 905 may further improve the quality of signals, especially signals with marginal or impaired quality, by adjusting the orientation of the sector antennas, and/or tuning the antenna beam width.

Similarly, geolocation information may be used to assist adaptive-beam antennas to form a customized beam pointing towards the mobile to maximize the efficiency and minimize the interference. In this case, as illustrated in FIG. 12, first, geolocation information is used to determine current needs of mobile 805 and to predict future needs of mobile 805. A customized beam is then created which suits the needs of mobile 805.

In a third embodiment, antennas provide “dynamic downtilting.” In this embodiment, a network enhancement element 907 utilizes geolocation information to know the layout of cell sites and zones of heavy traffic (i.e., where a large number of mobiles are located). The antennas are then downtilted in the direction of heavy traffic zones. “Downtilting” techniques and mechanisms are well known in the art. Consequently, the interference is reduced and the overall capacity is increased.

Dynamic downtilt is particularly useful for CDMA systems because adjacent cells are using the same frequency band. By “downtilting” the antenna towards one cell/sector, the interference is reduced and capacity is increased.

In a fourth embodiment, network enhancement element 909 provides a method for improving mobile registration by utilizing geolocation information. Registration is the means by which a mobile informs a service provider of its presence in the system and its desire to receive service from that system. Traditionally, wireless systems utilize timer-based registration wherein a mobile registers every few milliseconds or upon expiration of each pre-determined time period when a mobile is in a roaming status. This registration requirement is very inefficient.

In network enhancement element 909, the mobile registration process is improved by incorporating geolocation information received from PDE 803 in the decision making. Geolocation information from PDE 803 is utilized to determine the current position of mobile 805 as well as to predict the future position of the mobile. MSC 801 utilizes the current position information and the future position information for the delivery or handoff of the calls. Therefore, in accordance with present invention, there is no need to re-register as long as mobile 805 remains within the coverage of MSC 801.

This improved registration technique results in cost savings, especially when mobile 805 is moving in a densely populated urban area where frequent location registration is required. Network enhancement element 907 may also be deployed in a paging network wherein geolocation information may be used to predict a likely position of the mobile. Thereon, the paging call may be sent to a small cluster of base stations and the loading of the paging network may be reduced.

In a fifth embodiment, network enhancement element 911 uses geolocation information to better manage power levels of mobiles. In cellular and personal communication systems, the power levels transmitted by each mobile are under constant control by the serving base station. The serving base station constantly monitors the signal strength of each mobile and if the signal strength falls below a pre-determined threshold level, the serving base station sends a control signal to increase the power from the particular mobile and signal strength is improved. Also, if signal strength exceeds a pre-determined threshold level, the power from the mobile is decreased. This scheme becomes very cumbersome in instances where signal strength changes rapidly because of some temporary obstructions, e.g., tunnels, bridges, large trees, big trucks, etc. Each time the signal strength falls below a pre-determined threshold level due to these obstructions, the serving base station decides to increase the power transmitted from the mobile. Immediately after the obstruction is over,



e.g., mobile is out of the tunnel, the power from the mobile is decreased. Thus, power control takes a wild ride wherein power to the mobile is being constantly increased and decreased.

In the present invention, network enhancement element **911** utilizes geolocation information received from PDE **803** before making its decision to increase or decrease the mobile's power. Network enhancement element **911** receives the geolocation information and creates a lookup table by combining the statistics of the power level versus the system load in conjunction with the location of a mobile. This lookup table may include information on temporary obstructions or other particular geographic zones surrounding each base station.

When the primary base station notices a sudden drop in the signal strength, it communicates this information to network enhancement element **911**. Network enhancement element **911** then evaluates the power level versus system load in conjunction with the location of mobile **805** and makes an intelligent decision based on the statistical information stored in the look-up table. For instance, if the signal in the reversed link suffered a substantial loss (e.g., a 40-dB loss) and the geolocation information indicates that the mobile is moving at 50 miles/hour in a wireless network, there may be no need to adjust the transmitting power level because the deep fading is about 100 ms apart and may last for only several milliseconds. On the other hand, if it is known from the geolocation information that the mobile is stationary and the signal loss is 40 dB, a power-up command may be sent from the base station to the mobile to maintain a good quality connection.

In a sixth embodiment, network enhancement module **913** uses the geolocation information to enhance dynamic load balancing capabilities within a wireless network. In prior art, load balancing is achieved by channel allocation. In prior art, channel allocation may be based on a fixed channel allocation approach or a dynamic channel allocation approach. In the fixed channel allocation approach, each cell is been allocated with a fixed set of channels to achieve spatial efficiency. If all the channels in a cell are occupied, a new

call is blocked and the subscriber does not receive service. In the dynamic channel allocation approach, all the channels are available to the cells in a cluster. In this approach, the channel allocation is based on a "first come, first served" basis.

In accordance with the principles of the present invention, geolocation information is used to gain knowledge on how many mobiles are in a certain area, and how the callers are geographically distributed within cells. Only then are the channels dynamically allocated in accordance with the traffic patterns. This results in spatial efficiency.

In accordance with the sixth embodiment, geolocation information is used in forced handoff procedures. Forced handoff involves transferring to a base station with lower received signal power level a mobile from one base station to another. In prior art, if a particular base station seems overloaded, the mobiles having weak signal strength are transferred out of the particular base station to a new base station. However, this approach is generally inefficient.

For instance, as illustrated in FIG. 13, BS1 and BS2 are base stations each serving a group of mobiles. Mobile A is located in the area covered by both BS1 and BS2. Mobile B, located in the area covered by BS1, then requires service. But BS1 is unable to accept new users due to current load. In the prior art, the mobiles are handed off based on signal strength, because the locations of the mobiles are not known. In the present invention, geolocation information from PDE 803 is used to make hand-off decisions (e.g., in FIG. 13, hand-off caller A to BS2 and then accept caller B at BS1. The geographic distribution of callers with respect to cells is used to redistribute the load among base stations.

The above-described embodiments are only few exemplary embodiments illustrating how geolocation information may be utilized in the network enhancement of wireless networks. These wireless networks include TDMA-based systems and CDMA-based systems. The principles of the present invention are flexible and, in the future as geolocation

information becomes more accessible, this information may be utilized in third-generation wireless networks.

It will be further understood that various changes in the details, materials, and arrangements of the parts which have been described and illustrated in order to explain the nature of this invention may be made by those skilled in the art without departing from the scope of the invention as expressed in the following claims.

CLAIMS

What is claimed is:

1. A method for enhancing network performance of a wireless network, comprising the steps of:

- (a) determining a current location for a mobile in the wireless network; and
- (b) using the current location of the mobile to enhance network performance of the wireless network.

2. The invention of claim 1, wherein step (a) comprises the steps of:

determining current locations of a plurality of mobiles over a pre-determined time period;  
and

wherein step (b) comprises the steps of:

identifying one or more areas of high call-dropping rates based upon the current locations.

3. The invention of claim 1, wherein step (b) comprises the step of selecting a suitable fixed antenna for transmitting or receiving to or from the mobile from a plurality of available fixed antennas based on the current location of the mobile.

4. The invention of claim 1, wherein step (b) comprises the step of adaptively generating a customized beam for the mobile based on the current location of the mobile.

5. The invention of claim 1, wherein step (a) comprises the steps of:

determining current locations of a plurality of mobiles over a pre-determined time period;  
and wherein step (b) comprises the step of:

modifying the downtilt angle of one or more base station antennas based on the current locations of the mobiles.

6. The invention of claim 5, further comprising the steps of:

(i) identifying zones of heavy traffic based upon the current locations of the mobile; and

(ii) modifying the downtilt angle of one or more base station antennas based on the identity of heavy traffic zones.

7. The invention of claim 1, wherein step (a) comprises the steps of:

determining current locations of a plurality of mobiles over a pre-determined time period; and wherein step (b) comprises the steps of:

requiring re-registration only if the mobile will be moving out of the coverage of the serving master switching center.

8. The invention of claim 7, further comprising the steps of:

(i) predicting a future location of the mobile based upon the current location and previous location of the mobile; and

(ii) determining re-registration requirements based on the current and previous locations of the mobile.

9. The invention of claim 1, wherein step (b) comprises the steps of:

(i) estimating a future location of the mobile based upon the current location and previous location of the mobile; and

(ii) deciding whether to transmit a power-level up signal based on the estimated future location of the mobile.

10. The invention of claim 9, further comprising the steps of:

(i) determining if signal strength of the mobile has fallen below a predetermined level;

(ii) estimating a future location of the mobile based upon the current location and previous location of the mobile; and

(iii) deciding whether to transmit a power-level up signal based on the signal strength and estimated future location of the mobile.

11. The invention of claim 1, wherein step (b) comprises the steps of:

(i) estimating a future location of the mobile based upon the current location and previous location of the mobile; and

(ii) deciding whether to transmit a power-level down signal based on the estimated future location of the mobile.

12. The invention of claim 11, further comprising the steps of:

(i) determining if signal strength of the mobile has exceeded a predetermined level;

(ii) estimating a future location of the mobile based upon the current location and previous location of the mobile; and

(iii) deciding whether to transmit a power-level down signal based on the signal strength and estimated future location of the mobile.

13. The invention of claim 1, wherein step (a) comprises the steps of:

(i) determining current locations of a plurality of mobiles over a pre-determined time period; and wherein step (b) comprises the step of selecting mobiles for forced hand-off based upon the current locations of the mobiles.

14. The invention of claim 1, wherein step (a) comprises the steps of:

(i) determining future locations of a plurality of mobiles over a pre-determined time period; and wherein step (b) comprises the step of selecting mobiles for forced hand-off based upon the future locations of the mobiles.

1/7

FIG. 1

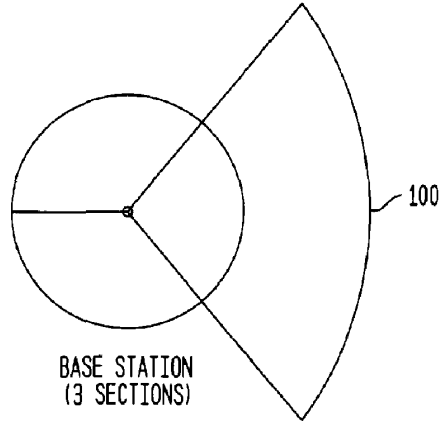


FIG. 2

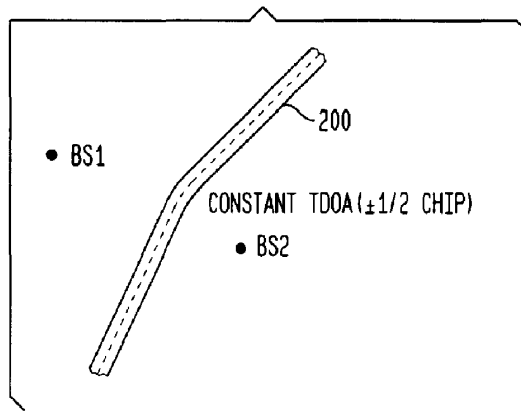
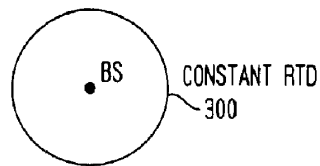
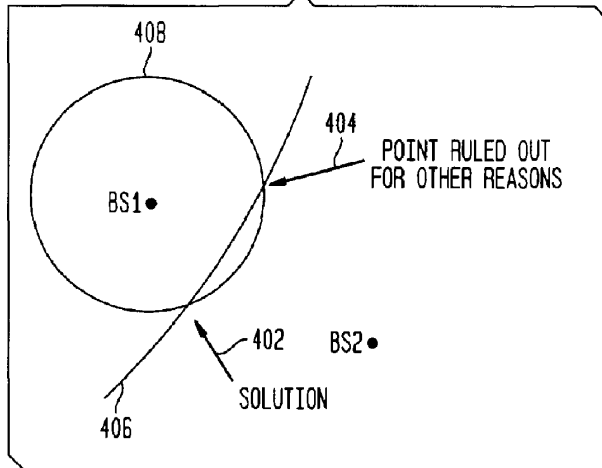


FIG. 3

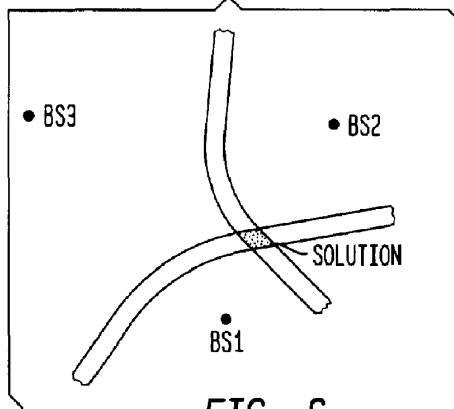




217  
**FIG. 4**



**FIG. 5**



**FIG. 6**

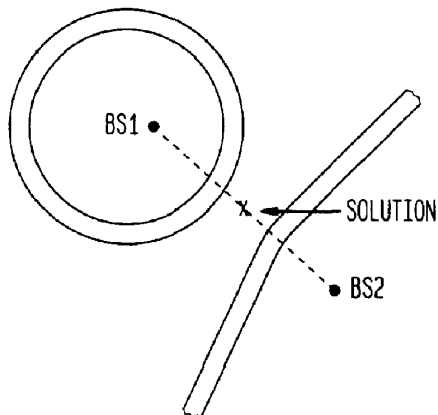
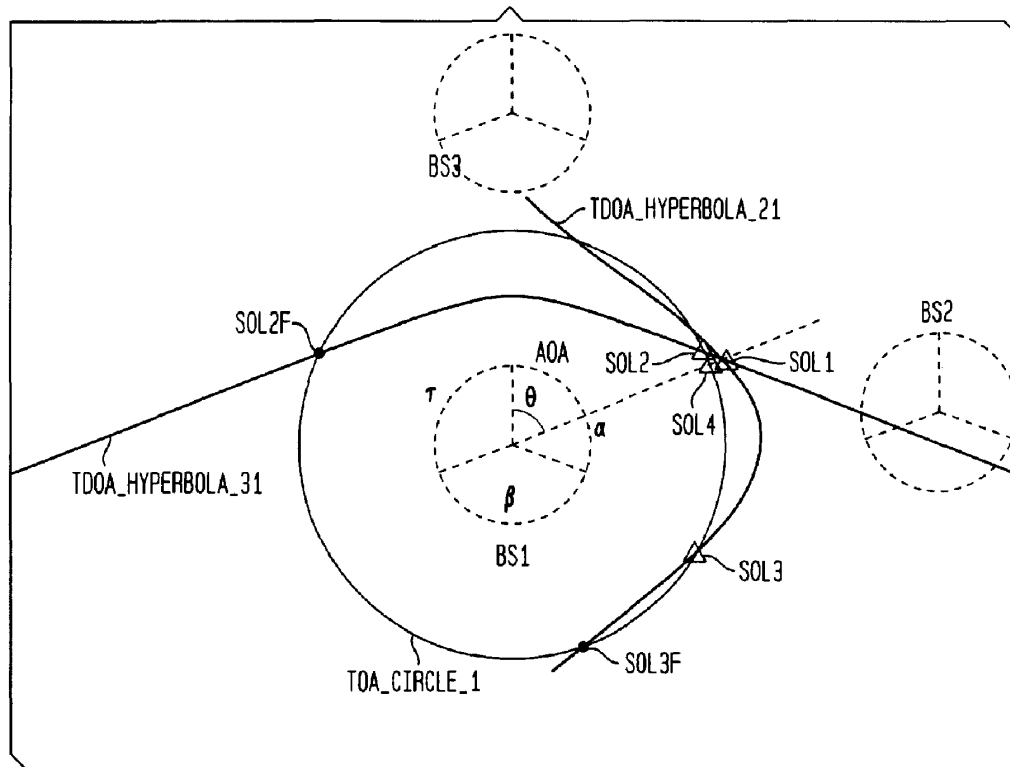
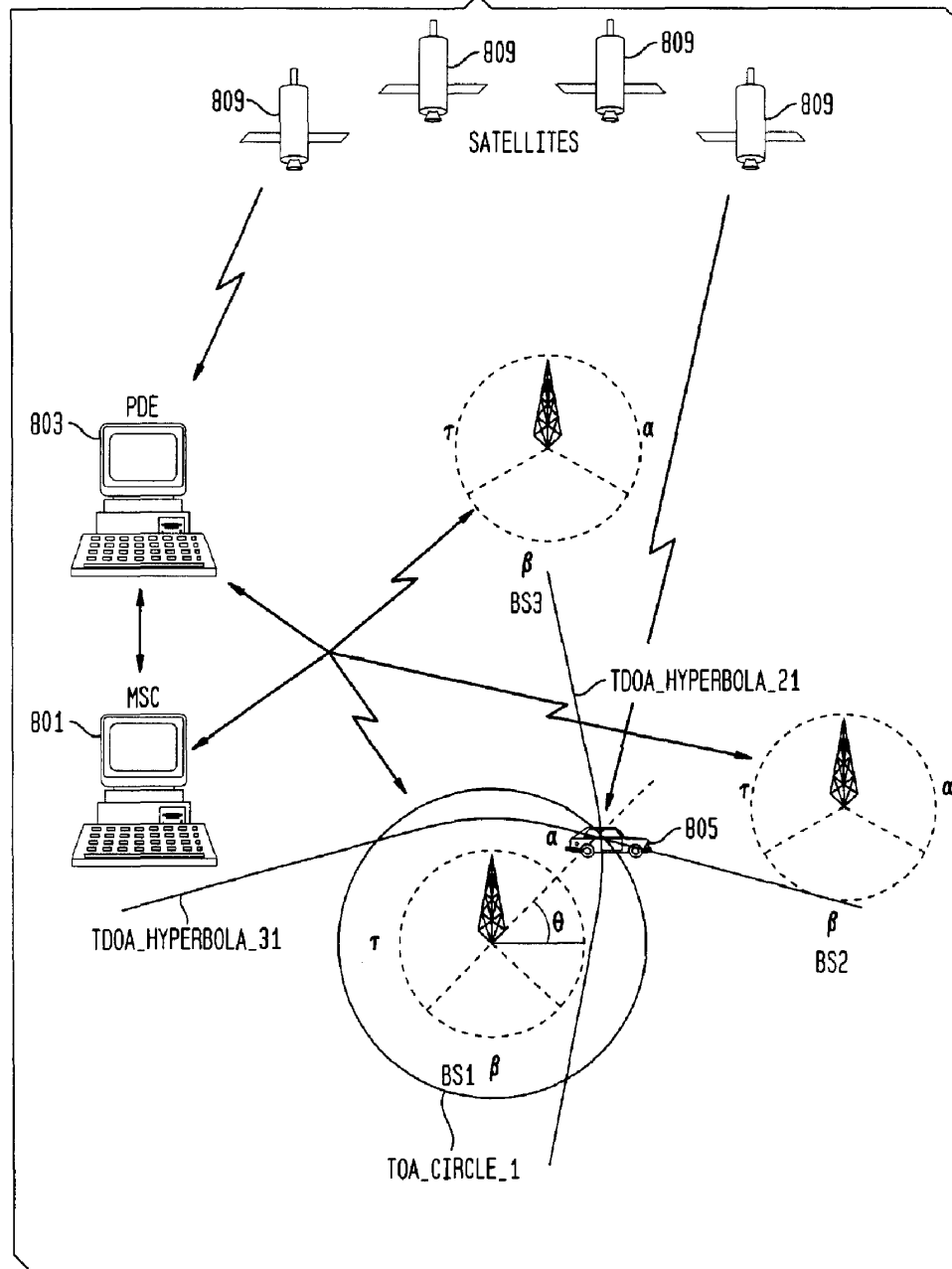


FIG. 7



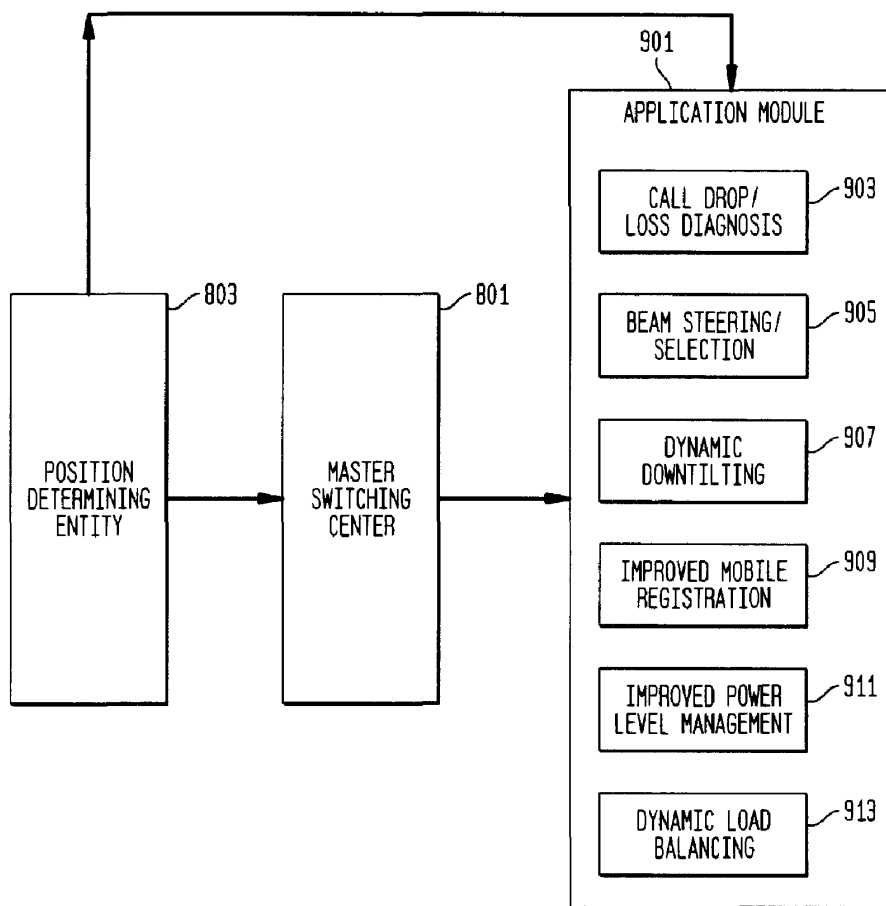
4/7

FIG. 8



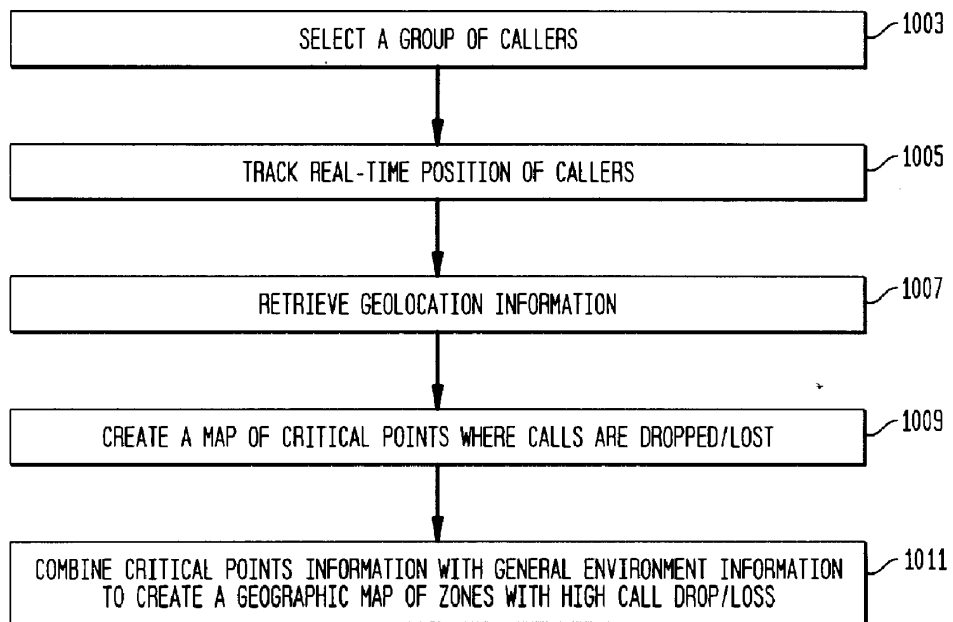
5/7

FIG. 9



6/7

FIG. 10



7/7

FIG. 11

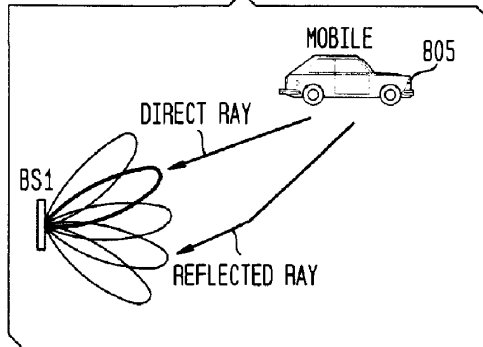


FIG. 12

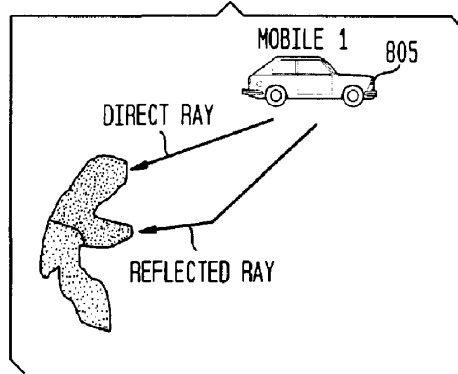
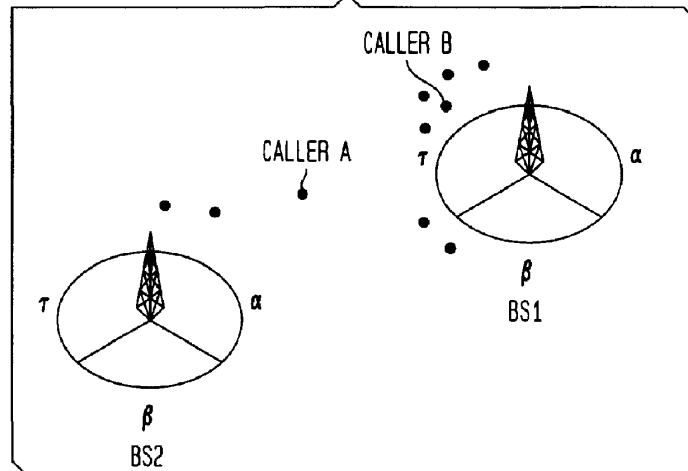


FIG. 13





(12) **EUROPEAN PATENT APPLICATION**

(43) Date of publication:  
**03.04.1996 Bulletin 1996/14**

(51) Int. Cl.<sup>6</sup>: **H04Q 7/38**, G01S 5/00,  
**H04Q 7/24**

(21) Application number: **95112773.7**

(22) Date of filing: **14.08.1995**

(84) Designated Contracting States:  
**AT BE CH DE DK ES FR GB GR IE IT LI LU MC NL**  
**PT SE**

(72) Inventor: **Leblanc, Frederick Warren**  
**Arvada, Colorado 80005 (US)**

(30) Priority: **28.09.1994 US 314482**

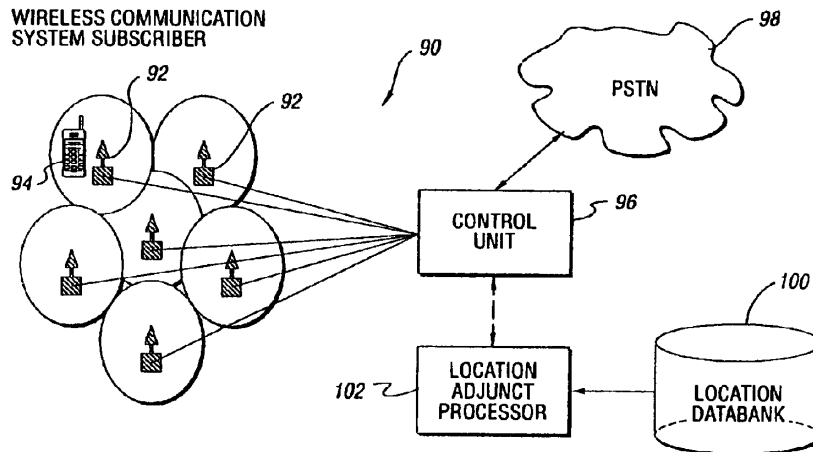
(74) Representative: **Grättinger & Partner**  
**Postfach 16 55**  
**D-82306 Starnberg (DE)**

(71) Applicant: **US WEST Technologies, Inc.**  
**Boulder, Colorado 80303 (US)**

(54) **System and method for updating a location databank**

(57) A system and method for updating a location databank of a personal location system which is directed for use in a wireless communication system. A plurality of update centers are provided at known fixed locations within a base station coverage area. Each of the update centers includes means for transmitting its own precalibrated location information to a location databank along with real-time RF measurements for the base station. Each of the base stations is provided in electrical communication with a location adjunct processor which, in

turn, is provided in electrical communication with the location databank and the public switched telephone network. Processing logic is operative to obtain the desired RF measurement at GeoPads which are provided in electrical communication with each update center. Processing logic is further operative to initiate a call to the LAP in order to transmit the measurements to the location databank along with the decoded location information so as to provide periodic updating.



*Fig. 5*

EP 0 705 046 A2

**Description****Technical Field**

5 The present invention relates generally to positioning systems. More particularly, the invention relates to a method and system for updating a location databank used to determine the position of a mobile unit in a wireless communication system.

**Background Art**

10 Most metropolitan areas are now equipped with one or more forms of wireless communication networks which provide mobile telephone and other related services to customers across a broad frequency spectrum. Consider, for example, what has come to be known as "cellular" telephone services or Personal Communication Services "PCS", i.e., radio transmissions in the frequency band between approximately 800 MHz and 2.2 GHz.

15 As shown in Figure 1, prior art cellular telephone systems 10 include a Mobile Telephone Switching Center (MTSC) 12 and a plurality of base stations such as cell site transceivers 14a-14c. The cell site transceivers transmit radio signals to and receive radio signals from one or more mobile units 16 that move about a cellular service area 20. A mobile unit, as the term is used herein, refers to a wireless voice telephone or data receiver that can be permanently installed at a fixed location or within a vehicle or that can be portable. Each cell site transceiver 14 is able to broadcast and receive the radio signals within a geographic area 18 called the cell site coverage area. Together, the areas 18 comprise the entire cellular service area 20. Typically, a cellular service area comprises a metropolitan area or larger region.

20 When a telephone call to a called mobile unit 16 originates from either another mobile unit or a land-based telephone via a Public Switched Telephone Network (PSTN) 22, a caller must first access the cellular telephone system 10. This task is accomplished by dialing the mobile unit's unique identification number (i.e., its phone number). The MTSC 12 receives the call request and instructs the control unit, i.e., the central call processor 24 to begin call processing. The central call processor 24 transmits a signal over a dedicated line 26 (such as a telephone line or microwave link, etc.) to each of the cell site transceivers 14a-14c causing the cell site transceivers to transmit a page signal that the mobile unit 16 receives. The page signal alerts a particular mobile unit 16 that it is being called by including as part of the page signal the paged mobile unit's identification or phone number.

30 Each cell site transceiver 14 transmits the page signal on one or more dedicated forward control channels that carry all pages, as well as control signals, channel assignments, and other overhead messages to each mobile unit. The forward control channel is distinct from the voice channel that actually carries voice communications between a mobile and another mobile unit or a land-based telephone. Each cell site transceiver may have more than one forward control channel upon which pages can be carried.

35 When a mobile unit is not engaged in a telephone call, it operates in an idle state. In the idle state, the mobile unit will tune to the strongest available forward control channel and monitor the channel for a page signal or other messages directed to it. Upon determining that a page signal is being transmitted, the mobile unit 16 again scans all forward control channels so as to select the cell site transceiver 14a-14c transmitting the strongest signal. The mobile unit then transmits an acknowledgement signal to the cell site transceiver over a reverse control channel associated with the strongest forward control channel. This acknowledgement signal serves to indicate to the MTSC 12 which of the forward control channels (associated with the several cell site transceivers 14a-14c) to use for further call processing communications with mobile unit 16. This further communication typically includes a message sent to the mobile unit instructing it to tune to a particular voice channel for completion of call processing and for connection with the calling party.

45 The details of how the cell site transceivers transmit the signals on the forward and reverse control channels are typically governed by standard protocols such as the EIA/TIA-553 specification and the air interface standards for Narrowband Analog Mobile Phone Services (NAMPS) IS-88 and IS-95 air interface standards for digital communications, all of which are well known to those of ordinary skill in the wireless telephone communications art and therefore will not be discussed.

50 While cellular networks have been found to be of great value to mobile users whose travels span many miles, they have also been found to be prohibitively expensive to implement for small scale applications wherein system subscribers only desire wireless telephone services in limited geographic areas, such as, for example, within office buildings or in campus environments.

55 The Personal Communications Network (PCN) is a relatively new concept in mobile communications developed specifically to serve the aforementioned applications. Similar to cellular telephony goals, a Personal Communications Network goal is to have a wireless communication system which relates telephone numbers to persons rather than fixed locations. Unlike cellular telephones, however, the PCN telephones are directed to small geographic areas thus defining "micro-cellular" areas designed to operate in similar fashion to large scale cellular telephone networks. PCN technologies are also similar to residential cordless telephones in that they utilize base stations and wireless handsets. Unlike the former, however, PCN technology utilizes advanced digital communications architecture, such as, for example, PACS,



formerly called WACS, (Bellcore), DECT (European), CDMA (Omnipoint), PHS-PHP (Japan), IS-54 (TDMA), IS-95 (CDMA), PCS-1900 (GSM), and B-CDMA (Oki), and features which may be implemented either as private networks or regulated services. When offered by communications carriers as services, this PCN capability is generally referred to as Personal Communications Services (PCS), and may be situated in a wide variety of environments, including, for  
 5 example, outdoor urban, suburban, rural, indoor single-level and indoor multi-level areas.

As shown in Figure 2, prior art PCS systems 28 include one or more control units 30 which, in accordance with the American National Standards Institute (ANSI) T1P1 working document for stage 2 service description, as known to those skilled in the art, are termed Radio Port Controllers (RPCs), Radio Access System Controllers (RASCs), access managers, etc. These control units 30 operate in similar fashion to the MTSC 12 of the cellular telephone network and,  
 10 therefore, are provided in electrical communication with the Public Switched Telephone Network 22. A plurality of base stations or Radio Ports (RPs) 32 are also provided which transmit radio signals to and receive radio signals from one or more subscriber wireless telephones 16, termed mobile units or Radio Personal Terminals (RPTs) that move about a PCS service area 34. Each Radio Port 32, like cell site transceivers 14, is able to broadcast and receive radio signals within a geographic area 36 called the Radio Port coverage area. Together, the areas 36 comprise the entire PCS service  
 15 area 34.

A generalized reference architecture for the PCS system of Figure 2 is shown in further detail in Figures 3a-3b. The reference architecture includes reference elements which support radio access, wireline access, switching and control, mobility management, and Operations, Administration, Maintenance and Purchasing (OAM&P). As shown in the schematic, the PCS system includes a PCS Switching Center (PSC) 38 which supports access independent call/service control and connection control (switching) functions and is responsible for interconnection of access and network systems to support end-to-end services. The PCS switching center 38 represents a collection of one or more network elements. The system further includes a Radio Access System Controller (RASC) 40 which supports the wireless mobility management and wireless access call control functions. It serves one or more subtending radio port controllers 42 and may be associated with one or more PCS switching centers 38. As known to those skilled in the art, Radio Port Controllers  
 20 42 provide an interface between one or more subtending Radio Port Intermediaries (RPIs), a PCS switching center such as PSC 38, and RASC, air interface independent radio frequency transmission and reception functions.

The system further includes a Radio Port Intermediary (RPI) 44 which provides an interface between one or more subtending Radio Ports 46 and the Radio Port Controller 42, and supports air interface dependent radio frequency transmission and reception functions. Radio Port 46 supports the transmission of signals over the air interface and is provided in communication with Radio Personal Terminal (RPT) 48. This is a light-weight, pocket-size portable radio terminal providing the capability for the user to be either stationary or in motion while accessing and using telecommunication services.  
 30

The system further includes variations of RPTs which are in fixed locations, termed Radio Termination (Type 1) 50 and Radio Termination (Type 2) 52, which interface Terminal Equipment (Type 1) 54 and Terminal Equipment (Type 2) 56 to the Radio Access Interface.  
 35

The system of Figure 3 further includes a Terminal Mobility Controller (TMC) 58 which provides the control logic for terminal authentication, location management, alerting, and routing to RPT/RTs. There is also provided a Terminal Mobility Data-store (TMD) 60 which is operative to maintain data associated with terminals.

Still further, the system includes a Personal Mobility Controller (PMC) which provides the control logic for user authentication, service request validation, location management, alerting, user access to service profile, privacy, access registration, and call management. PMC 62 is provided in communication with a Personal Mobility Data-store (PMD) which maintains data associated with users.  
 40

Finally, the system includes Operations, Administration, Maintenance, and Provisioning, (OAM & P) systems 66 which monitor, test, administer, and manage traffic and billing information for personal communications services and systems. PCS 38 is also provided in communication with Auxiliary Services 68, Interworking Functions (IWF) 70 and External Networks 72. In accordance with the above-referenced working document for Stage 2 service description, Auxiliary Services 68 are defined as a variety of services such as voice mail, paging, etc. which may not be provided by the PCS 38. IWF 70 are further defined as mechanisms which mask the differences in physical, link and network technologies into consistent network and user services. Still further, External Networks 72 are defined as other voice, digital data, packet data, and broadband data networks.  
 45  
 50

Figure 4 provides a unified functional model of the detailed system of Figures 3a-3b. This functional model is derived from the PCS reference architecture in Figure 3 by aggregating the terminal entities (RT and RPT) into a single functional grouping RTF, and aggregating RP, RPI, and RPC into another single functional grouping RCF in accordance with the Stage 2 service descriptions for PCS. The model includes Call Control Function (CCF) 74, Service Switching Function (SSF) 76, Service Control Function (SCF) 78, Service Data Function (SDF) 80, Service Resource Function (SRF) 82, Radio Access Control Function (RACF) 84, Radio Control Function (RCF) 86, and Radio Termination Function (RTF) 88. The functions of the terminal elements are more fully described in the Stage 2 service description for PCS.  
 55

Wireless communication services such as the above cellular and PCS systems, have been quickly embraced by those people whose business requires them to travel frequently and to be in constant communication with their clients

and associates. The increased use of wireless communication services, however, have caused headaches for emergency operators and other position dependent service providers who require precise location data. As known to those skilled in the art, under current wireless technology, position data is strictly limited to relatively large coverage areas and sectors thereof as defined by the RF characteristics, i.e. footprints, of the associated base station. As explained below, these coverage areas are generally unsuitable for most commercial and consumer applications.

In the late 1960's, federal legislation was enacted which established the 9-1-1 telephone number as a national emergency resource. In land-based systems, Enhanced 9-1-1 (E 9-1-1) wireline technology provides the caller's Automatic Location Identification (ALI) with reasonable accuracy, cost and reliability, to a Public Safety Answering Point (PSAP) via a defacto standard. ALI is generally accomplished by receiving the ANI, or Automatic Number Identification, during call setup to the PSAP. A database query, given ANI, provides ALI to the emergency call taker display terminal as both parties establish the voice channel.

Currently wireless technology, however, does not provide ALI. As a result, an ever-increasing percentage of emergency telephone calls can be tracked no further than the originating base station. As readily seen, the heart of the problem for providing E9-1-1 ALI services for wireless communication customers lies in accurately and reliably determining the mobile unit, i.e., handset location, under any circumstance, at low cost.

Against this background, there have been previous attempts to provide methods and systems which generally identify the positions of wireless communication system users in cell site coverage areas and sectors thereof. See, for example, U.S. Patent No. 4,876,738 issued to Selby and assigned to U.S. Phillips Corporation. Selby discloses a registration procedure in which the base station monitors the location of the mobile unit by cell site. The effect is to allow enlargement of the registration area if the mobile unit consistently roams between two cells.

See also, U.S. Patent No. 5,179,721 issued to Comroe et al and assigned to Motorola, Inc. Comroe discloses a method for inter-operation of a cellular communication system and trunking communication system by transmitting an access number for each system such that the mobile unit may be used as a cellular telephone and a trunking communication device.

Still further, see U.S. Patent No. 5,097,499 issued to Consentino and assigned to AT&T Bell Laboratories. Consentino teaches a method for preventing an overload in a reverse channel by delaying the time of the generation of timing stamps on markers.

These methods and systems, however, have proven unsuitable for commercial and consumer applications where users may, at any given time, travel through very small portions of numerous cell site coverage areas and sectors. Under current wireless technology, and as described in the prior art referenced above, presently available positioning methods and systems are limited to a determination of whether the user is within one or more predetermined cell site coverage areas or sectors. These prior art systems are incapable of providing further detail, i.e. exactly where in the cell site coverage area the user is located.

Prior art attempts to design higher accuracy positioning systems which utilize commercial broadcast transmissions, for example, have also met with limited success. See, for example, U.S. Patent Nos. 4,054,880 (Dalabakis et al) and 3,889,264 (Fletcher) which disclose what are known as "delta-position" systems. These prior art patents describe systems using three spectrally spaced-apart radio signals, each of which is an independent AM radio signal. The systems typically have a vehicle carried mobile receiver, with a separate tuner for each station, and a second receiver at a fixed, known position. As disclosed, these systems count "zero crossing counts", each of which indicates that the user has moved a certain distance from his or her previous location. In operation, if it is desired to determine the current position of the user, a starting position must first be specified. A fixed position receiver detects frequency drift of the transmitters, which is used to adjust and coordinate zero crossing counts made by the mobile receivers.

These systems are termed "delta-position" systems because they determine only the distance and direction traveled by a mobile user from any particular starting point. Neither Dalabakis et al nor Fletcher actually determines the position of the mobile user.

See also, U.S. Patent No. 5,173,710 to Kelley et al which discloses the use of a fixed position receiver which is adapted to determine frequency drift along with the relative phases of various unsynchronized FM broadcast signals originating from known fixed locations. As disclosed by Kelley, each of the fixed transmitters transmits a beacon signal having a phase that is unsynchronized with the phases of the beacon signals of the other transmitters. These signals are 19 Khz analog pilot tones generated by commercial broadcast stereo FM stations. The fixed receiver receives the beacon signals, determines the relative phases of the beacon signals, and broadcasts data representing these relative phases for receipt by the mobile receiver which is at an unknown location. Each mobile receiver includes phase measurement circuitry that detects the phases of the beacon signals at the mobile receiver's current position on multiple distinct carrier frequencies such that the current position of the mobile unit may be determined when used in conjunction with the fixed receiver broadcast data.

See also, U.S. Patent Nos. 5,055,851; 4,891,650; and 5,218,367, all issued to E. Sheffer and assigned to Trackmobile, Inc. Like the '650 patent, the '851 patent utilizes measurements of the mobile unit's signal strength which is detected by some number of neighboring base stations in order to calculate location. In operation, each base station transmits a special packet of data which includes this information for receipt by the MTSC. Another packet of information, the actual

vehicle alarm distress call (this is not the same as a 9-1-1 call), is also sent to the MTSC. The MTSC sends these two information packets to a Trackmobile alarm center personal computer. The computer matches both packets using a simple algorithm in order to find the vehicle's distance from the base station cell center point. As disclosed, this is done preferably with four neighboring base station cell site measurements along with arcuation or line intersection techniques.  
 5 The results are displayed on a computer screen map. A 9-1-1 call may then be initiated by a Trackmobile attendant, based on a verbal request from the originating mobile user.

The Trackmobile '367 patent operates in much the same way as the '851 and '650 patents although it uses a modified handset including a modem, to send signal strength measurements received at the mobile unit, through the cellular network to the Trackmobile alarm center. Only the downlink signal strengths, received at the mobile unit, are used to  
 10 estimate location. The location is determined from the same algorithm as in the '851 patent, but includes a refinement -- antenna sector ID -- if known. As disclosed, the sector ID information reduces error by effectively slicing the cell circle into one of three pie-shaped sections. In the case of low power PCS installations, it is likely that omnidirectional antennas would be used, thus precluding the use of this sector refinement.

None of the systems referenced above, as well as general time difference of arrival location systems such as LORAN,  
 15 NAVSTAR, and GPS, as used for example in U.S. Patent No. 4,833,480, issued to Palmer et al, have proven suitable for commercial applications since, by design, they require specially adapted receivers to receive and process the pilot tones, GPS signals, etc. at the mobile unit. This sophisticated end equipment, of course, significantly adds to the cost of the corresponding mobile unit. In the case of hand portable units, this additional equipment further results in a handset which is extremely bulky and difficult to handle. As a result, these systems have proven unsuitable for both large scale  
 20 commercial applications, as well as ordinary consumer use.

When applied to wireless communications of interest to the present invention, i.e. communications in the frequency band from 800 MHz to 2.5 GHz, these prior art systems are further considered unsuitable for commercial applications in view of their anticipated use of excessive frequency spectrum. More specifically, it is anticipated that for proper operation, these systems would necessarily require transmission of signals on separate channels which would utilize an  
 25 unacceptable amount of additional spectrum.

The prior art systems also fail to account for changes in environmental conditions. For GPS receivers, it is known to those skilled in the art that the location calculation will not work unless there is a clear view of at least 3-4 satellites. In dense urban areas, especially at the street level, this condition could easily prevail. Thus, no location estimate would be available if less than three satellite signals can be received.

In many office buildings, the metal content of the windows is also sufficient to preclude effective satellite reception. To this end, if all wireless antennas were isotropic and were located in flat and open terrain, estimating the location of a handset using the prior art strength technology might be sufficient. Unfortunately, the known disadvantage of the PCS world, and to a reasonable extent, cellular, is that they do not operate in flat and open terrains. None of the prior art patents work in areas where there are obstructions to the radio signal's path like buildings, trees, hills, and automobiles.  
 30 Seasons are also known to have a dramatic affect on propagation where radio waves are significantly attenuated by tree leaves in the summer, but less so in the winter. Thus, actual RF field data gathered in one season may not be accurate in another season.

As readily seen, precisely predicting location based on RF propagation loss has generally been an intractable problem, due to the complexity of factors, as well as the data collection difficulties in constructing the necessary databases needed to supply the actual field data. Thus, the principles relied upon by the above-referenced prior arts patents, free space loss, rarely exists, as obstructions and interference increases daily, even in the most optimal RF environments.

Consequently, a need has developed to provide a positioning system and method which may be practically and economically implemented for use in wireless communication systems and, in particular, in the microwave band from  
 40 800 MHz to 2.5 GHz.

Still further, a need has developed to provide such a positioning system which may be dynamically updated and used by service providers to provide location information for use in emergency situations such as locating an E9-1-1 caller, enforcing restraining orders and house arrests, confirming the intended location of a user at predetermined times and the like. It is further desirable that such a system and method be compatible with existing wireless telephone technology and should not degrade the operation of an existing system. Finally, such a system should neither require the  
 50 allocation of more radio frequencies than are currently allocated to wireless telephone systems, nor require a substantial portion of existing wireless frequencies.

#### **Disclosure Of The Invention**

55 It is an object of the present invention to provide a system and method for updating a location databank used in a wireless communication system to generate scaled contour shapes having minimum and maximum boundaries, the intersection of which provides a bounding polygon area corresponding to the location of a mobile unit.

In carrying these and other objects, features and advantages of the present invention, a system and method for updating the location databank is provided and is directed specifically for use in cooperation with a location system and

method in a wireless communication system, sometimes also called a land mobile telecommunications system, including a base station in electrical communication with at least one mobile unit within a corresponding coverage area and a location database operative to store real-time RF measurements for the base station. The system includes a plurality of update centers at known fixed locations within the base station coverage area. Each of the update centers includes means for transmitting its own pre-calibrated location information to the location databank along with the real-time RF measurements for the base station in cooperation with the mobile unit.

In a preferred embodiment, the means for transmitting the pre-calibrated location information to the location database along with the real-time RF measurements for the base station includes a plurality of electronically-readable stations termed "Geopads" each of which is positioned at a corresponding update center and encoded with pre-calibrated location information for that center. An electronic reading device is provided in electrical communication with the mobile unit for decoding the encoded location information at each of the Geopads. A Location Adjunct Processor (LAP) such as an Intelligent Peripheral (IP) or similar logic contained in a service logic program of a Service Control Point (SCP), or the like, is further provided in electrical communication with the base station and the location databank. Finally, processing logic in electrical communication with the mobile unit is operative to obtain the RF measurements at each of the Geopads and initiate a call to the LAP to transmit the measurements to the location databank along with the decoded location information.

In an alternative embodiment, a holding database is further provided in electrical communication with the LAP and the location databank. The holding database is operative to temporarily store the RF measurements and location information so as to periodically update the location databank.

In yet another alternative embodiment, a mobile unit which is modified to communicate with a Geopad may also be used to communicate with a service provider Geopad system. For example, precalibrated location information may be displayed at the update center of a Geopad which may be communicated to the service provider by a Geopad user. In operation, it is anticipated that a Geopad user would dial a designated telephone number displayed at a given Geopad, log-on to the Geopad system and enter the displayed latitude/longitude information. At the same time, the user's mobile unit would contain control logic which enables the unit to transmit its downlink or forward channel real-time RF measurements so as to dynamically update the location databank or holding database.

During the time of this Geopad telephone call, the LAP would also instruct neighboring base stations or radio ports to tune to the transmit frequency of the Geopad user's mobile unit, and perform uplink or reverse channel RF measurements.

In a further alternative embodiment, telephone service providers may also be provided a special directory number as a convenient means to update the Geopad system with changes in network elements which may affect system calibrations. For example, information regarding changes and antenna type, placement, etc. may be provided by calling a designated number or, in the alternative, through a modem or internet connection.

In further keeping with the invention, there is disclosed a method for periodically updating the location database which is used for location processing in a wireless communication system which includes a base station in electrical communication with at least one mobile unit within a corresponding coverage area. The method includes the provision of a plurality of update centers at known fixed locations within the base station coverage area, each of which includes an electronically-readable Geopad encoded with pre-calibrated location information for that center. The method further includes providing an electronic reading device in electrical communication with the mobile unit and decoding the encoded location information at the Geopads through the use of the electronic reading device. Still further, the method includes providing processing logic in electrical communication with the mobile unit, providing a control unit in electrical communication with the base station and further providing a Location Adjunct Processor (LAP) such as an Intelligent Peripheral, or the like, in electrical communication with the control unit. By making real-time RF measurements at one of the Geopads and initiating a call to the LAP in cooperation with the processing logic, measurements may be transmitted along with the decoded location information so as to update the location database. In an alternative embodiment, a holding database may also be provided in electrical communication with the LAP and the location database. In such case, the processing logic will transmit the RF measurements along with the decoded location information to the holding database for temporary storage and later periodic updating of the location database.

**Brief Description Of The Drawings**

The foregoing aspects and many of the attendant advantages of this invention will become more readily appreciated as the same becomes better understood by reference to the following best modes for carrying out the invention, when taken in conjunction with the accompanying drawings wherein like reference numerals correspond to like components and wherein:

FIGURE 1 is a schematic diagram of a prior art cellular telephone system;

FIGURE 2 is a generalized schematic diagram of a prior art Personal Communications System (PCS);

## EP 0 705 046 A2

FIGURES 3a-3b are detailed schematic diagrams of the reference architecture of the PCS system of Figure 2;

FIGURE 4 is a unified functional model of the system of Figures 2 and 3;

5 FIGURE 5 is a schematic diagram of a first embodiment of a positioning system directed for use with the present invention;

FIGURE 6 is a schematic diagram of a second embodiment of a positioning system directed for use with the present invention in a modified Advanced Intelligent Network (AIN);

10 FIGURE 7 is a schematic diagram of a third embodiment of a positioning system directed for use with the present invention;

FIGURE 8 is a representative curve fit graph obtained from the generic curve fit database used in accordance with the present invention;

FIGURE 9 is a schematic of typical data obtained when utilizing the Bollinger band database in accordance with the present invention;

20 FIGURE 10 is a schematic diagram of representative bounding polygons obtained by using a run-time database in accordance with the present invention;

FIGURE 11 is a schematic diagram of representative arc-segments drawn around a Radio Port;

25 FIGURE 12 is a schematic diagram of a first sample curve-fit data plot before and after a manual search;

FIGURE 13 is a schematic diagram of a second sample curve-fit data plot before and after a manual search;

FIGURE 14 is a schematic diagram of a third sample curve-fit data plot before and after a manual search;

30 FIGURE 15 is a schematic diagram of a fourth sample curve-fit data plot before and after a manual search;

FIGURE 16 is a schematic diagram of a best fit confidence interval with maximum and minimum bands;

35 FIGURE 17 is a schematic diagram of a representative Bollinger band;

FIGURE 18 is a schematic diagram of a location band;

40 FIGURES 19-20 provide representative schematics of  $RSSI_{downlink}$  and  $WER_{uplink}$ ;

FIGURE 21 is a block diagram of the method steps used in accordance with the present invention to populate the location databank;

45 FIGURE 22 is a schematic diagram of an example bounding polygon defined by two base stations;

FIGURE 23 is a schematic diagram of the bounding polygon of Figure 22 as projected on an ortho-photograph which may be stored digitally;

FIGURE 24 is a schematic diagram of a sample bounding polygon defined by a single base station;

50 FIGURE 25 is a schematic diagram of the system of the present invention for updating a location databank; and

FIGURE 26 is a generalized block diagram of the updating method of the present invention.

### 55 **Best Modes for Carrying Out the Invention**

With reference to Figures 5-7 of the drawings, there is provided schematic diagrams of several positioning systems directed for use with the present invention, i.e., they may be updated in accordance with its teachings.

## EP 0 705 046 A2

A first positioning system is shown in Figure 5 and designated generally by reference numeral 90. System 90 includes at least one base station 92 such as a Radio Port (RP) which is operative to receive calls from one or more mobile units 94 such as Radio Personal Terminals (RPTs) over air interface channels. System 90 further includes a control unit 96 such as a Radio Port Controller (RPC) or Radio Access System Controller (RASC), which is provided in electrical communication with the Public Switched Telephone Network (PSTN) 98. The functions of control unit 96 may be implemented in a Mobile Telephone Switching Center (MTSC) when used in a cellular telephone network or they may be implemented in an RPC or RASC when used in a PCS system or the like. A location databank 100 is also provided which is operative to store real-time RF measurements for base stations 42, including their link budgets. It is these RF measurements that are sought to be updated in accordance with the present invention.

As explained in further detail herein, the updatable RF measurements may include, for example, Relative Signal Strength Indication uplink ( $RSSI_{up}$ ), Relative Signal Strength Indication downlink ( $RSSI_{down}$ ), Word Error Rate uplink ( $WER_{up}$ ), Word Error Rate downlink ( $WER_{down}$ ), Quality Indication uplink ( $QI_{up}$ ), Quality Indication downlink ( $QI_{down}$ ), Time Differential uplink ( $TD_{up}$ ), Time Differential downlink ( $TD_{down}$ ), initial and instantaneous power levels, etc. and distance from the base station.

Still referring to Figure 5, it is seen further that positioning system 90 includes a Location Adjunct Processor (LAP) 102. The LAP may be an Intelligent Peripheral (IP) or other suitable device which is in electrical communication with the location databank 100 and control unit 96. The LAP 102 is operative to access the location databank 100 and determine and forward the location of the mobile unit 94 to the control unit 96.

As shown, positioning system 90 is directed for use with the Public Switched Telephone Network (PSTN) 98 which is provided in electrical communication with the control unit 96. Control unit 96 is therefore operative to receive calls forwarded by base stations 92, temporarily suspended call processing, and generate call information request signals. The LAP 102 receives the call information request signals, accesses location databank 100 and determines and forwards the location of the mobile unit to the control unit 96. The call is thereafter forwarded to the PSTN 98 along with the determined mobile unit location.

Figure 6 of the drawings illustrates yet another positioning system 104 which is also directed for use with the present invention. System 104 is shown in a modified Advanced Intelligent Network (AIN) and is operative to handle both cellular and PCS calls. System 104 includes at least one PCS Radio Port 106 which is provided in electrical communication with a control unit 108 such as a Radio Port Controller or Radio Access System Controller for receiving PCS calls from a PCS subscriber 110. Similarly, a traditional power base station including a cellular tower 112 is provided in electrical communication with MTSC 114 for receiving cellular calls from cellular mobile unit 116. Both RPC 108 and MTSC 114 are provided in electrical communication with Service Switching Point (SSP) 118 which in turn is provided in electrical communication with Service Control Point (SCP) 120 through Service Transfer Point (STP) 122. RPC 108 and SCP 120 are further provided in electrical communication with a Location Adjunct Processor (LAP) such as Intelligent Peripheral (IP) 124.

As those skilled in the art will recognize, Service Switching Points 118 are generally nodes (usually the subscriber's local switch/central office switch) that recognize the "triggers" used when a subscriber invokes an Intelligent Network Service and then communicates with the SCP 120 to operate the service. Service Control Point 120 is similarly a node which contains the service logic and associated data support to execute the required customer services. Finally, Service Transfer Point 122 is a packet switch used to route signaling messages within the Advanced Intelligent Network. These packet switching elements are known to those having ordinary skill in the art and will, therefore, not be discussed in further detail.

In keeping with the invention, SCP 120 is operative to invoke a Service Logic Program (SLP). SSP 118 is further operative to temporarily suspend call processing and send a call information request signal to SCP 120 via STP 122 so as to invoke the SLP. Standard AIN messages, such as Play\_Announcement and Collect\_Digits can be utilized to request RF measurement data to be sent over the signalling system to the SLP, and from the SCP 120 to the IP 124. The IP-SCP API can be implemented using any mutually agreed-upon message set, such as Structured Query Language (SQL), which is supported by most vendors. Alternatively, the following messages could be used to define the IP-SCP API:

- getData: SCP requests data from the IP (or LAP),
- getDataResult: IP (LAP) sends requested data to the SCP,
- sendData: SCP sends updated data to the IP (LAP),
- sendDataResult: IP (LAP) responds with status of SCP's update request.

EP 0 705 046 A2

```

5      getData      OPERATION
PARAMETER      SEQUENCE {
                serviceKey      ServiceKey,
                securityIdentifier SecurityIdentifier OPTIONAL,
                requestedDataElements DataElementList
                }
10     RESULT      SEQUENCE {
                resultType      ResultType,
                dataElementsReturned DataElementBlock
                }
15     ERRORS      {
                missingCustomerRecord,
                dataUnavailable,
                taskRefused,
                unauthorizedRequest,
                generalFailure,
20     timerExpired,
                systemNotResponding,
                incompatibleVersions,
                queueFull,
                resultsTooLong
25     }
        ::=59137

30     sendData    OPERATION
PARAMETER      SEQUENCE {
                serviceKey      ServiceKey,
                securityIdentifier SecurityIdentifier OPTIONAL,
                updateDataElements DataElementBlock
                }
35     RESULT      SEQUENCE {
                resultType      ResultType,
                dataElementsUpdated DataElementBlock
                }
40     ERRORS      {
                missingCustomerRecord,
                dataUnavailable,
                unauthorizedRequest,
                generalFailure,
45     timerExpired,
                systemNotResponding,
                incompatibleVersions,
                queueFull,
                }
50     ::=59138

        generalFailure      ERROR ::= 1
        missingCustomerRecord ERROR ::= 4

```

55

EP 0 705 046 A2

```
5      dataUnavailable      ERROR ::= 6
      taskRefused          ERROR ::= 7
      queueFull            ERROR ::= 8
      timerExpired         ERROR ::= 10
      systemNotResponding ERROR ::= 15
      unauthorizedRequest  ERROR ::= 20
10     incompatibleVersions ERROR ::= 60
      resultsTooLong      ERROR ::= 61

      ServiceKey ::= [10] CHOICE {
15         lineNumber [0] IMPLICIT Digits
         -- other types of service keys may be added in the future
      }

      DataElementList ::= SET OF ElementIdentifier

20     ResultType ::= [203] IMPLICIT ENUMERATED {
         completeSuccess (0),
         partialSuccess (1),
         completeFailure (2)
25     }

      DataElementBlock ::= SET OF DataElement

      DataElement ::= SEQUENCE {
30         elementIdentifier ElementIdentifier,
         elementValue      ElementValue
      }

      ElementIdentifier ::= INTEGER

35     ElementValue ::= CHOICE {
         elementError [0] IMPLICIT ElementError,
         elementData [1] ElementData
      }
40     ElementError ::= ENUMERATED {
         ee-successfulUpdate      (0),
         ee-generalFailure        (1),
         ee-missingCustomerRecord (4),
         ee-dataUnavailable       (6),
45         ee-taskRefused          (7),
         ee-timerExpired          (10),
         ee-systemNotResponding   (15),
         ee-unauthorizedRequest    (20),
50     }

55
```



```

ElementData ::= CHOICE {
    5     elemBoolean [0] IMPLICIT BOOLEAN,
        elemInteger [1] IMPLICIT INTEGER,
        elemString  [2] IMPLICIT OCTET STRING,
        elemDigits  [3] IMPLICIT Digits,
        elemReal    [4] IMPLICIT REAL,
    10    elemAindigits [5] IMPLICIT AINDigits

        -- possibly other standard types
    }

    15    Digits ::= OCTET STRING -- as defined in TR-246
        AINDigits ::= OCTET STRING -- as defined in TR-1285

        SecurityIdentifier ::= [202] CHOICE {
            20    pin [0] IMPLICIT Digits
        }

    END

```

25 The above text provides an example of a method of specifying the LAP-SCP interface using Abstract Syntax Notation 1 to define the get data and send data structure. A similar technique could be used to define the result messages.

A location databank 126 which is provided in electrical communication with Intelligent Peripheral 124 is operative to store real-time RF measurements for Radio Port 110 and/or cellular base station connected to cellular tower 112, including their link budgets. IP 124 is, however, operative to access the location databank 126 and determine and forward the location of the PCS mobile unit 110 or cellular mobile unit 116 to their respective control units, i.e., RPC 108 and MTSC 114, at the request of the SLP. As indicated above, in keeping with the invention, and with reference to the ANSI Stage 2 service architecture of Figures 3a-3b, the SLP can be used to embody the functions of the TMD 60, and/or the TMC 50 and/or PMC 62 and/or PMD 64 and/or RASC 40.

35 Referring now to Figure 7 of the drawings, yet another positioning system 128 is shown which is also directed for use with the present invention. Location transport system 128 is again adapted for use in the Public Switched Telephone Network (PSTN) and includes at least one end central office 130 which is provided in electrical communication with a plurality of Public Safety Answering Points (PSAPs) 132 and an Automatic Location Identification/Data Management system (ALI/DM) database 134 via an Enhanced 9-1-1 (E9-1-1) selective router 136. The location transport system 128 is operative to route E9-1-1 calls from mobile units 138 and, like the above embodiments, includes a plurality of base stations such as Radio Ports 140. Each of the base stations 140 is assigned a pseudo directory number which is uniquely associated with it. This number is stored in the ALI/DM database 134 along with its location. Each of the base stations 140 is operative to receive calls originating from one or more of mobile units 138 over air interface channels.

45 System 76 similarly includes a control unit 142 which as referenced above may be an MTSC when used in a cellular telephone network or an RPC or RASC, etc. when used in a PCS system as shown. Control unit 142 is operative to receive calls forwarded by base stations 140, temporarily suspend call processing, and generate a call information request signal. A location databank 144 is also provided which is operative to store the updatable real-time RF measurements for each of the base stations 140, including its link budget. Finally, a LAP 146 is provided in electrical communication with location databank 144 and control unit 142.

50 As in the above positioning systems, the LAP 146 is operative to receive a call information request signal, access the location databank 144 and determine and forward the location of a mobile unit 138 to the control unit 142. Unlike the above systems, however, here the call will thereafter be forwarded to one of the PSAPs 132 in accordance with the pseudo directory number or RPID or geographic phone number associated with the corresponding base station along with its determined location and the location of the mobile unit that originated the call.

55 Significantly, the above location information, i.e. the determined location of the mobile unit and the location of the corresponding base station may be forwarded to the PSAP 132 as a text description, video description, data point description or any other suitable informative means. A voice synthesizer 148 may also be provided in electrical communication with PSAPs 80 which is operative to audibly announce the location of the mobile unit that originated the call. In operation,

## EP 0 705 046 A2

voice synthesizer 148 will announce location to a PSAPs 132. In addition, the call will be routed to the correct PSAP and the base station's location will be displayed on the PSAP terminal, thus requiring no new equipment or functionality.

As those skilled in the art will recognize, wireline 9-1-1 calls are routed to the correct PSAP 132 via a TN/ESN translation in the E9-1-1 selective router 136. Each directory number (or terminal number) is associated with an emergency service number, which in turn is associated with a trunk group terminating to the correct PSAP. The location of the directory number is determined by the E9-1-1 selective router 136 via a database look up in the ALI/DMS (Automotive Location Identification/Data Management System) database. The ALI/DMS stores the location of each directory number, allowing the E9-1-1 selective router to forward this location to the PSAP.

Because wireless handsets, i.e. mobile units 138, do not contain an entry in the TN/ESN translation or the ALI/DMS system, wireless calls must be switched through the end central office/PCS switching center 130 using a pseudo directory number uniquely associated with the base station 140. Each of these pseudo directory numbers is therefore stored in both the TN/ESN and the ALI/DMS systems. This will allow for the base station's location to be displayed at the PSAP 132, while the location of the mobile unit 138 and callback number is announced using the voice synthesizer 148 or similar means.

In the above voice synthesis approach, after PSAP answer supervision, but before PCS caller receipt of PSAP answer supervision, and in-band voice synthesizer device 148 provides the location information. The device temporarily bridges onto the forward channel, announcing location to the PSAP attendant, while the PCS caller 138 hears ringing tones. Applicants contemplate that a location announcement would take between 5-8 seconds, which at present, appears to be a reasonable amount of time. This voice synthesis alternative would require a new PCS call-control function. After receipt of the PSAP answer supervision signal at the location calculation point, this signal would be temporarily stored in advance while the voice synthesizer or similar means 148 outputs the location information to the PSAP 132. Alternatively, the PCS caller may be allowed to hear the location information during its emission.

As a further alternative, either the PSAP attendant or PCS caller may press one or more Dual Tone Multi-Frequency (DTMF) keys, prompts or numbers during the voice connection which is monitored by the location processor. Upon the detecting the presence of these numbers, a new location calculation is made and subsequently announced to either or both of the PSAP and the PCS caller parties. Such use may be required, for example, where the transmission of the original location information was not properly received due to interference or the like or where for other reasons, a confirmation of location position is desired.

Applicants further contemplate that location information may also be provided to control unit 142 and ultimately a PSAP 132 through the use of a modem 154 connection to LAP 146 and selective router 136 as shown in Figure 7. In this manner, an ASCII modem signal tone burst would be used, in which case special CPE modifications would be required to decode pseudo in-band location information and present it to the PSAP attendant. The tone burst could be sent between the first and second ring at the PSAP 132 (if this information space is not already in use), or immediately after PSAP answer and also before ringing tones cease from the PCS caller's perspective -- some call control answer supervision and delay would also be needed in this case.

Still further, applicants contemplate the transfer of location information from the LAP to the PSAP 132 or similar receptor, such as a police station, hospital, etc. via a broadband network. The broadband network may be comprised of a variety of point-to-point or switching devices, for example, a point-to-point cable modem using FDDI between two cable modems and a IEEE 802.3 ethernet interface or similar means between the LAP 146 and the cable modem on the near end and a similar interface between the cable modem and the PSAP interface or similar means.

Still further, applicants contemplate the utilization of transaction-based or similar data circuit techniques to transport PCS caller location information to the PSAP 132. The system may also be used to provide location transport along with other desired information, i.e., charts, schematics, etc., between one or more users, one or both of which may be mobile units.

Yet still further, applicants contemplate that each of the above positioning systems may be modified for use with the present invention such that location information may be provided directly to the mobile unit user in addition to or instead of the PSTN/PSAP attendant. For example, when using a Personal Digital Assistant (PDA), a user may desire his or her location and may simply call a specified telephone number which will provide the PDA in communication with a location adjunct processor. The location adjunct processor will thereafter perform call location calculations based upon RF measurements in accordance with the teachings of the present invention and forward the resultant location information directly to the PDA whereupon it may be displayed or audibly announced.

### Location Processing

Each of the systems referenced above requires detailed location processing utilizing scaled contour shapes which are modeled based upon determined RF measurements for each base station. The location processing of the present invention focuses on the ability to predict and model RF contours using actual RF measurements, then performing data reduction techniques such as curve fitting techniques, Bollinger Bands, and Genetic Algorithms, in order to locate a mobile unit and disseminate its location. An example of a suitable software analysis tool is a program by Axcelis, Inc.

termed "Evolver 2.0". This is an Axcelis spreadsheet program that can perform a genetic algorithm optimization of the parameters generated in the above curve fitting techniques.

More specifically, and with reference to Figure 8 of the drawings, the method steps include modeling 156 determined RF measurements for each of the base stations as a scaled contour shape having minimum and maximum boundaries which is capable of being projected on a mapping system such as an orthophotograph which may be digitally recorded. Thereafter, it must be determined 158 which of the base stations can be "heard" by the mobile unit, i.e., which base stations are neighbors of the mobile unit. Once this information is known, it may further be determined 160 where the corresponding contours of the neighbor base stations intersect so as to define a bounding polygon area that describes the position of the mobile unit in terms of a minimum and maximum error estimate.

Once the above information is known, the center of the bounding polygon area formed by the intersection of the projected contours of the neighbor base stations may further be determined 162. From this information, the latitude and longitude for this center may be calculated 164 and there may be further determined 166 in cooperation with a location databank, the exact street addresses contained within the bounding polygon area.

As readily seen, a key component of the present invention is the ability to diagram and model the RF propagation loss from a given Base Station/Radio Port, for various RF measurement arc segments, which will define entire contours. As those skilled in the art will recognize, in theory, if the "free space" power loss is known for all useful distances in all directions from a base station, then individual circular power loss contour shapes may be drawn around the base station. Assuming two or preferably three base stations are neighbors of the mobile unit, then RF measurements may be used to determine location via intersecting contours. The particular shape of the contour intersections is the bounding polygon that describes the location, in terms of the maximum error estimate.

Unfortunately, the principle of free space loss rarely exists when attempting to predict base station coverage areas since the surrounding buildings, trees, traffic signs and other geographical "clutter" blocks transmitted signals. To account for these variables involved in propagation prediction, the present invention therefore utilizes a number of segmented models and analysis techniques for data reduction purposes. The resulting output becomes the location databank which consists of a collection of component databases, many of which may be designed on a per base station basis. The component databases may include a base station database, a prediction database, a measured RF database, a generic curve fit database, a Bollinger band database, equipment-specific corrections database, and a run-time database as described in further detail below.

**Base Station Database**

In keeping with the invention, the base station database provides a detailed list of the attributes of every installed and proposed base station. Applicants contemplate that this database would contain the following data elements:

1. Name or identification of base station.
2. Base station vendor name, model number, serial number.
3. Latitude (LAT), Longitude (LONG), or at least accurate street location detail for conversion to/from LAT and LONG, and Altitude (ALT) of physical placement of base station.
4. Base station transmitter default power, instantaneous power for each active transmission channel, and power range.
5. Antenna gain contours (if omni-directional, otherwise sector make-up, and gains within each sector).
6. Whether or not a distributed antenna scheme is used, and if so, placement (LAT, LONG, ALT) of all remote antennas.
7. Nearby surrounding obstructions (e.g., the mounting surface of the RP: is it on a metal wall, in an elevator, or hanging in free space).
8. Base station transmitter operating frequency band (licensed, unlicensed), and allowed frequencies.
9. Whether or not a duplicated transmitter is used, and if so, include the identifying characteristics of each transmitter.
10. The PSAP associated with each base station.
11. Type of air interface: protocol and signaling (e.g., PACS, CDMA, GSM, DECT, CDMA, PHS-PHP, IS-54, IS-95, PCS-1900, B-CDMA, etc.) This information should be derived from the base station vendor name, model number, and serial number. Any dual or multi-mode capabilities must also be known and characterized.
12. Base station antenna gain contour. This information could be derivable from knowledge about the antenna's characteristics and surrounding obstructions.
13. The control unit associated with the base station, neighboring communication network topology and the associated central office. This information may be derived from knowledge of the control unit and its connected central office at the time the wireless communication system is originally engineered. Nonetheless, the network topology may change, due to a variety of reasons. For example, future base stations may use a signaling protocol arrangement with their control unit such that the base station can be easily moved around without prior notification to a centralized work manager system. A control unit may automatically discover the addition/deletion or in/out change of a particular

## EP 0 705 046 A2

base station. To the extent this automatic capability exists, a forwarding event report message must be sent to a system associated with the location service. In cases where the control unit is associated with a PBX, foreign exchange circuit, or similar remoting facility, the identification and end-to-end topology circuit arrangements will be needed.

5 14. Frequency Assignment Characterization (FAC). This should be derivable from the RP vendor, make/model information. If the FAC is automatic, then a potential incompatibility may exist during the performance of the location function. Knowing these details, and/or having the ability to control the occurrences of frequency assignment, can resolve incompatibilities.

10 15. Current operational RP status. This information should be derivable from the wireless communication network OAM and P systems that should routinely receive current information about the in-service state of the base stations. This information is needed, for example, because a planned, but not in-service base station, or a faulty base station, could disturb the location algorithm, if this information is otherwise not known.

15 16. Traffic load characteristics of the base station and its superior network. This may be derivable from the network planning activity, base station model characteristics, and dynamic monitoring by OAM and P systems, or each base station. For example, if a base station needed to perform an emergency location function, it cannot be invoked because it is at 100% of capacity, with no possibility to shed "non-emergency" load, then other techniques may be applied.

### Prediction Database

20

This is a planning database primarily populated by, and used to support/interact with base station site planners and installation engineers. In accordance with the invention, it is used primarily to predict coverage. The location function accesses this database in order to require a rudimentary understanding of intended coverage area of newly planned cell sites and their operational status. Using the various RF propagation models and special plane curves, propagation coverage will be predicted for all base stations by examining the placement of the base station, local street widths, and the surrounding clutter. This provides a quick, inexpensive estimate of each base station's coverage.

25

### Measured RF Database

30

In keeping with the invention, the measured RF database consists of actual measurements taken from the area surrounding the base station. These measurements could be taken by technicians during base station site installation or any other collection technique. Both uplink (handset to base station) and downlink (base station to handset) measurements will be made for data such as Received Signal Strength Indicator (RSSI), Word Error Rate (WER), Quality Indicator (QI), and Time Differential. Each of these variables are known to those skilled in the art and will therefore not be discussed in further detail. These measurements will be recorded along with the exact location at which the measurements were taken. All measurements are made within an arc segment region as discussed in further detail below.

35

### Generic Curve Fit Database

40

This database is contemplated for use in accordance with the invention when no equipment-specific data is required/available. The generic curve fit database is created in the following manner:

45 1. Using the measurements database, load the data for each measurement type (i.e.  $RSSI_{down}$ ), per an arc segment region, and per a base station, into a curve fitting program. One such program known to applicants is *Table Curve 2D* distributed by Jandel Scientific Software. Using any random or pseudo-random method, "holdback" 15% of the data points from the curve-fitting exercise, to be used as verification points later. This process will produce an equation for each measurement type, per region.

50 2. Inspect the resulting graphs for each measurement. Measurements that produce smooth, well-fit curves will be noted.

55 3. Simultaneously inspect all graphs for a given region. If one measurement produces a much smoother graph than the others, determining location in that region will require only one parameter. Alternatively, there may be areas within the region that correlate well with some measurements and poorly with others. As shown in Figure 9, for example, it can be seen that the correlation in area A is fairly good for WER and poor for RSSI. Similarly, the correlation in area B is good for RSSI and poor for WER. These graphs suggest that determining location will require multiple parameters. In the example of Figure 9, WER would be used in areas A and D, RSSI would be used in area B, and another measurement would be used in area C.

4. Test the equations by using the data points that were excluded from step 1. If the results are satisfactory, go on to the next step. If the error-bounds are too large using the existing equations, it may be necessary to use genetic

algorithms to enhance the predictive technique for the region. Genetic algorithms could be used here to simultaneously combine the six (or more) equations in every conceivable manner to produce the best fit.

5. Store the equations for each region in the location databank for use during a location request, along with the error estimate.

5

By analyzing the surrounding characteristics for each model region (i.e. street width, distance from base station to nearest building, etc.) along with a corresponding location equation, it may be possible to reuse this information in a predictive manner for future base station installations. Applicants contemplate that this could reduce costly manual RF measurement testing.

10

**Bollinger Bands**

As known to those skilled in the art, the basic idea behind Bollinger Bands is to read data points and create a moving average and a moving standard deviation. The bands are determined by calculating the average of a certain number of data points plus and minus two times the standard deviation of the data. A "sliding window" is used for the volatility of the data. The optimal window size will vary with the condition of the data.

15

As shown in Figure 10, Bollinger Bands provide: (1) the ability to handle discontinuities and vast multi-model, noisy search spaces; and (2) they optimize error wherever possible, i.e., wherever field measurements have a low volatility, then Bollinger Bands will generally have a low bandwidth, which results in a more accurate bounding polygon.

20

In accordance with the present invention and as explained in further detail below, RF measurements will be analyzed using the Bollinger band technique in the following manner:

1. Load the data for each measurement type (i.e. RSSI downlink), per arc segment region, into a program to calculate the sliding window average and standard deviation.

25

2. For each distinct measurement value (e.g. -70 Db, -71 Db, -72dB, etc.), store the measurement value and the corresponding average distance (in feet) in both the upper and lower band (in feet), based on the sliding window.

**Equipment-Specific Corrections Database**

This database is contemplated for use with the present invention if vendor-specific, and/or model-specific equipment characteristics are available and are used in the areas of interest, which deviate from the generic curve fit database assumptions. For example, in GSM, different vendors use slightly different mapping or transfer functions, in relating true Word Error Rate, with the vendor's quantized indicator. It is anticipated that public, open standards will be defined, that mitigate the need for the Equipment-Specific Corrections Database. Data for this database would normally be provided from lab tests performed by mobile unit manufacturers, which are then used for correction purposes with respect to the generic curve fit database, and its assumed internal baseline standard.

30

35

**Run-Time Database**

This database is contemplated by Applicants to be stored directly in the format of the GIS software being used (e.g. map info or ARC/info). It is derived from the data reduction processes, for example, the curve-fitting in Bollinger Band databases. Each arc segment per base station contains a number of entries. The first entry defines the independent variables used to calculate location within this arc segment. There is also one entry for each distinct measurement value of the independent variables selected (e.g. RSSI down = -70dB, -71dB, -72dB, etc.) These entries are actually graphical objects (bounding polygons) that are selectable by the GIS software.

40

45

For example, with reference to Figure 11 and the table below, assume the curve fitting in Bollinger Band analysis for base station 1 has determined that  $RSSI_{up}$  is the best location predictor for arc segments 1, 2 and 3, while  $WER_{down}$

50

55

**EP 0 705 046 A2**

is the best predictor for arc segments 4 and 5. The run-time database would contain the following entries:

5

| RUN-TIME DATABASE |                     |
|-------------------|---------------------|
| Arc Segment       | Predictor Variable  |
| 1                 | RSSI <sub>up</sub>  |
| 2                 | RSSI <sub>up</sub>  |
| 3                 | RSSI <sub>up</sub>  |
| 4                 | WER <sub>down</sub> |
| 5                 | WER <sub>down</sub> |

10

15

In addition, the database would contain many bounding polygons per arc segment. Figure 11 illustrates this concept for the five arc segments mentioned. In this Figure, the bounding polygons for RSSI<sub>up</sub> values of -70dB, -71dB and -72dB are displayed for arc segments 1-3. Additionally, the bounding polygons for WER down values of 1.1% and 1.2% are displayed for arc segments 4 and 5. While only 2-3 bounding polygons per arc segment are displayed in the Figure, there would actually be many polygons to cover the entire range for variable being used.

20

The run-time database is displayed with one predictor variable per arc segment as shown above. The Position Location System (PLS) process will actually use more than one predictor variable per arc when a single variable does not reliably predict distance. The runtime database for each arc segment will be constructed by using the results of the curve fit and Bollinger band databases, and will actually consist of two tables. The first table will be used to construct a set of fuzzy logic rules, while the second table will provide a predicted distance value, along with a minimum and maximum boundary.

25

For example, if arc segment 1 of radio port 5 is predicted well by RSSI<sub>down</sub> for values of -40 dB to -70 dB, and WER<sub>down</sub> for values of 1% to 3%, the following entries would appear in the run-time database rule table:

30

TABLE 1

| Run-Time Database Rule Table |             |                      |           |           |
|------------------------------|-------------|----------------------|-----------|-----------|
| Radio Port                   | Arc Segment | Variable             | Min Range | Max Range |
| 5                            | 1           | RSSI <sub>down</sub> | -40       | -70       |
| 5                            | 1           | WER <sub>down</sub>  | 1.0       | 3.0       |

35

40

The second table for arc segment one would contain entries such as these:

TABLE 2

| Run-Time Database Values Table |             |                      |       |           |          |          |
|--------------------------------|-------------|----------------------|-------|-----------|----------|----------|
| Radio Port                     | Arc Segment | Variable             | Value | Mean Dist | Min Dist | Max Dist |
| 5                              | 1           | RSSI <sub>down</sub> | -40   | 100       | 0        | 200      |
| 5                              | 1           | RSSI <sub>down</sub> | -41   | 120       | 20       | 220      |
| 5                              | 1           | RSSI <sub>down</sub> | ...   | ...       | ...      | ...      |
| 5                              | 1           | RSSI <sub>down</sub> | -70   | 500       | 400      | 600      |
| 5                              | 1           | WER <sub>down</sub>  | 1.0   | 400       | 350      | 450      |
| 5                              | 1           | WER <sub>down</sub>  | 1.1   | 440       | 390      | 490      |
| 5                              | 1           | WER <sub>down</sub>  | ...   | ...       | ...      | ...      |
| 5                              | 1           | WER <sub>down</sub>  | 3.0   | 800       | 700      | 900      |

45

50

55

## EP 0 705 046 A2

During a location request, the LAP would access the run-time database rules table and construct the following code to determine the caller's predicted distance from radio port 5 for arc segment 1:

### Pseudo-code:

```
5
rule_1 = FALSE
rule_2 = FALSE

10
/* look for active rules */

if -70 <= RSSIdown <= -40 then
  rule_1 = TRUE
15
if 1.0 <= WERdown <= 3.0 then
  rule_2 = TRUE

if rule_1 is TRUE and rule_2 is TRUE
  /* both rules apply, so we have to perform a weighted average using
  the difference between predicted max and min */
20
  weight_1 = (RSSIdownmax-RSSIdownmin) /
              (RSSIdownmax-RSSIdownmin+WERdownmax-WERdownmean)

25

  weight_2 = (WERdownmax-WERdownmin) /
              (RSSIdownmax-RSSIdownmin+WERdownmax-WERdownmean)

30
  /* reverse the weights because the one with the smaller difference
  is better and should be weighted more heavily */
  mean = weight_1*WERdownmean + weight_2*RSSIdownmean
  min = weight_1*WERdownmin + weight_2*RSSIdownmin
35
  max = weight_1*WERdownmax + weight_2*RSSIdownmax

else if rule_1 is TRUE
  use RSSIdown mean, min and max
else
40
  use WERdown mean, min and max
```

45 The detailed steps of preparing the run-time database and thus the PCS location databank may be illustrated with reference to Figure 12 of the drawings. Figure 12 is a schematic diagram of a Radio Port that has arc-segments 168 of 6 degrees. The arc-segments create discrete sections of the area around the Radio Port. With these sections clearly defined, the RF behavior of the Radio Port can be characterized in each section independently. After the locations have been partitioned into arc-segments, a spreadsheet file can be produced for each arc-segment.

50 The preparation steps include the initial gathering of field data. The desired parameters (RSSI<sub>up</sub>, RSSI<sub>down</sub>, WER<sub>up</sub>, WER<sub>down</sub>, QI<sub>up</sub>, QI<sub>down</sub>, etc.) will be collected at locations surrounding the Radio Ports. In a preferred embodiment, these locations will be approximately 10 meters apart from one another. All measurements will be placed with location tags in a suitable spreadsheet file such as, for example, Microsoft Excel.

55 The locations will thereafter be partitioned into arc segments 168 as indicated above. In keeping with the invention, the locations need to be partitioned into arc segments 168 in order to accurately model the parameters around corresponding Radio Ports. After the data has been collected and partitioned into arc segments, a suitable curve fitting program such as *Table-Curve 2D* will be used to curve-fit the data (distance versus each parameter) for each individual arc-segment. The software generates a list of functions that could possibly characterize the data and sorts the functions (best to worse) by means of lowest Fit Standard Error (FitStdErr).

Sometimes, the best fit (lowest FitStdErr) that the curve-fitting software packages produces is not the best fit for the RF data. There are many different examples of the software package fitting a curve to the data that is not physical (not possible in the RF environment). Some examples of non-physical fits are fits that swing into negative distances, fits that have high sinusoidal content, and fits that have many slope reversals or large swings in areas where few or no actual data points reside.

Figure 13 illustrates two *TableCurve 2D* curve-fit on the same data. The plot on the left shows the curve-fit that the software package chose as the best fit (it is the fit with the lowest FitStdErr). One skilled in the art would recognize that the plot on the left is highly unlikely to be representative of the data because of the large swings where few data points lie. With the data from Figure 13, a manual search for the most logical fit is needed. One skilled in the art would therefore search the fits until she found a fit that is more logical (like the fit on the right in Figure 13).

Figure 14 provides another example of a *TableCurve 2D* fit that is not logical. The fit on the left has one swing to a very large distance (off of the top of the plot) in an area where there are no data points. The plot on the right is much more likely to describe the data accurately in the area where there are no data points, even though it has a higher FitStdErr than the plot on the left.

Figure 15 illustrates yet another fit (left) that has a large negative distance swing (again, where no data points lie) and a sharp, large positive distance swing. In keeping with the invention, negative distances are not valid because they do not represent the RF environment properly. The sharp, large distance swing is not reliable because of the low number of data points in the area. The plot on the right has a much higher probability of being accurate.

The lowest FitStdErr fit in Figure 16 displays a more subtle problem. The points along the distance axis (vertical) are not well represented, yet they make up the majority of the data point population. The plot on the right better represents those data and also eliminates questionable swings that are in the left plot.

Although manually searching for the most logical fit may result in a larger FitStdErr, the fit will also be more representative of the actual RF environment. The number of invalid fits by *TableCurve 2D*, for example, can be minimized by collecting a high number (50-60) of evenly spaced data points within each arc-segment.

After the curve fitting program produces a valid fit, 95% confidence intervals (or bands) can be created. These bands (minimum and maximum) are produced by adding and subtracting twice the FitStdErr to the average fit. Any negative distances will be eliminated from the band. Figure 17 shows a best fit with maximum and minimum confidence bands. It should be noted that through simple numeric integration, the area of the interval can be computed. The area of the band will describe how volatile the data is throughout a complete arc-segment.

After the confidence intervals have been determined, Bollinger bands can be created for the data in each arc-segment 168. As indicated above, Bollinger bands are similar to the confidence intervals in that they represent a range in which data points are likely to reside. However, Bollinger bands widen according to the volatility of the data in a certain area of a particular arc-segment. Basically, the Bollinger interval is wide in areas where the deviation of the data points is large, and is narrow in areas where the deviation of the data points is small. Figure 18 shows how Bollinger bands widen in areas of data volatility.

As discussed above, Bollinger bands use a "sliding window" technique to compute a moving average across a data set. The sliding window size for location purposes will be 20% of the data population for each arc-segment. As with confidence intervals, the area of the Bollinger bands can be computed through simple numeric integration. The advantage of the Bollinger band over the confidence interval is that the area of the Bollinger band in a discrete section of an arc-segment can describe the volatility of the data in that section. The area of the confidence interval can only describe the volatility of the data throughout a complete arc-segment.

A problem with Bollinger bands is that they have a phase lag that is introduced in calculating the moving average. Because of this phase lag, the Bollinger band widens slightly beyond the volatile data. The amount of phase lag is dependent on the size of the sliding window.

To "clip" the phase lag, the Bollinger band and confidence intervals can be intersected. The intersection of these two bands becomes the location or distance band 170, as shown in Figure 19. The location band 170 is what will be used to generate (for the location databank) minimum and maximum distances for any valid values of any of the parameters. The area of the location band 170 can be computed with simple numeric integration and is an indication of the data volatility.

At this stage, location bands have been produced for all parameters in each arc-segment. Now, a method of determining which parameters to use is needed. Fuzzy logic will be used to determine which parameters will be used when estimating a distance. Fuzzy logic, as known to those skilled in the art, consists of fuzzy patches or rules which try to explain the behavior of fuzzy systems. Fuzzy patches or rules are simply if-then-else statements that describe a discrete section of the system's output. The goal is to have a group of fuzzy patches that accurately describe the system's complete output. In this location system, fuzzy rules will be created to use the parameters with the least volatility to estimate a distance.

Figures 20 and 21 provide examples of two different parameters from the same arc-segment. An example of a fuzzy rule would be as follows: If  $RSSI_{\text{downlink}}$  reading lies in the range to the left of the dashed line, use  $RSSI_{\text{downlink}}$ . Otherwise, use  $WER_{\text{uplink}}$ .



The above fuzzy rule is an over-simplified case, yet it illustrates the idea behind fuzzy logic. With all parameters being used, weighted averaging can be used to implement a combination of parameters in the fuzzy model. Fuzzy logic is flexible in allowing different parameters to carry different weights. In the location system of the present invention, the weights for the fuzzy logic averaging will be determined by the volatility of the data (used the measure of the location band area). In the "gray" areas of overlapping fuzzy rules, the overlapping rules are added together (with associated weights) and then the average of the curve will be used.

By preparing several individual parameter bands to get the smallest volatility within a "quantization", the best solution may be determined. Finally, the final solution may be compiled using fuzzy logic technique values. For example, in the pseudo code above, each of the database entries is weighted against one another such that the database entry of minimum volatility having the strongest predictor of distance at a particular location for particular values is obtained where more than one rule applies.

As known to those skilled in the art, fuzzy logic is a process where, unlike neural networks, more than one rule applies. The rules are averages in a predetermined weighting scheme. Unlike normal fuzzy logic rules, however, the weighting here pertains to minimum and maximum values. In keeping with the invention, volatility is used as an indicator of the best weight. The variable with the least volatility is weighted the most, however, other variables are not discounted.

In this manner, overlapping RF measurements may be utilized. Thus, 80% of WER and 20% of RSSI might be used in predicting location. The system and method of the present invention averages the minimum distances as well as the maximum distances which then become the min and max boundaries for each arc segment. This process is repeated for all other arc segments which permit a min and max bounding polygon to be drawn around a Radio Port. The process is thereafter repeated for neighboring Radio Ports as they are "heard" to determine the most accurate predicted bounding contours for the other neighboring Radio Ports. The resulting contours (i.e. the minimum and maximum contours) are thereafter drawn around each Radio Port, the intersections of which define the bounding polygon where the mobile unit can be located.

Because the Radio Port data is partitioned into separate arc-segments and then analyzed, there will be discrete jumps in the data between arc-segments. To improve the continuity of the data between arc-segments, a line will be added to help smooth the jumps. The slope of this line will roughly be the magnitude of the jump divided by some  $\Delta X$  (where  $\Delta X$  is 10-20% of the width of the arc-segment).

In keeping with the invention, and by reference to Figure 22 of the drawings, the step of modeling the determined RF measurements as scaled contour shapes therefore requires segmenting the coverage areas of each of the base stations into a plurality of arc segments designated by reference numeral 168 in Figure 11. For each of the arc segments 168, a plurality of single or multiple regressions must be performed so as to convert actual data into a corresponding plurality of mathematical curve-fit equations each representing a relationship between a predetermined measurable variable, i.e. RSSI, WER, etc. and distance from the base station. For each of the arc segments, the degree of fit must be determined of the corresponding mathematical equation by comparing each of the mathematical equations with actual data. The mathematical equations may thereafter be optimized by determining which has the best correlation and least standard error for a predetermined portion of each arc segment 168.

A Genetic Algorithm (GA) may also be used to optimize the parameters of each of the single or multiple regressions so as to further improve the degree of fit for greater correlation and minimum standard error. Still further, in cases where there is generally poor correlation between all of the mathematical equations of an arc segment and the actual data, the corresponding base station may be instructed along with the receiver, i.e., the mobile unit, to each temporarily change their transmission frequencies by 10-40 MHz. Thereafter, additional RF measurements may be obtained for the base station at the changed frequency, including its link budget, for the same predetermined plurality of distances and directions. As readily seen, this will increase the number of variables for consideration and analysis.

The optimized mathematical equations for each arc segment are thereafter combined so as to form the scaled contours such as that shown in the schematic of Figure 23.

Each scaled contour has minimum and maximum bounds. After these boundaries have been determined for an entire base station, minimum/maximum boundaries also define minimum/maximum contours, based on a given set of real-time measurements in both the uplink and downlink directions. This process is repeated for neighboring base stations, and the resulting intersection (if any) then define a min/max bounding polygon.

The polygon is then projected onto a mapping system such as, for example, an orthophotograph which may be digitally recorded, or similar means, with nearby street names as shown, for example, in Figure 24. In a preferred embodiment, the entire picture may then be sent via a BRI-ISDN or FDDI circuit to a PC or workstation-based video collaboration system (or similar two-wave video system) When used in emergency situations, the video collaboration system would be located in the nearest PSAP. As shown in Figure 24, the location processing steps of the present invention may be used to locate a "victim" determined to be about midway along Maple Street, as it intersects with Elm Street. Because the bulk of the bounding polygon is along the North side of Maple Street, from an intuitive perspective, the "victim" is more likely to be on the North side of Maple Street.

In keeping with the invention, it should be noted that even in the degenerate case where only one base station's signal can be detected by the handset, min/max bounding bands around the base station, also projected on a high

quality digital orthophotograph, can provide superior information to the emergency call taker and the PSAP as opposed to merely providing the base station generic coverage area, as a circle. For example, Figure 25 shows that based on the RF measurements received, the "victim" cannot be at the same intersection as the base station itself, but rather elsewhere as shown. From a quick inspection of the bounding polygon, it is apparent that there is a strong possibility the "victim" is in Building 3 and less likely that the "victim" is in Building 2, or in the neighborhood park. This type of information, although unusual, could be used by search teams to be most efficient and fast in their task of actually finding the "victim" in accordance with the present invention even though only a very minimum amount of RF measurement data was available in real-time during the call.

Nonetheless, it should be noted that from a location accuracy and efficiency point, the above-described Integrated Services Digital Network (ISDN) approach which requires sending bounding polygon location via video, is contemplated to provide the user with the most accurate location details.

With reference to Figure 26 of the drawings, there is provided a schematic diagram of the generalized updating system of the present invention which is particularly suited for use with the positioning systems and location steps described in detail above. It should be understood, however, that the method and system of the present invention may be suitable for use with most interactive electronic devices such as the above-referenced Personal Digital Assistants (PDAs) and the like.

The updating system shown in Figure 26 is designated generally by reference numeral 192 and is directed for use in a wireless communication system which includes at least one base station such as radio port 194 in electrical communication with at least one mobile unit such as handset 196 within a corresponding coverage area. There is further provided a location databank 198 operative to store real-time RF measurements for base station/radio port 194, including its link budget in the manner discussed above.

The system includes a plurality of update centers 200 with known fixed locations within the base station coverage area. Each of the update centers 200 further includes an electronically readable device termed a "Geopad" 202 for purposes of the present invention. Each Geopad 202 is encoded with pre-calibrated location information, i.e. latitude, longitude, altitude, etc. for its corresponding update center. Significantly, in place of the electronically readable Geopad, applicants recognize that the update center may just as easily have printed information which is visually or electronically readable by a subscriber. The information may be provided to a central operations system by placing a specified call.

For example, in a metropolitan area, a number of update centers 200 may be placed at locations such as at telephone booths which will include printed information regarding the exact location, i.e. longitude, latitude, altitude, etc. along with a toll-free number which may be called by the subscriber. In operation, the subscriber could simply dial the identified number, orally identify the published location information and, at the same time, provide current RF measurements for the corresponding base station in order to update the location databank. Even more easily, the update centers could be identified by number and the user would simply provide this number to the service representative who would have stored location information for that update center based upon its assigned number.

In the embodiment where electronically readable Geopads are provided, an electronic reading device 204 must also be provided in electrical communication with the mobile units for decoding the encoded location information at the Geopads. The electronic reading device may be disposed within each of the mobile units or, in the alternative, may comprise part of the Geopad 202 itself. The Geopad could be a flexible passive sticker material containing pre-calibrated latitude, longitude, altitude above street level information and a special dial-in-telephone number, as encoded information in a bar code as shown in Figure 26, or magnetic, or other technology, such as that used in employee badge readers. The user could either enter the LAT, LONG, and ALT information via a keypad as indicated above, or if a bar code or other similar encoding means were used, then the user would also need a reading device.

Still referring to Figure 26 of the drawings, the system includes a Location Adjunct Processor (LAP) 206 in electrical communication with each of the base stations/radio ports 194 and the location databank 198, typically through a control unit 207. Processing logic 199 is also required in electrical communication with each of the mobile units. The processing logic must be operative to obtain the desired RF measurements at each of the Geopads 202 and initiate a call to the LAP 206 in order to transmit the measurements to the location databank 198 along with the decoded location information.

It is anticipated that for practical use, some incentive must be provided to mobile telephone users in order to encourage periodic updating of the location database. Such an incentive could, for example, take the form of a billing credit which would be provided as follows:

- (1) The mobile telephone handset 196 dials a special Geopad directory number which would preferably be toll free.
- (2) A predefined message traps and redirects the call control to the LAP 206.
- (3) The LAP 206 answers the call, sends tones/message requesting latitude and longitude.
- (4) The latitude and longitude is sent from the handset 196 to the LAP 206. The LAP 206 stores the results in a temporary holding database 208, gives the caller an acknowledgement and disconnects, for example, through the use of a voice synthesizer 209 or similar means such as a digitized announcement. The LAP sends a billing credit to the PSTN 210 and onward to a billing data collection center.

Periodically a routine may be performed to update the location databank with updated values based on Geopad data, stored in the holding database 208. The location databank would also be updated if any network elements are changed which influence the RF link budget. Examples include changing a base station antenna, changing transmitter power or adding/deleting a base station.

5 With reference now to Figure 27 of the drawings, there is further described the method of the present invention for updating a location database used in a wireless communication system to determine the location of a mobile unit. The wireless communication system includes a base station in electrical communication with at least one mobile unit within a corresponding coverage area.

10 As shown in Figure 27, the method comprises providing 212 a plurality of update centers at known fixed locations within the base station coverage area. Each of the update centers includes an electronically readable Geopad encoded with pre-calibrated location information for that center. By providing 214 an electronic reading device in electrical communication with the mobile unit, the encoded location information may be decoded 216 at the Geopads through the use of an electronic reading device.

15 The method further includes providing 218 processing logic in electrical communication with the mobile unit as well as providing 220 a control unit in electrical communication with the base station. Still further, the method includes providing 222 a Location Adjunct Processor in electrical communication with the control unit and providing 224 a holding database in electrical communication with the LAP and the location database. By making real-time measurements 226 at one of the Geopads and initiating a call to the LAP in cooperation with the processing logic, the RF measurements may be transmitted along with the decoded location information directly to the location databank, or, to the holding database for temporary storage, so as to provide the required periodic updating.

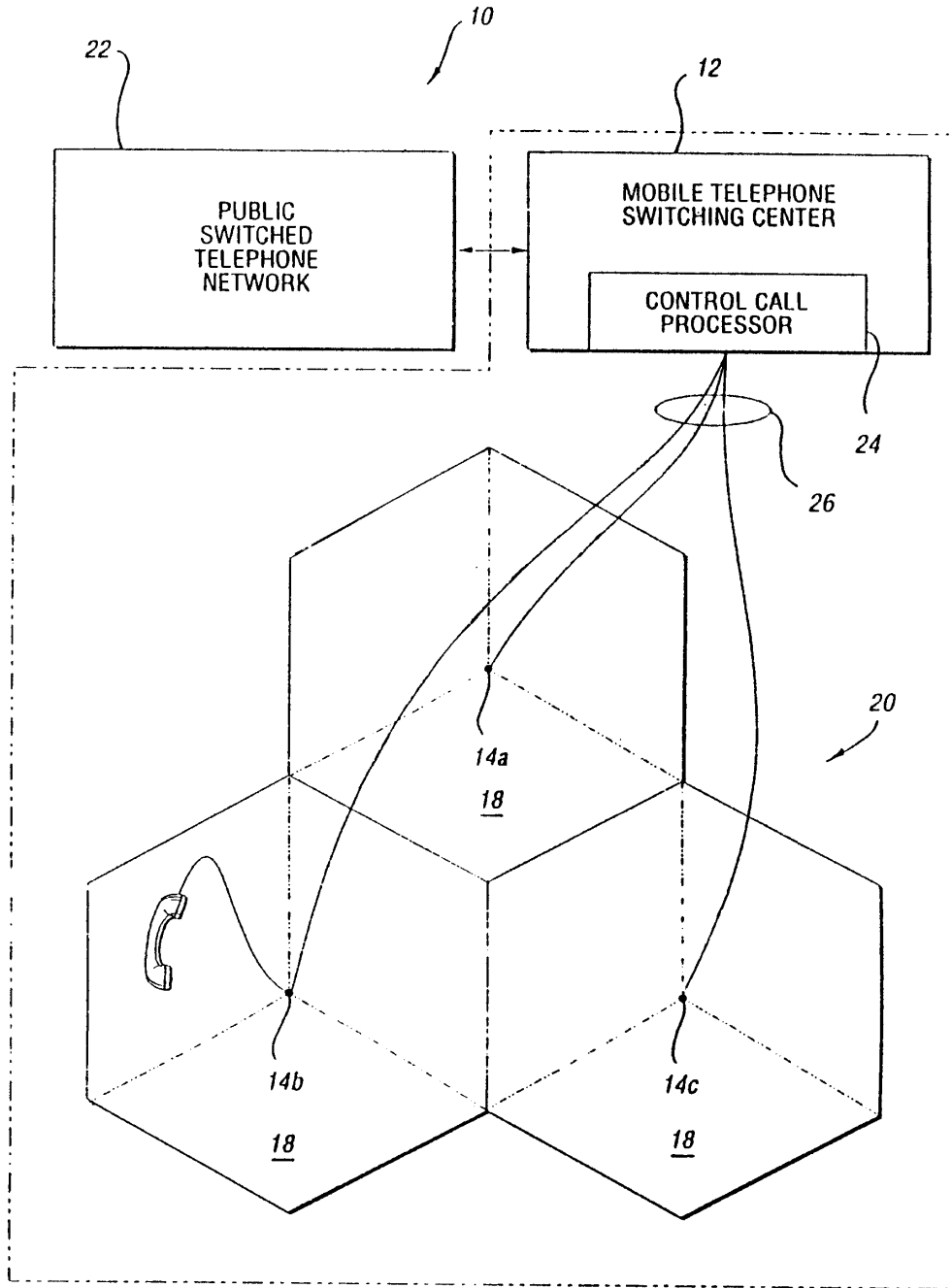
20 While the best mode for carrying out the invention has been described in detail, those familiar with the art to which this invention relates will recognize various alternative designs and embodiments for practicing the invention as defined by the following claims.

25 **Claims**

1. For use in cooperation with a wireless communication system, including a base station in electrical communication with at least one mobile unit within a corresponding coverage area, and a location databank operative to store real-time RF measurements for the base station, including its link budget, a system for updating the run-time database, comprising:
  - 30 a plurality of update centers at known fixed locations within the base station coverage area, each of the update centers including means for transmitting its own precalibrated location information to the location databank along with determined real-time RF measurements for the base station in cooperation with the at least one mobile unit.
  - 35 2. A system as in claim 1, wherein the means for transmitting precalibrated location information to the location databank along with the determined real-time RF measurements for the base station comprises:
    - 40 a plurality of electronically readable GeoPads, each of the GeoPads positioned at a corresponding update center and encoded with the precalibrated location information for that center;
    - an electronic reading device in electrical communication with the at least one mobile unit for decoding the encoded location information at each of the GeoPads;
    - a Location Adjunct Processor (LAP) in electrical communication with the base station and the location database; and
    - 45 processing logic in electrical communication with the at least one mobile unit, the processing logic operative to obtain the RF measurements at each of the GeoPads and initiate a call to the LAP to transmit said measurements to the location databank along with the decoded location information.
  3. A system as in claim 2, further comprising a holding database in electrical communication with the LAP and the location databank, the holding database operative to temporarily store the RF measurements and location information and periodically update the location databank.
  - 50 4. A system as in claim 2, wherein the plurality of electronically readable GeoPads are encoded with precalibrated location information through the use of bar codes.
  - 55 5. A system as in claim 2, wherein the processing logic is contained within the at least one mobile unit.
  6. A system as in claim 2, wherein the processing logic is contained within a Service Control Point (SCP).

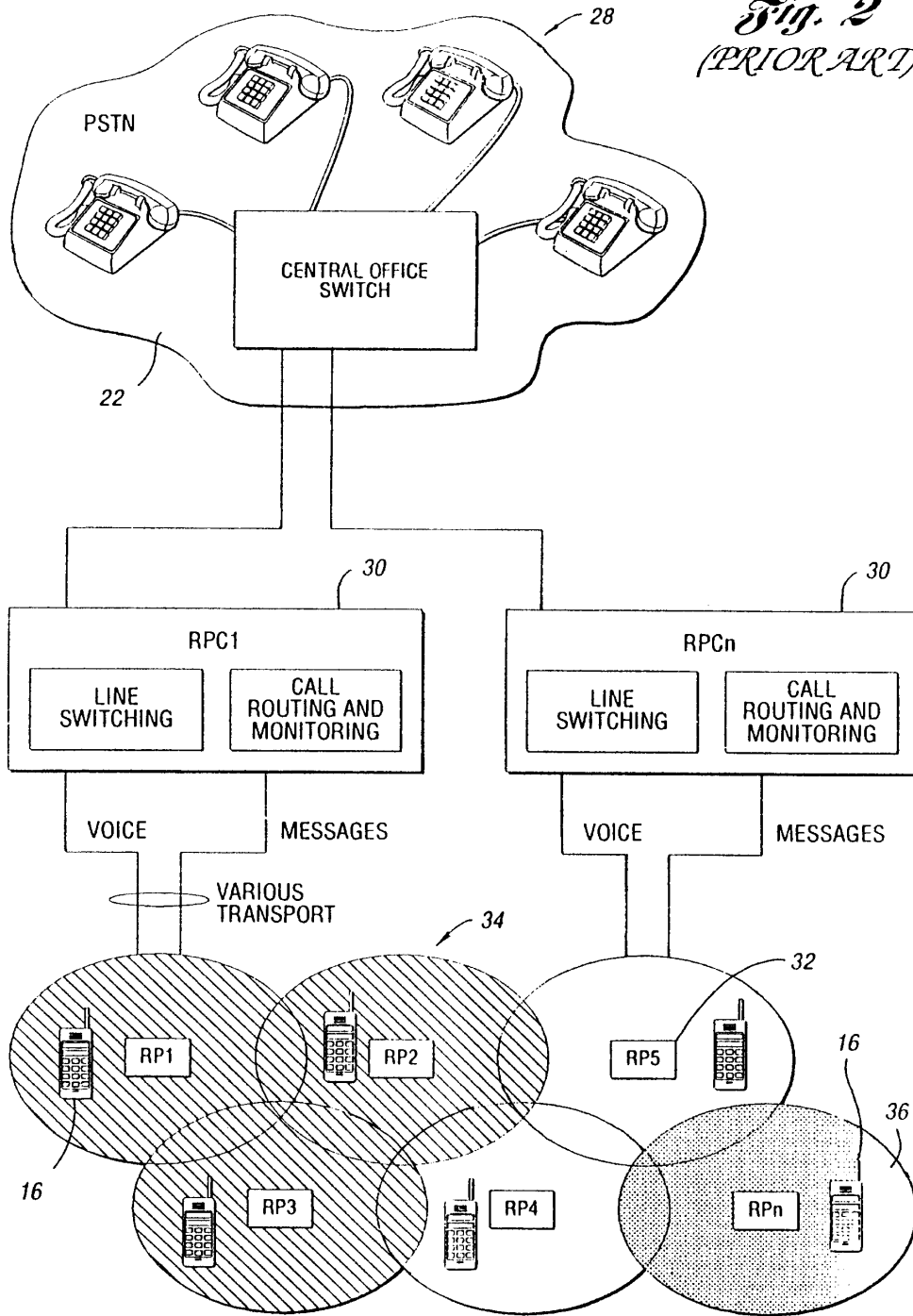
EP 0 705 046 A2

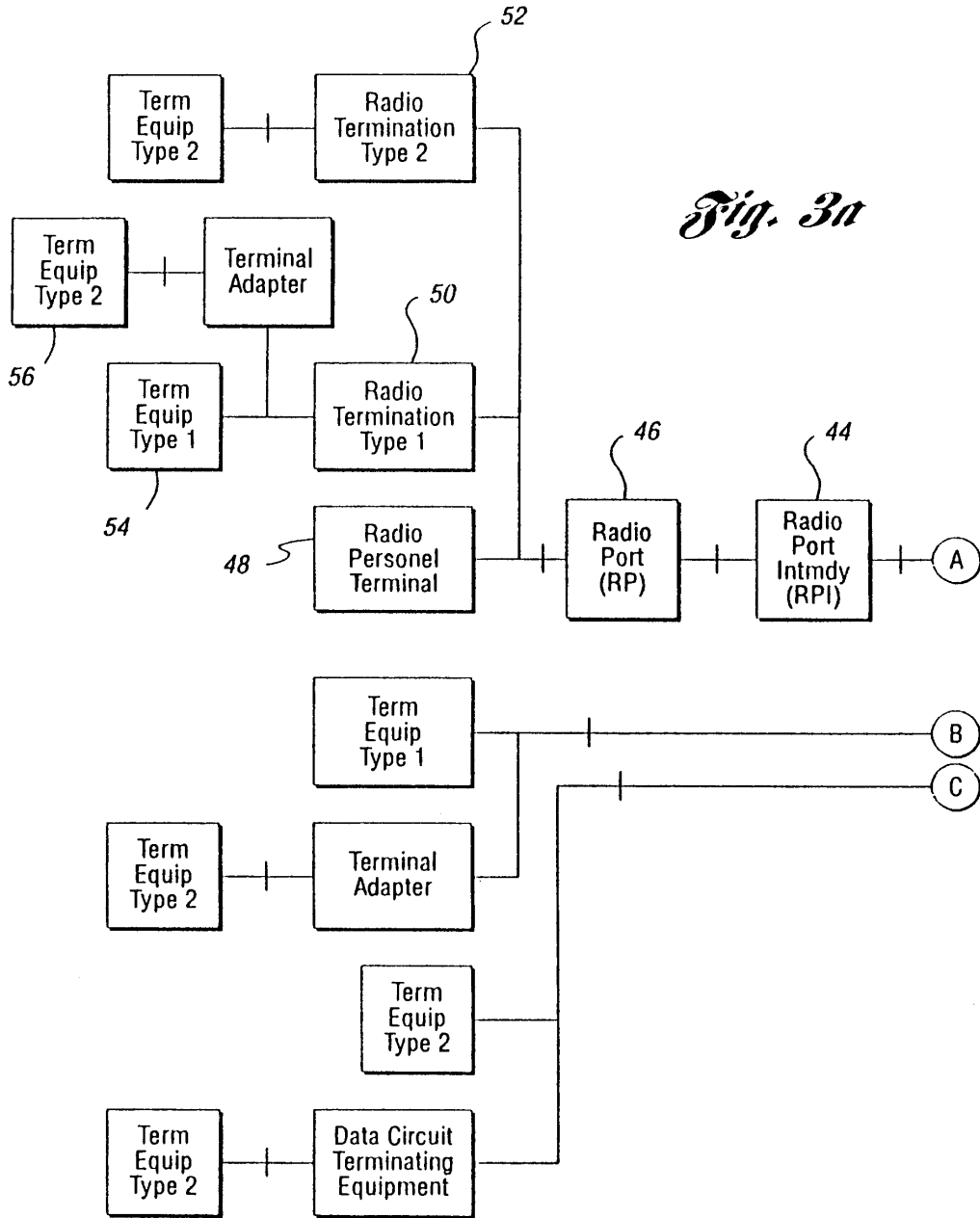
7. For use in cooperation with a wireless communication system, including a base station in electrical communication with at least one mobile unit within a corresponding coverage area, and a location databank operative to store real-time RF measurements for the base station, including its link budget, a system for updating the location databank, comprising:
- 5 a plurality of update centers at known fixed locations within the base station coverage area, each of the update centers including an electronically readable GeoPad encoded with the precalibrated location information for that center;
- an electronic reading device in electrical communication with the at least one mobile unit for decoding the encoded location information at each of the GeoPads;
- 10 a control unit in electrical communication with the base station;
- a Location Adjunct Processor (LAP) in electrical communication with the control unit and the location databank; and
- processing logic in electrical communication with the at least one mobile unit, the processing logic operative to obtain the RF measurements at each of the GeoPads and initiate a call to the LAP to transmit said measurements to the location databank along with the decoded location information.
- 15
8. For use in cooperation with a wireless communication system, including a base station in electrical communication with at least one mobile unit within a corresponding coverage area, and a location databank operative to store real-time RF measurements for the base station, including its link budget, a method for periodically updating the location databank, comprising:
- 20 providing a plurality of update centers at known fixed locations within the base station coverage area, each of the update centers including an electronically readable GeoPad encoded with the precalibrated location information for that center;
- providing an electronic reading device in electrical communication with the at least one mobile unit;
- 25 decoding the encoded location information at one of the GeoPads through the use of the electronic reading device;
- providing processing logic in electrical communication with the at least one mobile unit;
- providing a control unit in electrical communication with the base station;
- providing a Location Adjunct Processor (LAP) in electrical communication with the control unit;
- 30 providing a holding database in electrical communication with the LAP and the location databank; and
- making real-time RF measurements at one of the GeoPads and initiating a call to the LAP in cooperation with the processing logic to transmit the measurements along with the decoded location information to the holding database for temporary storage, whereby to provide said periodic updating of the location databank.
- 35
- 40
- 45
- 50
- 55

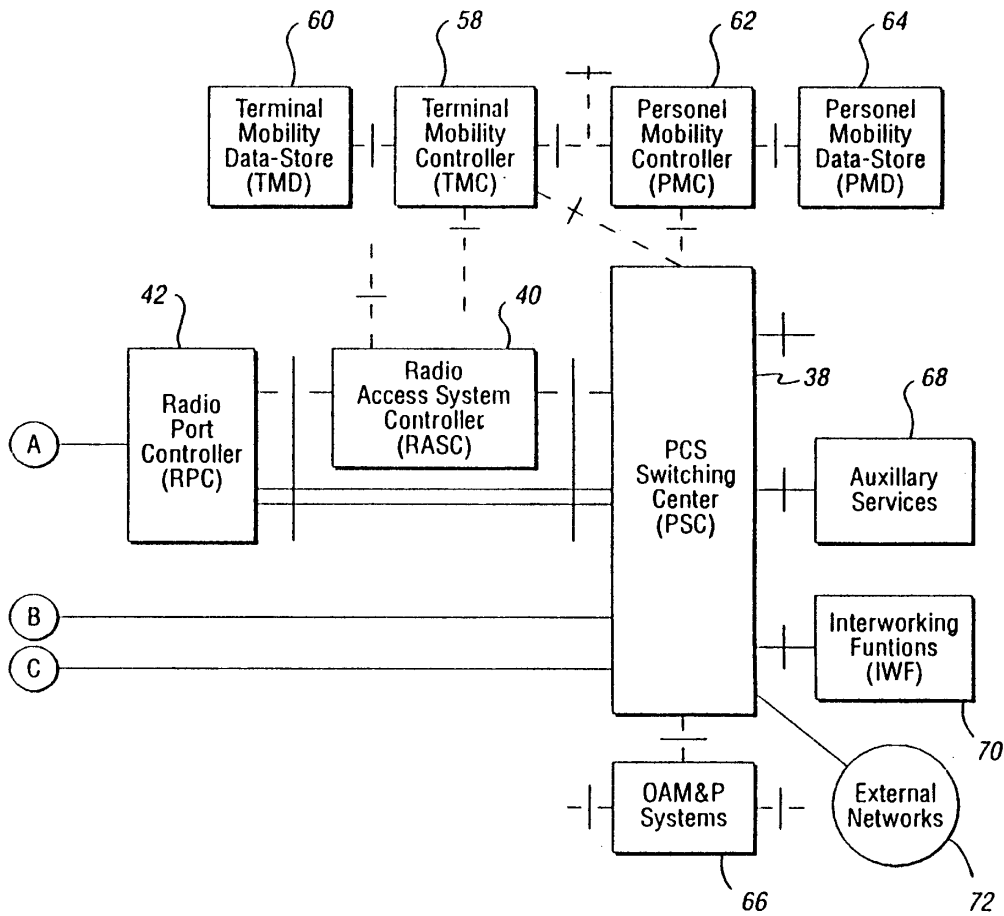


*Fig. 1 (PRIOR ART)*

*Fig. 2*  
*(PRIOR ART)*







*Fig. 3b*



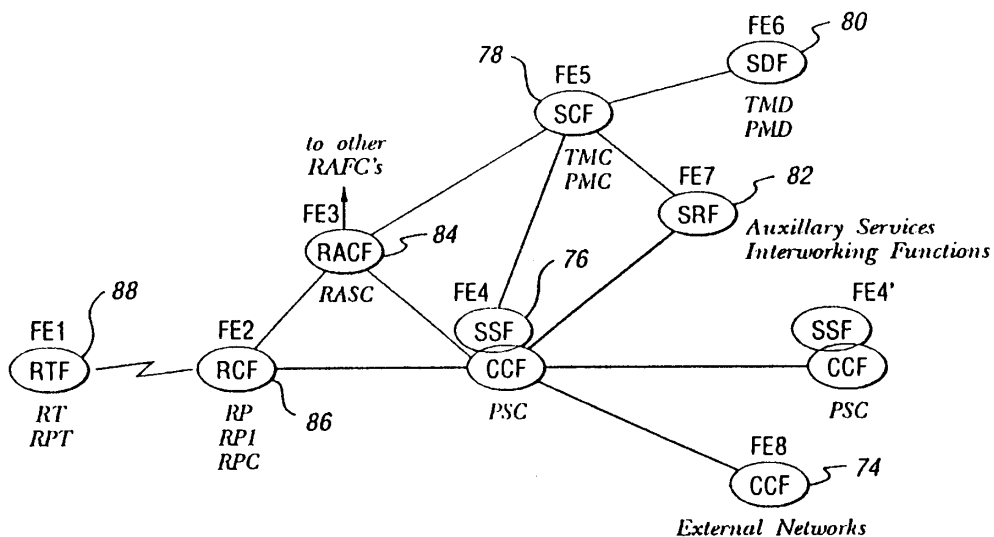


Fig. 4

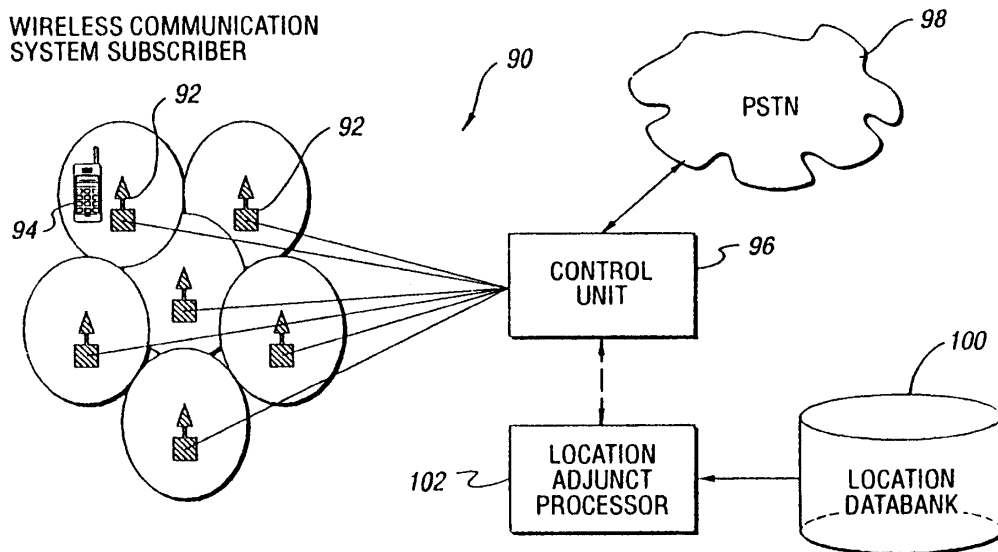
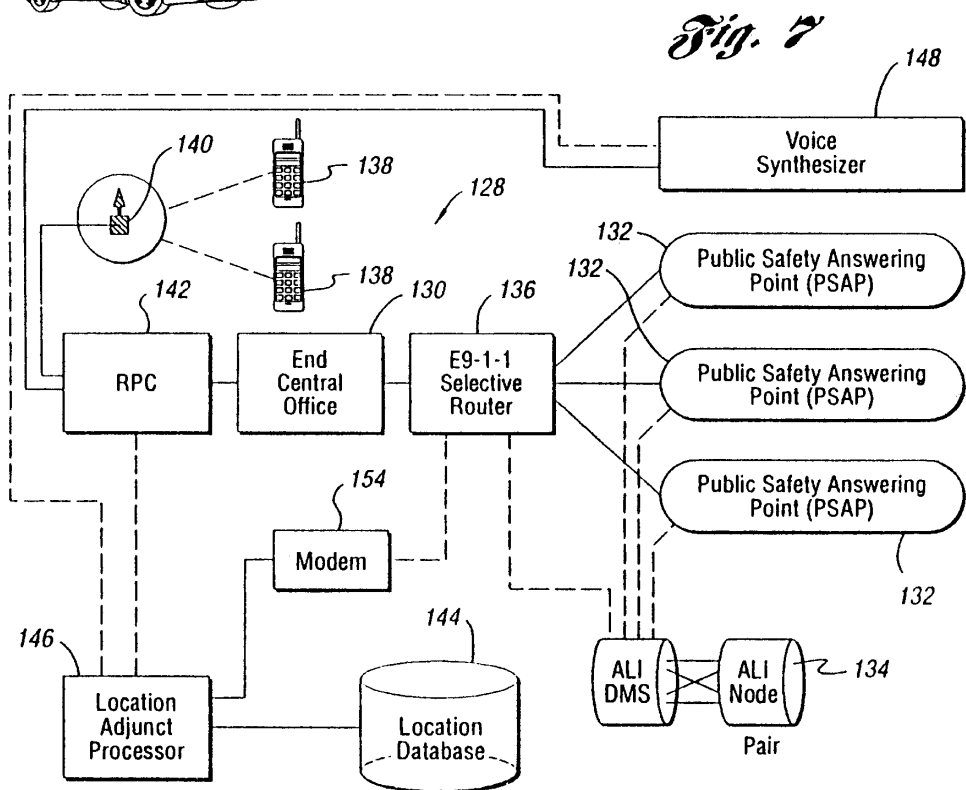
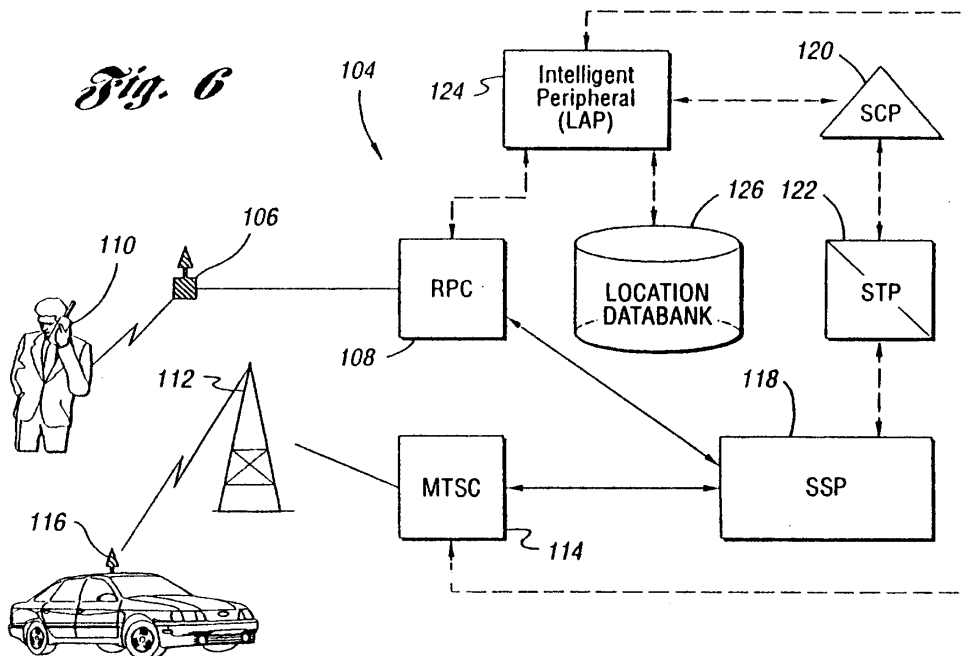
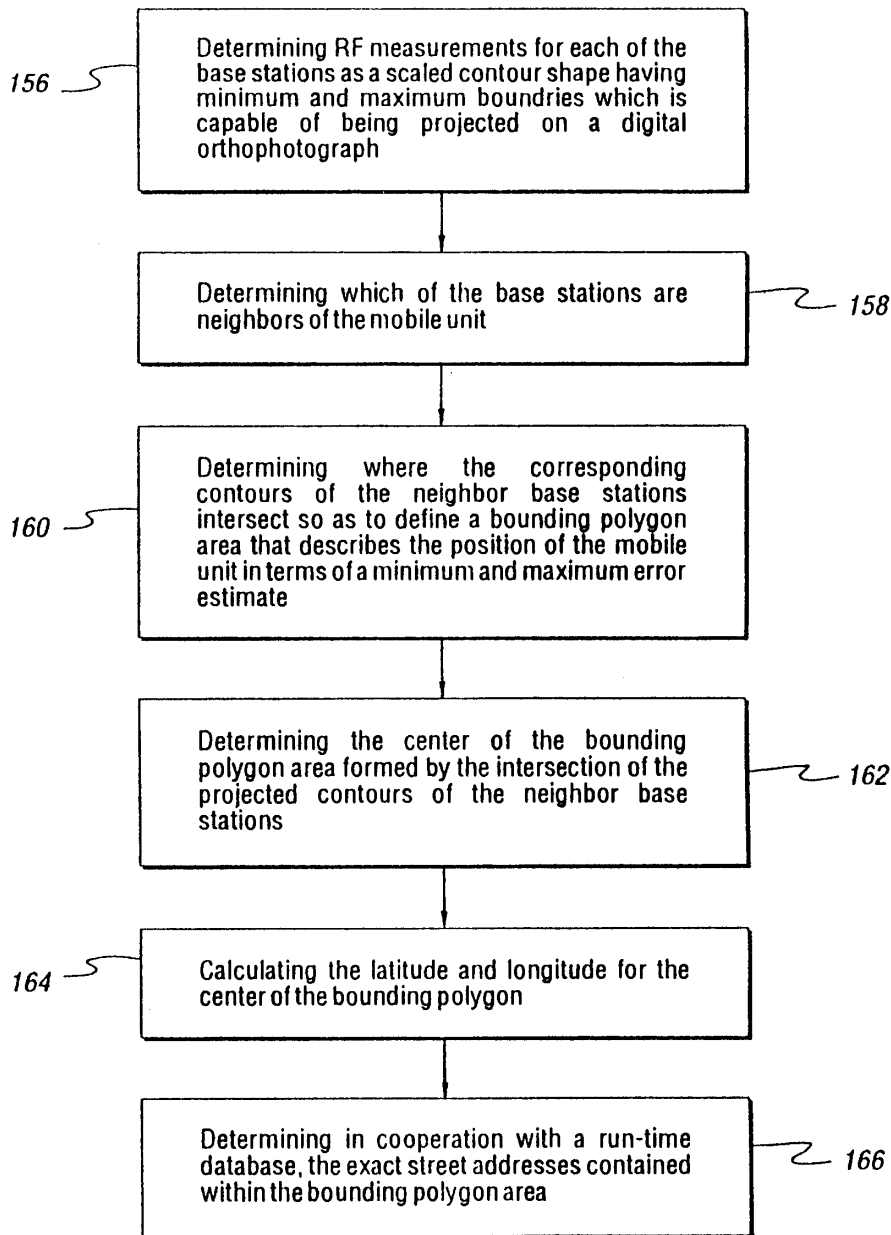
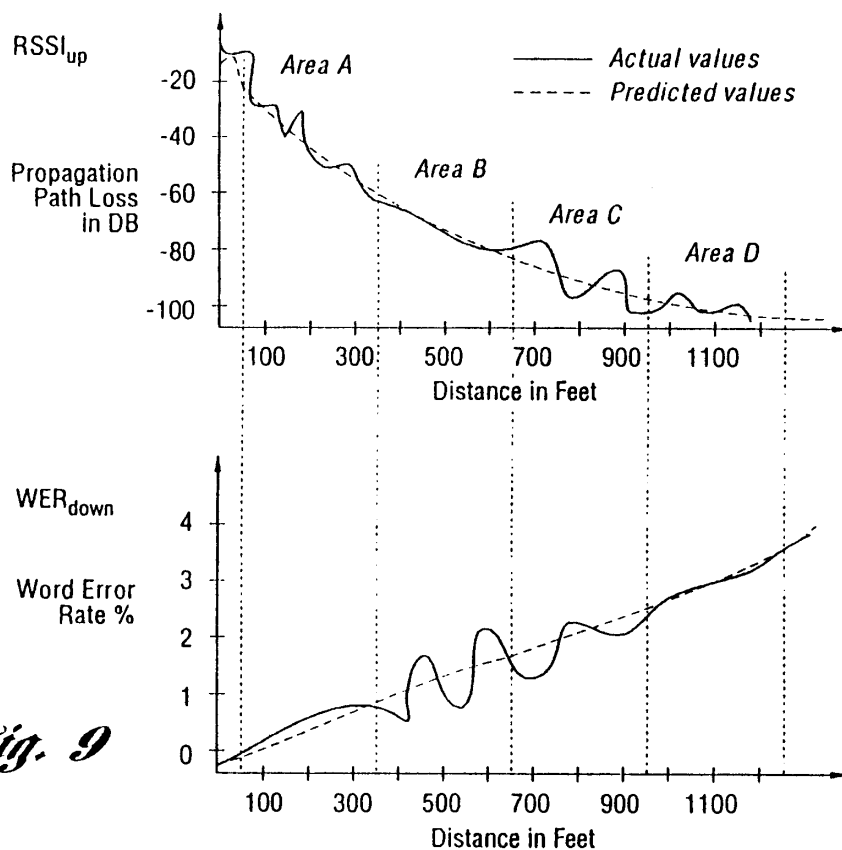


Fig. 5

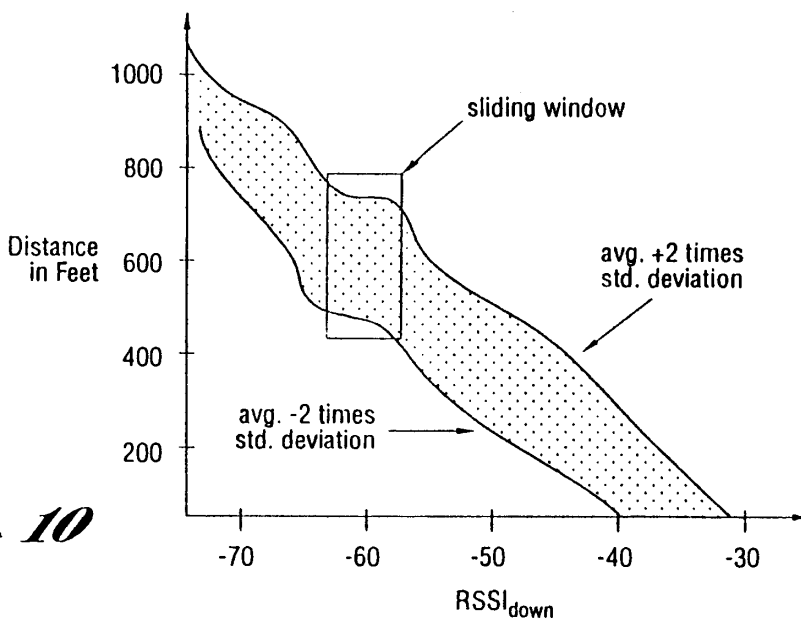




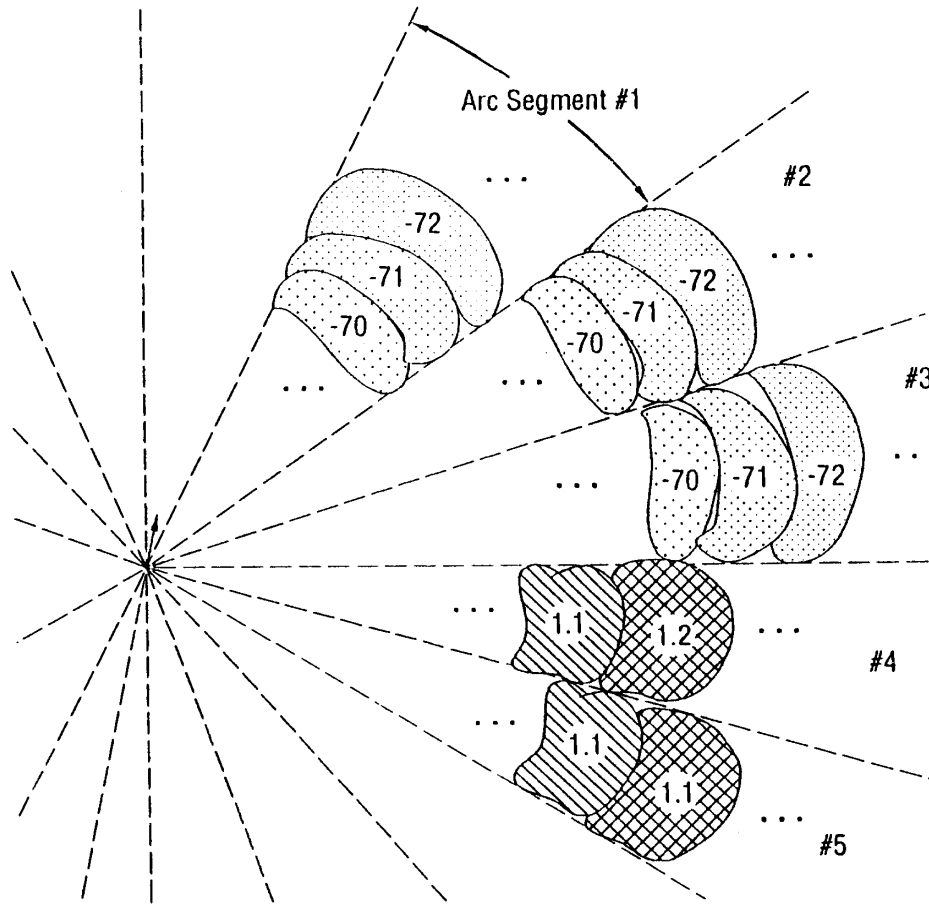
*Fig. 8*



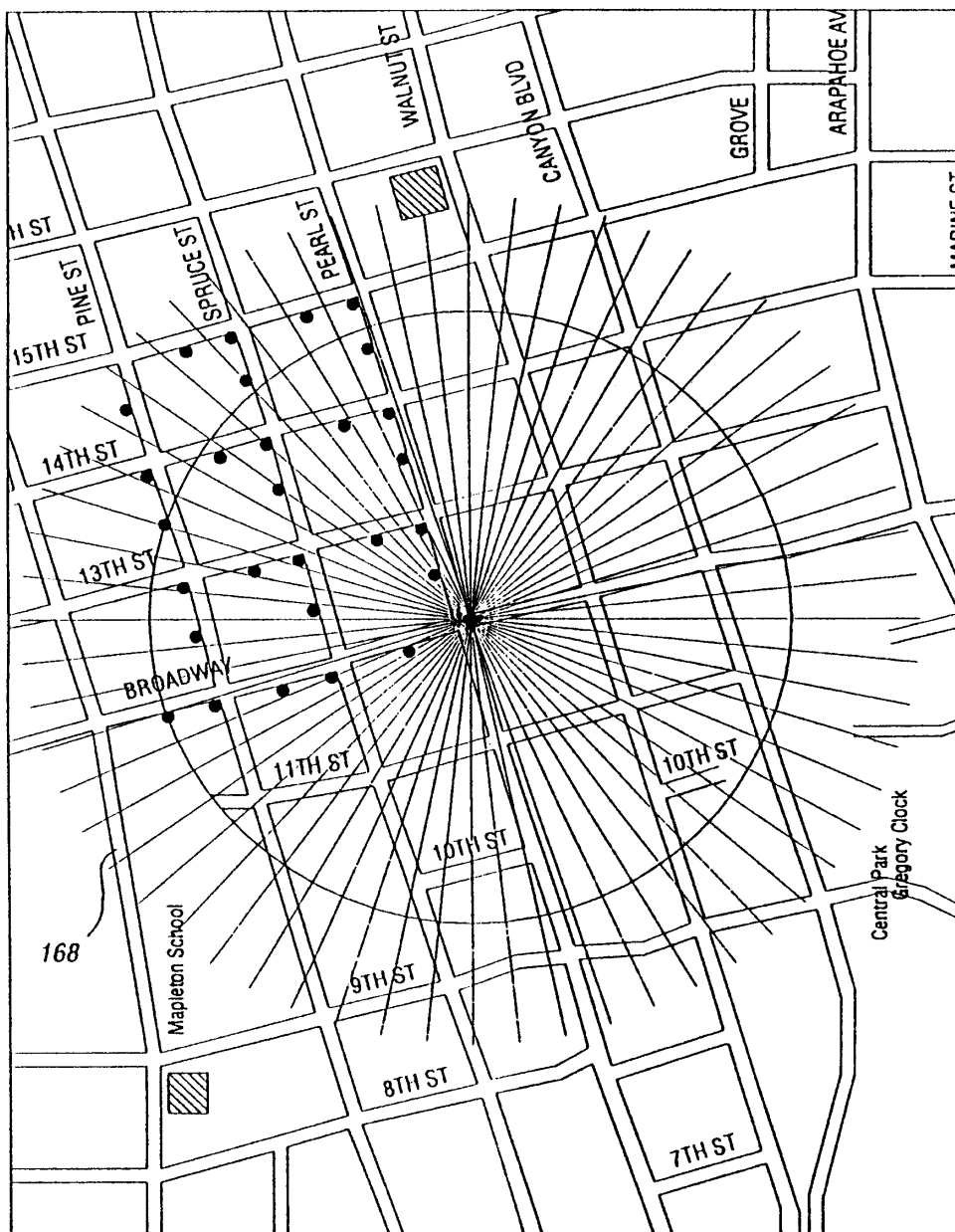
*Fig. 9*



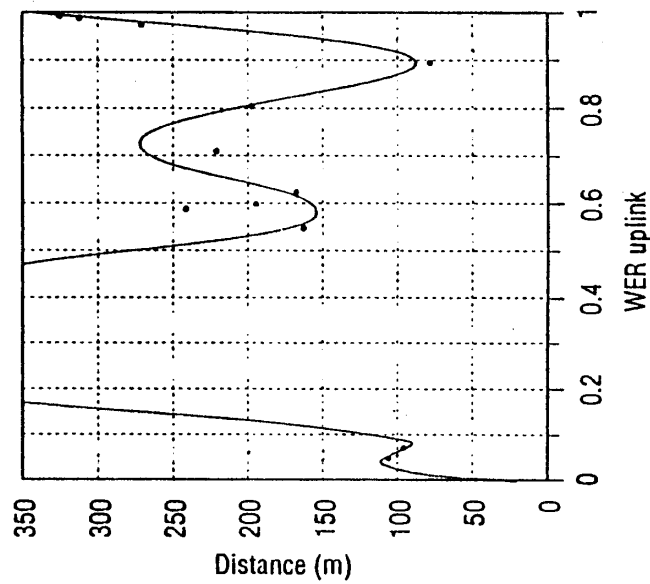
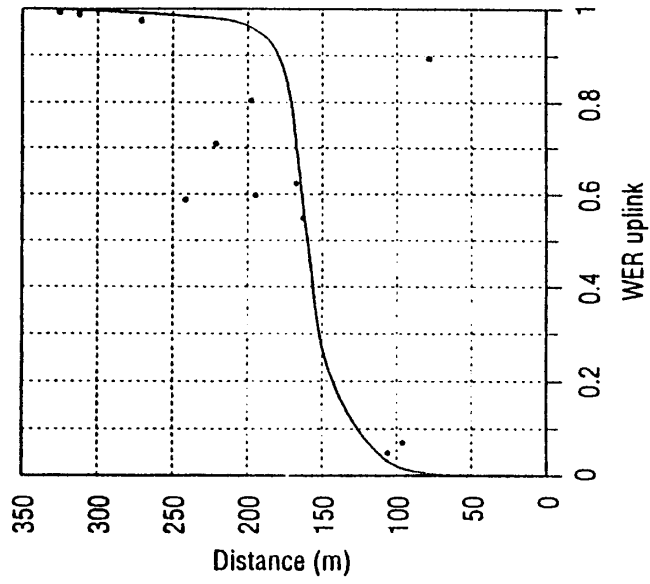
*Fig. 10*



*Fig. 11*



*Fig. 12*



*Fig. 13*

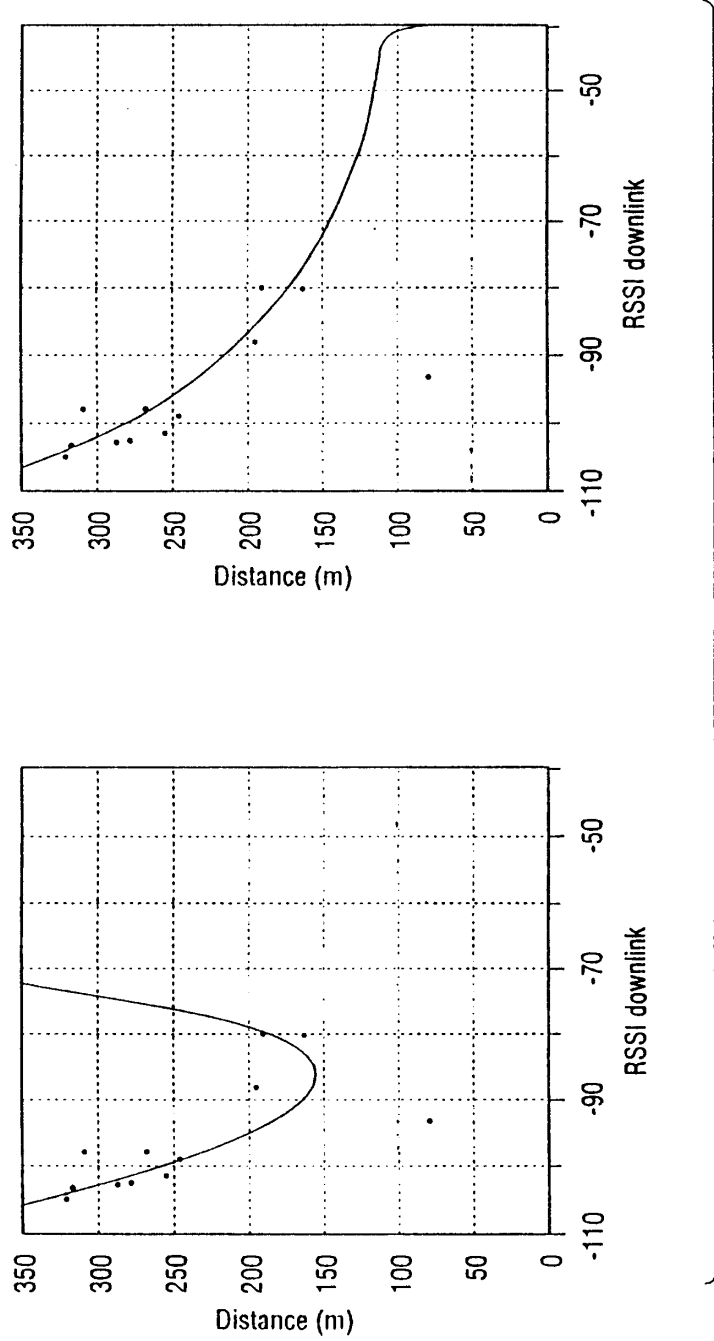


Fig. 14



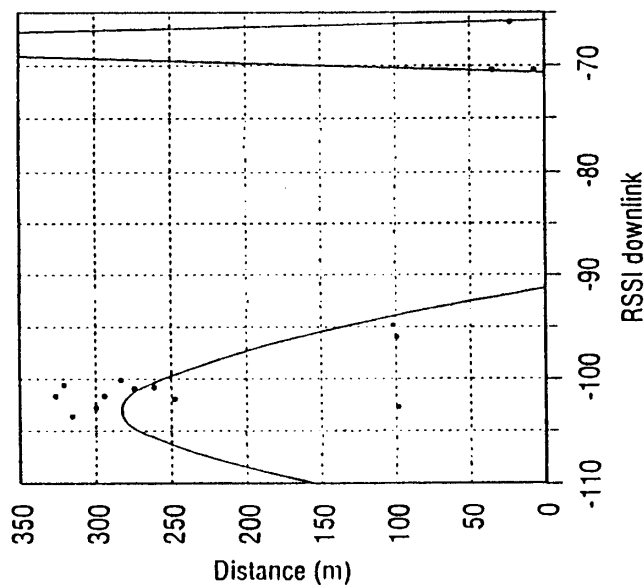
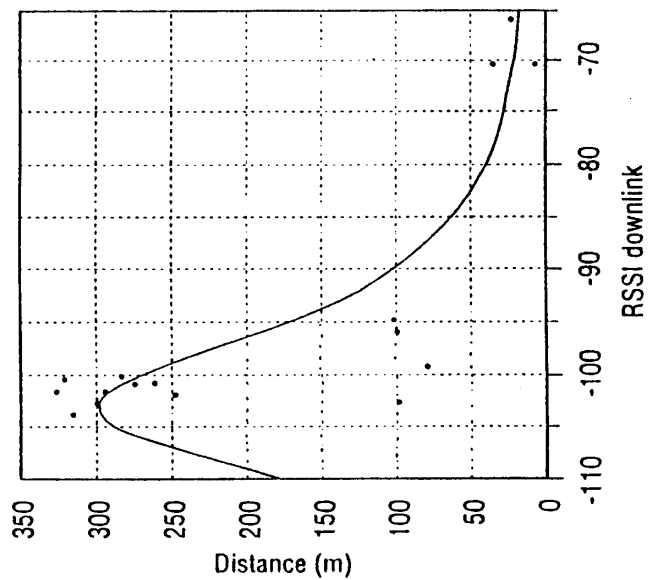
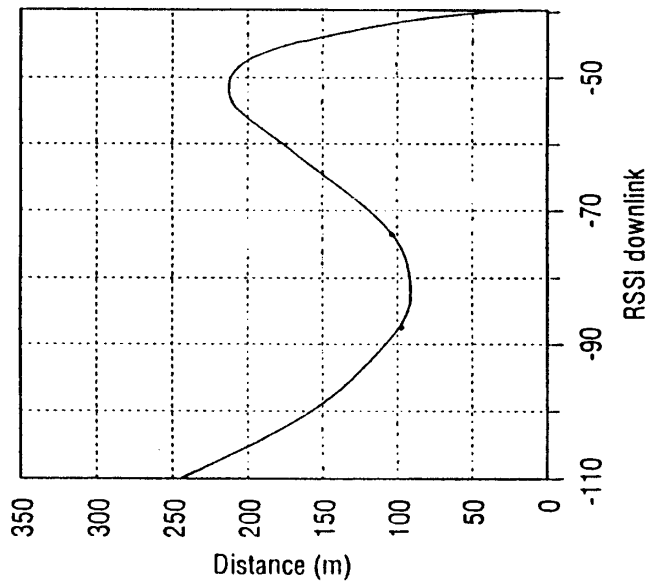
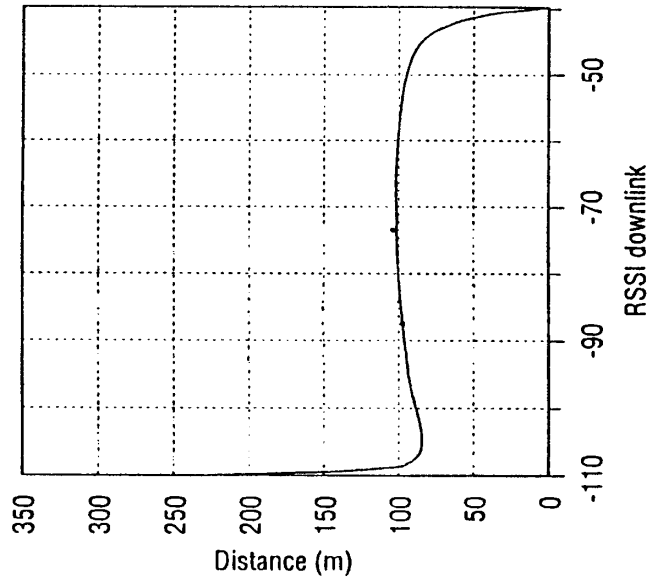
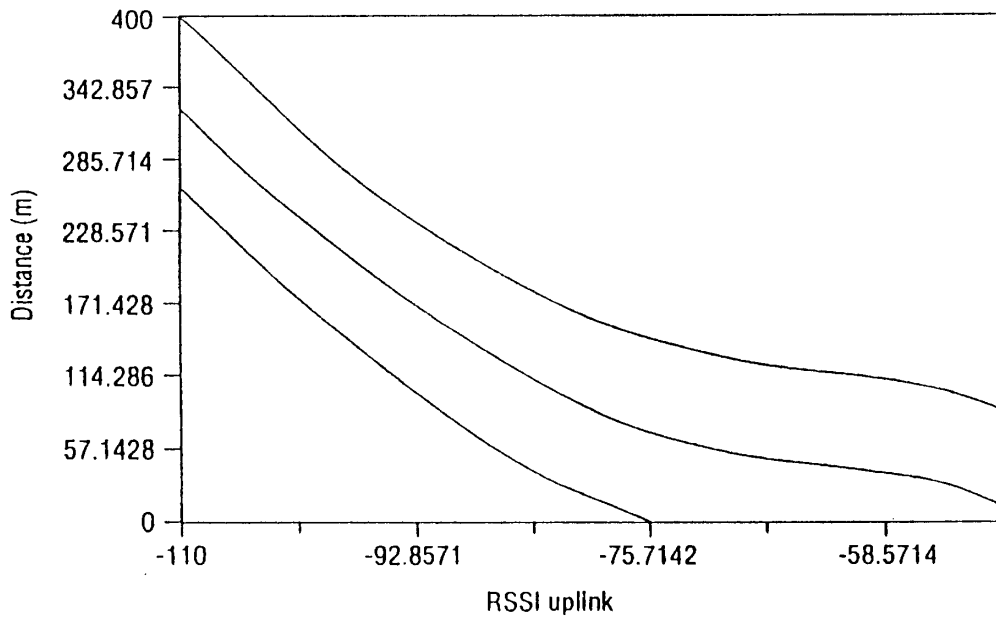


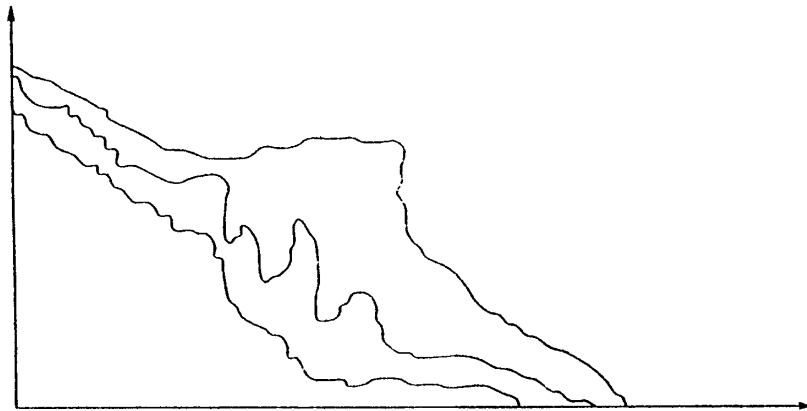
Fig. 15



*Fig. 16*

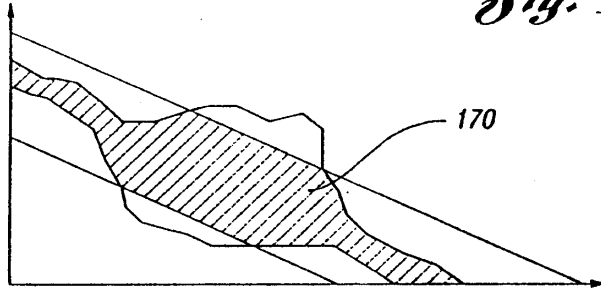


*Fig. 17*

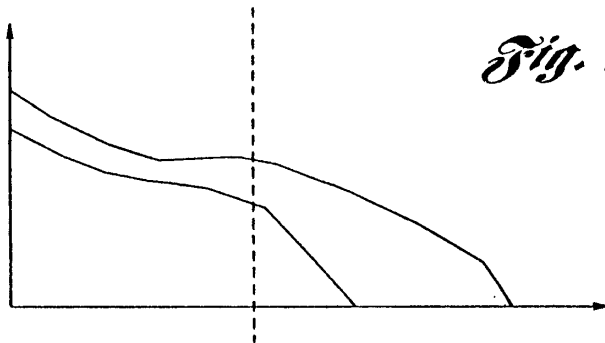


*Fig. 18*

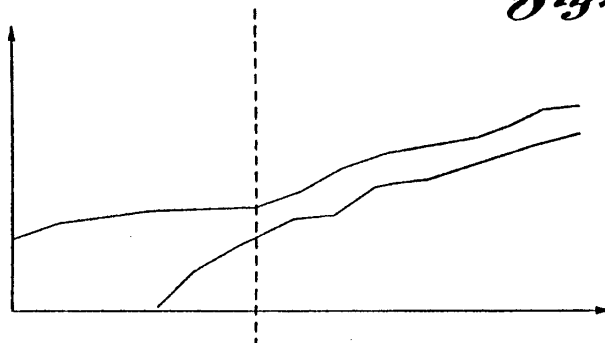
*Fig. 19*

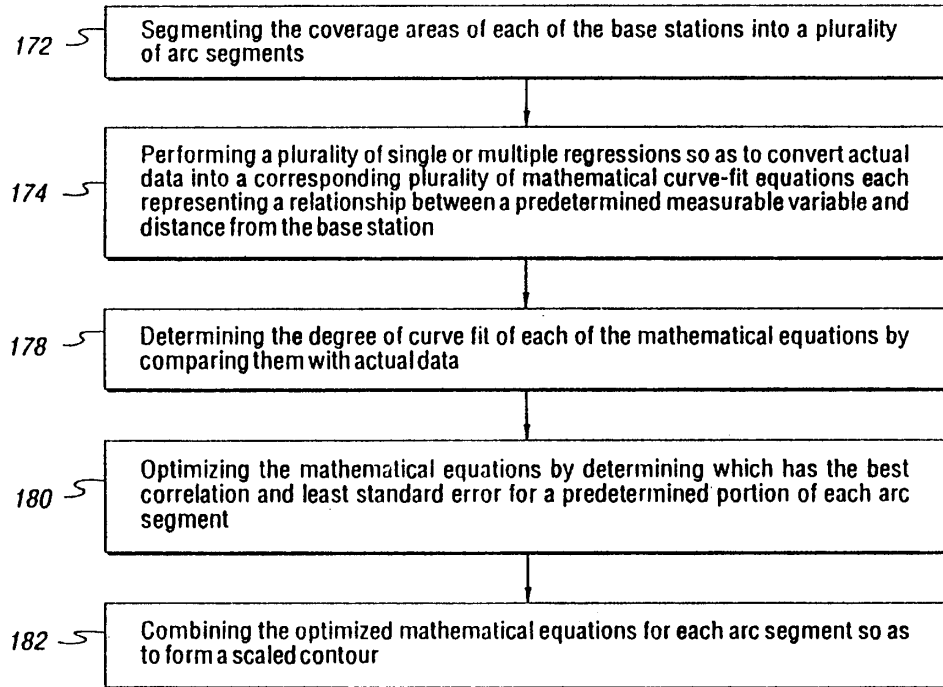


*Fig. 20*

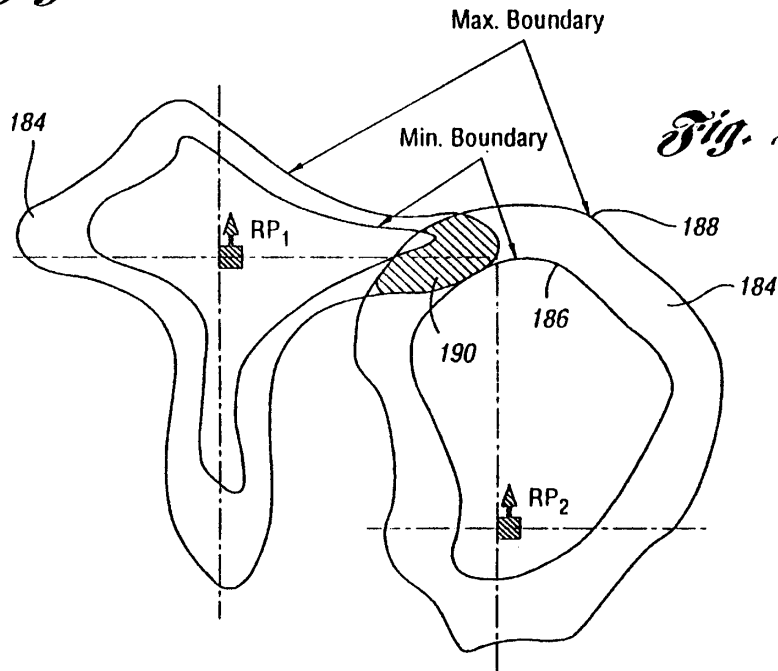


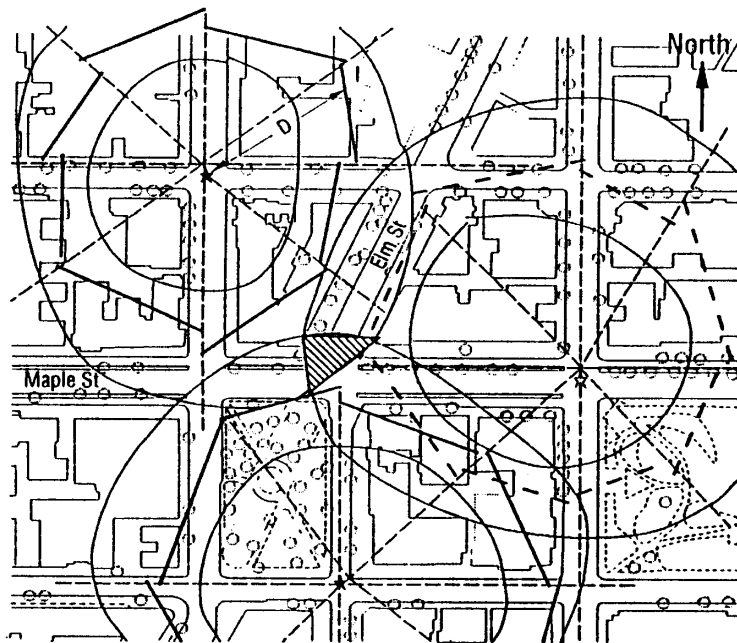
*Fig. 21*





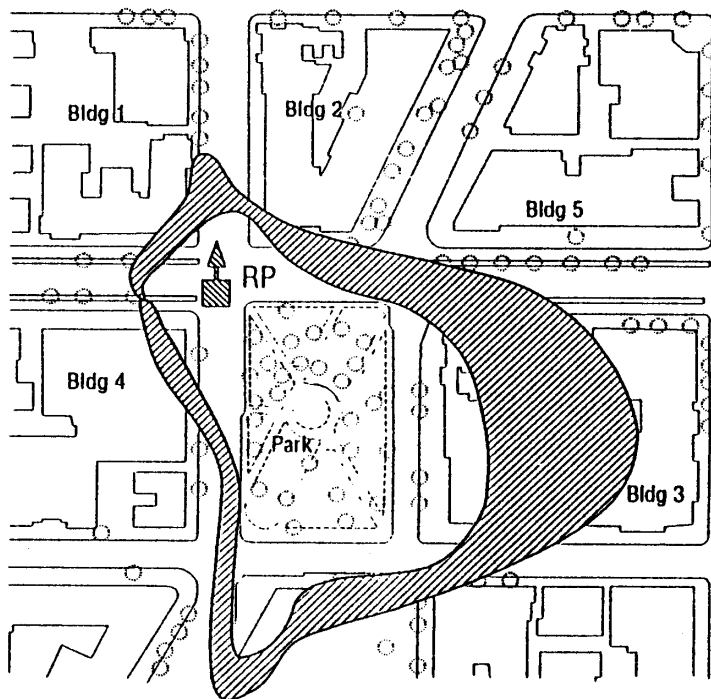
*Fig. 22*





*Fig. 24*

*Fig. 25*



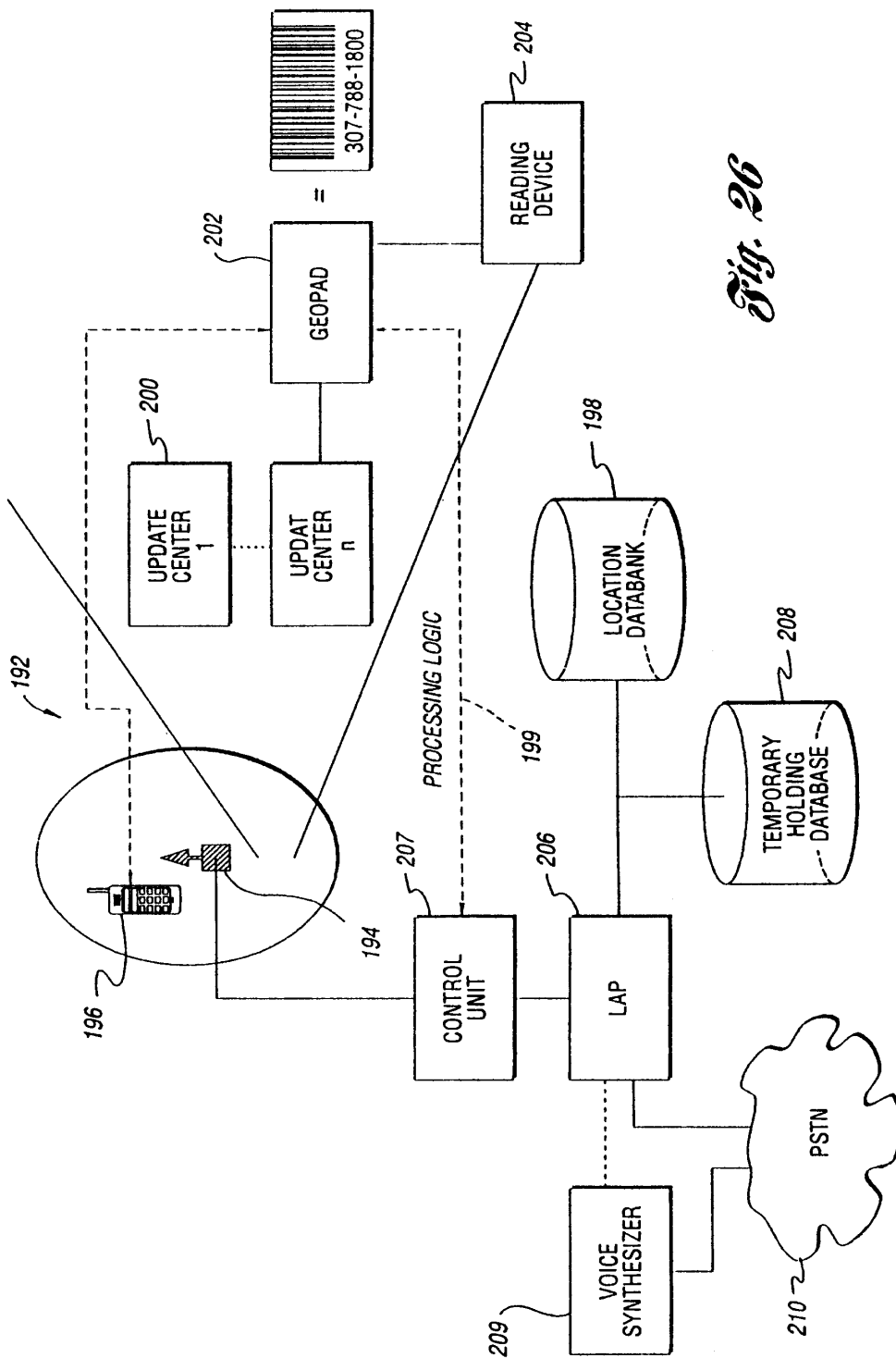
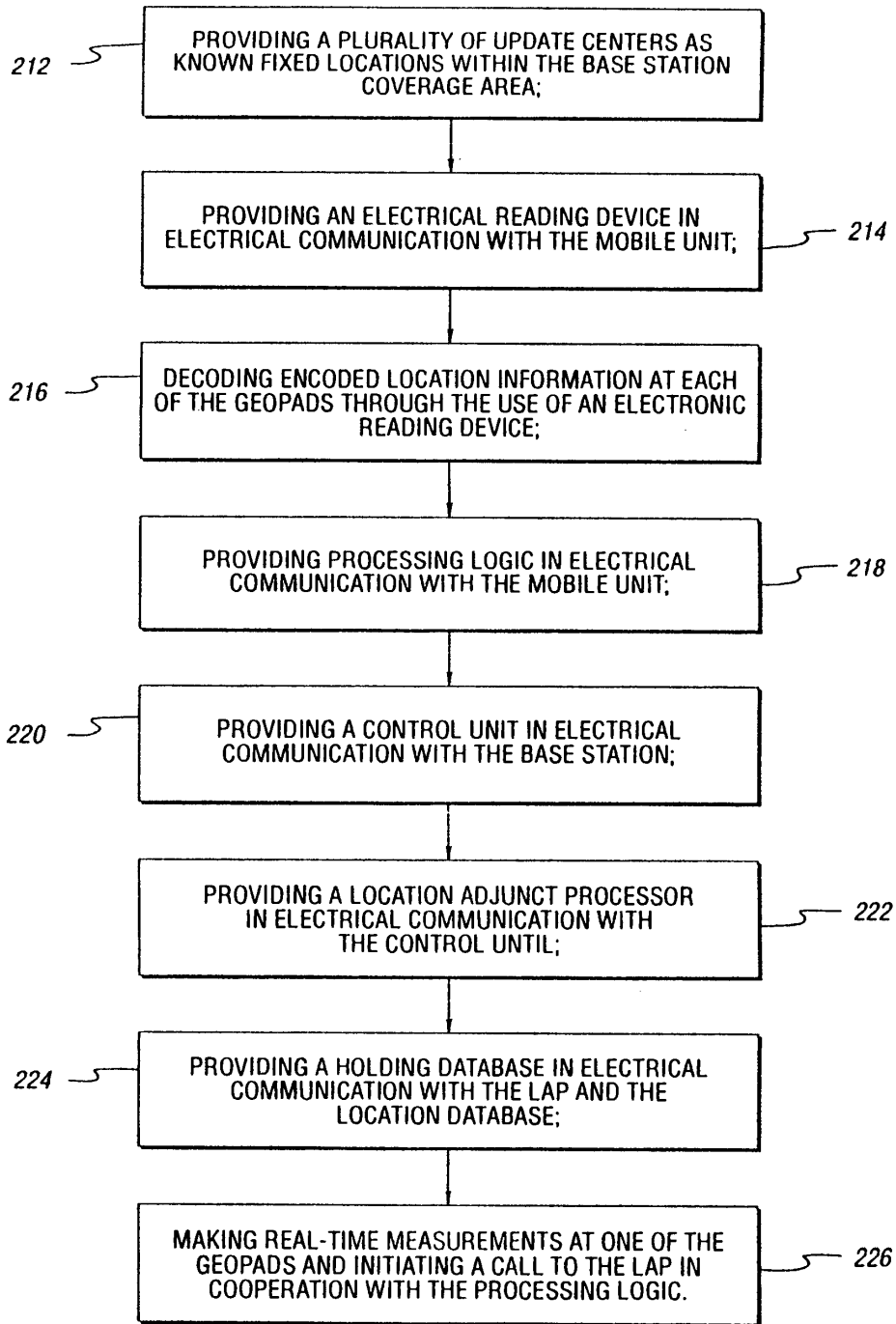


Fig. 26



*Fig. 27*





### Method for selecting route

#### Abstract

**PROBLEM TO BE SOLVED:** To provide a method for selecting a route capable of accurately searching a shortest travel time route by effectively utilizing both traffic congestion information and travel time information. **SOLUTION:** A searching data storage unit 201 specifies a searching range based on the inputs from a present position detector 101 and an input unit 104, reads and stores the map data of the corresponding searching range from a road network memory 103. A route searching unit 202 decides the search starting and ending points based on the inputs from the detector 101 and the unit 104 and selects the route from the starting point to the ending point based on the map data stored in the unit 201. A traffic congestion information correcting unit 203 corrects the travel time of the map data by estimating the estimated travel time for each traffic congestion zone of each link of the map data, based on the traffic congestion information obtained from a traffic information acquisition unit 102. A travel time information correcting unit 204 regulates the correction amount decided by the unit 203 based on the travel time information obtained from the unit 102.

JPH09287965A

Japan

Find Similar Art Similar

**Other languages:** Japanese

**Inventor:** Makoto Fushimi, Yoshiki Kamiyama, Takashi Yagyu, 芳賀 上山, 真伏晃, 嘉志 謙佳

**Worldwide applications**

1996

**Application JP10005696A events**

**1996-04-22** Application filed by Matsushita Electric Ind Co Ltd, 松下電器産業株式会社

**1996-04-22** Priority to JP10005696A

**1997-11-04** Publication of JPH09287965A

**2003-09-16** Application granted

**2003-09-16** Publication of JP3446922B2

**2016-04-22** Anticipated expiration

**2019-06-21** Application status is Expired - Fee Related

**Info:** Cited by (15), Legal events, Similar documents, Priority and Related Applications

**External links:** Espacenet, Global Dossier, Discuss

#### Claims (22)

Hide Dependent < translated from Japanese

[The claims]

1. A congestion information indicating a congestion level, congestion area positions on each link provided as claimed in claim 1) traffic information, based on the travel time information indicating a total transit time of the multiple links, the estimation of each link on the map data the travel time is calculated, a method for selecting a shortest travel time route, a first step of receiving the traffic information including the traffic jam information and the travel time information, received by said first step transportation based on the information, using a second step of calculating the estimated travel time for each link on the map data, the estimated travel time calculated in the second step, And a third step of calculating a shortest travel time route, the second step is based on said congestion information, a fourth calculating the estimated travel time or travel speed of the temporary each link on the map data steps and, based on the travel time information, characterized in that it comprises a fifth step of modifying the estimated travel time or travel speed of the temporary route selection method.
2. Wherein said fifth step is characterized by modified based the estimated travel time or travel speed of the temporary each link on the map data, the ratio of the provisional estimated travel time, Route selection method according to claim 1.
3. Wherein the fifth step is within the maximum correction a predetermined range, characterized by modifying the estimated travel time or travel speed of the temporary route selection method according to claim 1.
4. Wherein said fifth step is a section traffic congestion is present preferentially corrected, and correcting the portion which can not be corrected by congested absence interval, path according to claim 1 selection method.
5. A congestion information indicating a congestion level, congestion area position on each link is provided as wherein traffic information, based on the travel time information indicating a total transit time of the multiple links, the estimation of each link on the map data the travel time is calculated, a method for selecting a shortest travel time route, a first step of receiving the traffic information including the traffic jam information and the travel time information, received by said first step transportation based on the information, using a second step of calculating the estimated travel time for each link on the map data, the estimated travel time calculated in the second step, And a third step of calculating a shortest travel time route, distributing the when calculating the estimated travel time in the second step, the travel time obtained from the travel time information, with a weight to the congestion information characterized that, the path selecting method to.

(19) 日本国特許庁 (J P)

(12) 公開特許公報 (A)

(11) 特許出願公開番号

特開平9-287965

(43) 公開日 平成9年(1997)11月4日

| (51) Int.Cl. <sup>8</sup> | 識別記号   | 庁内整理番号 | F I           | 技術表示箇所 |
|---------------------------|--------|--------|---------------|--------|
| G 0 1 C                   | 21/00  |        | G 0 1 C 21/00 | G      |
| G 0 6 F                   | 17/00  |        | G 0 8 G 1/01  | E      |
|                           | 17/60  |        | 1/0969        |        |
| G 0 8 G                   | 1/01   |        | G 0 9 B 29/00 | F      |
|                           | 1/0969 |        | 29/10         | A      |

審査請求 未請求 請求項の数22 O L (全 42 頁) 最終頁に続く

(21) 出願番号 特願平8-100056

(22) 出願日 平成8年(1996)4月22日

(71) 出願人 000005821

松下電器産業株式会社  
大阪府門真市大字門真1006番地

(72) 発明者 伏見 真

大阪府門真市大字門真1006番地 松下電器  
産業株式会社内

(72) 発明者 柳生 岳志

大阪府門真市大字門真1006番地 松下電器  
産業株式会社内

(72) 発明者 上山 芳樹

大阪府門真市大字門真1006番地 松下電器  
産業株式会社内

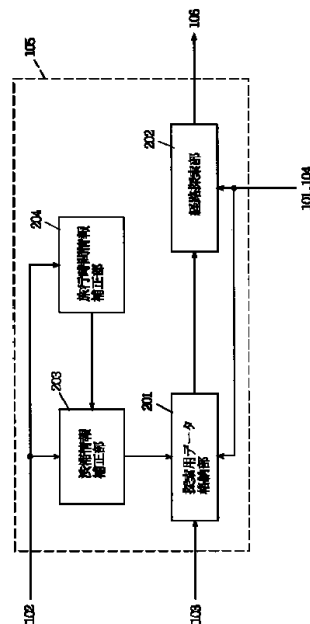
(74) 代理人 弁理士 小笠原 史朗

(54) 【発明の名称】 経路選出方法

(57) 【要約】

【課題】 渋滞情報と旅行時間情報の両方を有効に利用することにより、精度良く最短旅行時間経路を探索することのできる経路選出方法を提供する。

【解決手段】 探索用データ格納部201は、現在位置検出部101や入力部104からの入力に基づいて探索範囲を特定し、道路ネットワーク記憶部103から該当探索範囲の地図データを読み込んで格納する。経路探索部202は、現在位置検出部101や入力部104からの入力に基づいて探索開始点および探索終了点を決定し、探索用データ格納部201に格納された地図データに基づいて探索開始点から探索終了点までの経路を選出する。渋滞情報補正部203は、交通情報取得部102から入手した渋滞情報に基づき、地図データの各リンクの渋滞区間毎の推定旅行時間を推定し、地図データの旅行時間を補正する。旅行時間情報補正部204は、交通情報取得部102から入手した旅行時間情報に基づき、渋滞情報補正部203で決定される補正量を調整する。





### Updated map information distribution system and method, and recording medium stored with the method

#### Abstract

PROBLEM TO BE SOLVED: To provide the updated map information distribution system and method which facilitates a proper update request when obtaining map data and data relating a map by communicating with the outside and can obtain updated map information by communicating a small number of data, and to provide a recording medium where the method is recorded.

SOLUTION: A means 110 of a server system adds mesh update information to updated map information by meshes and stores them in a database 102 and a means 120 reupdates the information by meshes in the term of validity of the mesh update information; and a means 130 reads the mesh information which needs to be updated with the final current state confirmation information from a client system and a means 140 reads the updated map information by meshes out of updated request mesh information. A client system stores the updated map information and its update information as updated data and updates mesh information which should be updated, generates update-needed mesh information by comparing the update mesh information to be displayed with the update-needed mesh information, and judges the update state from the map information and updated map information to display the latest map information.

COPYRIGHT: (C)2000,JPO

JP2000298429A  
Japan

Find Patent Art Similar

**Other languages:** Japanese

**Inventor:** Kensaku Fujii, Kazuhiro Sugiyama, 和弘 杉山, 藤井 泰博

**Worldwide applications**

1999

**Application JP11107562A events**

1999-04-15 Application filed by Nippon Telegr & Teleph Corp <Ntt>, 日本電信電話株式会社

1999-04-15 Priority to JP10756299A

2000-10-24 Publication of JP2000298429A

2004-02-09 Application granted

2004-02-09 Publication of JP3495641B2

2019-04-15 Anticipated expiration

2019-06-21 Application status is Expired - Lifetime

**Info:** Cited by (9), Legal events, Similar documents, Priority and Related Applications

**External links:** Espacenet, Global Dossier, Discuss

#### Claims (4)

Hide Dependent < translated from Japanese

[The claims]

1. A server system with a 1. A update map information database, an update map information distribution system including a client system to receive updates map information by communication with the server system, the server system is updated and the map information is decomposed into data of each mesh, and updates the map data storage means for storing the update map information database by adding the mesh update information to the data, stored in the update map information database of the mesh update information based on the validity period, retrieves map data re-update means for re-updating the map information for each mesh, the update map information database based on the final current state confirmation information requested from the client system, from the mesh update information reads the update need mesh information that require update update A broadcast search means searches the updated map information database based on the update request mesh information requested from the client system, and a reading map data retrieval means map information updated in the corresponding mesh, the client system It includes a map data storage means for storing map information, updates the map information and the update data storage means for storing the update information, the update data storage means adds the update information to update the map information received from the server system in stores, retrieves and updates data storage means for updating the update required mesh information received from the server system, the update information of the mesh that may be displayed by searching the update data storage means, the update comparing the update required mesh information stored in the information and the update data storage unit, update And the update checking means for generating an update request mesh information request to the server system when required, the display request for the map information, the map data storage means is stored in the map information, and the update data storage reads map information stored in the means, the determining an update condition, updates the map information distribution system characterized by a display means for displaying the latest map information was
2. A server system wherein with the update map information database, an update map information distribution method between a client system that receives the update map information by communication with the server system, the server system updates been map information is decomposed into data of each mesh, and stored in the update map information database by adding the mesh update information to the data, based on the validity period of the mesh update information stored in the update map information database Te, re updating map information for each mesh, the searches the updated map information database based on the final current state confirmation information requested from the client system, the update required mesh information needed updates from the mesh update information read, update request meshes requested by the client system The searching update map information database, reads the map information updated in the corresponding mesh, the update map information distribution method, characterized in that on the basis of the distribution.
3. A server system with the update map information database, an update map information distribution method between a client system that receives the update map information by communication with the server system, the client system, wherein stores and adds the update information to update the map information received from the server system to the update data storage unit, update the update required mesh information received from the server system, is displayed by searching the update data storage means possible to acquire the update information of the mesh, the update information is compared with the update required

(19) 日本国特許庁 (J P)

(12) 公開特許公報 (A)

(11) 特許出願公開番号  
特開2000-298429  
(P2000-298429A)

(43) 公開日 平成12年10月24日 (2000. 10. 24)

| (51) Int.Cl. <sup>7</sup> | 識別記号  | F I           | テーマコード*(参考)       |
|---------------------------|-------|---------------|-------------------|
| G 0 9 B 29/00             |       | G 0 9 B 29/00 | A 2 C 0 3 2       |
| G 0 6 F 13/00             | 3 5 4 | G 0 6 F 13/00 | 3 5 4 D 5 B 0 5 0 |
|                           |       | 15/40         | 3 1 0 F 5 B 0 7 5 |
| G 0 6 T 1/00              |       | 15/401        | 3 7 0 C 5 B 0 8 9 |
|                           |       |               | 3 4 0 A           |

審査請求 未請求 請求項の数4 O L (全 12 頁) 最終頁に続く

(21) 出願番号 特願平11-107562  
(22) 出願日 平成11年4月15日 (1999. 4. 15)

(71) 出願人 00004226  
日本電信電話株式会社  
東京都千代田区大手町二丁目3番1号  
(72) 発明者 藤井 憲作  
東京都新宿区西新宿3丁目19番2号 日本  
電信電話株式会社内  
(72) 発明者 杉山 和弘  
東京都新宿区西新宿3丁目19番2号 日本  
電信電話株式会社内  
(74) 代理人 100062199  
弁理士 志賀 富士弥 (外1名)

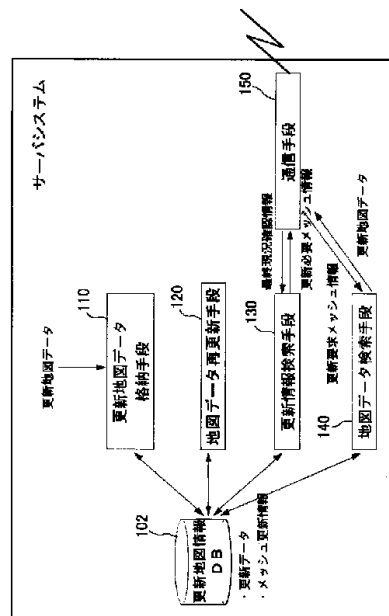
最終頁に続く

(54) 【発明の名称】 更新地図情報配信システム、方法、及びその方法を記録した記録媒体

(57) 【要約】

【課題】 外部との通信により、地図データや地図に関連するデータを取得し、データの最新化を図るには、更新要求の仕方や通信データ量に問題がある。

【解決手段】 サーバシステムの手段110はメッシュ毎の更新地図情報にメッシュ更新情報を付加してデータベース102に格納し、手段120はメッシュ更新情報の有効期間でメッシュ毎に再更新し、手段130はクライアントシステムからの最終現況確認情報で更新を必要とする更新必要メッシュ情報を読出し、手段140は更新要求メッシュ情報から更新されたメッシュ毎の地図情報を読出す。クライアントシステムは、更新地図情報とその更新情報を更新データとして記憶及び更新必要メッシュ情報を更新し、表示するメッシュの更新情報と更新必要メッシュ情報の比較で更新要求メッシュ情報を生成し、地図情報と更新地図情報から更新具合を判断して最新の地図情報を表示する。

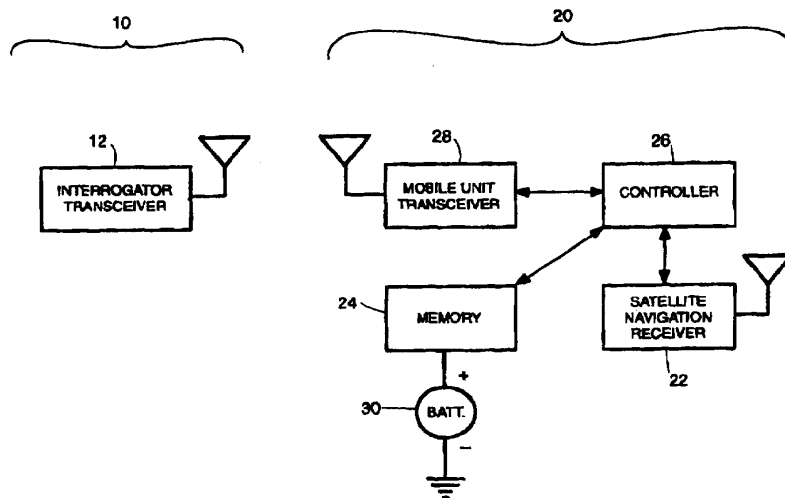




INTERNATIONAL APPLICATION PUBLISHED UNDER THE PATENT COOPERATION TREATY (PCT)

|   |                  |   |
|---|------------------|---|
| <p>(51) International Patent Classification <sup>6</sup> :<br/><b>G01S 5/14</b></p>   | <p><b>A2</b></p> | <p>(11) International Publication Number: <b>WO 97/24626</b><br/>(43) International Publication Date: 10 July 1997 (10.07.97)</p>   |
| <p>(21) International Application Number: PCT/US97/00195<br/>(22) International Filing Date: 2 January 1997 (02.01.97)<br/>(30) Priority Data:<br/>08/581,937 2 January 1996 (02.01.96) US<br/>(71) Applicant: MICRON COMMUNICATIONS, INC. [US/US];<br/>8000 South Federal Way, Boise, ID 83707 (US).<br/>(72) Inventors: WOOD, Clifton, W., Jr.; 3567 E. Boise Avenue,<br/>Boise, ID 83706 (US). TUTTLE, John, R.; 798 E.<br/>Pennsylvania Drive, Boise, ID 83706 (US).<br/>(74) Agent: VIKSNINS, Ann, S.; Schwegman, Lundberg, Woessner<br/>&amp; Kluth, P.O. Box 2938, Minneapolis, MN 55402 (US).</p> |                  | <p>(81) Designated States: AL, AM, AT, AU, AZ, BA, BB, BG, BR, BY, CA, CH, CN, CU, CZ, DE, DK, EE, ES, FI, GB, GE, HU, IL, IS, JP, KE, KG, KP, KR, KZ, LC, LK, LR, LS, LT, LU, LV, MD, MG, MK, MN, MW, MX, NO, NZ, PL, PT, RO, RU, SD, SE, SG, SI, SK, TJ, TM, TR, TT, UA, UG, UZ, VN, ARIPO patent (KE, LS, MW, SD, SZ, UG), Eurasian patent (AM, AZ, BY, KG, KZ, MD, RU, TJ, TM), European patent (AT, BE, CH, DE, DK, ES, FI, FR, GB, GR, IE, IT, LU, MC, NL, PT, SE), OAPI patent (BF, BJ, CF, CG, CI, CM, GA, GN, ML, MR, NE, SN, TD, TG).</p> <p><b>Published</b><br/><i>Without international search report and to be republished upon receipt of that report.</i></p> |

(54) Title: ITINERARY MONITORING SYSTEM



(57) Abstract

An itinerary monitoring system is described for use with a mobile object which uses a satellite navigation receiver, a memory which stores a series of itinerary data points, such as geographic location, and radio transceivers. The itinerary monitoring system includes a mobile unit carried by a mobile object which determines the geographic location of the mobile object over a time period using satellite navigation and stores the locations in memory. Additional information can be stored in the memory. The mobile unit includes a transceiver for two-way communication with a base transceiver to retrieve data stored in the memory.

**FOR THE PURPOSES OF INFORMATION ONLY**

Codes used to identify States party to the PCT on the front pages of pamphlets publishing international applications under the PCT.

|    |                          |    |  |    |                          |
|----|--------------------------|----|--|----|--------------------------|
| AM | Armenia                  | GB | United Kingdom                           | MW | Malawi                   |
| AT | Austria                  | GE | Georgia                                  | MX | Mexico                   |
| AU | Australia                | GN | Guinea                                   | NE | Niger                    |
| BB | Barbados                 | GR | Greece                                   | NL | Netherlands              |
| BE | Belgium                  | HU | Hungary                                  | NO | Norway                   |
| BF | Burkina Faso             | IE | Ireland                                  | NZ | New Zealand              |
| BG | Bulgaria                 | IT | Italy                                    | PL | Poland                   |
| BJ | Benin                    | JP | Japan                                    | PT | Portugal                 |
| BR | Brazil                   | KE | Kenya                                    | RO | Romania                  |
| BY | Belarus                  | KG | Kyrgyzstan                               | RU | Russian Federation       |
| CA | Canada                   | KP | Democratic People's Republic<br>of Korea | SD | Sudan                    |
| CF | Central African Republic | KR | Republic of Korea                        | SE | Sweden                   |
| CG | Congo                    | KZ | Kazakhstan                               | SG | Singapore                |
| CH | Switzerland              | LI | Liechtenstein                            | SI | Slovenia                 |
| CI | Côte d'Ivoire            | LK | Sri Lanka                                | SK | Slovakia                 |
| CM | Cameroon                 | LR | Liberia                                  | SN | Senegal                  |
| CN | China                    | LT | Lithuania                                | SZ | Swaziland                |
| CS | Czechoslovakia           | LU | Luxembourg                               | TD | Chad                     |
| CZ | Czech Republic           | LV | Latvia                                   | TG | Togo                     |
| DE | Germany                  | MC | Monaco                                   | TJ | Tajikistan               |
| DK | Denmark                  | MD | Republic of Moldova                      | TT | Trinidad and Tobago      |
| EE | Estonia                  | MG | Madagascar                               | UA | Ukraine                  |
| ES | Spain                    | ML | Mali                                     | UG | Uganda                   |
| FI | Finland                  | MN | Mongolia                                 | US | United States of America |
| FR | France                   | MR | Mauritania                               | UZ | Uzbekistan               |
| GA | Gabon                    |    |  | VN | Viet Nam                 |

## ITINERARY MONITORING SYSTEM

## 5 FIELD OF THE INVENTION

The invention relates to monitoring systems by which a base station monitors the location of one or more vehicles or other mobile objects by means of a conventional satellite navigation system.

## 10 BACKGROUND OF THE INVENTION

Many business activities involve a fleet of vehicles or other movable assets traveling to a number of destinations under the management of a central headquarters or base station. Examples include fleets of delivery trucks and railroad trains. Management and dispatching personnel at the base station  
15 generally desire the capability to monitor the itinerary actually traveled by each mobile unit. Such monitoring capability would permit managers and dispatchers to confirm whether the mobile unit deviated from a prescribed itinerary, or whether the driver violated regulations regarding speed limits or required periods of rest.

20 Various systems have been used to monitor fleets of mobile units by means of the U.S. Government operated G.P.S., Navstar, Argos, and Loran satellite navigation systems. Examples are described in U.S. Patent 5,119,102 to Barnard; and U.S. Patent 5,223,844 issued 6/29/93 to Mansell et al.

25 However, conventional systems by which a base station monitors the itineraries of one or more mobile units generally require the mobile units to remain in continuous or frequent radio communication with the base station. Such systems cannot monitor the itinerary of a mobile unit which travels out of communication range of the base station. Even systems which communicate via public cellular telephone networks cannot function when a mobile unit travels to  
30 a rural location lacking cellular telephone service.

**SUBSTITUTE SHEET (RULE 26)**

Therefore, a need exists for a system which monitors the itinerary of a mobile unit even when the mobile unit does not communicate with the base station during all or a portion of its travels.

A similar need exists for tracking stolen goods by law enforcement personnel. As described in U.S. Patent 4,908,629 issued 3/13/90 to Apsell et al., systems have been developed for locating a stolen automobile in which a police transmitter commands a transceiver hidden in the stolen automobile to begin transmitting a radio beacon so that it can be located using direction finding receivers. However, it would be desirable if the stolen automobile could transmit its geographical coordinates instead of a mere beacon. It would be even more desirable if the stolen automobile could store a history of all locations it has traversed (i.e., its itinerary) to help the police find the thieves and their accomplices. The same need exists for tracking any other type of valuable, movable asset.

15

#### SUMMARY OF THE INVENTION

The invention is a method and apparatus for a base station or interrogator station to monitor the itinerary of one or more vehicles or other movable assets. Each vehicle or other movable object includes a satellite navigation receiver with circuitry for computing the geographic position of the object, and a memory for storing a history of positions computed at a number of different times during the itinerary of the object. Each movable object further includes a radio transceiver which receives commands from the base station and which downloads the stored position history to the base station in response to an interrogation command.

Advantageously, the invention permits the interrogator station to determine the itinerary of each movable object, including its itinerary during periods when the vehicle or object is not within radio communication range of the base station.

The interrogator station may be a dispatching center, warehouse, or shipping dock to which the vehicle or other movable object returns periodically.

**SUBSTITUTE SHEET (RULE 26)**



In that case, the interrogator station would only interrogate the object when it returns to the base station after completing its itinerary.

Alternatively, there may be a number of interrogator stations which the mobile object passes by, or stops at, during its itinerary. For example, a vehicle  
5 being monitored may stop at a number of different shipping docks, and each dock may include an interrogator station which downloads from the vehicle its itinerary since it left the last dock. As another example, the interrogator stations may be checkpoints positioned at intervals along a railway route or water way to monitor the travels of railroad cars or water vessels, respectively.

10 Unlike conventional systems in which a base station continuously tracks the position of a mobile unit, in the present invention there is no need for communication between the interrogator and the mobile unit while the mobile unit is away from the interrogator. This eliminates the need for either a large network of RF repeater transceivers or expensive communications over cellular  
15 telephone or satellite links.

Furthermore, because the interrogator and mobile unit only have to communicate over a short distance, neither the interrogator nor the mobile unit needs a large antenna or a high power RF transmitter as required in many conventional systems. In fact, the transmitter section of either the interrogator or  
20 the mobile unit can be a passive transmitter which derives all or most of its operating power from received RF signals, such a conventional modulated backscatter transmitter, which modulates a received RF signal and reflects it back to the sender. Eliminating the need for high transmitter power is especially important in applications in which the interrogator or the mobile unit must rely  
25 on battery power.

Such a modulated backscatter transmitter is preferred for a mobile unit which is being monitored surreptitiously (that is, without the knowledge of the operator or custodian of the mobile unit). Because such a transmitter only responds to received RF signals, it is difficult to detect by an RF detector (“RF  
30 sniffer”). It is further preferable that the mobile unit only transmits a radio

**SUBSTITUTE SHEET (RULE 26)**

signal in response to a command, received from an interrogator, which is specifically addressed to an identification code assigned to that mobile unit.

When used to track stolen goods, the interrogator station could be implemented in a police vehicle. Since the transceiver in the stolen object need  
5 not transmit any radio signals to the interrogator station until interrogated by the interrogator station, the thief likely would not discover the transceiver until after its location history already had been transmitted to the police.

#### BRIEF DESCRIPTION OF THE DRAWINGS

10 Figure 1 is a schematic block diagram of an itinerary monitoring system according to the invention.

#### DETAILED DESCRIPTION OF THE PREFERRED EMBODIMENT

The itinerary monitoring system includes one or more interrogator  
15 stations, each having an interrogator 10, and one or more mobile units, each having a mobile unit navigation system 20.

Each mobile unit can be a vehicle such as a delivery truck or railroad train. Alternatively, a mobile unit can be a valuable asset whose location should be monitored, such as a machine being transported. A mobile unit could even be  
20 a person whose travel pattern is to be monitored.

The interrogator station can be a single dispatching center, warehouse, or shipping dock to which the mobile unit returns from time to time. An interrogator 10 can monitor any number of mobile units. For example, the interrogator station may be a central warehouse of a shipping company, and the  
25 mobile units may be a large number of delivery trucks which pick up goods from the warehouse in the morning, travel to various customer destinations during the day, and return to the warehouse at night. As each truck returns to the warehouse, the interrogator 10 at the warehouse would interrogate the mobile unit navigation system 20 in the truck to determine the itinerary traveled by the  
30 truck since it left the warehouse.

**SUBSTITUTE SHEET (RULE 26)**

Because the interrogator 10 and the mobile unit 20 communicate by radio, there is no need to attach any cable or connector to the mobile unit when it arrives at the interrogator station. In fact, the interrogator transceiver can be implemented in a hand-held wand which an operator holds near the mobile unit while data is being downloaded from the mobile unit to the interrogator transceiver 12. This method of downloading data by radio transmission can be much faster than making a hard-wired connection. Additionally, it can be surreptitious, so that the operator of the mobile unit is unaware that the mobile unit is being monitored.

10 The monitoring system can include any number of interrogator stations, and the mobile unit can travel from one interrogator station to another interrogator station. It is not even necessary for the mobile unit to stop while it is downloading data to an interrogator station. For example, each interrogator station 10 can be located at a checkpoint which the mobile unit passes while  
15 traveling on its itinerary. Such a checkpoint would be especially useful for monitoring train movements along railways, or barge movements down a river. A number of checkpoints can be positioned at intervals along a railway, river route, or major highway, with a complete interrogator station 10 at each checkpoint. All the checkpoints can be linked to a single headquarters station by  
20 any conventional data communications link. Each checkpoint can forward to the headquarters station the itinerary data received by the checkpoint interrogator 10 when a mobile unit 20 travels by the checkpoint.

Each mobile unit navigation system 20 includes a conventional satellite navigation receiver 22 which computes the geographic position (typically, global  
25 latitude and longitude) of the mobile unit by receiving radio signals from a number of satellites. As is well known, the U.S. Government operates groups of navigation satellites known as G.P.S., Navstar, Argos, and Loran. Economical and compact G.P.S. (Global Positioning System) navigation receivers are readily available commercially from various suppliers such as Trimble and Rockwell.  
30 Such satellite receivers 22 typically compute the position of the receiver by well-

**SUBSTITUTE SHEET (RULE 26)**

known triangulation algorithms based on the differences in arrival times of signals received from three or more G.P.S. satellites.

Each mobile unit navigation system 20 also includes a memory circuit 24, such as a conventional random access memory integrated circuit (I.C.) chip, and a controller circuit 26, such as a conventional microprocessor I.C. chip. At regular intervals, the controller 26 sends a command signal to the navigation receiver 22 directing the receiver to compute its current geographic location based on satellite signals received by the receiver 22. The controller then stores the computed location data and current time in the memory 24. Consequently, the memory 24 accumulates a detailed history of the itinerary of the mobile unit 20.

A transceiver 28 within each mobile unit navigation system 20 performs 2-way radio communication between the mobile unit navigation system 20 and one or more interrogators 10, each of which also has a transceiver 12. Any conventional radio signal modulation scheme and communications protocol may be employed for exchanging commands and data between a mobile unit and a base station. At a minimum, the protocol should include a "download itinerary" command which the interrogator transceiver 12 can send to the mobile unit transceiver 28, in response to which the mobile unit transmits (downloads) to the interrogator all or a specified portion of the itinerary data stored in the memory 24.

In the prototyped preferred implementation, the respective transceivers 12 and 28 in the interrogator and the mobile unit communicate at the standard, unlicensed microwave frequency of 2.45 GHz using spread spectrum modulation to achieve a data transfer rate of 300 Kbits/second. A preferred communications protocol is described in commonly assigned U.S. Patent 5,365,551 to Snodgrass et al., the entire contents of which are hereby incorporated into the present patent specification. Communication at UHF radio frequencies, such as 915 MHz, is a suitable alternative.

In addition to storing the itinerary (geographic position at each point in time) data as just described, the memory 24 stores an identification code which

**SUBSTITUTE SHEET (RULE 26)**

unique identifies the mobile unit 20 to the interrogator 10. The identification code can be permanently stored in a non-volatile portion of the memory 24 during manufacture of the system. Alternatively, the identification code for each mobile unit 20 can be chosen by an interrogator 10 and transmitted to the mobile unit 20 for storage in its memory 24. Each mobile unit should transmit its identification code as part of any communications exchange with an interrogator. In the preferred embodiment, the identification code is a four byte (32-bit) binary number, permitting 4.3 billion unique identification codes. The preferred embodiment also includes the capability to append six additional bytes to the identification code to convey additional identifying information such as a 4-byte S.I.C. (Standard Industry Classification) code and a 2-byte specialty code.

Unlike conventional systems in which a base station continuously tracks the position of a mobile unit, in the present invention there is no need for communication between the interrogator and the mobile unit while the mobile unit is away from the interrogator. This eliminates the need for either a large network of RF repeater transceivers or expensive communications over cellular telephone or satellite links.

Furthermore, because the interrogator and mobile unit only have to communicate over a short distance, neither the interrogator transceiver 12 nor the mobile unit transceiver 28 needs a large antenna or a high power RF transmitter as required in many conventional systems. Transmitter power in the milliWatt range is preferred. In fact, the transmitter section of either the interrogator transceiver 12 or the mobile unit transceiver 28 can be a passive transmitter which derives all or most of its operating power from received RF signals, such as a conventional modulated backscatter transmitter, which modulates a received RF signal and reflects it back to the sender. An example of a modulated backscatter transmitter is described in U.S. Patent 4,075,632 issued 2/21/78 to Baldwin et al.

Eliminating the need for high transmitter power is especially important in applications in which the interrogator 10 or the mobile unit 20 must rely on battery power. One such application is a hand-held interrogator as described

**SUBSTITUTE SHEET (RULE 26)**

earlier. Another battery-powered application is when a mobile unit has no power source of its own, such as when the invention is used to monitor a valuable object or a person. Yet another application for battery power is when the mobile unit navigation system 20 is hidden within a mobile unit, such as a theft protection system installed at a hidden location within an automobile, or a system for covertly or surreptitiously monitoring the itinerary of a delivery truck without the truck driver's knowledge. To prevent detection of the hidden navigation system 20, it is preferable for the navigation system to rely entirely on its internal battery 30 instead of connecting it to the power supply of the mobile unit.

In situations in which a mobile unit is being monitored covertly or surreptitiously (that is, without the knowledge of the operator or custodian of the mobile unit), it is preferable that the mobile unit transceiver 28 never initiates a radio communication, but only transmits a radio signal in response to a command, received from an interrogator, which is specifically addressed to that mobile unit's identification code. Consequently, the number of transmissions from the mobile unit transceiver 28 is minimized, and the identification code makes it difficult for an unauthorized person to initiate a transmission, so that the presence of the mobile unit system 20 will be hard for an unauthorized person to detect. In such covert situations, it also is preferable for the transmitter portion of the mobile unit transceiver 28 to be a modulated backscatter passive transmitter as described earlier. Because such a transmitter does not originate RF energy, but merely reflects back received RF energy, it is difficult to detect by an RF detector ("RF sniffer").

Even when the mobile unit navigation system 20 receives its primary operating power from the mobile unit, the navigation system 20 preferably includes an internal battery 30 to supply backup power to preserve the data stored in memory 24 in case the primary power to the mobile system 20 is disrupted, either inadvertently or by tampering. If the capacity of the internal battery 30 is only big enough to preserve the memory 24, and not big enough to power the navigation receiver 22, then there will be an absence of geographic

**SUBSTITUTE SHEET (RULE 26)**

position readings stored in memory during the period of the power disruption. When the mobile unit reaches the next base station and downloads its itinerary data to the base station, the gap in the downloaded itinerary data will indicate to the base station when the disruption or tampering occurred.

5 For compactness, low power consumption, and economy, the memory 24, controller 26, and transceiver 28 preferably are all fabricated on a single monolithic integrated circuit chip. The chip and battery 30 preferably are mounted on a single substrate using the compact mounting techniques described in commonly assigned U.S. Patent 5,448,110 and allowed U.S. patent  
10 application SN 08/168,909 filed 12/17/95, the entire contents of each of which are hereby incorporated into the present patent specification.

Since the memory 24 can store only a finite number of geographic position data points, old position data eventually must be deleted or overwritten with new data. Preferably, after successfully receiving itinerary data from a  
15 mobile unit, the base station will transmit to the mobile unit a "delete" command, in response to which the controller 26 in the mobile unit will permit deletion or overwriting of all existing itinerary data in memory 24 or a specified portion of the data.

In the preferred embodiment, the memory 24 has a capacity of 512 K  
20 (kilobytes) and can store 24,000 itinerary readings or data points. In other words, if a geographic position reading were stored in memory 24 every two minutes, it would take over 33 days to fill up the memory. Accordingly, memory overflow would be no problem so long as the mobile unit visits a base station at least once ever 33 days to download its itinerary data.

25 Optionally, a mobile unit can include various sensors in addition to the navigation receiver 22, such as temperature sensors or sensors to indicate the status of various switches, controls, or doors on the mobile unit. The data from the sensors can be stored in memory 24 along with the previously described itinerary data, and similarly can be downloaded by the transceiver 28 to a base  
30 station upon command.

**SUBSTITUTE SHEET (RULE 26)**

Although one advantage of the invention is that it overcomes the need for long-range communications, a conventional long-range communications link can be employed as an option to permit emergency communications or communications for any other purpose. The invention will still retain the  
5 advantage of not requiring such long-range link to be employed for continuous or frequent position tracking.

**SUBSTITUTE SHEET (RULE 26)**



## Claims:

1. An itinerary monitoring apparatus attached to a mobile object,  
comprising:
  - 5 a satellite navigation receiver for computing the geographic position of the mobile object;  
a memory for storing a series of itinerary data points, wherein each data point includes a position computed by the navigation receiver and a time of day corresponding to that position; and
  - 10 a radio transceiver for receiving and transmitting messages by radio communication, wherein the transceiver transmits an itinerary data message containing a number of itinerary data points stored in the memory in response to receiving an interrogation radio message.
- 15 2. Apparatus according to claim 1, wherein the transceiver does not transmit any messages containing itinerary data except in response to receiving an interrogation radio message.
3. Apparatus according to claim 2, wherein the transceiver comprises a  
20 modulated-backscatter passive RF transmitter for transmitting said itinerary data messages.
4. Apparatus according to claim 2, wherein:  
the memory further stores an identification code which identifies the  
25 mobile object; and  
the transceiver does not transmit any messages except in response to receiving an interrogation radio message containing said identification code.
5. An itinerary monitoring apparatus enabling an interrogator to monitor the  
30 itinerary of a number of mobile objects, comprising:

SUBSTITUTE SHEET (RULE 26)

(a) at least one interrogator station including a first radio transceiver for transmitting interrogation messages and receiving data messages; and

(b) a number of mobile objects, each mobile object being movable away from the interrogator station, wherein each mobile object includes:

5 (i) a satellite navigation receiver for computing the geographic position of the mobile object,

(ii) a memory for storing a series of itinerary data points, wherein each data point includes a position computed by the navigation receiver and a time of day corresponding to that position, and

10 (iii) a second radio transceiver for receiving and transmitting messages by radio communication, wherein the second transceiver transmits a radio message containing a number of itinerary data points stored in the memory in response to receiving an interrogation radio message from the first transceiver.

15 6. Apparatus according to claim 5, wherein the second transceiver in each mobile object does not transmit any messages containing itinerary data except in response to receiving an interrogation radio message.

7. Apparatus according to claim 6, wherein the second transceiver in each  
20 mobile object comprises a modulated-backscatter passive RF transmitter for transmitting said messages containing itinerary data points.

8. Apparatus according to claim 6, wherein:  
the memory in each mobile object further stores an identification code  
25 which identifies the mobile object;  
each interrogation message transmitted by the interrogator station includes the identification code of one of said mobile objects; and  
the second transceiver in each mobile object does not transmit any radio  
messages except in response to receiving an interrogation radio message  
30 containing the identification code stored in the memory of that mobile object.

**SUBSTITUTE SHEET (RULE 26)**

9. A method for an interrogator station to monitor the itinerary of a mobile object, comprising the steps of:
- the mobile object receiving signals from a navigation satellite and computing from the received signals the geographic position of the mobile object;
  - 5 the mobile object storing in memory a series of itinerary data points, wherein each data point includes one of said computed positions and a time of day corresponding to that position;
  - the interrogator station transmitting to the mobile object a radio signal
  - 10 containing an interrogation message; and
  - in response to receiving an interrogation message, the mobile object transmitting to the interrogator station a radio signal containing a number of the itinerary data points stored in the memory.

**SUBSTITUTE SHEET (RULE 26)**

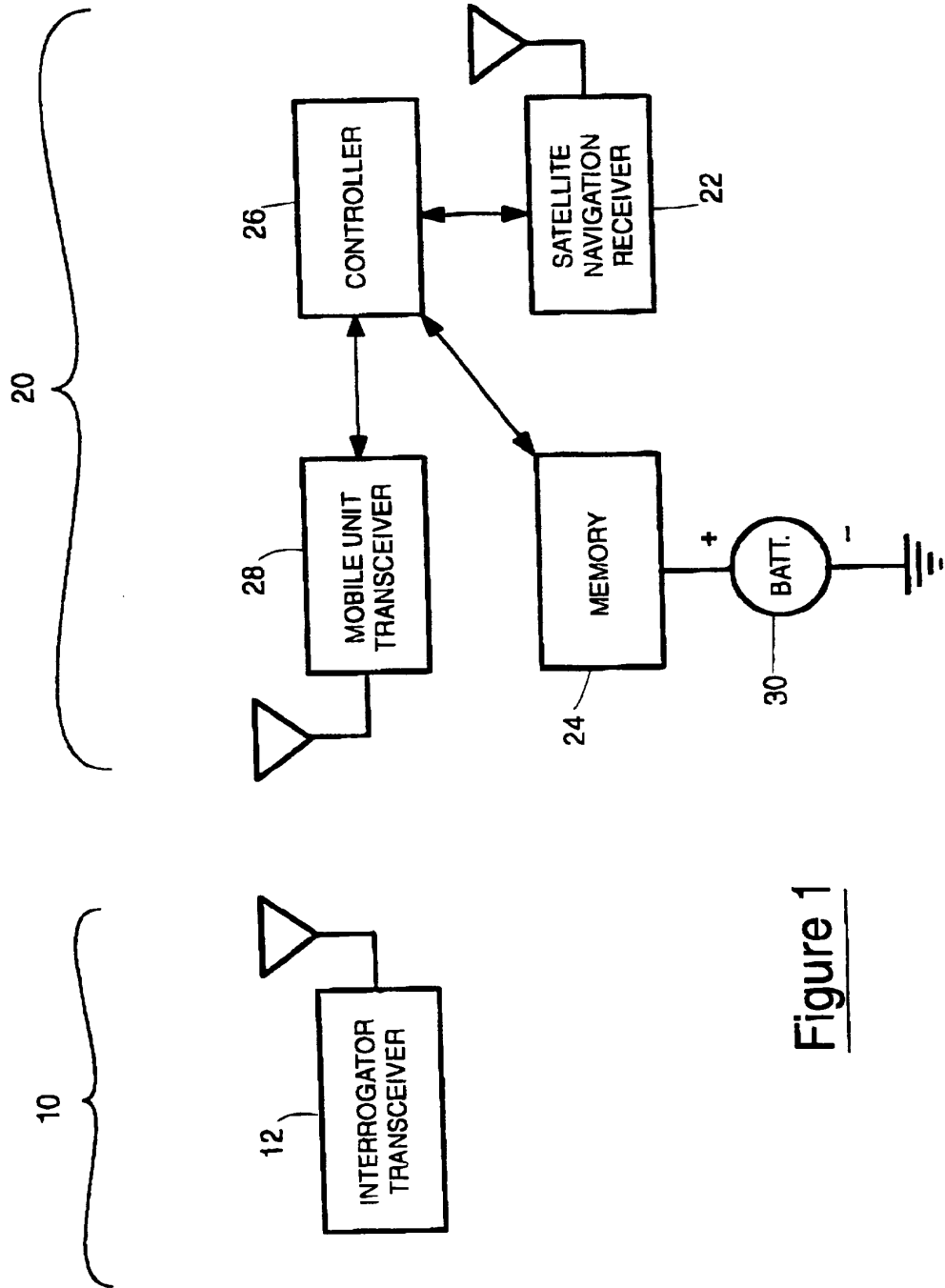


Figure 1



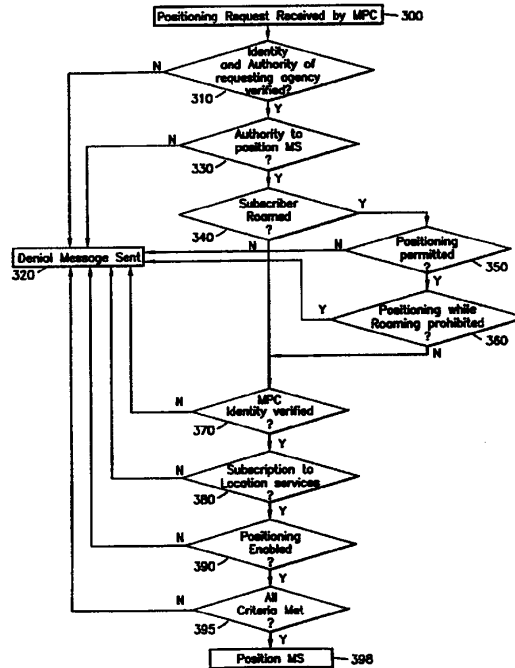
INTERNATIONAL APPLICATION PUBLISHED UNDER THE PATENT COOPERATION TREATY (PCT)

|   |                  |  |
|---|------------------|--|
| <p>(51) International Patent Classification <sup>6</sup> :<br/><b>H04Q 7/38</b></p>   | <p><b>A1</b></p> | <p>(11) International Publication Number: <b>WO 99/27746</b><br/>(43) International Publication Date: 3 June 1999 (03.06.99)</p>   |
| <p>(21) International Application Number: PCT/US98/25034<br/>(22) International Filing Date: 23 November 1998 (23.11.98)<br/>(30) Priority Data:<br/>08/978,910 26 November 1997 (26.11.97) US<br/>(71) Applicant: ERICSSON INC. [US/US]; 7001 Development Drive, P.O. Box 13969, Research Triangle Park, CA 27709 (US).<br/>(72) Inventors: KINGDON, Christopher, H.; 3038 Kingswood Drive, Garland, TX 75040 (US). ZADEH, Bagher, R.; 14332 Montfort #11207, Dallas, TX 75240 (US). MAYA, Roel-Ng; 1604 Chester Drive, Plano, TX 75025 (US). HAYES, Stephen; 2104 Via Madonna, Carrollton, TX 75006 (US).<br/>(74) Agents: MOORE, Stanley, R. et al.; Jenkins &amp; Gilchrist, P.C., Suite 3200, 1445 Ross Avenue, Dallas, TX 75202 (US).</p> |                  | <p>(81) Designated States: AL, AM, AT, AU, AZ, BA, BB, BG, BR, BY, CA, CH, CN, CU, CZ, DE, DK, EE, ES, FI, GB, GD, GE, GH, GM, HR, HU, ID, IL, IS, JP, KE, KG, KP, KR, KZ, LC, LK, LR, LS, LT, LU, LV, MD, MG, MK, MN, MW, MX, NO, NZ, PL, PT, RO, RU, SD, SE, SG, SI, SK, SL, TJ, TM, TR, TT, UA, UG, UZ, VN, YU, ZW, ARIPO patent (GH, GM, KE, LS, MW, SD, SZ, UG, ZW), Eurasian patent (AM, AZ, BY, KG, KZ, MD, RU, TJ, TM), European patent (AT, BE, CH, CY, DE, DK, ES, FI, FR, GB, GR, IE, IT, LU, MC, NL, PT, SE), OAPI patent (BF, BJ, CF, CG, CI, CM, GA, GN, GW, ML, MR, NE, SN, TD, TG).</p> <p><b>Published</b><br/><i>With international search report.</i></p> |

(54) Title: SYSTEM AND METHOD FOR AUTHORIZATION OF LOCATION SERVICES

(57) Abstract

A telecommunications system and method is disclosed which performs authorization checks prior to allowing a location service to position a mobile terminal within a cellular network. The various checks involve ensuring that the requesting agency has authorization to request positioning of mobile terminals, determining whether positioning of mobile terminals is allowed within the cellular network that the mobile terminal is currently located in, verifying the authenticity of the identity of the mobile positioning center, ascertaining whether the mobile subscriber has allowed the requesting agency to position the mobile terminal, and confirming that all relevant criteria for positioning have been met by both the mobile subscriber and the requesting agency.



**FOR THE PURPOSES OF INFORMATION ONLY**

Codes used to identify States party to the PCT on the front pages of pamphlets publishing international applications under the PCT.

|           |                          |           |  |           |  |           |                          |
|-----------|--------------------------|-----------|--|-----------|--|-----------|--------------------------|
| <b>AL</b> | Albania                  | <b>ES</b> | Spain                                    | <b>LS</b> | Lesotho                                      | <b>SI</b> | Slovenia                 |
| <b>AM</b> | Armenia                  | <b>FI</b> | Finland                                  | <b>LT</b> | Lithuania                                    | <b>SK</b> | Slovakia                 |
| <b>AT</b> | Austria                  | <b>FR</b> | France                                   | <b>LU</b> | Luxembourg                                   | <b>SN</b> | Senegal                  |
| <b>AU</b> | Australia                | <b>GA</b> | Gabon                                    | <b>LV</b> | Latvia                                       | <b>SZ</b> | Swaziland                |
| <b>AZ</b> | Azerbaijan               | <b>GB</b> | United Kingdom                           | <b>MC</b> | Monaco                                       | <b>TD</b> | Chad                     |
| <b>BA</b> | Bosnia and Herzegovina   | <b>GE</b> | Georgia                                  | <b>MD</b> | Republic of Moldova                          | <b>TG</b> | Togo                     |
| <b>BB</b> | Barbados                 | <b>GH</b> | Ghana                                    | <b>MG</b> | Madagascar                                   | <b>TJ</b> | Tajikistan               |
| <b>BE</b> | Belgium                  | <b>GN</b> | Guinea                                   | <b>MK</b> | The former Yugoslav<br>Republic of Macedonia | <b>TM</b> | Turkmenistan             |
| <b>BF</b> | Burkina Faso             | <b>GR</b> | Greece                                   | <b>ML</b> | Mali   | <b>TR</b> | Turkey                   |
| <b>BG</b> | Bulgaria                 | <b>HU</b> | Hungary                                  | <b>MN</b> | Mongolia                                     | <b>TT</b> | Trinidad and Tobago      |
| <b>BJ</b> | Benin                    | <b>IE</b> | Ireland                                  | <b>MR</b> | Mauritania                                   | <b>UA</b> | Ukraine                  |
| <b>BR</b> | Brazil                   | <b>IL</b> | Israel                                   | <b>MW</b> | Malawi                                       | <b>UG</b> | Uganda                   |
| <b>BY</b> | Belarus                  | <b>IS</b> | Iceland                                  | <b>MX</b> | Mexico                                       | <b>US</b> | United States of America |
| <b>CA</b> | Canada                   | <b>IT</b> | Italy                                    | <b>NE</b> | Niger  | <b>UZ</b> | Uzbekistan               |
| <b>CF</b> | Central African Republic | <b>JP</b> | Japan                                    | <b>NL</b> | Netherlands                                  | <b>VN</b> | Viet Nam                 |
| <b>CG</b> | Congo                    | <b>KE</b> | Kenya                                    | <b>NO</b> | Norway                                       | <b>YU</b> | Yugoslavia               |
| <b>CH</b> | Switzerland              | <b>KG</b> | Kyrgyzstan                               | <b>NZ</b> | New Zealand                                  | <b>ZW</b> | Zimbabwe                 |
| <b>CI</b> | Côte d'Ivoire            | <b>KP</b> | Democratic People's<br>Republic of Korea | <b>PL</b> | Poland                                       |           |                          |
| <b>CM</b> | Cameroon                 | <b>KR</b> | Republic of Korea                        | <b>PT</b> | Portugal                                     |           |                          |
| <b>CN</b> | China                    | <b>KZ</b> | Kazakistan                               | <b>RO</b> | Romania                                      |           |                          |
| <b>CU</b> | Cuba                     | <b>LC</b> | Saint Lucia                              | <b>RU</b> | Russian Federation                           |           |                          |
| <b>CZ</b> | Czech Republic           | <b>LI</b> | Liechtenstein                            | <b>SD</b> | Sudan  |           |                          |
| <b>DE</b> | Germany                  | <b>LK</b> | Sri Lanka                                | <b>SE</b> | Sweden                                       |           |                          |
| <b>DK</b> | Denmark                  | <b>LR</b> | Liberia                                  | <b>SG</b> | Singapore                                    |           |                          |
| <b>EE</b> | Estonia                  |           |  |           |  |           |                          |

## SYSTEM AND METHOD FOR AUTHORIZATION OF LOCATION SERVICES

### BACKGROUND OF THE PRESENT INVENTION

5

#### Field of the Invention

The present invention relates generally to telecommunications systems and method for determining the location of a mobile terminal within a cellular network, and specifically to performing authorization checks prior to positioning the mobile terminal.

10

#### Background and Objects of the Present Invention

15

Cellular telecommunications is one of the fastest growing and most demanding telecommunications applications ever. Today it represents a large and continuously increasing percentage of all new telephone subscriptions around the world. A standardization group, European Telecommunications Standards Institute (ETSI), was established in 1982 to formulate the specifications for the Global System for Mobile Communication (GSM) digital mobile cellular radio system.

20

With reference now to FIGURE 1 of the drawings, there is illustrated a GSM Public Land Mobile Network (PLMN), such as cellular network 10, which in turn is composed of a plurality of areas 12, each with a Mobile Switching Center (MSC) 14 and an integrated Visitor Location Register (VLR) 16 therein. The MSC/VLR areas 12, in turn, include a plurality of Location Areas (LA) 18, which are defined as that part of a given MSC/VLR area 12 in which a mobile station (MS) (terminal) 20 may move freely without having to send update location information to the MSC/VLR area 12 that controls the LA 18. Each Location Area 12 is divided into a number of cells 22. Mobile Station (MS) 20 is the physical equipment, e.g., a car phone or other portable phone, used by mobile subscribers to communicate with the cellular network 10, each other, and users outside the subscribed network, both wireline and wireless.

25

30

The MSC 14 is in communication with at least one Base Station Controller (BSC) 23, which, in turn, is in contact with at least one Base Transceiver Station

-2-

(BTS) 24. The BTS is the physical equipment, illustrated for simplicity as a radio tower, that provides radio coverage to the cell 22 for which it is responsible. It should be understood that the BSC 23 may be connected to several base transceiver stations 24, and may be implemented as a stand-alone node or integrated with the MSC 14. In either event, the BSC 23 and BTS 24 components, as a whole, are generally referred to as a Base Station System (BSS) 25.

With further reference to FIGURE 1, the PLMN Service Area or cellular network 10 includes a Home Location Register (HLR) 26, which is a database maintaining all subscriber information, e.g., user profiles, current location information, International Mobile Subscriber Identity (IMSI) numbers, and other administrative information. The HLR 26 may be co-located with a given MSC 14, integrated with the MSC 14, or alternatively can service multiple MSCs 14, the latter of which is illustrated in FIGURE 1.

The VLR 16 is a database containing information about all of the Mobile Stations 20 currently located within the MSC/VLR area 12. If a MS 20 roams into a new MSC/VLR area 12, the VLR 16 connected to that MSC 14 will request data about that Mobile Station 20 from the HLR database 26 (simultaneously informing the HLR 26 about the current location of the MS 20). Accordingly, if the user of the MS 20 then wants to make a call, the local VLR 16 will have the requisite identification information without having to reinterrogate the HLR 26. In the aforescribed manner, the VLR and HLR databases 16 and 26, respectively, contain various subscriber information associated with a given MS 20.

Determining the geographical position of a MS within a cellular network has recently become important for a wide range of applications. For example, positioning services may be used by transport and taxi companies to determine the location of their vehicles. In addition, for emergency calls, e.g., 911 calls, the exact location of the mobile terminal may be extremely important to the outcome of the emergency situation. Furthermore, positioning services can be used to determine the location of a stolen car, for the detection of home zone calls, which are charged at a lower rate, for the detection of hot spots for micro cells, or for the subscriber to determine, for example, the nearest gas station, restaurant, or hospital.



-3-

Currently, as can be seen in FIGURE 2 of the drawings, upon a network positioning request, the Base Station System (BSS) (220 and 240) serving the MS 200 generates positioning data, which is delivered to the Mobile Switching Center (MSC) 260. This positioning data is then forwarded to a Mobile Positioning Center (MPC) 270 for calculation of the geographical location of the MS 200. The location of the MS 200 can then be sent to the application 280 that requested the positioning. Alternatively, the requesting application 280 could be located within the MS 200 itself or within the network (MSC/VLR 260).

In order to accurately determine the location of the MS 200, positioning data from three or more separate Base Transceiver Stations (210, 220, and 230) is required. This positioning data for GSM systems can include, for example, a Timing Advance (TA) value, which corresponds to the amount of time in advance that the MS 200 must send a message in order for the BTS 220 to receive it in the time slot allocated to that MS 200. When a message is sent from the MS 200 to the BTS 220, there is a propagation delay, which depends on the distance between the MS 200 and the BTS 220. TA values are expressed in bit periods, and can range from 0 to 63, with each bit period corresponding to approximately 550 meters between the MS 200 and the BTS 220. It should be understood, however, that any estimate of time, distance, or angle for any cellular system can be used, instead of the TA value discussed herein.

Once a TA value is determined for one BTS 220, the distance between the MS 200 and that particular BTS 220 is known, but the actual location is not. If, for example, the TA value equals one, the MS 200 could be anywhere along a radius of 550 meters. Two TA values from two BTSs, for example, BTSs 210 and 220, provide two possible points that the MS 200 could be located (where the two radiuses intersect). However, with three TA values from three BTSs, e.g., BTSs 210, 220, and 230, the location of the MS 200 can be determined with a certain degree of accuracy. Using a triangulation algorithm, with knowledge of the three TA values and site location data associated with each BTS (210, 220, and 230), the position of the mobile station 200 can be determined (with certain accuracy) by the Mobile Positioning Center (MPC) 270.

-4-

Therefore, Timing Advance (TA) values are obtained from the original (serving) BTS 220 and two neighboring (target) BTSs (210 and 230). In order for each target BTS (210 and 230) to determine a TA value, a positioning handover to each of the BTSs (210 and 230) must occur. A positioning handover is similar to an ordinary asynchronous handover. The target BTS, e.g., BTS 210, distinguishes the Positioning Handover from an ordinary handover by a new ACTIVATION TYPE in the CHANNEL ACTIVATION message. Unlike an ordinary handover, upon reception of a HANDOVER ACCESS message from the MS 200, the target BTS 210 only calculates the TA value, and does not respond to the mobile station 200, that is, no PHYSICAL INFORMATION is sent to the MS 200. Thus, the MS 200 will then return to the previous channel allocated by the original BTS 220 after the time period defined by the MS's 200 internal counter expires, e.g., 320 milliseconds.

Location services have a high potential for invasion of a subscriber's privacy. This is especially true when commercial applications are given the ability to access the location services. Proper authorization and access capabilities must be provided to prevent misuse and allow the subscriber to have adequate control over the ability of external parties to determine his or her location. In addition, these authorization procedures must provide adequate protection even when the subscriber is roaming.

Currently, authorization procedures exist for only a limited set of location services. These procedures do not include the ability to handle roaming subscribers, and can only be applied to services which have the ability to locate only subscribers within a certain group (Location of Subscriber within Group (LSG) services). In addition, the subscriber typically does not have ability to prevent positioning.

A previously considered solution to the problem of privacy for positioning includes a subscriber settable option disabling/enabling all application initiated location capabilities. However, this option disables all application initiated location queries, and if the subscriber chooses to enable the application initiated queries, any agency subscribing to positioning capabilities, which has the subscriber's number can position the MS at any time.

Another considered solution would permit positioning by setting an indicator on the phone. However, enabling positioning is intrusive, and there is currently no

-5-

existing mechanism on MSs to enable positioning. Furthermore, it is difficult for the MS to determine when the application has finished positioning the MS (multiple positionings may be required).

Another considered solution would provide a confirmation dialog in which the subscriber must either permit or disallow the positioning request. However, this solution is also intrusive. If the user does not successfully indicate acceptance in the dialog, the positioning will not occur.

It is therefore an object of the invention to provide authorization checking of location applications prior to positioning a mobile terminal within a cellular network.

10

#### **SUMMARY OF THE INVENTION**

The present invention is directed to telecommunications systems and methods which perform authorization checks prior to allowing a location service to position a mobile terminal within a cellular network. The various checks involve ensuring that the requesting agency has authorization to request positioning of mobile terminals, determining whether positioning of mobile terminals is allowed within the cellular network that the mobile terminal is currently located in, verifying the authenticity of the identity of the mobile positioning center, ascertaining whether the mobile subscriber has allowed the requesting agency to position the mobile terminal, and confirming that all relevant criteria for positioning have been met by both the mobile subscriber and the requesting agency. For example, in some circumstances, an agency may only be permitted to position a mobile terminal while that mobile terminal has a call established to a specific number (or set of numbers). In that case, each agency positioning request is screened against a directory number or set of directory numbers specific to that agency. The agency requesting the positioning (taxi company, police, etc.) is interfaced with a location application, which is interfaced with a local Mobile Positioning Center (MPC). This location application will request the MPC to position a mobile terminal with a certain directory number on behalf of a given agency. The MPC will only permit the positioning to occur if that mobile terminal currently has a call established to one of the numbers associated with the given agency. Otherwise, the positioning request is rejected.

30

-6-

**BRIEF DESCRIPTION OF THE DRAWINGS**

The disclosed inventions will be described with reference to the accompanying drawings, which show important sample embodiments of the invention and which are incorporated in the specification hereof by reference, wherein:

5           FIGURE 1 is a block diagram of a conventional terrestrially-based wireless telecommunications system;

          FIGURE 2 illustrates a sample positioning handover in which positioning data is acquired by a target base transceiver station and transmitted to a serving base station controller;

10           FIGURE 3 demonstrates sample steps in an authorization process for positioning of a specific mobile terminal within a cellular network in accordance with preferred embodiments of the present invention;

          FIGURE 4 describes a sample flow for validating the authority of an agency to position a mobile terminal based upon criteria to be met by both the mobile terminal and the requesting agency in accordance with preferred embodiments of the present invention; and

          FIGURE 5 depicts steps in a sample positioning process after authorization for positioning has been obtained in accordance with preferred embodiments of the present invention.

20

**DETAILED DESCRIPTION OF THE PRESENTLY PREFERRED EXEMPLARY EMBODIMENTS**

The numerous innovative teachings of the present application will be described with particular reference to the presently preferred exemplary embodiment. However, it should be understood that this class of embodiments provides only a few examples of the many advantageous uses of the innovative teachings herein. In general, statements made in the specification of the present application do not necessarily delimit any of the various claimed inventions. Moreover, some statements may apply to some inventive features but not to others.

30           With reference now to FIGURE 3 of the drawings, steps in a sample authorization process for positioning of a specific Mobile Station (MS) 200 within a cellular network 205 are illustrated. Initially, when a positioning request is received

-7-

by a local (serving) or home Mobile Positioning Center (MPC) 270 (step 300), the local or home MPC 270 must verify the identity of the requesting agency 280 and the authority of that agency 280 to request positioning (step 310). This can be accomplished by the MPC 270 cross-checking the identity of the requesting agency 280 with a list of agencies (location nodes) stored within a database 275 the MPC 270 that have the authority to position mobile stations 200. If the requesting agency 280 is not a valid agency or does not have authority to position mobile stations 200 (step 310), a message indicating that positioning is denied is sent to the requesting agency 280 (step 320). The following authorization checks, with the exception of the verification of the identity of the requesting MPC 270, can be bypassed if the requesting agency 280 is a law enforcement agency or an emergency center.

However, if the requesting agency 280 is valid and does have authority to position mobile stations (step 310), the serving MPC 270 (either home or local depending upon the current location of the MS 200) can optionally further check the authority of the requesting agency 280 to position the specific MS 200 requested (step 330). For example, if the requesting agency 280 is only permitted to position specific MSs 200 within a group of MSs 200, e.g., a taxi service connected to the home PLMN 205 can request the location of taxi mounted MSs, the membership of the specific MS 200 to the group must be confirmed. Typically, the MPC 270 verifies that the identity of the MS 200 to be positioned, e.g., the International Mobile Subscriber Identity (IMSI) number, is within a list of mobile identities allowed to be positioned by the requesting agency 280. This list could be provided by the requesting agency 280 when the requesting agency 280 registers with the home MPC 270, or could be stored in the home MPC 270. If the specific MS 200 to be positioned has roamed outside of the home Public Land Mobile Network (PLMN) 205, the serving MPC (not shown) could then request this list from the home MPC 270. If the identity of the MS 200 is not within the list of allowable mobile identities to position, a message indicating that positioning is denied can be sent to the requesting agency 280 (step 320).

If the subscriber has roamed into a new PLMN (not shown) (step 340), the serving MPC (not shown) must ascertain whether positioning of MSs 200 is permitted within the serving PLMN (not shown) (step 350). If positioning of the roaming MS

-8-

200 is not allowed (step 350), a message indicating positioning is denied is sent to the requesting agency 280 (step 320). Furthermore, the home MPC 270 may prohibit the serving MPC from positioning the MS 200 when the MS 200 has roamed. The serving MSC/VLR (not shown) must ascertain whether positioning of the MS 200 is restricted when the MS 200 is roaming (step 360), e.g., by querying the HLR 265, and if positioning is restricted (step 360), a denial message must be sent to the requesting agency 280 (step 320). Alternatively, all information regarding positioning can be sent to the serving MSC/VLR when a location update is performed by the MS 200.

If positioning of the MS 200 is allowed in the serving PLMN (step 350 and 360), the serving MSC/VLR must further verify the identity of the requesting MPC 270 (step 370) by determining the identity of the home MPC 270, e.g., by querying the Home Location Register (HLR) 265 or by checking the subscriber record sent by the HLR 265 to the serving MSC/VLR when a location update was performed, and cross-checking that identity with the identity of the requesting MPC 270. If the requesting MPC 270 is not the home MPC 270 (step 370), a denial message is sent to the requesting agency 280 (step 320).

Thereafter, the serving or home MSC/VLR 260 checks the subscriber record obtained from the HLR 265 to ensure that the subscriber associated with the MS 200 to be positioned has subscribed to the positioning service offered by the requesting agency 280 (step 380) and that the subscriber has enabled the positioning by the requesting agency 280 (step 390). For example, a requesting agency 280 could provide location services for MS-requested positioning. In that case, the serving or home MSC/VLR 260 must determine whether the subscriber has subscribed to the location services provided by the requesting agency 280 (step 380) and whether the subscriber has enabled the positioning (step 390), e.g., that the request for positioning came from the MS 200. If the subscriber has not subscribed to the service or has disabled (or not activated) the service, a denial message is sent to the requesting agency 280 (step 320)

Finally, the serving or home MPC 270 must validate that all criteria for positioning has been met (step 395). If so, then the MS 200 can be positioned (step 398). For example, when an external agency 280 positions a MS 200 in order to

-9-

provide a service or assist the mobile subscriber, the subscriber should be able to restrict the external agency 280 from positioning the MS 200 if the mobile subscriber does not need the service. The Location of Subscriber while Connected (LSC) service provides one way of accomplishing this. For example, the LSC service can be used  
5 by a taxi service to determine the subscriber's location and then to dispatch a taxi to that location. In addition, such LSC services are useful for wrecker company's, and emergency calls.

Such agencies 280 can only position a MS 200 while that MS 200 has a call established to a specific number (or set of numbers). Thus, the taxi company could  
10 only position mobile stations 200 that called it's number to order a taxi. Each agency's 280 positioning requests would be screened by the MPC 270 against a directory number or set of directory numbers specific to that agency 280.

With reference now to FIGURE 4 of the drawings, a sample flow for validating the authority of an agency 280 to position a mobile station (MS) 200 based upon  
15 criteria to be met by both the MS 200 and the requesting agency 280 is depicted. The agency requesting the positioning (taxi company, police, etc.) will be interfacing with a location application 280 (step 400), which is interfaced with a local Mobile Positioning Center (MPC) 270 (step 410). The set of directory numbers valid for the agency represented by that application 280 is communicated to the MPC 270 (step  
20 430) when the location application 280 registers with the MPC 270 (step 420). This application 280 will request the MPC 270 to position a MS 200 with a certain directory number on behalf of agency xxx (step 440). The MPC 270 will only permit the positioning to occur (step 460) if that MS 200 currently has a call established to one of the numbers associated with agency xxx (step 450). Otherwise, the positioning  
25 request is rejected (step 470).

With reference now to FIGURE 5 of the drawings, after the authorization of the requesting agency to position the MS has been confirmed, positioning of the MS  
200 continues with the MPC 270 forwarding the positioning request to the serving Mobile Switching Center/Visitor Location Register 260 (step 500). The MPC 270 can  
30 be located within the MSC/VLR 260, or could be a separate node in communication with the MSC/VLR 260. The serving MSC/VLR 260 then forwards the positioning

-10-

request to the BSC 240 (step 510). If the MS 200 is in idle mode (not in use), the MSC/VLR 260 must page the MS 200 and set up a call to the MS 200 prior to forwarding the positioning request to the BSC 240 (step 510). This call does not activate the ringing tone on the MS 200, and therefore, is not noticed by the MS 200.

5           The originating BSC 240 then determines which Base Transceiver Station (BTS) 220 is currently serving the MS 200 (step 520), and obtains a Timing Advance (TA) value (TA1), or other positioning data, from this serving BTS 220 (step 525), if possible. Thereafter, TA values are obtained from two target BTSs (210 and 230) (step 560) by performing a positioning handover (step 530). If the serving BTS 220  
10 does not support positioning, an additional target BTS (not shown) must be selected. It should be noted that other positioning methods based on triangulation can be used instead of obtaining TA values, as discussed herein. In addition, positioning of the MS 200 can be performed using more than three BTSs (210, 220, and 230).

          The positioning handover to one of the target BTSs 230 (step 530) is  
15 accomplished by the serving BSC 240 sending a new ACTIVATION TYPE in a CHANNEL ACTIVATION message to the target BTS 230, which informs the target BTS 230 that a positioning handover needs to be performed (step 535). The target BTS 230 then acknowledges the CHANNEL ACTIVATION message to the serving BSC 250 (step 540).

20           Thereafter, the BSC 240 sends a command to the MS 200 via the serving BTS 220 (step 545) to transmit a HANDOVER ACCESS message to the target BTS 230 (step 550). During the time that the MS 200 is waiting for a response from the target BTS 230, e.g., around 320 milliseconds, the target BTS 230 measures the Timing Advance value (access delay) (TA3) (step 555), using access bursts sent by the MS  
25 200, and forwards this positioning data to the serving BSC 240 (step 560). A positioning handover can then be performed to the other target BTS 210 in the same manner as stated hereinbefore. The TA value measured by the target BTS 230 (TA3) is then transmitted by the serving BSC 250 to the MSC 260 (step 565), together with TA values (TA1 and TA2) obtained from the serving BTS 220 and other target BTSs  
30 210.



-11-

Finally, the TA value acquired from the target BTS 230 (TA3), together with other TA values (TA1 and TA2) are forwarded to the Mobile Positioning Center (MPC) 270 from the MSC 260 (step 570), where the location of the MS 200 is determined using the triangulation algorithm (step 575). The MPC 270 then presents  
5 the geographical position of the MS 200 to the requesting agency (node) 280 (step 580).

As will be recognized by those skilled in the art, the innovative concepts described in the present application can be modified and varied over a tremendous range of applications. Accordingly, the scope of patented subject matter should not  
10 be limited to any of the specific exemplary teachings discussed.

-12-

**WHAT IS CLAIMED IS:**

1. A telecommunications system for performing authorization checks prior to positioning a mobile terminal within a cellular network, said mobile terminal being in wireless communication with a mobile switching center, said telecommunications system comprising:
- 5 a mobile positioning center in communication with said mobile switching center, said mobile positioning center having a database therein, said database containing a list of authorized location nodes; and
- 10 a requesting node having an identity associated therewith, said requesting node sending a positioning request and said identity to said mobile positioning center, said mobile positioning center checking said identity against said list of authorized location nodes, said mobile positioning center sending a denial message to said requesting node when said identity is not on said list.
- 15 2. The telecommunications system of Claim 1, wherein said mobile terminal has an identity associated therewith, said mobile positioning center sending said denial message when said identity associated with said mobile terminal is not within a list of mobile identities sent by said requesting node to said mobile positioning center.
- 20 3. The telecommunications system of Claim 1, wherein said denial message is sent by said mobile positioning center to said requesting node when positioning of said mobile terminal is not allowed within said cellular network.
- 25 4. The telecommunications system of Claim 1, further comprising a home location register in communication with said mobile switching center.
- 30 5. The telecommunications system of Claim 4, wherein said home location register sends a valid positioning identity to said mobile switching center, said positioning request being sent by said requesting node to a home positioning node having an identity associated therewith, said home positioning node forwarding said

-13-

positioning request and said identity associated with said home positioning node to said mobile switching center, said mobile positioning center sending said denial message to said requesting node when said identity associated with said home positioning node is not said valid positioning identity.

5

6. The telecommunications system of Claim 4, wherein said home location register sends a positioning subscription associated with said mobile terminal to said mobile switching center, said mobile switching center checking said identity associated with said requesting node against said positioning subscription, said mobile positioning center sending said denial message to said requesting node when said identity is not within said positioning subscription.

10

7. The telecommunications system of Claim 6, wherein said mobile terminal has an enabling feature associated therewith, said mobile positioning center sending said denial message to said requesting node when said enabling feature is not activated.

15

8. The telecommunications system of Claim 1, wherein said mobile terminal is connected to a subscriber having a call number associated therewith, said requesting node having a list of valid numbers stored therein, said list of valid numbers being sent to said mobile positioning center, said mobile positioning center checking said call number against said list of valid numbers, said mobile positioning center sending said denial message to said requesting node when said call number is not within said list of valid numbers.

20  
25

9. A method for performing authorization checks prior to positioning a mobile terminal within a cellular network, said mobile terminal being in wireless communication with a mobile switching center, said method comprising the steps of:  
storing, within a database within a mobile positioning center in communication with said mobile switching center, a list of authorized location nodes;  
sending, by a requesting node having an identity associated therewith, a

30

-14-

positioning request and said identity to said mobile positioning center;

checking, by said mobile positioning center, said identity against said list of authorized location nodes; and

5 sending, by said mobile positioning center, a denial message to said requesting node when said identity is not on said list.

10 10. The method of Claim 9, wherein said mobile terminal has an identity associated therewith, and further comprising, after said step of sending said denial message, the step of:

10 sending, by said mobile positioning center, said denial message when said identity associated with said mobile terminal is not within a list of mobile identities sent by said requesting node to said mobile positioning center.

15 11. The method of Claim 9, further comprising, after said step of sending said denial message, the step of:

sending said denial message by said mobile positioning center to said requesting node when positioning of said mobile terminal is not allowed within said cellular network.

20 12. The method of Claim 9, wherein a home location register is in communication with said mobile switching center.

13. The method of Claim 12, further comprising, before said step of sending said positioning request, the steps of:

25 sending, by said home location register, a valid positioning identity to said mobile switching center;

sending, by said requesting node, said positioning request to a home positioning node having an identity associated therewith;

30 sending, by said home positioning node, said positioning request and said identity associated with said home positioning node to said mobile switching center; and

-15-

sending, by said mobile positioning center, said denial message to said requesting node when said identity associated with said home positioning node is not said valid positioning identity.

5           14.    The method of Claim 12, further comprising, after said step of storing, the steps of:

sending, by said home location register, a positioning subscription associated with said mobile terminal to said mobile switching center;

10           checking, by said mobile switching center, said identity associated with said requesting node against said positioning subscription; and

sending, by said mobile positioning center, said denial message to said requesting node when said identity is not within said positioning subscription.

15           15.    The method of Claim 14, wherein said mobile terminal has an enabling feature associated therewith, said mobile positioning center sending said denial message to said requesting node when said enabling feature is not activated.

20           16.    The method of Claim 9, wherein said mobile terminal is connected to a subscriber having a call number associated therewith, said requesting node having a list of valid numbers stored therein, and further comprising, after said step of storing, the steps of:

sending said list of valid numbers from said requesting node to said mobile positioning center;

25           checking, by said mobile positioning center, said call number against said list of valid numbers; and

sending, by said mobile positioning center, said denial message to said requesting node when said call number is not within said list of valid numbers.

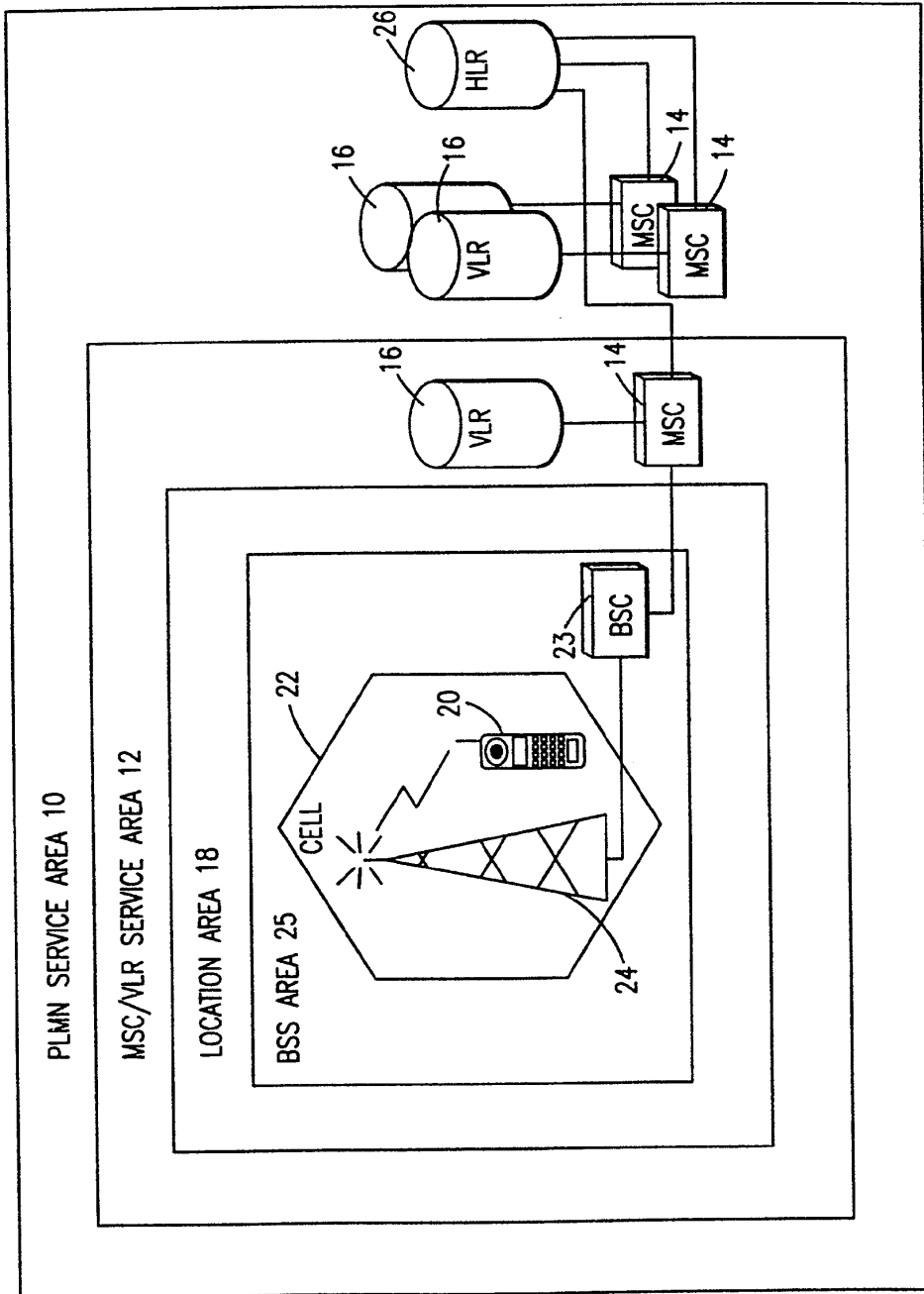


FIG. 1

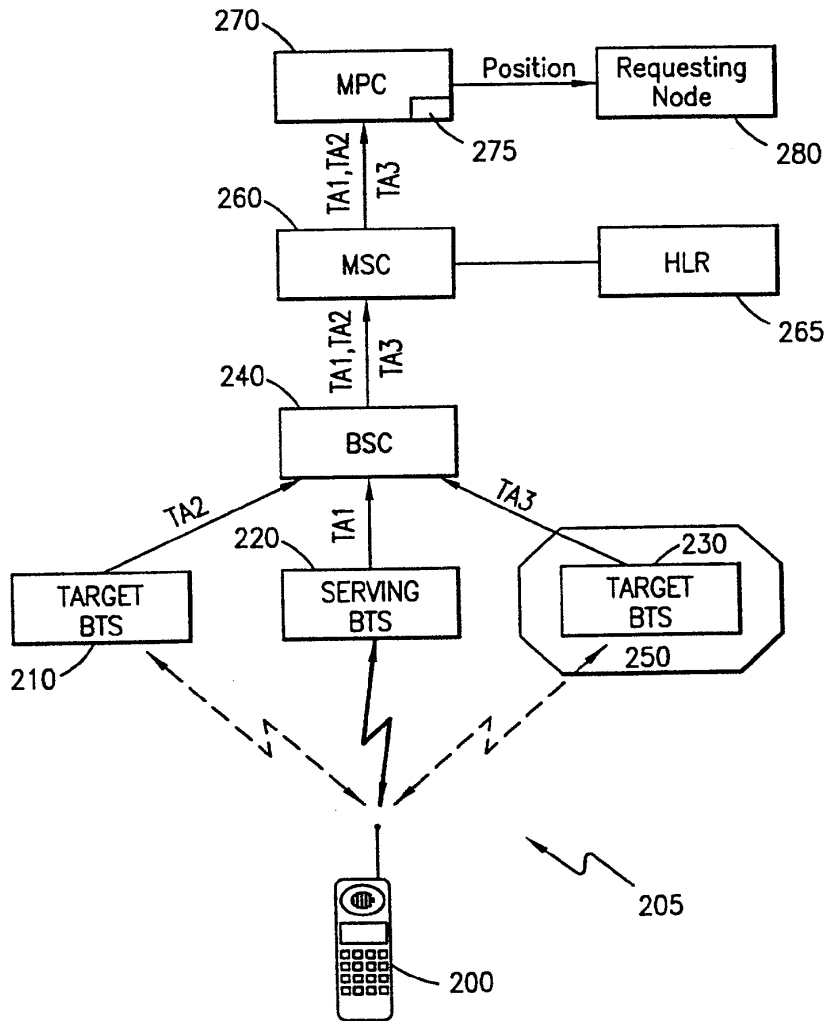


FIG. 2

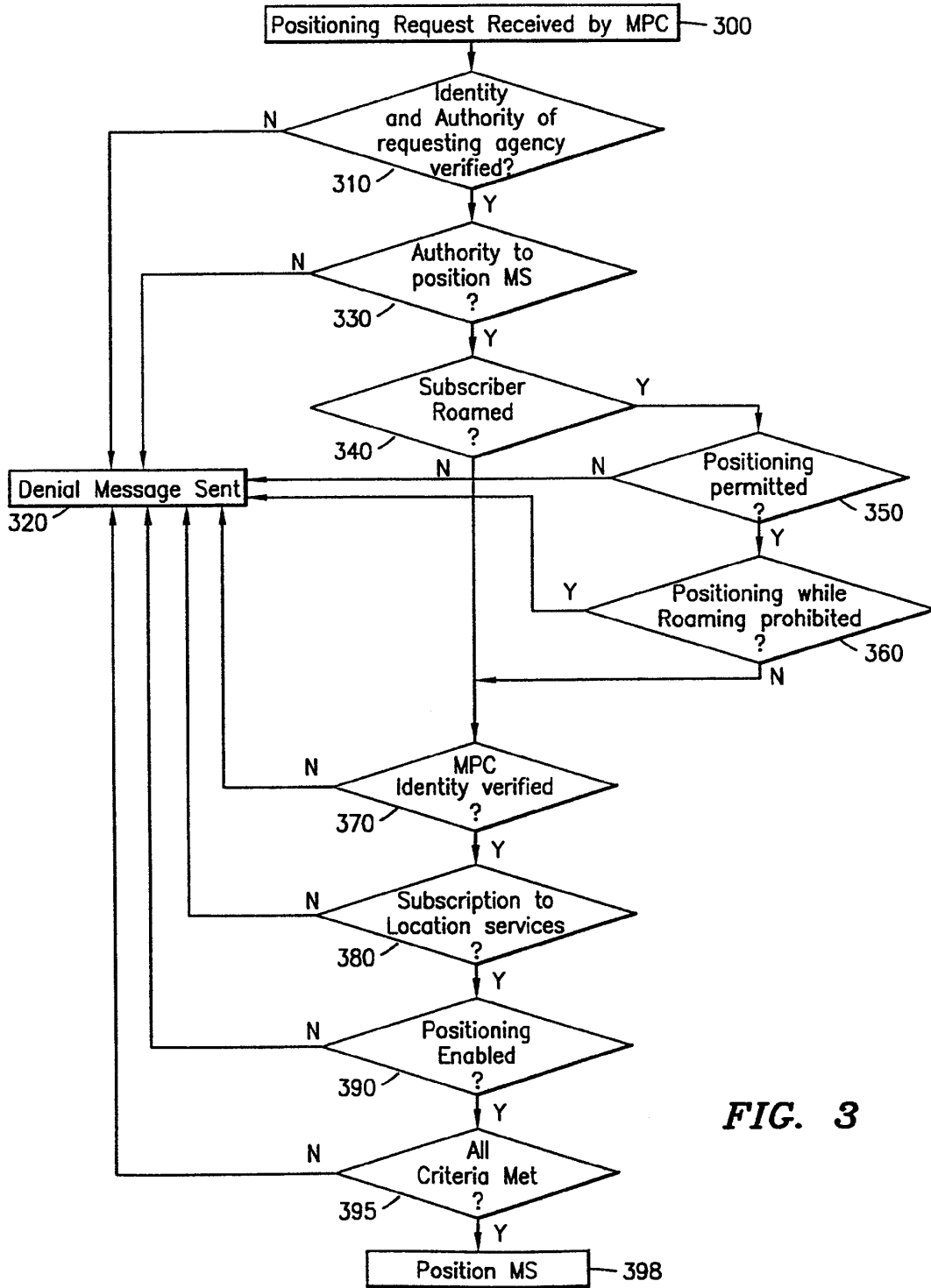


FIG. 3



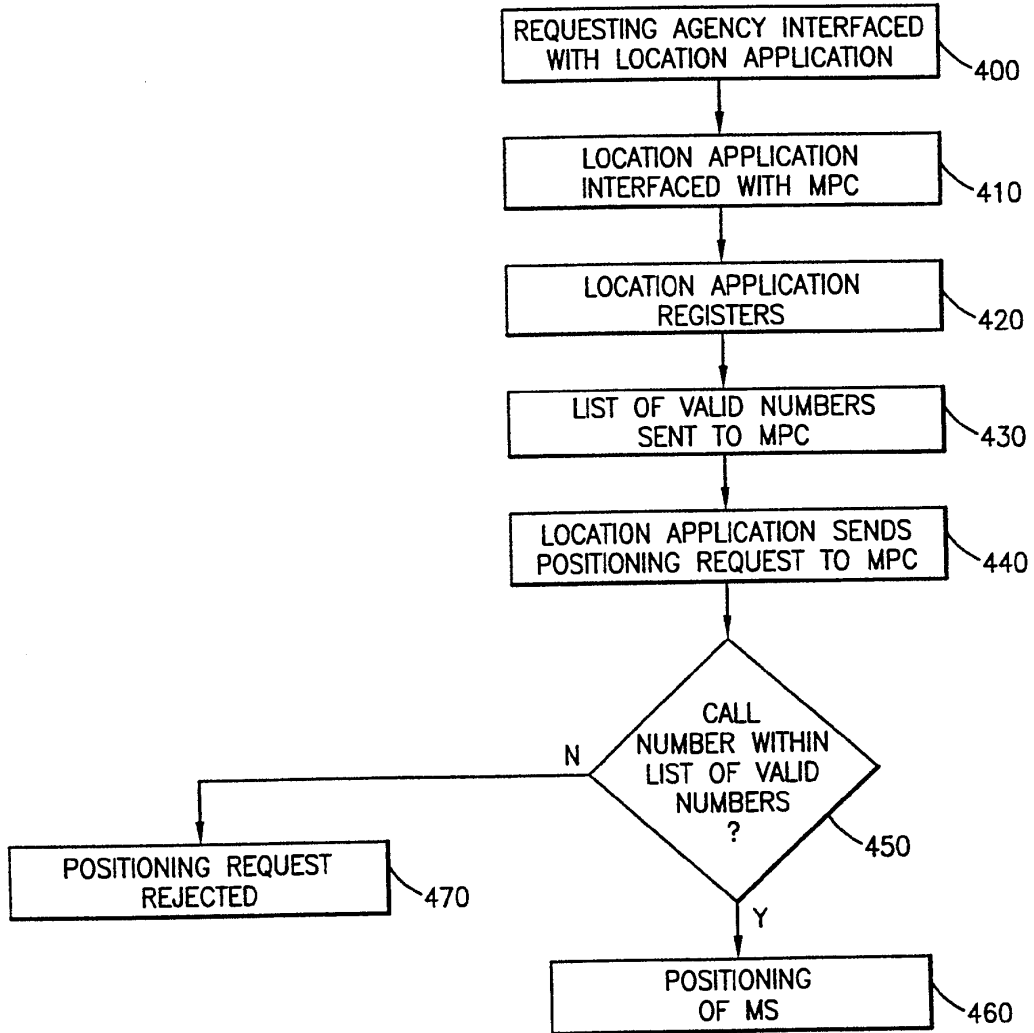
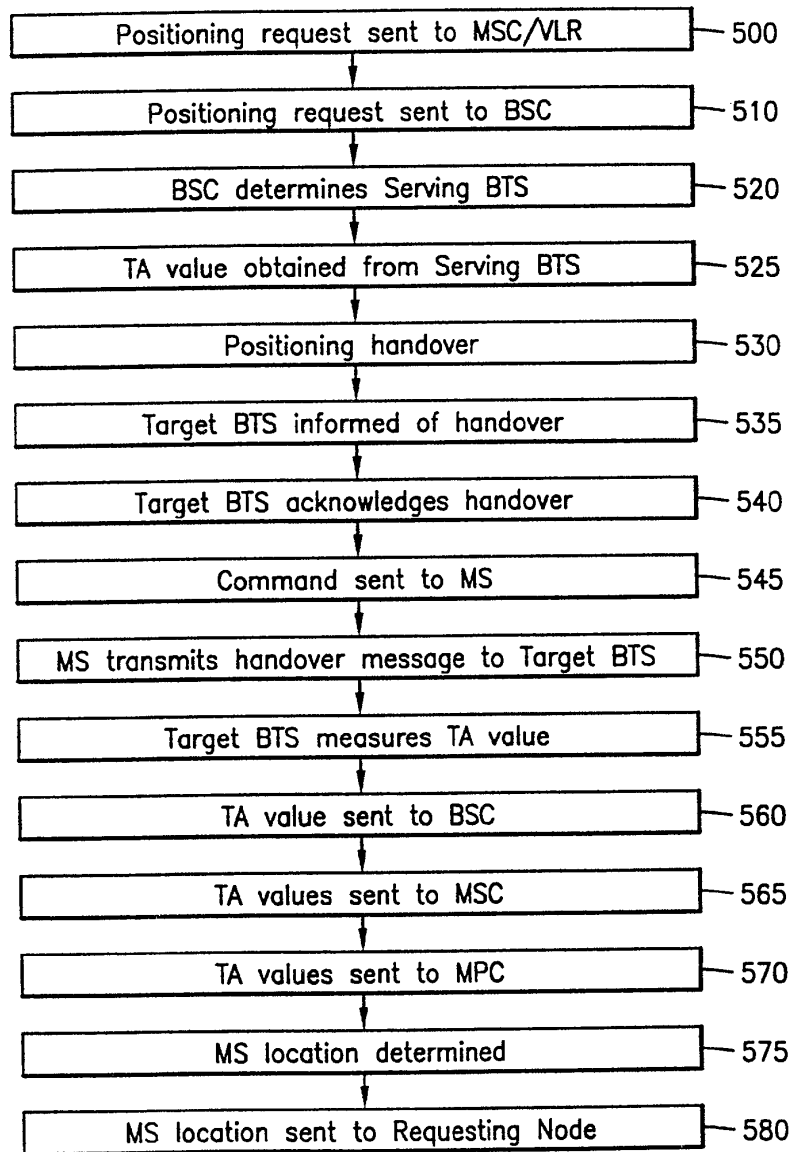


FIG. 4



**FIG. 5**

# INTERNATIONAL SEARCH REPORT

International Application No  
PCT/US 98/25034

|  |   |   |   |   |
|--|---|---|---|---|
| <b>A. CLASSIFICATION OF SUBJECT MATTER</b><br>IPC 6 H04Q7/38   |   |   |   |   |
| According to International Patent Classification (IPC) or to both national classification and IPC  |   |   |   |   |
| <b>B. FIELDS SEARCHED</b>  |   |   |   |   |
| Minimum documentation searched (classification system followed by classification symbols)<br>IPC 6 H04Q  |   |   |   |   |
| Documentation searched other than minimum documentation to the extent that such documents are included in the fields searched  |   |   |   |   |
| Electronic data base consulted during the international search (name of data base and, where practical, search terms used)   |   |   |   |   |
| <b>C. DOCUMENTS CONSIDERED TO BE RELEVANT</b>  |   |   |   |   |
| Category *   | Citation of document, with indication, where appropriate, of the relevant passages  | Relevant to claim No.   |   |   |
| A  | US 5 485 163 A (SINGER MARTIN H ET AL)<br>16 January 1996<br>see column 1, line 49 - line 55<br>see column 3, line 58 - line 67<br>see column 6, line 52 - line 56<br>----  |   |   |   |
| A  | EP 0 600 162 A (DETECON GMBH) 8 June 1994<br>see column 1, line 55 - column 2, line 11<br>----  |   |   |   |
| P,A  | US 5 748 148 A (MALVINO JOANNA MARY ET AL) 5 May 1998<br>see column 2, line 12 - line 16<br>see column 12, line 49 - line 67; figure 11   |   |   |   |
| A  | & WO 97 13160 A<br>----   |   |   |   |
| A  | DE 297 05 537 U (C.WEBER) 6 November 1997<br>see page 1, paragraph 6; claim 2; figure<br>-----  |   |   |   |
| <input type="checkbox"/> Further documents are listed in the continuation of box C.  |   |   |   |   |
| <input checked="" type="checkbox"/> Patent family members are listed in annex.   |   |   |   |   |
| * Special categories of cited documents :  |   |   |   |   |
| <table style="width: 100%; border: none;"> <tr> <td style="width: 50%; border: none; vertical-align: top;">                     "A" document defining the general state of the art which is not considered to be of particular relevance<br/>                     "E" earlier document but published on or after the international filing date<br/>                     "L" document which may throw doubts on priority claim(s) or which is cited to establish the publication date of another citation or other special reason (as specified)<br/>                     "O" document referring to an oral disclosure, use, exhibition or other means<br/>                     "P" document published prior to the international filing date but later than the priority date claimed                 </td> <td style="width: 50%; border: none; vertical-align: top;">                     "T" later document published after the international filing date or priority date and not in conflict with the application but cited to understand the principle or theory underlying the invention<br/>                     "X" document of particular relevance; the claimed invention cannot be considered novel or cannot be considered to involve an inventive step when the document is taken alone<br/>                     "Y" document of particular relevance; the claimed invention cannot be considered to involve an inventive step when the document is combined with one or more other such documents, such combination being obvious to a person skilled in the art.<br/>                     "&amp;" document member of the same patent family                 </td> </tr> </table> |   |   | "A" document defining the general state of the art which is not considered to be of particular relevance<br>"E" earlier document but published on or after the international filing date<br>"L" document which may throw doubts on priority claim(s) or which is cited to establish the publication date of another citation or other special reason (as specified)<br>"O" document referring to an oral disclosure, use, exhibition or other means<br>"P" document published prior to the international filing date but later than the priority date claimed | "T" later document published after the international filing date or priority date and not in conflict with the application but cited to understand the principle or theory underlying the invention<br>"X" document of particular relevance; the claimed invention cannot be considered novel or cannot be considered to involve an inventive step when the document is taken alone<br>"Y" document of particular relevance; the claimed invention cannot be considered to involve an inventive step when the document is combined with one or more other such documents, such combination being obvious to a person skilled in the art.<br>"&" document member of the same patent family |
| "A" document defining the general state of the art which is not considered to be of particular relevance<br>"E" earlier document but published on or after the international filing date<br>"L" document which may throw doubts on priority claim(s) or which is cited to establish the publication date of another citation or other special reason (as specified)<br>"O" document referring to an oral disclosure, use, exhibition or other means<br>"P" document published prior to the international filing date but later than the priority date claimed  | "T" later document published after the international filing date or priority date and not in conflict with the application but cited to understand the principle or theory underlying the invention<br>"X" document of particular relevance; the claimed invention cannot be considered novel or cannot be considered to involve an inventive step when the document is taken alone<br>"Y" document of particular relevance; the claimed invention cannot be considered to involve an inventive step when the document is combined with one or more other such documents, such combination being obvious to a person skilled in the art.<br>"&" document member of the same patent family |   |   |   |
| Date of the actual completion of the international search<br><br><p style="text-align: center;">5 March 1999</p>   |   | Date of mailing of the international search report<br><br><p style="text-align: center;">15/03/1999</p> |   |   |
| Name and mailing address of the ISA<br>European Patent Office, P.B. 5818 Patentlaan 2<br>NL - 2280 HV Rijswijk<br>Tel. (+31-70) 340-2040, Tx. 31 651 epo nl,<br>Fax: (+31-70) 340-3016   |   | Authorized officer<br><br><p style="text-align: center;">Leouffre, M</p>                                |   |   |

**INTERNATIONAL SEARCH REPORT**

Information on patent family members

International Application No  
PCT/US 98/25034

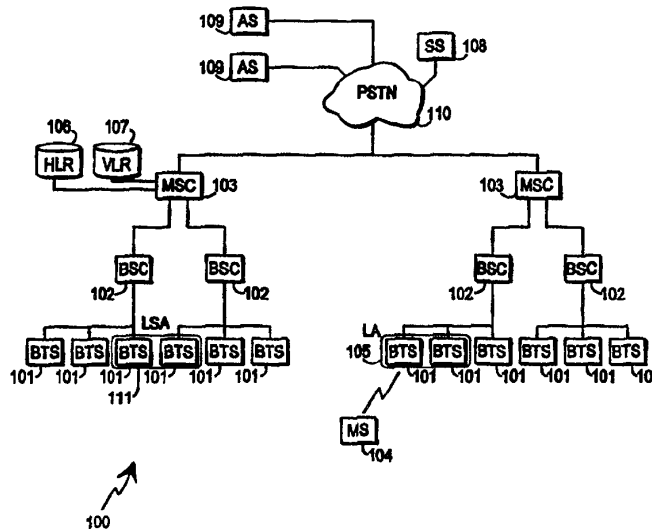
| Patent document cited in search report |   | Publication date | Patent family member(s)                                      | Publication date                                     |
|--|---|------------------|--|--|
| US 5485163                             | A | 16-01-1996       | CN 1125983 A<br>EP 0706664 A<br>JP 8511408 T<br>WO 9527219 A | 03-07-1996<br>17-04-1996<br>26-11-1996<br>12-10-1995 |
| EP 0600162                             | A | 08-06-1994       | DE 4240578 A   | 23-06-1994   |
| US 5748148                             | A | 05-05-1998       | AU 7113796 A<br>WO 9713160 A                                 | 28-04-1997<br>10-04-1997                             |
| DE 29705537                            | U | 06-11-1997       | NONE   |  |



INTERNATIONAL APPLICATION PUBLISHED UNDER THE PATENT COOPERATION TREATY (PCT)

|  |   |  |
|--|---|--|
| <p>(51) International Patent Classification <sup>6</sup> :<br/>H04Q 7/38</p>   | <p>A1</p>   | <p>(11) International Publication Number: <b>WO 99/52316</b><br/>(43) International Publication Date: 14 October 1999 (14.10.99)</p> |
| <p>(21) International Application Number: PCT/FI99/00227<br/>(22) International Filing Date: 23 March 1999 (23.03.99)<br/>(30) Priority Data:<br/>980654 23 March 1998 (23.03.98) FI<br/>(71) Applicant (for all designated States except US): NOKIA TELECOMMUNICATIONS OY [FI/FI]; P.O. Box 300, FIN-00045 Nokia Group (FI).<br/>(72) Inventor; and<br/>(75) Inventor/Applicant (for US only): PUTKIRANTA, Petteri [FI/FI]; Kelkkämäentie 12, FIN-02610 Espoo (FI).<br/>(74) Agent: BERGGREN OY AB; P.O. Box 16, FIN-00101 Helsinki (FI).</p> | <p>(81) Designated States: AE, AL, AM, AT, AU, AZ, BA, BB, BG, BR, BY, CA, CH, CN, CU, CZ, DE, DK, EE, ES, FI, GB, GD, GE, GH, GM, HR, HU, ID, IL, IN, IS, JP, KE, KG, KP, KR, KZ, LC, LK, LR, LS, LT, LU, LV, MD, MG, MK, MN, MW, MX, NO, NZ, PL, PT, RO, RU, SD, SE, SG, SI, SK, SL, TJ, TM, TR, TT, UA, UG, US, UZ, VN, YU, ZA, ZW, ARIPO patent (GH, GM, KE, LS, MW, SD, SL, SZ, UG, ZW), Eurasian patent (AM, AZ, BY, KG, KZ, MD, RU, TJ, TM), European patent (AT, BE, CH, CY, DE, DK, ES, FI, FR, GB, GR, IE, IT, LU, MC, NL, PT, SE), OAPI patent (BF, BJ, CF, CG, CI, CM, GA, GN, GW, ML, MR, NE, SN, TD, TG).</p> <p><b>Published</b><br/>With international search report.<br/>Before the expiration of the time limit for amending the claims and to be republished in the event of the receipt of amendments.<br/>In English translation (filed in Finnish).</p> |  |

(54) Title: METHOD AND SYSTEM FOR EXPLOITING LOCATION-DEPENDENT SERVICES IN A CELLULAR RADIO SYSTEM



(57) Abstract

A communications system (100, 300) comprises base stations (101) for providing mobile stations (104) with communications links. It comprises at least one localized service area (111) and means (108, 109) for changing the service selection offered to a given mobile station on the initiative of the communications system. The change is realized in response to information (203) indicating the arrival of the mobile station in said localized service area.

**FOR THE PURPOSES OF INFORMATION ONLY**

Codes used to identify States party to the PCT on the front pages of pamphlets publishing international applications under the PCT.

|    |                          |    |  |    |  |    |                          |
|----|--------------------------|----|--|----|--|----|--------------------------|
| AL | Albania                  | ES | Spain                                    | LS | Lesotho                                      | SI | Slovenia                 |
| AM | Armenia                  | FI | Finland                                  | LT | Lithuania                                    | SK | Slovakia                 |
| AT | Austria                  | FR | France                                   | LU | Luxembourg                                   | SN | Senegal                  |
| AU | Australia                | GA | Gabon                                    | LV | Latvia                                       | SZ | Swaziland                |
| AZ | Azerbaijan               | GB | United Kingdom                           | MC | Monaco                                       | TD | Chad                     |
| BA | Bosnia and Herzegovina   | GE | Georgia                                  | MD | Republic of Moldova                          | TG | Togo                     |
| BB | Barbados                 | GH | Ghana                                    | MG | Madagascar                                   | TJ | Tajikistan               |
| BE | Belgium                  | GN | Guinea                                   | MK | The former Yugoslav<br>Republic of Macedonia | TM | Turkmenistan             |
| BF | Burkina Faso             | GR | Greece                                   | ML | Mali   | TR | Turkey                   |
| BG | Bulgaria                 | HU | Hungary                                  | MN | Mongolia                                     | TT | Trinidad and Tobago      |
| BJ | Benin                    | IE | Ireland                                  | MR | Mauritania                                   | UA | Ukraine                  |
| BR | Brazil                   | IL | Israel                                   | MW | Malawi                                       | UG | Uganda                   |
| BY | Belarus                  | IS | Iceland                                  | MX | Mexico                                       | US | United States of America |
| CA | Canada                   | IT | Italy                                    | NE | Niger  | UZ | Uzbekistan               |
| CF | Central African Republic | JP | Japan                                    | NL | Netherlands                                  | VN | Viet Nam                 |
| CG | Congo                    | KE | Kenya                                    | NO | Norway                                       | YU | Yugoslavia               |
| CH | Switzerland              | KG | Kyrgyzstan                               | NZ | New Zealand                                  | ZW | Zimbabwe                 |
| CI | Côte d'Ivoire            | KP | Democratic People's<br>Republic of Korea | PL | Poland                                       |    |                          |
| CM | Cameroon                 | KR | Republic of Korea                        | PT | Portugal                                     |    |                          |
| CN | China                    | KZ | Kazakstan                                | RO | Romania                                      |    |                          |
| CU | Cuba                     | LC | Saint Lucia                              | RU | Russian Federation                           |    |                          |
| CZ | Czech Republic           | LI | Liechtenstein                            | SD | Sudan  |    |                          |
| DE | Germany                  | LK | Sri Lanka                                | SE | Sweden                                       |    |                          |
| DK | Denmark                  | LR | Liberia                                  | SG | Singapore                                    |    |                          |
| EE | Estonia                  |    |  |    |  |    |                          |

## METHOD AND SYSTEM FOR EXPLOITING LOCATION-DEPENDENT SERVICES IN A CELLULAR RADIO SYSTEM

The invention relates in general to the provision and delivery of services offered by a network to a mobile station. In particular the invention relates to the utilization of  
5 information concerning the location of a mobile station for the purpose of providing services.

A modern communications network provides mobile station owners with individual programmable services. A digital telephone network is one such network. Services known to be provided by it include programmable call transfer and voice mail system,  
10 which usually are implemented at a switching center. Networks are also known in which certain services are provided by an outside service provider who pays to the communications network operator for the use of their network, and the services provided by said service provider are located physically elsewhere than at switching centers. This patent application uses a digital cellular radio system as an example of  
15 a communications network.

In known networks the provision of services has not depended on the part of the network the user is located in when he places a call to an apparatus or equipment providing a service. According to a recent proposal, however, different locations can be specified for a mobile station in a network. Then, as a mobile station is registered in a cell, the service that it receives may be different according to its location.  
20 However, it would be advantageous in various situations if different services could be offered to the user according to his physical location on the initiative of the network, without the mobile station actually establishing a connection to the network. Such services are called network initiated services, and they include so-called  
25 push services in which an apparatus connected to the network sends data to mobile stations without the mobile stations requesting said information. An example of a locally arranged push service which cannot be implemented using prior-art solutions is to send the day's menu at a cafeteria of a company to the mobile stations of all those employees who are within the premises of the company as lunchtime is  
30 approaching.

An object of the present invention is to provide a method and system for making services provided by a network available to the user in various ways depending on the location of the user.

The objects of the invention are achieved by storing in the memory of the mobile station the information on the basis of which it recognizes that it is situated in a given localized service area and by programming the mobile station such that in response to such recognition it sends an appropriate message to an apparatus that provides services.

The invention pertains to a communications system that comprises base stations to provide mobile stations with communications links. It is characterized in that it comprises at least one localized service area and means for changing the service selection offered to a given mobile station on the initiative of the communications system in response to an indication that the mobile station has arrived in said localized service area.

The invention also pertains to a cellular mobile station that comprises a control block and storage means. It is characterized in that its storage means are adapted so as to store the information required to recognize a given localized service area whereby the mobile station is arranged so as to send – in response to the recognition of a localized service area – a notification of its arrival in the localized service area, said notification being intended to function as an impulse for changing the service selection offered to the mobile station.

The invention further pertains to a method for changing the service selection offered to a mobile station in a communications system that comprises base stations for providing mobile stations with communications links. The method is characterized in that it comprises steps in which

- information is generated about the arrival of a mobile station in a localized service area, and
- the service selection offered to said mobile station on the initiative of the communications system is changed.

In accordance with the invention, localized service areas (LSA) are defined for mobile stations, which areas may be purely geographical or may have some other criteria. In addition to or instead of the geographical definition a localized service area may be defined e.g. in chronological terms. "Geographical definition" means generally definitions associated with a place or area: a localized service area may comprise a base station cell, several cells, a location area (LA), a public land mobile network (PLMN), an area defined by coordinates, certain cell identifiers, or an area in which base stations send to mobile stations some other identifier. Combinations of these alternatives may be used, too.



Information about how a mobile station can recognize that it is in a given localized service area is stored in the memory of the mobile station. Since services are usually in a way or another associated with the subscription contract in which the user is given certain user-specific rights to use the communications network, it is preferable to store the information relating to the recognition of a localized service area in the user's SIM (subscriber identity module) card or a corresponding memory means intended specifically for the identification of the user independent of the apparatus used. In response to a positive identification the user's mobile station sends a message addressed to an apparatus responsible for providing localized services in the network. With this message the mobile station tells that the user is in a certain localized service area. On the basis of the message the network can offer to the user just those services that are needed in that localized service area. When the mobile station moves elsewhere, it sends a similar message telling that it is leaving the localized service area. The network may also automatically deduce that the mobile station has left the area as a certain condition is met. Such conditions include e.g. that

- the mobile station does not respond to the next paging message or another message sent in the localized service area in question,
- the mobile station does not acknowledge a data packet addressed to it,
- the mobile station does not in a certain period of time renew its message of arrival in the localized service area, or
- the mobile station does not in a certain period of time send another message that must be sent periodically, such as the periodic location update (PLU) message, for example.

The apparatus, to which the mobile station addresses its location message, may be maintained by the network operator or a service provider. The message may be an SMS (Short Message Service) message, an unstructured supplementary service data (USSD) message, a DTMF-coded (Dual Tone Multi-Frequency) message sent in conjunction with an ordinary call, or a data call. In response to the message the apparatus, to which the mobile station addresses its location message, may e.g. send information about the area in question to the mobile station or start the regular or periodic sending of such information, which goes on until the mobile station leaves the localized service area. Furthermore, the apparatus providing the services may activate or inactivate another localized service, send information about the location of the mobile station to other apparatus which need that information in their operation, or carry out some other function. One option is that mobile stations are assigned certain localized service profiles which may comprise various factors from

call pricing to data rates of data calls or to priorities of call establishment and management. The application of the service profile is in that case based on the location of the mobile station in a given localized service area.

The invention is below described in more detail with reference to the preferred embodiments presented by way of example and to the accompanying drawing in which

- Fig. 1 shows a communications system according to the invention,  
Fig. 2 illustrates the exchange of messages in the communications system according to Fig. 1,  
Fig. 3 shows a second communications system according to the invention,  
10 Fig. 4 shows a mobile station according to the invention, and  
Fig. 5 shows an embodiment of the method according to the invention.

Fig. 1 shows a cellular radio system 100 which in a known manner comprises base transceiver stations (BTS) 101, base station controllers (BSC) 102 and mobile switching centers (MSC) 103. A mobile station (MS) 104 is connected via radio to at least one base transceiver station 101 so that the system considers the mobile station to be located in that location area (LA) 105 to which the coverage area, or cell, of that particular base transceiver station belongs. A location area may comprise one or more cells. For the purpose of maintaining location data of mobile stations and routing calls the system includes home location registers (HLR) 106 and visitor location registers (VLR) 107 which usually are located at mobile switching centers. In the system according to Fig. 1 a service server (SS) 108 and application servers (AS) 109 are also connected to the cellular radio network through wire links. Connections from the cellular radio network to servers 108 and 109 may be either direct, in which case the servers are in a way part of the cellular radio system, or routed via the public switched telephone network (PSTN) 110. Direct connections will be used mainly when servers 108 and 109 are maintained by the same operator who is responsible for the operation of the cellular radio system.

A prerequisite for the operation according to the invention is that somehow a piece of information is generated indicating that a mobile station is located in a certain designated localized service area 111. As was mentioned above, a localized service area may be the same as a given location area but nothing prevents from defining localized service areas completely differently; in Fig. 1 the localized service area 111 includes base transceiver stations under two different base station controllers. According to a first embodiment of the invention, however, a service area always comprises a certain cell or certain cells. If the coverage area of a base transceiver

station can by means of directional antennas be divided into cells or blocks smaller than the central cell around the base transceiver station such that the system can make a logical distinction between those cells or blocks, then these smaller areas can also be utilized in defining the localized service area. The information about the location of a mobile station in a service area can then be generated either at the mobile station, which is regarded as the more preferable embodiment, or in fixed parts of the system. A limitation of the latter option is that since known cellular radio systems maintain mobile station location data only with the accuracy of a location area, defining a localized service area smaller than one location area would call for changes in the operation of the system.

Let us then assume that the information about the location of a mobile station in a localized service area is generated at the mobile station itself. To that end there exist several known methods which usually are based on the fact that every base transceiver station in known cellular radio systems sends general control information that can be received in the whole cell area and which e.g. comprises the unequivocal identifier of the base transceiver station or some other information characteristic of the base transceiver station. A method for detecting base station specific identifiers has been stored in advance in the mobile station. In the simplest case the memory of the mobile station stores a list of the identifiers of the base transceiver stations the cells of which make a particular localized service area. By comparing the received identifier with the list in the memory the mobile station finds out whether it is located in a certain localized service area. According to an alternative embodiment only a certain mask is stored in the memory of the mobile station so that the mobile station uses the mask to select certain characters from the base station specific identifier to be examined. If the characters examined form or follow a certain pattern the base station cell belongs to a localized service area. An advantage of this embodiment is that if the communications capacity of the localized service area is increased by establishing a new base station in the area, there is no need to separately send the identifier of the new base station to each mobile station to which the localized service area has been assigned; it suffices that the masked characters in the new base station identifier are the same as or corresponding to those of the other base stations in that localized service area.

According to a second embodiment of the invention a localized service area is not associated with base station cells but has certain geographic coordinates. In this embodiment a mobile station may detect that it is in a given service area e.g. in such a manner that each base station sends together with the general control information

information about the location of the base station in a geographic coordinate system. Having received the coordinates the mobile station may examine whether the point indicated by the coordinates is located within a localized service area assigned to the mobile station. In a more versatile method the mobile station may receive co-  
5 ordinates from all the base stations from which it can receive general control information, and assume that its own location is the average of the coordinates received. By comparing the location it has computed with the stored geographic definition of the localized service area the mobile station detects whether or not it is in the local-  
10 ized service area. Future mobile stations may include a GPS (Global Positioning System) receiver or some other means completely independent of base stations to determine the location of the mobile station in a geographic coordinate system. This makes it possible to define a localized service area completely independent of the cellular radio system cells.

According to a third embodiment of the invention, temporal dimension is also in-  
15 cluded in the definition of a localized service area. If a cellular radio system comprises cells A, B, C, D and E, it can be defined that a given localized service area comprises at all times cells A and B, but cell C only between 12 and 3 o'clock in the afternoon, and cells D and E on Wednesday, Friday and Saturday from 6 p.m. till 3 a.m. in the next morning. Naturally the temporal dimension may also be combined  
20 with the cell-independent geographic definition described above.

Fig. 2 assumes that the information about the location of a mobile station in a given service area is generated at the mobile station on the basis of a base station specific identifier received by the mobile station from the base station. The figure illustrates in a simplified manner the exchange of messages relating to the operation according  
25 to a preferred embodiment of the invention between a mobile station 104, base transceiver station 101, service server 108 and application server 109. The messages are depicted by arrows and their chronological order is from top down. Message 201 is a known general control information message sent by the base station to the mobile station, comprising a base station specific identifier. General information  
30 messages include e.g. information sent by base stations on the broadcast control channel (BCCH) in the GSM system. Block 202 refers to the comparison at the mobile station with an identifier list, or some other activity on the basis of which the mobile station detects that it has arrived in a certain localized service area. In response to that observation the mobile station sends to the service server a message  
35 203 in which it includes an identifier characteristic of the mobile station, say an IMSI (International Mobile Subscriber Identifier) code or MS-ISDN (Mobile Sub-

scriber Integrated Services Digital Network) number stored in the SIM card of the mobile station.

5 The invention does not limit the form of message 203. One advantageous option is to use an SMS message such that the mobile station reads from the memory the phone number of the service server and sends the SMS message to that number. A second option is to use a free-form data message specified in many digital cellular radio systems; in the GSM it is called an USSD message. The mobile station may also by itself establish a call connection to the service server and send the message 203 DTMF-coded or as a data call.

10 The role of the service server in the embodiment according to Fig. 2 is to maintain information about which mobile stations are in which localized service areas and which services should be offered to them accordingly. The actual service is provided by the application server. Having received message 203 the service server reads from its memory which services should be offered to the mobile station in that  
15 localized service area and sends a service request 204 to the appropriate application server. The information about what services are provided by which application servers is also stored in the memory of the service server so that it can send the service request 204 to the correct application server. The invention does not limit the form of the service request 204. From the prior art it is known several methods  
20 for realizing communication between two servers connected to a communications network.

In response to a service request 204 the application server provides the mobile station with a service, indicated in Fig. 2 simply by an arrow 205. The service is not necessarily a simple message and its commencement does not necessarily involve  
25 only information sent to the mobile station. A mobile station may have a whole service profile defined for it in a localized service area, including e.g.

- call pricing or prioritization,
- limitations concerning the modulation method, data rate and/or connection quality in the communication between the base station and mobile station,
- 30 - routing of incoming email messages to a mobile station instead of the user's desktop workstation, or
- activation or inactivation of automatic call transfer and/or voice mail service.

The mobile station may also have the right or obligation in a given localized service area to receive messages periodically e.g. with regard to the weather, traffic, stock  
35 exchange rates and so on. Thus the application server may at the stage represented

by arrow 205 establish connections in a versatile manner with various apparatus in the cellular radio system or in communication with the cellular radio system. On the other hand, the service server may have instructions stored in its memory to request services from more than one application server, in which case there would be several messages 204 sent to a plurality of application servers.

Fig. 2 further assumes that the mobile station leaves the localized service area in accordance with controlled cell reselection in which case it sends to the service server a notification 206 about its departure from the service area. In response to the departure message the service server sends to the application server a request 207 to terminate the service. The mobile station can send message 206 via the old base station always when leaving a cell belonging to the localized service area regardless of whether the new cell belongs to the same localized service area. In an alternative embodiment the mobile station checks always after a cell reselection whether it is still in the same localized service area, and if not, it sends via the new base station a notification about its departure to the service server. According to a second alternative embodiment mobile stations do not send departure messages at all but the departure of a mobile station from a given localized service area is detected by fixed parts of the system e.g. when a mobile station will not respond to a paging message or another message sent to it in that localized service area, or will not send the specified periodic location update message or some other mandatory periodic notification, or when the service server sends regularly or periodically to all mobile stations in a localized service area a short data message which must be acknowledged by the mobile stations; a failure to acknowledge the message indicates that the mobile station in question is no more in the localized service area.

Above it was disclosed that in a given localized service area a mobile station receives a certain service. However, service areas may be defined which are characterized in that a mobile station will not be offered a service that it would receive elsewhere. A mobile station may be assigned several service areas with different operating instructions for the different areas. The service server which the mobile station informs about its arrival in a localized service area may be always the same or different in some localized service areas. Alone the fact that whether or not a mobile station indicates its arrival in a localized service area and if so, how quickly it does it, may depend on the service area. The user may be given a choice about whether or not to give notification about his arrival in a localized service area. The mobile station may even inform the user that he has now arrived in a localized service area and ask for permission to send the notification of arrival. In connection

with the request for permission the user may be given a short description of the consequences of sending the notification of arrival. On the other hand, certain localized service areas may be defined by the network operator such that the notification of arrival is compulsory, whereby a mobile station has to send a notification of arrival every time that it arrives in such a localized service area regardless of what the user instructs the mobile station to do.

Above it was disclosed that the service server and application server are separate apparatus. However, these functions can be integrated in one device, whereby the communication between the servers as described above is reduced to communication internal to a server. One or both of them may also be implemented in connection with a known apparatus that already belongs to the cellular radio system. Servers can advantageously be integrated in mobile switching centers or base station controllers.

Fig. 3 shows a communications system 300 according to the invention, in which a localized cellular service (LCS) 302 operates under a public land mobile network (PLMN) 301 in an area with a high traffic density; the mobile switching center maintaining the service is called an LCS switching center (LCS-SC) 303. The LCS-SC operates just like a prior-art mobile switching center. It provides for the internal communication of the LCS and establishes, maintains and terminates connections between terminal equipment in the LCS and elsewhere. In connection with the LCS-SC there is a visitor location register 304 and a combined service and application server 305, which is called simply a server. In this embodiment of the invention the localized service area 306 covers all base stations operating under the LCS-SC (for simplicity, the base station controllers are not shown). Unlike above, the observation that a given mobile station has arrived in the localized service area is made in the fixed parts of the network, more specifically in the visitor location register 304. Let the cellular subsystem shown in Fig. 3 operate at an airport. Airline companies can provide the visitor location register 304 with the mobile phone numbers or other identifiers of their customers to whom certain benefits have been granted on the basis of their being frequent flyers, for example. As the visitor location register 304 detects that a mobile station associated with such an identifier has arrived in the area of the cellular subsystem, it sends appropriate information to the server 305. Instead of or in addition to the visitor location register other fixed network apparatus may take part in the sending of the message. In response to this information the server 305 starts sending to the mobile station announcements which are intended

only to privileged customers of the airline companies. The announcements are advantageously delivered as SMS messages.

In known digital telephone systems the sending of SMS messages is carried out via SMS service centers and not directly from an apparatus to another. However, for simplicity the SMS service centers are not included in the description above but their use is considered to be known to a person skilled in the art. Other messages described above may also be sent between apparatus via various known intermediary devices.

Fig. 4 shows simplified a control block and some memory parts of a mobile station according to the invention. The control block 401 is preferably a microprocessor which is located in the mobile station in a known manner such that data received by the mobile station, except for data intended to be presented directly to the user, is conducted from the receiver chain RX to the control block and, correspondingly, outgoing data produced by the control block is conducted to the transmitter chain TX of the mobile station together with the data coming directly from the user (say, digitized speech). In the mobile station according to Fig. 4 the control block has access to a fixed memory 402 and a removable memory unit 403, which is e.g. a smart card. The control block 401 also receives input from a keypad 404 and it outputs information on a display 405. A program executed by the control block 401 is stored in the fixed memory 402. Part of that program is an instruction to look for program extensions in the removable memory unit 403. For the operation according to the invention the removable memory unit includes a program 406 by means of which the mobile station is able to utilize localized service areas, as well as information 407, 408 about at least one localized service area (LSA1, LSA2). Fig. 4 assumes that the recognition of a localized service area is based on the mobile station comparing received base transceiver station identifiers (BTS ID) with a list of localized service areas stored in the memory. For each localized service area the removable memory unit 403 also includes a service server identifier (SS ID).

Fig. 5 illustrates the principle of a method according to a preferred embodiment of the invention in a mobile station, service server and application server. In accordance with block 501 the mobile station detects a cell reselection. It examines, block 502, whether any changes are occurring with respect to localized service areas, i.e. whether it is arriving in a localized service area (if until now it wasn't in one) or if it is leaving a localized service area (if until now it was in one). In accordance with block 503 the change triggers the sending of a message to a service server the operation of which starts from the reception of the message, block 504.



According to block 505 the service server examines whether the mobile station in question is on the list of those to be served. If the mobile station is arriving in a localized service area, it is in block 505 recognized as a mobile station which is to be served. If, on the other hand, the mobile station is leaving a localized service area, it is recognized in block 505 as a mobile station the services to which have to be terminated. A corresponding message is sent according to block 506 to an application server which receives the message in block 507 and determines in block 508 whether the message calls for the starting or termination of a service. The service is then either started 509 or terminated 510 for the mobile station, whichever the case may be.

The embodiments of the invention described above are naturally examples only and do not limit the invention. Communications systems, to which the invention can be advantageously applied, include e.g. second-generation digital mobile phone systems such as the GSM and its extensions, PDC (Personal Digital Cellular), D-AMPS (Digital Advanced Mobile Phone System) and PCS (Personal Communications Services) and future third-generation digital cellular radio systems such as the UMTS (Universal Mobile Telecommunications System) and IMT-2000 (International Mobile Telecommunications at 2000 MHz).

### Claims

1. A communications system (100, 300) comprising base stations (101) for providing mobile stations (104) with communications links, **characterized** in that it comprises at least one localized service area (111) and means (108, 109) for  
5 changing the service selection offered to a mobile station on the initiative of the communications system in response to an indication of the arrival of the mobile station in said localized service area.
2. A communications system according to claim 1, **characterized** in that it comprises a service server (108) to maintain information concerning the location of  
10 mobile stations in localized service areas and to generate requests for changing the service selection offered to mobile stations, and an application server (109) to provide mobile stations with different services in response to a request generated by the service server for changing the service selection.
3. A communications system according to claim 2, **characterized** in that said  
15 service server is the same as said application server.
4. A communications system according to claim 1, **characterized** in that it is adapted so as to change a localized service selection offered to a mobile station in response to a notification (203) sent by the mobile station on its arrival in a localized service area.
- 20 5. A communications system according to claim 1, **characterized** in that it is adapted so as to detect the arrival of a mobile station in a localized service area without the mobile station sending a special notification of its arrival in the localized service area.
- 25 6. A cellular mobile station comprising a control block (401) and memory means (402, 403), **characterized** in that said memory means are adapted so as to store the information (407, 408) required for recognizing a localized service area, whereby the mobile station is adapted so as to send a notification (203) of its arrival in the localized service area in response to the recognition of the localized service area, said notification being intended as an impulse for changing the service selection  
30 offered to the mobile station.
7. A mobile station according to claim 6, **characterized** in that said memory means is located in a removable memory unit (403).

8. A method for changing the service selection offered to a mobile station in a communications system that comprises base stations for providing mobile stations with communications links, **characterized** in that it comprises steps in which
- information is generated about the arrival of a mobile station in a localized service area (203), and
  - the service selection offered to said mobile station on the initiative of the communications system is changed (205).
9. A method according to claim 8, **characterized** in that the information about the arrival of a mobile station in a localized service area is generated by receiving from the mobile station a message (203) indicating that the mobile station has detected that it is in the localized service area.
10. A method according to claim 8, **characterized** in that the information about the arrival of a mobile station in a localized service area is generated by comparing mobile station identifiers with a list of identifiers in a register (304) listing mobile stations to which the localized service area in question has been designated.
11. A method according to claim 10, **characterized** in that said comparison is performed in a certain register (304) and said changing of the service selection offered to a mobile station on the initiative of the communications system is performed in a second apparatus (305) in the communications system when the information about the result of the comparison has been sent from said register (304) to said second apparatus (305) in the communications system.
12. A method according to claim 8, **characterized** in that in response to the information about the arrival of a mobile station in a localized service area a predetermined additional service is offered to the mobile station.
13. A method according to claim 12, **characterized** in that said additional service involves the sending of announcements to the mobile station.
14. A method according to claim 8, **characterized** in that in response to the information about the arrival of a mobile station in a localized service area the quantity of services offered to the mobile station on the initiative of the communications system is reduced.
15. A method according to claim 8, **characterized** in that it is comprised of steps where

- a message (203) indicating the arrival of a mobile station in a localized service area is communicated to a service server (108),
  - it is checked what services should be offered to the mobile station in that localized service area,
- 5
- a request (204) for the services to be offered is communicated to an application server (109) providing the services, and
  - a service (205) produced by the application server is provided to the mobile station.
16. A method according to claim 15, **characterized** in that it is comprised of steps
- 10 where
- the request for the services to be offered is sent to at least two application servers providing services, and
  - a service produced by every application server, to which the request for the services to be offered was made, is provided to the mobile station.

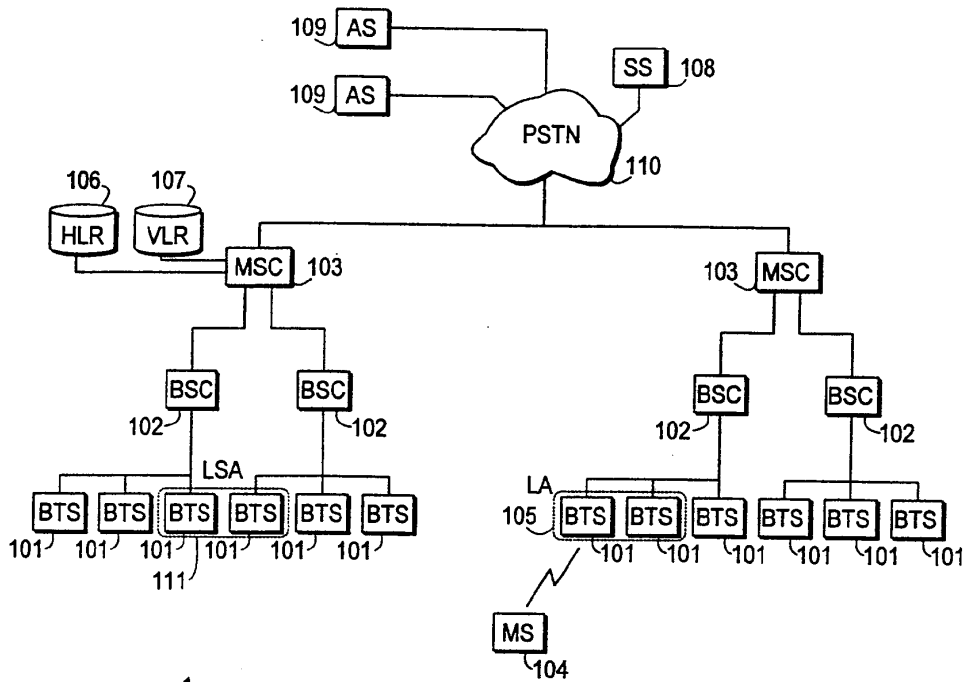


Fig. 1

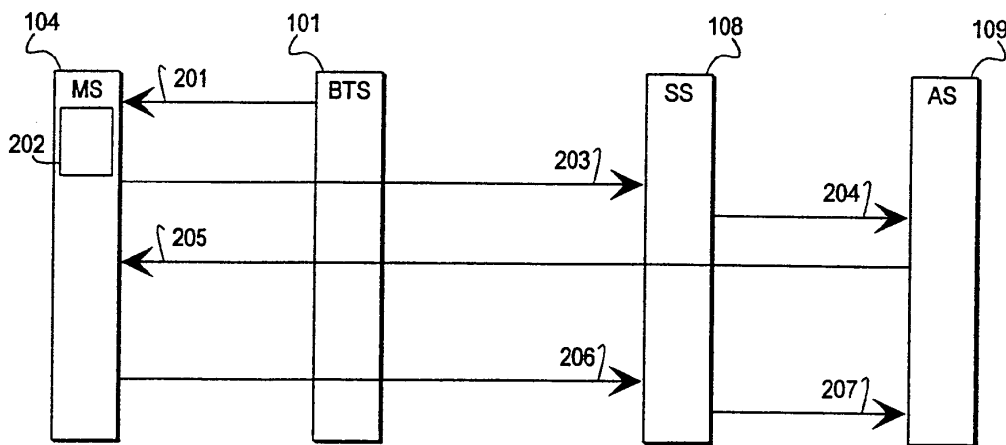


Fig. 2

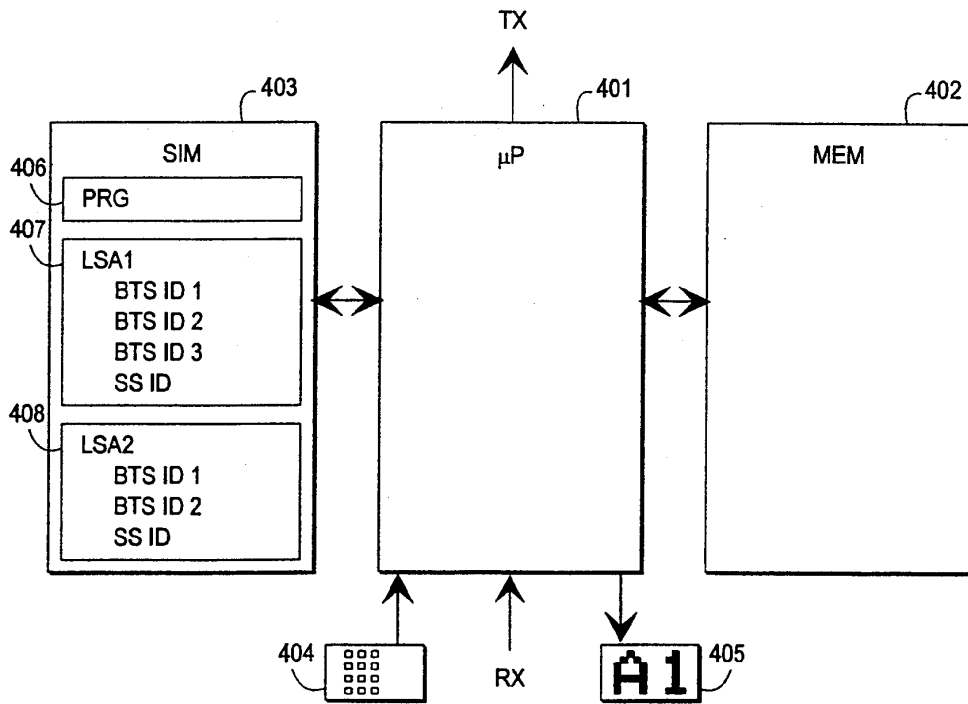
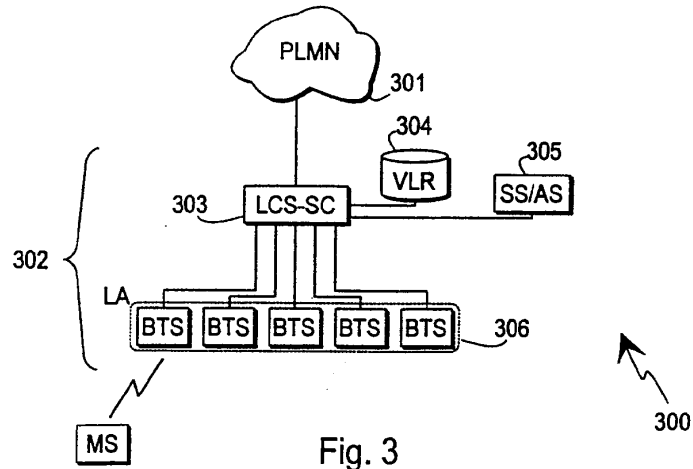


Fig. 4

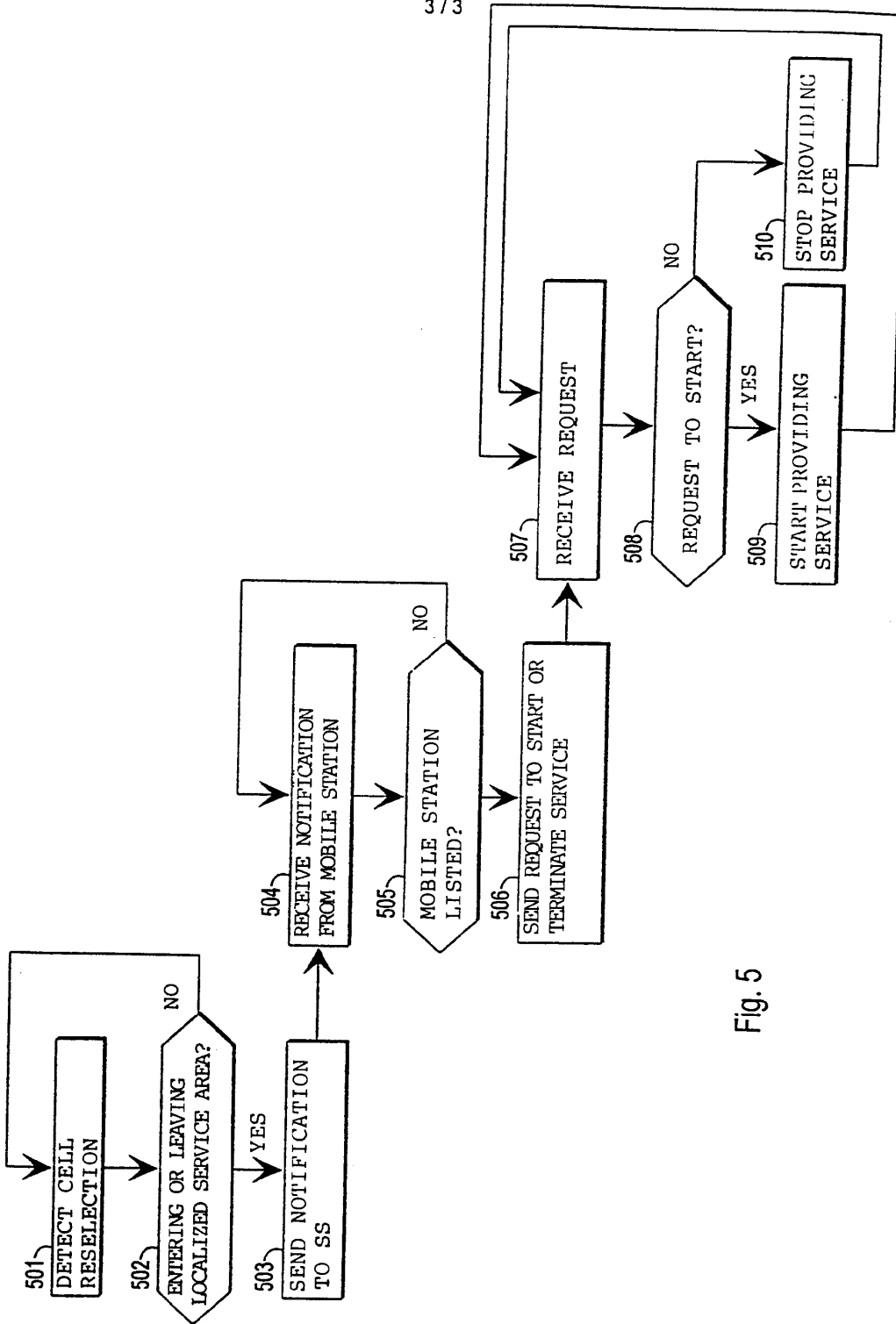


Fig. 5

## INTERNATIONAL SEARCH REPORT

International application No.

PCT/FI 99/00227

| <b>A. CLASSIFICATION OF SUBJECT MATTER</b>  |   |  |
|---|---|--|
| IPC6: H04Q 7/38<br>According to International Patent Classification (IPC) or to both national classification and IPC  |   |  |
| <b>B. FIELDS SEARCHED</b>   |   |  |
| Minimum documentation searched (classification system followed by classification symbols)   |   |  |
| IPC6: H04Q  |   |  |
| Documentation searched other than minimum documentation to the extent that such documents are included in the fields searched   |   |  |
| SE,DK,FI,NO classes as above  |   |  |
| Electronic data base consulted during the international search (name of data base and, where practicable, search terms used)  |   |  |
| <b>C. DOCUMENTS CONSIDERED TO BE RELEVANT</b>   |   |  |
| Category*   | Citation of document, with indication, where appropriate, of the relevant passages  | Relevant to claim No.  |
| X   | FR 2711033 A1 (COMPAGNIE FINANCIERE POUR LE RADIOTELEPHONE (COFIRA)(S.A.)), 14 April 1995 (14.04.95), page 1, line 11 - line 19, abstract     | 1,8,12   |
| A   | page 10, line 10 - page 11, line 28, figures 1,2<br>--  | 2-4,9,14,15  |
| X   | CA 2195487 A1 (AT&T WIRELESS SERVICES, INC.), 20 August 1997 (20.08.97), page 2, line 21 - line 28; page 6, line 17 - line 21, abstract<br>-- | 1,4,8,12,13,14   |
| <input checked="" type="checkbox"/> Further documents are listed in the continuation of Box C. <input checked="" type="checkbox"/> See patent family annex.   |   |  |
| * Special categories of cited documents:<br>"A" document defining the general state of the art which is not considered to be of particular relevance<br>"B" earlier document but published on or after the international filing date<br>"L" document which may throw doubts on priority claim(s) or which is cited to establish the publication date of another citation or other special reason (as specified)<br>"O" document referring to an oral disclosure, use, exhibition or other means<br>"P" document published prior to the international filing date but later than the priority date claimed<br>"I" later document published after the international filing date or priority date and not in conflict with the application but cited to understand the principle or theory underlying the invention<br>"X" document of particular relevance: the claimed invention cannot be considered novel or cannot be considered to involve an inventive step when the document is taken alone<br>"Y" document of particular relevance: the claimed invention cannot be considered to involve an inventive step when the document is combined with one or more other such documents, such combination being obvious to a person skilled in the art<br>"&" document member of the same patent family |   |  |
| Date of the actual completion of the international search   |   | Date of mailing of the international search report                     |
| 3 Sept 1999   |   | 07 -09- 1999   |
| Name and mailing address of the ISA/<br>Swedish Patent Office<br>Box 5055, S-102 42 STOCKHOLM<br>Facsimile No. +46 8 666 02 86  |   | Authorized officer<br>Peter Hedman/cs<br>Telephone No. +46 8 782 25 00 |

Form PCT/ISA/210 (second sheet) (July 1992)



## INTERNATIONAL SEARCH REPORT

International application No.

PCT/FI 99/00227

| C (Continuation). DOCUMENTS CONSIDERED TO BE RELEVANT |   |                       |
|---|---|-----------------------|
| Category*   | Citation of document, with indication, where appropriate, of the relevant passages                | Relevant to claim No. |
| X   | EP 0783235 A2 (AT&T CORP.), 9 July 1997 (09.07.97),<br>see the whole document                     | 1-5,8,10-12,<br>14,15 |
| Y   |   | 6,7,9                 |
| A   |   | 16                    |
|   | --  |                       |
| Y,E   | EP 0915631 A2 (NOKIA MOBILE PHONES LTD.), 12 May<br>1999 (12.05.99), see the whole document       | 6-7,9                 |
|   | --  |                       |
| A   | US 5603090 A (TUAN K. NGUYEN ET AL),<br>11 February 1997 (11.02.97), page 1,<br>line 38 - line 53 | 6,7,9                 |
|   | --<br>-----   |                       |

Form PCT/ISA/210 (continuation of second sheet) (July 1992)

**INTERNATIONAL SEARCH REPORT**  
Information on patent family members

02/08/99

International application No.  
PCT/FI 99/00227

| Patent document cited in search report | Publication date | Patent family member(s)                     | Publication date                 |
|--|------------------|---|----------------------------------|
| FR 2711033 A1                          | 14/04/95         | EP 0647076 A<br>FR 2711023 A,B              | 05/04/95<br>14/04/95             |
| CA 2195487 A1                          | 20/08/97         | NONE  |                                  |
| EP 0783235 A2                          | 09/07/97         | JP 9200836 A<br>US 5740538 A                | 31/07/97<br>14/04/98             |
| EP 0915631 A2                          | 12/05/99         | AU 8864998 A<br>FI 973456 A<br>WO 9911085 A | 16/03/99<br>23/02/99<br>04/03/99 |
| US 5603090 A                           | 11/02/97         | NONE  |                                  |

Form PCT/ISA/210 (patent family annex) (July 1992)



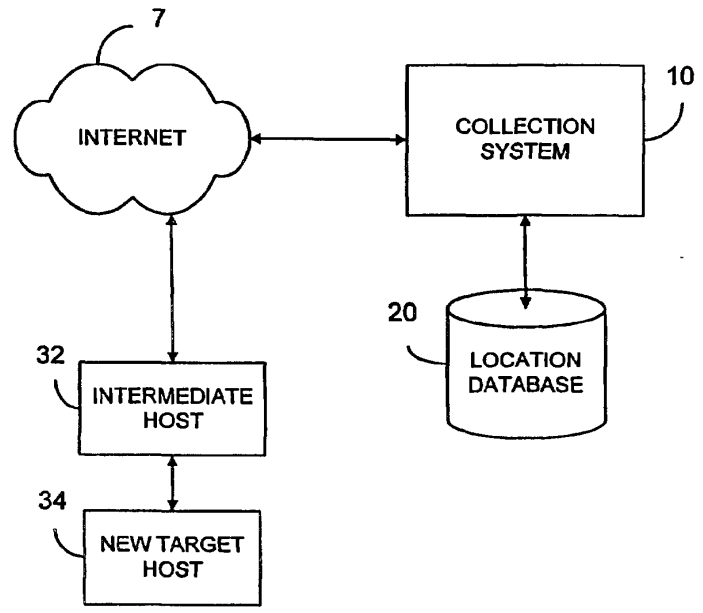
INTERNATIONAL APPLICATION PUBLISHED UNDER THE PATENT COOPERATION TREATY (PCT)

|  |  |  |
|--|--|--|
| <p>(51) International Patent Classification <sup>7</sup> :<br/><b>H04L 29/12, 29/06, 12/24</b></p>   | <p><b>A1</b></p>   | <p>(11) International Publication Number: <b>WO 00/67450</b><br/>(43) International Publication Date: 9 November 2000 (09.11.00)</p> |
| <p>(21) International Application Number: PCT/US00/11803<br/>(22) International Filing Date: 2 May 2000 (02.05.00)</p> <p>(30) Priority Data:<br/>60/132,147 3 May 1999 (03.05.99) US<br/>60/133,939 13 May 1999 (13.05.99) US<br/>09/541,451 31 March 2000 (31.03.00) US</p> <p>(71) Applicant: DIGITAL ENVOY, INC. [US/US]; Suite 100, 4500 River Green Parkway, Duluth, GA 30096 (US).</p> <p>(72) Inventors: PAREKH, Sanjay, M.; 3333 Willbridge Court, Duluth, GA 30096 (US). FRIEDMAN, Robert, B.; 1405 Crescent Walk, Decatur, GA 30033 (US). TIBREWALA, Neal, K.; 5523 Howe Street, Apt. 3, Pittsburgh, PA 15232 (US). LUTCH, Benjamin; 660 Leona Lane, Mountain View, CA 94040 (US).</p> <p>(74) Agents: PRATT, John, S. et al.; Kilpatrick Stockton LLP, Suite 2800, 1100 Peachtree Street, Atlanta, GA 30309-4530 (US).</p> | <p>(81) Designated States: AE, AG, AL, AM, AT, AU, AZ, BA, BB, BG, BR, BY, CA, CH, CN, CR, CU, CZ, DE, DK, DM, DZ, EE, ES, FI, GB, GD, GE, GH, GM, HR, HU, ID, IL, IN, IS, JP, KE, KG, KP, KR, KZ, LC, LK, LR, LS, LT, LU, LV, MA, MD, MG, MK, MN, MW, MX, NO, NZ, PL, PT, RO, RU, SD, SE, SG, SI, SK, SL, TJ, TM, TR, TT, TZ, UA, UG, UZ, VN, YU, ZA, ZW, ARIPO patent (GH, GM, KE, LS, MW, SD, SL, SZ, TZ, UG, ZW), Eurasian patent (AM, AZ, BY, KG, KZ, MD, RU, TJ, TM), European patent (AT, BE, CH, CY, DE, DK, ES, FI, FR, GB, GR, IE, IT, LU, MC, NL, PT, SE), OAPI patent (BF, BJ, CF, CG, CI, CM, GA, GN, GW, ML, MR, NE, SN, TD, TG).</p> <p><b>Published</b><br/><i>With international search report.</i><br/><i>Before the expiration of the time limit for amending the claims and to be republished in the event of the receipt of amendments.</i></p> |  |

(54) Title: SYSTEMS AND METHODS FOR DETERMINING, COLLECTING, AND USING GEOGRAPHIC LOCATIONS OF INTERNET USERS

(57) Abstract

A method of determining a geographic location of an Internet user involves determining if the host is on-line, determining ownership of the host name, and then determining the route taken in delivering packets to the user. Based on the detected route, the method proceeds with determining the geographic route based on the host locations and then assigning a confidence level to the assigned location. A system collects the geographic information and allows web sites or other entities to request the geographic location of their visitors. The database of geographic locations may be stored in a central location or, alternatively, may be at least partially located at the web site. With this information, web sites can target content, advertising, or route traffic depending upon the geographic locations of their visitors. Through web site requests for geographic information, a central database tracks an Internet user's traffic on the Internet whereby a profile can be generated. In addition to this profile, the central database can store visitor's preferences as to what content should be delivered to an IP address, the available interface, and the network speed associated with that IP address.



**FOR THE PURPOSES OF INFORMATION ONLY**

Codes used to identify States party to the PCT on the front pages of pamphlets publishing international applications under the PCT.

|    |                          |    |  |    |  |    |                          |
|----|--------------------------|----|--|----|--|----|--------------------------|
| AL | Albania                  | ES | Spain                                    | LS | Lesotho                                      | SI | Slovenia                 |
| AM | Armenia                  | FI | Finland                                  | LT | Lithuania                                    | SK | Slovakia                 |
| AT | Austria                  | FR | France                                   | LU | Luxembourg                                   | SN | Senegal                  |
| AU | Australia                | GA | Gabon                                    | LV | Latvia                                       | SZ | Swaziland                |
| AZ | Azerbaijan               | GB | United Kingdom                           | MC | Monaco                                       | TD | Chad                     |
| BA | Bosnia and Herzegovina   | GE | Georgia                                  | MD | Republic of Moldova                          | TG | Togo                     |
| BB | Barbados                 | GH | Ghana                                    | MG | Madagascar                                   | TJ | Tajikistan               |
| BE | Belgium                  | GN | Guinea                                   | MK | The former Yugoslav<br>Republic of Macedonia | TM | Turkmenistan             |
| BF | Burkina Faso             | GR | Greece                                   | ML | Mali   | TR | Turkey                   |
| BG | Bulgaria                 | HU | Hungary                                  | MN | Mongolia                                     | TT | Trinidad and Tobago      |
| BJ | Benin                    | IE | Ireland                                  | MR | Mauritania                                   | UA | Ukraine                  |
| BR | Brazil                   | IL | Israel                                   | MW | Malawi                                       | UG | Uganda                   |
| BY | Belarus                  | IS | Iceland                                  | MX | Mexico                                       | US | United States of America |
| CA | Canada                   | IT | Italy                                    | NE | Niger  | UZ | Uzbekistan               |
| CF | Central African Republic | JP | Japan                                    | NL | Netherlands                                  | VN | Viet Nam                 |
| CG | Congo                    | KE | Kenya                                    | NO | Norway                                       | YU | Yugoslavia               |
| CH | Switzerland              | KG | Kyrgyzstan                               | NZ | New Zealand                                  | ZW | Zimbabwe                 |
| CI | Côte d'Ivoire            | KP | Democratic People's<br>Republic of Korea | PL | Poland                                       |    |                          |
| CM | Cameroon                 | KR | Republic of Korea                        | PT | Portugal                                     |    |                          |
| CN | China                    | KZ | Kazakstan                                | RO | Romania                                      |    |                          |
| CU | Cuba                     | LC | Saint Lucia                              | RU | Russian Federation                           |    |                          |
| CZ | Czech Republic           | LI | Liechtenstein                            | SD | Sudan  |    |                          |
| DE | Germany                  | LK | Sri Lanka                                | SE | Sweden                                       |    |                          |
| DK | Denmark                  | LR | Liberia                                  | SG | Singapore                                    |    |                          |
| EE | Estonia                  |    |  |    |  |    |                          |

SYSTEMS AND METHODS FOR DETERMINING, COLLECTING, AND USING  
GEOGRAPHIC LOCATIONS OF INTERNET USERS

5                                   CROSS-REFERENCE TO RELATED APPLICATIONS

This application claims priority to, and incorporates by reference, U.S. Application Serial No. 60/132,147 entitled "System to Determine the Geographic Location of an Internet User" filed on May 3, 1999, and U.S. Application Serial No. 60/133,939 entitled "Method, System and Set of Programs for Tailoring an Internet Site Based Upon the Geographic  
10 Location or Internet Connection Speed of Internet User" filed on May 13, 1999.

FIELD OF THE INVENTION

The present invention relates to systems and methods for determining geographic  
15 locations of Internet users. According to other aspects, the invention relates to systems and methods for collecting geographic locations of Internet users, for profiling Internet users, or for selectively delivering information based on the geographic locations or connection speeds of the Internet users.

20                                   BACKGROUND

The Internet consists of a network of interconnected computer networks. Each of these computers has an IP address that is comprised of a series of four numbers separated by periods or dots and each of these four numbers is an 8-bit integer which collectively represent the unique address of the computer within the Internet. The Internet is a packet

switching network whereby a data file routed over the Internet to some destination is broken down into a number of packets that are separately transmitted to the destination. Each packet contains, *inter alia*, some portion of the data file and the IP address of the destination.

The IP address of a destination is useful in routing packets to the correct destination  
5 but is not very people friendly. A group of four 8-bit numbers by themselves do not reveal or suggest anything about the destination and most people would find it difficult to remember the IP addresses of a destination. As a result of this shortcoming in just using IP addresses, domain names were created. Domain names consist of two or more parts, frequently words, separated by periods. Since the words, numbers, or other symbols forming a domain name  
10 often indicate or at least suggest the identity of a destination, domain names have become the standard way of entering an address and are more easily remembered than the IP addresses. After a domain name has been entered, a domain name server (DNS) resolves the domain name into a specific IP address. Thus, for example, when someone surfing the Internet enters into a browser program a particular domain name for a web site, the browser first queries the  
15 DNS to arrive at the proper IP address.

While the IP address works well to deliver packets to the correct address on the Internet, IP addresses do not convey any useful information about the geographic address of the destination. Furthermore, the domain names do not even necessarily indicate any geographic location although sometimes they may suggest, correctly or incorrectly, such a  
20 location. This absence of a link between the IP address or domain name and the geographic location holds true both nationally and internationally. For instance, a country top-level

domain format designates .us for the United States, .uk for the United Kingdom, etc. Thus, by referencing these extensions, at least the country within which the computer is located can often be determined. These extensions, however, can often be deceiving and may be inaccurate. For instance, the .md domain is assigned to the Republic of Moldova but has  
5 become quite popular with medical doctors in the United States. Consequently, while the domain name may suggest some aspect of the computer's geographic location, the domain name and the IP address often do not convey any useful geographic information.

In addition to the geographic location, the IP address and domain name also tell very little information about the person or company using the computer or computer network.  
10 Consequently, it is therefore possible for visitors to go to a web site, transfer files, or send email without revealing their true identity. This anonymity, however, runs counter to the desires of many web sites. For example, for advertising purposes, it is desirable to target each advertisement to a select market group optimized for the goods or services associated with the advertisement. An advertisement for a product or service that matches or is closely  
15 associated with the interests of a person or group will be much more effective, and thus more valuable to the advertisers, than an advertisement that is blindly sent out to every visitor to the site.

Driven often by the desire to increase advertising revenues and to increase sales, many sites are now profiling their visitors. To profile a visitor, web sites first monitor their  
20 visitors' traffic historically through the site and detect patterns of behavior for different groups of visitors. The web site may come to infer that a certain group of visitors requesting

a page or sequence of pages has a particular interest. When selecting an advertisement for the next page requested by an individual in that group, the web site can target an advertisement associated with the inferred interest of the individual or group. Thus, the visitor's traffic through the web site is mapped and analyzed based on the behavior of other  
5 visitors at the web site. Many web sites are therefore interested in learning as much as possible about their visitors in order to increase the profitability of their web site.

The desire to learn more about users of the Internet is countered by privacy concerns of the users. The use of cookies, for instance, is objectionable to many visitors. In fact, bills have been introduced into the House of Representatives and also in the Senate controlling the  
10 use of cookies or digital ID tags. By placing cookies on a user's computer, companies can track visitors across numerous web sites, thereby suggesting interests of the visitors. While many companies may find cookies and other profiling techniques beneficial, profiling techniques have not won wide-spread approval from the public at large.

A particularly telling example of the competing interests between privacy and  
15 profiling is when Double Click, Inc. of New York, New York tied the names and addresses of individuals to their respective IP addresses. The reactions to Double Click's actions included the filing of a complaint with the Federal Trade Commission (FTC) by the Electronic Privacy Information Center and outbursts from many privacy advocates that the tracking of browsing habits of visitors is inherently invasive. Thus, even though the  
20 technology may allow for precise tracking of individuals on the Internet, companies must carefully balance the desire to profile visitors with the rights of the visitors in remaining



anonymous.

A need therefore exists for systems and methods by which more detailed information may be obtained on visitors without jeopardizing or compromising the visitors' privacy rights.

5

### SUMMARY

The invention addresses the problems above by providing systems and methods for determining the geographic locations of Internet users. According to one aspect, a method of collecting geographic information involves taking one of the IP address or host name and determining the organization that owns the IP address. Preferably, the method first takes one  
10 of the IP address or host name and checks whether the host name is associated with that IP address, such as through an *nslookup* query. Next, the route to the host is acquired, preferably through a *traceroute* query, so as to determine a number of intermediate hosts. The specific route is analyzed and mapped against a database of stored geographic locations, thereby mapping out the intermediate hosts. For any intermediate host not having a location  
15 stored in the database, the method involves determining a geographic location and storing this information in the database.

According to another aspect, the invention relates to a system for determining geographic locations of Internet users. The determination system receives queries from requestors, such as web sites, for the geographic location of a certain Internet user. The  
20 determination system in turn queries a central database of stored locations and returns the geographic information if contained in the database. If the geographic information is not in

the database, then the system performs a search to collect that information. Instead of querying a central database each time geographic location of an Internet user is desired, the web site or other requestor may have geographic locations of at least some Internet users stored in a local database. The web site first checks with the local database for the  
5 geographic information and, if it not available, then sends a query to the central database.

The geographic location information of Internet users can be used for a variety of purposes. For instance, a position targeter can be associated with web sites to target the delivery of information based on the geographic location information. The web sites can selectively deliver content or advertising based on the geographic location of its visitors. The  
10 geographic location information can also be used in the routing of Internet traffic. A traffic manager associated with a number of web servers detects the geographic locations of its Internet visitors and routes the traffic to the closest server.

The databases of geographic locations can contain other information that may be useful to web sites and other requestors. The databases, for instance, can serve as a registry  
15 for allowed content that may be delivered to a particular IP address or range of IP addresses. Thus, prior to a web site delivering content to an IP address, the web site may query the database to ensure that the delivery of the content is permitted. The databases may store network speeds of Internet users whereby a web site can tailor the amount of content delivered to an Internet user based in part of the bandwidth to that user. The databases may  
20 also store an interface of an Internet user whereby a web site can tailor the content and presentation for that particular interface. Other uses of the geographic location and of the

systems and methods described herein will be apparent to those skilled in the art and are encompassed by the invention.

#### BRIEF DESCRIPTION OF DRAWINGS

5           The accompanying drawings, which are incorporated in and form a part of the specification, illustrate preferred embodiments of the present invention and, together with the description, disclose the principles of the invention. In the drawings:

          Figure 1 is a block diagram of a network having a collection system according to a preferred embodiment of the invention;

10           Figure 2 is a flow chart depicting a preferred method of operation for the collection system of Figure 1;

          Figure 3 is a flow chart depicting a preferred method of obtaining geographic information through an Internet Service Provider (ISP);

          Figure 4 is a block diagram of a network having a collection system and  
15           determination system according to a preferred embodiment of the invention;

          Figure 5 is a flow chart depicting a preferred method of operation for the collection and determination system;

          Figure 6 is a block diagram of a web server using a position targeter connected to the collection and determination system;

20           Figure 7 is a flow chart depicting a preferred method of operation for the web server and position targeter of Figure 6;

Figure 8 is a block diagram of a web server using a position targeter having access to a local geographic database as well as the collection and determination system;

Figure 9 is a flow chart depicting a preferred method of operation for the web server and position targeter of Figure 8;

5           Figure 10 is a block diagram of a network depicting the gathering of geographical location information from a user through a proxy server;

Figure 11 is a flow chart depicting a preferred method of operation for gathering geographic information through the proxy server;

10           Figure 12 is a block diagram of a traffic manager according to a preferred embodiment of the invention;

Figure 13 is a block diagram of a network including a profile server and a profile discovery server according to a preferred embodiment of the invention; and

Figures 14(A) and 14(B) are flow charts depicting preferred methods of operation for the profile server and profile discovery server of Figure 13.

15

#### DETAILED DESCRIPTION

Reference will now be made in detail to preferred embodiments of the invention, non-limiting examples of which are illustrated in the accompanying drawings.

20           I.       COLLECTING, DETERMINING AND DISTRIBUTING GEOGRAPHIC LOCATIONS

According to one aspect, the present invention relates to systems and methods of collecting, determining, and distributing data that identifies where an Internet user is likely to be geographically located. Because the method of addressing on the Internet, Internet Protocol (IP) addresses, allows for any range of addresses to be located anywhere in the world, determining the actual location of any given machine, or host, is not a simple task.

A. Collecting Geographic Location Data

A system 10 for collecting geographic information is shown in Figure 1. The system 10 uses various Internet route tools to aid in discovering the likely placement of newly discovered Internet hosts, such as new target host 34. In particular the system 10 preferably uses programs known as *host*, *nslookup*, *ping*, *traceroute*, and *whois* in determining a geographic location for the target host 34. It should be understood that the invention is not limited to these programs but may use other programs or systems that offer the same or similar functionality. Thus, the invention may use any systems or methods to determine the geographic location or provide further information that will help ascertain the geographic location of an IP address.

In particular, *nslookup*, *ping*, *traceroute*, and *whois* provide the best source of information. The operation of *ping* and *traceroute* is explained in the Internet Engineering Task Force (IETF) Request For Comments (RFC) numbered 2151 which may be found at <http://www.ietf.org/rfc/rfc2151.txt>, *nslookup* (actually DNS lookups) is explained in the IETF RFC numbered 2535 which may be found at <http://www.ietf.org/rfc/rfc2535.txt>, and

*whois* is explained in the IETF RFC numbered 954 which may be found at <http://www.ietf.org/rfc/rfc0954.txt>. A brief explanation of each of *host*, *nslookup*, *ping*, *traceroute*, and *whois* is given below. In explaining the operation of these commands, source host refers to the machine that the system 10 is run on and target host refers to the machine  
5 being searched for by the system 10, such as target host 34. A more detailed explanation of these commands is available via the RFCs specified or manual pages on a UNIX system.

*host* queries a target domain's DNS servers and collects information about the domain name. For example, with the *-l* option the command "*host -l digitalenvoy.net*" will show the system 10 all host names that have the suffix of *digitalenvoy.net*.

10 *nslookup* will convert an IP address to a host name or vice versa using the DNS lookup system.

*ping* sends a target host a request to see if the host is on-line and operational. *ping* can also be used to record the route that was taken to query the status of the target host but this is often not completely reliable.

15 *traceroute* is designed to determine the exact route that is taken to reach a target host. It is possible to use *traceroute* to determine a partial route to a non-existent or non-online target host machine. In this case the route will be traced to a certain point after which it will fail to record further progress towards the target host. The report that is provided to the system 10 by *traceroute* gives the IP address of each host encountered from the source host  
20 to the target host. *traceroute* can also provide host names for each host encountered using DNS if it is configured in this fashion.

*whois* queries servers on the Internet and can obtain registration information for a domain name or block of IP addresses.

A preferred method 100 of operation for the system 10 will now be described with reference to Figures 1 and 2. At 102, the system 10 receives a new address for which a geographic location is desired. The system 10 accepts new target hosts that are currently not  
5 contained in its database 20 or that need to be re-verified. The system 10 requires only one of the IP address or the host name, although both can be provided. At 103, the system 10 preferably, although not necessarily, verifies the IP address and host name. The system 10 uses *nslookup* to obtain the host name or IP address to verify that both pieces of information  
10 are correct. Next, at 104, the system 10 determines if the target host 34 is on-line and operational and preferably accomplishes this function through a *ping*. If the host 34 is not on-line, the system 10 can re-queue the IP address for later analysis, depending upon the preferences in the configuration of the system 10.

At 106, the system 10 determines ownership of the domain name. Preferably, the  
15 system 10 uses a *whois* to determine the organization that actually owns the IP address. The address of this organization is not necessarily the location of the IP address but this information may be useful for smaller organizations whose IP blocks are often geographically in one location. At 107, the system 10 then determines the route taken to reach the target host 34. Preferably, the system 10 uses a *traceroute* on the target host 34. At  
20 108, the system 10 takes the route to the target host 34 and analyzes and maps it geographically against a database 20 of stored locations. If any hosts leading to the target

host, such as intermediate host 32, are not contained in the database 20, the system 10 makes a determination as to the location of those hosts.

At 109, a determination is then made as to the location of the target host and a confidence level, from 0 to 100, is assigned to the determination based on the confidence level of hosts leading to and new hosts found and the target host 34. All new hosts and their respective geographic locations are then added to the database 20 at 110.

If the host name is of the country top-level domain format (.us, .uk, etc.) then the system 10 first maps against the country and possibly the state, or province, and city of origin. The system 10, however, must still map the Internet route for the IP address in case the address does not originate from where the domain shows that it appears to originate. As discussed in the example above, the .md domain is assigned to the Republic of Moldova but is quite popular with medical doctors in the United States. Thus, the system 10 cannot rely completely upon the country top-level domain formats in determining the geographic location.

The method 100 allows the system 10 to determine the country, state, and city that the target host 34 originates from and allow for an assignment of a confidence level against entries in the database. The confidence level is assigned in the following manner. In cases where a dialer has been used to determine the IP address space assigned by an Internet Service Provider to a dial-up modem pool, which will be described in more detail below, the confidence entered is 100. Other confidences are based upon the neighboring entries. If two same location entries surround an unknown entry, the unknown entry is given a confidence



of the average of the known same location entries. For instance, a location determined solely by *whois* might receive a 35 confidence level.

As an example, a sample search against the host "*digitalenvoy.net*" will now be described. First, the system 10 receives the target host "*digitalenvoy.net*" at 102 and does a

5 DNS lookup on the name at 103. The command *nslookup* returns the following to the system 10:

```
> nslookup digitalenvoy.net
Name:    digitalenvoy.net
10 Address: 209.153.199.15
```

The system 10 at 104 then does a *ping* on the machine, which tells the system 10 if the target host 34 is on-line and operational. The "*-c 1*" option tells *ping* to only send one packet. This option speeds up confirmation considerably. The *ping* returns the following to the system

15 10:

```
> ping -c 1 digitalenvoy.net
PING digitalenvoy.net (209.153.199.15): 56 data bytes
20 64 bytes from 209.153.199.15: icmp_seq=0 ttl=241 time=120.4 ms

--- digitalenvoy.net ping statistics ---
1 packets transmitted, 1 packets received, 0% packet loss
round-trip min/avg/max = 120.4/120.4/120.4 ms
```

25 The system 10 next executes a *whois* at 106 on "*digitalenvoy.net*". In this example, the *whois* informs the system 10 that the registrant is in Georgia.

```
> whois digitalenvoy.net
Registrant:
30 Some One (DIGITALENVOY-DOM)
    1234 Address Street
    ATLANTA, GA 33333
    US
```

Domain Name: DIGITALENVOY.NET

Administrative Contact:

5 One, Some (SO0000) some@one.net  
+1 404 555 5555

Technical Contact, Zone Contact:

myDNS Support (MS311-ORG) support@MYDNS.COM  
+1 (206) 374.2143

Billing Contact:

10 One, Some (SO0000) some@one.net  
+1 404 555 5555

Record last updated on 14-Apr-99.

Record created on 14-Apr-99.

15 Database last updated on 22-Apr-99 11:06:22 EDT.

Domain servers in listed order:

|    |                  |               |
|----|------------------|---------------|
| 20 | NS1.MYDOMAIN.COM | 209.153.199.2 |
|    | NS2.MYDOMAIN.COM | 209.153.199.3 |
|    | NS3.MYDOMAIN.COM | 209.153.199.4 |
|    | NS4.MYDOMAIN.COM | 209.153.199.5 |

The system 10 at 107 executes a *traceroute* on the target host 34. The *traceroute* on

25 "*digitalenvoy.net*" returns the following to the system 10:

```

> traceroute digitalenvoy.net
traceroute to digitalenvoy.net (209.153.199.15), 30 hops max, 40
byte packets
30  1 130.207.47.1 (130.207.47.1)  6.269 ms  2.287 ms  4.027 ms
   2 gateway1-rtr.gatech.edu (130.207.244.1)  1.703 ms  1.672 ms
   1.928 ms
   3 f1-0.atlanta2-cr99.bbnplanet.net (192.221.26.2)  3.296 ms
   3.051 ms  2.910 ms
35  4 f1-0.atlanta2-br2.bbnplanet.net (4.0.2.90)  3.000 ms  3.617 ms
   3.632 ms
   5 s4-0-0.atlanta1-br2.bbnplanet.net (4.0.1.149)  4.076 ms s8-1-
   0.atlanta1-br2.bbnplanet.net (4.0.2.157)  4.761 ms  4.740 ms
40  6 h5-1-0.paloalto-br2.bbnplanet.net (4.0.3.142)  72.385 ms
   71.635 ms  69.482 ms
   7 p2-0.paloalto-nbr2.bbnplanet.net (4.0.2.197)  82.580 ms
   83.476 ms  82.987 ms
   8 p4-0.sanjose1-nbr1.bbnplanet.net (4.0.1.2)  79.299 ms  78.139
   ms  80.416 ms
45  9 p1-0-0.sanjose1-br2.bbnplanet.net (4.0.1.82)  78.918 ms
   78.406 ms  79.217 ms
  10 NSanjose-core0.nap.net (207.112.242.253)  80.031 ms  78.506 ms
  122.622 ms

```

- 11 NSeattle1-core0.nap.net (207.112.247.138) 115.104 ms 112.868 ms 114.678 ms
- 12 sea-atm0.starcom-accesspoint.net (207.112.243.254) 112.639 ms 327.223 ms 173.847 ms
- 5 13 van-atm10.10.starcom.net (209.153.195.49) 118.899 ms 116.603 ms 114.036 ms
- 14 hume.worldway.net (209.153.199.15) 118.098 ms \* 114.571 ms

After referring to the geographic locations stored in the database 20, the system 10

10 analyzes these hops in the following way:

|  |   |
|--|---|
| 130.207.47.1 (130.207.47.1)                        | Host machine located in Atlanta, GA                 |
| gateway1-rtr.gatech.edu (130.207.244.1)            | Atlanta, GA - confidence 100                        |
| f1-0.atlanta2-cr99.bbnplanet.net (192.221.26.2)    | Atlanta, GA - confidence 100                        |
| f1-0.atlanta2-br2.bbnplanet.net (4.0.2.90)         | Atlanta, GA - confidence 95                         |
| s4-0-0.atlantatl-br2.bbnplanet.net (4.0.1.149)     | Atlanta, GA - confidence 80                         |
| h5-1-0.paloalto-br2.bbnplanet.net (4.0.3.142)      | Palo Alto, CA - confidence 85                       |
| p2-0.paloalto-nbr2.bbnplanet.net (4.0.2.197)       | Palo Alto, CA - confidence 90                       |
| p4-0.sanjose1-nbr1.bbnplanet.net (4.0.1.2)         | San Jose, CA - confidence 85                        |
| p1-0-0.sanjose1-br2.bbnplanet.net (4.0.1.82)       | San Jose, CA - confidence 100                       |
| NSanjose-core0.nap.net (207.112.242.253)           | San Jose, CA - confidence 90                        |
| NSeattle1-core0.nap.net (207.112.247.138)          | Seattle, WA - confidence 95                         |
| sea-atm0.starcom-accesspoint.net (207.112.243.254) | Seattle, WS - confidence 95                         |
| van-atm10.10.starcom.net (209.153.195.49)          | Vancouver, British Columbia Canada - confidence 100 |
| hume.worldway.net (209.153.199.15)                 | Vancouver, British Columbia Canada                  |

The system 10 assigns a confidence level of 99 indicating that the entry is contained in the database 20 and has been checked by a person for confirmation. While confirmations may be performed by persons, such as an analyst, according to other aspects of the invention

15 the confirmation may be performed by an Artificial Intelligence system or any other suitable additional system, module, device, program, entities, etc. The system 10 reserves a confidence level of 100 for geographic information that has been confirmed by an Internet

Service Providers (ISP). The ISP would provide the system 10 with the actual mapping of IP addresses against geography. Also, data gathered with the system 10 through dialing ISPs is given a 100 confidence level because of a definite connection between the geography and the IP address. Many of these hosts, such as intermediate host 32, will be repeatedly traversed  
5 when the system 10 searches for new target hosts, such as target host 34, and the confidence level of their geographic location should increase up to a maximum 99 unless confirmed by an ISP or verified by a system analyst. The confidence level can increase in a number of ways, such as by a set amount with each successive confirmation of the host's 32 geographic location.

10 The system 10 takes advantage in common naming conventions in leading to reasonable guesses as to the geographic location of the hosts. For example, any host that contains "sanjose" in the first part of its host name is probably located in San Jose, California or connected to a system that is in San Jose, California. These comparison rule sets are implemented in the system 10 as entries in the database 20. The database 20 may have look-  
15 up tables listing geographic locations, such as city, county, regional, state, etc, with corresponding variations of the names. Thus, the database 20 could have multiple listings for the same city, such as SanFrancisco, SanFran, and Sfrancisco all for San Francisco, California.

Often a block of IP addresses are assigned and sub-assigned to organizations. For  
20 example, the IP block that contains the target address 209.153.199.15 can be queried:

```
> whois 209.153.199.15@whois.arin.net  
[whois.arin.net]  
Starcom International Optics Corp. (NETBLK-STARCOM97) STARCOM97
```

209.153.192.0 -  
 209.153.255.255  
 WORLDWAY HOLDINGS INC. (NETBLK-WWAY-NET-01) WWAY-NET-01  
 209.153.199.0 -  
 5 209.153.199.255

From the results of this query, the system 10 determines that the large block from 209.153.192.0 to 209.153.255.255 is assigned to Starcom International Optics Corp. Within this block, Starcom has assigned Worldway Holdings Inc. the 209.153.199.0 to  
 10 209.153.199.255 block. By further querying this block (NETBLK-WWAY-NET-01) the collection system 10 gains insight into where the organization exists. In this case the organization is in Vancouver, British Columbia, as shown below.

```

15 > whois NETBLK-WWAY-NET-01@whois.arin.net
[whois.arin.net]
WORLDWAY HOLDINGS INC. (NETBLK-WWAY-NET-01)
  1336 West 15th Street
  North Vancouver, BC V7L 2S8
  CA
20
Netname: WWAY-NET-01
Netblock: 209.153.199.0 - 209.153.199.255

Coordinator:
25   WORLDWAY DNS (WD171-ORG-ARIN)  dns@WORLDWAY.COM
    +1 (604) 608.2997

Domain System inverse mapping provided by:
30 NS1.MYDNS.COM           209.153.199.2
   NS2.MYDNS.COM           209.153.199.3

```

With the combination of the trace and the IP block address information, the collection system 10 can be fairly certain that the host “*digitalenvoy.net*” is located in Vancouver,  
 35 British Columbia. Because the collection system 10 “discovered” this host using automatic methods with no human intervention, the system 10 preferably assigns a confidence level

slightly lower than the confidence level of the host that led to it. Also, the system 10 will not assume the geographic location will be the same for the organization and the sub-block of IP addresses assigned since the actual IP address may be in another physical location. The geographic locations may easily be different since IP blocks are assigned to a requesting  
5 organization and no indication is required for where the IP block will be used.

#### B. Obtaining Geographic Location Data from ISPs

A method 111 for obtaining geographic locations from an ISP will now be described with reference to Figure 3. At 112, the collection system 10 obtains access numbers for the  
10 ISP. The access numbers in the preferred embodiment are dial-up numbers and may be obtained in any suitable manner, such as by establishing an account with the ISP. Next, at 113, the collection system 10 connects with the ISP by using one of the access numbers. When the collection system 10 establishes communications with the ISP, the ISP assigns the collection system 10 an IP address, which is detected by the collection system 10 at 114.

15 The collection system 10 at 115 then determines the route to a sample target host and preferably determines this route through a *traceroute*. The exact target host that forms the basis of the *traceroute* as well as the final destination of the route is not important so any suitable host may be used. At 116, the collection system 10 analyzes the route obtained through *traceroute* to determine the location of the host associated with the ISP. Thus, the  
20 collection system 10 looks in a backward direction to determine the geographic location of the next hop in the *traceroute*. At 117, the collection system 10 stores the results of the

analysis in the database 20.

With the method 111, the collection system 10 can therefore obtain the geographic locations of IP addresses with the assistance of the ISPs. Because the collection system 10 dials-up and connects with the ISP, the collection system 10 preferably performs the method 111 in a such a manner so as to alleviate the load placed on the ISP. For instance, the collection system 10 may perform the method 111 during off-peak times for the ISP, such as during the night. Also, the collection system 10 may control the frequency at which it connects with a particular ISP, such as establishing connections with the ISP at 10 minute intervals.

10

#### C. Determining Geographic Location Data

With reference to Figure 4, according to another aspect, the invention relates to a geographic determination system 30 that uses the database 20 created by the collection system 10. The determination system 10 receives requests for a geographic location and based on either the IP address or host name of the host being searched for, such as target host 34. A geographic information requestor 40 provides the request to, and the response from, the determination system 30 in an interactive network session that may occur through the Internet 7 or through some other network. The collection system 10, database 20, and determination system 30 can collectively be considered a collection and determination system 50.

20

A preferred method 120 of operation for the determination system 30 will now be

described with reference to Figure 5. At 122, the system 30 receives a request for the geographic location of an entity and, as discussed above, receives one or both of the IP address and domain name. At 123, the determination system 30 searches the database 20 for the geographic location for the data provided, checking to see if the information has already  
5 been obtained. When searching for an IP address at 123, the system 30 also tries to find either the same exact IP address listed in the database 20 or a range or block of IP addresses listed in the database 20 that contains the IP address in question. If the IP address being searched for is within a block of addresses, the determination system 30 considers it a match, the information is retrieved at 125, and the geographic information is delivered to the  
10 requestor 40 at 126. If the information is not available in database 20, as determined at 124, then at 127 the system 30 informs the requestor 40 that the information is not known. At 128, the system 30 then determines the geographic location of the unknown IP address and stores the result in the database 20. As an alternative at 125 to stating that the geographic location is unknown, the system 30 could determine the geographic information and provide  
15 the information to the requestor 40.

The determination system 30 looks for both the IP address in the database 20 and also for the domain name. Since a single IP address may have multiple domain names, the determination system 30 looks for close matches to the domain name in question. For instance, when searching for a host name, the system 30 performs pattern matching against  
20 the entries in the database 20. When a match is found that suggests the same IP address, the determination system 30 returns the geographic data for that entry to the requestor 40.



An ambiguity may arise when the requestor 40 provides both an IP address and a domain name and these two pieces of data lead to different hosts and different geographic locations. If both data pieces do not exactly match geographically, then the system 30 preferably responds with the information that represents the best confidence. As another example, the system 30 may respond in a manner defined by the requestor 40. As some options, the determination system 30 can report only when the data coincide and agree with each other, may provide no information in the event of conflicting results, may provide the geographic information based only on the IP address, may provide the geographic information based only on the host name, or may instead provide a best guess based on the extent to which the address and host name match.

A sample format of a request sent by the requestor 40 to the determination system 30 is provided below, wherein the search is against the host "*digitalenvoy.net*" and the items in **bold** are responses from the geographic determination system 30:

```
15 Connecting to server.digitalenvoy.net...  
;digitalenvoy.net;  
vancouver;british columbia;can;99;
```

The format of the request and the format of the output from the determination system 30 can of course be altered according to the application and are not in any way limited to the example provided above.

#### D. Distributing Geographic Location Data

A system for distributing the geographic location information will now be described

with reference to Figures 6 and 7. According to a first aspect shown in Figure 6, the geographic information on IP addresses and domain names is collected and determined by the system 50. A web site 60 may desire the geographic locations of its visitors and would desire this information from the collection and determination system 50. The web site 60  
5 includes a web server 62 for receiving requests from users 5 for certain pages and a position targeter 64 for at least obtaining the geographic information of the users 5.

A preferred method 130 of operation of the network shown in Figure 6 will now be described with reference to Figure 7. At 132, the web server 62 receives a request from the user 5 for a web page. At 133, the web server 62 queries the position targeter 64 that, in turn,  
10 at 134 queries the collection and determination system 50 for the geographic location of the user. Preferably, the position targeter 64 sends the query through the Internet 7 to the collection and determination system 50. The position targeter 64, however, may send the query through other routes, such as through a direct connection to the collection and determination system 50 or through another network. As discussed above, the collection and  
15 determination system 50 accepts a target host's IP address, host name, or both and returns the geographic location of the host in a format specified by the web site 60. At 135, the position targeter obtains the geographic location from the collection and determination system 50, at 136 the information that will be delivered to the user 5 is selected, and is then delivered to the user 5 at 137. This information is preferably selected by the position targeter based on  
20 the geographic location of the user 5. Alternatively, the position targeter 64 may deliver the geographic information to the web server 62 which then selects the appropriate information

to be delivered to the user 5. As discussed in more detail below, the geographic location may have a bearing on what content is delivered to the user, what advertising, the type of content, if any, delivered to the user 5, and/or the extent of content.

As another option shown in Figure 8, the web site 60 may be associated with a local  
5 database 66 storing geographic information on users 5. With reference to Figure 9, a preferred method 140 of operation begins at 142 with the web server 62 receiving a request from the user 5. At 143, the web server 62 queries a position targeter 64' for the geographic location information. Unlike the operation 130 of the position targeter 64 in Figures 6 and 7, the position targeter' next first checks the local database 66 for the desired geographic  
10 information. If the location information is not in the database 66, then at 145 the position targeter 64' queries the database 20 associated with the collection and determination system 50.

After the position targeter 64' obtains the geographic information at 146, either locally from database 66 or centrally through database 20, the desired information is selected  
15 based on the geographic location of the user 5. Again, as discussed above, this selection process may be performed by the position targeter 64' or by the web server 62. In either event, the selected information is delivered to the user 5 at 148.

For both the position targeter 64 and position targeter 64', the position targeter may be configured to output HTML code based on the result of the geographic location query.  
20 An HTML code based result is particularly useful when the web site 60 delivers dynamic web pages based on the user's 5 location. It should be understood, however, that the output

of the position targeter 64 and position targeter 64' is not limited to HTML code but encompasses any type of content or output, such as JPEGs, GIFs, etc.

A sample search against the host "*digitalenvoy.net*" is shown here (items in **bold** are responses from the position targeter 64 or 64':

5

```
> distributionprogram digitalenvoy.net  
vancouver;british columbia;can;99;
```

The format of the output, of course, may differ if different options are enabled or disabled.

10

End users 5 may elect a different geographic location as compared to where they have been identified from by the system 50 when it possibly chooses an incorrect geographic location. If this information is passed backed to the position targeter 64 or 64', the position targeter 64 or 64' will pass this information to the determination system 30 which will store this in the database 20 for later analysis. Because this information cannot be trusted

15 completely, the collection and determination system 50 must analyze and verify the information and possibly elect human intervention.

#### E. Determining Geographic Locations Through A Proxy Server

One difficulty in providing geographic information on a target host is when the target

20 host is associated with a caching proxy server. A caching proxy will make requests on behalf of other network clients and save the results for future requests. This process reduces the amount of outgoing bandwidth from a network that is required and thus is a popular choice for many Internet access providers. For instance, as shown in Figure 10, a user 5 may be associated with a proxy server 36.

In some cases, this caching is undesirable since the data inside them becomes stale. The web has corrected this problem by having a feature by which pages can be marked uncacheable. Unfortunately, the requests for these uncacheable pages still look as if they are coming from the proxy server 36 instead of the end-user computers 5. The geographic information of the user 5, however, may often be required.

A method 150 of determining the geographic information of the user 5 associated with the proxy server 36 will now be described with reference to Figure 11. In the preferred embodiment, the user 5 has direct routable access to the network; e.g. a system using Network Address Translation will not work since the address is not a part of the global Internet. Also, the proxy server 36 should allow access through arbitrary ports whereby a corporate firewall which blocks direct access on all ports will not work. Finally, the user 5 must have a browser that supports Java Applets or equivalent such functionality.

With reference to Figure 11, at 152, a user 5 initiates a request to a web server 60, such as the web server 60 shown in Figure 6 or Figure 8. At 153, the HTTP request is processed by the proxy server 36 and no hit is found in the proxy's cache because the pages for this system are marked uncacheable. On behalf of the user 5, the proxy server 38 connects to the web server 60 and requests the URL at 153. At 154, the web server 60 either through the local database 60 or through the database 20 with the collection and determination system 50, receives the request, determines it is coming from a proxy server 36, and then at 155 selects the web page that has been tagged to allow for the determination of the user's 5 IP address. The web page is preferably tagged with a Java applet that can be used to determine

the IP address of the end-user 5. The web server 60 embeds a unique applet parameter tag for that request and sends the document back to the proxy server 36. The proxy server 36 then forwards the document to the user 5 at 156.

At 157, the user's 5 browser then executes the Java Applet, passing along the unique parameter tag. Since by default applets have rights to access the host from which they came, the applet on the user's 5 browser opens a direct connection to the client web server 60, such as on, but not limited to, port 5000. The web server 60, such as through a separate server program, is listening for and accepts the connection on port 5000. At 158, the Java applet then sends back the unique parameter tag to the web server 60. Since the connection is direct, the web server 60 at 159 can determine the correct IP address for the user 5, so the web server 60 now can associate the session tag with that IP address on all future requests coming from the proxy server 38.

As an alternative, at 155, the web server 155 may still deliver a web page that has a Java applet. As with the embodiment discussed above, the web page having the Java applet is delivered to the proxy server at 156 and the user 5 connects with the web server 60 at 157. The Java applet according to this embodiment of the invention differs from the Java applet discussed above in that at 158 the Java applet reloads the user's browser with what it was told to load by the web server 60. The Java applet according to this aspect of the invention is not associated with a unique parameter tag that alleviates the need to handle and to sort the plurality of unique parameter tags. Instead, with this aspect of the invention, the web server 60 at 159 determines the IP address and geographic location of the user 5 when the Java

applet connects to the web server 60.

II. TAILORING AN INTERNET SITE BASED ON GEOGRAPHIC  
LOCATION OF ITS VISITORS

5           The web site 60 can tailor the Internet site based upon the geographic location or  
Internet connection speed of an Internet user 5. When the user 5 visits the Internet site 60,  
the Internet site 60 queries a database, such as local database 60 or central database 20, over  
the Internet which then returns the geographic location and/or Internet connection speed of  
the user based upon the user's IP address and other relevant information derived from the  
10 user's "hit" on the Internet site 60. This information may be derived from the route to the  
user's 5 machine, the user's 5 host name, the hosts along the route to the user's machine 5,  
via SNMP, and/or via NTP but not limited to these techniques. Based on this information the  
Internet site 60 may tailor the content and/or advertising presented to the user. This tailoring  
may also include, but not be limited to, changing the language of the Internet site to a user's  
15 native tongue based on the user's location, varying the products or advertising shown on an  
Internet site based upon the geographic information and other information received from the  
database, or preventing access based on the source of the request (i.e. "adult" content sites  
rejecting requests from schools, etc.). This tailoring can be done by having several  
alternative screens or sites for a user and having the web server 62 or position targeter 64 or  
20 64' dynamically select the proper one based upon the user's geographic information. The  
geographic information can also be analyzed to effectively market the site to potential

Internet site advertisers and external content providers or to provide media-rich content to users that have sufficient bandwidth.

The methods of tailoring involve tracing the path back to the Internet user's machine 5, determining the location of all hosts in the path, making a determination of the likelihood of the location of the Internet user's machine, determining other information about the hosts, 5 which may or may not be linked to its geographic location, in the path to and including the Internet user's machine by directly querying them for such information (by using, but not limited by, SNMP or NTP for example), or alternatively, there is a complete database that may be updated that stores information about the IP addresses and host names which can be 10 queried by a distant source which would then be sent information about the user.

The web site 60 dynamically changes Internet content and/or advertising based on the geographic location of the Internet user 5 as determined from the above methods or processes. The web site 60 presents one of several pre-designed alternative screens, presentations, or mirror sites depending on the information sent by the database as a result of 15 the user 5 accessing the web site 60.

As discussed above, the selection of the appropriate information to deliver to the user 5 base on the geographic location can be performed either by the web server 62 or the position targeter 64 or 64'. In either case, the web site can dynamically adapt and tailor Internet content to suit the needs of Internet users 5 based on their geographic location and/or 20 connection speed. As another option, the web site 60 can dynamically adapt and tailor Internet advertising for targeting specific Internet users based on their geographic location



and/or connection speed. Furthermore, the web site 60 can dynamically adapt and tailor Internet content and/or advertising to the native language of Internet users 5 which may be determined by their geographic location. Also, the web site 60 can control access, by selectively allowing or disallowing access, to the Internet site 60 or a particular web page on the site 60 based on the geographic location, IP Address, host name and/or connection speed of the Internet user. As another example, the web site can analyze visits by Internet users 5 in order to compile a geographic and/or connection speed breakdown of Internet users 5 to aid in the marketing of Internet sites.

10           A.     CREDIT CARD FRAUD

In addition to using geographic location information to target information to the user, the web site 60 or the collection and determination system 50 can provide a mechanism for web sites owners to detect possible cases on online credit card fraud. When a user 5 enters information to complete an on-line order, he/she must give a shipping and billing address. This information cannot currently be validated against the physical location of the user 5. Through the invention, the web site 60 determines the geographic location of the user 5. If the user 5 enters a location that he is determined not to be in, there could be a possible cause of fraud. This situation would require follow up by the web site owner to determine if the order request was legitimate or not.

20

          B.     SITE MANAGEMENT

In addition to using geographic information to detect credit card fraud, the geographic information can also be used in managing traffic on the Internet 7. For example, with reference to Figure 12, a traffic manager 70 has the benefit of obtaining the geographic information of its users or visitors 5. The traffic manager 70 may employ the local database 60 or, although not shown, may be connected to the collection and determination system 50. After the traffic manager 70 detects the geographic location of the users 5, the traffic manager 70 directs a user's 5 request to the most desirable web server, such as web server A 74 or web server B 72. For instance, if the user 5 is in Atlanta, the traffic manager 70 may direct the user's request to web server A 74 which is based in Atlanta. On the other hand, if the user 5 is in San Francisco, then the traffic manager 70 would direct the user 5 to web server B, which is located in San Francisco. In this manner, the traffic manager 70 can reduce traffic between intermediate hosts and direct the traffic to the closest web server.

### III. PROFILE SERVER AND PROFILE DISCOVERY SERVER

As discussed above, the collection and determination system 50 may store geographic information on users 5 and provide this information to web sites 60 or other requesters 40. According to another aspect of the invention, based on the requests from the web sites 60 and other requesters 40, information other than the geographic location of the users 5 is tracked. With reference to Figure 13, a profile server 80 is connected to the web site 60 through the Internet and also to a profile discovery server 90, which may also be through the Internet, through another network connection, or a direct connection. The profile server 80 comprises

a request handler 82, a database server engine 83, and a database 84. As will be more apparent from the description below, the database 84 includes a geography database 84A, an authorization database 84B, a network speed database 84C, a profile database 84D, and an interface database 84E. The profile discovery server 90 includes a discoverer engine 92, a  
5 profiler 93, and a database 94. The database 94 includes a common geographic names database 94A, a global geographic structure database 94B, and a MAC address ownership database 94C.

#### A. PROFILER

10 In general, the profile server 80 and profile discovery server 90 gather information about specific IP addresses based upon the Internet users' interactions with the various web sites 60 and other requestors 40. This information includes, but is not limited to, the types of web sites 60 visited, pages hit such as sports sites, auction sites, news sites, e-commerce sites, geographic information, bandwidth information, and time spent at the web site 60. All of this  
15 information is fed from the web site 60 in the network back to the database 84. This information is stored in the high performance database 84 by IP address and creates an elaborate profile of the IP address based on sites 60 visited and actions taken within each site 60. This profile is stored as a series of preferences for or against predetermined categories. No interaction is necessarily required between the web site 60 and the user's  
20 browser to maintain the profile. Significantly, this method of profiling does not require the use of any cookies that have been found to be highly objectionable by the users. While cookies are not

preferred, due to difficulties induced by network topology, cookies may be used to track certain users 5 after carefully considering the privacy issues of the users 5.

As users 5 access web sites 60 in the network, profiled information about the IP address of the user 60 is sent from the database 84 to the position targeter 64 or 64' at the web site 60. As explained above, the position targeter 64 or 64' or the web server 62 allows pre-set configurations or pages on the web site 60 to then be dynamically shown to the user 5 based on the detailed profile of that user 5. In addition preferences of users 5 similar to those of a current user 5 can be used to predict the content that the current user 5 may prefer to view. The information profiled could include, but is not limited to, the following: geographic location, connection speed to the Internet, tendency to like/dislike any of news, weather, sports, entertainment, sporting goods, clothing goods, etc.

As an example, two users are named Alice and Bob. Alice visits a web site, www.somerandomsite.com. This site, asks the profile server 80, such as server.digitalenvoy.net, where Alice is from and what she likes/dislikes. The database 84 has no record of Alice but does know from geography database 84A that she is from Atlanta, GA and notifies the web site to that effect. Using Alice's geographic information, the web site sends Alice a web page that is tailored for her geographic location, for instance it contains the Atlanta weather forecast and the new headlines for Atlanta. Alice continues to visit the web site and buys an umbrella from the site and then terminates her visit. The web site lets the profile server 80 and database 84 know that Alice bought an umbrella from the site. Bob then visits the site www.somerandomsite.com. The site again asks the profile server 80, such

as a server.digitalenvoy.net, about Bob. The server 80 looks in the database 84 for information on Bob and finds none. Again though, the server 80 looks in the geography database 84A and determines that he is from Atlanta, GA. Also, based on the data gathered in part from Alice and stored in profile database 84D, the profile server 80 infers that people  
5 from Atlanta, GA may like to buy umbrellas. The site uses Bob's geographic information and the fact that Atlantans have a propensity to buy umbrellas to send Bob a web page with Atlanta information, such as the weather and news, and an offer to buy an umbrella. Bob buys the umbrella and the site sends this information to the server 80, thereby showing a greater propensity for Atlantan's to buy umbrellas.

10 In addition, if the profile stored in the profile database 84D in profile server 80 shows that an IP Address has previously hit several e-commerce sites and sports sites in the network and that the address is located in California, the web site can be dynamically tailored to show sports items for sale that are more often purchased by Californians, such as surf boards. This method allows for more customized experiences for users at e-commerce and information  
15 sites.

This information can also be compiled for web sites in the network or outside the network. Web sites outside of the network can develop profiles of the users typically hitting their web site. Log files of web sites can be examined and IP Addresses can be compared against the profiled IP Address information stored on the central server. This will allow web  
20 sites to analyze their traffic and determine the general profile of users hitting the site.

In order to remove "stale" information, the database server engine 83 occasionally

purges the database 84 in the profile server 80. For example, a user 5 that is interested in researching information about a trip will probably not want to continue seeing promotions for that trip after the trip has been completed. By purging the database 84, old preferences are removed and are updated with current interests and desires.

5

#### B. CONTENT REGISTRY

In addition to the examples provided above, the profile server 80 can provide a mechanism for end users 5 to register their need for certain types of information content to be allowed or disallowed from being served to their systems. Registration is based on IP  
10 address and registration rights are limited to authorized and registered owners of the IP addresses. These owners access the profile server 80 through the Internet and identify classes of Internet content that they would want to allow or disallow from being served to their IP addresses ranges. The classes of Internet content that a particular IP address or block of addresses are allowed or disallowed from receiving is stored by the profile server 80 in the  
15 authorization database 84B. Internet content providers, such as web sites 60, query the profile server 80, which in turn queries the authorization database 84B, and identify users 5 that do or do not want to receive their content based on this IP address registry.

For example, a school registers their IP ranges and registers with the profile server 80 to disallow adult content from being sent to their systems. When an access is made from  
20 machines within the school's IP range to an adult site, the adult site checks with the profile server 80 and discovers that content provided by the adult site is disallowed from being sent

to those IP addresses. Instead of the adult content, the adult site sends a notice to the user that the content within the site cannot be served to his/her machine. This series of events allows end IP address owners to control the content that will be distributed and served to machines within their control.

5

### C. BANDWIDTH REGISTRY

The profile server 80 preferably is also relied upon in determining the amount of content to be sent to the user 5. Web sites 60 dynamically determine the available bandwidth to a specific user and provide this information to the profile server 80, which stores this  
10 information in the network speed database 84C. In addition, the web site 60 examines the rate and speed by which a specific user 5 is able to download packets from the web site 60, the web site 60 determines the available bandwidth from the web site 60 to the end user 5. If there is congestion at the web site 60, on the path to the end user 5, or at the last link to the user's 5 terminal, the web site 60 limits the available bandwidth for that user 5. Based on  
15 this information, the web site 60 can dynamically reduce the amount of information being sent to the user 60 and consequently increase download times perceived by the user 5. The bandwidth information is preferably sent to the profile server 80 and stored in the network speed database 84C so that other sites 60 in the network have the benefit of this bandwidth information without having to necessarily measure the bandwidth themselves.

20 In order to remove "stale" bandwidth information, the database server engine 83 occasionally purges the information in the network speed database 84C. For example,

congestion between a web site 60 and a user 5 will usually not persist.

#### D. INTERFACE REGISTRY

Web sites 60 also preferably are able to dynamically determine the interface that a  
5 user 5 has to view the web site 60. This user interface information may be placed in the  
database 84E through a registration process, may be known from the ISP, or may be detected  
or discovered in other ways. Personal Digital Assistant (PDA) users are shown a web site 60  
with limited or no graphics in order to accommodate the PDAs limited storage capabilities.  
Web sites 60 query the profile server 80 when accessed by a user 5. The profile server 80, in  
10 turn, queries the interface database 84E and, if available, retrieves the type of interface  
associated with a particular IP address. The profile server 80 stores in the database 84E all  
users and informs the web site 60 of the display interface that the user 5 has. Based on this  
information, the web site 60 tailors the information that is being sent to the user 5.

#### 15 E. METHODS OF OPERATION

A preferred method 160 of operation for the profile server 80 and profile discovery  
server 90 will now be described with reference to Figures 14(A) and 14(B). At 162, the  
profile server 80 is given an IP address or host name to query. At 163, the profile server 80  
determines whether the requestor is authorized to receive the information and, if not, tells the  
20 requestor at 166 that the information is unknown. The inquiry as to whether the requestor is  
authorized at 163 is preferably performed so that only those entities that have paid for access



to the profile server 80 and profile discovery server 90 obtain the data. If the requestor is authorized, then the profile server at 164 determines whether the profile of the address is known. If the profile for that address is known, the profile server 80 sends the requested information to the requestor at 165, otherwise the profile server 80 at 166 informs the  
5 requestor that the information is unknown.

For information that is unknown to the profile server 80, the profile server 80 passes the information to the profile discovery server 90 at 167. At 168, the profile discovery server determines the route to the address, at 169 obtains known information about all hosts in route from the profile server 80, and then decides at 170 whether any unknown hosts are left in the  
10 route. If no unknown hosts are left in the route, then at 171 the profile discovery server 90 returns an error condition and notifies the operator.

For each host name left in the route, the profile discovery server 90 next at 172 determines whether a host name exists for the unknown host. If so, then at 173 the profile discovery server attempts to determine the location based on common host name naming  
15 conventions and/or global country based naming conventions. At 174, the profile discovery server 90 checks whether the host responds to NTP queries and, if so, at 175 attempts to determine the time zone based on the NTP responses. At 176, the profile discovery server 90 checks whether the host responds to SNMP queries and, if so, at 177 attempts to determine the location, machine type, and connection speed based on public SNMP responses. Next, at  
20 178, the profile discovery server 90 checks whether the host has a MAC address and, if so, attempts to determine machine type and connection speed based on known MAC address

delegations.

At 180, the profile discovery server 90 determines whether any additional unknown hosts exist. If so, the profile discovery server 90 returns to 172 and checks whether a host name is available. When no more unknown hosts exist, the profile discovery server 90 at 181  
5 interpolates information to determine any remaining information, at 182 flags the interpolated data for future review, and at 183 saves all discovered and interpolated data at the profile server 80.

The foregoing description of the preferred embodiments of the invention has been presented only for the purpose of illustration and description and is not intended to be  
10 exhaustive or to limit the invention to the precise forms disclosed. Many modifications and variations are possible in light of the above teaching.

The embodiments were chosen and described in order to explain the principles of the invention and their practical application so as to enable others skilled in the art to utilize the invention and various embodiments and with various modifications as are suited to the  
15 particular use contemplated.

CLAIMS

What is claimed:

1. A method of determining the geographic locations of Internet users,  
5 comprising:
  - receiving one of an IP address or domain name associated with an Internet user;
  - determining a geographic address of an entity that owns the IP address;
  - obtaining a route through the Internet to a target host for the IP address;
  - deriving a geographic location of any intermediate hosts contained within the route  
10 through the Internet to the target host;
  - analyzing the route and the geographic locations of any intermediate hosts;
  - determining the geographic location of the Internet user; and
  - storing the geographic location of the Internet user in a database along with the  
geographic locations of a plurality of other Internet users.
- 15 2. The method as set forth in claim 1, wherein the receiving one of the IP address  
or the domain name comprises receiving both the IP address and the domain name and the  
method further comprises verifying that the IP address corresponds to the domain name.

20

3. The method as set forth in claim 2, wherein the verifying comprises performing an nslookup on one of the IP address or domain name.

4. The method as set forth in claim 1, wherein the determining comprises performing a whois for the IP address.

5 5. The method as set forth in claim 1, further comprising checking whether the target host is on-line prior to determining the geographic address.

6. The method as set forth in claim 5, wherein the checking comprises performing a ping.

7. The method as set forth in claim 1, wherein the obtaining of the route through  
10 the Internet comprises performing a traceroute.

8. The method as set forth in claim 1, wherein the analyzing of the route comprises mapping the route to geographic locations stored in a database.

9. The method as set forth in claim 1, further comprising assigning a confidence level to the geographic location of the Internet user.

15

10. The method as set forth in claim 1, wherein the determining of the geographic location includes analyzing the domain name for the geographic location.

11. The method as set forth in claim 1, further comprising confirming the geographic location of the Internet user.

5 12. A method of providing geographic locations of Internet users to requestors, comprising:

collecting geographic locations on a plurality of Internet users and storing the geographic locations in a database;

10 receiving a query from a requestor for the geographic location of a particular Internet user, the query containing at least one of an IP address or a domain name for the particular Internet user;

determining whether the geographic location of that particular Internet user is available in the database;

15 if the geographic location is available in the database, delivering the geographic location on that particular Internet user to the requestor.

13. The method as set forth in claim 12, wherein if the geographic location is not available in the database, the method further comprises determining the geographic location of the particular Internet user and storing the geographic location in the database.

14. The method as set forth in claim 12, wherein the determining whether the geographic location is available in the database comprises sending a query to a remote database.

15. The method as set forth in claim 12, wherein the determining whether the  
5 geographic location is available in the database comprises sending a query to a local database.

16. The method as set forth in claim 12, further comprising selectively delivering information to the Internet user based on the geographic location of the Internet user.

17. The method as set forth in claim 12, further comprising selectively redirecting  
10 the Internet user based on the geographic location.

18. A method of tracking the behavior of Internet users based on their activities on the Internet, comprising:

obtaining geographic locations of a plurality of Internet users and storing the geographic locations in a database;

15 receiving queries from requestors for the geographic locations of a particular Internet user;

delivering the geographic location for that particular Internet user to the requestors;

tracking the requestors associated with that particular Internet user; and  
determining the behavior of the particular Internet user based on the associated  
requestors.

19. The method as set forth in claim 18, further comprising determining the  
5 geographic locations of the plurality of Internet users.

20. The method as set forth in claim 18, wherein the determining of the behavior  
comprises generating a profile for that particular Internet user.

21. A method of determining a geographic location of an Internet user that  
accesses the Internet through a caching proxy server, comprising:  
10 embedding an identifiable tag in a web page to form a tagged web page;  
in response to the Internet user requesting the web page and receiving a request for the  
web page from the caching proxy server, transmitting the tagged web page to the Internet  
user through the proxy server;  
opening a direct connection with the Internet user;  
15 communicating with the Internet user through the direct connection;  
receiving the identifiable tag from the Internet user;  
obtaining an IP address for the Internet user from use of the identifiable tag; and  
determining the geographic location of the Internet user.

22. The method as set forth in claim 21, wherein the embedding comprises tagging the web page with a Java applet.

23. The method as set forth in claim 21, wherein the identifiable tag comprises a unique applet parameter tag.

5 24. The method as set forth in claim 21, further comprising marking the web page as uncachable.

25. The method as set forth in claim 21, wherein the opening of the direct connection comprises accepting the direct connection through a port.

26. A method of determining a geographic location of an IP address on the  
10 Internet, comprising:  
obtaining an access number for an Internet Service Provider;  
connecting to the Internet Service Provider through the access number;  
determining an IP address provided by the Internet Service Provider;  
determining a route through the Internet;  
15 determining a geographic location of at least one point of presence for the Internet Service Provider by analyzing the route; and  
determining the geographic location of the IP address based on the geographic location of the point of presence for the Internet Service Provider.



27. The method as set forth in claim 26, wherein the obtaining of the access number comprises obtaining a dial-up number for the Internet Service Provider.

28. The method as set forth in claim 26, wherein the determining of the route comprises performing a *traceroute*.

5 29. The method as set forth in claim 26, further comprising storing the geographic location of the IP address.

30. A method for permitting information to be selectively delivered to Internet users, comprising:

10 compiling information on a plurality of Internet users and obtaining data related to the Internet users;

storing the information and data related to the plurality of Internet users in at least one database;

receiving a query from a requestor regarding a particular Internet user;

retrieving the data associated with that particular Internet user; and

15 transmitting the data to the requestor;

wherein the data permits the requestor to select desired content for that particular Internet user from a plurality of possible choices of possible content and to deliver the desired content to that particular Internet user.

31. The method as set forth in claim 30, wherein the database is a geography database and the data relates to geographic locations of the Internet users.

32. The method as set forth in claim 30, wherein the database is an authorization database and the data relates to the desired content the particular Internet user is authorized to  
5 receive.

33. The method as set forth in claim 30, wherein the database is a network speed database and the data relates to a down-load rate for the particular Internet user.

34. The method as set forth in claim 30, wherein the database is a profile database and the data relates to a profile of the particular Internet user.

10 35. The method as set forth in claim 30, wherein the database is an interface database and the data relates to an interface of the particular Internet user.

36. A method of determining a geographic location of an Internet user that accesses the Internet through a caching proxy server, comprising:  
associating a Java applet with a web page;  
15 in response to the Internet user requesting the web page and receiving a request for the

web page from the caching proxy server, transmitting the web page and associated Java applet to the Internet user through the proxy server;

opening a direct connection with the Internet user;

communicating with the Internet user through the direct connection;

5 obtaining an IP address for the Internet user; and

determining the geographic location of the Internet user.

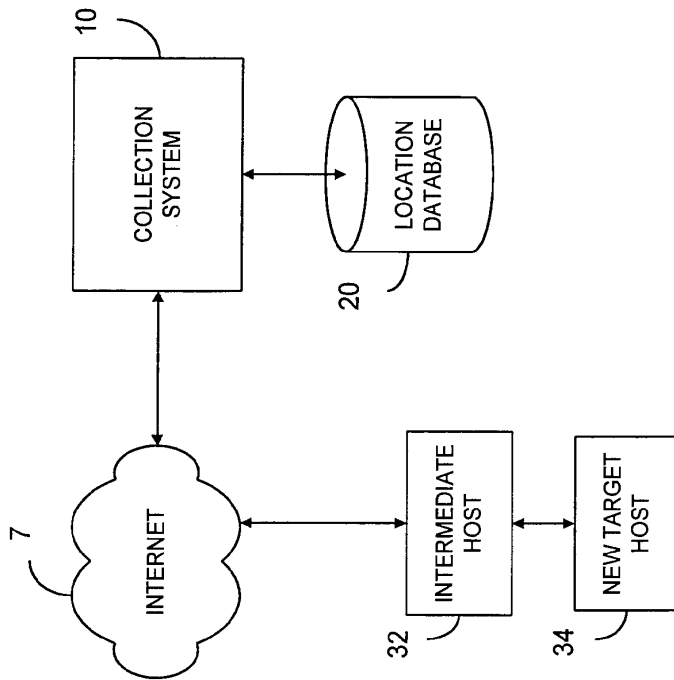


FIGURE 1

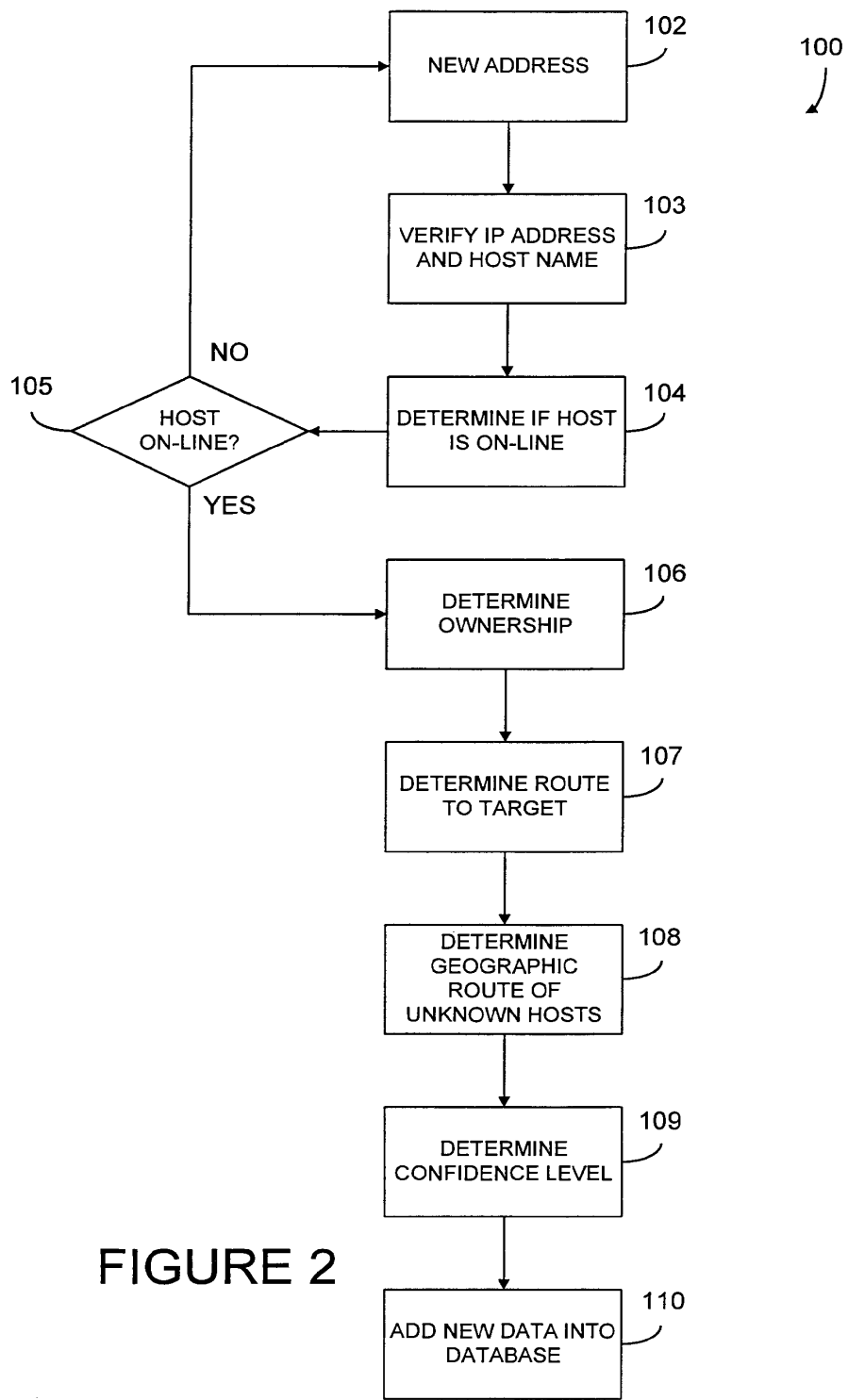


FIGURE 2

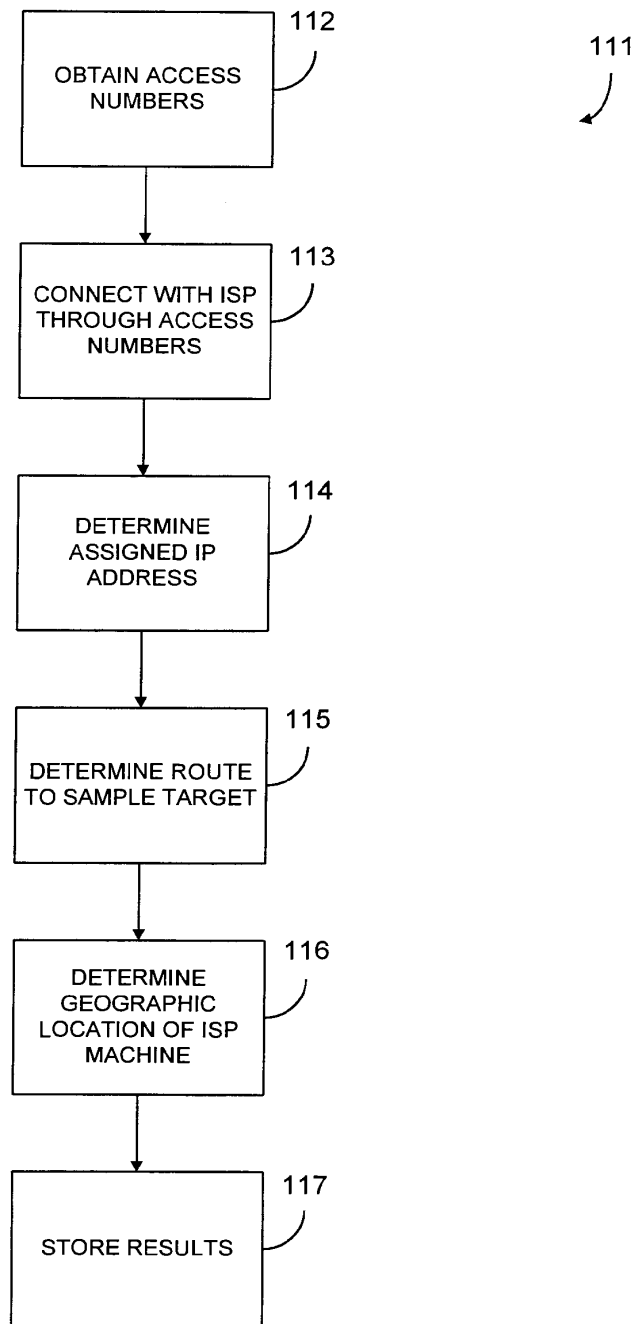


FIGURE 3

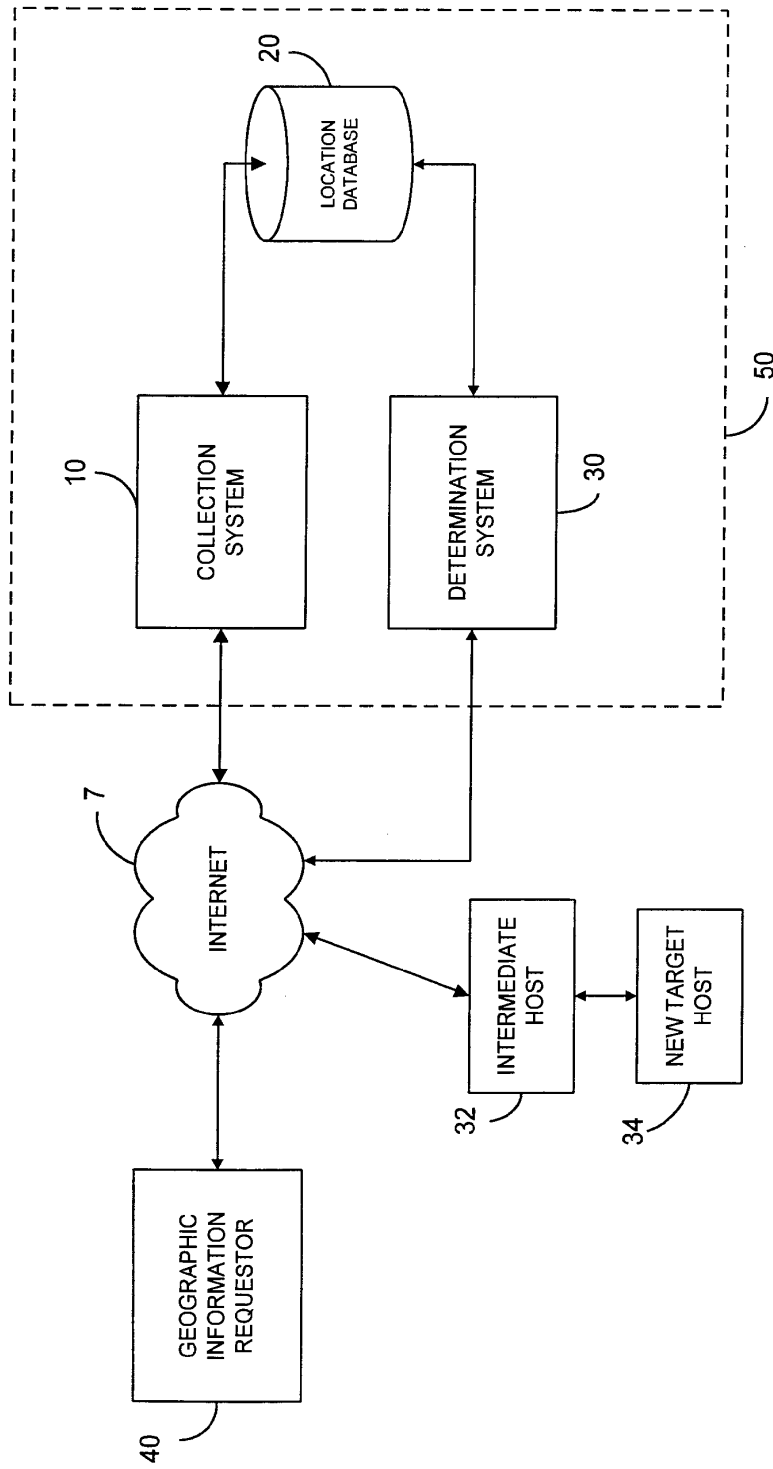


FIGURE 4

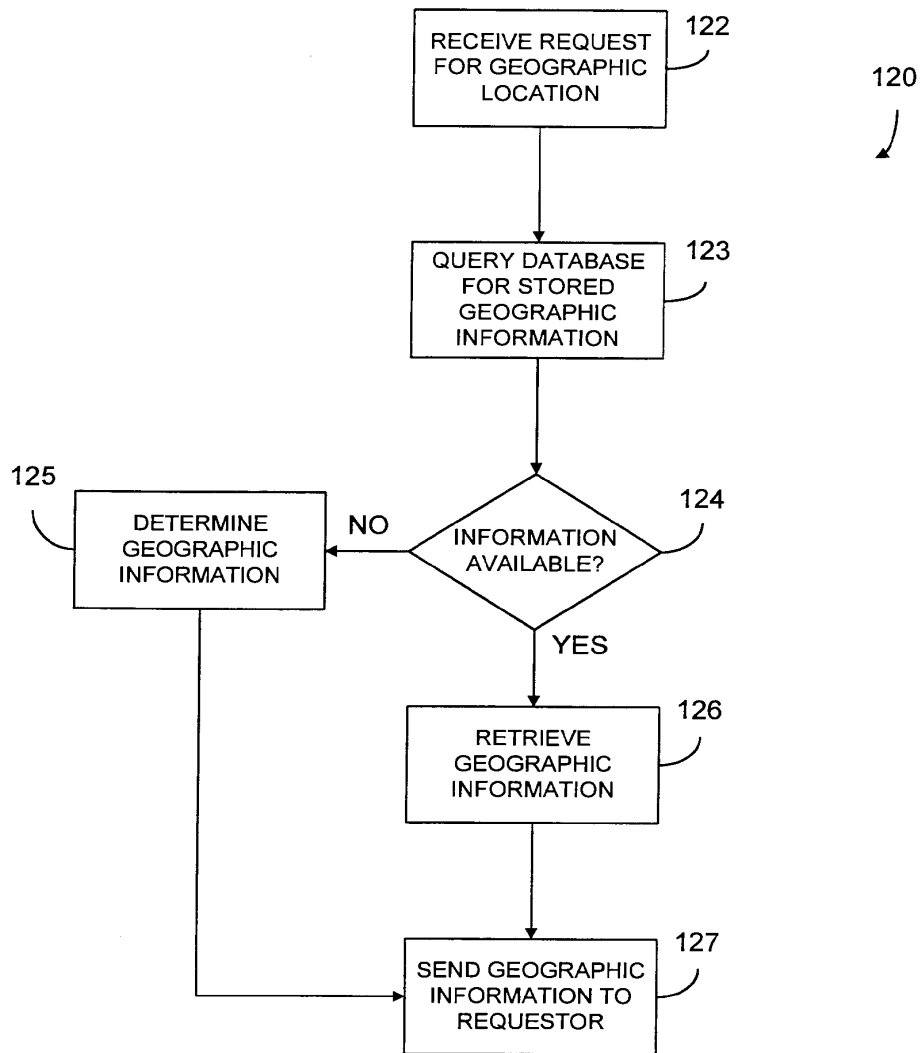


FIGURE 5



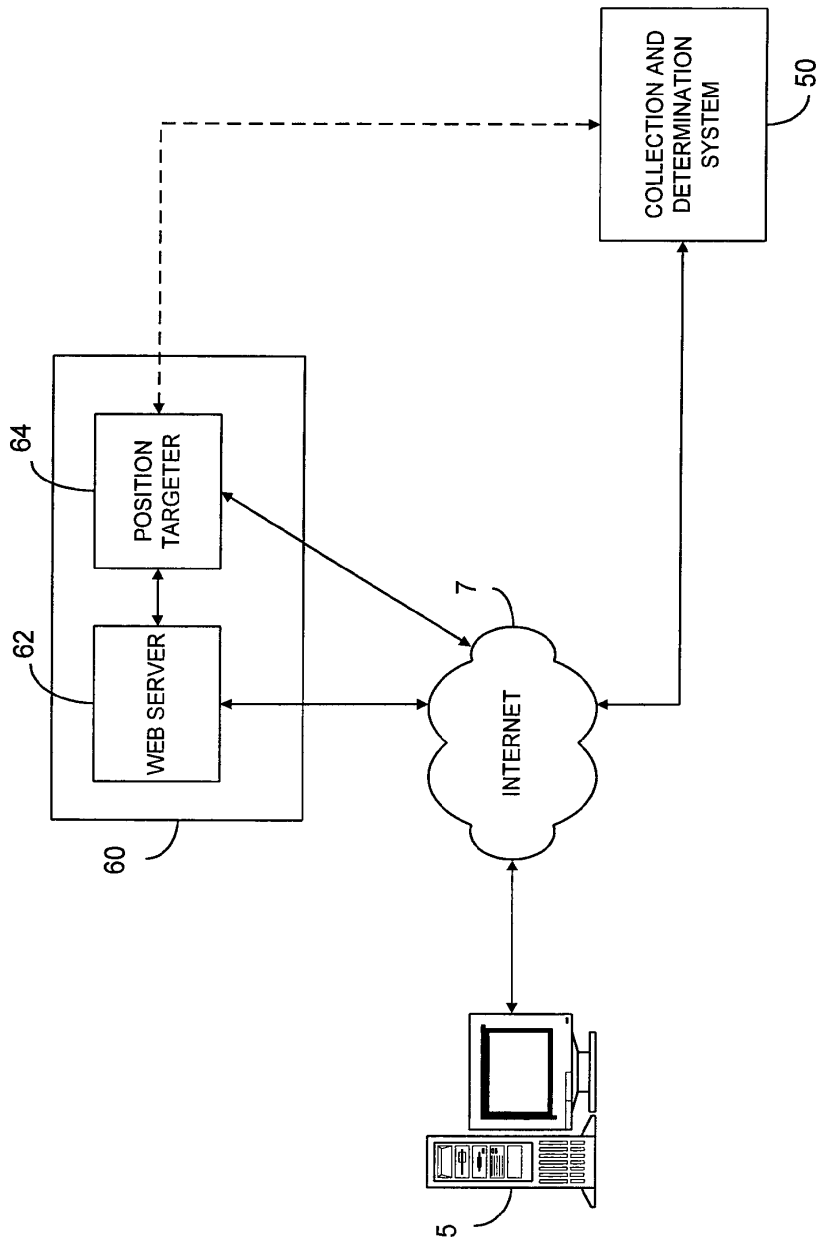


FIGURE 6

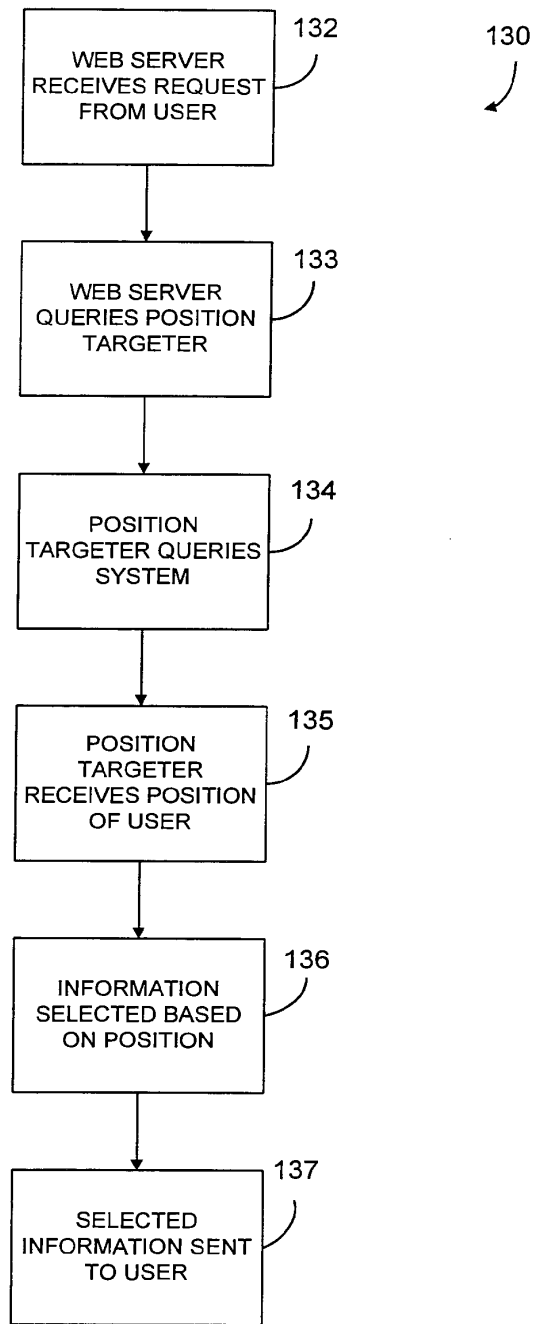


FIGURE 7

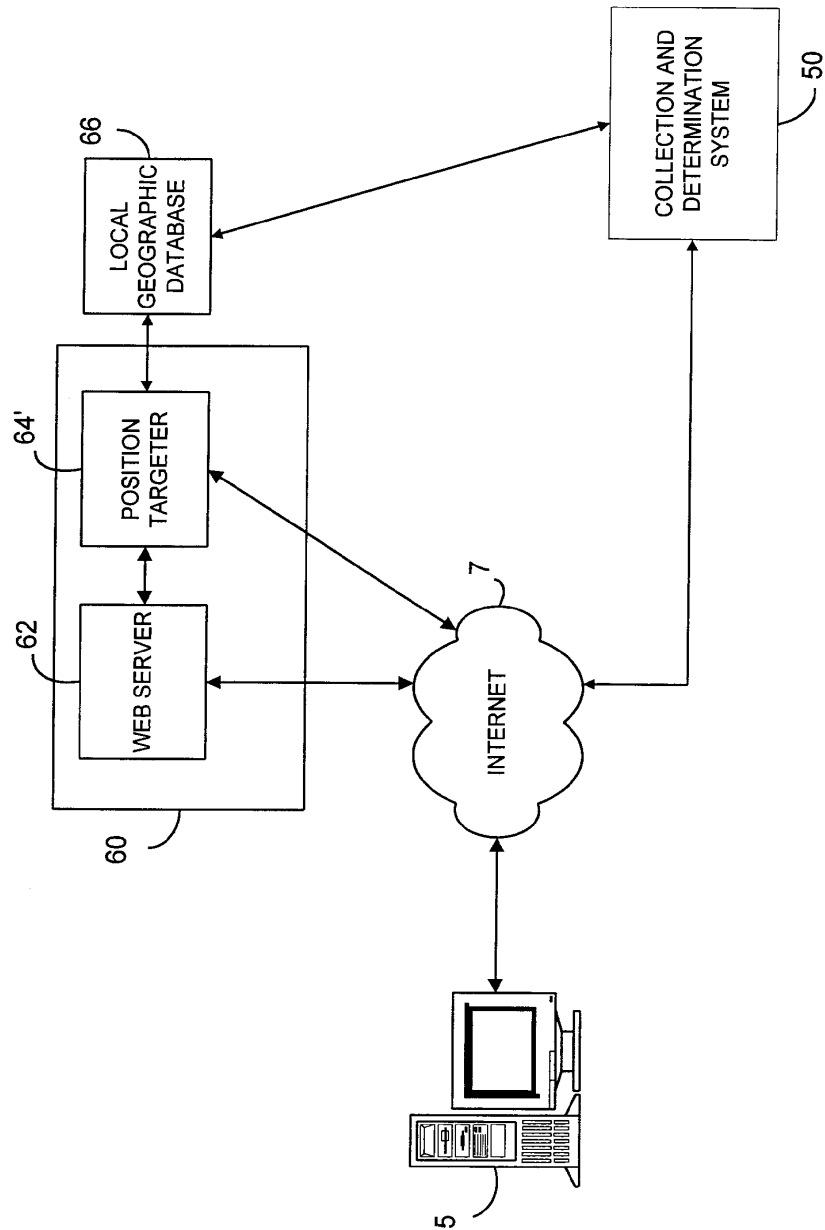


FIGURE 8

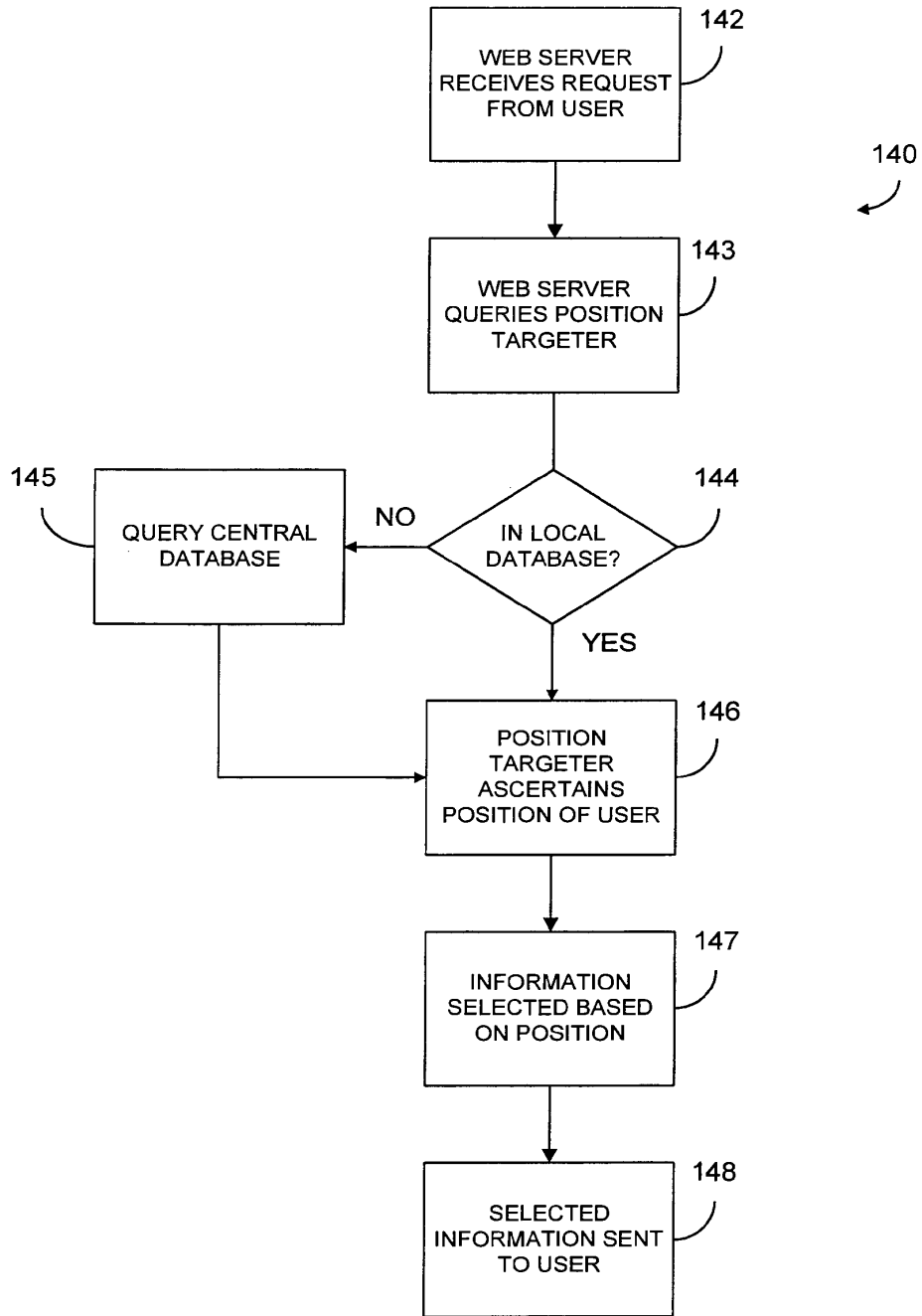


FIGURE 9

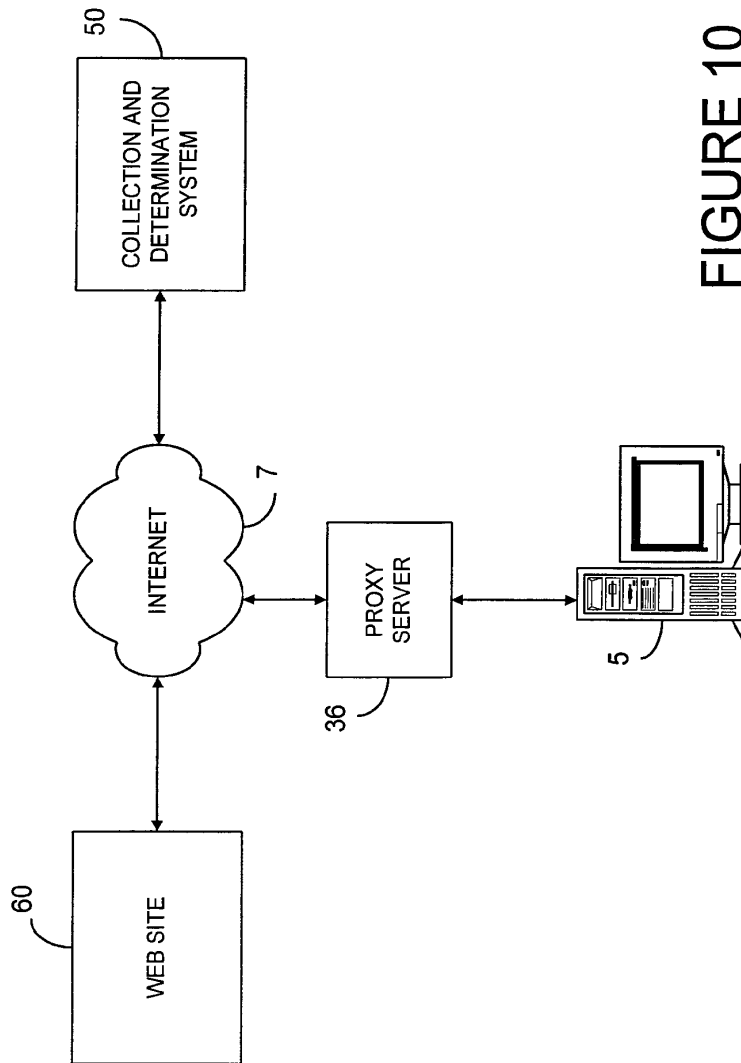


FIGURE 10

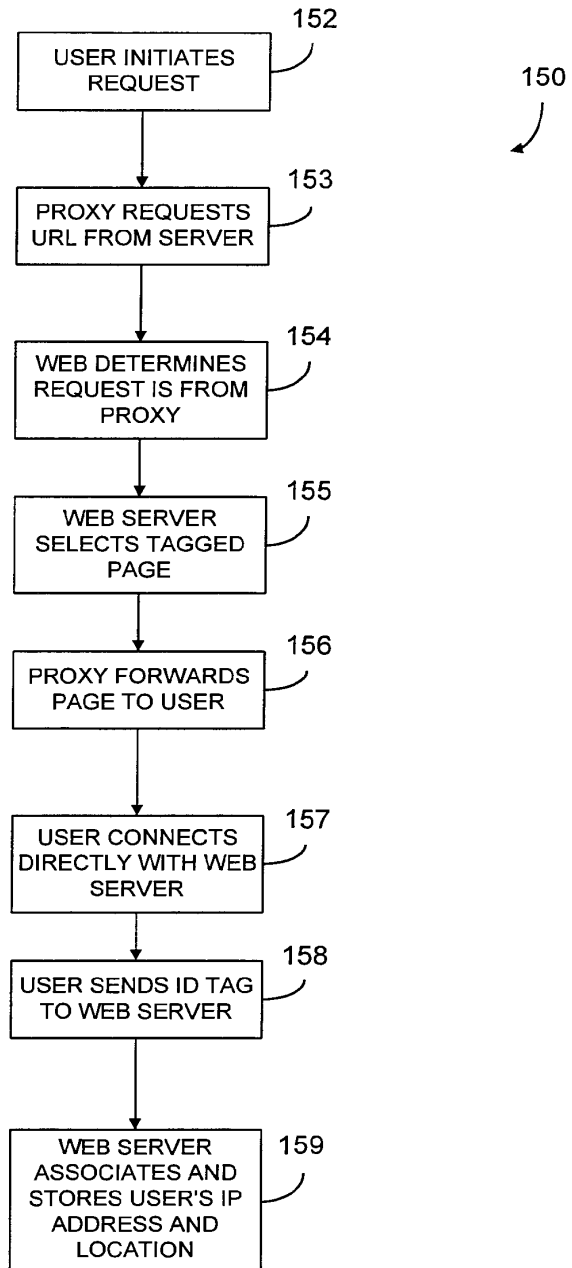


FIGURE 11

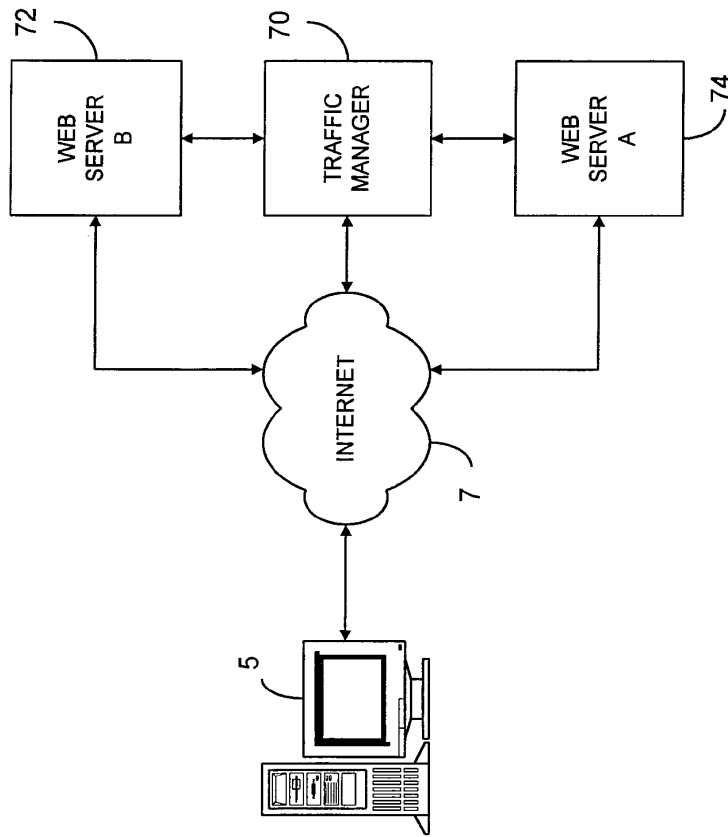
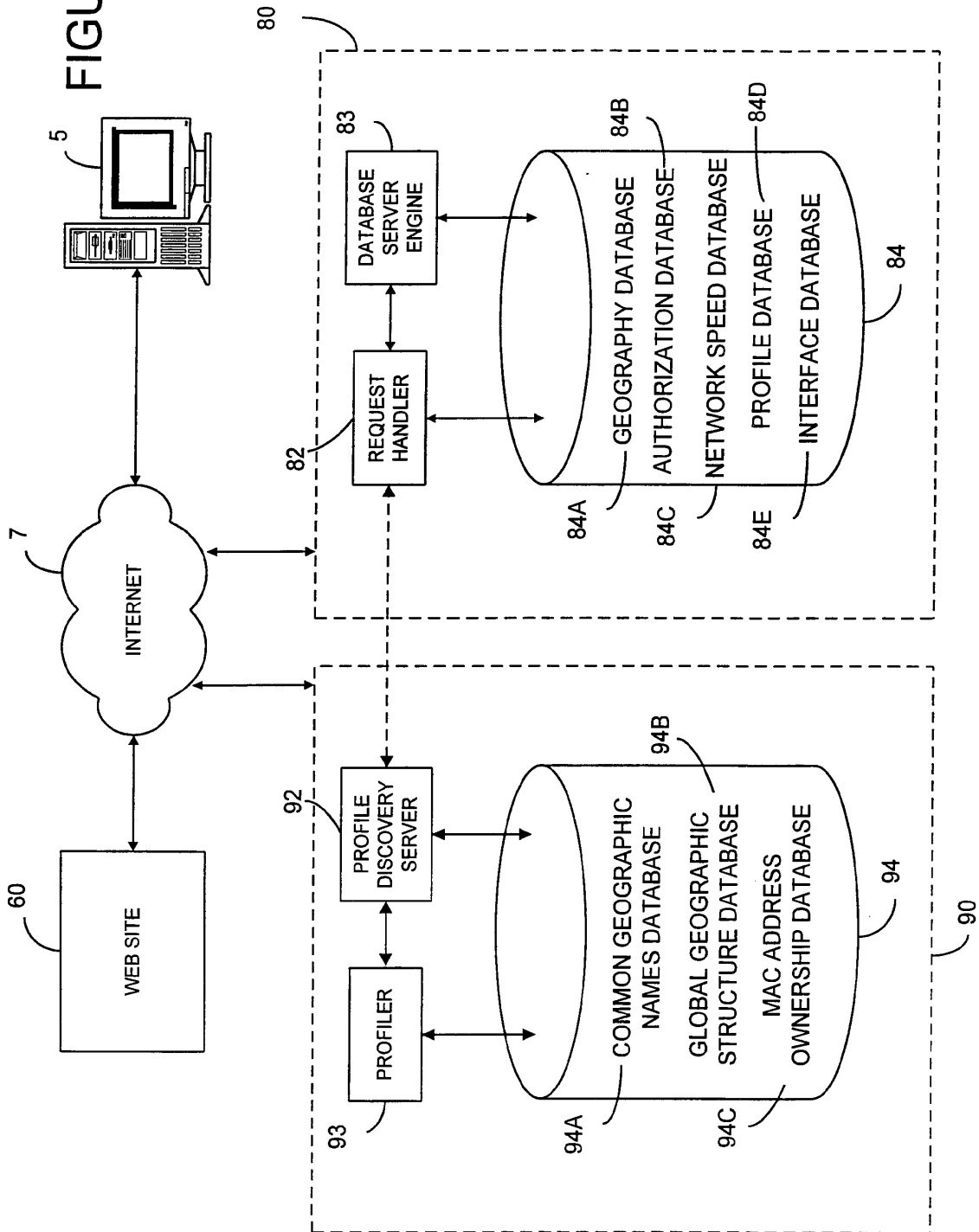


FIGURE 12

FIGURE 13





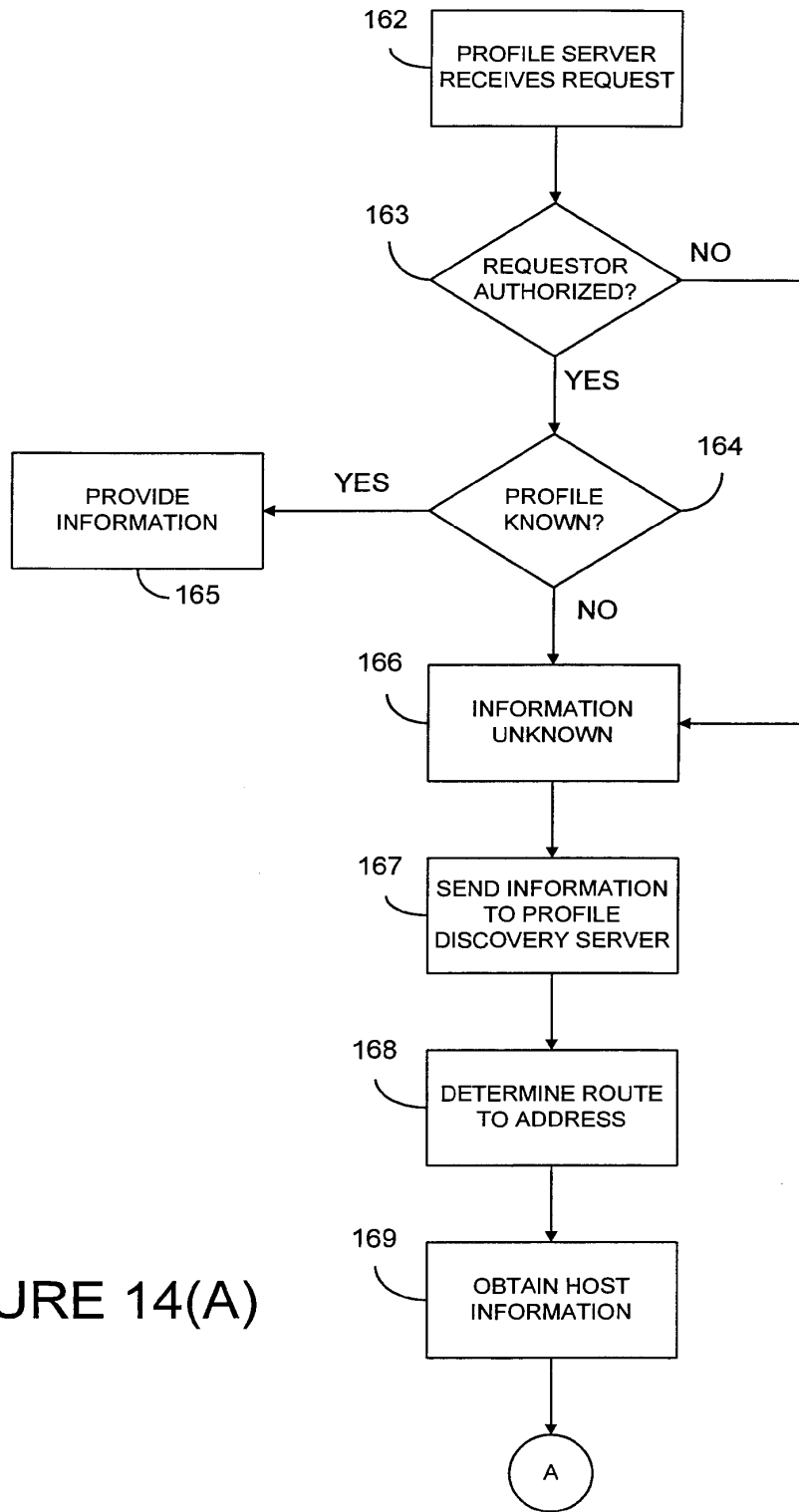
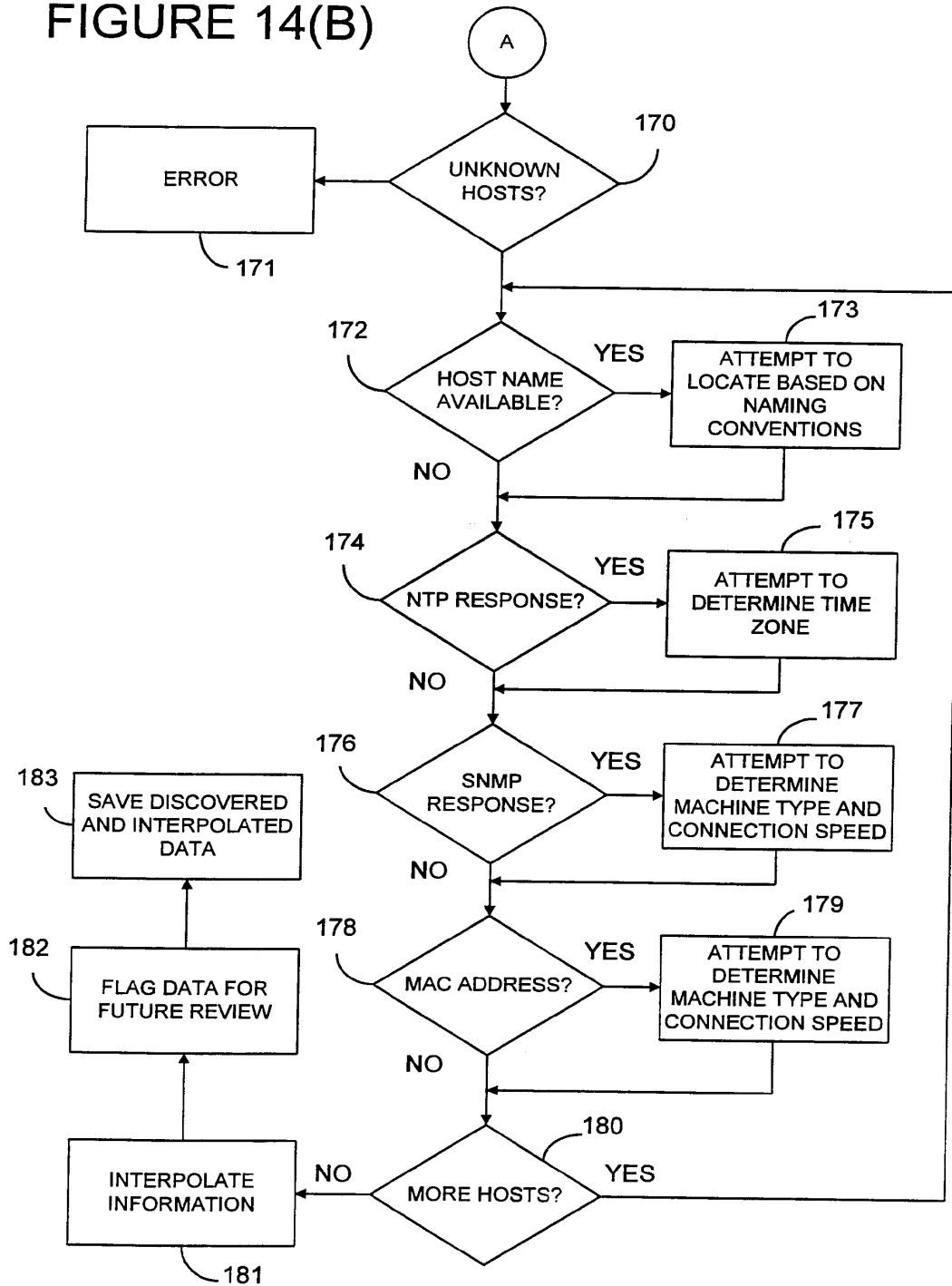


FIGURE 14(A)

FIGURE 14(B)





INTERNATIONAL SEARCH REPORT

International Application No  
PCT/US 00/11803

| C.(Continuation) DOCUMENTS CONSIDERED TO BE RELEVANT |   |                       |
|--|---|-----------------------|
| Category   | Citation of document, with indication, where appropriate, of the relevant passages  | Relevant to claim No. |
| P,Y  | WO 99 34305 A (KENNEY WILLIAM ;AMERICA<br>ONLINE INC (US)) 8 July 1999 (1999-07-08)<br>page 5, line 7 - line 16<br>page 6, line 27 -page 7, line 26 | 12-17,<br>30,31       |
| A  | ----  | 32-35                 |
| P,Y  | US 6 035 332 A (SHELTON JAMES A ET AL)<br>7 March 2000 (2000-03-07)<br>column 2, line 26 - line 59<br>column 4, line 38 -column 7, line 45          | 22,23,<br>25,36       |
| A  | ----  | 24                    |
| A  | US 6 012 088 A (COBBS ARCHIE L ET AL)<br>4 January 2000 (2000-01-04)<br>column 4, line 45 - line 65<br>column 9, line 25 - line 49<br>-----         | 26                    |

1

# INTERNATIONAL SEARCH REPORT

Information on patent family members

International Application No  
PCT/US 00/11803

| Patent document cited in search report      | A | Publication date | Patent family member(s) | Publication date |
|---|---|------------------|-------------------------|------------------|
| US 5948061                                  | A | 07-09-1999       | NONE                    |                  |
| <hr style="border-top: 1px dashed black;"/> |   |                  |                         |                  |
| WO 9934305                                  | A | 08-07-1999       | AU 1937599 A            | 19-07-1999       |
|   |   |                  | AU 1940199 A            | 19-07-1999       |
|   |   |                  | AU 2093099 A            | 19-07-1999       |
|   |   |                  | WO 9934555 A            | 08-07-1999       |
|   |   |                  | WO 9934306 A            | 08-07-1999       |
|   |   |                  | AU 2028199 A            | 26-07-1999       |
|   |   |                  | WO 9935815 A            | 15-07-1999       |
| <hr style="border-top: 1px dashed black;"/> |   |                  |                         |                  |
| US 6035332                                  | A | 07-03-2000       | EP 0908824 A            | 14-04-1999       |
|   |   |                  | JP 11249995 A           | 17-09-1999       |
| <hr style="border-top: 1px dashed black;"/> |   |                  |                         |                  |
| US 6012088                                  | A | 04-01-2000       | AU 3572697 A            | 03-07-1998       |
|   |   |                  | EP 0953248 A            | 03-11-1999       |
|   |   |                  | WO 9826548 A            | 18-06-1998       |
| <hr style="border-top: 1px dashed black;"/> |   |                  |                         |                  |

(12) INTERNATIONAL APPLICATION PUBLISHED UNDER THE PATENT COOPERATION TREATY (PCT)

(19) World Intellectual Property Organization  
International Bureau



(43) International Publication Date  
5 July 2001 (05.07.2001)

PCT

(10) International Publication Number  
**WO 01/48624 A1**

(51) International Patent Classification<sup>7</sup>: **G06F 15/16**,  
G08B 5/22

(21) International Application Number: PCT/US00/35250

(22) International Filing Date:  
22 December 2000 (22.12.2000)

(25) Filing Language: English

(26) Publication Language: English

(30) Priority Data:  
09/474,458 29 December 1999 (29.12.1999) US  
09/502,407 10 February 2000 (10.02.2000) US

(71) Applicant and  
(72) Inventor: **GLORIKIAN, Harry, A.** [US/US]; 49 Waverly  
St., Belmont, MA 02478 (US).

(74) Agent: **BOYS, Donald, R.**; P.O. Box 187, Aromas, CA  
95004 (US).

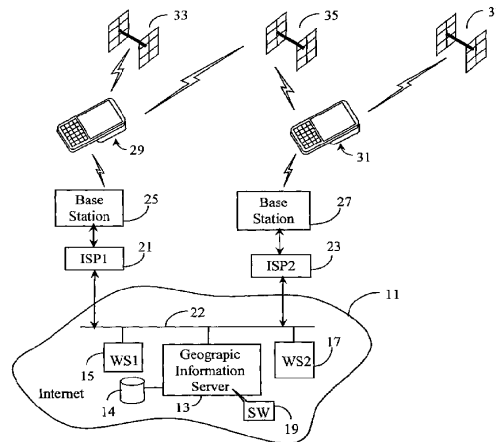
(81) Designated States (*national*): AE, AL, AM, AT, AU, AZ,  
BA, BB, BG, BR, BY, CA, CH, CN, CR, CU, CZ, DE, DK,  
DM, EE, ES, FI, GB, GD, GE, GH, GM, HR, HU, ID, IL,  
IN, IS, JP, KE, KG, KP, KR, KZ, LC, LK, LR, LS, LT, LU,  
LV, MA, MD, MG, MK, MN, MW, MX, NO, NZ, PL, PT,  
RO, RU, SD, SE, SG, SI, SK, SL, TJ, TM, TR, TT, TZ, UA,  
UG, UZ, VN, YU, ZA, ZW.

(84) Designated States (*regional*): ARIPO patent (GH, GM,  
KE, LS, MW, MZ, SD, SL, SZ, TZ, UG, ZW), Eurasian  
patent (AM, AZ, BY, KG, KZ, MD, RU, TJ, TM), European  
patent (AT, BE, CH, CY, DE, DK, ES, FI, FR, GB, GR, IE,  
IT, LU, MC, NL, PT, SE, TR), OAPI patent (BF, BJ, CF,  
CG, CI, CM, GA, GN, GW, ML, MR, NE, SN, TD, TG).

Published:  
— With international search report.

For two-letter codes and other abbreviations, refer to the "Guidance Notes on Codes and Abbreviations" appearing at the beginning of each regular issue of the PCT Gazette.

(54) Title: AN INTERNET SYSTEM FOR CONNECTING CLIENT-TRAVELERS WITH GEOGRAPHICALLY-ASSOCIATED DATA



(57) Abstract: A multi-dimensional information repository (19) has a plurality of stored data structures (14) and one or more tags associated with individual ones of the plurality of data structures. The data structures are tagged according to locations and defined regions relative to the surface of the Earth and a data retrieval system (13) retrieves information from the data structures (14) according to location data accompanying requests for data. In some cases, data structures are also tagged relative to time in addition to location and defined regions and both tags are used in retrieving data structures. An Internet (11) connected subscription server system (22) using the data repository has a communication module for receiving data requests accompanied by location data and a code set for managing retrieval of information from the data repository (19) in response to the data requests.

WO 01/48624 A1

**An Internet System for Connecting Client-Travelers with  
Geographically-Associated Data**

5

**Field of the Invention**

The present invention is in the field of Internet services and business models, 10  
pertains more particularly to apparatus, methods, and models for providing a service  
tracking geographic location of clients of the system, and providing information to the  
clients based on the tracked location.

**Background of the Invention**

15

The well-known Internet and the subset of the Internet known as the World  
Wide Web (WWW) is arguably the greatest present net repository and source of  
information available to persons enabled by suitable equipment to and connect to  
myriad Internet servers and download information. Enabling equipment for end users  
20 includes all computerized machines capable of establishing an Internet connection and  
of asserting addresses known as Universal Resource Locators (URLs) to connect to  
individual servers and pages on servers (Web pages), and of communicating in the  
language of the Internet. Such enabling equipment may be broadly termed Internet  
appliances, and include in aggregate large Internet-connected servers (which may be  
25 enabled to browse and connect to other Internet servers), desk-top personal  
computers, which typically connect to the Internet through telephone lines and Internet  
Service providers (ISPs), Web TVs, computerized set-top boxes typically using cable  
services for connection, and a wide variety of portable computerized units (portable  
computers).

30 The latter category of portable computers is of primary interest in the present  
invention, and includes an increasingly diverse set of equipment taking a variety of

- 2 -

names. Among these are laptop computers, palmtop computers, hand-held computers, personal digital assistants (PDAs), personal organizers, cellular telephones, and many more. To fall into the class of Internet appliances it is only required that such portable units be enabled to connect somehow to the Internet backbone, and be able to browse  
5 the Internet through some level of executable software, which ability may be enhanced or largely provided by Internet-connected proxy machines.

The Internet and Internet-related enterprise services, as of the time of the present patent application, have been growing at a very great rate, and one important reason for emergence of many new services is the sheer volume and resulting  
10 granularity of the Internet. A person accessing the Internet can be reasonably assured that the information he or she might seek is out there somewhere. Finding it, however can be another matter entirely.

A broad variety of services have been developed to help individuals locate information on the Web, among them quite sophisticated browser software executable  
15 on the end-user's Internet appliances, powerful search engines available on proxy servers to browse for subscribers and other clients, and indexing and listing services which attempt to track and cross-reference Internet information sources. For the purposes of the present specification, a client is a person who uses a service, while a subscriber is a client who registers and/or pays for using a service

20 Even with enormous effort going into new and better indexing and searching services, partly because of the rate of growth of sources and end users as well, there has been but little improvement in ability to quickly find and easily access information on the Web. Browsing the Internet can still be a daunting task, especially for the relatively uninitiated client. The present inventors have recognized, therefore, a need  
25 to narrowly focus information services to provide highly specialized information specific to needs and specialized interests of groups of individual clients, and automatically or semi-automatically provided to such clients.

30



- 3 -

**Summary of the Invention**

In a preferred embodiment of the present invention a multi-dimensional information repository is provided, comprising plurality of stored data structures; one  
5 or more tags associated with individual ones of the plurality of data structures; and a data retrieval system. The repository is characterized in that data structures are tagged according to locations and defined regions relative to the surface of the Earth, and the retrieval system retrieves information from the data structures according to location data accompanying requests for data. In some cases individual ones of the plurality of  
10 data structures are tagged according to time in addition to location and defined regions, and both tags are used in retrieving data structures. Individual ones of the plurality of data structures may be tagged according to human interest categories in addition to locations and defined regions and time.

In another aspect of the invention an Internet-connected subscription server  
15 system is provided, comprising a data repository having data structures tagged according to locations and defined regions relative to the surface of the Earth; a communication module for receiving data requests accompanied by location data; and a code set for managing retrieval of information from the data repository in response to the data requests. This system, receiving a data request, uses the location data  
20 accompanying the request to determine location in individual ones of pre-defined regions, and uses the pre-defined region information to access data structures and retrieve information related to the pre-defined regions for transmission in response to the data requests.

In some embodiments of the system data structures are tagged according to  
25 time data in addition to location, data requests include time data, and the system accesses data structures in part according to the time data. In some preferred embodiments the system maintains subscriber information profiles, including subscriber interests, data requests identify individual subscribers, data structures are tagged according to interest categories, and the system accesses data structures in part  
30 according to the stored interests of the subscriber initiating a data request.

- 4 -

In yet another embodiment the data repository is a first data repository local to the Internet server, and the system, though the code set, accesses remote Internet-connected information sources, and retrieves information from said remote sources according to one or more of stored client interests and the location data accompanying the client's request.

### **Brief Description of the Drawing Figures**

Fig. 1 is a block diagram illustrating an exemplary architecture for a service and business model according to a preferred embodiment of the present invention.

Fig. 2 is a diagram of basic elements of an Internet appliance of Fig. 1.

Fig. 3 is a plan view of an indoor exhibition facility in an embodiment of the present invention.

Fig. 4 is a logic flow diagram illustrating steps in practicing the invention in preferred embodiments.

Fig. 5 is a block diagram illustrating a configuration interface to a database according to an embodiment of the present invention.

Fig. 6a is a timing diagram illustrating steps in information access according to an embodiment of the invention.

Fig. 6b is a timing diagram illustrating steps in information access according to an alternative embodiment of the invention.

Fig. 7 is a block diagram illustrating architecture for accessing and using the database in embodiments of the invention by a relatively fixed device, such as a PC.

### **Description of the Preferred Embodiments**

Fig. 1 is a block diagram illustrating an exemplary architecture for an Internet-implemented service and business model according to a preferred embodiment of the

- 5 -

present invention. In this system a service is provided on an Internet-connected server 13 in the well-known Internet network represented by cloud 11. The service provided is particular to travelers, such as, for example, tourists, who are enabled typically with unique, hybrid hand-held units that are capable of informing server 13 regarding  
5 specific geographic location of the units, and therefore the person (client) using each unit.

In Fig. 1 two client's appliances 29 and 31 are represented as portable, hand-held computer units. In this embodiment each of units 29 and 31 are Palm™ hand-held computers enabled to connect to the Internet through integrated cellular telephone  
10 equipment via base stations. Unit 29 connects through base station 25 and ISP1 21 to Internet backbone 22, which represents all of the loosely defined interconnections of nodes and servers worldwide.

Base station 25 represents many base stations in a cellular telephony provider's network of such stations enabling cell user's to connect typically to a public switched  
15 telephone network (PSTN), hence to an ISP and to the Internet backbone. In some cases the cellular provider may provide the ISP service directly. The skilled artisan will recognize this diagram is exemplary, and will be aware of the various ways this wireless connection may be implemented.

In an alternative embodiment connection to the Internet for units 29 and 31 and  
20 similar units is provided through a Wireless Internet Protocol (WAP) technology, using systems and protocols according to the new WAP cooperative industry standard. In the WAP technology the wireless devices, such as units 29 and 31 connect wirelessly to a WAP-enabled service provider (WAP-SP) connecting to the Internet. In this embodiment server 31 enables according to the present invention could be integrated  
25 as a WAP-SP, or could be a separate server in the Internet accessible by the WAP-SP.

Unit 31 in the present example connects to Internet backbone 22 via representative base station 27 and ISP2 23, but in alternative embodiments could connect through WAP technology as described above. As users of units 29 and 31 move about geographically, as long as the units are on and powered, wireless

- 6 -

connection may be maintained by connection through different stations in the cellular provider's base station network.

Fig. 2 is a block diagram of internal elements of hand-held unit 29 of Fig. 1, including exemplary connectivity. The present invention pertains most particularly to portable computing units, of which there are many varieties, as described above in the background section. In a preferred embodiment unit 29 is a modified or enhanced Palm™ hand-held computer device. In this preferred embodiment the unit has cellular telephone circuitry which serves as a connection path for Internet communication, and this combination is known in the art.

Unit 29, as shown in Fig. 2 has a central processing unit (CPU) 39 and a system memory 41 communicating on an internal bus 67. The CPU and the nature of the memory will vary depending upon the nature of unit 29. The CPU, for example, may be an Intel Pentium™ microprocessor if unit 29 is a portable laptop computer. memory 41 may include read-only memory (ROM), such as a basic input-output system (BIOS), random access memory (RAM) for temporary storage, and non-volatile memory such as a hard-disk drive or a flash memory, or any combination of known memory-storage apparatus.

In a preferred embodiment a cellular telephone circuitry 43 connected to bus 67 and operating through an antenna 45 provides connection to a public switched telephone network (PSTN) through a cellular telephony provider's network as described above, hence to an Internet service provider such as ISP1 or ISP2 of Fig. 1, to Internet backbone 22 (also Fig. 1). Unit 29 is enhanced with Internet browser software (not shown) to be able to access and browse the Internet world. In some embodiments the browser software is a commercially available product, and in other embodiments may be an available browser enhanced with one or more plug-ins according to embodiments of the invention, and in yet other embodiments may be wholly provided as unique software according to embodiments of the present invention. In some embodiments the browsing will be done principally at the network (source) end, and data presentation at the hand-held unit will be by other than browser technology.

- 7 -

In some embodiments conventional telephone circuitry 53 is provided connected to a telephone connector 56, for Internet access, and this circuitry may be in addition to or in lieu of circuitry 43. For example, a laptop computer enabled to practice the present invention may have only circuitry 55, comprising a data modem and, in some cases voice circuitry as well, while a Palm™ implementation may have only the cellular connection apparatus.

Common to most implementations of unit 29, there will be display driver circuitry 63 and a display 65, for displaying information from Internet sources as well as for performing other routine output functions, and a user input interface 59 and input apparatus 61. Input apparatus 61 comprises, for example, a keyboard and a pointer device. In some embodiments of unit 29 there will be one or both of a microphone and speaker circuitry 47 and one or both of a microphone 49 and a speaker 51. It is also important to understand that many implementations of client units such as units 29 and 31 may have more or fewer elements than shown in Fig. 2.

Common to all examples of units 29 and 31, there is a GPS circuitry 57 for receiving signals from multiple GPS satellites and for determining a location for the unit from the satellite signals. Such GPS systems are known in the art, but not necessarily in combination with other elements as disclosed herein. GPS system 57 communicates on bus 67, and the net effect is, that in operation, the geographic position of unit 29 on the Earth's surface, accurate to within a few feet at the most, is available to CPU 39 at all times that the unit is in operation.

In some (OEM) embodiments of the invention the GPS apparatus is integrated into the circuitry of the portable units. In others, an add-on GPS unit is provided that may be attached to and connected to an existing portable unit already having the cell-telephone capability or other Internet connectivity. In still other cases an add-on unit may be provided that adds cell-telephone capability and GPS capability to an existing portable computing unit that has neither capability. Such add-on units may connect through a standard serial port, a universal serial port (USB), a parallel port, such as the port typically used for printers, and so on. Physical attachment may be made in a number of ways so the resulting assembled unit is convenient to use.

- 8 -

In practice of a preferred embodiment of the present invention specific information is transmitted (downloaded) from, through, or initiated by Internet server 13 in response to requests from a portable unit (29, 31), the request in preferred embodiments is accompanied by global positioning data defining the global position of the requesting unit. In a preferred embodiment the portable unit (29, 31) is enhanced with software 42 that, among other duties, accesses the Internet and asserts the URL of server 13 when the unit is powered on. In the case of WAP technology, this access may be wireless access to a WAP-SP. Thenceforth periodic requests are transmitted from the portable unit along with GPS position, updating the info to server 13. In other embodiments software 42 may provide a user interface allowing the user to select the service of the present invention, such as by selecting an icon on a desktop screen, as is known in the art, to initiate the service of the invention.

Software 42 operating on the user's appliance may take many forms, and may have many functions and duties, many of which are described in more detail below. This software, in general, is fashioned to provide a user interface and information presentation functions particular to the embodiments of the invention.

It will be apparent to the skilled artisan that requests from portable units may be identified as specific to individual units (ID) in several ways. The typical protocol for such requests, for example, includes transfer of a *cookie* which may identify the individual unit, the cookie having been provided by the service to the client unit at the time of initial log-in. Processes and protocols for log-in and authentication are well-known in the art, and new processes are being developed to make the process more secure as well as more transparent to the user.

Referring now back to Fig. 1, a client using unit 29, for example, moving about geographically, with unit 29 on and operating, is connected to server 13 through Internet backbone 22, which represents all of the loosely defined Internet connection and interconnection pathways. Server 13 may have local access to a data repository 14 of any convenient type and size, upon which may be stored any convenient information. Server 13 also has access through backbone 22 to the rest of the Web,

- 9 -

represented by Web servers WS1 15 and WS2 17, which may have access to other databases and yet other repositories.

In a preferred embodiment a service is provided to such as tourists and other travelers, wherein information of, for example, historical interest is stored accessible to  
5 server 13 and indexed by global position, and in some cases also by dynamics of global position.

As an example of such a service, a tourist, also a client of a service according to an embodiment of the present invention, may be making a walking tour of Colonial Williamsburg in the U.S. state of Virginia. Colonial Williamsburg, as is well-known, is  
10 a superbly-maintained historical site presenting buildings and artifacts pertaining to the original settlements by Western Europeans along the James river in Virginia, and includes the Jamestown colony, first peopled during the reign of James the First of Britain in the early part of the 17th century, considerably prior to the landing of the pilgrims at Plymouth in the state of Massachusetts. The landing of the pilgrims, by the  
15 way, occurred on the outer island of Cape Cod, and these pilgrims were originally bound for the Jamestown site.

This tourist, for example, may be presented with information pertaining to items of very local interest. The tourist, a client of the enterprise host of server 13, may be walking along the James river on the plot known as Martin's Hundred, which  
20 was established in 1617 by a group from London, arriving on the ship *Guift of God*. This client will be pushed information about the history of Martin's Hundred, the people who participated, and what happened there.

In a preferred embodiment, because GPS positioning is quite accurate, down to at most an error of less than three feet, the granularity of the information selection can  
25 be quite high. For example, as the client walks or rides in broad areas of Martin's hundred not immediately adjacent to any specific, more limited (lower-level) historical site, information of a general nature is pushed to the client's portable device. As the client nears John Boys' house on the banks of the James river, specific information about John Boys (who was titular head of Martin's Hundred for a time) and his family  
30 will be pushed. As the client walks toward a trash pit near this site, where

- 10 -

archeologists have discovered the remains of a servant of the Boys household, who crawled there, grievously injured, during the Powhatten uprising in the early 1620's, hid under the refuse, and died there of her injuries, details of the Indian uprising may be pushed, along with details of this archeological site.

5           The historical information pushed under these circumstances may be selected by software at server 13 based on more than the simple location of the portable unit. The direction of change in location may be used as well, and the rate of change, and other dynamics derivative from location and time. The information pushed, for example would be different if the client walks toward the rubbish site from the Boys'  
10 house, as opposed to walking from the rubbish site towards the house. In the first case the info would be about the rubbish site, and associated information, and in the second about the house and its occupants, even though the actual GPS position may be the same. The use of the dynamic data in information selection and granularity is unique.

          As an example of a use of rate of change, a client at Martin's Hundred might  
15 well move from site to site on an electric cart, or by automobile, and walk around at each site. In such a case, the software at server 13 may present information quite differently. If the client is seen to be moving at a rate consistent with a vehicle, the service can provide site-to-site information, scripted also by direction of movement. If the client is seen to be moving at a walking rate, the information is more granular and  
20 specific, related to an individual site, and so forth.

          There are many variations in practicing the invention that may depend, for example, on the nature of the client's Internet appliance (that is, its capabilities and characteristics), and this client-profile information may be available to the service at server 13, and be accessed to determine what to push to a client, and how to push it.  
25 For example, in some embodiments a client may be using a laptop computer connectable to the Internet only through a standard telephone connector and modem. The laptop computer in this case, of course, in preferred embodiments of practice of the invention, is enabled by a GPS system, so, when connected to server 13, the laptop reports its position. If the client is a subscriber, the client's profile, stored at server 13,



- 11 -

will indicate the nature of the laptop and connectability, and information will be selected and pushed at a relatively high and general level, as suitable for the situation.

A lot of detail about the nature of historical information to be made available to clients is not necessary in this specification. The volume of such information,  
5 concerning civil war sites, genealogical sites and information, historical sites in other parts of the world (Western Europe, for example, and much more, is readily available to imagination of the skilled artisan.

Information to be indexed by geography (location) is certainly not limited to historical information, but extends to many other kinds of information, and the type of  
10 information to be provided may be selectable by a client. Archeological information may be provided, including information about local geography, mineral deposits, water supplies and the like. Information about local government offices, local cemeteries, local museums and exhibition sites, and so forth may be prepared and made available to clients. Another information shell could be organized around economic information,  
15 such as local industry, small businesses, and the like. Historical data about a region may be organized around not only geographical position, but relative to time as well. For example, all sorts of data as mentioned above may be provided for any different period of time (era) that a client may desire. There are thus a vary great variety of information shells and granularity relative to geographic position, time frame, and real  
20 time that may be organized and made available to clients. All such data is organized in the provider's database, or in databases accessible to the host of the service. It is an object of the invention to make information available to clients on a basis of the individual client's interest as well as geographical and time dimensions.

It was described above that portable units to practice the present invention may  
25 vary widely in components and architecture. The mode in which information is provided may, in many cases, be strongly influenced by the architecture of the units used. In many cases, for example, information downloaded to field units will be presented to the user in audible mode. This may be done in any of several ways. For example, in some cases the portable field unit may have text-to speech software, and  
30 downloaded text is converted at the unit to synthesized speech. In other cases, text

- 12 -

may be displayed; along with graphics in some cases as well. In yet other embodiments information to a client in the field may be sent in analog or digital audio format, and rendered audible through the circuitry and speaker system at the field unit.

5 **Indoor Application Embodiments**

It is well-known that presently-available GPS systems are workable only out-of-doors, while cellular telephone systems typically work quite well indoors. This is in part because signals from satellites are diffuse, and therefore the signal strength at any  
10 point on the Earth's surface is relatively low, while cellular telephone and other wireless protocol signals are much stronger. It is also well known that many sites of interest to tourists and travelers, where information may well be organized by location, are inside buildings where GPS may not be serviceable directly.

As an example of an indoor exhibit where an embodiment of the present  
15 invention would be quite useful, consider the Metropolitan Museum of Art in Manhattan, NYC, on the upper East Side (about 81st and Fifth Avenue on the Central Park side). This museum is in very large buildings and typically has a large number of exhibits for divergent interests. There are, for example, collections of armor and weaponry, collections of paintings organized by type, by artist, and in other ways,  
20 visiting collections of art and artifacts from other countries and cultures, and so forth. For the purposes of this invention, information about all of the exhibits at this museum may be indexed according to geographic location in the buildings, which may be accessed selectively if one has a portable unit requesting such information from a database while simultaneously reporting the device's relatively precise position in the  
25 museum.

Fig. 3 is a plan view of a simple, exemplary indoor exhibiting site 69 with indoor exhibits organized in specific locations within the site, according to an embodiment of the present invention. There is an entrance/exit in this example, and there are three exhibit rooms, as shown in the figure. Exhibits in cases A through J are  
30 arranged in rooms 1 and 3, and paintings (1) through (14) are hung on the walls of

- 13 -

room 2. All exhibits may be documented in an information database by location from an arbitrary reference point, such as point 0 as shown at the upper left corner of site 69. This is a simple Cartesian reference system listing locations of exhibits in two dimensions from reference point 0. In other embodiments there may be a three-  
5 dimensional reference system, allowing for differentiation of exhibits on multiple levels of a multi-storied exhibit site, or any known sort of planar or spatial reference system.

In this embodiment of the invention a secondary communication link is opened between Internet appliance 71 and a location system 73 provided by the host of the indoor exhibit. The purpose of this communication is to establish the position and  
10 dynamics of movement of a user of appliance 71 within the confines of the indoor exhibit. The skilled artisan will recognize that there are alternative ways this may be done. In one embodiment a secondary receiver is provided in appliance 71 receiving on an RF frequency common to sending equipment used for the purpose by cooperating enterprises that host indoor exhibits. This receiver is represented in Fig. 2  
15 by secondary receiver 77. Multiple stations within the exhibit premises may be used with triangulation techniques for tracking movement of users, for example. In another alternative embodiment there may be small transmitters of limited range at strategic points within the exhibit premises, and the appliance may determine its position according to signals received by secondary receiver 77, much as a GPS system does.

20 Within the indoor facility appliance 71 with secondary receiver 77 communicates with station 73 via antenna 75 and circuitry 79. This facility is meant to be representative of any wireless indoor system capable of locating a user's appliance relatively precisely within an indoor facility.

In one embodiment the secondary position system simply determines the  
25 position of the user of appliance 71 within the exhibitors facility, and this information is passed to server 13 on the Internet. Server 13 is informed not only of this position, but of the fact that this is not a GPS position, and also the ID of the exhibition facility. In this embodiment the host of the service provided by server 13 maintains, with cooperation of the host of the exhibition facility, a database relating exhibits according

- 14 -

to geographic and spatial position within the facility, and returns information to the appliance user relating to the various exhibits.

Again, dynamic position information may be used to relate to the database as well as simple position within a facility. For example, the fact of a user traversing  
5 from one room to another may elicit information pertaining to the nature of exhibits in the room being approached, while the fact of a user stopping for a predetermined time before a specific exhibit may elicit information about that specific exhibit, and so forth. In this alternative embodiment, the database for the exhibit may be maintained and updated by the host of server 13 with input from the host of the exhibit facility.

10 In an alternative embodiment server 13 may simply establish an Internet connection to an Internet-connected source maintained by the host of the exhibit, and, through cooperative software and communication protocol, the information is pulled from the exhibitors facility and pushed to the user of the appliance via the cellular Internet connection.

15 In yet another embodiment the entire information service for an indoor exhibition facility is provided at the facility, and system 73 at the facility determines not only the user's position, but pulls the information and pushes it to the user via the communication link between element 77 and system 73. In some cases element 77 in the user's appliance may be a transmitter as well as a receiver.

20 Referring now back to Fig. 2, the typical appliance in embodiments of the present invention has a speaker 51 and a microphone 49. These elements may be used with suitable software and the like to use the appliance as a cell telephone and to accomplish computer simulated telephony over the Internet, often termed IP calls. In some embodiments information pushed to a user may be rendered as speech and  
25 announced to the user, who may use earphones or an ear-piece speaker system.

Fig. 4 is a logic flow diagram illustrating a series of steps in practicing the present invention. At step 81 a user/client powers on an appliance enables according to an embodiment of the present invention. At step 83 the client selects the information service according to an embodiment of the invention. This step may not  
30 exist in some embodiments. For example, in some embodiments simply powering on

- 15 -

the appliance will select the information service. This is a dedicated embodiment. In other embodiments the service is optional, and the appliance may be used for many other functions.

At step 85 the appliance establishes connection to the service. This connection  
5 typically involves logging onto the Internet through the cell telephone service, and making the Internet connection. It will be apparent to the skilled artisan that this may be done transparently to the user, or may require user intervention.

At step 87 the appliance determines if the service is to be for an indoor or an outdoor facility. This may be as simple as the presence or absence of a GPS signal  
10 received by the appliance's GPS system. In the event the service is indoor, the appliance will receive identifying and initializing input from the local position system.

If the application is indoor, the identification will determine in step 89 whether the particular service is local position only, with Internet information, or both local position and information. For the local position and information system, control goes  
15 to step 91, and the local system determines position, and the position, and in some cases dynamic information derived from changes in position relative to time, is used to pull information and push it to the client. The process loops (95) continuing to tell position and pass information until such time as the user intervenes, or some basic parameter changes. Although this loop is shown as between steps 91 and 93, in reality  
20 the loop may be back to, for example, step 87 at least periodically, so, if the client exits the building, the system may switch to the outdoor service.

If at step 89 the determination is that the service is local position but Internet information, the appliance determines local position at step 97 (communication with local position system) and passes the position data to the Internet service, which pulls  
25 info and pushes it to the client at step 99. Again, dynamic data may be determined and used as well, as previously described, and the system continues to loop (101) re-determining position and continuing to access and push information. The loop may periodically revert at least to step 87 as well, as also previously described.

If, at step 87 it is determined that the appliance is out-of-doors, which may be  
30 determined by the access to and strength of a GPS signal, control passes to step

- 16 -

103, where the appliance determines the GPS position and passes that to the Internet service, which pulls the relevant information at step 105 and pushes it to the client. Return logic path 107 indicates that, as the client outdoors continues to move around, the system accesses different information, by position and dynamic data derived from  
5 position and change in position, and continues to push the data to the client.

It will be apparent to the skilled artisan that the flow diagram of Fig. 4 is but one rendition of steps that may depict practice of the present invention in various embodiments. The order of steps may vary in different embodiments, some steps shown in Fig. 4 may not be present in some other embodiments, and in some  
10 embodiments there may be steps not shown in Fig. 4.

#### **Intermittent Service**

In an alternative embodiment of the present invention, useful in situations  
15 where Internet access may not be readily available on a continuing basis, or may be relatively expensive, portions of a database maintained by a host of the service may be downloaded by a user/client, based on current or expected location, and stored locally accessible to the client's portable unit. In this case a user interface allows the client, while maintaining Internet access, to specify the kind of information desired and the  
20 geographic location of interest. The relevant information is then downloaded, such as, for example, information about Colonial Williamsburg or the Metropolitan Museum of art. The client, having the relevant information stored locally, such as on a flash card, floppy disk, or hard disk drive, may then operate in the specific area, accessing the locally-stored information by real-time GPS position, just as in the Internet-connected  
25 situation described above.

#### **Advertisement**

The inventor recognizes that broad practice of the present invention will create  
30 a new opportunity for commercial enterprises to advertise products and services. Such

- 17 -

advertisement in Internet models and services is at present quite well-known. Practice of the present invention, however, presents a unique opportunity for adding a previously unknown dimension to such advertisement. Now advertisement can be focused for services desirable to tourists and other travelers to just such persons, these  
5 being people enabled by the apparatus and service of the present invention, and moreover, offers of products and services to the enabled portion of the population can be made in a geographically-focused manner.

As an example of geographic focusing of advertisement, consider the traveler previously described as visiting Colonial Williamsburg, in Virginia. Such a tourist will  
10 likely have made arrangements (reservations) in advance for travel and overnight accommodations. This does not mean, however, that the person is completely satisfied with the arrangements. The actual aspect of accommodations after arrival, compared to what was advertised, is frequently one of the big surprises of a trip.

Because travelers may become dissatisfied with arrangements made in advance,  
15 there is good reason to suppose that some may be moved to change those accommodations if good information is presented. In an embodiment of the present invention, therefore, the host of the Internet-based service or of the indoor facility that pushes its own information locally to enabled clients, may arrange with hotels, motels, tour services, eateries, and the like, also indexed and selectable by geography, to  
20 provide advertisements to the enabled clients. The traveler visiting Colonial Williamsburg may be presented with availability of overnight accommodations, restaurants, and the like, in the immediate vicinity of Colonial Williamsburg.

There are a number of ways that advertisements may be focused and presented without being offensive to the travelers. For example, in one embodiment all  
25 advertisement is pushed to the traveler's portable unit, and cached in memory 41 (Fig. 2) under control of software 42. A display interface is provided (such as a selectable icon) that allows the traveler to access the advertisements as desired. It is left up to the traveler to determine the access. For example, at lunch time, or when hunger strikes, the traveler may simply access the cache and peruse a short list of local lunch  
30 establishments. Alternatively, the caching of such advertisements may be made at the

- 18 -

Internet-based service for the traveler and based on the traveler's position as reported by virtue of the GPS capability. In this case the traveler accesses the cache through Internet request rather than from the local memory of the portable unit.

The geographic filtering nature of the service of the invention creates further  
5 selectability and granularity that may be of large advantage to both travelers and  
advertisers. For example, advertisements sent to the traveler's portable device may be  
updated as the traveler moves about, so that advertisements outside of the traveler's  
instant location are not presented. In the embodiment described wherein  
advertisements are cached and the traveler is given a measure of control over the  
10 access and display, ads are removed from the cache as the traveler moves about, this  
movement reported to the service by virtue of the GPS capability.

There is still further service that may be provided for travelers. In the case of  
advertisement, the service can arrange with advertisers to keep a record of availability  
of services offered by the advertisers, such as rooms available at a bed-and breakfast.  
15 A traveler looking for a better accommodation may then make arrangement  
(reservation) through the information service of the present invention. The same  
applies to dinner and lunch reservations, tour services, who may advertise their  
schedules and availability, and so forth.

In yet another embodiment of the invention services may be provided to both  
20 travelers and advertiser clients based on the identification and location of the travelers  
using the hosted service. The service, by virtue of transmission of and return of  
*cookies* by a client, knows where the client is and, in some cases, where the client is  
going to be. Arrangements may be made with such as large exhibitors, such as in the  
example of the Metropolitan Museum of Art described above, to notify the exhibiting  
25 hosts of the presence of or pending arrival of clients of the service, such that special  
offers and arrangements may be made for the individual clients, and personal service  
may be rendered.

30



### Database Structure, Configuration and Use

The organization of the databases or databases in embodiments of the present invention is unique as are methods in accessing and dynamically restructuring the  
5 databases. For purposes of the following explanations and descriptions database (singular) is used, but it must be understood that there may be several associated databases in use at any particular time.

In the following discussion of database topics it is important to understand that the information categorized, stored, and accessed in embodiments of the invention is  
10 not limited to any one language. It is intended that end-users of any nationality and language may be enabled according to embodiments of the invention, and information may be stored in any language, translated dynamically as required, and provided in the best form according to needs of different users. In some cases this means there will be redundancy in the database, and the necessary redundancy is provided.

15 Fig. 5 is a block diagram illustrating communication between field device 29 and database 14 through a configuration interface 107 in information server 13 to database 14 in an embodiment of the present invention. Fig. 5 is intentionally general to represent a wide variety of situations within the scope of the invention. For example, a general two-way communication is represented between field unit 29 and  
20 server 13, and this communication can be implemented in any one of various ways described above, including several wireless and land-line methods and apparatus. Further, database 14 may represent data storage local to server 13 or remote but accessible, and can be implemented in a broad variety of hardware and software.

Configuration interface 107 represents the interface between incoming requests  
25 from user/clients and the associated database. In preferred embodiments Interface 107 is primarily a software suite, but may also comprise, in some embodiments, hardware elements. There are several unique aspects and features in this interface and the structure of the associated database.

The kinds of data and information assembled for users in databases 14 has been  
30 briefly explained above. Generally the assembled information is related to geography.

- 20 -

The kinds of information stored and the various dimensions of the databases is explained in more detail below:

**(A) GPS Boundaries and Regions**

5

An important dimension of the databases is position on the Earth's surface. Depending on purpose and application, the position may be relatively general, or very, very precise. For example, a position may be described as within a particular state, or alternatively (and at the same time) at a very precise coordinate on the Earth's surface.

10 To accomplish this purpose, at a relatively general level, the surface of the Earth is mapped according to GPS boundaries, as well as precise GPS position. The GPS boundaries may follow, for example, boundaries of continents, boundaries of countries, and boundaries of regions within countries and other regions, which may be somewhat arbitrary to the service itself, and so on. These boundaries define GPS regions that are  
15 identified in various ways, and the identifications are used as cross-references in the database.

The GPS regions defined as database references are in some cases very general and in others quite granular and specific. For example, the Southern Hemisphere and the Northern hemisphere of the Earth, defined by the equator, are identified each as a  
20 separate GPS region. In any query the GPS position, if any, accompanying or associated with the query, may be identified quickly as within either the Northern or the Southern hemisphere. In any case of a reported position falling on a boundary, rules apply for defining the location relative to defined GPS regions. In some such cases the position will be confined to one or the other region, and in some cases both.  
25 In still other cases the position may be determined as associated with a defined GPS region according to dynamic data of user movement, and so on.

At a slightly more detailed level GPS boundaries are defined for all continents and ocean regions, according to geography without respect to political considerations (national jurisdiction and the like). At a still more detailed level GPS regions are  
30 defined for boundaries of countries and territories according to national jurisdiction. In

- 21 -

many cases these GPS regions will define several areas. For example the contiguous states of the United States of America, and then separate areas for Alaska, Hawaii, and territories of the United States.

GPS boundaries may be established also crossing national boundaries. For example, there may be a definition for boundaries of river drainage regions of the world, which may, of course cross national boundaries, such as the drainage region of the Amazon river in South America. Another GPS boundary category of interest is economic regions, such as the European Economic Community and other such trade regions.

At a still more detailed level. GPS boundaries are defined for regions of interest in larger countries and regions. For example, the Southern States of the US, the Western states of the US, the New England areas of the US, the various provinces of Canada, the various countries in Europe, the desert regions within any country, the provinces within France, for instance, the counties in the State of Indiana in the United States, the voting districts in any democratic jurisdiction, the city limits of any major city anywhere in the world, the limits of villages below a certain population in Ireland, and so on, and so forth.

At a still more detailed level, GPS boundaries may be established and defined for sites on the surface of the Earth according to any of several information categories. As an example, organized World War II sites in Europe may be defined, such as the regions of the Battle of the Bulge, the location of cemeteries and monuments, and the like. Regions may be defined for Civil War sites in the US in much the same way, defining regions for major and minor battles, cemeteries, organized sites like Gettysburg and Andersonville and Fredericksberg and the like, as well as sites that are not formally organized.

At another level, commercial boundaries may be defined as GPS boundaries as well. In such a category locations of restaurants within easy driving distance of the center of Cincinnati, Ohio may be defined as a GPS boundary. The same might be done for men's clothing stores in upper Manhattan in New York city, and so forth.

- 22 -

At a very specific and detailed level information is stored related to specific exhibition sites, for example, and the result is specific to very small regions. The example of an indoor site, such as the Metropolitan Museum of Art in New York City was described above. In this case small regions may be defined such that the system  
5 may be able to access information about a painting, for example, related to a region of a few square feet at most, within which a person is standing to conveniently view the painting. In this case, as described above, a portable unit may report to the system a specific and relatively exact position within the museum, and the system can locate that position within a small region in front of a painting hanging on a wall of the museum.  
10 The system then "knows" to pass information to the user/client about that specific painting. The system may even know, for example, if the client is facing the painting or not, or make an educated guess, based on very recent history of the client's movement.

In the situation of an exhibition site such as a museum neutral regions may also  
15 be defined, being regions not associated with any specific display. For example, a defined region in the Met may encompass all of the floor area in a room further than six feet from any wall. The system, recognizing a user position in such a region may deliver, for example, general information about what may be found on which walls of the room within which the user is located.

20 The identification of defined GPS regions may be done in any of several ways. In one embodiment regions are assigned metadata designations, in which each defined region has a unique digital designation. A table is prepared and stored for each region in which the boundaries of the region are defined and related to the identity of the region. In processing, when a GPS position is reported or accompanies an information  
25 request in some fashion, the system may enter the table structure and quickly establish all of the defined GPS regions bounding the reported position. Then, as information is stored in the database related to defined regions, information may be easily and reliably accessed according to region. In another aspect, once the regions are defined for a request, the user's profile may also provide other information that may be used to  
30 further refine the nature of a database inquiry and response to the user's request. The

- 23 -

particular user may, for example, have requested that certain kinds of information not be sent.

**(B) The Time Database Dimension**

5

The position database dimension has been described in some detail above. Another dimension used in the database is time. Time boundaries for purposes of embodiments of the present invention are defined in a similar manner to position boundaries. For example, time boundaries may be defined for past, present and future, defining thereby three defined time regions. Time regions within the past region may be defined in a wide variety of ways; for example each past millennium, each 100 years within each millennium, each ten year period, each year, and so on down to very small time intervals in some cases. Some data may be associated in the time dimension as present, or real time. Future time may be defined in intervals similarly to the intervals for past time.

15 In some cases time intervals may be defined for subject matter. As an example, civil war data may be tagged as to the year in which certain events occurred, such as 1861, 1862, 1863, 1864 and so forth. Similar divisions may be defined for many other special categories, including wars, presidential terms, dynasties in ancient China, and so forth.

**(C) The Personal Interest Dimension**

25 Another, and very important, database dimension in embodiments of the present invention is personal interest. Interest categories are defined for database relationships according to very broad and very narrow categories. For example art may be a very broad category. Within the category of art there may be subcategories for painting, sculpture, music, literature, and so forth. Within the subcategories there may be further granularity, such as Impressionist painting, modern, surreal, and so

- 24 -

forth. Similar granularity is established within other art categories, such as classical music, hip-hop, jazz, country, big band, and so forth.

Another example of interest category is history, which may have sub categories for regional, ethnic, dynasty, monarchies, history of particular countries, history of particular cultures, and much, much more. There may be categories at broad and more detailed levels for all areas of human interest, only a very few of which are mentioned here; but the skilled artisan will recognize, given the present teaching that interest is a very broad category

10 **(D) Commercial Enterprises**

Commercial enterprises are a special database category, and information is stored, tagged and otherwise cross-referenced for many commercial enterprises, such as hotels and motels, bed-and-breakfast establishments, restaurants, bus tour services, 15 railroads, airlines, taxi services, beauty shops, barbershops, doctors and hospitals, and many, many more established businesses and government services world-wide, in every necessary language. There are many uses in embodiments of the invention at many levels for such information, as is made apparent in further descriptions below.

In some cases information about certain commercial establishments is relatively 20 limited, such as nature of goods and services, telephone numbers, and address. In other cases the relationship may extend to on-line connectability between the present service in many embodiments, and call-centers, web pages, and the like hosted by the commercial establishments made a part of the database of the present invention.

It will be apparent to the skilled artisan, given the teachings herein, that most 25 information stored in the database of the present invention will relate to more than one, and in many cases, several database dimensions. For example, detailed information about the battle of Hoover's Gap in the US state of Tennessee during the Civil War, at which battle the 17th Indiana Mounted Infantry first used repeating Spencer rifles, will be tagged as positionally in the Northern hemisphere, in North America, in the USA, in 30 the state of Tennessee, and in the county or region where the battle took place. In the

- 25 -

time dimension the time region is the past, in the 19th century, in the sixth decade, in the year it occurred, and specifically by the exact dates and times.

In the personal interest dimension for the Hoover's Gap example above the categorizations may be war, civil war, US Civil War, land battles, and so forth. There  
5 may be many more tags and cross-references for personal interest as well. Commercial enterprises associated with this battle may include present-time hotels, motels, eating establishments, and the like, which are in the region where the battle was fought.

It will be apparent to the skilled artisan, given the teachings herein, that there may be several more database dimensions utilized within the scope of the invention.

10 There are a variety of ways information in the database may be tagged or otherwise cross referenced in line with the dimensions described, and other dimensions. For example, information may be grouped in most instances according to some close relationship. For example, all information about Colonial Williamsburg may be grouped by the particular fact of being about Colonial Williamsburg. regardless of  
15 physical grouping, this information will be tagged as history, US history, colonial history, and so forth in the area of personal interest. The information will be further tagged according to particular periods in US history.

For this example of Colonial Williamsburg specific site information will be tagged according to position on-site, and according to defined regions within the  
20 bounds of Colonial Williamsburg. A GPS position within the defined bounds of this site will be recognized as such for purposes of accessing information, and within the region, detailed information about specific sites is related more closely to exact position.

There are a variety of ways data tagging may be done. Typically data elements  
25 in the database structure will be tagged by a digital word of suitable length, different bits at different significance positions providing the dimensional information. In a 64-bit word, for example, 16 bits may be reserved for positional specification, 16 bits for time specification, 16 bits for interest, and 16 more bits for other classification. There are many methods known in the art for data tagging.

30

- 26 -

**Accessing the Database and Examples of Services Provided**

Referring again to Fig. 5, requests of many sorts may come to server 13 from enabled appliances from anywhere on Earth, and in literally any language. Device 29 in Fig. 5 is meant to represent any appliance that may be able to access the on-line service, such as a desktop computer, a laptop computer, another web site, a cell telephone, a caller to a call-center via a conventional telephony service, or via an enabled WAP or cellular-enabled device having also GPS capability as described above. In examples below, methods of accessing and sorting are described by specific examples of defined services in embodiments of the invention.

**Continuous on-site access and delivery** - In one example above, in a preferred embodiment, a traveler/client has a hand-held device enabled to access the Internet in a wireless manner, and also to track its own position via an integrated GPS system. A traveler with such a device may at any point in time initialize the device and access the services in embodiments of the present invention generally represented by server 13 in this specification.

In this situation the device may be a completely dedicated device, so when it is powered on, contact with server 13 is established automatically and transparently, and maintained until intentionally terminated by the client. In other cases the device may have multiple uses, and a client may be required to select the service of embodiments of the present invention through a convenient user interface, such as a graphic interface displayed. The means and protocol of access is not particularly material to the invention.

In this example, in the initial contact with the Internet-enabled service of the invention, the service typically identifies the client and sends a cookie, which is lodged at the client device in a cookie file. This process is known in the art, and may require the user to fill out a log-in form with such as a user-name and a password pair, which may be a remembered pair automatically entered in the form by the user's device. In other embodiments the log-in and confirmation may be done transparently to the user



- 27 -

of the client device. In some instances authentication is not particularly critical, because no secure or sensitive information is downloaded in the process. In others higher levels of security are required. Typically, after initialization and until the client intentionally terminates, the filed cookie is used in further communication to maintain authentication and client identity with the service.

**Device as Client** - Further to the above, there are embodiments of the invention wherein the device itself is the client, rather than a particular person who is the owner and operator of the device, and this situation is covered below firstly. This situation attains, for example, at highly organized exhibit sites. Such sites are, for example, the Metropolitan Museum of Art in New York City and Colonial Williamsburg in Virginia, used in previous examples, or, as a new example, the San Francisco Zoo. At such sites, through cooperation between the services of the present invention and the host of each site, client devices may be provided for use by visitors. There are many possibilities in how such devices may be provided and maintained, accounted for, and so forth, and how the users visiting such sites may pay for the service, if at all.

In this situation, a visitor registers at the exhibit site and is provided with a working client device. For purposes of description assume the device renders downloaded information to the visitor by audio through a single earphone. Fig. 6a is a flow diagram depicting communication between the Internet service in this embodiment of the invention and the client device expanding on the loop of steps 103, 105, and 107 of Fig. 4, and including database access interface 107 shown in Fig. 5.

In this diagram the client side is depicted as a vertical line on the left of the diagram, and the server side by a vertical line on the right side. Communication is shown by arrows between the two sides, manipulations wholly accomplished on one side are shown on that side, and time is on vertical scale, advancing top down.

After initialization, at step 1, a log-in request goes from the device to the server. The server recognizes the client unit, and opens a session for the client unit at the exhibit. This session is software managed at server 13 (Fig. 5), and may be one of a very large number of sessions being managed for different devices and clients.

- 28 -

Once the client unit is identified and a session is opened, the service acknowledges the log-in. At step 3 a data request is sent by the client device. There are a number of protocols under which data requests may be made. In one protocol, data requests are made at pre-programmed time intervals, such as every ten seconds.

5 In an alternative protocol no data request goes to the server unless a user of the client device initiates the request. There may be other protocols, and there may also be an interface under which a user may switch from one protocol to another.

In any case, when a data request goes to the server (step 3) that request is accompanied by a precise location for the device. In outdoor sites this position may be the result of GPS coordination, or determined by a local position system. In indoor sites the position will typically be determined by a local system as described above.

In this example, in response to the request at step (3) the server accesses exhibit information according to position (location) and sends appropriate information. Typically, in this situation, where the device is the client, provided at a site for temporary use by a user, there is no server-stored user profile which may be used for further filtering of requests. However, the information accessed and sent may be selected by more dimensions than just the instantaneous position. The device's (user's) movement may be used as well, and the rate and direction of movement, or recent history of movement.

20 After the service determines the information to be sent, that information goes to the client device (step 4). At step (5) another data request is sent by the device to the server, and the server, in response, updates the dynamic location and history data for the session, and stores the necessary data for the session. At any point in time, then, the system knows the precise location of the client device, the previous locations, providing a track record including direction and rate, and can make future predictions as well, based on past movement. There may be included an interface for a client to, for example, retrace the history of a session, and so on.

At step (6) the server has again accessed appropriate information about an exhibit and sent that information along to the client device. When a user is finished with a tour and turns in the temporary client device, a worker at the site may cause a

30

- 29 -

document to be printed describing the user's tour, as a souvenir. This document may include boilerplate elements about specific exhibits, which may be organized and presented according to the session history.

Once the tour is finished, and any peripheral services, such as the souvenir document, is provided, the device is turned off, or a signal is sent terminating the session. The server software 107 may archive some information (# of visitor, length of tour, etc., for statistical purposes, for example). Then the session is erased. A new session will be initiated the next time the specific device is activated with a new user.

10 **User as Client** - In other embodiments the device, the Internet appliance that is used to access the server and download information, is owned by, or at least registered to a specific user. In these embodiments the user will typically be a subscriber to the service, and, in the process of subscribing, the user will have entered a considerable amount of information. At a minimum the service will have the user's address, name, 15 and such identity information. At another level, according to user preference, the user may supply considerable additional information, including data about age, gender, education, occupation, specific areas of interest, and so on, perhaps prioritized. There will be levels of service that can be provided to users who are willing to subscribe to the higher levels and to provide the kinds of user-profile information that will be 20 required to provide the higher levels of service. Further services may require such as credit card information, deposit accounts, ability to access accounts for payment for services, and so on.

In any case, subscribers will have each a user profile to some depth, determined by the subscriber. In addition to the raw profile, a data record is kept for each 25 subscriber, storing many kinds of information, including a history of on-line sessions, types of sessions, tours planned and taken, purchase history, and so forth. All of the archived information for a subscriber is cross-referenced and may be accessed by the subscriber for many purposes, and by the service for other purposes, with permission of the subscriber. Many of these additional services and abilities are described in 30 further detail below.

- 30 -

In the case of a user-related device, where a user is a subscriber and a user profile is kept, the range of services is much broader than described above for temporarily-assigned devices. In this example continuous, or frequent intermittent access is still the norm, just as described above for the temporarily-assigned devices.

5 In this example, assume the subscriber client initiates the device at any particular geographic point, which may any precise position on the surface of the Earth. Fig. 6b is a time diagram similar to that of Fig. 6a illustrating information access and provision in this case, where the client is the subscriber (person).

When the subscriber powers on the device (dedicated device) or signals for  
10 access to the service, such as by asserting a URL for server 13 (multi-purpose device), a log-in request goes to server 13 at step (1). In this case rather than an automatic log-in wherein the server recognizes the Internet appliance, as above, the server will identify the client/user/subscriber. This is done in a preferred embodiment by the server sending back a log-in form at step (2). At step (3) the subscriber has populated  
15 the form and sends it back to the server. This may be done by entering data in the form fields, or in some cases, the form-filling may be automatic, and even transparent to the client.

In response to the filled-in form, the Server Software verifies the client (user) and opens a session for client. The Server also accesses a client profile, if available,  
20 and client history. The Server then acknowledges verification to the user device in step (4). The client is now involved in an active session with the service, and may send information requests. As previously described in the case for the unit as client, the information requests may be automatic, timed requests, say one every two minutes, or the system may wait for the client to initiate a request, such as through a graphic user  
25 interface, or there may be some combination.

In any case, at step (5) an information request goes to the service, accompanied by a precise location, which may come from GPS in outdoor locations, and from a local positioning system in many indoor locations, as previously described. The server now may respond in a number of different ways, depending on circumstances. Server  
30 Software uses the precise position to identify all defined regions occupied, including

- 31 -

whether the unit is in an exhibit region, such as a zoo or museum. The service then consults client profile data and retrieves and sends to client the appropriate information based on all applicable database dimensions (Step 6).

There are a broad variety of possibilities. For example, the user may be  
5 identified as being within an exhibit site, such as the Met as in previous examples above. The server may in this case behave and respond to information requests just as described above for the case of temporarily assigned devices. In some cases, the subscriber may have a special relationship with the exhibit, such as being a lifetime  
10 donor for a zoo, and this information may be a part of the user profile. In such cases there may be special services provided by the service, often in cooperation with the enterprise hosting the exhibit.

As another example, according to position returned with an information  
request, the client may not be in a specially choreographed site, but at-large. Geographically roaming might be an apt description. In this case the service may,  
15 through access to the client profile, determine that the client is especially interested in this session in U.S. Civil War information, and may return information about sites and exhibits of interest within a pre-defined range of the client position, or within a defined region.

In another example, developed more fully below, the client profile may indicate  
20 a client pre-planned itinerary, and return information according to different interest dimensions according to location, including defined regions associated with the location.

At step (7) the client's device sends another information request, either  
automatic or user-initiated. The server in response updates dynamic location and other  
25 statistical and historic data, and stores necessary data. This action is continuing in a session to develop and store a complete record of user locations, static and dynamic, and all user activities. The Server Software also accesses information in database according to all pertinent dimensions and profiles, and sends appropriate information in step (8).

- 32 -

The process continues throughout a client session, with more requests to the server, and more data accesses and deliveries to the client.

### **Fixed Access Uses of System**

5

The unique structure of database 14 (Fig. 5), wherein information about a broad variety of subjects is cross-referenced in several dimensions, such as geographic position in defined regions and precise locations, by time, and also by information type relative to client interest categories, is described in some detail above.

10 This unique cross-referencing and ability to access information by these dimensions provides an opportunity for a range of unique services that do not require use of and interaction with a portable device.

In another aspect of the invention the system of the invention may be used for a variety of unique services not involving a particularly portable client device, or real-  
15 time knowledge or input of the client's geographic position. In this aspect Fig. 7 is a diagram depicting access to server 13 by a client using a desktop PC, such as the client may have in a home or business.

**Tour Planning** - One unique use of the system is in tour planning by subscribers. A  
20 subscriber using a desktop computer 109 (for example), connecting to server 13 through an ISP 111 (for example), is provided with a unique service for planning tours and trip itineraries. In one embodiment the subscriber, logging on to server 13, after log-in and authentication, is presented with a Graphical User Interface (GUI) having hyperlinks for various available service, one of which is for trip planning. By selecting  
25 this hyperlink the subscriber is presented with a new GUI with a range of parameter fields for planning a trip.

Fig. 8 is an exemplary interface 113 for trip planning in an embodiment of the invention. Title 115 identifies the interface, and there are three input fields in this simple example, field 117 for selecting an interest category, field 121 for defining a

- 33 -

region for the trip, and field 123 for selecting a time window. A help link 125 links the subscriber to help functions if needed.

In field 117 the subscriber provides input for an interest to define the trip. Interest categories were defined to some extent above. For example, interests may be  
5 such as sculpture, music, American history, the Gulf War, rare books, antique collections, beat poetry, and so forth. A constraint is that interests to be input must be interest dimensions defined for the database, or the database cannot function according to the dimension.

In a preferred embodiment server 13 is enabled to deal with natural language  
10 input, so a subscriber may type in, for example, "Civil War", or "War of Rebellion", or "War between North and South", or some other natural language input. The system has a parser function for selecting significant nouns, and using these to determine most probable defined interest. In some cases in this mode, the server may come back with a pop-up query to further define the interest. For example, the user may input "War  
15 between North and South", and the system may come back with "U.S. Civil War? (Yes) (No). To which the subscriber is expected to respond.

In this manner the system may take typed input and arrive at a defined interest dimension. There may also be further interrogatories, such as defining time ranges for interest. A person interested in the U.S. Civil War may be interested only in one  
20 particular year of the Civil War.

Alternatively to the above, the subscriber may use a drop-down menu activated by arrow 119, in which case a menu of interest dimensions will be displayed, and the user may point-and-click, or scroll to highlight and select, techniques that are well-known in the art. In this facility, because there are numerous interest dimensions  
25 defined in the system, dimensions may be presented first by category, such as Art, war, and so forth, and upon one of the higher level categories being selected, a new drop-down list providing further definition is displayed. Again, when a defined interest dimension is finally selected, additional information may be solicited.

In field 121 the subscriber selects a region for the trip. Again, natural language  
30 input can be used, or the subscriber may use the drop-down menu method, and the

- 34 -

system may respond with interrogatories to refine the selection. For example, the subscriber may have selected Modern Art as an interest, and now defines Spain as a region. One further dimension is sometimes required for the system to perform the unique trip-planning function. This is a time window selectable via field 123. The time  
5 window is a range in time when the subscriber wishes to make the trip. This, of course, will always be a future window. The same kinds of input characteristics as described above are operable for field 123.

One reason the time dimension is needed is that for many interest categories, certain exhibits displays, auctions, and the like may or may not be available at certain  
10 times. The database is maintained on a continuing basis with new information. For example, given one particular month in a coming year, the data base may list one matrix of displays and exhibits for modern art in Spain, and for another month, the matrix may be somewhat, or even radically different. On the other hand, for some interest categories the time window may be irrelevant. A subscriber may, for example,  
15 have selected Spanish villages in the Basque region as an interest, and the villages will be the same over very long periods of time.

Once the input is made, the server software loosely indicated by element 107 in Fig. 7 queries the database, applies pre-programmed rules, and builds one or more itineraries of interest for consideration by the subscriber. Staying with the present  
20 example of Modern Art, Spain, and assuming a time window of the last two weeks in July of the year 2000, the server software enters the database, determines all of the Modern Art exhibits and displays in Spain, which are tagged by location and defined sub-regions (see above for defined GPS regions) for the time window, and builds one or more itineraries for a proposed trip/tour.

25 In building the candidate tour(s) the system may apply a number of rules. One such rule has to do with location of major airports and/or ports of entry. This rule is applied if the subscriber profile indicates the subscriber is likely to begin such a trip from, say, the U.S. or Japan. Beginning with a major airport, for example, the system will find exhibits in the interest dimension within easy access distance of this potential  
30 arrival point. The system will apply a time relative to the total time window for



- 35 -

visiting these close sites, say two days for the number of sites selected, then the system will range to another region near the arrival point, and do the same. In this manner one or more candidate itineraries are built around the input dimensions.

The next step is for the system to present the candidate itineraries to the  
5 subscriber, which may be done in several ways. The subscriber may be presented with, for example, a sequential list of places (cities and towns, for example), the stopover times, and a list of all of the exhibits to be visited at each stopover. There may also be, for example, a map showing the same information, to make the itinerary more graphic. The subscriber is now given an interface for selecting one of the candidates, and then is  
10 also allowed to make alterations. The subscriber may, for example, through a GUI and input field interface, delete exhibits, delete stopovers, re-arrange the order of stopovers, and so forth, until satisfaction is struck.

**Tour implementation** - Once a tour is planned, it remains to implement the tour, if  
15 the subscriber intends to make the trip.

By implementation is meant actually buying the airline tickets into and out of the point of arrival in Spain, say Madrid, for the example Modern Art tour. Also all of the overnight accommodations necessary and travel between stopover locations on the tour; all of the details of actually making the tour. For this purpose a number of  
20 facilities are provided. A subscriber may, for example, jump from the display provided by server 13 to the home page of a major airline, where reservations may be made and paid for, and may locate and jump to local travel services and overnight accommodations in all of the various places on the tour, and accomplish thereby, all on-line, all of the implementing details for the tour.

25 Alternatively, a referral service is provided, whereby the subscriber may be transferred to a travel service which will offer experienced input to aid the subscriber in making all of the necessary accommodations. The travel service, cooperating with the service of the present invention, is then provided with a copy of the itinerary for the subscriber, and the travel service then performs the necessary functions. In the final

- 36 -

implementation it will be understood that further alterations (hopefully minor) may still be made in the scope and progression of the planned tour.

**Virtual Tours** - In an alternative embodiment of the invention a subscriber may define  
5 a tour around specific interest, regions, and time frames as above, then request from  
the service a virtual tour. The multi-dimensional database, for this embodiment, stores,  
or has access to multimedia files relating to the defined tour. For example all, or a  
portion of, pictures in museums of modern art in the various defined stopover points  
are accessible as high-resolution picture files. General interest pictures and sound files,  
10 or even video clips, may be available for the regions where the exhibits, museums and  
the like are located. In this way a fully graphic virtual tour is created, and presented to  
the subscriber. The tour, once created may, for example, be downloaded to the  
subscriber, provided on a CD-ROM, streamed in real time, or a combination of  
delivery means.

15

**Professional Tour Creation**- In another embodiment of the invention, subscribers  
may be referred directly to professional tour planners, who intervene on the  
subscriber's behalf to use the services provided in embodiments of the present  
invention to create tours for the clients, and then verify and implement the tours. In  
20 some embodiments the professional tour planners are agents of the enterprise hosting  
the services of embodiments of the present invention, that is, the host of server 13.

In still another embodiment of the present invention a service is provided to  
professional travel planners and agents for creating group tours around interest  
dimensions, just as an individual subscriber creates an individual tour in the example  
25 above. In this embodiment the professional agent may create tours, verify the tours for  
pre-panned numbers of travelers, then advertise and fill the tours. In some cases the  
advertisement and filling of tours may be done through facilities of server 13 as well.

**Variations** - In one variation of the above tour planning and implementation a  
30 subscriber may plan a tour, then download all of the pertinent information for use in

- 37 -

storage with a portable device, such as a hand-held computer or a laptop computer. Then when the tour is actually taken, the subscriber person may, at each stopover, use the information stored to provide guidance and supplemental information on the tour. This variation has an advantage that the times and stopovers may be changed  
5 considerably, and the information is still useful, because it does not necessarily have to be accessed in the order of the original tour stopovers. Also, the information may be displayed on the computerized device, or may be printed out and carried along, or may be rendered as speech, for example, as needed and wanted. In still another variation the subscriber may implement the tour and save it in the subscriber's own profile  
10 information at the server. Then, when the subscriber makes the tour, he/she may access the service with a GPS-enabled hand-held device, as described in detail above, and receive real-time guidance according to position while in the field on the tour.

#### Additional Services and Applications

15

The combination of a multi-dimensional database wherein many types of information is cross-related by location, time, and interest categories, with or without a position-reporting appliance, affords opportunities for a wide variety of unique services beyond the services described in embodiments of the invention above. Several such  
20 applications in alternative embodiments of the invention are described below:

#### Corporate Applications

There are many services afforded for corporate and other enterprise and  
25 organization users of the GlobalRover system. For example, employees of an enterprise may be provided with portable, position-reporting units, and the enterprise may maintain an online database and cooperating software for use by the employees. The employees may then be provided with corporate information according to time and location as they move about among many enterprise locations. The areal extent  
30 will of course vary from enterprise to enterprise. One corporation may be a multi-

- 38 -

national business with locations all over the globe. In this case, information may be referenced by defined regions, which are defined by corporate facilities in different countries.

Other enterprises may have a single location, and information may then be organized by defined regions within the location. Within one building, for example, an electrical maintenance worker may be provided with electrical diagrams and schematics pertinent to a building according to his/her location in the building. Workers checking underground pipelines and cables may be provided with charts of the underground facilities in the immediate vicinity of the worker's location just as though the portable device might be a radar machine seeing under the surface. In this case the diagram might change as the worker moves, according to the direction and speed of movement. The kinds of information that may be presented dynamically by location, extrapolating from the examples just given, are truly very large.

In still other embodiments it will not be necessary that a worker or employee of an enterprise have a location-reporting appliance, in the sense that the appliance automatically reports location to the remote database. A network-connected appliance without, for example a GPS system or another position pinpointing system may be used by a person to enter location; either the actual location or another location of interest, and the system will then transmit the information associated with the location.

20

#### Locating Users Through Devices

In another embodiment, because the system has user profiles, and users carry portable devices that report position, the system may be configured in some embodiments to report locations of registered persons. Such an application may be used by, for example, by a delivery service to track locations of delivery trucks/drivers. A supervisor may then make decisions based upon mapped employee location. This or a similar application is useful for all sorts of fleet enterprises, delivery services, rental car agencies, postal services, and many more. In applications wherein children have a location-reporting device, the system can locate missing or lost children

30

- 39 -

In the case of children, as mentioned above, the unit need not be a two-way device like the appliances described above. A device according to the invention may be simply a box having GPS and an Internet connection reporting position to the remote system (server 13). An authorized person (parent, police worker) may access  
5 the system and find the location of any registered user that has an operating device.

The skilled artisan will recognize that there are a variety of alterations that may be made in the embodiments of the invention thus far described, without departing from the spirit and scope of the invention. For example, the nature of the appliance used may vary, with the requirement that there be a position determining system upon  
10 which selection of information may be predicated. There may be for example one of either a local position determination system (indoor application) or a GPS system; or both may be present. In the selection of information to be provided to a client, simple position may be used, or position data derived from simple position reported over time may be used, or both.

15 Because Internet access is not uniformly available in all regions of the planet, ability to download chunks of information to a portable device is important in various aspects of the invention. The information may be refreshed an upgraded at periodic intervals that access is available, such as kiosks in various places.

In some embodiments there may be an interface for a user to interface with the  
20 service, as exemplified at the appliance. Information may thus be cached, rather than delivered to the client in a steady stream, and the client can control the presentation, and the mode of presentation. There are many such alternatives within the spirit and scope of the invention, and the scope of the invention is therefor defined by the claims that follow.

- 40 -

What is claimed is:

1. A multi-dimensional information repository, comprising:
  - a plurality of stored data structures;
  - 5 one or more tags associated with individual ones of the plurality of data structures; and
  - a data retrieval system;
  - characterized in that data structures are tagged according to locations and defined regions relative to the surface of the Earth, and the retrieval system retrieves
  - 10 information from the data structures according to location data accompanying requests for data.
  
2. The repository of claim 1 wherein individual ones of the plurality of data structures are tagged according to time in addition to location and defined regions, and both tags
- 15 are used in retrieving data structures.
  
3. The repository of claim 1 wherein individual ones of the plurality of data structures are tagged according to human interest categories in addition to locations and defined regions.
- 20
  
4. An Internet-connected subscription server system, comprising:
  - a data repository having data structures tagged according to locations and defined regions relative to the surface of the Earth;
  - a communication module for receiving data requests accompanied by location
  - 25 data; and
  - a code set for managing retrieval of information from the data repository in response to the data requests;
  - characterized in that the system, receiving a data request, uses the location data accompanying the request to determine location in individual ones of pre-defined
  - 30 regions, and uses the pre-defined region information to access data structures and

- 41 -

retrieve information related to the pre-defined regions for transmission in response to the data requests.

5. The system of claim 4 wherein data structures are tagged according to time data in addition to location, data requests include time data, and the system accesses data structures in part according to the time data.

6. The system of claim 4 wherein the system maintains subscriber information profiles, including subscriber interests, data requests identify individual subscribers, data structures are tagged according to interest categories, and the system accesses data structures in part according to the stored interests of the subscriber initiating a data request.

7. The system of claim 4 wherein the data repository is a first data repository local to the Internet server, and wherein the system, through the code set, accesses remote Internet-connected information sources, and retrieves information from said remote sources according to one or more of stored client interests and the location data accompanying the client's request.

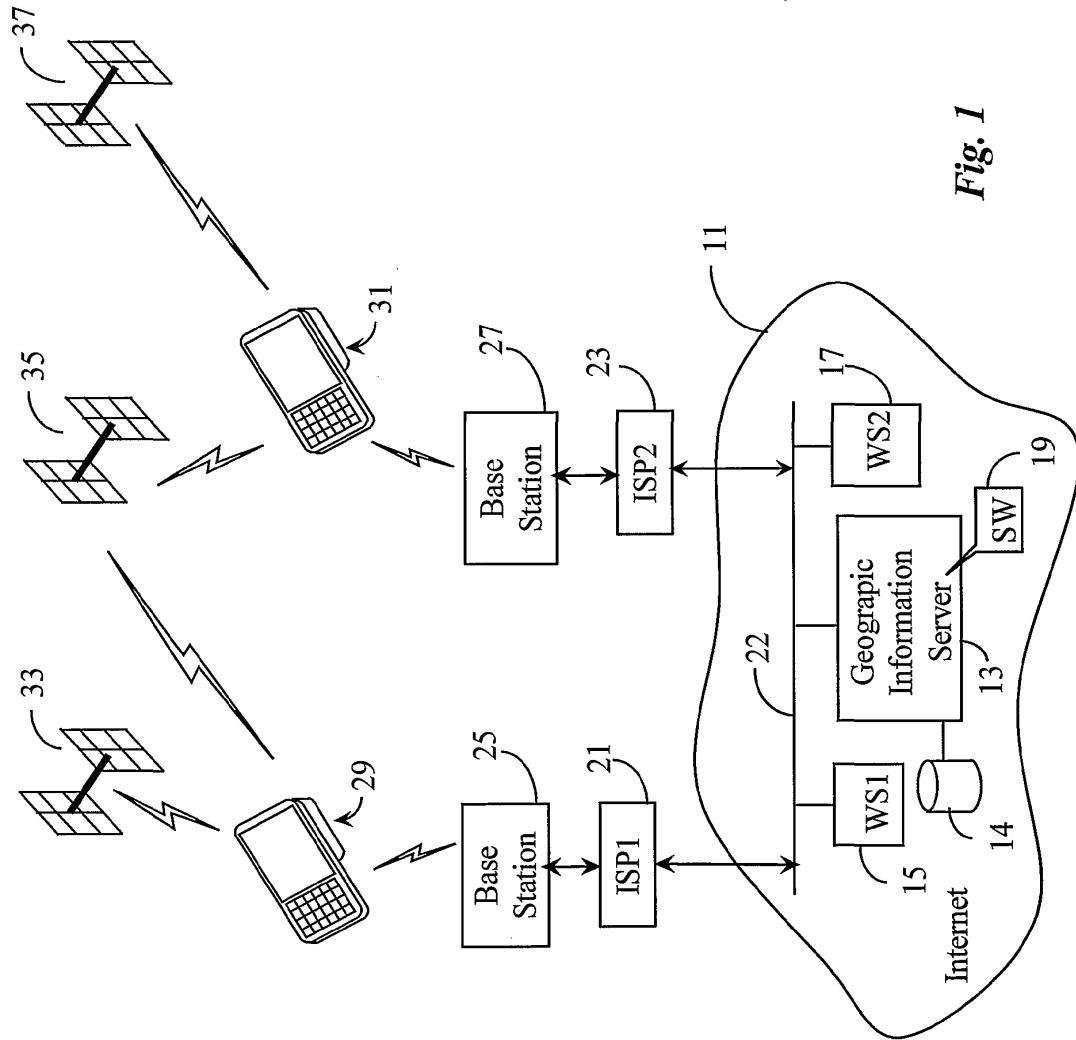


Fig. 1



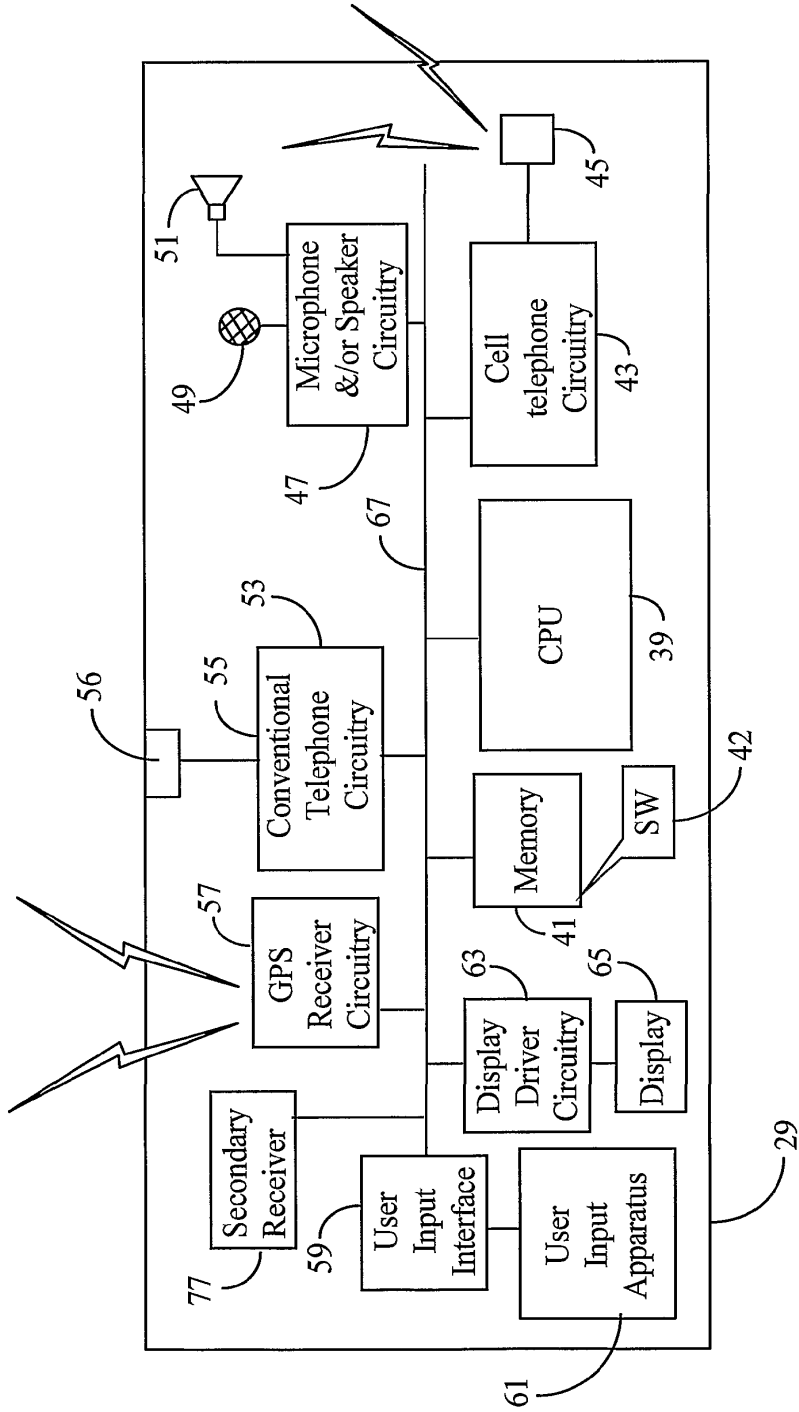


Fig. 2

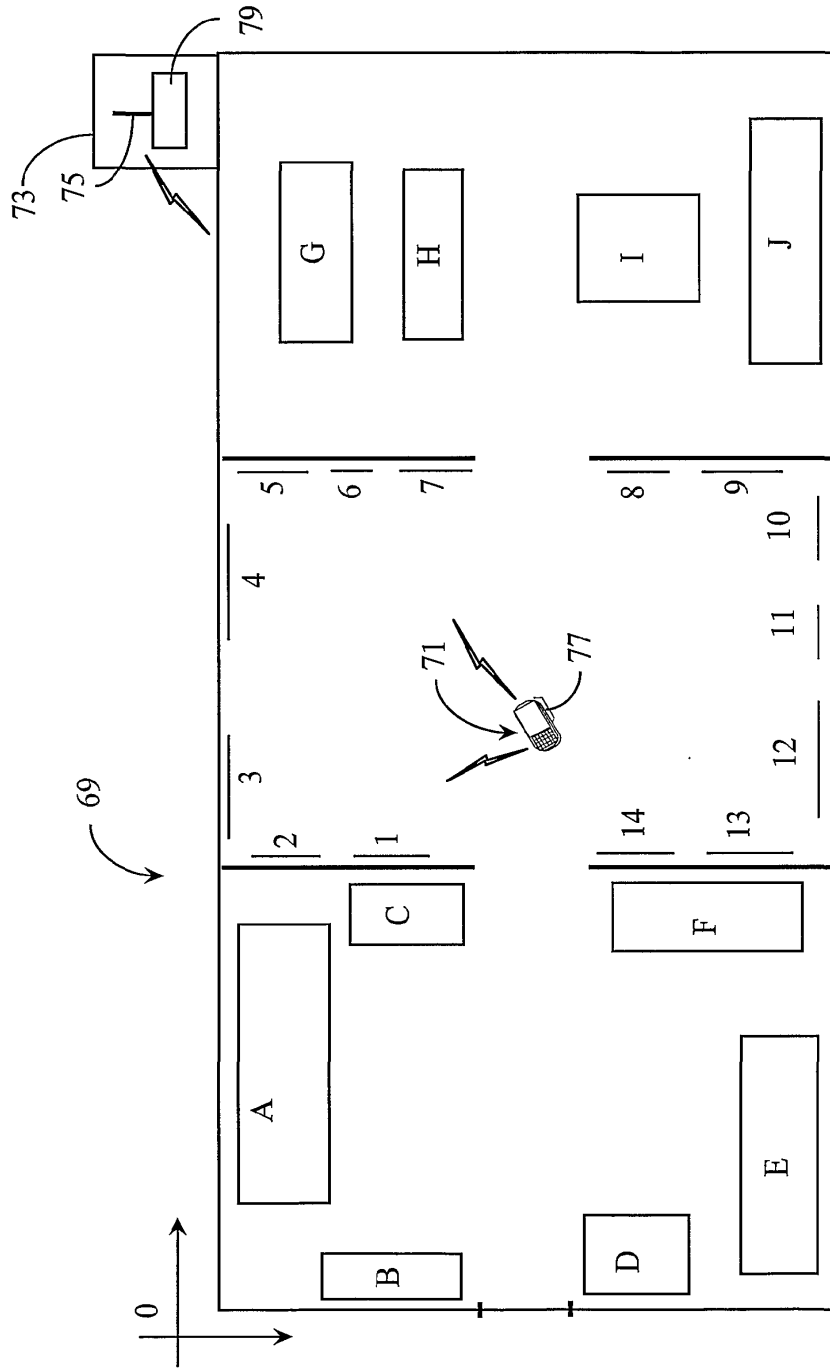


Fig. 3

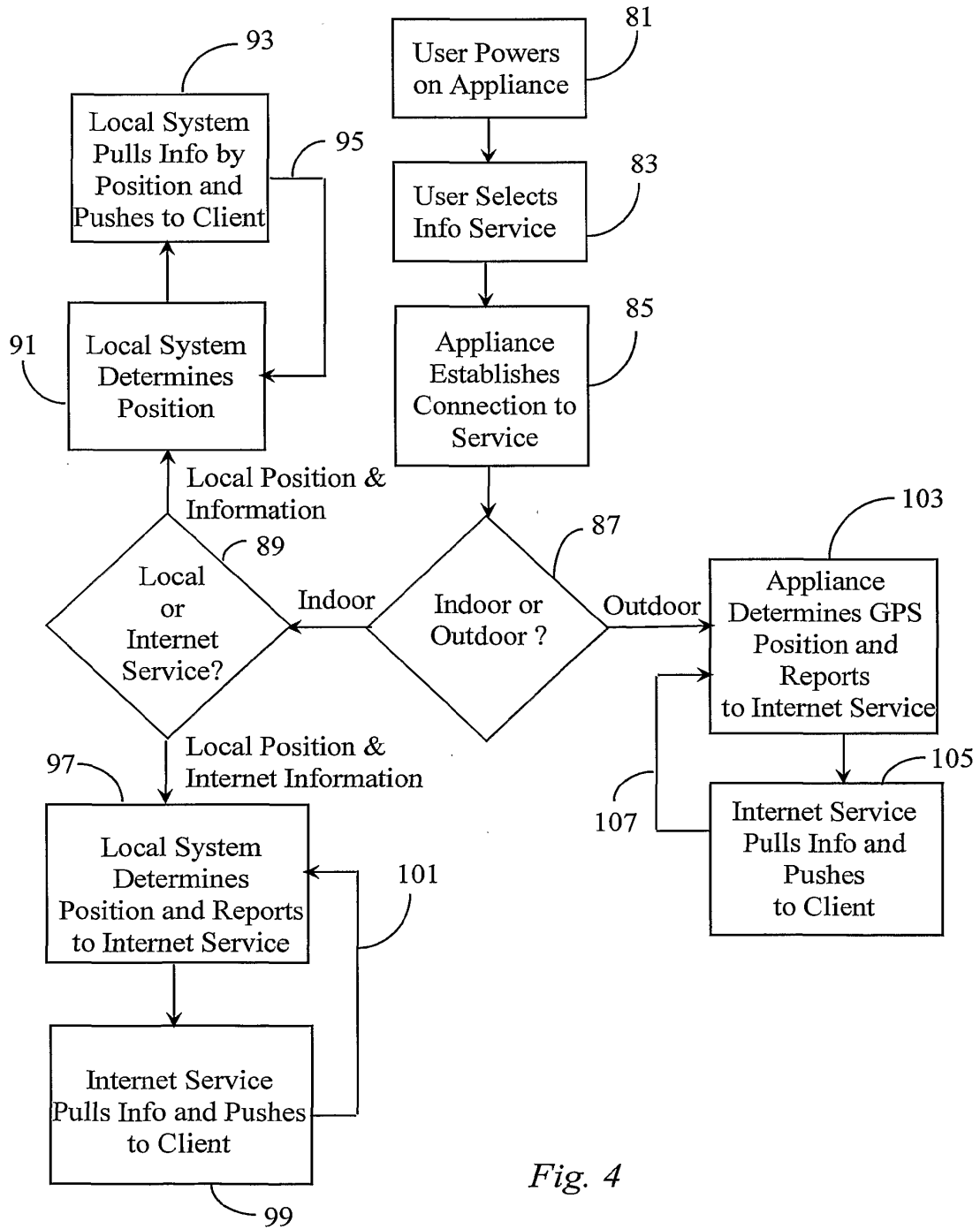
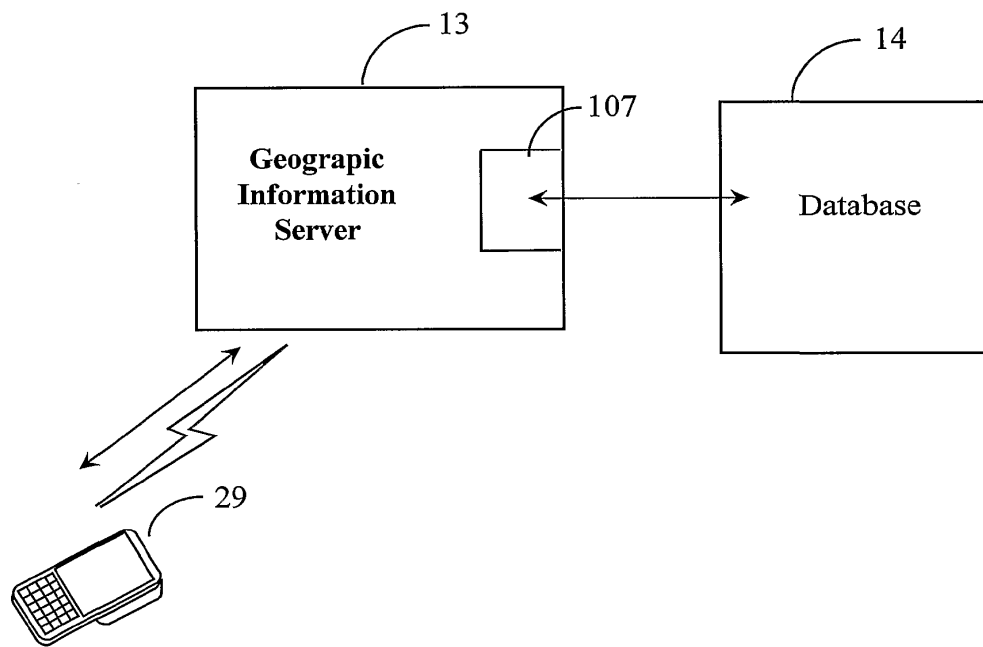
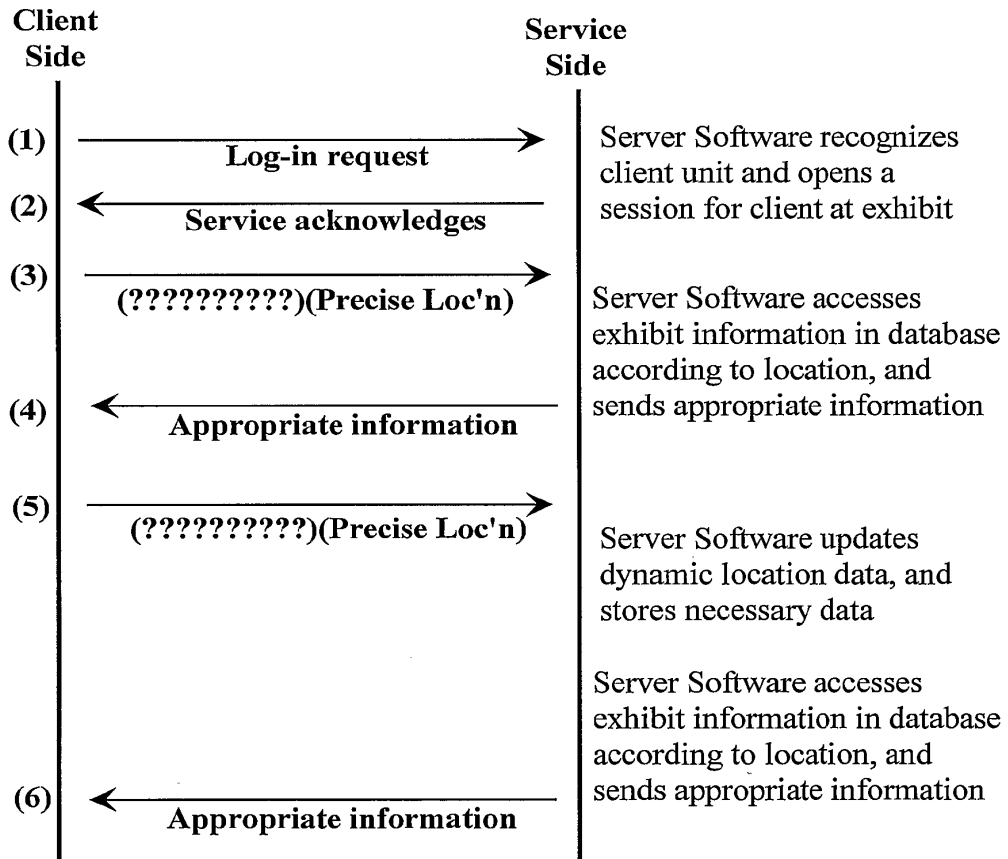


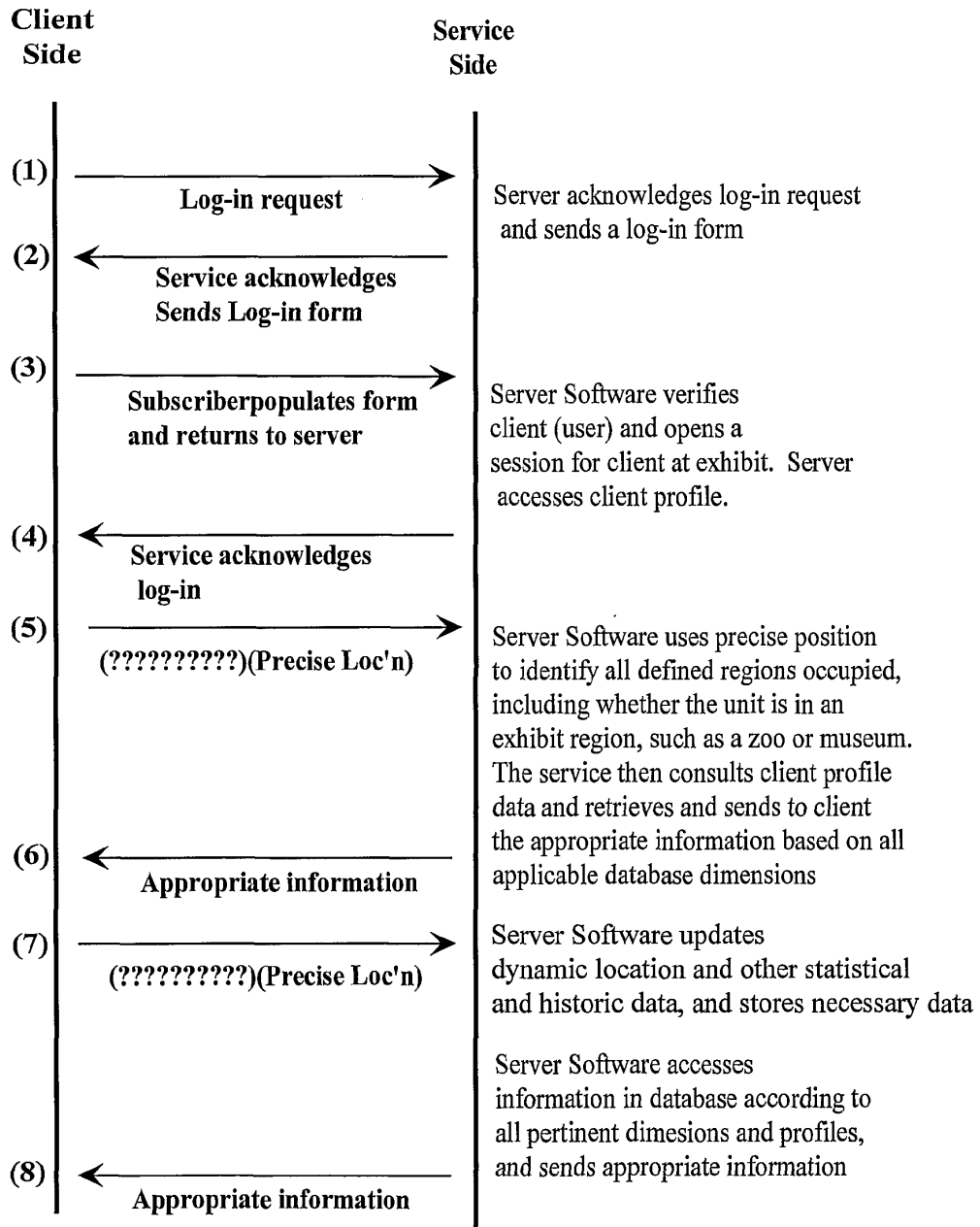
Fig. 4



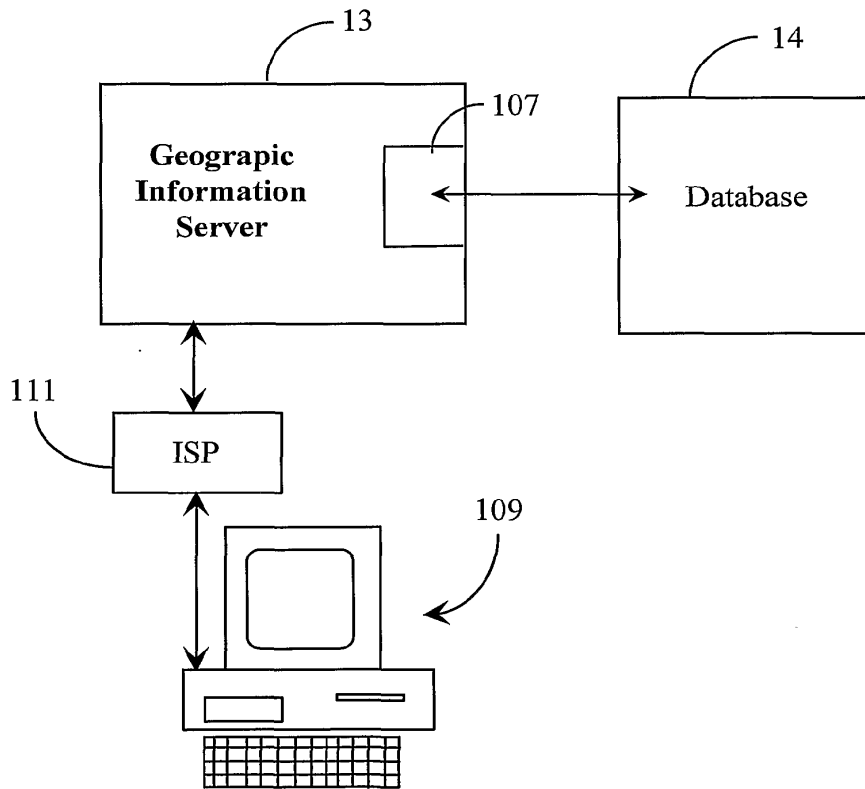
*Fig. 5*



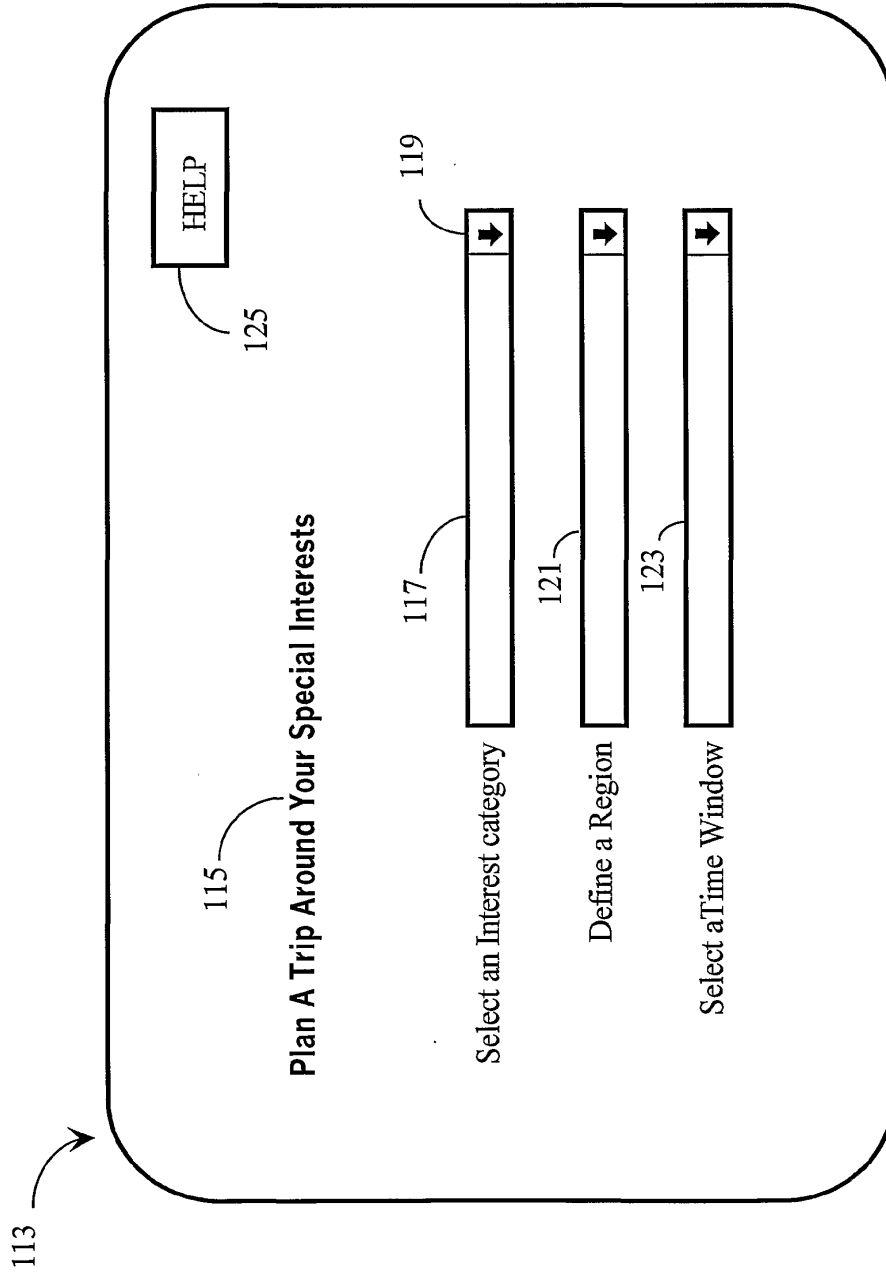
*Fig. 6a*



**Fig. 6b**



*Fig. 7*



**Fig. 8**



INTERNATIONAL SEARCH REPORT

International application No.  
PCT/US00/35250

| <b>A. CLASSIFICATION OF SUBJECT MATTER</b><br>IPC(7) :G06F 15/16; G08B 5/22<br>US CL :709/217, 218, 229; 340/825.49<br>According to International Patent Classification (IPC) or to both national classification and IPC  |  |  |
|---|--|--|
| <b>B. FIELDS SEARCHED</b><br>Minimum documentation searched (classification system followed by classification symbols)<br>U.S. : 709/217, 218, 229; 340/825.49<br>Documentation searched other than minimum documentation to the extent that such documents are included in the fields searched<br>Electronic data base consulted during the international search (name of data base and, where practicable, search terms used)<br>STN<br>search terms: GPS, subscrib, time position, wireless, Internet  |  |  |
| <b>C. DOCUMENTS CONSIDERED TO BE RELEVANT</b>   |  |  |
| Category*   | Citation of document, with indication, where appropriate, of the relevant passages | Relevant to claim No.  |
| X   | US 5,959,577 A (FAN et al.) 28 September 1999, see entire document.                | 1-7  |
| X,P   | US 6,047,327 A (TSO et al.) 04 April 2000, see entire document.                    | 1-7  |
| A   | US 5,638,077 A (MARTIN) 10 June 1997, col. 5, line 30 - col. 8, line 61.           | 1-7  |
| A   | US 6,087,983 A (HO et al.) 11 July 2000, col. 5, line 35 - col. 6, line 52.        | 1-7  |
| <input type="checkbox"/> Further documents are listed in the continuation of Box C. <input type="checkbox"/> See patent family annex.   |  |  |
| * Special categories of cited documents:<br>*A* document defining the general state of the art which is not considered to be of particular relevance<br>*E* earlier document published on or after the international filing date<br>*L* document which may throw doubts on priority claim(s) or which is cited to establish the publication date of another citation or other special reason (as specified)<br>*O* document referring to an oral disclosure, use, exhibition or other means<br>*P* document published prior to the international filing date but later than the priority date claimed |  | *T* later document published after the international filing date or priority date and not in conflict with the application but cited to understand the principle or theory underlying the invention<br>*X* document of particular relevance; the claimed invention cannot be considered novel or cannot be considered to involve an inventive step when the document is taken alone<br>*Y* document of particular relevance; the claimed invention cannot be considered to involve an inventive step when the document is combined with one or more other such documents, such combination being obvious to a person skilled in the art<br>*&* document member of the same patent family |
| Date of the actual completion of the international search<br>25 FEBRUARY 2001   |  | Date of mailing of the international search report<br>04 APR 2001  |
| Name and mailing address of the ISA/US<br>Commissioner of Patents and Trademarks<br>Box PCT<br>Washington, D.C. 20231<br>Facsimile No. (703) 305-3230   |  | Authorized officer <i>Perrot Hand</i><br>MARK RINEHART<br>Telephone No. (703) 305-3800   |

(12) INTERNATIONAL APPLICATION PUBLISHED UNDER THE PATENT COOPERATION TREATY (PCT)

(19) World Intellectual Property Organization  
International Bureau



(43) International Publication Date  
17 January 2002 (17.01.2002)

PCT

(10) International Publication Number  
**WO 02/05486 A2**

- (51) International Patent Classification<sup>7</sup>: **H04L 12/00** (74) Agents: **ROBERTS, Jon, L.** et al.; Roberts Abokhair & Mardula, LLC, Suite 1000, 11800 Sunrise Valley Drive, Reston, VA 20191 (US).
- (21) International Application Number: PCT/US01/21540
- (22) International Filing Date: 6 July 2001 (06.07.2001) (81) Designated States (*national*): AE, AG, AL, AM, AT, AU, AZ, BA, BB, BG, BR, BY, BZ, CA, CH, CN, CO, CR, CU, CZ, DE, DK, DM, DZ, EC, EE, ES, FI, GB, GD, GE, GH, GM, HR, HU, ID, IL, IN, IS, JP, KE, KG, KP, KR, KZ, LC, LK, LR, LS, LT, LU, LV, MA, MD, MG, MK, MN, MW, MX, MZ, NO, NZ, PL, PT, RO, RU, SD, SE, SG, SI, SK, SL, TJ, TM, TR, TT, TZ, UA, UG, UZ, VN, YU, ZA, ZW.
- (25) Filing Language: English
- (26) Publication Language: English
- (30) Priority Data: 60/216,662 6 July 2000 (06.07.2000) US
- (71) Applicant: **INVERTIX CORPORATION** [US/US]; Suite 500, 7630 Little River Turnpike, Annandale, VA 22003 (US).
- (72) Inventors: **XANTHOS, James**; 10673 Glen Hannah Drive, Laurel, MD 20723 (US). **MCDOWELL, Mark**; 5008 John Ticer Drive, Alexandria, VA 22304 (US). **STEAD, Graham**; 124 B North Bedford Street, Arlington, VA 22201 (US). **KHALIL, Joseph**; Apartment 155, 3305 Wyndham Circle, Alexandria, VA 22302 (US). **HELINSKI, David**; 5709 North 15th Road, Arlington, VA 22205 (US). **KITCHELL, Joseph**; 5413 Sourgum Drive, Centreville, VA 20120 (US).
- (84) Designated States (*regional*): ARIPO patent (GH, GM, KE, LS, MW, MZ, SD, SL, SZ, TZ, UG, ZW), Eurasian patent (AM, AZ, BY, KG, KZ, MD, RU, TJ, TM), European patent (AT, BE, CH, CY, DE, DK, ES, FI, FR, GB, GR, IE, IT, LU, MC, NL, PT, SE, TR), OAPI patent (BF, BJ, CF, CG, CI, CM, GA, GN, GW, ML, MR, NE, SN, TD, TG).

**Published:**

— without international search report and to be republished upon receipt of that report

For two-letter codes and other abbreviations, refer to the "Guidance Notes on Codes and Abbreviations" appearing at the beginning of each regular issue of the PCT Gazette.



**WO 02/05486 A2**

(54) Title: BITWISE MONITORING OF NETWORK PERFORMANCE

(57) Abstract: The present invention provides for a method and system for measuring data quality of service in a wireless network using multiple peripatetic (i.e. mobile) and/or stationary, unattended, position, and performance instruments (PUPPIs) that are remotely controlled by a back end processor. In some embodiments of the invention, the data service whose quality is measured relates to wireless Internet access, e-commerce transactions, wireless messaging, or push technologies. In other embodiments of the invention, the system includes an element that is located within the wireless network infrastructure, for example, at the WAP gateway to monitor the wireless data protocol and to perform benchmarking measurements.

## BITWISE MONITORING OF NETWORK PERFORMANCE

### CROSS REFERENCE TO RELATED APPLICATIONS

1. This application claims priority from U.S. provisional application no. 60/216,662, filed July 6, 2000. The 60/216,662 application is incorporated by reference herein, in its entirety, for all purposes.

### INTRODUCTION

2. The present invention relates generally to a method and system for measuring quality of service in a wireless network. More particularly, the present invention relates to a method and system for measuring quality of service in a wireless network using multiple remote units and a back end processor.

### BACKGROUND OF THE INVENTION

3. There are two major technical fields that have shown explosive growth over the past few years: the first is wireless communications and the second is use of data services, particularly the Internet. These two technical fields both require a set of specialized tools in order to measure their quality of service. Interestingly, wireless communications and data services are beginning to converge. *Unfortunately, this convergence has not been accompanied by the development of appropriate specialized tools to measure data quality of service in the wireless network.*

4. The growth of wireless communications has been astounding. Twenty years ago, there was *virtually no use of wireless communications devices such as cellular phones.* In contrast, the market penetration for wireless devices in the U.S. in 1999 was 32 percent. The current forecast is that 80 percent of the U.S. population will be wireless subscribers by 2008.

5. There are a variety of specialized tools that are used to measure quality of service over wireless networks. These include the following (just to name a few examples):

Ascom QVoice (including QVoice unattended);

Ericsson TEMS, RSAT-2000, Benchmark, CellAD, and CeNA;

Nokia TOM;

Safco VoicePrint, DataPrint, and WalkAbout;

Comarco BaseLINE and Gen II;  
Grayson Surveyor;  
ZK CellTest DX136 and DXC;  
Ameritec Swarm;  
Neopoint Datalogger; and  
Qualcomm QCTest Retriever and QCTest CAIT.

6. The general deficiency with these tools is that they were primarily developed to measure voice quality and/or RF parameters over the wireless system and not to measure data quality. Some of them have been modified to include some rudimentary data measurements; however, they are not optimized for performing wireless data measurements. In particular, they do not allow unattended measurement of wireless data from multiple remote units in a statistically significant manner with remote control from a back end processor.

7. The classical way of measuring voice quality of service and/or RF parameters in a wireless network involves sending out technicians to drive test the network. The drive test includes placing the test instrument in a vehicle and running a test script that either generates or receives a voice test signal. The receiving end of the communication link uses a DSP containing a model of human hearing to analyze the received voice sample and produce an associated quality score. In addition, some of the systems measure other system parameters such as SINAD, noise, distortion, received signal level, and call progress statistics.

8. Unfortunately, the classical method of measuring voice quality of service and/or RF parameters does not function very well for measuring data quality of service. In order to make statistically significant measurements of data quality of service over a wireless network, it is necessary to make multiple measurements from multiple remote devices. Furthermore, a measurement of data quality is inherently different from the other types of measurements due to the effects of latency and other effects that are specific to data.

9. Most of the existing measurement devices do not have this capability for a variety of reasons. The price of the test instruments range anywhere from \$5K to \$100K. This makes it price prohibitive to field a statistically significant fleet of remote devices. Thus,

what is needed are remote devices designed for unattended operation that is remotely controlled by a back end processor in order to reduce manpower costs. Additionally, what is needed are remote devices that are optimized for performing measurements that are useful over wireless data networks, such as latency for Web page access or delay in SMS message delivery.

10. The growth of data services has been just as astounding as the growth rate for the wireless industry. The largest driving force behind the growth of data services has been the enormous growth of the Internet. For example, there were 130 Web sites in June 1993, 230,000 Web sites in June of 1996, and 10 million Web sites at the end of 1999.

11. There have been a variety of specialized tools developed to measure the data quality of service over the Internet.

12. U.S. Patent No. 6,006,260 to Barrick, Jr. et al. (assigned to Keynote Systems, Inc) discloses a method for gathering latency experienced by a user over a network. The steps of the method include a user browser sending a GET command to retrieve an HTML page with an embedded Java script. The Java script starts a timer and generates a GET command to retrieve an HTML page. When the page is received, the timer is stopped and the timer information along with cookie data stored on the browser machine is sent to a relay server that logs the information.

13. U.S. patent No. 5, 657,450 to Rao et al. teaches the provision of time estimates for long-running distal source access operations using an intermediate server close to the client workspace.

14. U.S. patent No. 5, 796, 952 to Owen et al. discloses a method for monitoring a user's time of page browsing.

15. U.S. patent No. 6, 012,096 to Link et al. teaches a method for monitoring client-to-client network latency for gaming applications. The method involves a ping, response, and response-response protocol.

16. Unfortunately, none of these patents teach a method which is appropriate for performing data quality of service measurements over a wireless network.

17. As previously mentioned, there is a tremendous convergence taking place that combines the wireless network with data services. Dataquest estimates that the U. S. wireless data market (including phones, PDAs, laptops, and the like.) will grow from 3 million subscribers in 1999 to 36 million subscribers in 2003. Ericsson is estimating that 1 billion wireless units will be in use worldwide by 2003 and that 40 percent (400 million) of these units will be employed by data users. Furthermore, Ericsson is predicting that 2003 will be the crossover year in which wireless Web access will exceed wired Web access.

18. As a further measure of the explosive growth of the convergence of the wireless systems and the Internet, one can look at projections for the number of wireless portal subscribers. According to the Strategis Group, the number of wireless portals will increase from 300,000 in 2000, to 9.8 million in 2003, and finally to 24.8 million in 2006.

19. A variety of technical advancements have accelerated the convergence of Internet access over wireless devices. In 1997, three competing handset vendors (Nokia, Ericsson, and Motorola) and a small software company (Phone.com, formerly Unwired Planet) joined forces to create a standard way to transmit Internet data to wireless phones without occupying too much bandwidth. The result of this collaboration was development of the wireless application protocol (WAP). One basic component of WAP was development of the WML (Wireless Markup Language, replacing the previous Phone.com Handheld Device Markup Language, HDML) that compresses Web content in comparison to HTML. Additionally, the WAP forum developed standards for the use of microbrowsers in mobile devices.

20. Unfortunately, the development of wireless Web access technology has significantly outpaced the development of wireless data measurements tools. Accordingly, there is a tremendous need for specific test tools to address the converging technologies of wireless systems and data communications.

#### **SUMMARY OF THE INVENTION**

21. In order to meet this need, a measuring tool is provided for measuring data quality of service over the wireless network. This tool was designed from the ground up with a variety of specific attributes.

22. The present invention provides for a method and system for measuring data quality of service in a wireless network using multiple peripatetic (i.e. mobile) and/or stationary, unattended, position and performance instruments (PUPPIs) that are remotely controlled by a back end processor. According to some embodiments of the invention, the data service whose quality is measured relates to wireless Internet access, e-commerce transactions, wireless messaging, or push technologies. According to other embodiments of the invention, the system includes an element that is located within the wireless network infrastructure, for example, at the WAP gateway to monitor the wireless data protocol and to perform benchmarking measurements.

23. The remote unit is able to provide an appropriate statistical distribution for data measurements. The remote units can be peripatetic (i.e. mobile) so that they are able to roam over a statistically significant geographical area, or stationary with pre-planned location at statistically significant points, or some combination of mobile and stationary.

24. Furthermore, the system includes multiple remote units that are unattended and are remotely controlled by a back end processor. This allows for a large quantity of measurements to be taken in a fully automated manner.

25. Additionally, each of the remote units provides position information for each measurement as well as performance information that is related to wireless data. More specifically, the performance information may be related to wireless Internet access, e-commerce transactions, or wireless messaging using either push or pull technologies.

26. For example, one of the most critical measurements for the wireless Internet user is a measurement of the latency, i.e. the amount of time it takes to receive a response after a GET command is sent. In the case of wireless messaging, the latency measurement includes the amount of time required to receive information after it is sent from the source.

27. In addition, it is useful to perform measurements which divide the network into a wireless and wired portion and that provide separate measurements for each portion. Accordingly, the system may include an element that is located within the wireless network infrastructure, for example at the WAP gateway, to monitor the wireless data protocol and to perform benchmarking measurements.

28. Accordingly, an object of the present invention is to provide a method and system for measuring data quality of service in a wireless network using multiple remote units and a back end processor.
29. A further object of the invention is to perform these measurements on a variety of different types of traffic wireless networks, such as iDEN, CDMA, TDMA, and GSM, for example.
30. Another objective of the invention is to perform these measurements during a variety of different types of communications such as circuit switched calls, packet data calls, SMS messages, wireless internet access, wireless internet transactions (including e-commerce), and during the reception of push data (i.e. data which is delivered using push technology).
31. A further objective of the invention is to collect a variety of different types of measurements such as latency measurements, reliability (e.g. BER/FER), layer 3 network information, RF information, call connection information, and the like.
32. Another objective of the invention is to use control links that are either wired or wireless.
33. A further objective of the invention is to use remote units that are either mobile, stationary, or some combination of mobile and stationary so that they provide statistically significant measurements.
34. Another object of the invention is to provide a back end which allows user access through the Internet, allows for post-processing of the received data, allows for scheduling collection missions based on available resources, and allows for generation of test traffic.
35. An additional object of the invention is to provide a remote unit that allows for storage and pre-processing of the measured data, battery backup, and an RF scanner.
36. Advantages of the current invention include the ability to collect statistically significant data in an extremely cost effective and easy to use manner.
37. Additional objects and advantages of the present invention will be apparent in the following detailed description read in conjunction with the accompanying drawing figures.



**BRIEF DESCRIPTION OF THE DRAWINGS**

38. FIGS. 1a-g show a generic communication network with a variety of wireless communication paths connected to the Internet.
39. FIG. 1a shows the communication path for the traffic data in a standard wired Internet measurement system.
40. FIG. 1b shows the communication path for the traffic data during a circuit switched data connection in accordance with an embodiment of the invention.
41. FIG. 1c shows the communication path for the traffic data during a packet switched data connection in accordance with an embodiment of the invention.
42. FIG. 1d shows the communication path for the traffic data during an SMS message transmission in accordance with an embodiment of the invention.
43. FIG. 1e shows the communication path for the traffic data during a WAP data connection in accordance with an embodiment of the invention.
44. FIG. 1f shows the communication path for the traffic data during a WAP data connection in accordance with a further embodiment of the invention.
45. FIG. 1g shows the communication path for the traffic data during a WAP data connection, including a WAP monitoring processor, in accordance with a further embodiment of the invention.
46. FIG. 1h shows the communication path for the control link in accordance with an embodiment of the invention.
47. FIG. 2a shows the system architecture in accordance with one embodiment of the invention.
48. FIG. 2b shows the system architecture in accordance with a further embodiment of the invention.
49. FIG. 2c shows the system architecture in accordance with another embodiment of the invention.
50. FIG. 2d shows the system architecture in accordance with a further embodiment of the invention.

51. FIG. 2e shows the system architecture in accordance with another embodiment of the invention.
52. FIGS. 3a through 3d show a variety of basic architectures for remote units according to various embodiments of the invention.
53. FIG. 3a shows the basic architecture for the remote unit in accordance with one embodiment of the invention.
54. FIG. 3b shows another architecture for the remote unit with separate control link modem and traffic modem according to an alternate embodiment of the invention.
55. FIG. 3c shows another architecture for the remote unit with separate control link modem and multiple traffic modems according to another alternate embodiment of the invention.
56. FIG. 3d shows a further architecture for the remote units that include multiple peripherals in accordance with one embodiment of the invention.
57. FIGS. 4a through 4d show a variety of alternate implementations for the remote unit in accordance with one embodiment of the invention.
58. FIG. 4a shows a hardware implementation of the remote unit using either a laptop or handheld unit in accordance with one embodiment of the invention.
59. FIG. 4b shows a hardware implementation of the remote units using a single board computer (SBC) in accordance with one embodiment of the invention.
60. FIG. 4c shows the organization of the software-defined radio in accordance with an embodiment of the invention.
61. FIG. 4d shows the organization of the software in the remote unit in accordance with an embodiment of the invention.
62. FIG. 5a shows the architecture of the back end processor in accordance with one embodiment of the invention.
63. FIG. 5b shows the architecture of the back end processor in accordance with an alternate embodiment of the invention.

64. FIG. 5c shows the architecture for the portal in accordance with one embodiment of the invention.
65. FIG. 6a shows examples of some of the fields in the remote unit originated packets (both data and signaling) in accordance with one embodiment of the invention.
66. FIG. 6b shows examples of some of the fields in the back end processor originated packets (both data and signaling) in accordance with one embodiment of the invention.
67. FIG. 7a shows a method for measuring data quality of service in a wireless network in accordance with one embodiment of the invention.
68. FIG. 7b shows a method for measuring data quality of service in a wireless network, including at least one step related to the wireless network infrastructure, in accordance with an alternate embodiment of the invention.
69. FIG. 7c shows a method for measuring data quality of service in a wireless network, including at least one additional order independent step, in accordance with another embodiment of the invention.
70. FIG. 8a shows a bar graph output of download times from different portals in accordance with an embodiment of the invention.
71. FIG. 8b shows a bar graph output of download times across different wireless networks in accordance with an embodiment of the invention.
72. FIG. 8c shows a bar graph output of call completion percentage across different wireless networks in accordance with an embodiment of the invention.
73. FIG. 8d shows a trending graph output of call completion percentage across different wireless networks in accordance with an embodiment of the invention.
74. FIG. 8e shows a bar graph output of average download times with a breakdown of the network latency at the WAP gateway in accordance with an embodiment of the invention.
75. FIG. 8f shows a pie chart of error statistics for wireless access of Yahoo in accordance with an embodiment of the invention.

76. FIG. 9 illustrates a system according to an exemplary embodiment of the present invention.
77. FIG. 10 illustrates remote units (PUPPIs) in the exemplary system.
78. FIG. 11 illustrates processes that each contain software modules that are responsible for specific tasks.
79. FIG. 12 illustrates a router is used as the interface between an external communication line and a LAN that is connected to the PUPPIs.
80. FIG. 13 illustrates the basic architecture for the Back End according to the exemplary embodiment.
81. FIG. 14 illustrates two basic software modules included in the Back End.
82. FIG. 15 illustrates hardware architecture for the Back End according to the exemplary embodiment.

## DETAILED DESCRIPTION

### I. OVERVIEW

83. In order to understand the present invention, it is helpful to compare the communication path of current data measurements tools with the communication path in accordance with several embodiments of the invention. FIGS. 1a-g show a generic communication network with a variety of wireless communication paths connected to the Internet. It is well known to those of ordinary skill in the art that these figures illustrate a generic network that is used for illustrative purposes. For example, in some cellular networks there is a base station controller connected to multiple base stations between their connections to the MSC. As another example, the WAP gateway, packet data gateway, and PSTN connection may be replaced in some wireless networks by a single device that is directly connected to the MSC.

84. FIG. 1a shows the communication path (heavy broken line) for the traffic data in a standard wired Internet measurement system. The traffic data flows between the user machine **124** over the Internet **122** to a standard application server **126** that will generally be serving an HTML page.

85. FIG. 1b shows the communication path (heavy broken line) for the traffic data during a circuit switched data connection in accordance with an embodiment of the invention. The traffic data passes from the remote unit **102-1** to the base station **106**, MSC **108**, PSTN **110**, ISP **112**, Internet **122**, and to a standard application server **126**. The standard application server **126** may be serving an HTML page, for example.

86. FIG. 1c shows the communication path (heavy broken line) for the traffic data during a packet switched data connection in accordance with an embodiment of the invention. The traffic data passes from the remote unit **102-1** to the base station **106**, MSC **108**, operator backbone **114**, packet data gateway **118**, Internet **122**, and standard application server **126**. For example, the standard application server **126** may be serving an HTML page.

87. FIG. 1d shows the communication path (heavy broken line) for the traffic data during an SMS message transmission in accordance with an embodiment of the invention. If the SMS message is being delivered to the remote unit **102-1**, the traffic data passes from a standard application server **126** to the Internet **122**, SMSC **116**, operator backbone **114**, MSC **108**, base station **106**, and remote unit **102-1**.

88. FIG. 1e shows the communication path (heavy broken line) for the traffic data during a WAP data connection in accordance with an embodiment of the invention. If the remote unit **102-1** is accessing a WAP server **128**, the traffic data passes from the remote unit **102-1** to a base station **106**, MSC **108**, operator backbone **114**, WAP gateway **120**, Internet **122**, and WAP server **128**. For example, the traffic data path shown in FIG. 1e allows for latency measurements for wireless Web page access or e-commerce transactions.

89. It is important to note that although the term WAP is being applied to the wireless Internet protocol, the principles of the present invention are not limited to a WAP implementation. The present invention may be implemented using any wireless Internet protocol, including HDML and any future wireless Internet protocols that may be developed. The following examples are provided of some competing technologies that for the purposes of this disclosure will be considered to be functionally equivalent to WAP. For example, the Web content can be delivered as text messaging or as an SMS message

(as proposed by Xypoint or GoSMS) so that it is compatible with existing cellular phones. Alternatively, the Web content can be delivered as existing HTML Internet content for wireless devices as proposed by Spyglass' Prism technology or Japan's iMode. As a further example, the content can be processed through a template model that reads existing HTML content and fits the data to a template optimized for various types of wireless phones such as the system proposed by Everypath.com. As another example, the data content can be delivered to a Palm Pilot or other PDA or handheld device that uses a proprietary protocol.

90. Additionally, it is noted that the present invention is not limited to use of the Internet, as it may be effectively practiced using any broad-reach network regardless of hardware implementation specifics. Accordingly, the term Wireless Data Protocol (WDP) will be used interchangeably with the generically used term WAP to describe the protocol used for wireless data access.

91. FIG. 1f shows the communication path (heavy broken line) for the traffic data during a WAP data connection in accordance with a further embodiment of the invention. If the remote unit **102-1** is accessing the benchmark WAP server **130**, the traffic data passes from the remote units **102-1** to a base station **106**, MSC **108**, operator backbone **114**, WAP gateway **120**, and to the benchmark WAP server **130**. This configuration allows latency measurements without including the uncertainties of the latency through the Internet **122** itself. In other words, the configuration in FIG. 1f allows measurements of the latency due to the wireless network itself with no contribution from the Internet **122**.

92. FIG. 1g shows the communication path (heavy broken line) for the traffic data during a WAP data connection, including a WAP monitoring processor **132**, in accordance with a further embodiment of the invention. The WAP monitoring processor **132** may be implemented as monitoring software installed and running on the WAP Gateway **120** or as software installed on a separate machine attached to the WAP Gateway **120**. The software would monitor traffic through the WAP Gateway **120** and provide metrics such as throughput, latency and lost packet information. This configuration would allow the wireless network and the Internet **122** itself to be analyzed and monitored separately, thus providing performance information for each. Furthermore, the WAP Monitoring

Processor **132** would be able to collect protocol information directly from the WAP Gateway **120** that may not be available to the multiple remote units (**102-1** through **102-N**).

93. The monitoring software may run as a separate application on the WAP Gateway **120**, or may be embedded into the WAP Gateway software itself and run as part of the entire gateway application. The monitoring software would have a mechanism for collecting metrics and passing that information to the back end processor through the internet, wireless network, or through some other means. The monitoring software may temporarily store results locally, and perform some pre-processing on the data prior to forwarding it to the back end processor.

94. FIG. 1h shows the communication path for the control link in accordance with an embodiment of the invention. The control link is used to remotely control the remote units **140, 142, 144, 146** from the back end processor **148**. Specifically, the process in the back end processor **148** that communicates with the remote units **140, 142, 144, 146** is the fleet management process, which will be discussed in detail later.

95. The remote units can be either mobile **140, 142, 144** or stationary **146**. The mobile units **140, 142, 144** can be mounted in a variety of vehicles such as taxis, police cars, buses, postal vehicles, delivery vehicles, fleet vehicles, just to give a few examples. The stationary remote units **146** can be mounted in any area in which the public congregates and uses wireless devices. This includes airports, bus stations, and train stations just to provide a few examples.

96. A variety of communication technologies are available to implement the control link. The control link can be implemented as data running over any of the current wireless networks such as CDMA, iDEN, TDMA, or GSM just to name a few examples. Additionally, the control link can be implemented over the AMPS network using CDPD for example. Alternatively, the control link can be implemented using a two-way data system such as ARDIS, MOBITEX, SKYTEL, and the like.

## II. SYSTEM ARCHITECTURE

97. FIG. 2a shows the system architecture in accordance with one embodiment of the invention. As previously described, the invention comprises multiple remote units (**202-1**

– **202-N**) that may be either mobile or stationary. Each remote unit may include a location unit (**202a-1 – 202a-N**) that allows the remote unit to accurately determine its location. Furthermore, each remote unit includes a communications link (**202b-1 – 202b-N**) that provides for both the control link and the traffic data. The communications link **202b-1** communicates over a communication network **210** that passes the information to a communication server **212** that connects to a data network **220**. The data network **220** can be a public data network, such as the Internet, or a private data network. A back end processor **224** is connected to the data network **220** for handling control link information, both commands and responses, and traffic data. In addition, the customers **222** are also connected to the data network so that they can access the back end processor **224**.

98. FIG. 2b shows the system architecture in accordance with a further embodiment of the invention. The system in FIG. 2b differs from the system shown in FIG. 2a in that the control link network and the traffic data network are two separate communication networks. Each remote unit (e.g., **202-1**) may include a location unit **202a-1** that allows the remote unit **202-1** to accurately determine its location. Furthermore, each remote unit **202-1** includes a control link communication module **202c-1** and a traffic data communication module **202d-1**. The control link **202c-1** passes commands and response information through communication network A **210A** and communication server A **212A** to the data network **220**. The traffic data communication module **202d-1** passes traffic data through communication network B (**210B**) and communications server B (**212B**) to the data network **220**. A back end processor **224** is connected to the data network **220** for handling control link information, both commands and responses, and traffic data. In addition, the customers **222** are also connected to the data network **220** so that they can access the back end processor **224**.

99. FIG. 2c shows the system architecture in accordance with another embodiment of the invention. The system shown in FIG. 2c differs from the system shown in FIG. 2b in that each remote unit (e.g., **202-1**) may have multiple traffic modules (**202d1-1 – 202dN-1**). Each remote unit **202-1** may include a location unit **202a-1** that allows the remote unit to accurately determine its location. Additionally, each remote unit **202-1** includes a control link communication module **202c-1**, and includes multiple traffic data communication modules (**202d1-1 – 202dN-1**). The control link passes command and



response information through communication network A **210A** and communication server A **212A** to the data network **220**. Each traffic data communication module 1 through N (**202d1-1 – 202dN-1**) passes traffic data through communication network B-1 (**210B-1**) through B-N (**210B-N**), respectively, and through communication servers B-1 (**212B-1**) through B-N (**212B-N**), respectively, to the data network **220**. A back end processor **224** is connected to be data network **220** for handling control link information, both commands and responses, and traffic data. In addition, the customers **222** are also connected to the data network **220** so that they can access the back end processor **224**.

100. FIG. 2d shows the system architecture in accordance with a further embodiment of the invention. The system in FIG. 2d differs from the system shown in FIG. 2c in that multiple control link communication networks may be used. This is particularly important in systems in which the remote units are deployed in different cities. It may be preferable in this case to use a different control link communication network in different cities depending on the wireless system coverage and the data pricing structure.

101. Each remote unit (**202-1 – 202-N**) may include a location unit (**202a-1 – 202a-N**) that allows the remote unit to accurately determine its location. Furthermore, each remote unit (**202-1 – 202-N**) includes a control link communication module (**202c-1 – 202c-N**) and includes multiple traffic data communication modules (**202d1-1 – 202dN-1 – 202d1-N – 202dN-N**). The control link passes commands and response information through one of communication network A-1 (**210A-1**) through A-N (**210A-N**) depending on the appropriate communication network for the specific remote unit. Each control link communication network A-1 (**210A-1**) through A-N (**210A-N**) is connected to a respective communication server A-1 (**212A-1**) through A-N (**212A-N**) which allows command and response information to be passed to the data network. Each traffic data communication module 1 (**202d1-1**) through N (**202d1-N**) passes traffic data through communication network B-1 (**210B-1**) through B-N (**210B-N**), respectively, and through communication servers B-1 (**212B-1**) through B-N (**212B-N**), respectively, to the data network. A back end processor **224** is connected to the data network **220** for handling control link information, both commands and responses, and traffic data. In addition, the customers **222** are also connected to the data network **220** so that they can access the back end processor **224**.

102. FIG. 2e shows the system architecture in accordance with another embodiment of the invention. The system in FIG. 2e differs from the system shown in FIG. 2d in that both mobile and stationary remote units are shown. Because the traffic data communication channels in FIG. 2e are the same as those in FIG. 2d, they have been omitted in order to simplify the diagram. The control links for the mobile remote units (202-1 through 202-N) are the same as those described in FIG. 2d.

103. Each stationary remote unit (202-X through 202-Y) may include a location unit (202a-X through 202a-Y) that allows the remote unit to accurately determine its location. The location unit (202a-X through 202a-Y) is generally optional in the stationary remote units since their location is presumably known. The stationary remote units each include a control link module (202c-X through 202c-Y) which is connected via a respective wired line to a respective communication network C-1 (210C-1) through C-N (210C-N) and associated communication server C-1 (212C-1) through C-N (212C-N) which allows command and response information to be passed to the data network 220. A back end processor 224 is connected to be data network 220 for handling control link information, both commands and responses, and traffic data. In addition, the customers 222 are also connected to the data network 220 so that they can access the back end processor 224.

### III. REMOTE UNIT

104. The remote unit has a variety of attributes in accordance with one embodiment of the invention. The remote unit should preferably be portable in terms of size and weight so it can be deployed in a vehicle or in a stationary public area. Possible vehicles include buses, police vehicles, taxis, postal vehicles, delivery vehicles, and fleet vehicles just to name a few. Examples of stationary public areas include airports, train stations, bus stations, and any public area where large numbers of people use wireless devices.

105. Another attribute of the remote unit is that it is mountable either in a vehicle or in a public area. There are a variety of methods that can be used for mounting the remote unit. For example, the remote units can be mounted to a DIN bar that is commonly used for industrial equipment. Alternatively, the remote units can be mounted using a standard bracket, tie device, fabric strap, bolts, or adhesive device such as Velcro, for example.

106. A further attribute of the remote unit is that it is able to withstand a wide

temperature range such as the industrial temperature range of -40 degrees C to + 80 degrees C, for example. This attribute allows deployment of the remote unit in a wide range of geographical environments. Furthermore, it allows deployment of the remote unit in places such as the trunk of a vehicle in which airflow is limited.

107. Another attribute of the remote unit is the ability to withstand vibration. This attribute is important since many of the remote units may be deployed in vehicles and will be subjected to severe vibration. There are a variety of standard techniques that can be used to improve the vibration performance of the remote unit. These include using frequency absorbing mounting materials and potting the components on the printed circuit board for added stability.

108. A further attribute of the remote unit is that it meets all local standards for emissions, both radiated and conductive. For example in United States, the emissions from most digital devices are covered by FCC part 15 and emissions from cellular devices are covered by FCC part 22. In Europe, there generally are directives which cover radiated emissions, conductive emissions, and radiated immunity and which must be met in order to receive the CE mark.

109. Another attribute of the remote unit is the ability to handle the input power source. First, the remote unit should include some type of power regulation. This is particularly important in a vehicular environment in which the power provided by the vehicle battery is very noisy. Additionally, the remote unit should include the ability to power any external modules or peripherals that are going to be attached to the main control unit. Furthermore, the remote units may include some form of battery backup with an automatic charger so that the remote unit in a mobile environment does not drain the vehicle battery when the ignition is turned off. This requirement is not as important in a stationary deployment since the power can be provided from an AC outlet using a DC transformer. However, one may choose to include the battery and charger in this configuration also in order to provide battery backup in the event of an AC power failure. Finally, the remote unit may include some form of sleep mode which is used to conserve power during periods of sporadic activity.

110. The remote unit will now be described with regard to a variety of embodiments in

accordance with the invention. FIGS. 3a through 3d show a variety of basic architectures for the remote unit. FIGS. 4a through 4d show a variety of possible implementations for the remote unit.

111. FIG. 3a shows the basic architecture for the remote unit in accordance with one embodiment of the invention. The remote unit **300** comprises a control unit **302**, a location unit **304**, and a control link and traffic modem **306**. The control unit **302** is the main control device for the remote unit **300** and is connected to the location unit **304** and the control link and traffic modem **306**. The location unit **304** determines the location of the remote unit **300**.

112. The control link and traffic modem **306** shown in FIG. 3a is used to communicate with the back end processor **224**. The control link and traffic modem **306** is connected to the control unit **302** in order to send and receive control information and traffic information. The control unit is generally running a main program that controls the location unit **304** and the control link and traffic modem **306**.

113. There are a variety of ways in which the location unit **304** can determine the location in accordance with the invention. The location unit **304** may comprise a GPS receiver such as those manufactured by Trimble, Ashtech, Garmin, or Magellan, for example. If the location unit **304** is a GPS receiver, the connection to the control unit **302** may be a serial communication link. In another embodiment, the location unit **304** may comprise a GPS daughterboard such as those manufactured by Avocet, Trimble, Ashtech, or Rockwell, for example. If the location unit **304** is a GPS daughterboard, the connection to the control unit **302** is usually through a proprietary connector mounted on the control unit **302**. The control of the GPS daughterboard is generally accomplished using a serial connection. In a further embodiment of the invention, the location unit **304** may comprise a GPS chipset or a single GPS chip which is mounted directly on the control unit **302** and which has a bus interface. Furthermore, any of the GPS implementations of the location unit can include differential GPS using RTCM or RTCA corrections or alternatively can include WAAS capabilities.

114. It is well known to those of ordinary skill in the art that there are a variety of alternative implementations for the location unit that don't involve standard GPS. For

example, one can use a distributed GPS system, such as the one developed by SnapTrack, in which part of the GPS functionality is handled by a centralized server. Another alternative location option is the use of a triangulation technique using either angle of arrival or time difference of arrival information. Although the generic term triangulation is used, there is no requirement that three measurement points be used. A further location option is the use of RF fingerprinting, such as that developed by U.S. Wireless, which determines the unit location based on a multipath signature.

115. Those of ordinary skill in the art will understand that FIGS. 2a-e, 3a-d, and 4a show logical antennas rather than physical antennas. These logical antennas can be combined in virtually any combination into a single physical antenna or groups of physical antennas depending on the specific requirements.

116. FIG. 3b shows another architecture for the remote unit **300** with separate control link modem **308** and traffic modem **310** in accordance with a further embodiment of the invention. FIG. 3b differs from FIG. 3a in that the single control link and traffic modem **306** has been divided into a separate control link modem **308** and traffic modem **310**. The advantage of separating the control link modem **308** from the traffic modem **310** is that it allows the remote unit **300** to communicate control information and traffic information over different communication networks.

117. It is well known to those of ordinary skill in the art that there are variety of implementations for both the traffic modem and the control link modem that will be referred to collectively as modem units. In one embodiment of the invention, the modem units may comprise a handset that is connected to the control unit using a special serial cable. In an alternative embodiment of the invention, the modem units may comprise a modem module that is connected to the control unit using a special serial cable. In another embodiment of the invention, the modem units may comprise a PCMCIA card that is connected to the control unit using a PCMCIA socket. In a further embodiment of the invention, the modem units may comprise a custom modem that is implemented on either a separate printed circuit board or on the same printed circuit board as the control unit. In another embodiment of the invention, the modem units may comprise a software-defined radio (SDR) in which most of the radio functionality is implemented in software. The

software can be running either on a separate printed circuit board or on the same printed circuit board as the control unit. In an alternative embodiment of the invention, the control link modem may comprise a 2-way data device, such as the RIM Blackberry or Motorola CreaLink, which interfaces to the control unit via a serial connection.

118. The traffic modem **310** is selected so that it can work over a wireless network using a particular wireless standard. For example, the wireless network can be AMPS, iDEN, CDMA, TDMA, GSM, ARDIS, MOBITEK, or CDPD. It should be noted that these standards are listed as examples and are not meant to limit the scope of the invention. It is well known to those of ordinary skill in the art that other wireless network standards such as W-CDMA, PHS, i-Burst, NAMPS, ETACS, WLL, UMTS, TETRA, and NMT may also be supported just to name a few more examples.

119. The traffic modem **310** may implement more than one wireless standard. For example, QUALCOMM manufactures dual mode phones that support both CDMA and AMPS operation. In addition, if the traffic modem **310** is implemented using a software-defined radio then it is possible to implement all of the above-mentioned standards using a single hardware platform.

120. The control link modem **308** is also selected so that it can work over a wireless network using a particular wireless standard. For example, the wireless network can also be AMPS, iDEN, CDMA, TDMA, GSM, ARDIS, MOBITEK, or CDPD. A primary factor in selecting a wireless standard for the control link modem is the pricing policy for transmitting control link information.

121. FIG. 3c shows another architecture for the remote unit **300** with a control link modem and multiple traffic modems **310-1 – 310-N** in accordance with a further embodiment of the invention. FIG. 3c differs from FIG. 3b because it includes multiple traffic modems rather than a single traffic modem. The remote unit **300** architecture of FIG. 3c includes a control unit **302** that is connected to a location unit **304**, control link modem **308**, and traffic modems 1 (**310-1**) through N (**310-N**).

122. FIG. 3d illustrates a remote unit according to one embodiment of the present invention that includes multiple peripherals. The remote unit **300** architecture of FIG. 3d includes a control unit **302** that is connected to a location unit **304**, a control link modem

**308**, traffic modems 1 (**310-1**) through N (**310-N**), battery backup **312**, external storage **314**, a wireless LAN device **316**, and an RF scanner **318**. The location unit **304**, control link modem **308**, and traffic modems 1 (**310-1**) through N (**310-N**) are implemented in the same manner as discussed above with reference to FIG. 3c.

123. The battery backup **312**, shown in FIG. 3d, provides power to the remote unit **300** when the main power is not available. If the remote unit **300** is mounted in a vehicle, the battery backup **312** is used when the vehicle ignition is turned off in order to ensure that the remote unit **300** does not drain the vehicle battery while the vehicle is parked. If the remote unit **300** is mounted in a stationary location, the battery backup **312** may be used to provide power if the main power is cut off due to a power failure in the building. In accordance with one embodiment of the invention, the battery backup **312** includes a battery and a battery charger. The battery can be made from a variety of known rechargeable technologies such as sealed lead acid, NiCad, NiMH, and Lithium for example.

124. The external storage **314** provides a temporary storage capability for data that is not immediately sent back to the back end processor **224**. There are a variety of reasons for storing data in the external storage **314**. For example, if layer 3 network data is collected for the wireless network it is possible to produce 1 Mbyte/hour/technology of data. It may be prohibitively expensive to send this much data back to the back end processor **224** via the control link modem **308**. Accordingly, the data can be stored locally in the external storage **314** and be downloaded at a later time using an alternate path.

125. As another example, the collected data may be queued for transmission when the vehicle ignition is turned off. It may be preferable not to transmit the stored data until the ignition is turned back on in order to prevent unnecessary draining of the battery backup mechanism **312**. Accordingly, the data can be stored locally in the external storage **314** and queued for transmission in at a later time over the control link modem **308** when the vehicle ignition is turned on.

126. It is well known to those of ordinary skill in the art that the external storage **314** can be implemented in a variety of ways. For example, the external storage is implemented as a PCMCIA Flash card that plugs into a PCMCIA socket on the control

unit. As another example, the external storage **314** can be a SANdisk that is connected to the control unit via a proprietary connector. Alternatively, the external storage **314** is implemented using a moving storage device such as a specialized hard drive, for example a PCMCIA hard drive module. However, in mobile environments it is preferable to implement the external storage with no moving parts in order to improve the reliability of the remote unit.

127. The wireless LAN device **316** allows high-speed data transmission over short distances. In accordance with an embodiment of the invention, the wireless LAN device **316** is implemented, for example, using Bluetooth technology. The wireless LAN device **316** provides an alternative path for downloading data that is stored on the external storage **314**. For example, if the remote unit **300** is mounted in a taxi and layer 3 wireless network data is stored from an earlier collection operation, then the wireless LAN device **316** is free to communicate with a wireless LAN controller (not shown) located at the taxi dispatch center in order to transmit the data back to the back end processor **224**. As an alternative example, the wireless LAN device **316** can be used to communicate with a local I/O device (not shown) that can be used in a delivery truck to allow communications between a central dispatch and the delivery truck operator.

128. The RF scanner **318** allows increased functionality for the remote unit **300** by increasing the capabilities for performing RF optimization of the wireless network. The RF scanner **318** allows the collection of more RF data than is traditionally available through the traffic modems (**310-1 – 310-N**). For example, the RF scanner **318** has a much more flexible input bandwidth since it is not forced to listen to a single traffic channel on the wireless network. Additionally, if the RF scanner **318** is optimized for CDMA collection, it can collect a variety of valuable CDMA network parameters such as measuring  $I_o$  in the channel, despreading the spreading codes, measuring  $E_c/I_o$ , and measuring chip delay. The RF scanner **318** can be implemented by using a commercial scanner or by developing a custom scanner, for example, using a software-defined radio.

129. FIG. 4a shows a hardware implementation of the remote unit **400** using either a laptop or handheld unit **402** in accordance with one embodiment of the invention. The laptop or handheld unit **402** is connected to a GPS receiver **404**, control link modem **408**,



and traffic modem **410**. The laptop or handheld unit runs any of a variety of operating systems such as Windows 95/NT/CE, Linux, or Palm OS, for example. The peripheral devices **404**, **408**, **410** are connected to the laptop or handheld unit **402** via serial ports, PCMCIA ports, Ethernet, or USB as appropriate. The laptop or handheld unit **402** should have device drivers for all of the peripheral devices that are either built into the operating system or written in a higher-level language. Furthermore, the laptop or handheld unit **402** runs a main program that allows extraction of the location information from the GPS receiver **404** and sends and receives communication over the control and traffic channels.

130. FIG. 4b shows a hardware implementation of the remote units using a single board computer (SBC) in accordance with one embodiment of the invention. The single board computer can be purchased off-the-shelf from a variety of vendors such as SBS, ADS, or Datalogic for example. Alternatively, the single board computer can be custom designed for the specific remote unit application. FIG. 4b shows a typical architecture for the single board computer including a microprocessor **420** which is connected via an address and data bus to a boot ROM **424**, Flash memory **426**, DRAM/SRAM **428**, a PCMCIA socket **430**, a UART **432**, a USB interface **434**, an Ethernet interface **436**, a CAN interface **438**, a wireless LAN device **440**, and an optional A/D & D/A interface **442**. The microprocessor **420** may also have direct connections to a temperature sensor **444**, display interface **446**, and general-purpose I/O. Additionally, the single board computer may include power management circuitry **448** that is connected to switched power, power, and ground, and additionally connected to an optional backup battery **450**.

131. It is well known to those of ordinary skill in the art that the single board computer can be implemented using a variety of different technologies. For example, the microprocessor can be a StrongARM, ARM, Pentium, PowerPC, Motorola 68000, and the like. Furthermore, a variety of operating systems are available such as Windows CE, Windows 95/98, Windows NT, Linux, Palm OS, VXWorks, OS-9, PSOS, and the like. The serial ports from the UART **432**, or directly from the microprocessor **420**, are used to interface to peripheral devices such as the traffic modem **410** or the GPS receiver **404** and should have configurable bit rates, word size, start bits, stop bits, parity bit and the ability to operate at either TTL or RS-232 voltage levels.

132. FIG. 4c shows the organization of a software-defined radio in accordance with an alternate embodiment of the invention. All of the elements of the software-defined radio 460 can be combined in any combination depending on the requirements. The elements include an RF scanner 462, a control link modem 464, traffic modems 1 (466-1) through N (466-N), a location unit 468, and a wireless LAN device 470. The advantage of using a software-defined radio architecture is that it allows implementation of multiple standards simultaneously on a single hardware device. This can greatly reduce the cost of the remote unit. The underlying architectural concepts for the software-defined radio 460 are well known to those of ordinary skill in the art and are discussed in articles in numerous journals such as the IEEE Communications Magazine.

133. FIG. 4d illustrates organization of the software in the remote unit in accordance with an embodiment of the invention. At the lowest level is the operating system 476 that provides basic functionality for the hardware platform. The remote unit can run a variety of operating systems such as Windows 95/NT/CE, Linux, Palm OS, VXWorks, QNX, or pSOS for example. Furthermore, depending on the requirements, it is possible to use no operating system and write platform-specific code to implement the lower level routines.

134. At the next level, the remote unit software includes device drivers 478, utilities 480, protocols, 482 and user interface modules 484. The device drivers 478 allow communication with the peripheral devices such as the GPS receiver 404 and the wireless modems, for example. The utilities 480 support lower-level functions such as encryption and compression, for example. The protocols 482 support any protocols that are needed in the remote unit such as a WAP browser, TCP/IP, X.25, and any proprietary packet protocols, for example. The user interface module 484 includes all of the functionality required for local control of the remote unit such as a simple menuing system. It is well known to those of ordinary skill in the art that some or all of these modules may also be built into the operating system.

135. At the next level, the remote unit software optionally includes a variety of additional modules such as a pre-processing module 486, DB/Storage module 488, and a software-defined radio module 490. The pre-processing module 486 may be used to pre-process the collected data. This is particularly helpful in an operational scenario in which

large quantities of data are collected and need to be reduced in order to conserve control link bandwidth. The DB/Storage module **488** may be used to store and organize the requested missions and/or the collected data. The software-defined radio module **490** is implemented as described above with reference to FIG. 4c.

136. The main application **492** is at the next level and performs the higher-level routines. For example, the main application **492** is used to receive missions over the control link, execute the missions, and transmit the mission data over the control link.

137. In the implementations described above, the control unit **302** is shown as being a general purpose computer in the form of a laptop or handheld unit **402**. Although this has certain advantages in terms of flexibility of programming, the invention may also be implemented using special purpose computers in lieu of general purpose computers.

#### IV. BACK END PROCESSOR

138. FIG. 5a shows the architecture of the back end processor **500** in accordance with one embodiment of the invention. The back end processor **500** includes the following processing elements: fleet management **502**, test traffic generator **504**, post processor **506**, user interface **508**, portal **510**, mapping **512**, and billing and accounting **514**. These processing elements are interconnected by a data network **516**. It is well known to those of ordinary skill in the art that the data network **516** can be either a LAN, WAN, inter processing communications within a computer or network, or any combination of the above.

139. FIG. 5b shows the architecture of the back end processor **500** in accordance with a further embodiment of the invention. The back end processor includes the following processing elements: fleet management **530**, test traffic generator **532**, post processor **534**, user interface **536**, and portal **538** including a mapping element **538a** and a billing and accounting element **538b**. In addition, the fleet management element **530** is connected to a collected data database **540**, mission database **542**, and remote unit database **544**; the post-processing element **534** is connected to a post-processed database **546** and the collected data database **540**, and the portal **538** is connected to a mapping database **548** and a billing and accounting database **550**.

140. The fleet management element **530** is the main interface in the back end processor

for communicating with the remote units. The fleet management element keeps track of the remote units by accessing data in the remote unit database 544, performs mission planning and coordination based upon information provided from the user interface 536, sends and receives information to the test traffic generator 532 in order to generate terrestrial originated calls, and sends and receives commands and responses to the remote units via the control link.

141. The fleet management element 530 receives mission requests from the user interface 536 and stores the information in the mission database 542. It then performs a scheduling function based on the requested missions stored in the mission database 542 as compared with the remote units available as determined by availability information stored in the remote unit database 544. The scheduled missions are stored in the mission database 542 as requested missions and are sent at the appropriate time to the remote units over the control link. The requested missions can be stored and sent as a batch of missions or can be sent as individual missions depending on the requirements.

142. The information received by the fleet management element 530 is stored in the collected data database 540 and forwarded to the post processor element 534 that stores raw mission data and also performs post processing and stores the post processing results.

143. The post processing involves processing of the received data for either RF/network parameters related to the wireless system or statistical information related to the wireless data access.

144. The analysis of the RF/network parameters can be accomplished in a variety of ways such as those discussed in Provisional Patent Application No. 60/149,888 entitled "Wireless Telephone Network Optimization" that was filed on August 19, 1999, and which is incorporated by reference herein in its entirety for all purposes. This provisional disclosure provides a simulation environment to develop optimum coverage-related parameters for sectors of a wireless network. This simulation environment allows a network engineer to vary parameters of a virtual model of the wireless network and observe how the changes affect coverage. The provisional disclosure further provides an optimization algorithm to optimize hand off timing parameters for sectors in a wireless network. The optimization algorithm analyzes measured data regarding network coverage

and regional terrain to arrive at a report containing recommended values for window size parameters (code division systems) or time advance parameters (time division systems).

145. The post processing for statistical analysis involves the wireless data access that is accomplished using the traffic modem in the remote unit. The statistical analysis allows the combination of various collected information in order to produce reports for specific customers. For example, the latency of WAP accesses to a specific URL is measured over several different wireless networks and displayed on a bar graph. Further examples of statistical analysis and report generation are discussed in the operation section with respect to FIGS. 8a-8f.

146. The user interface element **536** is connected to the fleet management element **530** in order to schedule missions based on requirements entered by the customers. Additionally, the user interface element **536** is connected to the post-processing element **534** to allow users to generate special queries, access previously stored queries, or access reports that are generated from the post processed data. The user interface element **536** is also connected to the portal **538** to allow access for the customers **560** from a connected data network such as the Internet **562**.

147. The portal element **538** acts as an operating system providing a variety of low-level functions for multiple applications. The portal **538** includes a mapping element **538a** and a billing and accounting element **538b**. The portal **538** is connected to databases **548**, **550** for the mapping information and the billing accounting information. In addition, the portal **538** is connected to the data network **562**, such as the Internet, to allow customer entry into the system. The portal is also connected to the post processor **535** to allow access of the post-processed data for visualization with the mapping software, for example.

148. FIG. 5c shows the architecture for the portal **570** in accordance with one embodiment of the invention. The portal **570** acts as an operating system providing common low-level functions for a variety of applications and acting as an interface for customer access through the Internet. The portal **570** functions are organized into four major groups: databases **572**, GUI controls **574**, workgroup functions **576**, and security **578**. The database **572** functions include terrain, morphology, buildings, and billing and accounting. The GUI controls **574** include mapping/GIS, charts, and virtual reality. The

workgroup functions **576** include access controls and threaded dialogue. The security functions **578** include login, partitioning, and audit trails. The portal also includes an API **580** that allows access to various applications.

#### IV. CONTROL LINK COMMUNICATION PROTOCOL

149. The control link allows communications between the multiple remote units and the back end processor. There are a variety of possible protocols for the control link. The communication protocol can be a standard protocol such as TCP/IP, WAP, or X.25, for example, or a proprietary protocol that is optimized for the required communications, or some combination of a standard and proprietary protocol.

150. In accordance with one embodiment of the invention, a proprietary packet protocol is used. One issue regarding the packet protocol is the issue of acknowledgments for packets.

151. Acknowledgments can be handled in a variety of ways. They can be sent as an individual packet for each substantive packet sent. This is the heartiest mechanism but it is bandwidth inefficient. Alternatively, acknowledgments can be sent as a field of a subsequent packet using a packet numbering scheme to indicate which previous packet is being acknowledged. This method requires more overhead at each end of the communication link in order to keep track of previously sent packets, but is more efficient in terms of bandwidth used. As another alternative, the acknowledgment system can be handled by the communication system itself so that the packet protocol does not have to address the issue. For example, many two-way data systems have a built-in acknowledgment system so that packet delivery is virtually guaranteed. In this case, it is not required to include acknowledgments in the packet protocol since they are handled at another level.

152. There are two basic types of packets: signaling packets and data packets

153. The signaling packets are originated either at the remote unit or at the back end processor. Some examples of remote unit originated packets are ignition on, ignition off, and status update. The Ignition on packet indicates that the vehicle ignition has been turned on and the ignition off packet indicates that the vehicle ignition has been turned off. These packets are used by the back end processor in order to properly schedule data

collection in a mobile remote unit. The status update packet indicates the current status of the remote unit.

154. Some examples of back end originated packets are reset and status request. The reset packet is used to remotely reset the remote unit. The status request packet is used to remotely request status information for a remote unit.

155. The data packets are also either originated at the remote unit or at the back end processor. The back end originated data packets generally consist of mission requests and the remote unit originated data packets generally consist of mission data.

156. FIG. 6a shows examples of some of the fields in the remote unit originated packets (both data and signaling) **610** in accordance with one embodiment of the invention. Some examples of the packet fields include a packet type ID **610a**, remote unit ID **610b**, date and time **610c**, message number **610d**, mission ID number **610e**, location information **610f**, payload information **610g**, and checksum information **610h**. The packet type ID field **610a** indicates the type of packet so that the back end processor will know how to parse the packet for the proper fields. The remote unit ID field **610b** is used to identify the remote unit sending the packet. The date and time field **610c** indicates the date and time that the measurement is taken. The message number field **610d** is used to keep track of the message for acknowledgment purposes. The mission ID number field **610e** is used by data packets to indicate the corresponding back end mission that caused generation of the packet's payload information. The location information field **610f** indicates the remote unit location at the time of data collection. The checksum information field **610h** is used in order to ensure the integrity of the packet information. The term checksum is used generically to refer to any type of error correction and/or error detection method to ensure packet integrity.

157. The remote unit originated data packet's payload information field **610g** can take a variety of forms. It may include call statistics such as connect time, call duration, whether the call failed to connect or was dropped, and the like. Additionally, it may include basic RF engineering measurements such as RSSI, BER, FER, SQE, and the like. Furthermore, the payload information may include Layer 3 information that discloses call routing data and information regarding the configuration of the wireless network. The Layer 3

information may be collected in totality or filtered by pre-processing in the remote unit depending on the amount of information desired. In addition, the payload may include application information such as the access latency for a WAP page or the delay in receipt of an SMS message.

158. FIG. 6b shows examples of some of the fields in the back end processor originated packets (both data and signaling) **620** in accordance with one embodiment of the invention. Some examples of the packet fields include a packet type ID **620a**, remote unit ID **620b**, date and time **620c**, message number **620d**, mission ID number **620e**, payload information **620f**, and checksum information **620g**. The packet type ID field **620a** indicates the type of packet so that the remote unit will know how to parse the packet for the proper fields. The remote unit ID field **620b** is used to identify the remote unit receiving the packet. The date and time field **620c** indicates the date and time that the packet is sent. The message number field **620d** is used to keep track of the message for acknowledgment purposes. The mission ID number field **620e** is used by data packets to indicate the back end mission that will cause generation of the packet's payload information. The checksum information field **620g** is used in order to ensure the integrity of the packet information. The term checksum is used generically to refer to any type of error correction and/or error detection method to ensure packet integrity.

159. The back end processor originated data packet's payload information field **620f** can take a variety of forms. It may include mission info regarding the type of data to collect including the type of access (WAP, circuit switched data, etc), a trigger related to the time (or range of times) to make the test call, a trigger related to the location (or range of locations) to make the test call, a wireless system to test (if the remote unit supports multiple wireless traffic standards), a target phone number or URL, and whether the call is mobile or terrestrial originated.

160. It should be noted that the packet field types described above are for illustrative purposes and in no way limit the actual fields that may be used.

161. The information in the packet can be sent as either ASCII or binary data. ASCII is useful since some two-way data systems are used for paging and will only pass ASCII text information. Binary storage is useful because it is more bandwidth efficient than ASCII.



Furthermore, the packet information can be compressed by a variety of standard methods such as null compression, run-length compression, keyword encoding, adaptive Huffman coding, Lempel-Ziv coding, and the like. Additionally, the packet information can be encrypted by a variety of standard methods such as DES, triple DES, RSA, PGP, and the like.

162. In accordance with one embodiment of the invention, the packets are combined in larger files for transmission over the control link. This is advantageous in an environment in which the control network charges a fixed charge per packet. Accordingly, larger files may be more cost effective. Furthermore, it may be advantageous to store the collected information at the remote unit for transmission at a later time. This can occur if Layer 3 information is collected since the data may be collected faster than it can be sent over the control link. Additionally, the collected information may be stored at the remote unit if the vehicle ignition is turned off during a mission in a mobile environment. This occurs because the system tries to reduce transmissions when the ignition is off in order to extend battery life.

#### V. METHOD FOR MEASURING

163. FIG. 7a shows a method for measuring data quality of service in a wireless network in accordance with one embodiment of the invention. The method includes the steps of sending command information 702, performing measurements 704, and receiving response information 706.

164. For example, the step of sending command information 702 may include using a back end processor to send either data or signaling packets to the remote units of a measuring system such as the one described previously. Furthermore, the step of performing measurements 704 may include performing any of a variety of measurements such as latency of wireless Internet access, e-commerce transactions, wireless messaging, or push technologies. The step of receiving response information 706 may include responses to status inquiries or data related to the measurements collected during the step of performing measurements 704.

165. FIG. 7b shows a method for measuring data quality of service in a wireless network, including at least one step related to the wireless network infrastructure, in

accordance with a further embodiment of the invention. The method includes the sending 702, performing 704, and receiving 706 steps described with respect to FIG. 7a. Additionally, the method includes steps of monitoring a WAP Gateway 710 and Benchmarking at a WAP Gateway 712.

166. The step of monitoring the WAP Gateway 710 may include monitoring traffic through the WAP Gateway and providing metrics such as throughput, latency and lost packet information. Furthermore, the monitoring step 710 may allow the collection of protocol information directly from the WAP Gateway that may not be available to the multiple remote units. The step of benchmarking at the WAP Gateway 712 may allow latency measurements without including the uncertainties of the latency through the Internet or data network itself. This allows the provision of data indicating a breakdown between the latency of the wireless network and the data network.

167. It is important to note that in regard to steps 710 and 712 that the closeness to the WAP gateway is described from a logical, not a physical, standpoint. It will be appreciated by those of ordinary skill in the art that these process steps can be accomplished with well known techniques in which the monitoring or benchmarking element is located far away from the WAP gateway. Furthermore as previously discussed, the term WAP is being used generically to describe any type of wireless Internet protocol, including HDML, WAP competitors, and any future wireless Internet protocols that may be developed.

168. FIG. 7c shows a method for measuring data quality of service in a wireless network, including at least one additional order independent step, in accordance with another embodiment of the invention. The method includes the sending 702, performing 704, and receiving 706 steps described with respect to FIG. 7a. Additionally, the method includes steps of accessing from the Internet 720, scheduling missions 722, generating test traffic 724, storing at a remote unit 726, pre-processing at a remote unit 728, post-processing at the back end 730, and organizing remote unit information 732.

169. The step of accessing from the Internet 720 may include the ability to access the measuring system from the Internet through a portal to set up missions and retrieve reports generated from the post-processed data, for example. The step of scheduling missions 722

may include establishing parameters related to the specific data to be collected by the system. For example, these parameters may include some of the following: type of access – WAP, SMS, Instant Messaging, Push data, and the like.; type of Device – WAP, PDA, Pager, wireless modem, and the like.; trigger – time of call, location of remote unit, or some combination; wireless system – Sprint, Nextel, AT&T, and the like.; call Info – Target phone#, URL, type of transaction, etc; and mobile or terrestrial originated call. The step of generating test traffic 724 may include generation of SMS messages or other data packets to be sent to the remote units, for example.

170. The step of storing at the remote unit 726 may include the storing of missions and of collected data at the remote unit. The step of pre-processing at the remote unit 728 may include processing received data prior to storing the data or transmitting it to the back end processor. The step of post-processing at the back end 730 may involve processing of the received data for either RF/network parameters related to the wireless system or statistical information related to the wireless data access. The step of organizing remote unit information may include storage of remote unit identification information in a remote unit database, storage of collected data in a collected data database, or storage of post-processed data in a post-processed data database, for example.

171. It should be noted that the flow arrows in FIGS. 7a-7c are shown merely for illustrative purposes and do not reflect a required order for the method steps.

## **VI. OPERATIONAL AND BUSINESS MODEL**

172. The previous sections of this description have discussed a method and system for measuring data quality of service in a wireless network using multiple remote units and a back end processor. The method and system may also include an element that is located within the wireless network infrastructure, for example, at the WAP gateway to monitor the wireless data protocol and to perform benchmarking measurements.

173. In light of those previous sections, the following section discloses the operational and business model for the system in accordance with a further embodiment of the invention.

174. Rather than selling measurement equipment as a final product, the system, as defined by the invention, preferably sells the collected data and statistics generated from

the collected data as the final product. The trade name for this service is preferably "Bitwise." The data and statistics generated by the system do not need to be real-time, but as previously disclosed the system will support near real-time data if desired. Typically, the data will be collected and analyzed over a period of time such as a day, week, month, or even a year depending on the user's requirements.

175. The types of data collected include latency, call statistics (such as call completion, call dropped, etc), BER/FER, and various wireless network parameters such as RSSI and Layer 3 information. For example, the latency time is a measure of the access time for a WML page from a WAP server or the time to complete a Web transaction. Furthermore, the system can divide the latency measurement into the wired network and wireless network contribution through the use of a component located at the WAP gateway.

176. Furthermore, the remote units can be used to perform additional functions that have value in vertical markets. For example, if the remote units are fielded in a mobile environment in a fleet of vehicles, the remote units can provide automatic vehicle location (AVL) in addition to data quality of service measurements. Additionally, the position data from the mobile remote units could be processed to provide near real-time traffic information that could be disseminated, for example, over the Internet.

177. There are a variety of possible pricing strategies for the data and statistics produced by the system. The user may be charged per minute of system use or per transaction. Alternatively, the user may be charged per city, per wireless carrier, and per month for the requisite data and statistics. Furthermore, the post-processing element produces aggregate industry-wide statistics, for example comparing different wireless carriers or content providers, which is preferably packaged and sold as a separate product.

178. The customers for the system have a variety of common attributes. They are dot.com and e-commerce companies that are targeting wireless device users by porting their content and commerce to wireless web sites. Furthermore, they generally have a need for timely dissemination of content and transactions and have a keen interest in a positive customer experience.

179. The customers can be divided into a variety of different groups. They can be wireless operators who wish to measure the performance of their networks in order to

increase traffic and optimize performance. Furthermore, the customers can be wireless portals and/or ISPs such as AOL, Yahoo, Alta Vista, MSN, Lycos, and Excite, just to name a few examples. Additionally, the customers can be content providers in a variety of fields such as the service arena providing financial, weather, or traffic content; the internet auction arena involving time-sensitive bidding information; the instant messaging arena such as the AOL Anytime, Anywhere program; and the push data technology arena in which information such as airline information and traffic updates are pushed to the mobile device.

180. The reasons that customers would use the system, in accordance with an embodiment of the invention, are fairly straightforward. It allows the customer to see the wireless Internet transaction through the end user's eyes in terms of their experience when accessing content and conducting transactions from wireless devices. In addition, it allows the customers a method for evaluating and comparing the performance of the wireless networks that are delivering the content. Furthermore, it allows the wireless operators and the content providers solid data to pinpoint bottlenecks and performance problems in the network. Additionally, it provides information to alert staff to critical service failures so corrective action can be taken in a timely manner.

181. There are a variety of potential measurements that can be taken. Each measurement is referred to as a mission. Some examples of missions include retrieval of a WML page, completion of an e-commerce transaction, receiving pushed data content, performing a secure transaction, and performing benchmarking of different parts of the network by using a component located at the WAP gateway.

182. There are a variety of methods for inputting requested missions. If the customer wishes, they can discuss their requirements with the system operator and allow the system operator to enter the missions. Alternatively, a user interface in the back end processor allows the customers to enter their own missions over the Internet by entering through the portal.

183. The parameters for a mission may include at least the following items:

Type of access – WAP, SMS, Instant Messaging, Push data, and the like.

Type of Device – WAP, PDA, Pager, wireless modem, and the like.

Trigger – time of call, location of remote unit, or some combination  
Wireless System – Sprint, Nextel, AT&T, and the like.  
Call Info – Target phone#, URL, type of transaction, etc  
Mobile or Terr. Originated.

184. The output of the system can be obtained in a variety of ways. Generally, customers can set up formatted reports that will be generated periodically with the requested data and statistical information. The reports are obtainable in a variety of ways such as viewed using a Web browser, sent as an attachment to e-mail, sent as a file using FTP or some other protocol, or sent via normal mail just to name a few examples. The reports can be arranged in a variety of formats depending on the customer requirements with examples provided in the following figures.

185. FIG. 8a shows a bar graph output **810** of download times from different portals, in accordance with an embodiment of the invention. The y-axis of the bar graph relates to the average download time in seconds and the x-axis relates to the city in which the measurement was performed. The three bars represent measurements for Yahoo, AOL, and a portal index of measurements over all portals. The statistics shown are for all wireless carriers, with a measurement interval of 15 minutes between 6 AM and 12 PM, for the period from 03/01/00 to 03/07/00.

186. FIG. 8b shows a bar graph output **820** of download times across different wireless networks, in accordance with an embodiment of the invention. The y-axis of the bar graph relates to the average download time in seconds and the x-axis relates to the city in which the measurement was performed. The three bars represent measurements for Nextel, Sprint PCS, and AT&T Wireless. The statistics shown are for access to Yahoo, with a measurement interval of 30 minutes between 6 AM and 9 PM, for the period from 03/01/00 to 03/07/00.

187. FIG. 8c shows a bar graph output **830** of call completion percentage across different wireless networks, in accordance with an embodiment of the invention. The y-axis of the bar graph relates to the call completion percentage and the x-axis relates to the city in which the measurement was performed. The three bars represent measurements for Nextel, Sprint PCS, and AT&T Wireless. The statistics shown are for access to Yahoo,

with a measurement interval of 30 minutes between 6 AM and 9 PM, for the period from 03/01/00 to 03/07/00.

188. FIG. 8d shows a trending graph output **840** of call completion percentage across different wireless networks, in accordance with an embodiment of the invention. The y-axis of the bar graph relates to the call completion percentage and the x-axis relates to the city in which the measurement was performed. The three bars represent measurements for Nextel, Sprint PCS, and AT&T Wireless. The statistics shown are for access to Yahoo, with a measurement interval of 15 minutes between 6 AM and 9 PM, for the period from 03/01/00 to 03/07/00.

189. FIG. 8e shows a bar graph output **850** of average download times with a breakdown of the network latency at the WAP gateway, in accordance with an embodiment of the invention. The y-axis of the bar graph relates to the average download time in seconds and the x-axis relates to the city in which the measurement was performed. The bars represent measurements for Nextel with statistics shown for access to Yahoo, with a measurement interval of 60 minutes between 12 PM and 12 PM, for the period from 03/01/00 to 03/07/00.

190. FIG. 8f shows a pie chart **860** of error statistics for wireless access of Yahoo, in accordance with an embodiment of the invention. The sectors of the pie chart show DNS lookup failure, connection timeout, page timeout, content errors, and successful error-free connections. The statistics represent error statistics for all carriers with statistics shown for access to Yahoo, with a measurement interval of 60 minutes between 12 PM and 12 PM, for the period from 03/01/00 to 03/07/00.

## VII. EXEMPLARY EMBODIMENT

191. Referring to FIG. 9, a system according to an exemplary embodiment of the present invention has two major components: Remote units (a.k.a. PUPPIs) **910, 920** which perform measurements related to Internet content delivery over wireless networks, and a Back End **930** that controls the remote units **910, 920** and performs data collection and storage.

192. The basic control of the PUPPI **910** consists of commands sent from the Back End **930** to the PUPPI **910** and responses sent from the PUPPI **910** to the Back End **930**. The

commands are generally missions that direct the PUPPI **910** to collect data from a particular wireless content provider within a particular time period. The responses are generally the results of these collection missions. The PUPPI's physical interface to the control link **950** is a modem **912** that allows communication over a communication link **940**, such as the PSTN, or over a data network, such as the Internet. The control link **950** can be implemented in a wired configuration, as shown in FIG. 9, or in wireless configuration using a wireless modem.

193. The PUPPI's physical device for performing wireless measurements generally is a standard handset **914** that is connected to the PUPPI control unit via a serial cable. However, any wireless device such as a wireless modem module, PDA, RIM device, pager, etc can be used depending on the wireless network to be tested. Additionally, the software module with the appropriate WDP will be selected based on the wireless network to be tested.

194. Referring to FIG. 10, the remote units (PUPPIs) in the exemplary system include a control unit **916** for controlling the remote unit, a test traffic modem **914** for performing measurements over the wireless network, and a control link modem **912** for passing commands and responses between the remote unit **910** and the back end processor **930** (refer to FIG. 9).

195. The control unit **916** may be implemented as a PC, a laptop, a handheld computer, or an embedded computer, to name but a few examples. The test traffic modem **914** may be implemented as a standard handset or a modem module, either of which should include an external antenna. The control link modem **912** may be implemented as a standard POTS modem (using a dedicated phone line), a DSL modem, ISDN modem, or an equivalent system.

196. The internal hardware interface for the PUPPI is embodied as an RS-232 serial connection between the control unit **916** and the test traffic modem **914** (generally a handset). Alternatively, the connection can be implemented using a USB port, Firewire port, PCMCIA, or any other appropriate interface for the test traffic modem. The internal hardware interface between the control unit **916** and the control link modem **912** will depend upon the control link modem selected. If a standard V.90 modem (56.6 kbit/s) is



used, then it can be housed inside the control unit case and plugged in to the PCI system bus or connected via an Ethernet connection over a LAN. If a DSL modem (or other advanced data modem) is used, then it will be connected to the control unit with an appropriate interface. If a wireless link control modem **912** is used, it will communicate with the control unit **916** via an appropriate interface, such as a serial port.

197. The PUPPIs in the exemplary system are stationary indoor units or mobile units, including an external wireless antenna, under remote control from the back end using a special scripting language.

198. The PUPPI is designed to simulate a subscriber using a WAP enabled handset or any WDP-enabled wireless device. WAP handsets have mini-browsers loaded onto the handset to allow this functionality. Because of limitations on the ability to control and track data on the handset itself, the exemplary remote unit may move the web browsing functionality from the handset to the control unit, where full browser control and data tracking is possible. In this case, the handset will be used for a dial-up networking connection which will provide access to the wireless data network, and will allow packets to flow between the WAP browser on the control unit and the WAP gateway at the operator's switch via the handset.

199. The PUPPI software includes three main processes, a test process, a control process, and a logging process. The test process is responsible for all aspects of measurement. The control process is responsible for all communications with the Back End system. The logging process is responsible for logging all events from each process and generating alarms.

200. Referring to FIG. 11, processes are illustrated that each contain software modules that are responsible for specific tasks.

201. The Main Control Module (MCM) **1104** is responsible for all management and control of the PUPPI unit. Some of the functions that the MCM is responsible for are listed as follows:

- Tasking Modules with Measurements
- Handling Timing Issues
- Starting and Stopping Measurements
- Responding to Diagnostics Requests

- Receiving Task Lists
- Sending Collected Data

202. The test link connection module (TLCM) **1108** manages the test link connection. The test link connection is used by the data modules to collect information from the wireless data network. The test link connection includes of a dial-up networking connection to support modules requiring wireless data, and a direct handset connection for modules requiring transport information.

203. The GPS module (GPSM) **1112** can optionally be included to provide GPS information to the Main Control Module. For example, the time information provided by the GPS Module can be used by the MCM to provide very accurate time stamps for the collected data. Furthermore, in a mobile environment the location information from the GPS Module can be used to provide position information. The term GPS is being used generically to refer to any type of position location technology including a distributed GPS (e.g. SnapTracks) and Time Difference of Arrival or Time Angle of Arrival (e.g. TruePosition). These additional forms of location determination may include the addition of a location server to the system.

204. The WAP/WML data module (WDM) **1116** is responsible for performing all WAP related tasks. Embedded within the module will be WAP browser capabilities. The WDM is responsible for handling all WAP gateway login requests and security key exchanges. As previously discussed, the exemplary embodiment can include a WDM to collect data on any WDP, depending on the network that is being tested.

205. The transport data module (TDM) **1120** is responsible for collecting all transport related data such as signal strength, quality, etc. This module is designed to be transport specific, and is loaded based on the transport technology being used (i.e. CDMA, iDEN, TDMA, GSM, etc.) Because data is collected differently for each transport technology, the module may be run in parallel with other modules (e.g. iDEN) or may need to be run serially while other modules are not collecting data (e.g. CDMA).

206. The SMS module (SMSM) **1124** is responsible for collecting SMS information related to a specific wireless network. For example, the SMS message can be either transmitted or received by the module. The SMS module is able to track the difference

between the time of SMS transmission and reception in order to determine the latency in the system.

207. The PDA module (PDAM) **1128** is responsible for collecting information related to PDA access of data via a wireless network. The possible PDAs to be used can include, but are not limited to, Palm, Pocket PC, Handspring, RIM, etc.

208. The Push Notification Module (PNM) **1132** is responsible for collecting information related to data that is pushed via a wireless network to the remote device. For example, the Phone.com gateway includes a utility for pushing data to the remote device using WAP. There are a variety of other ways in which data can be pushed to the remote device.

209. The Passive Monitoring Module (PMM) **1136** will be responsible for collecting information related to passive monitoring of a wireless network. This differs from the latency measurement function because there is no need for the process to generate any information (i.e. it only needs to monitor and passively receive information). For example, the PMM listens to the control channel and collects Layer 3 information.

210. The Wireless Web Data Module (WWDM) **1140** will be responsible for performing tasks related to the chosen wireless web standard. This module is similar to the WAP/WML module but is used in networks in which other wireless web protocols (such as HDML, i-MODE, etc.) are used rather than WML. These protocols are generically referred to as WDP (Wireless Data Protocol).

211. The HTML Data Module (HTDM) **1144** is responsible for performing HTML tasks. This module is similar to the WAP/WML module but is used in networks in which HTML is used rather than WML.

212. The E-Mail Data Module (EDM) **1148** is responsible for performing e-mail tasks. This includes the ability to both transmit and receive e-mails at the remote device over the wireless network.

213. The FTP Data Module (FDM) **1152** is responsible for performing FTP tasks that involve the transmission of files. Although this module is referred as FTP (based on the TCP/IP file transmission protocol) this module will be able to implement a variety of file

transmission protocols including future protocols which may be developed to move files over wireless networks.

214. The Packet Sniffing Module (PSM) **1156** is responsible for performing packet sniffing tasks. This includes the ability to decode and log low level packet information similar to the functionality on a LAN packet sniffer.

215. The Multimedia Data Module (MMDM) **1160** is responsible for performing tasks related to the transmission or reception of various types of multimedia data. For example, the multimedia data could be music files such as MP3 compressed music or some form of streaming video using a variety of different compression standards.

216. The Status Module (StatM) **1164** is responsible for providing status information related to the remote unit. This is accomplished in any of a variety of alternative ways. For example, the Status Module can be responsible for providing periodic "heartbeats" which are monitored by the Back End to ensure that the remote unit is still alive and well. These heartbeats may be embodied a simple message which just states the unit is alive, or they may be embodied as more sophisticated messages including status information such as the available memory, amount of memory used, current configuration, temperature, etc. As another alternative, the system may be embodied with the Back End polling the remote units and the Status Module responding to the requests. In a further alternative, the system may include both heartbeats and polled status responses.

217. The optional control link connection module (CLCM) **1168** manages (if implemented) the control link connection. The control link connection is used by the PUPPI unit to send and receive messages from the back end software. This module is optional and may be left out in implementations that use a higher level protocol to maintain the link between the remote units and the back end. For example, if the remote units run a database with setup info and collected data, the back end can communicate with the remote units by simply accessing their individual databases using remote database communications.

218. Each data module logs collected information to a local database via the logging module (LM) **1172**. This module handles data logging requests from each module.

219. The alarm module (AM) 1176 allows the setting of alarm conditions and produce alarms if an alarm condition is reached. For example, if data is being stored at the remote unit, an alarm condition may be set if the on-board storage is more than 80% full in order to prevent a storage overflow from occurring.
220. Each software module has a defined method of communicating with the PUPPI Main Control Module (MCM) 1104. The MCM 1104 has the ability to send requests to each module and receive responses. MCM 1104 requests may include status checks, tasks, etc. Each module will communicate with the logging module (LM) 1172 to log results.
221. The WAP Data Module (WDM) 1116 communicates with the WAP Gateway using UDP. The Control Link Module (CLM) 1168 communicates with the back end server using TCP/IP.
222. The exemplary system has remote control capability. A remote access application (e.g., PC Anywhere or an equivalent thereof) is loaded onto each PUPPI unit to allow full remote access to the PUPPI unit. This software is configured to automatically execute and enter a host mode when the machine is started. While running, the application remains in host mode, waiting for connections from external machines.
223. The exemplary system also has application protection capabilities. Each PUPPI unit may include a special hardware card that can be used to force a machine reboot if software problems are encountered. The Main Control Module (MCM) 1104 will be tasked with monitoring each process to verify that each is running properly. If any process does not respond to the MCM's request within a predefined period of time, the hardware card will automatically reboot the machine.
224. For a stationary PUPPI in a controlled environment, an exemplary PUPPI control unit is advantageously implemented as a standard rack mounted PC. For a mobile PUPPI, there are a variety of possible embodiments depending on the operating environment. The PUPPI hardware can include a separate enclosure for shielding the handset from the PC. The handset enclosure includes access for a serial cable for control purposes and a port for an external antenna.

225. In the event that multiple technologies are required at a remote location, a variety of options are available to implement them. For example, a single PUPPI unit with multiple serial ports can be set up to implement multiple technologies. The only limit to this approach is the processing power and storage capacity of the PUPPI to support multiple technologies. Alternatively, each PUPPI can support a single technology and be connected via a LAN with the ability to communicate with the Back End.

226. Referring to FIG. 12, for example, a router **1200** is used as the interface between an external communication line **1210** (such as a DSL or dialup line) and a LAN **1220** that is connected to the PUPPIs **1230**.

227. In FIG. 13, the basic architecture for the Back End according to the exemplary embodiment is illustrated.

228. The Back End performs the following major functions:

- Performing fleet management of the PUPPIs to include sending commands and receiving responses using the control link, and performing queuing of missions based on measurement scripts
- Maintaining a database of PUPPI information
- Maintaining a database of requested and scheduled collection missions
- Maintaining a database of collected data
- Providing a user interface for entering collection mission tasking and extracting collected data

229. The user interface **1310** to the system is a simple interface that allows users to prepare test scripts over the Internet **1320** to collect data, and to extract the collected data. The other major component of the Back End provides Fleet Management and Data Management for the PUPPI fleet **1330**, the scheduled missions **1340**, and the collected data **1350**.

230. The Back End is implemented using commercial-grade PCs and standard software and database tools.

231. The back end software preferably includes a fleet manager application, a centralized database server, and a web server. The fleet manager software allows the system operator to do the following:

- Define measurement
- Assign measurements to PUPPIs

- Query PUPPIs for diagnostic information
- Start and stop PUPPI measurements
- Query PUPPIs for configuration information
- Schedule delivery of measurements
- Query PUPPIs for measurement results

232. All data collected from the PUPPIs is stored on a centralized database server. The database contains detailed information about the measurements, assignments, configuration information, etc. The data to be collected by the system is entered through a scripting language.

233. Referring to FIG. 14, two basic software modules included in the Back End are illustrated. The modules, the Queue Builder Module **1410** and the Scheduler Module **1420**, convert the mission requests from the script to an actual mission to be executed on the PUPPI.

234. The Queue Builder Module **1410** takes the information from the script and converts it to a queue of data collection missions for the PUPPIs. The scheduler **1420** takes the information in the queue and converts it to a list of tasks at regular intervals (e.g. daily) that are sent to the PUPPIs and then executed. The resulting data is extracted from the PUPPI database **1430** after it is collected.

235. Referring to FIG. 15, hardware architecture for the Back End according to the exemplary embodiment is illustrated. The Back End hardware includes, at a minimum, a scalable configuration of commercial servers **1510**, **1520**, **1530** that support 24/7 operations. By design, significantly less data flows between a WAP client and server than between an Internet client and server. Many of the tasks handled by an Internet client (e.g. DNS lookup request and response) have been moved from the client to the server (or gateway) under WAP. Additionally, WAP-based WML pages differ from Internet based HTML pages. WML pages introduce the concept of decks and cards. WML pages contain decks that may have one or many cards. Each card is similar to a single page or screen view. A deck usually contains a collection of cards. When a user requests a URL from a WAP device, many times a deck with several cards is downloaded to the browser. Once the entire deck is downloaded, the user can move between screens without requesting that new content be downloaded from the server.

236. The exemplary system is configured to collect information that is specific to WAP-based browsing. The following metrics can be collected by the exemplary system. Web download would involve simulating a user downloading a single web page. Listed below is an example of the type of information that is collectable.

- **GET Time & Date**  
The time and date that the browser issued a GET command requesting a URL.
- **URL Address**  
Address of the URL being retrieved.
- **Deck Text Size**  
The size in bytes of the text portion of the deck and all associated cards.
- **Image Count**  
A count of the number of images embedded in a deck.

237. For each image, the following information may be collected:

- **Image Size**  
The size in bytes of the image.
- **Image Time**  
The time to download the image.
- **Image URL**  
The URL of the image.
- **Total Deck Time**  
The amount of time required to download the entire deck and associated images.
- **Total Deck Bytes**  
The total number of bytes within the deck (text and images)
- **Result**  
Whether the web download was successful or not.

238. Web navigation measurements involve simulating a user navigating to a page other than the page defined by the main URL. For example, a customer may desire to know how long it takes to navigate to the financial news section on the Bloomberg site.

239. All of the information listed in the Web Download section can be collected for each deck that was downloaded as part of the navigation task. Additionally, the information listed below may also be collected pending a technical assessment by Invertix.

- **Total Cards**  
The total number of cards (or screens) to reach final destination.



- **Total Decks**  
The total number of decks that had to be downloaded to reach final destination.
- **Total Navigation Time**  
The amount of time required to navigate to the final destination.
- **Total Navigation Bytes**  
The total number of bytes downloaded to navigate to the final destination.
- **Result**  
Whether the web navigation was successful or not.

240. Web transactions generally involve components of the Web Download and Web Navigation methods. Web transactions are defined as any action that requires the user to input information to obtain some result. Some examples would include inputting one's zip code to retrieve the weather, inputting a ticker symbol to retrieve a stock quote; or inputting one's billing information to purchase a book. Web transactions would collect all of the metrics included above for Web Download and Web Navigation. Additionally, the information listed below may also be collected.

- **Time for Response**  
Time for the network to respond to a user's input.
- **Result**  
Whether the user input was accepted / successful or not.

241. A full web transaction may require that a user input information on multiple screens. Metrics for each user input and response would be collected. The success or failure of a transaction would be based on the data that is returned in response to the request.

### **VIII. Data Mining Functionality**

242. The disclosure thus far has emphasized the collection and storage of the data. However, the issue of handling the data in a manner that adds value to the end customer is valuable and adds to the economic viability of the system. The collected data can be warehoused and mined to produce added value.

243. Telecom service providers (wireless carriers, ISPs, CLECs, ILECs, Satellite, and IXCs) can build wireless data portals and integrate their back office stove-pipe data systems into a single data warehouse platform. In addition, telecom operators may build and operate wireless portals to make billing and other customer care data available to

subscribers through an interactive, customizable Web and/or wireless data interface.

244. A data translation application is configured to collect data from various vendor-independent business areas (billing, customer care, marketing, network performance, etc.) and host it in a single data warehouse with specific vertical dimensional partitions. The data warehouse's data mode is configured to facilitate and speed up reporting.

245. According to a preferred embodiment, data mining is implemented (for example, using MicroStrategy's Intelligent E-Business Platform) so as to allow end users to use a graphical front-end web-based interface to perform analytical online queries on the underlying data and create reports tailored to specific needs. Report details range from a high-level management report where users can drill down and across to atomic-level data.

246. Tools enable advanced call center management applications to do the following:

- Increase employee productivity and reduce response times through detailed analysis of call volumes and patterns,
- Improve call center effectiveness by reporting on trouble ticket resolution,
- Make information available to the marketing staff for the development of customer campaigns, and
- Increase customer loyalty by keeping them informed through personalized messaging about network performance and problem resolution.

247. Effective marketing is critical for retaining customers as well as for acquiring new ones. Ensuring that customers have the optimal plan for their usage habits helps to boost revenue and reduce churn by enabling managers to plan marketing strategy to create new product offerings, analyze pricing, and assess the profitability impact of new offerings.

248. A portal provides subscribers with a single point of access to information for data, analysis and dissemination. As a personalized web-based gateway to information, it allows users to subscribe to key information, personalize it for their needs, and specify the desired frequency for its delivery, all through a single web-based interface. As one example, such functionality is powered by MicroStrategy InfoCenter. The portal is designed for large-scale deployments and includes an asynchronous update server, a high-speed interface cache, and clustering to meet the needs of large-scale implementations. Adaptable to many user requirements, the Telco Portal can provide the Telco Operator with the ability for its internal community to:

- analyze costs and revenues,
- adapt pricing and promotions maintain quality of service,
- improve sales and customer service,
- optimize customer loyalty programs, and
- reduce churn.

249. A portal also provides network operations and performance personnel with a powerful reporting tool that maps counties and trunk traffic activities. Daily, weekly, and monthly reports are automatically generated and pushed to appropriate personnel. Users can set rules for alerts and have messages sent to their mobile devices based on certain criteria triggers. Such functionality is advantageously powered by MicroStrategy Broadcaster.

#### **IX. Combination of Diverse Systems**

250. The system is described as a stand-alone system in the explication of the embodiments above. However, in accordance with a further embodiment of the invention, the system is combined with one or more secondary data collection systems.

251. One such secondary data collection system functions to collect some of the same data as gathered by a system according to the exemplary embodiment, above. This secondary system collects that data and sends it to a system according to the exemplary embodiment for processing.

252. Another such secondary data collection system functions to collect data that is different than the data collected by the exemplary system. The data from the secondary system and the exemplary system are be combined, either pre- or post-processing, in order to produce value-added reports for customers.

253. According to an alternative embodiment, a system embodied according to the present invention collects additional data (beyond the standard data types discussed above) that is then exported for use by the secondary system, either pre- or post-processing.

254. Additionally, it is noted that a back end installation according to the present invention is not limited only to the control of remote measurement units. The back end portion of a system according to the present invention is useful for providing scheduling, control, and data gathering for a variety of other system (for example, data collecting

sensors, telecommunications network operation centers for either wired or wireless systems, telecommunication QOS network operation centers, surveillance and security systems, automated adjustment of wireless network base station parameters, etc.).

255. A third implementation paradigm is also appropriate in the case of networks that already have well established back end operations. As opposed to the stand-alone and master controller paradigms discussed above, a back end according to the present invention may be implemented as an added set of functionalities as a part of an already existing network back end installation. Any additional hardware needed to implement the functions of the present invention's back end are simply integrated into those of an existing system, with the existing system being re-programmed to provide services as described above.

256. The present invention has been described in accordance with a number of preferred embodiments. However, it will be understood by those of ordinary skill in the art that various modifications and improvements may be made to the invention as described, without departing from the scope of the invention. The scope of the invention is limited only by the appended claims.

## WHAT IS CLAIMED IS:

1. A measuring system for measuring data quality of service on at least one traffic wireless network, comprising:

a plurality of remote units for performing measurements on the at least one traffic wireless network, each of the plurality of remote units implementing a Wireless Data Protocol (WDP) client, each of the plurality of remote units comprising:

at least one test traffic modem adapted to connect to one or more of the at least one traffic wireless networks,

a control link modem, and

a control unit coupled to the test traffic modem and to the control link modem;

and

a back end processor for remotely controlling the plurality of remote units, the back end processor being in communication with each of the plurality of remote units via a control link and exchanging commands and responses with the control link modem via the control link;

wherein selected ones of the plurality of remote units simulate operation of a WDP enabled wireless device by having the WDP client access the at least one traffic wireless network via the test traffic modem.

2. The measuring system of claim 1, wherein the test traffic modem comprises a wireless handset.

3. The measuring system of claim 1, wherein the test traffic modem comprises a wireless modem module.

4. The measuring system of claim 1, wherein the control link modem comprises a POTS modem, and the control link comprises a dedicated phone line.

5. The measuring system of claim 1, wherein the control link modem comprises a DSL modem, and the control link comprises a DSL line.

6. The measuring system of claim 1, wherein the control link modem comprises an ISDN modem, and the control link comprises an ISDN line.

7. The measuring system of claim 1, wherein the WDP client is implemented in the control unit.
8. The measuring system of claim 1, wherein the WDP client is implemented in the test traffic modem.
9. The measuring system of claim 1, wherein the WDP client comprises a WAP browser.
10. The measuring system of claim 1, wherein the WDP client comprises an iMode browser.
11. The measuring system of claim 1, wherein the remote unit simulates a subscriber using the WDP enabled wireless device.
12. The measuring system of claim 1, wherein one or more of the remote units includes a transport data module (TDM) that collects transport related data.
13. The measuring system of claim 1, wherein one or more of the remote units includes a Short Message Service (SMS) module that collects SMS information.
14. The measuring system of claim 1, wherein one or more of the remote units includes a Personal Digital Assistant (PDA) module that collects PDA information.
15. The measuring system of claim 1, wherein one or more of the remote units includes a Push Notification Module (PNM) that collects information related to data that is pushed.
16. The measuring system of claim 1, wherein one or more of the remote units includes a Passive Monitoring Module (PMM) that collects information related to passive monitoring of the at least one traffic wireless network.
17. The measuring system of claim 1, wherein one or more of the remote units includes an HTML Data Module that collects information related to HTML.
18. The measuring system of claim 1, wherein one or more of the remote units

includes a Packet Sniffing Module (PSM) that performs packet sniffing.

19. The measuring system of claim 1, wherein one or more of the remote units includes a Multimedia Data Module (MMDM) that performs tasks related to multimedia data.

20. The measuring system of claim 1, wherein one or more of the remote units includes a database providing storage for the measurements.

21. The measuring system of claim 1, wherein the back end processor includes a database providing storage for the measurements.

22. The measuring system of claim 1, wherein the back end processor includes a scheduler module that schedules the measurements.

23. The measuring system of claim 1, wherein the back end processor includes a data mining module that analyzes the measurements.

24. The measuring system of claim 1, wherein one or more of the remote units is stationary.

25. The measuring system of claim 1, wherein one or more of the remote units is mobile.

26. The measuring system of claim 1, wherein the back end processor is implemented in a stand-alone configuration.

27. The measuring system of claim 1, wherein the back end processor is implemented so as to provide command and control of diverse systems beyond the measuring system.

28. The measuring system of claim 1, wherein the back end processor is implemented so as to gather test data from one or more secondary systems distinct from the remote units.

29. The measuring system of claim 1, wherein the back end processor is

implemented by adapting a pre-existing back end installation to incorporate a set of added functionalities.

**30.** A measuring system for measuring data quality of service on at least one traffic wireless network, comprising:

- a back end processor for controlling the measuring system;
- a plurality of remote units, in communication with said back end processor via a control link, for performing measurements on the at least one traffic wireless network, each of the plurality of remote units comprising:
  - a test traffic modem adapted to connect to one or more of the at least one traffic wireless networks, the test traffic modem being selected from the group consisting of: a wireless handset and a wireless modem module,
  - a control link modem for exchanging commands and responses with the back end processor via the control link, and
  - a control unit coupled to the test traffic modem and to the control link modem, wherein a Wireless Application Protocol (WAP) browser is implemented via the control unit or the test traffic modem;
- wherein the remote unit simulates a subscriber using a WAP-enabled wireless device by having the WAP browser access the at least one traffic wireless network via the test traffic modem.

**31.** A remote unit for measuring data quality of service on at least one traffic wireless network, the remote unit for operating under the control of a back end processor, the remote unit comprising:

- a test traffic modem adapted to connect to one or more of the at least one traffic wireless networks;
- a control link modem in communication with the back end processor via a control link; and
- a control unit coupled to the test traffic modem and to the control link modem;
- wherein the remote unit implements a Wireless Data Protocol (WDP) client and performs data quality of service measurements on the at least one traffic wireless network by simulating operation of a WDP enabled wireless device by causing the WDP client to



access the at least one traffic wireless network via the test traffic modem.

32. A back end processor for measuring data quality of service on at least one traffic wireless network by controlling a plurality of remote units that gather data, each of the plurality of remote units implementing a Wireless Data Protocol (WDP) client, the back end processor comprising:

- a fleet database providing storage of information concerning the plurality of remote units;

- mission schedule database providing storage of information concerning measurement missions to be carried out by the plurality of remote units; and

- a fleet management server in communication with each of the plurality of remote units via respective control links and adapted to exchange commands and responses with selected ones of the plurality of remote units, the fleet management server effecting communication with the remote units based on information accessed from the fleet database, the commands being based on information accessed from the mission schedule database;

wherein the fleet management server commands certain of the plurality of remote units to simulate operation of a WDP enabled wireless device by having the WDP client access the at least one traffic wireless network.

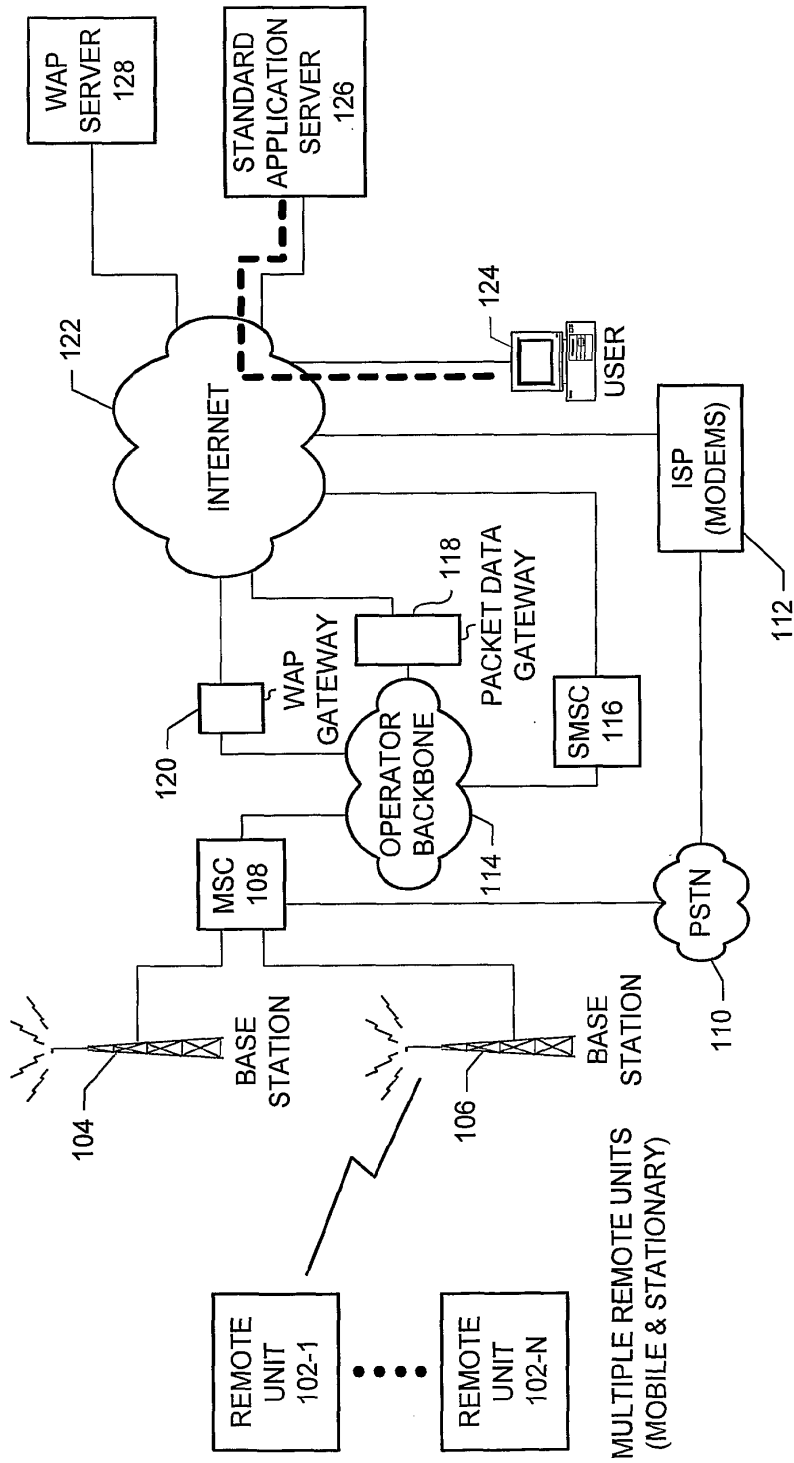


FIG. 1a

SUBSTITUTE SHEET (RULE 26)

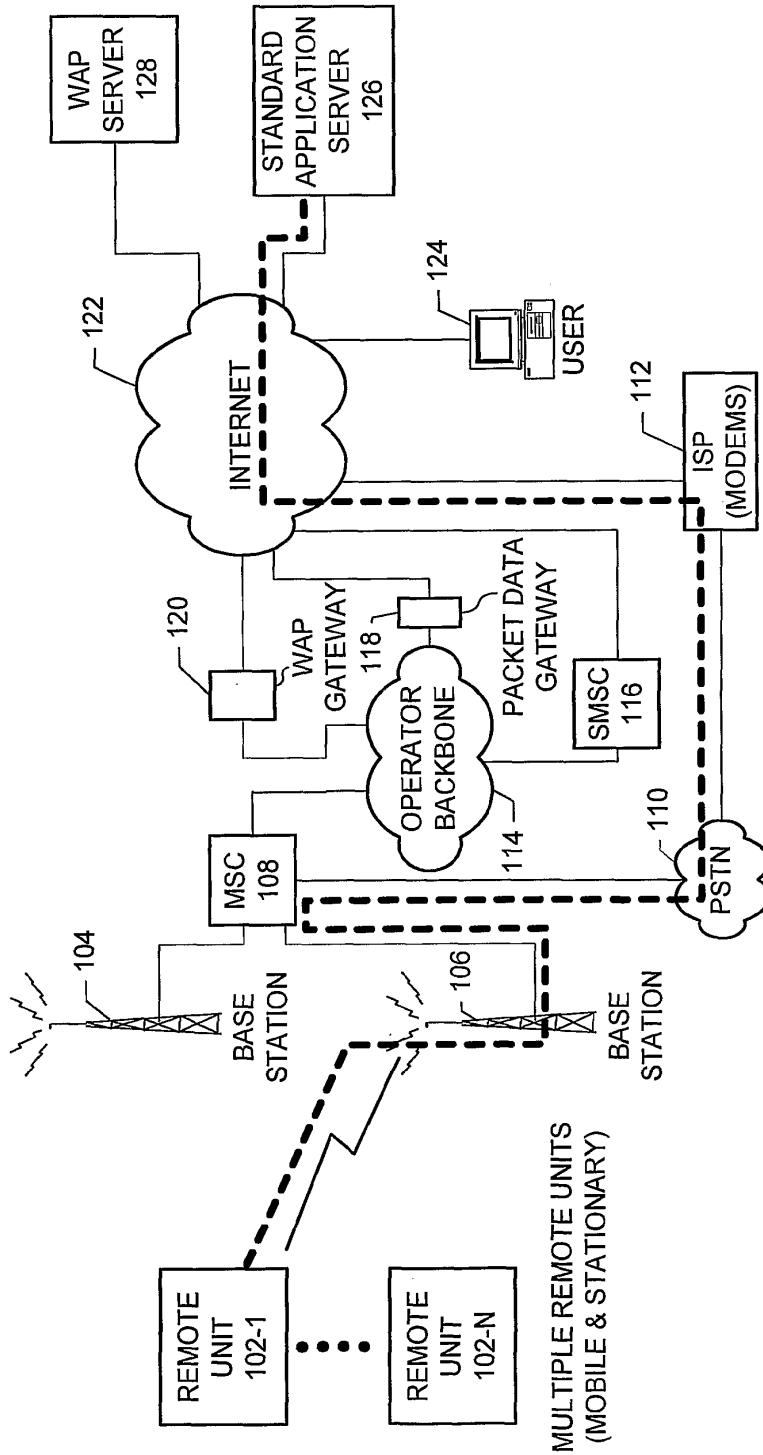


FIG. 1b

SUBSTITUTE SHEET (RULE 26)

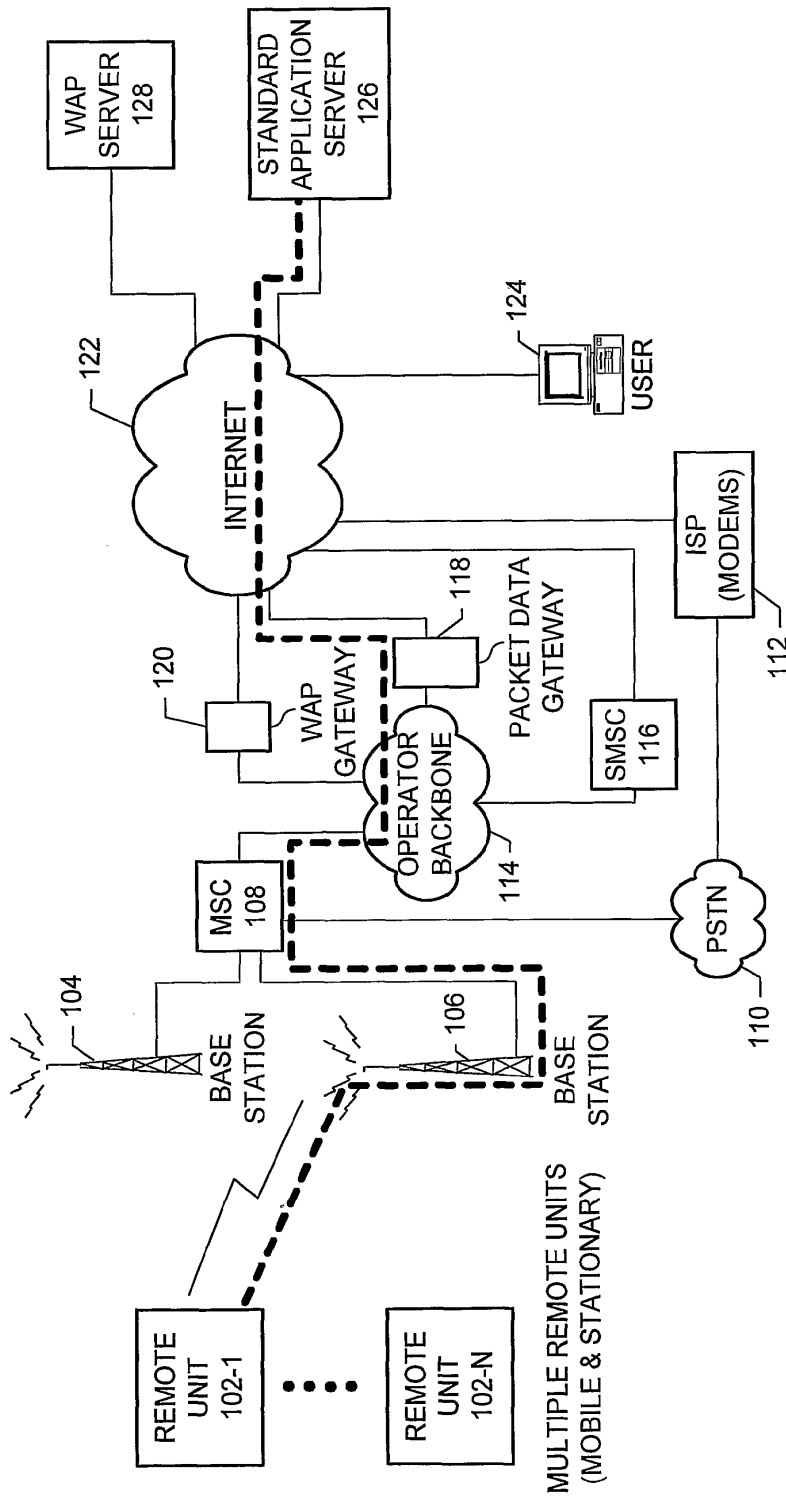


FIG. 1c

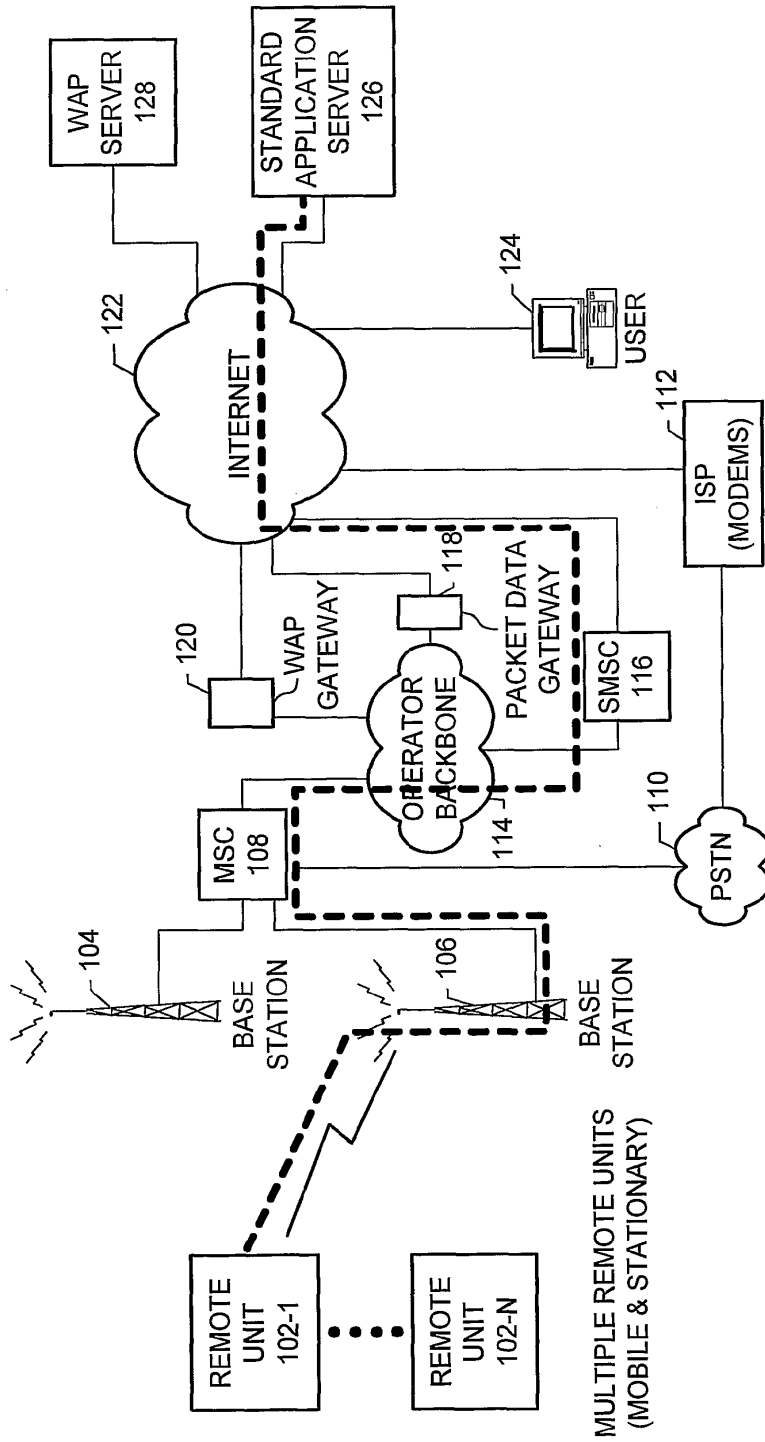


FIG. 1d

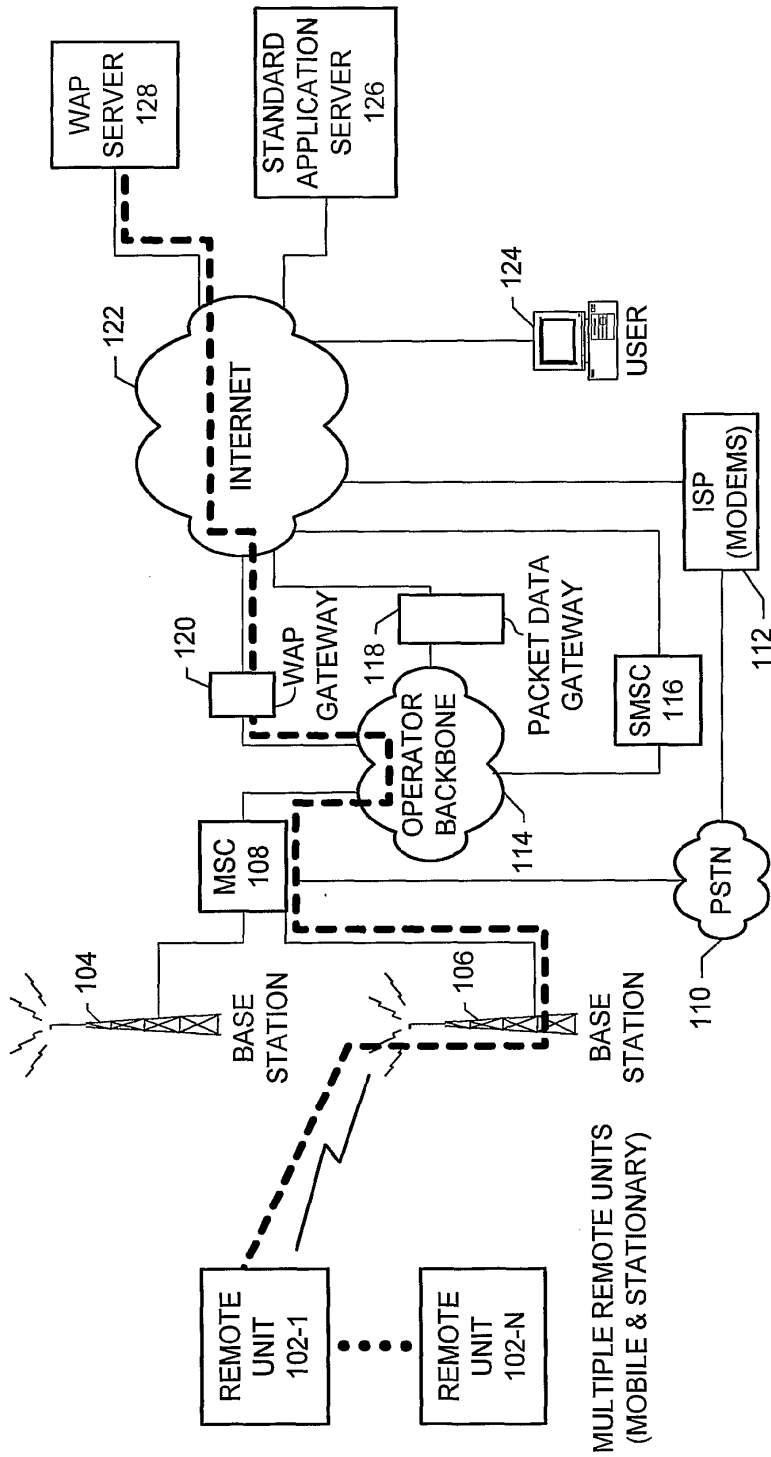


FIG. 1e

SUBSTITUTE SHEET (RULE 26)

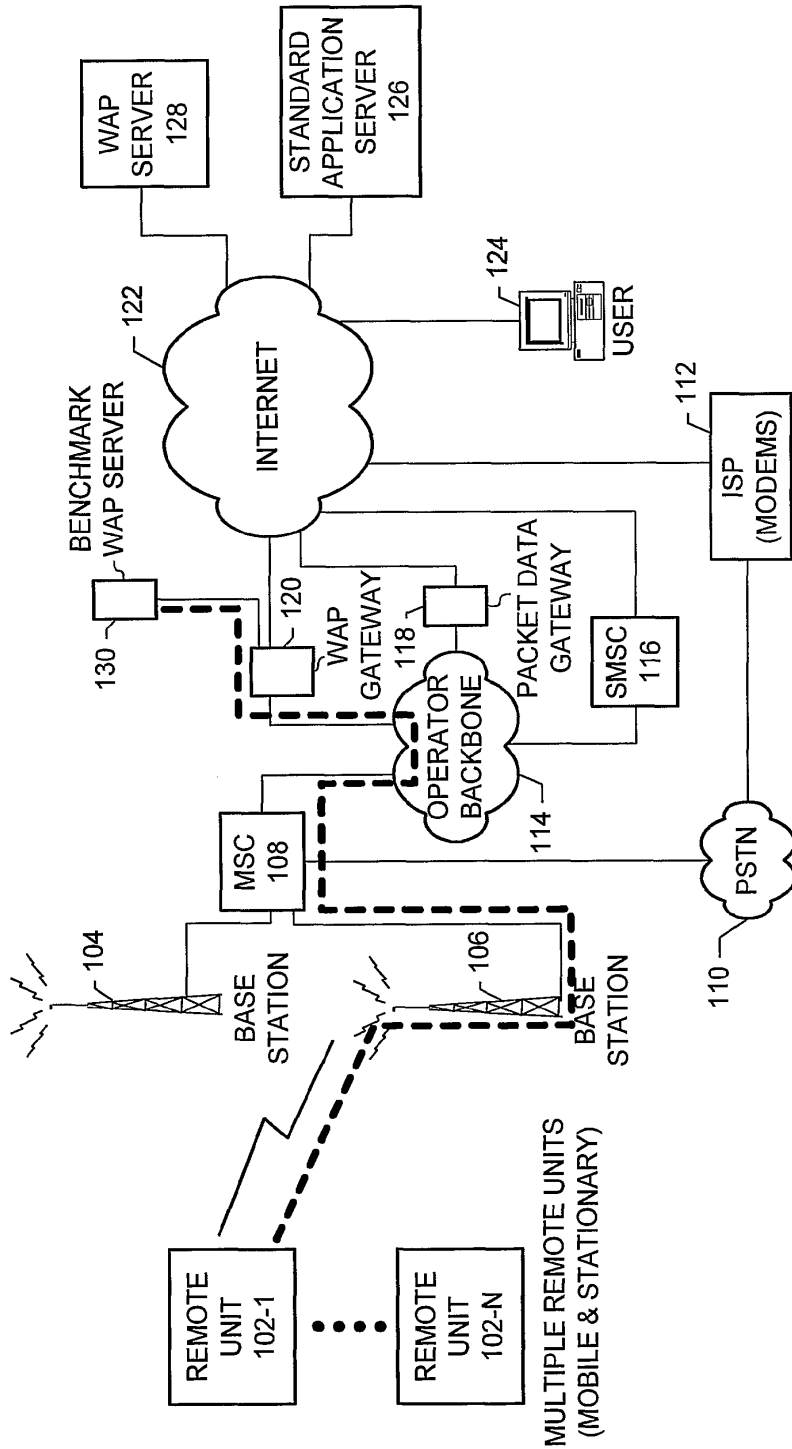


FIG. 1f

SUBSTITUTE SHEET (RULE 26)

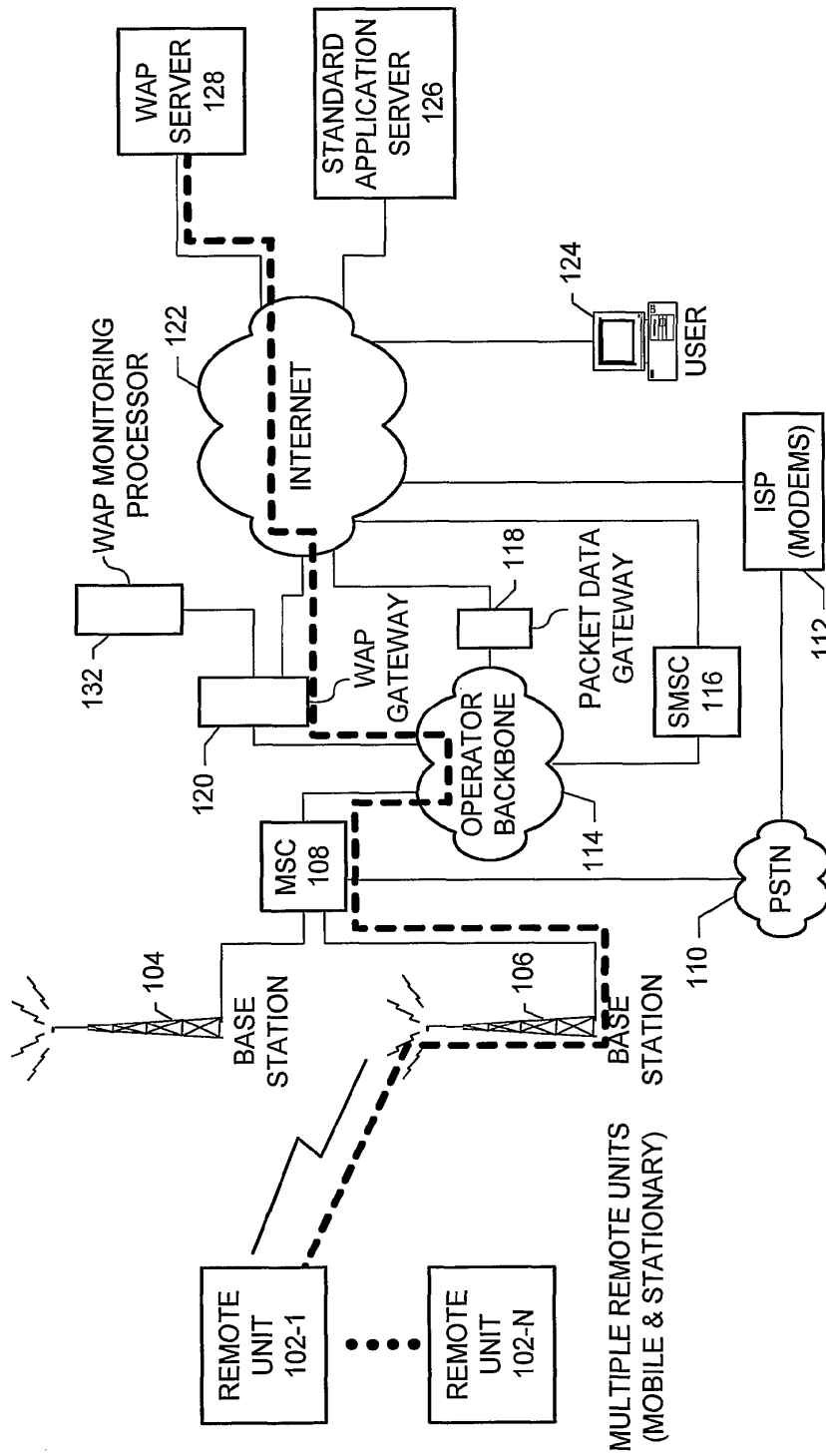


FIG. 1g

SUBSTITUTE SHEET (RULE 26)



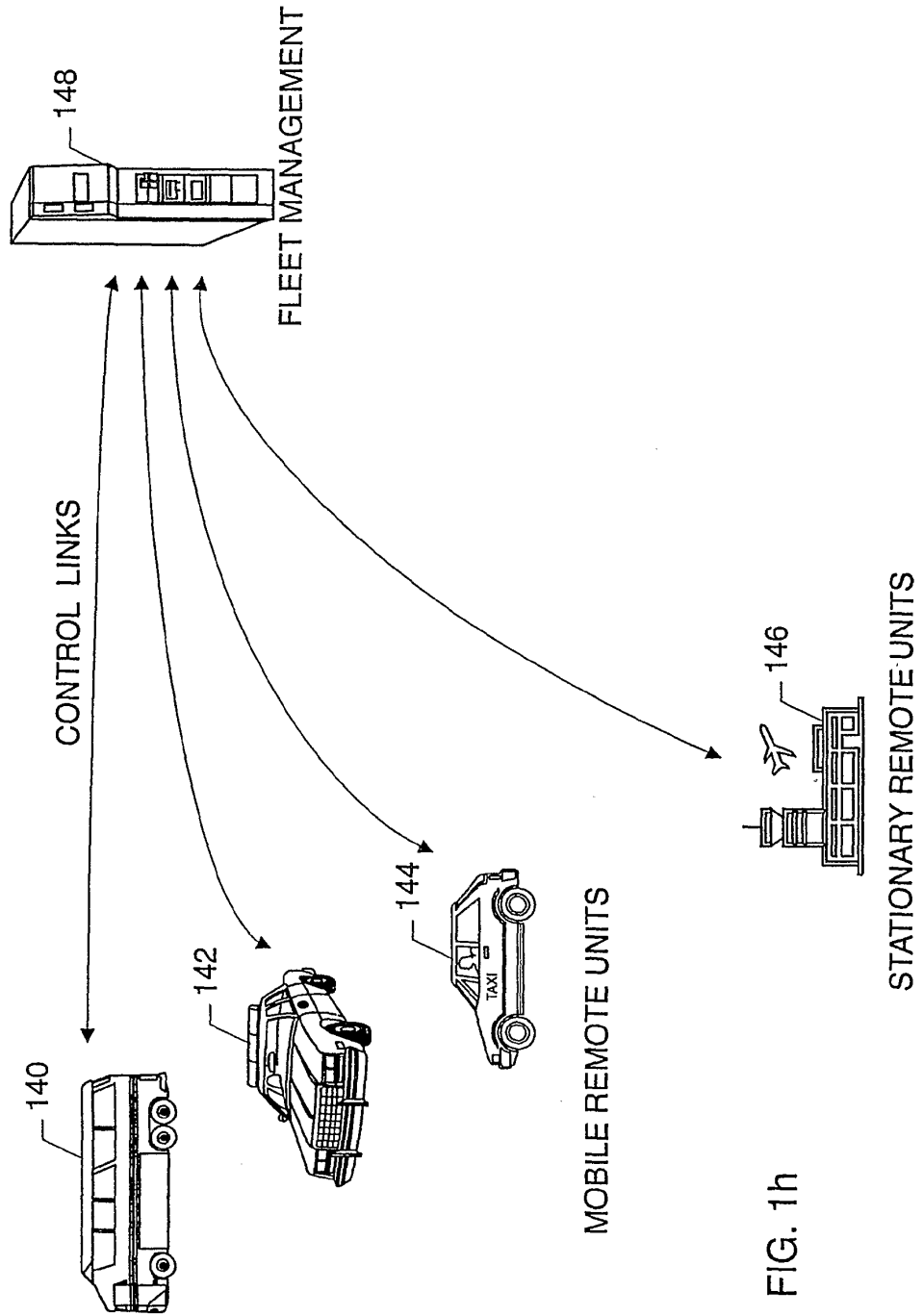


FIG. 1h

SUBSTITUTE SHEET (RULE 26)

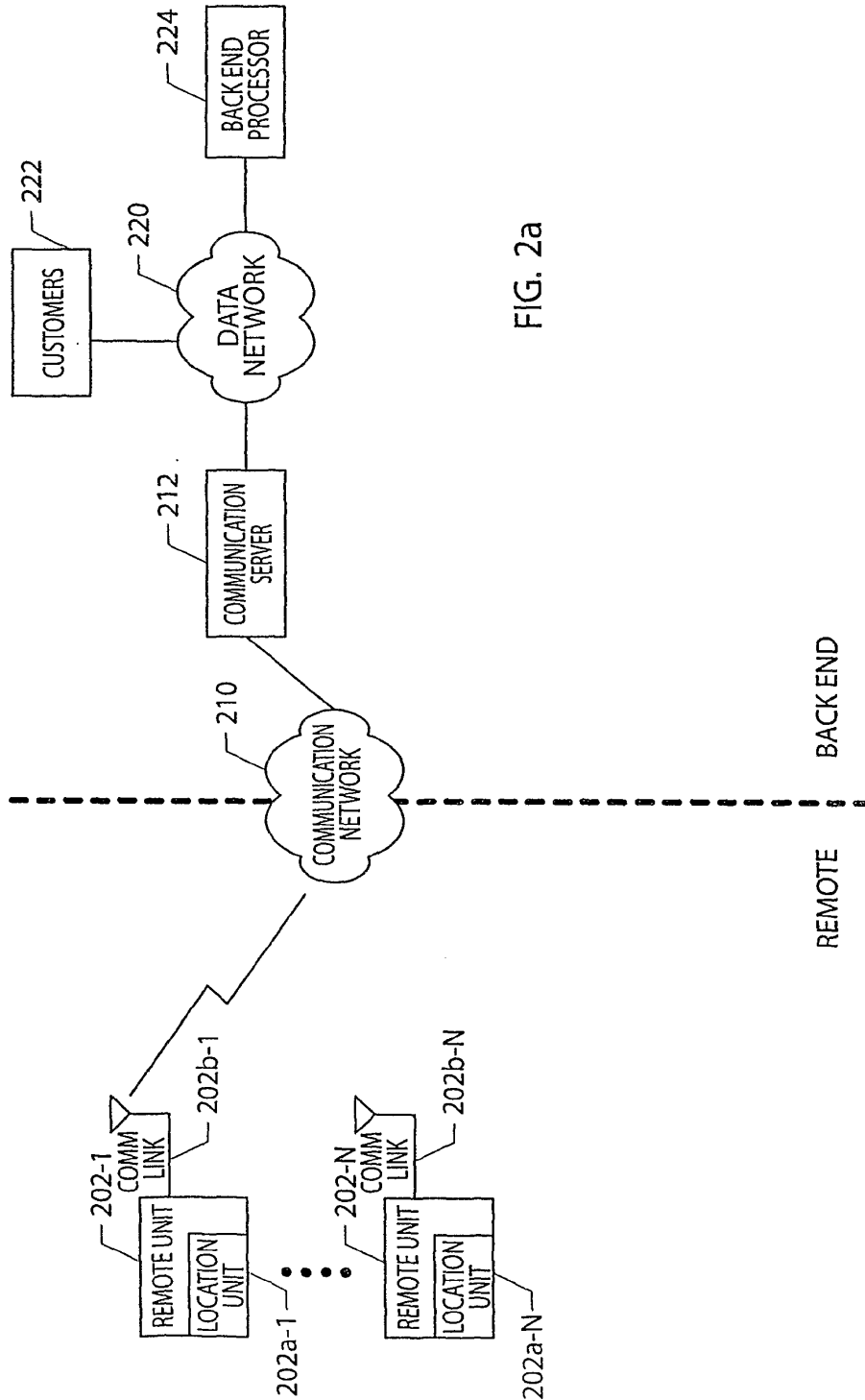


FIG. 2a

SUBSTITUTE SHEET (RULE 26)

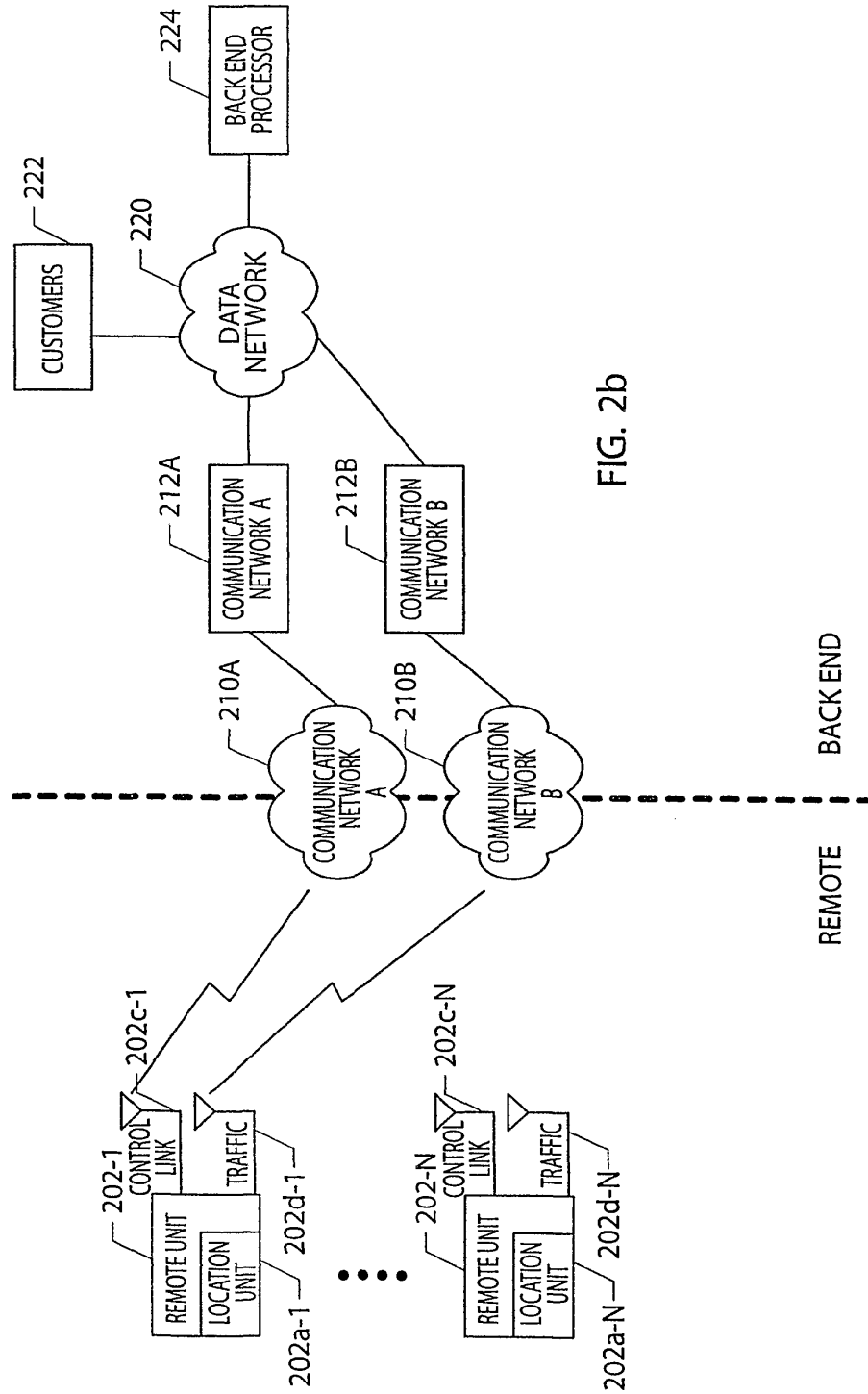


FIG. 2b

SUBSTITUTE SHEET (RULE 26)

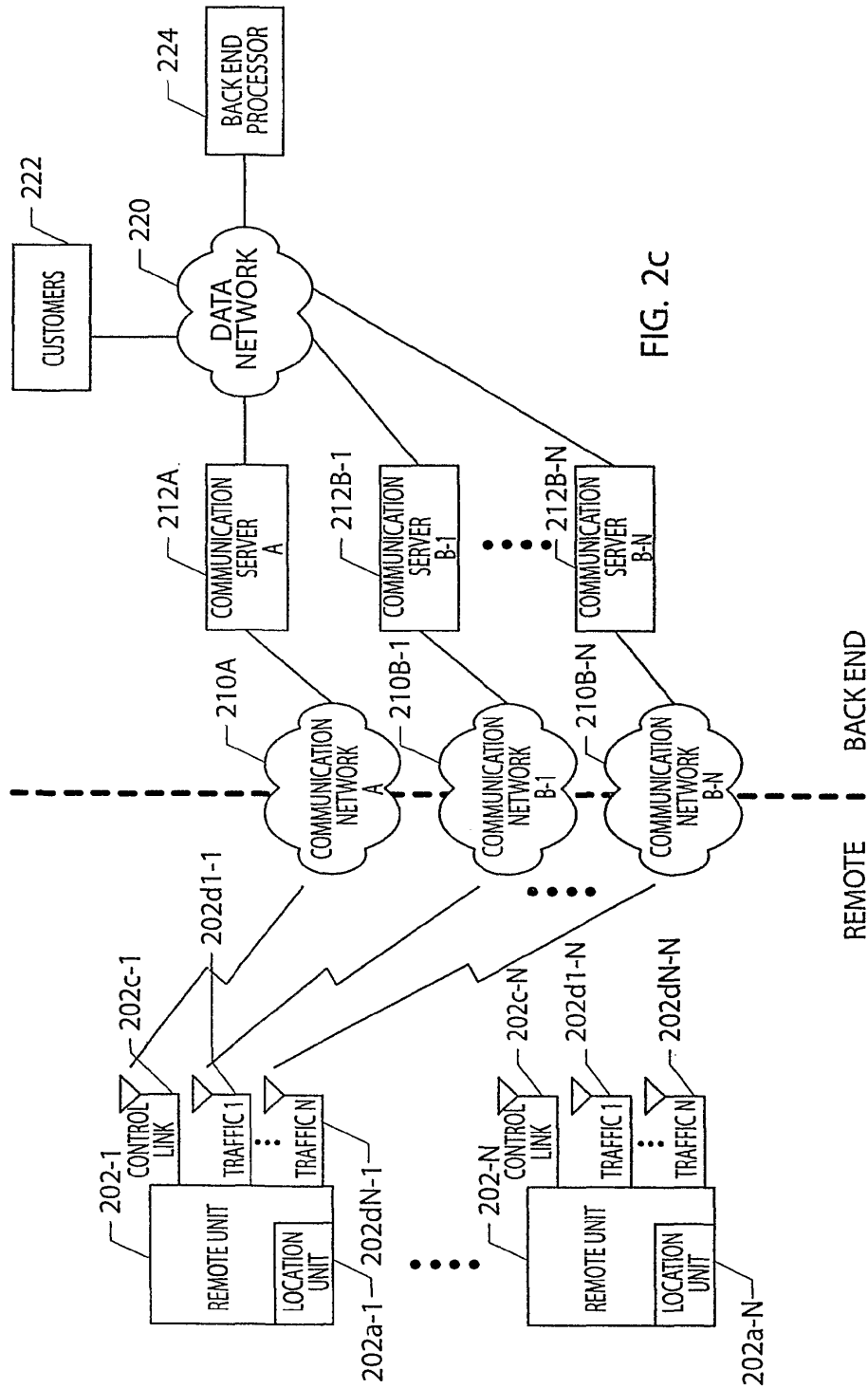


FIG. 2c

SUBSTITUTE SHEET (RULE 26)

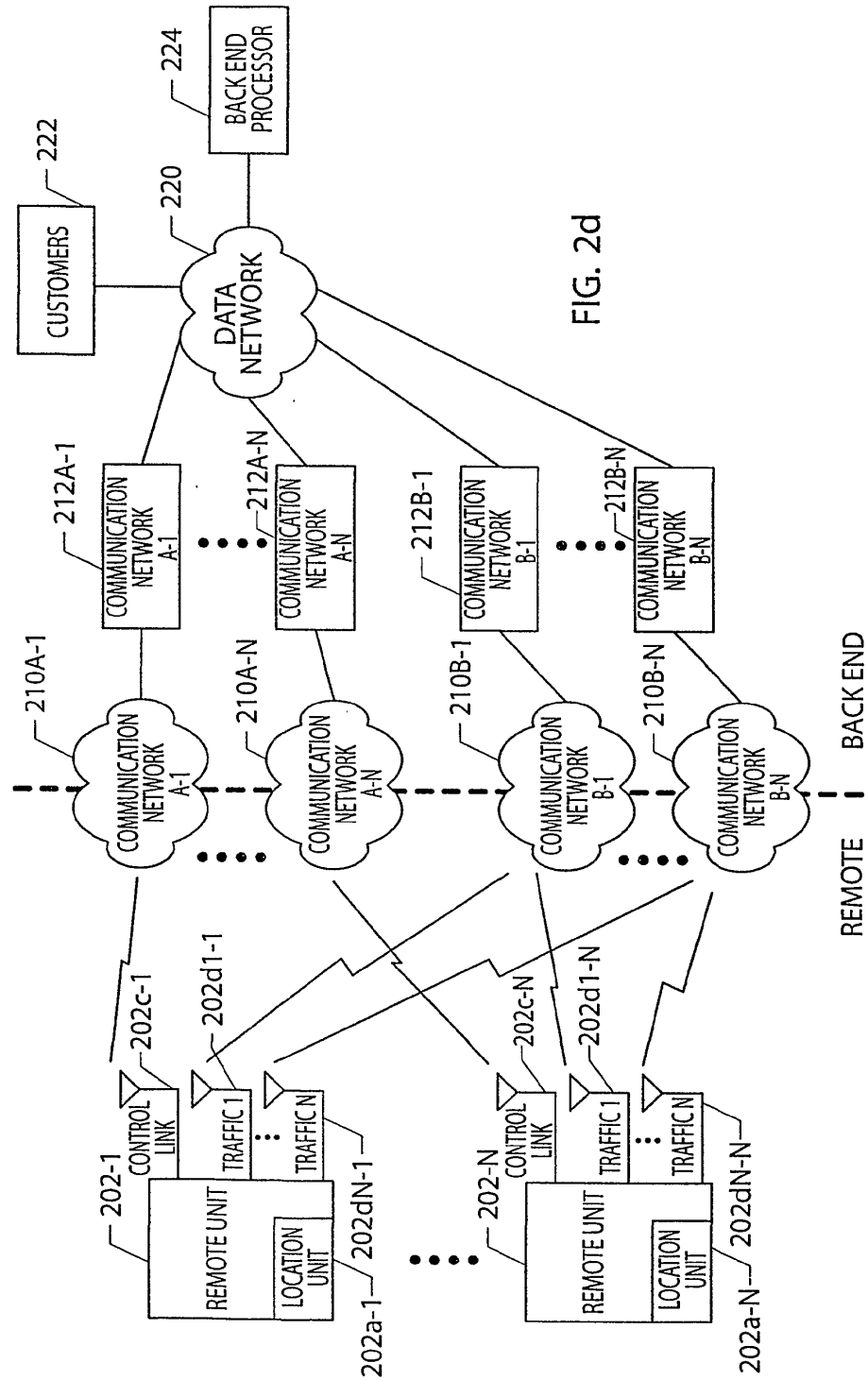


FIG. 2d

SUBSTITUTE SHEET (RULE 26)

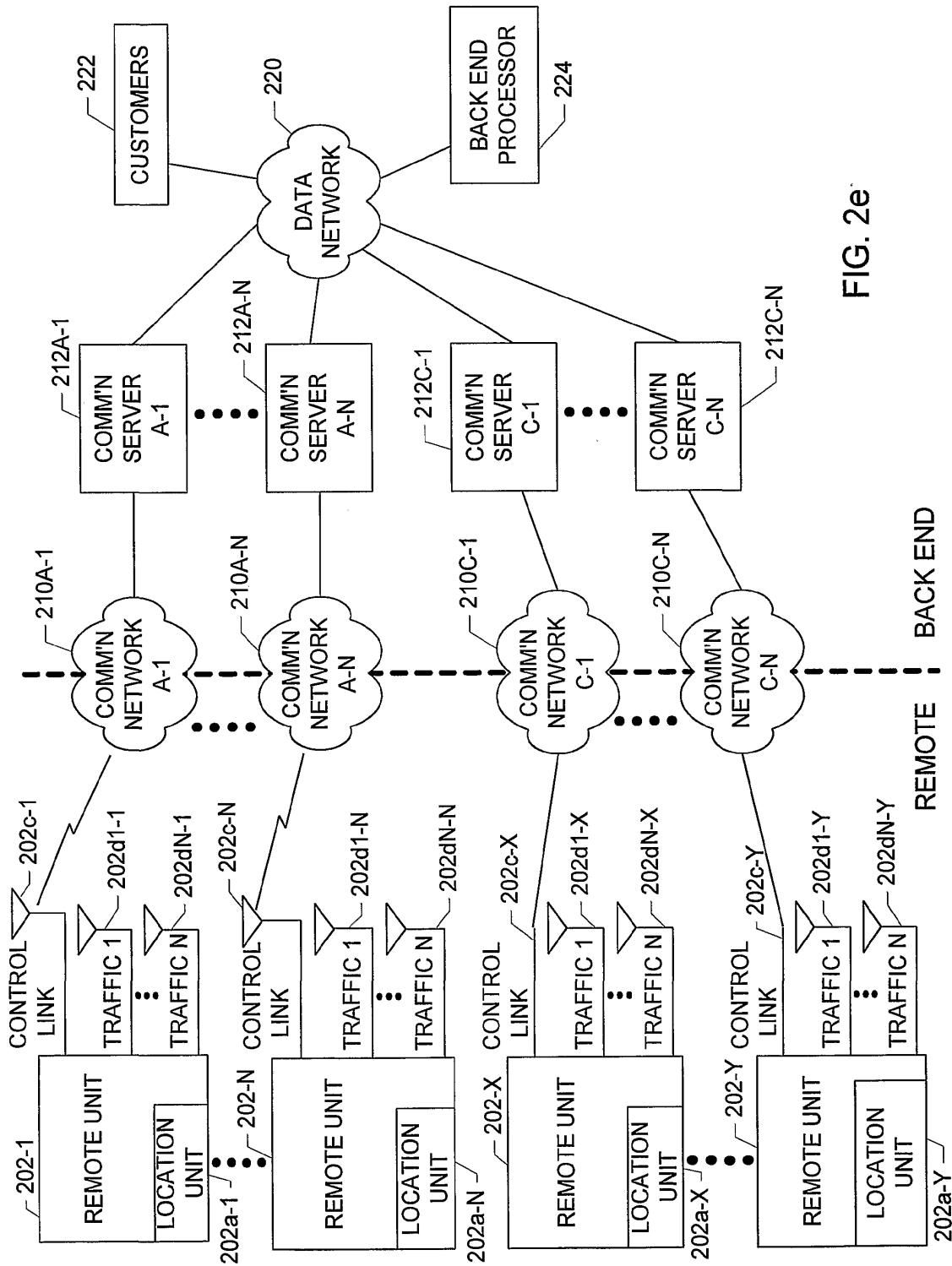


FIG. 2e

SUBSTITUTE SHEET (RULE 26)

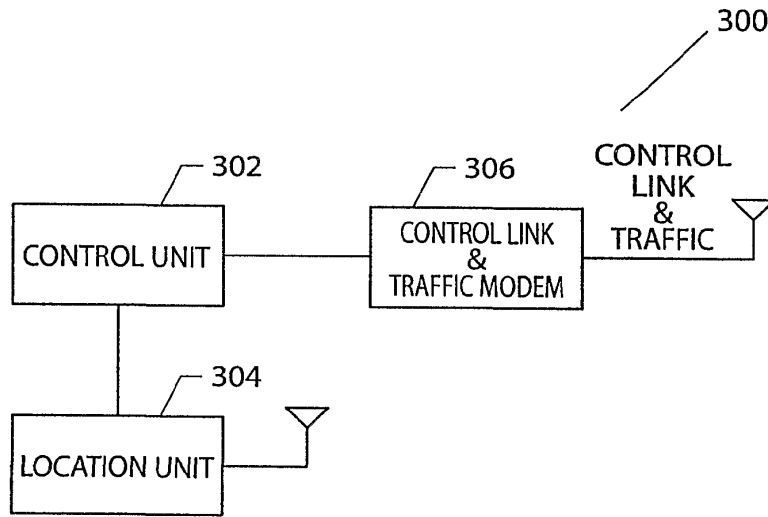


FIG. 3a

SUBSTITUTE SHEET (RULE 26)

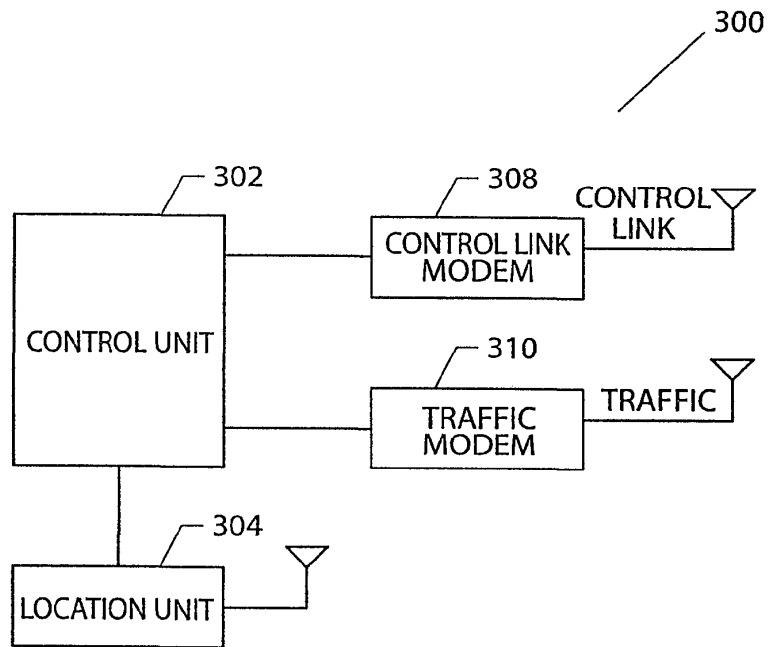


FIG. 3b

SUBSTITUTE SHEET (RULE 26)



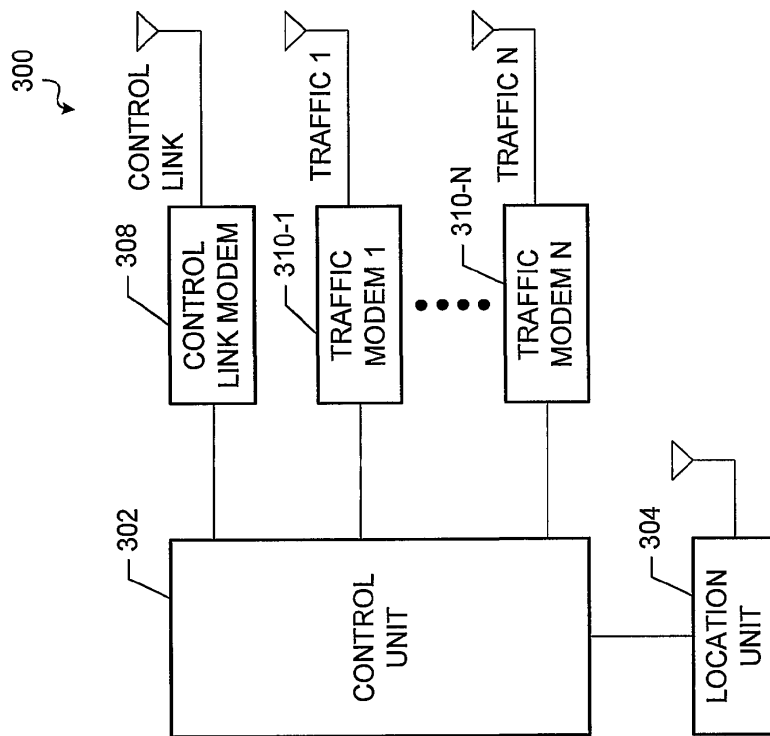


FIG. 3C

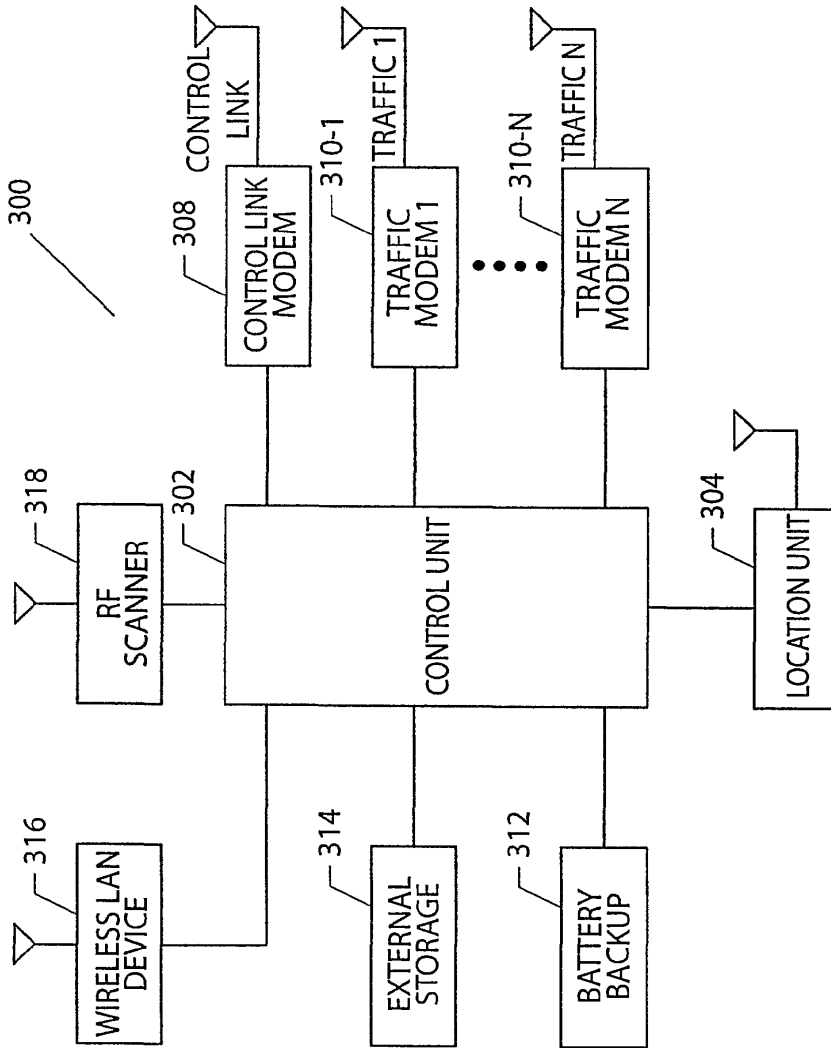


FIG. 3d

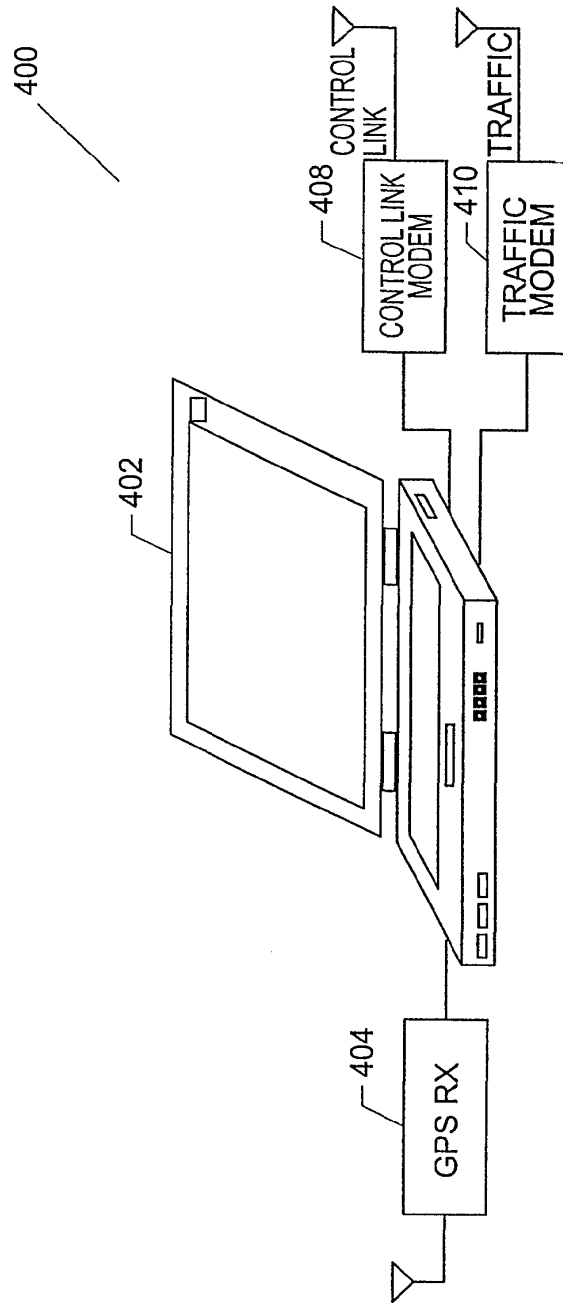


FIG. 4a

SUBSTITUTE SHEET (RULE 26)

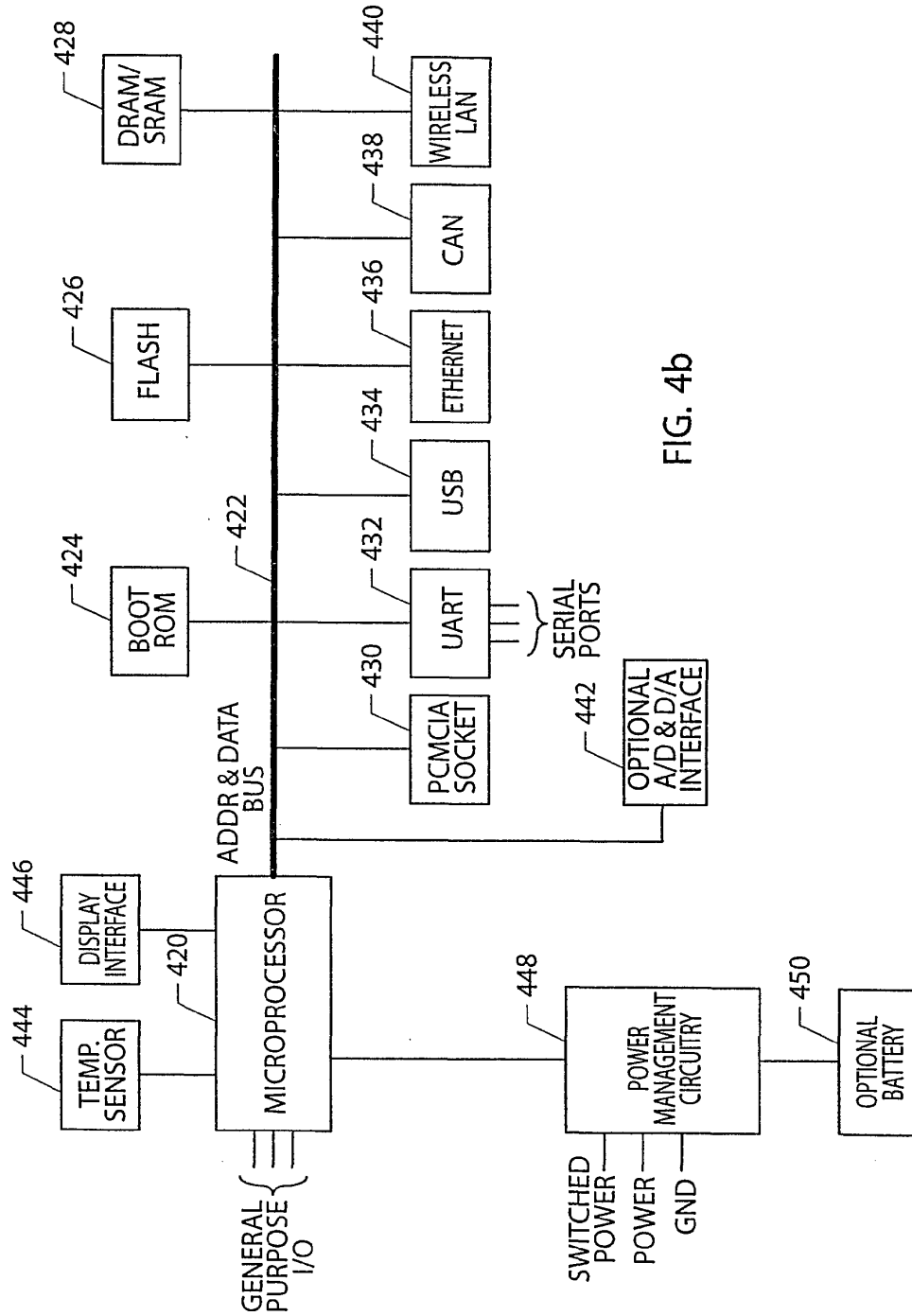


FIG. 4b

SUBSTITUTE SHEET (RULE 26)

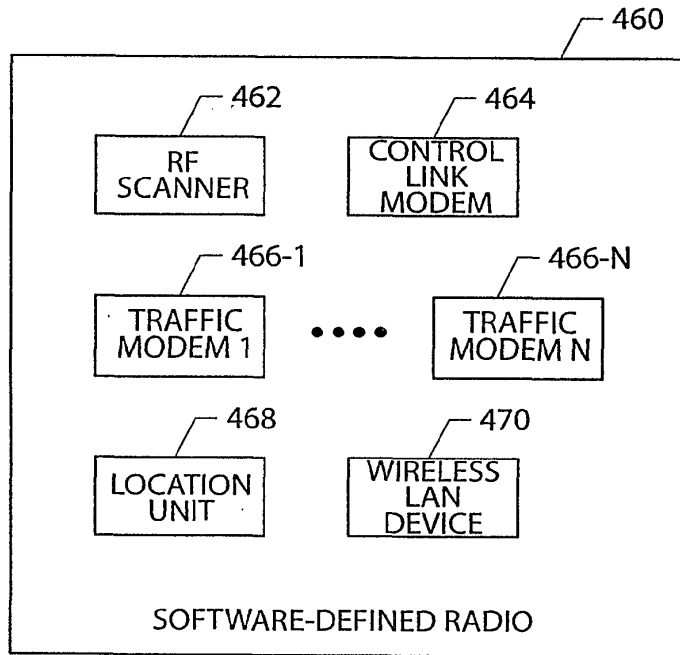


FIG. 4c

SUBSTITUTE SHEET (RULE 26)

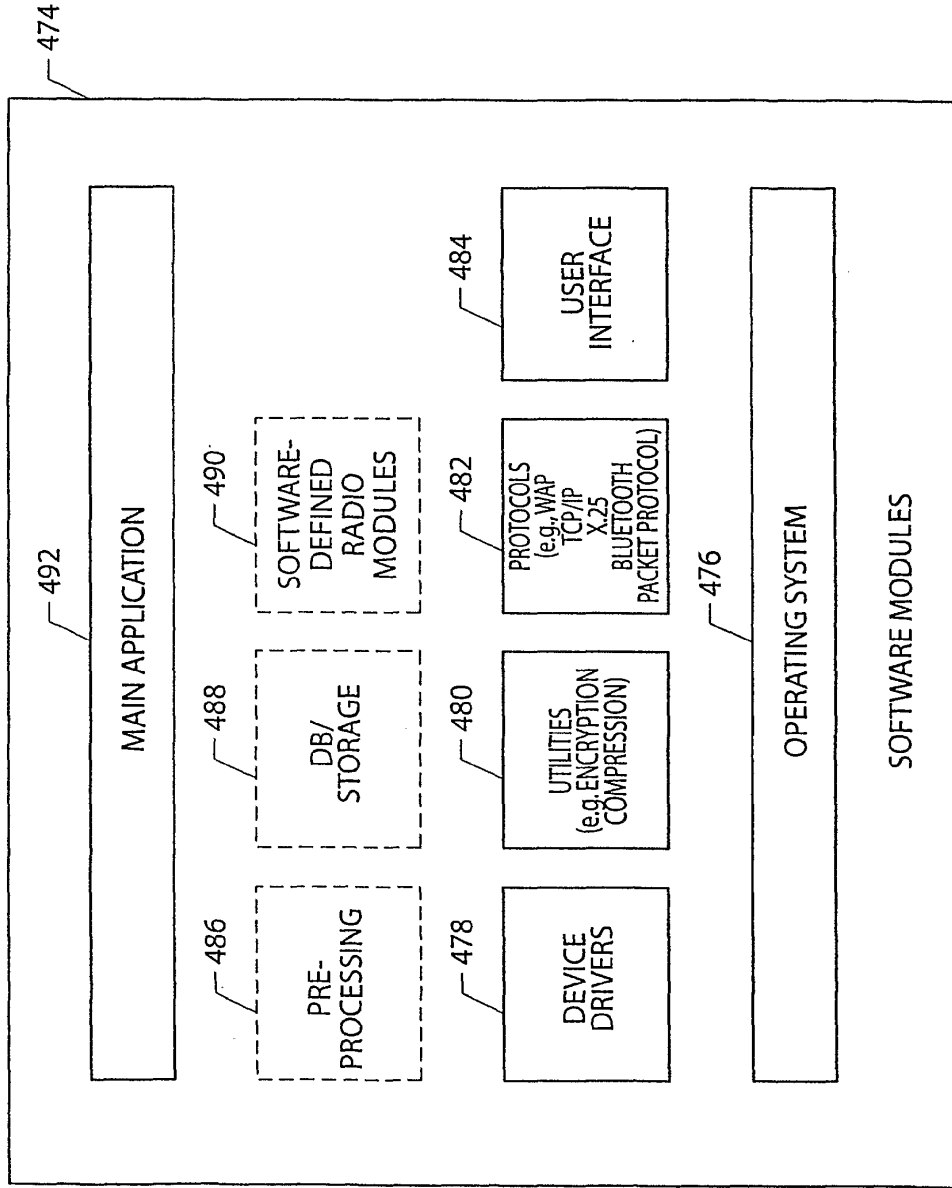


FIG. 4d

SUBSTITUTE SHEET (RULE 26)

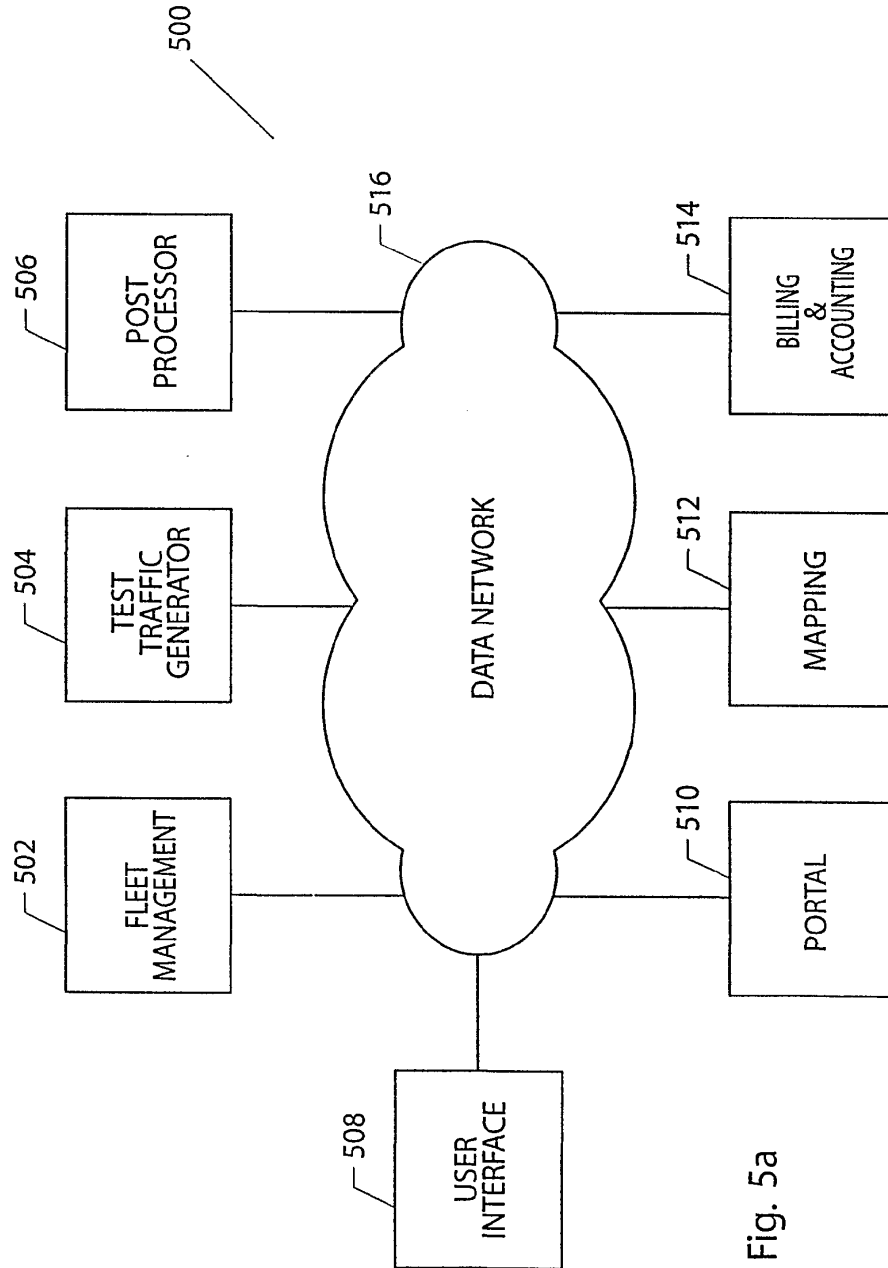


Fig. 5a

SUBSTITUTE SHEET (RULE 26)

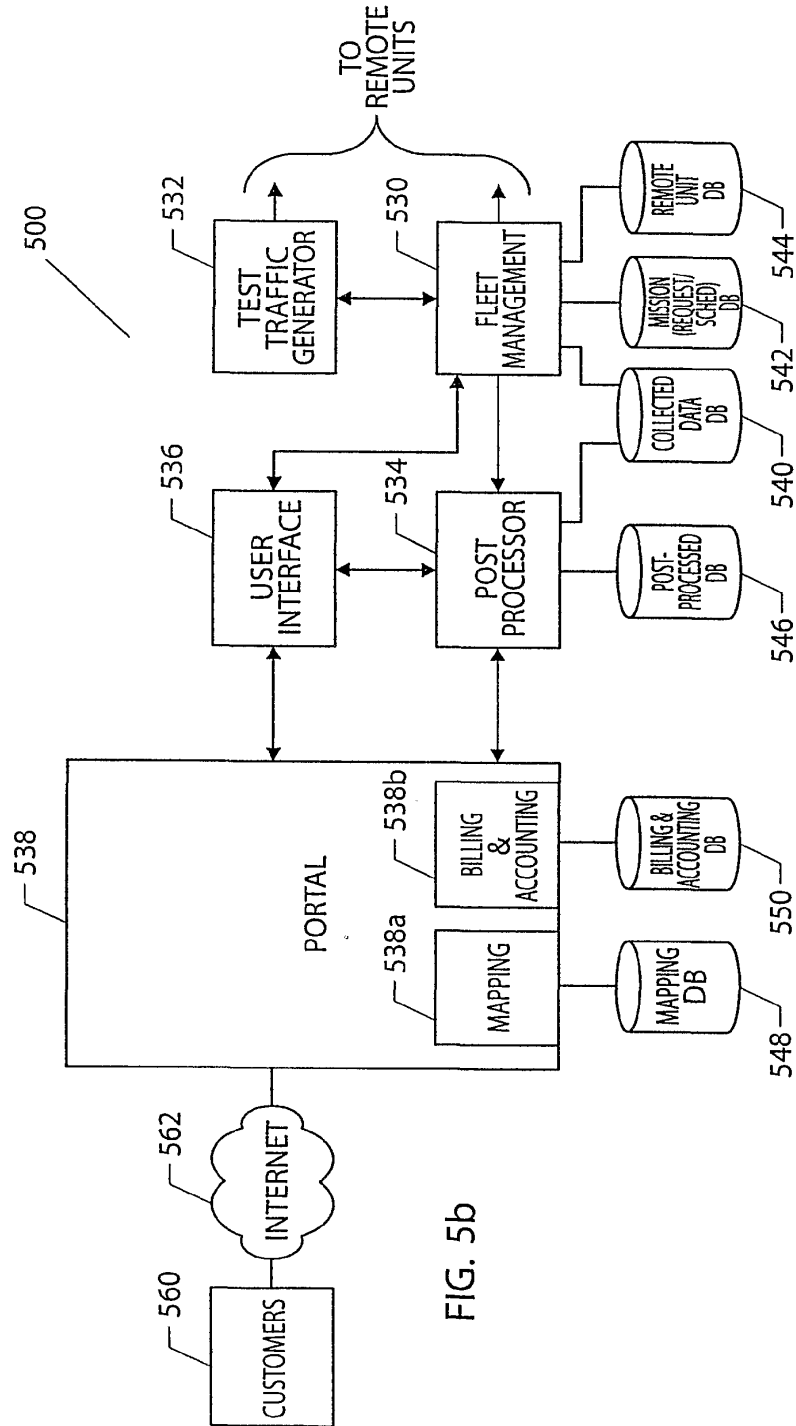


FIG. 5b

SUBSTITUTE SHEET (RULE 26)



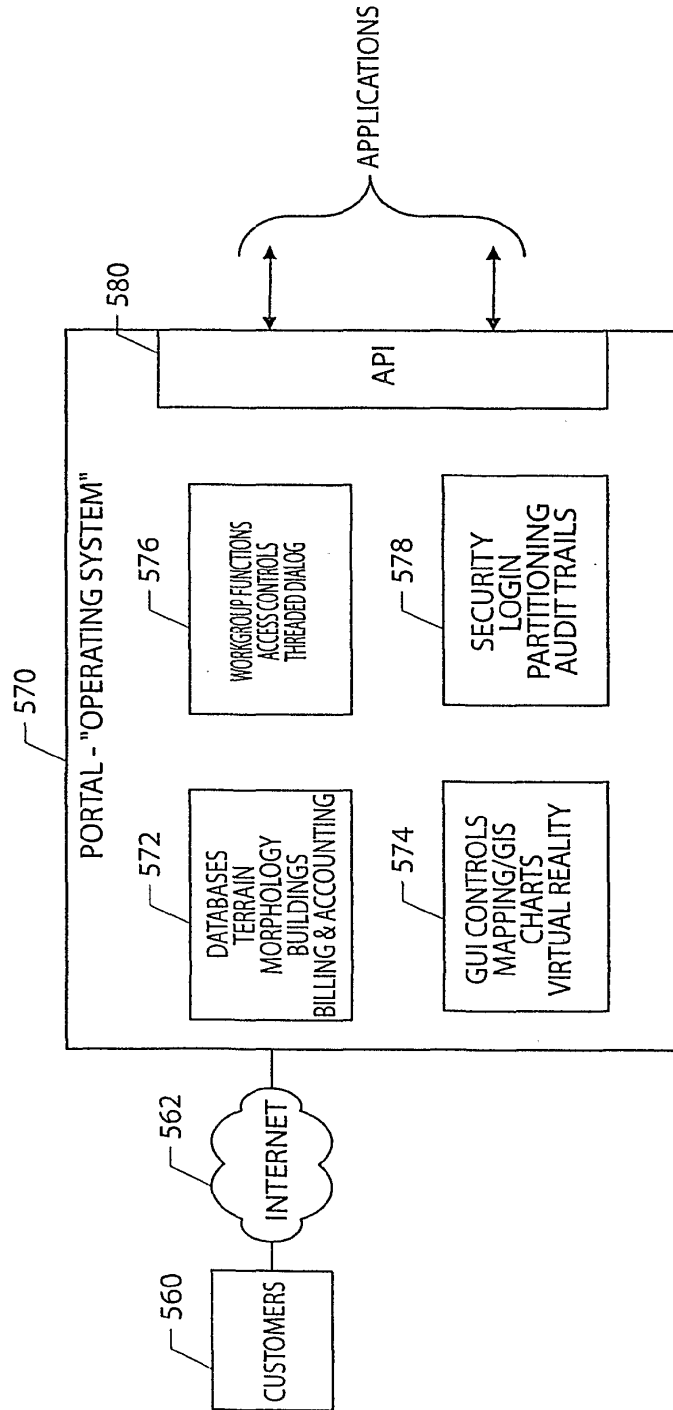


FIG. 5c

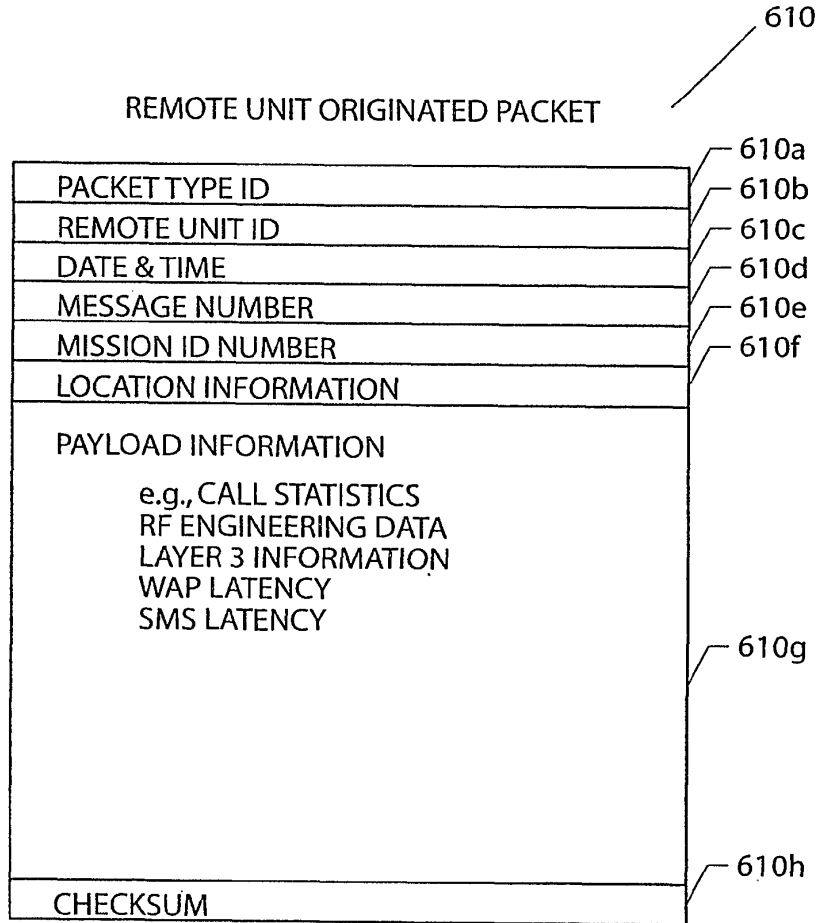


FIG. 6a

SUBSTITUTE SHEET (RULE 26)

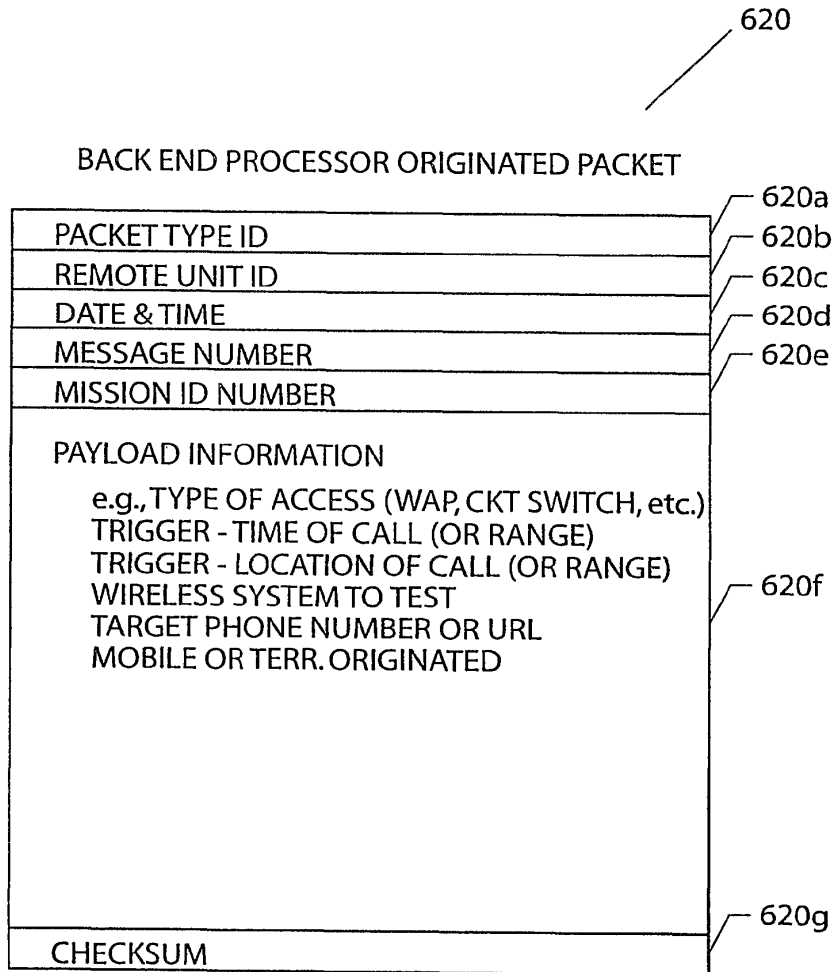


FIG. 6b

SUBSTITUTE SHEET (RULE 26)

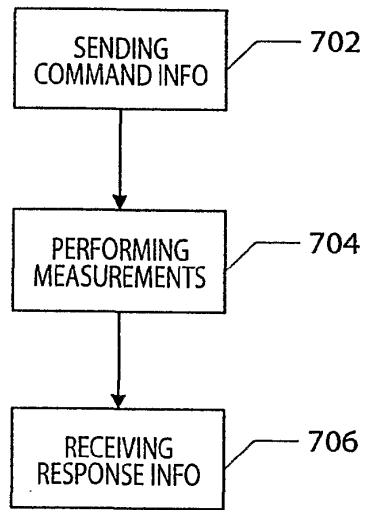


FIG. 7a

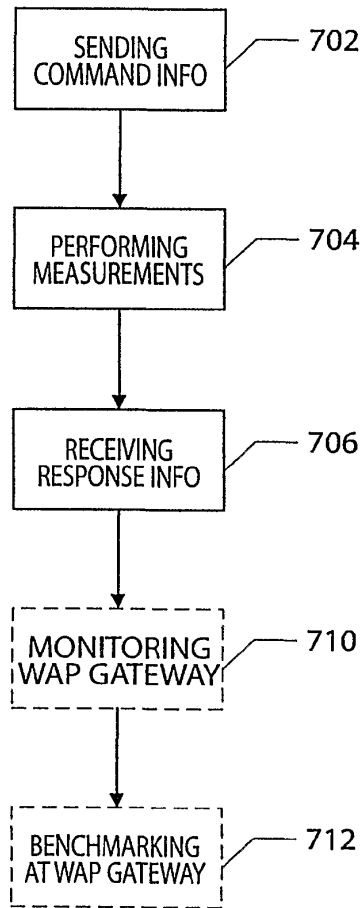


FIG. 7b

SUBSTITUTE SHEET (RULE 26)

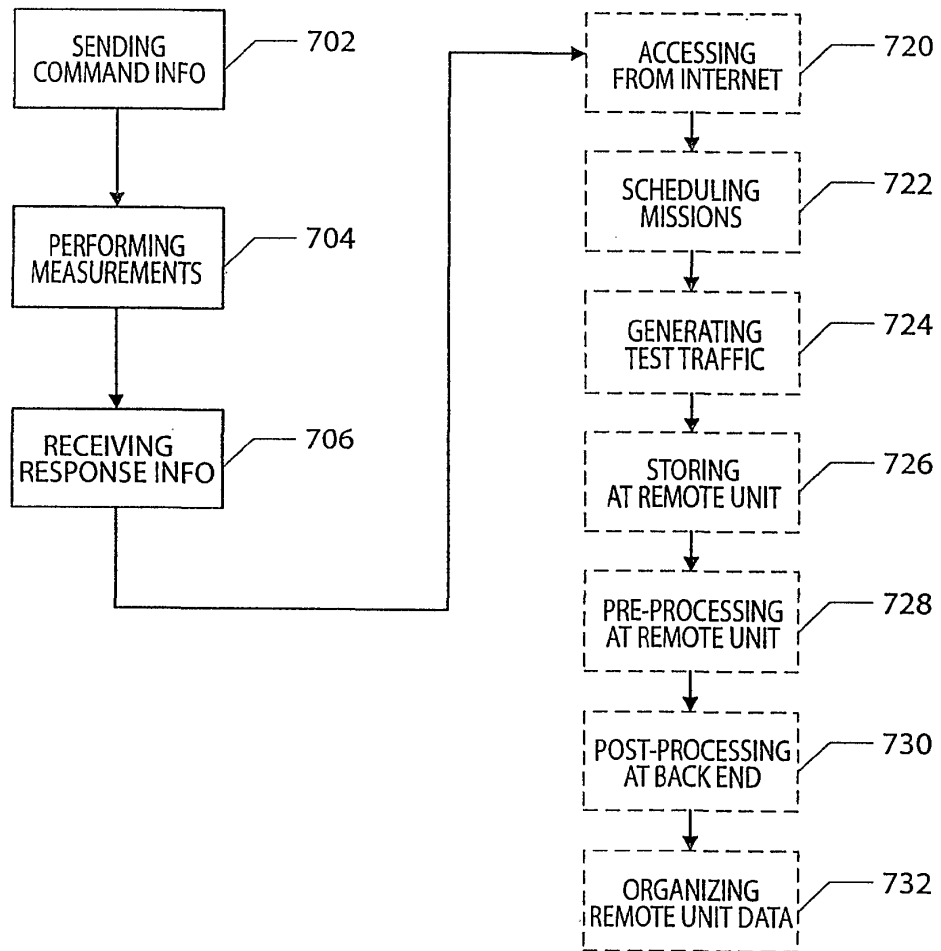


FIG. 7c

SUBSTITUTE SHEET (RULE 26)

30/42

810

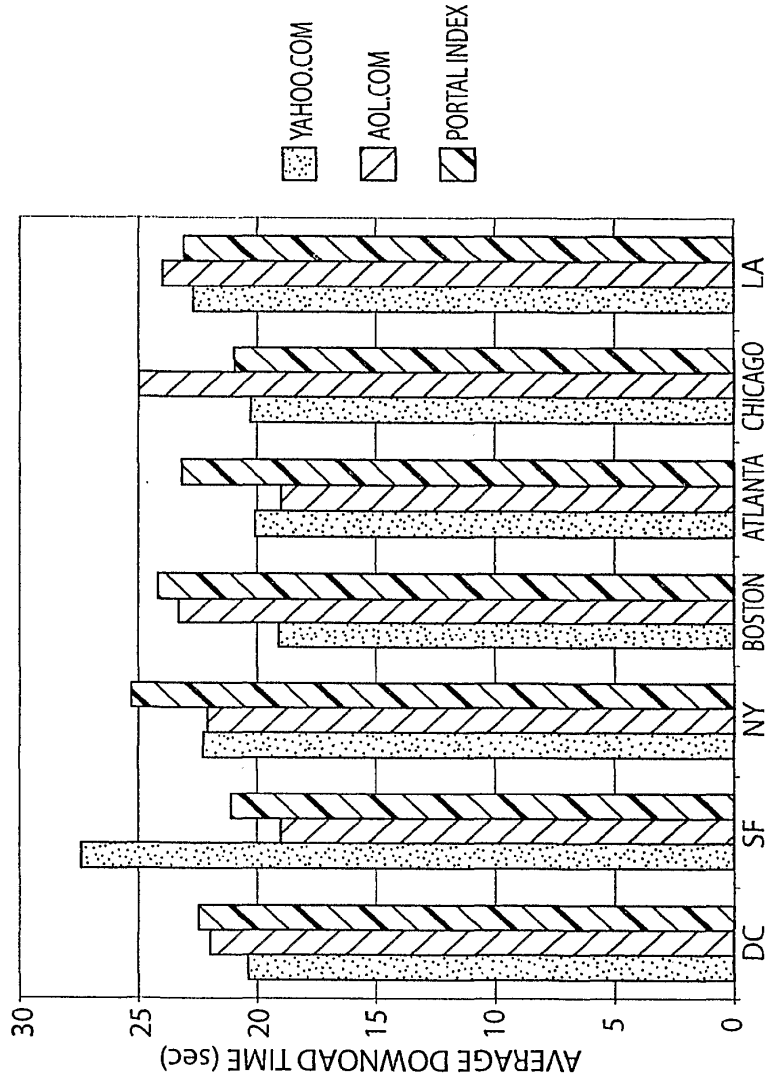


FIG. 8a

SERVICE: COMPARE PORTALS  
 REPORT: DOWNLOAD TIME  
 BY: CITY  
 BY: ALL CARRIERS  
 FREQUENCY: 15 MINUTES  
 TIME: 6 AM - 12 PM  
 PERIOD: 03/01/00 - 03/07/00  
 BENCHMARK: PORTAL INDEX  
 AOL.COM

SUBSTITUTE SHEET (RULE 26)

820

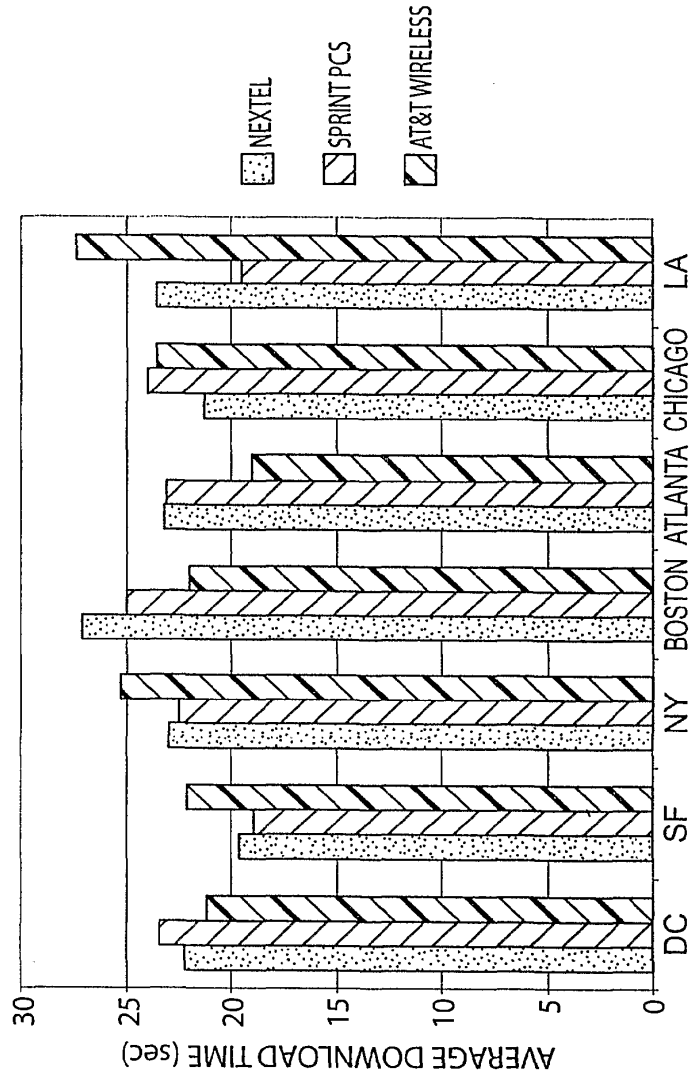


FIG. 8b

URL: YAHOO.COM  
 SERVICE: COMPARE WIRELESS OPERATORS  
 REPORT: DOWNLOAD TIME  
 BY: CITY  
 BY: CARRIER  
 FREQUENCY: 30 MINUTES  
 TIME: 6 AM - 9 PM  
 PERIOD: 03/01/00 - 03/07/00

SUBSTITUTE SHEET (RULE 26)



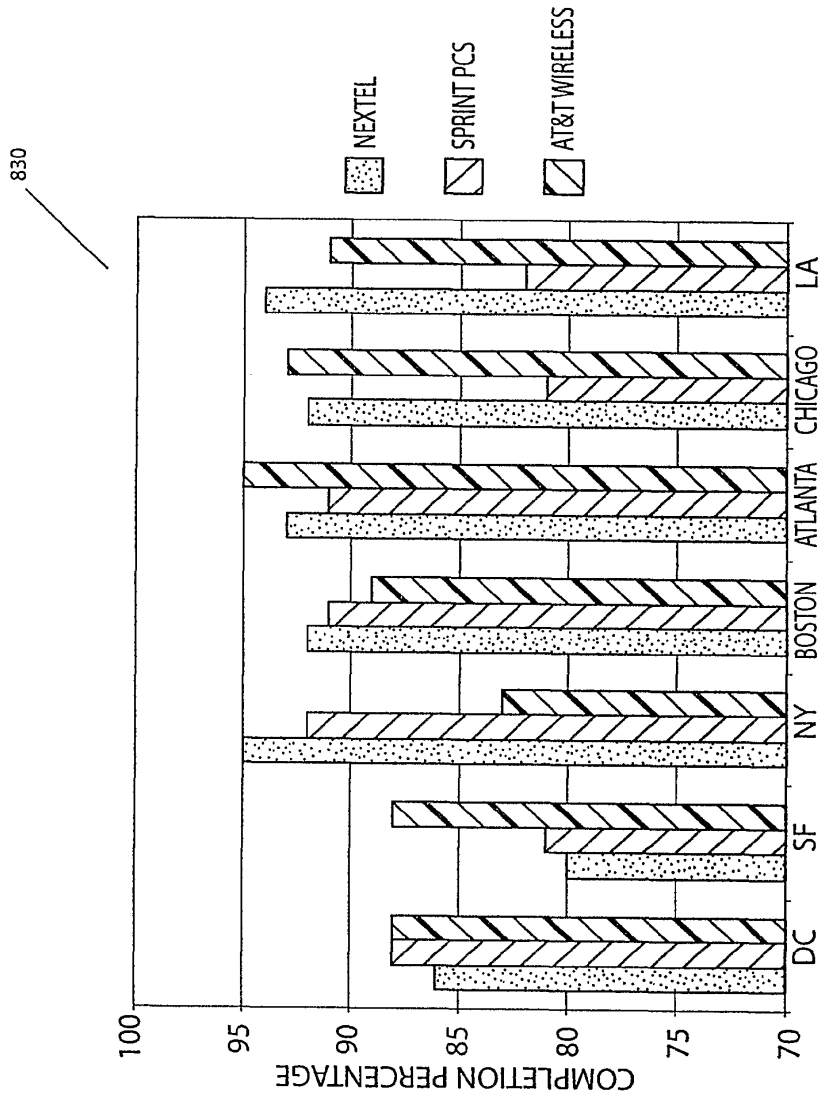


FIG. 8C

URL: YAHOO.COM  
 SERVICE: COMPARE WIRELESS OPERATORS  
 REPORT: COMPLETION PERCENT  
 BY: CITY  
 BY: CARRIER  
 FREQUENCY: 30 MINUTES  
 TIME: 6 AM - 9 PM  
 PERIOD: 03/01/00 - 03/07/00

SUBSTITUTE SHEET (RULE 26)

33/42

840

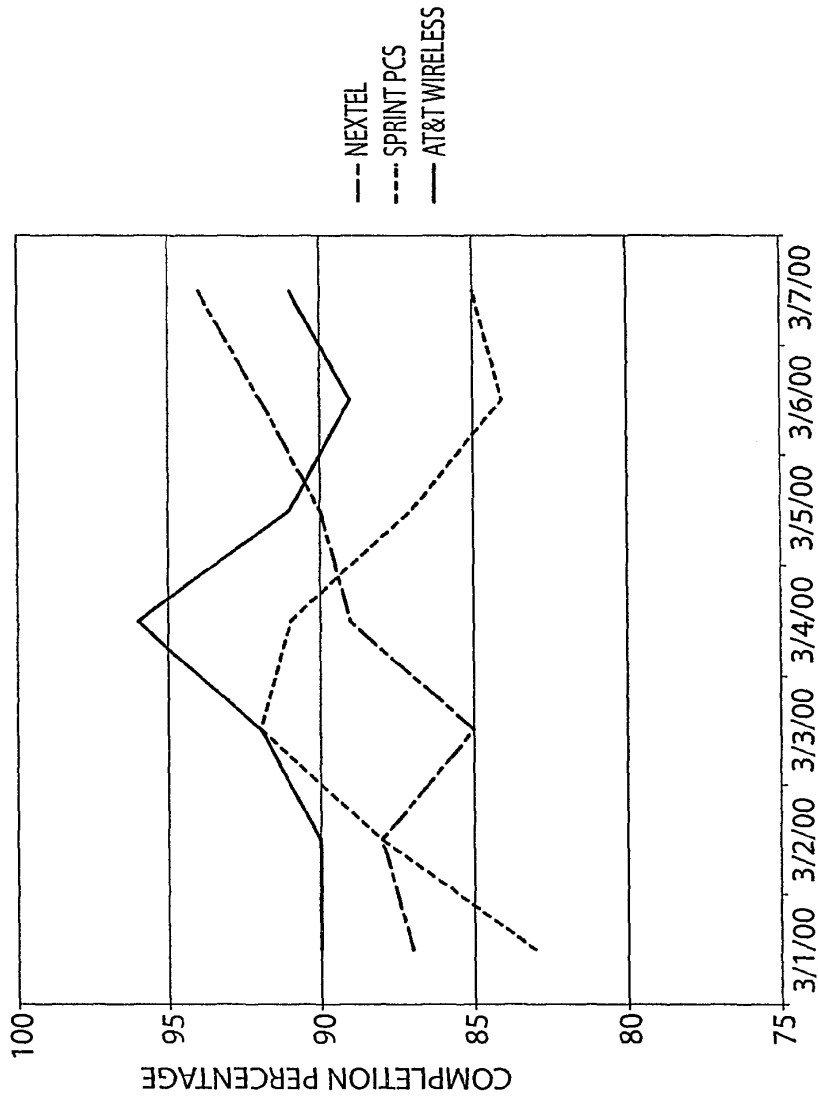


FIG. 8d

URL: YAHOO.COM  
 SERVICE: TREND WIRELESS OPERATORS  
 REPORT: COMPLETION PERCENT  
 BY: CITY  
 BY: CARRIER  
 FREQUENCY: 15 MINUTES  
 TIME: 6 AM - 9 PM  
 PERIOD: 03/01/00 - 03/07/00

SUBSTITUTE SHEET (RULE 26)

850

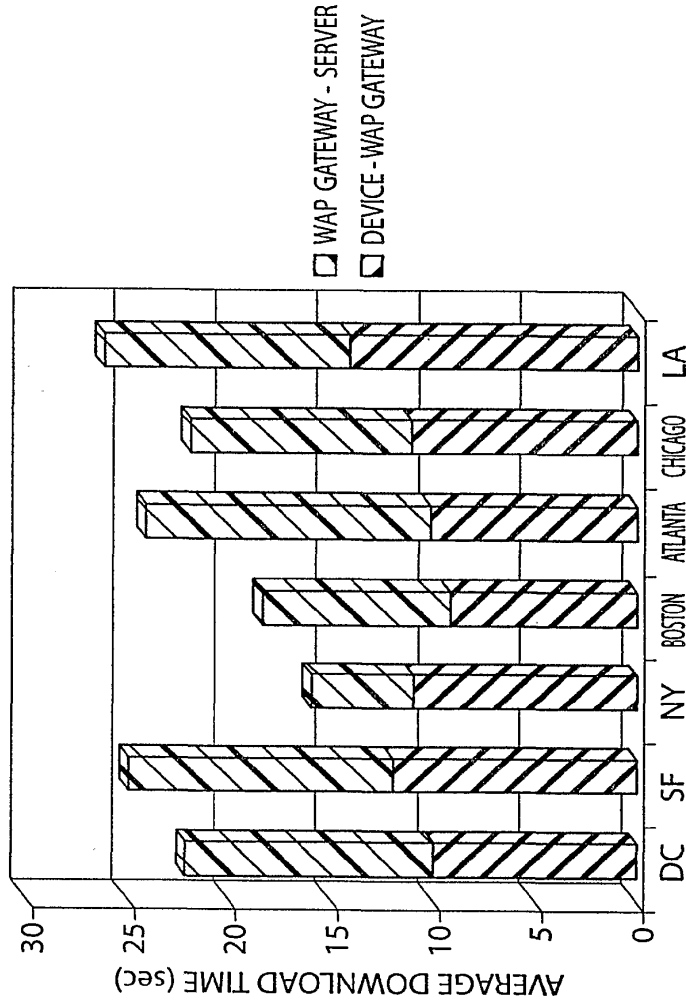


FIG. 8e

URL: YAHOO.COM  
 SERVICE: GATEWAY BREAKDOWN  
 REPORT: DOWNLOAD TIME COMPONENTS 1  
 BY: CITY  
 CARRIER:NEXTEL  
 FREQUENCY: 60 MINUTES  
 TIME: 12 PM - 12 PM  
 PERIOD: 03/01/00 - 03/07/00

SUBSTITUTE SHEET (RULE 26)

URL: YAHOO.COM  
 SERVICE: ERROR STATS  
 REPORT: ERROR REPORT  
 BY: ALL CITIES  
 CARRIER: ALL CARRIERS  
 FREQUENCY: 60 MINUTES  
 TIME: 12 PM - 12 PM  
 PERIOD: 03/01/00 - 03/07/00

860

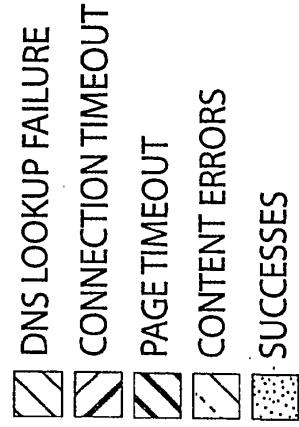
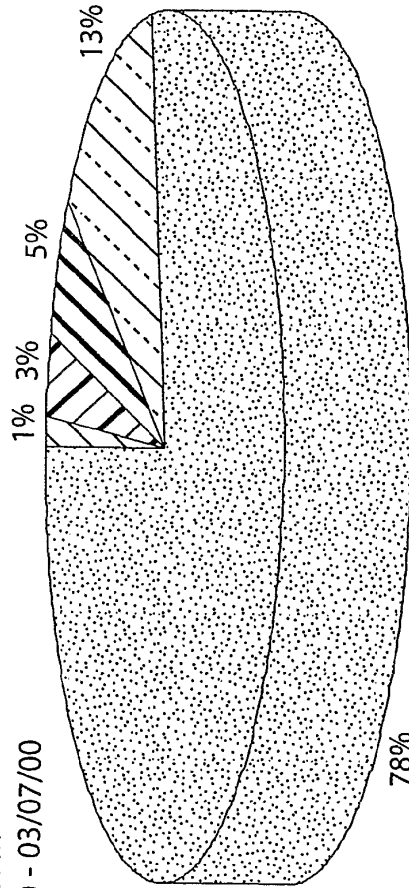


FIG. 8f

SUBSTITUTE SHEET (RULE 26)

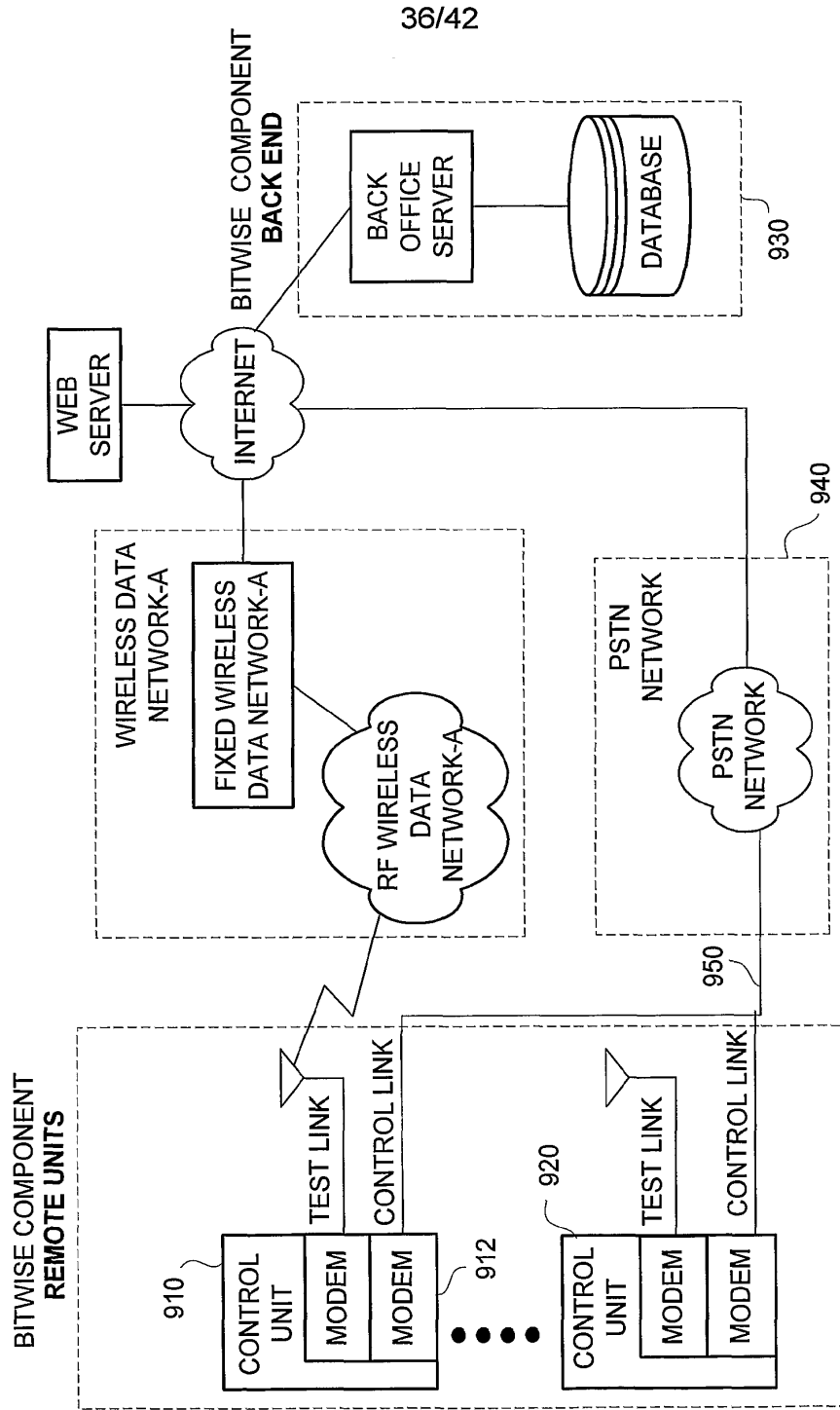


FIG. 9

SUBSTITUTE SHEET (RULE 26)

37/42

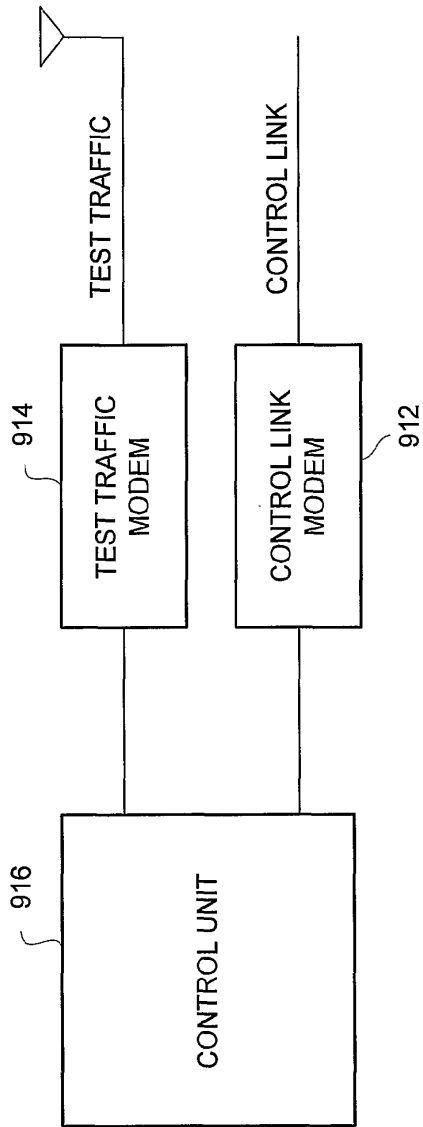


FIG. 10

SUBSTITUTE SHEET (RULE 26)

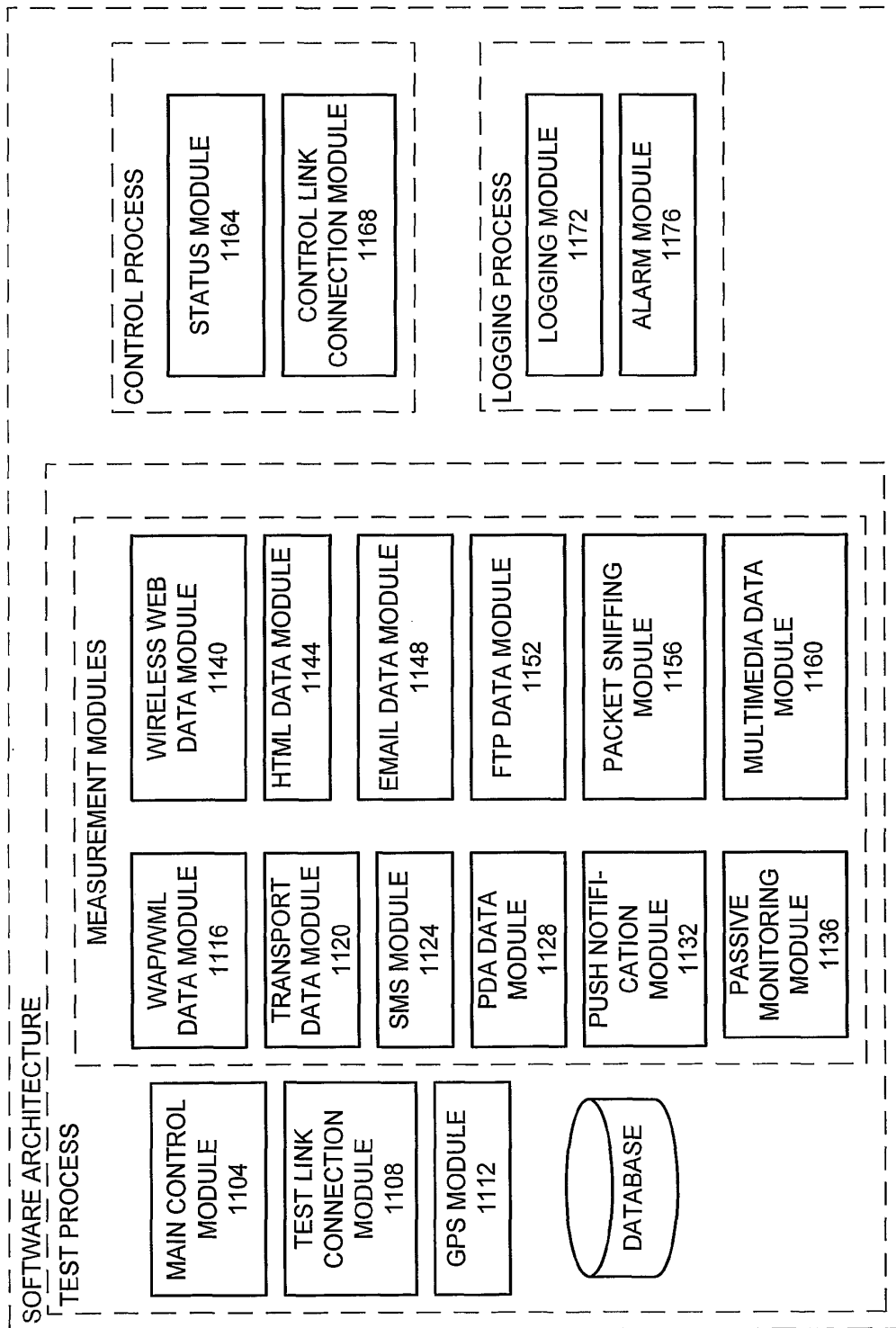


FIG. 11

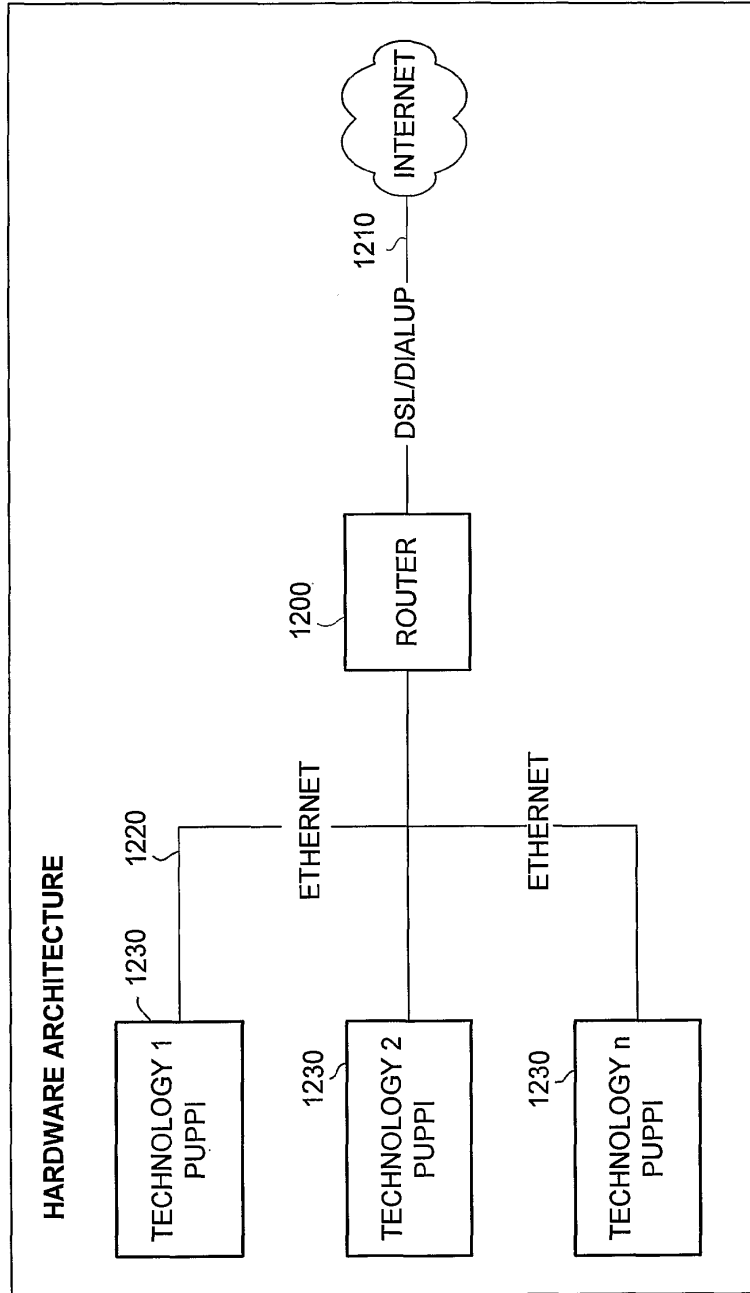


FIG. 12



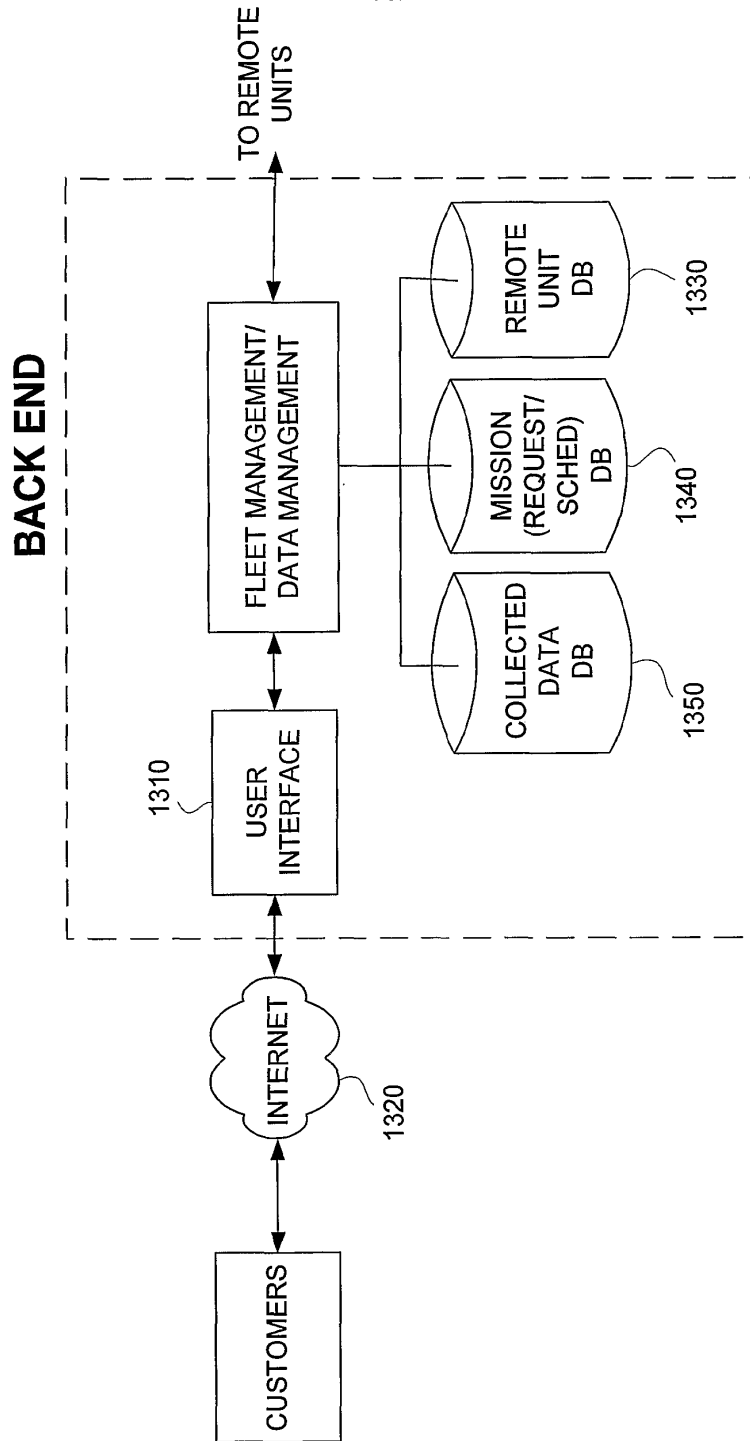


FIG. 13

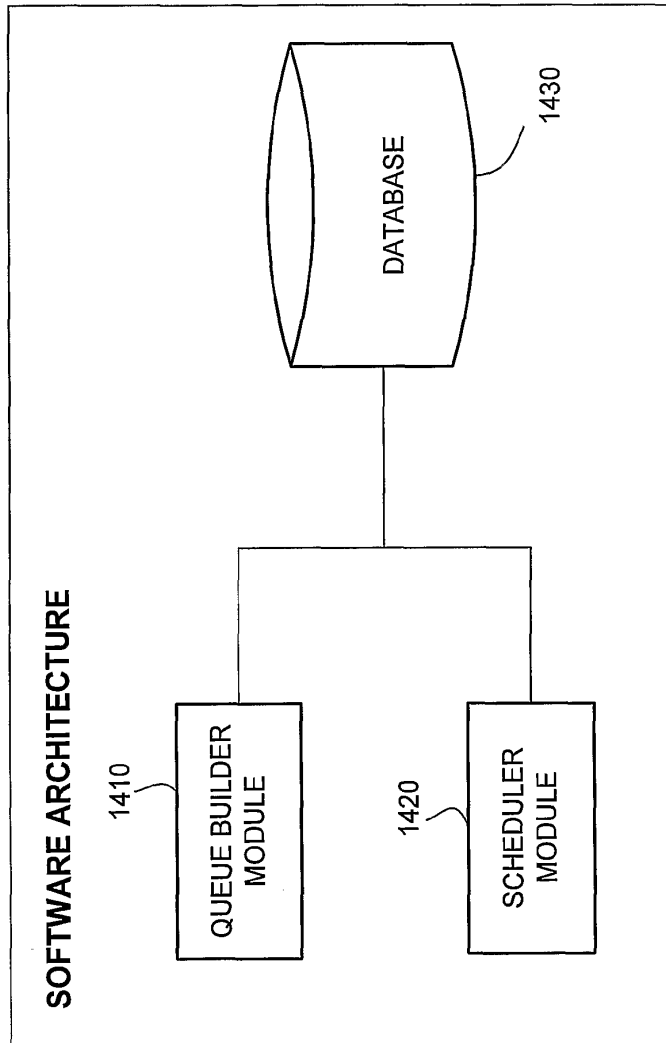


FIG. 14

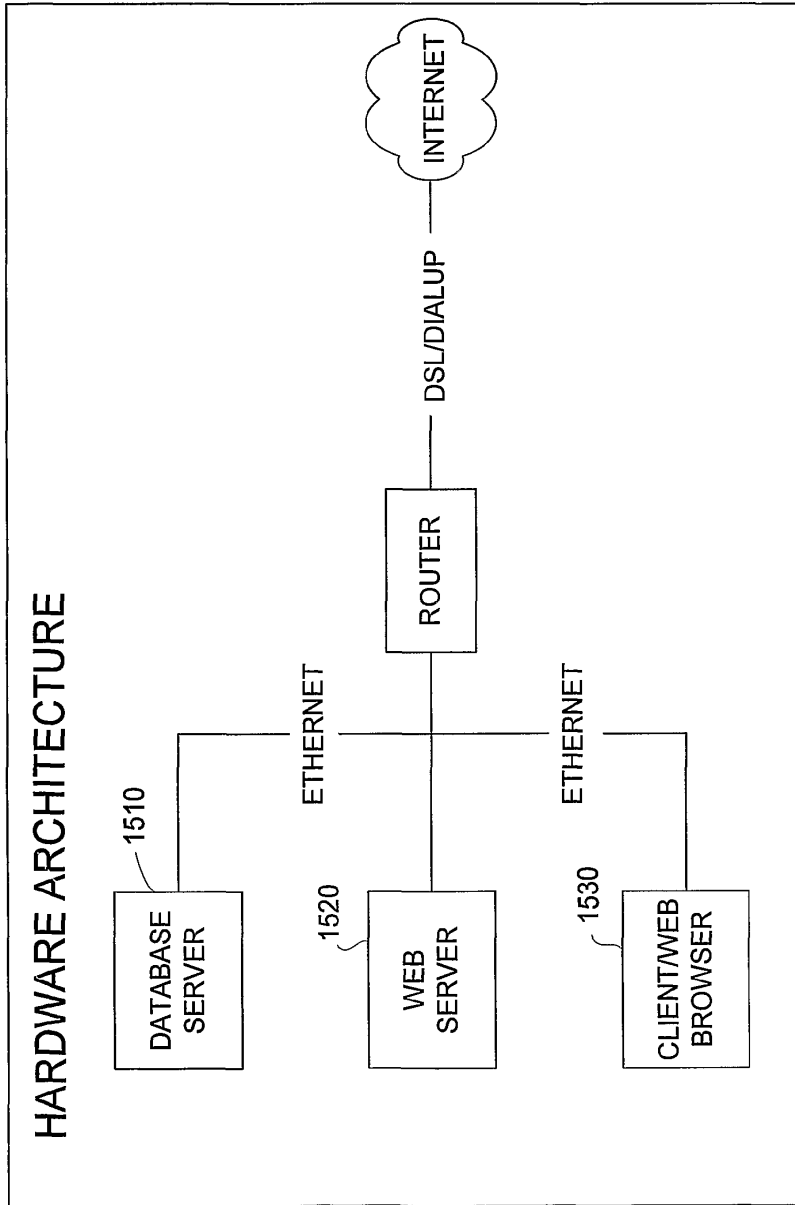


FIG. 15

(12) INTERNATIONAL APPLICATION PUBLISHED UNDER THE PATENT COOPERATION TREATY (PCT)

(19) World Intellectual Property Organization  
International Bureau



(43) International Publication Date  
17 October 2002 (17.10.2002)

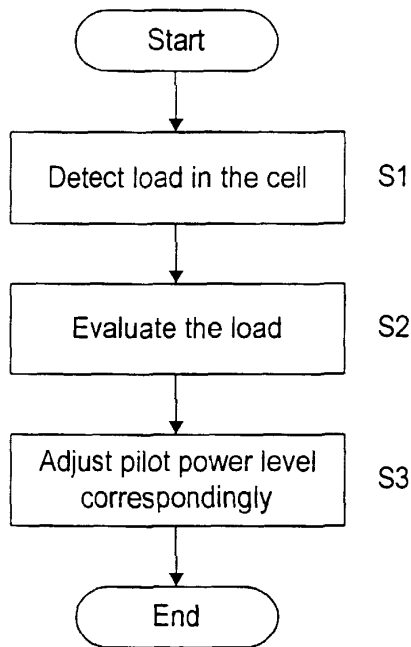
PCT

(10) International Publication Number  
**WO 02/082843 A1**

- (51) International Patent Classification<sup>7</sup>: **H04Q 7/36**
- (21) International Application Number: PCT/EP01/03985
- (22) International Filing Date: 6 April 2001 (06.04.2001)
- (25) Filing Language: English
- (26) Publication Language: English
- (71) Applicant (for all designated States except US): **NOKIA CORPORATION** [FI/FI]; Keilalahdentie 4, FIN-02150 Espoo (FI).
- (72) Inventors; and
- (75) Inventors/Applicants (for US only): **SIPILÄ, Kari** [FI/FI]; Hiirisuotie 11 B 2, FIN-01690 Vantaa (FI). **SCHWARZ, Uwe** [DE/FI]; Männistöntie 12 G 4, FIN-02880 Veikkola (FI).
- (74) Agents: **LESON, Thomas, Johannes, Alois** et al.; Tiedtke-Bühling-Kinne, Bavariaring 4, 80336 Munich (DE).
- (81) Designated States (national): AE, AG, AL, AM, AT, AU, AZ, BA, BB, BG, BR, BY, BZ, CA, CH, CN, CR, CU, CZ, DE, DK, DM, DZ, EE, ES, FI, GB, GD, GE, GH, GM, HR, HU, ID, IL, IN, IS, JP, KE, KG, KP, KR, KZ, LC, LK, LR, LS, LT, LU, LV, MA, MD, MG, MK, MN, MW, MX, MZ, NO, NZ, PL, PT, RO, RU, SD, SE, SG, SI, SK, SL, TJ, TM, TR, TT, TZ, UA, UG, US, UZ, VN, YU, ZA, ZW.
- (84) Designated States (regional): ARIPO patent (GH, GM, KE, LS, MW, MZ, SD, SL, SZ, TZ, UG, ZW), Eurasian patent (AM, AZ, BY, KG, KZ, MD, RU, TJ, TM), European patent (AT, BE, CH, CY, DE, DK, ES, FI, FR, GB, GR, IE, IT, LU, MC, NL, PT, SE, TR), OAPI patent (BF, BJ, CF, CG, CI, CM, GA, GN, GW, ML, MR, NE, SN, TD, TG).
- Published:**  
— with international search report

[Continued on next page]

(54) Title: METHOD OF ADJUSTING THE CAPACITY OF A CELL



(57) Abstract: The invention proposes a method for controlling a network comprising at least one cell served by a first type network device, wherein the first type network device is adapted to serve second type network devices, the method comprising the steps of detecting (S1) the downlink load of the cell in a direction from the first type network device to the second type network device, deciding (S2) whether the first type network device serving the cell is suited to serve sufficient service to second type network devices requesting service in the cell with respect to the detected downlink load, generating (S3) information as to the attractiveness of the first type network device based on the result of the deciding step, and providing the information to the second type network devices. The invention proposes also a device for controlling a network. By the method and the device, the load on a network can be more evenly distributed.

WO 02/082843 A1



---

*For two-letter codes and other abbreviations, refer to the "Guidance Notes on Codes and Abbreviations" appearing at the beginning of each regular issue of the PCT Gazette.*

## METHOD OF ADJUSTING THE CAPACITY OF A CELL

Field of the invention

5

The present invention relates to method and a device for controlling a network, wherein varying capacities in cells are handled.

10

BACKGROUND OF THE INVENTION

In mobile communication technologies like, e.g., UMTS (Universal Mobile Telecommunication System) or GSM (Global System for Mobile telecommunication), base stations serve a limited number of mobile users according to the current location of the users. As long as a user is in a base station cell area, he can obtain mobile services from that base station. Due to the inherent mobility in the system, available capacity in one cell might not be used whereas in another cell there can be too many users in the cell area at the same time. Cell areas of usually different sizes and a varying user density increase this inbalance, thus wasting nominally available and expensive network capacity.

In UMTS networks this problem is emphasized in downlink direction, i.e. from base station to mobile station. This is because most probably the downlink will be the capacity limiting direction due to the downlink intensive services such as for example web-browsing or streaming video

Despite thorough network planning, hard or soft limits of a mobile phone network can refuse additional mobile phone

35

users to get service in one cell even if some spare capacity is left in other cells, i.e. at other locations of the network. Thus, service can not be provided even if the network as a whole could support more services.

5

This is in particular a problem in case high capacity is needed temporarily, as, for example, during large sport events or open air festivals which occur only a few times in a year. A solution in which additional base stations are provided involves high costs and is therefore not acceptable.

10

#### SUMMARY OF THE INVENTION

15

Therefore, the object underlying the invention resides in providing a method and a device for controlling a network wherein a varying load on the cells of the network can be handled.

20

This object is solved by a method for controlling a network comprising at least one cell by a first type network device, wherein the first type network device is adapted to serve second type network devices, the method comprising the steps of

25

detecting the downlink load of the cell in a direction from the first type network device to the second type network device,

deciding whether the first type network device serving the cell is suited to serve sufficient service to second type network devices requesting service in the cell with respect to the detected downlink load,

30

generating information as to the attractiveness of the first type network device based on the result of the deciding step, and

35

providing the information to the second type network devices.

Alternatively, the above object is solved by a network control device in a network comprising at least one cell served by a first type network device, wherein the first type network device is adapted to serve second type network devices, wherein the network control device is further adapted

10 to detect downlink load of the cell in a direction from the first type network device to the second type network device, to decide whether the first type network device serving the cell is suited to serve sufficient service to second type network devices requesting service

15 in the cell with respect to the detected downlink load, to generate information as to the attractiveness of the first type network device based on the result of the deciding step, and to provide the information to the second type network devices.

20 Thus, by automatically determining if a cell is heavily loaded, the attractiveness information can be adjusted such that less second type network devices (e.g., mobile stations) are allowed to be served by the cell. Hence, a

25 reliable service in the cell can be established.

In this way, a varying load in the cell can be handled.

Hence, the network can automatically respond to load

30 distribution varying over a short time (within a few hours or even minutes). Temporary 'hotspots' (e.g. sport events or other open air events) are better served.

For the decision, the load on the cell may be compared

35 with the load on at least one neighbouring cell, wherein



the attractiveness information is set based on the comparison. Thus, by taking into account the load on neighbouring cells, a more even distribution on the cells in a network can be achieved.

5

In case the comparison results in that the load of the cell is higher than in the neighbouring cell, the attractiveness information may be set such that the area in which second type network devices are served in the cell is set smaller. On the other hand, in case the comparing step results in that the load of the cell is smaller than in the neighbouring cell, the attractiveness information may be set such that the area in which second type network devices are served in the cell is set larger.

10  
15

The attractiveness information may be the power level of a pilot signal. The pilot signal is a signal provided by each base station, which carries a bit sequence or code known by the mobile stations. Thus, an already known information can be used to indicate to other second type network elements (e.g., mobile stations) whether they should prefer one cell or another in selecting the serving cell or cells for communication.

20  
25

The pilot signal may be a signal broadcasted throughout the cell which the second type network devices use in handover measurements, or, alternatively, a signal broadcasted throughout the cell which the second type network devices use to trigger sending of a handover measurement report to the network. Furthermore, the pilot signal may be a signal broadcasted throughout the cell which the second type network devices use in idle mode cell selection or re-selection measurements, or, alternatively, a signal broadcasted throughout the cell

30  
35

which the second type network devices use to trigger an idle mode cell selection or re-selection.

The pilot signal may be a Common Pilot Channel (CPICH),  
5 which is available in UMTS WCDMA FDD air-interface specified by the 3<sup>rd</sup> Generation Partnership Project 3GPP.

For the decision, statistical information of call  
connections may be used. The statistical information may  
10 include information about unsuccessful calls.  
Unsuccessful calls may include blocked or dropped calls, or calls having an insufficient quality, e.g., calls with reduced bit rates and the like. Furthermore, also a call in which excessive packet re-transmissions occur may be  
15 considered as an unsuccessful call. The information about unsuccessful calls may include statistics on dropped calls and decreased bit rates on real time or packet calls.

20 Furthermore, for the decision main resource specific information may be used. The main resource specific information may include information about the used and available transmission power of the first type network device and/or about used and available hardware resources  
25 of the first type network device.

The main resource specific information may include information about used and available logical resources. In particular, the logical resources may include a  
30 channelization code from a pool of channelization codes.

The attractiveness information may be included in the parameters which the second type network devices use to trigger sending of a handover measurement report to the  
35 network, or, alternatively, may be included in the

parameters which the second type network devices use to trigger a cell selection or re-selection.

5 The first type network device may be a base station, and the second type network device may be a mobile station.

The method may be performed for a plurality of cells and the attractiveness information for each cell is set by taking into account the downlink load on the other cells.  
10

Thus, by taking into account the neighbouring cells and by controlling also the attractiveness information in the neighbouring cells, the distribution can be made more evenly.  
15

Hence, according to the invention the network capacity as a whole is increased by balancing the loading between the cells. The network can automatically respond to load distribution varying over a short time.  
20

#### BRIEF DESCRIPTION OF THE DRAWINGS

The present invention will be more readily understood with reference to the accompanying drawings in which:  
25

Fig. 1 shows a diagram wherein the influence of the pilot power level on the area of a base station cell is illustrated,  
30

Fig. 2 shows a flowchart illustrating a procedure according to a first embodiment,

Fig. 3 shows a network system consisting of three cells wherein the procedure according to the invention is applied, and

5 Fig. 4 shows a diagram in which the effect of the procedure according to the invention on the service probability is illustrated in a case where the capacity is predominantly limited by the DL channelization codes in a WCDMA system.

10

#### DETAILED DESCRIPTION OF PREFERRED EMBODIMENTS

In the following, preferred embodiments of the invention  
15 is described in more detail with reference to the accompanying drawings.

According to the first embodiment, a procedure is provided to automatically increase the total performance  
20 (capacity) of a mobile phone network with an algorithm that is autotuning the power level of the pilot signals in the network base stations. In this way, a base station is made more or less attractive for mobiles. That is, the number of served users in a cell can be varied.

25

The pilot signal is a signal provided by each base station, which carries a bit sequence or code known by the mobile stations. The bit sequence can be base station and sector dependent. The received power level of the  
30 pilot signal is used by the mobile stations to measure the relative distance between different base stations that could be used for communication. Thus, the power level of the pilot signal of a base station determines, how far a mobile can 'hear' the base station signal. In  
35 WCDMA (Wideband Code Division Multiple Access) the cell

selection, re-selection and the selection of the active set of cells which are used for communication is based on the relative strength of received pilot power (CPICH  $E_c/I_o$ , wherein  $E_c/I_o$  = chip energy to total interference spectral density) from different cells. Thus, the borders of a cell are determined by the relative strength of the received pilot signal from different cells.

Hence, by changing the pilot power level, the area of the base station cells can be changed. This illustrated in Fig. 1(a) and 1(b). In Fig. 1(a), a high pilot power is set in the Common Pilot Channel, leading to a large area of the cell. In this cell, mobile stations MS1 to MS12 are served by the base station BS. On the other hand, in Fig. 1(b), a low pilot power level is set, leading to a small area of the cell. Thus, in Fig. 1(b) the numbers of served mobile stations is reduced. In detail, the mobile stations MS1, MS3, MS8, MS9, MS10, and MS12 are now outside the cell area and not served by the BS anymore. Hence, the load on the BS is decreased.

Thus, according to the first embodiment, the power level of the pilot signal is used as an information whether a particular base station is the most attractive for a particular mobile station or not.

In the flow chart of Fig. 2, the procedure according to the first embodiment is illustrated.

In step 1, information about the load of the cell is detected. In step 2, an evaluation of the detected load is made. That is, the load is evaluated and it is decided whether the particular base station is optimal to provide a sufficient service to the mobile stations which request service from the base stations. For example, it is

decided whether the load is too high. This decision can be made based on different algorithms. According to the first embodiment, statistical information is used, as will be described in the following.

5

In step 3, the power level is adjusted based on the evaluation step. That is, in case it is decided that the load in the cell is too high, the pilot power level is reduced such that the cell area is reduced. On the other hand, in case it is decided that the load in the cell is low, the pilot power may be increased such that the cell area is increased. This may be effected in case the load in one or more neighbouring cells is higher than in the particular cell.

15

Since the pilot power level set in the Common Pilot Channel CPICH of the base station is provided automatically to the mobile stations in the transmission range, the mobile stations are immediately informed whether they should further use the particular base station (namely, in case they receive a sufficient high power level) or whether they should move to another cell (namely, in case they receive a too low power level).

25 Next, the above described detecting step 1 and the evaluation step 2 are described in more detail.

According to the first embodiment, the pilot power levels are determined by available statistics.

30

In detail, the algorithm according to the first embodiment is based on the statistics of unsuccessful calls (MS-BTS-connections) or unsuccessful call attempts due to load reasons.

35

In this context, an unsuccessful call may include

- a) blocked calls (i.e., calls which can not be initiated),
- b) dropped calls (i.e, calls which are terminated during the call),
- c) bad quality calls (too high BER (Bit Error Rate) or BLER),
- d) reduced bit rates of non-realtime calls or multirate realtime calls (the latter does not only include data calls, but also calls via an AMR (Adaptive Multirate) speech codec),
- e) excessive re-transmissions of data packets, and the like.

Thus, this algorithm is based on statistics of calls which are terminated or distorted due to network limitations. The advantage of the algorithm is, it reacts directly on what has to be avoided as much as possible - unsuccessful call (attempts). Although in this case it has to be put up with that the algorithm starts acting only if at least one call was dropped (i.e., that the first drop(s) cannot be prevented), this algorithm provides a simple procedure for detecting the load and to decide the pilot power level.

In detail, the network control element checks in the detecting step whether there are any unsuccessful calls . Thus, if the network control elements detects that there are too many unsuccessful calls due to load reasons, it lowers the pilot power level. By this measure, the area of the cell is reduced. Correspondingly, mobile stations located at the border of the cell (before the pilot power level was lowered) do not select the base station of this cell, since in WCDMA the cell section is made based on the relative strength of received pilot power (CPICH

Ec/Io). Hence, the number of mobile stations trying to connect to the base station is reduced.

Preferably, the network control element performs the procedure for a plurality of neighbouring cells. That is, the autotuning algorithm according to the first embodiment is executed based on the comparison of a cell's performance with its neighbouring cells' performance. Thus, the network control element can adjust the pilot power level in each of the cells such that a balanced load on all cells (i.e., on all base stations) is achieved.

That is, if the additionally needed capacity is not available in one cell but in a neighbouring cell (or the neighbour of a neighbour), the adjustment of base station pilot powers can make different loading of cells more equal: Large and highly loaded cells are made smaller by lowering their pilot power level and small and low loaded cells are made larger by increasing their pilot power (also see Fig. 1). This happens because the cell borders are determined by the relative strength of the received pilot signal from different cells.

By automatically determining if a cell is large, i.e. heavily loaded compared to its surrounding neighbours, the pilot power of the cell can be adjusted to more evenly distribute network load.

This is illustrated in Fig. 3, in which a three base stations BS1 to BS3 serve three cells C1 to C3, respectively. The areas of the cells are idealized as hexagons. The cell borders before performing any pilot power changes are indicated by a continuous line. The base stations are controlled (in this example) by a RNC



(Radio Network Controller). Now, it is assumed that cell C2 has a heavy load, for example due to a sports event in its area. Thus, the RNC checks the load situations in this cell C2 and also in the neighbouring cells C1 and C3. In this case, the RNC detects that the load on the cells C1 and C3 is small, whereas the load on the cell C2 is large. Hence, the pilot power level in cell C2 is reduced, and the pilot power levels in cells C1 and C3 can be increased. The resulting areas of the cells are indicated by dotted lines. Hence, the cells C1 and C3 can serve mobile stations which had to be served in cell C2 before a pilot power change. In this way, a more distributed load in the network is achieved.

Thus, by automatically determining if a cell is large, i.e. heavily loaded compared to its surrounding neighbours, the pilot power of the cell can be adjusted to more evenly distribute network load.

Hence, the network can automatically respond to load distribution varying over a short time (within a few hours or minutes, or even seconds). Temporary 'hotspots' (e.g. sport events) are better served.

Next, a second embodiment is described. According to this embodiment, basically the same procedure as according to the first embodiment is performed. However, the detection step and the deciding step are performed in a different way.

Namely, according to the second embodiment, the pilot power levels are determined by main resource specific measures. The main resource specific measures concern used power resources and/or used hardware resources and/or used logical resources of the base station BS. The

used power resources are the used base station transmitting (BS Tx) total power. The used hardware resources can be examined by comparing the used hardware resource with the available hardware resource. That is, for example the percentage of the used hardware resource with respect to the total available hardware resources can be determined. By this measure, the load measured based on the hardware resources can easily be compared with the hardware resources in other base stations which might have different available hardware resources.

The logical resources include information on used channelization code resources of the base station, or one sector controlled by the base station. Namely, the channelization code resources consist of codes taken from a set of orthogonal codes (code tree) and there is a limited amount of orthogonal codes available at each base station or a sector controlled by the base station. For example, the information of logical resources may include the utilisation of the code tree (trees in case of multiple scrambling codes) in a base station. This is, e.g., important in WCDMA, as it is reflecting how many downlink (DL) channelization codes there are left.

The determination whether the load is too high or too low compared to neighbours can be made by a comparison with predetermined target loads or the like.

However, more preferably the procedure according to the second embodiment is used in the situation in which a plurality of cells are controlled in order to obtain a more distributed load in the network.

That is, if in either of the hardware resources there is a big difference between a cell and its neighbours it is

checked whether some of the low loaded cells could be made higher loaded and some of the high loaded cells could be made lower loaded. If this is the case, the CPICH power of the highly loaded cells are adjusted smaller and the CPICH power of the low loaded cells are adjusted bigger.

Fig. 4 shows a diagram in which the effect of the procedure according to the invention on the service probability is illustrated in a case where the capacity is predominantly limited by the DL channelization codes in a WCDMA system. From the diagram shown in Fig. 4, the increase in capacity (= number of served users) after a few iterations with an autotuning algorithm according to the first or second embodiment is derivable.

In particular, on the x-axis the number of iterations (i.e., the number of times in which the pilot power level was changed) is plotted, whereas on the y-axis the service probability is plotted in percent. The data was obtained from a WCDMA network simulator. The network itself was an urban area (micro cell network) providing only speech services with 12.2 kbits/s. Thus, the limiting factor was the absolute number of available downlink channelization codes.

The diagram of Fig. 4 shows a significant increase of service probability from initially 87% when all base station pilot powers had the same level up to finally 95% when the autotuning algorithm had adjusted the base station pilot powers to maximise the network capacity.

It is noted that no additional hardware was necessary for this capacity improvement.

35

It is noted that the algorithm according to the  
embodiments does not have any uplink measurements or  
parameters as input. Thus, the procedure can be performed  
easily without the need of complicated additional  
5 hardware. Nevertheless, preferably, it should be ensured  
that the downlink (DL) power is not set to a too low  
level such that the situation is not optimal from an  
uplink (UL) point of view. That is, when changing the  
relative DL powers of neighbouring cells, it should be  
10 ensured that handover still works.

The invention is not limited to the embodiments described  
above. Various amendments and modifications within the  
scope of the appended claims are possible.

15 In particular, the embodiments may be combined. Thus, a  
more refined determination of the pilot power levels is  
possible.

20 Moreover, the algorithm can be modified. For example,  
also the history of load on the cell can be taken into  
account. That is, in case large changes in the load in  
comparison to the average load occur, the pilot power  
level can be changed correspondingly.

25 The RNC as a network control device is only an example.  
For example, the network control element in which the  
above automatic controlling function operates may be a  
CSCF (Call State Control Function), or an NMS (Network  
30 Management System) or another suitable device.

Moreover, the statistics described above in connection  
with the first embodiment may be collected by PI's  
(Performance Indicators).

35

The method according to the invention is designed for WCDMA but it could be considered also for GSM. Moreover, the method according to the invention can also be used in any cellular radio network where mobile get information  
5 about attractiveness of the cell.

The power level of a pilot signal was given as an example for the attractiveness information. However, the attractiveness information may be provided in a different  
10 form. For example, the attractiveness information may be included in the parameters which the mobile stations use to trigger sending of a handover measurement report to the network. Alternatively, the attractiveness information may be included in the parameters which the  
15 mobile stations use to trigger a cell selection or re-selection.

One example of the parameters are the cell individual offsets known from the UMTS idle mode control and radio  
20 resource control procedures. By using these, the MS can be directly enforced to prefer some cells over other cells when it makes the measurements for triggering of a cell selection, re-selection or handover.

25

**Claims**

1. A method for controlling a network comprising at  
5 least one cell by a first type network device, wherein  
the first type network device is adapted to serve second  
type network devices, the method comprising the steps of  
detecting (S1) the downlink load of the cell in a  
10 direction from the first type network device to the  
second type network device,  
deciding (S2) whether the first type network device  
serving the cell is suited to serve sufficient service to  
second type network devices requesting service in the  
cell with respect to the detected downlink load,  
15 generating (S3) information as to the attractiveness  
of the first type network device based on the result of  
the deciding step, and  
providing the information to the second type network  
devices.  
20
2. The method according to claim 1, wherein the  
deciding step comprises the step of  
comparing the downlink load in the cell with the  
downlink load in at least one neighbouring cell,  
25 wherein in the attractiveness information generating  
step, the attractiveness information is set based on the  
comparison.
3. The method according to claim 2, wherein in case the  
30 comparing step results in that the load of the cell is  
higher than in the neighbouring cell, the attractiveness  
information is set such that the area in which second  
type network devices are served in the cell is set  
smaller.

35

4. The method according to claim 2, wherein in case the comparing step results in that the load of the cell is smaller than in the neighbouring cell, the attractiveness information is set such that the area in which second  
5 type network devices are served in the cell is set larger.
5. The method according to claim 1, wherein the attractiveness information is the power level of a pilot  
10 signal.
6. The method according to claim 5, wherein the pilot signal is a signal broadcasted throughout the cell which the second type network devices use in handover  
15 measurements.
7. The method according to claim 5, wherein the pilot signal is a signal broadcasted throughout the cell which the second type network devices use in idle mode cell  
20 selection or re-selection measurements.
8. The method according to claim 5, wherein the pilot signal is a signal broadcasted throughout the cell which the second type network devices use to trigger sending of  
25 a handover measurement report to the network.
9. The method according to claim 5, wherein the pilot signal is a signal broadcasted throughout the cell which the second type network devices use to trigger an idle  
30 mode cell selection or re-selection.
10. The method according to claim 5, wherein the pilot signal is a Common Pilot Channel (CPICH).

11. The method according to claim 1 or 2, wherein in the deciding step statistical information of call connections are used.
- 5 12. The method according to claim 11, wherein the statistical information include information about unsuccessful calls.
- 10 13. The method according to claim 11, wherein the statistical information include information about call blocking.
- 15 14. The method according to claim 11, wherein the statistical information include information about bitrates of calls.
- 20 15. The method according to claim 1 or 2, wherein in the deciding step main resource specific information are used.
- 25 16. The method according to claim 15, wherein the main resource specific information include information about the used and available transmission power of the first type network device.
- 30 17. The method according to claim 15, wherein the main resource specific information include information about used and available hardware resources of the first type network device.
- 35 18. The method according to claim 15, wherein the main resource specific information include information about used and available logical resources of the first type network device.



19. The method according to claim 18, wherein the logical resources include a channelization code from a pool of channelization codes.

5 20. The method according to claim 1, wherein the first type network device is a base station.

21. The method according to claim 1, wherein the second type network device is a mobile station.

10

22. The method according to claim 1, wherein the method is performed for a plurality of cells (C1, C2, C3) and the attractiveness information for each cell is set by taking into account the downlink load on the other cells.

15

23. The method according to claim 1, wherein the attractiveness information is included in the parameters which the second type network devices use to trigger sending of a handover measurement report to the network.

20

24. The method according to claim 1, wherein the attractiveness information is included in the parameters which the second type network devices use to trigger a cell selection or re-selection.

25

25. A network control device in a network comprising at least one cell served by a first type network device, wherein the first type network device is adapted to serve second type network devices, wherein the network control device is further adapted

30

to detect downlink load of the cell in a direction from the first type network device to the second type network device, to decide whether the first type network device serving the cell is suited to serve sufficient

35

service to second type network devices requesting service

in the cell with respect to the detected downlink load,  
to generate information as to the attractiveness of the  
first type network device based on the result of the  
deciding step, and to provide the information to the  
5 second type network devices.

26. The network control device according to claim 25,  
wherein the network control device is further adapted to  
compare the downlink load in the cell with the downlink  
10 load in at least one neighbouring cell,  
wherein the attractiveness information is set based  
on the comparison.

27. The network control device according to claim 26,  
15 wherein the network control element is adapted to set the  
attractiveness information set such that the area in  
which second type network devices are served in the cell  
is set smaller in case the comparison results in that the  
load of the cell is higher than in the neighbouring cell.

20 28. The network control device according to claim 26,  
wherein the network control element is adapted to set the  
attractiveness information set such that the area in  
which second type network devices are served in the cell  
25 is set larger in case the comparison results in that the  
load of the cell is lower than in the neighbouring cell.

29. The network control device according to claim 25,  
wherein the attractiveness information is the power level  
30 of a pilot signal.

30. The network control device according to claim 29,  
wherein the pilot signal is a signal broadcasted  
throughout the cell which the second type network devices  
35 use in handover measurement.

31. The network control device according to claim 29,  
wherein the pilot signal is a signal broadcasted  
throughout the cell which the second type network devices  
5 use in idle mode cell selection or re-selection  
measurements.

32. The network control device according to claim 29,  
wherein the pilot signal is a signal broadcasted  
10 throughout the cell which the second type network devices  
use to trigger sending of a handover measurement report  
to the network.

33. The network control device according to claim 29,  
15 wherein the pilot signal is a signal broadcasted  
throughout the cell which the second type network devices  
use to trigger an idle mode cell selection or re-  
selection.

20 34. The network control device according to claim 29,  
wherein the pilot signal is a Common Pilot Channel  
(CPICH).

35. The network control device according to claim 25 or  
25 26, wherein the network control device is adapted to use  
statistical information about call connections in order  
to detect the downlink load on the cell.

36. The network control device according to claim 35,  
30 wherein the statistical information include information  
about unsuccessful calls.

37. The network control device according to claim 35,  
wherein the statistical information include information  
35 about call blocking.

38. The network control device according to claim 35, wherein the statistical information include information about bitrates of calls.

5

39. The network control device according to claim 25 or 26, wherein the network control device is adapted to use main resource specific information in order to detect the downlink load on the cell.

10

40. The network control device according to claim 39, wherein the main resource specific information include information about the used and available transmission power of the first type network device.

15

41. The network control device according to claim 39, wherein the main resource specific information include information about used and available hardware resources of the first type network device.

20

42. The network control device according to claim 39, wherein the main resource specific information include information about used and available logical resources of the first type network device.

25

43. The network control device according to claim 42, wherein the logical resources include a channelization code from a pool of channelization codes.

30

44. The network control device according to claim 25, wherein the first type network device is a base station.

45. The network control device according to claim 25, wherein the second type network device is a mobile station.

35

46. The network control device according to claim 25,  
wherein the network control device is adapted to control  
a plurality of cells (C1, C2, C3) and to set the  
5 availability information for each cell by taking into  
account the downlink load on the other cells.

47. The network control device according to claim 25,  
wherein the attractiveness information is included in the  
10 parameters which the second type network devices use to  
trigger sending of a handover measurement report to the  
network.

48. The network control device according to claim 25,  
15 wherein the attractiveness information is included in the  
parameters which the second type network devices use to  
trigger a cell selection or re-selection.

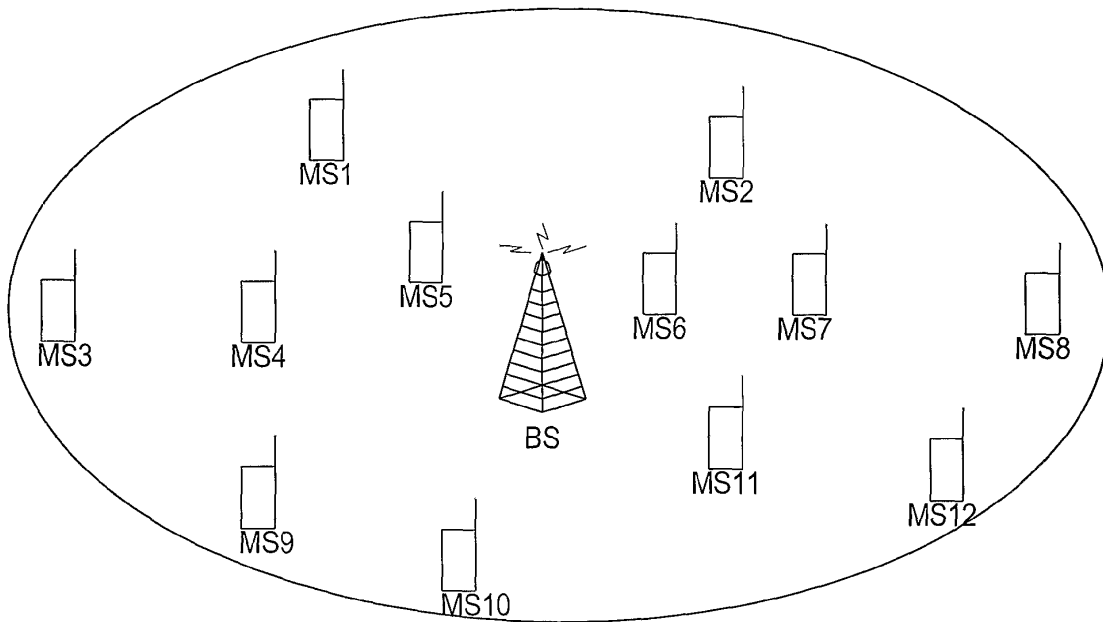


Fig. 1(a)

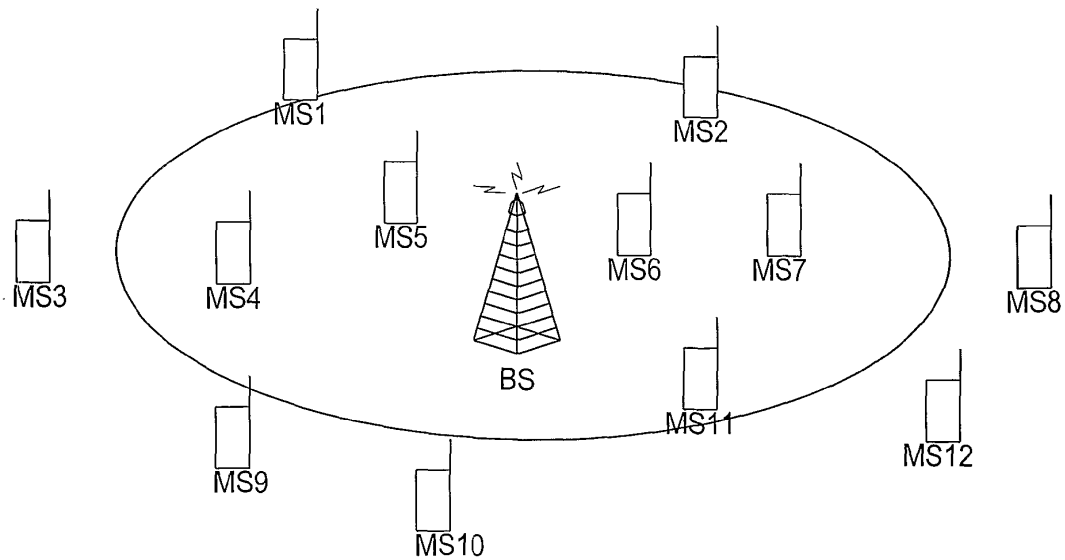


Fig. 1(b)

Fig. 2

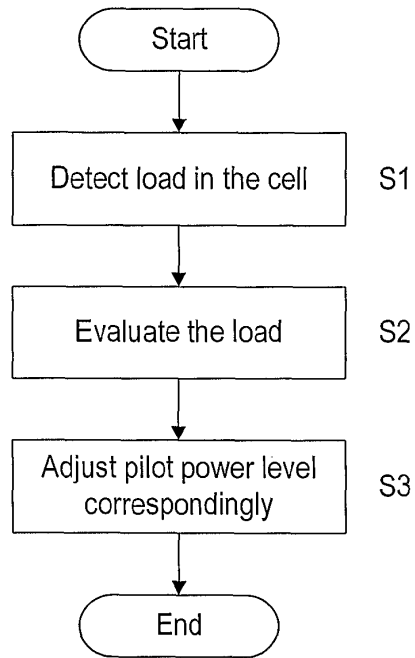
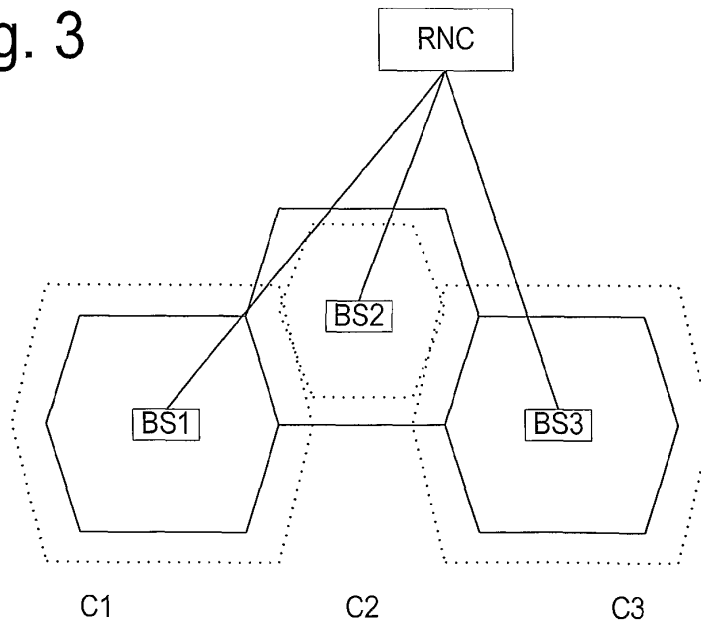


Fig. 3



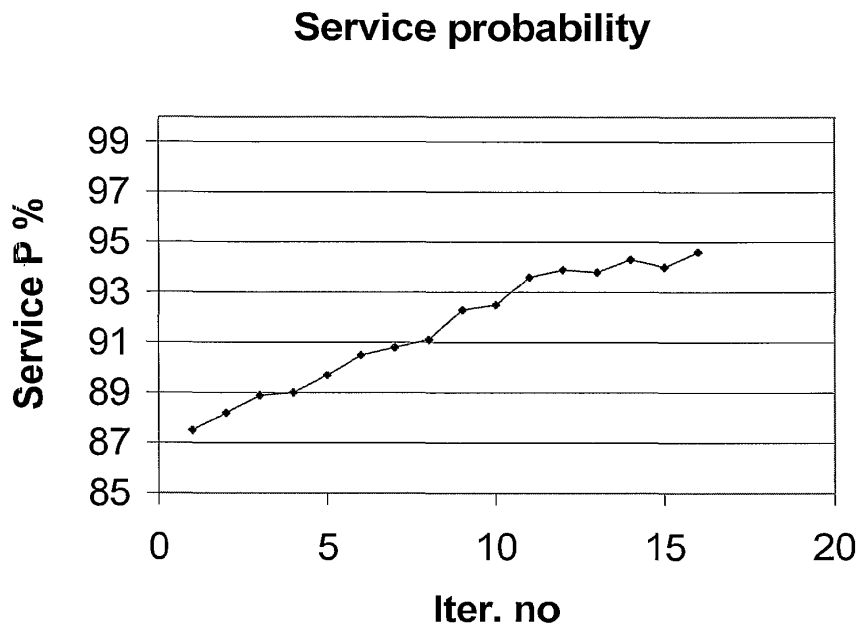


Fig. 4



INTERNATIONAL SEARCH REPORT

International Application No  
PCT/EP 01/03985

| <b>A. CLASSIFICATION OF SUBJECT MATTER</b><br>IPC 7 H04Q7/36  |  |   |
|---|--|---|
| According to International Patent Classification (IPC) or to both national classification and IPC   |  |   |
| <b>B. FIELDS SEARCHED</b><br>Minimum documentation searched (classification system followed by classification symbols)<br>IPC 7 H04Q  |  |   |
| Documentation searched other than minimum documentation to the extent that such documents are included in the fields searched   |  |   |
| Electronic data base consulted during the international search (name of data base and, where practical, search terms used)<br>EPO-Internal  |  |   |
| <b>C. DOCUMENTS CONSIDERED TO BE RELEVANT</b>   |  |   |
| Category °  | Citation of document, with indication, where appropriate, of the relevant passages   | Relevant to claim No.   |
| X   | US 5 898 682 A (KANAI TOSHIHITO)<br>27 April 1999 (1999-04-27)<br><br>column 1, line 50 -column 2, line 52<br>column 5, line 33 -column 10, line 5;<br>figures   | 1-10, 14,<br>20-34,<br>38, 44-48  |
| X   | WO 97 08909 A (HAEMAELAEINEN SEPPO ;NOKIA<br>TELECOMMUNICATIONS OY (FI); GRANLUND SE)<br>6 March 1997 (1997-03-06)<br><br>page 4, line 4 -page 5, line 9<br>page 6, line 7 -page 7, line 29<br>page 8, line 12 -page 12, line 30 | 1-3,<br>5-10,<br>20-27,<br>29-34,<br>44-46  |
| <input type="checkbox"/> Further documents are listed in the continuation of box C. <input checked="" type="checkbox"/> Patent family members are listed in annex.  |  |   |
| ° Special categories of cited documents :   |  |   |
| *A* document defining the general state of the art which is not considered to be of particular relevance<br>*E* earlier document but published on or after the international filing date<br>*L* document which may throw doubts on priority claim(s) or which is cited to establish the publication date of another citation or other special reason (as specified)<br>*O* document referring to an oral disclosure, use, exhibition or other means<br>*P* document published prior to the international filing date but later than the priority date claimed |  | *T* later document published after the international filing date or priority date and not in conflict with the application but cited to understand the principle or theory underlying the invention<br>*X* document of particular relevance; the claimed invention cannot be considered novel or cannot be considered to involve an inventive step when the document is taken alone<br>*Y* document of particular relevance; the claimed invention cannot be considered to involve an inventive step when the document is combined with one or more other such documents, such combination being obvious to a person skilled in the art.<br>*&* document member of the same patent family |
| Date of the actual completion of the international search<br><br>21 December 2001   |  | Date of mailing of the international search report<br><br>03/01/2002  |
| Name and mailing address of the ISA<br>European Patent Office, P.B. 5818 Patentlaan 2<br>NL - 2280 HV Rijswijk<br>Tel. (+31-70) 340-2040, Tx. 31 651 epo nl,<br>Fax: (+31-70) 340-3016  |  | Authorized officer<br><br>Tsapelis, A   |

INTERNATIONAL SEARCH REPORT

Information on patent family members

International Application No  
PCT/EP 01/03985

| Patent document cited in search report |   | Publication date | Patent family member(s) | Publication date |
|--|---|------------------|-------------------------|------------------|
| US 5898682                             | A | 27-04-1999       | JP 2803716 B2           | 24-09-1998       |
|  |   |                  | JP 9247085 A            | 19-09-1997       |
|  |   |                  | AU 721201 B2            | 29-06-2000       |
|  |   |                  | AU 1518997 A            | 18-09-1997       |
|  |   |                  | GB 2350024 A ,B         | 15-11-2000       |
|  |   |                  | GB 2350026 A ,B         | 15-11-2000       |
|  |   |                  | GB 2311191 A ,B         | 17-09-1997       |
| -----                                  |   |                  |                         |                  |
| WO 9708909                             | A | 06-03-1997       | WO 9708909 A1           | 06-03-1997       |
|  |   |                  | AU 3260495 A            | 19-03-1997       |
| -----                                  |   |                  |                         |                  |

(12) INTERNATIONAL APPLICATION PUBLISHED UNDER THE PATENT COOPERATION TREATY (PCT)

(19) World Intellectual Property Organization  
International Bureau



(43) International Publication Date  
15 March 2001 (15.03.2001)

PCT

(10) International Publication Number  
**WO 01/19102 A1**

(51) International Patent Classification<sup>7</sup>: **H04Q 7/22**,  
H04L 29/06

Frank [DE/DE]; Siechenmarschstr. 11a, D-33615 Bielefeld (DE). **HOYLER, Stefan** [DE/DE]; Voedestr. 80, D-44866 Bochum (DE).

(21) International Application Number: PCT/EP00/08521

(22) International Filing Date: 31 August 2000 (31.08.2000)

(74) Agents: **JEFFERY, Kendra** et al.; Nokia IPR Department, Nokia House, Summit Avenue, Farnborough, Hampshire GU14 0NG (GB).

(25) Filing Language: English

(26) Publication Language: English

(30) Priority Data:  
9920681.5 2 September 1999 (02.09.1999) GB  
9927354.2 19 November 1999 (19.11.1999) GB

(81) Designated States (*national*): AE, AG, AL, AM, AT, AU, AZ, BA, BB, BG, BR, BY, BZ, CA, CH, CN, CR, CU, CZ, DE, DK, DM, DZ, EE, ES, FI, GB, GD, GE, GH, GM, HR, HU, ID, IL, IN, IS, JP, KE, KG, KP, KR, KZ, LC, LK, LR, LS, LT, LU, LV, MA, MD, MG, MK, MN, MW, MX, MZ, NO, NZ, PL, PT, RO, RU, SD, SE, SG, SI, SK, SL, TJ, TM, TR, TT, TZ, UA, UG, US, UZ, VN, YU, ZA, ZW.

(71) Applicant (*for all designated States except US*): **NOKIA MOBILE PHONES LIMITED** [FI/FI]; Keilalahdentie 4, FIN-02150 Espoo (FI).

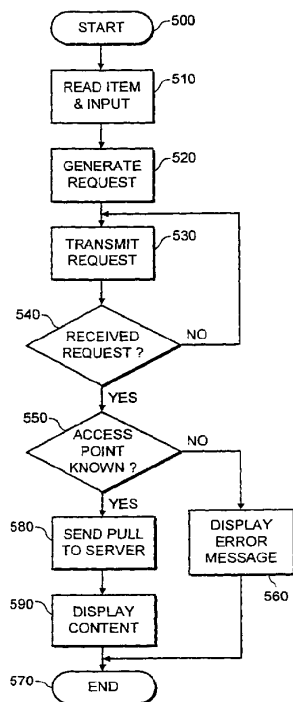
(84) Designated States (*regional*): ARIPO patent (GH, GM, KE, LS, MW, MZ, SD, SL, SZ, TZ, UG, ZW), Eurasian patent (AM, AZ, BY, KG, KZ, MD, RU, TJ, TM), European patent (AT, BE, CH, CY, DE, DK, ES, FI, FR, GB, GR, IE,

(72) Inventors; and

(75) Inventors/Applicants (*for US only*): **ZILLIKENS**,

[Continued on next page]

(54) Title: A WIRELESS COMMUNICATION TERMINAL FOR ACCESSING LOCATION INFORMATION FROM A SERVER



(57) Abstract: A system (301), a method, and a wireless communication terminal (1, 300) for accessing location information from at least one server (320-340). The terminal (1, 300) comprising a receiver and a transmitter (19) arranged to receive and transmit data packets from/to at least one server (320-340) comprising location means, through a wireless communication network (310) connected to linking means (360). The linking means (360) is arranged to forward the data packets between the terminal (1, 300) and the server (320-340). A memory (17a, 17b) is also provided in the terminal (1, 300), which comprises at least one item, which is provided with an access point which indicates the site of the server (320-340) to be accessed, wherein the server (320-340) is accessed by sending a request through the wireless communication network (310) as a data packet comprising the access point to the linking means (360) to access and receive content from the server (320-340). A browser application (20) is arranged in the terminal (1, 300), to establish a session to the linking means (360).

WO 01/19102 A1



IT, LU, MC, NL, PT, SE), OAPI patent (BF, BJ, CF, CG, CI, CM, GA, GN, GW, ML, MR, NE, SN, TD, TG).

*For two-letter codes and other abbreviations, refer to the "Guidance Notes on Codes and Abbreviations" appearing at the beginning of each regular issue of the PCT Gazette.*

**Published:**

— *With international search report.*

A wireless communication terminal for accessing location information from a server.

The invention relates to a method, terminal and system for providing location  
5 information from a server to a wireless communication terminal.

There are many ways of determine positions, for example the position of a car  
can be determined by means of so called car navigation systems. These kind  
of navigation systems may comprise a satellite receiver connected to  
10 processing means and a mobile phone. The satellite receiver, e.g. a global  
position system (GPS) receiver, is able to receive signals giving an indication  
of the position of the receiver, i.e. in this case the car. The received signals  
can then be processed by the processing means, and sent by the mobile  
phone as a request to a server. The server can be provided with a location  
15 database comprising e.g. digitised maps, and is able to respond to the  
request. The respond can then be processed by the processing means, and  
can for example be shown as a digitised map on a display. In this way it will  
be possible to obtain location information, which is dependent on the position  
of the car.

20

One example on a navigation system is known from WO96/11381, which  
describes a navigation device for people. The device comprising a navigation  
unit which has a receiver device for the wireless transmission of data for  
detecting the current geographical position. It is possible to provide an input  
25 unit, in particular for the input of a target position. The result of this input is  
presented by an output unit, in particular for the output of path guiding data.  
To process the all data, the device further comprising a computer, in particular  
for route planning. The computer comprises a memory with a digitised road  
map and can be connected for data transmission to the navigation unit via a  
30 communication unit. The navigation unit, the communication unit, the input

2

unit and the output unit form a portable hardware unit. The communication unit comprising a transmitter-receiver for the wireless transmission of route data between the computer and the portable unit.

5 Another example of a navigation system is disclosed in WO 96/07110, which describes a navigation information system comprises a communications system having a fixed part and a mobile part. The fixed part including a data storage and processing means for identifying the location of a mobile unit, generating guidance information appropriate to that location and transmitting it  
10 to the mobile unit. The user makes a request for guidance information, and the system, having determined the user's present location, then transmits instructions to the user. The user's present location can be determined by means such as a Satellite Positioning System.

15 An alternative way of measuring the position in a navigation system by satellite receivers, is shown in for example EP-A2-0753978, which describes a process for directing a subscriber toward a destination within an SDMA (Space Division Multiple Access) mobile radio network, and a processor controlled station control. The station control contains a communications  
20 interface unit for receiving a message that specifies a destination desired by a subscriber, and a microprocessor which determines the current location of the subscriber by evaluating directional and distance information. The station control furthermore contains communications interface unit, whereby it retrieves information from a data base, which defines a route from the location  
25 to the destination. This information is transmitted in summary form to the subscriber's mobile radio terminal.

However, all these navigation systems mentioned above, is all dependant of the location of the user. This means that the user who requests a service from  
30 a service provider, e.g. a request of traffic information, should include its

3

present position. This is a major drawback, since this in some cases requires additional equipment, which can be rather expensive. Furthermore, the user has to convert the positioning information into a prescribed format, and send the positioning information to the server together with the service request.

5 This way is difficult to have cooperation with different service providers which can demand different types of formats.

Also, even the user uses a cellular position process as disclosed in EP-A2-0753978, this requires that the user disclose his actual position to the service  
10 provider. This means that the user must reveal his position, which is a major security hazard, if you are not sure about the trustworthiness of the service provider. For example, when the request is processed at the server, a hacker could more easily find out that where you are, or even worse include a virus in the response back to the terminal. Also, upon sending the actual position of  
15 the user, it will occupy a lot of space in the traffic on the wireless network, since data transmissions on a wireless network normally has a very narrow bandwidth.

Furthermore, in WO99/27742 a telecommunication system is disclosed, which  
20 uses a terminal based browser within a mobile phone to connect the phone to web-based location services and to a Mobile Positioning Centre (MPC). The browser is able to present graphical information, which permits the user of the mobile phone to determine the present location of the mobile phone. The browser is also able to communicate with a location services node, through a  
25 cellular network. To obtain the present location of the phone, the browser first sends a positioning request and format information associated with the positioning request to the location services node. Thereafter, the MPC receives the request from the location services node, and determine the phones coordinate location. The information about the location of the phone is  
30 then forwarded back to the phone and presented on the browser. However,

4

as disclosed in EP-A2-0753978, this requires that the user must disclose his actual position to the service provider, which means that the user must reveal his position, which is a major security hazard.

- 5 Therefore, there is a significant need for a wireless communication terminal to receive location information from a server more efficiently, which has a increased level of security. Also, it would be advantageous to avoid transmission of unnecessary position information. Yet another need is to have one single format for position information, which is independent of the format  
10 required by the service provider, in order to facilitate the use of different positioning tools.

In accordance with an aspect of the present invention there is provided a wireless communication terminal for accessing location information from a  
15 server. The terminal comprising a receiver and a transmitter arranged to receive and transmit data packets from/to at least one server comprising location means, through a wireless communication network connected to linking means. The linking means is arranged to forward the data packets between the terminal and the server. A memory is also provided in the  
20 terminal, which comprises at least one item, which is provided with an access point which indicates the site of the server to be accessed, wherein the server is accessed by sending a request through the wireless communication network as a data packet comprising the access point to the linking means to access and receive content from the server. A browser application is arranged  
25 in the terminal, to establish a session to the linking means by reading the item from the memory, enable the transmitter to send the request as a data packet through the linking means to the server, and handle received content by means of the receiver. A user interface connected to the browser application having display means for displaying content received from the  
30 server and user input means to provide an input to the browser application.



5

The input comprising a query of location information, which is independent of the position of the terminal, wherein the input is provided in the request, and arranged to receive content comprising an indication of the location information from said server by means of the location means.

5

Hence, the basic idea of the invention is to provide a request from a wireless communication terminal, like a cellular phone, for accessing location information from a server comprising location information, which is independent of the position of the terminal. This means that the terminal  
10 sends a request to the server for receiving an indication of location information, without revealing the position of the terminal upon sending the request to the server. As an example, the present invention can be implemented in a Wireless Application Protocol Architecture (WAP) environment. The Wireless Application Protocol (WAP) is a result of  
15 continuous work to define an industry wide standard for developing applications over cellular communication networks. This makes it possible to access for example the Internet or other kinds of information networks provided with hypermedia servers, from an ordinary cellular phone supporting WAP. These types of cellular phones which supports WAP, have only a small  
20 fraction of the resources of a typical desktop or portable computer. This means that the features in the phone are very limited compared to a computer. The reason for this limitation is the size of the phones, i.e. the phone has a severe limitation in processing power, memory space, display size and buttons or keys by which a user can request, view and manipulate  
25 information obtained from a hypermedia server. Therefore, it is very important that the features in the phone are made as efficient as possible. Also, the relatively high cost for a call from a cellular phone makes it also very important to provide the client with a fast response from the server.

6

A particular advantageous embodiment, is that the terminal can also be provided with position means, to determine position information of the terminal, and optionally send the positioning information to the server, either when requested from the server or in the request sent to the server, in order to give an indication of the position of the terminal. Thus, it is the user who controls the information sent between the terminal and the server, since it is optional. Also, this will provide a high degree of freedom for the user, to choose between different alternatives, by making a choice if any position information should be sent to the server.

10

Further advantages according to the present invention will be apparent from the dependent claims.

The invention will be described in greater detail in the following by way of example only and with reference to the attached drawings, in which

- Fig.1            schematically illustrates a preferred embodiment of a hand portable phone according to the present invention,
- 20 Fig. 2            schematically shows the essential parts of a telephone for communicating with a cellular or cordless network,
- Fig. 3            schematically shows a connection between a communication terminal and different servers in a network, according to a preferred embodiment according to the present invention, and
- 25 Fig. 4            shows a flowchart over a method for receiving location information from a server to a cellular telecommunication terminal, according to the present invention.

30

7

Fig. 5a-b shows an example of a user interface in a phone according to the present invention.

5 Fig. 6 shows a an example of the transmitted messages between a communication terminal, a network server and a gateway according to the invention

Fig. 1 shows a preferred embodiment of a wireless communication terminal, hereafter also referred to as a phone, according to the present invention. The phone, which is generally designated by 1, comprises a user interface having a keypad 2, a display 3, an on/off button 4, a speaker 5, and a microphone 6. The phone 1 according to the preferred embodiment is adapted for communication via a wireless telecommunication network, e.g. a wireless network. However, the phone could also have been designed for a cordless network. The keypad 2 has a first group 7 of keys as alphanumeric keys, by means of which the user can enter a telephone number, write a text message (SMS), write a name (associated with the phone number), etc. Each of the twelve alphanumeric keys 7 is provided with a figure "0-9" or a sign "#" or "\*", respectively. In alpha mode each key is associated with a number of letters and special signs used in text editing. The keypad 2 additionally comprises two soft keys 8, two call handling keys 9, and a navigation key 10.

The two soft keys 8 have a functionality corresponding to what is known from the phones Nokia 2110™, Nokia 8110™ and Nokia 3810™. The functionality of the soft key depends on the state of the phone and the navigation in the menu by using a navigation key. The present functionality of the soft keys 8 is shown in separate fields in the display 3 just above the keys 8.

The two call handling keys 9 are used for establishing a call or a conference call, terminating a call or rejecting an incoming call.

The navigation key 10 is an up/down key and is placed centrally on the front surface of the phone between the display 3 and the group of alphanumeric keys 7. Hereby the user will be able to control this key by simply pressing the up/down key using his/her thumb, i.e. it allows the user to scroll between a group of items in e.g. a menu provided in the user interface. Since many experienced phone users are used to one-hand control, it is a very good solution to place an input key, requiring precise motor movements. Thus, the user may place the phone in the hand between the finger tips and the palm of the hand. Hereby, the thumb is free for inputting information. In another embodiment, the scroll key can be a roller key (not shown), which is arranged to rotate in one or several directions. The roller allows the user to roll the key to scroll between different items in a menu. In case of a roller key, the soft key 8 could be arranged to the roller, i.e. upon pressing on the roller the same functionality, as the operation key has, could be entered. The roller key has a functionality corresponding to what is known from e.g. the phone Nokia 7110™, which also supports the Wireless Application Protocol (WAP). The roller key is incorporated by reference in US patent application 08/923,696.

Fig. 2 schematically shows the most essential parts of a preferred embodiment of the phone. These parts being essential to understand the invention. The preferred embodiment of the phone of the invention is adapted for use in connection with a GSM network, but, of course, the invention may also be applied in connection with other phone networks, such as other kinds of wireless networks and various forms of cordless phone systems or in dual band phones accessing sets of these systems/networks. The microphone 6 records the user's speech, and the analogue signals formed thereby are A/D converted in an A/D converter (not shown) before the speech is encoded in an audio part 14. The encoded speech signal is transferred to control means 18. The control means 18 comprises a processor, which may support

9

software in the phone. The control means 18 also forms the interface to the peripheral units of the apparatus, wherein the peripheral units can comprise a RAM memory 17a and a Flash ROM memory 17b, a SIM card 16, the display 3, a browser application 20, and the keypad 2 (as well as data, power supply, etc.). The browser application 20 can be used to request and receive content from a server, which is described in more detail hereinafter, with reference to Fig. 3-5. The control means 18 communicates with a transmitter/receiver means 19, e.g. a circuit which is adapted to send/receive a request/respond to/from a telecommunication network. The audio part 14 speech-decodes the signal, which is transferred from the control means 18 to the earpiece 5 via a D/A converter (not shown).

The control means 18 is connected to the user interface. Thus, it is the control means 18 which monitors the activity in the phone and controls the display 3 in response thereto. Therefore, it is the control means 18 which detects the occurrence of a state change event and changes the state of the phone and thus the display text. A state change event may be caused by the user when he activates the keypad including the navigation key 10, and these type of events are called entry events or user events. However, the network communicating with the phone may also cause a state change event. This type of event and other events beyond the user's control are called non user events. Non user events comprise status change during call set-up, change in battery voltage, change in antenna conditions, message on reception of SMS, etc.

25

Accessing location information from a server to a wireless communication terminal.

Figure 3 schematically shows a system 301, for accessing location information from a server. The system comprises a wireless communication

30

10

terminal 300, a wireless network 310, and a plurality of web servers 320, 330 and 340 in an Internet network 350. The Internet network 350 uses World Wide Web (WWW) protocols, and is provided with location means. The location means is arranged to receive/transmit data packets from/to the terminal. For example, the location means could be a database comprising digitised maps, and/or text information describing the location. The database can be updated continuously, in order to send updated location information to the terminal. The wireless network 310 is arranged to establish a wireless connection 305 between a plurality of wireless terminals 300 and linking means 360. Even if the linking means is usually connected to a server to be accessed, it is possible that the linking means may be integrated together with the server to be accessed, as well.

The terminals 300 are able to access at least one of the web servers 320-340 provided with location means, via the linking means 360. The terminals 300 could typically be a cellular phone. In general, the linking means 360 is arranged to enable a session for the wireless communication terminal 300 and to transmit data packets between the terminal and one of the web servers 320-340. Thus, the web servers 320-340 are arranged to receive and/or transmit data packets from/to the terminal 300. The transfer of data packets is often mentioned as pull and/or push. A pull could be described as the terminal using an access point to access a site where e.g. the location information is stored, and might also determine whether it has been updated and to retrieve it if necessary. In some cases it could also be possible to use a push, which could be described as the opposite to pull, i.e. the server maintains address data necessary to transfer updated location information to the terminal.

The linking means 360 in this example is typically a gateway or a proxy, but is hereafter referred to as gateway. A proxy server is a process that allows the user to fetch different types of documents, like WWW, FTP, and GOPHER

documents. The proxy server can store the documents in a cache memory in the radio terminal. What this means is that when anyone retrieves a document, besides transferring these files to the radio terminal, a copy can also be made on the local host. Thus, the next time the user accesses that document, a request is sent to the remote host to see if the page has been updated, and if not, it is read directly from the cache memory. A gateway can be a computer that lies at the intersection of a server to be accessed and a client, and routes traffic from one or several servers to the client. Thus, the function of the gateway is to provide a link between two disparate types of electronic communications such as WAP architecture and Internet architecture. Communication between a wireless terminal 300 and the gateway 360 is according to the Wireless Application Protocol (WAP).

WAP defines a set of standard protocols that enable communication between wireless communication terminals, like cellular phones and network servers. Other types of communication terminals could be pagers and personal digital assistants. WAP uses a standard naming model according to which standard Internet URLs are used to identify content on different web servers. It also uses content typing. All WAP content is given a specific type consistent with WWW typing which allows a wireless terminal to correctly process the content based on type. WAP also uses standard content formats and standard communication protocols. Thus, WAP brings Internet content and advanced data services to wireless terminals. WAP can work across differing wireless network technologies and bearer types (TDMA, CDMA, SMS). Communication between the web servers 320-340 and the gateway 360 is according to WWW protocols.

In this embodiment, the gateway 360 translates, i.e. formatting, requests for location information from a WAP protocol stack used by the wireless terminal 300 to a WWW (World Wide Web) protocol stack used by the web server. The

12

web server leaves a response with an indication of the location information, which can for example return WAP content such as WML (Wireless Markup Language), WMLScript, XML (Extensive Markup Language) and/or WWW content such as HTML (HyperText Markup Language). In the later case a filter  
5 is used to translate, i.e. format, the WWW content to WAP content e.g. HTML to WML, WMLScript or XML. In a preferred embodiment, the gateway is able to encode content sent over the wireless network to the wireless terminal and decode data sent to it by the wireless terminal. This means that the system, i.e. the terminal, the linking means and the server, can be provided with  
10 encoding/decoding means, which can enable a fast transmission of data packets between the server and the terminal. Hence, this enables a transfer of binary data packets, which is much easier (faster) to transfer than an uncoded data packet. One way of handling data packets in a binary format is to use so called WAP Binary Content Format, such as WBXML (Wireless Binary  
15 eXtended Markup Language).

In another preferred embodiment, the terminal can be provided with security means (not shown), which is able to demand a confirmation of the request sent to the server. The security means can be provided in the browser  
20 application, and can be either default or an optional feature, i.e. the user is able to or not able to interact. Hence, when the security means is activate, the user should confirm that he would like to send the request to the server. The major reason for having security means, is that the user in some cases reveals his position, which can be hazardous in some cases. For example, if  
25 you are not sure about the trustworthiness of the service provider. This means that when the request is processed at the server, a hacker could more easily find out that where the position of the user, or even worse include a virus in the response back to the terminal. Also, if the terminal is connected to position means, e.g. a navigation system for a vehicle, this could directly reveal the  
30 position of the user. Hence, the security means is able to provide the user



with some privacy, and not revealing any information to third parties without the user's permission.

Also, the system can also encrypt/decrypt data packets between the terminal  
5 and the server, in order to provide a high level of security when transmitting wireless information. The data packets comprising the request, the formatted request, the response and the formatted request. This means that the gateway can be provided with encoders and decoders (not shown). Also, the server may comprise different algorithms to make the encryption/decryption.  
10 The encryption/decryption itself may be performed by well-known methods, e.g. RSA, Diffie-Hellman, etc. Regardless of the way how the position is gathered in the WAP Client, i.e. the terminal, the user of a location dependent service must be able to decide to whom she/he gives her/his position information. Additionally the user wants to make sure that her/his position is  
15 only available to a specified origin server and not to other parties. The decision of the user to whom she/he wants to give the position information can be realised in many different ways. For example,

1. The user is prompted in every time a WMLScript function, is processed.
- 20 2. Managing a list of URLs, which point to trusted servers. The URL of the calling WMLScript could be checked against this list. This URL is known to the terminal by comparing the requested URL with a list of trusted servers. If the URL is reliable, the WMLScript function is executed. In the case of failure an invalid string can be returned.
- 25 3. The client, i.e. the terminal, could request to encrypt, every time the output of the script library with the mechanism defined in a crypto library. The crypto library provides a possibility to sign data of a client, and is able to encrypt user data before sending it.

14

4. A Server certificate can be used, which only identifies the linking means. If the WMLScript was requested from a origin server, which is not the linking means, the linking means has to take care of the privacy.
- 5 Applying the second option to this preferred embodiment means, that the client should check the URL of the calling WMLScript, before the script function is executed. Only if the WMLScript was requested or pushed from a trusted server, which is listed in a special position trusted server list, the script is processed. This list can be managed by the user. Also, the crypto library
- 10 could be a so called WMLScript Crypto Library which will offer the possibility to sign data of a client with a digital signature before transmitting these to the origin server. Additionally this library provides the possibility to encrypt the user data, before sending it.
- 15 A Wireless Application Environment which forms an upper layer of the WAP stack includes a browser application, also called a microbrowser. Typically, the encoding/decoding means is provided in the browser application of the terminal. The browser can use WML and a lightweight markup language, WMLScript a lightweight scripting language. WML implements a card and
- 20 deck metaphor. The interaction of the browser and user is described in a set of cards which are grouped together into a document commonly referred to as a deck. The user navigates to a card in a deck reviews its content and then navigates to another card in the same deck or in a different deck. The user is also able to enter requested information, makes choices, and move on to
- 25 another card. Decks of cards are transferred from origin servers as needed. Cards are grouped together into decks. Thus, the content which the user receives mostly from a server comprises cards and decks. A WML deck is similar to a HyperText Markup Language (HTML) page, in that it is identified by an URL, and is the unit of content transmission. WML includes text and
- 30 image support, including a variety of formatting and lay-out commands. WML

15

includes support of explicitly managing the navigation between cards and decks. WML also supports anchored links, similar to those in HTML.

The wireless communication terminal differs from a desktop or a portable  
5 computer with Internet facilities in that generally it has a less powerful CPU,  
less memory, restricted power consumption, smaller displays and more limited  
input devices. The wireless network differs from the Internet network in that it  
generally has less bandwidth, more latency, less connection stability and less  
predictable availability. The WAP architecture is optimised for narrow  
10 bandwidth bearers with potentially high latency and is optimised for efficient  
use of device resources.

Upon communicating with the wireless network 310, in order to receive,  
access and transmit data packets from e.g. the web server 320 through the  
15 gateway 360, the wireless communication terminal 300 comprises a receiver  
and a transmitter, see also Fig.2 ref. no. 19. The terminal 300 further  
comprises a memory, see Fig.2 ref. no. 16 (SIM card) and 17b (ROM),  
provided with an identifier and at least one item. The item is provided with an  
access point which indicates the location of the server to be accessed, which  
20 could be indicated by means of a URL (Uniform Resource Locator) address.  
In addition, the item can also comprise data packets from earlier sessions  
which is updated upon a new session to the same access point. The identifier  
is used to identify content at the address provided by the server, wherein the  
server is accessed by sending the identifier to the linking means to identify  
25 which type of content is requested at the server. In addition, the content is  
associated with link content, which is provided at different locations in the  
server 320 or in another server 330, 340.

Also, the item can comprise a script, which is arranged to provide provisions  
30 for accessing servers through linking means. The script can activate or

16

download linking applications from a gateway, i.e. an application which makes it possible to receive and/or transmit different types of data packets between the server and the terminal. For example, the different types of data packets can be a particular text format, software programs, picture formats. This can

5 be done by creating extensions to WML and WML script. Thus, the script can make it possible to access data packets, which might not be supported by the software in the terminal, by downloading the appropriate application, supporting the type of data format, directly to the terminal. In general, the data packets, can be data (content) stored or generated at an origin server 320.

10 The content of the data packet is typically displayed or interpreted by the client. This allows a standard WAP browser to be used and provides flexibility for new features, e.g. a service provider having location information supported by different formats dependent on the request. This can be done by creating extensions to WML-, WML script- and XML-documents. Thus, the script can

15 make it possible to access data packets, which might not be supported by the software in the terminal, by downloading the appropriate application, supporting the type of data format, directly to the terminal. In general, the data packets, is data (content) stored or generated at an origin server. The content of the data packet is to be displayed or interpreted by the client. For example,

20 one service provider supports a data packet comprising position information given by means of a satellite receiver, another server could support position information provided by cell identity information, and a third does not require any positioning information.

25 Instead of displaying the received content on a display provided on the phone, it is also possible to present the content by means of a speaker, which can be built in the phone or externally connected to the phone.

30 As mentioned before, the Wireless Application Environment forms an upper layer of the WAP stack, and includes a browser application. To access

17

different servers the terminal is provided with a browser application, like the so called microbrowser. The browser application is arranged to establish a session to at least a gateway by reading the item in the memory. Also, the browser application can also be provided with pull means to fetch the content comprising location information from the server 320, at the site indicated by the access point.

In accordance with the present invention, the terminal 300 comprising a user interface (as shown in Fig. 1 reference no. 2, 3, 4, 5, and 6), which is connected to the browser application. The user interface having a display for displaying content received from a server and user input means to control the browser, by providing an input to the browser application. The input means could for example be a keypad or voice recognition means) to provide an input to the browser application. An example of how the user interface can be displayed during a session is shown in Fig. 5a-b. The input means is shown in Fig. 1 as the keypad 2. The browser can be arranged in a ROM memory or on a SIM card, as shown in Fig. 2 ref. No. 17b and 16, respectively. Hence, the input can be made if the user presses a key on the keypad of the terminal, and activate a request to a server 320-340. This request is arranged to be sent through the transmitter as a data packet. The input comprising a query identifying location information, and is associated with at least one access point, indicating the site of the server 320 to be accessed. The terminal is able to send this request without sending any information about its position to the server, i.e. the request is independent of the position of the terminal 300. This means that the terminal 300 is able to send a request to the server for receiving an indication of location information, without revealing the position of the terminal upon sending the request to the server. The input is provided in the request, together with the access point, and arranged to receive content comprising an indication of the requested location information from the server. To receive content with location information, the server 320-340 is provided

18

with location means, which may comprise digitised maps and/or text information over different locations. In this embodiment, the location means can be a deck, comprising cards with requested location information, of a language supporting WAP, like WML, WMLscript, or XML. It is also possible to  
5 have it in another format, and format the indication of the location information into a suitable format at the linking means.

In a preferred embodiment, the terminal could be connected to position means 370, provided with connecting means 380 to be inputted to the  
10 terminal. The position means could be a global positioning system (GPS) receiver, or by using cell identity information. The connecting means 380 can comprise a wired link or a wireless link (like an infra-red link or a low power RF link (e.g. Bluetooth)). If it comprises a wired link, it can also comprise a cable provided with electrical plugs, to physically connect the position means  
15 to the terminal. If the connecting means is a wireless link, it is suitable to provide the terminal with an appropriate protocol, to control the position means. Naturally, the wired link should also be provided an appropriate protocol, to control the position means. The position means 370 could provide greater flexibility to the user. For example, one who would like to use a GPS  
20 receiver will be independent of the wireless network, or may choose a less expensive solution to provide position information. Another example of position means is one who would like to use the wireless communication network, could obtain position information by receiving cell identity information, by using time difference information, and/or using time of arrival  
25 information. Thus, it is possible to provide an input unit, in particular for the input of a target position. The result of this input can also be presented by an output unit in the positioning means, in particular for the output of path guiding data. To process the all data, the position means further comprising a computer, in particular for route planning. The computer could comprise a  
30 memory with a digitised road map and can be connected for data

transmission to the server via a communication unit. Hence, it is possible to present the content received from the server on the positioning means, e.g. by a display and/or a speaker connected to the positioning means.

5 Accordingly, as a response to the request, the server can send a position request, as an indication of the requested location information. This position request can be a WML-Script, which is then processed by the browsing application. The position response from the terminal can then either be a rejection of the position request, or it can send a position response back to  
10 the server indicating the position of the terminal. The position response can be provided by the positioning means, as mentioned above. After gathering the information to the position response, this information can be encoded to the binary representation of e.g. an XML-document. The output of this content encoding process, the binary representation of the XML-document, is then  
15 returned in the position response of the WMLScript request. This string is designed for the transmission to the linking means, which can be decoded at the linking means, and can be sent to the server as an XML document. Finally, the position response to the server is then able to fetch the content of the requested location information. This can be made by sending the  
20 requested location information through the linking means, back to the terminal. The presentation of the requested location information can be presented either directly to the user of the terminal, or it presented to the terminal itself. If the presentation is made on the terminal itself, it means that the terminal is able to update information itself. For example, if the user is  
25 driving and should focus on the driving, it is not always very convenient to request for updated information manually. Therefore, this feature automatically provides the user with updated location information without requiring any user interaction.

20

In a preferred embodiment of the present invention, where it is required by the server to have the actual position of the terminal, this embodiment provides different ways of obtaining position information, if the terminal is not able to provide position information itself. If the terminal is not able to obtain position

5 information, the terminal is able to send a content type or a header to the linking means, to provide the server with the requested position information. The header fields allow the terminal to pass additional information about the position request, and about the terminal itself, to the linking means. These fields act as request modifiers, with semantics equivalent to the parameters

10 on a programming language method (procedure) invocation. In this embodiment, it is preferred to use the content type. This content type or header might contain an indication that the terminal is not able to provide this position information, and it could be possible for the user of the terminal to set an option to search for alternative ways of obtaining the position information of

15 the terminal. This searching could e.g. be done by means of the linking means, or even by the server itself. If it is the linking means, which performs the search to find the location of the terminal, this information can be sent from the linking means to the server, e.g. as an XML-document, i.e. the linking means is able to generate an XML-document comprising the position

20 information. The position information can be obtained from the cell identity information, which is provided by the wireless telecommunication network, by using time difference information, and/or using time of arrival information. If it is the server, which performs the search to find the location of the terminal, this information will then be handled by server and generates the requested

25 location information, based on the obtained position information. The position information could also be obtained in the same manner as in the case of the linking means, i.e. by means of the cell identity information, which is provided by the wireless telecommunication network.



A method for providing location information from a server to a wireless communication terminal.

Fig. 4 shows a flow chart, in accordance with the present invention, describing  
5 a way of providing location information from a server through a wireless  
communication terminal. The wireless telecommunication terminal in this  
example is the same type as described in Fig.1 and 2, and the apparatus is  
hereafter also referred to as a phone. The phone is provided with a browser  
10 application and a memory which enables the user to browse among different  
objects on a server. This browsing can be done by using a browser  
application supporting WAP. When the phone is activated and establishes, a  
wireless connection to a wireless network, e.g. when the phone roams to a  
new network, "START" 500, it is possible to communicate with different  
15 telecommunication services, e.g. WAP related services, i.e. a service which  
can be accessed from a server to the phone. By using this kind of service, it  
might be possible to obtain information from a server to the phone, e.g. by  
using SMS (Short Message Service), or a similar service.

First, the user may select a browser menu on a display controlled by the  
20 browser application, which is connected to the memory. In this browser menu  
the user can choose to establish a session to a server comprising location  
means, e.g. in form of digitised maps and/or text giving indications of  
requested location information. In this embodiment, the location means can  
be a deck, comprising cards with requested location information, of a  
25 language supporting WAP, like WML, WMLscript, or XML. It is also possible to  
have it in another format, and format the indication of the location information  
into a suitable format at the linking means. To establish the session the user  
selects the service connected to the server from the menu. The selection is  
done by e.g. pressing on one of the softkeys as shown in Fig. 1.

30

22

In accordance with the present invention, the selection also comprise an input of location information inputted by means of e.g. the softkeys, which is independent of the position of the terminal. Then the browser application reads and identifies the content of an item from the memory, and the query  
5 identifying requested location information "READ ITEM" 510. This item comprises at least one access point, which indicates the location of the server to be accessed. The item might comprise more content than the access point, e.g. it is possible to have data packets received from an earlier session which is updated upon a new session to the same access point. The memory can  
10 also provided with an identifier, which is used to identify a content at the server. After reading the item from the memory, the browser application generates a request, "GENERATE REQUEST" 520, in order to receive an indication of the requested location information from the server, at the location indicated by the access point. This request comprising information of the  
15 access point to be accessed, the query of location information and the identifier identifying the content at the server. The information could for example be a URL address, where the server is located. The request is then sent through the transmitter as a data packet.

20 In a preferred embodiment, the terminal can be provided with security means (not shown), which is able to demand a confirmation of the request sent to the server. The security means can be provided in the browser application, and can be either default or an optional feature, i.e. the user is able to or not able to interact. Hence, the security means is able to provide the user with some  
25 privacy, and not revealing any information to third parties without the user's permission, i.e. when the security means is activate, the user should confirm that he would like to send the request to the server. This confirmation could for example occur if the server requires the actual position of the terminal. Then the response from the server could be a request for position information  
30 from the terminal, which the user can choose to accept and send the required

23

position information from the server. The major reason for having security means, is that the user in some cases reveals his position, which can be hazardous in some cases. For example, if you are not sure about the trustworthiness of the service provider. This means that when the request is  
5 processed at the server, a hacker could more easily find out that where the position of the user, or even worse include a virus in the response back to the terminal. Also, if the terminal is connected to the position means, as mentioned above, this could directly reveal the position of the user. To avoid this the WAP client, i.e. the terminal, should check the access point when  
10 calling a WMLScript, before the script function is executed. Only if the WMLScript was requested or pushed from a trusted server, which is listed in a special position trusted server list, the script is processed. This list can be managed by the user. Also, a crypto library could be a so called WMLScript Crypto Library which can offer the possibility to sign data of a client with a  
15 digital signature before transmitting these to the origin server. Additionally this library provides the possibility to encrypt the user data, before sending it.

In order to provide eventual position information to the server, the terminal could be connected to position means. The position means could be a global  
20 positioning system (GPS) receiver, or by using cell identity information. The position means could provide greater flexibility to the user. For example, one who would like to use a GPS receiver will be independent of the wireless network, or may choose a less expensive solutions to provide position information. Another example of position means is one who would like to use  
25 the wireless communication network, could obtain position information by receiving cell identity information, e.g. by using time difference information, and/or using time of arrival information.

The request is transmitted to linking means, "TRANSMIT REQUEST" 530, in  
30 order to establish a session between the linking means and the terminal. The

24

linking means is arranged to forward the data packets between the terminal and the server. The linking means could be a gateway or a proxy server, which links the requested information to the correct access point. If the linking means do not respond to the request, "RECEIVED REQUEST?" 540, e.g.

5 because the linking means is broken or the terminal does not have coverage to the wireless network, the terminal could receive an error message, which says that a connection to the linking means could not be established. Then, the user could choose to re-send the request once more, "TRANSMIT REQUEST" 530.

10

The item can comprise a script, which is arranged to provide provisions for accessing servers through the linking means. The script can activate or download linking applications from a gateway, i.e. an application which makes it possible to receive and/or transmit different types of data packets between

15 the server and the terminal. For example, the different types of data packets can be a particular text format, software programs, different picture formats, etc. This allows a standard WAP browser to be used and provides flexibility for new features, e.g. a service provider having location information supported by different formats dependent on the request. This can be done by creating

20 extensions to WML-, WML script- and XML-documents. Thus, the script can make it possible to access data packets, which might not be supported by the software in the terminal, by downloading the appropriate application, supporting the type of data format, directly to the terminal. In general, the data packets, is data (content) stored or generated at an origin server. The content

25 of the data packet is to be displayed or interpreted by the client. For example, one service provider supports a data packet comprising position information given by means of a satellite receiver, another server could support position information provided by cell identity information, and a third does not require any positioning information.

30

25

After the terminal has been connected to the linking means, the linking means can control that the access point is correct, "ACCESS POINT KNOWN?" 550. For example, if the user has requested access to a server which no longer exists, is misspelled, or for some other reason is no longer known, the linking  
5 means could transmit an error message. This error message could then be displayed on the terminal, "DISPLAY ERROR MESSAGE" 560, providing the user with information about the error. Then the session could be terminated, either by the user or the linking means, "END" 570. If the access point is known, the linking means can send a pull to the server, "SEND PULL TO THE  
10 SERVER" 580.

In a preferred embodiment, the gateway is able to encode content sent over the wireless network to the wireless terminal and decode data sent to it by the wireless terminal. This means that the system, i.e. the terminal, the linking  
15 means and the server, can be provided with encoding/decoding means, which can enable a fast transmission of data packets between the server and the terminal. Hence, this enables a transfer of binary data packets, which is much easier to transfer than an data packet which is not coded.

20 Also, the system can also encrypt/decrypt data packets between the terminal and the server, in order to provide a high level of security when transmitting wireless information. The data packets comprising the request, the formatted request, the response and the formatted request. This means that the gateway is provided with encoders and decoders (not shown). Also, the  
25 server comprises different algorithms to make the encryption/decryption. The encryption/decryption itself may be performed by well-known methods, e.g. RSA, Diffie-Hellman, etc. One way of handling data packets in a binary format is to use so called WAP Binary Content Format, such as WBXML (Wireless Binary eXtended Markup Language).

30

26

Finally, when the server has sent the requested information to the linking means, the requested location information will be linked (pushed) further from the linking means to the terminal, "DISPLAY CONTENT" 590. However, it is not necessary to display the received content, e.g. it could be directly stored  
5 in the memory. Finally, the session could be terminated, either by the user or the linking means, "END" 570.

A preferred embodiment will also be explained with reference to Fig. 6 in the following. Any optional features in Fig. 6 are marked with dashed lines/boxes.  
10 Box 600 represents a wireless communication terminal according to the invention, which could be a phone as mentioned before. This phone might be installed in a car and can be connected to a car navigation system.

The browser application 608 within the phone 600 generates a request, which  
15 comprises an access point, which indicates the site of the server 602, which can provide the requested location information. This access point is preferably a URL (Uniform Resource locator) as it is known from various internet applications.

20 The request for location information might be included in the URL itself or is attached to the request as a separate document. The request 610 is sent to the linking means 601, which is preferably a WAP gateway or a so called WAP proxy. The WAP proxy might receive the request from the phone 600 and forwards the request directly to the server 602 in step 611. Depending on  
25 the format of the request 610 from the phone the WAP proxy makes a protocol / format conversion in step 611 before it is forwarded to the server 602. The request is then forwarded to the server 602 in step 612.

The request 612 is then processed in box 614 at the server site. The result  
30 could be that some ready location information can be returned to the phone,

27

but in this example the result of the request processing is, that the position of the phone is necessary for the service.

Therefore the server 602 sends an indication of the requested location  
5 information in message 616 to the WAP proxy 601. The message 616 preferably contains a WML script which includes a script function to get the position of the phone 600. The message 616 is received by WAP Proxy 601 and if it is not already encoded, the WAP Proxy will encode the request in step 617. If it is encoded the WAP proxy 601 just forwards the message.

10

The encoded message is then transmitted to the phone 600 in step 618. The message 618 for obtaining the position information of the terminal 600 can be checked in step 620 for security/privacy reasons (i.e. the user is asked on the display if he agrees to return his position to the server). The user might allow  
15 to transmit the position or he gave in an earlier step a general agreement, that the position information can be given to this trusted server.

The received script function is then processed in step 622. During this process the position of the terminal is gathered from any available positioning  
20 system, which can indicate the position of the phone as described above. The result of the script processing 622 is a string which contains the representation of the position of the terminal in a format which can be recognised by the server 602.

25 This string is then optionally forwarded in step 626 to the encoding means 628. An example format after the encoding in step 628 could be a binary representation of a XML-document. Then it is forwarded through the transmitter of the phone 600 to the WAP proxy 601 in step 630. The string can also be forwarded directly (624,630) to the WAP proxy 601. An example  
30 of the return format in step 624 can be an XML-document.

The position message 632 contains the URL of the position requesting server besides the position information. If the string, which contains the position information, was already encoded in the phone 600 the WAP proxy decodes  
5 the string in step 634 before it is forwarded in step 636 to the server but the decoding can optionally also take place in step 638 at the server site 602.

However, if the terminal is not able to provide position information, and the server still needs to have the actual position of the terminal, there are  
10 alternative ways of obtaining this position information. Hence, if we look back on step 620 once more, and the terminal is no longer able to obtain position information, the terminal is able to forward this request of position information as a content type or a header to the linking means instead, i.e. step 632 is now a request instead of position information. The header fields allow the  
15 terminal to pass additional information about the position request, and about the terminal itself, to the linking means. These fields act as request modifiers, with semantics equivalent to the parameters on a programming language method (procedure) invocation. In this embodiment, it is preferred to use the content type. This content type or header might contain an indication that the  
20 terminal is not able to provide this position information, and it could be possible for the user of the terminal to set an option to search for alternative ways of obtaining the position information of the terminal. This searching could e.g. be done by means of the linking means, or even the server itself in some cases. If it is the linking means, which performs the search to find the  
25 location of the terminal, this information will be sent to the server, e.g. as an XML-document, i.e. the linking means is able to generate an XML-document comprising the position information. The position information can be obtained from the cell identity information, which is provided by the wireless telecommunication network, by using time difference information, and/or using  
30 time of arrival information. If it is the server, which performs the search to find



29

- the location of the terminal, this information can then be handled by server directly (or indirectly) and generates the requested location information, based on the obtained position information. If the position information is handled directly, the server is able to search for the position information without
- 5 sending a request to the terminal or the linking means. The position information can also be obtained in the same manner as in the case of the linking means, i.e. the cell identity information, which is provided by the wireless telecommunication network.
- 10 The server 602 can now process the complete request 610 in step 642 and returns the requested location information to the WAP proxy 601 in step 644. The response message 644 contains preferably a WML document. If the location information was not already encoded by the server it is encoded by the WAP proxy 601 in step 646 before it is forwarded to the phone 600 in step
- 15 648.

Each time when messages are transmitted between the WAP proxy 601 and the phone 600 a communication session needs to be established or already established sessions can be used for this purpose. Before the WAP proxy 601

20 transmits messages to the server 602 or the phone 600 it also checks if the message format is supported by the receiving terminal. If necessary the format is converted before the message is forwarded.

If the requested location information was originally eg a request for traffic

25 information from a car navigation system within a vehicle the received information is not necessarily presented to the user. It could be possible that the browser application just forwards the information to the car navigation system which re-calculates the route to a destination based on the received traffic information without notifying the user about details of the traffic

30 information. For example the user of a car navigation system also does not

30

need to be notified that the car navigation system initiated the request for traffic information before the car reached for example a motorway which is part of a calculated route to a destination.

5 The user interface.

With reference to Fig. 5a and 5b, an example is shown of how the display in a user interface can act when accessing a server according to the present invention. The user interface may comprise the same elements as shown in  
10 Fig.1, i.e. a keypad 2, a display 3, an on/off button 4, a speaker 5 and a microphone 6. Also, the terminal is provided with control means 18 as shown in Fig. 2, which controls the user interface. Starting from Fig. 5a, there is a layout 31 presented on a display in a phone, as shown in Fig.1 and 2, which indicates signal strength 35 from the wireless telecommunication network "D1  
15 Telekom" 40, the battery power 45 and a clock showing the time 50 in hours and minutes. Preferably, the display in the phone is an LCD (Liquid Crystal Display) display. The display, can be controlled by the control means. The layout 30 presents an example of the phone in idle mode, i.e. when the phone is activated and awaiting an action, e.g. an incoming or outgoing call. In the  
20 bottom of the display there are two items which are denoted as "Menu" 55 and "Names" 60. If the user selects "Names" 60 he/she can e.g. access a built in phone book. If the user selects "Menu" 55, he/she can select among several different menus. The actual selection of features in the bottom of the display, like "Menu" and "Names", can be selected by means of the soft keys  
25 disclosed with reference to Fig. 1.

One of the menus can be the next layout 65 called "Browser" 70. If the user chooses to use this menu, he/she can access different telecom related information services, e.g. Internet. One way of accessing this kind of  
30 information is to use the Wireless Application Protocol, WAP.

If the user chooses to select "Home" 71, this leads to the next layout 75, which graphically indicates, "Connecting to Service" 80. This shows an example of how the phone is trying to establish a connection to e.g. Internet, by sending an access request, through a gateway, to a server. If a connection is established to the gateway, some kind of welcome text for a home page might be displayed, "Welcome to D1 Web." 90. If the user selects "Options" 90, the terminal connects to the server which provides different services, which is graphically indicated by the same layout 75, indicating "Connecting to Service" 80. When the terminal is connected to the service, a list of selections can be displayed as shown in the following layout 110. For example, the different choices could be "Location information" 115, "White pages" 120, "Pizza" 125, "CNN" 130, etc. In this example the user selects to use the Location information 115, and browses further to the service in the next layout 135.

The numbers which refers to Fig. 5b are 135-210. In the layout 135 a browser display is shown with the selected item, which is indicated as a link to a service which provides a Location information. The user can select to chose this item, by using the "Options" 140.

For example, the layout can be provided with different editable fields and selection list placeholders, which in this example are shown in square brackets ([ ]). One selection in layout 160 can be highlighted (not shown), indicating a default state of the selection. In these fields, the user can input a location, e.g. a city or a street etc., "From:[Bochum]" 170, to another location, "To:[Düsseldorf]" 175. Hence, if the user presses "Options" 180, the user will be able to enter an editor to input the name of a location, e.g. "Düsseldorf"

32

185, like shown in layout 187. Thereafter, the user may press Ok 190, whenever he/she is done, or clear the location fields by selecting "Clear" 191.

If the user wishes to continue with his/her location related request, and  
5 chooses another city, the user selects the option "To [Graz]:" 225, which becomes highlighted upon selection, and is shown in layout 230. In the next layout 235, a selection list of available cities is displayed. The user selects e.g. "Gorden" 240 , and selects the entry by selecting "Ok" 245. The next layout 250 highlights the selected city to receive location information about.  
10 Thereafter, the user may select "Options" 260, which in this example activates the calculation of the location and the result "Gorden: Stau on route 66..." 265 is displayed with the selected information in the next layout 270. The arrow 280 indicates there is more information to read, which the user can see when he/she scroll down by e.g. the softkeys.

15

The invention is not limited to the above described and in the drawing shown an example of embodiments but can be varied within the scope of the appended claims. For example, it can be further possible to make the receiving of location information more flexible, by providing an option to the  
20 user to specify which server he/she would like to receive location information from.

**CLAIMS**

1. A method of providing location information from a server (320-340) to a  
5 wireless communication terminal (1,300) in response to a request sent (530)  
from the terminal (1,300), said terminal is provided with a browser application  
(20), and the server (320-340) is provided with location means, the method  
comprising the steps of:
- generating a request (520) by means of the browser application (20),  
10 the request comprising at least one access point indicating the site of  
the server (320-340) to be accessed, and a query identifying requested  
location information, said query being independent of the position of  
the terminal (1,300),
  - initiating a session to linking means (360), by sending the request (530)  
15 from the communication terminal (1,300) via a wireless  
telecommunication network (310) to the linking means (360),
  - identifying the request (350) at the linking means (360), by means of  
said access point,
  - formatting the request at the linking means into a format supported by  
20 the server, and sending the formatted request (580) to the server (320-  
340),
  - processing the query at the server (320-340) by means of said location  
means,
  - sending a response to said formatted request from the server (320-  
25 340) to the linking means (360), said response comprising an indication  
of the requested location information,
  - establishing a session between said terminal (1,300) and said linking  
means (360) by formatting the response into a format supported by the  
terminal (1,300), and sending the formatted response from the linking

34

means (360), via the wireless telecommunication network (310), to the terminal (1,300), and

- presenting (590) said indication of the requested location information on said terminal, by means of said browser application (20).

5

2. A method according to claim 1, characterised in that said terminal (1,300) is further provided with security means, wherein said security means demands a confirmation of the request being sent to the server (320-340).

10 3. A method according to claim 1 or 2, characterised in that said request, formatted request, response and/or formatted response are encrypted by the terminal (1,300), the linking means (360) and/or the server (320-340), in order to provide a high level of security when transmitting wireless information.

15 4. A method according to claim 1, 2 or 3, characterised in that said request, formatted request, response and/or formatted response are encoded by the terminal (1,300), the linking means (360) and/or the server (320-340), in order to provide a fast transmission of the request, formatted request, response and formatted response.

20

5. A method according to claim 1, 2, 3, or 4, characterised in that said location means is performing the processing, by means of a database comprising location information.

25 6. A method according to any of the preceding claims, characterised in that formulating the request, formatted request, response and/or formatted response by using WML (Wireless Markup Language), a WML-script, or a XML (eXtended Markup Language).

35

7. A method according to any of the preceding claims, characterised in that said linking means is optionally searching for position information of said terminal, which is requested by the server, and sending the requested position information from the linking means to the server.

5

8. A method according to claim 7, characterised in that the linking means is searching for position information by sending a cellular position request to the wireless telecommunication network, to obtain the position information requested by the server.

10

9. A method according to any of the claims 1-6, characterised in that said server is optionally searching for position information of said terminal, and sending the requested location information from the server based on the retrieved position information through the linking means to the terminal.

15

10. A method according to claim 9, characterised in that the server is searching for position information by sending a cellular position request to the wireless telecommunication network, to obtain the requested location information based on said position information.

20

11. A method according to any of the preceding claims, characterised in that said terminal is provided with position means, to determine position information of the terminal, and optionally sends the positioning information to the server, upon a request from the server, in order to give an indication of the position of the terminal.

25

12. A method according to any of the preceding claims, *characterised in* that said terminal (1,300) is provided with position means (370), to determine position information of the terminal, and optionally sends the positioning

36

information to the server (320-340) in the request sent to the server, in order to give an indication of the position of the terminal.

13. A method according to claim 11 or 12, *characterised in* that said  
5 positioning information is obtained by providing the position means (370) with cell identity information, using observed time difference information, and/or using time of arrival information, wherein this information being provided by means of the wireless communication network (310).
- 10 14. A method according to claim 11 or 12, *characterised in* that said positioning information is obtained by providing the position means (370) with a satellite positioning system, which provides positioning information independent of the wireless communication network (310).
- 15 15. A wireless communication terminal (1,300) for accessing location information from a server (320-340), the terminal (1,300) comprising
- a receiver and a transmitter (19) arranged to receive and transmit data packets from/to at least one server (320-340) comprising location means, through a wireless communication network (310) connected to linking  
20 means (360), said linking means (360) is arranged to forward the data packets between the terminal (1,300) and the server (320-340);
  - a memory (17a,17b) comprising at least one item, which is provided with an access point which indicates the site of the server (320-340) to be accessed, wherein the server is accessed by sending a request (530)  
25 through the wireless communication network (310) as a data packet comprising the access point to the linking means (360) to access and receive content from the server (320-340);
  - a browser application (20), arranged to establish a session to the linking means (360) by reading (510) the item from the memory (17a,17b) ,  
30 enable the transmitter (19) to send the request (530) as a data packet



37

through the linking means (360) to the server (320-340), and handle received content by means of said receiver (19), and

- a user interface (2-6) connected to the browser application (20), said user interface (2-6) having display means (3,13) for displaying content (590)

5 received from the server and user input means (2,6) to provide an input to the browser application,

characterised in that said input comprising a query of location information, which is independent of the position of the terminal (1,300), wherein the input is provided in the request, and arranged to receive and present content

10 comprising an indication of said location information from said server (320-340) by means of said location means.

16. A wireless communication terminal (1,300) according to claim 15, characterised in that said terminal is further comprising security means, 15 wherein said security means is arranged to demand a confirmation of the request being sent to the server (320-340).

17. A wireless communication terminal (1,300) according to claim 15 or 16, characterised in that said browsing application (20) is provided with 20 encryption/decryption means to send the request and receive the content in an encrypted format, in order to provide a high level of security when transmitting wireless information.

18. A wireless communication terminal (1,300) according to claim 15, 16 or 25 17, characterised in that said browsing application (20) is further provided with encoding/decoding means to send the request and receive the content in a coded format, in order to provide a fast transmission of data packets.

19. A wireless communication terminal (1,300) according to claim 15, 16, 30 17 or 18, characterised in that the browsing application (20) is arranged to

formulate the request, formatted request, response and/or formatted response by using WML (Wireless Markup Language), a WML-script, or a XML (eXtended Markup Language).

5 20. A wireless communication terminal (1,300) according to any of claims 15-19, *characterised in* that said terminal (1,300) is further comprising position means (370), arranged to determine position information of the terminal (1,300), and to optionally send the positioning information to the server (320-340), upon a request from the server, in order to give an indication of the  
10 position of the terminal (1,300).

21. A wireless communication terminal (1,300) according to any of claims 15-19, characterised in that said terminal (1,300) is further comprising position means (370), arranged to determine position information of the terminal  
15 (1,300), and to optionally send the positioning information to the server (320-340) in the request sent to the server, in order to give an indication of the position of the terminal (1,300).

22. A wireless communication terminal (1,300) according to claim 20 or 21,  
20 characterised in that said position means (370) is provided by means of the wireless communication network (310), which is arranged to receive cell identity information, using observed time difference information, and/or using time of arrival information.

25 23. A wireless communication terminal (1,300) according to claim 20 or 21, characterised in that said position means (370) is provided by means of a satellite positioning system, which is arranged to receive positioning information independent of the wireless communication network (310).

24. A wireless communication terminal (1,300) according to any of claims 15-23, characterised in that said terminal is a cellular phone.
25. A system (301) for accessing location information from a server (320-340), said system (301) comprising
- a wireless communication terminal (1,300) having:
    - a receiver and a transmitter (19) arranged to receive and transmit data packets from/to at least one server (320-340) comprising location means, through a wireless communication network (310) connected to linking means(360), said linking means (360) is arranged to forward the data packets between the terminal (1,300) and the server (320-340);
    - a memory (17a,17b) comprising at least one item, which is provided with an access point which indicates the site of the server (320-340) to be accessed, wherein the server is accessed by sending a request (530) through the wireless communication network (310) as a data packet comprising the access point to the linking means (360) to access and receive content from the server (320-340);
    - a browser application (20), arranged to establish a session to the linking means (360) by reading the item from the memory (17a,17b), enable the transmitter (19) to send the request as a data packet through the linking means (360) to the server (320-340), and handle received content by means of said receiver (19), and
    - input (2,6) means to provide an input to the browser application (20), in order to access location information from the server (320-340)
  - a wireless communication network (310), arranged to establish a connection between the wireless communication terminal (1,300) and linking means (360),
  - linking means (360), arranged to enable a session for said wireless communication terminal (1,300) and to forward data packets between the terminal (1,300) and a server (320-340), and

40

- at least one server (320-340) comprising location means, arranged to receive and/or transmit data packets from/to the terminal (1,300), characterised in that said input, provided by the input means (2,6) on the terminal (1,300), comprising a query of location information, which is  
5 independent of the position of the terminal, wherein the input is provided in the request, and arranged to receive and present content comprising an indication of said location information from said server (1,300) by means of said location means.
- 10 26. A system (301) according to claim 25, characterised in that said terminal (1,300) is further comprising security means, wherein said security means is arranged to demand a confirmation of the request being sent to the server (320-340).
- 15 27. A system (301) according to claim 25 or 26, characterised in that said system (301) is provided with encryption/decryption means arranged to said terminal (1,300), linking means(360), and/or server (320-340) to send the request and receive the content in an encrypted format, in order to provide a high level of security when transmitting wireless information.
- 20 28. A system (301) according to claim 25, 26 or 27, characterised in that said system (301) is further provided with encoding/decoding means arranged to said terminal(1,300), linking means (360), and/or server (320-340) to send the request and receive the content in a coded format, in order  
25 to provide a fast transmission of data packets.
29. A system (301) according to any of claims 25-28, characterised in that said terminal (1,300) is further comprising position means (370), arranged to determine position information of the terminal (1,300), and to optionally send

41

the positioning information to the server (320-340) upon a request from the server, in order to give an indication of the position of the terminal (1,300).

30. A system (301) according to any of claims 25-28, *characterised in* that  
5 said terminal (1,300) is further comprising position means (370), arranged to determine position information of the terminal (1,300), and to optionally send the positioning information to the server (320-340) in the request sent to the server, in order to give an indication of the position of the terminal (1,300).
- 10 31. A system (301) according to claim 29 or 30, characterised in that said position means (370) is provided by means of the wireless communication network (310), which is arranged to receive cell identity information, using observed time difference information, and/or using time of arrival information.
- 15 32. A system (301) according to claim 29 or 30, characterised in that said position means (370) is provided by means of a global satellite system, which is arranged to receive positioning information independent of the wireless communication network (310).
- 20 33. A system (301) according to any of claims 25-32, characterised in that communication between the server (320-340), the linking means (360) and the terminal (1,300) are in accordance with the Wireless Application Protocol.
- 25 34. A system (301) according to any of claims 25-33, characterised in that the terminal, linking means and/or server are arranged to formulate the request, formatted request, response and/or formatted response, respectively, by using WML (Wireless Markup Language), a WML-script, or a XML (eXtended Markup Language).

1 / 6

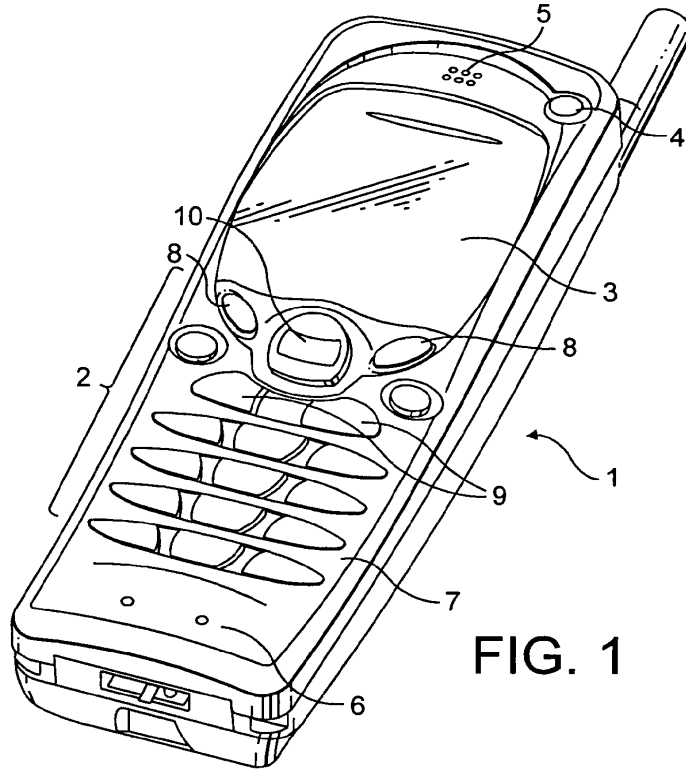


FIG. 1

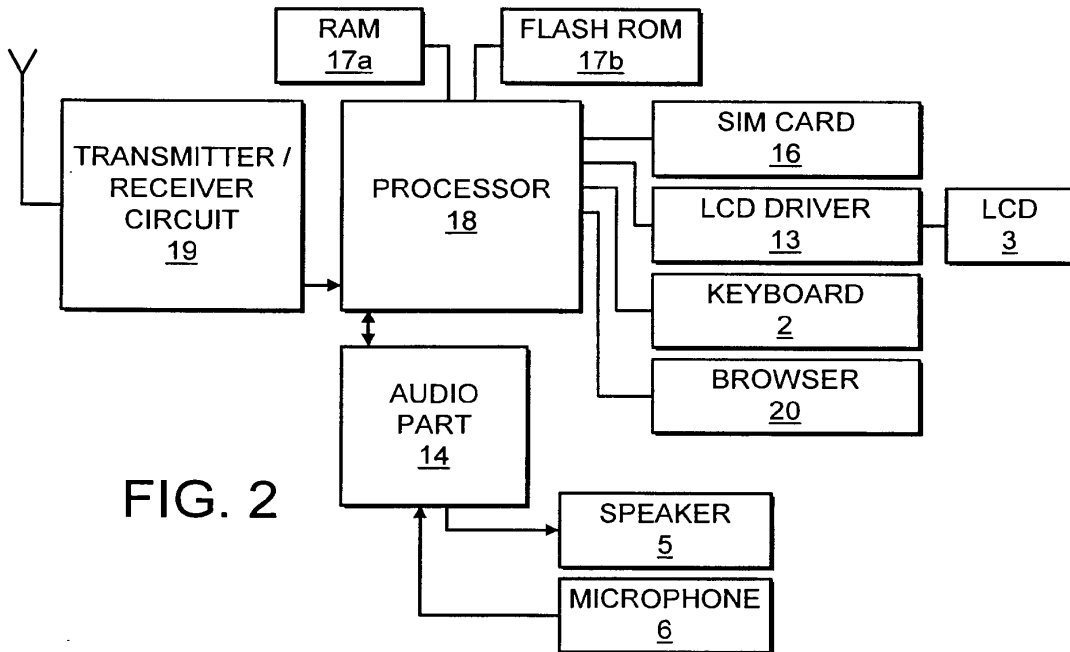


FIG. 2

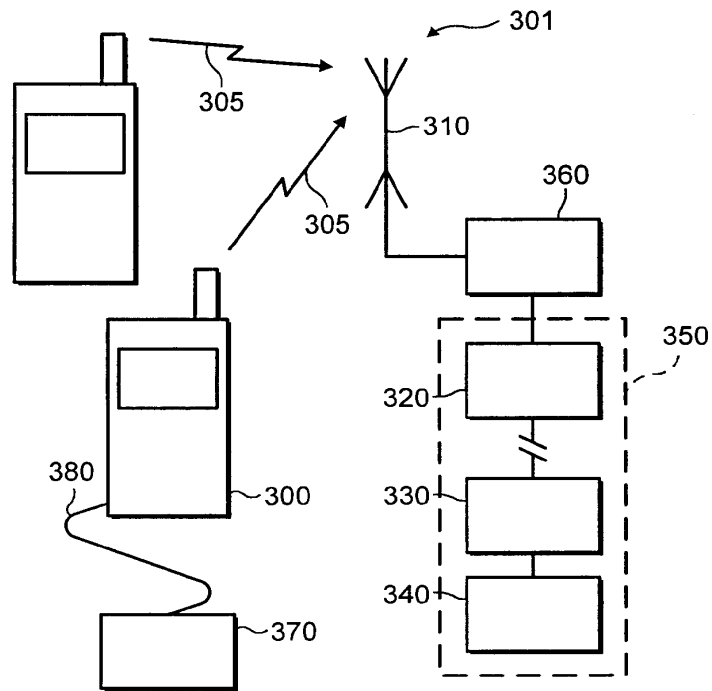


FIG. 3

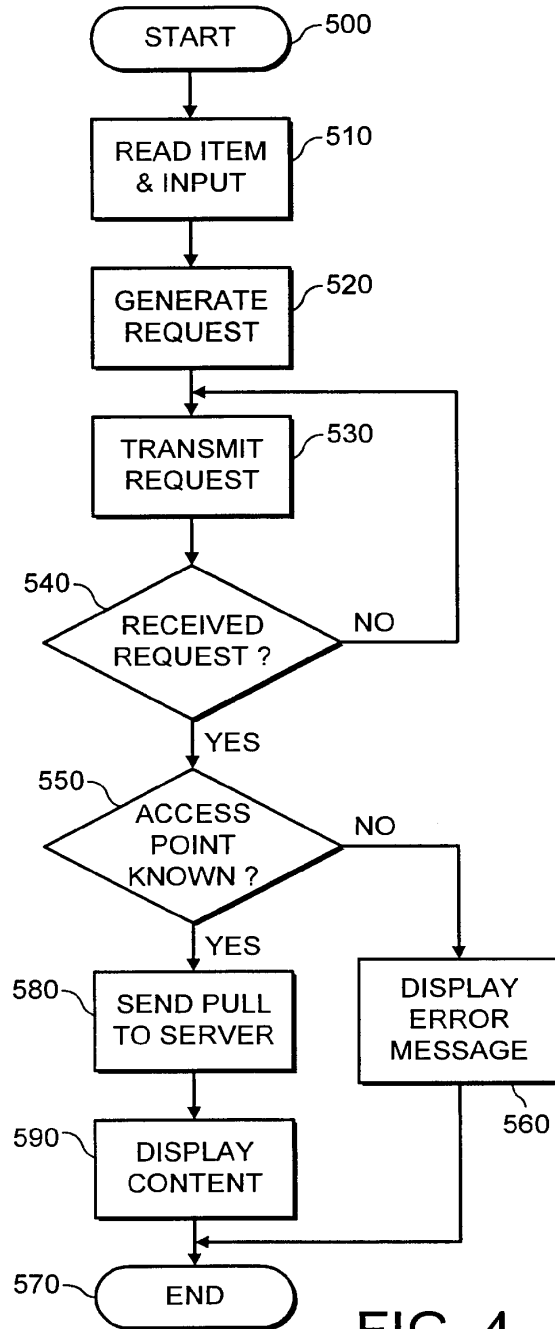
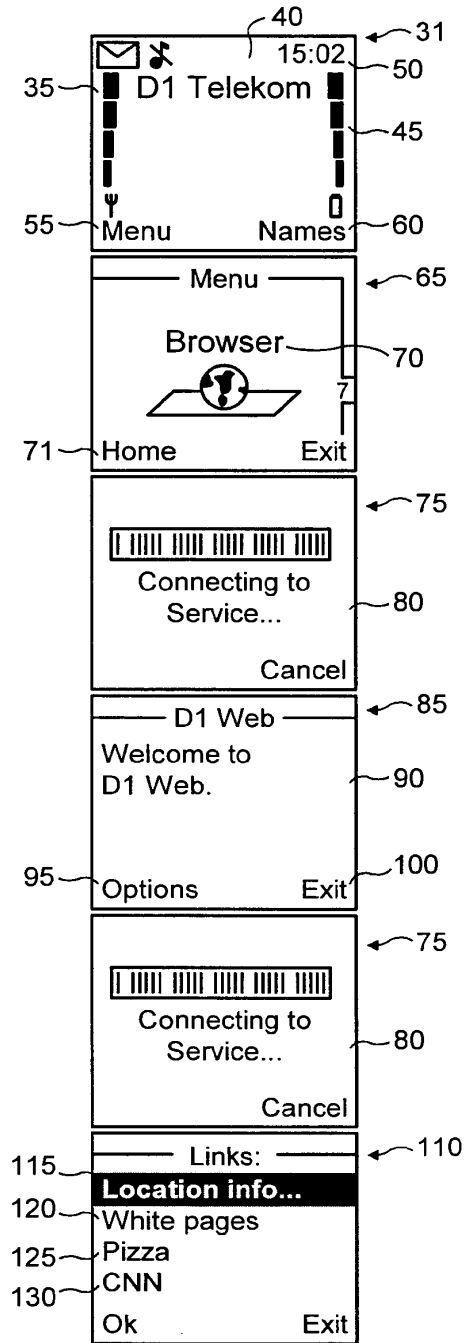


FIG. 4



FIG. 5a



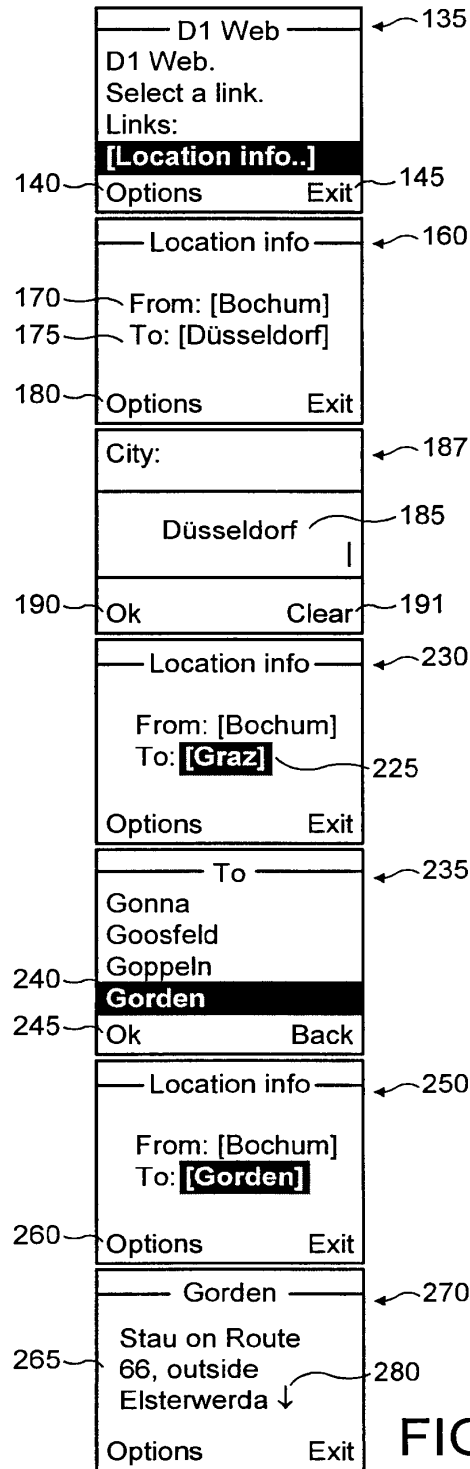


FIG. 5b

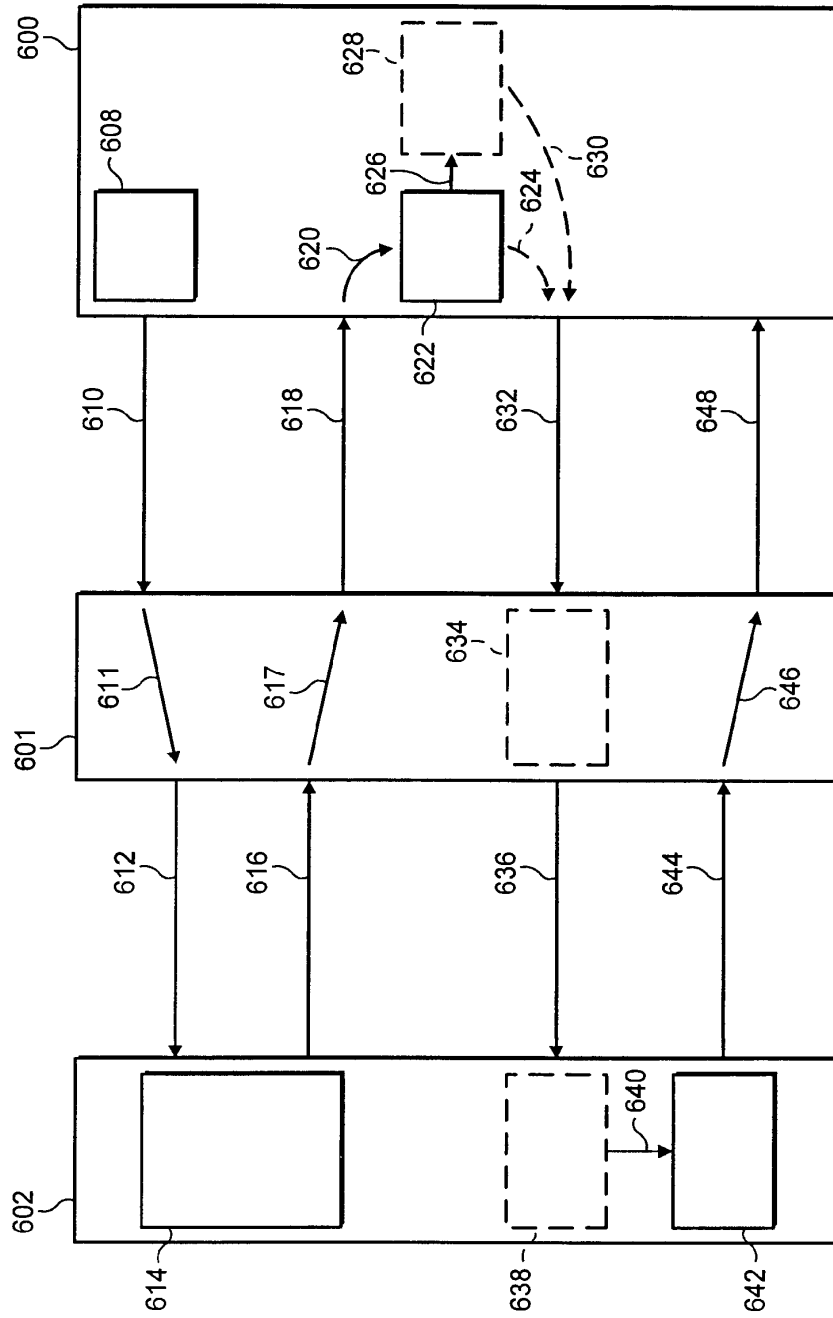


FIG. 6

# INTERNATIONAL SEARCH REPORT

|   |
|---|
| International Application No<br>PCT/EP 00/08521 |
|---|

|  |   |  |   |   |
|--|---|--|---|---|
| <b>A. CLASSIFICATION OF SUBJECT MATTER</b><br>IPC 7 H04Q7/22 H04L29/06   |   |  |   |   |
| According to International Patent Classification (IPC) or to both national classification and IPC  |   |  |   |   |
| <b>B. FIELDS SEARCHED</b>  |   |  |   |   |
| Minimum documentation searched (classification system followed by classification symbols)<br>IPC 7 H04Q H04L G05D G08G   |   |  |   |   |
| Documentation searched other than minimum documentation to the extent that such documents are included in the fields searched  |   |  |   |   |
| Electronic data base consulted during the international search (name of data base and, where practical, search terms used)<br>EPO-Internal, WPI Data, PAJ, INSPEC  |   |  |   |   |
| <b>C. DOCUMENTS CONSIDERED TO BE RELEVANT</b>  |   |  |   |   |
| Category *   | Citation of document, with indication, where appropriate, of the relevant passages  | Relevant to claim No.                              |   |   |
| X  | FUJINO N ET AL: "MOBILE INFORMATION SERVICE BASED ON MULTI-AGENT ARCHITECTURE" IEICE TRANSACTIONS ON COMMUNICATIONS, JP, INSTITUTE OF ELECTRONICS INFORMATION AND COMM. ENG. TOKYO, vol. E80-B, no. 10, 1 October 1997 (1997-10-01), pages 1401-1406, XP000734533 ISSN: 0916-8516<br>page 1, right-hand column, line 10 - line 17<br>page 2, left-hand column, line 16 -right-hand column, line 5<br>page 3, right-hand column, line 4 - line 11<br>page 4, left-hand column, line 19 -right-hand column, line 11<br>---<br>-/--  | 1-34   |   |   |
| <input checked="" type="checkbox"/> Further documents are listed in the continuation of box C. <span style="margin-left: 200px;"><input checked="" type="checkbox"/> Patent family members are listed in annex.</span>   |   |  |   |   |
| * Special categories of cited documents :  |   |  |   |   |
| <table style="width: 100%; border: none;"> <tr> <td style="width: 50%; border: none; vertical-align: top;">                     *A* document defining the general state of the art which is not considered to be of particular relevance<br/>                     *E* earlier document but published on or after the international filing date<br/>                     *L* document which may throw doubts on priority claim(s) or which is cited to establish the publication date of another citation or other special reason (as specified)<br/>                     *O* document referring to an oral disclosure, use, exhibition or other means<br/>                     *P* document published prior to the international filing date but later than the priority date claimed                 </td> <td style="width: 50%; border: none; vertical-align: top;">                     *T* later document published after the international filing date or priority date and not in conflict with the application but cited to understand the principle or theory underlying the invention<br/>                     *X* document of particular relevance; the claimed invention cannot be considered novel or cannot be considered to involve an inventive step when the document is taken alone<br/>                     *Y* document of particular relevance; the claimed invention cannot be considered to involve an inventive step when the document is combined with one or more other such documents, such combination being obvious to a person skilled in the art.<br/>                     *Z* document member of the same patent family                 </td> </tr> </table> |   |  | *A* document defining the general state of the art which is not considered to be of particular relevance<br>*E* earlier document but published on or after the international filing date<br>*L* document which may throw doubts on priority claim(s) or which is cited to establish the publication date of another citation or other special reason (as specified)<br>*O* document referring to an oral disclosure, use, exhibition or other means<br>*P* document published prior to the international filing date but later than the priority date claimed | *T* later document published after the international filing date or priority date and not in conflict with the application but cited to understand the principle or theory underlying the invention<br>*X* document of particular relevance; the claimed invention cannot be considered novel or cannot be considered to involve an inventive step when the document is taken alone<br>*Y* document of particular relevance; the claimed invention cannot be considered to involve an inventive step when the document is combined with one or more other such documents, such combination being obvious to a person skilled in the art.<br>*Z* document member of the same patent family |
| *A* document defining the general state of the art which is not considered to be of particular relevance<br>*E* earlier document but published on or after the international filing date<br>*L* document which may throw doubts on priority claim(s) or which is cited to establish the publication date of another citation or other special reason (as specified)<br>*O* document referring to an oral disclosure, use, exhibition or other means<br>*P* document published prior to the international filing date but later than the priority date claimed  | *T* later document published after the international filing date or priority date and not in conflict with the application but cited to understand the principle or theory underlying the invention<br>*X* document of particular relevance; the claimed invention cannot be considered novel or cannot be considered to involve an inventive step when the document is taken alone<br>*Y* document of particular relevance; the claimed invention cannot be considered to involve an inventive step when the document is combined with one or more other such documents, such combination being obvious to a person skilled in the art.<br>*Z* document member of the same patent family |  |   |   |
| Date of the actual completion of the international search  |   | Date of mailing of the international search report |   |   |
| 28 November 2000   |   | 04/12/2000   |   |   |
| Name and mailing address of the ISA<br>European Patent Office, P.B. 5818 Patentlaan 2<br>NL - 2280 HV Rijswijk<br>Tel. (+31-70) 340-2040, Tx. 31 651 epo nl,<br>Fax: (+31-70) 340-3016   |   | Authorized officer<br><br>Heinrich, D              |   |   |

INTERNATIONAL SEARCH REPORT

International Application No  
PCT/EP 00/08521

| C.(Continuation) DOCUMENTS CONSIDERED TO BE RELEVANT |  |                       |
|--|--|-----------------------|
| Category °   | Citation of document, with indication, where appropriate, of the relevant passages   | Relevant to claim No. |
| A  | <p>WO 99 27742 A (ERICSSON GE MOBILE INC)<br/>3 June 1999 (1999-06-03)<br/>cited in the application<br/>page 6, line 10 - line 28<br/>page 7, line 3 - line 18<br/>page 8, line 5 - line 17<br/>-----</p>  | 1-34                  |
| A  | <p>WO 98 59506 A (TELIA AB)<br/>30 December 1998 (1998-12-30)<br/>page 2, line 19 -page 3, line 1<br/>page 3, line 23 -page 4, line 9<br/>page 5, line 1 - line 12<br/>page 6, line 20 -page 7, line 6<br/>page 7, line 26 -page 8, line 4<br/>page 8, line 16 - line 18<br/>-----</p> | 1-34                  |
| A  | <p>US 5 673 322 A (BROCKMAN JAMES JOSEPH ET AL)<br/>30 September 1997 (1997-09-30)<br/>column 6, line 53 - line 67<br/>column 7, line 15 - line 37<br/>column 7, line 58 - line 65<br/>column 8, line 6 - line 16<br/>-----</p>  | 1-34                  |

# INTERNATIONAL SEARCH REPORT

Information on patent family members

|   |
|---|
| Intern. Application No<br>PCT/EP 00/08521 |
|---|

| Patent document cited in search report |   | Publication date | Patent family member(s)  | Publication date   |
|--|---|------------------|--|--|
| WO 9927742                             | A | 03-06-1999       | US 6088594 A<br>AU 1596399 A<br>BR 9815041 A   | 11-07-2000<br>15-06-1999<br>03-10-2000   |
|  |   |                  |  |  |
| WO 9859506                             | A | 30-12-1998       | SE 9702388 A   | 24-12-1998   |
|  |   |                  |  |  |
| US 5673322                             | A | 30-09-1997       | AU 707755 B<br>AU 5525696 A<br>CA 2247536 A<br>CN 1215518 A<br>EP 0885501 A<br>JP 11507152 T<br>WO 9735402 A | 22-07-1999<br>10-10-1997<br>25-09-1997<br>28-04-1999<br>23-12-1998<br>22-06-1999<br>25-09-1997 |
|  |   |                  |  |  |

IN THE UNITED STATES PATENT AND TRADEMARK OFFICE

|  |                             |
|--|-----------------------------|
| Applicant(s): Reed   |                             |
| Serial No.: 16/788,498   | Group Art Unit: --Unknown-- |
| Filed: 2/12/2020   | Examiner: --Unknown--       |
| Title: MOBILE WIRELESS DEVICE<br>PROVIDING OFF-LINE AND ON-<br>LINE GEOGRAPHIC NAVIGATION<br>INFORMATION |                             |
| Attorney Docket No.: TX1000-C12  |                             |

Commissioner for Patents  
P.O. Box 1450  
Alexandria, VA 22313-1450

**INFORMATION DISCLOSURE STATEMENT**

Dear Sir:

This Information Disclosure Statement is submitted:

- under 37 CFR 1.97(b), or  
(Within three months of filing national application; or date of entry of international application; or before mailing date of first office action on the merits; whichever occurs last)
- under 37 CFR 1.97(c) together with either a:  
 Statement under 37 CFR 1.97(e), or  
 a \$240.00 fee under 37 CFR 1.17(p), or  
(After the CFR 1.97(b) time period, but before final action or notice of allowance, whichever occurs first)
- under 37 CFR 1.97(d) together with a:  
 Statement under 37 CFR 1.97(e), and  
 a \$240.00 fee set forth in 37 CFR 1.17(p).  
(Filed after final action or notice of allowance, whichever occurs first, but before payment of the issue fee)
- Applicant(s) submit herewith Form PTO 1449-Information Disclosure Citation together with copies, of patents, publications or other information of which applicant(s) are aware, for which there may be a duty to disclose in accordance with 37 CFR 1.56.

While this Information Disclosure Statement may be "material" pursuant to 37 C.F.R. 1.56, it is not intended to constitute an admission that any patent, publication or other information referred to herein is "prior art" for this invention unless specifically designated as such.

In accordance with 37 C.F.R. 1.97(g) the filing of this Information Disclosure Statement shall not be construed to mean that a search has been made or that no other material information as defined in 37 CFR 1.56 (b) exists.

Any fee required above for the submission of this IDS has been paid via EFS-WEB. However, in the event that another fee is required in connection with the enclosed Information Disclosure Statement, the Commissioner of Patents and Trademarks is authorized to charge Deposit Account No. 50-3808 for the necessary amount.

Respectfully submitted,

/Andrew Mitchell Harris #42,638/

Andrew Mitchell Harris  
Attorney/Agent for Applicant(s)  
Reg. No. 42638  
Date: February 20, 2020  
Telephone No.: 866-553-4918



## Electronic Acknowledgement Receipt

|   |   |
|---|---|
| <b>EFS ID:</b>                              | 38655845  |
| <b>Application Number:</b>                  | 16788498  |
| <b>International Application Number:</b>    |   |
| <b>Confirmation Number:</b>                 | 8054  |
| <b>Title of Invention:</b>                  | MOBILE WIRELESS DEVICE PROVIDING OFF-LINE AND ON-LINE GEOGRAPHIC NAVIGATION INFORMATION |
| <b>First Named Inventor/Applicant Name:</b> | Mark Jefferson Reed   |
| <b>Customer Number:</b>                     | 59911   |
| <b>Filer:</b>                               | Andrew Mitchell Harris/Leigh Jones  |
| <b>Filer Authorized By:</b>                 | Andrew Mitchell Harris  |
| <b>Attorney Docket Number:</b>              | TX1000-C12  |
| <b>Receipt Date:</b>                        | 21-FEB-2020   |
| <b>Filing Date:</b>                         |   |
| <b>Time Stamp:</b>                          | 14:06:51  |
| <b>Application Type:</b>                    | Utility under 35 USC 111(a)   |

### Payment information:

|                        |    |
|------------------------|----|
| Submitted with Payment | no |
|------------------------|----|

### File Listing:

| Document Number | Document Description  | File Name                          | File Size(Bytes)/<br>Message Digest                     | Multi Part /.zip | Pages (if appl.) |
|-----------------|-----------------------|------------------------------------|---|------------------|------------------|
| 1               | Non Patent Literature | VUCETIC_SignalMontoringSystem_.pdf | 1117531<br><br>2e339d1da910d21e7f805b3b2172df96c0225ee2 | no               | 5                |

### Warnings:

|                     |                       |   |  |    |     |
|---------------------|-----------------------|---|--|----|-----|
| <b>Information:</b> |                       |   |  |    |     |
| 2                   | Non Patent Literature | 3GPP_TS25_331_V3_.pdf   | 26001861                                 | no | 708 |
|                     |                       |   | 526b6faa1fadafdc9346bc0e9e2fa8e5dd07b28b |    |     |
| <b>Warnings:</b>    |                       |   |  |    |     |
| <b>Information:</b> |                       |   |  |    |     |
| 3                   | Non Patent Literature | 3GPP_3GTS23_271_.pdf  | 863616                                   | no | 57  |
|                     |                       |   | 744ba86f892843cfeefd26dec249832f54b7055a |    |     |
| <b>Warnings:</b>    |                       |   |  |    |     |
| <b>Information:</b> |                       |   |  |    |     |
| 4                   | Non Patent Literature | Bennington_WirelessAndrew_Experience_.pdf                     | 2370763                                  | no | 11  |
|                     |                       |   | 29b8e62472342e659f3b9168fed3c18a3e190673 |    |     |
| <b>Warnings:</b>    |                       |   |  |    |     |
| <b>Information:</b> |                       |   |  |    |     |
| 5                   | Non Patent Literature | Anhalt_TowardContextAwareComputing_.pdf                       | 5858507                                  | no | 9   |
|                     |                       |   | 8985e003d8b752b9b5386878a781b98db35dfd2c |    |     |
| <b>Warnings:</b>    |                       |   |  |    |     |
| <b>Information:</b> |                       |   |  |    |     |
| 6                   | Non Patent Literature | Eckhardt_MeasurementAndAnalysisOfTheErrorCharacteristics_.pdf | 697285                                   | no | 12  |
|                     |                       |   | e890352fb3e870624ffcca109d705d40af2e1320 |    |     |
| <b>Warnings:</b>    |                       |   |  |    |     |
| <b>Information:</b> |                       |   |  |    |     |
| 7                   | Non Patent Literature | HE_Waveguard_.pdf   | 2895859                                  | no | 9   |
|                     |                       |   | 65935c50f2d685259d387f2453a812a14af9b03  |    |     |
| <b>Warnings:</b>    |                       |   |  |    |     |
| <b>Information:</b> |                       |   |  |    |     |
| 8                   | Non Patent Literature | Hills_LargeScaleWirelessLandscape_sign_.pdf                   | 474383                                   | no | 7   |
|                     |                       |   | efca6f215339e0d9d4e6160700c58f88d3a490   |    |     |
| <b>Warnings:</b>    |                       |   |  |    |     |
| <b>Information:</b> |                       |   |  |    |     |

|                     |                       |  |   |    |   |
|---------------------|-----------------------|--|---|----|---|
| 9                   | Non Patent Literature | Hills_BringingMobileComputingToAUniversity_.pdf                                    | 1337687<br>b6a66bd91d06a5af4a33e5d796596331c88085e4 | no | 5 |
| <b>Warnings:</b>    |                       |  |   |    |   |
| <b>Information:</b> |                       |  |   |    |   |
| 10                  | Non Patent Literature | Hills_SeamlessAccess_AWirelessDataNetworkInfrastructure_.pdf                       | 2424899<br>044185c5ce7d5538bfb44e1463f42aee7b62bc97 | no | 8 |
| <b>Warnings:</b>    |                       |  |   |    |   |
| <b>Information:</b> |                       |  |   |    |   |
| 11                  | Non Patent Literature | Johnson_TrulySeamlessWireless_ProtocolsForAdaptiveWirelessAndMobileNetworking_.pdf | 2842521<br>b3efaa61940df3c3f01a7b4cf11a68d484fe155  | no | 9 |
| <b>Warnings:</b>    |                       |  |   |    |   |
| <b>Information:</b> |                       |  |   |    |   |
| 12                  | Non Patent Literature | Small_DeterminingUserLocation_.pdf   | 622485<br>d4c3b82e13b9be47bb535130e7db9fc28c3d8f64  | no | 8 |
| <b>Warnings:</b>    |                       |  |   |    |   |
| <b>Information:</b> |                       |  |   |    |   |
| 13                  | Non Patent Literature | Hassan_CellularOptimization_.pdf   | 2606034<br>c9e874ae82668a15a7e8a3d708b8514da17d7e6e | no | 3 |
| <b>Warnings:</b>    |                       |  |   |    |   |
| <b>Information:</b> |                       |  |   |    |   |
| 14                  | Non Patent Literature | Miletic_LookingForTrouble_.pdf   | 1917819<br>5e10ebf9d6750e3c095a3067e368111fd7bd47e4 | no | 2 |
| <b>Warnings:</b>    |                       |  |   |    |   |
| <b>Information:</b> |                       |  |   |    |   |
| 15                  | Non Patent Literature | Bisdikian_EnablingLocationBasedApp_.pdf  | 754660<br>922388de13733cd4648fd591de2590f3051b3a0d  | no | 5 |
| <b>Warnings:</b>    |                       |  |   |    |   |
| <b>Information:</b> |                       |  |   |    |   |

|                     |                       |   |  |    |    |
|---------------------|-----------------------|---|--|----|----|
| 16                  | Non Patent Literature | Ateniese_UntraceableMobility.pdf                  | 2484785<br>da39bb84e0c958fc647e4c2e5aa8c3cc0605ed9f  | no | 14 |
| <b>Warnings:</b>    |                       |   |  |    |    |
| <b>Information:</b> |                       |   |  |    |    |
| 17                  | Non Patent Literature | Lee_EnhancedPrivacyAndAuthentication_.pdf         | 686315<br>8661bfec676594ebf41226242e77037499d857cf   | no | 13 |
| <b>Warnings:</b>    |                       |   |  |    |    |
| <b>Information:</b> |                       |   |  |    |    |
| 18                  | Non Patent Literature | Bera_PerformanceAnalysis_.pdf                     | 1474426<br>af331c9b28e1a361b347fefa8527c7067d733fa   | no | 8  |
| <b>Warnings:</b>    |                       |   |  |    |    |
| <b>Information:</b> |                       |   |  |    |    |
| 19                  | Non Patent Literature | Hepsaydir_MobilePositioningInCDMA_.pdf            | 624916<br>75d61cfd3b64677695b80a6f9095dbd3ec11ebe    | no | 5  |
| <b>Warnings:</b>    |                       |   |  |    |    |
| <b>Information:</b> |                       |   |  |    |    |
| 20                  | Non Patent Literature | Xie_DynamicLocationArea_.pdf                      | 1341081<br>7464eb1e55517a24bfa3478581dbe1b1a935f804  | no | 4  |
| <b>Warnings:</b>    |                       |   |  |    |    |
| <b>Information:</b> |                       |   |  |    |    |
| 21                  | Non Patent Literature | Leonhardt_TowardsAGeneralLocationService.pdf      | 4362697<br>c88b2cde775798fb4d30005b5bdf2c028c72ef653 | no | 8  |
| <b>Warnings:</b>    |                       |   |  |    |    |
| <b>Information:</b> |                       |   |  |    |    |
| 22                  | Non Patent Literature | GSM_DigitalCellularTelecommunicationsSystems_.pdf | 1207981<br>79b550d9d84a957d796c2731ee7e19762bda9ed1  | no | 11 |
| <b>Warnings:</b>    |                       |   |  |    |    |
| <b>Information:</b> |                       |   |  |    |    |

|                     |                       |                                |   |    |     |
|---------------------|-----------------------|--------------------------------|---|----|-----|
| 23                  | Non Patent Literature | 3GPP_3GTS21_101_V3_.pdf        | 931254                                    | no | 14  |
|                     |                       |                                | 02b4cc456f5e62cc8292f2da31d62ecc085a81fe  |    |     |
| <b>Warnings:</b>    |                       |                                |   |    |     |
| <b>Information:</b> |                       |                                |   |    |     |
| 24                  | Non Patent Literature | 3GPP_TS22_071_v4_.pdf          | 4172271                                   | no | 40  |
|                     |                       |                                | 057b68b4546c4a35c7e45fea7117175dfa8b9cc32 |    |     |
| <b>Warnings:</b>    |                       |                                |   |    |     |
| <b>Information:</b> |                       |                                |   |    |     |
| 25                  | Non Patent Literature | 3GPP_TS25_141_v3_.pdf          | 4185286                                   | no | 103 |
|                     |                       |                                | 07aaa8cd40e66ebbdcf264b1068ca3c3c86fd1f5  |    |     |
| <b>Warnings:</b>    |                       |                                |   |    |     |
| <b>Information:</b> |                       |                                |   |    |     |
| 26                  | Non Patent Literature | 3GPP_TS25_214_v3_.pdf          | 721330                                    | no | 6   |
|                     |                       |                                | a9ba45f1ef48b66ac67bd0d51080a762eea4a881  |    |     |
| <b>Warnings:</b>    |                       |                                |   |    |     |
| <b>Information:</b> |                       |                                |   |    |     |
| 27                  | Non Patent Literature | 3GPP_TS25_304_v3_.pdf          | 3570595                                   | no | 41  |
|                     |                       |                                | 9acc8b65460782c6a2508a746f141e109fd357    |    |     |
| <b>Warnings:</b>    |                       |                                |   |    |     |
| <b>Information:</b> |                       |                                |   |    |     |
| 28                  | Non Patent Literature | Acharya_MobilityMgmt_.pdf      | 4547318                                   | no | 10  |
|                     |                       |                                | 18821812180031d438048693b2eb4fd9a0227235  |    |     |
| <b>Warnings:</b>    |                       |                                |   |    |     |
| <b>Information:</b> |                       |                                |   |    |     |
| 29                  | Non Patent Literature | Akyol_ReroutingForHandoff_.pdf | 3238499                                   | no | 8   |
|                     |                       |                                | dafa7e3b3c7fc032d2799174c1a98196bb07e136  |    |     |
| <b>Warnings:</b>    |                       |                                |   |    |     |
| <b>Information:</b> |                       |                                |   |    |     |

|                     |                       |  |  |    |    |
|---------------------|-----------------------|--|--|----|----|
| 30                  | Non Patent Literature | Akyol_HandlingMobility_.pdf                  | 1699861                                  | no | 9  |
|                     |                       |  | 3a952bc7c753cb1ee47184aded9249094b7a461c |    |    |
| <b>Warnings:</b>    |                       |  |  |    |    |
| <b>Information:</b> |                       |  |  |    |    |
| 31                  | Non Patent Literature | LIU_MobilityModeling_.pdf                    | 2806368                                  | no | 15 |
|                     |                       |  | f8e1f3278b07542d38360ce14c032d614d131d1c |    |    |
| <b>Warnings:</b>    |                       |  |  |    |    |
| <b>Information:</b> |                       |  |  |    |    |
| 32                  | Non Patent Literature | Balakrishnan_ImprovingReliableTransport_.pdf | 2680977                                  | no | 13 |
|                     |                       |  | e70d51a2944d89d068cbe7c98211c1ca8a965e91 |    |    |
| <b>Warnings:</b>    |                       |  |  |    |    |
| <b>Information:</b> |                       |  |  |    |    |
| 33                  | Non Patent Literature | Ahonen_CellularNetworkOptimisation_.pdf      | 6886775                                  | no | 51 |
|                     |                       |  | 9a764641ef1c6d8a0bfecf429404e74fa18357b8 |    |    |
| <b>Warnings:</b>    |                       |  |  |    |    |
| <b>Information:</b> |                       |  |  |    |    |
| 34                  | Non Patent Literature | Raychaudhuri_WATMnet_.pdf                    | 3041910                                  | no | 13 |
|                     |                       |  | 2e1f02e6b334f02e8e7f1e67d7c067b69876d3e7 |    |    |
| <b>Warnings:</b>    |                       |  |  |    |    |
| <b>Information:</b> |                       |  |  |    |    |
| 35                  | Non Patent Literature | Small_LocationDetermination_.pdf             | 4220208                                  | no | 37 |
|                     |                       |  | 7ce72e808c3c6041acb12745e7dd5288103a7f0f |    |    |
| <b>Warnings:</b>    |                       |  |  |    |    |
| <b>Information:</b> |                       |  |  |    |    |
| 36                  | Non Patent Literature | Steele_MobileRadioCommunications_.pdf        | 2415746                                  | no | 20 |
|                     |                       |  | 5a8bfc102d8dd0d7cf8407000c7e40e6d0f65066 |    |    |
| <b>Warnings:</b>    |                       |  |  |    |    |
| <b>Information:</b> |                       |  |  |    |    |

|                     |                       |  |   |    |    |
|---------------------|-----------------------|--|---|----|----|
| 37                  | Non Patent Literature | ITU_BasicParameters_.pdf                     | 916977                                    | no | 8  |
|                     |                       |  | 3acc435c345f779ddb34d012c885e2c3dd7bde90  |    |    |
| <b>Warnings:</b>    |                       |  |   |    |    |
| <b>Information:</b> |                       |  |   |    |    |
| 38                  | Non Patent Literature | Varshney_MobileCommerce_.pdf                 | 1174481                                   | no | 7  |
|                     |                       |  | f6f4dc6e58102cefdfc9653f4aa0a665cba83fa8b |    |    |
| <b>Warnings:</b>    |                       |  |   |    |    |
| <b>Information:</b> |                       |  |   |    |    |
| 39                  | Non Patent Literature | Veeraraghavan_MobilityAndConnectionMgmt_.pdf | 2254756                                   | no | 19 |
|                     |                       |  | f1ab404baece745df3158c6f4ccb909688c5b935  |    |    |
| <b>Warnings:</b>    |                       |  |   |    |    |
| <b>Information:</b> |                       |  |   |    |    |
| 40                  | Non Patent Literature | Yamamoto_PositionLocationTech_.pdf           | 621638                                    | no | 5  |
|                     |                       |  | 6ccd938deb95166c477c899043bfb2b7ceeb527   |    |    |
| <b>Warnings:</b>    |                       |  |   |    |    |
| <b>Information:</b> |                       |  |   |    |    |
| 41                  | Non Patent Literature | Yu_AdaptiveResourceAllocation_.pdf           | 2911624                                   | no | 18 |
|                     |                       |  | 5fef0402cb5f05d6b59435e11a6954842b1203d8  |    |    |
| <b>Warnings:</b>    |                       |  |   |    |    |
| <b>Information:</b> |                       |  |   |    |    |
| 42                  | Non Patent Literature | Yuan_ASignalingAndControlArchitecture_.pdf   | 1432666                                   | no | 12 |
|                     |                       |  | 979280635ee9c85bd5712fba9e195f1bbd0fe219  |    |    |
| <b>Warnings:</b>    |                       |  |   |    |    |
| <b>Information:</b> |                       |  |   |    |    |
| 43                  | Non Patent Literature | Chiasson_FieldMeasurements_.pdf              | 986040                                    | no | 7  |
|                     |                       |  | f4c0b9fdd3aec793ce37e5e511e1ac6deef9e8503 |    |    |
| <b>Warnings:</b>    |                       |  |   |    |    |
| <b>Information:</b> |                       |  |   |    |    |

|                     |                       |  |  |    |   |
|---------------------|-----------------------|--|--|----|---|
| 44                  | Non Patent Literature | Erceg_AnEmpiricallyBasedPathLossModel_.pdf | 1627477                                  | no | 7 |
|                     |                       |  | 236b5c988b07b977280ab53403d360ba72c01b6b |    |   |
| <b>Warnings:</b>    |                       |  |  |    |   |
| <b>Information:</b> |                       |  |  |    |   |
| 45                  | Non Patent Literature | Fujii_ExperimentalResearch_.pdf            | 812531                                   | no | 6 |
|                     |                       |  | 0cd8426bdb7986815c386ee6363212ce004a9e06 |    |   |
| <b>Warnings:</b>    |                       |  |  |    |   |
| <b>Information:</b> |                       |  |  |    |   |
| 46                  | Non Patent Literature | Knebelkamp_FieldTestOfCDMA System_.pdf     | 1087436                                  | no | 5 |
|                     |                       |  | 0381a6b3ae1e44bb8288528b8991b02840a97bc8 |    |   |
| <b>Warnings:</b>    |                       |  |  |    |   |
| <b>Information:</b> |                       |  |  |    |   |
| 47                  | Non Patent Literature | Li_PerformanceEvaluation_.pdf              | 1194502                                  | no | 9 |
|                     |                       |  | a6cba16f8ebf322f6189f6a63474966450cc0b9d |    |   |
| <b>Warnings:</b>    |                       |  |  |    |   |
| <b>Information:</b> |                       |  |  |    |   |
| 48                  | Non Patent Literature | Reed_AnOverviewOfChallenges_.pdf           | 4363337                                  | no | 8 |
|                     |                       |  | 55f6eefaced0cd0c302deaa846f58a2e2a3872b  |    |   |
| <b>Warnings:</b>    |                       |  |  |    |   |
| <b>Information:</b> |                       |  |  |    |   |
| 49                  | Non Patent Literature | Reudink_CellularNetworkDesign_.pdf         | 647297                                   | no | 4 |
|                     |                       |  | dbda3c609e7f03d39b51479b03766247d11e2543 |    |   |
| <b>Warnings:</b>    |                       |  |  |    |   |
| <b>Information:</b> |                       |  |  |    |   |
| 50                  | Non Patent Literature | Xia_RadioPropagation_.pdf                  | 1112350                                  | no | 9 |
|                     |                       |  | a1f2d309b96871c8a628699196fb60a1ed3b1307 |    |   |
| <b>Warnings:</b>    |                       |  |  |    |   |
| <b>Information:</b> |                       |  |  |    |   |



|                     |                       |  |   |    |   |
|---------------------|-----------------------|--|---|----|---|
| 51                  | Non Patent Literature | Batariere_WidebandMIMO_.pdf                    | 1297954                                   | no | 5 |
|                     |                       |  | c82cdeed7d2f7a0d80a9f4020c2781c334f176f78 |    |   |
| <b>Warnings:</b>    |                       |  |   |    |   |
| <b>Information:</b> |                       |  |   |    |   |
| 52                  | Non Patent Literature | Bin_FieldTestOfHTS_.pdf                        | 773938                                    | no | 4 |
|                     |                       |  | 3c6f6003f94f83ef8a271811fd8340c0398628f   |    |   |
| <b>Warnings:</b>    |                       |  |   |    |   |
| <b>Information:</b> |                       |  |   |    |   |
| 53                  | Non Patent Literature | Hyncica_UrbanVehicleToInfrast<br>ructure_.pdf  | 1560025                                   | no | 6 |
|                     |                       |  | cca98e7a9976c3584678147a05949914bd16ba3b  |    |   |
| <b>Warnings:</b>    |                       |  |   |    |   |
| <b>Information:</b> |                       |  |   |    |   |
| 54                  | Non Patent Literature | Imperatore_PathLossMeasure<br>ments_.pdf       | 1347100                                   | no | 8 |
|                     |                       |  | d5cb83de91966ffe05bc58f2e5636fa1d1f0d     |    |   |
| <b>Warnings:</b>    |                       |  |   |    |   |
| <b>Information:</b> |                       |  |   |    |   |
| 55                  | Non Patent Literature | Nilsson_MultipathPropagation<br>Simulator_.pdf | 1397968                                   | no | 5 |
|                     |                       |  | 036bc0cd6fd4e1594b9d95fb2ad1454b75d41bf   |    |   |
| <b>Warnings:</b>    |                       |  |   |    |   |
| <b>Information:</b> |                       |  |   |    |   |
| 56                  | Non Patent Literature | Riblett_FindingsOnTheSuitabili<br>ty_.pdf      | 1295525                                   | no | 7 |
|                     |                       |  | fd6130c532b799601361cc9f81c82262835aae8c  |    |   |
| <b>Warnings:</b>    |                       |  |   |    |   |
| <b>Information:</b> |                       |  |   |    |   |
| 57                  | Non Patent Literature | Schaffner_ADiveTestMeasure<br>ment_.pdf        | 721571                                    | no | 4 |
|                     |                       |  | 0521895055bf73a578912df277aed6a19c914f38  |    |   |
| <b>Warnings:</b>    |                       |  |   |    |   |
| <b>Information:</b> |                       |  |   |    |   |

|   |                       |  |   |           |   |
|---|-----------------------|--|---|-----------|---|
| 58  | Non Patent Literature | Schumacher_VehicleToVehicle_.pdf         | 1814510<br>a34b950a2ca45475522819ce61ce91ebf08a880b | no        | 5 |
| <b>Warnings:</b>  |                       |  |   |           |   |
| <b>Information:</b>   |                       |  |   |           |   |
| 59  | Non Patent Literature | Tao_AnOverviewOfCooperativ<br>eComm_.pdf | 1630721<br>28756bdeaf5a18021834cbabd59e3c1838456a3  | no        | 7 |
| <b>Warnings:</b>  |                       |  |   |           |   |
| <b>Information:</b>   |                       |  |   |           |   |
| 60  | Non Patent Literature | Xia_FieldOperationalTesting_.pdf         | 972176<br>3d30b5d462234cf1340feaf93826abba39ec6b5e  | no        | 6 |
| <b>Warnings:</b>  |                       |  |   |           |   |
| <b>Information:</b>   |                       |  |   |           |   |
| <b>Total Files Size (in bytes):</b>   |                       |  |   | 144041109 |   |
| <p><b>This Acknowledgement Receipt evidences receipt on the noted date by the USPTO of the indicated documents, characterized by the applicant, and including page counts, where applicable. It serves as evidence of receipt similar to a Post Card, as described in MPEP 503.</b></p> <p><b><u>New Applications Under 35 U.S.C. 111</u></b><br/> <b>If a new application is being filed and the application includes the necessary components for a filing date (see 37 CFR 1.53(b)-(d) and MPEP 506), a Filing Receipt (37 CFR 1.54) will be issued in due course and the date shown on this Acknowledgement Receipt will establish the filing date of the application.</b></p> <p><b><u>National Stage of an International Application under 35 U.S.C. 371</u></b><br/> <b>If a timely submission to enter the national stage of an international application is compliant with the conditions of 35 U.S.C. 371 and other applicable requirements a Form PCT/DO/EO/903 indicating acceptance of the application as a national stage submission under 35 U.S.C. 371 will be issued in addition to the Filing Receipt, in due course.</b></p> <p><b><u>New International Application Filed with the USPTO as a Receiving Office</u></b><br/> <b>If a new international application is being filed and the international application includes the necessary components for an international filing date (see PCT Article 11 and MPEP 1810), a Notification of the International Application Number and of the International Filing Date (Form PCT/RO/105) will be issued in due course, subject to prescriptions concerning national security, and the date shown on this Acknowledgement Receipt will establish the international filing date of the application.</b></p> |                       |  |   |           |   |

## Electronic Acknowledgement Receipt

|   |   |
|---|---|
| <b>EFS ID:</b>                              | 38656529  |
| <b>Application Number:</b>                  | 16788498  |
| <b>International Application Number:</b>    |   |
| <b>Confirmation Number:</b>                 | 8054  |
| <b>Title of Invention:</b>                  | MOBILE WIRELESS DEVICE PROVIDING OFF-LINE AND ON-LINE GEOGRAPHIC NAVIGATION INFORMATION |
| <b>First Named Inventor/Applicant Name:</b> | Mark Jefferson Reed   |
| <b>Customer Number:</b>                     | 59911   |
| <b>Filer:</b>                               | Andrew Mitchell Harris/Leigh Jones  |
| <b>Filer Authorized By:</b>                 | Andrew Mitchell Harris  |
| <b>Attorney Docket Number:</b>              | TX1000-C12  |
| <b>Receipt Date:</b>                        | 21-FEB-2020   |
| <b>Filing Date:</b>                         |   |
| <b>Time Stamp:</b>                          | 14:34:13  |
| <b>Application Type:</b>                    | Utility under 35 USC 111(a)   |

### Payment information:

|                        |    |
|------------------------|----|
| Submitted with Payment | no |
|------------------------|----|

### File Listing:

| Document Number | Document Description  | File Name                            | File Size(Bytes)/<br>Message Digest                   | Multi Part /.zip | Pages (if appl.) |
|-----------------|-----------------------|--------------------------------------|---|------------------|------------------|
| 1               | Non Patent Literature | Zhang_ApplicationOfDriveTest<br>_pdf | 724482<br><br>f9a9b1653cfc324ee79484f55ff00f2304e2d68 | no               | 4                |

### Warnings:

|                     |                       |  |   |    |    |
|---------------------|-----------------------|--|---|----|----|
| <b>Information:</b> |                       |  |   |    |    |
| 2                   | Non Patent Literature | Kubbar_MultipleAccessControl<br>Protocols_.pdf   | 2238374<br>3146e199a820fcd862baa226ed03996f830<br>00921 | no | 7  |
| <b>Warnings:</b>    |                       |  |   |    |    |
| <b>Information:</b> |                       |  |   |    |    |
| 3                   | Non Patent Literature | Naylon_LowLatency_.pdf                           | 1667398<br>5df6e4dc1c77853055e91179fbc3472f9cde<br>e19c | no | 13 |
| <b>Warnings:</b>    |                       |  |   |    |    |
| <b>Information:</b> |                       |  |   |    |    |
| 4                   | Non Patent Literature | Ramaswamy_PCSNetworkSurvivability_.pdf           | 1188220<br>39fd15d2207dfe07dd70994284003b23372<br>14162 | no | 5  |
| <b>Warnings:</b>    |                       |  |   |    |    |
| <b>Information:</b> |                       |  |   |    |    |
| 5                   | Non Patent Literature | Harter_ADistributedLocation_.pdf                 | 2592085<br>334797739d94e494957021d1c7b3fdb6e1e<br>033f9 | no | 9  |
| <b>Warnings:</b>    |                       |  |   |    |    |
| <b>Information:</b> |                       |  |   |    |    |
| 6                   | Non Patent Literature | TX1000-<br>C6_NoticeOfAllowance_11-21-<br>17.pdf | 567194<br>51fadab2a4d259c8eabdb38e3f3fbcacf47f<br>09a   | no | 43 |
| <b>Warnings:</b>    |                       |  |   |    |    |
| <b>Information:</b> |                       |  |   |    |    |
| 7                   | Non Patent Literature | TX1000-<br>C7_NoticeOfAllowance_12-13-<br>17.pdf | 383465<br>fe34090d064378b763ab054eb685cfcab74<br>e18dd  | no | 21 |
| <b>Warnings:</b>    |                       |  |   |    |    |
| <b>Information:</b> |                       |  |   |    |    |
| 8                   | Non Patent Literature | ListofPendingTraxcellLitigation<br>_06-28-18.pdf | 478225<br>63051c0be393244ccb466327eeb173503a8<br>ffe20  | no | 1  |
| <b>Warnings:</b>    |                       |  |   |    |    |
| <b>Information:</b> |                       |  |   |    |    |

|                     |                       |                                      |  |    |     |
|---------------------|-----------------------|--------------------------------------|--|----|-----|
| 9                   | Non Patent Literature | TX1000-C8_OfficeAction1_10-29-18.pdf | 116576                                   | no | 7   |
|                     |                       |                                      | be8cc77081e2cd604c8329890876052f57d2ea75 |    |     |
| <b>Warnings:</b>    |                       |                                      |  |    |     |
| <b>Information:</b> |                       |                                      |  |    |     |
| 10                  | Non Patent Literature | 3GPPTS25_433.pdf                     | 2348287                                  | no | 539 |
|                     |                       |                                      | a7afe376d8c2f78a217d24dc233e1a9161e88e9c |    |     |
| <b>Warnings:</b>    |                       |                                      |  |    |     |
| <b>Information:</b> |                       |                                      |  |    |     |
| 11                  | Non Patent Literature | Exhibit1009-Holma.pdf                | 3226474                                  | no | 74  |
|                     |                       |                                      | c9f29aa0b3abf05199a2c7a11e26a8df521336e  |    |     |
| <b>Warnings:</b>    |                       |                                      |  |    |     |
| <b>Information:</b> |                       |                                      |  |    |     |
| 12                  | Non Patent Literature | Exhibit1010-Prasad_PRN.pdf           | 8902499                                  | no | 28  |
|                     |                       |                                      | 3fa1e0bf857c70cac26237cbe383f525319f3cbe |    |     |
| <b>Warnings:</b>    |                       |                                      |  |    |     |
| <b>Information:</b> |                       |                                      |  |    |     |
| 13                  | Non Patent Literature | Exhibit1015-Andersson.pdf            | 2193220                                  | no | 23  |
|                     |                       |                                      | c6b44fbb66fda1aa475f98359e871519275be4d  |    |     |
| <b>Warnings:</b>    |                       |                                      |  |    |     |
| <b>Information:</b> |                       |                                      |  |    |     |
| 14                  | Non Patent Literature | Exhibit1016-Ojanpera_PRN.pdf         | 2224706                                  | no | 7   |
|                     |                       |                                      | 310b54c4f9bcfde1bc5c5609b46cbfa5967a26e1 |    |     |
| <b>Warnings:</b>    |                       |                                      |  |    |     |
| <b>Information:</b> |                       |                                      |  |    |     |
| 15                  | Non Patent Literature | Exhibit1017-3GPP_215.pdf             | 645446                                   | no | 17  |
|                     |                       |                                      | d70173bb5edf905c2f5198d95943488cc786db41 |    |     |
| <b>Warnings:</b>    |                       |                                      |  |    |     |
| <b>Information:</b> |                       |                                      |  |    |     |

|                     |                       |   |  |    |    |
|---------------------|-----------------------|---|--|----|----|
| 16                  | Non Patent Literature | Exhibit1018-3GPP_133.pdf                | 1047266                                  | no | 92 |
|                     |                       |   | a3e77741a0aa3772e833e16ff76ec9ad1189d830 |    |    |
| <b>Warnings:</b>    |                       |   |  |    |    |
| <b>Information:</b> |                       |   |  |    |    |
| 17                  | Non Patent Literature | Exhibit1019-Oetting.pdf                 | 1424600                                  | no | 6  |
|                     |                       |   | 52fa30090ce1bae19ab73a9c61ae00edff831e90 |    |    |
| <b>Warnings:</b>    |                       |   |  |    |    |
| <b>Information:</b> |                       |   |  |    |    |
| 18                  | Non Patent Literature | Exhibit1020-Rahnema.pdf                 | 1441298                                  | no | 9  |
|                     |                       |   | a27c8a3a82986db4fb61fe28da9eb8c41fd26d6b |    |    |
| <b>Warnings:</b>    |                       |   |  |    |    |
| <b>Information:</b> |                       |   |  |    |    |
| 19                  | Non Patent Literature | Exhibit1021-Lee.pdf                     | 1280369                                  | no | 12 |
|                     |                       |   | 15dccc9ee3a94d2b9a3e7e0000ee61490f1b2024 |    |    |
| <b>Warnings:</b>    |                       |   |  |    |    |
| <b>Information:</b> |                       |   |  |    |    |
| 20                  | Non Patent Literature | Exhibit1022-Pandya.pdf                  | 1156136                                  | no | 9  |
|                     |                       |   | 223a21511f1f67d75f982db2418b76d7cd37f63c |    |    |
| <b>Warnings:</b>    |                       |   |  |    |    |
| <b>Information:</b> |                       |   |  |    |    |
| 21                  | Non Patent Literature | Exhibit1023-Blecher.pdf                 | 3247270                                  | no | 9  |
|                     |                       |   | 74f6772a93b85b804382eb09fd9304d874d360e7 |    |    |
| <b>Warnings:</b>    |                       |   |  |    |    |
| <b>Information:</b> |                       |   |  |    |    |
| 22                  | Non Patent Literature | Exhibit1024-Shukla-1G2G3Gcomparison.pdf | 1136213                                  | no | 9  |
|                     |                       |   | fc082bc6d44cec8603b773056de39a69e086a459 |    |    |
| <b>Warnings:</b>    |                       |   |  |    |    |
| <b>Information:</b> |                       |   |  |    |    |

|                     |                       |                                 |  |    |    |
|---------------------|-----------------------|---------------------------------|--|----|----|
| 23                  | Non Patent Literature | Exhibit1025-Munoz-Rodriguez.pdf | 901347                                   | no | 4  |
|                     |                       |                                 | e81a40f6d8d0a3b691c2950282c6e9cc573d0385 |    |    |
| <b>Warnings:</b>    |                       |                                 |  |    |    |
| <b>Information:</b> |                       |                                 |  |    |    |
| 24                  | Non Patent Literature | Exhibit1028-Chiani.pdf          | 698964                                   | no | 7  |
|                     |                       |                                 | 4af508366eb1f514119b3696fb14d7499bac9016 |    |    |
| <b>Warnings:</b>    |                       |                                 |  |    |    |
| <b>Information:</b> |                       |                                 |  |    |    |
| 25                  | Non Patent Literature | Exhibit1031-Sweet.pdf           | 1362909                                  | no | 5  |
|                     |                       |                                 | 30d6464f7e88e24e94e534896a2f4d25b37f06bc |    |    |
| <b>Warnings:</b>    |                       |                                 |  |    |    |
| <b>Information:</b> |                       |                                 |  |    |    |
| 26                  | Non Patent Literature | Exhibit1033-RP-010003.pdf       | 1254659                                  | no | 56 |
|                     |                       |                                 | 469da94e3ca67c093c08ab3450e436c57e260b0  |    |    |
| <b>Warnings:</b>    |                       |                                 |  |    |    |
| <b>Information:</b> |                       |                                 |  |    |    |
| 27                  | Non Patent Literature | Exhibit1035-RP-000522.pdf       | 1148448                                  | no | 58 |
|                     |                       |                                 | 7a46d5c4e6d0921f1284103844c8fa0f30868089 |    |    |
| <b>Warnings:</b>    |                       |                                 |  |    |    |
| <b>Information:</b> |                       |                                 |  |    |    |
| 28                  | Non Patent Literature | Exhibit1037-RP-010283.pdf       | 1280889                                  | no | 78 |
|                     |                       |                                 | 20a6aac05b1eda392c2a2a23dcd4a9ac586d29d  |    |    |
| <b>Warnings:</b>    |                       |                                 |  |    |    |
| <b>Information:</b> |                       |                                 |  |    |    |
| 29                  | Non Patent Literature | Exhibit1029-Beller.pdf          | 1378935                                  | no | 9  |
|                     |                       |                                 | dcfda2f9f0898800e33352b2c0514c7160ed86d  |    |    |
| <b>Warnings:</b>    |                       |                                 |  |    |    |
| <b>Information:</b> |                       |                                 |  |    |    |

|                     |                       |   |   |    |    |
|---------------------|-----------------------|---|---|----|----|
| 30                  | Non Patent Literature | Exhibit1038-Perugini.pdf                                  | 1806799                                   | no | 12 |
|                     |                       |   | 5001bd0b48ebd675974ac49d192d23e5cf4c0eb2  |    |    |
| <b>Warnings:</b>    |                       |   |   |    |    |
| <b>Information:</b> |                       |   |   |    |    |
| 31                  | Non Patent Literature | Kaaranen_UMTSNetworks.pdf                                 | 664332                                    | no | 4  |
|                     |                       |   | 540a4a931c0c34e34699c29b966dc9419a3063fd  |    |    |
| <b>Warnings:</b>    |                       |   |   |    |    |
| <b>Information:</b> |                       |   |   |    |    |
| 32                  | Non Patent Literature | 3GPP_3GTS23_271_.pdf                                      | 863616                                    | no | 57 |
|                     |                       |   | 744ba86f892843cfeccfd26dee249832f54b7055a |    |    |
| <b>Warnings:</b>    |                       |   |   |    |    |
| <b>Information:</b> |                       |   |   |    |    |
| 33                  | Non Patent Literature | Huawei_NokiaClaimConstructionMemoandOrder.pdf             | 737577                                    | no | 34 |
|                     |                       |   | 52a69baed76907593b54b2270d4a6678e55a6d60  |    |    |
| <b>Warnings:</b>    |                       |   |   |    |    |
| <b>Information:</b> |                       |   |   |    |    |
| 34                  | Non Patent Literature | ATT_Verizon_Sprint_ClaimConstructionMemoandOrder.pdf      | 832627                                    | no | 58 |
|                     |                       |   | c09c5da587da1495c312429737646ff605ba83d3  |    |    |
| <b>Warnings:</b>    |                       |   |   |    |    |
| <b>Information:</b> |                       |   |   |    |    |
| 35                  | Non Patent Literature | ReportOnFilingOrDeterminationOfActionRePatent_ALE_USA.pdf | 26621                                     | no | 1  |
|                     |                       |   | 01a0ed741a22f540cc184cf72d22e6e7fdef1fd4  |    |    |
| <b>Warnings:</b>    |                       |   |   |    |    |
| <b>Information:</b> |                       |   |   |    |    |
| 36                  | Non Patent Literature | ReportOnFilingOrDeterminationOfActionRePatent_ATT.pdf     | 43988                                     | no | 1  |
|                     |                       |   | 142e7aee43e6dbbc6f8bdcb0055b855954be2477  |    |    |
| <b>Warnings:</b>    |                       |   |   |    |    |
| <b>Information:</b> |                       |   |   |    |    |



|                     |                       |  |  |    |   |
|---------------------|-----------------------|--|--|----|---|
| 37                  | Non Patent Literature | ReportOnFilingOrDeterminatio<br>nOfActionRePatent_Huawei.<br>pdf   | 26265<br>d8a96f9bb142b240811838c64bbb4f9f351<br>18ee0  | no | 1 |
| <b>Warnings:</b>    |                       |  |  |    |   |
| <b>Information:</b> |                       |  |  |    |   |
| 38                  | Non Patent Literature | ReportOnFilingOrDeterminatio<br>nOfActionRePatent_Motorola.<br>pdf | 26564<br>Bae70ecae864bf9b925e728469b3813decb<br>60585  | no | 1 |
| <b>Warnings:</b>    |                       |  |  |    |   |
| <b>Information:</b> |                       |  |  |    |   |
| 39                  | Non Patent Literature | ReportOnFilingOrDeterminatio<br>nOfActionRePatent_Nokia.pdf        | 26621<br>4d5b2017d995a5aa215a1b812d0fce9361<br>0b11f   | no | 1 |
| <b>Warnings:</b>    |                       |  |  |    |   |
| <b>Information:</b> |                       |  |  |    |   |
| 40                  | Non Patent Literature | ReportOnFilingOrDeterminatio<br>nOfActionRePatent_Samsung.<br>pdf  | 35295<br>ca00458fe03aa17e036dbdbeb563bebe63be<br>c1c8c | no | 1 |
| <b>Warnings:</b>    |                       |  |  |    |   |
| <b>Information:</b> |                       |  |  |    |   |
| 41                  | Non Patent Literature | ReportOnFilingOrDeterminatio<br>nOfActionRePatent_Sprint.pdf       | 23320<br>9a1f57f1f0d38352a4d9d67af10cdb977054<br>8de1  | no | 1 |
| <b>Warnings:</b>    |                       |  |  |    |   |
| <b>Information:</b> |                       |  |  |    |   |
| 42                  | Non Patent Literature | ReportOnFilingOrDeterminatio<br>nOfActionRePatent_TMmobile.<br>pdf | 22528<br>eb24c37d6f80677eb24481318f5e05935ed<br>03175  | no | 1 |
| <b>Warnings:</b>    |                       |  |  |    |   |
| <b>Information:</b> |                       |  |  |    |   |
| 43                  | Non Patent Literature | ReportOnFilingOrDeterminatio<br>nOfActionRePatent_Verizon.<br>pdf  | 23869<br>addee54897bb129b38484cbd216cf2bc142<br>e330a  | no | 1 |
| <b>Warnings:</b>    |                       |  |  |    |   |
| <b>Information:</b> |                       |  |  |    |   |

|                     |                       |   |  |    |     |
|---------------------|-----------------------|---|--|----|-----|
| 44                  | Non Patent Literature | HuaweiNokia_ORDERgrantings<br>ummaryjudgmentofnoninfring<br>ement.pdf | 604408<br>5e448dd738969e67ec23616955d9c9e240<br>697af    | no | 16  |
| <b>Warnings:</b>    |                       |   |  |    |     |
| <b>Information:</b> |                       |   |  |    |     |
| 45                  | Non Patent Literature | CHAKRABORTY_ADistributedAr<br>chitecture.pdf                          | 4116050<br>95c0abdd2a9f6920751da0c38adafd22822<br>9a486  | no | 58  |
| <b>Warnings:</b>    |                       |   |  |    |     |
| <b>Information:</b> |                       |   |  |    |     |
| 46                  | Non Patent Literature | GARMASH_GeographicXMLba<br>sedFormat.pdf                              | 1413413<br>d2eaa5ea37482fa52464c3fbcdf8d86f6b32<br>684a  | no | 9   |
| <b>Warnings:</b>    |                       |   |  |    |     |
| <b>Information:</b> |                       |   |  |    |     |
| 47                  | Non Patent Literature | WILLASSEN_MethodForImplem<br>entingMobileStationLocat<br>ion.pdf      | 5641791<br>05493e1c277c5fcb3b26c64c49fc835c5b7f6<br>bc3  | no | 74  |
| <b>Warnings:</b>    |                       |   |  |    |     |
| <b>Information:</b> |                       |   |  |    |     |
| 48                  | Non Patent Literature | LEONHARDI_ArchitectureForA<br>DistributedUniversalLocationSv<br>c.pdf | 1078625<br>fa8f7bff076a5db8d7f34526fa2d6ed431e56<br>8f3  | no | 6   |
| <b>Warnings:</b>    |                       |   |  |    |     |
| <b>Information:</b> |                       |   |  |    |     |
| 49                  | Non Patent Literature | HAN_EfficientLocationCacheSc<br>heme.pdf                              | 1269811<br>999f8ac9875bed1dd4da3d48470a22d96bd<br>bb0af1 | no | 9   |
| <b>Warnings:</b>    |                       |   |  |    |     |
| <b>Information:</b> |                       |   |  |    |     |
| 50                  | Non Patent Literature | BENEFON_OwnersManual_200<br>1.pdf                                     | 6483230<br>5ce966ce4739da6be98cb7c81c54885a255<br>32c13  | no | 169 |
| <b>Warnings:</b>    |                       |   |  |    |     |
| <b>Information:</b> |                       |   |  |    |     |

|                     |                       |   |   |    |     |
|---------------------|-----------------------|---|---|----|-----|
| 51                  | Non Patent Literature | BENEFON_OwnersManual_2002.pdf                   | 6174349                                   | no | 169 |
|                     |                       |   | cfdecad9fb6e42cd3b4912d604d2e8a278d4c989  |    |     |
| <b>Warnings:</b>    |                       |   |   |    |     |
| <b>Information:</b> |                       |   |   |    |     |
| 52                  | Non Patent Literature | CURSOR_TechnicalDetails.pdf                     | 233872                                    | no | 2   |
|                     |                       |   | 074e34929fdc81438e53feb9d10fad15fdbecabd5 |    |     |
| <b>Warnings:</b>    |                       |   |   |    |     |
| <b>Information:</b> |                       |   |   |    |     |
| 53                  | Non Patent Literature | CellularNetworkingPerspectives_November1999.pdf | 709514                                    | no | 6   |
|                     |                       |   | a24a75a2e1f5df3bd33cae990f1a643cea23e45   |    |     |
| <b>Warnings:</b>    |                       |   |   |    |     |
| <b>Information:</b> |                       |   |   |    |     |
| 54                  | Non Patent Literature | MADRIA_DataOrganizationIssues.pdf               | 1195142                                   | no | 18  |
|                     |                       |   | 6e1f52fee2ce0efe8ab04c6fd88ce703dcf0472   |    |     |
| <b>Warnings:</b>    |                       |   |   |    |     |
| <b>Information:</b> |                       |   |   |    |     |
| 55                  | Non Patent Literature | LAITINEN_DatabaseCorrelationMethod.pdf          | 521816                                    | no | 6   |
|                     |                       |   | 557889e84138452aa164bc8117e1b897056c27af  |    |     |
| <b>Warnings:</b>    |                       |   |   |    |     |
| <b>Information:</b> |                       |   |   |    |     |
| 56                  | Non Patent Literature | SAWIDES_DynamicFine-GrainedLocalization.pdf     | 1813070                                   | no | 15  |
|                     |                       |   | 5c0074fb122fa6a1ee364083809cb45f8b368263  |    |     |
| <b>Warnings:</b>    |                       |   |   |    |     |
| <b>Information:</b> |                       |   |   |    |     |
| 57                  | Non Patent Literature | MARKKULA_DynamicGeographicPersonalData.pdf      | 1292339                                   | no | 9   |
|                     |                       |   | 524ca16b3242210da015b353c002415fe5a86593  |    |     |
| <b>Warnings:</b>    |                       |   |   |    |     |
| <b>Information:</b> |                       |   |   |    |     |

|   |                       |  |  |          |    |
|---|-----------------------|--|--|----------|----|
| 58  | Non Patent Literature | WANG_E-911LocationStandards.pdf                | 568067<br>bfe7cb5bc34efe143d148568b1740ece06298ed9 | no       | 6  |
| <b>Warnings:</b>  |                       |  |  |          |    |
| <b>Information:</b>   |                       |  |  |          |    |
| 59  | Non Patent Literature | ETSI_EuropeanDigitalCellularTelecommSystem.pdf | 529868<br>b2b746271c09f281e46a0d3b117fac166fbcb6b  | no       | 11 |
| <b>Warnings:</b>  |                       |  |  |          |    |
| <b>Information:</b>   |                       |  |  |          |    |
| 60  | Non Patent Literature | ETSI_DigitalCellularTelecommSystem_Nov1996.pdf | 517016<br>58102a7b82acb44d62e88c1db7d472746ba703c1 | no       | 11 |
| <b>Warnings:</b>  |                       |  |  |          |    |
| <b>Information:</b>   |                       |  |  |          |    |
| <b>Total Files Size (in bytes):</b>   |                       |  |  | 87578357 |    |
| <p><b>This Acknowledgement Receipt evidences receipt on the noted date by the USPTO of the indicated documents, characterized by the applicant, and including page counts, where applicable. It serves as evidence of receipt similar to a Post Card, as described in MPEP 503.</b></p> <p><b><u>New Applications Under 35 U.S.C. 111</u></b><br/> <b>If a new application is being filed and the application includes the necessary components for a filing date (see 37 CFR 1.53(b)-(d) and MPEP 506), a Filing Receipt (37 CFR 1.54) will be issued in due course and the date shown on this Acknowledgement Receipt will establish the filing date of the application.</b></p> <p><b><u>National Stage of an International Application under 35 U.S.C. 371</u></b><br/> <b>If a timely submission to enter the national stage of an international application is compliant with the conditions of 35 U.S.C. 371 and other applicable requirements a Form PCT/DO/EO/903 indicating acceptance of the application as a national stage submission under 35 U.S.C. 371 will be issued in addition to the Filing Receipt, in due course.</b></p> <p><b><u>New International Application Filed with the USPTO as a Receiving Office</u></b><br/> <b>If a new international application is being filed and the international application includes the necessary components for an international filing date (see PCT Article 11 and MPEP 1810), a Notification of the International Application Number and of the International Filing Date (Form PCT/RO/105) will be issued in due course, subject to prescriptions concerning national security, and the date shown on this Acknowledgement Receipt will establish the international filing date of the application.</b></p> |                       |  |  |          |    |

## Electronic Acknowledgement Receipt

|   |   |
|---|---|
| <b>EFS ID:</b>                              | 38657038  |
| <b>Application Number:</b>                  | 16788498  |
| <b>International Application Number:</b>    |   |
| <b>Confirmation Number:</b>                 | 8054  |
| <b>Title of Invention:</b>                  | MOBILE WIRELESS DEVICE PROVIDING OFF-LINE AND ON-LINE GEOGRAPHIC NAVIGATION INFORMATION |
| <b>First Named Inventor/Applicant Name:</b> | Mark Jefferson Reed   |
| <b>Customer Number:</b>                     | 59911   |
| <b>Filer:</b>                               | Andrew Mitchell Harris/Leigh Jones  |
| <b>Filer Authorized By:</b>                 | Andrew Mitchell Harris  |
| <b>Attorney Docket Number:</b>              | TX1000-C12  |
| <b>Receipt Date:</b>                        | 21-FEB-2020   |
| <b>Filing Date:</b>                         |   |
| <b>Time Stamp:</b>                          | 14:52:04  |
| <b>Application Type:</b>                    | Utility under 35 USC 111(a)   |

### Payment information:

|                        |    |
|------------------------|----|
| Submitted with Payment | no |
|------------------------|----|

### File Listing:

| Document Number | Document Description  | File Name  | File Size(Bytes)/<br>Message Digest                                | Multi Part /.zip | Pages (if appl.) |
|-----------------|-----------------------|--|--|------------------|------------------|
| 1               | Non Patent Literature | ETSI_DigitalCellularTelecommunicationsSystem.pdf | 7726117<br><small>ea1070fe4e56c4378e51edca463c08378b9007e5</small> | no               | 107              |

### Warnings:

|                     |                       |   |   |    |    |
|---------------------|-----------------------|---|---|----|----|
| <b>Information:</b> |                       |   |   |    |    |
| 2                   | Non Patent Literature | Djuknic_GeolocationAndAssistedGPS.pdf             | 690062<br>6177a5b35f74ca01c6b8c67361f9f4807252616c  | no | 3  |
| <b>Warnings:</b>    |                       |   |   |    |    |
| <b>Information:</b> |                       |   |   |    |    |
| 3                   | Non Patent Literature | GSM_DigitalCellularTelecommunicationsSystems_.pdf | 1207981<br>79b550d9d84a957d796c2731ee7e19762bda9ed1 | no | 11 |
| <b>Warnings:</b>    |                       |   |   |    |    |
| <b>Information:</b> |                       |   |   |    |    |
| 4                   | Non Patent Literature | GlobalSystemforMobileCommunicationGSM.pdf         | 1324893<br>bb362a66a48ca84b0544d0507975c780e1694bd8 | no | 19 |
| <b>Warnings:</b>    |                       |   |   |    |    |
| <b>Information:</b> |                       |   |   |    |    |
| 5                   | Non Patent Literature | DRANE_PositioningGSMTelephones.pdf                | 2555989<br>b02c9bb8e5e41cdae08b4ef832dceee8b7abeaf0 | no | 10 |
| <b>Warnings:</b>    |                       |   |   |    |    |
| <b>Information:</b> |                       |   |   |    |    |
| 6                   | Non Patent Literature | PANAGIOTAKIS_IntegratedGenericArchitecture.pdf    | 840929<br>b2e4040618aed4f1030e1e6c4375ae1e4480667a  | no | 5  |
| <b>Warnings:</b>    |                       |   |   |    |    |
| <b>Information:</b> |                       |   |   |    |    |
| 7                   | Non Patent Literature | BISWAS_LeveragingLocationBasedServices.pdf        | 1164194<br>d29b1857976f380d755f2d83e77bb20d70564fcc | no | 19 |
| <b>Warnings:</b>    |                       |   |   |    |    |
| <b>Information:</b> |                       |   |   |    |    |
| 8                   | Non Patent Literature | JANA_LocationBasedServices.pdf                    | 1022139<br>c3b83da4ea325fa1db9663580143016a2d7a3ceb | no | 7  |
| <b>Warnings:</b>    |                       |   |   |    |    |
| <b>Information:</b> |                       |   |   |    |    |

|                     |                       |   |   |    |    |
|---------------------|-----------------------|---|---|----|----|
| 9                   | Non Patent Literature | Leonhardt_LocationServiceInM<br>obileComputing.pdf    | 929282  | no | 6  |
|                     |                       |   | 0a78dd551873c60031e1eb3fa8ee07b4ecfa0<br>a2d5 |    |    |
| <b>Warnings:</b>    |                       |   |   |    |    |
| <b>Information:</b> |                       |   |   |    |    |
| 10                  | Non Patent Literature | STEER_LocationServicesArchite<br>cture.pdf            | 620005  | no | 5  |
|                     |                       |   | b3b98c8179f7e784e3be5874e15e8659d53<br>e3f33  |    |    |
| <b>Warnings:</b>    |                       |   |   |    |    |
| <b>Information:</b> |                       |   |   |    |    |
| 11                  | Non Patent Literature | KOPPEL_LocationServicesAreH<br>ere.pdf                | 413028  | no | 3  |
|                     |                       |   | 12828dfe33348438e30c38339a04b9f1e5d<br>ddfe   |    |    |
| <b>Warnings:</b>    |                       |   |   |    |    |
| <b>Information:</b> |                       |   |   |    |    |
| 12                  | Non Patent Literature | PHONECOM_PhoneComAndSn<br>aptrackTeam.pdf             | 852222  | no | 5  |
|                     |                       |   | db64007b56f564df8f4b6a6f5b6f1db4f146<br>3bd4  |    |    |
| <b>Warnings:</b>    |                       |   |   |    |    |
| <b>Information:</b> |                       |   |   |    |    |
| 13                  | Non Patent Literature | Webraska_PhoneComAndWeb<br>raskaPartner.pdf           | 612967  | no | 4  |
|                     |                       |   | b178473cfd4ba51346d1f72894ad9977954<br>5e123  |    |    |
| <b>Warnings:</b>    |                       |   |   |    |    |
| <b>Information:</b> |                       |   |   |    |    |
| 14                  | Non Patent Literature | ZAGAMI_ProvidingUniversalLo<br>cationServices.pdf     | 2914149                                       | no | 6  |
|                     |                       |   | 966c7c79442426c06ae3b4557622eb2aa12<br>98f1f  |    |    |
| <b>Warnings:</b>    |                       |   |   |    |    |
| <b>Information:</b> |                       |   |   |    |    |
| 15                  | Non Patent Literature | JOSE_ScalableAndFlexibleLoca<br>tionBasedServices.pdf | 1058617                                       | no | 15 |
|                     |                       |   | 440f99fb1914b47f596056f4107910c9d500<br>70f   |    |    |
| <b>Warnings:</b>    |                       |   |   |    |    |
| <b>Information:</b> |                       |   |   |    |    |

|                     |                       |   |  |    |     |
|---------------------|-----------------------|---|--|----|-----|
| 16                  | Non Patent Literature | KESDOGAN_SecureLocationInfo.pdf               | 856874                                   | no | 7   |
|                     |                       |   | 2d3858977a14b157d8786f869034ca14097b012  |    |     |
| <b>Warnings:</b>    |                       |   |  |    |     |
| <b>Information:</b> |                       |   |  |    |     |
| 17                  | Non Patent Literature | ETSI_ChangesToLCSForMOPosition.pdf            | 2997748                                  | no | 40  |
|                     |                       |   | 17fa39bd433cf4092e41cf6dd4f819da17d1a2b6 |    |     |
| <b>Warnings:</b>    |                       |   |  |    |     |
| <b>Information:</b> |                       |   |  |    |     |
| 18                  | Non Patent Literature | USWirelessCorp_TeleavigationPartners.pdf      | 462744                                   | no | 3   |
|                     |                       |   | b79fd0beacfb02a02cb3b31afca7879bd999900  |    |     |
| <b>Warnings:</b>    |                       |   |  |    |     |
| <b>Information:</b> |                       |   |  |    |     |
| 19                  | Non Patent Literature | BloorResearch_TheBloorPerspective.pdf         | 289832                                   | no | 2   |
|                     |                       |   | 48450f83d283c841c978623ab15b37e9456dc4b  |    |     |
| <b>Warnings:</b>    |                       |   |  |    |     |
| <b>Information:</b> |                       |   |  |    |     |
| 20                  | Non Patent Literature | USDOT_TravTekSystemArchitectureEvaluation.pdf | 11668657                                 | no | 156 |
|                     |                       |   | 32f0217bd84c2fff726d76218beceeead0ebc32  |    |     |
| <b>Warnings:</b>    |                       |   |  |    |     |
| <b>Information:</b> |                       |   |  |    |     |
| 21                  | Non Patent Literature | ETSI_UniversalMobileTelecomSystem.pdf         | 4314871                                  | no | 53  |
|                     |                       |   | bea562cf2f51099ef581e3c343d73d93f529b78e |    |     |
| <b>Warnings:</b>    |                       |   |  |    |     |
| <b>Information:</b> |                       |   |  |    |     |
| 22                  | Non Patent Literature | Turner_TravelTimeDataCollectionHandbook.pdf   | 25989429                                 | no | 341 |
|                     |                       |   | acaa1902d8d29f9056adc955467db1e2d196ecea |    |     |
| <b>Warnings:</b>    |                       |   |  |    |     |
| <b>Information:</b> |                       |   |  |    |     |



|                     |                       |   |   |    |     |
|---------------------|-----------------------|---|---|----|-----|
| 23                  | Non Patent Literature | Webraska_OrangeSwitzerland.pdf                                      | 539871<br>25512786d3558dd426b3dff5b5f5b235ff9d438d5 | no | 4   |
| <b>Warnings:</b>    |                       |   |   |    |     |
| <b>Information:</b> |                       |   |   |    |     |
| 24                  | Non Patent Literature | GARMIN_NavTalk.pdf  | 7712050<br>683c9adba116180697e4f0e006b6b468c8df6e9b | no | 128 |
| <b>Warnings:</b>    |                       |   |   |    |     |
| <b>Information:</b> |                       |   |   |    |     |
| 25                  | Non Patent Literature | TX1000-C8_NoticeOfAllowance_06-24-19.pdf                            | 810256<br>6b1ce9db364d1fa12a32d05bd20a10dc119970a3  | no | 14  |
| <b>Warnings:</b>    |                       |   |   |    |     |
| <b>Information:</b> |                       |   |   |    |     |
| 26                  | Non Patent Literature | GSM_DigitalCellularTelecommunicationsSystems_GeneralPacketRadio.pdf | 845616<br>89a83b51e3c0565ed2c2ab185e86997b028e433   | no | 117 |
| <b>Warnings:</b>    |                       |   |   |    |     |
| <b>Information:</b> |                       |   |   |    |     |
| 27                  | Non Patent Literature | LAITINEN_CellularNetworkOptimisation.pdf                            | 3363472<br>f2d5ca455ffed6da7d2c64db1f99afd9cb35d87  | no | 51  |
| <b>Warnings:</b>    |                       |   |   |    |     |
| <b>Information:</b> |                       |   |   |    |     |
| 28                  | Non Patent Literature | FCC_RevisionToCommissionsRules_ReportAndOrderAndFurtherNotice.pdf   | 3864805<br>51d41b2eae171d84cbd7e9a9278581ba18b1cb51 | no | 48  |
| <b>Warnings:</b>    |                       |   |   |    |     |
| <b>Information:</b> |                       |   |   |    |     |
| 29                  | Non Patent Literature | FTC_TheMobileWirelessWeb.pdf  | 67925<br>cd1c405056989126bbe0e58988d21c0cf233d5     | no | 1   |
| <b>Warnings:</b>    |                       |   |   |    |     |
| <b>Information:</b> |                       |   |   |    |     |

|                     |                       |  |   |    |     |
|---------------------|-----------------------|--|---|----|-----|
| 30                  | Non Patent Literature | FTC_MillerResponseStatement.pdf                        | 1034494<br>aacceeu5296e5d2f79603ba9ff375c0ff29ef730   | no | 12  |
| <b>Warnings:</b>    |                       |  |   |    |     |
| <b>Information:</b> |                       |  |   |    |     |
| 31                  | Non Patent Literature | FTC_TheMobileWirelessWeb_Agenda.pdf                    | 279837<br>78e2a0ff96526c688ef78e8347315a7d48e0380c    | no | 3   |
| <b>Warnings:</b>    |                       |  |   |    |     |
| <b>Information:</b> |                       |  |   |    |     |
| 32                  | Non Patent Literature | FTC_TheMobileWirelessWebConferenceProceedings_Vol1.pdf | 5849785<br>4c2e0f08e7568e7c79b0a28ac7ab298428ada297   | no | 59  |
| <b>Warnings:</b>    |                       |  |   |    |     |
| <b>Information:</b> |                       |  |   |    |     |
| 33                  | Non Patent Literature | FTC_TheMobileWirelessWebConferenceProceedings_Vol2.pdf | 9573747<br>a8d2ecd74f3bbb978c579d5ce70327b63fba8bfc   | no | 97  |
| <b>Warnings:</b>    |                       |  |   |    |     |
| <b>Information:</b> |                       |  |   |    |     |
| 34                  | Non Patent Literature | ASCHE_TheOmegaSystem.pdf                               | 1949427<br>5bab652c5ef303083d1e2855d899663c80b5bcd1   | no | 13  |
| <b>Warnings:</b>    |                       |  |   |    |     |
| <b>Information:</b> |                       |  |   |    |     |
| 35                  | Non Patent Literature | KERNIGHAN_CProgrammingLanguage.pdf                     | 26126845<br>b141d8535508fdcf7f7977e0b3796e02af451480e | no | 288 |
| <b>Warnings:</b>    |                       |  |   |    |     |
| <b>Information:</b> |                       |  |   |    |     |
| 36                  | Non Patent Literature | Rappaport_WirelessCommunications_pt1.pdf               | 20102277<br>e9e52bb5a58f2fcc624d57c0ff81af6fed9b5d0   | no | 300 |
| <b>Warnings:</b>    |                       |  |   |    |     |
| <b>Information:</b> |                       |  |   |    |     |

|   |                       |   |  |           |     |
|---|-----------------------|---|--|-----------|-----|
| 37  | Non Patent Literature | Rappaport_WirelessCommunications_pt2.pdf    | 22987382<br>fc472cc29e08e37a030f08aacfec229789333c99 | no        | 339 |
| <b>Warnings:</b>  |                       |   |  |           |     |
| <b>Information:</b>   |                       |   |  |           |     |
| 38  | Non Patent Literature | ETSI_ReleaseNote_RecommendationGSM06-10.pdf | 2874969<br>ec8f629cfc5827b9f874d5f7040ce4d5fa5743c   | no        | 95  |
| <b>Warnings:</b>  |                       |   |  |           |     |
| <b>Information:</b>   |                       |   |  |           |     |
| 39  | Non Patent Literature | TX1000-C9_NoticeOfAllowance_08-22-19.pdf    | 1214285<br>ceb6a119ec2c8f13f5454166e89e6a74f0cb390f  | no        | 64  |
| <b>Warnings:</b>  |                       |   |  |           |     |
| <b>Information:</b>   |                       |   |  |           |     |
| <b>Total Files Size (in bytes):</b>   |                       |   |  | 179709772 |     |
| <p><b>This Acknowledgement Receipt evidences receipt on the noted date by the USPTO of the indicated documents, characterized by the applicant, and including page counts, where applicable. It serves as evidence of receipt similar to a Post Card, as described in MPEP 503.</b></p> <p><b><u>New Applications Under 35 U.S.C. 111</u></b><br/> <b>If a new application is being filed and the application includes the necessary components for a filing date (see 37 CFR 1.53(b)-(d) and MPEP 506), a Filing Receipt (37 CFR 1.54) will be issued in due course and the date shown on this Acknowledgement Receipt will establish the filing date of the application.</b></p> <p><b><u>National Stage of an International Application under 35 U.S.C. 371</u></b><br/> <b>If a timely submission to enter the national stage of an international application is compliant with the conditions of 35 U.S.C. 371 and other applicable requirements a Form PCT/DO/EO/903 indicating acceptance of the application as a national stage submission under 35 U.S.C. 371 will be issued in addition to the Filing Receipt, in due course.</b></p> <p><b><u>New International Application Filed with the USPTO as a Receiving Office</u></b><br/> <b>If a new international application is being filed and the international application includes the necessary components for an international filing date (see PCT Article 11 and MPEP 1810), a Notification of the International Application Number and of the International Filing Date (Form PCT/RO/105) will be issued in due course, subject to prescriptions concerning national security, and the date shown on this Acknowledgement Receipt will establish the international filing date of the application.</b></p> |                       |   |  |           |     |



# United States Patent and Trademark Office

*Office of the Chief Financial Officer*

Document Code:WFEE

User :C46153

Sale Accounting Date:04/15/2020

---

| Sale Item Reference Number | Effective Date |
|----------------------------|----------------|
| 16788498                   | 02/12/2020     |

| Document Number  | Fee Code | Fee Code Description                       | Amount Paid | Payment Method  |
|------------------|----------|--|-------------|-----------------|
| I20204EC22041461 | 2051     | LATE FILING FEE FOR OATH OR<br>DECLARATION | \$80.00     | Deposit Account |



UNITED STATES PATENT AND TRADEMARK OFFICE

UNITED STATES DEPARTMENT OF COMMERCE
United States Patent and Trademark Office
Address: COMMISSIONER FOR PATENTS
P.O. Box 1450
Alexandria, Virginia 22313-1450
www.uspto.gov

Table with 7 columns: APPLICATION NUMBER, FILING or 371(c) DATE, GRP ART UNIT, FIL FEE REC'D, ATTY.DOCKET.NO, TOT CLAIMS, IND CLAIMS. Values: 16/788,498, 02/12/2020, 1965, TX1000-C12, 30, 3

CONFIRMATION NO. 8054

FILING RECEIPT



59911
MITCH HARRIS, LLC - GENERAL
P.O. BOX 1269
ATHENS, GA 30603-1269

Date Mailed: 04/15/2020

Receipt is acknowledged of this non-provisional utility patent application. The application will be taken up for examination in due course. Applicant will be notified as to the results of the examination. Any correspondence concerning the application must include the following identification information: the U.S. APPLICATION NUMBER, FILING DATE, NAME OF FIRST INVENTOR, and TITLE OF INVENTION. Fees transmitted by check or draft are subject to collection.

Please verify the accuracy of the data presented on this receipt. If an error is noted on this Filing Receipt, please submit a written request for a corrected Filing Receipt, including a properly marked-up ADS showing the changes with strike-through for deletions and underlining for additions. If you received a "Notice to File Missing Parts" or other Notice requiring a response for this application, please submit any request for correction to this Filing Receipt with your reply to the Notice. When the USPTO processes the reply to the Notice, the USPTO will generate another Filing Receipt incorporating the requested corrections provided that the request is grantable.

Inventor(s)

Mark Jefferson Reed, Tucson, AZ;
Stephen Michael Palik, Redondo Beach, CA;

Applicant(s)

Traxcell Technologies, LLC, Plano, TX;

Power of Attorney: The patent practitioners associated with Customer Number 59911

Domestic Priority data as claimed by applicant

This application is a CON of 16/557,277 08/30/2019
which is a CON of 16/116,215 08/29/2018 PAT 10448209
which is a CON of 15/880,852 01/26/2018 PAT 10390175
which is a CON of 15/717,138 09/27/2017 PAT 9918196
which is a CON of 15/468,265 03/24/2017 PAT 9888353
which is a CON of 15/297,222 10/19/2016 PAT 9642024
which is a CON of 14/642,408 03/09/2015 PAT 9510320
which is a CON of 11/505,578 08/17/2006 PAT 8977284
which is a CIP of 10/255,552 09/24/2002 ABN
which claims benefit of 60/383,528 05/28/2002
and claims benefit of 60/352,761 01/29/2002
and claims benefit of 60/335,203 10/23/2001
and claims benefit of 60/383,529 05/28/2002
and claims benefit of 60/391,469 06/26/2002
and claims benefit of 60/353,379 01/30/2002

and claims benefit of 60/381,249 05/16/2002  
and claims benefit of 60/327,327 10/04/2001

**Foreign Applications** for which priority is claimed (You may be eligible to benefit from the **Patent Prosecution Highway** program at the USPTO. Please see <http://www.uspto.gov> for more information.) - None.

*Foreign application information must be provided in an Application Data Sheet in order to constitute a claim to foreign priority. See 37 CFR 1.55 and 1.76.*

**Permission to Access Application via Priority Document Exchange:** Yes

**Permission to Access Search Results:** Yes

Applicant may provide or rescind an authorization for access using Form PTO/SB/39 or Form PTO/SB/69 as appropriate.

**If Required, Foreign Filing License Granted:** 04/15/2020

The country code and number of your priority application, to be used for filing abroad under the Paris Convention, is **US 16/788,498**

**Projected Publication Date:** 07/23/2020

**Non-Publication Request:** No

**Early Publication Request:** No

**\*\* SMALL ENTITY \*\***

**Title**

MOBILE WIRELESS DEVICE PROVIDING OFF-LINE AND ON-LINE GEOGRAPHIC NAVIGATION  
INFORMATION

**Preliminary Class**

**Statement under 37 CFR 1.55 or 1.78 for AIA (First Inventor to File) Transition Applications:** No

## **PROTECTING YOUR INVENTION OUTSIDE THE UNITED STATES**

Since the rights granted by a U.S. patent extend only throughout the territory of the United States and have no effect in a foreign country, an inventor who wishes patent protection in another country must apply for a patent in a specific country or in regional patent offices. Applicants may wish to consider the filing of an international application under the Patent Cooperation Treaty (PCT). An international (PCT) application generally has the same effect as a regular national patent application in each PCT-member country. The PCT process **simplifies** the filing of patent applications on the same invention in member countries, but **does not result** in a grant of "an international patent" and does not eliminate the need of applicants to file additional documents and fees in countries where patent protection is desired.

Almost every country has its own patent law, and a person desiring a patent in a particular country must make an application for patent in that country in accordance with its particular laws. Since the laws of many countries differ in various respects from the patent law of the United States, applicants are advised to seek guidance from specific foreign countries to ensure that patent rights are not lost prematurely.

Applicants also are advised that in the case of inventions made in the United States, the Director of the USPTO must issue a license before applicants can apply for a patent in a foreign country. The filing of a U.S. patent application

page 2 of 4

serves as a request for a foreign filing license. The application's filing receipt contains further information and guidance as to the status of applicant's license for foreign filing.

Applicants may wish to consult the USPTO booklet, "General Information Concerning Patents" (specifically, the section entitled "Treaties and Foreign Patents") for more information on timeframes and deadlines for filing foreign patent applications. The guide is available either by contacting the USPTO Contact Center at 800-786-9199, or it can be viewed on the USPTO website at <http://www.uspto.gov/web/offices/pac/doc/general/index.html>.

For information on preventing theft of your intellectual property (patents, trademarks and copyrights), you may wish to consult the U.S. Government website, <http://www.stopfakes.gov>. Part of a Department of Commerce initiative, this website includes self-help "toolkits" giving innovators guidance on how to protect intellectual property in specific countries such as China, Korea and Mexico. For questions regarding patent enforcement issues, applicants may call the U.S. Government hotline at 1-866-999-HALT (1-866-999-4258).

**LICENSE FOR FOREIGN FILING UNDER  
Title 35, United States Code, Section 184  
Title 37, Code of Federal Regulations, 5.11 & 5.15**

**GRANTED**

The applicant has been granted a license under 35 U.S.C. 184, if the phrase "IF REQUIRED, FOREIGN FILING LICENSE GRANTED" followed by a date appears on this form. Such licenses are issued in all applications where the conditions for issuance of a license have been met, regardless of whether or not a license may be required as set forth in 37 CFR 5.15. The scope and limitations of this license are set forth in 37 CFR 5.15(a) unless an earlier license has been issued under 37 CFR 5.15(b). The license is subject to revocation upon written notification. The date indicated is the effective date of the license, unless an earlier license of similar scope has been granted under 37 CFR 5.13 or 5.14.

This license is to be retained by the licensee and may be used at any time on or after the effective date thereof unless it is revoked. This license is automatically transferred to any related applications(s) filed under 37 CFR 1.53(d). This license is not retroactive.

The grant of a license does not in any way lessen the responsibility of a licensee for the security of the subject matter as imposed by any Government contract or the provisions of existing laws relating to espionage and the national security or the export of technical data. Licensees should apprise themselves of current regulations especially with respect to certain countries, of other agencies, particularly the Office of Defense Trade Controls, Department of State (with respect to Arms, Munitions and Implements of War (22 CFR 121-128)); the Bureau of Industry and Security, Department of Commerce (15 CFR parts 730-774); the Office of Foreign Assets Control, Department of Treasury (31 CFR Parts 500+) and the Department of Energy.

**NOT GRANTED**

No license under 35 U.S.C. 184 has been granted at this time, if the phrase "IF REQUIRED, FOREIGN FILING LICENSE GRANTED" DOES NOT appear on this form. Applicant may still petition for a license under 37 CFR 5.12, if a license is desired before the expiration of 6 months from the filing date of the application. If 6 months has lapsed from the filing date of this application and the licensee has not received any indication of a secrecy order under 35 U.S.C. 181, the licensee may foreign file the application pursuant to 37 CFR 5.15(b).

---

## **SelectUSA**

The United States represents the largest, most dynamic marketplace in the world and is an unparalleled location for business investment, innovation, and commercialization of new technologies. The U.S. offers tremendous resources and advantages for those who invest and manufacture goods here. Through SelectUSA, our nation works to promote and facilitate business investment. SelectUSA provides information assistance to the international investor community; serves as an ombudsman for existing and potential investors; advocates on behalf of U.S. cities, states, and regions competing for global investment; and counsels U.S. economic development organizations on investment attraction best practices. To learn more about why the United States is the best country in the world to develop technology, manufacture products, deliver services, and grow your business, visit <http://www.SelectUSA.gov> or call +1-202-482-6800.



| <b>PATENT APPLICATION FEE DETERMINATION RECORD</b>  |   |                                  |       |                                    |                 | Application or Docket Number<br>16/788,498 |                    |                               |                    |  |
|---|---|----------------------------------|-------|------------------------------------|-----------------|--|--------------------|-------------------------------|--------------------|--|
| Substitute for Form PTO-875   |   |                                  |       |                                    |                 |  |                    |                               |                    |  |
| <b>APPLICATION AS FILED - PART I</b>  |   |                                  |       |                                    |                 |  |                    |                               |                    |  |
| (Column 1)  |   | (Column 2)                       |       | SMALL ENTITY                       |                 | OR<br>OTHER THAN SMALL ENTITY              |                    |                               |                    |  |
| FOR   | NUMBER FILED  | NUMBER EXTRA                     |       | RATE(\$)                           | FEE(\$)         | RATE(\$)                                   | FEE(\$)            |                               |                    |  |
| BASIC FEE<br><small>(37 CFR 1.16(a), (b), or (c))</small>   | N/A   | N/A                              |       | N/A                                | 75              | N/A  |                    |                               |                    |  |
| SEARCH FEE<br><small>(37 CFR 1.16(k), (l), or (m))</small>  | N/A   | N/A                              |       | N/A                                | 330             | N/A  |                    |                               |                    |  |
| EXAMINATION FEE<br><small>(37 CFR 1.16(o), (p), or (q))</small>   | N/A   | N/A                              |       | N/A                                | 380             | N/A  |                    |                               |                    |  |
| TOTAL CLAIMS<br><small>(37 CFR 1.16(i))</small>   | 30  | minus 20 = *                     | 10    | x 50 =                             | 500             | OR   |                    |                               |                    |  |
| INDEPENDENT CLAIMS<br><small>(37 CFR 1.16(h))</small>   | 3   | minus 3 = *                      |       | x 230 =                            | 0.00            |  |                    |                               |                    |  |
| APPLICATION SIZE FEE<br><small>(37 CFR 1.16(s))</small>   | If the specification and drawings exceed 100 sheets of paper, the application size fee due is \$310 (\$155 for small entity) for each additional 50 sheets or fraction thereof. See 35 U.S.C. 41(a)(1)(G) and 37 CFR 1.16(s). |                                  |       |                                    | 600             |  |                    |                               |                    |  |
| MULTIPLE DEPENDENT CLAIM PRESENT <small>(37 CFR 1.16(j))</small>  |   |                                  |       |                                    | 0.00            |  |                    |                               |                    |  |
| * If the difference in column 1 is less than zero, enter "0" in column 2.   |   |                                  |       | TOTAL                              | 1885            | TOTAL                                      |                    |                               |                    |  |
| <b>APPLICATION AS AMENDED - PART II</b>   |   |                                  |       |                                    |                 |  |                    |                               |                    |  |
| (Column 1)  |   | (Column 2)                       |       | (Column 3)                         |                 | SMALL ENTITY                               |                    | OR<br>OTHER THAN SMALL ENTITY |                    |  |
| AMENDMENT A   |   | CLAIMS REMAINING AFTER AMENDMENT |       | HIGHEST NUMBER PREVIOUSLY PAID FOR | PRESENT EXTRA   | RATE(\$)                                   | ADDITIONAL FEE(\$) | RATE(\$)                      | ADDITIONAL FEE(\$) |  |
|   | Total<br><small>(37 CFR 1.16(i))</small>  | *                                | Minus | **                                 | =               | x  | =                  | OR                            | x                  |  |
|   | Independent<br><small>(37 CFR 1.16(h))</small>  | *                                | Minus | ***                                | =               | x  | =                  | OR                            | x                  |  |
|   | Application Size Fee <small>(37 CFR 1.16(s))</small>  |                                  |       |                                    |                 |  |                    |                               | OR                 |  |
|   | FIRST PRESENTATION OF MULTIPLE DEPENDENT CLAIM <small>(37 CFR 1.16(j))</small>  |                                  |       |                                    |                 |  |                    |                               | OR                 |  |
|   |   |                                  |       |                                    | TOTAL ADD'L FEE |  |                    | OR                            | TOTAL ADD'L FEE    |  |
| AMENDMENT B   |   | CLAIMS REMAINING AFTER AMENDMENT |       | HIGHEST NUMBER PREVIOUSLY PAID FOR | PRESENT EXTRA   | RATE(\$)                                   | ADDITIONAL FEE(\$) | RATE(\$)                      | ADDITIONAL FEE(\$) |  |
|   | Total<br><small>(37 CFR 1.16(i))</small>  | *                                | Minus | **                                 | =               | x  | =                  | OR                            | x                  |  |
|   | Independent<br><small>(37 CFR 1.16(h))</small>  | *                                | Minus | ***                                | =               | x  | =                  | OR                            | x                  |  |
|   | Application Size Fee <small>(37 CFR 1.16(s))</small>  |                                  |       |                                    |                 |  |                    |                               | OR                 |  |
|   | FIRST PRESENTATION OF MULTIPLE DEPENDENT CLAIM <small>(37 CFR 1.16(j))</small>  |                                  |       |                                    |                 |  |                    |                               | OR                 |  |
|   |   |                                  |       |                                    | TOTAL ADD'L FEE |  |                    | OR                            | TOTAL ADD'L FEE    |  |
| <p>* If the entry in column 1 is less than the entry in column 2, write "0" in column 3.</p> <p>** If the "Highest Number Previously Paid For" IN THIS SPACE is less than 20, enter "20".</p> <p>*** If the "Highest Number Previously Paid For" IN THIS SPACE is less than 3, enter "3".</p> <p>The "Highest Number Previously Paid For" (Total or Independent) is the highest found in the appropriate box in column 1.</p> |   |                                  |       |                                    |                 |  |                    |                               |                    |  |



UNITED STATES PATENT AND TRADEMARK OFFICE

UNITED STATES DEPARTMENT OF COMMERCE
United States Patent and Trademark Office
Address: COMMISSIONER FOR PATENTS
P.O. Box 1450
Alexandria, Virginia 22313-1450
www.uspto.gov

Table with 4 columns: APPLICATION NUMBER (16/788,498), FILING OR 371(C) DATE (02/12/2020), FIRST NAMED APPLICANT (Mark Jefferson Reed), ATTY. DOCKET NO./TITLE (TX1000-C12)

CONFIRMATION NO. 8054

INFORMAL NOTICE

59911
MITCH HARRIS, LLC - GENERAL
P.O. BOX 1269
ATHENS, GA 30603-1269



Date Mailed: 04/15/2020

INFORMATIONAL NOTICE TO APPLICANT

Applicant is notified that the above-identified application contains the deficiencies noted below. No period for reply is set forth in this notice for correction of these deficiencies. However, if a deficiency relates to the inventor's oath or declaration, the applicant must file an oath or declaration in compliance with 37 CFR 1.63, or a substitute statement in compliance with 37 CFR 1.64, executed by or with respect to each actual inventor no later than the expiration of the time period set in the "Notice of Allowability" to avoid abandonment. See 37 CFR 1.53(f).

The item(s) indicated below are also required and should be submitted with any reply to this notice to avoid further processing delays.

- A properly executed inventor's oath or declaration has not been received for the following inventor(s): Stephen Michael Palik

Questions about the contents of this notice and the requirements it sets forth should be directed to the Office of Data Management, Application Assistance Unit, at (571) 272-4000 or (571) 272-4200 or 1-888-786-0101.

/fasrat/

**DECLARATION (37 CFR 1.63) FOR UTILITY OR DESIGN APPLICATION USING AN APPLICATION DATA SHEET (37 CFR 1.76)**

|                     |   |
|---------------------|---|
| Title of Invention: | MACHINE FOR PROVIDING A DYNAMIC DATABASE OF GEOGRAPHIC LOCATION INFORMATION FOR A PLURALITY OF WIRELESS DEVICES AND PROCESS FOR MAKING SAME |
|---------------------|---|

As the below named inventor, I hereby declare that:

This declaration is directed to:

- The attached application, or
- United States application or PCT international application number 14/642,408 filed on 3/9/2015.

The above-identified application was made or authorized to be made by me.

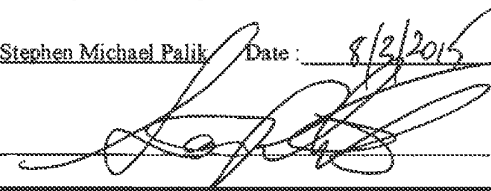
I believe that I am the original inventor or an original joint inventor of a claimed invention in the application.

I acknowledge the duty to disclose to the Patent and Trademark Office all information known to me to be material to patentability of the subject matter claimed in this application, as "materiality" is defined in 37 C.F.R. 1.56, which I understand includes information that is not cumulative to information already of record, or being made of record in the application, and that (1) establishes, by itself or in combination with other information, a prima facie case of unpatentability of a claim; or (2) refutes, or is inconsistent with, a position the applicant takes in: (i) opposing an argument of unpatentability relied on by the Patent Office, or (ii) asserting an argument of patentability.

I DECLARE THAT ALL STATEMENTS MADE OF MY OWN KNOWLEDGE ARE TRUE AND THAT ALL STATEMENTS MADE ON INFORMATION AND BELIEF ARE BELIEVED TO BE TRUE; AND FURTHER THAT THESE STATEMENTS WERE MADE WITH THE KNOWLEDGE THAT WILLFUL FALSE STATEMENTS AND THE LIKE SO MADE ARE PUNISHABLE BY FINE OR IMPRISONMENT, OR BOTH, UNDER SECTION 1001 OF TITLE 18 OF THE UNITED STATES CODE AND THAT SUCH WILLFUL FALSE STATEMENTS MAY JEOPARDIZE THE VALIDITY OF THE APPLICATION OR ANY PATENT ISSUED THEREON.

**LEGAL NAME OF INVENTOR**

Inventor: Stephen Michael Palik Date: 8/2/2015

Signature: 

Note: An application data sheet (PTO/SB/14 or equivalent), including naming the entire inventive entity, must accompany this form or must have been previously filed. Use an additional PTO/ALA/01 form for each additional inventor.

## Electronic Acknowledgement Receipt

|   |   |
|---|---|
| <b>EFS ID:</b>                              | 39202244  |
| <b>Application Number:</b>                  | 16788498  |
| <b>International Application Number:</b>    |   |
| <b>Confirmation Number:</b>                 | 8054  |
| <b>Title of Invention:</b>                  | MOBILE WIRELESS DEVICE PROVIDING OFF-LINE AND ON-LINE GEOGRAPHIC NAVIGATION INFORMATION |
| <b>First Named Inventor/Applicant Name:</b> | Mark Jefferson Reed   |
| <b>Customer Number:</b>                     | 59911   |
| <b>Filer:</b>                               | Andrew Mitchell Harris  |
| <b>Filer Authorized By:</b>                 |   |
| <b>Attorney Docket Number:</b>              | TX1000-C12  |
| <b>Receipt Date:</b>                        | 20-APR-2020   |
| <b>Filing Date:</b>                         | 12-FEB-2020   |
| <b>Time Stamp:</b>                          | 11:44:31  |
| <b>Application Type:</b>                    | Utility under 35 USC 111(a)   |

### Payment information:

|                        |    |
|------------------------|----|
| Submitted with Payment | no |
|------------------------|----|

### File Listing:

| Document Number | Document Description      | File Name                               | File Size(Bytes)/<br>Message Digest               | Multi Part /.zip | Pages (if appl.) |
|-----------------|---------------------------|---|---|------------------|------------------|
| 1               | Oath or Declaration filed | TX1000-C2_Declaration_Palick_signed.pdf | 27517<br>b5c9d488bacc25aef1b51ce63ca3d6ea236a9c67 | no               | 1                |

### Warnings:

The page size in the PDF is too large. The pages should be 8.5 x 11 or A4. If this PDF is submitted, the pages will be resized upon entry into the Image File Wrapper and may affect subsequent processing

**Information:**

|                                     |       |
|-------------------------------------|-------|
| <b>Total Files Size (in bytes):</b> | 27517 |
|-------------------------------------|-------|

**This Acknowledgement Receipt evidences receipt on the noted date by the USPTO of the indicated documents, characterized by the applicant, and including page counts, where applicable. It serves as evidence of receipt similar to a Post Card, as described in MPEP 503.**

**New Applications Under 35 U.S.C. 111**

**If a new application is being filed and the application includes the necessary components for a filing date (see 37 CFR 1.53(b)-(d) and MPEP 506), a Filing Receipt (37 CFR 1.54) will be issued in due course and the date shown on this Acknowledgement Receipt will establish the filing date of the application.**

**National Stage of an International Application under 35 U.S.C. 371**

**If a timely submission to enter the national stage of an international application is compliant with the conditions of 35 U.S.C. 371 and other applicable requirements a Form PCT/DO/EO/903 indicating acceptance of the application as a national stage submission under 35 U.S.C. 371 will be issued in addition to the Filing Receipt, in due course.**

**New International Application Filed with the USPTO as a Receiving Office**

**If a new international application is being filed and the international application includes the necessary components for an international filing date (see PCT Article 11 and MPEP 1810), a Notification of the International Application Number and of the International Filing Date (Form PCT/RO/105) will be issued in due course, subject to prescriptions concerning national security, and the date shown on this Acknowledgement Receipt will establish the international filing date of the application.**



UNITED STATES PATENT AND TRADEMARK OFFICE

UNITED STATES DEPARTMENT OF COMMERCE
United States Patent and Trademark Office
Address: COMMISSIONER FOR PATENTS
P.O. Box 1450
Alexandria, Virginia 22313-1450
www.uspto.gov

Table with 5 columns: APPLICATION NO., FILING DATE, FIRST NAMED INVENTOR, ATTORNEY DOCKET NO., CONFIRMATION NO.
Row 1: 16/788,498, 02/12/2020, Mark Jefferson Reed, TX1000-C12, 8054
Row 2: 59911, 7590, 04/28/2020, MITCH HARRIS, LLC - GENERAL, P.O. BOX 1269, ATHENS, GA 30603-1269
Row 3: EXAMINER, NGO, RICKY QUOC
Row 4: ART UNIT, PAPER NUMBER, 2464
Row 5: MAIL DATE, DELIVERY MODE, 04/28/2020, PAPER

Please find below and/or attached an Office communication concerning this application or proceeding.

The time period for reply, if any, is set in the attached communication.

|  |                                      |                                    |                                |
|--|--------------------------------------|------------------------------------|--------------------------------|
| <b><i>Decision Granting Request for<br/>Prioritized Examination (Track I)</i></b>  | <b>Application No.</b><br>16/788,498 | <b>Applicant(s)</b><br>Reed et al. |                                |
|  | <b>Examiner</b><br>APRIL M WISE      | <b>Art Unit</b><br>OPET            | <b>AIA (FITF) Status</b><br>No |
| <p>1. THE REQUEST FILED <u>12 February 2020</u> IS <b>GRANTED</b> .</p> <p>The above-identified application has met the requirements for prioritized examination</p> <p>A. <input checked="" type="checkbox"/> for an original nonprovisional application (Track I).</p> <p>B. <input type="checkbox"/> for an application undergoing continued examination (RCE).</p> <p>2. <b>The above-identified application will undergo prioritized examination.</b> The application will be accorded special status throughout its entire course of prosecution until one of the following occurs:</p> <p>A. filing a <b><u>petition for extension of time</u></b> to extend the time period for filing a reply;</p> <p>B. filing an <b><u>amendment to amend the application to contain more than four independent claims, more than thirty total claims</u></b>, or a multiple dependent claim;</p> <p>C. filing a <b><u>request for continued examination</u></b> ;</p> <p>D. filing a notice of appeal;</p> <p>E. filing a request for suspension of action;</p> <p>F. mailing of a notice of allowance;</p> <p>G. mailing of a final Office action;</p> <p>H. completion of examination as defined in 37 CFR 41.102; or</p> <p>I. abandonment of the application.</p> <p>Telephone inquiries with regard to this decision should be directed to undersigned at (571)272-1642.<br/>In his/her absence, calls may be directed to Petition Help Desk at (571) 272-3282.</p> |                                      |                                    |                                |
| /APRIL M WISE/<br>Paralegal Specialist, Office of Petitions  |                                      |                                    |                                |

|  |   |   |
|--|---|---|
| <b>Doc Code: DIST.E.FILE</b><br><b>Document Description: Electronic Terminal Disclaimer - Filed</b>  |   | PTO/SB/26<br>U.S. Patent and Trademark Office<br>Department of Commerce |
| Electronic Petition Request  | <b>TERMINAL DISCLAIMER TO OBTAIN A DOUBLE PATENTING REJECTION OVER A "PRIOR" PATENT</b> |   |
| Application Number   | 16788498  |   |
| Filing Date  | 12-Feb-2020   |   |
| First Named Inventor   | Mark Reed   |   |
| Attorney Docket Number   | TX1000-C12  |   |
| Title of Invention   | MOBILE WIRELESS DEVICE PROVIDING OFF-LINE AND ON-LINE GEOGRAPHIC NAVIGATION INFORMATION |   |
| <input checked="" type="checkbox"/> Filing of terminal disclaimer does not obviate requirement for response under 37 CFR 1.111 to outstanding Office Action<br><br><input checked="" type="checkbox"/> This electronic Terminal Disclaimer is not being used for a Joint Research Agreement.   |   |   |
| Owner  | Percent Interest  |   |
| Traxcell Technologies, LLC   | 100%  |   |
| <p>The owner(s) with percent interest listed above in the instant application hereby disclaims, except as provided below, the terminal part of the statutory term of any patent granted on the instant application which would extend beyond the expiration date of the full statutory term of prior patent number(s)</p> <p>9549388</p> <p>as the term of said prior patent is presently shortened by any terminal disclaimer. The owner hereby agrees that any patent so granted on the instant application shall be enforceable only for and during such period that it and the prior patent are commonly owned. This agreement runs with any patent granted on the instant application and is binding upon the grantee, its successors or assigns.</p> <p>In making the above disclaimer, the owner does not disclaim the terminal part of the term of any patent granted on the instant application that would extend to the expiration date of the full statutory term of the prior patent, "as the term of said prior patent is presently shortened by any terminal disclaimer," in the event that said prior patent later:</p> <ul style="list-style-type: none"> <li>- expires for failure to pay a maintenance fee;</li> <li>- is held unenforceable;</li> <li>- is found invalid by a court of competent jurisdiction;</li> <li>- is statutorily disclaimed in whole or terminally disclaimed under 37 CFR 1.321;</li> <li>- has all claims canceled by a reexamination certificate;</li> <li>- is reissued; or</li> <li>- is in any manner terminated prior to the expiration of its full statutory term as presently shortened by any terminal disclaimer.</li> </ul> <p><input checked="" type="radio"/> Terminal disclaimer fee under 37 CFR 1.20(d) is included with Electronic Terminal Disclaimer request.</p> |   |   |



|   |                                  |
|---|----------------------------------|
| <input type="radio"/> I certify, in accordance with 37 CFR 1.4(d)(4), that the terminal disclaimer fee under 37 CFR 1.20(d) required for this terminal disclaimer has already been paid in the above-identified application.  |                                  |
| Applicant claims the following fee status:  |                                  |
| <input checked="" type="radio"/> Small Entity<br><input type="radio"/> Micro Entity<br><input type="radio"/> Regular Undiscounted   |                                  |
| I hereby declare that all statements made herein of my own knowledge are true and that all statements made on information and belief are believed to be true; and further that these statements were made with the knowledge that willful false statements and the like so made are punishable by fine or imprisonment, or both, under Section 1001 of Title 18 of the United States Code and that such willful false statements may jeopardize the validity of the application or any patent issued thereon. |                                  |
| THIS PORTION MUST BE COMPLETED BY THE SIGNATORY OR SIGNATORIES  |                                  |
| I certify, in accordance with 37 CFR 1.4(d)(4) that I am:   |                                  |
| <input checked="" type="radio"/> An attorney or agent registered to practice before the Patent and Trademark Office who is of record in this application<br><br>Registration Number <u>  42638  </u>  |                                  |
| <input type="radio"/> A sole inventor   |                                  |
| <input type="radio"/> A joint inventor; I certify that I am authorized to sign this submission on behalf of all of the inventors as evidenced by the power of attorney in the application   |                                  |
| <input type="radio"/> A joint inventor; all of whom are signing this request  |                                  |
| Signature   | /Andrew Mitchell Harris #42,638/ |
| Name  | Andrew Mitchell Harris           |

\*Statement under 37 CFR 3.73(b) is required if terminal disclaimer is signed by the assignee (owner).  
 Form PTO/SB/96 may be used for making this certification. See MPEP § 324.

## Electronic Patent Application Fee Transmittal

|  |   |                 |               |                             |
|--|---|-----------------|---------------|-----------------------------|
| <b>Application Number:</b>                         | 16788498  |                 |               |                             |
| <b>Filing Date:</b>                                | 12-Feb-2020   |                 |               |                             |
| <b>Title of Invention:</b>                         | MOBILE WIRELESS DEVICE PROVIDING OFF-LINE AND ON-LINE GEOGRAPHIC NAVIGATION INFORMATION |                 |               |                             |
| <b>First Named Inventor/Applicant Name:</b>        | Mark Jefferson Reed   |                 |               |                             |
| <b>Filer:</b>                                      | Andrew Mitchell Harris  |                 |               |                             |
| <b>Attorney Docket Number:</b>                     | TX1000-C12  |                 |               |                             |
| Filed as Small Entity                              |   |                 |               |                             |
| <b>Filing Fees for Utility under 35 USC 111(a)</b> |   |                 |               |                             |
| <b>Description</b>                                 | <b>Fee Code</b>   | <b>Quantity</b> | <b>Amount</b> | <b>Sub-Total in USD(\$)</b> |
| <b>Basic Filing:</b>                               |   |                 |               |                             |
| STATUTORY OR TERMINAL DISCLAIMER                   | 2814  | 1               | 160           | 160                         |
| <b>Pages:</b>                                      |   |                 |               |                             |
| <b>Claims:</b>                                     |   |                 |               |                             |
| <b>Miscellaneous-Filing:</b>                       |   |                 |               |                             |
| <b>Petition:</b>                                   |   |                 |               |                             |
| <b>Patent-Appeals-and-Interference:</b>            |   |                 |               |                             |
| <b>Post-Allowance-and-Post-Issuance:</b>           |   |                 |               |                             |

| <b>Description</b>        | <b>Fee Code</b> | <b>Quantity</b> | <b>Amount</b> | <b>Sub-Total in USD(\$)</b> |
|---------------------------|-----------------|-----------------|---------------|-----------------------------|
| <b>Extension-of-Time:</b> |                 |                 |               |                             |
| <b>Miscellaneous:</b>     |                 |                 |               |                             |
| <b>Total in USD (\$)</b>  |                 |                 |               | <b>160</b>                  |

Doc Code: DISQ.E.FILE  
Document Description: Electronic Terminal Disclaimer – Approved

Application No.: 16788498

Filing Date: 12-Feb-2020

Applicant/Patent under Reexamination: Reed

Electronic Terminal Disclaimer filed on May 19, 2020

APPROVED

**This patent is subject to a terminal disclaimer**

DISAPPROVED

Approved/Disapproved by: Electronic Terminal Disclaimer automatically approved by EFS-Web

U.S. Patent and Trademark Office

## Electronic Acknowledgement Receipt

|   |   |
|---|---|
| <b>EFS ID:</b>                              | 39478577  |
| <b>Application Number:</b>                  | 16788498  |
| <b>International Application Number:</b>    |   |
| <b>Confirmation Number:</b>                 | 8054  |
| <b>Title of Invention:</b>                  | MOBILE WIRELESS DEVICE PROVIDING OFF-LINE AND ON-LINE GEOGRAPHIC NAVIGATION INFORMATION |
| <b>First Named Inventor/Applicant Name:</b> | Mark Jefferson Reed   |
| <b>Customer Number:</b>                     | 59911   |
| <b>Filer:</b>                               | Andrew Mitchell Harris  |
| <b>Filer Authorized By:</b>                 |   |
| <b>Attorney Docket Number:</b>              | TX1000-C12  |
| <b>Receipt Date:</b>                        | 19-MAY-2020   |
| <b>Filing Date:</b>                         | 12-FEB-2020   |
| <b>Time Stamp:</b>                          | 12:51:39  |
| <b>Application Type:</b>                    | Utility under 35 USC 111(a)   |

### Payment information:

|  |                  |
|--|------------------|
| Submitted with Payment                   | yes              |
| Payment Type                             | CARD             |
| Payment was successfully received in RAM | \$160            |
| RAM confirmation Number                  | E20205IC51355088 |
| Deposit Account                          |                  |
| Authorized User                          |                  |

The Director of the USPTO is hereby authorized to charge indicated fees and credit any overpayment as follows:

| <b>File Listing:</b>  |  |                          |  |                         |                         |
|---|--|--------------------------|--|-------------------------|-------------------------|
| <b>Document Number</b>  | <b>Document Description</b>            | <b>File Name</b>         | <b>File Size(Bytes)/ Message Digest</b>  | <b>Multi Part /.zip</b> | <b>Pages (if appl.)</b> |
| 1   | Terminal Disclaimer-Filed (Electronic) | eTerminal-Disclaimer.pdf | 33722                                    | no                      | 2                       |
|   |  |                          | d1282fc50d0de76141a1ced3d3a1689fd9f3f85  |                         |                         |
| <b>Warnings:</b>  |  |                          |  |                         |                         |
| <b>Information:</b>   |  |                          |  |                         |                         |
| 2   | Fee Worksheet (SB06)                   | fee-info.pdf             | 30710                                    | no                      | 2                       |
|   |  |                          | 815eee9523edf23fd411fd1911a8cddc5943cdf8 |                         |                         |
| <b>Warnings:</b>  |  |                          |  |                         |                         |
| <b>Information:</b>   |  |                          |  |                         |                         |
| <b>Total Files Size (in bytes):</b>   |  |                          | 64432                                    |                         |                         |
| <p><b>This Acknowledgement Receipt evidences receipt on the noted date by the USPTO of the indicated documents, characterized by the applicant, and including page counts, where applicable. It serves as evidence of receipt similar to a Post Card, as described in MPEP 503.</b></p> <p><b><u>New Applications Under 35 U.S.C. 111</u></b><br/> <b>If a new application is being filed and the application includes the necessary components for a filing date (see 37 CFR 1.53(b)-(d) and MPEP 506), a Filing Receipt (37 CFR 1.54) will be issued in due course and the date shown on this Acknowledgement Receipt will establish the filing date of the application.</b></p> <p><b><u>National Stage of an International Application under 35 U.S.C. 371</u></b><br/> <b>If a timely submission to enter the national stage of an international application is compliant with the conditions of 35 U.S.C. 371 and other applicable requirements a Form PCT/DO/EO/903 indicating acceptance of the application as a national stage submission under 35 U.S.C. 371 will be issued in addition to the Filing Receipt, in due course.</b></p> <p><b><u>New International Application Filed with the USPTO as a Receiving Office</u></b><br/> <b>If a new international application is being filed and the international application includes the necessary components for an international filing date (see PCT Article 11 and MPEP 1810), a Notification of the International Application Number and of the International Filing Date (Form PCT/RO/105) will be issued in due course, subject to prescriptions concerning national security, and the date shown on this Acknowledgement Receipt will establish the international filing date of the application.</b></p> |  |                          |  |                         |                         |

**From:** mitch@harrispatent.com  
**To:** Patel, Ajit  
**Subject:** 16/788,498 Examiner's Amendment  
**Date:** Monday, May 18, 2020 6:58:18 PM  
**Attachments:** EX1000-C12\_ProposedExaminerAmendment\_05-18-20.docx

---

Dear Examiner Patel,

Attached is a document with claims language for a proposed examiner's amendment in the above-captioned application

Best Regards,

Mitch Harris  
U.S. Registered Patent Attorney  
Mitch Harris, Atty at Law, L.L.C.  
P.O. Box 1269 Athens, GA 30603-1269  
866-553-4918 (voice or fax)  
847-461-1595 (International voice/fax)

---

This e-mail is intended solely for the person or entity to which it is addressed and may contain confidential and/or privileged information. Any review, dissemination, copying, printing or other use of this e-mail by persons or entities other than the addressee is prohibited. If you have received this e-mail in error, please contact the sender immediately and delete the material from any computer.

-----Original Message-----

From: mitch@harrispatent.com <mitch@harrispatent.com>  
Sent: Wednesday, May 13, 2020 12:12 PM  
To: 'ajit.patel@uspto.gov' <ajit.patel@uspto.gov>  
Subject: 16/788,498 Examiner Interview

Dear Examiner Patel,

I received your voice mail. Thank you. 11AM tomorrow is fine.

Best Regards,

Mitch Harris  
U.S. Registered Patent Attorney

Mitch Harris, Atty at Law, L.L.C.  
P.O. Box 1269 Athens, GA 30603-1269  
866-553-4918 (voice or fax)  
847-461-1595 (International voice/fax)

---

—

This e-mail is intended solely for the person or entity to which it is addressed and may contain confidential and/or privileged information. Any review, dissemination, copying, printing or other use of this e-mail by persons or entities other than the addressee is prohibited. If you have received this e-mail in error, please contact the sender immediately and delete the material from any computer. Please be aware that no attorney-client relationship has been established with me or any member of our firm absent a written engagement letter, or upon payment of a fee provided for retention of our services. Any legal advice or confidential information provided herein is provided only for the use of the intended recipient(s) and should not be relied upon by any other party or disseminated.



IN THE UNITED STATES PATENT AND TRADEMARK OFFICE

|  |                          |
|--|--------------------------|
| Applicant(s):<br>Reed  |                          |
| Application No.: 16/788,498  | Art Unit:<br>2416        |
| Filed: 02/12/2020  | Examiner:<br>Patel, Ajit |
| Title: MOBILE WIRELESS DEVICE PROVIDING<br>OFF-LINE AND ON-LINE GEOGRAPHIC<br>NAVIGATION INFORMATION |                          |
| Attorney Docket No.: TX1000-C12  |                          |

VIA E-MAIL to:

Examiner Patel

**PROPOSED EXAMINER'S AMENDMENT**

Dear Examiner Patel:

In conjunction with your telephone call of 05/14/2020 proposing an Examiner's Amendment, Applicant submits the following proposed Claims for an Examiner's Amendment in conformity with your request and authorizes entry thereof if the amendment places the Application in condition for Allowance.

## IN THE CLAIMS

Please amend the claims in accordance with the following mark-up copy:

1. (Original) A wireless communications system including:

a first radio-frequency transceiver within a wireless mobile communications device and an associated first antenna to which the first radio-frequency transceiver is coupled, wherein the first radio-frequency transceiver is configured for radio-frequency communication with a wireless communications network;

a first processor within the wireless mobile communications device coupled to the at least one first radio-frequency transceiver programmed to receive information indicative of a location of the wireless mobile communications device ~~from the wireless communications network~~ and generate an indication of a location of the wireless mobile communications device with respect to geographic features according to mapping information stored within the wireless mobile communications device, and wherein the first processor determines user navigation information and displays to the user navigation information according to the location of the wireless mobile communications device with respect to the geographic features and a destination specified by the user at the wireless mobile communications device, wherein the first processor further sends the user navigation information to the network as a number of segments, wherein at least one other processor outside the network updates the user navigation information in conformity with traffic congestion information accessible to the at least one other processor outside the network by computing a numerical value for the segments corresponding to the expected time to travel through the segments, updates the user navigation information in

conformity with the numerical values for the segments, and sends the updated user navigation information to the wireless mobile communications device;

at least one second radio-frequency transceiver and an associated at least one second antenna of the wireless communications network to which the second radio-frequency transceiver is coupled; and

a second processor coupled to the at least one second radio-frequency transceiver programmed to acquire the information indicative of a location of the wireless mobile communications device, wherein the second processor selectively acquires the information indicative of a location of the wireless mobile communications device dependent on the setting of preference flags, wherein the second processor acquires the information indicative of a location of the wireless mobile communications device if the preference flags are set to a state that permits tracking of the user of the wireless mobile communications device, and wherein the second processor does not acquire the information indicative of the location of the wireless mobile communications device if the preference flags are set to a state that prohibits tracking of the wireless mobile communications device.

2. (Canceled)

3. (Currently Amended) The wireless communications system of Claim 1, wherein the first processor is further programmed to:

determine whether or not the mapping information stored within the wireless mobile communications device is sufficient to display the navigation information ~~to the user~~;

responsive to the first processor determining that the mapping information is sufficient, the processor displaying the navigation information ~~to the user~~;

responsive to the first processor determining that the mapping information is not sufficient, the first processor requesting additional mapping information from at least one other processor outside the wireless communications network; and

responsive to the first processor requesting additional mapping information from at least one other processor outside the wireless communications network, the first processor receiving the additional mapping information from the at least one other processor outside the wireless communications network and the first processor displaying the navigation information ~~to the user~~ using the additional mapping information.

4. (Original) The wireless communications system of Claim 3, wherein the first processor further updates the mapping information stored within the wireless mobile communications device with the additional information received from the wireless communications network.

5. (Currently Amended) The wireless communications system of Claim 4, wherein the first processor, responsive to not receiving the additional mapping information from the wireless communications network, ~~displaying~~ displays a notice ~~to the user~~ that the destination could not be found.

6. (Original) The wireless communications system of Claim 2, wherein the first processor further requests from the wireless communications network, traffic congestion information, wherein the first processor receives the requested traffic congestion information and determines the user navigation information in conformity with the received traffic congestion information.

Claims 7-8 are canceled.

9. (Currently Amended) The wireless communications system of Claim ~~1~~<sup>7</sup>, wherein the another processor determines whether or not the updated user navigation information already exists in the wireless mobile communications device, and does not transmit the updated user navigation information to the wireless mobile communications device if the updated user navigation information already exists in the wireless mobile communications device.

10. (Original) The wireless communications system of Claim 1, wherein the first processor further sends the indication of a location of the wireless mobile communications device with respect to the geographic features to the network, wherein at least one other processor outside the network receives the indication of a location of the wireless mobile communications device, determines the user navigation information in conformity with the location of the wireless mobile communications device and transmits the user navigation information to the wireless mobile communications device.

11. (Original) The wireless communications system of Claim 1, wherein the preference flags are specified by ~~the user of~~ the wireless mobile communications device and transmitted to the at least one second radio-frequency transceiver.

12. (Original) The wireless communications system of Claim 1, wherein the preference flags have more than two states including at least: a first state that prohibits tracking of the mobile wireless communications device, a second state that permits open access to the location of the wireless mobile communications device and information associated with the wireless mobile communications device, and a third state that provides access to the information indicative of the location of the wireless mobile communications device but not information associated with the wireless mobile communications device other than a generic identifier, and wherein the second processor provides information about ~~the a~~ user of the wireless mobile communications device to at least one other processor outside the network in conformity with permissions specified by the preference flags.

13. (Currently Amended) The wireless communications system of Claim 12, wherein the preference flags have more than three states, including at least a fourth state that provides access to the location of the wireless mobile communications device and demographic information associated with the wireless mobile communications device, but not a name of the user associated with the wireless mobile communications device or other private information.

14. (Currently Amended) A method of providing navigation information within a wireless communications network, the method comprising:

at a wireless mobile communications device coupled to the wireless communications network and having a first radio-frequency transceiver coupled to an associated first antenna, receiving information indicative of a location of the mobile wireless communications device;

within the wireless mobile communications device, a first processor within the wireless mobile communications device coupled to the first radio-frequency transceiver generating an indication of a location of the at least one wireless mobile communications device with respect to geographic features according to mapping information retrieved from a storage within the wireless mobile communications device;

the first processor determining user navigation information;

sending the user navigation information to the at least one other processor outside the network as a number of segments;

at a remote location within the at least one other processor outside the network, updating the user navigation information in conformity with traffic congestion information accessible to the remote location within the network by computing a numerical value for the segments corresponding to the expected time to travel through the segments, and wherein the updating is performed in conformity with the numerical values for the number of segments;

sending the updated user navigation information to the wireless mobile communications device;

the first processor displaying ~~to the user~~ the user navigation information according to the location of the wireless mobile communications device with respect to the geographic features and a destination specified by ~~the user at~~ the wireless mobile communications device;

within the wireless communications network, a second processor coupled to at least one second radio-frequency transceiver coupled to an associated second antenna selectively acquiring the information indicative of a location of the wireless mobile communication device in dependence on a setting of preference flags, wherein the selectively acquiring the information indicative of a location of the wireless mobile communications device if the preference flags are set to a state that permits tracking of the user of the wireless mobile communications device, and wherein the selectively determining does not acquire the information indicative of a location of the wireless mobile communications device if the preference flags are set to a state that prohibits tracking of the wireless mobile communications device.

15. (Original) The method of Claim 14, further comprising within the wireless mobile communications device, determining the user navigation information.

16. (Currently Amended) The method of Claim 15, further comprising:

within the wireless mobile communications device, determining whether or not the mapping information stored within the wireless mobile communications device is sufficient to display the navigation information ~~to the user~~;



responsive to determining that the mapping information is sufficient, displaying the navigation information ~~to the user~~;

responsive to determining that the mapping information is not sufficient, requesting additional mapping information from at least one other processor outside the wireless communications network; and

responsive to the requesting additional mapping information from the at least one other processor outside the wireless communications network, receiving the additional mapping information from the at least one other processor outside the wireless communications network and displaying the navigation information ~~to the user~~ using the additional mapping information.

17. (Original) The method of Claim 16, further comprising updating the mapping information stored within the wireless mobile communications device with the additional information received from the at least one other processor outside the wireless communications network.

18. (Currently Amended) The method of Claim 16, further comprising responsive to not receiving the additional mapping information from the at least one other processor outside the wireless communications network, displaying a notice ~~to the user~~ that the destination could not be found.

19. (Canceled)

20. (Original) The method of Claim 19, further comprising, at the remote location, determining whether or not the updated user navigation information already exists in the wireless mobile communications device, and wherein the transmitting of the updated user navigation information is not performed if the updated user navigation information already exists in the wireless mobile communications device.

21. (Original) The method of Claim 14, further comprising:

requesting from the at least one other processor outside the wireless communications network, traffic congestion information;

receiving the requested traffic congestion information at the mobile wireless communications device; and

determining the user navigation information in conformity with the received traffic congestion information.

22. (Canceled)

23. (Original) The method of Claim 14, further comprising:

at the wireless mobile communications device, sending the location of the wireless mobile communications device with respect to the geographic features to at least one other processor outside the network;

receiving the location of the wireless mobile communications device at the at least one other processor outside the network; and

at a remote at least one other processor outside the network, determining the user navigation information in conformity with the location of the wireless mobile communications device; and

transmitting the user navigation information to the wireless mobile communications device.

24. (Currently Amended) The method of Claim 14, wherein the preference flags are specified by ~~the~~ a user associated with ~~of~~ the wireless mobile communications device, and wherein the method further comprises transmitting the preference flags to the at least one second radio-frequency transceiver.

25. (Currently Amended) The method of Claim 14, wherein the preference flags have more than two states including at least: a first state that prohibits tracking of the mobile wireless communications device, a second state that permits open access to the location of the wireless mobile communications device and information associated with the wireless mobile communications device, and a third state that provides access to the location of the wireless mobile communications device but not information associated with the wireless mobile communications device other than a generic identifier, and wherein method further comprises the second processor providing information about ~~a the user of~~ associated with the wireless mobile

communications device to at least one other processor outside the wireless network in conformity with permissions specified by the preference flags.

26. (Original) The method of Claim 25, wherein the preference flags have more than three states, including at least a fourth state that provides access to the location of the wireless mobile communications device and demographic information associated with the wireless mobile communications device, but not a name of the user associated with the wireless mobile communications device or other private information.

27. (Currently Amended) A wireless mobile communications device including:

a radio-frequency transceiver and an associated antenna to which the radio-frequency transceiver is coupled, wherein the radio-frequency transceiver is configured for radio-frequency communication with a wireless communications network; and

a first processor coupled to the at least one radio-frequency transceiver programmed to receive a location of the wireless mobile communications device and generate an indication of a location of the at least one wireless mobile communications device with respect to geographic features according to mapping information stored within the wireless mobile communications device, wherein the first processor determines whether or not the mapping information stored within the wireless mobile communications device is sufficient to display the navigation information to the user, responsive to the first processor determining that the mapping information is not sufficient, the first processor requesting additional mapping information from at least one other processor outside the wireless communications network and responsive to the

first processor requesting additional mapping information from the at least one other processor outside the wireless communications network, receiving the additional mapping information from the at least one other processor outside the wireless communications network and updating the mapping information stored within the wireless mobile communications device, wherein the first processor determines and displays the navigation information to the user using the additional mapping information, the location of the wireless mobile communications device with respect to the geographic features and a destination specified by the user at the wireless mobile communications device, and wherein the first processor communicates to the mobile communications network a setting of preference flags, wherein the first processor further sends the user navigation information to the at least one other processor outside of the network, wherein the at least one other processor outside of the network updates the user navigation information in conformity with traffic congestion information accessible to the other processor coupled to the network and transmits the updated user navigation information to the mobile device, wherein the first processor further sends the user navigation information to the at least one other processor outside of the network as a number of segments, and wherein the at least one other processor outside of the network computes a numerical value for each segment corresponding to the expected time to travel through the segment and wherein the user navigation information is updated in conformity with the numerical values for the number of segments, wherein ~~whereby~~ the mobile communications network selectively acquires information indicative of a location of the mobile communications device and communicates the information indicative of a location of the wireless mobile communications device to the wireless mobile communications device dependent on the setting of the preference flags, wherein if the preference flags are set to a state that permits tracking of the user of the wireless mobile

communications device the at least one other processor outside the wireless communications network receives the location of the wireless mobile communications device, and wherein if the preference flags are set to a state that prohibits tracking of the wireless mobile communications device, the at least one other processor outside the wireless communications network does not receive the location of the wireless mobile communications device.

28. (Canceled)

29. (Currently Amended) The wireless mobile communications device of Claim 27 ~~28~~, wherein the another processor determines whether or not the updated user navigation information already exists in the wireless mobile communications device, and does not transmit the updated user navigation information to the mobile device if the updated user navigation information already exists in the wireless mobile communications device.

30. (Original) The wireless mobile communications device of Claim 27, wherein the preference flags have more than two states including at least: a first state that prohibits tracking of the mobile wireless communications device, a second state that permits open access to the location of the wireless mobile communications device and information associated with the wireless mobile communications device, and a third state that provides access to the location of the wireless mobile communications device but not information associated with the wireless mobile communications device other than a generic identifier, whereby the wireless communications network processor provides information about the user of the wireless mobile communications device in conformity with permissions specified by the preference flags.

Under the Paperwork Reduction Act of 1995, no persons are required to respond to a collection of information unless it displays a valid OMB control number.

|  |                                       |
|--|---------------------------------------|
| Substitute for form 1449/PTO<br><br><b>INFORMATION DISCLOSURE<br/>STATEMENT BY APPLICANT</b> | <b>Complete if Known</b>              |
|  | Application Number <b>16/788,498</b>  |
|  | Filing Date            2/12/2020      |
|  | First Named Inventor    Reed          |
|  | Examiner Name         -- Unknown --   |
|  | Art Unit                -- Unknown -- |
|  | Attorney Docket No.    TX1000-C12     |

| Examiner Initials | Document Number   | Publication Date<br>MM-DD-YYYY | Name of Patentee or<br>Applicant of Cited Document | Pages, Columns, Lines, Where<br>Relevant Passages or Relevant<br>Figures Appear |
|-------------------|-------------------|--------------------------------|--|---|
|                   | US-10,390,175-B2  | 08-20-2019                     | Reed, et al.                                       |   |
|                   | US-9,888,353-B2   | 02-06-2018                     | Reed, et al.                                       |   |
|                   | US-9,642,024-B2   | 05-02-2017                     | Reed, et al.                                       |   |
|                   | US-9,549,388-B2   | 01-17-2017                     | Reed, et al.                                       |   |
|                   | US-9,510,320-B2   | 11-29-2016                     | Reed, et al.                                       |   |
|                   | US-8,977,284-B2   | 03-10-2015                     | Reed   |   |
|                   | US-20030134648-A1 | 07-17-2003                     | Reed   |   |
|                   | US-9,918,196-B2   | 03-13-2018                     | Reed, et al.                                       |   |
|                   | US-10,448,209     | 10-15-2019                     | Reed, et al.                                       |   |
|                   | US-20200015039-A1 | 01-09-2020                     | Reed, et al.                                       |   |
|                   | US-16/779,590     | 02-01-2020                     | Reed, et al.                                       |   |
|                   | US-6,931,256-B2   | 08-16-2005                     | Mandyam  |   |
|                   | US-6,334,047-B1   | 12-25-2001                     | Andersson, et al.                                  |   |
|                   | US-7,689,240-B2   | 03-30-2010                     | Anderson   |   |
|                   | US-7,120,392-B2   | 10-10-2006                     | Chu, et al.  |   |
|                   | US-6,157,838      | 12-05-2000                     | Di Huo, et al.                                     |   |
|                   | US-7,574,230-B1   | 08-11-2009                     | Oh, et al.   |   |
|                   | US-6,298,306-B1   | 10-02-2001                     | Suarez, et al.                                     |   |
|                   | US-7,634,266-B2   | 12-15-2009                     | McDougall, et al.                                  |   |
|                   | US-6,751,443-B2   | 06-15-2004                     | Haymes, et al.                                     |   |
|                   | US-7,333,820-B2   | 02-19-2008                     | Sheha, et al.                                      |   |
|                   | US-8,218,507-B2   | 07-10-2012                     | Palmer, et al.                                     |   |
|                   | US-7,853,267-B2   | 12-14-2010                     | Jensen   |   |
|                   | US-6,901,264      | 05-31-2005                     | Myr  |   |
|                   | US-3,419,865      | 12-31-1968                     | Chisholm   |   |
|                   | US-4,494,119      | 01-15-1985                     | Wimbush  |   |
|                   | US-5,873,040      | 02-16-1999                     | Dunn, et al.                                       |   |
|                   | US-5,930,515      | 07-27-1999                     | Ducharme, et al.                                   |   |
|                   | US-6,308,073-B1   | 10-23-2001                     | Petty, et al.                                      |   |
|                   | US-7,366,522-B2   | 04-29-2008                     | Thomas   |   |
|                   | US-6,799,049-B1   | 09-28-2004                     | Zellner, et al.                                    |   |

Examiner: /AJIT PATEL/

Date Considered: 05/18/2020

EXAMINER: Initial if reference considered, whether or not citation is in conformance with MPEP 609; Draw line through citation if not in conformance and not considered. Include copy of this form with next communication to applicant.

ALL REFERENCES CONSIDERED EXCEPT WHERE LINED THROUGH. /A.P/



|  |                          |               |
|--|--------------------------|---------------|
| Substitute for form 1449/PTO<br><br><b>INFORMATION DISCLOSURE<br/>STATEMENT BY APPLICANT</b> | <b>Complete if Known</b> |               |
|  | Application Number       | 16/788,498    |
|  | Filing Date              | 2/12/2020     |
|  | First Named Inventor     | Reed          |
|  | Examiner Name            | -- Unknown -- |
|  | Art Unit                 | -- Unknown -- |
|  | Attorney Docket No.      | TX1000-C12    |

| Examiner Initials | Document Number   | Publication Date<br>MM-DD-YYYY | Name of Patentee or<br>Applicant of Cited Document | Pages, Columns, Lines, Where<br>Relevant Passages or Relevant<br>Figures Appear |
|-------------------|-------------------|--------------------------------|--|---|
|                   | US-4,908,629      | 03-13-1990                     | Apsell, et al.                                     |   |
|                   | US-4,891,650      | 01-02-1990                     | Sheffer  |   |
|                   | US-6,249,252-B1   | 06-19-2001                     | Dupray   |   |
|                   | US-6,249,680-B1   | 06-19-2001                     | Wax, et al.  |   |
|                   | US-6,167,275      | 12-26-2000                     | Oros, et al.                                       |   |
|                   | US-6,091,956      | 07-18-2000                     | Hollenberg   |   |
|                   | US-6,633,761-B1   | 10-14-2003                     | Singhal, et al.                                    |   |
|                   | US-5,561,704      | 10-01-1996                     | Salimando  |   |
|                   | US-5,694,335      | 12-02-1997                     | Hollenberg   |   |
|                   | US-6,150,961      | 11-21-2000                     | Alewine, et al.                                    |   |
|                   | US-20150309295-A1 | 10-29-2015                     | Cocker, et al.                                     |   |
|                   | US-7,082,365-B2   | 07-25-2006                     | Sheha, et al.                                      |   |
|                   | US-20020052786-A1 | 05-02-2002                     | Kim, et al.  |   |
|                   | US-5,933,100      | 08-03-1999                     | Golding  |   |
|                   | US-6,052,598      | 04-18-2000                     | Rudrapatna, et al.                                 |   |
|                   | US-6,362,783-B1   | 03-26-2002                     | Sigiura, et al.                                    |   |
|                   | US-6,505,114-B2   | 01-07-2003                     | Luciani  |   |
|                   | US-6,314,365-B1   | 11-06-2001                     | Smith  |   |
|                   | US-6,490,521-B2   | 12-03-2002                     | Wiener   |   |
|                   | US-6,401,035-B2   | 06-04-2002                     | Jin  |   |
|                   | US-6,654,683-B2   | 11-25-2003                     | Jin, et al.  |   |
|                   | US-7,389,179-B2   | 06-17-2008                     | Jin, et al.  |   |
|                   | US-6,151,505      | 11-21-2000                     | Larkins, et al.                                    |   |
|                   | US-6,292,743-B1   | 09-18-2001                     | Pu, et al.   |   |
|                   | US-6,111,539      | 08-29-2000                     | Mannings, et al.                                   |   |
|                   | US-5,504,482      | 04-02-1996                     | Schreder   |   |
|                   | US-5,712,899      | 01-27-1998                     | Pace, II   |   |
|                   | US-6,295,502-B1   | 09-25-2001                     | Hancock, et al.                                    |   |
|                   | US-6,542,816-B1   | 04-01-2003                     | Ito, et al.  |   |
|                   | US-5,959,577      | 09-28-1999                     | Fan, et al.  |   |
|                   | US-6,088,594      | 07-11-2000                     | Kingdon, et al.                                    |   |
|                   | US-6,677,894-B2   | 01-13-2004                     | Sheynblat, et al.                                  |   |
|                   | US-6,603,977-B1   | 08-05-2003                     | Walsh, et al.                                      |   |

Examiner: /AJIT PATEL/

Date Considered: 05/18/2020

EXAMINER: Initial if reference considered, whether or not citation is in conformance with MPEP 609; Draw line through citation if not in conformance and not considered. Include copy of this form with next communication to applicant.

ALL REFERENCES CONSIDERED EXCEPT WHERE LINED THROUGH. /A.P/

|  |                          |               |
|--|--------------------------|---------------|
| Substitute for form 1449/PTO<br><br><b>INFORMATION DISCLOSURE<br/>STATEMENT BY APPLICANT</b> | <b>Complete if Known</b> |               |
|  | Application Number       | 16/788,498    |
|  | Filing Date              | 2/12/2020     |
|  | First Named Inventor     | Reed          |
|  | Examiner Name            | -- Unknown -- |
|  | Art Unit                 | -- Unknown -- |
|  | Attorney Docket No.      | TX1000-C12    |

| Examiner Initials | Document Number   | Publication Date<br>MM-DD-YYYY | Name of Patentee or<br>Applicant of Cited Document | Pages, Columns, Lines, Where<br>Relevant Passages or Relevant<br>Figures Appear |
|-------------------|-------------------|--------------------------------|--|---|
|                   | US-6,243,030-B1   | 06-05-2001                     | Levine   |   |
|                   | US-6,442,394-B1   | 08-27-2002                     | Valentine, et al.                                  |   |
|                   | US-6,950,745-B2   | 09-27-2005                     | Agnew, et al.                                      |   |
|                   | US-6,853,915-B2   | 02-08-2005                     | Hubschneider, et al.                               |   |
|                   | US-5,911,773      | 06-15-1999                     | Mutsuga, et al.                                    |   |
|                   | US-6,163,751      | 12-19-2000                     | Van Roekel   |   |
|                   | US-6,278,941-B1   | 08-21-2001                     | Yokoyama   |   |
|                   | US-6,341,255-B1   | 01-22-2002                     | Lapidot  |   |
|                   | US-7,260,473-B2   | 08-21-2007                     | Abe, et al.  |   |
|                   | US-6,421,607-B1   | 07-16-2002                     | Gee, et al.  |   |
|                   | US-7,117,085-B2   | 10-03-2006                     | Buecher, et al.                                    |   |
|                   | US-6,317,684-B1   | 11-13-2001                     | Roeseler, et al.                                   |   |
|                   | US-6,484,093-B1   | 11-19-2002                     | Ito, et al.  |   |
|                   | US-6,282,491-B1   | 08-28-2001                     | Bochmann, et al.                                   |   |
|                   | US-5,543,789      | 08-06-1996                     | Behr, et al.                                       |   |
|                   | US-5,839,086      | 11-17-1998                     | Hirano   |   |
|                   | US-6,336,073-B1   | 01-01-2002                     | Ihara, et al.                                      |   |
|                   | US-6,725,155-B1   | 04-20-2004                     | Takahashi, et al.                                  |   |
|                   | US-6,662,105-B1   | 12-09-2003                     | Tada, et al.                                       |   |
|                   | US-6,847,889-B2   | 01-25-2005                     | Park, et al.                                       |   |
|                   | US-6,614,363-B1   | 09-02-2003                     | Behr, et al.                                       |   |
|                   | US-6,084,955      | 07-04-2000                     | Key, et al.  |   |
|                   | US-6,266,514-B1   | 07-24-2001                     | O'Donnell  |   |
|                   | US-7,280,803-B2   | 10-09-2007                     | Nelson   |   |
|                   | US-6,782,256-B2   | 08-24-2004                     | Engholm, et al.                                    |   |
|                   | US-6,317,605-B1   | 11-13-2001                     | Sakuma   |   |
|                   | US-7,333,794-B2   | 02-19-2008                     | Zappala  |   |
|                   | US-6,985,839-B1   | 01-10-2006                     | Motamedi, et al.                                   |   |
|                   | US-7,116,990-B2   | 10-03-2006                     | Maanoja  |   |
|                   | US-20050043036-A1 | 02-24-2005                     | loppe, et al.                                      |   |
|                   | US-7,203,503-B2   | 04-10-2007                     | Cedervall, et al.                                  |   |
|                   | US-6,907,252-B2   | 06-14-2005                     | Papadidas, et al.                                  |   |

Examiner: /AJIT PATEL/

Date Considered: 05/18/2020

EXAMINER: Initial if reference considered, whether or not citation is in conformance with MPEP 609; Draw line through citation if not in conformance and not considered. Include copy of this form with next communication to applicant.

ALL REFERENCES CONSIDERED EXCEPT WHERE LINED THROUGH. /A.P/

|  |                          |               |
|--|--------------------------|---------------|
| Substitute for form 1449/PTO<br><br><b>INFORMATION DISCLOSURE<br/>STATEMENT BY APPLICANT</b> | <b>Complete if Known</b> |               |
|  | Application Number       | 16/788,498    |
|  | Filing Date              | 2/12/2020     |
|  | First Named Inventor     | Reed          |
|  | Examiner Name            | -- Unknown -- |
|  | Art Unit                 | -- Unknown -- |
|  | Attorney Docket No.      | TX1000-C12    |

| Examiner Initials | Document Number   | Publication Date<br>MM-DD-YYYY | Name of Patentee or<br>Applicant of Cited Document | Pages, Columns, Lines, Where<br>Relevant Passages or Relevant<br>Figures Appear |
|-------------------|-------------------|--------------------------------|--|---|
|                   | US-7,996,017-B2   | 08-09-2011                     | Vanttinen  |   |
|                   | US-7,151,940-B2   | 12-19-2006                     | Vanttinen, et al.                                  |   |
|                   | US-6,526,283-B1   | 02-25-2003                     | Jang   |   |
|                   | US-7,574,222-B2   | 08-11-2009                     | Sawada, et al.                                     |   |
|                   | US-6,721,542-B1   | 04-13-2004                     | Anttila, et al.                                    |   |
|                   | US-7,149,201-B2   | 12-12-2006                     | Hunzinger  |   |
|                   | US-7,024,187-B2   | 04-04-2006                     | Moles, et al.                                      |   |
|                   | US-6,298,233-B1   | 10-02-2001                     | Souissi, et al.                                    |   |
|                   | US-6,925,300-B2   | 08-02-2005                     | Horne  |   |
|                   | US-6,073,075      | 06-06-2000                     | Kondou   |   |
|                   | US-6,941,220-B2   | 09-06-2005                     | Le, et al.   |   |
|                   | US-7,162,367-B2   | 01-09-2007                     | Lin, et al.  |   |
|                   | US-20030199260-A1 | 10-23-2003                     | Casey, et al.                                      |   |
|                   | US-20040246147-A1 | 12-09-2004                     | Von Grabe  |   |
|                   | US-7,164,921-B2   | 01-16-2007                     | Owens, et al.                                      |   |
|                   | US-6,456,854-B1   | 09-24-2002                     | Chern, et al.                                      |   |
|                   | US-6,944,447-B2   | 09-13-2005                     | Portman, et al.                                    |   |
|                   | US-20020002504-A1 | 01-03-2002                     | Engel, et al.                                      |   |
|                   | US-5,835,061      | 11-10-1998                     | Stewart  |   |
|                   | US-6,650,902-B1   | 11-18-2003                     | Richton  |   |
|                   | US-6,836,667-B1   | 12-28-2004                     | Smith, Jr.   |   |
|                   | US-7,024,205-B1   | 04-04-2006                     | Hose   |   |
|                   | US-7,076,244-B2   | 07-11-2006                     | Lazaridis, et al.                                  |   |
|                   | US-20030004743-A1 | 01-02-2003                     | Callegari  |   |
|                   | US-20020161633-A1 | 10-31-2002                     | Jacob, et al.                                      |   |
|                   | US-7,103,368-B2   | 09-05-2006                     | Teshima  |   |
|                   | US-7,813,741-B2   | 10-12-2010                     | Hendrey, et al.                                    |   |
|                   | US-20020091568-A1 | 07-11-2002                     | Kraft, et al.                                      |   |
|                   | US-6,798,358-B2   | 09-28-2004                     | Joyce, et al.                                      |   |
|                   | US-20020111154-A1 | 08-15-2002                     | Eldering, et al.                                   |   |
|                   | US-7,089,264-B1   | 08-08-2006                     | Guido, et al.                                      |   |
|                   | US-6,816,720-B2   | 11-09-2004                     | Hussain, et al.                                    |   |

Examiner: /AJIT PATEL/

Date Considered: 05/18/2020

EXAMINER: Initial if reference considered, whether or not citation is in conformance with MPEP 609; Draw line through citation if not in conformance and not considered. Include copy of this form with next communication to applicant.

ALL REFERENCES CONSIDERED EXCEPT WHERE LINED THROUGH. /A.P/

|  |                          |               |
|--|--------------------------|---------------|
| Substitute for form 1449/PTO<br><br><b>INFORMATION DISCLOSURE<br/>STATEMENT BY APPLICANT</b> | <b>Complete if Known</b> |               |
|  | Application Number       | 16/788,498    |
|  | Filing Date              | 2/12/2020     |
|  | First Named Inventor     | Reed          |
|  | Examiner Name            | -- Unknown -- |
|  | Art Unit                 | -- Unknown -- |
|  | Attorney Docket No.      | TX1000-C12    |

| Examiner Initials | Document Number   | Publication Date<br>MM-DD-YYYY | Name of Patentee or<br>Applicant of Cited Document | Pages, Columns, Lines, Where<br>Relevant Passages or Relevant<br>Figures Appear |
|-------------------|-------------------|--------------------------------|--|---|
|                   | US-6,795,710-B1   | 09-21-2004                     | Creemer  |   |
|                   | US-6,157,841      | 12-05-2000                     | Bolduc, et al.                                     |   |
|                   | US-6,580,914-B1   | 06-17-2003                     | Smith  |   |
|                   | US-6,014,090      | 01-11-2000                     | Rosen, et al.                                      |   |
|                   | US-6,970,922-B1   | 11-29-2005                     | Spector  |   |
|                   | US-6,492,944-B1   | 12-10-2002                     | Stilp  |   |
|                   | US-5,519,760      | 05-21-1996                     | Borkowski, et al.                                  |   |
|                   | US-6,321,092-B1   | 11-20-2001                     | Fitch, et al.                                      |   |
|                   | US-6,456,852-B2   | 09-24-2002                     | Bar, et al.  |   |
|                   | US-6,317,604-B1   | 11-13-2001                     | Kovach, Jr., et al.                                |   |
|                   | US-6,952,181-B2   | 10-04-2005                     | Karr, et al.                                       |   |
|                   | US-6,236,365-B1   | 05-22-2001                     | LeBlanc, et al.                                    |   |
|                   | US-6,961,562-B2   | 11-01-2005                     | Ross   |   |
|                   | US-7,123,918-B1   | 10-17-2006                     | Goodman  |   |
|                   | US-20040093289-A1 | 05-13-2004                     | Bodin  |   |
|                   | US-6,557,139-B2   | 04-29-2003                     | Bohnke   |   |
|                   | US-6,233,449-B1   | 05-15-2001                     | Glitho, et al.                                     |   |
|                   | US-7,689,240-B2   | 03-30-2010                     | Anderson   |   |
|                   | US-6,839,554-B2   | 01-04-2005                     | McDowell, et al.                                   |   |
|                   | US-20020035605-A1 | 03-21-2002                     | McDowell, et al.                                   |   |
|                   | US-7,546,128-B2   | 06-09-2009                     | Smith, et al.                                      |   |
|                   | US-6,842,620-B2   | 01-11-2005                     | Smith, et al.                                      |   |
|                   | US-5,588,048      | 12-24-1996                     | Neville  |   |
|                   | US-20030003900-A1 | 01-02-2003                     | Goss, et al.                                       |   |
|                   | US-7,616,950-B2   | 11-10-2009                     | Pearson, et al.                                    |   |
|                   | US-8,862,106-B2   | 10-14-2014                     | Salisbury, et al.                                  |   |
|                   | US-RE42,937 E     | 11-15-2011                     | Want, et al.                                       |   |
|                   | US-6,847,969-B1   | 01-25-2005                     | Mathai, et al.                                     |   |
|                   | US-6,671,646-B2   | 12-30-2003                     | Manegold, et al.                                   |   |
|                   | US-7,808,369-B2   | 10-05-2010                     | Brinton, et al.                                    |   |
|                   | US-4,818,998      | 04-04-1989                     | Apsell, et al.                                     |   |

Examiner: /AJIT PATEL/

Date Considered: 05/18/2020

EXAMINER: Initial if reference considered, whether or not citation is in conformance with MPEP 609; Draw line through citation if not in conformance and not considered. Include copy of this form with next communication to applicant.

ALL REFERENCES CONSIDERED EXCEPT WHERE LINED THROUGH. /A.P/

|  |                          |               |
|--|--------------------------|---------------|
| Substitute for form 1449/PTO<br><br><b>INFORMATION DISCLOSURE<br/>STATEMENT BY APPLICANT</b> | <b>Complete if Known</b> |               |
|  | Application Number       | 16/788,498    |
|  | Filing Date              | 2/12/2020     |
|  | First Named Inventor     | Reed          |
|  | Examiner Name            | -- Unknown -- |
|  | Art Unit                 | -- Unknown -- |
|  | Attorney Docket No.      | TX1000-C12    |

| Examiner Initials | Document Number   | Publication Date<br>MM-DD-YYYY | Name of Patentee or<br>Applicant of Cited Document | Pages, Columns, Lines, Where<br>Relevant Passages or Relevant<br>Figures Appear |
|-------------------|-------------------|--------------------------------|--|---|
|                   | US-7,564,375-B2   | 07-21-2009                     | Brinton, et al.                                    |   |
|                   | US-7,362,229-B2   | 04-22-2008                     | Brinton, et al.                                    |   |
|                   | US-7,557,696-B2   | 07-07-2009                     | Brinton, et al.                                    |   |
|                   | US-6,804,626-B2   | 10-12-2004                     | Manegold, et al.                                   |   |
|                   | US-7,117,121-B2   | 10-03-2006                     | Brinton, et al.                                    |   |
|                   | US-5,272,638      | 12-21-1993                     | Martin, et al.                                     |   |
|                   | US-5,465,289      | 11-07-1995                     | Kennedy, Jr.                                       |   |
|                   | US-5,745,865      | 04-28-1998                     | Rostoker, et al.                                   |   |
|                   | US-6,343,290-B1   | 01-29-2002                     | Cossins, et al.                                    |   |
|                   | US-5,844,522      | 12-01-1998                     | Sheffer, et al.                                    |   |
|                   | US-5,987,329      | 11-16-1999                     | Yost, et al.                                       |   |
|                   | US-5,930,717      | 07-27-1999                     | Yost, et al.                                       |   |
|                   | US-6,539,229-B1   | 03-25-2003                     | Ali  |   |
|                   | US-6,662,023-B1   | 12-09-2003                     | Helle  |   |
|                   | US-6,225,944-B1   | 05-01-2001                     | Hayes  |   |
|                   | US-6,246,861-B1   | 06-12-2001                     | Messier, et al.                                    |   |
|                   | US-6,097,336      | 08-01-2000                     | Stilp  |   |
|                   | US-6,385,458-B1   | 05-07-2002                     | Papadimitriou, et al.                              |   |
|                   | US-7,519,372-B2   | 04-14-2009                     | MacDonald, et al.                                  |   |
|                   | US-6,243,588-B1   | 06-05-2001                     | Koorapaty, et al.                                  |   |
|                   | US-5,524,136      | 06-04-1996                     | Bar-Noy, et al.                                    |   |
|                   | US-6,674,403-B2   | 01-06-2004                     | Gray, et al.                                       |   |
|                   | US-20020169539-A1 | 11-14-2002                     | Menard, et al.                                     |   |
|                   | US-5,890,068      | 03-30-1999                     | Fattouche, et al.                                  |   |
|                   | US-6,330,452-B1   | 12-11-2001                     | Fattouche, et al.                                  |   |
|                   | US-7,130,630-B1   | 10-31-2006                     | Enzmann, et al.                                    |   |
|                   | US-7,133,909-B2   | 11-07-2006                     | Bahl   |   |
|                   | US-6,236,335-B1   | 05-22-2001                     | Goodwin, III                                       |   |
|                   | US-6,716,101-B1   | 04-06-2004                     | Meadows, et al.                                    |   |
|                   | US-7,525,484-B2   | 04-28-2009                     | Dupray, et al.                                     |   |
|                   | US-8,082,096-B2   | 12-20-2011                     | Dupray   |   |

Examiner: /AJIT PATEL/

Date Considered: 05/18/2020

EXAMINER: Initial if reference considered, whether or not citation is in conformance with MPEP 609; Draw line through citation if not in conformance and not considered. Include copy of this form with next communication to applicant.

ALL REFERENCES CONSIDERED EXCEPT WHERE LINED THROUGH. /A.P/

|  |                          |               |
|--|--------------------------|---------------|
| Substitute for form 1449/PTO<br><br><b>INFORMATION DISCLOSURE<br/>STATEMENT BY APPLICANT</b> | <b>Complete if Known</b> |               |
|  | Application Number       | 16/788,498    |
|  | Filing Date              | 2/12/2020     |
|  | First Named Inventor     | Reed          |
|  | Examiner Name            | -- Unknown -- |
|  | Art Unit                 | -- Unknown -- |
|  | Attorney Docket No.      | TX1000-C12    |

| Examiner Initials | Document Number   | Publication Date<br>MM-DD-YYYY | Name of Patentee or<br>Applicant of Cited Document | Pages, Columns, Lines, Where<br>Relevant Passages or Relevant<br>Figures Appear |
|-------------------|-------------------|--------------------------------|--|---|
|                   | US-20030146871-A1 | 08-07-2003                     | Karr, et al.                                       |   |
|                   | US-9,134,398-B2   | 09-15-2015                     | Dupray, et al.                                     |   |
|                   | US-7,274,332-B1   | 09-25-2007                     | Dupray   |   |
|                   | US-6,466,565-B1   | 10-15-2002                     | Wax, et al.  |   |
|                   | US-6,111,538      | 08-29-2000                     | Schuchman, et al.                                  |   |
|                   | US-8,994,591-B2   | 03-31-2015                     | Dupray, et al.                                     |   |
|                   | US-6,204,813-B1   | 03-20-2001                     | Wadell, et al.                                     |   |
|                   | US-6,064,339      | 05-16-2000                     | Wax, et al.  |   |
|                   | US-7,020,475-B2   | 03-28-2006                     | Bahl, et al.                                       |   |
|                   | US-6,799,047-B1   | 09-28-2004                     | Bahl, et al.                                       |   |
|                   | US-6,026,304      | 02-15-2000                     | Hilsenrath, et al.                                 |   |
|                   | US-6,393,294-B1   | 05-21-2002                     | Perez-Breva, et al.                                |   |
|                   | US-6,269,246-B1   | 07-31-2001                     | Rao, et al.  |   |
|                   | US-7,164,883-B2   | 01-16-2007                     | Rappaport, et al.                                  |   |
|                   | US-7,664,492-B1   | 02-16-2010                     | Lee, et al.  |   |
|                   | US-7,043,254-B2   | 05-09-2006                     | Chawla, et al.                                     |   |
|                   | US6,973,622-B1    | 12-06-2005                     | Rappaport, et al.                                  |   |
|                   | US-6,631,267-B1   | 10-07-2003                     | Clarkson, et al.                                   |   |
|                   | US-6,842,431-B2   | 01-11-2005                     | Clarkson, et al.                                   |   |
|                   | US-7,120,431-B1   | 10-10-2006                     | Huo, et al.  |   |
|                   | US-20030054811-A1 | 03-20-2003                     | Han, et al.  |   |
|                   | US-7,319,847-B2   | 01-15-2008                     | Xanthos, et al.                                    |   |
|                   | US-6,587,690-B1   | 07-01-2003                     | Di Huo, et al.                                     |   |
|                   | US-7,096,160-B2   | 08-22-2006                     | Skidmore, et al.                                   |   |
|                   | US-20020155816-A1 | 10-24-2002                     | Fodor, et al.                                      |   |
|                   | US-5,920,607      | 07-06-1999                     | Berg   |   |
|                   | US-9,528,843-B2   | 12-27-2016                     | Pu, et al.   |   |
|                   | US-7,003,264-B2   | 02-21-2006                     | Fodor, et al.                                      |   |
|                   | US-5,799,154      | 08-25-1998                     | Kuriyan  |   |
|                   | US-20020152303-A1 | 10-17-2002                     | Dispensa   |   |
|                   | US-6,839,552-B1   | 01-04-2005                     | Martin   |   |

Examiner:

/AJIT PATEL/

Date Considered:

05/18/2020

EXAMINER: Initial if reference considered, whether or not citation is in conformance with MPEP 609; Draw line through citation if not in conformance and not considered. Include copy of this form with next communication to applicant.

ALL REFERENCES CONSIDERED EXCEPT WHERE LINED THROUGH. /A.P/

|  |                          |               |
|--|--------------------------|---------------|
| Substitute for form 1449/PTO<br><br><b>INFORMATION DISCLOSURE<br/>STATEMENT BY APPLICANT</b> | <b>Complete if Known</b> |               |
|  | Application Number       | 16/788,498    |
|  | Filing Date              | 2/12/2020     |
|  | First Named Inventor     | Reed          |
|  | Examiner Name            | -- Unknown -- |
|  | Art Unit                 | -- Unknown -- |
|  | Attorney Docket No.      | TX1000-C12    |

| Examiner Initials | Document Number   | Publication Date<br>MM-DD-YYYY | Name of Patentee or<br>Applicant of Cited Document | Pages, Columns, Lines, Where<br>Relevant Passages or Relevant<br>Figures Appear |
|-------------------|-------------------|--------------------------------|--|---|
|                   | US-6,088,588      | 07-11-2000                     | Osborne  |   |
|                   | US-6,745,011-B1   | 06-01-2004                     | Hendrickson, et al.                                |   |
|                   | US-6,751,443-B2   | 06-15-2004                     | Haymes, et al.                                     |   |
|                   | US-6,650,896-B1   | 11-18-2003                     | Haymes, et al.                                     |   |
|                   | US-7,079,945-B1   | 07-18-2006                     | Kaplan   |   |
|                   | US-6,374,177-B1   | 04-16-2002                     | Lee, et al.  |   |
|                   | US-20020164998-A1 | 11-07-2002                     | Younis   |   |
|                   | US-20030065442-A1 | 04-03-2003                     | Touney   |   |
|                   | US-6,405,123-B1   | 06-11-2002                     | Rennard, et al.                                    |   |
|                   | US-6,615,131-B1   | 09-02-2003                     | Rennard, et al.                                    |   |
|                   | US-20020115453-A1 | 08-22-2002                     | Poulin, et al.                                     |   |
|                   | US-6,725,156-B2   | 04-20-2004                     | Kaplan   |   |
|                   | US-6,947,837-B2   | 09-20-2005                     | Fukushima, et al.                                  |   |
|                   | US-7,149,625-B2   | 12-12-2006                     | Mathews, et al.                                    |   |
|                   | US-20020194498-A1 | 12-19-2002                     | Blight, et al.                                     |   |
|                   | US-6,609,005-B1   | 08-19-2003                     | Chern  |   |
|                   | US 6,662,014-B1   | 12-09-2003                     | Walsh  |   |
|                   | US 5,023,900      | 06-11-1991                     | Tayloe, et al.                                     |   |
|                   | US 7,203,752-B2   | 04-10-2007                     | Rice, et al.                                       |   |
|                   | US 20020173318-A1 | 11-21-2002                     | Dyer   |   |
|                   | US 5,812,636      | 09-22-1998                     | Tseng, et al.                                      |   |
|                   | US 6,223,032-B1   | 04-24-2001                     | Cuffaro  |   |
|                   | US 6,266,013-B1   | 07-24-2001                     | Stilp, et al.                                      |   |
|                   | US 6,138,003      | 10-24-2000                     | Kingdon, et al.                                    |   |
|                   | US 6,757,543-B2   | 06-29-2004                     | Moran, et al.                                      |   |
|                   | US 6,904,013-B2   | 06-07-2005                     | Skoog, et al.                                      |   |
|                   | US 6,430,397-B1   | 08-06-2002                     | Willrett   |   |
|                   | US 20010049263-A1 | 12-06-2001                     | Zhang  |   |
|                   | US-6,360,102-B1   | 03-19-2002                     | Havinis, et al.                                    |   |
|                   | US-6,442,391-B1   | 08-27-2002                     | Johansson, et al.                                  |   |

Examiner:

/AJIT PATEL/

Date Considered:

05/18/2020

EXAMINER: Initial if reference considered, whether or not citation is in conformance with MPEP 609; Draw line through citation if not in conformance and not considered. Include copy of this form with next communication to applicant.

ALL REFERENCES CONSIDERED EXCEPT WHERE LINED THROUGH. /A.P/

|  |                          |               |
|--|--------------------------|---------------|
| Substitute for form 1449/PTO<br><br><b>INFORMATION DISCLOSURE<br/>STATEMENT BY APPLICANT</b> | <b>Complete if Known</b> |               |
|  | Application Number       | 16/788,498    |
|  | Filing Date              | 2/12/2020     |
|  | First Named Inventor     | Reed          |
|  | Examiner Name            | -- Unknown -- |
|  | Art Unit                 | -- Unknown -- |
|  | Attorney Docket No.      | TX1000-C12    |

| Examiner Initials | Document Number   | Publication Date MM-DD-YYYY | Name of Patentee or Applicant of Cited Document | Pages, Columns, Lines, Where Relevant Passages or Relevant Figures Appear |
|-------------------|-------------------|-----------------------------|---|---|
|                   | US-6,636,744-B1   | 10-21-2003                  | Da  |   |
|                   | US-4,912,705      | 03-27-1990                  | Paneth, et al.                                  |   |
|                   | US-5,526,357      | 06-11-1996                  | Jandrell  |   |
|                   | US-5,548,583      | 08-20-1996                  | Bustamante                                      |   |
|                   | US-20020198985-A1 | 12-26-2002                  | Fraenkel, et al.                                |   |
|                   | US-20030091017-A1 | 05-15-2003                  | Davenport, et al.                               |   |
|                   | US-20050282540-A1 | 12-22-2005                  | Motamedi, et al.                                |   |
|                   | US-6,505,048-B1   | 01-07-2003                  | Moles, et al.                                   |   |
|                   | US-7,085,555-B2   | 08-01-2006                  | Zellner, et al.                                 |   |
|                   | US-6,678,516-B2   | 01-13-2004                  | Nordman, et al.                                 |   |
|                   | US-5,471,649      | 11-28-1995                  | Rees, et al.                                    |   |
|                   | US-5,857,155      | 01-05-1999                  | Hill, et al.                                    |   |
|                   | US-5,425,076      | 06-13-1995                  | Knippelmier                                     |   |
|                   | US-6,445,917-B1   | 09-03-2002                  | Bark, et al.                                    |   |
|                   | US-6,859,463-B1   | 02-22-2005                  | Mayor, et al.                                   |   |
|                   | US-6,188,883-B1   | 02-13-2001                  | Takemura  |   |
|                   | US-6,128,507      | 10-03-2000                  | Takai   |   |
|                   | US-5,875,398      | 02-23-1999                  | Snapp   |   |
|                   | US-6,285,688-B1   | 09-04-2001                  | Henderson, et al.                               |   |
|                   | US-6,839,560-B1   | 01-04-2005                  | Bahl, et al.                                    |   |
|                   | US-6,353,902-B1   | 03-05-2002                  | Kulatunge, et al.                               |   |
|                   | US-6,453,152-B1   | 09-17-2002                  | Hong, et al.                                    |   |
|                   | US-5,245,610      | 09-14-1993                  | Lindell   |   |
|                   | US-5,694,451      | 12-02-1997                  | Arinell   |   |
|                   | US-6,226,589-B1   | 05-01-2001                  | Maeda, et al.                                   |   |
|                   | US-6,687,504-B1   | 02-03-2004                  | Raith   |   |
|                   | US-6,317,596-B1   | 11-13-2001                  | Elwin   |   |
|                   | US-5,570,373      | 10-29-1996                  | Wing  |   |
|                   | US-5,790,940      | 08-04-1998                  | Laborde, et al.                                 |   |
|                   | US-5,757,810      | 05-26-1998                  | Fall  |   |

Examiner: /AJIT PATEL/

Date Considered: 05/18/2020

EXAMINER: Initial if reference considered, whether or not citation is in conformance with MPEP 609; Draw line through citation if not in conformance and not considered. Include copy of this form with next communication to applicant.

ALL REFERENCES CONSIDERED EXCEPT WHERE LINED THROUGH. /A.P/



|  |                          |               |
|--|--------------------------|---------------|
| Substitute for form 1449/PTO<br><br><b>INFORMATION DISCLOSURE<br/>STATEMENT BY APPLICANT</b> | <b>Complete if Known</b> |               |
|  | Application Number       | 16/788,498    |
|  | Filing Date              | 2/12/2020     |
|  | First Named Inventor     | Reed          |
|  | Examiner Name            | -- Unknown -- |
|  | Art Unit                 | -- Unknown -- |
|  | Attorney Docket No.      | TX1000-C12    |

| Examiner Initials | Document Number   | Publication Date<br>MM-DD-YYYY | Name of Patentee or<br>Applicant of Cited Document | Pages, Columns, Lines, Where<br>Relevant Passages or Relevant<br>Figures Appear |
|-------------------|-------------------|--------------------------------|--|---|
|                   | US-5,884,163      | 03-16-1999                     | Hardouin   |   |
|                   | US-5,802,473      | 09-01-1998                     | Rutledge, et al.                                   |   |
|                   | US-6,445,916-B1   | 09-03-2002                     | Rahman   |   |
|                   | US-6,154,638      | 11-28-2000                     | Cheng, et al.                                      |   |
|                   | US-7,093,286-B1   | 08-15-2006                     | King   |   |
|                   | US-6,442,393-B1   | 08-27-2002                     | Hogan  |   |
|                   | US-5,603,093      | 02-11-1997                     | Yoshimi, et al.                                    |   |
|                   | US-5,706,333      | 01-06-1998                     | Grenning, et al.                                   |   |
|                   | US-6,640,101-B1   | 10-28-2003                     | Daniel   |   |
|                   | US-6,144,861      | 11-07-2000                     | Sundelin, et al.                                   |   |
|                   | US-20020072358-A1 | 06-13-2002                     | Schneider, et al.                                  |   |
|                   | US-6,487,394-B1   | 11-26-2002                     | Ue, et al.   |   |
|                   | US-6,847,916-B1   | 01-25-2005                     | Ying   |   |
|                   | US-5,933,776      | 08-03-1999                     | Kirkpatrick  |   |
|                   | US-6,560,461-B1   | 05-06-2003                     | Fomukong, et al.                                   |   |
|                   | US-6,072,778      | 06-06-2000                     | Labedz, et al.                                     |   |
|                   | US-6,061,561      | 05-09-2000                     | Alanara, et al.                                    |   |
|                   | US-5,819,177      | 10-06-1998                     | Vucetic, et al.                                    |   |
|                   | US-6,775,544-B2   | 08-10-2004                     | Ficarra  |   |
|                   | US-6,594,483-B2   | 07-15-2003                     | Nykanen, et al.                                    |   |
|                   | US-8,199,696-B2   | 06-12-2012                     | Sarkar, et al.                                     |   |
|                   | US-7,072,648-B2   | 07-04-2006                     | Ichikawa   |   |
|                   | US-6,070,083      | 05-30-2000                     | Watters, et al.                                    |   |
|                   | US-5,952,969      | 09-14-1999                     | Hagerman, et al.                                   |   |
|                   | US-6,385,465-B1   | 05-07-2002                     | Yoshioka   |   |
|                   | US-20010044310-A1 | 11-22-2001                     | Lincke   |   |
|                   | US-6,850,766-B2   | 02-01-2005                     | Lau, et al.  |   |
|                   | US-6,757,718-B1   | 06-29-2004                     | Halverson, et al.                                  |   |
|                   | US-6,487,495-B1   | 11-26-2002                     | Gale, et al.                                       |   |
|                   | US-5,428,663      | 06-27-1995                     | Grimes, et al.                                     |   |

Examiner: /AJIT PATEL/

Date Considered: 05/18/2020

EXAMINER: Initial if reference considered, whether or not citation is in conformance with MPEP 609; Draw line through citation if not in conformance and not considered. Include copy of this form with next communication to applicant.

ALL REFERENCES CONSIDERED EXCEPT WHERE LINED THROUGH. /A.P/

|  |                          |               |
|--|--------------------------|---------------|
| Substitute for form 1449/PTO<br><br><b>INFORMATION DISCLOSURE<br/>STATEMENT BY APPLICANT</b> | <b>Complete if Known</b> |               |
|  | Application Number       | 16/788,498    |
|  | Filing Date              | 2/12/2020     |
|  | First Named Inventor     | Reed          |
|  | Examiner Name            | -- Unknown -- |
|  | Art Unit                 | -- Unknown -- |
| Attorney Docket No.  | TX1000-C12               |               |

| Examiner Initials | Document Number   | Publication Date<br>MM-DD-YYYY | Name of Patentee or<br>Applicant of Cited Document | Pages, Columns, Lines, Where<br>Relevant Passages or Relevant<br>Figures Appear |
|-------------------|-------------------|--------------------------------|--|---|
|                   | US-6,320,534-B1   | 11-20-2001                     | Goss   |   |
|                   | US-5,142,654      | 08-25-1992                     | Sonberg, et al.                                    |   |
|                   | US-5,497,412      | 03-05-1996                     | Lannen, et al.                                     |   |
|                   | US-6,052,591      | 04-18-2000                     | Bhatia   |   |
|                   | US-7,603,411-B1   | 10-13-2009                     | Davies, et al.                                     |   |
|                   | US-5,895,436      | 04-20-1999                     | Savoie, et al.                                     |   |
|                   | US-6,453,181-B1   | 09-17-2002                     | Challa, et al.                                     |   |
|                   | US-6,735,454-B1   | 05-11-2004                     | Yu, et al.   |   |
|                   | US-6,944,452-B2   | 09-13-2005                     | Coskun, et al.                                     |   |
|                   | US-6,466,790-B2   | 10-15-2002                     | Haumont, et al.                                    |   |
|                   | US-5,659,596      | 08-19-1997                     | Dunn   |   |
|                   | US-6,266,615      | 07-24-2001                     | Jin  |   |
|                   | US-6,515,595-B1   | 02-04-2003                     | Obradovich, et al.                                 |   |
|                   | US-6,553,308-B1   | 04-22-2003                     | Uhlmann, et al.                                    |   |
|                   | US-7,421,486-B1   | 09-02-2008                     | Parupudi, et al.                                   |   |
|                   | US-8,019,581-B2   | 09-13-2011                     | Sheha, et al.                                      |   |
|                   | US-6,680,694-B1   | 01-20-2004                     | Knockeart, et al.                                  |   |
|                   | US-6,377,810-B1   | 04-23-2002                     | Geiger, et al.                                     |   |
|                   | US-6,853,911-B1   | 02-08-2005                     | Sakarya  |   |
|                   | US-20030040340-A1 | 02-27-2003                     | Smethers   |   |
|                   | US-6,522,888-B1   | 02-18-2003                     | Garceran, et al.                                   |   |
|                   | US-6,603,966-B1   | 02-05-2003                     | Sheffield  |   |
|                   | US-6,097,953      | 08-01-2000                     | Bonta  |   |
|                   | US-6,900,775-B2   | 05-31-2005                     | Shapira  |   |
|                   | US-6,141,565      | 10-31-2000                     | Feuerstein, et al.                                 |   |
|                   | US-20030069043-A1 | 04-10-2003                     | Chhaochharia, et al.                               |   |
|                   | US-5,519,830      | 05-21-1996                     | Opoczynski   |   |
|                   | US-5,878,328      | 03-02-1999                     | Chawla, et al.                                     |   |
|                   | US-6,035,183      | 03-07-2000                     | Todd, et al.                                       |   |
|                   | US-5,654,908      | 08-05-1997                     | Yokoyama   |   |

Examiner: /AJIT PATEL/

Date Considered: 05/18/2020

EXAMINER: Initial if reference considered, whether or not citation is in conformance with MPEP 609; Draw line through citation if not in conformance and not considered. Include copy of this form with next communication to applicant.

ALL REFERENCES CONSIDERED EXCEPT WHERE LINED THROUGH. /A.P/

|  |                          |               |
|--|--------------------------|---------------|
| Substitute for form 1449/PTO<br><br><b>INFORMATION DISCLOSURE<br/>STATEMENT BY APPLICANT</b> | <b>Complete if Known</b> |               |
|  | Application Number       | 16/788,498    |
|  | Filing Date              | 2/12/2020     |
|  | First Named Inventor     | Reed          |
|  | Examiner Name            | -- Unknown -- |
|  | Art Unit                 | -- Unknown -- |
|  | Attorney Docket No.      | TX1000-C12    |

| Examiner Initials | Document Number | Publication Date<br>MM-DD-YYYY | Name of Patentee or<br>Applicant of Cited Document | Pages, Columns, Lines, Where<br>Relevant Passages or Relevant<br>Figures Appear |
|-------------------|-----------------|--------------------------------|--|---|
|                   | US-4,689,747    | 08-25-1987                     | Kurose, et al.                                     |   |
|                   | US-5,684,859    | 11-04-1997                     | Chanroo, et al.                                    |   |
|                   | US-5,774,829    | 06-30-1998                     | Cisneros, et al.                                   |   |
|                   | US-6,104,931    | 08-15-2000                     | Havinis, et al.                                    |   |
|                   | US-6,198,910-B1 | 03-06-2001                     | Hanley   |   |
|                   | US-6,240,365-B1 | 05-29-2001                     | Bunn   |   |
|                   | US-6,212,474-B1 | 04-03-2001                     | Fowler, et al.                                     |   |
|                   | US-6,249,679-B1 | 06-19-2001                     | Guilbaud, et al.                                   |   |
|                   | US-6,266,014-B1 | 07-24-2001                     | Fattouche, et al.                                  |   |
|                   | US-6,278,939-B1 | 08-21-2001                     | Robare, et al.                                     |   |
|                   | US-6,285,321-B1 | 09-04-2001                     | Stilp, et al.                                      |   |
|                   | US-6,297,766-B1 | 10-02-2001                     | Koeller  |   |
|                   | US-6,307,573-B1 | 10-23-2001                     | Barros   |   |
|                   | US-6,314,294-B1 | 11-06-2001                     | Benveniste   |   |
|                   | US-6,334,089-B2 | 12-25-2001                     | Hessing  |   |
|                   | US-6,438,490-B2 | 08-20-2002                     | Ohta   |   |
|                   | US-6,456,234-B1 | 09-24-2002                     | Johnson  |   |
|                   | US-6,505,049-B1 | 01-07-2003                     | Dorenbosch   |   |
|                   | US-6,516,195-B1 | 02-04-2003                     | Zadeh, et al.                                      |   |
|                   | US-6,597,906-B1 | 07-22-2003                     | Van Leeuwen, et al.                                |   |
|                   | US-6,611,500-B1 | 08-26-2003                     | Clarkson, et al.                                   |   |
|                   | US-6,654,682-B2 | 11-25-2003                     | Kane, et al.                                       |   |
|                   | US-6,665,676-B2 | 12-16-2003                     | Twig, et al.                                       |   |
|                   | US-6,838,998-B1 | 01-04-2005                     | Brown, et al.                                      |   |
|                   | US-6,985,901-B1 | 01-10-2006                     | Sachse, et al.                                     |   |
|                   | US-7,000,015-B2 | 02-14-2006                     | Moore, et al.                                      |   |
|                   | US-7,072,667-B2 | 07-04-2006                     | Olrik, et al.                                      |   |
|                   | US-7,072,676-B1 | 07-04-2006                     | Hessing, et al.                                    |   |
|                   | US-7,115,990-B2 | 10-03-2006                     | Kinsman  |   |
|                   | US-7,142,863-B1 | 11-28-2006                     | Smith, et al.                                      |   |
|                   | US-7,181,225-B1 | 02-20-2007                     | Moton, Jr. et al.                                  |   |

Examiner: /AJIT PATEL/

Date Considered: 05/18/2020

EXAMINER: Initial if reference considered, whether or not citation is in conformance with MPEP 609; Draw line through citation if not in conformance and not considered. Include copy of this form with next communication to applicant.

ALL REFERENCES CONSIDERED EXCEPT WHERE LINED THROUGH. /A.P/

|  |                          |               |
|--|--------------------------|---------------|
| Substitute for form 1449/PTO<br><br><b>INFORMATION DISCLOSURE<br/>STATEMENT BY APPLICANT</b> | <b>Complete if Known</b> |               |
|  | Application Number       | 16/788,498    |
|  | Filing Date              | 2/12/2020     |
|  | First Named Inventor     | Reed          |
|  | Examiner Name            | -- Unknown -- |
|  | Art Unit                 | -- Unknown -- |
|  | Attorney Docket No.      | TX1000-C12    |

| Examiner Initials | Document Number   | Publication Date<br>MM-DD-YYYY | Name of Patentee or<br>Applicant of Cited Document | Pages, Columns, Lines, Where<br>Relevant Passages or Relevant<br>Figures Appear |
|-------------------|-------------------|--------------------------------|--|---|
|                   | US-7,343,165-B2   | 03-11-2008                     | Obradovich   |   |
|                   | US-7,444,156-B2   | 10-28-2008                     | Boss, et al.                                       |   |
|                   | US-7,558,696-B2   | 07-07-2009                     | Vilppula, et al.                                   |   |
|                   | US-8,107,608-B2   | 01-31-2012                     | Sheha, et al.                                      |   |
|                   | US-8,244,307-B1   | 08-14-2012                     | Tilgner, et al.                                    |   |
|                   | US-8,509,412-B2   | 08-13-2013                     | Sheha, et al.                                      |   |
|                   | US-9,451,019-B2   | 09-20-2016                     | Herz, et al.                                       |   |
|                   | US-7,158,880-B2   | 01-02-2007                     | Geiger, et al.                                     |   |
|                   | US-20010036224-A1 | 11-01-2001                     | Demello, et al.                                    |   |
|                   | US-20020032521-A1 | 03-14-2002                     | Machii, et al.                                     |   |
|                   | US-6,700,534-B2   | 03-02-2004                     | Harris   |   |
|                   | US-6,738,711-B2   | 05-18-2004                     | Ohmura, et al.                                     |   |
|                   | US-7,409,429-B2   | 08-05-2008                     | Kaufman, et al.                                    |   |
|                   | US-20020184418-A1 | 12-05-2002                     | Blight   |   |
|                   | US-20030005316-A1 | 01-02-2003                     | Girard   |   |
|                   | US-7,249,100-B2   | 07-24-2007                     | Murto, et al.                                      |   |
|                   | US-6,198,935-B1   | 03-06-2001                     | Saha, et al.                                       |   |
|                   | US-7,570,958-B2   | 08-04-2009                     | Krasner, et al.                                    |   |
|                   | US-5,808,566      | 09-15-1998                     | Behr, et al.                                       |   |
|                   | US-5,951,620      | 09-14-1999                     | Ahrens, et al.                                     |   |
|                   | US-6,298,301-B1   | 10-02-2001                     | Kim  |   |
|                   | US-6,496,776-B1   | 12-17-2002                     | Blumberg, et al.                                   |   |
|                   | US-7,126,527-B2   | 10-24-2006                     | Bajikar  |   |
|                   | US-7,213,048-B1   | 05-01-2007                     | Parupudi, et al.                                   |   |
|                   | US-5,295,180      | 03-15-1994                     | Vendetti, et al.                                   |   |
|                   | US-6,912,376-B1   | 06-28-2005                     | Smith, et al.                                      |   |
|                   | US-6,236,359-B1   | 05-22-2001                     | Watters, et al.                                    |   |
|                   | US-5,806,018      | 09-08-1998                     | Smith, et al.                                      |   |
|                   | US-6,850,736-B2   | 02-01-2005                     | McCune, Jr.  |   |
|                   | US-6,243,568-B2   | 06-05-2001                     | Detlef, et al.                                     |   |
|                   | US-6,351,221-B1   | 02-26-2002                     | Phillips, et al.                                   |   |

Examiner: /AJIT PATEL/

Date Considered: 05/18/2020

EXAMINER: Initial if reference considered, whether or not citation is in conformance with MPEP 609; Draw line through citation if not in conformance and not considered. Include copy of this form with next communication to applicant.

ALL REFERENCES CONSIDERED EXCEPT WHERE LINED THROUGH. /A.P/



|  |                          |               |
|--|--------------------------|---------------|
| Substitute for form 1449/PTO<br><br><b>INFORMATION DISCLOSURE<br/>STATEMENT BY APPLICANT</b> | <b>Complete if Known</b> |               |
|  | Application Number       | 16/788,498    |
|  | Filing Date              | 2/12/2020     |
|  | First Named Inventor     | Reed          |
|  | Examiner Name            | -- Unknown -- |
|  | Art Unit                 | -- Unknown -- |
|  | Attorney Docket No.      | TX1000-C12    |

| FOREIGN PATENT DOCUMENTS |                         |                                |  |   |
|--------------------------|-------------------------|--------------------------------|--|---|
| Examiner Initial         | Foreign Patent Document | Publication Date<br>MM-DD-YYYY | Name of Patentee or<br>Applicant of Cited Document | Pages, Columns, Lines, Where<br>Relevant Passages or Relevant<br>Figures Appear |
|                          | EP-1,374,481-B1         | 11-23-2005                     | Xanthos, et al.                                    |   |
|                          | WO 1999012228 A2        | 03-11-1999                     | Ameritec Corp.                                     |   |
|                          | EP 1 071 295 A2         | 01-24-2001                     | Phone.Com Inc.                                     |   |
|                          | JPH07-250381 A          | 09-26-1995                     | Fujitsu Ltd.                                       |   |
|                          | JP 2000-091982          | 03-31-2000                     | NEC Corp.  |   |
|                          | JPH11-027729 A          | 01-29-1999                     | Sanyo Electric Co.                                 |   |
|                          | WO 2000010296 A2        | 02-24-2000                     | SC-Wireless, Inc.                                  |   |
|                          | EP 1 126 376 A1         | 08-22-2001                     | NTT DoCoMo, Inc.                                   |   |
|                          | WO 2001076093 A1        | 10-11-2001                     | True-Position, Inc.                                |   |
|                          | WO 1990004293 A1        | 04-19-1990                     | Motorola, Inc.                                     |   |
|                          | GB 2 252 475 A          | 08-05-1992                     | Motorola, Inc.                                     |   |
|                          | WO 2000028756 A1        | 05-18-2000                     | Telefonaktiebolaget L M<br>Ericsson                |   |
|                          | GB 2 357 010 A          | 06-06-2001                     | Telefonaktiebolaget L M<br>Ericsson                |   |
|                          | EP 0 714 589 B1         | 05-06-2004                     | Borkowski, et al.                                  |   |
|                          | EP 1 028 543 A1         | 08-16-2000                     | Lucent Technologies Inc.                           |   |
|                          | WO 1995012268 A1        | 05-04-1995                     | Bellsouth Corporation                              |   |
|                          | WO 2001046710 A2        | 06-28-2001                     | Grid Data, Inc.                                    |   |
|                          | WO 2000040992 A1        | 07-13-2000                     | Trueposition, Inc.                                 |   |
|                          | WO 2000041402 A2        | 07-13-2000                     | Trueposition, Inc.                                 |   |
|                          | WO 2000077949 A1        | 12-21-2000                     | Time Domain Corporation                            |   |
|                          | WO 1998016077 A2        | 04-16-1998                     | Velazquez, et al.                                  |   |
|                          | WO 1994027398 A1        | 11-24-1994                     | Dennison, et al.                                   |   |
|                          | CA 2 325 644 A1         | 05-24-2001                     | Chiang, et al.                                     |   |
|                          | EP 0 705 046 A2         | 04-03-1996                     | Leblanc  |   |
|                          | JPH09287965A            | 11-04-1997                     | Matsushita Elec Ind Co Ltd.                        |   |
|                          | JP2000298429A           | 10-24-2000                     | Nippon Telegr & Teleph<br>Corp                     |   |
|                          | WO 1997024626 A2        | 07-10-1997                     | Micron Communications,<br>Inc.                     |   |
|                          | WO 1999027746 A1        | 06-03-1999                     | Ericsson Inc.                                      |   |
|                          | WO 1999052316 A1        | 10-14-1999                     | Nokia Telecommunications<br>Oy                     |   |
|                          | WO 2000067450 A1        | 11-09-2000                     | Digital Envoy, Inc.                                |   |
|                          | WO 2001048624 A1        | 07-05-2001                     | Glorikian  |   |
|                          | WO 2002005486 A2        | 01-17-2002                     | Invertix Corp.                                     |   |
|                          | WO 2002082843 A1        | 10-17-2002                     | Nokia Corp.  |   |
|                          | WO 2001019102 A1        | 03-15-2001                     | Nokia Mobile Phones Ltd.                           |   |

Examiner: /AJIT PATEL/

Date Considered: 05/18/2020

EXAMINER: Initial if reference considered, whether or not citation is in conformance with MPEP 609; Draw line through citation if not in conformance and not considered. Include copy of this form with next communication to applicant.

ALL REFERENCES CONSIDERED EXCEPT WHERE LINED THROUGH. /A.P/

|  |                          |               |
|--|--------------------------|---------------|
| Substitute for form 1449/PTO<br><br><b>INFORMATION DISCLOSURE<br/>STATEMENT BY APPLICANT</b> | <b>Complete if Known</b> |               |
|  | Application Number       | 16/788,498    |
|  | Filing Date              | 2/12/2020     |
|  | First Named Inventor     | Reed          |
|  | Examiner Name            | -- Unknown -- |
|  | Art Unit                 | -- Unknown -- |
|  | Attorney Docket No.      | TX1000-C12    |

| NON PATENT LITERATURE |   |
|-----------------------|---|
| Examiner Initial      | Include name of author (in CAPITAL LETTERS), title of the article (when appropriate), title of the item (book, magazine, journal, serial, symposium, catalog, etc.), date, page(s), volume-issue number(s), publisher, city and/or country where published. |
|                       | Notice of Allowance in 15/880,852 mailed on 07/31/2018, 69 pages (pp. 1-69 in pdf).   |
|                       | Office Action in 15/297,222 mailed on 12/14/2016, 23 pages (pp. 1-23 in pdf).   |
|                       | Notice of Allowance in 15/297,222 mailed on 01/12/2017, 6 pages (pp. 1-6 in pdf).   |
|                       | Office Action in 15/099,960 mailed on 06/28/2016, 15 pages (pp. 1-15 in pdf).   |
|                       | Notice of Allowance in 15/099,960 mailed on 11/29/2016, 38 pages (pp. 1-38 in pdf).   |
|                       | Office Action in 14/642,408 mailed on 08/10/2016, 21 pages (pp. 1-21 in pdf).   |
|                       | Notice of Allowance in 14/642,408 mailed on 09/28/2016, 6 pages (pp. 1-6 in pdf).   |
|                       | Office Action in 11/505,578 mailed on 07/07/2009, 7 pages (pp. 1-7 in pdf).   |
|                       | Office Action in 11/505,578 mailed on 05/12/2010, 4 pages (pp. 1-4 in pdf).   |
|                       | Final Office Action in 11/505,578 mailed on 11/09/2010, 6 pages (pp. 1-6 in pdf).   |
|                       | Office Action in 11/505,578 mailed on 08/18/2011, 7 pages (pp. 1-7 in pdf).   |
|                       | Office Action in 11/505,578 mailed on 03/28/2012, 7 pages (pp. 1-7 in pdf).   |
|                       | Final Office Action in 11/505,578 mailed on 12/12/2012, 8 pages (pp. 1-8 in pdf).   |
|                       | Notice of Allowance in 11/505,578 mailed on 05/06/2014, 13 pages (pp. 1-13 in pdf).   |
|                       | Office Action in 10/255,552, mailed on 08/10/05, 12 pages (pp. 1-12 in pdf).  |
|                       | Final Office Action 10/255,552, mailed on 03/07/06, 19 pages (pp. 1-19 in pdf).   |
|                       | LUI, et al., "Location Updates and Probabilistic Tracking Algorithms for Mobile Cellular Networks", Fourth International Symposium on Parallel Architectures, Algorithms, and Networks, June 1999, 6 pages (pp. 1-6 in pdf), US.                            |
|                       | KRISHNA, "Performance Issues in Mobile Wireless Networks", Office of Graduate Studies of Texas A&M University, August 1996, 204 pages (pp.1-204 in pdf), US.  |
|                       | ANONYMOUS, "LADOT'S ADAPTIVE TRAFFIC CONTROL SYSTEM (ATCS)", Presentation at the TRB Workshop on Adaptive Traffic Signal Control Systems, 9 January 2000  |
|                       | VUCETIC, et al. "Signal Monitoring System for Wireless Network Operation and Management", Dynamic Telecommunications, Inc., 0-7803-5030-8/98, 1998, pp. 296-300, IEEE   |
|                       | 3rd Generation Partnership Project: Technical Specification Group Radio Access Network: RRC Protocol Specification, 3GPP TS 25.331, V3.6.0 (2001-03), Release 1999, 2001, pp. 1-708, France   |
|                       | 3rd Generation Partnership Project: Technical Specification Group Services and System Aspects: Functional Stage 2 Description of LCS (Release 4), 3G TS 23.271, v 2.0.0 (2000-12) 2000, pps. 1-57, FR   |
|                       | BENNINGTON, et al. "Wireless Andrew: Experience Building a High Speed, Campus-Wide Wireless Data Network," MOBICOM 97, ACM 0-89791-988-2/97/9, 1997, pp. 55-65, Budapest, Hungary   |
|                       | ANHALT, et al., "Toward Context Aware Computing: Experiences and Lessons," IEEE Intelligent Systems, 1094-7167/01, May/June 2001, pp. 38-46. IEEE.  |
|                       | ECKHARDT, et al. "Measurement and Analysis of the Error Characteristics of an In-Building Wireless Network", Proceedings of SIGCOMM '96, Aug. 1996, pp. 1-12 (12 pages in pdf), Stanford, CA.   |
|                       | HE, et al., "WaveGuard: Secure Location Service for Wireless Andrew," Wireless 2001, 13th International Conference on Wireless Communications, Proceedings vol. 1, 9-11 July 2001, pp. 252-259, CA.   |

Examiner: /AJIT PATEL/

Date Considered: 05/18/2020

EXAMINER: Initial if reference considered, whether or not citation is in conformance with MPEP 609; Draw line through citation if not in conformance and not considered. Include copy of this form with next communication to applicant.

ALL REFERENCES CONSIDERED EXCEPT WHERE LINED THROUGH. /A.P/

|  |                          |               |
|--|--------------------------|---------------|
| Substitute for form 1449/PTO<br><br><b>INFORMATION DISCLOSURE<br/>STATEMENT BY APPLICANT</b> | <b>Complete if Known</b> |               |
|  | Application Number       | 16/788,498    |
|  | Filing Date              | 2/12/2020     |
|  | First Named Inventor     | Reed          |
|  | Examiner Name            | -- Unknown -- |
|  | Art Unit                 | -- Unknown -- |
|  | Attorney Docket No.      | TX1000-C12    |

| NON PATENT LITERATURE |  |
|-----------------------|--|
| Examiner Initial      | Include name of author (in CAPITAL LETTERS), title of the article (when appropriate), title of the item (book, magazine, journal, serial, symposium, catalog, etc.), date, page(s), volume-issue number(s), publisher, city and/or country where published.  |
|                       | HILLS, "Large-Scale Wireless LAN Design," IEEE Communications Magazine, 0163-6804/01, Nov 2001, pp. 98-104, IEEE.  |
|                       | HILLS, "Bringing Mobile Computing to a University Community of 10,000," IEEE Spectrum, 0018-9235/99, June 1999, pp. 49-53, IEEE.   |
|                       | HILLS, et al, "Seamless access to multiple wireless data networks; A Wireless Data Network Infrastructure at Carnegie Mellon University," IEEE Personal Communications, vol. 3, no. 1, 1070-9916/96, February 1996, pp. 56-63, IEEE  |
|                       | JOHNSON, et al., "Truly seamless wireless and mobile host networking; Protocols for Adaptive Wireless and Mobile Networking," IEEE Personal Communications, 1070-9916/96, February 1996, pp. 34-42, IEEE.  |
|                       | SMALL, et al., "Determining User Location for Context Aware Computing Through the Use of a Wireless LAN Infrastructure", 2000, 8 pages (pp. 1-8 in pdf), Institute for Complex Engineered Systems, Carnegie Mellon University, Pittsburgh, PA.   |
|                       | HASSAN, "Cellular Optimization", Cellular Business, September 1995, pp. 122-126  |
|                       | MILETIC, "Looking for Trouble", Wireless Review, 15 January 2001, pp. 52-54.   |
|                       | BISDIKIAN, et al., "Enabling Location-Based Applications", WMC 01, ACM 2001 1-58113-376-6/01/07, 2001, pp. 38-42, Rome, Italy.   |
|                       | ATENIESE, et al. "Untraceable Mobility or How to Travel Incognito", Computer Networks 31, 1389-1286/99, 1999, pp. 871-884, Elsevier Science B.V.   |
|                       | LEE, et al., "Enhanced privacy and authentication for the global system for mobile communications", Wireless Networks 5, 1999, pp. 231-243, Science Publishers, J.C. Baltzer.  |
|                       | BERA, et al., "Performance Analysis of Dynamic Location Updation Strategies for Mobile Users", Proc. Of 2000 International Conference on Distributed Computing Systems, April 2000, 8 pages (pp. 1-8 in pdf), Taiwan.  |
|                       | HEPSAYDIR, "Mobile Positioning in CDMA Cellular Networks", 38th IEEE Vehicular Technology Conference, 0-7803-5435-4/99, Feb 1999, pp. 795-799, IEEE.   |
|                       | XIE, et al., "Dynamic Location Area Management and Performance Analysis", IEEE, 0-7803-1266-x/93, 1993, pp. 536-539, IEEE.   |
|                       | LEONHARDT, et al. "Towards a general location service for mobile environments", Proceedings of Third International Workshop on Services in Distributed and Networked Environments, June 1996, 8 pages (pp. 1-8 in pdf), Macau.   |
|                       | Global System for Mobile Communications, "Digital cellular telecommunications system (Phase 2+); GSM Public Land Mobile Network (PLMN) access reference configuration" GSM 04.02 version 7.0.0 Release 1998, ETSI TS 100 551, V7.0.0, 1999, pp. 1-11, European Telecommunications Standards Institute, FR. |

Examiner: /AJIT PATEL/

Date Considered: 05/18/2020

EXAMINER: Initial if reference considered, whether or not citation is in conformance with MPEP 609; Draw line through citation if not in conformance and not considered. Include copy of this form with next communication to applicant.

ALL REFERENCES CONSIDERED EXCEPT WHERE LINED THROUGH. /A.P/



|  |                          |               |
|--|--------------------------|---------------|
| Substitute for form 1449/PTO<br><br><b>INFORMATION DISCLOSURE<br/>STATEMENT BY APPLICANT</b> | <b>Complete if Known</b> |               |
|  | Application Number       | 16/788,498    |
|  | Filing Date              | 2/12/2020     |
|  | First Named Inventor     | Reed          |
|  | Examiner Name            | -- Unknown -- |
|  | Art Unit                 | -- Unknown -- |
|  | Attorney Docket No.      | TX1000-C12    |

| NON PATENT LITERATURE |   |
|-----------------------|---|
| Examiner Initial      | Include name of author (in CAPITAL LETTERS), title of the article (when appropriate), title of the item (book, magazine, journal, serial, symposium, catalog, etc.), date, page(s), volume-issue number(s), publisher, city and/or country where published. |
|                       | 3rd Generation Partnership Project; Technical Specification Group Services and System Aspects; 3rd Generation mobile system Release 1999 Specifications (Release 1999), 3G TS 21.101, V3.1.0, 2000, pp. 1-14, FR.   |
|                       | 3rd Generation Partnership Project; Technical Specification Group Services and System Aspects; Location Services (LCS); Service description, Stage 1 (Release 4), 3 GPP TS 22.071, V4.3.0, 2001, pp. 1-40, FR.  |
|                       | 3rd Generation Partnership Project; Technical Specification Group Radio Access Networks; Base station conformance testing (FDD) (Release 1999), 3GPP TS 25.141, V3.5.0, 2001, pp. 1-103, FR.  |
|                       | 3rd Generation Partnership Project; Technical Specification Group Radio Access Network; Physical layer procedures (FDD) (Release 1999), 3GPP TS 25.214, V3.6.0, 2001, pp. 1-6, FR.  |
|                       | 3rd Generation Partnership Project; Technical Specification Group Radio Access Network; UE Procedures in Idle Mode and Procedures for Cell Reselection in Connected Mode (Release 1999), 3GPP TS 25.304, V3.6.0, 2001, pp. 1-41, FR.                        |
|                       | ACHARYA, et al., "Mobility Management in Wireless ATM Networks", IEEE Communications Magazine, 0163-6804/97, November 1997, pp. 100-109, IEEE.  |
|                       | AKYOL, et al., "Rerouting for Handoff in a Wireless ATM Network" IEEE Personal Communications, 1070-9916/96, October 1996, pp. 26-33, IEEE.   |
|                       | AKYOL, et al., "Handling Mobility in a Wireless ATM Network", IEEE, 0743-166X/96, 1996, pp. 1405-1413, IEEE.  |
|                       | LIU, et al., "Mobility Modeling, Location Tracking, and Trajectory Prediction in Wireless ATM Networks", IEEE Journal on Selected Areas in Communications, Vol. 16, No. 6, 0733-8716/98, August 1998, pp. 922-936, IEEE.                                    |
|                       | BALAKRISHNAN, et al., "Improving reliable transport and handoff performance in cellular wireless networks", Wireless Networks 1, 1995, pp. 469-481, J.C. Baltzer AG, Science Publishers.  |
|                       | AHONEN, et al., "Cellular network optimisation based on mobile location", IST-2000-25382-CELLO, Cellular Location Technology, Information Society Technologies, 2001, 51 pages (pp. 1-51 in pdf), Cello Consortium  |
|                       | RAYCHAUDHURI, et al., "WATMnet: A Prototype Wireless ATM System for Multimedia Personal Communication", IEEE Journal on Selected Areas in Communications, vol.15, no. 1, 0733-8716/97, January 1997, pp. 83-95, IEEE.                                       |
|                       | SMALL, "Location Determination in a Wireless LAN Infrastructure", Master's Thesis, Dept. of Electrical and Computer Engineering, 2000, pp. 1-37, Carnegie Mellon University   |
|                       | STEELE, et al., "Mobile Radio Communications; Second Edition; Second and Third Generation Cellular and WATM Systems", 1999, 20 pages (pp. 1-20 in pdf), John Wiley and Sons Ltd., England   |
|                       | International Telecommunication Union, "Specifications of Measuring Equipment; Basic Parameters for the Measurement of Error Performance at Bit Rates Below the Primary Rate", CCITT, Recommendation O.153, October 1992, 8 pages (pp. 1-8 in pdf), ITU.    |

Examiner: /AJIT PATEL/

Date Considered: 05/18/2020

EXAMINER: Initial if reference considered, whether or not citation is in conformance with MPEP 609; Draw line through citation if not in conformance and not considered. Include copy of this form with next communication to applicant.

ALL REFERENCES CONSIDERED EXCEPT WHERE LINED THROUGH. /A.P/

|  |                          |               |
|--|--------------------------|---------------|
| Substitute for form 1449/PTO<br><br><b>INFORMATION DISCLOSURE<br/>STATEMENT BY APPLICANT</b> | <b>Complete if Known</b> |               |
|  | Application Number       | 16/788,498    |
|  | Filing Date              | 2/12/2020     |
|  | First Named Inventor     | Reed          |
|  | Examiner Name            | -- Unknown -- |
|  | Art Unit                 | -- Unknown -- |
|  | Attorney Docket No.      | TX1000-C12    |

| NON PATENT LITERATURE |   |
|-----------------------|---|
| Examiner Initial      | Include name of author (in CAPITAL LETTERS), title of the article (when appropriate), title of the item (book, magazine, journal, serial, symposium, catalog, etc.), date, page(s), volume-issue number(s), publisher, city and/or country where published. |
|                       | VARSHNEY, et al., "Mobile Commerce: A New Frontier", Computer, 0018-9162/00, October 2000, pp. 32-38, IEEE  |
|                       | VEERARAGHAVAN, et al., "Mobility and Connection Management in a Wireless ATM Lane", IEEE Journal on Selected Areas in Communications, vol. 15, no. 1, 0733-8716/97, January 1997, pp. 50-68, IEEE.  |
|                       | YAMAMOTO, et al., "Position Location Technologies Using Signal Strength in Cellular Systems", VTC '01, 0-7803-6728-6/01, 2001, pp. 2570-2574, IEEE.   |
|                       | YU, et al., "Adaptive Resource Allocation for Prioritized Call Admission over an ATM-Based Wireless PCN", IEEE Journal on Selected Areas in Communications, vol. 15, no. 7, 0733-8716/97, September 1997, pp. 1208-1225, IEEE.                              |
|                       | YUAN, et al., "A signaling and control architecture for mobility support in wireless ATM networks", Mobile Networks and Applications 1, 1996, pp. 287-298, J.C. Baltzer AG, Science Publishers.   |
|                       | CHIASSON, et al., "Field Measurements of a Prototype Slow Frequency Hop Personal Communication System", 0-7803-2742-X/95, 1995, pp. 118-124, IEEE.  |
|                       | ERCEG, et al., "An Empirically Based Path Loss Model for Wireless Channels in Suburban Environments", IEEE Journal on Selected Areas in Communications, vol. 17, no. 1, 0733-8716/99, July 1999, pp. 1205-1211, IEEE.                                       |
|                       | FUJII, et al., "Experimental Research on Inter-Vehicle Communication using Infrared Rays", IEEE, 0-7803-3652-6/96, 1996, 6 pages (pp. 1-6 in pdf), IEEE.  |
|                       | KNEBELKAMP, et al., "Field Test of a CDMA System", IEEE, 0-7803-1927-3/94, 1994, pp. 1-5, IEEE  |
|                       | LI, et al., "Performance Evaluation of a Cellular Base Station Multibeam Antenna", IEEE Transactions on Vehicular Technology, vol. 46, no. 1, 0018-9545/97, February 1997, pp. 1-9, IEEE.   |
|                       | REED, et al., "An Overview of the Challenges and Progress in Meeting the E-911 Requirement for Location Service", IEEE Communications Magazine, 0163-6804/98, April 1998, pp. 30-37, IEEE.  |
|                       | REUDINK, "Cellular Network Design and Smart Antenna Systems", RAWCON'98 Proceedings, 0-7803-4988-1/98, 1998, pp. 19-22, IEEE.   |
|                       | XIA, et al., "Radio Propagation Characteristics for Line-of-Sight Microcellular and Personal Communications", IEEE Transactions on Antennas and Propagation, vol. 41, no. 10, 0018-926X/93, October 1993, pp. 1439-1447, IEEE.                              |
|                       | BATARIERE, et al., "Wideband MIMO Mobile Impulse Response Measurement at 3.7 GHz", VTC 2002, 0-7803-7484-3/02, 2002, pp. 26-30, IEEE.   |
|                       | BIN, et al., "Field test of HTS receivers on CDMA demonstration cluster in China", Chinese Science Bulletin, vol. 54, no. 4, Feb. 2009, pp. 612-615, Science in China Press, China.   |
|                       | HYNCICA, et al., "Urban Vehicle-to-Infrastructure Wireless Communications Range Evaluation", 15th International IEEE Conference on Intelligent Transportation Systems, 978-1-4673-3063-3/12, 16-19 September 2012, pp. 915-920, IEEE, US.                   |

Examiner: /AJIT PATEL/

Date Considered: 05/18/2020

EXAMINER: Initial if reference considered, whether or not citation is in conformance with MPEP 609; Draw line through citation if not in conformance and not considered. Include copy of this form with next communication to applicant.

ALL REFERENCES CONSIDERED EXCEPT WHERE LINED THROUGH. /A.P/

|  |                          |               |
|--|--------------------------|---------------|
| Substitute for form 1449/PTO<br><br><b>INFORMATION DISCLOSURE<br/>STATEMENT BY APPLICANT</b> | <b>Complete if Known</b> |               |
|  | Application Number       | 16/788,498    |
|  | Filing Date              | 2/12/2020     |
|  | First Named Inventor     | Reed          |
|  | Examiner Name            | -- Unknown -- |
|  | Art Unit                 | -- Unknown -- |
|  | Attorney Docket No.      | TX1000-C12    |

| NON PATENT LITERATURE |   |
|-----------------------|---|
| Examiner Initial      | Include name of author (in CAPITAL LETTERS), title of the article (when appropriate), title of the item (book, magazine, journal, serial, symposium, catalog, etc.), date, page(s), volume-issue number(s), publisher, city and/or country where published.           |
|                       | IMPERATORE, et al., "Path Loss Measurements at 3.5 GHz: A Trial Test WiMax Based in Rural Environment", IEEE Tridentcom 2007, May 2007, 8 pages (pp. 1-8 in pdf), US  |
|                       | NILSSON, et al., "Multipath Propagation Simulator for V2X Communication Tests on Cars; Design Aspects and Feasibility Experiments", 7 <sup>th</sup> European Conference on Antennas and Propagation (EuCAP), 978-88-907018-3-2/13, 2013, pp. 1342-1346, IEEE.         |
|                       | RIBLETT, et al., "Findings on the Suitability of 802.11 for Highly Mobile Broadband Networks", 978-1-4244-5239-2/09, 2009, pp. 1-7, IEEE.   |
|                       | SCHAFFNER, et al., "A Drive Test Measurement Approach to Characterize On-Vehicle 2x2 LTE-MIMO Antennas", 978-1-4673-5692-3/13, 2013, pp. 85-88, IEEE.   |
|                       | SCHUMACHER, et al., "Vehicle-to-Vehicle IEEE 802.11p Performance Measurements at Urban Intersections", Intelligent Vehicular Networking: V2V/V2I Communications and Applications, 978-1-4577-2053-6/12, 2012, pp. 7131-7135, IEEE.                                    |
|                       | TAO, et al., "An Overview of Cooperative Communications", LTE-Advanced and 4G Wireless Communications: Part 2, IEEE Communications Magazine, 0163-6804/12, June 2012, pp. 65-71, IEEE.  |
|                       | XIA, et al., "Field Operational Testing of ECO-Approach Technology at a Fixed-Time Signalized Intersection", 15 <sup>th</sup> International IEEE Conference on Intelligent Transportation Systems, 978-1-4673-3063-3/12, 16-19 September 2012, pp. 188-193, IEEE, US. |
|                       | ZHANG, et al., "Application of Drive Test for QoS Evaluation in 3G Wireless Networks", Proceedings of ICCT 2003, 2003, pp. 1206-1209.   |
|                       | KUBBAR, et al., "Multiple Access Control Protocols for Wireless ATM: Problems Definition and Design Objectives", IEEE Communications Magazine, 0163-6804/97, November 1997, pp. 93-99, IEEE.  |
|                       | NAYLON, et al., "Low-Latency Handover in a Wireless ATM LAN", IEEE Journal on Selected Areas in Communications, vol. 16, no. 6, 0733-8716/98, August 1998, pp. 909-921, IEEE.   |
|                       | RAMASWAMY, et al., "PCS Network Survivability", IEEE, 0-7803-5668-3/99, 1999, pp. 1028-1032, IEEE.  |
|                       | HARTER, et al., "A Distributed Location System for the Active Office", IEEE Network, 0890-8044/94, January/February 1994, pp. 62-70, IEEE.  |
|                       | Notice of Allowance in 15/468,265 mailed on 11/21/2017, 43 pages (pp.1-43 in pdf).  |
|                       | Notice of Allowance in 15/717,138 mailed on 12/13/2017, 21 pages (pp.1-21 in pdf).  |
|                       | TRAXCELL TECHNOLOGIES, LLC, "List of Pending Traxcell Litigation as of 06-28-2018", 06/28/2018, 1 page in pdf.  |
|                       | Office Action in 15/880,852 mailed on 10/29/2018, 7 pages (pp. 1-7 in pdf).   |
|                       | 3rd Generation Partnership Project; Technical Specification Group Radio Access Network; UTRAN Iub Interface NBAP Signalling (Release 4), 3GPP TS 25.433, V4.0.0, 2001-03, 2001, pp. 1-539, FR.  |
|                       | HOLMA, et al., "WCDMA for UMTS: Radio Access for Third Generation Mobile Communications", 2000, 74 pages (pp. 1-74 in pdf), John Wiley & Sons, Ltd., England.   |
|                       | PRASAD, et al., "An Overview of CDMA Evolution Toward Wideband CDMA", IEEE Communications Surveys, Fourth Quarter 1998, vol. 1, no. 1, 28 pages (pp. 1-28 in pdf), IEEE Communications Society, US  |

Examiner: /AJIT PATEL/

Date Considered: 05/18/2020

EXAMINER: Initial if reference considered, whether or not citation is in conformance with MPEP 609; Draw line through citation if not in conformance and not considered. Include copy of this form with next communication to applicant.

ALL REFERENCES CONSIDERED EXCEPT WHERE LINED THROUGH. /A.P/

|  |                          |               |
|--|--------------------------|---------------|
| Substitute for form 1449/PTO<br><br><b>INFORMATION DISCLOSURE<br/>STATEMENT BY APPLICANT</b> | <b>Complete if Known</b> |               |
|  | Application Number       | 16/788,498    |
|  | Filing Date              | 2/12/2020     |
|  | First Named Inventor     | Reed          |
|  | Examiner Name            | -- Unknown -- |
|  | Art Unit                 | -- Unknown -- |
|  | Attorney Docket No.      | TX1000-C12    |

| NON PATENT LITERATURE |   |
|-----------------------|---|
| Examiner Initial      | Include name of author (in CAPITAL LETTERS), title of the article (when appropriate), title of the item (book, magazine, journal, serial, symposium, catalog, etc.), date, page(s), volume-issue number(s), publisher, city and/or country where published. |
|                       | ANDERSSON, "GPRS and 3G Wireless Applications: The Ultimate Guide to Maximizing Mobile Internet Technologies", Professional Developer's Guide Series, 2001, 23 pages (pp. 1-23 in pdf), John Wiley & Sons, Inc., US.  |
|                       | OJANPERA, et al., "An Overview of Third-Generation Wireless Personal Communications: A European Perspective", IEEE Personal Communications, December 1998, pp. 59-65, IEEE, US.   |
|                       | 3rd Generation Partnership Project; Technical Specification Group Radio Access Network; Physical layer - Measurements (FDD) (Release 1999), 3GPP TS 25.215, V3.5.0, 2000-12, 2000, pp. 1-17, FR.  |
|                       | 3rd Generation Partnership Project; Technical Specification Group Radio Access Networks; Requirements for Support of Radio Resource Management (FDD) (Release 1999), 3GPP TS 25.133, V3.3.0, 2000-09, 2000, pp. 1-92, FR.                                   |
|                       | OETTING, "Cellular Mobile Radio - An Emerging Technology", IEEE Communications Magazine, November 1983, pp. 10-15, vol. 21, iss. 8, IEEE, US.   |
|                       | RAHNEMA, "Overview of the GSM System and Protocol Architecture", IEEE Communications Magazine, April 1993, pp. 92-100, vol. 31, iss. 4, IEEE, US.   |
|                       | LEE, "Overview of Cellular CDMA", IEEE Transactions on Vehicular Technology, May 1991, pp. 291-302, vol. 40, no. 2, IEEE, US.   |
|                       | PANDYA, "Emerging Mobile and Personal Communication Systems", IEEE Communications Magazine, June 1995, pp. 44-52, vol. 33, iss. 6, IEEE, US.  |
|                       | BLECHER, "Advanced Mobile Phone Service", IEEE Transactions on Vehicular Technology, May 1980, pp. 238-244, vol. VT-29, no. 2, IEEE, US   |
|                       | SHUKLA, et al., "Comparative Study of 1G, 2G, 3G and 4G", Journal of Engineering, Computers & Applied Sciences, April 2013, pp. 55-63, vol. 2, no. 4, Blue Ocean Research Journals, IN.   |
|                       | MUNOZ-RODRIGUEZ, et al., "Multiple Criteria for Hand-off in Cellular Mobile Radio" IEE Proceedings, February 1987, pp. 85-88, vol. 134, pt. F, no. 1, IEE.  |
|                       | CHIANI, et al., "Partial Compensation Signal-Level-Based Up-Link Power Control to Extend Terminal Battery Duration", IEEE Transactions on Vehicular Technology, July 2001, pp. 1125-1131, vol. 50, no. 4, IEEE, US.   |
|                       | SWEET, "Cell phones answer Internet's call", IEEE Spectrum, August 2000, pp. 42-46, vol. 37, iss. 8, IEEE, US   |
|                       | VAN DER VEEN, "Revised Draft Report of the 10 <sup>th</sup> TSG-RAN meeting (Bangkok, Thailand, 6-8 December 2000)", TSG-RAN meeting #11, RP-010003, March 2001, pp. 1-56, 3GGG support team, Palm Springs, CA.   |
|                       | VAN DER VEEN, "Revised Draft Report of the 9 <sup>th</sup> TSG-RAN meeting (Oahu, HI, USA, 20-22 September 2000)", TSG-RAN meeting #10, RP-000522, December 2000, pp. 1-58, 3GGG support team, Bangkok, Thailand.   |
|                       | VAN DER VEEN, "Approved Report of the 11 <sup>th</sup> TSG-RAN meeting (Palm Springs, CA, USA, 13-16 March 2001)", TSG-RAN meeting #12, RP-010283, June 2001, pp. 1-78, 3GGG support team, Stockholm, Sweden.   |

Examiner: /AJIT PATEL/

Date Considered: 05/18/2020

EXAMINER: Initial if reference considered, whether or not citation is in conformance with MPEP 609; Draw line through citation if not in conformance and not considered. Include copy of this form with next communication to applicant.

ALL REFERENCES CONSIDERED EXCEPT WHERE LINED THROUGH. /A.P/

|  |                          |               |
|--|--------------------------|---------------|
| Substitute for form 1449/PTO<br><br><b>INFORMATION DISCLOSURE<br/>STATEMENT BY APPLICANT</b> | <b>Complete if Known</b> |               |
|  | Application Number       | 16/788,498    |
|  | Filing Date              | 2/12/2020     |
|  | First Named Inventor     | Reed          |
|  | Examiner Name            | -- Unknown -- |
|  | Art Unit                 | -- Unknown -- |
|  | Attorney Docket No.      | TX1000-C12    |

| NON PATENT LITERATURE |   |
|-----------------------|---|
| Examiner Initial      | Include name of author (in CAPITAL LETTERS), title of the article (when appropriate), title of the item (book, magazine, journal, serial, symposium, catalog, etc.), date, page(s), volume-issue number(s), publisher, city and/or country where published.   |
|                       | BELLER, et al., "Privacy and Authentication on a Portable Communications System", IEEE Journal on Selected Areas in Communications, August 1993, pp. 821-829, vol. 11, no. 6, IEEE, US.   |
|                       | PERUGINI, "Anytime, Anywhere: The Social Impact of Emerging Communication Technology", IEEE Transactions on Professional Communication, March 1996, pp. 4-15, vol. 39, no. 1, IEEE, US.   |
|                       | KAARANEN, et al., "UMTS Networks: Architecture, Mobility and Services", 2001, pp. 154 and 287, John Wiley & Sons, Ltd., England.  |
|                       | 3rd Generation Partnership Project, Universal Mobile Telecommunications System (UMTS); Functional stage 2 description of location services (3GPP TS 23.271, V4.1.0, 2001, Release 4), ETSI TS 123 271, 2001, pp. 1-71, ETSI, FR.  |
|                       | Claim Construction Memorandum Opinion and Order, Traxcell Techs, LLC vs. Huawei Techs. USA, E. D. Tex., Case 2:17-cv-00042-RWS-RSP, Document 261, 07 January 2019, pp. 1-34.  |
|                       | Claim Construction Memorandum Opinion and Order, Traxcell Techs, LLC vs. AT&T, Inc., E. D. Tex., Case 2:17-cv-00718-RWS-RSP, Document 171, 15 April 2019, pp. 1-58.   |
|                       | Report on the Filing Or Determination of an Action Regarding a Patent or Trademark, Traxcell Technologies, LLC vs. ALE USA Inc., d/b/a Alcatel-Lucent Enterprise USA Inc., USA, E.D. Tex., Case 2:17-cv-00041-RWS-RSP, Document 3, 18 Jan 2017, 1 page.   |
|                       | Report on the Filing Or Determination of an Action Regarding a Patent or Trademark, Traxcell Technologies, LLC vs. AT&T, Inc., AT&T Corporation, and AT&T Mobility LLC, USA, E.D. Tex., Case 2:17-cv-00718-RWS-RSP, Document 3, 31 October 2017, 1 page.  |
|                       | Report on the Filing Or Determination of an Action Regarding a Patent or Trademark, Traxcell Technologies, LLC vs. Huawei Technologies USA Inc., USA, E.D. Tex., Case 2:17-cv-00042-RWS-RSP, Document 3, 18 Jan 2017, 1 page.   |
|                       | Report on the Filing Or Determination of an Action Regarding a Patent or Trademark, Traxcell Technologies, LLC vs. Motorola Solutions, Inc., USA, E.D. Tex., Case 2:17-cv-00043-RWS-RSP, Document 3, 18 Jan 2017, 1 page.   |
|                       | Report on the Filing Or Determination of an Action Regarding a Patent or Trademark, Traxcell Technologies, LLC vs. Nokia Solutions and Networks Oy., USA, E.D. Tex., Case 2:17-cv-00044-RWS-RSP, Document 3, 18 Jan 2017, 1 page.   |
|                       | Report on the Filing Or Determination of an Action Regarding a Patent or Trademark, Traxcell Technologies, LLC vs. Samsung Electronics America, Inc., USA, E.D. Tex., Case 2:17-cv-00045-RWS-RSP, Document 35-1, 29 Jan 2018, 1 page.   |
|                       | Report on the Filing Or Determination of an Action Regarding a Patent or Trademark, Traxcell Technologies, LLC vs. Sprint Communications Company, LP, Sprint Corporation, Sprint Spectrum, LP, and Spring Solutions, Inc., USA, E.D. Tex., Case 2:17-cv-00719-RWS-RSP, Document 2, 31 October 2017, 1 page. |

Examiner: /AJIT PATEL/

Date Considered: 05/18/2020

EXAMINER: Initial if reference considered, whether or not citation is in conformance with MPEP 609; Draw line through citation if not in conformance and not considered. Include copy of this form with next communication to applicant.

ALL REFERENCES CONSIDERED EXCEPT WHERE LINED THROUGH. /A.P/

|  |                          |               |
|--|--------------------------|---------------|
| Substitute for form 1449/PTO<br><br><b>INFORMATION DISCLOSURE<br/>STATEMENT BY APPLICANT</b> | <b>Complete if Known</b> |               |
|  | Application Number       | 16/788,498    |
|  | Filing Date              | 2/12/2020     |
|  | First Named Inventor     | Reed          |
|  | Examiner Name            | -- Unknown -- |
|  | Art Unit                 | -- Unknown -- |
|  | Attorney Docket No.      | TX1000-C12    |

| NON PATENT LITERATURE |   |
|-----------------------|---|
| Examiner Initial      | Include name of author (in CAPITAL LETTERS), title of the article (when appropriate), title of the item (book, magazine, journal, serial, symposium, catalog, etc.), date, page(s), volume-issue number(s), publisher, city and/or country where published.                         |
|                       | Report on the Filing Or Determination of an Action Regarding a Patent or Trademark, Traxcell Technologies, LLC vs. T-Mobile, USA, Inc., USA, E.D. Tex., Case 2:17-cv-00720-RWS-RSP, Document 2, 31 October 2017, 1 page.  |
|                       | Report on the Filing Or Determination of an Action Regarding a Patent or Trademark, Traxcell Technologies, LLC vs. Verizon Communications, Inc., and Verizon Wireless Personal Communications, LP, USA, E.D. Tex., Case 2:17-cv-00721-RWS-RSP, Document 2, 31 October 2017, 1 page. |
|                       | Report and Recommendation, Traxcell Techs, LLC vs. Huawei Techs. USA, Nokia Solutions and Networks Oy, et al., E. D. Tex., Case 2:17-cv-00042-RWS-RSP, Document 386, 15 May 2019, pp. 1-16.   |
|                       | CHAKRABORTY, "A Distributed Architecture for Mobile, Location-Dependent Applications", S.B., Computer Science and Engineering, Massachusetts Institute of Tech, May 2000, pp. 1-58, US.   |
|                       | GARMASH, "A Geographic XML-based Format for the Mobile Environment", Proceedings of the 34 <sup>th</sup> Annual Hawaii International Conference on System Sciences, January 2001, pp. 1-9, IEEE, US.  |
|                       | WILLASSEN, "A method for implementing Mobile Station Location in GSM" 3 December 1998, 74 pages (pp. 1-74 in pdf).  |
|                       | LEONHARDI, et al., "An architecture for a distributed universal location service", Institute of Parallel and Distributed High-Performance Systems, October 1996, 6 pages (pp. 1-6 in pdf), Germany.   |
|                       | HAN, et al., "An Efficient Location Cache Scheme for Hierarchical Database Architecture in PCS Networks", 15 <sup>th</sup> International Parallel and Distributed Processing Symposium, April 2000, 9 pages (pp. 1-9 in pdf), IEEE, San Francisco, US.                              |
|                       | Benefon Oyj, "BENEFON ESC! Owner's Manual", Publication number YZ2400-1, 2001, 169 pages (pp.1-169 in pdf).   |
|                       | Benefon Oyj, "BENEFON ESC! Owner's Manual", Publication number YZ2400-4*, 2002, 169 pages (pp.1-169 in pdf).  |
|                       | Cambridge Positioning Systems Ltd., "CURSOR: Technical Details", 1997, 2 pages (pp. 1-2 in pdf).  |
|                       | Cellular Networking Perspectives LTD, Cellular Networking Perspectives, Vol. 8, No. 11, November 1999, 6 pages (pp.1-6 in pdf).   |
|                       | MADRIA, et al., "Data Organization Issues for Location-dependent Queries in Mobile Computing", CSD TR #99-038, November 1999, 18 pages (pp. 1-18 in pdf), Purdue University   |
|                       | LAITINEN, et al., "Database Correlation Method for GSM Location", IEEE VTS 53 <sup>rd</sup> Vehicular Tech Conference, May 2001, 6 pages (pp.1-6 in pdf), IEEE, Greece.   |
|                       | SAVVIDES, et al., "Dynamic Fine-Grained Localization in Ad-Hoc Wireless Sensor Networks", May 2001, pp. 166-179, University of CA.  |
|                       | MARKKULA, Jouni, "Dynamic Geographic Personal Data - New Opportunity and Challenge Introduced by the Location-Aware Mobile Networks", Cluster Computing, 4, 2001, pp. 369-377, Kluwer Academic Publishers, The Netherlands.   |
|                       | WANG, et al., "E-911 Location Standards and Location Commercial Services", 2000 IEEE Emerging Technologies Symposium: Broadband, Wireless Internet Access, April 2000, 6 pages (pp. 1-6 in pdf), IEEE, TX, US   |

Examiner: /AJIT PATEL/

Date Considered: 05/18/2020

EXAMINER: Initial if reference considered, whether or not citation is in conformance with MPEP 609; Draw line through citation if not in conformance and not considered. Include copy of this form with next communication to applicant.

ALL REFERENCES CONSIDERED EXCEPT WHERE LINED THROUGH. /A.P/

|  |                          |               |
|--|--------------------------|---------------|
| Substitute for form 1449/PTO<br><br><b>INFORMATION DISCLOSURE<br/>STATEMENT BY APPLICANT</b> | <b>Complete if Known</b> |               |
|  | Application Number       | 16/788,498    |
|  | Filing Date              | 2/12/2020     |
|  | First Named Inventor     | Reed          |
|  | Examiner Name            | -- Unknown -- |
|  | Art Unit                 | -- Unknown -- |
|  | Attorney Docket No.      | TX1000-C12    |

| NON PATENT LITERATURE |   |
|-----------------------|---|
| Examiner Initial      | Include name of author (in CAPITAL LETTERS), title of the article (when appropriate), title of the item (book, magazine, journal, serial, symposium, catalog, etc.), date, page(s), volume-issue number(s), publisher, city and/or country where published.   |
|                       | ETSI, European Digital Cellular Telecommunications System (Phase 2); Location Registration Procedures (GSM 03.12), ETS 300 530, September 1994, pp. 1-11, ETSI, FR.   |
|                       | ETSI, Digital Cellular Telecommunications System; Location Registration Procedures (GSM 03.12), v. 5.0.0., Nov 1996, pp. 1-11, ETSI, FR.  |
|                       | ETSI, "Digital Cellular Telecommunications System (Phase 2+); Location Services (LCS); (Functional Description) - Stage 2 (GSM 03.71 Version 8.0.0 Release 1999)", ETSI TS 101 724, V8.0.0 (2000-10), 2000, pp. 1-107, ETSI, FR.  |
|                       | DJUKNIC, et al., "Geolocation and Assisted GPS", Computer, vol. 34, issue 2, February 2001, pp. 123-125, IEEE, US.  |
|                       | "Global System for Mobile Communication Technology: Mobile Device Investigations Program", Technical Operations Division, DHS-FLETC.  |
|                       | "Global System for Mobile Communication (GSM)" The International Engineering Consortium, pp.1-19.   |
|                       | DRANE, et al., "Positioning GSM Telephones", IEEE Communications Magazine, April 1998, pp. 46-59, IEEE, US.   |
|                       | PANAGIOTAKIS, et al., "Integrated Generic Architecture for Flexible Service Provision to Mobile Users", Proceedings of 12 <sup>th</sup> IEEE International Symposium on Personal, Indoor and Mobile Radio Communications, 30 September - 3 October 2001, IEEE, US.  |
|                       | BISWAS, et al., "Leveraging Location-Based Services for Mobile Applications", June 2001, 19 pages (pp. 1-19 in pdf), Oracle Corp., US.  |
|                       | JANA, et al., "Location Based Services in a Wireless WAN Using Cellular Digital Packet Data (CDPD)", MobiDe'01 Proceedings of the 2 <sup>nd</sup> ACM International Workshop on Data Engineering for Wireless and Mobile Access, 2001, pp. 74-80, Santa Barbara, CA, US   |
|                       | LEONHARDT, et al., "Location Service In Mobile Computing Environments", Comput. & Graphics, vol. 20, no. 5, 1996, pp. 627-632, Elsevier Science Ltd, GB.  |
|                       | STEER, et al., "Location Services Architecture for Future Mobile Networks", VTC2000-Spring, 2000 IEEE 51 <sup>st</sup> Vehicular Technology Conference Proceedings, May 2000, IEEE, Japan.  |
|                       | KOPPEL, Ian, "Location Services Are Here—Now", ArcUser Online, April-June 2001, 3 pages (pp. 1-3 in pdf), Esri, US.   |
|                       | "PHONE.COM: Phone.Com And Snaptrack Team To Provide High-Performance Wireless Location Solutions For Mobile E-Commerce & Value- Added Location Services; Effort To Result In Wireless Assisted GPS-Based Products For Global Location Market", M2 Presswire; Coventry, Sept 2000, 5 pages (pp.1-5 in pdf), Normans Media Ltd, UK. |

Examiner: /AJIT PATEL/

Date Considered: 05/18/2020

EXAMINER: Initial if reference considered, whether or not citation is in conformance with MPEP 609; Draw line through citation if not in conformance and not considered. Include copy of this form with next communication to applicant.

ALL REFERENCES CONSIDERED EXCEPT WHERE LINED THROUGH. /A.P/

|  |                          |               |
|--|--------------------------|---------------|
| Substitute for form 1449/PTO<br><br><b>INFORMATION DISCLOSURE<br/>STATEMENT BY APPLICANT</b> | <b>Complete if Known</b> |               |
|  | Application Number       | 16/788,498    |
|  | Filing Date              | 2/12/2020     |
|  | First Named Inventor     | Reed          |
|  | Examiner Name            | -- Unknown -- |
|  | Art Unit                 | -- Unknown -- |
|  | Attorney Docket No.      | TX1000-C12    |

| NON PATENT LITERATURE |  |
|-----------------------|--|
| Examiner Initial      | Include name of author (in CAPITAL LETTERS), title of the article (when appropriate), title of the item (book, magazine, journal, serial, symposium, catalog, etc.), date, page(s), volume-issue number(s), publisher, city and/or country where published.  |
|                       | "Webraska: Phone.Com And Webraska Partner To Equip Wireless Software Developers With Mapping And Routing Function Capabilities; Wireless Internet Pioneers Launch Development Tools For Enhanced Location- Based Applications", M2 Presswire; Coventry, July 2000, 4 pages (pp. 1-4 in pdf), Normans Media Ltd., UK. |
|                       | ZAGAMI, et al., "Providing Universal Location Services Using a Wireless E911 Location Network", IEEE Communications Magazine, April 1998, pp. 66-71, IEEE, US.   |
|                       | JOSE, et al., "Scalable and Flexible Location-Based Services for Ubiquitous Information Access", HUC 1999, International Symposium on Handheld and Ubiquitous Computing, 1999, pp. 52-66, Springer-Verlag, DE.   |
|                       | KESDOGAN, et al., "Secure Location Information Management In Cellular Radio Systems", IEEE Wireless Communication System Symposium, Nov 1995, pp. 35-40, IEEE, US.   |
|                       | ETSI, "Changes to LCS for MO position", Technical Specification Group Services and System Aspects, TSGS#5(99)437, Meeting #5, Kyongju, Korea, October 1999, 40 pages (pp. 1-40 in pdf), ETSI.  |
|                       | US Wireless Corp., "Televigation Partners with U.S. Wireless to Power Real-Time Navigation Application for Mobile Phones", Business Wire, Aug 2000, 3 pages (pp. 1-3 in pdf), US   |
|                       | Bloor Research, "The Bloor Perspective: Life after ASP, diversified Oracle and looking for location-based services", ZDNet, July 2001 2 pages (pp. 1-2 in pdf).  |
|                       | U.S. Dept of Transportation, "Trav-Tek System Architecture Evaluation" Research and Development Turner-Fairbank Highway Research Center, pub. no. FHWA-RD-94-141, July 1995, 156 pages (pp. 1-156 in pdf), US.   |
|                       | ETSI, "Universal Mobile Telecommunications System (UMTS); Location Services (LCS); Functional description; Stage 2 (UMTS), (3GPP TS 23.171 version 3.10.0 Release 1999)", ETSI TS 123 171, v3.10.0 (2003-06), 53 pages (pp. 1-53 in pdf), ETSI, FR.  |
|                       | TURNER, et al., "Travel Time Data Collection Handbook Report No. FHWA-PL-98-035", March 1998, 341 pages (pp. 1-341 in pdf), Texas Transportation Institute, Federal Highway Administration, US.  |
|                       | "Webraska: Orange Switzerland Selects Webraska's Enabling Technology And Know-How To Launch Europe's First Location-Based WAP Navigation Services With Automatic Positioning And Wireless Navigation", M2 Presswire; Coventry, December 2000, 4 pages (pp. 1-4 in pdf), Normans Media Ltd, UK.                       |
|                       | Garmin, "NavTalk Cellular Phone / GPS Receiver", Garmin, 1999, 128 pages (pp.1-128 in pdf), Garmin Corp., US.  |
|                       | Notice of Allowance in 15/880,852 mailed on 06/24/2019, 14 pages (pp. 1-14 in pdf).  |

Examiner: /AJIT PATEL/

Date Considered: 05/18/2020

EXAMINER: Initial if reference considered, whether or not citation is in conformance with MPEP 609; Draw line through citation if not in conformance and not considered. Include copy of this form with next communication to applicant.

-----  
ALL REFERENCES CONSIDERED EXCEPT WHERE LINED THROUGH. /A.P/



|  |                          |               |
|--|--------------------------|---------------|
| Substitute for form 1449/PTO<br><br><b>INFORMATION DISCLOSURE<br/>STATEMENT BY APPLICANT</b> | <b>Complete if Known</b> |               |
|  | Application Number       | 16/788,498    |
|  | Filing Date              | 2/12/2020     |
|  | First Named Inventor     | Reed          |
|  | Examiner Name            | -- Unknown -- |
|  | Art Unit                 | -- Unknown -- |
|  | Attorney Docket No.      | TX1000-C12    |

| NON PATENT LITERATURE |  |
|-----------------------|--|
| Examiner Initial      | Include name of author (in CAPITAL LETTERS), title of the article (when appropriate), title of the item (book, magazine, journal, serial, symposium, catalog, etc.), date, page(s), volume-issue number(s), publisher, city and/or country where published.  |
|                       | Global System for Mobile Communications, "Digital cellular telecommunications system (Phase 2+); General Packet Radio Service (GPRS); Service Description; Stage 2" GSM 03.60 version 7.4.1 Release 1998, ETSI EN 301 344, V7.4.1 (2000-09), 2000, pp. 1-117, European Telecommunications Standards Institute, FR. |
|                       | LAITINEN, et al., "Cellular network optimisation based on mobile location", Cellular Location Technology: CELLO-WP2-VTT-D03-007-Int., 2001, 51 pages (pp. 1-51 in pdf), Cello Consortium.  |
|                       | Federal Communications Commission, "In the Matter of Revision of the Commission's Rules, CC Docket No. 94-102 To Ensure Compatibility with RM-8143 Enhanced 911 Emergency Calling Systems; Report and Order and Further Notice of Proposed Rulemaking", July 1996, pp. 1-48, US.                                   |
|                       | Federal Trade Commission, "The Mobile Wireless Web, Data Services and Beyond: Emerging Technologies and Consumer Issues", 1 page, Federal Trade Commission, US.  |
|                       | MILLER, "IN RE HE MOBILE WIRELESS WEB, DATA SERVICES AND BEYOND: EMERGING TECHNOLOGY AND COMSUMER ISSUES, A Public Workshop, RESPONSE STATEMENT FOR DAY II PANEL: Building Privacy and Security Solutions into the Technological Architecture", December 2000, pp. 1-12, Federal Trade Commission, US.             |
|                       | Federal Trade Commission, Agenda for "The Mobile Wireless Web, Data Services and Beyond: Emerging Technologies and Consumer Issues", December 2000, pp. 1-3, Federal Trade Commission, US.   |
|                       | Federal Trade Commission, Conference Proceedings for "The Mobile Wireless Web, Data Services and Beyond: Emerging Technologies and Consumer Issues", December 2000, pp. 1-59, vol. 1, Federal Trade Commission, US.  |
|                       | Federal Trade Commission, Conference Proceedings for "The Mobile Wireless Web, Data Services and Beyond: Emerging Technologies and Consumer Issues", December 2000, pp. 1-97, vol. 2, Federal Trade Commission, US.  |
|                       | ASCHE, "The Omega System of Global Navigation", 10 <sup>th</sup> International Hydrographic Conference, April 1972, pp. 87-99, US.   |
|                       | KERNIGHAN, et al., "The C Programming Language", 2 <sup>nd</sup> edition, AT&T Laboratories, 1988, 288 pages (pp. 1-288 in pdf), Prentice Hall, US.  |
|                       | RAPPAPORT, "Wireless Communications: Principles & Practice" 2002, 639 pages (pp. 1-639 in pdf), 2 <sup>nd</sup> edition, Prentice-Hall Inc., US.   |
|                       | ETSI, "Release Note: Recommendation GSM 06.10; GSM Full Rate Speech Transcoding; GSM full rate speech transcoding", February 1992, 95 pages (pp. 1-95 in pdf), v. 3.2.0, ETSI, FR.   |
|                       | Notice of Allowance in 16/116,215 mailed on 08/22/2019, 64 pages (pp. 1-64 in pdf).  |
|                       |  |
|                       |  |
|                       |  |
|                       |  |

Examiner: /AJIT PATEL/

Date Considered: 05/18/2020

EXAMINER: Initial if reference considered, whether or not citation is in conformance with MPEP 609; Draw line through citation if not in conformance and not considered. Include copy of this form with next communication to applicant.

ALL REFERENCES CONSIDERED EXCEPT WHERE LINED THROUGH. /A.P/

## Bibliographic Data

Application No: 16/788,498

Foreign Priority claimed:  Yes  No

35 USC 119 (a-d) conditions met:  Yes  No  Met After Allowance

Verified and Acknowledged: /AJIT PATEL/

Examiner's Signature

Initials

Title:

MOBILE WIRELESS DEVICE PROVIDING OFF-LINE AND ON-LINE GEOGRAPHIC NAVIGATION INFORMATION

| FILING or 371(c) DATE | CLASS | GROUP ART UNIT | ATTORNEY DOCKET NO. |
|-----------------------|-------|----------------|---------------------|
| 02/12/2020            | 455   | 2416           | TX1000-C12          |
| <b>RULE</b>           |       |                |                     |

### APPLICANTS

Traxcell Technologies, LLC, Plano, TX,

### INVENTORS

Mark Jefferson Reed Tucson, AZ, UNITED STATES

Stephen Michael Palik Redondo Beach, CA, UNITED STATES

### CONTINUING DATA

This application is a CON of 16557277 08/30/2019

16557277 is a CON of 16116215 08/29/2018 PAT 10448209

16116215 is a CON of 15880852 01/26/2018 PAT 10390175

15880852 is a CON of 15717138 09/27/2017 PAT 9918196

15717138 is a CON of 15468265 03/24/2017 PAT 9888353

15468265 is a CON of 15297222 10/19/2016 PAT 9642024

15297222 is a CON of 14642408 03/09/2015 PAT 9510320

14642408 is a CON of 11505578 08/17/2006 PAT 8977284

11505578 is a CIP of 10255552 09/24/2002ABN

10255552 has PRO of 60391469 06/26/2002

10255552 has PRO of 60383528 05/28/2002

10255552 has PRO of 60383529 05/28/2002

10255552 has PRO of 60381249 05/16/2002

10255552 has PRO of 60353379 01/30/2002

10255552 has PRO of 60352761 01/29/2002

10255552 has PRO of 60335203 10/23/2001

10255552 has PRO of 60327327 10/04/2001

**FOREIGN APPLICATIONS**

**IF REQUIRED, FOREIGN LICENSE GRANTED\*\***

04/15/2020

**\*\* SMALL ENTITY \*\***

**STATE OR COUNTRY**

UNITED STATES

**ADDRESS**

MITCH HARRIS, LLC - GENERAL

P.O. BOX 1269

ATHENS, GA 30603-1269

UNITED STATES

**FILING FEE RECEIVED**

\$3,955



UNITED STATES PATENT AND TRADEMARK OFFICE

UNITED STATES DEPARTMENT OF COMMERCE
United States Patent and Trademark Office
Address: COMMISSIONER FOR PATENTS
P.O. Box 1450
Alexandria, Virginia 22313-1450
www.uspto.gov

NOTICE OF ALLOWANCE AND FEE(S) DUE

59911 7590 05/26/2020
MITCH HARRIS, LLC - GENERAL
P.O. BOX 1269
ATHENS, GA 30603-1269

EXAMINER

PATEL, AJIT

ART UNIT PAPER NUMBER

2416

DATE MAILED: 05/26/2020

Table with 5 columns: APPLICATION NO., FILING DATE, FIRST NAMED INVENTOR, ATTORNEY DOCKET NO., CONFIRMATION NO. Values: 16/788,498, 02/12/2020, Mark Jefferson Reed, TX1000-C12, 8054

TITLE OF INVENTION: MOBILE WIRELESS DEVICE PROVIDING OFF-LINE AND ON-LINE GEOGRAPHIC NAVIGATION INFORMATION

Table with 7 columns: APPLN. TYPE, ENTITY STATUS, ISSUE FEE DUE, PUBLICATION FEE DUE, PREV. PAID ISSUE FEE, TOTAL FEE(S) DUE, DATE DUE. Values: nonprovisional, SMALL, \$500, \$0.00, \$0.00, \$500, 08/26/2020

THE APPLICATION IDENTIFIED ABOVE HAS BEEN EXAMINED AND IS ALLOWED FOR ISSUANCE AS A PATENT. PROSECUTION ON THE MERITS IS CLOSED. THIS NOTICE OF ALLOWANCE IS NOT A GRANT OF PATENT RIGHTS. THIS APPLICATION IS SUBJECT TO WITHDRAWAL FROM ISSUE AT THE INITIATIVE OF THE OFFICE OR UPON PETITION BY THE APPLICANT. SEE 37 CFR 1.313 AND MPEP 1308.

THE ISSUE FEE AND PUBLICATION FEE (IF REQUIRED) MUST BE PAID WITHIN THREE MONTHS FROM THE MAILING DATE OF THIS NOTICE OR THIS APPLICATION SHALL BE REGARDED AS ABANDONED. THIS STATUTORY PERIOD CANNOT BE EXTENDED. SEE 35 U.S.C. 151. THE ISSUE FEE DUE INDICATED ABOVE DOES NOT REFLECT A CREDIT FOR ANY PREVIOUSLY PAID ISSUE FEE IN THIS APPLICATION. IF AN ISSUE FEE HAS PREVIOUSLY BEEN PAID IN THIS APPLICATION (AS SHOWN ABOVE), THE RETURN OF PART B OF THIS FORM WILL BE CONSIDERED A REQUEST TO REAPPLY THE PREVIOUSLY PAID ISSUE FEE TOWARD THE ISSUE FEE NOW DUE.

HOW TO REPLY TO THIS NOTICE:

I. Review the ENTITY STATUS shown above. If the ENTITY STATUS is shown as SMALL or MICRO, verify whether entitlement to that entity status still applies.

If the ENTITY STATUS is the same as shown above, pay the TOTAL FEE(S) DUE shown above.

If the ENTITY STATUS is changed from that shown above, on PART B - FEE(S) TRANSMITTAL, complete section number 5 titled "Change in Entity Status (from status indicated above)".

For purposes of this notice, small entity fees are 1/2 the amount of undiscounted fees, and micro entity fees are 1/2 the amount of small entity fees.

II. PART B - FEE(S) TRANSMITTAL, or its equivalent, must be completed and returned to the United States Patent and Trademark Office (USPTO) with your ISSUE FEE and PUBLICATION FEE (if required). If you are charging the fee(s) to your deposit account, section "4b" of Part B - Fee(s) Transmittal should be completed and an extra copy of the form should be submitted. If an equivalent of Part B is filed, a request to reapply a previously paid issue fee must be clearly made, and delays in processing may occur due to the difficulty in recognizing the paper as an equivalent of Part B.

III. All communications regarding this application must give the application number. Please direct all communications prior to issuance to Mail Stop ISSUE FEE unless advised to the contrary.

IMPORTANT REMINDER: Maintenance fees are due in utility patents issuing on applications filed on or after Dec. 12, 1980. It is patentee's responsibility to ensure timely payment of maintenance fees when due. More information is available at www.uspto.gov/PatentMaintenanceFees.

**PART B - FEE(S) TRANSMITTAL**

Complete and send this form, together with applicable fee(s), by mail or fax, or via EFS-Web.

By mail, send to: Mail Stop ISSUE FEE  
Commissioner for Patents  
P.O. Box 1450  
Alexandria, Virginia 22313-1450

By fax, send to: (571)-273-2885

**INSTRUCTIONS:** This form should be used for transmitting the ISSUE FEE and PUBLICATION FEE (if required). Blocks 1 through 5 should be completed where appropriate. All further correspondence including the Patent, advance orders and notification of maintenance fees will be mailed to the current correspondence address as indicated unless corrected below or directed otherwise in Block 1, by (a) specifying a new correspondence address; and/or (b) indicating a separate "FEE ADDRESS" for maintenance fee notifications.

CURRENT CORRESPONDENCE ADDRESS (Note: Use Block 1 for any change of address)

59911 7590 05/26/2020  
MITCH HARRIS, LLC - GENERAL  
P.O. BOX 1269  
ATHENS, GA 30603-1269

Note: A certificate of mailing can only be used for domestic mailings of the Fee(s) Transmittal. This certificate cannot be used for any other accompanying papers. Each additional paper, such as an assignment or formal drawing, must have its own certificate of mailing or transmission.

**Certificate of Mailing or Transmission**

I hereby certify that this Fee(s) Transmittal is being deposited with the United States Postal Service with sufficient postage for first class mail in an envelope addressed to the Mail Stop ISSUE FEE address above, or being transmitted to the USPTO via EFS-Web or by facsimile to (571) 273-2885, on the date below.

|                         |
|-------------------------|
| (Typed or printed name) |
| (Signature)             |
| (Date)                  |

| APPLICATION NO. | FILING DATE | FIRST NAMED INVENTOR | ATTORNEY DOCKET NO. | CONFIRMATION NO. |
|-----------------|-------------|----------------------|---------------------|------------------|
| 16/788,498      | 02/12/2020  | Mark Jefferson Reed  | TX1000-C12          | 8054             |

TITLE OF INVENTION: MOBILE WIRELESS DEVICE PROVIDING OFF-LINE AND ON-LINE GEOGRAPHIC NAVIGATION INFORMATION

| APPLN. TYPE    | ENTITY STATUS | ISSUE FEE DUE | PUBLICATION FEE DUE | PREV. PAID ISSUE FEE | TOTAL FEE(S) DUE | DATE DUE   |
|----------------|---------------|---------------|---------------------|----------------------|------------------|------------|
| nonprovisional | SMALL         | \$500         | \$0.00              | \$0.00               | \$500            | 08/26/2020 |

| EXAMINER    | ART UNIT | CLASS-SUBCLASS |
|-------------|----------|----------------|
| PATEL, AJIT | 2416     | 455-456300     |

|   |   |
|---|---|
| <p>1. Change of correspondence address or indication of "Fee Address" (37 CFR 1.363).</p> <p><input type="checkbox"/> Change of correspondence address (or Change of Correspondence Address form PTO/SB/122) attached.</p> <p><input type="checkbox"/> "Fee Address" indication (or "Fee Address" Indication form PTO/SB/47; Rev 03-09 or more recent) attached. <b>Use of a Customer Number is required.</b></p> | <p>2. For printing on the patent front page, list</p> <p>(1) The names of up to 3 registered patent attorneys or agents OR, alternatively, 1 _____</p> <p>(2) The name of a single firm (having as a member a registered attorney or agent) and the names of up to 2 registered patent attorneys or agents. If no name is listed, no name will be printed. 2 _____</p> <p>3 _____</p> |
|---|---|

**3. ASSIGNEE NAME AND RESIDENCE DATA TO BE PRINTED ON THE PATENT** (print or type)

PLEASE NOTE: Unless an assignee is identified below, no assignee data will appear on the patent. If an assignee is identified below, the document must have been previously recorded, or filed for recordation, as set forth in 37 CFR 3.11 and 37 CFR 3.81(a). Completion of this form is NOT a substitute for filing an assignment.

(A) NAME OF ASSIGNEE \_\_\_\_\_ (B) RESIDENCE: (CITY and STATE OR COUNTRY) \_\_\_\_\_

Please check the appropriate assignee category or categories (will not be printed on the patent) :  Individual  Corporation or other private group entity  Government

4a. Fees submitted:  Issue Fee  Publication Fee (if required)  Advance Order - # of Copies \_\_\_\_\_

4b. Method of Payment: (Please first reapply any previously paid fee shown above)

Electronic Payment via EFS-Web  Enclosed check  Non-electronic payment by credit card (Attach form PTO-2038)

The Director is hereby authorized to charge the required fee(s), any deficiency, or credit any overpayment to Deposit Account No. \_\_\_\_\_

**5. Change in Entity Status** (from status indicated above)

Applicant certifying micro entity status. See 37 CFR 1.29

Applicant asserting small entity status. See 37 CFR 1.27

Applicant changing to regular undiscounted fee status.

**NOTE:** Absent a valid certification of Micro Entity Status (see forms PTO/SB/15A and 15B), issue fee payment in the micro entity amount will not be accepted at the risk of application abandonment.

**NOTE:** If the application was previously under micro entity status, checking this box will be taken to be a notification of loss of entitlement to micro entity status.

**NOTE:** Checking this box will be taken to be a notification of loss of entitlement to small or micro entity status, as applicable.

NOTE: This form must be signed in accordance with 37 CFR 1.31 and 1.33. See 37 CFR 1.4 for signature requirements and certifications.

Authorized Signature \_\_\_\_\_ Date \_\_\_\_\_

Typed or printed name \_\_\_\_\_ Registration No. \_\_\_\_\_



UNITED STATES PATENT AND TRADEMARK OFFICE

UNITED STATES DEPARTMENT OF COMMERCE
United States Patent and Trademark Office
Address: COMMISSIONER FOR PATENTS
P.O. Box 1450
Alexandria, Virginia 22313-1450
www.uspto.gov

Table with columns: APPLICATION NO., FILING DATE, FIRST NAMED INVENTOR, ATTORNEY DOCKET NO., CONFIRMATION NO., EXAMINER, ART UNIT, PAPER NUMBER. Includes application details for Mitch Harris, LLC and examiner Patel, AJT.

Determination of Patent Term Adjustment under 35 U.S.C. 154 (b)
(Applications filed on or after May 29, 2000)

The Office has discontinued providing a Patent Term Adjustment (PTA) calculation with the Notice of Allowance.

Section 1(h)(2) of the AIA Technical Corrections Act amended 35 U.S.C. 154(b)(3)(B)(i) to eliminate the requirement that the Office provide a patent term adjustment determination with the notice of allowance. See Revisions to Patent Term Adjustment, 78 Fed. Reg. 19416, 19417 (Apr. 1, 2013). Therefore, the Office is no longer providing an initial patent term adjustment determination with the notice of allowance. The Office will continue to provide a patent term adjustment determination with the Issue Notification Letter that is mailed to applicant approximately three weeks prior to the issue date of the patent, and will include the patent term adjustment on the patent. Any request for reconsideration of the patent term adjustment determination (or reinstatement of patent term adjustment) should follow the process outlined in 37 CFR 1.705.

Any questions regarding the Patent Term Extension or Adjustment determination should be directed to the Office of Patent Legal Administration at (571)-272-7702. Questions relating to issue and publication fee payments should be directed to the Customer Service Center of the Office of Patent Publication at 1-(888)-786-0101 or (571)-272-4200.

## OMB Clearance and PRA Burden Statement for PTOL-85 Part B

The Paperwork Reduction Act (PRA) of 1995 requires Federal agencies to obtain Office of Management and Budget approval before requesting most types of information from the public. When OMB approves an agency request to collect information from the public, OMB (i) provides a valid OMB Control Number and expiration date for the agency to display on the instrument that will be used to collect the information and (ii) requires the agency to inform the public about the OMB Control Number's legal significance in accordance with 5 CFR 1320.5(b).

The information collected by PTOL-85 Part B is required by 37 CFR 1.311. The information is required to obtain or retain a benefit by the public which is to file (and by the USPTO to process) an application. Confidentiality is governed by 35 U.S.C. 122 and 37 CFR 1.14. This collection is estimated to take 30 minutes to complete, including gathering, preparing, and submitting the completed application form to the USPTO. Time will vary depending upon the individual case. Any comments on the amount of time you require to complete this form and/or suggestions for reducing this burden, should be sent to the Chief Information Officer, U.S. Patent and Trademark Office, U.S. Department of Commerce, P.O. Box 1450, Alexandria, Virginia 22313-1450. **DO NOT SEND FEES OR COMPLETED FORMS TO THIS ADDRESS. SEND TO: Commissioner for Patents, P.O. Box 1450, Alexandria, Virginia 22313-1450.** Under the Paperwork Reduction Act of 1995, no persons are required to respond to a collection of information unless it displays a valid OMB control number.

### Privacy Act Statement

**The Privacy Act of 1974 (P.L. 93-579)** requires that you be given certain information in connection with your submission of the attached form related to a patent application or patent. Accordingly, pursuant to the requirements of the Act, please be advised that: (1) the general authority for the collection of this information is 35 U.S.C. 2(b) (2); (2) furnishing of the information solicited is voluntary; and (3) the principal purpose for which the information is used by the U.S. Patent and Trademark Office is to process and/or examine your submission related to a patent application or patent. If you do not furnish the requested information, the U.S. Patent and Trademark Office may not be able to process and/or examine your submission, which may result in termination of proceedings or abandonment of the application or expiration of the patent.

The information provided by you in this form will be subject to the following routine uses:

1. The information on this form will be treated confidentially to the extent allowed under the Freedom of Information Act (5 U.S.C. 552) and the Privacy Act (5 U.S.C. 552a). Records from this system of records may be disclosed to the Department of Justice to determine whether disclosure of these records is required by the Freedom of Information Act.
2. A record from this system of records may be disclosed, as a routine use, in the course of presenting evidence to a court, magistrate, or administrative tribunal, including disclosures to opposing counsel in the course of settlement negotiations.
3. A record in this system of records may be disclosed, as a routine use, to a Member of Congress submitting a request involving an individual, to whom the record pertains, when the individual has requested assistance from the Member with respect to the subject matter of the record.
4. A record in this system of records may be disclosed, as a routine use, to a contractor of the Agency having need for the information in order to perform a contract. Recipients of information shall be required to comply with the requirements of the Privacy Act of 1974, as amended, pursuant to 5 U.S.C. 552a(m).
5. A record related to an International Application filed under the Patent Cooperation Treaty in this system of records may be disclosed, as a routine use, to the International Bureau of the World Intellectual Property Organization, pursuant to the Patent Cooperation Treaty.
6. A record in this system of records may be disclosed, as a routine use, to another federal agency for purposes of National Security review (35 U.S.C. 181) and for review pursuant to the Atomic Energy Act (42 U.S.C. 218(c)).
7. A record from this system of records may be disclosed, as a routine use, to the Administrator, General Services, or his/her designee, during an inspection of records conducted by GSA as part of that agency's responsibility to recommend improvements in records management practices and programs, under authority of 44 U.S.C. 2904 and 2906. Such disclosure shall be made in accordance with the GSA regulations governing inspection of records for this purpose, and any other relevant (i.e., GSA or Commerce) directive. Such disclosure shall not be used to make determinations about individuals.
8. A record from this system of records may be disclosed, as a routine use, to the public after either publication of the application pursuant to 35 U.S.C. 122(b) or issuance of a patent pursuant to 35 U.S.C. 151. Further, a record may be disclosed, subject to the limitations of 37 CFR 1.14, as a routine use, to the public if the record was filed in an application which became abandoned or in which the proceedings were terminated and which application is referenced by either a published application, an application open to public inspection or an issued patent.
9. A record from this system of records may be disclosed, as a routine use, to a Federal, State, or local law enforcement agency, if the USPTO becomes aware of a violation or potential violation of law or regulation.

|                               |                                      |                                    |                                |
|-------------------------------|--------------------------------------|------------------------------------|--------------------------------|
| <b>Notice of Allowability</b> | <b>Application No.</b><br>16/788,498 | <b>Applicant(s)</b><br>Reed et al. |                                |
|                               | <b>Examiner</b><br>AJIT PATEL        | <b>Art Unit</b><br>2416            | <b>AIA (FITF) Status</b><br>No |

**-- The MAILING DATE of this communication appears on the cover sheet with the correspondence address--**

All claims being allowable, PROSECUTION ON THE MERITS IS (OR REMAINS) CLOSED in this application. If not included herewith (or previously mailed), a Notice of Allowance (PTOL-85) or other appropriate communication will be mailed in due course. **THIS NOTICE OF ALLOWABILITY IS NOT A GRANT OF PATENT RIGHTS.** This application is subject to withdrawal from issue at the initiative of the Office or upon petition by the applicant. See 37 CFR 1.313 and MPEP 1308.

1.  This communication is responsive to 2/12/20.  
 A declaration(s)/affidavit(s) under **37 CFR 1.130(b)** was/were filed on \_\_\_\_\_.
2.  An election was made by the applicant in response to a restriction requirement set forth during the interview on \_\_\_\_\_; the restriction requirement and election have been incorporated into this action.
3.  The allowed claim(s) is/are 1,3-6,9-18,20-21,23-27 and 29-30. As a result of the allowed claim(s), you may be eligible to benefit from the **Patent Prosecution Highway** program at a participating intellectual property office for the corresponding application. For more information, please see [http://www.uspto.gov/patents/init\\_events/pph/index.jsp](http://www.uspto.gov/patents/init_events/pph/index.jsp) or send an inquiry to [PPHfeedback@uspto.gov](mailto:PPHfeedback@uspto.gov).
4.  Acknowledgment is made of a claim for foreign priority under 35 U.S.C. § 119(a)-(d) or (f).

**Certified copies:**

- a)  All      b)  Some      \*c)  None of the:
1.  Certified copies of the priority documents have been received.
  2.  Certified copies of the priority documents have been received in Application No. \_\_\_\_\_.
  3.  Copies of the certified copies of the priority documents have been received in this national stage application from the International Bureau (PCT Rule 17.2(a)).

\* Certified copies not received: \_\_\_\_\_.

Applicant has THREE MONTHS FROM THE "MAILING DATE" of this communication to file a reply complying with the requirements noted below. Failure to timely comply will result in ABANDONMENT of this application.

**THIS THREE-MONTH PERIOD IS NOT EXTENDABLE.**

5.  CORRECTED DRAWINGS (as "replacement sheets") must be submitted.  
 including changes required by the attached Examiner's Amendment / Comment or in the Office action of Paper No./Mail Date \_\_\_\_\_.  
**Identifying indicia such as the application number (see 37 CFR 1.84(c)) should be written on the drawings in the front (not the back) of each sheet. Replacement sheet(s) should be labeled as such in the header according to 37 CFR 1.121(d).**
6.  DEPOSIT OF and/or INFORMATION about the deposit of BIOLOGICAL MATERIAL must be submitted. Note the attached Examiner's comment regarding REQUIREMENT FOR THE DEPOSIT OF BIOLOGICAL MATERIAL.

**Attachment(s)**

- |   |   |
|---|---|
| <ol style="list-style-type: none"> <li>1. <input checked="" type="checkbox"/> Notice of References Cited (PTO-892)</li> <li>2. <input checked="" type="checkbox"/> Information Disclosure Statements (PTO/SB/08),<br/>Paper No./Mail Date _____.</li> <li>3. <input type="checkbox"/> Examiner's Comment Regarding Requirement for Deposit<br/>of Biological Material _____.</li> <li>4. <input checked="" type="checkbox"/> Interview Summary (PTO-413),<br/>Paper No./Mail Date _____.</li> </ol> | <ol style="list-style-type: none"> <li>5. <input checked="" type="checkbox"/> Examiner's Amendment/Comment</li> <li>6. <input checked="" type="checkbox"/> Examiner's Statement of Reasons for Allowance</li> <li>7. <input type="checkbox"/> Other _____.</li> </ol> |
|---|---|

|   |  |
|---|--|
| /AJIT PATEL/<br>Primary Examiner, Art Unit 2416 |  |
|---|--|



**DETAILED ACTION**

***Notice of Pre-AIA or AIA Status***

1. The present application is being examined under the pre-AIA first to invent provisions.

**EXAMINER'S AMENDMENT**

2. An examiner's amendment to the record appears below. Should the changes and/or additions be unacceptable to applicant, an amendment may be filed as provided by 37 CFR 1.312. To ensure consideration of such an amendment, it **MUST** be submitted no later than the payment of the issue fee.

Authorization for this examiner's amendment was given in an interview with Mr. Harris on 5/18/20.

3. The application has been amended as follows:

1. (Currently amended) A wireless communications system including:

a first radio-frequency transceiver within a wireless mobile communications device and an associated first antenna to which the first radio-frequency transceiver is coupled, wherein the first radio-frequency transceiver is configured for radio-frequency communication with a wireless communications network;

a first processor within the wireless mobile communications device coupled to the at least one first radio-frequency transceiver programmed to receive information indicative of a location of the wireless mobile communications device ~~from the wireless communications network~~ and generate an indication of a location of the wireless mobile communications device with respect to geographic features according to mapping information stored within the wireless mobile communications device, and wherein the

first processor determines user navigation information and displays to the user  
navigation information according to the location of the wireless mobile communications  
device with respect to the geographic features and a destination specified ~~by the user~~ at  
the wireless mobile communications device, wherein the first processor further sends  
the user navigation information to the network as a number of segments, wherein at  
least one other processor outside the network updates the user navigation information  
in conformity with traffic congestion information accessible to the at least one other  
processor outside the network by computing a numerical value for the segments  
corresponding to the expected time to travel through the segments, updates the user  
navigation information in conformity with the numerical values for the segments, and  
sends the updated user navigation information to the wireless mobile communications  
device;

at least one second radio-frequency transceiver and an associated at least one  
second antenna of the wireless communications network to which the second radio-  
frequency transceiver is coupled; and

a second processor coupled to the at least one second radio-frequency  
transceiver programmed to acquire the information indicative of a location of the  
wireless mobile communications device, wherein the second processor selectively  
acquires the information indicative of a location of the wireless mobile communications  
device dependent on the setting of preference flags, wherein the second processor  
acquires the information indicative of a location of the wireless mobile communications  
device if the preference flags are set to a state that permits tracking ~~of the user~~ of the  
wireless mobile communications device, and wherein the second processor does not

acquire the information indicative of the location of the wireless mobile communications device if the preference flags are set to a state that prohibits tracking of the wireless mobile communications device.

2. (Canceled)

3. (Currently Amended) The wireless communications system of Claim 1, wherein the first processor is further programmed to:

determine whether or not the mapping information stored within the wireless mobile communications device is sufficient to display the navigation information ~~to the user~~;

responsive to the first processor determining that the mapping information is sufficient, the processor displaying the navigation information ~~to the user~~;

responsive to the first processor determining that the mapping information is not sufficient, the first processor requesting additional mapping information from at least one other processor outside the wireless communications network; and

responsive to the first processor requesting additional mapping information from at least one other processor outside the wireless communications network, the first processor receiving the additional mapping information from the at least one other processor outside the wireless communications network and the first processor displaying the navigation information ~~to the user~~ using the additional mapping information.

4. (Original) The wireless communications system of Claim 3, wherein the first processor further updates the mapping information stored within the wireless mobile communications device with the additional information received from the wireless communications network.

5. (Currently Amended) The wireless communications system of Claim 4, wherein the first processor, responsive to not receiving the additional mapping information from the wireless communications network, ~~displaying~~ displays a notice ~~to the user~~ that the destination could not be found.

6. (Original) The wireless communications system of Claim 2, wherein the first processor further requests from the wireless communications network, traffic congestion information, wherein the first processor receives the requested traffic congestion information and determines the user navigation information in conformity with the received traffic congestion information.

Claims 7-8 are canceled.

9. (Currently Amended) The wireless communications system of Claim 17, wherein the another processor determines whether or not the updated user navigation information already exists in the wireless mobile communications device, and does not transmit the updated user navigation information to the wireless mobile communications device if the

updated user navigation information already exists in the wireless mobile communications device.

10. (Original) The wireless communications system of Claim 1, wherein the first processor further sends the indication of a location of the wireless mobile communications device with respect to the geographic features to the network, wherein at least one other processor outside the network receives the indication of a location of the wireless mobile communications device, determines the user navigation information in conformity with the location of the wireless mobile communications device and transmits the user navigation information to the wireless mobile communications device.

11. (Original) The wireless communications system of Claim 1, wherein the preference flags are specified by ~~the user~~ of the wireless mobile communications device and transmitted to the at least one second radio-frequency transceiver.

12. (Original) The wireless communications system of Claim 1, wherein the preference flags have more than two states including at least: a first state that prohibits tracking of the mobile wireless communications device, a second state that permits open access to the location of the wireless mobile communications device and information associated with the wireless mobile communications device, and a third state that provides access to the information indicative of the location of the wireless mobile communications device but not information associated with the wireless mobile communications device other than a generic identifier, and wherein the second processor provides information

about ~~the~~ a user of the wireless mobile communications device to at least one other processor outside the network in conformity with permissions specified by the preference flags.

13. (Currently Amended) The wireless communications system of Claim 12, wherein the preference flags have more than three states, including at least a fourth state that provides access to the location of the wireless mobile communications device and demographic information associated with the wireless mobile communications device, but not a name of the user associated with the wireless mobile communications device or other private information.

14. (Currently Amended) A method of providing navigation information within a wireless communications network, the method comprising:

at a wireless mobile communications device coupled to the wireless communications network and having a first radio-frequency transceiver coupled to an associated first antenna, receiving information indicative of a location of the mobile wireless communications device;

within the wireless mobile communications device, a first processor within the wireless mobile communications device coupled to the first radio-frequency transceiver generating an indication of a location of the at least one wireless mobile communications device with respect to geographic features according to mapping information retrieved from a storage within the wireless mobile communications device;

the first processor determining user navigation information;

sending the user navigation information to the at least one other processor outside the network as a number of segments;

at a remote location within the at least one other processor outside the network, updating the user navigation information in conformity with traffic congestion information accessible to the remote location within the network by computing a numerical value for the segments corresponding to the expected time to travel through the segments, and wherein the updating is performed in conformity with the numerical values for the number of segments;

sending the updated user navigation information to the wireless mobile communications device;

the first processor displaying ~~to the user~~ the user navigation information according to the location of the wireless mobile communications device with respect to the geographic features and a destination specified by ~~the user at~~ the wireless mobile communications device;

within the wireless communications network, a second processor coupled to at least one second radio-frequency transceiver coupled to an associated second antenna selectively acquiring the information indicative of a location of the wireless mobile communication device in dependence on a setting of preference flags, wherein the selectively acquiring the information indicative of a location of the wireless mobile communications device if the preference flags are set to a state that permits tracking of the user of the wireless mobile communications device, and wherein the selectively determining does not acquire the information indicative of a location of the wireless mobile communications device if the preference flags are set to a state that prohibits tracking of the wireless mobile communications device.

15. (Original)The method of Claim 14, further comprising within the wireless mobile communications device, determining the user navigation information.

16. (Currently Amended) The method of Claim 15, further comprising:

within the wireless mobile communications device, determining whether or not the mapping information stored within the wireless mobile communications device is sufficient to display the navigation information ~~to the user~~;



responsive to determining that the mapping information is sufficient, displaying the navigation information ~~to the user~~;

responsive to determining that the mapping information is not sufficient, requesting additional mapping information from at least one other processor outside the wireless communications network; and

responsive to the requesting additional mapping information from the at least one other processor outside the wireless communications network, receiving the additional mapping information from the at least one other processor outside the wireless communications network and displaying the navigation information ~~to the user~~ using the additional mapping information.

17. (Original) The method of Claim 16, further comprising updating the mapping information stored within the wireless mobile communications device with the additional information received from the at least one other processor outside the wireless communications network.

18. (Currently Amended) The method of Claim 16, further comprising responsive to not receiving the additional mapping information from the at least one other processor outside the wireless communications network, displaying a notice ~~to the user~~ that the destination could not be found.

19. (Canceled)

20. (Original) The method of Claim 19, further comprising, at the remote location, determining whether or not the updated user navigation information already exists in the wireless mobile communications device, and wherein the transmitting of the updated user navigation information is not performed if the updated user navigation information already exists in the wireless mobile communications device.

21. (Original) The method of Claim 14, further comprising:  
    requesting from the at least one other processor outside the wireless communications network, traffic congestion information;  
    receiving the requested traffic congestion information at the mobile wireless communications device; and  
    determining the user navigation information in conformity with the received traffic congestion information.

22. (Canceled)

23. (Original) The method of Claim 14, further comprising:  
    at the wireless mobile communications device, sending the location of the wireless mobile communications device with respect to the geographic features to at least one other processor outside the network;  
    receiving the location of the wireless mobile communications device at the at least one other processor outside the network; and  
    at a remote at least one other processor outside the network, determining the user navigation information in conformity with the location of the wireless mobile communications device; and

transmitting the user navigation information to the wireless mobile communications device.

24. (Currently Amended) The method of Claim 14, wherein the preference flags are specified by ~~the~~ a user associated with ~~of~~ the wireless mobile communications device, and wherein the method further comprises transmitting the preference flags to the at least one second radio-frequency transceiver.

25. (Currently Amended) The method of Claim 14, wherein the preference flags have more than two states including at least: a first state that prohibits tracking of the mobile wireless communications device, a second state that permits open access to the location of the wireless mobile communications device and information associated with the wireless mobile communications device, and a third state that provides access to the location of the wireless mobile communications device but not information associated with the wireless mobile communications device other than a generic identifier, and wherein method further comprises the second processor providing information about a the user of associated with ~~the~~ the wireless mobile communications device to at least one other processor outside the wireless network in conformity with permissions specified by the preference flags.

26. (Original) The method of Claim 25, wherein the preference flags have more than three states, including at least a fourth state that provides access to the location of the wireless mobile communications device and demographic information associated with

the wireless mobile communications device, but not a name of the user associated with the wireless mobile communications device or other private information.

27. (Currently Amended) A wireless mobile communications device including:

a radio-frequency transceiver and an associated antenna to which the radio-frequency transceiver is coupled, wherein the radio-frequency transceiver is configured for radio-frequency communication with a wireless communications network; and

a first processor coupled to the at least one radio-frequency transceiver programmed to receive a location of the wireless mobile communications device and generate an indication of a location of the at least one wireless mobile communications device with respect to geographic features according to mapping information stored within the wireless mobile communications device, wherein the first processor determines whether or not the mapping information stored within the wireless mobile communications device is sufficient to display the navigation information to the user, responsive to the first processor determining that the mapping information is not sufficient, the first processor requesting additional mapping information from at least one other processor outside the wireless communications network and responsive to the first processor requesting additional mapping information from the at least one other processor outside the wireless communications network, receiving the additional mapping information from the at least one other processor outside the wireless communications network and updating the mapping information stored within the wireless mobile communications device, wherein the first processor determines and displays the navigation information to the user using the additional mapping information, the location of the wireless mobile communications device with respect to the

geographic features and a destination specified by the user at the wireless mobile communications device, and wherein the first processor communicates to the mobile communications network a setting of preference flags, wherein the first processor further sends the user navigation information to the at least one other processor outside of the network, wherein the at least one other processor outside of the network updates the user navigation information in conformity with traffic congestion information accessible to the other processor coupled to the network and transmits the updated user navigation information to the mobile device, wherein the first processor further sends the user navigation information to the at least one other processor outside of the network as a number of segments, and wherein the at least one other processor outside of the network computes a numerical value for each segment corresponding to the expected time to travel through the segment and wherein the user navigation information is updated in conformity with the numerical values for the number of segments, wherein ~~whereby~~ the mobile communications network selectively acquires information indicative of a location of the mobile communications device and communicates the information indicative of a location of the wireless mobile communications device to the wireless mobile communications device dependent on the setting of the preference flags, wherein if the preference flags are set to a state that permits tracking of the user of the wireless mobile communications device the at least one other processor outside the wireless communications network receives the location of the wireless mobile communications device, and wherein if the preference flags are set to a state that prohibits tracking of the wireless mobile communications device, the

at least one other processor outside the wireless communications network does not receive the location of the wireless mobile communications device.

28. (Canceled).

29. (Currently Amended) The wireless mobile communications device of Claim 27 ~~28~~, wherein the another processor determines whether or not the updated user navigation information already exists in the wireless mobile communications device, and does not transmit the updated user navigation information to the mobile device if the updated user navigation information already exists in the wireless mobile communications device.

30. (Original) The wireless mobile communications device of Claim 27, wherein the preference flags have more than two states including at least: a first state that prohibits tracking of the mobile wireless communications device, a second state that permits open access to the location of the wireless mobile communications device and information associated with the wireless mobile communications device, and a third state that provides access to the location of the wireless mobile communications device but not information associated with the wireless mobile communications device other than a generic identifier, whereby the wireless communications network processor provides information about the user of the wireless mobile communications device in conformity with permissions specified by the preference flags.

**EXAMINER'S AMENDMENT**

***Allowable Subject Matter***

4. The following is an examiner's statement of reasons for allowance: The prior art of Stilp fail to disclose

1. A wireless communications system including:

a first radio-frequency transceiver within a wireless mobile communications device and an associated first antenna to which the first radio-frequency transceiver is coupled, wherein the first radio-frequency transceiver is configured for radio-frequency communication with a wireless communications network;

a first processor within the wireless mobile communications device coupled to the at least one first radio-frequency transceiver programmed to receive information indicative of a location of the wireless mobile communications device and generate an indication of a location of the wireless mobile communications device with respect to geographic features according to mapping information stored within the wireless mobile communications device, and wherein the first processor determines user navigation information and displays the user navigation information according to the location of the wireless mobile communications device with respect to the geographic features and a destination specified at the wireless mobile communications device, wherein the first processor further sends the user navigation information to the network as a number of segments, wherein at least one other processor outside the network updates the user navigation information in conformity with traffic congestion information accessible to the at least one other processor outside the network by computing a numerical value for the segments corresponding to the expected time to travel through the segments, updates

the user navigation information in conformity with the numerical values for the segments, and sends the updated user navigation information to the wireless mobile communications device;

at least one second radio-frequency transceiver and an associated at least one second antenna of the wireless communications network to which the second radio-frequency transceiver is coupled; and

a second processor coupled to the at least one second radio-frequency transceiver programmed to acquire the information indicative of a location of the wireless mobile communications device, wherein the second processor selectively acquires the information indicative of a location of the wireless mobile communications device dependent on the setting of preference flags, wherein the second processor acquires the information indicative of a location of the wireless mobile communications device if the preference flags are set to a state that permits tracking of the wireless mobile communications device, and wherein the second processor does not acquire the information indicative of the location of the wireless mobile communications device if the preference flags are set to a state that prohibits tracking of the wireless mobile communications device.

14. A method of providing navigation information within a wireless communications network, the method comprising:

at a wireless mobile communications device coupled to the wireless communications network and having a first radio-frequency transceiver coupled to an associated first antenna, receiving information indicative of a location of the mobile wireless communications device;



within the wireless mobile communications device, a first processor within the wireless mobile communications device coupled to the first radio-frequency transceiver generating an indication of a location of the at least one wireless mobile communications device with respect to geographic features according to mapping information retrieved from a storage within the wireless mobile communications device;

the first processor determining user navigation information;

sending the user navigation information to the at least one other processor outside the network as a number of segments;

at a remote location within the at least one other processor outside the network, updating the user navigation information in conformity with traffic congestion information accessible to the remote location within the network by computing a numerical value for the segments corresponding to the expected time to travel through the segments, and wherein the updating is performed in conformity with the numerical values for the number of segments;

sending the updated user navigation information to the wireless mobile communications device;

the first processor displaying the user navigation information according to the location of the wireless mobile communications device with respect to the geographic features and a destination specified by the wireless mobile communications device;

within the wireless communications network, a second processor coupled to at least one second radio-frequency transceiver coupled to an associated second antenna selectively acquiring the information indicative of a location of the wireless mobile communication device in dependence on a setting of preference flags.

wherein the selectively acquiring the information indicative of a location of the wireless mobile communications device if the preference flags are set to a state that permits tracking of the user of the wireless mobile communications device, and wherein the selectively determining does not acquire the information indicative of a location of the wireless mobile communications device if the preference flags are set to a state that prohibits tracking of the wireless mobile communications device.

27. A wireless mobile communications device including:

a radio-frequency transceiver and an associated antenna to which the radio-frequency transceiver is coupled, wherein the radio-frequency transceiver is configured for radio-frequency communication with a wireless communications network; and

a first processor coupled to the at least one radio-frequency transceiver programmed to receive a location of the wireless mobile communications device and generate an indication of a location of the at least one wireless mobile communications device with respect to geographic features according to mapping information stored within the wireless mobile communications device, wherein the first processor determines whether or not the mapping information stored within the wireless mobile communications device is sufficient to display the navigation information to the user, responsive to the first processor determining that the mapping information is not sufficient, the first processor requesting additional mapping information from at least one other processor outside the wireless communications network and responsive to the first processor requesting additional mapping information from the at least one other processor outside the wireless communications network, receiving the additional mapping information from the at least one other processor outside the wireless

communications network and updating the mapping information stored within the wireless mobile communications device, wherein the first processor determines and displays the navigation information to the user using the additional mapping information, the location of the wireless mobile communications device with respect to the geographic features and a destination specified by the user at the wireless mobile communications device, and wherein the first processor communicates to the mobile communications network a setting of preference flags, wherein the first processor further sends the user navigation information to the at least one other processor outside of the network, wherein the at least one other processor outside of the network updates the user navigation information in conformity with traffic congestion information accessible to the other processor coupled to the network and transmits the updated user navigation information to the mobile device, wherein the first processor further sends the user navigation information to the at least one other processor outside of the network as a number of segments, and wherein the at least one other processor outside of the network computes a numerical value for each segment corresponding to the expected time to travel through the segment and wherein the user navigation information is updated in conformity with the numerical values for the number of segments, wherein the mobile communications network selectively acquires information indicative of a location of the mobile communications device and communicates the information indicative of a location of the wireless mobile communications device to the wireless mobile communications device dependent on the setting of the preference flags, wherein if the preference flags are set to a state that permits tracking of the user of the wireless mobile communications device the at least

one other processor outside the wireless communications network receives the location of the wireless mobile communications device, and wherein if the preference flags are set to a state that prohibits tracking of the wireless mobile communications device, the at least one other processor outside the wireless communications network does not receive the location of the wireless mobile communications device.

Any comments considered necessary by applicant must be submitted no later than the payment of the issue fee and, to avoid processing delays, should preferably accompany the issue fee. Such submissions should be clearly labeled "Comments on Statement of Reasons for Allowance."

***Conclusion***

5. Any inquiry concerning this communication or earlier communications from the examiner should be directed to AJIT PATEL whose telephone number is (571)272-3140. The examiner can normally be reached on Monday-Friday 9AM-5PM.

Examiner interviews are available via telephone, in-person, and video conferencing using a USPTO supplied web-based collaboration tool. To schedule an interview, applicant is encouraged to use the USPTO Automated Interview Request (AIR) at <http://www.uspto.gov/interviewpractice>.

If attempts to reach the examiner by telephone are unsuccessful, the examiner's supervisor, NOEL BEHARRY can be reached on 571-270-5630. The fax phone number for the organization where this application or proceeding is assigned is 571-273-8300.

Information regarding the status of an application may be obtained from the Patent Application Information Retrieval (PAIR) system. Status information for published applications may be obtained from either Private PAIR or Public PAIR. Status information for unpublished applications is available through Private PAIR only. For more information about the PAIR system, see <https://ppair-my.uspto.gov/pair/PrivatePair>. Should you have questions on access to the Private PAIR system, contact the Electronic Business Center (EBC) at 866-217-9197 (toll-free). If you would like assistance from a USPTO Customer Service Representative or access to the automated information system, call 800-786-9199 (IN USA OR CANADA) or 571-272-1000.

/AJIT PATEL/  
Primary Examiner, Art Unit 2416

|  |                                      |                                    |                                |
|--|--------------------------------------|------------------------------------|--------------------------------|
| <b><i>Examiner-Initiated Interview Summary</i></b> | <b>Application No.</b><br>16/788,498 | <b>Applicant(s)</b><br>Reed et al. |                                |
|  | <b>Examiner</b><br>AJIT PATEL        | <b>Art Unit</b><br>2416            | <b>AIA (FITF) Status</b><br>No |

All participants (applicant, applicant's representative, PTO personnel):

(1) AJIT PATEL. (3) \_\_\_\_.

(2) Mr. M. Harris. (4) \_\_\_\_.

Date of Interview: 18 May 2020.

Type:  Telephonic  Video Conference  
 Personal [copy given to:  applicant  applicant's representative]

Exhibit shown or demonstration conducted:  Yes  No.

If Yes, brief description: \_\_\_\_.

Issues Discussed  101  112  102  103  Others  
(For each of the checked box(es) above, please describe below the issue and detailed description of the discussion)

Claim(s) discussed: 1-30.

Identification of prior art discussed: N/A.

**Substance of Interview**

(For each issue discussed, provide a detailed description and indicate if agreement was reached. Some topics may include: identification or clarification of a reference or a portion thereof, claim interpretation, proposed amendments, arguments of any applied references etc...)

The examiner and the attorney discussed about the allowable subject matter in the dependent claims. The attorney agreed to incorporate the allowable subject matter in all independent claims and authorized the examiner's amendment. The attorney also agreed to file the TD related to U. S. Pat. # 9549388.

**Applicant recordation instructions:** It is not necessary for applicant to provide a separate record of the substance of interview.

**Examiner recordation instructions:** Examiners must summarize the substance of any interview of record. A complete and proper recordation of the substance of an interview should include the items listed in MPEP 713.04 for complete and proper recordation including the identification of the general thrust of each argument or issue discussed, a general indication of any other pertinent matters discussed regarding patentability and the general results or outcome of the interview, to include an indication as to whether or not agreement was reached on the issues raised.

Attachment

/AJIT PATEL/  
Primary Examiner, Art Unit 2416

|                                   |                                       |   |             |
|-----------------------------------|---------------------------------------|---|-------------|
| <b>Notice of References Cited</b> | Application/Control No.<br>16/788,498 | Applicant(s)/Patent Under<br>Reexamination<br>Reed et al. |             |
|                                   | Examiner<br>AJIT PATEL                | Art Unit<br>2416  | Page 1 of 1 |

**U.S. PATENT DOCUMENTS**

| * | Document Number<br>Country Code-Number-Kind Code | Date<br>MM-YYYY | Name            | CPC Classification | US Classification |
|---|--|-----------------|-----------------|--------------------|-------------------|
| * | A US-6492944-B1                                  | 12-2002         | Stilp; Louis A. | G01S5/0284         | 342/387           |
| B |  |                 |                 |                    |                   |
| C |  |                 |                 |                    |                   |
| D |  |                 |                 |                    |                   |
| E |  |                 |                 |                    |                   |
| F |  |                 |                 |                    |                   |
| G |  |                 |                 |                    |                   |
| H |  |                 |                 |                    |                   |
| I |  |                 |                 |                    |                   |
| J |  |                 |                 |                    |                   |
| K |  |                 |                 |                    |                   |
| L |  |                 |                 |                    |                   |
| M |  |                 |                 |                    |                   |


**FOREIGN PATENT DOCUMENTS**

| * | Document Number<br>Country Code-Number-Kind Code | Date<br>MM-YYYY | Country | Name | CPC Classification |
|---|--|-----------------|---------|------|--------------------|
| N |  |                 |         |      |                    |
| O |  |                 |         |      |                    |
| P |  |                 |         |      |                    |
| Q |  |                 |         |      |                    |
| R |  |                 |         |      |                    |
| S |  |                 |         |      |                    |
| T |  |                 |         |      |                    |

**NON-PATENT DOCUMENTS**

| * | Include as applicable: Author, Title Date, Publisher, Edition or Volume, Pertinent Pages) |
|---|---|
| U |   |
| V |   |
| W |   |
| X |   |

\*A copy of this reference is not being furnished with this Office action. (See MPEP § 707.05(a).)  
Dates in MM-YYYY format are publication dates. Classifications may be US or foreign.

|  |  |   |
|--|--|---|
| <b>Issue Classification</b><br> | <b>Application/Control No.</b><br>16/788,498 | <b>Applicant(s)/Patent Under Reexamination</b><br>Reed et al. |
|  | <b>Examiner</b><br>AJIT PATEL                | <b>Art Unit</b><br>2416                                       |

| CPC    |   |    |   |      |      |            |
|--------|---|----|---|------|------|------------|
| Symbol |   |    |   |      | Type | Version    |
| H04W   | / | 4  | / | 023  | F    | 2013-01-01 |
| H04W   | / | 4  | / | 02   | I    | 2013-01-01 |
| H04W   | / | 8  | / | 02   | I    | 2013-01-01 |
| G01S   | / | 5  | / | 0252 | I    | 2013-01-01 |
| H04W   | / | 24 | / | 02   | I    | 2013-01-01 |
| H04B   | / | 17 | / | 318  | I    | 2015-01-15 |
| H04W   | / | 4  | / | 029  | I    | 2018-02-01 |
| H04W   | / | 64 | / | 006  | I    | 2013-01-01 |


| CPC Combination Sets |      |     |         |         |
|----------------------|------|-----|---------|---------|
| Symbol               | Type | Set | Ranking | Version |
| /                    | /    |     |         |         |

|   |             |                              |                   |
|---|-------------|------------------------------|-------------------|
| NONE  |             | <b>Total Claims Allowed:</b> |                   |
| (Assistant Examiner)                            | (Date)      | 24                           |                   |
| /AJIT PATEL/<br>Primary Examiner, Art Unit 2416 | 20 May 2020 | O.G. Print Claim(s)          | O.G. Print Figure |
| (Primary Examiner)                              | (Date)      | 1                            | 9                 |

U.S. Patent and Trademark Office

Part of Paper No.: 20200518




|  |  |   |
|--|--|---|
| <b>Issue Classification</b><br> | <b>Application/Control No.</b><br>16/788,498 | <b>Applicant(s)/Patent Under Reexamination</b><br>Reed et al. |
|  | <b>Examiner</b><br>AJIT PATEL                | <b>Art Unit</b><br>2416                                       |

|                                     |   |     |  |
|-------------------------------------|---|-----|--|
| <b>INTERNATIONAL CLASSIFICATION</b> |   |     |  |
| <b>CLAIMED</b>                      |   |     |  |
| H04W                                | 4 | 02  |  |
| H04W                                | 4 | 029 |  |
| <b>NON-CLAIMED</b>                  |   |     |  |
|                                     |   |     |  |

|                                   |                 |
|-----------------------------------|-----------------|
| <b>US ORIGINAL CLASSIFICATION</b> |                 |
| <b>CLASS</b>                      | <b>SUBCLASS</b> |
|                                   |                 |

|                            |  |  |  |  |  |
|----------------------------|--|--|--|--|--|
| <b>CROSS REFERENCES(S)</b> |  |  |  |  |  |
| <b>CLASS</b>               | <b>SUBCLASS (ONE SUBCLASS PER BLOCK)</b> |  |  |  |  |
|                            |  |  |  |  |  |


|   |             |                              |                   |
|---|-------------|------------------------------|-------------------|
| NONE  |             | <b>Total Claims Allowed:</b> |                   |
| (Assistant Examiner)                            | (Date)      | 24                           |                   |
| /AJIT PATEL/<br>Primary Examiner, Art Unit 2416 | 20 May 2020 | O.G. Print Claim(s)          | O.G. Print Figure |
| (Primary Examiner)                              | (Date)      | 1                            | 9                 |

|  |  |   |
|--|--|---|
| <b>Issue Classification</b><br> | <b>Application/Control No.</b><br>16/788,498 | <b>Applicant(s)/Patent Under Reexamination</b><br>Reed et al. |
|  | <b>Examiner</b><br>AJIT PATEL                | <b>Art Unit</b><br>2416                                       |

Claims renumbered in the same order as presented by applicant
  CPA
  T.D.
  R.1.47

| CLAIMS |          |       |          |       |          |       |          |       |          |       |          |       |          |       |          |
|--------|----------|-------|----------|-------|----------|-------|----------|-------|----------|-------|----------|-------|----------|-------|----------|
| Final  | Original | Final | Original | Final | Original | Final | Original | Final | Original | Final | Original | Final | Original | Final | Original |
| 1      | 1        | 7     | 10       |       | 19       |       | 28       |       |          |       |          |       |          |       |          |
|        | 2        | 8     | 11       | 16    | 20       | 23    | 29       |       |          |       |          |       |          |       |          |
| 2      | 3        | 9     | 12       | 17    | 21       | 24    | 30       |       |          |       |          |       |          |       |          |
| 3      | 4        | 10    | 13       |       | 22       |       |          |       |          |       |          |       |          |       |          |
| 4      | 5        | 11    | 14       | 18    | 23       |       |          |       |          |       |          |       |          |       |          |
| 5      | 6        | 12    | 15       | 19    | 24       |       |          |       |          |       |          |       |          |       |          |
|        | 7        | 13    | 16       | 20    | 25       |       |          |       |          |       |          |       |          |       |          |
|        | 8        | 14    | 17       | 21    | 26       |       |          |       |          |       |          |       |          |       |          |
| 6      | 9        | 15    | 18       | 22    | 27       |       |          |       |          |       |          |       |          |       |          |

|   |             |                              |                   |
|---|-------------|------------------------------|-------------------|
| NONE  |             | <b>Total Claims Allowed:</b> |                   |
| (Assistant Examiner)                            | (Date)      | 24                           |                   |
| /AJIT PATEL/<br>Primary Examiner, Art Unit 2416 | 20 May 2020 | O.G. Print Claim(s)          | O.G. Print Figure |
| (Primary Examiner)                              | (Date)      | 1                            | 9                 |

|  |  |   |
|--|--|---|
| <b>Search Notes</b><br> | <b>Application/Control No.</b><br>16/788,498 | <b>Applicant(s)/Patent Under Reexamination</b><br>Reed et al. |
|  | <b>Examiner</b><br>AJIT PATEL                | <b>Art Unit</b><br>2416                                       |

| CPC - Searched* |      |          |
|-----------------|------|----------|
| Symbol          | Date | Examiner |
|                 |      |          |


| CPC Combination Sets - Searched* |      |          |
|----------------------------------|------|----------|
| Symbol                           | Date | Examiner |
|                                  |      |          |

| US Classification - Searched* |          |      |          |
|-------------------------------|----------|------|----------|
| Class                         | Subclass | Date | Examiner |
|                               |          |      |          |

\* See search history printout included with this form or the SEARCH NOTES box below to determine the scope of the search.

| Search Notes  |            |          |
|---|------------|----------|
| Search Notes  | Date       | Examiner |
| IPR2019-00324 Reviewed Petition for Inter Partes Review of U.S.Patent No. 9,642,024.              | 05/07/2020 | AP       |
| IPR2019-00326 Reviewed Petition for Inter Partes Review of U.S.Patent No. 9,510,320.              | 05/07/2020 | AP       |
| IPR2019-00327 Reviewed Petition for Inter Partes Review of U.S.Patent No. 8,977,284.              | 05/07/2020 | AP       |
| Inventor name searched  | 05/20/2020 | AP       |
| H04W4/023;H04W64/006;H04W24/02;G01S5/0252;H04W4/029;H04W4/02;H04W8/02;H04B17/318-LIMITED SEARCHED | 05/20/2020 | AP       |
| (H04W\$/\$.)CPC.-LIMITED SEARCHED   | 05/20/2020 | AP       |
| (H04B\$/\$.)CPC.-LIMITED SEARCHED   | 05/20/2020 | AP       |
| (G01S\$/\$.)CPC.-LIMITED SEARCHED   | 05/20/2020 | AP       |
| EAST  | 05/20/2020 | AP       |

|  |  |
|--|--|
|  |  |
|--|--|

|   |  |   |
|---|--|---|
| <b><i>Search Notes</i></b><br> | <b>Application/Control No.</b><br>16/788,498 | <b>Applicant(s)/Patent Under Reexamination</b><br>Reed et al. |
|   | <b>Examiner</b><br>AJIT PATEL                | <b>Art Unit</b><br>2416                                       |

| <b>Interference Search</b> |                                    |             |                 |
|----------------------------|------------------------------------|-------------|-----------------|
| <b>US Class/CPC Symbol</b> | <b>US Subclass/CPC Group</b>       | <b>Date</b> | <b>Examiner</b> |
|                            | See EAST for interference searched | 05/20/2020  | AP              |

|  |  |
|--|--|
|  |  |
|--|--|

**EAST Search History**

**EAST Search History (Prior Art)**

| Ref # | Hits   | Search Query   | DBs  | Default Operator | Plurals | Time Stamp          |
|-------|--------|--|--|------------------|---------|---------------------|
| L1    | 202705 | (H04W4/023 or H04W64/006 or H04W24/02 or G01S5/0252 or H04W4/029 or H04W4/02 or H04W8/02 or H04B17/318).cpc.   | US-PGPUB;<br>USPAT; USOCR;<br>FPRS; EPO; JPO;<br>DERWENT;<br>IBM_TDB | OR               | ON      | 2020/05/20<br>19:27 |
| L2    | 32     | (Stephen near2 Palik).in.  | US-PGPUB;<br>USPAT; USOCR;<br>FPRS; EPO; JPO;<br>DERWENT;<br>IBM_TDB | OR               | ON      | 2020/05/20<br>19:30 |
| L3    | 773    | (Mark near2 Reed).in.  | US-PGPUB;<br>USPAT; USOCR;<br>FPRS; EPO; JPO;<br>DERWENT;<br>IBM_TDB | OR               | ON      | 2020/05/20<br>19:30 |
| L4    | 1      | 2 and (geographic and location and map\$5 and flag and state and track\$5 and permit and prohibit)   | US-PGPUB;<br>USPAT; USOCR;<br>FPRS; EPO; JPO;<br>DERWENT;<br>IBM_TDB | OR               | ON      | 2020/05/20<br>19:33 |
| L5    | 1      | 3 and (geographic and location and map\$5 and flag and state and track\$5 and permit and prohibit)   | US-PGPUB;<br>USPAT; USOCR;<br>FPRS; EPO; JPO;<br>DERWENT;<br>IBM_TDB | OR               | ON      | 2020/05/20<br>19:34 |
| L6    | 8192   | 1 and @ad<"20011004"   | US-PGPUB;<br>USPAT; USOCR;<br>FPRS; EPO; JPO;<br>DERWENT;<br>IBM_TDB | OR               | ON      | 2020/05/20<br>19:35 |
| L7    | 162    | 6 and ((location or position) same (device or mobile or wtru or station or ue or (user adj equipment) or phone or apparatus) same map\$3 same stor\$4) | US-PGPUB;<br>USPAT; USOCR;<br>FPRS; EPO; JPO;<br>DERWENT;<br>IBM_TDB | OR               | ON      | 2020/05/20<br>19:41 |

|     |         |  |  |    |    |                     |
|-----|---------|--|--|----|----|---------------------|
| L8  | 0       | 7 and (navigat\$5 same information same number same segment same value same expected same time same travel)        | US-PGPUB;<br>USPAT; USOCR;<br>FPRS; EPO; JPO;<br>DERWENT;<br>IBM_TDB | OR | ON | 2020/05/20<br>19:43 |
| L9  | 0       | 7 and (set\$4 same flag same preference same (location or position) same track\$4 same permit\$5 same prohibit\$4) | US-PGPUB;<br>USPAT; USOCR;<br>FPRS; EPO; JPO;<br>DERWENT;<br>IBM_TDB | OR | ON | 2020/05/20<br>19:45 |
| L10 | 1       | 6 and (set\$4 same flag same preference same (location or position) same track\$4 same permit\$5 same prohibit\$4) | US-PGPUB;<br>USPAT; USOCR;<br>FPRS; EPO; JPO;<br>DERWENT;<br>IBM_TDB | OR | ON | 2020/05/20<br>19:45 |
| L11 | 0       | 10 and (navigat\$5 same information same number same segment same value same expected same time same travel)       | US-PGPUB;<br>USPAT; USOCR;<br>FPRS; EPO; JPO;<br>DERWENT;<br>IBM_TDB | OR | ON | 2020/05/20<br>19:47 |
| L12 | 1691811 | (H04W\$/\$.CPC.  | US-PGPUB;<br>USPAT; USOCR;<br>FPRS; EPO; JPO;<br>DERWENT;<br>IBM_TDB | OR | ON | 2020/05/20<br>19:49 |
| L13 | 955752  | (H04B\$/\$.CPC.  | US-PGPUB;<br>USPAT; USOCR;<br>FPRS; EPO; JPO;<br>DERWENT;<br>IBM_TDB | OR | ON | 2020/05/20<br>19:50 |
| L14 | 502699  | (G01S\$/\$.CPC.  | US-PGPUB;<br>USPAT; USOCR;<br>FPRS; EPO; JPO;<br>DERWENT;<br>IBM_TDB | OR | ON | 2020/05/20<br>19:50 |
| L15 | 2821006 | 12 OR 13 OR 14   | US-PGPUB;<br>USPAT; USOCR;<br>FPRS; EPO; JPO;<br>DERWENT;<br>IBM_TDB | OR | ON | 2020/05/20<br>19:51 |

|     |        |  |  |    |    |                     |
|-----|--------|--|--|----|----|---------------------|
| L16 | 525281 | 15 and @ad<"20011004"  | US-PGPUB;<br>USPAT; USOCR;<br>FPRS; EPO; JPO;<br>DERWENT;<br>IBM_TDB | OR | ON | 2020/05/20<br>19:51 |
| L17 | 1238   | 16 and ((location or position) same (device or mobile or wtru or station or ue or (user adj equipment) or phone or apparatus) same map\$3 same stor\$4)  | US-PGPUB;<br>USPAT; USOCR;<br>FPRS; EPO; JPO;<br>DERWENT;<br>IBM_TDB | OR | ON | 2020/05/20<br>19:52 |
| L18 | 0      | 17 and (navigat\$5 same information same number same segment same value same expected same time same travel)   | US-PGPUB;<br>USPAT; USOCR;<br>FPRS; EPO; JPO;<br>DERWENT;<br>IBM_TDB | OR | ON | 2020/05/20<br>19:53 |
| L19 | 0      | 17 and (set\$4 same flag same preference same (location or position) same track\$4 same permit\$5 same prohibit\$4)  | US-PGPUB;<br>USPAT; USOCR;<br>FPRS; EPO; JPO;<br>DERWENT;<br>IBM_TDB | OR | ON | 2020/05/20<br>19:54 |
| L20 | 1      | 16 and (set\$4 same flag same preference same (location or position) same track\$4 same permit\$5 same prohibit\$4)  | US-PGPUB;<br>USPAT; USOCR;<br>FPRS; EPO; JPO;<br>DERWENT;<br>IBM_TDB | OR | ON | 2020/05/20<br>19:54 |
| L21 | 0      | 20 and (navigat\$5 same information same number same segment same value same expected same time same travel)   | US-PGPUB;<br>USPAT; USOCR;<br>FPRS; EPO; JPO;<br>DERWENT;<br>IBM_TDB | OR | ON | 2020/05/20<br>19:56 |
| L22 | 59     | 16 and ((location or position) same (device or mobile or wtru or station or ue or (user adj equipment) or phone or apparatus) same map\$3 same stor\$4 same user same navigation same information) | US-PGPUB;<br>USPAT; USOCR;<br>FPRS; EPO; JPO;<br>DERWENT;<br>IBM_TDB | OR | ON | 2020/05/20<br>19:59 |
| L23 | 0      | 22 and (traffic same congestion same navigation same information same segment same travel same update)   | US-PGPUB;<br>USPAT; USOCR;<br>FPRS; EPO; JPO;<br>DERWENT;<br>IBM_TDB | OR | ON | 2020/05/20<br>20:01 |

|     |   |  |  |    |    |                  |
|-----|---|--|--|----|----|------------------|
| L24 | 0 | 22 and ((location or position) same (device or mobile or wtru or station or ue or (user adj equipment) or phone or apparatus) same preference same flag same track\$5 same set\$4) | US-PGPUB; USPAT; USOCR; FPRS; EPO; JPO; DERWENT; IBM_TDB | OR | ON | 2020/05/20 20:03 |
|-----|---|--|--|----|----|------------------|

#### EAST Search History (Interference)

| Ref # | Hits | Search Query   | DBs             | Default Operator | Plurals | Time Stamp       |
|-------|------|--|-----------------|------------------|---------|------------------|
| L25   | 2667 | (generat\$4 same location same map\$4 same information same stor\$4).clm.  | US-PGPUB; USPAT | OR               | ON      | 2020/05/20 20:05 |
| L26   | 105  | (geographic same information same location same display same destination).clm.   | US-PGPUB; USPAT | OR               | ON      | 2020/05/20 20:07 |
| L27   | 2    | (navigation same information same traffic same congestion same travel same segment same update same numerical same value).clm. | US-PGPUB; USPAT | OR               | ON      | 2020/05/20 20:09 |
| L28   | 1    | (set\$4 same location same preference same flag same permit same prohibit).clm.  | US-PGPUB; USPAT | OR               | ON      | 2020/05/20 20:10 |
| L29   | 1    | 25 and 26 and 27 and 28  | US-PGPUB; USPAT | OR               | ON      | 2020/05/20 20:11 |

5/20/2020 8:11:59 PM



1.28C  
128

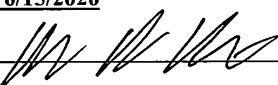


IN THE UNITED STATES PATENT AND TRADEMARK OFFICE

|  |            |                          |  |
|--|------------|--------------------------|--|
| Applicant(s): Reed   |            |                          |  |
| Application No.: 16/788,498  |            | Art Unit:<br>2416        |  |
| Filed:<br>02/12/2020   | 02/12/2020 | Examiner:<br>Patel, Ajit |  |
| Title: MOBILE WIRELESS DEVICE PROVIDING<br>OFF-LINE AND ON-LINE GEOGRAPHIC<br>NAVIGATION INFORMATION |            |                          |  |
| Attorney Docket No.: TX1000-C12  |            |                          |  |

USPTO  
RECEIPTS ACCOUNTING  
DIVISION  
2020 JUN 23 PM 2: 52

I hereby certify that this correspondence is being deposited with the United States Postal Service with sufficient postage as first class mail in an envelope addressed to "Commissioner for Patents, PO BOX 1450, Alexandria, VA 22313-1450" on 6/15/2020

Signature 

Typed or printed name : Andrew Mitchell Harris

Commissioner for Patents  
P.O. Box 1450  
Alexandria, VA 22313-1450

Mitch Harris, Atty at Law, LLC  
PO Box 1269  
Athens, GA 30603-1269

**FEE DEFICIENCY SUBMISSION UNDER 37 CFR §1.28(c)**

Dear Sir:

The Fees itemized in the Table below were erroneously paid in good faith at the small entity discounted rate, but should have been paid at the undiscounted rate due to a change in entity status. Please charge the total fee deficiency recited in the Table below to the credit card specified on the attached PTO-2038 Credit Card Payment Form.

| Fee Type                     | Large Entity Fee | Amount Paid | Date Paid | Amount Due |
|------------------------------|------------------|-------------|-----------|------------|
| surcharge                    | \$160            | \$80        | 2/12/2020 | \$80       |
| exam fee                     | \$760            | \$380       | 2/12/2020 | \$380      |
| basic filing fee             | \$300            | \$75        | 2/12/2020 | \$225      |
| Size fee                     | \$1,200          | \$600       | 2/12/2020 | \$600      |
| extra total claims           | \$1,000          | \$500       | 2/12/2020 | \$500      |
| Search Fee                   | \$660            | \$330       | 2/12/2020 | \$330      |
| Track I request              | \$4,000          | \$2,000     | 2/12/2020 | \$2,000    |
| processing fee               | \$140            | \$70        | 2/12/2020 | \$70       |
| TOTAL FEE DEFICIENCY: \$4185 |                  |             |           |            |

No additional fees should be incurred by this Letter, but if there are any fees incurred by this Letter, please deduct them from Deposit Account NO. 50-3808.

Respectfully Submitted,

  
 Andrew Mitchell Harris  
 Attorney/Agent for Applicant(s)  
 Reg. No. 42638

Mitch Harris, Atty at Law, L.L.C.  
 P.O. Box 1269  
 Athens, GA 30603-1269  
 Tel. 866-553-4918



# United States Patent and Trademark Office

*Office of the Chief Financial Officer*

Document Code:WFEE

User :67142

Sale Accounting Date:06/25/2020

---

| Sale Item Reference Number | Effective Date |
|----------------------------|----------------|
| 16788498                   | 06/15/2020     |

| Document Number  | Fee Code | Fee Code Description                      | Amount Paid | Payment Method |
|------------------|----------|---|-------------|----------------|
| I20206OE53172604 | 1599     | MAINTENANCE/PETITION<br>INTERNAL FEE CODE | \$4,185.00  | Credit Card    |

Under the Paperwork Reduction Act of 1995, no persons are required to respond to a collection of information unless it displays a valid OMB control number.

| Substitute for form 1449A/PTO<br><br><b>INFORMATION DISCLOSURE STATEMENT BY APPLICANT</b><br><br><i>(Use as many sheets as necessary)</i> | <table border="1" style="width: 100%; border-collapse: collapse;"> <tr> <th colspan="2" style="text-align: center;"><i>Complete if Known</i></th> </tr> <tr> <td style="padding: 2px;">Application Number</td> <td style="padding: 2px;">16/788,498</td> </tr> <tr> <td style="padding: 2px;">Filing Date</td> <td style="padding: 2px;">2/12/2020</td> </tr> <tr> <td style="padding: 2px;">First Named Inventor</td> <td style="padding: 2px;">Reed et al.</td> </tr> <tr> <td style="padding: 2px;">Art Unit</td> <td style="padding: 2px;">2416</td> </tr> <tr> <td style="padding: 2px;">Examiner Name</td> <td style="padding: 2px;">Patel, Ajit</td> </tr> <tr> <td style="padding: 2px;">Attorney Docket Number</td> <td style="padding: 2px;">TX1000-C12</td> </tr> </table> | <i>Complete if Known</i> |   | Application Number | 16/788,498 | Filing Date | 2/12/2020 | First Named Inventor | Reed et al. | Art Unit | 2416 | Examiner Name | Patel, Ajit | Attorney Docket Number | TX1000-C12 |
|---|---|--------------------------|---|--------------------|------------|-------------|-----------|----------------------|-------------|----------|------|---------------|-------------|------------------------|------------|
| <i>Complete if Known</i>  |   |                          |   |                    |            |             |           |                      |             |          |      |               |             |                        |            |
| Application Number  | 16/788,498  |                          |   |                    |            |             |           |                      |             |          |      |               |             |                        |            |
| Filing Date   | 2/12/2020   |                          |   |                    |            |             |           |                      |             |          |      |               |             |                        |            |
| First Named Inventor  | Reed et al.   |                          |   |                    |            |             |           |                      |             |          |      |               |             |                        |            |
| Art Unit  | 2416  |                          |   |                    |            |             |           |                      |             |          |      |               |             |                        |            |
| Examiner Name   | Patel, Ajit   |                          |   |                    |            |             |           |                      |             |          |      |               |             |                        |            |
| Attorney Docket Number  | TX1000-C12  |                          |   |                    |            |             |           |                      |             |          |      |               |             |                        |            |
| Sheet   | 1   | of                       | 2 |                    |            |             |           |                      |             |          |      |               |             |                        |            |

| U.S. PATENT DOCUMENTS |                       |   |                                |   |   |
|-----------------------|-----------------------|---|--------------------------------|---|---|
| Examiner Initials*    | Cite No. <sup>1</sup> | Document Number                                   | Publication Date<br>MM-DD-YYYY | Name of Patentee or Applicant of Cited Document | Pages, Columns, Lines, Where Relevant Passages or Relevant Figures Appear |
|                       |                       | Number - Kind Code <sup>2</sup> <i>(if known)</i> |                                |   |   |
|                       |                       | US-5,625,668                                      | 04-29-1997                     | Loomis, et al.                                  |   |
|                       |                       | US-   |                                |   |   |
|                       |                       | US-   |                                |   |   |
|                       |                       | US-   |                                |   |   |
|                       |                       | US-   |                                |   |   |
|                       |                       | US-   |                                |   |   |
|                       |                       | US-   |                                |   |   |
|                       |                       | US-   |                                |   |   |
|                       |                       | US-   |                                |   |   |
|                       |                       | US-   |                                |   |   |
|                       |                       | US-   |                                |   |   |
|                       |                       | US-   |                                |   |   |
|                       |                       | US-   |                                |   |   |
|                       |                       | US-   |                                |   |   |
|                       |                       | US-   |                                |   |   |
|                       |                       | US-   |                                |   |   |
|                       |                       | US-   |                                |   |   |
|                       |                       | US-   |                                |   |   |
|                       |                       | US-   |                                |   |   |
|                       |                       | US-   |                                |   |   |

| FOREIGN PATENT DOCUMENTS |                       |  |                                |   |   |                |
|--------------------------|-----------------------|--|--------------------------------|---|---|----------------|
| Examiner Initials*       | Cite No. <sup>1</sup> | Foreign Patent Document  | Publication Date<br>MM-DD-YYYY | Name of Patentee or Applicant of Cited Document | Pages, Columns, Lines, Where Relevant Passages or Relevant Figures Appear | T <sup>6</sup> |
|                          |                       | Country Code <sup>3</sup> - Number <sup>4</sup> - Kind Code <sup>5</sup> <i>(if known)</i> |                                |   |   |                |
|                          |                       |  |                                |   |   |                |
|                          |                       |  |                                |   |   |                |
|                          |                       |  |                                |   |   |                |
|                          |                       |  |                                |   |   |                |
|                          |                       |  |                                |   |   |                |
|                          |                       |  |                                |   |   |                |
|                          |                       |  |                                |   |   |                |
|                          |                       |  |                                |   |   |                |
|                          |                       |  |                                |   |   |                |
|                          |                       |  |                                |   |   |                |
|                          |                       |  |                                |   |   |                |
|                          |                       |  |                                |   |   |                |
|                          |                       |  |                                |   |   |                |
|                          |                       |  |                                |   |   |                |
|                          |                       |  |                                |   |   |                |
|                          |                       |  |                                |   |   |                |
|                          |                       |  |                                |   |   |                |
|                          |                       |  |                                |   |   |                |
|                          |                       |  |                                |   |   |                |

|                    |                 |
|--------------------|-----------------|
| Examiner Signature | Date Considered |
|--------------------|-----------------|

\*EXAMINER: Initial if reference considered, whether or not citation is in conformance with MPEP 609. Draw line through citation if not in conformance and not considered. Include copy of this form with next communication to applicant. <sup>1</sup>Applicant's unique citation designation number (optional). <sup>2</sup>See Kinds Codes of USPTO Patent Documents at [www.uspto.gov](http://www.uspto.gov) or MPEP 901.04. <sup>3</sup>Enter Office that issued the document, by the two-letter code (WIPO Standard ST.3). <sup>4</sup>For Japanese patent documents, the indication of the year of the reign of the Emperor must precede the serial number of the patent document. <sup>5</sup>Kind of document by the appropriate symbols as indicated on the document under WIPO Standard ST. 16 if possible. <sup>6</sup>Applicant is to place a check mark here if English language Translation is attached.

This collection of information is required by 37 CFR 1.97 and 1.98. The information is required to obtain or retain a benefit by the public which is to file (and by the USPTO to process) an application. Confidentiality is governed by 35 U.S.C. 122 and 37 CFR 1.14. This collection is estimated to take 2 hours to complete, including gathering, preparing, and submitting the completed application form to the USPTO. Time will vary depending upon the individual case. Any comments on the amount of time you require to complete this form and/or suggestions for reducing this burden, should be sent to the Chief Information Officer, U.S. Patent and Trademark Office, U.S. Department of Commerce, P.O. Box 1450, Alexandria, VA 22313-1450. DO NOT SEND FEES OR COMPLETED FORMS TO THIS ADDRESS. SEND TO: Commissioner for Patents, P.O. Box 1450, Alexandria, VA 22313-1450.

If you need assistance in completing the form, call 1-800-PTO-9199 (1-800-786-9199) and select option 2.

Under the Paperwork Reduction Act of 1995, no persons are required to respond to a collection of information unless it displays a valid OMB control number.

|  |   |    |                             |             |
|--|---|----|-----------------------------|-------------|
| Substitute for form 1449B/PTO                            |   |    | <b>Complete if Known</b>    |             |
|  |   |    | <b>Application Number</b>   | 16/788,498  |
| <b>INFORMATION DISCLOSURE<br/>STATEMENT BY APPLICANT</b> |   |    | <b>Filing Date</b>          | 2/12/2020   |
|  |   |    | <b>First Named Inventor</b> | Reed et al. |
|  |   |    | Art Unit                    | 2416        |
|  |   |    | Examiner Name               | Patel, Ajit |
|  |   |    | Attorney Docket Number      | TX1000-C12  |
| <i>(Use as many sheets as necessary)</i>                 |   |    |                             |             |
| Sheet  | 2 | of | 2                           |             |

| NON PATENT LITERATURE DOCUMENTS |                       |   |                |
|---------------------------------|-----------------------|---|----------------|
| Examiner Initials*              | Cite No. <sup>1</sup> | Include name of the author (in CAPITAL LETTERS), title of the article (when appropriate), title of the item (book, magazine, journal, serial, symposium, catalog, etc.), date, page(s), volume-issue number(s), publisher, city and/or country where published. | T <sup>2</sup> |
|                                 |                       | Notice of Allowance in 16/557,277 mailed on 05/13/2020, 54 pages (pp. 1-54 in pdf).   |                |
|                                 |                       | Notice of Allowance in 16/557,277 mailed on 06/08/2020, 12 pages (pp. 1-12 in pdf).   |                |
|                                 |                       | Notice of Allowance in 16/779,590 mailed on 05/14/2020, 48 pages (pp. 1-48 in pdf).   |                |
|                                 |                       |   |                |
|                                 |                       |   |                |
|                                 |                       |   |                |
|                                 |                       |   |                |
|                                 |                       |   |                |
|                                 |                       |   |                |
|                                 |                       |   |                |
|                                 |                       |   |                |
|                                 |                       |   |                |
|                                 |                       |   |                |
|                                 |                       |   |                |
|                                 |                       |   |                |
|                                 |                       |   |                |

|                    |                 |
|--------------------|-----------------|
| Examiner Signature | Date Considered |
|--------------------|-----------------|

\*EXAMINER: Initial if reference considered, whether or not citation is in conformance with MPEP 609. Draw line through citation if not in conformance and not considered. Include copy of this form with next communication to applicant.

<sup>1</sup>Applicant's unique citation designation number (optional). <sup>2</sup>Applicant is to place a check mark here if English language Translation is attached. This collection of information is required by 37 CFR 1.98. The information is required to obtain or retain a benefit by the public which is to file (and by the USPTO to process) an application. Confidentiality is governed by 35 U.S.C. 122 and 37 CFR 1.14. This collection is estimated to take 2 hours to complete, including gathering, preparing, and submitting the completed application form to the USPTO. Time will vary depending upon the individual case. Any comments on the amount of time you require to complete this form and/or suggestions for reducing this burden, should be sent to the Chief Information Officer, U.S. Patent and Trademark Office, U.S. Department of Commerce, P.O. Box 1450, Alexandria, VA 22313-1450. DO NOT SEND FEES OR COMPLETED FORMS TO THIS ADDRESS. SEND TO: Commissioner for Patents, P.O. Box 1450, Alexandria, VA 22313-1450.

*If you need assistance in completing the form, call 1-800-PTO-9199 (1-800-786-9199) and select option 2.*

## Electronic Patent Application Fee Transmittal

|  |   |                 |               |                             |
|--|---|-----------------|---------------|-----------------------------|
| <b>Application Number:</b>                         | 16788498  |                 |               |                             |
| <b>Filing Date:</b>                                | 12-Feb-2020   |                 |               |                             |
| <b>Title of Invention:</b>                         | MOBILE WIRELESS DEVICE PROVIDING OFF-LINE AND ON-LINE GEOGRAPHIC NAVIGATION INFORMATION |                 |               |                             |
| <b>First Named Inventor/Applicant Name:</b>        | Mark Jefferson Reed   |                 |               |                             |
| <b>Filer:</b>                                      | Andrew Mitchell Harris  |                 |               |                             |
| <b>Attorney Docket Number:</b>                     | TX1000-C12  |                 |               |                             |
| Filed as Large Entity                              |   |                 |               |                             |
| <b>Filing Fees for Utility under 35 USC 111(a)</b> |   |                 |               |                             |
| <b>Description</b>                                 | <b>Fee Code</b>   | <b>Quantity</b> | <b>Amount</b> | <b>Sub-Total in USD(\$)</b> |
| <b>Basic Filing:</b>                               |   |                 |               |                             |
| <b>Pages:</b>                                      |   |                 |               |                             |
| <b>Claims:</b>                                     |   |                 |               |                             |
| <b>Miscellaneous-Filing:</b>                       |   |                 |               |                             |
| <b>Petition:</b>                                   |   |                 |               |                             |
| <b>Patent-Appeals-and-Interference:</b>            |   |                 |               |                             |
| <b>Post-Allowance-and-Post-Issuance:</b>           |   |                 |               |                             |
| <b>Extension-of-Time:</b>                          |   |                 |               |                             |

| Description                             | Fee Code | Quantity | Amount | Sub-Total in USD(\$) |
|---|----------|----------|--------|----------------------|
| <b>Miscellaneous:</b>                   |          |          |        |                      |
| SUBMISSION- INFORMATION DISCLOSURE STMT | 1806     | 1        | 240    | 240                  |
| <b>Total in USD (\$)</b>                |          |          |        | <b>240</b>           |

## Electronic Acknowledgement Receipt

|   |   |
|---|---|
| <b>EFS ID:</b>                              | 39843743  |
| <b>Application Number:</b>                  | 16788498  |
| <b>International Application Number:</b>    |   |
| <b>Confirmation Number:</b>                 | 8054  |
| <b>Title of Invention:</b>                  | MOBILE WIRELESS DEVICE PROVIDING OFF-LINE AND ON-LINE GEOGRAPHIC NAVIGATION INFORMATION |
| <b>First Named Inventor/Applicant Name:</b> | Mark Jefferson Reed   |
| <b>Customer Number:</b>                     | 59911   |
| <b>Filer:</b>                               | Andrew Mitchell Harris  |
| <b>Filer Authorized By:</b>                 |   |
| <b>Attorney Docket Number:</b>              | TX1000-C12  |
| <b>Receipt Date:</b>                        | 26-JUN-2020   |
| <b>Filing Date:</b>                         | 12-FEB-2020   |
| <b>Time Stamp:</b>                          | 16:51:56  |
| <b>Application Type:</b>                    | Utility under 35 USC 111(a)   |

### Payment information:

|  |                  |
|--|------------------|
| Submitted with Payment                   | yes              |
| Payment Type                             | CARD             |
| Payment was successfully received in RAM | \$240            |
| RAM confirmation Number                  | E20206PG54161570 |
| Deposit Account                          |                  |
| Authorized User                          |                  |

The Director of the USPTO is hereby authorized to charge indicated fees and credit any overpayment as follows:



| <b>File Listing:</b>   |  |   |   |                         |                         |
|------------------------|--|---|---|-------------------------|-------------------------|
| <b>Document Number</b> | <b>Document Description</b>                                | <b>File Name</b>                          | <b>File Size(Bytes)/<br/>Message Digest</b> | <b>Multi Part /.zip</b> | <b>Pages (if appl.)</b> |
| 1                      | Other Reference-Patent/App/Search documents                | TX1000-C10_NoticeOfAllowance_05-13-20.pdf | 2784985                                     | no                      | 54                      |
|                        |  |   | 2922b84cabb01ca3d16142bb9b4e660c6a49916b    |                         |                         |
| <b>Warnings:</b>       |  |   |   |                         |                         |
| <b>Information:</b>    |  |   |   |                         |                         |
| 2                      | Other Reference-Patent/App/Search documents                | TX1000-C10_NoticeOfAllowance_06-08-20.pdf | 518660                                      | no                      | 12                      |
|                        |  |   | 9b025276ba5936a3c4f5c8744937cf16eb84f229    |                         |                         |
| <b>Warnings:</b>       |  |   |   |                         |                         |
| <b>Information:</b>    |  |   |   |                         |                         |
| 3                      | Other Reference-Patent/App/Search documents                | TX1000-C11_NoticeOfAllowance_05-14-20.pdf | 2485844                                     | no                      | 48                      |
|                        |  |   | 96c99ea3ede6521a7d3a4e703a385046d41c425a    |                         |                         |
| <b>Warnings:</b>       |  |   |   |                         |                         |
| <b>Information:</b>    |  |   |   |                         |                         |
| 4                      |  | TX1000-C12_IDS_06-26-20.pdf               | 265950                                      | yes                     | 4                       |
|                        |  |   | 378b68e5fa77ba0bb2e5eba22c69aeb553757509    |                         |                         |
|                        | <b>Multipart Description/PDF files in .zip description</b> |   |   |                         |                         |
|                        | <b>Document Description</b>                                |   | <b>Start</b>                                | <b>End</b>              |                         |
|                        | Transmittal Letter   |   | 1   | 2                       |                         |
|                        | Information Disclosure Statement (IDS) Form (SB08)         |   | 3   | 4                       |                         |
| <b>Warnings:</b>       |  |   |   |                         |                         |
| <b>Information:</b>    |  |   |   |                         |                         |
| 5                      | Fee Worksheet (SB06)                                       | fee-info.pdf                              | 30707                                       | no                      | 2                       |
|                        |  |   | 5b43bc1f8008a9fc10297f46b1969590395945d7    |                         |                         |
| <b>Warnings:</b>       |  |   |   |                         |                         |
| <b>Information:</b>    |  |   |   |                         |                         |

This Acknowledgement Receipt evidences receipt on the noted date by the USPTO of the indicated documents, characterized by the applicant, and including page counts, where applicable. It serves as evidence of receipt similar to a Post Card, as described in MPEP 503.

**New Applications Under 35 U.S.C. 111**

If a new application is being filed and the application includes the necessary components for a filing date (see 37 CFR 1.53(b)-(d) and MPEP 506), a Filing Receipt (37 CFR 1.54) will be issued in due course and the date shown on this Acknowledgement Receipt will establish the filing date of the application.

**National Stage of an International Application under 35 U.S.C. 371**

If a timely submission to enter the national stage of an international application is compliant with the conditions of 35 U.S.C. 371 and other applicable requirements a Form PCT/DO/EO/903 indicating acceptance of the application as a national stage submission under 35 U.S.C. 371 will be issued in addition to the Filing Receipt, in due course.

**New International Application Filed with the USPTO as a Receiving Office**

If a new international application is being filed and the international application includes the necessary components for an international filing date (see PCT Article 11 and MPEP 1810), a Notification of the International Application Number and of the International Filing Date (Form PCT/RO/105) will be issued in due course, subject to prescriptions concerning national security, and the date shown on this Acknowledgement Receipt will establish the international filing date of the application.

IN THE UNITED STATES PATENT AND TRADEMARK OFFICE

|  |                          |
|--|--------------------------|
| Applicant(s): Reed et al.  |                          |
| Serial No.: 16/557,277   |                          |
| Filed: 8/30/2019   | Group Art Unit:<br>2416  |
| Title: WIRELESS NETWORK AND<br>METHOD FOR SUGGESTING<br>CORRECTIVE ACTION IN RESPONSE<br>TO DETECTING COMMUNICATIONS<br>ERRORS | Examiner:<br>PATEL, AJIT |
| Attorney Docket No.: TX1000-C10  |                          |

Commissioner for Patents  
P.O. Box 1450  
Alexandria, VA 22313-1450

**INFORMATION DISCLOSURE STATEMENT**

Dear Sir:

This Information Disclosure Statement is submitted:

- under 37 CFR 1.97(b), or  
(Within three months of filing national application; or date of entry of international application;  
or before mailing date of first office action on the merits; whichever occurs last)
- under 37 CFR 1.97(c) together with either a:
  - Statement under 37 CFR 1.97(e), or
  - a \$240.00 fee under 37 CFR 1.17(p), or(After the CFR 1.97(b) time period, but before final action or notice of allowance,  
whichever occurs first)
- under 37 CFR 1.97(d) together with a:
  - Statement under 37 CFR 1.97(e), and
  - a \$240.00 fee set forth in 37 CFR 1.17(p).(Filed after final action or notice of allowance, whichever occurs first, but before payment  
of the issue fee)

Applicant(s) submit herewith Form PTO 1449-Information Disclosure Citation together with  
copies, of patents, publications or other information of which applicant(s) are aware, which applicant(s)  
believe(s) may be material to the examination of this application and for which there may be a duty to  
disclose in accordance with 37 CFR 1.56.

The undersigned certifies that this IDS is being submitted under 37 C.F.R. 1.97(d) after the mailing of a  
Final Office Action, Notice of Allowance or other action closing prosecution in the application, and:

(1) That each item of information contained in the information disclosure statement was first cited in any communication from a foreign patent office in a counterpart foreign application not more than three months prior to the filing of the information disclosure statement; or

(2) That no item of information contained in the information disclosure statement was cited in a communication from a foreign patent office in a counterpart foreign application, and, to the knowledge of the person signing the certification after making reasonable inquiry, no item of information contained in the information disclosure statement was known to any individual designated in § 1.56(c) more than three months prior to the filing of the information disclosure statement.

While this Information Disclosure Statement may be "material" pursuant to 37 C.F.R. 1.56, it is not intended to constitute an admission that any patent, publication or other information referred to herein is "prior art" for this invention unless specifically designated as such.

In accordance with 37 C.F.R. 1.97(g) the filing of this Information Disclosure Statement shall not be construed to mean that a search has been made or that no other material information as defined in 37 CFR 1.56 (b) exists.

Any fee required above for the submission of this IDS has been paid via EFS-WEB. However, in the event that another fee is required in connection with the enclosed Information Disclosure Statement, the Commissioner of Patents and Trademarks is authorized to charge Deposit Account No. 50-3808 for the necessary amount.

It is requested that the information disclosed herein be made of record in this application.

Respectfully submitted,

/Andrew Mitchell Harris #42,638/

Andrew Mitchell Harris  
Attorney/Agent for Applicant(s)  
Reg. No. 42638

Date: June 26, 2020

Telephone No.: 866-553-4918



UNITED STATES PATENT AND TRADEMARK OFFICE

UNITED STATES DEPARTMENT OF COMMERCE
United States Patent and Trademark Office
Address: COMMISSIONER FOR PATENTS
P.O. Box 1450
Alexandria, Virginia 22313-1450
www.uspto.gov

Table with 5 columns: APPLICATION NO., FILING DATE, FIRST NAMED INVENTOR, ATTORNEY DOCKET NO., CONFIRMATION NO.
Row 1: 16/788,498, 02/12/2020, Mark Jefferson Reed, TX1000-C12, 8054
Row 2: 59911, 7590, 07/02/2020, MITCH HARRIS, LLC - GENERAL, P.O. BOX 1269, ATHENS, GA 30603-1269
Row 3: EXAMINER, PATEL, AJIT
Row 4: ART UNIT, PAPER NUMBER, 2416
Row 5: MAIL DATE, DELIVERY MODE, 07/02/2020, PAPER

Please find below and/or attached an Office communication concerning this application or proceeding.

The time period for reply, if any, is set in the attached communication.

**CORRECTED**  
**Notice of Allowability**

**Application No.**  
16/788,498

**Applicant(s)**  
Reed et al.

**Examiner**  
AJIT PATEL

**Art Unit**  
2416

**AIA (FITF) Status**  
No

**-- The MAILING DATE of this communication appears on the cover sheet with the correspondence address--**

All claims being allowable, PROSECUTION ON THE MERITS IS (OR REMAINS) CLOSED in this application. If not included herewith (or previously mailed), a Notice of Allowance (PTOL-85) or other appropriate communication will be mailed in due course. **THIS NOTICE OF ALLOWABILITY IS NOT A GRANT OF PATENT RIGHTS.** This application is subject to withdrawal from issue at the initiative of the Office or upon petition by the applicant. See 37 CFR 1.313 and MPEP 1308.

1.  This communication is responsive to IDS filed on 6/26/20.  
 A declaration(s)/affidavit(s) under **37 CFR 1.130(b)** was/were filed on \_\_\_\_\_.
2.  An election was made by the applicant in response to a restriction requirement set forth during the interview on \_\_\_\_\_; the restriction requirement and election have been incorporated into this action.
3.  The allowed claim(s) is/are See Continuation Sheet. As a result of the allowed claim(s), you may be eligible to benefit from the **Patent Prosecution Highway** program at a participating intellectual property office for the corresponding application. For more information, please see [http://www.uspto.gov/patents/init\\_events/pph/index.jsp](http://www.uspto.gov/patents/init_events/pph/index.jsp) or send an inquiry to [PPHfeedback@uspto.gov](mailto:PPHfeedback@uspto.gov).
4.  Acknowledgment is made of a claim for foreign priority under 35 U.S.C. § 119(a)-(d) or (f).

**Certified copies:**

- a)  All    b)  Some    \*c)  None of the:
1.  Certified copies of the priority documents have been received.
  2.  Certified copies of the priority documents have been received in Application No. \_\_\_\_\_.
  3.  Copies of the certified copies of the priority documents have been received in this national stage application from the International Bureau (PCT Rule 17.2(a)).

\* Certified copies not received: \_\_\_\_\_.

Applicant has THREE MONTHS FROM THE "MAILING DATE" of this communication to file a reply complying with the requirements noted below. Failure to timely comply will result in ABANDONMENT of this application.

**THIS THREE-MONTH PERIOD IS NOT EXTENDABLE.**


5.  CORRECTED DRAWINGS (as "replacement sheets") must be submitted.  
 including changes required by the attached Examiner's Amendment / Comment or in the Office action of Paper No./Mail Date \_\_\_\_\_.  
**Identifying indicia such as the application number (see 37 CFR 1.84(c)) should be written on the drawings in the front (not the back) of each sheet. Replacement sheet(s) should be labeled as such in the header according to 37 CFR 1.121(d).**
6.  DEPOSIT OF and/or INFORMATION about the deposit of BIOLOGICAL MATERIAL must be submitted. Note the attached Examiner's comment regarding REQUIREMENT FOR THE DEPOSIT OF BIOLOGICAL MATERIAL.

**Attachment(s)**

- |   |   |
|---|---|
| 1. <input type="checkbox"/> Notice of References Cited (PTO-892)  | 5. <input type="checkbox"/> Examiner's Amendment/Comment                  |
| 2. <input checked="" type="checkbox"/> Information Disclosure Statements (PTO/SB/08),<br>Paper No./Mail Date _____. | 6. <input type="checkbox"/> Examiner's Statement of Reasons for Allowance |
| 3. <input type="checkbox"/> Examiner's Comment Regarding Requirement for Deposit<br>of Biological Material _____.   | 7. <input type="checkbox"/> Other _____.                                  |
| 4. <input type="checkbox"/> Interview Summary (PTO-413),<br>Paper No./Mail Date _____.                              |   |

/AJIT PATEL/  
Primary Examiner, Art Unit 2416

Continuation of 3. The allowed claim(s) is/are: 1,3-6,9-18,20-21,23-27 and 29-30

|   |  |   |
|---|--|---|
| <b><i>Search Notes</i></b><br> | <b>Application/Control No.</b><br>16/788,498 | <b>Applicant(s)/Patent Under Reexamination</b><br>Reed et al. |
|   | <b>Examiner</b><br>AJIT PATEL                | <b>Art Unit</b><br>2416                                       |

|                        |             |                 |
|------------------------|-------------|-----------------|
| <b>CPC - Searched*</b> |             |                 |
| <b>Symbol</b>          | <b>Date</b> | <b>Examiner</b> |
|                        |             |                 |


|   |             |                 |
|---|-------------|-----------------|
| <b>CPC Combination Sets - Searched*</b> |             |                 |
| <b>Symbol</b>                           | <b>Date</b> | <b>Examiner</b> |
|   |             |                 |

|                                      |                 |             |                 |
|--------------------------------------|-----------------|-------------|-----------------|
| <b>US Classification - Searched*</b> |                 |             |                 |
| <b>Class</b>                         | <b>Subclass</b> | <b>Date</b> | <b>Examiner</b> |
|                                      |                 |             |                 |

\* See search history printout included with this form or the SEARCH NOTES box below to determine the scope of the search.

|  |  |
|--|--|
|  |  |
|--|--|



|  |  |   |
|--|--|---|
| <b>Search Notes</b><br> | <b>Application/Control No.</b><br>16/788,498 | <b>Applicant(s)/Patent Under Reexamination</b><br>Reed et al. |
|  | <b>Examiner</b><br>AJIT PATEL                | <b>Art Unit</b><br>2416                                       |

| <b>Search Notes</b>   |             |                 |
|---|-------------|-----------------|
| <b>Search Notes</b>   | <b>Date</b> | <b>Examiner</b> |
| IPR2019-00324 Reviewed Petition for Inter Partes Review of U.S.Patent No. 9,642,024.              | 05/07/2020  | AP              |
| IPR2019-00326 Reviewed Petition for Inter Partes Review of U.S.Patent No. 9,510,320.              | 05/07/2020  | AP              |
| IPR2019-00327 Reviewed Petition for Inter Partes Review of U.S.Patent No. 8,977,284.              | 05/07/2020  | AP              |
| Inventor name searched  | 05/20/2020  | AP              |
| H04W4/023;H04W64/006;H04W24/02;G01S5/0252;H04W4/029;H04W4/02;H04W8/02;H04B17/318-LIMITED SEARCHED | 05/20/2020  | AP              |
| (H04W\$/\$.CPC.-LIMITED SEARCHED  | 05/20/2020  | AP              |
| (H04B\$/\$.CPC.-LIMITED SEARCHED  | 05/20/2020  | AP              |
| (G01S\$/\$.CPC.-LIMITED SEARCHED  | 05/20/2020  | AP              |
| EAST  | 05/20/2020  | AP              |
| EAST  | 06/30/2020  | AP              |

| <b>Interference Search</b> |                                    |             |                 |
|----------------------------|------------------------------------|-------------|-----------------|
| <b>US Class/CPC Symbol</b> | <b>US Subclass/CPC Group</b>       | <b>Date</b> | <b>Examiner</b> |
|                            | See EAST for interference searched | 05/20/2020  | AP              |

|  |  |
|--|--|
|  |  |
|--|--|

**EAST Search History**

**EAST Search History (Prior Art)**

| <b>Ref #</b> | <b>Hits</b> | <b>Search Query</b> | <b>DBs</b> | <b>Default Operator</b> | <b>Plurals</b> | <b>Time Stamp</b> |
|--------------|-------------|---------------------|------------|-------------------------|----------------|-------------------|
| L1           | 1           | "5625668".PN.       | USPAT      | OR                      | ON             | 2020/06/29 22:59  |

6/29/2020 11:01:03 PM

PTO/SB/08a (07-09)  
 Approved for use through 11/30/2020. OMB 0651-0031  
 U.S. Patent and Trademark Office; U.S. DEPARTMENT OF COMMERCE  
 Under the Paperwork Reduction Act of 1995, no persons are required to respond to a collection of information unless it displays a valid OMB control number.

|  |   |                      |   |                          |            |
|--|---|----------------------|---|--------------------------|------------|
| Substitute for form 1449A/PTO  |   |                      |   | <b>Complete if Known</b> |            |
| <b>INFORMATION DISCLOSURE<br/>STATEMENT BY APPLICANT</b><br><br><i>(Use as many sheets as necessary)</i> |   | Application Number   |   | 16/788,498               |            |
|  |   | Filing Date          |   | 2/12/2020                |            |
|  |   | First Named Inventor |   | Reed et al.              |            |
|  |   | Art Unit             |   | 2416                     |            |
|  |   | Examiner Name        |   | Patel, Ajit              |            |
| Sheet  | 1 | of                   | 2 | Attorney Docket Number   | TX1000-C12 |

| U.S. PATENT DOCUMENTS |                       |  |                                |   |   |
|-----------------------|-----------------------|--|--------------------------------|---|---|
| Examiner Initials*    | Cite No. <sup>1</sup> | Document Number                            | Publication Date<br>MM-DD-YYYY | Name of Patentee or Applicant of Cited Document | Pages, Columns, Lines, Where Relevant Passages or Relevant Figures Appear |
|                       |                       | Number - Kind Code <sup>2</sup> (if known) |                                |   |   |
|                       |                       | US-5,625,668                               | 04-29-1997                     | Loomis, et al.                                  |   |
|                       |                       | US-  |                                |   |   |
|                       |                       | US-  |                                |   |   |
|                       |                       | US-  |                                |   |   |
|                       |                       | US-  |                                |   |   |
|                       |                       | US-  |                                |   |   |
|                       |                       | US-  |                                |   |   |
|                       |                       | US-  |                                |   |   |
|                       |                       | US-  |                                |   |   |
|                       |                       | US-  |                                |   |   |
|                       |                       | US-  |                                |   |   |
|                       |                       | US-  |                                |   |   |
|                       |                       | US-  |                                |   |   |
|                       |                       | US-  |                                |   |   |
|                       |                       | US-  |                                |   |   |
|                       |                       | US-  |                                |   |   |
|                       |                       | US-  |                                |   |   |
|                       |                       | US-  |                                |   |   |
|                       |                       | US-  |                                |   |   |
|                       |                       | US-  |                                |   |   |
|                       |                       | US-  |                                |   |   |

| FOREIGN PATENT DOCUMENTS |                       |   |                                |   |   |                |
|--------------------------|-----------------------|---|--------------------------------|---|---|----------------|
| Examiner Initials*       | Cite No. <sup>1</sup> | Foreign Patent Document   | Publication Date<br>MM-DD-YYYY | Name of Patentee or Applicant of Cited Document | Pages, Columns, Lines, Where Relevant Passages or Relevant Figures Appear | T <sup>6</sup> |
|                          |                       | Country Code <sup>3</sup> - Number <sup>4</sup> - Kind Code <sup>5</sup> (if known) |                                |   |   |                |
|                          |                       |   |                                |   |   |                |
|                          |                       |   |                                |   |   |                |
|                          |                       |   |                                |   |   |                |
|                          |                       |   |                                |   |   |                |
|                          |                       |   |                                |   |   |                |
|                          |                       |   |                                |   |   |                |
|                          |                       |   |                                |   |   |                |
|                          |                       |   |                                |   |   |                |
|                          |                       |   |                                |   |   |                |
|                          |                       |   |                                |   |   |                |
|                          |                       |   |                                |   |   |                |
|                          |                       |   |                                |   |   |                |

|                    |              |                 |            |
|--------------------|--------------|-----------------|------------|
| Examiner Signature | /AJIT PATEL/ | Date Considered | 06/30/2020 |
|--------------------|--------------|-----------------|------------|

\*EXAMINER: Initial if reference considered, whether or not citation is in conformance with MPEP 609. Draw line through citation if not in conformance and not considered. Include copy of this form with next communication to applicant. <sup>1</sup>Applicant's unique citation designation number (optional). <sup>2</sup>See Kinds Codes of USPTO Patent Documents at [www.uspto.gov](http://www.uspto.gov) or MPEP 901.04. <sup>3</sup>Enter Office that issued the document, by the two-letter code (WIPO Standard ST.3). <sup>4</sup>For Japanese patent documents, the indication of the year of the reign of the Emperor must precede the serial number of the patent document. <sup>5</sup>Kind of document by the appropriate symbols as indicated on the document under WIPO Standard ST. 16 if possible. <sup>6</sup>Applicant is to place a check mark here if English language Translation is attached.

This collection of information is required by 37 CFR 1.97 and 1.98. The information is required to obtain or retain a benefit by the public which is to file (and by the USPTO to process) an application. Confidentiality is governed by 35 U.S.C. 122 and 37 CFR 1.14. This collection is estimated to take 2 hours to complete, including gathering, preparing, and submitting the completed application form to the USPTO. Time will vary depending upon the individual case. Any comments on the amount of time you require to complete this form and/or suggestions for reducing this burden, should be sent to the Chief Information Officer, U.S. Patent and Trademark Office, U.S. Department of Commerce, P.O. Box 1450, Alexandria, VA 22313-1450. DO NOT SEND FEES OR COMPLETED FORMS TO THIS ADDRESS. SEND TO: Commissioner for Patents, P.O. Box 1450, Alexandria, VA 22313-1450.

If you need assistance in completing the form, call 1-800-PTO-9199 (1-800-786-9199) and select option 2.

ALL REFERENCES CONSIDERED EXCEPT WHERE LINED THROUGH. /A.P/

PTO/SB/08b (07-09)  
 Approved for use through 11/30/2020. OMB 0651-0031  
 U.S. Patent and Trademark Office; U.S. DEPARTMENT OF COMMERCE

Under the Paperwork Reduction Act of 1995, no persons are required to respond to a collection of information unless it displays a valid OMB control number.

|  |   |                               |             |
|--|---|-------------------------------|-------------|
| Substitute for form 1449B/PTO  |   | <b>Complete if Known</b>      |             |
| <b>INFORMATION DISCLOSURE STATEMENT BY APPLICANT</b><br><br><i>(Use as many sheets as necessary)</i> |   | <b>Application Number</b>     | 16/788,498  |
|  |   | <b>Filing Date</b>            | 2/12/2020   |
|  |   | <b>First Named Inventor</b>   | Reed et al. |
|  |   | <b>Art Unit</b>               | 2416        |
|  |   | <b>Examiner Name</b>          | Patel, Ajit |
|  |   | <b>Attorney Docket Number</b> | TX1000-C12  |
| <b>Sheet</b>   | 2 | <b>of</b>                     | 2           |

| NON PATENT LITERATURE DOCUMENTS |                       |   |                |
|---------------------------------|-----------------------|---|----------------|
| Examiner Initials*              | Cite No. <sup>1</sup> | Include name of the author (in CAPITAL LETTERS), title of the article (when appropriate), title of the item (book, magazine, journal, serial, symposium, catalog, etc.), date, page(s), volume-issue number(s), publisher, city and/or country where published. | T <sup>2</sup> |
|                                 |                       | Notice of Allowance in 16/557,277 mailed on 05/13/2020, 54 pages (pp. 1-54 in pdf).   |                |
|                                 |                       | Notice of Allowance in 16/557,277 mailed on 06/08/2020, 12 pages (pp. 1-12 in pdf).   |                |
|                                 |                       | Notice of Allowance in 16/779,590 mailed on 05/14/2020, 48 pages (pp. 1-48 in pdf).   |                |
|                                 |                       |   |                |
|                                 |                       |   |                |
|                                 |                       |   |                |
|                                 |                       |   |                |
|                                 |                       |   |                |
|                                 |                       |   |                |
|                                 |                       |   |                |
|                                 |                       |   |                |
|                                 |                       |   |                |
|                                 |                       |   |                |
|                                 |                       |   |                |
|                                 |                       |   |                |
|                                 |                       |   |                |
|                                 |                       |   |                |
|                                 |                       |   |                |
|                                 |                       |   |                |

|                           |              |                        |            |
|---------------------------|--------------|------------------------|------------|
| <b>Examiner Signature</b> | /AJIT PATEL/ | <b>Date Considered</b> | 06/30/2020 |
|---------------------------|--------------|------------------------|------------|

\*EXAMINER: Initial if reference considered, whether or not citation is in conformance with MPEP 609. Draw line through citation if not in conformance and not considered. Include copy of this form with next communication to applicant.  
<sup>1</sup>Applicant's unique citation designation number (optional). <sup>2</sup>Applicant is to place a check mark here if English language Translation is attached.  
 This collection of information is required by 37 CFR 1.98. The information is required to obtain or retain a benefit by the public which is to file (and by the USPTO to process) an application. Confidentiality is governed by 35 U.S.C. 122 and 37 CFR 1.14. This collection is estimated to take 2 hours to complete, including gathering, preparing, and submitting the completed application form to the USPTO. Time will vary depending upon the individual case. Any comments on the amount of time you require to complete this form and/or suggestions for reducing this burden, should be sent to the Chief Information Officer, U.S. Patent and Trademark Office, U.S. Department of Commerce, P.O. Box 1450, Alexandria, VA 22313-1450. DO NOT SEND FEES OR COMPLETED FORMS TO THIS ADDRESS. SEND TO: Commissioner for Patents, P.O. Box 1450, Alexandria, VA 22313-1450.

If you need assistance in completing the form, call 1-800-PTO-9199 (1-800-786-9199) and select option 2.

ALL REFERENCES CONSIDERED EXCEPT WHERE LINED THROUGH. /A.P/



UNITED STATES PATENT AND TRADEMARK OFFICE

UNITED STATES DEPARTMENT OF COMMERCE  
United States Patent and Trademark Office  
Address: COMMISSIONER FOR PATENTS  
P.O. Box 1450  
Alexandria, Virginia 22313-1450  
www.uspto.gov

| APPLICATION NUMBER | FILING OR 371(C) DATE | FIRST NAMED APPLICANT      | ATTY.DOCKET NO./TITLE | REQUEST ID |
|--------------------|-----------------------|----------------------------|-----------------------|------------|
| 16/788,498         | 02/12/2020            | Traxcell Technologies, LLC | TX1000-C12            | 116137     |

**Acknowledgement of Loss of Entitlement to Entity Status Discount**

The entity status change request below filed through Private PAIR on 07/07/2020 has been accepted.

**CERTIFICATIONS:**

**Change of Entity Status:**

Applicant changing to regular undiscounted fee status.

NOTE: Checking this box will be taken to be notification of loss of entitlement to small or micro entity status, as applicable.

This portion must be completed by the signatory or signatories making the entity status change in accordance with 37 CFR 1.4(d)(4).

|                             |                                  |
|-----------------------------|----------------------------------|
| <b>Signature:</b>           | /Andrew Mitchell Harris #42,638/ |
| <b>Name:</b>                | Andrew Mitchell Harris           |
| <b>Registration Number:</b> | 42638                            |

**PART B - FEE(S) TRANSMITTAL**

Complete and send this form, together with applicable fee(s), by mail or fax, or via EFS-Web.

By mail, send to: Mail Stop ISSUE FEE  
Commissioner for Patents  
P.O. Box 1450  
Alexandria, Virginia 22313-1450

By fax, send to: (571)-273-2885

INSTRUCTIONS: This form should be used for transmitting the ISSUE FEE and PUBLICATION FEE (if required). Blocks 1 through 5 should be completed where appropriate. All further correspondence including the Patent, advance orders and notification of maintenance fees will be mailed to the current correspondence address as indicated unless corrected below or directed otherwise in Block 1, by (a) specifying a new correspondence address; and/or (b) indicating a separate "FEE ADDRESS" for maintenance fee notifications.

CURRENT CORRESPONDENCE ADDRESS (Note: Use Block 1 for any change of address)

59911 7590 05/26/2020  
MITCH HARRIS, LLC - GENERAL  
P.O. BOX 1269  
ATHENS, GA 30603-1269

Note: A certificate of mailing can only be used for domestic mailings of the Fee(s) Transmittal. This certificate cannot be used for any other accompanying papers. Each additional paper, such as an assignment or formal drawing, must have its own certificate of mailing or transmission.

**Certificate of Mailing or Transmission**

I hereby certify that this Fee(s) Transmittal is being deposited with the United States Postal Service with sufficient postage for first class mail in an envelope addressed to the Mail Stop ISSUE FEE address above, or being transmitted to the USPTO via EFS-Web or by facsimile to (571) 273-2885, on the date below.

|                         |
|-------------------------|
| (Typed or printed name) |
| (Signature)             |
| (Date)                  |

| APPLICATION NO. | FILING DATE | FIRST NAMED INVENTOR | ATTORNEY DOCKET NO. | CONFIRMATION NO. |
|-----------------|-------------|----------------------|---------------------|------------------|
| 16/788,498      | 02/12/2020  | Mark Jefferson Reed  | TX1000-C12          | 8054             |

TITLE OF INVENTION: MOBILE WIRELESS DEVICE PROVIDING OFF-LINE AND ON-LINE GEOGRAPHIC NAVIGATION INFORMATION

| APPLN. TYPE    | ENTITY STATUS | ISSUE FEE DUE | PUBLICATION FEE DUE | PREV. PAID ISSUE FEE | TOTAL FEE(S) DUE | DATE DUE   |
|----------------|---------------|---------------|---------------------|----------------------|------------------|------------|
| nonprovisional | SMALL         | \$500         | \$0.00              | \$0.00               | \$500            | 08/26/2020 |

| EXAMINER    | ART UNIT | CLASS-SUBCLASS |
|-------------|----------|----------------|
| PATEL, AJIT | 2416     | 455-456300     |

1. Change of correspondence address or indication of "Fee Address" (37 CFR 1.363).

- Change of correspondence address (or Change of Correspondence Address form PTO/SB/122) attached.
- "Fee Address" indication (or "Fee Address" Indication form PTO/SB/47; Rev 03-09 or more recent) attached. **Use of a Customer Number is required.**

2. For printing on the patent front page, list

- (1) The names of up to 3 registered patent attorneys or agents OR, alternatively,
- (2) The name of a single firm (having as a member a registered attorney or agent) and the names of up to 2 registered patent attorneys or agents. If no name is listed, no name will be printed.

- 1 Mitch Harris, Atty at Law, LLC
- 2 Andrew M. Harris
- 3 \_\_\_\_\_

3. ASSIGNEE NAME AND RESIDENCE DATA TO BE PRINTED ON THE PATENT (print or type)

PLEASE NOTE: Unless an assignee is identified below, no assignee data will appear on the patent. If an assignee is identified below, the document must have been previously recorded, or filed for recordation, as set forth in 37 CFR 3.11 and 37 CFR 3.81(a). Completion of this form is NOT a substitute for filing an assignment.

(A) NAME OF ASSIGNEE

(B) RESIDENCE: (CITY and STATE OR COUNTRY)

TRAXCELL TECHNOLOGIES, LLC

PLANO TX

Please check the appropriate assignee category or categories (will not be printed on the patent):  Individual  Corporation or other private group entity  Government

4a. Fees submitted:  Issue Fee  Publication Fee (if required)  Advance Order - # of Copies \_\_\_\_\_

4b. Method of Payment: (Please first reapply any previously paid fee shown above)

Electronic Payment via EFS-Web  Enclosed check  Non-electronic payment by credit card (Attach form PTO-2038)

The Director is hereby authorized to charge the required fee(s), any deficiency, or credit any overpayment to Deposit Account No. \_\_\_\_\_

5. Change in Entity Status (from status indicated above)

- Applicant certifying micro entity status. See 37 CFR 1.29
- Applicant asserting small entity status. See 37 CFR 1.27
- Applicant changing to regular undiscounted fee status.

NOTE: Absent a valid certification of Micro Entity Status (see forms PTO/SB/15A and 15B), issue fee payment in the micro entity amount will not be accepted at the risk of application abandonment.

NOTE: If the application was previously under micro entity status, checking this box will be taken to be a notification of loss of entitlement to micro entity status.

NOTE: Checking this box will be taken to be a notification of loss of entitlement to small or micro entity status, as applicable.

NOTE: This form must be signed in accordance with 37 CFR 1.31 and 1.33. See 37 CFR 1.4 for signature requirements and certifications.

Authorized Signature /Andrew Mitchell Harris #42,638/ Date 07-13-2020

Typed or printed name Andrew Mitchell Harris Registration No. 42,638

## Electronic Patent Application Fee Transmittal

|  |   |                 |               |                             |
|--|---|-----------------|---------------|-----------------------------|
| <b>Application Number:</b>                         | 16788498  |                 |               |                             |
| <b>Filing Date:</b>                                | 12-Feb-2020   |                 |               |                             |
| <b>Title of Invention:</b>                         | MOBILE WIRELESS DEVICE PROVIDING OFF-LINE AND ON-LINE GEOGRAPHIC NAVIGATION INFORMATION |                 |               |                             |
| <b>First Named Inventor/Applicant Name:</b>        | Mark Jefferson Reed   |                 |               |                             |
| <b>Filer:</b>                                      | Andrew Mitchell Harris  |                 |               |                             |
| <b>Attorney Docket Number:</b>                     | TX1000-C12  |                 |               |                             |
| Filed as Large Entity                              |   |                 |               |                             |
| <b>Filing Fees for Utility under 35 USC 111(a)</b> |   |                 |               |                             |
| <b>Description</b>                                 | <b>Fee Code</b>   | <b>Quantity</b> | <b>Amount</b> | <b>Sub-Total in USD(\$)</b> |
| <b>Basic Filing:</b>                               |   |                 |               |                             |
| <b>Pages:</b>                                      |   |                 |               |                             |
| <b>Claims:</b>                                     |   |                 |               |                             |
| <b>Miscellaneous-Filing:</b>                       |   |                 |               |                             |
| <b>Petition:</b>                                   |   |                 |               |                             |
| <b>Patent-Appeals-and-Interference:</b>            |   |                 |               |                             |
| <b>Post-Allowance-and-Post-Issuance:</b>           |   |                 |               |                             |
| UTILITY APPL ISSUE FEE                             | 1501  | 1               | 1000          | 1000                        |

| Description               | Fee Code | Quantity | Amount | Sub-Total in USD(\$) |
|---------------------------|----------|----------|--------|----------------------|
| <b>Extension-of-Time:</b> |          |          |        |                      |
| <b>Miscellaneous:</b>     |          |          |        |                      |
| <b>Total in USD (\$)</b>  |          |          |        | <b>1000</b>          |



## Electronic Acknowledgement Receipt

|   |   |
|---|---|
| <b>EFS ID:</b>                              | 39978940  |
| <b>Application Number:</b>                  | 16788498  |
| <b>International Application Number:</b>    |   |
| <b>Confirmation Number:</b>                 | 8054  |
| <b>Title of Invention:</b>                  | MOBILE WIRELESS DEVICE PROVIDING OFF-LINE AND ON-LINE GEOGRAPHIC NAVIGATION INFORMATION |
| <b>First Named Inventor/Applicant Name:</b> | Mark Jefferson Reed   |
| <b>Customer Number:</b>                     | 59911   |
| <b>Filer:</b>                               | Andrew Mitchell Harris  |
| <b>Filer Authorized By:</b>                 |   |
| <b>Attorney Docket Number:</b>              | TX1000-C12  |
| <b>Receipt Date:</b>                        | 13-JUL-2020   |
| <b>Filing Date:</b>                         | 12-FEB-2020   |
| <b>Time Stamp:</b>                          | 12:25:12  |
| <b>Application Type:</b>                    | Utility under 35 USC 111(a)   |

### Payment information:

|  |                  |
|--|------------------|
| Submitted with Payment                   | yes              |
| Payment Type                             | CARD             |
| Payment was successfully received in RAM | \$ 1000          |
| RAM confirmation Number                  | E20207CC28115925 |
| Deposit Account                          |                  |
| Authorized User                          |                  |

The Director of the USPTO is hereby authorized to charge indicated fees and credit any overpayment as follows:

| <b>File Listing:</b>  |                             |                                     |  |                         |                         |
|---|-----------------------------|-------------------------------------|--|-------------------------|-------------------------|
| <b>Document Number</b>  | <b>Document Description</b> | <b>File Name</b>                    | <b>File Size(Bytes)/<br/>Message Digest</b>            | <b>Multi Part /.zip</b> | <b>Pages (if appl.)</b> |
| 1   | Issue Fee Payment (PTO-85B) | TX1000-<br>C12_ptol85b_07-13-20.pdf | 117014<br><br>b812d5954d5f711624787e263f63850fed2c6039 | no                      | 1                       |
| <b>Warnings:</b>  |                             |                                     |  |                         |                         |
| <b>Information:</b>   |                             |                                     |  |                         |                         |
| 2   | Fee Worksheet (SB06)        | fee-info.pdf                        | 30699<br><br>e5749144b745913550e591aa508ca1d86d5621af  | no                      | 2                       |
| <b>Warnings:</b>  |                             |                                     |  |                         |                         |
| <b>Information:</b>   |                             |                                     |  |                         |                         |
| <b>Total Files Size (in bytes):</b>   |                             |                                     | 147713   |                         |                         |
| <p><b>This Acknowledgement Receipt evidences receipt on the noted date by the USPTO of the indicated documents, characterized by the applicant, and including page counts, where applicable. It serves as evidence of receipt similar to a Post Card, as described in MPEP 503.</b></p> <p><b><u>New Applications Under 35 U.S.C. 111</u></b><br/> <b>If a new application is being filed and the application includes the necessary components for a filing date (see 37 CFR 1.53(b)-(d) and MPEP 506), a Filing Receipt (37 CFR 1.54) will be issued in due course and the date shown on this Acknowledgement Receipt will establish the filing date of the application.</b></p> <p><b><u>National Stage of an International Application under 35 U.S.C. 371</u></b><br/> <b>If a timely submission to enter the national stage of an international application is compliant with the conditions of 35 U.S.C. 371 and other applicable requirements a Form PCT/DO/EO/903 indicating acceptance of the application as a national stage submission under 35 U.S.C. 371 will be issued in addition to the Filing Receipt, in due course.</b></p> <p><b><u>New International Application Filed with the USPTO as a Receiving Office</u></b><br/> <b>If a new international application is being filed and the international application includes the necessary components for an international filing date (see PCT Article 11 and MPEP 1810), a Notification of the International Application Number and of the International Filing Date (Form PCT/RO/105) will be issued in due course, subject to prescriptions concerning national security, and the date shown on this Acknowledgement Receipt will establish the international filing date of the application.</b></p> |                             |                                     |  |                         |                         |



UNITED STATES PATENT AND TRADEMARK OFFICE

UNITED STATES DEPARTMENT OF COMMERCE
United States Patent and Trademark Office
Address: COMMISSIONER FOR PATENTS
P.O. Box 1450
Alexandria, Virginia 22313-1450
www.uspto.gov

Table with 4 columns: APPLICATION NUMBER (16/788,498), FILING OR 371(C) DATE (02/12/2020), FIRST NAMED APPLICANT (Mark Jefferson Reed), ATTY. DOCKET NO./TITLE (TX1000-C12)

CONFIRMATION NO. 8054

PUBLICATION NOTICE

59911
MITCH HARRIS, LLC - GENERAL
P.O. BOX 1269
ATHENS, GA 30603-1269



Title:MOBILE WIRELESS DEVICE PROVIDING OFF-LINE AND ON-LINE GEOGRAPHIC NAVIGATION INFORMATION

Publication No.US-2020-0236496-A1

Publication Date:07/23/2020

NOTICE OF PUBLICATION OF APPLICATION

The above-identified application will be electronically published as a patent application publication pursuant to 37 CFR 1.211, et seq. The patent application publication number and publication date are set forth above.

The publication may be accessed through the USPTO's publicly available Searchable Databases via the Internet at www.uspto.gov. The direct link to access the publication is currently http://www.uspto.gov/patft/.

The publication process established by the Office does not provide for mailing a copy of the publication to applicant. A copy of the publication may be obtained from the Office upon payment of the appropriate fee set forth in 37 CFR 1.19(a)(1). Orders for copies of patent application publications are handled by the USPTO's Public Records Division. The Public Records Division can be reached by telephone at (571) 272-3150 or (800) 972-6382, by facsimile at (571) 273-3250, by mail addressed to the United States Patent and Trademark Office, Public Records Division, Alexandria, VA 22313-1450 or via the Internet.

In addition, information on the status of the application, including the mailing date of Office actions and the dates of receipt of correspondence filed in the Office, may also be accessed via the Internet through the Patent Electronic Business Center at www.uspto.gov using the public side of the Patent Application Information and Retrieval (PAIR) system. The direct link to access this status information is currently https://portal.uspto.gov/pair/PublicPair. Prior to publication, such status information is confidential and may only be obtained by applicant using the private side of PAIR.

Further assistance in electronically accessing the publication, or about PAIR, is available by calling the Patent Electronic Business Center at 1-866-217-9197.

Office of Data Management, Application Assistance Unit (571) 272-4000, or (571) 272-4200, or 1-888-786-0101



# United States Patent and Trademark Office

*Office of the Chief Financial Officer*

Document Code:WFEE

User :C41722

Sale Accounting Date:08/31/2020

---

| Sale Item Reference Number | Effective Date |
|----------------------------|----------------|
| 16788498                   | 06/15/2020     |

| Document Number  | Fee Code | Fee Code Description                     | Amount Paid | Payment Method |
|------------------|----------|--|-------------|----------------|
| I20208U907415612 | 1461     | 1.28(C) SUBMISSIONS - APPLIC<br>FILE FEE | \$4,185.00  | Salea          |



UNITED STATES PATENT AND TRADEMARK OFFICE

UNITED STATES DEPARTMENT OF COMMERCE
United States Patent and Trademark Office
Address: COMMISSIONER FOR PATENTS
P.O. Box 1450
Alexandria, Virginia 22313-1450
www.uspto.gov

Table with columns: APPLICATION NO., FILING DATE, FIRST NAMED INVENTOR, ATTORNEY DOCKET NO., CONFIRMATION NO., EXAMINER, ART UNIT, PAPER NUMBER, MAIL DATE, DELIVERY MODE. Includes application details for Mark Jefferson Reed and Mitch Harris, LLC.

Please find below and/or attached an Office communication concerning this application or proceeding.

The time period for reply, if any, is set in the attached communication.



UNITED STATES PATENT AND TRADEMARK OFFICE

Commissioner for Patents  
United States Patent and Trademark Office  
P.O. Box 1450  
Alexandria, VA 22313-1450  
www.uspto.gov

In re Application of :  
Reed et al. :  
Application No. 16/788,498 :  
Filed: February 12, 2020 : DECISION ON PETITION  
For: MOBILE WIRELESS DEVICE :  
PROVIDING OFF-LINE AND ON-LINE :  
GEOGRAPHIC NAVIGATION :  
INFORMATION :

This is a Notice regarding the request for acceptance of a fee deficiency submission under 37 CFR 1.28(c) filed June 15, 2020.

The Office no longer investigates or rejects original or reissue applications under 37 CFR 1.56. 1098 Off. Gaz. Pat. Office 502 (January 3, 1989). Therefore, nothing in this Notice is intended to imply that an investigation was done.

The fee deficiency submission under 37 CFR 1.28(c) is **ACCEPTED**. Accordingly, status as a small entity has been removed and any future fee(s) submitted must be paid at the undiscounted rate.

Inquiries related to this communication should be directed to LaShawn Marks at (571) 272-7141.

/JOANNE L BURKE/  
Lead Paralegal Specialist, OPET



UNITED STATES PATENT AND TRADEMARK OFFICE

UNITED STATES DEPARTMENT OF COMMERCE
United States Patent and Trademark Office
Address: COMMISSIONER FOR PATENTS
P.O. Box 1450
Alexandria, Virginia 22313-1450
www.uspto.gov

Table with 5 columns: APPLICATION NO., FILING DATE, FIRST NAMED INVENTOR, ATTORNEY DOCKET NO., CONFIRMATION NO.
Row 1: 16/788,498, 02/12/2020, Mark Jefferson Reed, TX1000-C12, 8054
Row 2: 59911, 7590, 09/28/2020, MITCH HARRIS, LLC - GENERAL, P.O. BOX 1269, ATHENS, GA 30603-1269
Row 3: EXAMINER, PATEL, AJIT
Row 4: ART UNIT, PAPER NUMBER, 2416
Row 5: MAIL DATE, DELIVERY MODE, 09/28/2020, PAPER

Please find below and/or attached an Office communication concerning this application or proceeding.

The time period for reply, if any, is set in the attached communication.

|   |                                      |                                    |                                |
|---|--------------------------------------|------------------------------------|--------------------------------|
| <b>Corrected<br/>Notice of Allowability</b> | <b>Application No.</b><br>16/788,498 | <b>Applicant(s)</b><br>Reed et al. |                                |
|   | <b>Examiner</b><br>AJIT PATEL        | <b>Art Unit</b><br>2416            | <b>AIA (FITF) Status</b><br>No |

**-- The MAILING DATE of this communication appears on the cover sheet with the correspondence address--**

All claims being allowable, PROSECUTION ON THE MERITS IS (OR REMAINS) CLOSED in this application. If not included herewith (or previously mailed), a Notice of Allowance (PTOL-85) or other appropriate communication will be mailed in due course. **THIS NOTICE OF ALLOWABILITY IS NOT A GRANT OF PATENT RIGHTS.** This application is subject to withdrawal from issue at the initiative of the Office or upon petition by the applicant. See 37 CFR 1.313 and MPEP 1308.

1.  This communication is responsive to 7/2/20.  
 A declaration(s)/affidavit(s) under **37 CFR 1.130(b)** was/were filed on \_\_\_\_.
2.  An election was made by the applicant in response to a restriction requirement set forth during the interview on \_\_\_\_; the restriction requirement and election have been incorporated into this action.
3.  The allowed claim(s) is/are See Continuation Sheet. As a result of the allowed claim(s), you may be eligible to benefit from the **Patent Prosecution Highway** program at a participating intellectual property office for the corresponding application. For more information, please see [http://www.uspto.gov/patents/init\\_events/pph/index.jsp](http://www.uspto.gov/patents/init_events/pph/index.jsp) or send an inquiry to [PPHfeedback@uspto.gov](mailto:PPHfeedback@uspto.gov).
4.  Acknowledgment is made of a claim for foreign priority under 35 U.S.C. § 119(a)-(d) or (f).  
**Certified copies:**  
a)  All    b)  Some    \*c)  None of the:  
1.  Certified copies of the priority documents have been received.  
2.  Certified copies of the priority documents have been received in Application No. \_\_\_\_.  
3.  Copies of the certified copies of the priority documents have been received in this national stage application from the International Bureau (PCT Rule 17.2(a)).  
\* Certified copies not received: \_\_\_\_.

Applicant has THREE MONTHS FROM THE "MAILING DATE" of this communication to file a reply complying with the requirements noted below. Failure to timely comply will result in ABANDONMENT of this application.

**THIS THREE-MONTH PERIOD IS NOT EXTENDABLE.**

5.  CORRECTED DRAWINGS (as "replacement sheets") must be submitted.  
 including changes required by the attached Examiner's Amendment / Comment or in the Office action of Paper No./Mail Date \_\_\_\_.  
**Identifying indicia such as the application number (see 37 CFR 1.84(c)) should be written on the drawings in the front (not the back) of each sheet. Replacement sheet(s) should be labeled as such in the header according to 37 CFR 1.121(d).**
6.  DEPOSIT OF and/or INFORMATION about the deposit of BIOLOGICAL MATERIAL must be submitted. Note the attached Examiner's comment regarding REQUIREMENT FOR THE DEPOSIT OF BIOLOGICAL MATERIAL.

**Attachment(s)**

- |   |   |
|---|---|
| 1. <input type="checkbox"/> Notice of References Cited (PTO-892)<br>2. <input type="checkbox"/> Information Disclosure Statements (PTO/SB/08),<br>Paper No./Mail Date ____.<br>3. <input type="checkbox"/> Examiner's Comment Regarding Requirement for Deposit<br>of Biological Material ____.<br>4. <input checked="" type="checkbox"/> Interview Summary (PTO-413),<br>Paper No./Mail Date ____. | 5. <input checked="" type="checkbox"/> Examiner's Amendment/Comment<br>6. <input type="checkbox"/> Examiner's Statement of Reasons for Allowance<br>7. <input type="checkbox"/> Other ____. |
|---|---|

|   |  |
|---|--|
| /AJIT PATEL/<br>Primary Examiner, Art Unit 2416 |  |
|---|--|



Continuation of 3. The allowed claim(s) is/are: 1,3-6,9-18,20-21,23-27 and 29-30

**DETAILED ACTION**

***Notice of Pre-AIA or AIA Status***

1. The present application is being examined under the pre-AIA first to invent provisions.

**EXAMINER'S AMENDMENT**

2. An examiner's amendment to the record appears below. Should the changes and/or additions be unacceptable to applicant, an amendment may be filed as provided by 37 CFR 1.312. To ensure consideration of such an amendment, it **MUST** be submitted no later than the payment of the issue fee.

Authorization for this examiner's amendment was given in an interview with Mr. Harris on 9/25/20.

3. The application has been amended as follows:

In claim 6 (original), line 1, "2" has been changed to --1--.

In claim 20 (original), line 1, "19" has been changed to --14 --.

***Conclusion***

4. Any inquiry concerning this communication or earlier communications from the examiner should be directed to AJIT PATEL whose telephone number is (571)272-3140. The examiner can normally be reached on Monday-Friday 9AM-5PM.

Examiner interviews are available via telephone, in-person, and video conferencing using a USPTO supplied web-based collaboration tool. To schedule an

interview, applicant is encouraged to use the USPTO Automated Interview Request (AIR) at <http://www.uspto.gov/interviewpractice>.

If attempts to reach the examiner by telephone are unsuccessful, the examiner's supervisor, NOEL BEHARRY can be reached on 571-270-5630. The fax phone number for the organization where this application or proceeding is assigned is 571-273-8300.

Information regarding the status of an application may be obtained from the Patent Application Information Retrieval (PAIR) system. Status information for published applications may be obtained from either Private PAIR or Public PAIR. Status information for unpublished applications is available through Private PAIR only. For more information about the PAIR system, see <https://ppair-my.uspto.gov/pair/PrivatePair>. Should you have questions on access to the Private PAIR system, contact the Electronic Business Center (EBC) at 866-217-9197 (toll-free). If you would like assistance from a USPTO Customer Service Representative or access to the automated information system, call 800-786-9199 (IN USA OR CANADA) or 571-272-1000.

/AJIT PATEL/  
Primary Examiner, Art Unit 2416

|  |                                      |                                    |  |                       |
|--|--------------------------------------|------------------------------------|--|-----------------------|
| <b><i>Examiner-Initiated Interview Summary</i></b> | <b>Application No.</b><br>16/788,498 | <b>Applicant(s)</b><br>Reed et al. |  |                       |
|  | <b>Examiner</b><br>AJIT PATEL        | <b>Art Unit</b><br>2416            | <b>AIA (First Inventor to File) Status</b><br>No | <b>Page</b><br>1 of 1 |

| All Participants (applicant, applicants representative, PTO personnel) | Title            | Type       |
|--|------------------|------------|
| AJIT PATEL   | Primary Examiner | Telephonic |
| Mr. Harris   |                  |            |

**Date of Interview:** 25 September 2020

**Issues Discussed:**

**Other**

The examiner and the attorney discussed the dependency of original claims 6 and 20. The attorney authorized the examiner's amendment.

|  |  |
|--|--|
| /AJIT PATEL/<br>Primary Examiner, Art Unit 2416  |  |
| <p><b>Applicant is reminded that a complete written statement as to the substance of the interview must be made of record in the application file. It is the applicants responsibility to provide the written statement, unless the interview was initiated by the Examiner and the Examiner has indicated that a written summary will be provided. See MPEP 713.04</b></p> <p>Please further see:<br/>         MPEP 713.04<br/>         Title 37 Code of Federal Regulations (CFR) § 1.133 Interviews, paragraph (b)<br/>         37 CFR § 1.2 Business to be transacted in writing</p> |  |

**Applicant recordation instructions:** It is not necessary for applicant to provide a separate record of the substance of interview.

**Examiner recordation instructions:** Examiners must summarize the substance of any interview of record. A complete and proper recordation of the substance of an interview should include the items listed in MPEP 713.04 for complete and proper recordation including the identification of the general thrust of each argument or issue discussed, a general indication of any other pertinent matters discussed regarding patentability and the general results or outcome of the interview, to include an indication as to whether or not agreement was reached on the issues raised.



UNITED STATES PATENT AND TRADEMARK OFFICE

UNITED STATES DEPARTMENT OF COMMERCE
United States Patent and Trademark Office
Address: COMMISSIONER FOR PATENTS
P.O. Box 1450
Alexandria, Virginia 22313-1450
www.uspto.gov

Table with 5 columns: APPLICATION NO., ISSUE DATE, PATENT NO., ATTORNEY DOCKET NO., CONFIRMATION NO.
Row 1: 16/788,498, 10/27/2020, 10820147, TX1000-C12, 8054

59911 7590 10/07/2020
MITCH HARRIS, LLC - GENERAL
P.O. BOX 1269
ATHENS, GA 30603-1269

ISSUE NOTIFICATION

The projected patent number and issue date are specified above.

Determination of Patent Term Adjustment under 35 U.S.C. 154 (b)
(application filed on or after May 29, 2000)

The Patent Term Adjustment is 0 day(s). Any patent to issue from the above-identified application will include an indication of the adjustment on the front page.

If a Continued Prosecution Application (CPA) was filed in the above-identified application, the filing date that determines Patent Term Adjustment is the filing date of the most recent CPA.

Applicant will be able to obtain more detailed information by accessing the Patent Application Information Retrieval (PAIR) WEB site (http://pair.uspto.gov).

Any questions regarding the Patent Term Extension or Adjustment determination should be directed to the Office of Patent Legal Administration at (571)-272-7702. Questions relating to issue and publication fee payments should be directed to the Application Assistance Unit (AAU) of the Office of Data Management (ODM) at (571)-272-4200.

APPLICANT(s) (Please see PAIR WEB site http://pair.uspto.gov for additional applicants):

Mark Jefferson Reed, Tucson, AZ;
Traxcell Technologies, LLC, Plano, TX;
Stephen Michael Palik, Redondo Beach, CA;

The United States represents the largest, most dynamic marketplace in the world and is an unparalleled location for business investment, innovation, and commercialization of new technologies. The USA offers tremendous resources and advantages for those who invest and manufacture goods here. Through SelectUSA, our nation works to encourage and facilitate business investment. To learn more about why the USA is the best country in the world to develop technology, manufacture products, and grow your business, visit SelectUSA.gov.

IR 103 (Rev. 10/09)