

- [54] **FE BASED SOFT MAGNETIC ALLOY, MAGNETIC MATERIALS CONTAINING SAME, AND MAGNETIC APPARATUS USING THE MAGNETIC MATERIALS**
- [75] Inventors: **Kiyonori Suzuki**, Sendai; **Akihiro Makino**, Nagaoka; **Tsuyoshi Masumoto**, 8-22 3 chome, Uesugi, Aoba-ku, Sendai-shi, Miyagi-ken; **Akihisa Inoue**; **Noriyuki Kataoka**, both of Sendai, all of Japan
- [73] Assignees: **Alps Electric Co., Ltd.**, Tokyo; **Tsuyoshi Masumoto**, Sendai, both of Japan
- [21] Appl. No.: **201,135**
- [22] Filed: **Feb. 24, 1994**

4,918,555	4/1990	Yoshizawa et al.	360/125
4,985,089	1/1991	Yoshizawa et al.	148/311
5,028,280	7/1991	Ihara et al.	148/310
5,069,731	12/1991	Yoshizawa et al.	148/306
5,144,999	9/1992	Makino et al.	164/423
5,148,855	9/1992	Ashok	164/479

FOREIGN PATENT DOCUMENTS

242063	9/1960	Australia	.
0271657	6/1988	European Pat. Off.	148/305
WO84/03852	10/1984	WIPO	.
WO87/00462	1/1987	WIPO	.

Primary Examiner—John Sheehan
Attorney, Agent, or Firm—Guy W. Shoup; Patrick T. Bever

[57] **ABSTRACT**

An Fe-based soft magnetic alloy having a high saturated magnetic flux density and having a composition represented by formula (I) below:



wherein Q represents at least one element selected from the group consisting of Co and Ni; T represents at least one element selected from the group consisting of Ti, Zr, Hf, V, Nb, Ta, Mo and W, with Zr and/or Hf being always included; T' represents at least one element selected from the group consisting of Cu, Ag, Au, Ni, Pd and Pt; a, b, x, y and z are real numbers satisfying relationships below:
 $0 \leq a \leq 0.05$ atomic %,
 $0 < b \leq 93$ atomic %,
 $0.5 \leq x \leq 16$ atomic %,
 $4 \leq y \leq 10$ atomic %,
 $0 \leq z \leq 4.5$ atomic %

provided that when $0 < z \leq 4.5$ atomic %, Q represents Co and $0 < b \leq 92$ atomic %; and when $z=0$, $0.5 \leq x \leq 8$ atomic % and $4 \leq y \leq 9$ atomic %. Also disclosed are soft magnetic materials such as thin films, ribbons, and powder magnetic transducers such as low frequency transformers and magnetic heads using the material. Finally, processes and apparatuses for producing ribbons formed from the alloy are disclosed.

4 Claims, 19 Drawing Sheets

Related U.S. Application Data

- [63] Continuation of Ser. No. 690,201, Apr. 23, 1991, abandoned.

[30] **Foreign Application Priority Data**

Apr. 24, 1990	[JP]	Japan	2-108308
Aug. 31, 1990	[JP]	Japan	2-230135
Sep. 7, 1990	[JP]	Japan	2-237752
Sep. 7, 1990	[JP]	Japan	2-237753
Sep. 7, 1990	[JP]	Japan	2-237754
Sep. 7, 1990	[JP]	Japan	2-237755
Sep. 7, 1990	[JP]	Japan	2-237757
Sep. 7, 1990	[JP]	Japan	2-237758
Sep. 13, 1990	[JP]	Japan	2-243589
Sep. 13, 1990	[JP]	Japan	2-243590
Nov. 27, 1990	[JP]	Japan	2-324518
Nov. 27, 1990	[JP]	Japan	2-324519

- [51] **Int. Cl.⁶** **H01F 1/147**
- [52] **U.S. Cl.** **148/306; 148/310; 148/311; 148/305; 420/121; 420/125; 75/244**
- [58] **Field of Search** **148/305, 306, 310, 311; 420/121, 125; 75/244**

References Cited

U.S. PATENT DOCUMENTS

4,257,830	3/1981	Tsuya et al.	148/112
4,718,475	2/1988	Das et al.	164/415
4,735,865	4/1988	Nago et al.	428/610
4,750,951	6/1988	Makino et al.	148/304

• Fe₈₀Cu₁₀B₅Zr₅
 ○ Fe₉₁Zr₇B₂

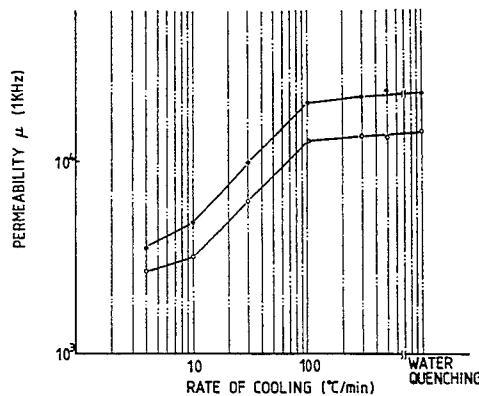

FIG. 1
PRIOR ART

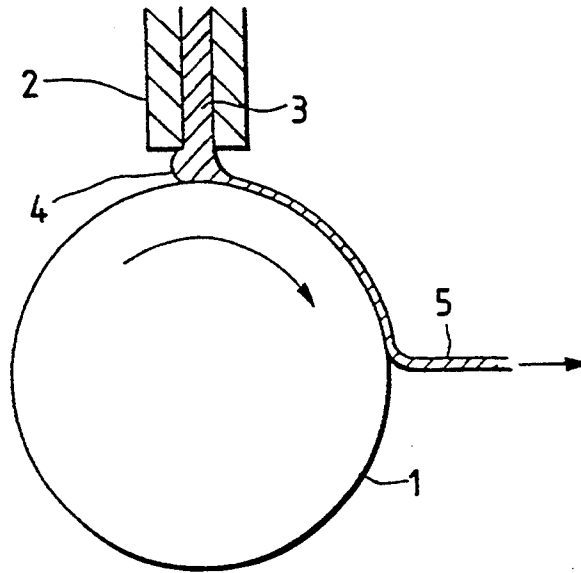

FIG. 2

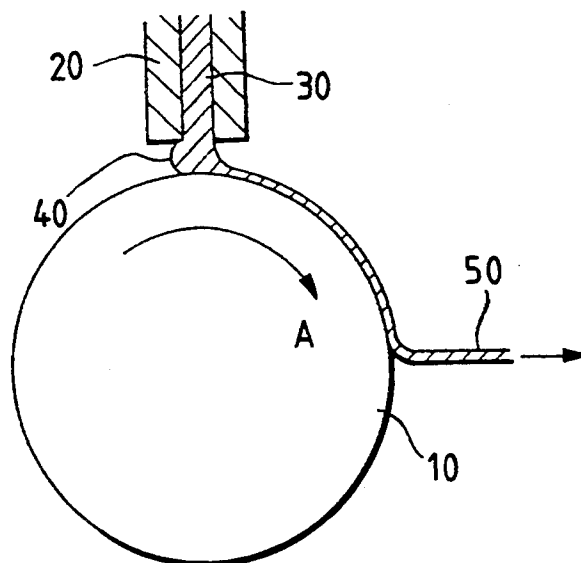

FIG. 3

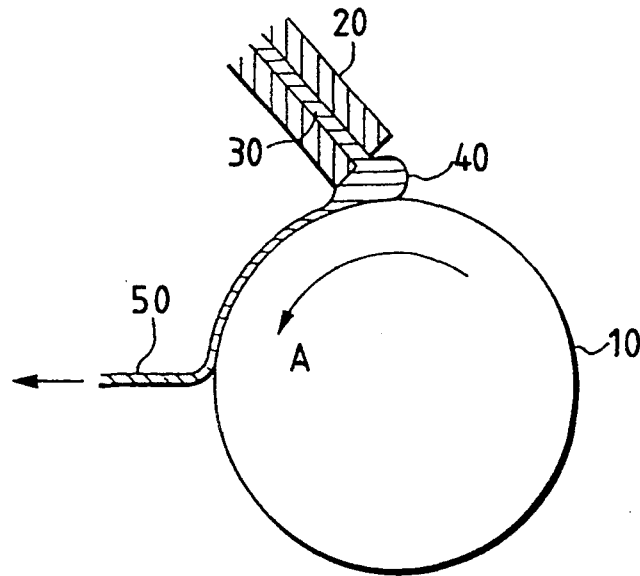

FIG. 4

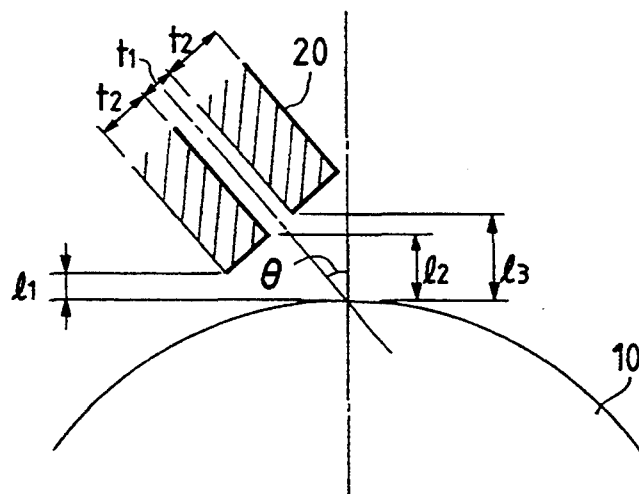

FIG. 6

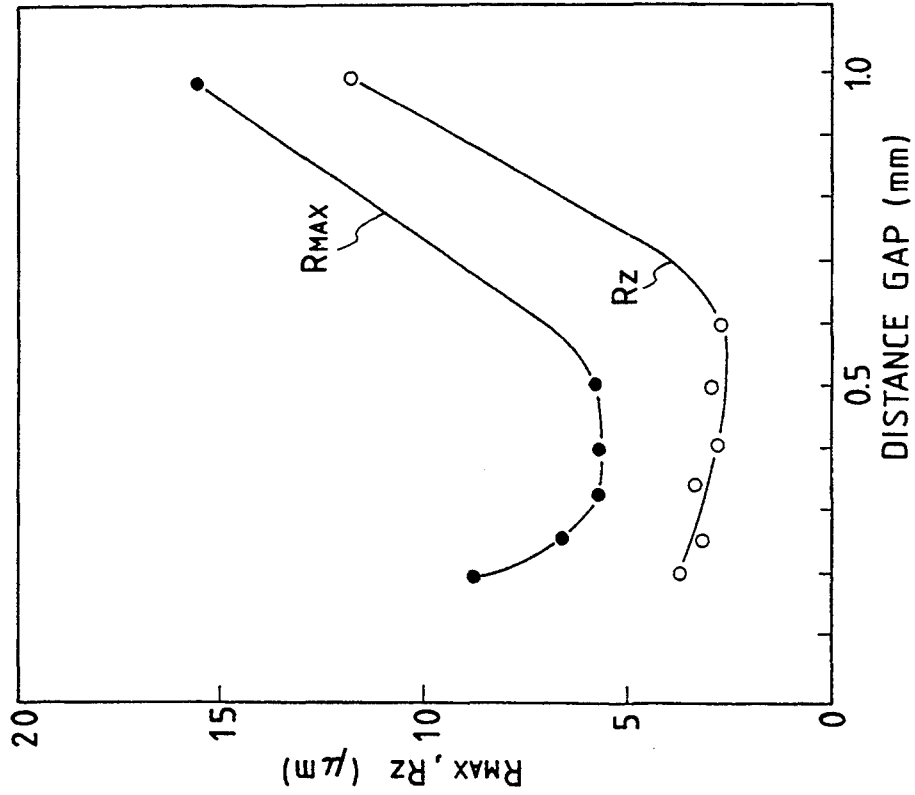

FIG. 5

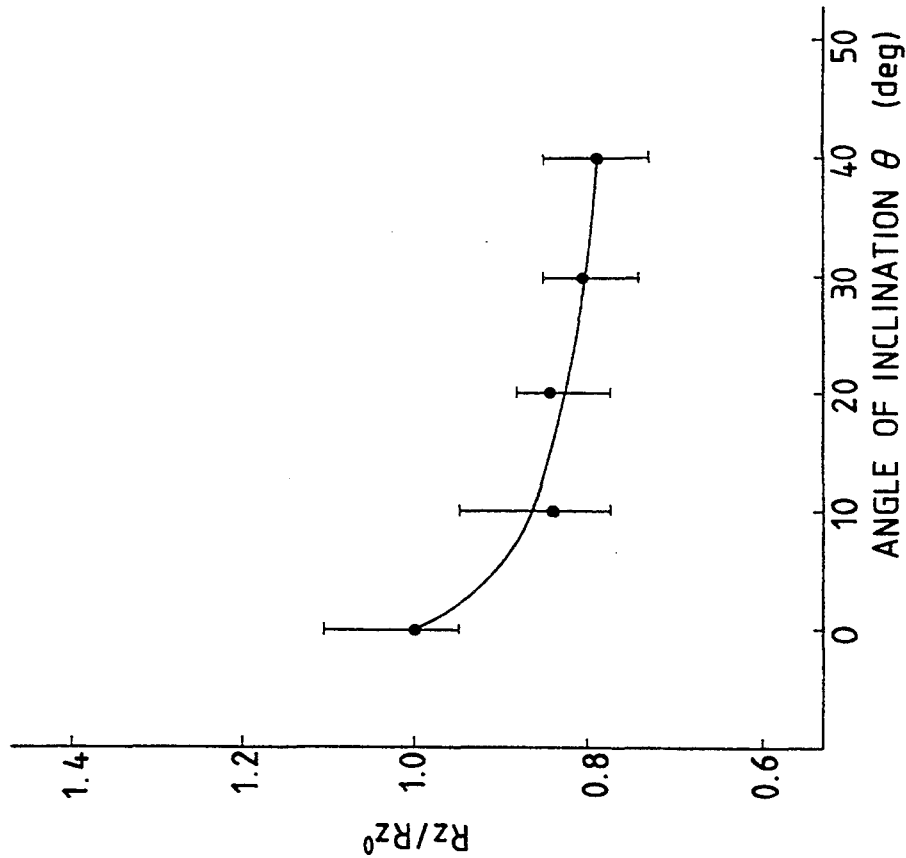
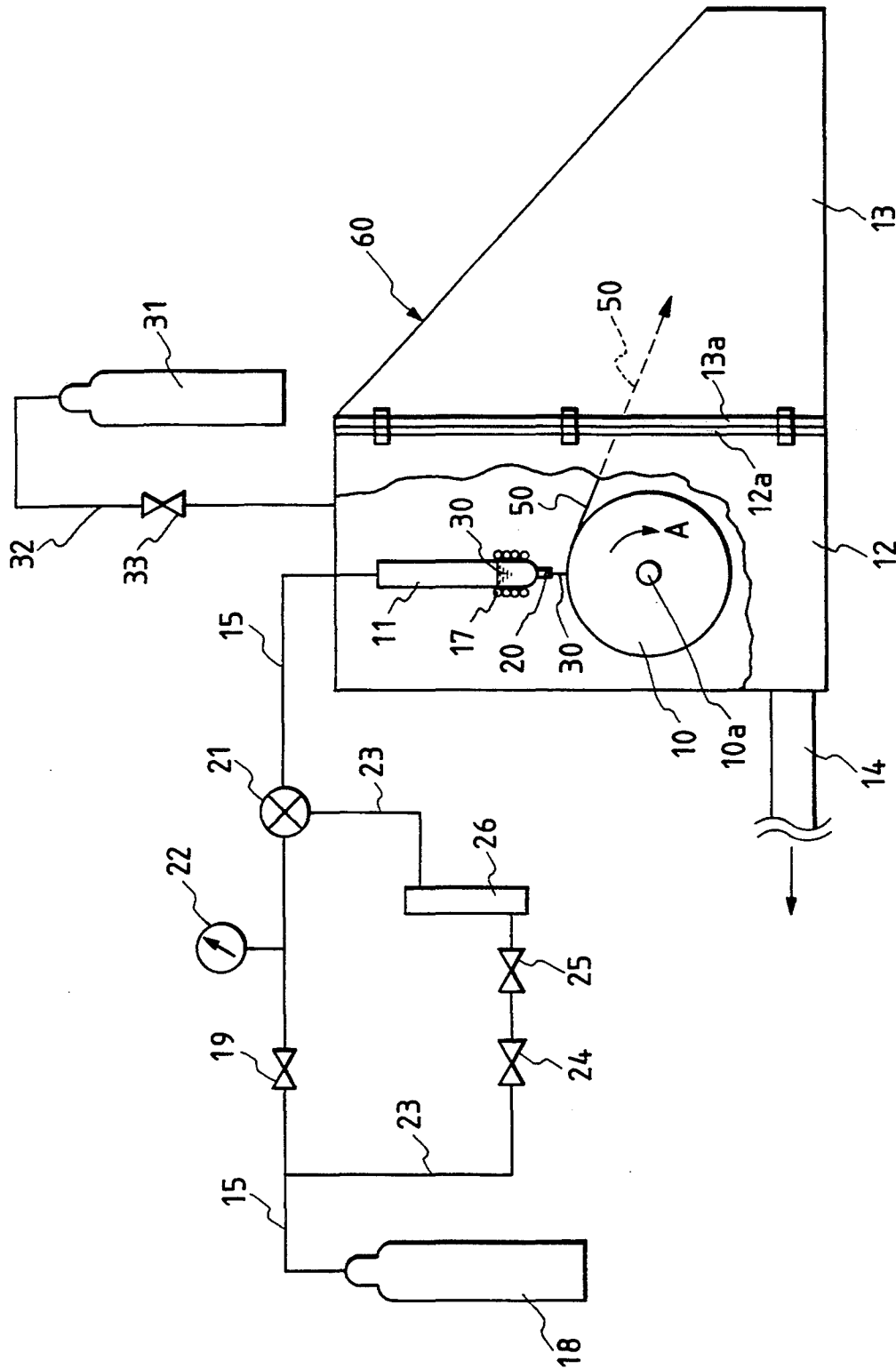

FIG. 7



Explore Litigation Insights

Docket Alarm provides insights to develop a more informed litigation strategy and the peace of mind of knowing you're on top of things.

Real-Time Litigation Alerts



Keep your litigation team up-to-date with **real-time alerts** and advanced team management tools built for the enterprise, all while greatly reducing PACER spend.

Our comprehensive service means we can handle Federal, State, and Administrative courts across the country.

Advanced Docket Research



With over 230 million records, Docket Alarm's cloud-native docket research platform finds what other services can't. Coverage includes Federal, State, plus PTAB, TTAB, ITC and NLRB decisions, all in one place.

Identify arguments that have been successful in the past with full text, pinpoint searching. Link to case law cited within any court document via Fastcase.

Analytics At Your Fingertips



Learn what happened the last time a particular judge, opposing counsel or company faced cases similar to yours.

Advanced out-of-the-box PTAB and TTAB analytics are always at your fingertips.

API

Docket Alarm offers a powerful API (application programming interface) to developers that want to integrate case filings into their apps.

LAW FIRMS

Build custom dashboards for your attorneys and clients with live data direct from the court.

Automate many repetitive legal tasks like conflict checks, document management, and marketing.

FINANCIAL INSTITUTIONS

Litigation and bankruptcy checks for companies and debtors.

E-DISCOVERY AND LEGAL VENDORS

Sync your system to PACER to automate legal marketing.