

Microprocessor Data Book

SECOND EDITION

S. A. Money



ACADEMIC PRESS, INC.

Harcourt Brace Jovanovich, Publishers

San Diego New York Boston

London Sydney Tokyo Toronto

This book is printed on acid-free paper. ∞

Copyright © 1990, 1982 by S. A. Money

All Rights Reserved.

No part of this publication may be reproduced or transmitted in any form or by any means, electronic or mechanical, including photocopy, recording, or any information storage and retrieval system, without permission in writing from the publisher.

Academic Press, Inc.
San Diego, California 92101

United Kingdom Edition published by
Blackwell Scientific Publications Limited
Osney Mead, Oxford OX2 0EL, England

Library of Congress Cataloging-in-Publication Data

Money, Steve A.

Microprocessor data book / S. A. Money. -- 2nd ed.

p. cm.

Includes bibliographical references.

ISBN 0-12-504445-3 (alk. paper)

1. Microprocessors. 2. Microcomputers. I. Title.

QA76.5.M549 1990

004.16--dc20

90-300

CIP

Printed in the United States of America

90 91 92 93 9 8 7 6 5 4 3 2 1

PREFACE

Advances in the techniques for manufacturing large scale integrated (LSI) circuits have, in recent years, made it feasible to incorporate most, or in some cases all, of the complex logic required for a small digital computer system on to a single silicon chip. One example of the application of these LSI techniques is in the familiar digital pocket calculator, which is in fact a specialised digital computer. In these devices all of the electronic logic is contained in a single integrated circuit package.

In designing modern electronic systems the engineer must now take into account the ready availability of microcomputer and microprocessor devices which can simplify design, making the end product more versatile or more economical to produce.

One problem which faces the designer planning to use a microprocessor is the great multiplicity of devices that have become available. Choosing a suitable microprocessor could involve collecting together and searching through a mountain of different data sheets and manuals.

In this book condensed data have been provided for most of the available types of microprocessor and micro-computer device. For each major type or series a description is given of the internal architecture, instruction set, main electrical data and package details.

Most of the popular devices are manufactured by several different suppliers, and a list of alternative sources and type numbers have been included in the data for each type. Support chips designed for that processor have also been listed.

For convenience the devices have been divided into groups covering 4, 8 and 16-bit types and other processors. It would not be practical to include full details of each type, but it is hoped that sufficient information has been provided to allow the designer to narrow down his choice to perhaps one or two types. The manufacturer's data sheets or manuals may then be consulted for more detailed operating and application information.

In order to choose a processor for a project some knowledge of the basic principles of the devices is re-

quired, and this has been covered in the introductory chapter. A general guide has also been included on the factors involved when a processor type is chosen.

A complete system normally consists of a microprocessor together with a selection of supporting devices to handle input-output, external device control and to provide memory. The number of support devices available is even greater than that of microprocessor types, so no attempt has been made to include details of all of these. Some descriptions have been included covering the major support device functions, and data have been included on some of the more popular types as a guide to the facilities provided by such devices.

At the end of the book a directory of microprocessor manufacturers has been included and there is also a glossary of some of the terminology used in the microprocessor field.

It is hoped that the information given in this book will assist designers in choosing suitable devices and that it will be generally useful to those engaged in designing or planning microprocessor based products.

One problem encountered in producing any data book which deals with a rapidly advancing field, such as microprocessors, is that new devices are continually being introduced. To deal with this situation plans are being made for the publication, from time to time, of a supplement giving data on recently introduced devices. Readers wishing to have details of these supplements should complete and mail the coupon enclosed in this book, or alternatively write to the publishers, when they will automatically receive advance details of these supplements.

The reader will notice that for a limited number of devices in this book only limited data are given. This is because at the time of compilation only preliminary information was available. The reader is referred to the supplement for full information.

Finally, I would like to express my thanks to all those manufacturers and distributors who supplied the data and other information which made it possible to compile this book.

1 INTRODUCTION

In recent years the advent of microprocessors and microcomputers has revolutionised the whole process of digital system design. Projects which, a few years ago, might have required tens or hundreds of digital logic devices can today be implemented by using perhaps one or two LSI circuits. Of course LSI circuits have been around for some years, but economic considerations have usually limited these to applications, such as digital calculators where high volume production is possible and high design costs can be recovered quickly. The advantage of the microcomputer is that a standard device can be used for many applications merely by altering the program of instructions held in its memory. Thus design costs can be reduced and a variety of products may be built using perhaps a standard circuit board.

Microcomputers, however, bring with them a number of new design concepts which may be unfamiliar to the system designer used to working with conventional digital logic systems. In this introductory section we shall examine the internal organisation of microcomputer systems and their general principles of operation. Later we shall consider the various factors involved in choosing a suitable type of microprocessor for a design project.

ARCHITECTURE

The general organisation of a digital computer, whether it be a mainframe, a minicomputer or a microcomputer, follows the basic arrangement shown in fig. 1.1.

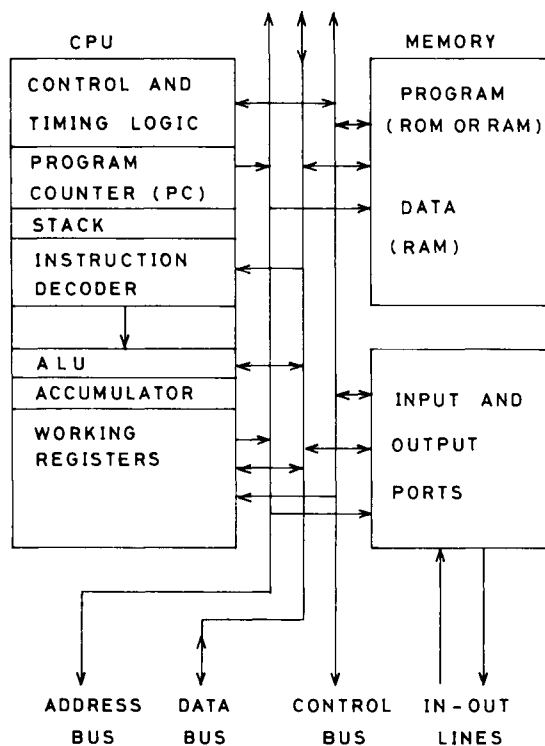

Fig. 1.1

At the heart of the system is the *central processor unit*, generally referred to as the CPU. Functionally the CPU can be broken down into two subsections, one of

which is used to control the timing and sequence of operations in the system, whilst the other executes the required arithmetic and logic operations and handles the data being processed. A memory system is connected to the CPU and is used to store the list of instructions to be executed, known as the *program*, and the data being processed. In most systems a common memory is used to hold both the program instructions and the data but some types of processor use separate memory systems for the data and the instructions. Communication with the outside world is handled by a number of *input* and *output* ports, which allow data to be transferred to and from external devices such as keyboards, display units and printers. The various components of the microcomputer system are tied together by a system of bus lines which are common to all units. This is, of course, a very much simplified description of a microcomputer system and we shall now go on to look at each section in more detail.

BUS SYSTEMS

Data is transferred between the various units of the system over sets of parallel wires known as *buses*. In most systems there are three sets of bus wires, one carrying data, a second carrying memory address information and the third carrying a selection of control signals.

The data bus allows signals representing either data or program instructions to be transferred between the CPU and either the memory or the input-output ports. This bus is always bidirectional and its operation is controlled by the CPU. Read and write control lines from the CPU determine the direction of data flow through the data bus so that when a write operation is performed the signals always flow from the CPU out to memory or I-O ports. A read operation causes signals to flow into the CPU from the memory or I-O port. Many processors, such as the Motorola types, use a single read/write (R/W) control line to control the direction of signal flow on the data bus with one state of the control line indicating a read operation and the other indicating a write operation. Other types, such as the Intel and Zilog processors, have separate read and write control lines. Normally the data bus is set up for read operations as a default condition. There may be several memory or I-O devices which can access the data bus but only one may be allowed to actually drive the bus lines at a time so the bus drive circuits are either tri-state or wired OR type circuits.

The address bus is used to provide an address signal which selects one particular location within the memory for connection to the data bus. The address bus lines are driven by output signals from the CPU. The address bus may also be used to select individual input or output channels where several are connected to the CPU system.

Some processors use separate memories to hold the program instructions and the data. In such a system there may be one data and address bus system for the instruction memory and a separate data and address bus scheme for the data memory. Another variation uses a common address bus with separate data buses for the instructions and data.

The control bus provides a selection of control signals

Explore Litigation Insights

Docket Alarm provides insights to develop a more informed litigation strategy and the peace of mind of knowing you're on top of things.

Real-Time Litigation Alerts



Keep your litigation team up-to-date with **real-time alerts** and advanced team management tools built for the enterprise, all while greatly reducing PACER spend.

Our comprehensive service means we can handle Federal, State, and Administrative courts across the country.

Advanced Docket Research



With over 230 million records, Docket Alarm's cloud-native docket research platform finds what other services can't. Coverage includes Federal, State, plus PTAB, TTAB, ITC and NLRB decisions, all in one place.

Identify arguments that have been successful in the past with full text, pinpoint searching. Link to case law cited within any court document via Fastcase.

Analytics At Your Fingertips



Learn what happened the last time a particular judge, opposing counsel or company faced cases similar to yours.

Advanced out-of-the-box PTAB and TTAB analytics are always at your fingertips.

API

Docket Alarm offers a powerful API (application programming interface) to developers that want to integrate case filings into their apps.

LAW FIRMS

Build custom dashboards for your attorneys and clients with live data direct from the court.

Automate many repetitive legal tasks like conflict checks, document management, and marketing.

FINANCIAL INSTITUTIONS

Litigation and bankruptcy checks for companies and debtors.

E-DISCOVERY AND LEGAL VENDORS

Sync your system to PACER to automate legal marketing.