

IN THE UNITED STATES PATENT AND TRADEMARK OFFICE

In re U.S. Patent Number: 7,374,758

(Application No. 11/016,503)

For: **Modified Chimeric Polypeptides with
Improved Pharmacokinetic Properties
and Methods of Using Thereof**

Inventors: Papadopoulos, Davis and Yancopoulos

Issued: May 20, 2008

Assignee: Regeneron Pharmaceuticals, Inc.

RECEIVED
DEC 22 2011
PATENT EXTENSION
Unit: OI/OPLA

Office of Patent Legal Administration (via hand delivery)
Room MDW 7D55
600 Dulany Street (Madison Building)
Alexandria, VA 22314

APPLICATION FOR EXTENSION OF PATENT TERM UNDER 35 U.S.C. §156

Dear Sir,

Applicant, Regeneron Pharmaceuticals, Inc., hereby submits this application for extension of the term of United States Letters Patent No. 7,374,758 (the "'758 patent") under 35 U.S.C. §156 and 37 C.F.R. §1.740.

Applicant represents that it is the assignee of the entire interest in and to the '758 patent by virtue of assignment of all rights of inventors Nicholas J. Papadopoulos, Samuel Davis and George D. Yancopoulos (Papadopoulos *et al.*) to Regeneron Pharmaceuticals, Inc., as recorded in the U.S. Patent and Trademark Office on December 17, 2004, Reel 016103, Frame 0015 (a copy of which is attached in Attachment A).

05/09/2012 CKHLOK 00000009 100650 11016503
01 FC:1457 1120.00 DA

This application is based on the approval by the United States Food and Drug Administration ("FDA") of a Biologics License Application (BLA No. BL 125387/0) on November 18, 2011, for EYLEA™ (aflibercept intravitreal injection, also known as aflibercept IVT, aflibercept ophthalmic injection and aflibercept ophthalmic solution).

1. Identification of the Approved Product under 37 C.F.R. §1.740 (a)(1)

The name of the approved product is EYLEA™. The name of the active ingredient of EYLEA™ is aflibercept, also known as VEGF trap, VEGF-trap, VEGF Trap-Eye and VEGF-TRAP_{R1R2}. Aflibercept is a fusion protein consisting of (a) a vascular endothelial growth factor (VEGF) receptor component having immunoglobulin-like (Ig) domains consisting of an Ig domain 2 of a first VEGF receptor that is human Flt1 and an Ig domain 3 of a second VEGF receptor that is human Flk1; and (b) an Fc portion of human IgG1.

2. Federal Statute Governing Regulatory Approval of the Approved Product under 37 C.F.R. §1.740(a)(2)

The approved product was subject to regulatory review under, *inter alia*, the Public Health Service Act (42 U.S.C. § 201 *et seq.*, including 42 U.S.C. §262(a)) and the Federal Food, Drug and Cosmetic Act (21 U.S.C. § 355 *et seq.*).

3. Date of Approval for Commercial Marketing under 37 C.F.R. §1.740 (a)(3)

EYLEA™ was approved for commercial marketing or use under §351 of the Public Health Service Act on November 18, 2011.

4. Identification of Active Ingredient and Certifications Related to Commercial Marketing of Approved Product under 37 C.F.R. §1.740(a)(4)

- (a) The active ingredient of EYLEA™ is aflibercept, which is a recombinant fusion protein consisting of a VEGF receptor component having Ig domains consisting of an Ig domain 2 of human Flt1 and an Ig domain 3 of human Flk1, fused to the Fc domain of human IgG1.
- (b) Applicant certifies that aflibercept has not been approved for commercial marketing or use under the Federal Food, Drug and Cosmetic Act, the Public Health Service Act or the Virus-Serum-Toxin Act prior to the approval granted on November 18, 2011 to the present Applicant.

- (c) Aflibercept has been approved for the treatment of patients with neovascular (wet) age-related macular degeneration. See EYLEA™ product label, provided as Attachment B.
- (d) EYLEA™, whose active ingredient is aflibercept, was approved for commercial marketing pursuant to § 351 of the Public Health Service Act (42 U.S.C. §262) under Regeneron's existing Department of Health and Human Services (DHHS) U.S. License No. 1760. See EYLEA™ approval letter, provided as Attachment C.

5. Statement Regarding Timeliness of Submission of Patent Term Extension Request [§ 1.740(a)(5)]

Applicant certifies that this application for patent term extension is being submitted within the sixty (60) day period permitted for submission specified in 35 U.S.C. § 156(d)(1), (as amended on September 16, 2011), and 37 C.F.R. § 1.720(f). The amended provisions of the America Invents Act state that the date on which a product receives permission is the next business day if permission is "transmitted after 4:30 P.M., Eastern Time, on a business day" Permission was transmitted at 5:47 P.M., Eastern Time, on Friday, November 18, 2011, a business day. The next business day is Monday, November 21, 2011. Accordingly, the last date on which this application may be submitted is January 19, 2012.

6. Complete Identification of the Patent for Which Extension Is Being Sought [§ 1.740(a)(6)]

The complete identification of the patent for which an extension is being sought is as follows:

- (a) Names of the inventors: Nicholas J. Papadopoulos, Samuel Davis and George D. Yancopoulos
- (b) Patent Number: U.S. Patent No. 7,374,758 (the "758 patent")
- (c) Date of Issue: May 20, 2008
- (d) Date of Expiration : January 17, 2021

7. Copy of the Patent for Which an Extension is Being Sought [§ 1.740(a)(7)]

A copy of the '758 patent is provided as Attachment D to the present application.

8. Copies of Disclaimers, Certificates of Correction, Receipt of Maintenance Fee Payment, or Reexamination Certificate [§ 1.740(a)(8)]

- (a) The '758 patent is subject to a terminal disclaimer, a copy of which is attached in Attachment E.
- (b) No certificate of correction has been issued for the '758 patent.
- (c) The first maintenance fee for the '758 patent was paid on November 14, 2011 (See Attachment F).
- (d) The '758 patent has not been the subject of a reexamination proceeding.

9. Statement Regarding Patent Claims Relative to Approved Product [§ 1.740(a)(9)]

The statements below are made solely to comply with the requirements of 37 C.F.R. § 1.740 (a)(9). Applicant notes that, as the M.P.E.P. acknowledges, § 1.740 (a)(9) does not require an applicant to show whether or how the listed claims would be infringed, and that this question cannot be answered without specific knowledge concerning acts performed by third parties. As such, these comments are not an assertion or an admission of Applicant as to the scope of the listed claims, or whether or how any of the listed claims would be infringed, literally or under the doctrine of equivalents, by the manufacture, use, sale, offer for sale or the importation of any product.

- (a) At least the following claims of the '758 patent claim a method of using the approved product: claims 1 and 2.
- (b) Pursuant to M.P.E.P. § 2753 and 37 C.F.R. § 1.740(a)(9), the following explanation is provided which shows how the above-listed claims of the '758 patent claim a method of using the approved product.
 - (1) *Description of the approved product*

The approved product is described as follows in the approved label for EYLEA™, a copy of which is provided as Attachment B.

EYLEA™ (aflibercept ophthalmic solution) is a recombinant fusion protein consisting of portions of human VEGF receptors 1 and 2 extracellular domains fused to the Fc portion of human IgG1 and specially purified and formulated as an iso-osmotic solution for intravitreal administration. Aflibercept is a dimeric glycoprotein with a protein molecular weight of 97 kilodaltons (kDa) and is glycosylated, with the glycosylation constituting an additional 15% of the total molecular mass, resulting in a total molecular weight of 115 kDa. Aflibercept is produced in Chinese hamster ovary (CHO) K1 cells by recombinant DNA technology.

EYLEA™ is a sterile, clear, and colorless to pale yellow, iso-osmotic solution. It is supplied as a preservative-free, sterile, aqueous solution in a single-use, sterile, pre-filled, glass syringe or single-use, glass vial designed to deliver 0.05 mL (50 microliters) of EYLEA™ (40 mg/mL) with 10 mM sodium phosphate, 40 mM sodium chloride, 0.03% polysorbate 20, and 5% sucrose, pH 6.2.

Aflibercept is also described in Holash *et al.* Proc. Natl. Acad. Sci. USA, August 20, 2002, Vol. 99, No. 17, pp. 11393-11398 ("Holash," Attachment G) as VEGF-Trap_{R1R2}, which has the Ig domain 2 of VEGF receptor 1 (VEGFR1; also known as Flt-1) fused to the Ig domain 3 of VEGF receptor 2 (VEGFR2; also known as Flk-1), which in turn is fused to the constant region (Fc) of human IgG1. See paragraph bridging pages 11393 and 11394 and Figure 1A. Moreover, Holash *et al.* demonstrate that aflibercept is a VEGF antagonist that binds to and inhibits the biologic activity of human vascular endothelial growth factor (VEGF) in various *in vitro* and *in vivo* assay systems.

(2) *Explanation Regarding Claims 1 and 2 Relative to Aflibercept*

As explained below, a method for using aflibercept, the active ingredient of the approved product, is covered by claims 1 and 2.

Claims 1 and 2 read as follows:

1. A method of inhibiting vascular endothelial growth factor (VEGF) activity in a mammal, comprising:
administering a pharmaceutical composition to the mammal, wherein the pharmaceutical composition comprises
(a) a VEGF antagonist, and

- (b) a pharmaceutically acceptable carrier wherein the VEGF antagonist comprises a dimeric fusion polypeptide comprising two fusion polypeptides, each fusion polypeptide comprising:
- (i) a VEGF receptor component consisting of an immunoglobulin-like (Ig) domain 2 of a first VEGF receptor human Flt1 and Ig domain 3 of a second VEGF receptor human Flk1 or human Flt4; and
 - (ii) a multimerizing component, wherein VEGF activity is inhibited.

2. The method of claim 1, wherein the mammal is a human.

Comparison of aflibercept to Claim 1

Aflibercept inhibits the activation of VEGF receptors by binding to VEGF and thus, is a VEGF antagonist as defined by claim 1. See section 12.1 of EYLEA™ label, provided as Attachment B, and as shown further, below. As noted above, aflibercept is a dimeric glycoprotein comprising recombinant fusion polypeptides, each of which consists of human VEGF receptors 1 and 2 extracellular domains fused to the Fc portion of human IgG1. See section 11 of EYLEA™ label. Aflibercept includes an Ig domain 2 from VEGFR1 fused to an Ig domain 3 from VEGFR2 as described in Holash (See Attachment G, paragraph bridging pages 11393 and 11394 and Figure 1A). The '758 patent refers to VEGFR-1 as Flt1 in column 25, line 57 and refers to VEGFR-2 as Flk1 in column 26, line 12. In addition, Holash discloses that VEGFR-1 is also known as Flt-1 and VEGFR-2 is also known as Flk-1. See Figure 1A of Holash. Thus, aflibercept has a VEGF receptor component consisting of an Ig domain 2 of a first VEGF receptor human Flt-1 and an Ig domain 3 of a second VEGF receptor human Flk-1 as defined in claim 1.

Holash further describes VEGFR1 and VEGFR2 on page 11393, in the second paragraph, as being "highly related transmembrane tyrosine kinases that use their ectodomains to bind VEGF." The disclosure of the Flt1 and Flk1 components in the approved product and the construction of the expression vector used in making the active ingredient in the approved product is discussed in the '758 patent in Example 20, column 29, lines 41-56. The amino acid sequence of both the Flt1 and Flk1 components of the approved product are disclosed in Figures 24A-24C. Flt1 Ig domain 2 spans amino acid residues 27 through 129 and Flk1 Ig domain 3 spans amino acid residues 130 through 231 of the fusion protein.

Aflibercept comprises the Fc domain of human IgG1 fused to the extracellular domains from the VEGF receptors. See section 11 of EYLEA™ label, provided as Attachment B. A “multimerizing component” of the fusion protein of claim 1 can comprise an immunoglobulin domain, such as the Fc domain of IgG. See col. 5, lines 42-46 and col. 7, lines 25-30 of the '758 patent. Thus, aflibercept also includes a multimerizing component as defined in claim 1. The multimerizing component of the fusion protein, the Fc region of human IgG, is referenced throughout the '758 patent. The disclosure of the Fc multimerizing component in the actual product is discussed in Example 20, column 29, lines 41-56, and its amino acid sequence is disclosed in Figures 24A-24C, from amino acid residue 232 through 458.

As described in Section 11 of the EYLEA™ label (Attachment B), EYLEA™, the approved product, is a pharmaceutical composition comprising aflibercept (*i.e.* VEGF antagonist) and an iso-osmotic aqueous solution (*i.e.* pharmaceutically acceptable carrier). As explained above, aflibercept is a dimeric protein comprising two fusion polypeptides, each of which comprises a VEGF receptor component consisting of an Ig domain 2 of a first VEGF receptor human Flt1 and Ig domain 3 of a second VEGF receptor human Flk1 and a multimerizing component. Thus, the approved product is a pharmaceutical composition administered to a mammal according to the method of claim 1.

Aflibercept thus meets all of the limitations of claim 1.

Aflibercept inhibits VEGF activity, as shown in various Examples throughout the '758 patent.

For example, aflibercept was able to block the ability of VEGF to activate its receptor *in vitro*. This was shown by the ability of aflibercept to block VEGF-induced VEGFR2 phosphorylation when added at a 1.5 fold molar excess when compared with added VEGF (See the '758 patent, Example 23, column 31, lines 21-67 and column 32, lines 1-10. See also Figure 25A-C and Figure 26A-B).

Aflibercept was also effective in blocking VEGF-induced cell proliferation in cells engineered to express a chimeric VEGFR2 receptor, which mediates a strong cell proliferation response to VEGF *in vitro* (See the '758 patent, Example 24, column 32, lines 12-51 and also Figure 27).

Furthermore, aflibercept was also effective in inhibition of tumor growth in mice (See the '758 patent, Example 30, column 36, lines 48-67 and column 37, lines 1-8 and also Figure 40).

The effect of aflibercept was also studied in the female

reproductive system using two different readouts to assess the effect of aflibercept on VEGF activity in rats. These are described in Example 31 of the '758 patent, column 38, lines 24-67.

In this study, pregnant mare's serum gonadotropin (PMSG) was injected subcutaneously to induce ovulation in pre-pubertal female rats. This results in a surge of estradiol after two days, which in turn causes an induction of VEGF in the uterus. This induction results in hyperpermeability of the uterus and an increase in uterine wet weight 6 hours later. The study was done to determine if aflibercept could block the effect of VEGF on uterine wet weight. The results demonstrated that injection of aflibercept resulted in about a 50% reduction in uterine wet weight. These results are shown in Figure 41.

The other assay measured the effect of aflibercept on VEGF-induced blood vessel formation in the corpus luteum. This allows for secretion of progesterone into the blood stream in order to prepare the uterus for implantation. If aflibercept was effective at blocking VEGF activity in this model, then the animals receiving aflibercept should show a reduction in progesterone in the blood stream. Injection of aflibercept at 25 mg/kg or 5 mg/kg at one hour after injection of PMSG resulted in complete inhibition of progesterone induction at day 4 (See Figure 42A-42B).

Comparison of aflibercept to Claim 2

According to the EYLEA™ label, provided as Attachment B, the approved product is intended for the treatment of human patients. In addition, the '758 patent, at column 6, lines 43-48, lines 52-54 and lines 60-61, discloses several embodiments in which aflibercept can be used in humans. For example, lines 43-48 described a method of decreasing or inhibiting plasma leakage in a mammal comprising administering the fusion polypeptide described, including embodiments wherein the mammal is a human. Lines 52-54 describe a preferred embodiment being a method of blocking blood vessel growth in a human comprising administering the fusion polypeptide of the invention. Lines 60-61 note that preferred embodiments of the methods are wherein the mammal is a human.

Aflibercept thus meets all of the limitations of claim 2.

Conclusion

Because aflibercept meets all of the limitations of claims 1 and 2 of the '758 patent, and because aflibercept is the active ingredient of EYLEA™, claims 1 and 2 of U.S. Patent No. 7,374,758 cover a method of

using the approved product.

10. Relevant Dates Under 35 U.S.C. § 156 for Determination of Applicable Regulatory Review Period [§ 1.740(a)(10)]

(a) Patent Issue Date

The '758 patent issued on May 20, 2008.

(b) IND Effective Date [35 U.S.C. § 156(g)(1)(B)(i); 37 C.F.R. § 1.740(a)(10)(i)(A)]

The date that an exemption under § 505(i) of the Federal Food, Drug and Cosmetic Act became effective (*i.e.*, the date that an investigational new drug application ("IND") became effective) for EYLEA™ (referred to in the IND-receipt letter as "Vascular Endothelial Growth Factor Fc Protein (human, recombinant, CHO cells, Regeneron)") was June 15, 2005. The application date for this IND was May 13, 2005. The IND was assigned number BB-IND # 12462. A copy of the letter from the FDA reflecting the IND's number, date of submission and date of receipt is provided in Attachment H.

(c) BLA Submission Date [35 U.S.C. § 156(g)(1)(B)(i); 37 C.F.R. § 1.740(a)(10)(i)(B)]

The BLA was submitted on February 17, 2011 and received by the FDA on February 18, 2011, as shown in Attachment I. The BLA was assigned number BL 125387/0.

(d) BLA Issue Date [35 U.S.C. § 156(g)(1)(B)(ii); 37 C.F.R. § 1.740(a)(10)(i)(C)]

The FDA approved biologic license application 125387/0 authorizing the marketing of EYLEA™ on November 18, 2011. EYLEA™ was approved under Department of Health and Human Services (DHHS) U.S. License No. 1760. A copy of the approval letter from the FDA is provided as Attachment C.

**11. Summary of Significant Events During Regulatory Review Period
[§1.740(a)(11)]**

Pursuant to 37 C.F.R. § 1.740(a)(11), the following provides a brief description of the activities of Regeneron Pharmaceuticals, Inc., before the FDA in relation to the regulatory review of EYLEA™. The brief description lists the significant events that occurred during the regulatory review period for the approved product. In several instances, communications to or from the FDA are referenced. Pursuant to 37 C.F.R. § 1.740(a)(11), 21 C.F.R. § 60.20(a), and M.P.E.P. § 2753, copies of such communications are not provided in this application, but can be obtained from records maintained by the FDA.

On May 13, 2005 Regeneron submitted to FDA an investigational new drug application for a recombinant fusion protein (originally vascular endothelial growth factor Fc protein, now aflibercept) consisting of (a) a vascular endothelial growth factor (VEGF) receptor component having immunoglobulin-like (Ig) domains consisting of an Ig domain 2 of a first VEGF receptor that is human Flt1 and an Ig domain 3 of a second VEGF receptor that is human Flk1; and (b) an Fc portion of human IgG1. The fusion protein was developed as a potential new therapeutic for intravitreal administration for treating (wet) age-related macular degeneration.

On June 15, 2005, BB-IND #12462 became effective via a communication mailed to Regeneron on May 24, 2005, (see Attachment H). According to the FDA, initiation of trials could begin 30 days after May 16, 2005.

From approximately July 2005 until approximately June 2008, a series of U.S. Phase I and II clinical trials were conducted. In addition, an extension trial is ongoing as of the date of this application.

Between approximately July 2007 and July 2011, Phase III clinical trials were conducted. In addition, an extension trial is ongoing as of the date of this application.

On June 1, 2009, representatives of Regeneron and CBER participated in a Type C meeting to seek agency agreement on the pharmacology/toxicology program for aflibercept.

On September 15, 2009, representatives of Regeneron and CBER participated in a Type C meeting to review the status and development of pre-filled syringes as the intended container-closure device to support commercialization of aflibercept.

On September 8, 2010, representatives of Regeneron and CBER participated in a Type B pre-BLA submission meeting to discuss and review clinical results of trials conducted prior to that date.

On September 27, 2010, representatives of Regeneron and CBER participated in a Type B pre-BLA submission meeting to discuss information and requirements for the chemical, manufacturing and control (CMC) chapter of the BLA.

On April 15, 2011, FDA granted priority review for aflibercept for AMD.

On November 18, 2011, FDA approved BLA No. BL 125387/0, issuing marketing authorization for EYLEA™. (See Attachment C.)

12. Statement Concerning Eligibility for and Duration of Extension Sought Under 35 U.S.C. § 156 [37 C.F.R § 1.740(a)(12)]

(a) In the opinion of the Applicant, U.S. Patent No. 7,374,758 is eligible for an extension under § 156 because:

(i) one or more claims of the '758 patent claim a method of using the approved product;

(ii) the term of the '758 patent has not been previously extended on the basis of § 156;

(iii) the '758 patent has not expired;

(iv) no other patent has been extended pursuant to § 156 on the basis of the regulatory review process associated with the approved product, EYLEA™ ;

(v) there is an eligible period of regulatory review by which the patent may be extended pursuant to § 156;

(vi) the applicant for marketing approval exercised due diligence within the meaning of § 156(d)(3) during the period of regulatory review;

(vii) the present application has been submitted within the 60-day period following the approval date of the approved product, pursuant to § 156(c); and

(viii) this application otherwise complies with all requirements of 35 U.S.C. § 156 and applicable rules and procedures.

(b) The period by which the term of the '758 patent is requested by Applicant to be extended is 775 days.

(c) The requested period of extension of term for the '758 patent corresponds to the regulatory review period that is eligible for extension pursuant to §156, based on the facts and circumstances of the regulatory review associated with the approved product EYLEA™. The period was determined as follows.

(i) The relevant dates for calculating the regulatory review period, based on the events discussed in the section above, are the following.

Exemption under FDCA § 505(i) became effective June 15, 2005 (30 days after FDA receipt of the IND on May 16, 2005)

Patent was granted May 20, 2008

Biologics License Application (BLA) under PHSA § 351 was filed February 17, 2011

BLA was approved November 18, 2011

(ii) The '758 patent was granted during the period specified in §156(g)(1)(B)(i) (*i.e.*, the period from the date of the grant of the exemption under § 505(i) of the FDCA until the date of submission of the BLA). Pursuant to § 156(b) and (c)(2), the calculated regulatory review period includes a component equal to half of the number of days within that period that are after the grant of the patent (1/2 of 1002, or 501 days).

(iii) Because the patent was granted before the start of the period specified in § 156(g)(1)(B)(ii) (*i.e.*, the period from the date of submission of the BLA until the date of approval), the regulatory review period under § 156(b) includes a component equal to the total number of days in that period (274 days).

(iv) The '758 patent will expire on January 17, 2021 taking into account the Terminal Disclaimer (*See Attachment E*).

(v) Taking into account the 501 days specified in (ii) above, which accounts for the time period between the date of grant of the exemption under § 505(i) of the FDCA until the date of submission of the BLA), and further pursuant to § 156(b) and (c)(2), whereby the calculated regulatory review period includes a component equal to half of the number of days within that period that are after the grant of the patent, plus the 274 days specified in the regulatory review period under § 156(b) and noted in (iii) above, which includes the number of days from the date of submission of the BLA until the date of approval, the total number of days to be included for consideration of patent term extension is believed to be 775 days.

(vi) The date of approval of the approved product is November 18, 2011.

(vii) The date that is fourteen years from the date of approval of the approved product is November 18, 2025.

(viii) The addition of 775 days to the time of patent expiry (which includes the period disclaimed via the terminal disclaimer) brings the projected patent expiry date to March 3, 2023. The date until the end of the fourteen-year period specified in §156(c)(3) is November 18, 2025. Accordingly, the projected date of expiration taking into account the 775 day patent term extension does not exceed the date projected to be 14 years beyond the date of BLA approval. As such, the period by which the patent may be extended is not limited by the fourteen-year rule of § 156(c)(3).

(ix) The '758 patent issued after the effective date of Public Law No. 98-417. As such, the two- or three -year limit of 35 U.S.C. § 156(g)(6)(C) does not apply.

13. Statement Pursuant to 37 C.F.R. § 1.740(a)(13)

Pursuant to 37 C.F.R. § 1.740(a)(13), Applicant acknowledges its duty to disclose to the Director of the PTO and to the Secretary of Health and Human Services any information which is material to the determination of entitlement to the extension sought, particularly as that duty is defined in 37 C.F.R. § 1.765. In furtherance of this duty, Applicant wishes to inform the Director and Secretary that concurrently with the present Application for Extension of Patent Term Under 35 U.S.C. §156 Applicant has filed an Application for Extension of Patent Term Under 35 U.S.C. §156 (plus two copies) in connection with U.S. Patent Nos. 7,374,757 and 7,070,959.

14. Applicable Fee [§ 1.740(a)(14)]

Please deduct all fees necessary pursuant to 37 C.F.R. §1.20(j) corresponding to the fee for a patent term extension application under 35 U.S.C. § 156 from deposit account no. 18-0650. Please deduct any additional fee or fees deemed necessary in excess of this amount from our deposit account no. 18-0650.

15. Name and Address for Correspondence [§ 1.740(a)(15)]

Please direct all inquiries, questions, and communications regarding this application for term extension to :

Valeta Gregg, Ph.D., J.D.
Vice President and Assistant General Counsel, Patents
Regeneron Pharmaceuticals, Inc.
777 Old Saw Mill River Rd.
Tarrytown, NY 10591-6707
Tel. 914-847-1077
Fax 914-847-7705
email: valeta.gregg@regeneron.com



U.S. Patent No. 7,374,758
Papadopoulos, *et al.*
Application Under 35 U.S.C. § 156

Page 16

Two additional copies of this application are enclosed, in compliance with 37 C.F.R. § 1.740(b).

Sincerely,

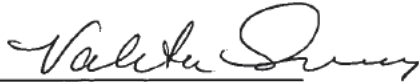

Attorney/Agent for Applicant

Registration No. 35,127

Dated: 21 Dec 2011

Index of Attachments

Attachment A – Copy of Assignment of U.S. Patent No. 7,374,758

Attachment B – Copy of EYLEA™ Product Label

Attachment C – Copy of EYLEA™ BLA Approval letter from the FDA

Attachment D – Copy of U.S. Patent No. 7,374,758

Attachment E – Copy of Terminal Disclaimer for U.S. Patent No. 7,374,758

Attachment F – Copy of Maintenance Fee Statement for U.S. Patent No. 7,374,758

Attachment G – Copy of Holash *et al.* PNAS 99(17):11393-11398 (2002)

Attachment H – Copy of IND-receipt letter from FDA

Attachment I – Copy of BLA Submission acknowledgement letter from FDA

ATTACHMENT A

Copy of Assignment of U.S. Patent No.

7,374,758

12-17-04

12-30-2004

Form PTO-1595 (Rev. 10/02) OMB No. 0651-0027 (exp. 6/30/2005) Tab settings



102914790

U.S. DEPARTMENT OF COMMERCE U.S. Patent and Trademark Office

U.S. PTO 11/016503



To the Honorable Commissioner of Patents and Trademarks: Please record the attached original documents or copy thereof.

1. Name of conveying party(ies): Nicholas J. Papadopoulos Samuel Davis George D. Yancopoulos Additional name(s) of conveying party(ies) attached? Yes No

2. Name and address of receiving party(ies) Name: Regeneron Pharmaceuticals, Inc. Internal Address: Street Address: 777 Old Saw Mill River Road City: Tarrytown State: NY Zip: 10591 Additional name(s) & address(es) attached? Yes No

3. Nature of conveyance: [X] Assignment [] Merger [] Security Agreement [] Change of Name [] Other Execution Date: February 4, 2002

4. Application number(s) or patent number(s): If this document is being filed together with a new application, the execution date of the application is: 2/4/02 A. Patent Application No.(s) B. Patent No.(s) Additional numbers attached? Yes No

5. Name and address of party to whom correspondence concerning document should be mailed: Name: Valeta Gregg Internal Address: Regeneron Pharmaceuticals, Inc Street Address: 777 Old Saw Mill River Road City: Tarrytown State: NY Zip: 10591

6. Total number of applications and patents involved: 1 7. Total fee (37 CFR 3.41).....\$ 40.00 [] Enclosed [X] Authorized to be charged to deposit account 8. Deposit account number: 18-0650

DO NOT USE THIS SPACE

9. Signature. Valeta Gregg Name of Person Signing December 17, 2004 Date Signature Total number of pages including cover sheet, attachments, and documents: 4

12/29/2004 6TON11 00000175 180650 11016503 01 FC:6021 40.00 BA

Mail documents to be recorded with required cover sheet information to: Commissioner of Patents & Trademarks, Box Assignments Washington, D.C. 20231

PATENT REEL: 016103 FRAME: 0015

ASSIGNMENT

WHEREAS, We, Nicholas J. Papadopoulos, residing at 59 Heritage Lane, Lagrangeville, New York 12540, a citizen of the United States of America, Samuel Davis, residing at 332 W. 88th Street #B2, New York, New York 10024, a citizen of the United States of America, and George D. Yancopoulos, residing at 1519 Baptist Church Road, Yorktown Heights, New York 10598, a citizen of the United States of America (HEREINAFTER CALLED "ASSIGNORS") are inventor(s) of the invention(s) disclosed and/or claimed in the following patent application:

USSN 10/009,852 filed December 6, 2001,

which is the national stage filing of PCT/US00/14142 filed June 8, 1999;

WHEREAS, REGENERON PHARMACEUTICALS INC., a corporation organized and existing under the laws of the State of New York, with offices at 777 Old Saw Mill River Road, Tarrytown, New York 10591-6707, U.S.A. (HEREINAFTER called "ASSIGNEE") is desirous of acquiring our entire right, title and interest in, to, and under the said applications;

NOW, THEREFORE, in consideration of the sum of One Dollar (\$1.00) to us in hand paid, and other good and valuable consideration, the receipt of which is hereby acknowledged, We, the said ASSIGNORS, have sold, assigned, transferred and set over, and by these presents do hereby sell, assign, transfer and set over unto the said ASSIGNEE, its successors, legal representatives, and assigns, our entire right, title and interest for all countries in and to any and all inventions which are disclosed and claimed, and any and all inventions which are disclosed but not claimed in the above-described United States applications, and in and to said United States Applications and all divisions, renewals, continuations, and continuations-in-part thereof, and all Patents of the United States which may be granted thereon and all reissues and extensions thereof; and all applications for industrial property protection, including, without limitation, all applications for patents utility models, and designs which may hereafter be filed for said inventions in any country or countries foreign to the United States, together with the right to file such applications and the right to claim for the same the priority rights derived from said United States applications under the Patent Laws of the United States, the International Convention of 1883 and later modifications thereof, under the Patent Cooperation Treaty, under the European Patent Convention, or under any other available international agreement or under the domestic laws of the country in which any such application is filed, as may be applicable; and all forms of industrial property protection, including, without limitation, patents, utility models, inventors' certificates and designs which may be granted for said inventions in any country or countries foreign to the United States and all extensions, renewals and reissues thereof;

AND WE HEREBY authorize and request the Commissioner of Patents and Trademarks of the United States and any Official of any country or countries foreign to the United States

PATENT
REEL: 016103 FRAME: 0016

whose duty it is to issue patents or other evidence or forms of industrial property protection on applications as aforesaid, to issue the same to the said ASSIGNEE, their successors, legal representatives and assigns, in accordance with this instrument;

AND WE HEREBY covenant and agree that WE have full right to convey the entire interest HEREINAFTER assigned, and that WE have not executed, and will not execute, any agreement in conflict herewith;

AND WE HEREBY further covenant and agree that WE will communicate to the said ASSIGNEE, its successors, legal representatives and assigns, any facts known to us respecting said inventions, and testify in any legal proceeding, sign all lawful papers, execute all divisional, continuing, continuation-in-part, reissue and foreign applications, make all rightful oaths, and generally do everything possible to aid the said ASSIGNEE, its successors, legal representatives and assigns, to obtain and enforce proper protection for said inventions in all countries.

IN TESTIMONY HEREOF, WE hereunto set our hands and seals the day and year set opposite our signatures.

Dated: 2/4/02

L.S.
Nicholas J. Papadopoulos

State of New York
County of Westchester S.S.

On this 4th day February 2002, before me, Bernadette B. Fahey, a Notary Public in and for the State and County aforesaid, personally appeared Nicholas J. Papadopoulos, to me known, and to me known to be the person of that name, who signed and sealed the foregoing instrument, and acknowledged the same to be his free act and deed.

Notary Public

BERNADETTE B. FAHEY
Notary Public, State of New York
No. 01FA0035879
Qualified in Putnam County
Commission Expires January 10, 2006

PATENT
REEL: 016103 FRAME: 0017

Dated: 2/4/02

Samuel Davis L.S.
Samuel Davis

State of New York
S.S.
County of Westchester

On this 4th day February 2002, before me, Bernadette B. Fahey, a Notary Public in and for the State and County aforesaid, personally appeared Samuel Davis, to me known, and to me known to be the person of that name, who signed and sealed the foregoing instrument, and acknowledged the same to be his free act and deed.

BERNADETTE B. FAHEY
Notary Public, State of New York
No. 01FA6035879
Qualified in Putnam County
Commission Expires January 10, 2006

Bernadette B. Fahey
Notary Public

Dated: 2/4/02

George D. Yancopoulos L.S.
George D. Yancopoulos

State of New York
S.S.
County of Westchester

On this 4th day February 2002, before me, Bernadette B. Fahey, a Notary Public in and for the State and County aforesaid, personally appeared George D. Yancopoulos, to me known, and to me known to be the person of that name, who signed and sealed the foregoing instrument, and acknowledged the same to be his free act and deed.

Bernadette B. Fahey
Notary Public

BERNADETTE B. FAHEY
Notary Public, State of New York
No. 01FA6035879
Qualified in Putnam County
Commission Expires January 10, 2006

RECORDED: 12/17/2004

PATENT
REEL: 016103 FRAME: 0018

ATTACHMENT B

Copy of EYLEA™

Product Label

HIGHLIGHTS OF PRESCRIBING INFORMATION

These highlights do not include all the information needed to use EYLEA safely and effectively. See full prescribing information for EYLEA.

EYLEA™ (aflibercept) Injection
For Intravitreal Injection
Initial U.S. Approval: 2011

INDICATIONS AND USAGE

EYLEA is indicated for the treatment of patients with Neovascular (Wet) Age-Related Macular Degeneration (AMD). (1)

DOSAGE AND ADMINISTRATION

- For ophthalmic intravitreal injection only. (2.1)
- The recommended dose for EYLEA is 2 mg (0.05 mL) administered by intravitreal injection every 4 weeks (monthly) for the first 3 months, followed by 2 mg (0.05 mL) via intravitreal injection once every 8 weeks (2 months). (2.2)
- Although EYLEA may be dosed as frequently as 2 mg every 4 weeks (monthly), additional efficacy was not demonstrated when EYLEA was dosed every 4 weeks compared to every 8 weeks. (2.2)

DOSAGE FORMS AND STRENGTHS

40 mg/mL solution for intravitreal injection in a single-use vial (3)

CONTRAINDICATIONS

- Ocular or periocular infection (4.1)
- Active intraocular inflammation (4.2)
- Hypersensitivity (4.3)

WARNINGS AND PRECAUTIONS

- Endophthalmitis and retinal detachments may occur following intravitreal injections. Patients should be instructed to report any symptoms suggestive of endophthalmitis or retinal detachment without delay and should be managed appropriately. (5.1)
- Increases in intraocular pressure have been seen within 60 minutes of an intravitreal injection. (5.2)

ADVERSE REACTIONS

The most common adverse reactions (≥5%) reported in patients receiving EYLEA were conjunctival hemorrhage, eye pain, cataract, vitreous detachment, vitreous floaters, and increased intraocular pressure. (6.2)

To report SUSPECTED ADVERSE REACTIONS, contact Regeneron at 1-855-395-3248 or FDA at 1-800-FDA-1088 or www.fda.gov/medwatch.

See 17 for PATIENT COUNSELING INFORMATION.

Revised: 11/2011

FULL PRESCRIBING INFORMATION: CONTENTS*

1	INDICATIONS AND USAGE
2	DOSAGE AND ADMINISTRATION
2.1	General Dosing Information
2.2	Dosing
2.3	Preparation for Administration
2.4	Administration
3	DOSAGE FORMS AND STRENGTHS
4	CONTRAINDICATIONS
4.1	Ocular or Periocular Infections
4.2	Active Intraocular Inflammation
4.3	Hypersensitivity
5	WARNINGS AND PRECAUTIONS
5.1	Endophthalmitis and Retinal Detachments
5.2	Increase in Intraocular Pressure
5.3	Thromboembolic Events
6	ADVERSE REACTIONS
6.1	Injection Procedure
6.2	Clinical Studies Experience

6.3	Immunogenicity
8	USE IN SPECIFIC POPULATIONS
8.1	Pregnancy
8.3	Nursing Mothers
8.4	Pediatric Use
8.5	Geriatric Use
11	DESCRIPTION
12	CLINICAL PHARMACOLOGY
12.1	Mechanism of Action
12.2	Pharmacodynamics
12.3	Pharmacokinetics
13	NONCLINICAL TOXICOLOGY
13.1	Carcinogenesis, Mutagenesis, Impairment of Fertility
13.2	Animal Toxicology and/or Pharmacology
14	CLINICAL STUDIES
16	HOW SUPPLIED/STORAGE AND HANDLING
17	PATIENT COUNSELING INFORMATION

*Sections or subsections omitted from the full prescribing information are not listed.

FULL PRESCRIBING INFORMATION

1 INDICATIONS AND USAGE

EYLEA is indicated for the treatment of patients with Neovascular (Wet) Age-Related Macular Degeneration (AMD).

2 DOSAGE AND ADMINISTRATION

2.1 General Dosing Information

FOR OPHTHALMIC INTRAVITREAL INJECTION ONLY. EYLEA must only be administered by a qualified physician.

2.2 Dosing

The recommended dose for EYLEA is 2 mg (0.05 mL or 50 microliters) administered by intravitreal injection every 4 weeks (monthly) for the first 12 weeks (3 months), followed by 2 mg (0.05 mL) via intravitreal injection once every 8 weeks (2 months). Although EYLEA may be dosed as frequently as 2 mg every 4 weeks (monthly), additional efficacy was not demonstrated when EYLEA was dosed every 4 weeks compared to every 8 weeks [*see Clinical Studies (14)*].

2.3 Preparation for Administration

EYLEA should be inspected visually prior to administration. If particulates, cloudiness, or discoloration are visible, the vial must not be used.

Using aseptic technique, the intravitreal injection should be performed with a 30-gauge x ½-inch injection needle.

Vial

The glass vial is for single use only.

1. Remove the protective plastic cap from the vial (see Figure 1).

Figure 1:

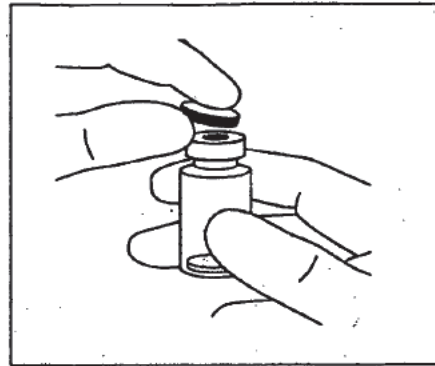

2. Clean the top of the vial with an alcohol wipe (see Figure 2).

Figure 2:

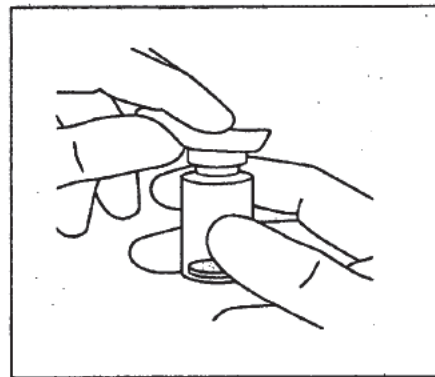

3. Remove the 19-gauge x 1½-inch, 5-micron, filter needle from its pouch and remove the 1-mL syringe supplied in the carton from its pouch. Attach the filter needle to the syringe by twisting it onto the Luer lock syringe tip (see Figure 3).

Figure 3:

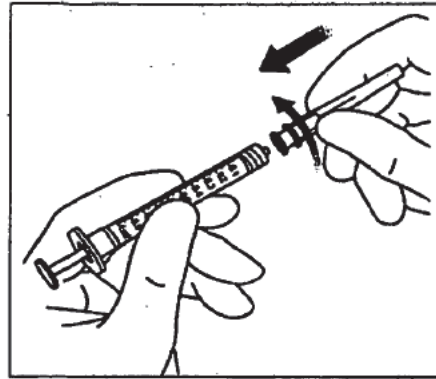

4. Push the filter needle into the center of the vial stopper until the needle touches the bottom edge of the vial.
5. Using aseptic technique withdraw all of the EYLEA vial contents into the syringe, keeping the vial in an upright position, slightly inclined to ease complete withdrawal (see Figure 4).

Figure 4:

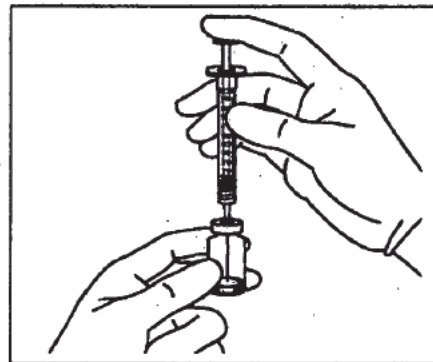

6. Ensure that the plunger rod is drawn sufficiently back when emptying the vial in order to completely empty the filter needle.
7. Remove the filter needle from the syringe and properly dispose of the filter needle.
Note: Filter needle is not to be used for intravitreal injection.
8. Remove the 30-gauge x 1/2-inch injection needle from the plastic pouch and attach the injection needle to the syringe by firmly twisting the injection needle onto the Luer lock syringe tip (see Figure 5).

Figure 5:

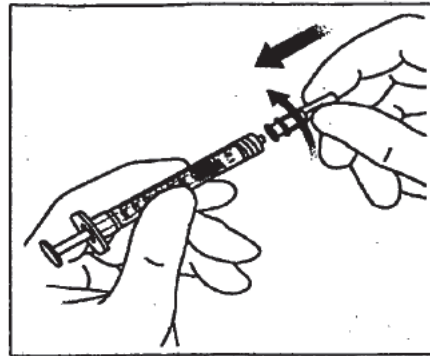

9. When ready to administer EYLEA, remove the plastic needle shield from the needle.
10. Holding the syringe with the needle pointing up, check the syringe for bubbles. If there are bubbles, gently tap the syringe with your finger until the bubbles rise to the top (see Figure 6).

Figure 6:

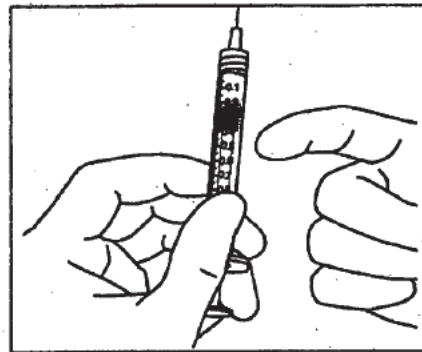

11. To eliminate all of the bubbles and to expel excess drug, **SLOWLY** depress the plunger so that the plunger tip aligns with the line that marks 0.05 mL on the syringe (see Figures 7 and 8).

Figure 7:

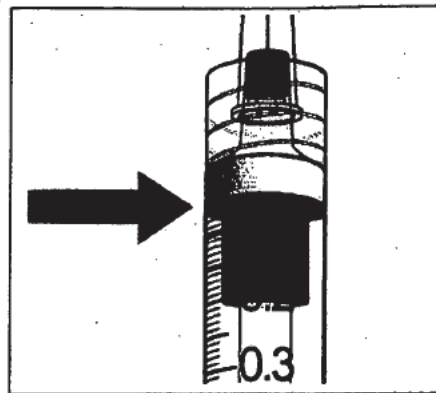
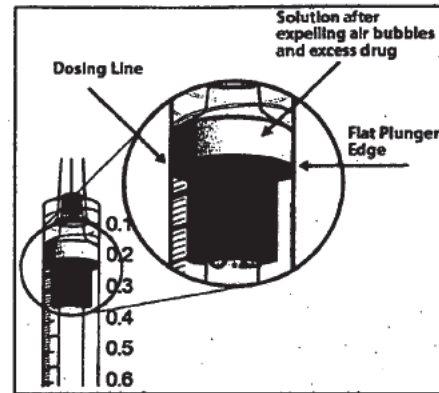

Figure 8:



2.4 Administration

The intravitreal injection procedure should be carried out under controlled aseptic conditions, which include surgical hand disinfection and the use of sterile gloves, a sterile drape, and a sterile eyelid speculum (or equivalent). Adequate anesthesia and a topical broad-spectrum microbicide should be given prior to the injection.

Immediately following the intravitreal injection, patients should be monitored for elevation in intraocular pressure. Appropriate monitoring may consist of a check for perfusion of the optic nerve head or tonometry. If required, a sterile paracentesis needle should be available.

Following intravitreal injection, patients should be instructed to report any symptoms suggestive of endophthalmitis or retinal detachment (e.g., eye pain, redness of the eye, photophobia, blurring of vision) without delay [see *Patient Counseling Information (17)*].

Each vial should only be used for the treatment of a single eye. If the contralateral eye requires treatment, a new vial should be used and the sterile field, syringe, gloves, drapes, eyelid speculum, filter, and injection needles should be changed before EYLEA is administered to the other eye.

After injection, any unused product must be discarded.

No special dosage modification is required for any of the populations that have been studied (e.g., gender, elderly).

3 DOSAGE FORMS AND STRENGTHS

Single-use, glass vial designed to provide 0.05 mL of 40 mg/mL solution for intravitreal injection.

4 CONTRAINDICATIONS

4.1 Ocular or Periocular Infections

EYLEA is contraindicated in patients with ocular or periocular infections.

4.2 Active Intraocular Inflammation

EYLEA is contraindicated in patients with active intraocular inflammation.

4.3 Hypersensitivity

EYLEA is contraindicated in patients with known hypersensitivity to aflibercept or any of the excipients in EYLEA.

5 WARNINGS AND PRECAUTIONS

5.1 Endophthalmitis and Retinal Detachments

Intravitreal injections, including those with EYLEA, have been associated with endophthalmitis and retinal detachments [*see Adverse Reactions (6.1)*]. Proper aseptic injection technique must always be used when administering EYLEA. Patients should be instructed to report any symptoms suggestive of endophthalmitis or retinal detachment without delay and should be managed appropriately [*see Dosage and Administration (2.4) and Patient Counseling Information (17)*].

5.2 Increase in Intraocular Pressure

Acute increases in intraocular pressure have been seen within 60 minutes of intravitreal injection, including with EYLEA [*see Adverse Reactions (6.1)*]. Sustained increases in intraocular pressure have also been reported after repeated intravitreal dosing with VEGF inhibitors. Intraocular pressure and the perfusion of the optic nerve head should be monitored and managed appropriately [*see Dosage and Administration (2.4)*].

5.3 Thromboembolic Events

There is a potential risk of arterial thromboembolic events (ATEs) following intravitreal use of VEGF inhibitors, including EYLEA. ATEs are defined as nonfatal stroke, nonfatal myocardial infarction, or vascular death (including deaths of unknown cause). The incidence in the VIEW1 and VIEW2 wet AMD studies during the first year was 1.8% (32 out of 1824) in the combined group of patients treated with EYLEA [*see Clinical Studies (14)*].

6 ADVERSE REACTIONS

The following adverse reactions are discussed in detail in other sections of the labeling:

- Endophthalmitis and retinal detachments [see *Warnings and Precautions (5.1)*]
- Increased intraocular pressure [see *Warnings and Precautions (5.2)*]
- Thromboembolic events [see *Warnings and Precautions (5.3)*]

The most common adverse reactions ($\geq 5\%$) reported in patients receiving EYLEA were conjunctival hemorrhage, eye pain, cataract, vitreous detachment, vitreous floaters, and increased intraocular pressure.

6.1 Injection Procedure

Serious adverse reactions related to the injection procedure have occurred in $<0.1\%$ of intravitreal injections with EYLEA including endophthalmitis, traumatic cataract, and increased intraocular pressure.

6.2 Clinical Studies Experience

Because clinical trials are conducted under widely varying conditions, adverse reaction rates observed in the clinical trials of a drug cannot be directly compared to rates in the clinical trials of another drug and may not reflect the rates observed in practice.

The data described below reflect exposure to EYLEA in 1824 patients with wet AMD, including 1223 patients treated with the 2-mg dose, in 2 double-masked, active-controlled clinical studies (VIEW1 and VIEW2) for 12 months [see *Clinical Studies (14)*].

Table 1: Most Common Adverse Reactions ($\geq 1\%$) in Phase 3 wet AMD studies

Adverse Reactions	EYLEA (N=1824)	Active Control (ranibizumab) (N=595)
Conjunctival hemorrhage	25%	28%
Eye pain	9%	9%
Cataract	7%	7%
Vitreous detachment	6%	6%
Vitreous floaters	6%	7%
Intraocular pressure increased	5%	7%
Conjunctival hyperemia	4%	8%
Corneal erosion	4%	5%

Adverse Reactions	EYLEA (N=1824)	Active Control (ranibizumab) (N=595)
Detachment of the retinal pigment epithelium	3%	3%
Injection site pain	3%	3%
Foreign body sensation in eyes	3%	4%
Lacrimation increased	3%	1%
Vision blurred	2%	2%
Retinal pigment epithelium tear	2%	1%
Injection site hemorrhage	1%	2%
Eyelid edema	1%	2%
Corneal edema	1%	1%

Less common serious adverse reactions reported in <1% of the patients treated with EYLEA were retinal detachment, retinal tear, and endophthalmitis. Hypersensitivity has also been reported in less than 1% of the patients treated with EYLEA.

6.3 Immunogenicity

As with all therapeutic proteins, there is a potential for an immune response in patients treated with EYLEA. The immunogenicity of EYLEA was evaluated in serum samples. The immunogenicity data reflect the percentage of patients whose test results were considered positive for antibodies to EYLEA in immunoassays. The detection of an immune response is highly dependent on the sensitivity and specificity of the assays used, sample handling, timing of sample collection, concomitant medications, and underlying disease. For these reasons, comparison of the incidence of antibodies to EYLEA with the incidence of antibodies to other products may be misleading.

In the phase 3 studies, the pre-treatment incidence of immunoreactivity to EYLEA was 1% to 3% across treatment groups. After dosing with EYLEA for 52 weeks, antibodies to EYLEA were detected in a similar percentage range of patients. There were no differences in efficacy or safety between patients with or without immunoreactivity.

8 USE IN SPECIFIC POPULATIONS

8.1 Pregnancy

Pregnancy Category C. Aflibercept produced embryo-fetal toxicity when administered during organogenesis in pregnant rabbits at intravenous doses of 3 to 60 mg/kg. A series of external, visceral, and skeletal malformations were observed in the fetuses. The maternal No Observed

Adverse Effect Level (NOAEL) was 3 mg/kg, whereas the fetal NOAEL was below 3 mg/kg. At this dose, the systemic exposures based on C_{max} and AUC for free aflibercept were approximately 2900 times and 600 times higher, respectively, when compared to corresponding values observed in humans after an intravitreal dose of 2 mg.

There are no adequate and well-controlled studies in pregnant women. EYLEA should be used during pregnancy only if the potential benefit justifies the potential risk to the fetus.

8.3 Nursing Mothers

It is unknown whether aflibercept is excreted in human milk. Because many drugs are excreted in human milk, a risk to the breastfed child cannot be excluded. EYLEA is not recommended during breastfeeding. A decision must be made whether to discontinue nursing or to discontinue treatment with EYLEA, taking into account the importance of the drug to the mother.

8.4 Pediatric Use

The safety and effectiveness of EYLEA in pediatric patients have not been established.

8.5 Geriatric Use

In the clinical studies, approximately 89% (1616/1817) of patients randomized to treatment with EYLEA were ≥ 65 years of age and approximately 63% (1139/1817) were ≥ 75 years of age. No significant differences in efficacy or safety were seen with increasing age in these studies.

11 DESCRIPTION

EYLEA (aflibercept) is a recombinant fusion protein consisting of portions of human VEGF receptors 1 and 2 extracellular domains fused to the Fc portion of human IgG1 formulated as an iso-osmotic solution for intravitreal administration. Aflibercept is a dimeric glycoprotein with a protein molecular weight of 97 kilodaltons (kDa) and contains glycosylation, constituting an additional 15% of the total molecular mass, resulting in a total molecular weight of 115 kDa. Aflibercept is produced in recombinant Chinese hamster ovary (CHO) cells.

EYLEA is a sterile, clear, and colorless to pale yellow solution. EYLEA is supplied as a preservative-free, sterile, aqueous solution in a single-use, glass vial designed to deliver 0.05 mL (50 microliters) of EYLEA (40 mg/mL in 10 mM sodium phosphate, 40 mM sodium chloride, 0.03% polysorbate 20, and 5% sucrose, pH 6.2).

12 CLINICAL PHARMACOLOGY

12.1 Mechanism of Action

Vascular endothelial growth factor-A (VEGF-A) and placental growth factor (PlGF) are members of the VEGF family of angiogenic factors that can act as mitogenic, chemotactic, and vascular permeability factors for endothelial cells. VEGF acts via two receptor tyrosine kinases, VEGFR-1 and VEGFR-2, present on the surface of endothelial cells. PlGF binds only to VEGFR-1, which is also present on the surface of leucocytes. Activation of these receptors by VEGF-A can result in neovascularization and vascular permeability.

Aflibercept acts as a soluble decoy receptor that binds VEGF-A and PlGF, and thereby can inhibit the binding and activation of these cognate VEGF receptors.

12.2 Pharmacodynamics

In the phase 3 studies anatomic measures of disease activity improved similarly in all treatment groups from baseline to week 52. Anatomic data were not used to influence treatment decisions.

12.3 Pharmacokinetics

EYLEA is administered intravitreally to exert local effects in the eye. In patients with wet AMD, following intravitreal administration of EYLEA, a fraction of the administered dose is expected to bind with endogenous VEGF in the eye to form an inactive aflibercept: VEGF complex. Once absorbed into the systemic circulation, aflibercept presents in the plasma as free aflibercept (unbound to VEGF) and a more predominant stable inactive form with circulating endogenous VEGF (i.e., aflibercept: VEGF complex).

Absorption/Distribution

Following intravitreal administration of 2 mg per eye of EYLEA to patients with wet AMD, the mean C_{max} of free aflibercept in the plasma was 0.02 mcg/mL (range: 0 to 0.054 mcg/mL) and was attained in 1 to 3 days. The free aflibercept plasma concentrations were undetectable two weeks post-dosing in all patients. Aflibercept did not accumulate in plasma when administered as repeated doses intravitreally every 4 weeks. It is estimated that after intravitreal administration of 2 mg to patients, the mean maximum plasma concentration of free aflibercept is more than 100 fold lower than the concentration of aflibercept required to half-maximally bind systemic VEGF.

The volume of distribution of free aflibercept following intravenous (I.V.) administration of aflibercept has been determined to be approximately 6L.

Metabolism/Elimination

Aflibercept is a therapeutic protein and no drug metabolism studies have been conducted. Aflibercept is expected to undergo elimination through both target-mediated disposition via binding to free endogenous VEGF and metabolism via proteolysis. The terminal elimination half-life ($t_{1/2}$) of free aflibercept in plasma was approximately 5 to 6 days after I.V. administration of doses of 2 to 4 mg/kg aflibercept.

Specific Populations

Renal Impairment

Pharmacokinetic analysis of a subgroup of patients (n=492) in one Phase 3 study, of which 43% had renal impairment (mild n=120, moderate n=74, and severe n=16), revealed no differences with respect to plasma concentrations of free aflibercept after intravitreal administration every 4 or 8 weeks. No dose adjustment based on renal impairment status is needed.

13 NONCLINICAL TOXICOLOGY

13.1 Carcinogenesis, Mutagenesis, Impairment of Fertility

No studies have been conducted on the mutagenic or carcinogenic potential of aflibercept. Effects on male and female fertility were assessed as part of a 6-month study in monkeys with intravenous administration of aflibercept at doses ranging from 3 to 30 mg/kg. Absent or irregular menses associated with alterations in female reproductive hormone levels and changes in sperm morphology and motility were observed at all dose levels. In addition, females showed decreased ovarian and uterine weight accompanied by compromised luteal development and reduction of maturing follicles. These changes correlated with uterine and vaginal atrophy. A No Observed Adverse Effect Level (NOAEL) was not identified. Based on C_{max} and AUC for free aflibercept observed at the lowest dose used of 3 mg/kg, the systemic exposures were approximately 4900 times and 1500 times higher, respectively, than the exposure observed in humans after an intravitreal dose of 2 mg. All changes were reversible.

13.2 Animal Toxicology and/or Pharmacology

Erosions and ulcerations of the respiratory epithelium in nasal turbinates in monkeys treated with aflibercept intravitreally were observed at intravitreal doses of 2 or 4 mg/eye. At the NOAEL of 0.5 mg/eye in monkeys, the systemic exposure was 42 times and 56 times higher based on C_{max} and AUC, respectively, than the exposure observed in humans after an intravitreal dose of 2 mg. Similar effects were not seen in clinical studies [see *Clinical Studies (14)*].

14 CLINICAL STUDIES

The safety and efficacy of EYLEA were assessed in two randomized, multi-center, double-masked, active-controlled studies in patients with wet AMD. A total of 2412 patients were treated and evaluable for efficacy (1817 with EYLEA) in the two studies (VIEW1 and VIEW2).

In each study, patients were randomly assigned in a 1:1:1:1 ratio to 1 of 4 dosing regimens: 1) EYLEA administered 2 mg every 8 weeks following 3 initial monthly doses (EYLEA 2Q8); 2) EYLEA administered 2 mg every 4 weeks (EYLEA 2Q4); 3) EYLEA 0.5 mg administered every 4 weeks (EYLEA 0.5Q4); and 4) ranibizumab administered 0.5 mg every 4 weeks (ranibizumab 0.5 mg Q4). Patient ages ranged from 49 to 99 years with a mean of 76 years.

In both studies, the primary efficacy endpoint was the proportion of patients who maintained vision, defined as losing fewer than 15 letters of visual acuity at week 52 compared to baseline. Data are available through week 52. Both EYLEA 2Q8 and EYLEA 2Q4 groups were shown to have efficacy that was clinically equivalent to the ranibizumab 0.5 mg Q4 group.

Detailed results from the analysis of the VIEW1 and VIEW2 studies are shown in Table 2 and Figure 9 below.

Table 2: Efficacy Outcomes at Week 52 (Full Analysis Set with LOCF) in VIEW1 and VIEW2 Studies

	VIEW1			VIEW2		
	EYLEA 2 mg Q8 weeks ^a	EYLEA 2 mg Q4 weeks	ranibizu- mab 0.5 mg Q4 weeks	EYLEA 2 mg Q8 weeks ^a	EYLEA 2 mg Q4 weeks	ranibizu- mab 0.5 mg Q4 weeks
Full Analysis Set	N=301	N=304	N=304	N=306	N=309	N=291
Efficacy Outcomes						
Proportion of patients who maintained visual acuity (%) (<15 letters of BCVA loss)	94%	95%	94%	95%	95%	95%
Difference ^b (%) (95.1% CI)	0.6 (-3.2, 4.4)	1.3 (-2.4, 5.0)		0.6 (-2.9, 4.0)	-0.3 (-4.0, 3.3)	
Mean change in BCVA as measured by ETDRS letter score from Baseline	7.9	10.9	8.1	8.9	7.6	9.4
Difference ^b in LS mean (95.1% CI)	0.3 (-2.0, 2.5)	3.2 (0.9, 5.4)		-0.9 (-3.1, 1.3)	-2.0 (-4.1, 0.2)	
Number of patients who gained at least 15 letters of vision from Baseline (%)	92 (31%)	114 (38%)	94 (31%)	96 (31%)	91 (29%)	99 (34%)
Difference ^b (%) (95.1% CI)	-0.4 (-7.7, 7.0)	6.6 (-1.0, 14.1)		-2.6 (-10.2, 4.9)	-4.6 (-12.1, 2.9)	

BCVA = Best Corrected Visual Acuity; CI = Confidence Interval; ETDRS = Early Treatment Diabetic Retinopathy Study; LOCF = Last Observation Carried Forward (baseline values are not carried forward); 95.1% confidence intervals were presented to adjust for safety assessment conducted during the study.

^a After treatment initiation with 3 monthly doses

^b EYLEA group minus the ranibizumab group

Figure 9: Mean Change in Visual Acuity from Baseline to Week 52 in VIEW1 and VIEW2 Studies

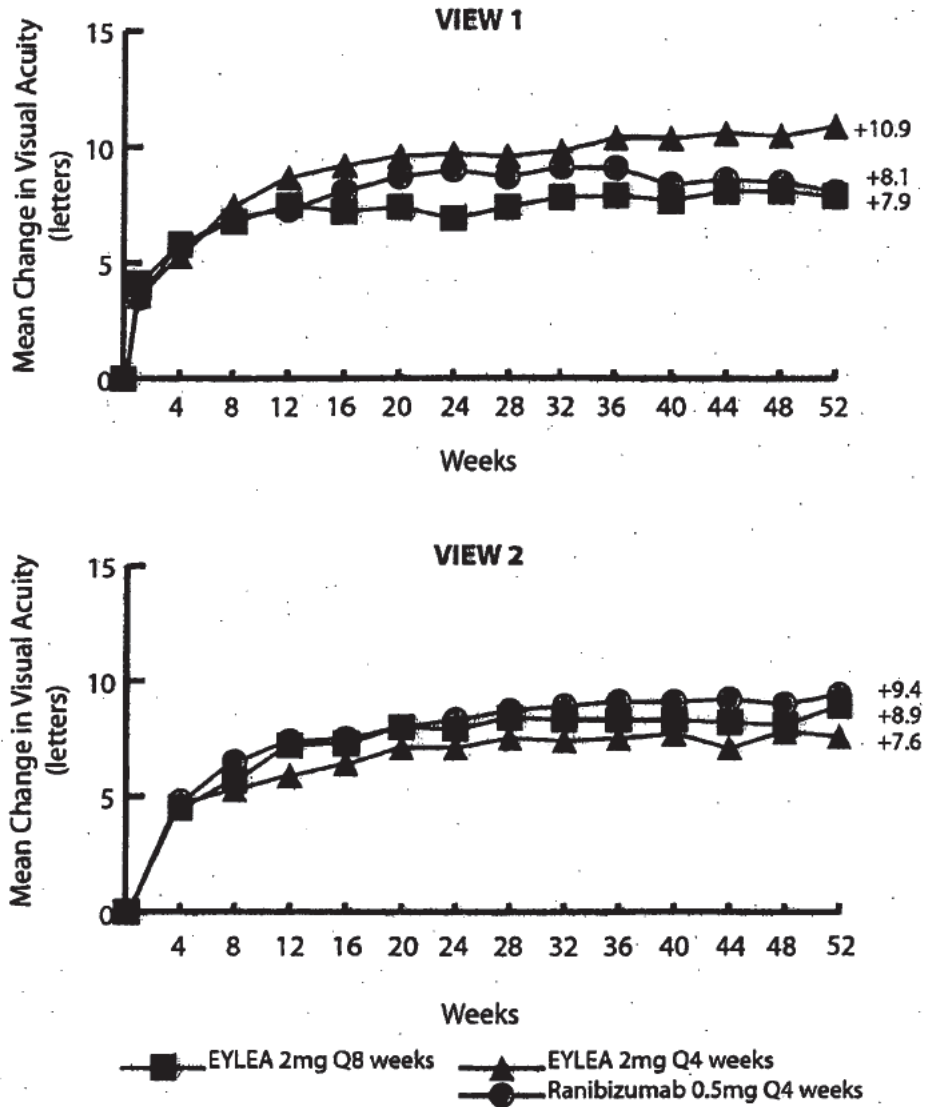

16 HOW SUPPLIED/STORAGE AND HANDLING

Each Vial is for single eye use only. EYLEA is supplied in the following presentation [see *Dosage and Administration (2.3) and (2.4)*].

NDC NUMBER	CARTON TYPE	CARTON CONTENTS
61755-005-02	Vial	one single-use, sterile, 3-mL, glass vial containing a 0.278 mL fill of 40 mg/mL EYLEA one 19-gauge x 1½-inch, 5-micron, filter needle for withdrawal of the vial contents one 30-gauge x ½-inch injection needle for intravitreal injection one 1-mL syringe for administration one package insert

Storage

EYLEA should be refrigerated at 2°C to 8°C (36°F to 46°F). Do Not Freeze. Do not use beyond the date stamped on the carton and container label. Protect from light. Store in the original carton until time of use.

17 PATIENT COUNSELING INFORMATION

Patients may experience temporary visual disturbances after an intravitreal injection with EYLEA and the associated eye examinations [see *Adverse Reactions (6)*]. Patients should be advised not to drive or use machinery until visual function has recovered sufficiently.

In the days following EYLEA administration, patients are at risk of developing endophthalmitis or retinal detachment. If the eye becomes red, sensitive to light, painful, or develops a change in vision, the patient should seek immediate care from an ophthalmologist [see *Warnings and Precautions (5.1)*].

REGENERON

Manufactured by:

Regeneron Pharmaceuticals, Inc.

777 Old Saw Mill River Road

Tarrytown, NY 10591-6707

U.S. License Number 1760

EYLEA™ is a trademark of Regeneron Pharmaceuticals, Inc.

© 2011, Regeneron Pharmaceuticals, Inc.

All rights reserved.

V1.0

Issue Date: November /2011

Initial U.S. Approval: 2011

Regeneron U.S. Patents 7,306,799; 7,531,173; 7,608,261; 7,070,959; 7,374,757; 7,374,758, and other pending patents

Carton Label

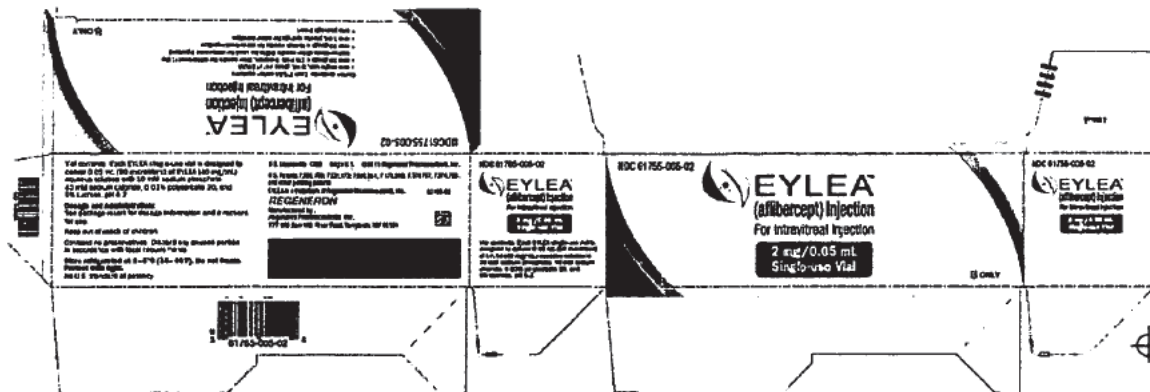

Vial Label

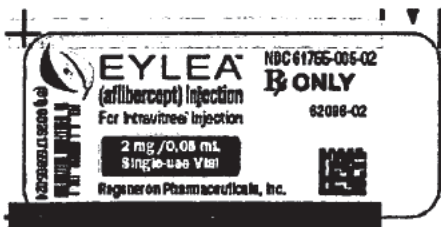

ATTACHMENT C

**Copy of EYLEA™ BLA Approval
Letter from the FDA**

Subject: Approval Letter for BLA 125387
Date: Friday, November 18, 2011 5:47 PM
From: Puglisi, Michael <Michael.Puglisi@fda.hhs.gov>
To: Laura Pologe <Laura.Pologe@regeneron.com>

Hi Laura,

Here it is. Congratulations. Please confirm receipt. The hard copy will be mailed on Monday.

Mike



Our STN: BL 125387/0

BLA APPROVAL
November 18, 2011

Regeneron Pharmaceuticals, Inc.
Attention: Laura Pologe, Ph.D.
Associate Director, Regulatory Affairs
777 Old Saw Mill River Road
Tarrytown, New York 10591-6707

Dear Dr. Pologe:

Please refer to your Biologics License Application (BLA) dated February 17, 2011, received February 18, 2011, submitted under section 351 of the Public Health Service Act for Eylea (aflibercept).

We acknowledge receipt of your amendments dated February 28, March 10, 18, and 24, April 1, 8, 11 (two), 13 (two), and 29, May 11, 16, 23, and 27, June 3, 7, 9, 16, 20, and 28, July 8, 18, and 19, August 1, 5, 10, 12, and 31, September 1, 7, 12, 20, and 26, October 7, 21, 24, and 27, and November 1, 9, 11, and 17, 2011.

We have approved your BLA for aflibercept effective this date. You are hereby authorized to introduce or deliver for introduction into interstate commerce, aflibercept under your existing Department of Health and Human Services U.S. License No. 1760. Aflibercept is indicated for treatment of neovascular (wet) age-related macular degeneration.

Under this license, you are approved to manufacture aflibercept drug substance intermediate, drug substance, and formulated bulk at (b)(4). The final formulated drug product will be manufactured at (b)(4). The final formulated drug product will be labeled and packaged at (b)(4). You may label your product with the proprietary name Eylea and market it in a (b)(4) single-use vial containing 0.278 mL of 40 mg/mL aflibercept, as part of a final packaged product containing the aflibercept single-use vial, a 19-gauge x 1½-inch 5-micron filter needle, a 30-gauge x ½-inch needle and a 1-mL plastic syringe.

The dating period for aflibercept shall be 15 months from the date of manufacture when stored at 2 - 8°C. The date of manufacture shall be defined as the (b)(4). The expiration date for the packaged product, (aflibercept single-use vials, syringe, needle and filter needle) shall be dependent on the shortest expiration date of any component. (b)(4)

Results of ongoing stability should be submitted to the annual report.

You are not currently required to submit samples of future lots of aflibercept to the Center for Drug Evaluation and Research (CDER) for release by the Director, CDER, under 21 CFR 610.2. We will continue to monitor compliance with 21 CFR 610.1, requiring completion of tests for conformity with standards applicable to each product prior to release of each lot.

Any changes in the manufacturing, testing, packaging, or labeling of aflibercept, or in the manufacturing facilities, will require the submission of information to your biologics license application for our review and written approval, consistent with 21 CFR 601.12.

We are approving this application for use as recommended in the enclosed agreed-upon labeling text.

CONTENT OF LABELING

As soon as possible, but no later than 14 days from the date of this letter, submit, via the FDA automated drug registration and listing system (eLIST), the content of labeling [21 601.14(b)] in structured product labeling (SPL) format, as described at <http://www.fda.gov/ForIndustry/DataStandards/StructuredProductLabeling/default.htm>, that is identical to the enclosed labeling (text for the package insert). Information on submitting SPL files using eLIST may be found in the guidance for industry titled "SPL Standard for Content of Labeling Technical Qs and As" at <http://www.fda.gov/downloads/Drugs/GuidanceComplianceRegulatoryInformation/Guidances/UCM072392.pdf>. For administrative purposes, please designate this submission "**Product Correspondence – Final SPL for approved BLA STN 125387.**"

The SPL will be accessible via publicly available labeling repositories.

CARTON AND IMMEDIATE CONTAINER LABELS

Submit final printed carton and container labels that are identical to the enclosed carton and immediate container labels submitted on November 17, 2011, as soon as they are available, but no more than 30 days after they are printed. Please submit these labels electronically according to the guidance for industry titled "Providing Regulatory Submissions in Electronic Format – Human Pharmaceutical Product Applications and Related Submissions Using the eCTD Specifications (June 2008)". Alternatively, you may submit 12 paper copies, with 6 of the copies individually mounted on heavy-weight paper or similar material. For administrative purposes, designate this submission "**Product Correspondence – Final Printed Carton and Container Labels for approved BLA STN 125387.**" Approval of this submission by FDA is not required before the labeling is used.

Marketing the product(s) with final printed labeling (FPL) that is not identical to the approved labeling text may render the product misbranded and an unapproved new drug.

REQUIRED PEDIATRIC ASSESSMENTS

Under the Pediatric Research Equity Act (PREA) (21 U.S.C. 355c), all applications for new active ingredients, new indications, new dosage forms, new dosing regimens, or new routes of administration are required to contain an assessment of the safety and effectiveness of the product for the claimed indication(s) in pediatric patients unless this requirement is waived, deferred, or inapplicable. We are waiving the pediatric study requirement for this application because the product treats a disease that does not exist in pediatric age groups.

POSTMARKETING REQUIREMENTS UNDER 505(o)

Section 505(o)(3) of the Federal Food, Drug, and Cosmetic Act (FDCA) authorizes FDA to require holders of approved drug and biological product applications to conduct postmarketing studies and clinical trials for certain purposes, if FDA makes certain findings required by the statute.

We have determined that an analysis of spontaneous postmarketing adverse events reported under subsection 505(k)(1) of the FDCA will not be sufficient to identify an unexpected serious risk of corneal endothelial cell decompensation following the intravitreal administration of Eylea (aflibercept).

Furthermore, the new pharmacovigilance system that FDA is required to establish under section 505(k)(3) of the FDCA will not be sufficient to assess this serious risk.

Finally, we have determined that only a clinical trial (rather than a nonclinical or observational study) will be sufficient to identify an unexpected serious risk of corneal endothelial cell decompensation following the intravitreal administration of Eylea (aflibercept).

Therefore, based on appropriate scientific data, FDA has determined that you are required to conduct the following:

1. Provide clinical information from a 1-year (minimum) clinical trial evaluating the adverse effects, if any, on the corneal endothelium following administration of aflibercept.

The timetable you submitted on October 24, 2011, states that you will conduct this trial according to the following schedule:

Final Protocol Submission:	March 2012
Trial Completion:	November 2015
Final Report Submission:	May 2016

Submit the protocol to your IND 12462, with a cross-reference letter to this BLA. Submit all final report(s) to your BLA. Prominently identify the submission with the following wording in

bold capital letters at the top of the first page of the submission, as appropriate: “**Required Postmarketing Protocol Under 505(o)**”, “**Required Postmarketing Final Report Under 505(o)**”, “**Required Postmarketing Correspondence Under 505(o)**”.

Section 505(o)(3)(E)(ii) of the FDCA requires you to report periodically on the status of any study or clinical trial required under this section. This section also requires you to periodically report to FDA on the status of any study or clinical trial otherwise undertaken to investigate a safety issue. Section 506B of the FDCA, as well as 21 CFR 601.70 requires you to report annually on the status of any postmarketing commitments or required studies or clinical trials.

FDA will consider the submission of your annual report under section 506B and 21 CFR 601.70 to satisfy the periodic reporting requirement under section 505(o)(3)(E)(ii) provided that you include the elements listed in 505(o) and 21 CFR 601.70. We remind you that to comply with 505(o), your annual report must also include a report on the status of any study or clinical trial otherwise undertaken to investigate a safety issue. Failure to submit an annual report for studies or clinical trials required under 505(o) on the date required will be considered a violation of FDCA section 505(o)(3)(E)(ii) and could result in enforcement action.

POSTMARKETING COMMITMENTS NOT SUBJECT TO THE REPORTING REQUIREMENTS UNDER SECTION 506B

We remind you of your postmarketing commitments:

2. To conduct three drug product hold time studies of the 40 mg/mL vial presentation filled at [REDACTED] ^{(b)(4)} site. Material will be held at commercial scale, and microbiological samples (total viable count, bacterial endotoxin) will be taken at the end of the hold times. The completed validation report will be submitted as a CBE-0 supplement.

The timetable you submitted on November 11, 2011, states that you will conduct this study according to the following schedule:

Final Report Submission: November 2012

3. To conduct three drug product hold time studies for the 40 mg/mL vial presentation filled at the [REDACTED] ^{(b)(4)} site. These studies will include t=0 and end of hold samples for product quality (pH, purity by size exclusion, purity by nrSDS-PAGE, charge variant distribution by IEF, isoaspartate, and potency of aflibercept) evaluation. The completed validation report will be provided as a CBE-0 supplement.

The timetable you submitted on November 11 2011, states that you will conduct this study according to the following schedule:

Final Report Submission: June 2012

4. To confirm (b)(4) by the aflibercept (b)(4) process. The (b)(4) study will be performed under protocol on three lots of drug substance produced at the commercial scale. (b)(4) will be measured with a validated analytical test method for determining (b)(4). The completed method validation and final reports will be submitted in the 2012 annual report by January 2013.

The timetable you submitted on November 11, 2011, states that you will conduct this study according to the following schedule:

Final Report Submission: January 2013

5. To re-evaluate the release and shelf-life specifications for aflibercept drug product after 30 commercial manufacturing runs to reflect increased manufacturing experience. The revisions to the quality control system, the corresponding data from the 30 commercial manufacturing runs, and the analysis and statistical plan used to evaluate the specifications and any changes to specifications will be provided in a PAS within 60 days after completion of the 30th lot manufactured using the commercial process or by December, 2014, whichever occurs first.

The timetable you submitted on November 11, 2011, states that you will conduct this study according to the following schedule:

Final Report Submission: December 2014

6. To re-evaluate the release and shelf-life specifications for aflibercept drug substance after 30 commercial manufacturing runs to reflect increased manufacturing experience. The revisions to the quality control system, the corresponding data from the 30 commercial manufacturing runs, and the analysis and statistical plan used to evaluate the specifications and any changes to specifications will be provided in a PAS by within 60 days after completion of the 30th lot manufactured using the commercial process or by June, 2013, whichever occurs first.

The timetable you submitted on November 11, 2011, states that you will conduct this study according to the following schedule:

Final Report Submission: June 2013

7. To re-evaluate the release and shelf-life specifications for aflibercept drug substance intermediate after 30 commercial manufacturing runs to reflect increased manufacturing experience. The revisions to the quality control system, the corresponding data from the 30 commercial manufacturing runs, and the analysis and statistical plan used to evaluate the specifications and any changes to specifications will be provided in a PAS within 60 days after completion of the 30th lot manufactured using the commercial process or by June, 2014, whichever occurs first.

The timetable you submitted on November 11, 2011, states that you will conduct this study according to the following schedule:

Final Report Submission: June 2014

8. To re-evaluate the release and shelf-life specifications for aflibercept formulated bulk after 30 commercial manufacturing runs to reflect increased manufacturing experience. The revisions to the quality control system, the corresponding data from the 30 commercial manufacturing runs, and the analysis and statistical plan used to evaluate the specifications and any changes to specifications will be provided in a PAS within 60 days after completion of the 30th lot manufactured using the commercial process or by June, 2013, whichever occurs first.

The timetable you submitted on November 11, 2011, states that you will conduct this study according to the following schedule:

Final Report Submission: June 2013

Submit clinical protocols to your IND 12462 for this product. Submit nonclinical and chemistry, manufacturing, and controls protocols and all final reports to this BLA. In addition, under 21 CFR 601.70 you should include a status summary of each commitment in your annual progress report of postmarketing studies and clinical trials to this BLA. The status summary should include expected summary completion and final report submission dates, any changes in plans since the last annual report, and, for clinical studies/trials, number of patients entered into each study/trial. All submissions, including supplements, relating to these postmarketing commitments should be prominently labeled "**Postmarketing Commitment Protocol**," "**Postmarketing Commitment Final Report**," or "**Postmarketing Commitment Correspondence**."

REPORTING REQUIREMENTS

You must submit adverse experience reports under the adverse experience reporting requirements for licensed biological products (21 CFR 600.80). You should submit postmarketing adverse experience reports to:

Food and Drug Administration
Center for Drug Evaluation and Research
Central Document Room
5901-B Ammendale Road
Beltsville, MD 20705-1266

Prominently identify all adverse experience reports as described in 21 CFR 600.80.

The MedWatch-to-Manufacturer Program provides manufacturers with copies of serious adverse event reports that are received directly by the FDA. New molecular entities and important new biologics qualify for inclusion for three years after approval. Your firm is eligible to receive

copies of reports for this product. To participate in the program, please see the enrollment instructions and program description details at <http://www.fda.gov/Safety/MedWatch/HowToReport/ucm166910.htm>.

You must submit distribution reports under the distribution reporting requirements for licensed biological products (21 CFR 600.81).

You must submit reports of biological product deviations under 21 CFR 600.14. You should promptly identify and investigate all manufacturing deviations, including those associated with processing, testing, packing, labeling, storage, holding and distribution. If the deviation involves a distributed product, may affect the safety, purity, or potency of the product, and meets the other criteria in the regulation, you must submit a report on Form FDA-3486 to:

Food and Drug Administration
Center for Drug Evaluation and Research
Division of Compliance Risk Management and Surveillance
5901-B Ammendale Road
Beltsville, MD 20705-1266

Biological product deviations, sent by courier or overnight mail, should be addressed to:

Food and Drug Administration
Center for Drug Evaluation and Research
Division of Compliance Risk Management and Surveillance
10903 New Hampshire Avenue, Bldg. 51, Room 4206
Silver Spring, MD 20903

PROMOTIONAL MATERIALS

You may request advisory comments on proposed introductory advertising and promotional labeling. To do so, submit, in triplicate, a cover letter requesting advisory comments, the proposed materials in draft or mock-up form with annotated references, and the package insert to:

Food and Drug Administration
Center for Drug Evaluation and Research
Division of Drug Marketing, Advertising, and Communications
5901-B Ammendale Road
Beltsville, MD 20705-1266

You must submit final promotional materials, and the package insert, at the time of initial dissemination or publication, accompanied by a Form FDA 2253. For instruction on completing the Form FDA 2253, see page 2 of the Form. For more information about submission of promotional materials to the Division of Drug Marketing, Advertising, and Communications (DDMAC), see <http://www.fda.gov/AboutFDA/CentersOffices/CDER/ucm090142.htm>.

All promotional claims must be consistent with and not contrary to approved labeling. You should not make a comparative promotional claim or claim of superiority over other products unless you have substantial evidence to support that claim.

POST-ACTION FEEDBACK MEETING

New molecular entities and new biologics qualify for a post-action feedback meeting. Such meetings are used to discuss the quality of the application and to evaluate the communication process during drug development and marketing application review. The purpose is to learn from successful aspects of the review process and to identify areas that could benefit from improvement. If you would like to have such a meeting with us, call the Regulatory Project Manager for this application.

If you have any questions, call Michael Puglisi, Regulatory Project Manager, at (301) 796-0791.

Sincerely,

/ Edward Cox, M.D., M.P.H./
Edward Cox, M.D., M.P.H.
Director
Office of Antimicrobial Products
Center for Drug Evaluation and Research

ENCLOSURES:

Content of Labeling
Carton and Container Labeling

ATTACHMENT D

Copy of U.S. Patent 7,374,758



US007374758B2

(12) **United States Patent**
Papadopoulos et al.

(10) **Patent No.:** **US 7,374,758 B2**
(45) **Date of Patent:** ***May 20, 2008**

(54) **MODIFIED CHIMERIC POLYPEPTIDES WITH IMPROVED PHARMACOKINETIC PROPERTIES AND METHODS OF USING THEREOF**

(75) **Inventors:** **Nicholas J. Papadopoulos,** Lagrangeville, NY (US); **Samuel Davis,** New York, NY (US); **George D. Yancopoulos,** Yorktown Heights, NY (US)

(73) **Assignee:** **Regeneron Pharmaceuticals, Inc.,** Tarrytown, NY (US)

(*) **Notice:** Subject to any disclaimer, the term of this patent is extended or adjusted under 35 U.S.C. 154(b) by 489 days.

This patent is subject to a terminal disclaimer.

(21) **Appl. No.:** **11/016,503**

(22) **Filed:** **Dec. 17, 2004**

(65) **Prior Publication Data**
US 2005/0245447 A1 Nov. 3, 2005

Related U.S. Application Data

(62) Division of application No. 10/009,852, filed as application No. PCT/US00/14142 on May 23, 2000, now Pat. No. 7,070,959.

(60) Provisional application No. 60/138,133, filed on Jun. 8, 1999.

(51) **Int. Cl.**
A61K 38/18 (2006.01)
C07K 14/71 (2006.01)
C12N 15/62 (2006.01)

(52) **U.S. Cl.** **424/134.1; 424/192.1; 514/2; 514/23; 530/350; 536/23.4**

(58) **Field of Classification Search** **None**
See application file for complete search history.

(56) **References Cited**

U.S. PATENT DOCUMENTS

5,712,380 A	1/1998	Kendall et al.	
6,011,003 A	1/2000	Charnock-Jones et al.	
2004/0265309 A1*	12/2004	Kandel et al.	424/145.1
2005/0175610 A1*	8/2005	Wiegand et al.	424/145.1
2005/0260203 A1*	11/2005	Wiegand et al.	424/145.1
2005/0281822 A1*	12/2005	Cedarbaum et al.	424/145.1
2005/0281831 A1*	12/2005	Davis-Smyth et al.	424/178.1
2006/0210566 A1*	9/2006	Holash et al.	424/145.1
2007/0037748 A1*	2/2007	Stahl et al.	514/12

FOREIGN PATENT DOCUMENTS

WO	WO97/44453	11/1997
WO	WO98/13071	4/1998
WO	WO99/03996	1/1999

OTHER PUBLICATIONS

Wells, J.A. (1990). Additivity of mutational effects in proteins. *Biochemistry*. 29(37):8509-8517.*

Ngo et al. (1994). Computational complexity, protein structure prediction, and the Levinthal paradox. In Merz and Le Grand (Eds.) *The Protein Folding Problem and Tertiary Structure Prediction*. Birkhauser:Boston, pp. 491-495.*

Herley et al. (1999). Characterization of the VEGF binding site on the Flt-1 receptor. *Biochemical and Biophysical Research Communications*. 262:731-738.*

Terman, B.I., et al. "Identification of a new endothelial cell growth factor receptor tyrosine kinase", *Oncogene* (1991) 6:1677-1683.

Terman, B.I., et al. "Identification of the KDR tyrosine kinase as a receptor for vascular endothelial cell growth factor", *Biochem Biophys Res Comm* (1992) 187(3):1579-1586.

Tsutsumi, Y., et al. "PEGylation of interleukin-6 effectively increases its thrombopoietic potency", *Thrombosis and Haemostasis* (1997) 77(1):168-173.

Dunca, R. and Spreafico, F., "Polymer Conjugates", *Drug Delivery Systems* (1994) 27(4):290-306.

Hileman, R.E., et al., "Glycosaminoglycan-protein interactions: definitions of consensus sites in glycosaminoglycan binding proteins", *BioEssays* (1998) 20:156-167.

de Vries, Carlie, et al., "The *fms*-like tyrosine kinase, a receptor for vascular endothelial growth factor", *Science* (1992) 225:989-991.

Sharifi, J., et al., "Improving monoclonal antibody pharmacokinetics via chemical modification", *Quart J Nucl Med* (1998) 42:242-249.

Jensen-Pippo, K.E., et al., "Enteral bioavailability of human granulocyte colony stimulating factor conjugated with poly(ethylene glycol)", (1996) *Pharm Res* 13(1):102-107.

Tanaka, K., et al., "Characterization of the extracellular domain in vascular endothelial growth factor receptor-1 (Flt-1 Tyrosine kinase)", (1997) *Jpn J Cancer Res* 88:867-876.

Yang, J.C., et al., "The use of polyethylene glycol-modified interleukin-2 (PEG-IL-2) in the treatment of patients with metastatic renal cell carcinoma and melanoma", (1995) *Cancer* 76(4): 687-694.

Davis-Smyth, T., et al., 1996, "The second immunoglobulin-like domain of the VEGF tyrosine kinase receptor Flt-1 determines ligand binding and may initiate a signal transduction cascade", *The EMBO Journal* 15(18):4919-4927.

* cited by examiner

Primary Examiner—Christine J Saoud

Assistant Examiner—Jon M Lockard

(74) *Attorney, Agent, or Firm*—Valeta Gregg, Esq.

(57) **ABSTRACT**

Modified chimeric polypeptides with improved pharmacokinetics are disclosed. Specifically, modified chimeric Flt1 receptor polypeptides that have been modified in such a way as to improve their pharmacokinetic profile are disclosed. Also disclosed are methods of making and using the modified polypeptides including but not limited to using the modified polypeptides to decrease or inhibit plasma leakage and/or vascular permeability in a mammal.

3 Claims, 55 Drawing Sheets

Fig.1.

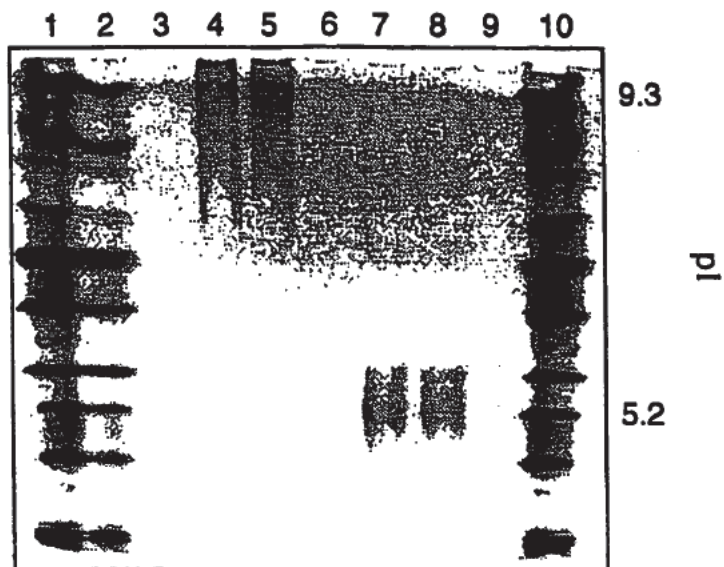

Fig.2.

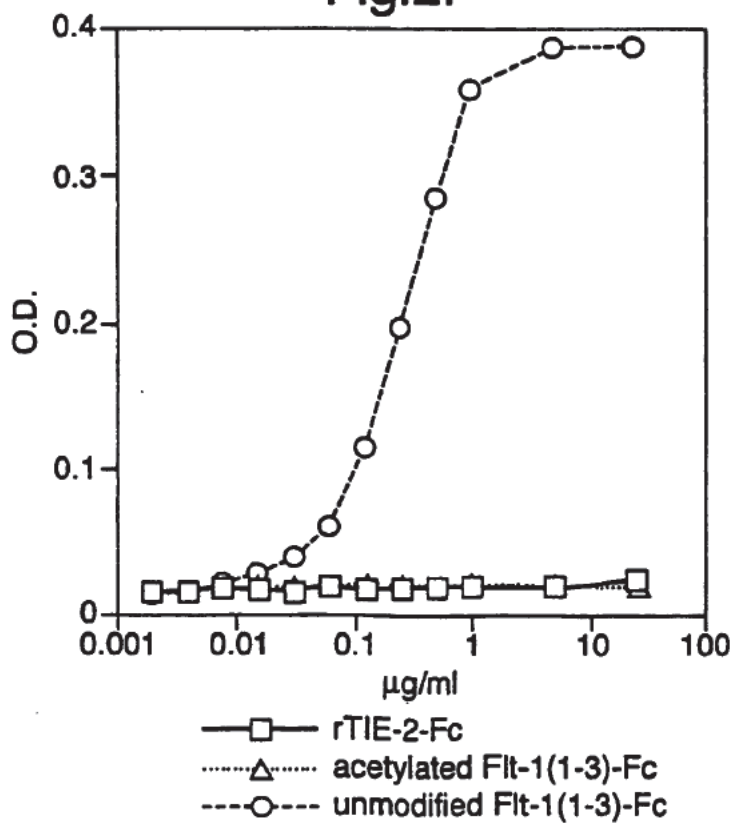
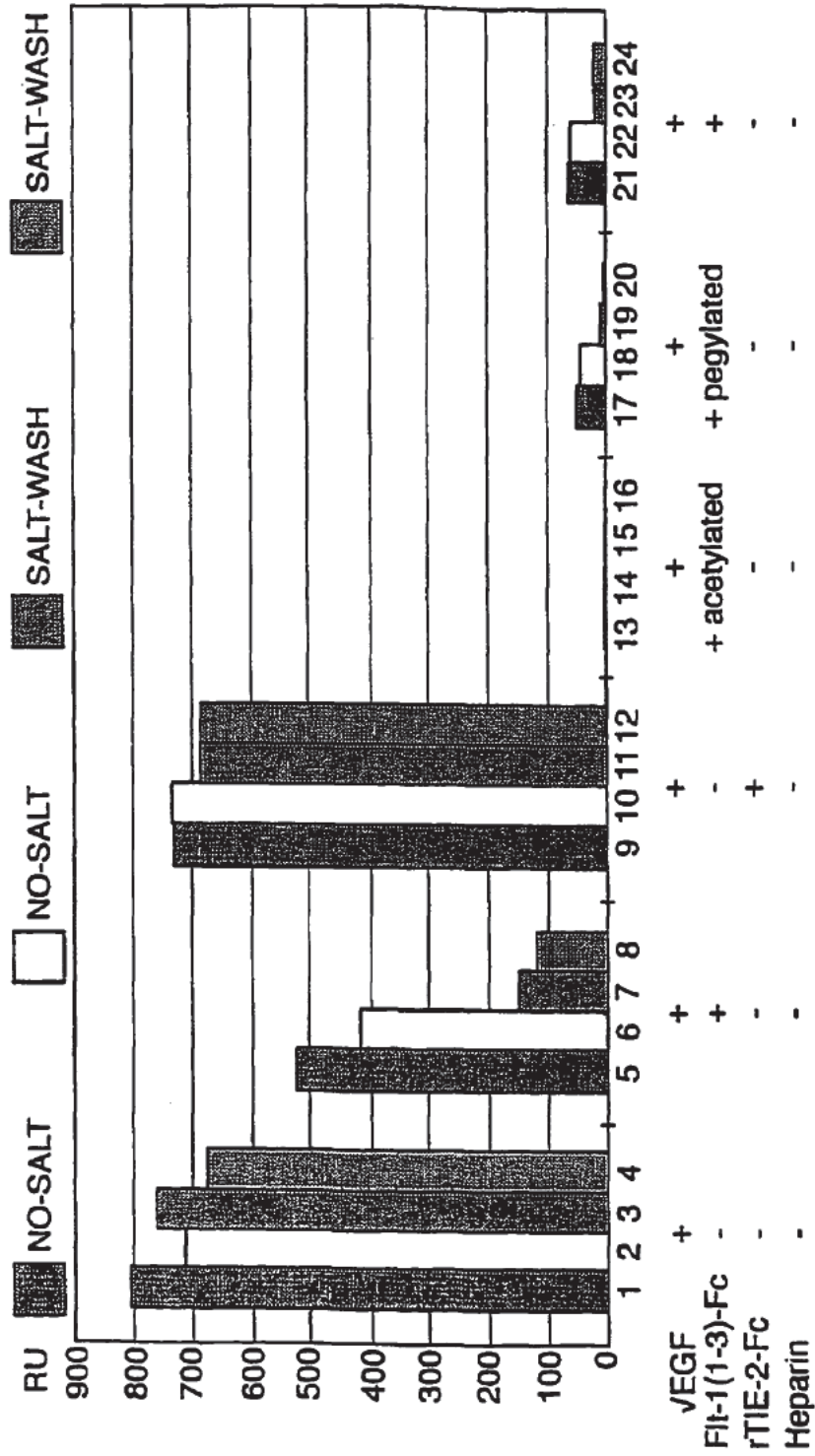

Fig.3.



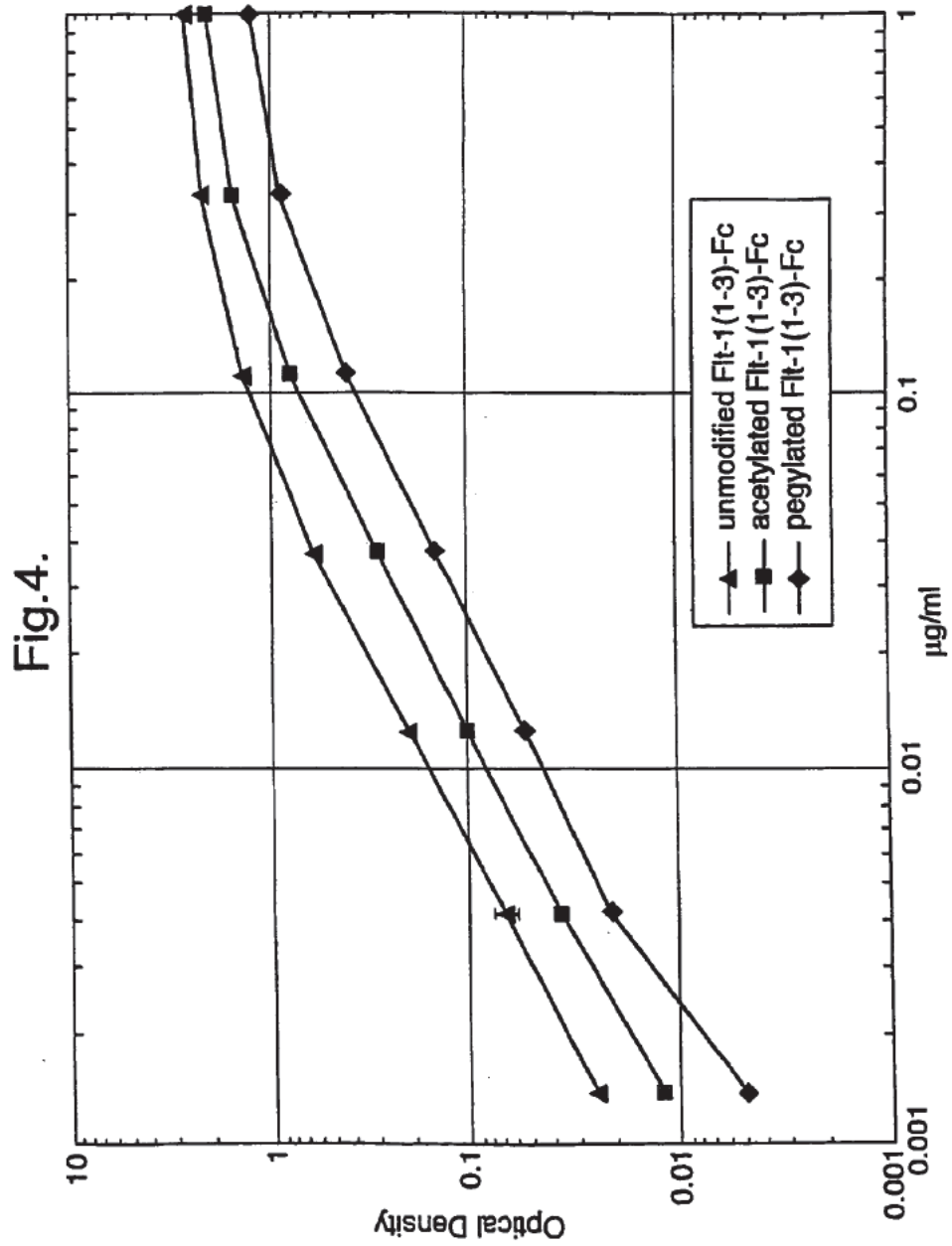

Fig.5.

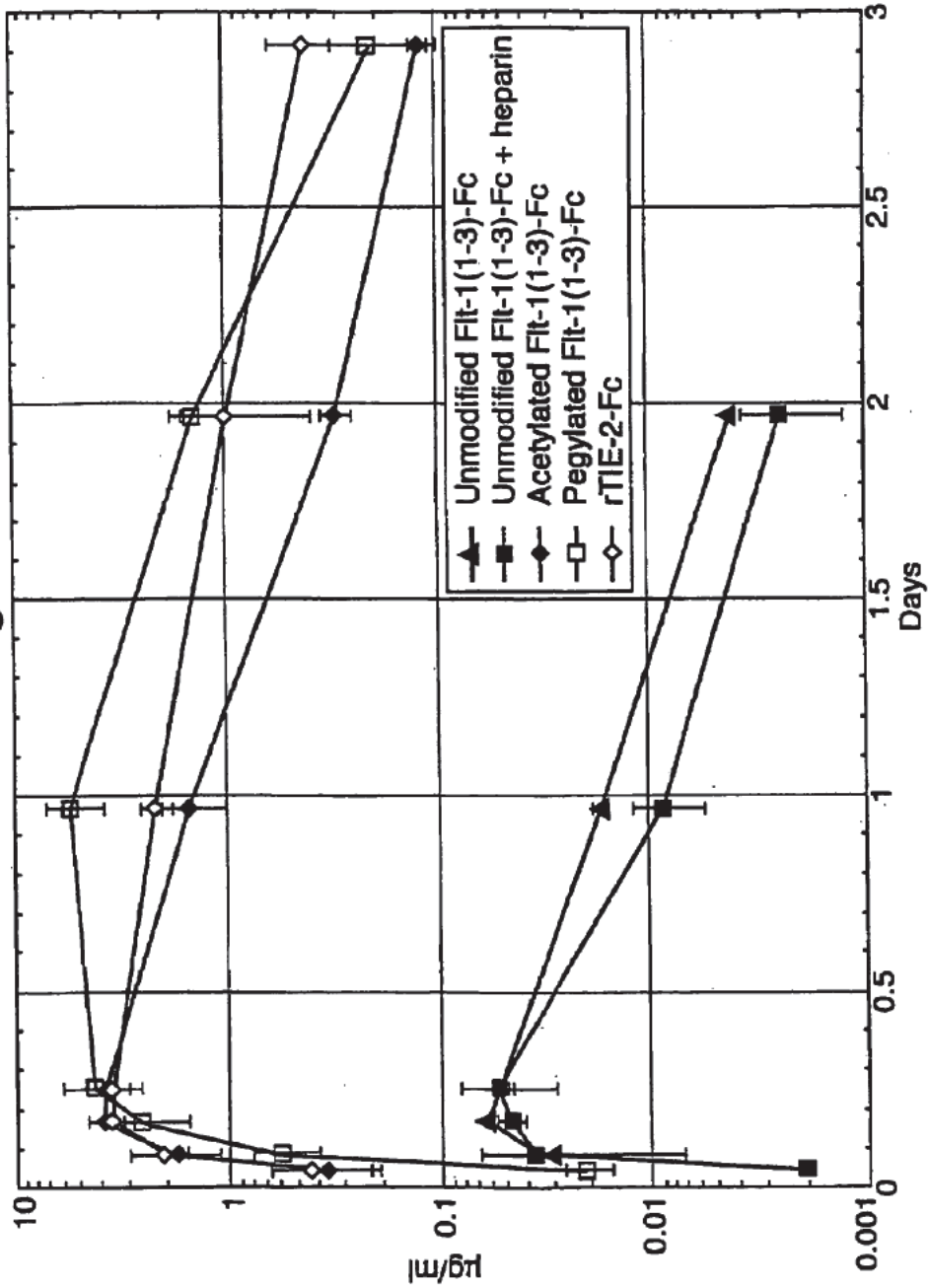

Fig.6A.

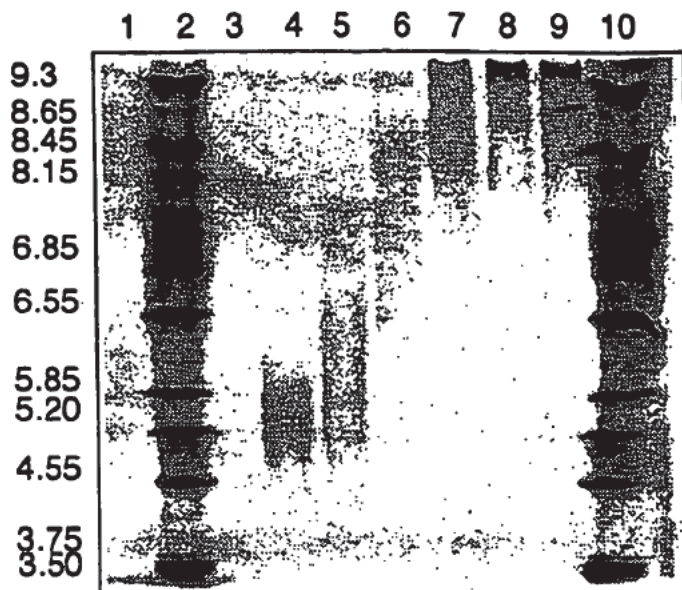

Fig.6B.

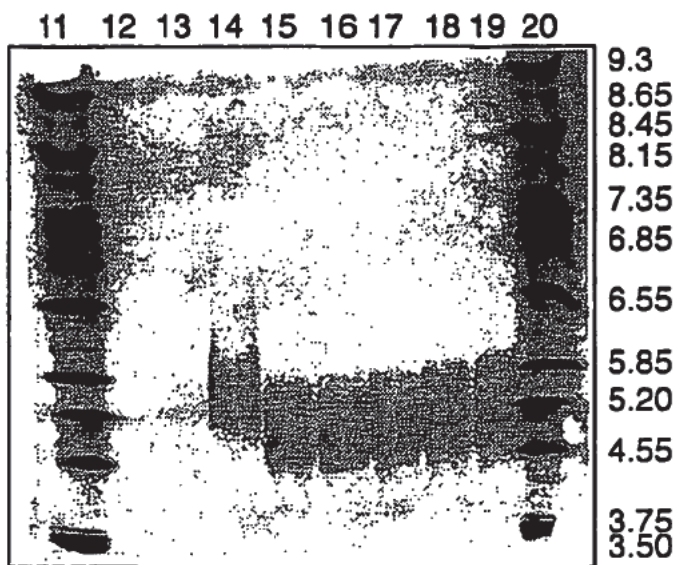
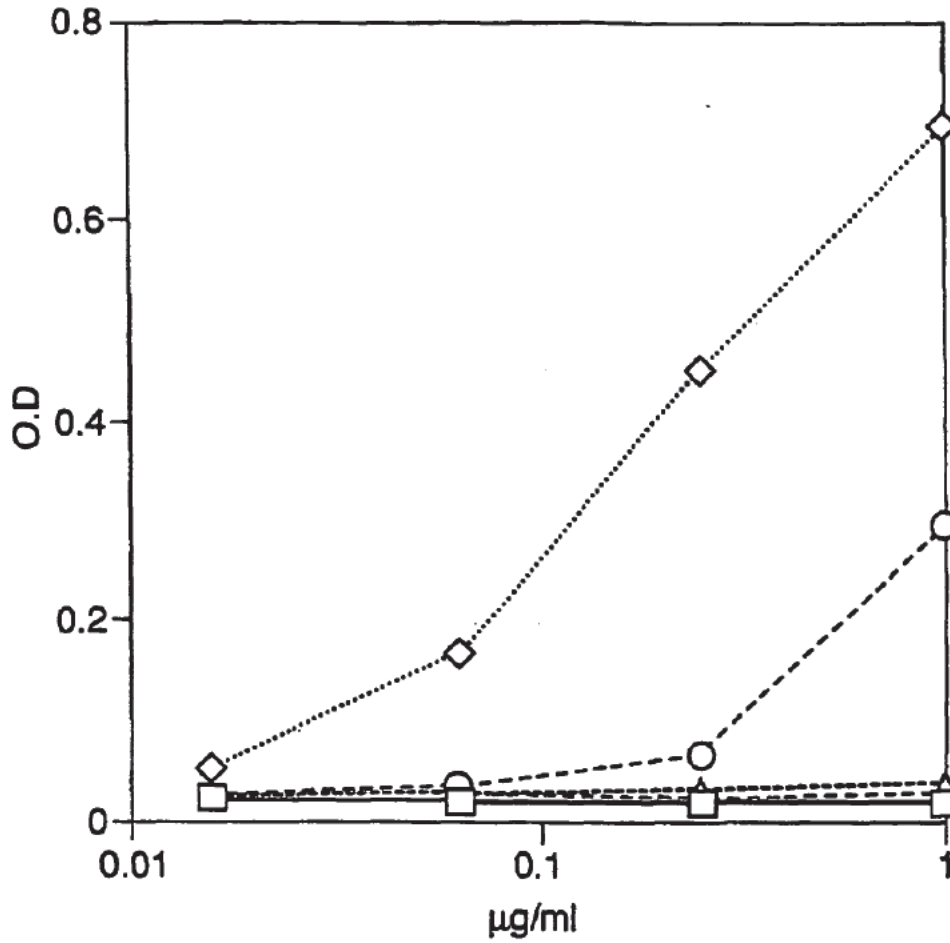
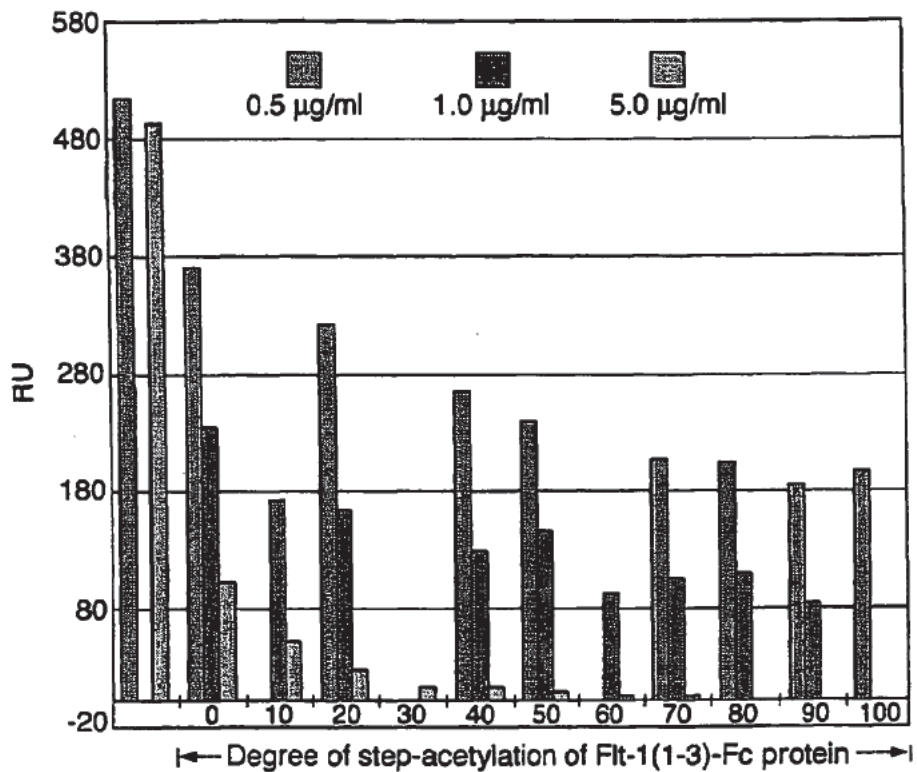

Fig.7.



- rTIE-2-Fc
-◇..... unmodified Flt-1(1-3)-Fc
- - -○- - - acetylated Flt-1(1-3)-Fc (10X)
- - -△- - - acetylated Flt-1(1-3)-Fc (20X)
- - -▣- - - acetylated Flt-1(1-3)-Fc (30X)

Fig.8.



	0	10	20	30	40	50	60	70	80	90	100
VEGF 0.2 µg/ml	+	+	+	+	+	+	+	+	+	+	+
Unmodified Flt-1(1-3) -Fc	-	+	-	-	-	-	-	-	-	-	-
Acetylated Flt-1(1-3) -Fc	-	-	+	+	+	+	+	+	+	+	+

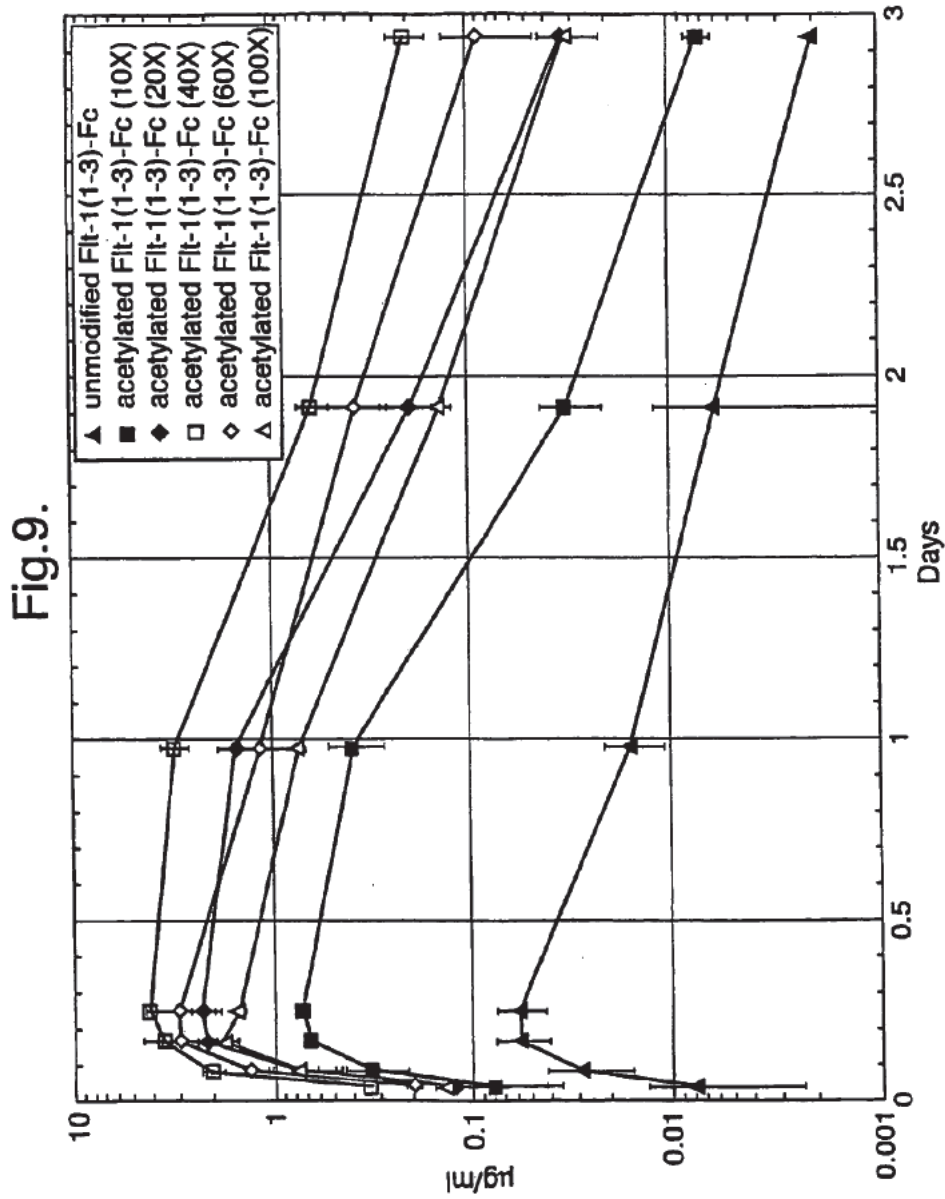

Fig.10A.

```

      10      20      30      40      50      60
      *      *      *      *      *      *
ATG GTC AGC TAC TGG GAC ACC GGG GTC CTG CTG TGC GCG CTG CTC AGC TGT CTG CTT CTC
TAC CAG TCG ATG ACC CTG TGG CCC CAG GAC GAC ACG CGC GAC GAG TCG ACA GAC GAA GAG
Met Val Ser Tyr Trp Asp Thr Gly Val Leu Leu Cys Ala Leu Leu Ser Cys Leu Leu Leu>

      70      80      90      100     110     120
      *      *      *      *      *      *
ACA GGA TCT AGT TCA GGT TCA AAA TTA AAA GAT CCT GAA CTG AGT TTA AAA GGC ACC CAG
TGT CCT AGA TCA AGT CCA AGT TTT AAT TTT CTA GGA CTT GAC TCA AAT TTT CCG TGG GTC
Thr Gly Ser Ser Ser Gly Ser Lys Leu Lys Asp Pro Glu Leu Ser Leu Lys Gly Thr Gln>

      130     140     150     160     170     180
      *      *      *      *      *      *
CAC ATC ATG CAA GCA GGC CAG ACA CTG CAT CTC CAA TGC AGG GGG GAA GCA GCC CRT AAA
GTG TAG TAC GTT CGT CCG GTC TGT GAC GTA GAG GTT ACG TCC CCC CTT CGT CCG GTA TTT
His Ile Met Gln Ala Gly Gln Thr Leu His Leu Gln Cys Arg Gly Glu Ala Ala His Lys>

      190     200     210     220     230     240
      *      *      *      *      *      *
TGG TCT TTG CCT GAA ATG GTG AGT AAG GAA AGC GAA AGG CTG AGC ATA ACT AAA TCT GCC
ACC AGA AAC GGA CTT TAC CAC TCA TTC CTT TCG CTT TCC GAC TCG TAT TGA TTT AGA CCG
Trp Ser Leu Pro Glu Met Val Ser Lys Glu Ser Glu Arg Leu Ser Ile Thr Lys Ser Ala>

      250     260     270     280     290     300
      *      *      *      *      *      *
TGT GGA AGA AAT GGC AAA CAA TTC TGC AGT ACT TTA ACC TTG AAC ACA GCT CAA GCA AAC
ACA CCT TCT TTA CCG TTT GTT AAG ACG TCA TGA AAT TGG AAC TTG TGT CGA GTT CGT TTG
Cys Gly Arg Asn Gly Lys Gln Phe Cys Ser Thr Leu Thr Leu Asn Thr Ala Gln Ala Asn>

      310     320     330     340     350     360
      *      *      *      *      *      *
CAC ACT GGC TTC TAC AGC TGC AAA TAT CTA GCT GTA CCT ACT TCA AAG AAG AAG GAA ACA
GTG TGA CCG AAG ATG TCG ACG TTT ATA GAT CGA CAT GGA TGA AGT TTC TTC TTC CTT TGT
His Thr Gly Phe Tyr Ser Cys Lys Tyr Leu Ala Val Pro Thr Ser Lys Lys Lys Glu Thr>

      370     380     390     400     410     420
      *      *      *      *      *      *
GAA TCT CCA ATC TAT AER TTT ATT AGT GAT ACA GGT AGA CCT TTC GTA GAG ATG TAC AGT
CTT AGA CGT TAG ATA TAT AAA TAA TCA CTA TGT CCA TCT GGA AAG CAT CTC TAC ATG TCA
Glu Ser Ala Ile Tyr Ile Phe Ile Ser Asp Thr Gly Arg Pro Phe Val Glu Met Tyr Ser>

      430     440     450     460     470     480
      *      *      *      *      *      *
GAA ATC CCC GAA ATT ATA CAC ATG ACT GAA GGA AGG GAG CTC GTC ATT CCC TGC CCG GTT
CTT TAG GGG CTT TAA TAT GTG TAC TGA CTT CCT TCC CTC GAG CAG TAA GGG ACG GCC CAA
Glu Ile Pro Glu Ile Ile His Met Thr Glu Gly Arg Glu Leu Val Ile Pro Cys Arg Val>

      490     500     510     520     530     540
      *      *      *      *      *      *
ACG TCA CCT AAC ATC ACT GTT ACT TTA AAA AAG TTT CCA CTT GAC ACT TTG ATC CCT GAT
TGC AGT GGA TTG TAG TGA CAA TGA AAT TTT TTC AAA GGT GRA CTG TGA AAC TAG GGA CTA
Thr Ser Pro Asn Ile Thr Val Thr Leu Lys Lys Phe Pro Leu Asp Thr Leu Ile Pro Asp>

```

Fig. 10B.

```

      550      560      570      580      590      600
      *      *      *      *      *      *
GGA AAA CGC ATA ATC TGG GAC AGT AGA AAG GGC TTC ATC ATA TCA AAT GCA ACG TAC AAA
CCT TTT GCG TAT TAG ACC CTG TCA TCT TTC CCG AAG TAG TAT AGT TTA CGT TGC ATG TTT
Gly Lys Arg Ile Ile Trp Asp Ser Arg Lys Gly Phe Ile Ile Ser Asn Ala Thr Tyr Lys>

      610      620      630      640      650      660
      *      *      *      *      *      *
GAA ATA GGG CTT CTG ACC TGT GAA GCA ACA GTC AAT GGG CAT TTG TAT AAG ACA AAC TAT
CTT TAT CCC GAA GAC TGG ACA CTT CGT TGT CAG TTA CCC GTA AAC ATA TTC TGT TTG ATA
Glu Ile Gly Leu Leu Thr Cys Glu Ala Thr Val Asn Gly His Leu Tyr Lys Thr Asn Tyr>

      670      680      690      700      710      720
      *      *      *      *      *      *
CTC ACA CAT CGA CAA ACC AAT ACA ATC ATA GAT GTC CAA ATA AGC ACA CCA CGC CCA GTC
GAG TGT GTA GCT GTT TGG TTA TGT TAG TAT CTA CAG GTT TAT TCG TGT GGT GCG GGT CAG
Leu Thr His Arg Gln Thr Asn Thr Ile Ile Asp Val Gln Ile Ser Thr Pro Arg Pro Val>

      730      740      750      760      770      780
      *      *      *      *      *      *
AAA TTA CTT AGA GGC CAT ACT CTT GTC CTC AAT TGT ACT GCT ACC ACT CCC TTG AAC ACG
TTT AAT GAA TCT CCG GTA TGA GAA CAG GAG TTA ACA TGA CGA TGG TGA GGG AAC TTG TGC
Lys Leu Leu Arg Gly His Thr Leu Val Leu Asn Cys Thr Ala Thr Thr Pro Leu Asn Thr>

      790      800      810      820      830      840
      *      *      *      *      *      *
AGA GTT CAA ATG ACC TGG AGT TAC CCT GAT GAA AAA AAT AAG AGA GCT TCC GTA AGG CGA
TCT CAA GTT TAC TGG ACC TCA ATG GGA CTA CTT TTT TTA TTC TCT CGA AGG CAT TCC GCT
Arg Val Gln Met Thr Trp Ser Tyr Pro Asp Glu Lys Asn Lys Arg Ala Ser Val Arg Arg>

      850      860      870      880      890      900
      *      *      *      *      *      *
CGA ATT GAC CAA AGC AAT TCC CAT GCC AAC ATA TTC TAC AGT GTT CTT ACT ATT GAC AAA
GCT TAA CTG GTT TCG TTA AGG GTA CCG TTG TAT AAG ATG TCA CAA GAA TGA TAA CTG TTT
Arg Ile Asp Gln Ser Asn Ser His Ala Asn Ile Phe Tyr Ser Val Leu Thr Ile Asp Lys>

      910      920      930      940      950      960
      *      *      *      *      *      *
ATG CAG AAC AAA GAC AAA GGA CTT TAT ACT TGT CGT GTA AGG AGT GGA CCA TCA TTC AAA
TAC GTC TTG TTT CTG TTT CCT GAA ATA TGA ACA GCA CAT TCC TCA CCT GGT AGT AAG TTT
Met Gln Asn Lys Asp Lys Gly Leu Tyr Thr Cys Arg Val Arg Ser Gly Pro Ser Phe Lys>

      970      980      990      1000      1010      1020
      *      *      *      *      *      *
TCT GTT AAC ACC TCA GTG CAT ATA TAT GAT AAA GCA GGC CCG GGC GAG CCG AAA TCT TGT
AGA CAA TTG TGG AGT CAC GTA TAT ATA CTA TTT CGT CCG GGC CCG CTC GGG TTT AGA ACA
Ser Val Asn Thr Ser Val His Ile Tyr Asp Lys Ala Gly Pro Gly Glu Pro Lys Ser Cys>

      1030      1040      1050      1060      1070      1080
      *      *      *      *      *      *
GAC AAA ACT CAC ACA TGC CCA CCG TGC CCA GCA CCT GAA CTC CTG GGG GGA CCG TCA GTC
CTG TTT TGA GTG TGT ACC GGT GGC ACG GGT CGT GGA CTT GAG GAC CCC CCT GGC AGT CAG
Asp Lys Thr His Thr Cys Pro Pro Cys Pro Ala Pro Glu Leu Leu Gly Gly Pro Ser Val>

```

Fig.10C.

```

      1090      1100      1110      1120      1130      1140
      *        *        *        *        *        *
TTC CTC TTC CCC CCA AAA CCC AAG GAC ACC CTC ATG ATC TCC CGG ACC CCT GAG GTC ACA
AAG GAG AAG GGG GGT TTT GGG TTC CTG TGG GAG TAC TAG AGG GCC TGG GGA CTC CAG TGT
Phe Leu Phe Pro Pro Lys Pro Lys Asp Thr Leu Met Ile Ser Arg Thr Pro Glu Val Thr>

      1150      1160      1170      1180      1190      1200
      *        *        *        *        *        *
TGC GTG GTG GTG GAC GTG AGC CAC GAA GAC CCT GAG GTC AAG TTC AAC TGG TAC GTG GAC
ACG CAC CAC CAC CTG CAC TCG GTG CTT CTG GGA CTC CAG TTC AAG TTG ACC ATG CAC CTG
Cys Val Val Val Asp Val Ser His Glu Asp Pro Glu Val Lys Phe Asn Trp Tyr Val Asp>

      1210      1220      1230      1240      1250      1260
      *        *        *        *        *        *
GGC GTG GAG GTG CAT AAT GCC AAG ACA AAG CCG CGG GAG GAG CAG TAC AAC AGC ACG TAC
COG CAC CTC CAC GGA TTA CCG TTC TGT TTC GGC GCC CTC CTC GTC ATG TTG TCG TGC ATG
Gly Val Glu Val His Asn Ala Lys Thr Lys Pro Arg Glu Glu Gln Tyr Asn Ser Thr Tyr>

      1270      1280      1290      1300      1310      1320
      *        *        *        *        *        *
CGT GTG GTC AGC GTC CTC ACC GTC CTG CAC CAG GAC TGG CTG AAT GGC AAG GAG TAC AAG
GCA CAC CAG TCG CAG GAG TGG CAG GAC GTG GTC CTG ACC GAC TTA CCG TTC CTC ATG TTC
Arg Val Val Ser Val Leu Thr Val Leu His Gln Asp Trp Leu Asn Gly Lys Glu Tyr Lys>

      1330      1340      1350      1360      1370      1380
      *        *        *        *        *        *
TGC AAG GTC TCC AAC AAA GCC CTC CCA GCC CCC ATC GAG AAA ACC ATC TCC AAA GCC AAA
ACG TTC CAG AGG TTG TTT CCG GAG GGT CCG GGG TAG CTC TTT TGG TAG AGG TTT CCG TTT
Cys Lys Val Ser Asn Lys Ala Leu Pro Ala Pro Ile Glu Lys Thr Ile Ser Lys Ala Lys>

      1390      1400      1410      1420      1430      1440
      *        *        *        *        *        *
GGG CAG CCC CGA GAA CCA CAG GTG TAC ACC CTG CCC CCA TCC CCG GAT GAG CTG ACC AAG
CCC GTC GGG GCT CTT GGT GTC CAC ATG TGG GAC GGG GGT AGG GCC CTA CTC GAC TGG TTC
Gly Gln Pro Arg Glu Pro Gln Val Tyr Thr Leu Pro Pro Ser Arg Asp Glu Leu Thr Lys>

      1450      1460      1470      1480      1490      1500
      *        *        *        *        *        *
AAC CAG GTC AGC CTG ACC TGC CTG GTC AAA GGC TTC TAT CCC AGC GAC ATC GGC GTG GAG
TTG GTC CAG TCG GAC TGG ACG GAC CAG TTT CCG AAG ATA GGG TCG CTG TAG CCG CAC CTC
Asn Gln Val Ser Leu Thr Cys Leu Val Lys Gly Phe Tyr Pro Ser Asp Ile Ala Val Glu>

      1510      1520      1530      1540      1550      1560
      *        *        *        *        *        *
TGG GAG AGC AAT GGG CAG CCG GAG AAC AAC TAC AAG ACC ACG CCT CCC GTG CTG GAC TCC
ACC CTC TCG TTA CCC GTC GGC CTC TTG TTG ATG TTC TGG TGC GGA GGG CAC GAC CTG AGG
Trp Glu Ser Asn Gly Gln Pro Glu Asn Asn Tyr Lys Thr Thr Pro Pro Val Leu Asp Ser>

      1570      1580      1590      1600      1610      1620
      *        *        *        *        *        *
GAC GGC TCC TTC TTC CTC TAC AGC AAG CTC ACC GTG GAC AAG AGC AGG TGG CAG CAG GGG
CTG CCG AGG AAG AAG GAG ATG TCG TTC GAG TGG CAC CTG TTC TCG TCC ACC GTC GTC CCC
Asp Gly Ser Phe Phe Leu Tyr Ser Lys Leu Thr Val Asp Lys Ser Arg Trp Gln Gln Gly>

```

Fig.10D.

```
          1630          1640          1650          1660          1670          1680
          *            *            *            *            *            *
AAC GTC TTC TCA TGC TCC GTG ATG CAT GAG GCT CTG CAC AAC CAC TAC ACG CAG AAG AGC
TTG CAG AAG AGT ACG AGG CAC TAC GTA CTC CGA GAC GTG TIG GTG ATG TGC GTC TTC TCG
Asn Val Phe Ser Cys Ser Val Met His Glu Ala Leu His Asn His Tyr Thr Gln Lys Ser>

          1690          1700
          *            *
CTC TCC CTG TCT CCG GGT AAA TGA
GAG AGG GAC AGA GGC CCA TTT ACT
Leu Ser Leu Ser Pro Gly Lys ***>
```

Fig. 11.

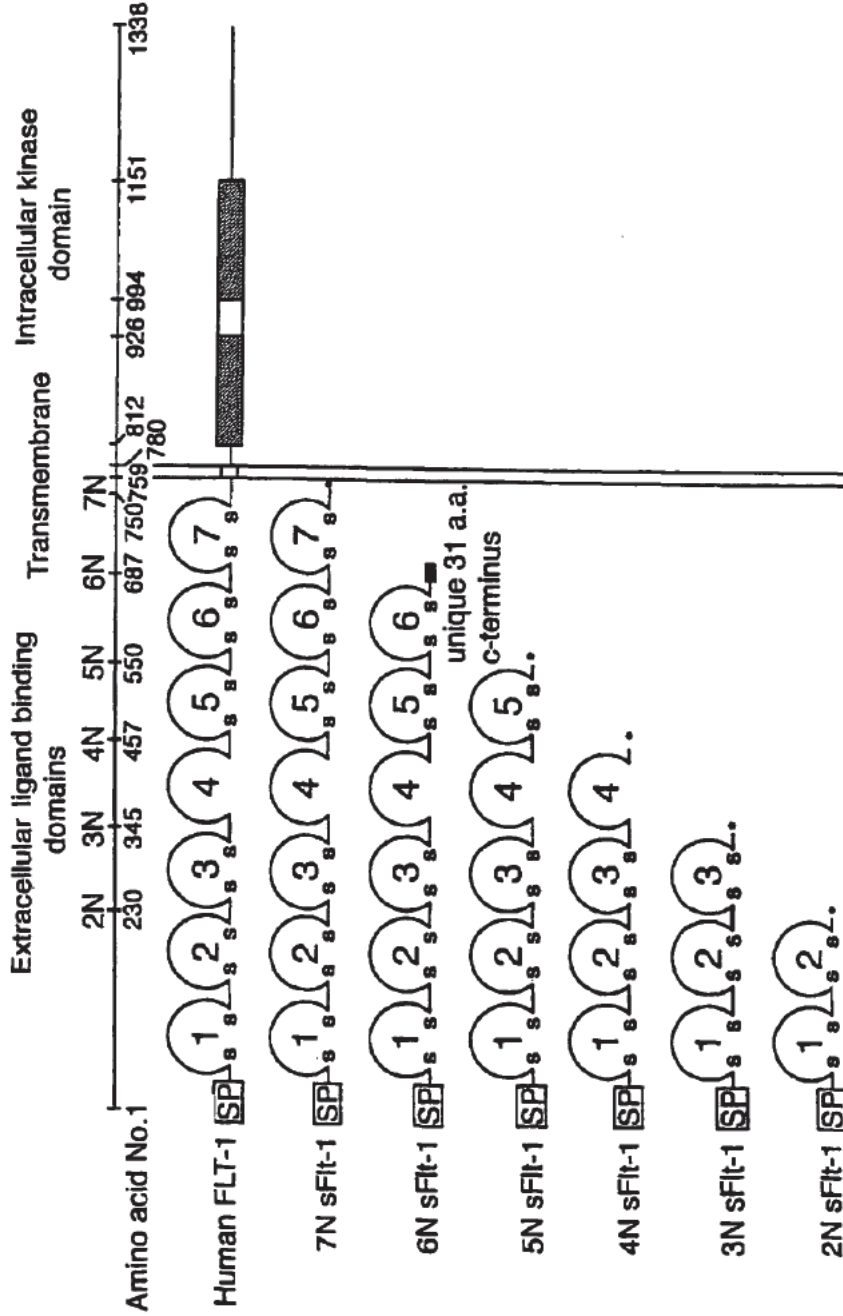

Fig.12A.

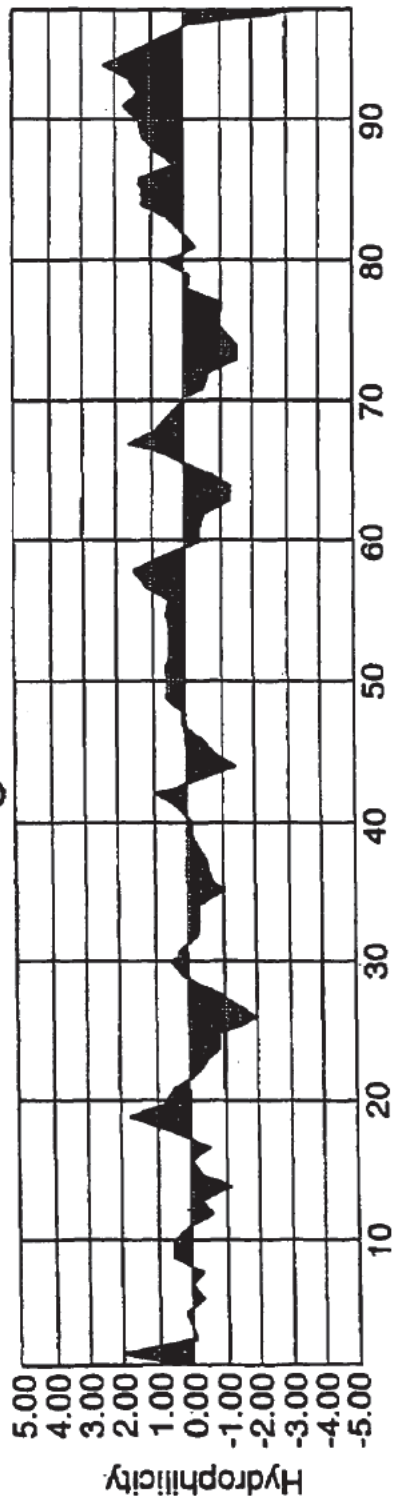

Fig.12B.

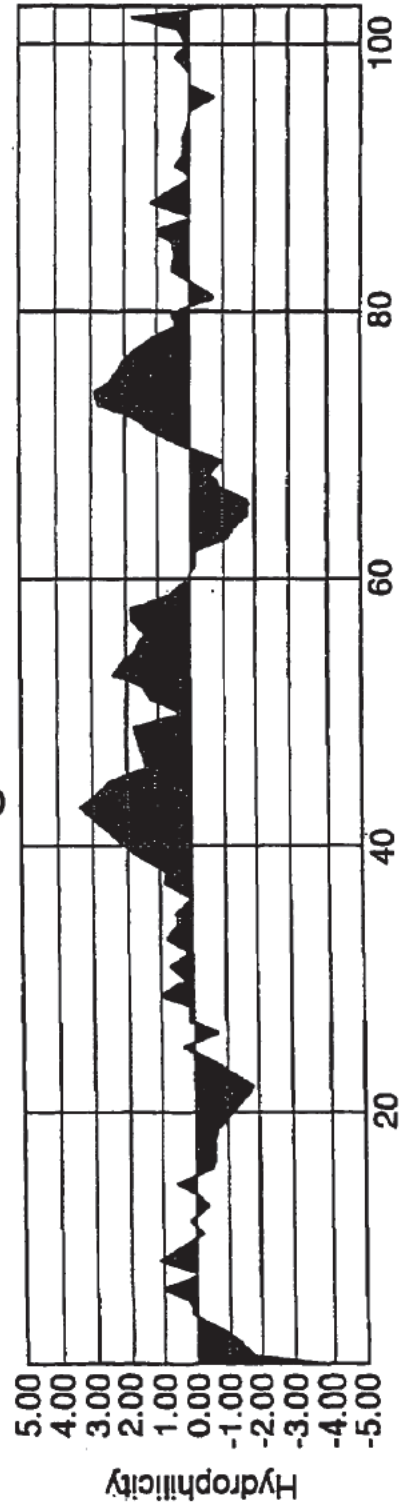

Fig. 13A.

```

      10      20      30      40      50      60
      *      *      *      *      *      *
ATG GTC AGC TAC TGG GAC ACC GGG GTC CTG CTG TGC GCG CTG CTC AGC TGT CTG CTT CTC
TAC CAG TCG ATG ACC CTG TGG CCC CAG GAC GAC ACG CGC GAC GAG TCG ACA GAC GAA GAG
Met Val Ser Tyr Trp Asp Thr Gly Val Leu Leu Cys Ala Leu Leu Ser Cys Leu Leu Leu>

      70      80      90      100     110     120
      *      *      *      *      *      *
ACA GGA TCT AGT TCA GGT TCA AAA TTA AAA GAT CCT GAA CTG AGT TTA AAA GGC ACC CAG
TGT CCT AGA TCA AGT CCA AGT TTT AAT TTT CTA GGA CTT GAC TCA AAT TTT CCG TGG GTC
Thr Gly Ser Ser Ser Gly Ser Lys Leu Lys Asp Pro Glu Leu Ser Leu Lys Gly Thr Gln>

      130     140     150     160     170     180
      *      *      *      *      *      *
CAC ATC ATG CAA GCA GGC CAG ACA CTG CAT CTC CAA TGC AGG GGG GAA GCA GCC CAT AAA
GAG TAG TAC GGT CTT CCG GTC TGT GAC GTA GAG GTT ACG TCC CCC CTT CGT CCG GTA TTT
His Ile Met Gln Ala Gly Gln Thr Leu His Leu Gln Cys Arg Gly Glu Ala Ala His Lys>

      190     200     210     220     230     240
      *      *      *      *      *      *
TGG TCT TTG CCT GAA ATG GTG AGT AAG GAA AGC GAA AGG CTG AGC ATA ACT AAA TCT GCC
ACC AGA AAC GGA CTT TAC CAC TCA TTC CTT TCG CTT TCC GAC TCG TAT TGA TTT AGA CCG
Trp Ser Leu Pro Glu Met Val Ser Lys Glu Ser Glu Arg Leu Ser Ile Thr Lys Ser Ala>

      250     260     270     280     290     300
      *      *      *      *      *      *
TGT GGA AGA AAT GGC AAA CAA TTC TGC AGT ACT TTA ACC TTG AAC ACA GCT CAA GCA AAC
ACA OCT TCT TTA CCG TTT GTT AAG ACG TCA TGA AAT TGG AAC TTG TGT CGA GTT CGT TTG
Cys Gly Arg Asn Gly Lys Gln Phe Cys Ser Thr Leu Thr Leu Asn Thr Ala Gln Ala Asn>

      310     320     330     340     350     360
      *      *      *      *      *      *
CAC ACT GGC TTC TAC AGC TGC AAA TAT CTA GCT GTA OCT ACT TCA AAG AAG AAG GAA ACA
GTG TGA CCG AAG ATG TCG ACG TTT ATA GAT CGA CAT GGA TGA AGT TTC TTC TTC CTT TGT
His Thr Gly Phe Tyr Ser Cys Lys Tyr Leu Ala Val Pro Thr Ser Lys Lys Lys Glu Thr>

      370     380     390     400     410     420
      *      *      *      *      *      *
GAA TCT GCA ATC TAT ATA TTT ATT AGT GAT ACA GGT AGA CCT TTC GTA GAG ATG TAC AGT
CTT AGA CGT TAG ATA TAT AAA TAA TCA CTA TGT OCA TCT GGA AAG CAT CTC TAC ATG TCA
Glu Ser Ala Ile Tyr Ile Phe Ile Ser Asp Thr Gly Arg Pro Phe Val Glu Met Tyr Ser>

      430     440     450     460     470     480
      *      *      *      *      *      *
GAA ATC CCC GAA ATT ATA CAC ATG ACT GAA GGA AGG GAG CTC GTC AIT CCC TGC OGG GTT
CTT TAG GGG CTT TAA TAT GTG TAC TGA CTT OCT TCC CTC GAG CAG TAA GGG ACG GCC CAA
Glu Ile Pro Glu Ile Ile His Met Thr Glu Gly Arg Glu Leu Val Ile Pro Cys Arg Val>

      490     500     510     520     530     540
      *      *      *      *      *      *
ACG TCA CCT AAC ATC ACT GTT ACT TTA AAA AAG TTT OCA CTT GAC ACT TTG ATC CCT GAT
TGC AGT GGA TTG TAG TGA CAA TGA AAT TTT TTC AAA GGT GAA CTG TGA AAC TAG GGA CTA
Thr Ser Pro Asn Ile Thr Val Thr Leu Lys Lys Phe Pro Leu Asp Thr Leu Ile Pro Asp>

```

Fig.13B.

```

      550      560      570      580      590      600
      *      *      *      *      *      *
GGA AAA CGC ATA ATC TGG GAC AGT AGA AAG GGC TTC ATC ATA TCA AAT GCA ACG TAC AAA
CCT TTT CCG TAT TAG ACC CTG TCA TCT TTC CCG AAG TGG TAT AGT TTA CGT TGC ATG TTT
Gly Lys Arg Ile Ile Trp Asp Ser Arg Lys Gly Phe Ile Ile Ser Asn Ala Thr Tyr Lys>

      610      620      630      640      650      660
      *      *      *      *      *      *
GAA ATA GGG CTT CTG ACC TGT GAA GCA ACA GTC AAT GGG CAT TTG TAT AAG ACA AAC TAT
CTT TAT CCC GAA GAC TGG ACA CTT CGT TGT CAG TTA CCC GTA AAC ATA TTC TGT TTG ATA
Glu Ile Gly Leu Leu Thr Cys Glu Ala Thr Val Asn Gly His Leu Tyr Lys Thr Asn Tyr>

      670      680      690      700      710      720
      *      *      *      *      *      *
CTC ACA CAT CGA CAA ACC AAT ACA ATC ATA GAT GTC CAA ATA AGC ACA CCA CGC CCA GTC
GAG TGT GTA GCT GTT TGG TTA TGT TAG TAT CTA CAG GTT TAT TCG TGT GGT GCG GGT CAG
Leu Thr His Arg Gln Thr Asn Thr Ile Ile Asp Val Gln Ile Ser Thr Pro Arg Pro Val>

      730      740      750      760      770      780
      *      *      *      *      *      *
AAA TTA CTT AGA GGC CAT ACT CTT GTC CTC AAT TGT ACT GCT ACC ACT CCC TTG AAC ACG
TTT AAT GAA TCT CCG GTA TGA GAA CAG GAG TTA ACA TGA CGA TGG TGA GGG AAC TTG TGC
Lys Leu Leu Arg Gly His Thr Leu Val Leu Asn Cys Thr Ala Thr Thr Pro Leu Asn Thr>

      790      800      810      820      830      840
      *      *      *      *      *      *
AGA GTT CAA ATG ACC TGG AGT TAC CCT GAT GAA ATT GAC CAA AGC AAT TCC CAT GCC AAC
TCT CAA GTT TAC TGG ACC TCA ATG GGA CTA CTT TAA CTG GTT TCG TTA AGG GTA CCG TTG
Arg Val Gln Met Thr Trp Ser Tyr Pro Asp Glu Ile Asp Gln Ser Asn Ser His Ala Asn>

      850      860      870      880      890      900
      *      *      *      *      *      *
ATA TTC TAC AGT GTT CTT ACT ATT GAC AAA ATG CAG AAC AAA GAC AAA GGA CTT TAT ACT
TAT AAG ATG TCA CAA GAA TGA TAA CTG TTT TAC GTC TTG TTT CTG TTT CCT GAA ATA TGA
Ile Phe Tyr Ser Val Leu Thr Ile Asp Lys Met Gln Asn Lys Asp Lys Gly Leu Tyr Thr>

      910      920      930      940      950      960
      *      *      *      *      *      *
TGT CGT GTA ASG AGT GGA CCA TCA TTC AAA TCT GTT AAC ACC TCA GTG CAT ATA TAT GAT
ACA GCA CAT TCC TCA CCT GGT AGT AAG TTT AGA CAA TTG TGG AGT CAC GTA TAT ATA CTA
Cys Arg Val Arg Ser Gly Pro Ser Phe Lys Ser Val Asn Thr Ser Val His Ile Tyr Asp>

      970      980      990      1000      1010      1020
      *      *      *      *      *      *
AAA GCA GGC CCG GGC GAG CCC AAA TCT TGT GAC AAA ACT CAC ACA TGC CCA CCG TGC CCA
TTT CCT CCG GGC CCG CTC GGG TTT AGA ACA CTG TTT TGA GTG TGT ACG GGT GGC ACG GGT
Lys Ala Gly Pro Gly Glu Pro Lys Ser Cys Asp Lys Thr His Thr Cys Pro Pro Cys Pro>

      1030      1040      1050      1060      1070      1080
      *      *      *      *      *      *
GCA CCT GAA CTC CTG GGG GGA CCG TCA GTC TTC CTC TTC CCC CCA AAA CCC AAG GAC ACC
CGT GCA CTT GAG GAC CCC CCT GGC AGT CAG AAG GAG AAG GGG GGT TTT GGG TTC CTG TGG
Ala Pro Glu Leu Leu Gly Gly Pro Ser Val Phe Leu Phe Pro Pro Lys Pro Lys Asp Thr>

```

Fig.13C.

```

      1090      1100      1110      1120      1130      1140
      *          *          *          *          *          *
CTC ATG ATC TCC CGG ACC OCT GAG GTC ACA TGC GTG GTG GTG GAC GTG AGC CAC GAA GAC
GAG TAC TAG AGG GCC TGG GGA CTC CAG TGT ACG CAC CAC CAC CTG CAC TCG GTG CTT CTG
Leu Met Ile Ser Arg Thr Pro Glu Val Thr Cys Val Val Val Asp Val Ser His Glu Asp>

      1150      1160      1170      1180      1190      1200
      *          *          *          *          *          *
CCT GAG GTC AAG TTC AAC TGG TAC GTG GAC GGC GTG GAG GTG CAT AAT GCC AAG ACA AAG
GGA CTC CAG TTC AAG TTG ACC ATG CAC CTG CCG CAC CTC CAC GTA TTA CCG TTC TGT TTC
Pro Glu Val Lys Phe Asn Trp Tyr Val Asp Gly Val Glu Val His Asn Ala Lys Thr Lys>

      1210      1220      1230      1240      1250      1260
      *          *          *          *          *          *
CCG CGG GAG GAG CAG TAC AAC AGC ACG TAC CGT GTG GTC AGC GTC CTC ACC GTC CTG CAC
GGC GCC CTC CTC GTC ATG TTG TCG TGC ATG GCA CAC CAG TCG CAG GAG TGG CAG GAC GTG
Pro Arg Glu Glu Gln Tyr Asn Ser Thr Tyr Arg Val Val Ser Val Leu Thr Val Leu His>

      1270      1280      1290      1300      1310      1320
      *          *          *          *          *          *
CAG GAC TGG CTG AAT GGC AAG GAG TAC AAG TGC AAG GTC TCC AAC AAA GCC CTC CCA GCC
GTC CTG ACC GAC TTA CCG TTC CTC ATG TTC ACG TTC CAG AGG TTG TTT CCG GAG GGT CCG
Gln Asp Trp Leu Asn Gly Lys Glu Tyr Lys Cys Lys Val Ser Asn Lys Ala Leu Pro Ala>

      1330      1340      1350      1360      1370      1380
      *          *          *          *          *          *
CCC ATC GAG AAA ACC ATC TCC AAA GCC AAA GGG CAG CCC CGA GAA CCA CAG GTG TAC ACC
GGG TAG CTC TTT TGG TAG AGG TTT OGG TTT CCC GTC GGG GCT CTT GGT GTC CAC ATG TGG
Pro Ile Glu Lys Thr Ile Ser Lys Ala Lys Gly Gln Pro Arg Glu Pro Gln Val Tyr Thr>

      1390      1400      1410      1420      1430      1440
      *          *          *          *          *          *
CTG CCC CCA TCC CGG GAT GAG CTG ACC AAG AAC CAG GTC AGC CTG ACC TGC CTG GTC AAA
GAC GGG GGT AGG GCC CTA CTC GAC TGG TTC TTG GTC CAG TCG GAC TGG ACG GAC CAG TTT
Leu Pro Pro Ser Arg Asp Glu Leu Thr Lys Asn Gln Val Ser Leu Thr Cys Leu Val Lys>

      1450      1460      1470      1480      1490      1500
      *          *          *          *          *          *
GGC TTC TAT CCC AGC GAC ATC GCC GTG GAG TGG GAG AGC AAT GGG CAG CCG GAG AAC AAC
CCG AAG AEA GGG TCG CTG TAG OGG CAC CTC ACC CTC TCG TTA CCC GTC GGC CTC TTG TTG
Gly Phe Tyr Pro Ser Asp Ile Ala Val Glu Trp Glu Ser Asn Gly Gln Pro Glu Asn Asn>

      1510      1520      1530      1540      1550      1560
      *          *          *          *          *          *
TAC AAG ACC ACG CCT CCC GTG CTG GAC TCC GAC GGC TCC TTC TTC CTC TAC AGC AAG CTC
ATG TTC TGG TGC GGA GGG CAC GAC CTG AGG CTG CCG AGG AAG AAG GAG ATG TCG TTC GAG
Tyr Lys Thr Thr Pro Pro Val Leu Asp Ser Asp Gly Ser Phe Phe Leu Tyr Ser Lys Leu>

      1570      1580      1590      1600      1610      1620
      *          *          *          *          *          *
ACC GTG GAC AAG AGC AGG TGG CAG CAG GGG AAC GTC TTC TCA TGC TCC GTG ATG CAT GAG
TGG CAC CTG TTC TCG TCC ACC GTC GTC CCC TTG CAG AAG AGT ACG AGG CAC TAC GTA CTC
Thr Val Asp Lys Ser Arg Trp Gln Gln Gly Asn Val Phe Ser Cys Ser Val Met His Glu>

```

Fig.13D.

		1630		1640		1650		1660		1670							
	*	*	*	*	*	*	*	*	*	*	*						
GCT	CTG	CAC	AAC	CAC	TAC	ACG	CAG	AAG	AGC	CTC	TCC	CTG	TCT	CCG	GGT	AAA	TGA
CGA	GAC	GTG	TTG	GTG	ATG	TGC	GTC	TTC	TCG	GAG	AGG	GAC	AGA	GGC	CCA	TTT	ACT
Ala	Leu	His	Asn	His	Tyr	Thr	Gln	Lys	Ser	Leu	Ser	Leu	Ser	Pro	Gly	Lys	***>

Fig. 14A.

```

      10      20      30      40      50      60
      *      *      *      *      *      *
ATG GTC AGC TAC TGG GAC ACC GGG GTC CTG CTG TGC GCG CTG CTC AGC TGT CTG CTT CTC
TAC CAG TCG ATG ACC CTG TGG CCC CAG GAC GAC ACG GCG GAC GAG TCG ACA GAC GAA GAG
Met Val Ser Tyr Trp Asp Thr Gly Val Leu Leu Cys Ala Leu Leu Ser Cys Leu Leu Leu>

      70      80      90      100      110      120
      *      *      *      *      *      *
ACA GGA TCT AGT TCC GGA GGT AGA CCT TTC GTA GAG ATG TAC AGT GAA ATC CCC GAA ATT
TGT CCT AGA TCA AGG CCT CCA TCT GGA AAG CAT CTC TAC ATG TCA CTT TAG GGG CTT TAA
Thr Gly Ser Ser Ser Gly Gly Arg Pro Phe Val Glu Met Tyr Ser Glu Ile Pro Glu Ile>

      130      140      150      160      170      180
      *      *      *      *      *      *
ATA CAC ATG ACT GAA GGA AGG GAG CTC GTC ATT CCC TGC GCG GIT ACG TCA CCT AAC ATC
TAT GTG TAC TGA CTT CCT TCC CTC GAG CAG TAA GGG ACG GCC CAA TGC AGT GGA TTG TAG
Ile His Met Thr Glu Gly Arg Glu Leu Val Ile Pro Cys Arg Val Thr Ser Pro Asn Ile>

      190      200      210      220      230      240
      *      *      *      *      *      *
ACT GTT ACT TTA AAA AAG TTT CCA CTT GAC ACT TTG ATC CCT GAT GGA AAA CGC ATA ATC
TGA CAA TGA AAT TTT TTC AAA GGT GAA CTG TGA AAC TAG GGA CTA CCT TTT GCG TAT TAG
Thr Val Thr Leu Lys Lys Phe Pro Leu Asp Thr Leu Ile Pro Asp Gly Lys Arg Ile Ile>

      250      260      270      280      290      300
      *      *      *      *      *      *
TGG GAC AGT AGA AAG GGC TTC ATC ATA TCA AAT GCA ACG TAC AAA GAA ATA GGG CTT CTG
ACC CTG TCA TCT TTC CCG AAG TAG TAT AGT TTA CGT TGC ATG TTT CTT TAT CCC GAA GAC
Trp Asp Ser Arg Lys Gly Phe Ile Ile Ser Asn Ala Thr Tyr Lys Glu Ile Gly Leu Leu>

      310      320      330      340      350      360
      *      *      *      *      *      *
ACC TGT GAA GCA ACA GTC AAT GGG CAT TTG TAT AAG ACA AAC TAT CTC ACA CAT CGA CAA
TGG ACA CTT CGT TGT CAG TTA CCC GTA AAC ATA TTC TGT TTG ATA GAG TGT GTA GCT GTT
Thr Cys Glu Ala Thr Val Asn Gly His Leu Tyr Lys Thr Asn Tyr Leu Thr His Arg Gln>

      370      380      390      400      410      420
      *      *      *      *      *      *
ACC AAT ACA ATC ATA GAT GTC CAA ATA AGC ACA CCA GCG CCA GTC AAA TTA CTT AGA GGC
TGG TTA TGT TAG TAT CTA CAG GTT TAT TCG TGT GGT GCG GGT CAG TTT AAT GAA TCT CCG
Thr Asn Thr Ile Ile Asp Val Gln Ile Ser Thr Pro Arg Pro Val Lys Leu Leu Arg Gly>

      430      440      450      460      470      480
      *      *      *      *      *      *
CAT ACT CTT GTC CTC AAT TGT ACT GCT ACC ACT CCC TTG AAC ACG AGA GTT CAA ATG ACC
GTA TGA GAA CAG GAG TTA ACA TGA CGA TGG TGA GGG AAC TTG TGC TCT CAA GTT TAC TGG
His Thr Leu Val Leu Asn Cys Thr Ala Thr Thr Pro Leu Asn Thr Arg Val Gln Met Thr>

      490      500      510      520      530      540
      *      *      *      *      *      *
TGG AGT TAC CCT GAT GAA ATT GAC CAA AGC AAT TCC CAT GCC AAC ATA TTC TAC AGT GTT
ACC TCA ATG GGA CTA CTT TAA CTG GTT TCG TTA AGG GTA CGG TTG TAT AAG ATG TCA CAA
Trp Ser Tyr Pro Asp Glu Ile Asp Gln Ser Asn Ser His Ala Asn Ile Phe Tyr Ser Val>

```

Fig. 14B.

```

      550      560      570      580      590      600
      *      *      *      *      *      *
CTT ACT ATT GAC AAA ATG CAG AAC AAA GAC AAA GGA CTT TAT ACT TGT CGT GTA AGG AGT
GAA TGA TAA CTG TTT TAC GTC TTG TTT CTG TTT CCT GAA ATA TGA ACA GCA CAT TCC TCA
Leu Thr Ile Asp Lys Met Gln Asn Lys Asp Lys Gly Leu Tyr Thr Cys Arg Val Arg Ser>

      610      620      630      640      650      660
      *      *      *      *      *      *
GGA CCA TCA TTC AAA TCT GTT AAC ACC TCA GTG CAT ATA TAT GAT AAA GCA GGC CCG GGC
CCT GGT AGT AAG TTT AGA CAA TTG TGG AGT CAC GTA TAT ATA CTA TTT CGT CCG GGC CCG
Gly Pro Ser Phe Lys Ser Val Asn Thr Ser Val His Ile Tyr Asp Lys Ala Gly Pro Gly>

      670      680      690      700      710      720
      *      *      *      *      *      *
GAG OCC AAA TCT TGT GAC AAA ACT CAC ACA TGC CCA CCG TGC CCA GCA CCT GAA CTC CTG
CTC GGG TTT AGA ACA CTG TTT TGA GTG TGT ACG GGT GGC ACG GGT CGT GGA CTT GAG GAC
Glu Pro Lys Ser Cys Asp Lys Thr His Thr Cys Pro Pro Cys Pro Ala Pro Glu Leu Leu>

      730      740      750      760      770      780
      *      *      *      *      *      *
GGG GGA CCG TCA GTC TTC CTC TTC CCC CCA AAA OCC AAG GAC ACC CTC ATG ATC TCC CGG
CCC CCT GGC AGT CAG AAG GAG AAG GGG GGT TTT GGG TTC CTG TGG GAG TAC TAG AGG GCC
Gly Gly Pro Ser Val Phe Leu Phe Pro Pro Lys Pro Lys Asp Thr Leu Met Ile Ser Arg>

      790      800      810      820      830      840
      *      *      *      *      *      *
ACC CCT GAG GTC ACA TGC GTG GTG GTG GAC GTG AGC CAC GAA GAC CCT GAG GTC AAG TTC
TGG GGA CTC CAG TGT ACG CAC CAC CAC CTG CAC TCG GTG CTT CTG GGA CTC CAG TTC AAG
Thr Pro Glu Val Thr Cys Val Val Val Asp Val Ser His Glu Asp Pro Glu Val Lys Phe>

      850      860      870      880      890      900
      *      *      *      *      *      *
AAC TGG TAC GTG GAC GGC GTG GAG GTG CAT AAT GCC AAG ACA AAG CCG CGG GAG GAG CAG
TTG ACC ATG CAC CTG CCG CAC CTC CAC GTA TTA CCG TTC TGT TTC GGC GCC CTC CTC GTC
Asn Trp Tyr Val Asp Gly Val Glu Val His Asn Ala Lys Thr Lys Pro Arg Glu Glu Gln>

      910      920      930      940      950      960
      *      *      *      *      *      *
TAC AAC AGC ACG TAC CGT GTG GTC AGC GTC CTC ACC GTC CTG CAC CAG GAC TGG CTG AAT
ATG TTG TCG TGC ATG GCA CAC CAG TCG CAG GAG TGG CAG GAC GTG GTC CTG ACC GAC TTA
Tyr Asn Ser Thr Tyr Arg Val Val Ser Val Leu Thr Val Leu His Gln Asp Trp Leu Asn>

      970      980      990      1000      1010      1020
      *      *      *      *      *      *
GGC AAG GAG TAC AAG TGC AAG GTC TCC AAC AAA GCC CTC CCA GCC CCC ATC GAG AAA ACC
CCG TTC CTC ATG TTC ACG TTC CAG AGG TTG TTT CCG GAG GGT CCG GGG TAG CTC TTT TGG
Gly Lys Glu Tyr Lys Cys Lys Val Ser Asn Lys Ala Leu Pro Ala Pro Ile Glu Lys Thr>

      1030      1040      1050      1060      1070      1080
      *      *      *      *      *      *
ATC TCC AAA GCC AAA GGG CAG CCC CGA GAA CCA CAG GTG TAC ACC CTG CCC CCA TCC CCG
TAG AGG TTT CCG TTT CCC GTC GGG GCT CTT GGT GTC CAC ATG TGG GAC GGG GGT AGG GCC
Ile Ser Lys Ala Lys Gly Gln Pro Arg Glu Pro Gln Val Tyr Thr Leu Pro Pro Ser Arg>

```

Fig. 14C.

```

      1090      1100      1110      1120      1130      1140
      *        *        *        *        *        *
GAT GAG CTG ACC AAG AAC CAG GTC AGC CTG ACC TGC CTG GTC AAA GGC TTC TAT CCC AGC
CTA CTC GAC TGG TTC TTG GTC CAG TCG GAC TGG ACG GAC CAG TTT CCG AAG ATA GGG TCG
Asp Glu Leu Thr Lys Asn Gln Val Ser Leu Thr Cys Leu Val Lys Gly Phe Tyr Pro Ser>

      1150      1160      1170      1180      1190      1200
      *        *        *        *        *        *
GAC ATC GCC GTG GAG TGG GAG AGC AAT GGG CAG CCG GAG AAC AAC TAC AAG ACC ACG CCT
CTG TAG CGG CAC CTC ACC CTC TCG TTA CCC GTC GGC CTC TTG TTG ATG TTC TGG TGC GGA
Asp Ile Ala Val Glu Trp Glu Ser Asn Gly Gln Pro Glu Asn Asn Tyr Lys Thr Thr Pro>

      1210      1220      1230      1240      1250      1260
      *        *        *        *        *        *
CCC GTG CTG GAC TCC GAC GGC TCC TTC TTC CTC TAC AGC AAG CTC ACC GTG GAC AAG AGC
GGG CAC GAC CTG AGG CTG CCG AGG AAG AAG GAG ATG TCG TTC GAG TGG CAC CTG TTC TCG
Pro Val Leu Asp Ser Asp Gly Ser Phe Phe Leu Tyr Ser Lys Leu Thr Val Asp Lys Ser>

      1270      1280      1290      1300      1310      1320
      *        *        *        *        *        *
AGG TGG CAG CAG GGG AAC GTC TTC TCA TGC TCC GTG ATG CAT GAG GCT CTG CAC AAC CAC
TCC ACC GTC GTC CCC TTG CAG AAG AGT ACG AGG CAC TAC GTA CTC CGA GAC GTG TTG GTG
Arg Trp Gln Gln Gly Asn Val Phe Ser Cys Ser Val Met His Glu Ala Leu His Asn His>

      1330      1340      1350
      *        *        *        *        *
TAC ACG CAG AAG AGC CTC TCC CTG TCT CCG GGT AAA TGA
ATG TGC GTC TTC TCG GAG AGG GAC AGA GGC CCA TTT ACT
Tyr Thr Gln Lys Ser Leu Ser Leu Ser Pro Gly Lys ***>

```

Fig.15A.

```

      10      20      30      40      50      60
      *      *      *      *      *      *
ATG GTC AGC TAC TGG GAC ACC GGG GTC CTG CTG TGC GCG CTG CTC AGC TGT CTG CTT CTC
TAC CAG TCG ATG ACC CTG TGG CCC CAG GAC GAC ACG CCG GAC GAG TCG ACA GAC GAA GAG
Met Val Ser Tyr Trp Asp Thr Gly Val Leu Leu Cys Ala Leu Leu Ser Cys Leu Leu Leu>

      70      80      90      100     110     120
      *      *      *      *      *      *
ACA GGA TCT AGT TCC GGA GGT AGA CCT TTC GTA GAG ATG TAC AGT GAA ATC CCC GAA ATT
TGT CCT AGA TCA AGG CCT CCA TCT GGA AAG CAT CTC TAC ATG TCA CTT TAG GGG CTT TAA
Thr Gly Ser Ser Ser Gly Gly Arg Pro Phe Val Glu Met Tyr Ser Glu Ile Pro Glu Ile>

      130     140     150     160     170     180
      *      *      *      *      *      *
ATA CAC ATG ACT GAA GGA AGG GAG CTC GTC ATT CCC TGC CCG GTT ACG TCA CCT AAC ATC
TAT GTG TAC TGA CTT CCT TCC CTC GAG CAG TAA GGG ACG GCC CAA TGC AGT GGA TTG TAG
Ile His Met Thr Glu Gly Arg Glu Leu Val Ile Pro Cys Arg Val Thr Ser Pro Asn Ile>

      190     200     210     220     230     240
      *      *      *      *      *      *
ACT GTT ACT TTA AAA AAG TTT CCA CTT GAC ACT TTG ATC CCT GAT GGA AAA CCG ATA ATC
TGA CAA TGA AAT TTT TTC AAA GGT GAA CTG TGA AAC TAG GGA CTA CCT TTT GCG TAT TAG
Thr Val Thr Leu Lys Lys Phe Pro Leu Asp Thr Leu Ile Pro Asp Gly Lys Arg Ile Ile>

      250     260     270     280     290     300
      *      *      *      *      *      *
TGG GAC AGT AGA AAG GGC TTC ATC ATA TCA AAT GCA ACG TAC AAA GAA ATA GGG CTT CTG
ACC CTG TCA TCT TTC CCG AAG TAG TAT AGT TTA CGT TGC ATG TTT CTT TAT CCC GAA GAC
Trp Asp Ser Arg Lys Gly Phe Ile Ile Ser Asn Ala Thr Tyr Lys Glu Ile Gly Leu Leu>

      310     320     330     340     350     360
      *      *      *      *      *      *
ACC TGT GAA GCA ACA GTC AAT GGG CAT TTG TAT AAG ACA AAC TAT CTC ACA CAT CGA CAA
TGG ACA CTT CGT TGT CAG TTA CCC GTA AAC ATA TTC TGT TTG ATA GAG TGT GTA GCT GTT
Thr Cys Glu Ala Thr Val Asn Gly His Leu Tyr Lys Thr Asn Tyr Leu Thr His Arg Gln>

      370     380     390     400     410     420
      *      *      *      *      *      *
ACC AAT ACA ATC ATA GAT GTC CAA ATA AGC ACA CCA CGC CCA GTC AAA TTA CTT AGA GGC
TGG TTA TGT TAG TAT CTA CAG GTT TAT TCG TGT GGT GCG GGT CAG TTT AAT GAA TCT CCG
Thr Asn Thr Ile Ile Asp Val Gln Ile Ser Thr Pro Arg Pro Val Lys Leu Leu Arg Gly>

      430     440     450     460     470     480
      *      *      *      *      *      *
CAT ACT CTT GTC CTC AAT TGT ACT GCT ACC ACT CCC TTG AAC ACG AGA GTT CAA ATG ACC
GTA TGA GAA CAG GAG TTA ACA TGA CGA TGG TGA GGG AAC TTG TGC TCT CAA GTT TAC TGG
His Thr Leu Val Leu Asn Cys Thr Ala Thr Thr Pro Leu Asn Thr Arg Val Gln Met Thr>

      490     500     510     520     530     540
      *      *      *      *      *      *
TGG AGT TAC CCT GAT GAA AAA AAT AAG AGA GCT TCC GTA AGG CGA CGA ATT GAC CAA AGC
ACC TCA ATG GGA CTA CTT TTT TTA TTC TCT CGA AGG CAT TCC GCT GCT TAA CTG GTT TCG
Trp Ser Tyr Pro Asp Glu Lys Asn Lys Arg Ala Ser Val Arg Arg Arg Ile Asp Gln Ser>

```

Fig.15B.

```

      550      560      570      580      590      600
      *      *      *      *      *      *
AAT TCC CAT GCC AAC ATA TTC TAC AGT GTT CTT ACT ATT GAC AAA ATG CAG AAC AAA GAC
TTA AGG GTA CCG TTG TAT AAG ATG TCA CAA GAA TGA TAA CTG TTT TAC GTC TTG TTT CTG
Asn Ser His Ala Asn Ile Phe Tyr Ser Val Leu Thr Ile Asp Lys Met Gln Asn Lys Asp>

      610      620      630      640      650      660
      *      *      *      *      *      *
AAA GGA CTT TAT ACT TGT CGT GTA AGG AGT GGA CCA TCA TTC AAA TCT GTT AAC ACC TCA
TTT CCT GAA ATA TGA ACA GCA CAT TCC TCA CCT GGT AGT AAG TTT AGA CAA TTG TGG AGT
Lys Gly Leu Tyr Thr Cys Arg Val Arg Ser Gly Pro Ser Phe Lys Ser Val Asn Thr Ser>

      670      680      690      700      710      720
      *      *      *      *      *      *
GTG CAT ATA TAT GAT AAA GCA GGC CCG GGC GAG CCC AAA TCT TGT GAC AAA ACT CAC ACA
CAC GTA TAT ATA CTA TTT CGT CCG GGC CCG CTC GGG TTT AGA ACA CTG TTT TGA GTG TGT
Val His Ile Tyr Asp Lys Ala Gly Pro Gly Glu Pro Lys Ser Cys Asp Lys Thr His Thr>

      730      740      750      760      770      780
      *      *      *      *      *      *
TGC CCA CCG TGC CCA GCA CCT GAA CTC CTG GGG GGA CCG TCA GTC TTC CTC TTC OCC CCA
ACG GGT GGC ACG GGT CGT GGA CTT GAG GAC CCC CCT GGC AGT CAG AAG GAG AAG GGG GGT
Cys Pro Pro Cys Pro Ala Pro Glu Leu Leu Gly Gly Pro Ser Val Phe Leu Phe Pro Pro>

      790      800      810      820      830      840
      *      *      *      *      *      *
AAA CCC AAG GAC ACC CTC ATG ATC TCC CGG ACC CCT GAG GTC ACA TGC GTG GTG GTG GAC
TTT GGG TTC CTG TGG GAG TAC TAG AGG GCC TGG GGA CTC CAG TGT ACG CAC CAC CAC CTG
Lys Pro Lys Asp Thr Leu Met Ile Ser Arg Thr Pro Glu Val Thr Cys Val Val Val Asp>

      850      860      870      880      890      900
      *      *      *      *      *      *
GTG AGC CAC GAA GAC CCT GAG GTC AAG TTC AAC TGG TAC GTG GAC GGC GTG GAG GTG CAT
CAC TGG GTG CTT CTG GGA CTC CAG TTC AAG TTG ACC ATG CAC CTG CCG CAC CTC CAC GTA
Val Ser His Glu Asp Pro Glu Val Lys Phe Asn Trp Tyr Val Asp Gly Val Glu Val His>

      910      920      930      940      950      960
      *      *      *      *      *      *
AAT GCC AAG ACA AAG CCG CCG GAG GAG CAG TAC AAC AGC ACG TAC CGT GTG GTC AGC GTC
TTA CCG TTC TGT TTC GGC GCC CTC CTC GTC ATG TTG TCG TGC ATG GCA CAC CAG TCG CAG
Asn Ala Lys Thr Lys Pro Arg Glu Glu Gln Tyr Asn Ser Thr Tyr Arg Val Val Ser Val>

      970      980      990      1000      1010      1020
      *      *      *      *      *      *
CTC ACC GTC CTG CAC CAG GAC TGG CTG AAT GGC AAG GAG TAC AAG TGC AAG GTC TCC AAC
GAG TGG CAG GAC GTG GTC CTG ACC GAC TTA CCG TTC CTC ATG TTC ACG TTC CAG AGG TTG
Leu Thr Val Leu His Gln Asp Trp Leu Asn Gly Lys Glu Tyr Lys Cys Lys Val Ser Asn>

      1030      1040      1050      1060      1070      1080
      *      *      *      *      *      *
AAA GCC CTC CCA GCC CCC ATC GAG AAA ACC ATC TCC AAA GCC AAA GGG CAG CCC OGA GAA
TTT CCG GAG GGT CCG GGG TAG CTC TTT TGG TAG AGG TTT CCG TTT CCC GTC GGG GCT CTT
Lys Ala Leu Pro Ala Pro Ile Glu Lys Thr Ile Ser Lys Ala Lys Gly Gln Pro Arg Glu>

```

Fig.15C.

```

      1090      1100      1110      1120      1130      1140
      *          *          *          *          *          *
CCA CAG GTG TAC ACC CTG CCC CCA TCC CGG GAT GAG CTG ACC AAG AAC CAG GTC AGC CTG
GGT GTC CAC ATG TGG GAC GGG GGT AGG GGC CTA CTC GAC TGG TTC TTG GTC CAG TCG GAC
Pro Gln Val Tyr Thr Leu Pro Pro Ser Arg Asp Glu Leu Thr Lys Asn Gln Val Ser Leu>

      1150      1160      1170      1180      1190      1200
      *          *          *          *          *          *
ACC TGC CTG GTC AAA GGC TTC TAT CCC AGC GAC ATC GCC GTG GAG TGG GAG AGC AAT GGG
TGG ACG GAC CAG TTT CCG AAG ATA GGG TCG CTG TAG CGG CAC CTC ACC CTC TCG TTA CCC
Thr Cys Leu Val Lys Gly Phe Tyr Pro Ser Asp Ile Ala Val Glu Trp Glu Ser Asn Gly>

      1210      1220      1230      1240      1250      1260
      *          *          *          *          *          *
CAG CCG GAG AAC AAC TAC AAG ACC ACG CCT CCC GTG CTG GAC TCC GAC GGC TCC TTC TTC
GTC GGC CTC TTG TTG ATG TTC TGG TGC GGA GGG CAC GAC CTG AGG CTG CCG AGG AAG AAG
Gln Pro Glu Asn Asn Tyr Lys Thr Thr Pro Pro Val Leu Asp Ser Asp Gly Ser Phe Phe>

      1270      1280      1290      1300      1310      1320
      *          *          *          *          *          *
CTC TAC AGC AAG CTC ACC GTG GAC AAG AGC AGG TGG CAG CAG GGG AAC GTC TTC TCA TGC
GAG ATG TCG TTC GAG TGG CAC CTG TTC TCG TCC ACC GTC GTC CCC TTG CAG AAG AGT ACG
Leu Tyr Ser Lys Leu Thr Val Asp Lys Ser Arg Trp Gln Gln Gly Asn Val Phe Ser Cys>

      1330      1340      1350      1360      1370      1380
      *          *          *          *          *          *
TCC GTG ATG CAT GAG GCT CTG CAC AAC CAC TAC ACG CAG AAG AGC CTC TCC CTG TCT CCG
AGG CAC TAC GTA CTC CGA GAC GTG TTG GTG ATG TGC GTC TTC TCG GAG AGG GAC AGA GGC
Ser Val Met His Glu Ala Leu His Asn His Tyr Thr Gln Lys Ser Leu Ser Leu Ser Pro>

      *
GGT AAA TGA
CCA TTT ACT
Gly Lys ****>

```

Fig.16A.

```

      10      20      30      40      50      60
      *      *      *      *      *      *
ATG GTC AGC TAC TGG GAC ACC GGG GTC CTG CTG TGC GCG CTG CTC AGC TGT CTG CTT CTC
TAC CAG TCG ATG ACC CTG TGG CCC CAG GAC GAC ACG CGC GAC GAG TCG ACA GAC GAA GAG
Met Val Ser Tyr Trp Asp Thr Gly Val Leu Leu Cys Ala Leu Leu Ser Cys Leu Leu Leu>

      70      80      90      100     110     120
      *      *      *      *      *      *
ACA GGA TCT AGT TCA GGT TCA AAA TTA AAA GAT CCT GAA CTG AGT TTA AAA GGC ACC CAG
TGT CCT AGA TCA AGT CCA AGT TTT AAT TTT CTA GGA CTT GAC TCA AAT TTT CCG TGG GTC
Thr Gly Ser Ser Ser Gly Ser Lys Leu Lys Asp Pro Glu Leu Ser Leu Lys Gly Thr Gln>

      130     140     150     160     170     180
      *      *      *      *      *      *
CAC ATC ATG CAA GCA GGC CAG ACA CTG CAT CTC CAA TGC AGG GGG GAA GCA GCC CAT AAA
GTG TAG TAC GTT CGT CCG GTC TGT GAC GTA GAG GTT ACG TCC CCC CTT CGT CCG GTA TTT
His Ile Met Gln Ala Gly Gln Thr Leu His Leu Gln Cys Arg Gly Glu Ala Ala His Lys>

      190     200     210     220     230     240
      *      *      *      *      *      *
TGG TCT TTG CCT GAA ATG GTG AGT AAG GAA AGC GAA AGG CTG AGC ATA ACT AAA TCT GCC
ACC AGA AAC GGA CTT TAC CAC TCA TTC CTT TCG CTT TCC GAC TCG TAT TGA TTT AGA CGG
Trp Ser Leu Pro Glu Met Val Ser Lys Glu Ser Glu Arg Leu Ser Ile Thr Lys Ser Ala>

      250     260     270     280     290     300
      *      *      *      *      *      *
TGT GGA AGA AAT GGC AAA CAA TTC TGC AGT ACT TTA ACC TTG AAC ACA GCT CAA GCA AAC
ACA CCT TCT TTA CCG TTT GTT AAG ACG TCA TGA AAT TGG AAC TTG TGT CGA GTT CGT TTG
Cys Gly Arg Asn Gly Lys Gln Phe Cys Ser Thr Leu Thr Leu Asn Thr Ala Gln Ala Asn>

      310     320     330     340     350     360
      *      *      *      *      *      *
CAC ACT GGC TTC TAC AGC TGC AAA TAT CTA GCT GTA CCT ACT TCA AAG AAG AAG GAA ACA
GTG TGA CCG AAG ATG TCG ACG TTT ATA GAT CGA CAT GGA TGA AGT TTC TTC TTC CTT TGT
His Thr Gly Phe Tyr Ser Cys Lys Tyr Leu Ala Val Pro Thr Ser Lys Lys Lys Glu Thr>

      370     380     390     400     410     420
      *      *      *      *      *      *
GAA TCT GCA ATC TAT ATA TTT ATT AGT GAT ACA GGT AGA CCT TTC GTA GAG ATG TAC AGT
CTT AGA CGT TAG ATA TAT AAA TAA TCA CTA TGT CCA TCT GGA AAG CAT CTC TAC ATG TCA
Glu Ser Ala Ile Tyr Ile Phe Ile Ser Asp Thr Gly Arg Pro Phe Val Glu Met Tyr Ser>

      430     440     450     460     470     480
      *      *      *      *      *      *
GAA ATC CCC GAA ATT ATA CAC ATG ACT GAA GGA AGG GAG CTC GTC ATT CCC TGC CCG GTT
CTT TAG GGG CTT TAA TAT GTG TAC TGA CTT CCT TCC CTC GAG CAG TAA GGG ACG GCC CAA
Glu Ile Pro Glu Ile Ile His Met Thr Glu Gly Arg Glu Leu Val Ile Pro Cys Arg Val>

      490     500     510     520     530     540
      *      *      *      *      *      *
ACG TCA CCT AAC ATC ACT GTT ACT TTA AAA AAG TTT CCA CTT GAC ACT TTG ATC CCT GAT
TGC AGT GGA TTG TAG TGA CAA TGA AAT TTT TTC AAA GGT GAA CTG TGA AAC TAG GGA CTA
Thr Ser Pro Asn Ile Thr Val Thr Leu Lys Lys Phe Pro Leu Asp Thr Leu Ile Pro Asp>

```

Fig. 16B.

```

      550      560      570      580      590      600
      *      *      *      *      *      *
GGA AAA CGC ATA ATC TGG GAC AGT AGA AAG GGC TTC ATC ATA TCA AAT GCA ACG TAC AAA
CCT TTT GCG TAT TAG ACC CTG TCA TCT TTC CCG AAG TAG TAT AGT TTA CGT TGC ATG TTT
Gly Lys Arg Ile Ile Trp Asp Ser Arg Lys Gly Phe Ile Ile Ser Asn Ala Thr Tyr Lys>

      610      620      630      640      650      660
      *      *      *      *      *      *
GAA ATA GGG CTT CTG ACC TGT GAA GCA ACA GTC AAT GGG CAT TTG TAT AAG ACA AAC TAT
CTT TAT CCC GAA GAC TGG ACA CTT CGT TGT CAG TTA CCC GTA AAC ATA TTC TGT TTG ATA
Glu Ile Gly Leu Leu Thr Cys Glu Ala Thr Val Asn Gly His Leu Tyr Lys Thr Asn Tyr>

      670      680      690      700      710      720
      *      *      *      *      *      *
CTC ACA CAT CGA CAA ACC AAT ACA ATC ATR GAT GTC CAA ATA AGC ACA CCA CGC CCA GTC
GAG TGT GTA GCT GTT TGG TTA TGT TAG TAT CTA CAG GTT TAT TCG TGT GGT GCG GGT CAG
Leu Thr His Arg Gln Thr Asn Thr Ile Ile Asp Val Gln Ile Ser Thr Pro Arg Pro Val>

      730      740      750      760      770      780
      *      *      *      *      *      *
AAA TTA CTT AGA GGC CAT ACT CTT GTC CTC AAT TGT ACT GCT ACC ACT CCC TTG AAC ACG
TTT AAT GAA TCT CCG GTA TGA GAA CAG GAG TTA ACA TGA CGA TGG TGA GGG AAC TTG TGC
Lys Leu Leu Arg Gly His Thr Leu Val Leu Asn Cys Thr Ala Thr Thr Pro Leu Asn Thr>

      790      800      810      820      830      840
      *      *      *      *      *      *
AGA GTT CAA ATG ACC TGG AGT TAC CCT GAT GAA AAA AAT AAG AAC GCT TCC GTA AGG CGA
TCT CAA GTT TAC TGG ACC TCA ATG GGA CTA CTT TTT TTA TTC TTG CGA AGG CAT TCC GCT
Arg Val Gln Met Thr Trp Ser Tyr Pro Asp Glu Lys Asn Lys Asn Ala Ser Val Arg Arg>

      850      860      870      880      890      900
      *      *      *      *      *      *
CGA ATT GAC CAA AGC AAT TCC CAT GCC AAC ATA TTC TAC AGT GTT CTT ACT ATT GAC AAA
GCT TAA CTG GTT TCG TTA AGG GTA CCG TTG TAT AAG ATG TCA CAA GAA TGA TAA CTG TTT
Arg Ile Asp Gln Ser Asn Ser His Ala Asn Ile Phe Tyr Ser Val Leu Thr Ile Asp Lys>

      910      920      930      940      950      960
      *      *      *      *      *      *
ATG CAG AAC AAA GAC AAA GGA CTT TAT ACT TGT CGT GTA AGG AGT GGA CCA TCA TTC AAA
TAC GTC TTG TTT CTG TTT CCT GAA ATA TGA ACA GCA CAT TCC TCA CCT GGT AGT AAG TTT
Met Gln Asn Lys Asp Lys Gly Leu Tyr Thr Cys Arg Val Arg Ser Gly Pro Ser Phe Lys>

      970      980      990      1000      1010      1020
      *      *      *      *      *      *
TCT GTT AAC ACC TCA GTG CAT ATA TAT GAT AAA GCA GGC CCG GGC GAG CCC AAA TCT TGT
AGA CAA TTG TGG AGT CAC GTA TAT ATA CTA TTT CGT CCG GGC CCG CTC GGG TTT AGA ACA
Ser Val Asn Thr Ser Val His Ile Tyr Asp Lys Ala Gly Pro Gly Glu Pro Lys Ser Cys>

      1030      1040      1050      1060      1070      1080
      *      *      *      *      *      *
GAC AAA ACT CAC ACA TGC CCA CCG TGC CCA GCA CCT GAA CTC CTG GGG GGA CCG TCA GTC
CTG TTT TGA GTG TGT ACG GGT GGC ACG GGT CGT GGA CTT GAG GAC CCC CCT GGC AGT CAG
Asp Lys Thr His Thr Cys Pro Pro Cys Pro Ala Pro Glu Leu Leu Gly Gly Pro Ser Val>

```

Fig. 16C.

```

      1090      1100      1110      1120      1130      1140
      *        *        *        *        *        *
TTC CTC TTC CCC CCA AAA CCC AAG GAC ACC CTC ATG ATC TCG CGG ACC CCT GAG GTC ACA
AAG GAG AAG GGG GGT TTT GGG TTC CTG TGG GAG TAC TAG AGG GCC TGG GGA CTC CAG TGT
Phe Leu Phe Pro Pro Lys Pro Lys Asp Thr Leu Met Ile Ser Arg Thr Pro Glu Val Thr>

      1150      1160      1170      1180      1190      1200
      *        *        *        *        *        *
TGC GTG GTG GTG GAC GTG AGC CAC GAA GAC CCT GAG GTC AAG TTC AAC TGG TAC GTG GAC
ACG CAC CAC CAC CTG CAC TCG GTG CTT CTG GGA CTC CAG TTC AAG TTG ACC ATG CAC CTG
Cys Val Val Val Asp Val Ser His Glu Asp Pro Glu Val Lys Phe Asn Trp Tyr Val Asp>

      1210      1220      1230      1240      1250      1260
      *        *        *        *        *        *
GGC GTG GAG GTG CAT AAT GCC AAG ACA AAG CCG CGG GAG GAG CAG TAC AAC AGC ACG TAC
CCG CAC CTC CAC GTA TTA CCG TTC TGT TTC GGC GCC CTC CTC GTC ATG TTG TCG TGC ATG
Gly Val Glu Val His Asn Ala Lys Thr Lys Pro Arg Glu Glu Gln Tyr Asn Ser Thr Tyr>

      1270      1280      1290      1300      1310      1320
      *        *        *        *        *        *
CGT GTG GTC AGC GTC CTC ACC GTC CTG CAC CAG GAC TGG CTG AAT GGC AAG GAG TAC AAG
GCA CAC CAG TCG CAG GAG TGG CAG GAC GTG GTC CTG ACC GAC TTA CCG TTC CTC ATG TTC
Arg Val Val Ser Val Leu Thr Val Leu His Gln Asp Trp Leu Asn Gly Lys Glu Tyr Lys>

      1330      1340      1350      1360      1370      1380
      *        *        *        *        *        *
TGC AAG GTC TCC AAC AAA GCC CTC CCA GCC CCC ATC GAG AAA ACC ATC TCC AAA GCC AAA
ACG TTC CAG AGG TTG TTT CCG GAG GGT CCG GGG TAG CTC TTT TGG TAG AGG TTT CCG TTT
Cys Lys Val Ser Asn Lys Ala Leu Pro Ala Pro Ile Glu Lys Thr Ile Ser Lys Ala Lys>

      1390      1400      1410      1420      1430      1440
      *        *        *        *        *        *
GGG CAG CCC CGA GAA CCA CAG GTG TAC ACC CTG CCC CCA TCC CCG GAT GAG CTG ACC AAG
CCC GTC GGG GCT CTT GGT GTC CAC ATG TGG GAC GGG GGT AGG GCC CTA CTC GAC TGG TTC
Gly Gln Pro Arg Glu Pro Gln Val Tyr Thr Leu Pro Pro Ser Arg Asp Glu Leu Thr Lys>

      1450      1460      1470      1480      1490      1500
      *        *        *        *        *        *
AAC CAG GTC AGC CTG ACC TGC CTG GTC AAA GGC TTC TAT CCC AGC GAC ATC GCC GTG GAG
TTG GTC CAG TCG GAC TGG ACG GAC CAG TTT CCG AAG ATA GGG TCG CTG TAG CCG CAC CTC
Asn Gln Val Ser Leu Thr Cys Leu Val Lys Gly Phe Tyr Pro Ser Asp Ile Ala Val Glu>

      1510      1520      1530      1540      1550      1560
      *        *        *        *        *        *
TGG GAG AGC AAT GGG CAG CCG GAG AAC AAC TAC AAG ACC ACG CCT CCC GTG CTG GAC TCC
ACC CTC TCG TTA CCC GTC GGC CTC TTG TTG ATG TTC TGG TGC GGA GGG CAC GAC CTG AGG
Trp Glu Ser Asn Gly Gln Pro Glu Asn Asn Tyr Lys Thr Thr Pro Pro Val Leu Asp Ser>

      1570      1580      1590      1600      1610      1620
      *        *        *        *        *        *
GAC GGC TCC TTC TTC CTC TAC AGC AAG CTC ACC GTG GAC AAG AGC AGG TGG CAG CAG GGG
CTG CCG AGG AAG AAG GAG ATG TCG TTC GAG TGG CAC CTG TTC TCG TCC ACC GTC GTC CCC
Asp Gly Ser Phe Phe Leu Tyr Ser Lys Leu Thr Val Asp Lys Ser Arg Trp Gln Gln Gly>

```

Fig.16D.

```

      1630      1640      1650      1660      1670      1680
      *        *        *        *        *        *
AAC GTC TTC TCA TGC TCC GTG ATG CAT GAG GCT CTG CAC AAC CAC TAC ACG CAG AAG AGC
TTG CAG AAG AGT ACG AGG CAC TAC GTA CTC CGA GAC GTG TTG GTG ATG TGC GTC TTC TCG
Asn Val Phe Ser Cys Ser Val Met His Glu Ala Leu His Asn His Tyr Thr Gln Lys Ser>

      1690      1700
      *        *        *        *
CTC TCC CTG TCT CCG GGT AAA TGA
GAG AGG GAC AGA GGC CCA TTT ACT
Leu Ser Leu Ser Pro Gly Lys ***>
```

Fig.17.

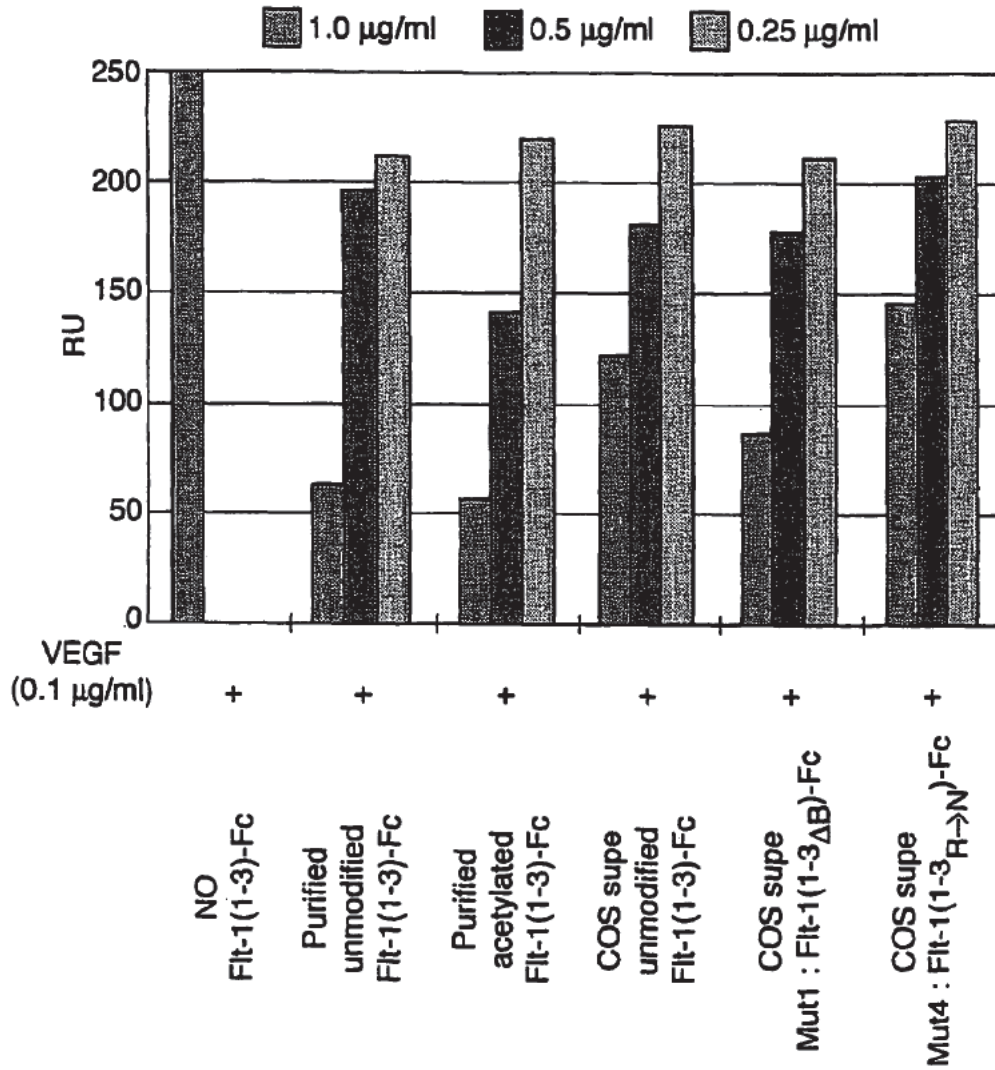

Fig.18.

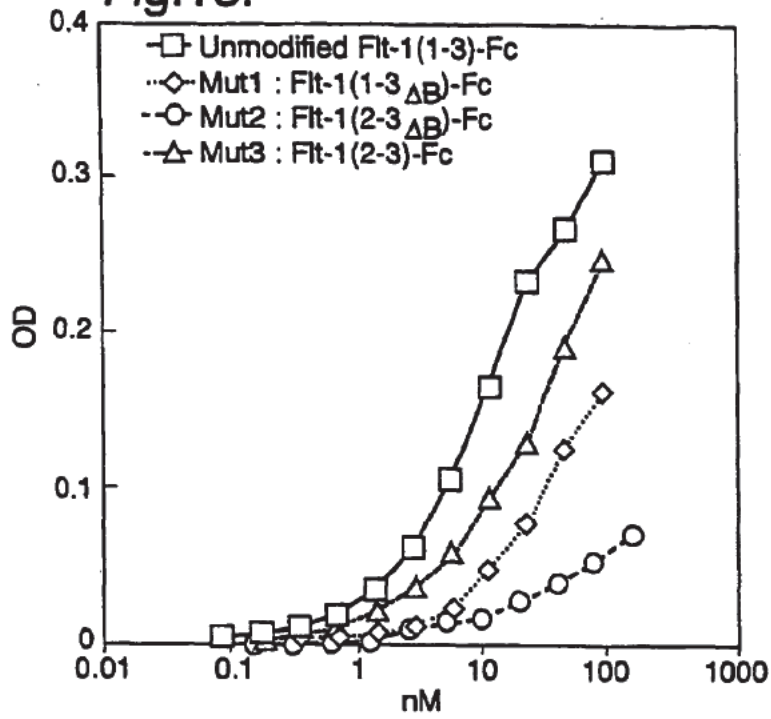

Fig.19.

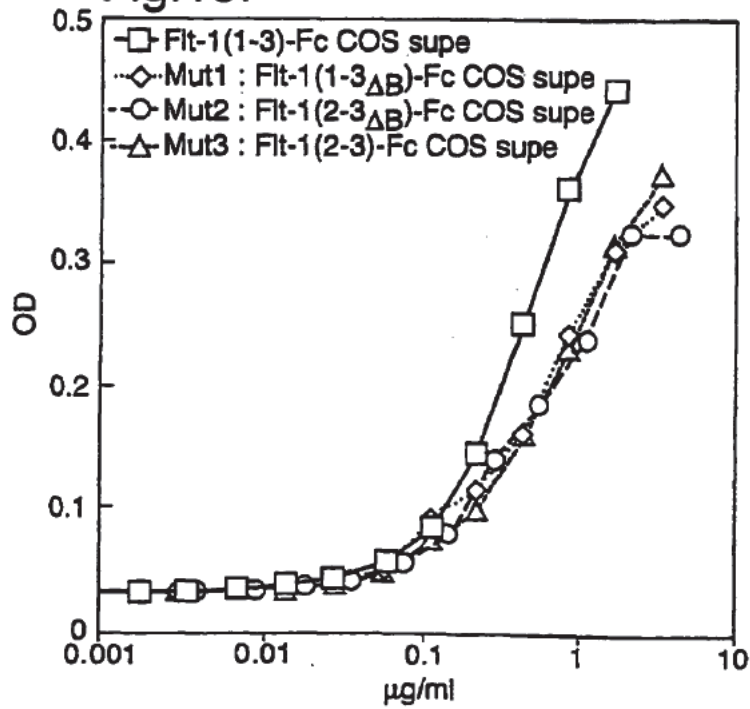

Fig.20.

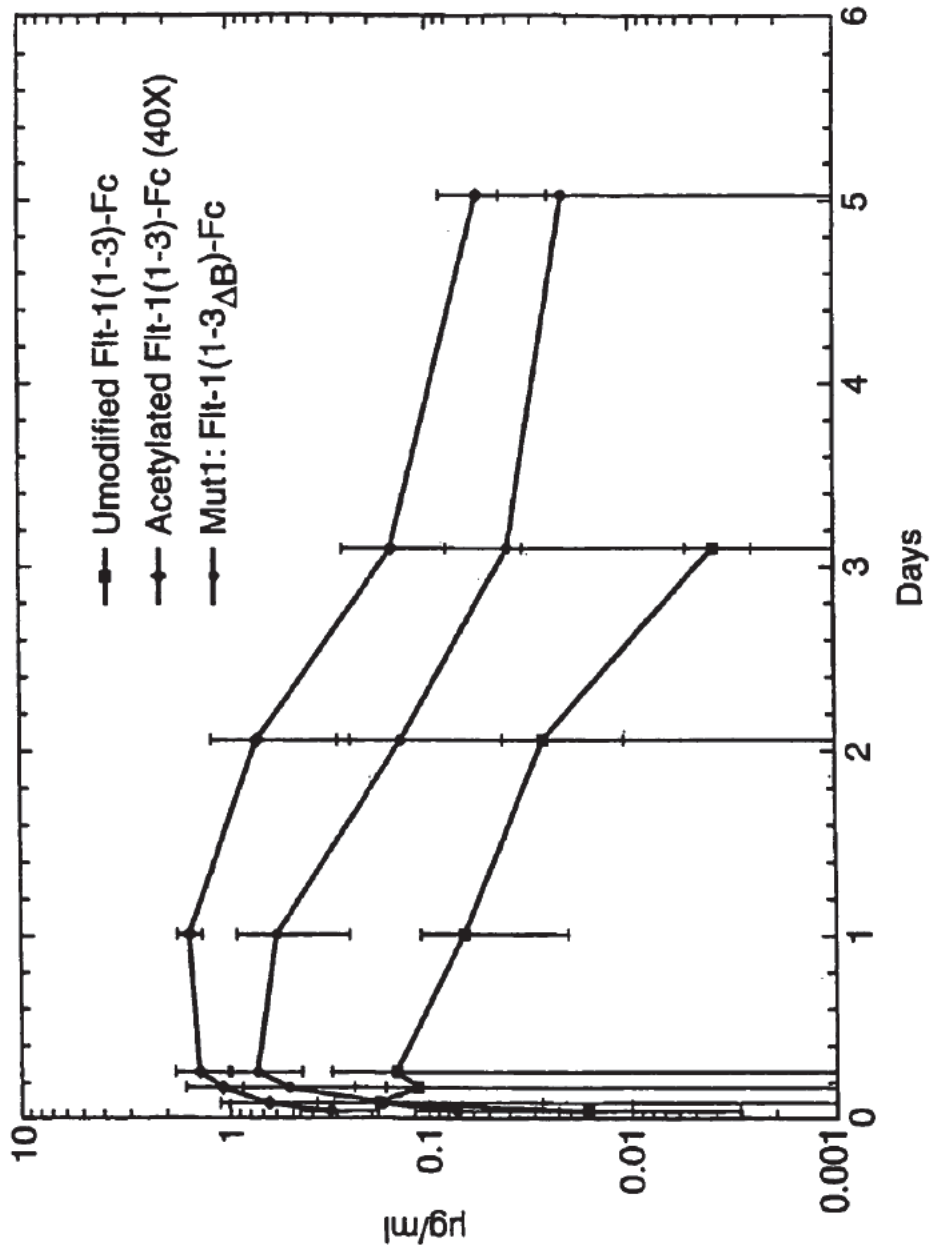

Fig.21A.

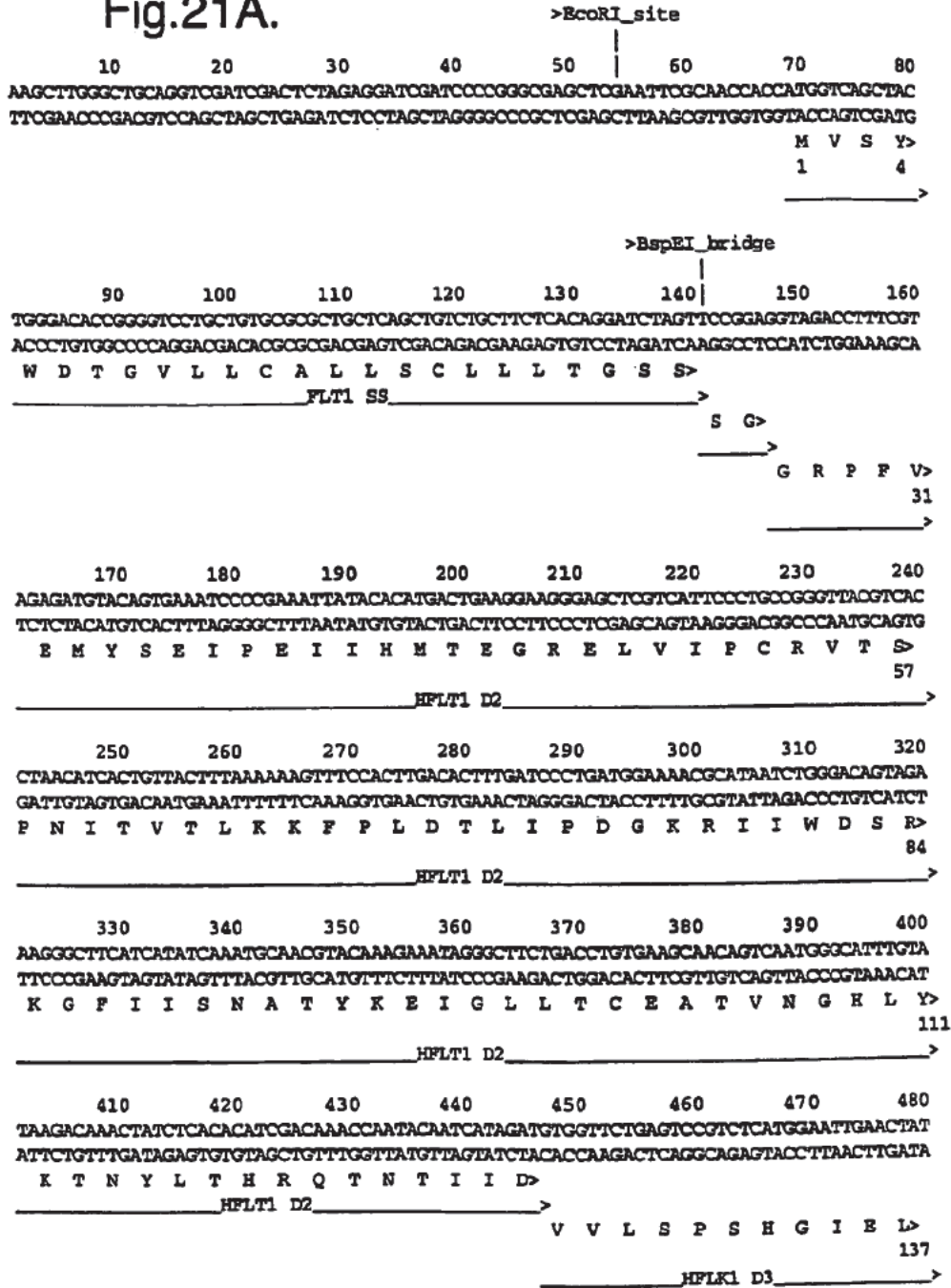

Fig.21B.

490 500 510 520 530 540 550 560
 CTGTTGGAGAAAAGCTTGTCTTAAATGTACAGCAAGAACTGAACTAAATGTGGGGATTGACTTCAACTGGGAATACCT
 GACAACTCTTTTCGAACAGAATTTAACATGTGGTCTTGGACTTGATTACACCCCTAACTGAAGTTGACCCCTATGGGA
 S V G E K L V L N C T A R T E L N V G I D F N W E Y P >
 164

 HFLK1 D3 >

570 580 590 600 610 620 630 640
 TCTTGAAGCATCAGCATAGAAACTTGTAAACCGAGACCTAAAAACCCAGTCTGGGAGTGAGATGAAGAAATTTTGGAG
 AGAAGCTTCGTAGTCGTATCTTTGAACATTTGGCTCTGGATTTTGGGTGAGACCCCTCACTCTACTTCTTTAAAACTC
 S S K H Q H K K L V N R D L K T Q S G S E M K K F L S >
 191

 HFLK1 D3 >

650 660 670 680 690 700 710 720
 CACCTTAACATAGATGGTGTAAACCCGGAGTGACCAAGGATTGTACACCTGTGCAGCATCCAGTGGGCTGATGACCAAGA
 GTGGAAATGATATCTACCACATGGGGCTCACTGGTTCCTAACATGTGGACACGTCGTAGGTACCCOGACTACTGGTCT
 T L T I D G V T R S D Q G L Y T C A A S S G L M T K >
 217

 HFLK1 D3 >

>Srf_Bridge_
 730 740 750 | 760 770 780 790 800
 AGAACAGCACATTTGTCCAGGGTCCATGAAAAGGGCCCGGGGACAAAACCTCACACATGCCACCCTGCCAGCACCTGAA
 TCTTGTCTGTAAACAGTCCAGGTACTTTCCCGGGCCCGCTGTTTGTAGTGTGTACGGGTGGCACGGGTCTGGACTT
 K N S T F V R V H E K >

 HFLK1 D3 >

G P G >

 D K T H T C P P C P A P E >
 244

 FCAC1 (A) >

810 820 830 840 850 860 870 880
 CTCCTGGGGGACCGTCACTCTTCTTCCCCCAAAACCAAGGACACCCCTCATGATCTCCCGGACCCCTGAGGTCA
 GAGGACCCCTTGGCAGTCAGAGGAGAGGGGGTTTGGGTTCCTGTGGGAGTACTAGAGGGCTGGGGACTCCAATG
 L L G G P S V F L P P P K P K D T L M I S R T P B V T >
 271

 FCAC1 (A) >

890 900 910 920 930 940 950 960
 ATGCGTGGTGGTGGAGCGTGAGCCAGGAGACCCCTGAGGTCAAGTTCAACTGGTACGTGGACGGCGTGGAGGTGCAATATG
 TAGGCACACCACCTGCACCTCGGTGCTTCTGGGACTCCAGTTCAGTTGACCATGCACCTGCCCGCACCTCCACGTATTAC
 C V V V D V S H E D P E V K F N W Y V D G V E V H N >
 297

 FCAC1 (A) >

970 980 990 1000 1010 1020 1030 1040
 CCAAGACAAAGCCCGGGGAGGAGCAGTACAACAGCACGTACCGTGTGGTCAAGTTCACCGTCTGCACCAGGACTGG
 GGTCTGTCTTGGGCCCTTCTCGTCATGTGTGCGTGCATGGCACACCAGTCCGAGGAGTGGCAGGACGTGGTCTGACC
 A K T K P R E E Q Y N S T Y R V V S V L T V L H Q D W >
 324

 FCAC1 (A) >

Fig.21C.

1050 1060 1070 1080 1090 1100 1110 1120
 CTGAATGGCAAGGAGTACAAGTGCAGGTCCTCCAACAAAGCCCTCCAGCCCCCATCGAGAAAACCATCTCCAAGGCCAA
 GACTTACCGTTCCTCATGTTCAAGTTCACAGGTTGTTTCGGGAGGGTCGGGGGTAGCTCTTTTGGTAGAGGTTTCGGTT
 L N G K E Y K C K V S N K A L P A P I E K T I S K A K>
 351
 _____FCAC1 (A)_____>

>A>C_Aallotype
 |
 >G>T_Aallotype
 | |
 1130 1140 1150 1160 1170 1180 1190 1200
 AGGGCAGCCCCGAGAACCCACAGGTGTACACCCCTGCCCCOCATCCCGGGATGAGCTGACCAAGAACCAGGTGAGCCTGACCT
 TCCCGTCCGGGCTCTTGGTGTCCACATGTGGGACGGGGTACGGCCCTACTCCGACTGGTTCCTGGTCCAGTCCGACTGGA
 G Q P R E P Q V Y T L P P S R D E L T K N Q V S L T>
 377
 _____FCAC1 (A)_____>

1210 1220 1230 1240 1250 1260 1270 1280
 GCCTGGTCAAAGGCTTCTATCCAGGACATCGCCGTGGAGTGGGAGAGCAATGGCCAGCCGGAGAACCACTACAAGACC
 CGGACCAAGTTTCCGAAGATAGGGTCGCTGTAGCGGCAACCTCACCCCTCTCGTTACCCGTCGGCCCTCTTGTGTGATGTTCTGG
 C L V K G P Y P S D I A V E W B S N G Q P E N N Y K T>
 404
 _____FCAC1 (A)_____>

>T>C
 |
 1290 1300 1310 1320 1330 1340 1350 1360
 ACGCCCTCCCGTGCCTGGACTCCGACGGCTCCCTTCTTCTCTATAGCAAGCTCACCCGTGGACAAGAGCAGGTGGCAGCAGGG
 TCCGGAGGGCACGACCTGAGGCTGCCGAGGAAGAAGGAGATATCGTTCCGAGTGGCACCTGTCTCGTCCACCCGTCGTC
 T P P V L D S D G S F F L Y S K L T V D K S R W Q Q G>
 431
 _____FCAC1 (A)_____>

1370 1380 1390 1400 1410 1420 1430 1440
 GAACGCTCTCTCATGCTCCGTTGATGCATGAGGCTCTGCACAACCACTACACGCAGAAAGCCCTCTCCCTGTCTCCGGGTA
 CTTGCAGAAAGTACGAGGCACACCTACTCCGAGACGTGTTGGTGTGATGTGGCTCTCTCCGAGAGGGGACAGAGGCCCAT
 N V F S C S V M H E A L H N H Y T Q K S L S L S P G>
 457
 _____FCAC1 (A)_____>

>NotI_site
 |
 1450
 AATGAGCGGCGGC
 TTAATGCGCGCGG
 K *->
 458
 _____>

Fig.22A.

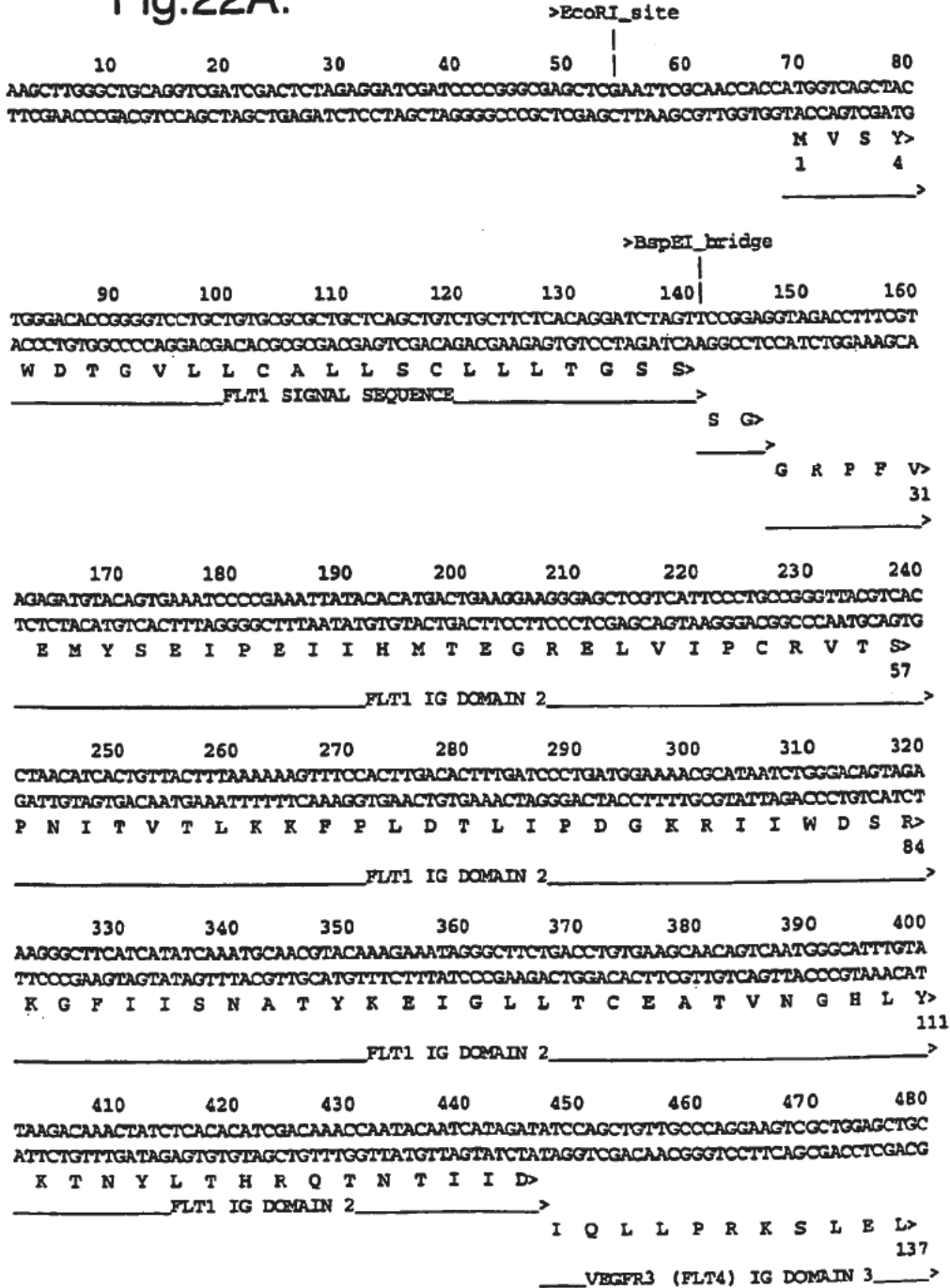

Fig.22B.

490 500 510 520 530 540 550 560
 TGGTAGGGGAGAAGCTGGTCCCAACTGCACCGTGTGGGCTGAGTTTAACTCAGGTGTCACCTTTGACTGGGACTACCCA
 ACCATCCCCTCTTCGACCAGGAGTTGACGTGGCACACCCGACTCAAATTTGAGTCCACAGTGGAAACTGACCCCTGATGGGT
 L V G E K L V L N C T V W A E F N S G V T F D W D Y P>
 164
 _____VEGFR3 (FLT4) IG DOMAIN 3_____>

570 580 590 600 610 620 630 640
 GGGAGCAGGCAGAGCGGGTAAGTGGGTGCCCGAGCGAGCTCCCAACAGACCCACACAGAACTCTCCAGCATCCTGAC
 CCTTTCGTCCTCGCCCATTCACCCACGGGCTCGCTGCGAGGGTTGCTGGGTGTGCTTTGAGAGGTCGTAGGACTG
 G K Q A E R G K W V P E R R S Q Q T H T E L S S I L T>
 191
 _____VEGFR3 (FLT4) IG DOMAIN 3_____>

650 660 670 680 690 700 710 720
 CATCCACAAGCTCAGCCAGCACGACCTGGGCTCGTATGTGTGCAAGGCCAACACCGCATCCAGCGATTTCCGGGAGAGCA
 GTAGGTGTGCAAGTGGTGGTGGACCCGAGCATAACACAGTTCCCGTTGTTGCGGTAGGTCGCTAAAGCCCTCTCGT
 I H N V S Q H D L G S Y V C K A N N G I Q R F R E S>
 217
 _____VEGFR3 (FLT4) IG DOMAIN 3_____>

730 740 750 760 770 780 790 800
 CCGAGGTCAATGTGCATGAAAATGGCCCGGGCGACAAAACCTCACACATGCCACCGTGGCCAGCACCTGAATCCTGGGG
 GGCTCCAGTAACAGTACTTTTACCGGGCCCGCTGTTTGTAGTGTGTACGGGTGGCACGGGTGGTGGACTTGAGGACCCC
 T E V I V H E N>
 _____VEGFR3 (FLT4) IG_____>
 G P G>
 _____>
 D K T H T C P P C P A P E L L G>
 244
 _____FCAC1 - A ALLOTYP_____>

810 820 830 840 850 860 870 880
 GGACCGTCAGTCTTCCTTCCOCCAAAACCCAAGGACACCCCTCATGATCTCCCGGACCCCTGAGGTACATGCGTGGT
 CCTGGCAGTCAGAAAGGAGAAGGGGGTTTGGGTCCCTGTGGGAGTACTAGAGGGCCCTGGGGACTCCAGTGTACCGACCA
 G P S V F L F P P K P K D T L M I S R T P E V T C V V>
 271
 _____FCAC1 - A ALLOTYP_____>

890 900 910 920 930 940 950 960
 GGTGGACGTGAGCCACGAAGACCCCTGAGGTCAAGTCAACTGGTACGTGGACGGCGTGGAGGTGCATAATGCCAAGACAA
 CCACCTGCACTGGTGTCTTCTGGGACTCCAGTTCAGTTGACCATGCACCTGCCGCACCTCCACGTATACCGTTCTGTT
 V D V S H E D P E V K F N W Y V D G V E V H N A K T>
 297
 _____FCAC1 - A ALLOTYP_____>

970 980 990 1000 1010 1020 1030 1040
 AGCCCGGGGAGGAGCAGTACAACAGCACTACCGTGTGGTTCAGCGTCCCTCACCGTCCCTGCACCAGGACTGGCTGAATGGC
 TGGCGCCCTCTCTGTCATGTTGTGTGTCATGGCACACCAAGTGGCAGGAGTGGCAGGACGTGGTCTGACCGACTTACCG
 K P R E E Q Y N S T Y R V V S V L T V L H Q D W L N G>
 324
 _____FCAC1 - A ALLOTYP_____>

Fig.22C.

1050 1060 1070 1080 1090 1100 1110 1120
 AAGGAGTACAAAGTGAAGGTCTCCAACAAAGCCCTCCCAGCCCCCATCGAGAAAACCATCTCCAAGCCAAAGGGCAGCC
 TTCCTCATGTTACAGTTCAGAGGTTGTTTCGGGAGGGTCGGGGTAGCTCTTTTGGTAGAGGTTTCGGTTTCCCCTCGG
 K E Y K C K V S N K A L P A P I E K T I S K A K G Q P>
 351
 _____FCAC1 - A ALLOTYPE_____>

>A>C_A_allotype
 |
 >G>T_A_allotype
 | |
 1130 1140 1150 1160 1170 1180 1190 1200
 CCGASAACCACAGGTGTACACCCCTGCCCCATCCCGGGATGAGCTGAACCAAGAACCAGGTCAGCCTGACCTGCTGGTCA
 GGCTCTTGGTGTCCACATGTGGGACGGGGTAGGGCCCTACTCGACTGGTTCCTTGGTCCAGTCGGACTGGACGGACCACT
 R E P Q V Y T L P P S R D E L T K N Q V S L T C L V>
 377
 _____FCAC1 - A ALLOTYPE_____>

1210 1220 1230 1240 1250 1260 1270 1280
 AAGGCTTCTATCCCAGCGACATGCGCGTGGAGTGGGAGAGCAATGGGCAGCCGGAGAACACTACAAGACCAAGCCCTCCC
 TTCGAAGATAGGGTGCCTGTAGCGGCACCTCACCCCTCTCGTTACCCGTCGGCCTCTTGTGATGTTCTGGTGGGAGGG
 K G F Y P S D I A V E W E S N G Q P E N N Y K T T P P>
 404
 _____FCAC1 - A ALLOTYPE_____>

>T>C
 |
 1290 1300 1310 1320 1330 1340 1350 1360
 GTGCTGGACTCCGACGGCTCCTTCTTCTCTATAGCAAGCTCACCCGTGGACAAGAGCAGGTTGGCAGCAGGGGAACGTCTT
 CACGACCTGAGGCTGCCGAGGAAGAAGGAGATATCGTTCGAGTGGCACCTGTTCCTGTCACCCGTCGTCGCCCTTGCAGAA
 V L D S D G S F F L Y S K L T V D K S R W Q Q G N V F>
 431
 _____FCAC1 - A ALLOTYPE_____>

>NotI_site
 |
 1370 1380 1390 1400 1410 1420 1430 1440
 CTCATGCTCCGTGATGCATGAGGCTCTGCACAACCACTACACGCAGAGAGCCCTCTCCCTGTCTCCGGGTAAATGAGCGG
 GAGTACGAGGCACTACGTACTCCGAGACGTGTGGTGTATGTCCGTCTTCTCGGAGAGGGACAGAGGCCCAATTACTCGCC
 S C S V M H E A L H N H Y T Q K S L S L S P G K ">
 455
 _____FCAC1 - A ALLOTYPE_____>

CCGC
GGCG

Fig.23.

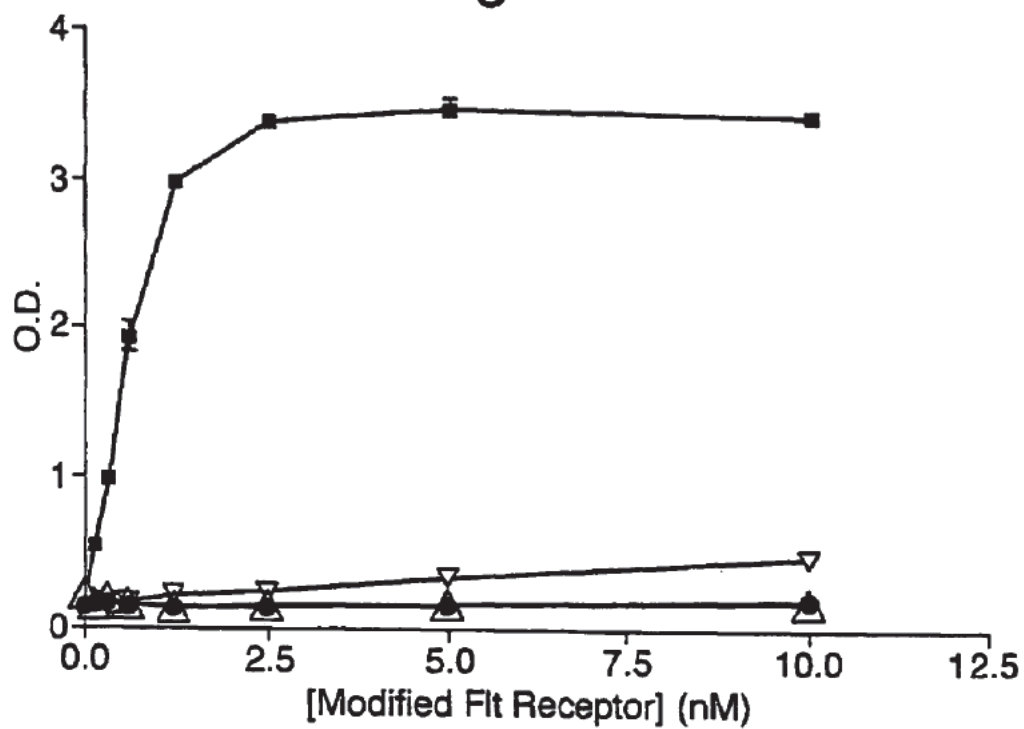

- Flt1D2Flk1D3.FcdeltaC1(a)
- △ Flt1D2VEGFR3D3.FcdeltaC1(a)
- ▽ TIE2-Fc
- Flt1(1-3)-Fc

Fig.24A.

```

      10          20          30          40          50          60
      *          *          *          *          *          *
ATG GTC AGC TAC TGG GAC ACC GGG GTC CTG CTG TGC GCG CTG CTC AGC TGT CTG CTT CTC
TAC CAG TCG ATG ACC CTG TGG CCC CAG GAC GAC ACG CGC GAC GAG TCG ACA GAC GAA GAG
M V S Y W D T G V L L C A L L S C L L L>
1_____5_____hFLTL1 SIGNAL SEQUENCE_____15_____20>

      70          80          90          100         110         120
      *          *          *          *          *          *
ACA GGA TCT AGT TCC GGA AGT GAT ACC GGT AGA CCT TTC GTA GAG ATG TAC AGT GAA ATC
TGT CCT AGA TCA AGG CCT TCA CTA TGG OCA TCT GGA AAG CAT CTC TAC ATG TCA CTT TAG
T G S S S G>
21_hFLTL1 SIGNAL SEQ_26>
      S D T G R P P V E M Y S E I>
      27_____30_____hFLTL1 IG DOMAIN 2_____40>

      130         140         150         160         170         180
      *          *          *          *          *          *
CCC GAA ATT ATA CAC ATG ACT GAA GGA AGG GAG CTC GTC ATT CCC TGC CCG GTT ACG TCA
GGG CTT TAA TAT GTG TAC TGA CTT CCT TCC CTC GAG CAG TAA GGG ACG GCC CAA TGC AGT
P E I I H M T E G R E L V I P C R V T S>
41_____45_____hFLTL1 IG DOMAIN 2_____55_____60>

      190         200         210         220         230         240
      *          *          *          *          *          *
CCT AAC ATC ACT GTT ACT TTA AAA AAG TTT CCA CTT GAC ACT TTG ATC CCT GAT GGA AAA
GGA TTG TAG TGA CAA TGA AAT TTT TTC AAA GGT GAA CTG TGA AAC TAG GGA CTA CCT TTT
P N I T V T L K K F P L D T L I P D G K>
61_____65_____hFLTL1 IG DOMAIN 2_____75_____80>

      250         260         270         280         290         300
      *          *          *          *          *          *
CGC ATA ATC TGG GAC AGT AGA AAG GGC TTC ATC ATA TCA AAT GCA ACG TAC AAA GAA ATA
GGG TAT TAG ACC CTG TCA TCT TTC CCG AAG TAG TAT AGT TTA CGT TGC ATG TTT CTT TAT
R I I W D S R K G F I I S N A T Y K E I>
81_____85_____hFLTL1 IG DOMAIN 2_____95_____100>

      310         320         330         340         350         360
      *          *          *          *          *          *
GGG CTT CTG ACC TGT GAA GCA ACA GTC AAT GGG CAT TTG TAT AAG ACA AAC TAT CTC ACA
CCC GAA GAC TGG ACA CTT CGT TGT CAG TTA CCC GTA AAC ATA TTC TGT TTG ATA GAG TGT
G L L T C E A T V N G H L Y K T N Y L T>
101_____105_____hFLTL1 IG DOMAIN 2_____115_____120>

      370         380         390         400         410         420
      *          *          *          *          *          *
CAT CGA CAA ACC AAT ACA ATC ATA GAT GTG GTT CTG AGT CCG TCT CAT GGA ATT GAA CTA
GTA GCT GTT TGG TTA TGT TAG TAT CTA CAC CAA GAC TCA GGC AGA GTA CCT TAA CTT GAT
H R Q T N T I I D>
121_____hFLTL1 IG DOMAIN 2_____129>
      V V L S P S H G I E L>
130_____hFLTL1 IG DOMAIN 3_____140>

```

Fig.24B.

430 440 450 460 470 480
 * * * * * *
 TCT GTT GGA GAA AAG CTT GTC TTA AAT TGT ACA GCA AGA ACT GAA CTA AAT GTG GGG ATT
 AGA CAA OCT CTT TTC GAA CAG AAT TTA ACA TGT CGT TCT TGA CTT GAT TTA CAC CCC TAA
 S V G E K L V L N C T A R T E L N V G I >
 141_____145_____hFLK1 IG DOMAIN 3_____155_____160>

490 500 510 520 530 540
 * * * * * *
 GAC TTC AAC TGG GAA TAC OCT TCT TCG AAG CAT CAG CAT AAG AAA CTT GTA AAC CGA GAC
 CTG AAG TTG ACC CTT ATG GGA AGA AGC TTC GTA GTC GTA TTC TTT GAA CAT TTG GCT CTG
 D F N W E Y P S S K H Q H K K L V N R D >
 161_____165_____hFLK1 IG DOMAIN 3_____175_____180>

550 560 570 580 590 600
 * * * * * *
 CTA AAA ACC CAG TCT GGG AGT GAG ATG AAG AAA TTT TTG AGC ACC TTA ACT ATA GAT GGT
 GAT TTT TGG GTC AGA CCC TCA CTC TAC TTC TTT AAA AAC TCG TGG AAT TGA TAT CTA CCA
 L K T Q S G S E M K K F L S T L T I D G >
 181_____185_____hFLK1 IG DOMAIN 3_____195_____200>

610 620 630 640 650 660
 * * * * * *
 GTA ACC CGS AGT GAC CAA GGA TTG TAC ACC TGT GCA GCA TCC AGT GGG CTG ATG ACC AAG
 CAT TGG GCC TCA CTG GTT CCT AAC ATG TGG ACA CGT CGT AGG TCA CCC GAC TAC TGG TTC
 V T R S D Q G L Y T C A A S S G L M T K >
 201_____205_____hFLK1 IG DOMAIN 3_____215_____220>

670 680 690 700 710 720
 * * * * * *
 AAG AAC AGC ACA TTT GTC AGG GTC CAT GAA AAG GAC AAA ACT CAC ACA TGC CCA CCG TGC
 TTC TTG TCG TGT AAA CAG TCC CAG GTA CTT TTC CTG TTT TGA GTG TGT ACG GGT GGC ACG
 K N S T P V R V H E K >
 221_____hFLK1 IG DOMAIN 3_____231>

D K T H T C P P >
 232_____hFCAC1 A _____240>

730 740 750 760 770 780
 * * * * * *
 CCA GCA CCT GAA CTC CTG GGG GGA CCG TCA GTC TTC CTC TTC OCC CCA AAA CCC AAG GAC
 GGT CGT GGA CTT GAG GAC CCC CCT GGC AGT CAG AAG GAG AAG GGG GGT TTT GGG TTC CTG
 P A P E L L G G P S V F L F P P K P K D >
 241_____245_____hFCAC1 A _____255_____260>

790 800 810 820 830 840
 * * * * * *
 ACC CTC ATG ATC TCC CCG ACC OCT GAG GTC ACA TGC GTG GTG GTG GAC GTG AGC CAC GAA
 TGG GAG TAC TAG AGG GCC TGG GGA CTC CAG TGT ACG CAC CAC CAC CTG CAC TCG GTG CTT
 T L M I S R T P E V T C V V V D V S H E >
 261_____265_____hFCAC1 A _____275_____280>

850 860 870 880 890 900
 * * * * * *
 GAC OCT GAG GTC AAG TTC AAC TGG TAC GTG GAC GGC GTG GAG GTG CAT AAT GCC AAG ACA
 CTG GGA CTC CAG TTC AAG TTG ACC ATG CAC CTG CCG CAC CTC CAC GTA TTA OGG TTC TGT
 D P E V K F N W Y V D G V E V H N A K T >
 281_____285_____hFCAC1 A _____295_____300>

Fig.24C.

```

          910          920          930          940          950          960
          *           *           *           *           *           *
AAG CCG CGG GAG GAG CAG TAC AAC AGC ACG TAC CGT GTG GTC AGC GTC CTC ACC GTC CTG
TTC GGC GGC CTC CTC GTC ATG TTG TCG TGC ATG GCA CAC CAG TCG CAG GAG TGG CAG GAC
K P R E E Q Y N S T Y R V V S V L T V L>
301_____305_____hFCAC1 A _____315_____320>

          970          980          990          1000         1010         1020
          *           *           *           *           *           *
CAC CAG GAC TGG CTG AAT GGC AAG GAG TAC AAG TGC AAG GTC TOC AAC AAA GCC CTC CCA
GTG GTC CTG ACC GAC TTA CCG TTC CTC ATG TTC ACG TTC CAG AGG TTG TTT CCG GAG GGT
H Q D W L N G K E Y K C K V S N K A L P>
321_____325_____hFCAC1 A _____335_____340>

          1030         1040         1050         1060         1070         1080
          *           *           *           *           *           *
GCC CCC ATC GAG AAA ACC ATC TOC AAA GCC AAA GGG CAG CCC CGA GAA CCA CAG GTG TAC
CCG GGG TAG CTC TTT TGG TAG AGG TTT CCG TTT CCG GTC GGG GCT CTT GGT GTC CAC ATG
A P I E K T I S K A K G Q P R E P Q V Y>
341_____345_____hFCAC1 A _____355_____360>

          1090         1100         1110         1120         1130         1140
          *           *           *           *           *           *
ACC CTG CCC CCA TOC CCG GAT GAG CTG ACC AAG AAC CAG GTC AGC CTG ACC TGC CTG GTC
TGG GAC GGG GGT AGG GCC CTA CTC GAC TGG TTC TTG GTC CAG TCG GAC TGG ACG GAC CAG
T L P P S R D E L T K N Q V S L T C L V>
361_____365_____hFCAC1 A _____375_____380>

          1150         1160         1170         1180         1190         1200
          *           *           *           *           *           *
AAA GGC TTC TAT CCC AGC GAC ATC GCC GTG GAG TGG GAG AGC AAT GGG CAG CCG GAG AAC
TTT CCG AAG ATA GGG TCG CTG TAG CCG CAC CTC ACC CTC TOG TTA CCC GTC GGC CTC TTG
K G F Y P S D I A V E W E S N G Q P E N>
381_____385_____hFCAC1 A _____395_____400>

          1210         1220         1230         1240         1250         1260
          *           *           *           *           *           *
AAC TAC AAG ACC ACG CCT CCC GTG CTG GAC TCC GAC GGC TOC TTC TTC CTC TAC AGC AAG
TTG ATG TTC TGG TGC GGA GGG CAC GAC CTG AGG CTG CCG AGG AAG AAG GAG ATG TCG TTC
N Y K T T P P V L D S D G S F P L Y S F>
401_____405_____hFCAC1 A _____415_____420>

          1270         1280         1290         1300         1310         1320
          *           *           *           *           *           *
CTC ACC GTG GAC AAG AGC AGG TGG CAG CAG GGG AAC GTC TTC TCA TGC TOC GTG ATG CAT
GAG TGG CAC CTG TTC TCG TOC ACC GTC GTC CCC TTG CAG AAG AGT ACG AGG CAC TAC GTA
L T V D K S R W Q Q G N V F S C S V M H>
421_____425_____hFCAC1 A _____435_____440>

          1330         1340         1350         1360         1370
          *           *           *           *           *
GAG GCT CTG CAC AAC CAC TAC ACG CAG AAG AGC CTC TOC CTG TCT CCG GGT AAA TGA
CTC CGA GAC GTG TTG GTG ATG TGC GTC TTC TCG GAG AGG GAC AGA GGC CCA TTT ACT
E A L H N H Y T Q K S L S L S P G K *>
441_____445_____hFCAC1 A _____455_____458>

```

Fig.25A.

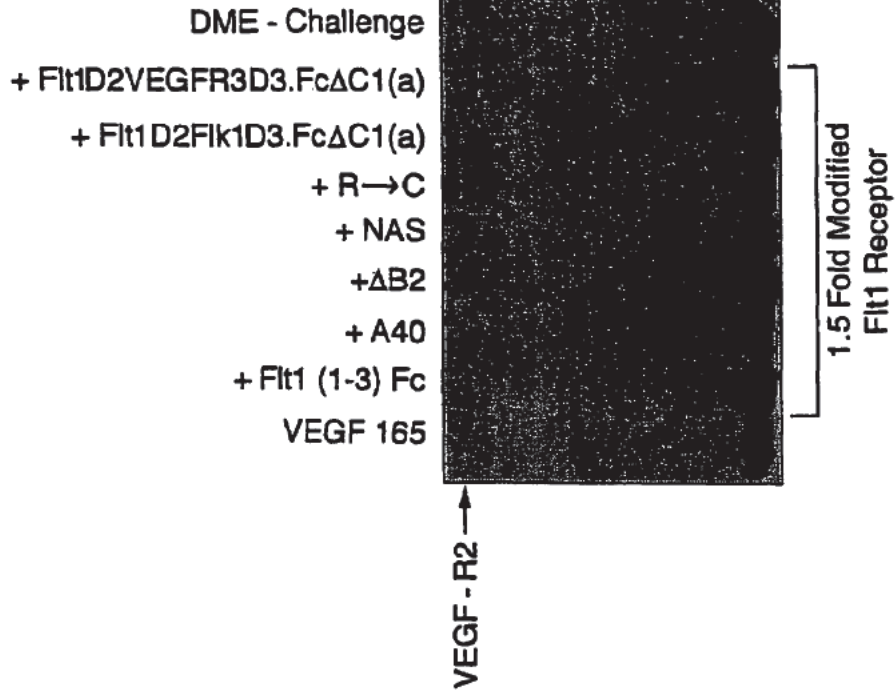

Fig.25B.

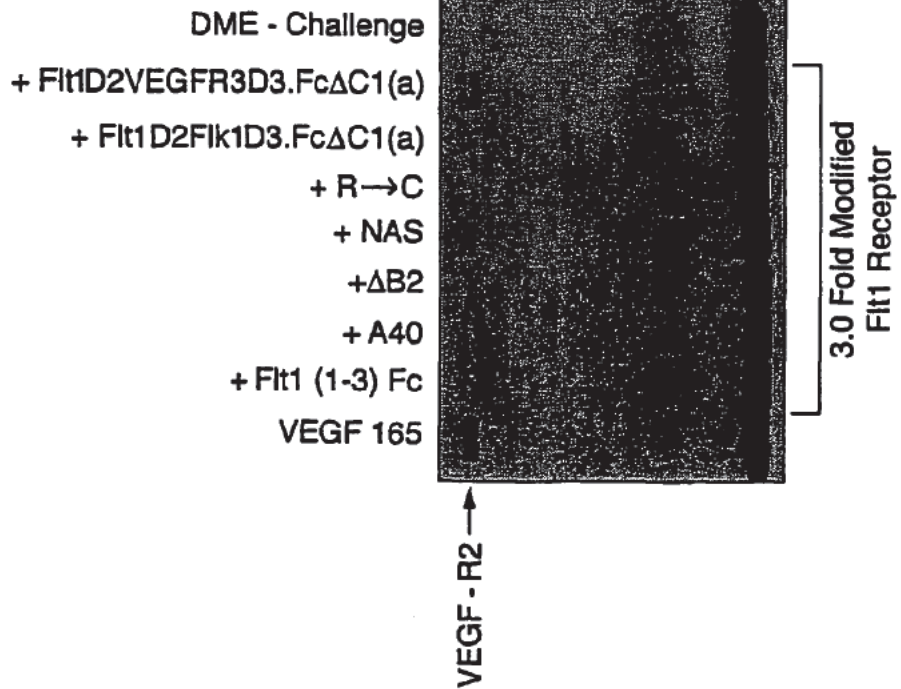

Fig.25C.

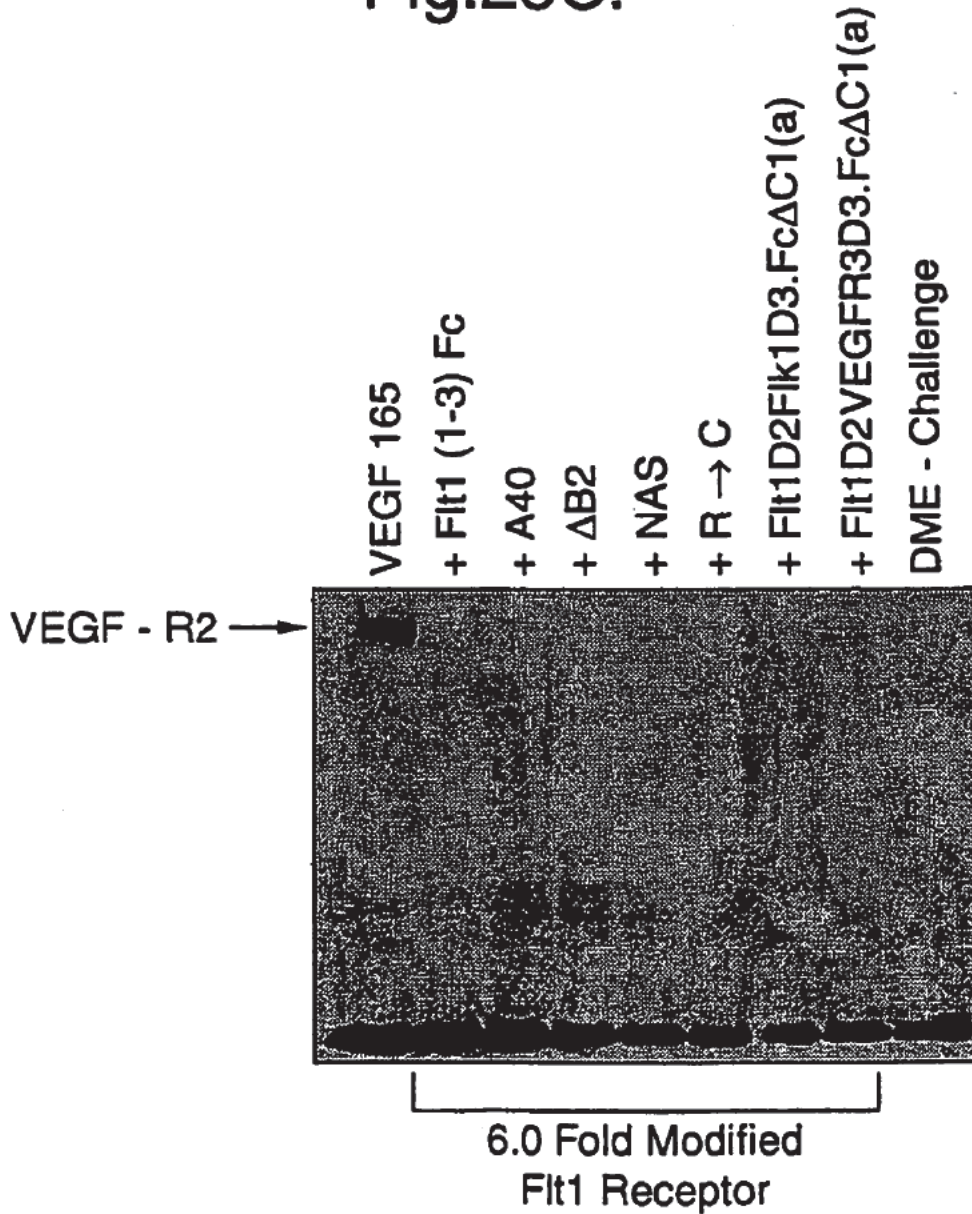

Fig.26A.

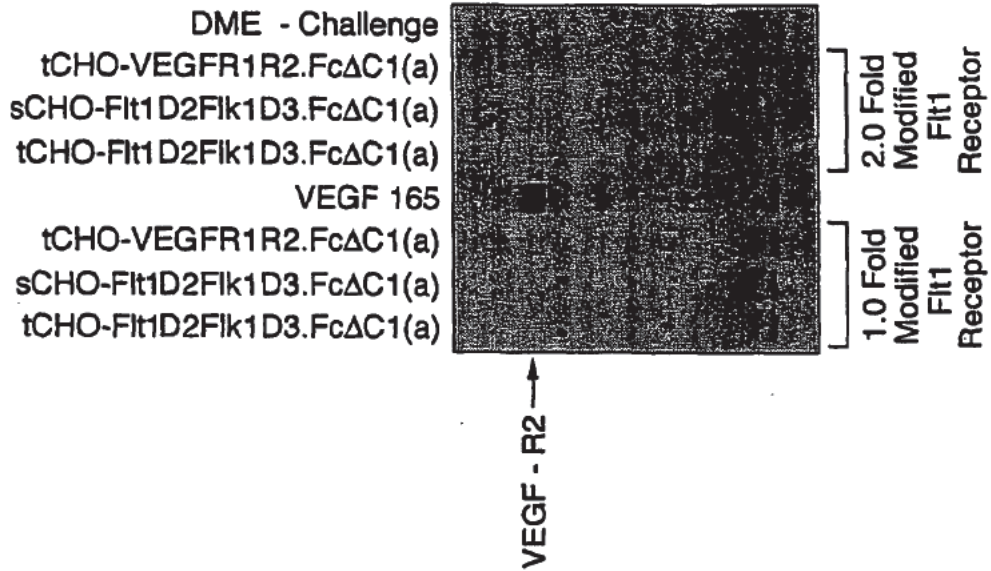

Fig.26B.

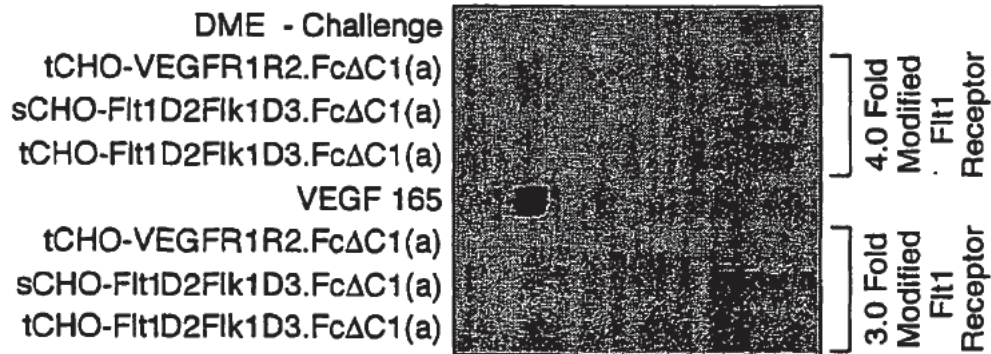

Fig.27.

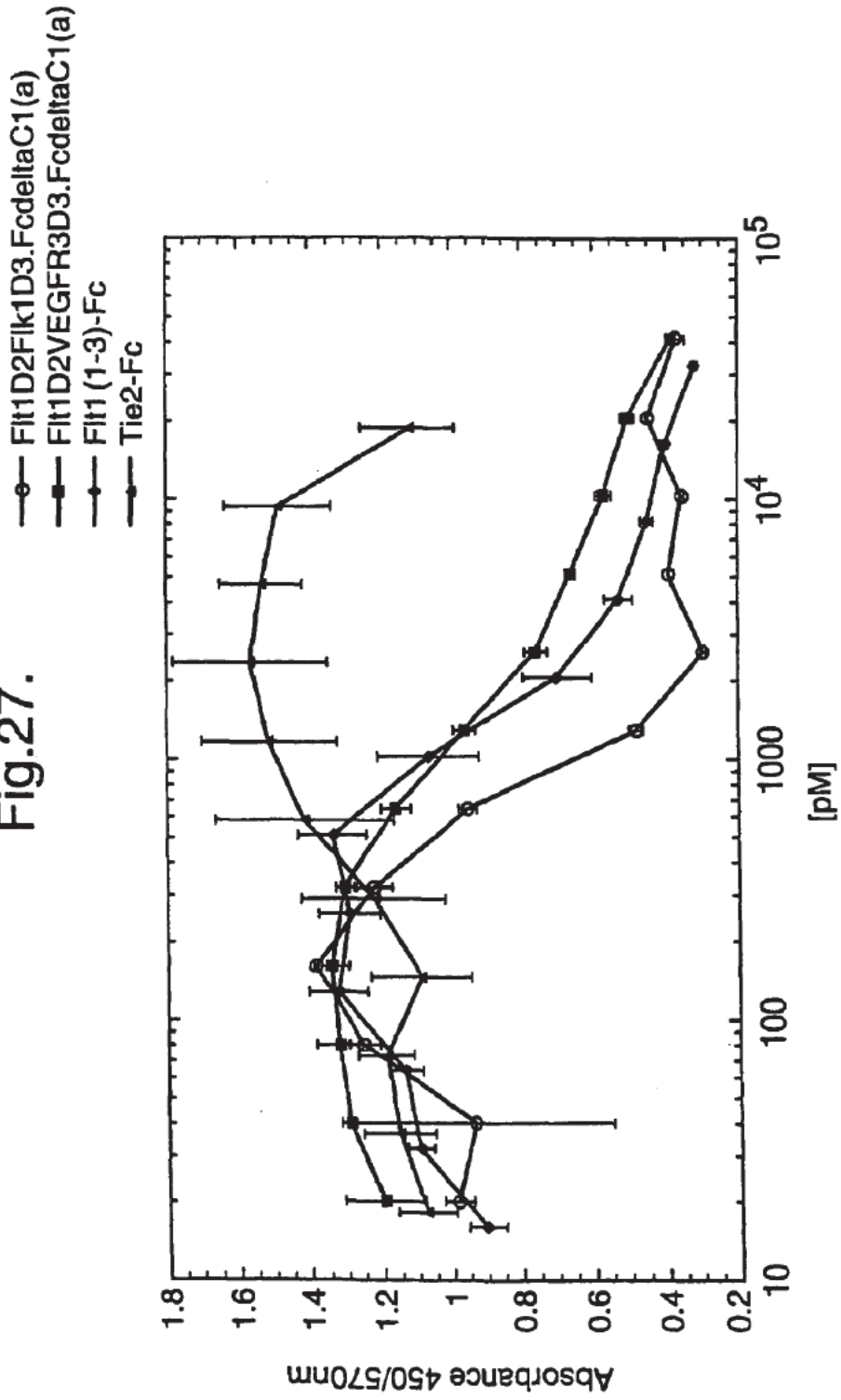

Fig.28.

Binding Stoichiometry of hVEGF165 to Fit1D2Fik1D3.FcΔC1(a) & VEGFR1R2-FcΔC1(a)		
hVEGF165 (nM)	VEGF/Fit1D2Fik1D3.FcΔC1(a)	VEGF/VEGFR1R2-FcΔC1(a)
1	0.93	0.98
10	0.97	0.94
50	1	0.99
Average ± StDev	0.96 ± 0.03	0.97 ± 0.02

Fig.29.

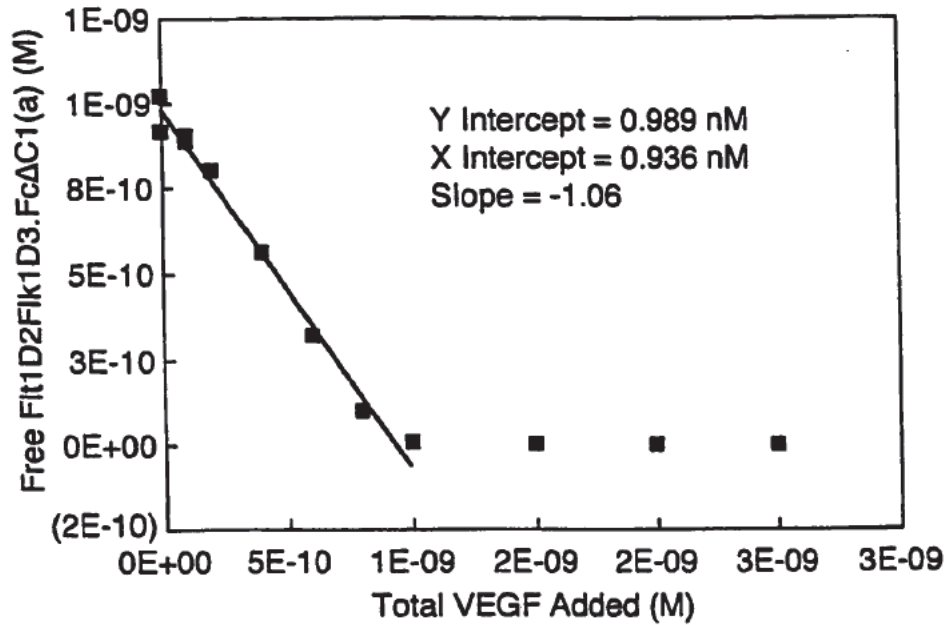

Fig.30.

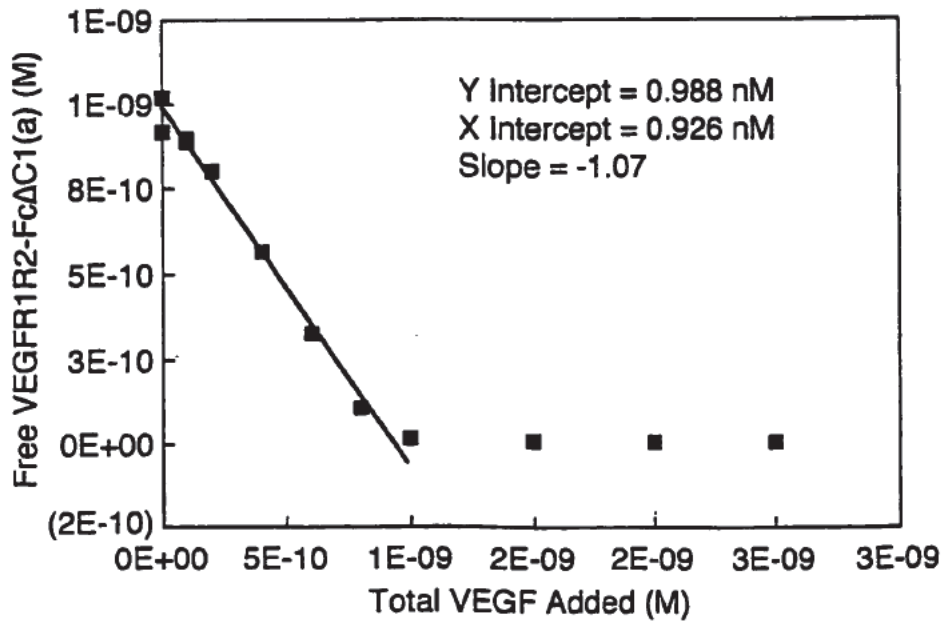

Fig.31.

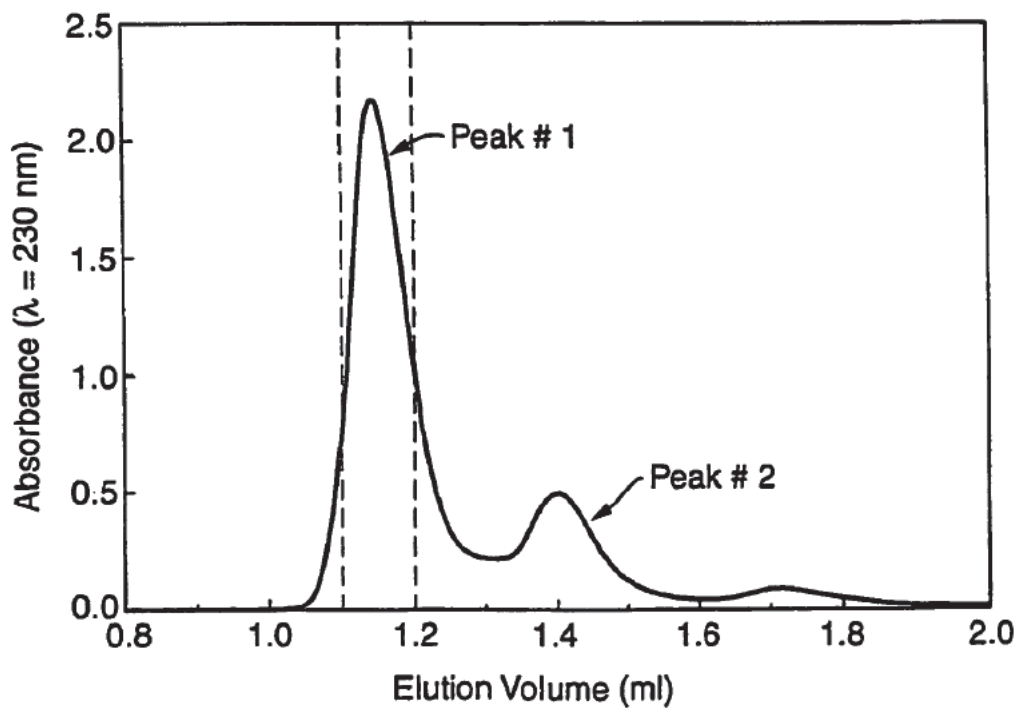

Fig.32.

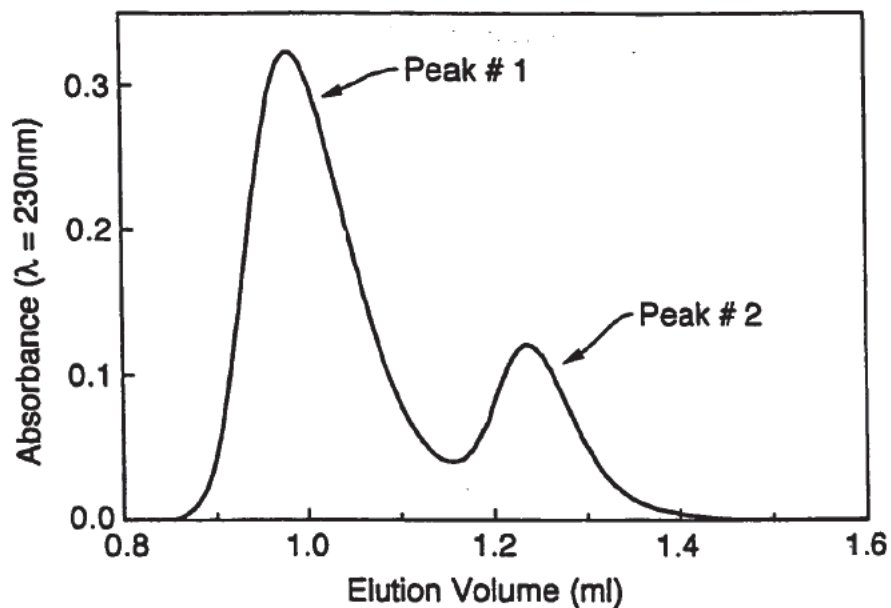

Fig.33.

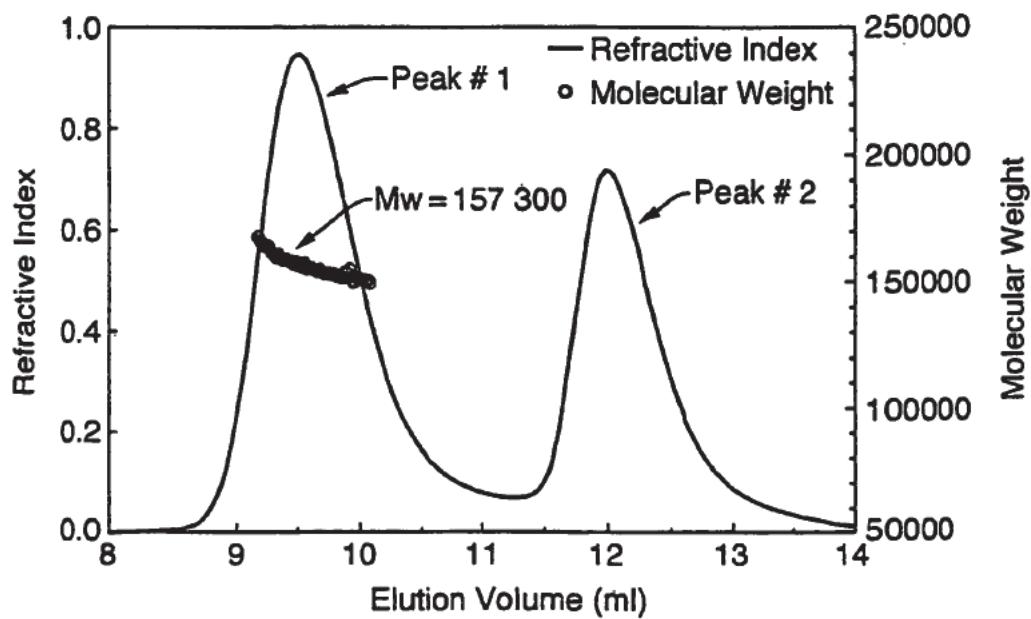

Fig.34.

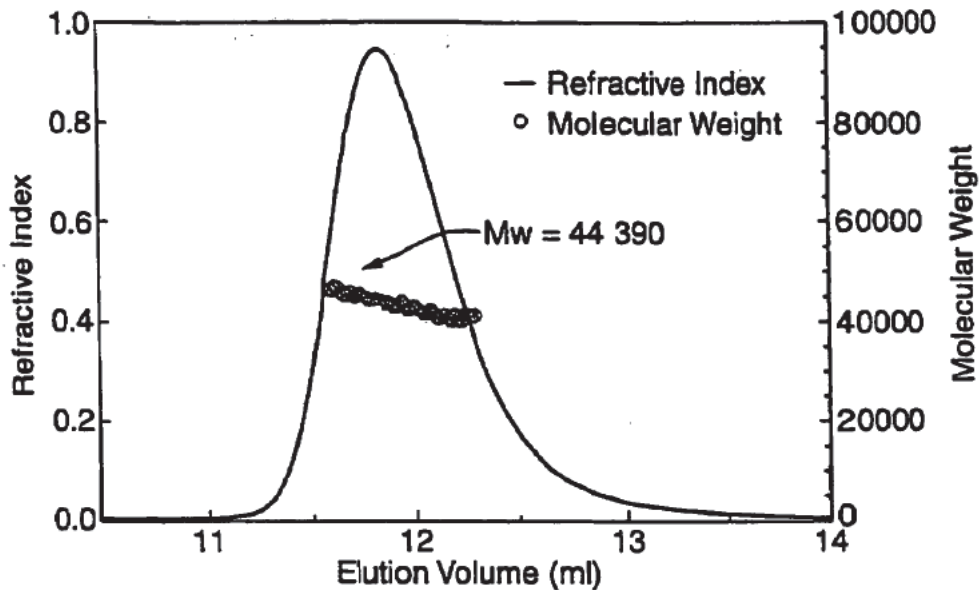

Fig.35.

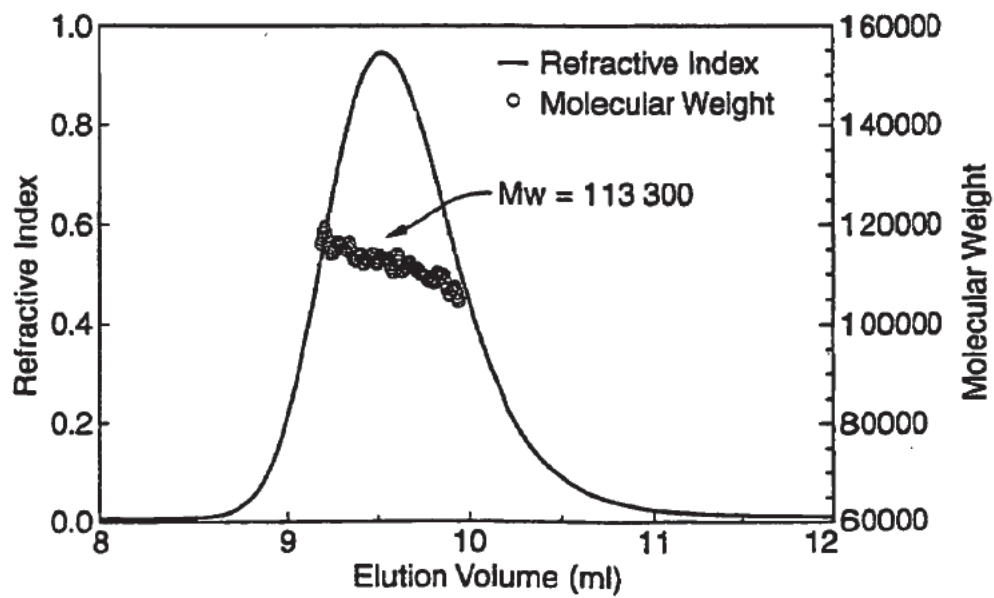

Fig.36.

50
 GRPFVEMYSEIPEIHMTEGRELVIPCRVTSPNITVTLKKFPLD¹⁰⁰TLIPDG
 KRIIWD¹⁰⁰SRKGFIIISNATYKEIGLLTCEATVNGHLYKTNYLTHRQNTIID
 150
 VVLSPSHGIELSVGEKLVLNCTARTELNVGIDFNWEYPSSKHQHKKLVNR
 200
 DLKTQSGSEMKKFLSTLTIDGVTRSDQGLYTCAASSGLMTKKNSTFVRVH
 250
 EKGPGDKTHTCPPCPAPELLGGPSVFLFPPKPKDTLMISRTPEVTCVVVD
 VSHEDPEVKFNWYVDGVEVHNAKTKPREEQYNSTYRVVSVLTVLHQDWLN³⁰⁰
 350
 GKEYKCKVSNKALPAPIEKTISKAKGQPREPQVYTLPPSRDELTKNQVSL
 400
 TCLVKGFYPSDIAVEWESNGQPENNYKTTPPVLDSDGSFFLYSKLTVDKS
 RWQQGNVFSCSVMHEALHNHYTQKSLSLSPGK

Fig.37.

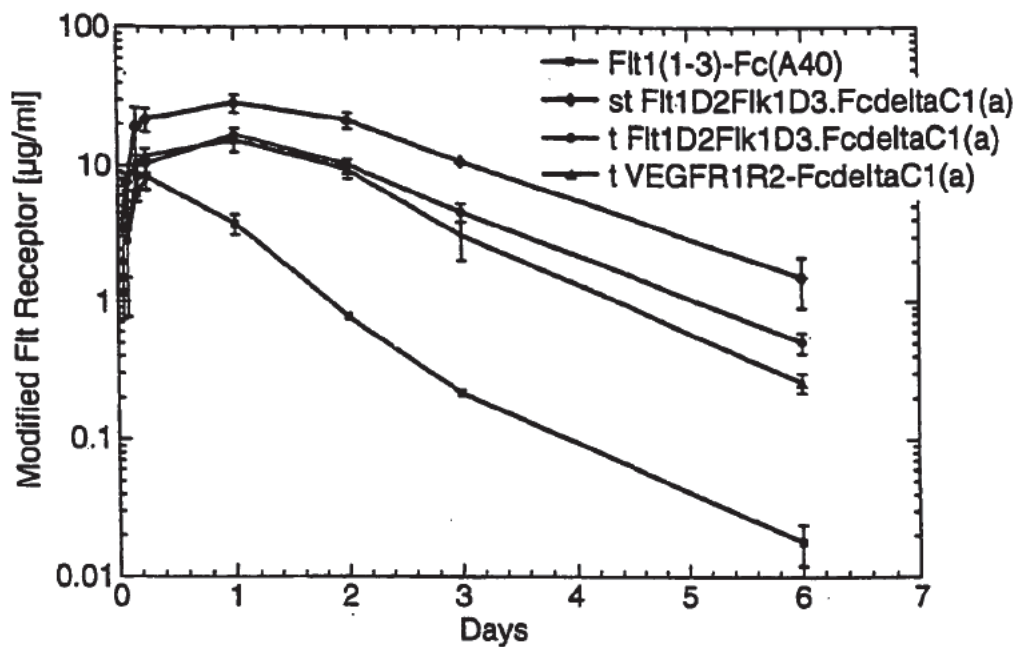
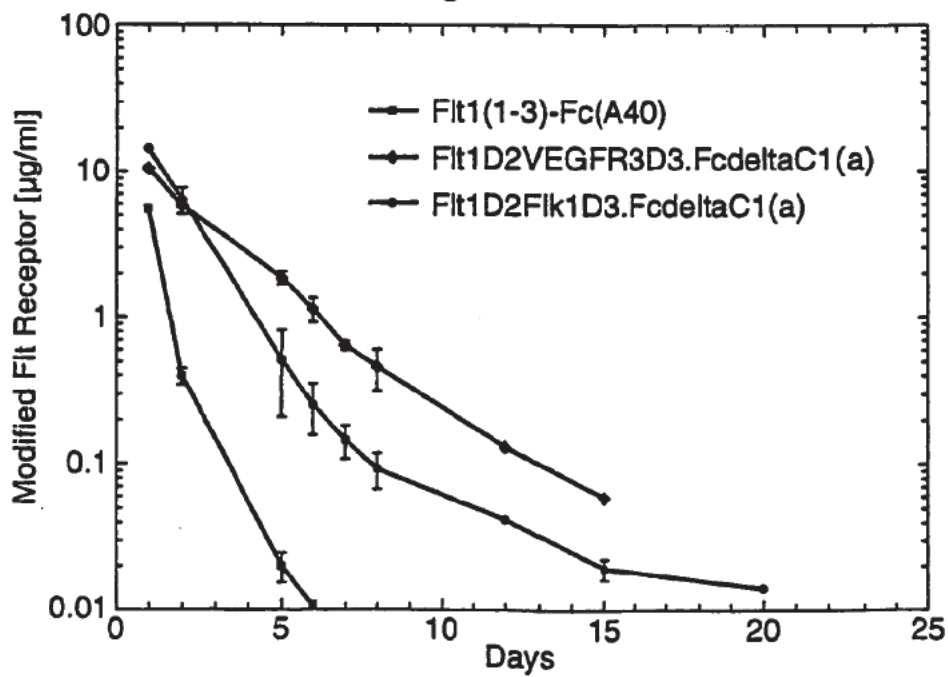

Fig.38.



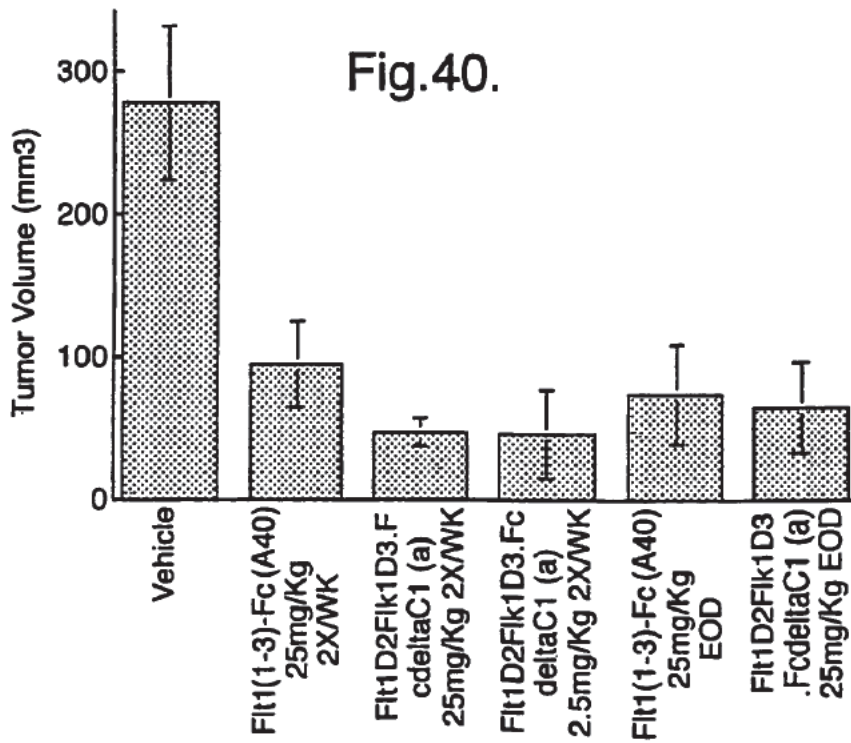
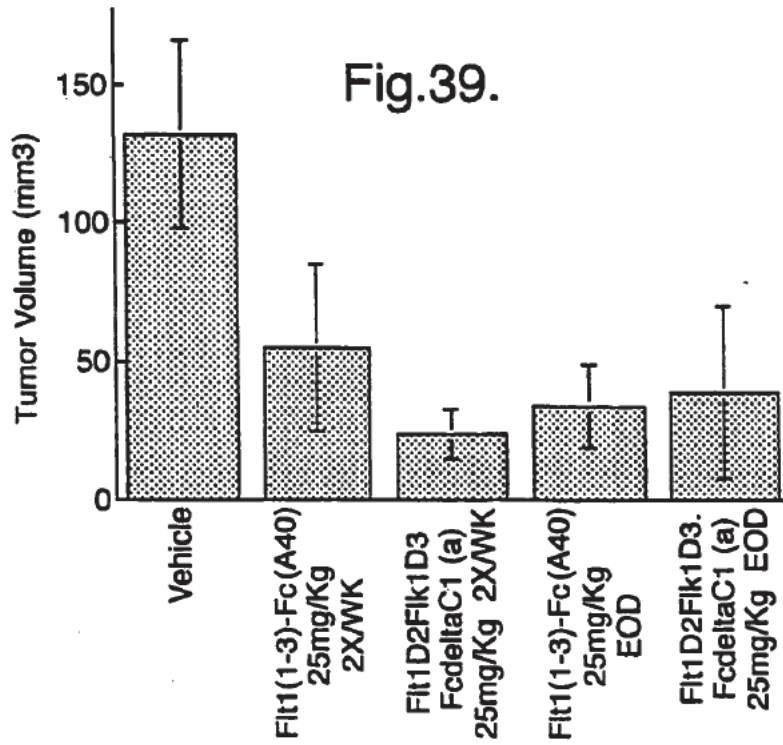

Fig.41.

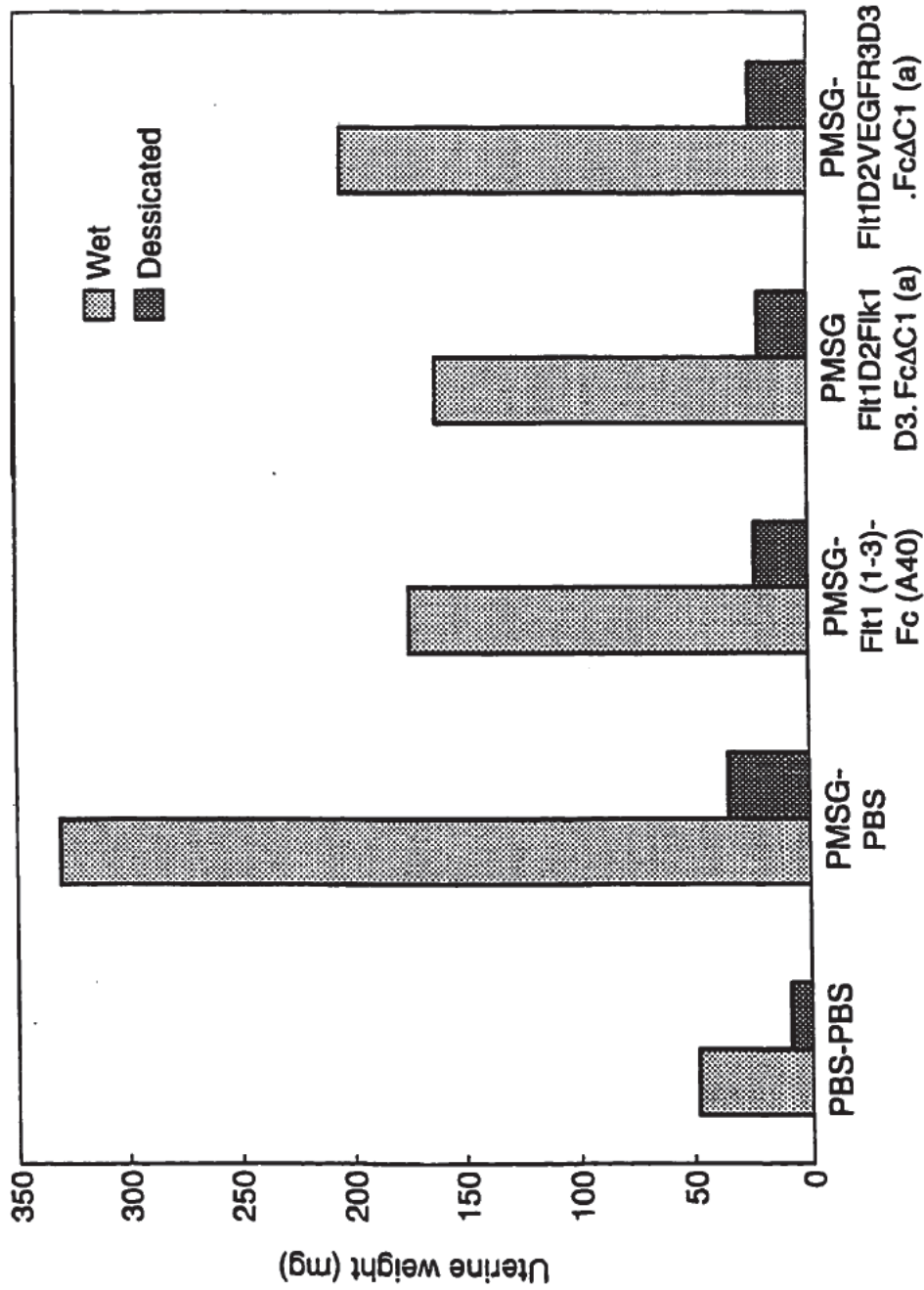

Fig.42A.

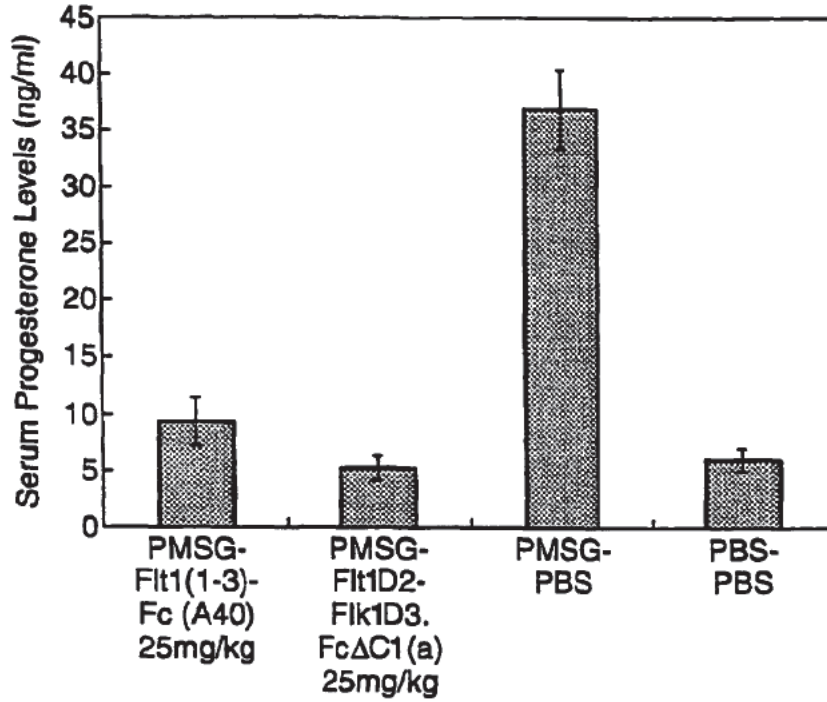
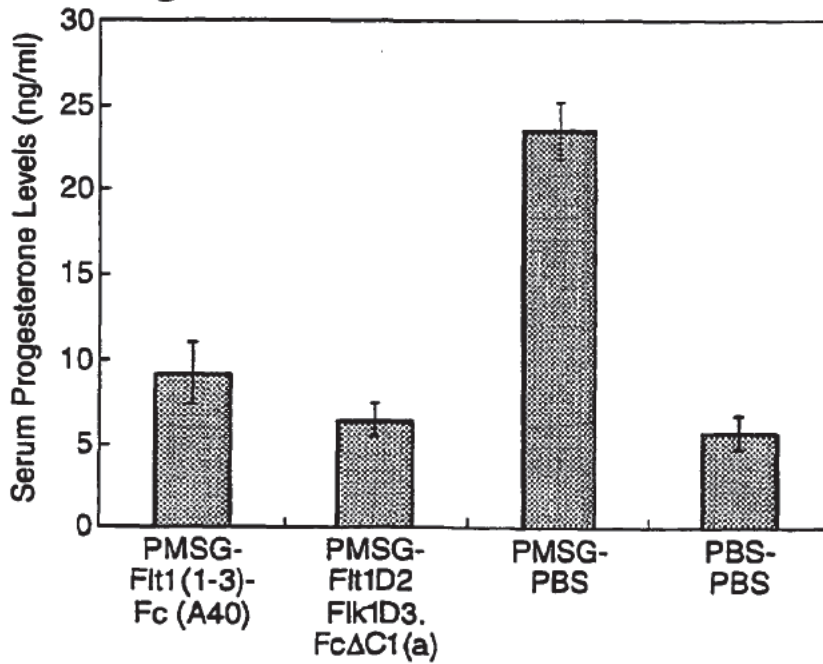

Fig.42B.



1

**MODIFIED CHIMERIC POLYPEPTIDES
WITH IMPROVED PHARMACOKINETIC
PROPERTIES AND METHODS OF USING
THEREOF**

This application is a divisional of U.S. patent application Ser. No. 10/009,852, filed Dec. 6, 2001, now U.S. Pat. No. 7,070,959, which is a national stage application of International Application No. PCT/US00/14142, filed May 23, 2000, which claims priority of U.S. Provisional Application Ser. No. 60/138,133, filed Jun. 8, 1999. The disclosures of these applications are herein specifically incorporated by reference in their entirety.

INTRODUCTION

The field of this invention is modified polypeptides with improved pharmacokinetics. Specifically, the field of this invention relates to Flt1 receptor polypeptides that have been modified in such a way as to improve their pharmacokinetic profile. The field of this invention also relates to methods of making and using the modified polypeptides including but not limited to using the modified polypeptides to decrease or inhibit plasma leakage and/or vascular permeability in a mammal.

BACKGROUND

The ability of polypeptide ligands to bind to cells and thereby elicit a phenotypic response such as cell growth, survival, cell product secretion, or differentiation is often mediated through transmembrane receptors on the cells. The extracellular domain of such receptors (i.e. that portion of the receptor that is displayed on the surface of the cell) is generally the most distinctive portion of the molecule, as it provides the protein with its ligand binding characteristic. Binding of a ligand to the extracellular domain generally results in signal transduction which transmits a biological signal to intracellular targets. Often, this signal transduction acts via a catalytic intracellular domain. The particular array of sequence motifs of this catalytic intracellular domain determines its access to potential kinase substrates (Mohammadi, et al., 1990, *Mol. Cell. Biol.* 11:5068-5078; Fantl, et al., 1992, *Cell* 69:413-413). Examples of receptors that transduce signals via catalytic intracellular domains include the receptor tyrosine kinases (RTKs) such as the Trk family of receptors which are generally limited to cells of the nervous system, the cytokine family of receptors including the tripartate CNTF receptor complex (Stahl & Yancopoulos, 1994, *J. Neurobio.* 25:1454-1466) which is also generally limited to the cells of the nervous system, G-protein coupled receptors such as the β_2 -adrenergic receptor found on, for instance, cardiac muscle cells, and the multimeric IgE high affinity receptor Fc ϵ RI which is localized, for the most part, on mast cells and basophils (Sutton & Gould, 1993, *Nature* 366:421-428).

All receptors identified so far appear to undergo dimerization, multimerization, or some related conformational change following ligand binding (Schlessinger, J., 1988, *Trend Biochem. Sci.* 13:443-447; Ullrich & Schlessinger, 1990, *Cell* 61:203-212; Schlessinger & Ullrich, 1992, *Neuron* 9:383-391) and molecular interactions between dimerizing intracellular domains lead to activation of catalytic function. In some instances, such as platelet-derived growth factor (PDGF), the ligand is a dimer that binds two receptor molecules (Hart, et al., 1988, *Science*, 240:1529-1531; Heldin, 1989, *J. Biol. Chem.* 264:8905-8912) while, for

2

example, in the case of epidermal growth factor (EGF), the ligand is a monomer (Weber, et al., 1984, *J. Biol. Chem.* 259:14631-14636). In the case of the Fc ϵ RI receptor, the ligand, IgE, exists bound to Fc ϵ RI in a monomeric fashion and only becomes activated when antigen binds to the IgE/Fc ϵ RI complex and cross-links adjacent IgE molecules (Sutton & Gould, 1993, *Nature* 366:421-428).

Often, the tissue distribution of a particular receptor within higher organisms provides insight into the biological function of the receptor. The RTKs for some growth and differentiation factors, such as fibroblast growth factor (FGF), are widely expressed and therefore appear to play some general role in tissue growth and maintenance. Members of the Trk RTK family (Glass & Yancopoulos, 1993, *Trends in Cell Biol.* 3:262-268) of receptors are more generally limited to cells of the nervous system, and the Nerve Growth Factor family consisting of nerve growth factor (NGF), brain-derived neurotrophic factor (BDNF), neurotrophin-3 (NT-3) and neurotrophin-4/5 (NT-4/5), which bind the Trk RTK family receptors, promote the differentiation of diverse groups of neurons in the brain and periphery (Lindsay, R. M., 1993, in *Neurotrophic Factors*, S. E. Loughlin & J. H. Fallon, eds., pp. 257-284, San Diego, Calif., Academic Press). Fc ϵ RI is localized to a very limited number of types of cells such as mast cells and basophils. Mast cells derive from bone marrow pluripotent hematopoietic stem cell lineage, but complete their maturation in the tissue following migration from the blood stream (See Janeway & Travers, 1996, in *Immunobiology*, 2d. Edition, M. Robertson & E. Lawrence, eds., pp. 1:3-1:4, Current Biology Ltd., London, UK, Publisher) and are involved in the allergic response.

Many studies have demonstrated that the extracellular domain of a receptor provides the specific ligand binding characteristic. Furthermore, the cellular environment in which a receptor is expressed may influence the biological response exhibited upon binding of a ligand to the receptor. For example, when a neuronal cell expressing a Trk receptor is exposed to a neurotrophin which binds to that receptor, neuronal survival and differentiation results. When the same receptor is expressed by a fibroblast, exposure to the neurotrophin results in proliferation of the fibroblast (Glass, et al., 1991, *Cell* 66:405-413).

A class of cell-derived dimeric mitogens with selectivity for vascular endothelial cells has been identified and designated vascular endothelial cell growth factor (VEGF). VEGF has been purified from conditioned growth media of rat glioma cells [Conn et al., (1990), *Proc. Natl. Acad. Sci. U.S.A.*, 87, pp 2628-2632]; and conditioned growth media of bovine pituitary follicle stellate cells [Ferrara and Henzel, (1989), *Biochem. Biophys. Res. Commun.*, 161, pp. 851-858; Gozpadarowicz et al., (1989), *Proc. Natl. Acad. Sci. U.S.A.*, 86, pp. 7311-7315] and conditioned growth medium from human U937 cells [Connolly, D. T. et al. (1989), *Science*, 246, pp. 1309-1312]. VEGF is a dimer with an apparent molecular mass of about 46 kDa with each subunit having an apparent molecular mass of about 23 kDa. VEGF has some structural similarities to platelet derived growth factor (PDGF), which is a mitogen for connective tissue cells but not mitogenic for vascular endothelial cells from large vessels.

The membrane-bound tyrosine kinase receptor, known as Flt, was shown to be a VEGF receptor [DeVries, C. et al., (1992), *Science*, 255, pp. 989-991]. The Flt receptor specifically binds VEGF which induces mitogenesis. Another form of the VEGF receptor, designated KDR, is also known to bind VEGF and induce mitogenesis. The partial cDNA

sequence and nearly full length protein sequence of KDR is known as well [Terman, B. I. et al., (1991) *Oncogene* 6, pp. 1677-1683; Terman, B. I. et al., (1992) *Biochem. Biophys. Res. Comm.* 187, pp. 1579-1586].

Persistent angiogenesis may cause or exacerbate certain diseases such as psoriasis, rheumatoid arthritis, hemangiomas, angiofibromas, diabetic retinopathy and neovascular glaucoma. An inhibitor of VEGF activity would be useful as a treatment for such diseases and other VEGF-induced pathological angiogenesis and vascular permeability conditions, such as tumor vascularization. The present invention relates to a VEGF inhibitor that is based on the VEGF receptor Flt1.

Plasma leakage, a key component of inflammation, occurs in a distinct subset of microvessels. In particular, in most organs plasma leakage occurs specifically in the venules. Unlike arterioles and capillaries, venules become leaky in response to numerous inflammatory mediators including histamine, bradykinin, and serotonin. One characteristic of inflammation is the plasma leakage that results from intercellular gaps that form in the endothelium of venules. Most experimental models of inflammation indicate that these intercellular gaps occur between the endothelial cells of postcapillary and collecting venules (Baluk, P., et al., *Am. J. Pathol.* 1998 152:1463-76). It has been shown that certain lectins may be used to reveal features of focal sites of plasma leakage, endothelial gaps, and finger-like processes at endothelial cell borders in inflamed venules (Thurston, G., et al., *Am. J.*

Physiol. 1996, 271: H2547-62). In particular, plant lectins have been used to visualize morphological changes at endothelial cell borders in inflamed venules of, for example, the rat trachea. Lectins, such as concanavalin A and ricin, that bind focally to inflamed venules reveal regions of the subendothelial vessel wall exposed by gaps that correspond to sites of plasma leakage (Thurston, G., et al., *Am J Physiol*, 1996, 271: H2547-62).

The properties of the microvessels are dynamic. Chronic inflammatory diseases, for example, are associated with microvascular remodeling, including angiogenesis and microvessel enlargement. Microvessels can also remodel by acquiring abnormal phenotypic properties. In a murine model of chronic airway inflammation, airway capillaries acquire properties of venules, including widened vessel diameter, increased immunoreactivity for von Willebrand factor, and increased immunoreactivity for P-selectin. In addition, these remodeled vessels leak in response to inflammatory mediators, whereas vessels in the same position in the airways of normal mice do not.

Certain substances have been shown to decrease or inhibit vascular permeability and/or plasma leakage. For example, mystixins are synthetic polypeptides that have been reported to inhibit plasma leakage without blocking endothelial gap formation (Baluk, P., et al., *J. Pharmacol. Exp. Ther.*, 1998, 284: 693-9). Also, the beta 2-adrenergic receptor agonist formoterol reduces microvascular leakage by inhibiting endothelial gap formation (Baluk, P. and McDonald, D. M., *Am. J. Physiol.*, 1994, 266:L461-8).

The angiopoietins and members of the vascular endothelial growth factor (VEGF) family are the only growth factors thought to be largely specific for vascular endothelial cells. Targeted gene inactivation studies in mice have shown that VEGF is necessary for the early stages of vascular development and that Ang-1 is required for later stages of vascular remodeling.

U.S. Pat. No. 6,011,003, issued Jan. 4, 2000, in the name of Metris Therapeutics Limited, discloses an altered, soluble

form of FLT polypeptide being capable of binding to VEGF and thereby exerting an inhibitory effect thereon, the polypeptide comprising five or fewer complete immunoglobulin domains.

U.S. Pat. No. 5,712,380, issued Jan. 27, 1998 and assigned to Merck & Co., discloses vascular endothelial cell growth factor (VEGF) inhibitors that are naturally occurring or recombinantly engineered soluble forms with or without a C-terminal transmembrane region of the receptor for VEGF.

Also assigned to Merck & Co. is PCT Publication No. WO 98/13071, published Apr. 2, 1998, which discloses gene therapy methodology for inhibition of primary tumor growth and metastasis by gene transfer of a nucleotide sequence encoding a soluble receptor protein which binds to VEGF.

PCT Publication No. WO 97/44453, published Nov. 27, 1997, in the name of Genentech, Inc., discloses novel chimeric VEGF receptor proteins comprising amino acid sequences derived from the vascular endothelial growth factor (VEGF) receptors Flt1 and KDR, including the murine homologue to the human KDR receptor FLK1, wherein said chimeric VEGF receptor proteins bind to VEGF and antagonize the endothelial cell proliferative and angiogenic activity thereof.

PCT Publication No. WO 97/13787, published Apr. 17, 1997, in the name of Toa Gosei Co., LTD., discloses a low molecular weight VEGF inhibitor usable in the treatment of diseases accompanied by neovascularization such as solid tumors. A polypeptide containing the first immunoglobulin-like domain and the second immunoglobulin-like domain in the extracellular region of a VEGF receptor FLT but not containing the sixth immunoglobulin-like domain and the seventh immunoglobulin-like domain thereof shows a VEGF inhibitory activity.

Sharifi, J. et al., 1998, *The Quarterly Jour. of Nucl. Med.* 42:242-249, disclose that because monoclonal antibodies (MAbs) are basic, positively charged proteins, and mammalian cells are negatively charged, the electrostatic interactions between the two can create higher levels of background binding resulting in low tumor to normal organ ratios. To overcome this effect, the investigators attempted to improve MAb clearance by using various methods such as secondary agents as well as chemical and charge modifications of the MAb itself.

Jensen-Pippo, et al., 1996, *Pharmaceutical Research* 13:102-107, disclose that pegylation of a therapeutic protein, recombinant human granulocyte colony stimulating factor (PEG-G-CSF), results in an increase in stability and in retention of in vivo bioactivity when administered by the intraduodenal route.

Tsutsumi, et al., 1997, *Thromb Haemost.* 77:168-73, disclose experiments wherein the in vivo thrombopoietic activity of polyethylene glycol-modified interleukin-6 (MPEG-IL-6), in which 54% of the 14 lysine amino groups of IL-6 were coupled with PEG, was compared to that of native IL-6.

Yang, et al., 1995, *Cancer* 76:687-94, disclose that conjugation of polyethylene glycol to recombinant human interleukin-2 (IL-2) results in a compound, polyethylene glycol-modified IL-2 (PEG-IL-2) that retains the in vitro and in vivo activity of IL-2, but exhibits a markedly prolonged circulating half-life.

R. Duncan and F. Spreafico, *Clin. Pharmacokinet.* 27: 290-306, 296 (1994) review efforts to improve the plasma half-life of asparaginase by conjugating polyethylene glycol.

PCT International Publication No. WO 99/03996 published Jan. 28, 1999 in the name of Regeneron Pharmaceu-

5

ticals, Inc. and The Regents of The University of California describes modified human noggin polypeptides having deletions of regions of basic amino acids. The modified human noggin polypeptides are described as retaining biological activity while having reduced affinity for heparin and superior pharmacokinetics in animal sera as compared to the unmodified human noggin.

SUMMARY OF THE INVENTION

The present invention is directed to VEGF antagonists with improved pharmacokinetic properties. A preferred embodiment is an isolated nucleic acid molecule encoding a fusion polypeptide capable of binding a VEGF polypeptide comprising (a) a nucleotide sequence encoding a VEGF receptor component operatively linked to (b) a nucleotide sequence encoding a multimerizing component, wherein the VEGF receptor component is the only VEGF receptor component of the fusion polypeptide and wherein the nucleotide sequence of (a) consists essentially of a nucleotide sequence encoding the amino acid sequence of Ig domain 2 of the extracellular domain of a first VEGF receptor and a nucleotide sequence encoding the amino acid sequence of Ig domain 3 of the extracellular domain of a second VEGF receptor.

In a further embodiment, the isolated nucleic acid of the first VEGF receptor is Flt1.

In a further embodiment, the isolated nucleic acid of the second VEGF receptor is Flt1.

In yet another embodiment, the isolated nucleic acid of the second VEGF receptor is Flt4.

In another preferred embodiment, the nucleotide sequence encoding Ig domain 2 of the extracellular domain of the first VEGF receptor is upstream of the nucleotide sequence encoding Ig domain 3 of the extracellular domain of the second VEGF receptor.

In still another preferred embodiment, the nucleotide sequence encoding Ig domain 2 of the extracellular domain of the first VEGF receptor is downstream of the nucleotide sequence encoding Ig domain 3 of the extracellular domain of the second VEGF receptor.

In a preferred embodiment of the invention, the multimerizing component comprises an immunoglobulin domain.

In another embodiment, the immunoglobulin domain is selected from the group consisting of the Fc domain of IgG, the heavy chain of IgG, and the light chain of IgG.

Preferred embodiments include an isolated nucleic acid molecule comprising a nucleotide sequence encoding a modified Flt1 receptor fusion polypeptide, wherein the coding region of the nucleic acid molecule consists of a nucleotide sequence selected from the group consisting of

- (a) the nucleotide sequence set forth in FIG. 13A-13D (SEQ ID NO:3);
- (b) the nucleotide sequence set forth in FIG. 14A-14C (SEQ ID NO:5);
- (c) the nucleotide sequence set forth in FIG. 15A-15C (SEQ ID NO:7);
- (d) the nucleotide sequence set forth in FIG. 16A-16D (SEQ ID NO:9);
- (e) the nucleotide sequence set forth in FIG. 21A-21C (SEQ ID NO:11);
- (f) the nucleotide sequence set forth in FIG. 22A-22C (SEQ ID NO:13);
- (g) the nucleotide sequence set forth in FIG. 24A-24C (SEQ ID NO:15); and
- (h) a nucleotide sequence which, as a result of the degeneracy of the genetic code, differs from the nucleotide

6

sequence of (a), (b), (c), (d), (e), (f), or (g) and which encodes a fusion polypeptide molecule having the biological activity of the modified Flt1 receptor fusion polypeptide.

In a further embodiment of the invention, a fusion polypeptide is encoded by the isolated nucleic acid molecules described above.

A preferred embodiment is a composition capable of binding a VEGF molecule to form a nonfunctional complex comprising a multimer of the fusion polypeptide.

Also preferred is a composition wherein the multimer is a dimer.

In yet another embodiment, the composition is in a carrier.

Another embodiment is a vector which comprises the nucleic acid molecules described above, including an expression vector comprising a the nucleic acid molecules described wherein the nucleic acid molecule is operatively linked to an expression control sequence.

Other included embodiments are a host-vector system for the production of a fusion polypeptide which comprises the expression vector, in a suitable host cell; the host-vector system wherein the suitable host cell is a bacterial cell, yeast cell, insect cell, or mammalian cell; the host-vector system wherein the suitable host cell is *E. Coli*; the host-vector system wherein the suitable host cell is a COS cell; the host-vector system wherein the suitable host cell is a CHO cell.

Another embodiment of the invention is a method of producing a fusion polypeptide which comprises growing cells of the host-vector system under conditions permitting production of the fusion polypeptide and recovering the fusion polypeptide so produced.

Additional embodiments include a fusion polypeptide encoded by the nucleic acid sequence set forth in FIG. 10A-10D (SEQ ID NO:1) or FIG. 24A-24C (SEQ ID NO:15), which has been modified by acetylation or pegylation wherein the acetylation is accomplished with at least about a 100 fold molar excess of acetylation reagent or wherein acetylation is accomplished with a molar excess of acetylation reagent ranging from at least about a 10 fold molar excess to about a 100 fold molar excess or wherein the pegylation is 10K or 20K PEG.

A preferred embodiment includes a method of decreasing or inhibiting plasma leakage in a mammal comprising administering to the mammal the fusion polypeptide described above, including embodiments wherein the mammal is a human, the fusion polypeptide is acetylated or the fusion polypeptide is pegylated.

A further embodiment is a fusion polypeptide which specifically binds the VEGF receptor ligand VEGF.

A preferred embodiment of the invention is a method of blocking blood vessel growth in a human comprising administering an effective amount of the fusion polypeptide described above.

Also preferred is a method of inhibiting VEGF receptor ligand activity in a mammal comprising administering to the mammal an effective amount of the fusion polypeptide described above.

Preferred embodiments of these methods are wherein the mammal is a human.

Further embodiments of the methods of the invention include attenuation or prevention of tumor growth in a human; attenuation or prevention of edema in a human, especially wherein the edema is brain edema; attenuation or prevention of ascites formation in a human, especially wherein the ascites is ovarian cancer-associated ascites.

Preferred embodiments of the invention include a fusion polypeptide capable of binding a VEGF polypeptide comprising (a) a VEGF receptor component operatively linked to (b) a multimerizing component, wherein the VEGF receptor component is the only VEGF receptor component in the fusion polypeptide and consists essentially of the amino acid sequence of Ig domain 2 of the extracellular domain of a first VEGF receptor and the amino acid sequence of Ig domain 3 of the extracellular domain of a second VEGF receptor.

In a further embodiment of the fusion polypeptide, the first VEGF receptor is Flt1.

In yet a further embodiment of the fusion polypeptide, the second VEGF receptor is Flk1.

Still another embodiment of the fusion polypeptide is one in which the second VEGF receptor is Flt4.

Preferred embodiments include a fusion polypeptide wherein amino acid sequence of Ig domain 2 of the extracellular domain of the first VEGF receptor is upstream of the amino acid sequence of Ig domain 3 of the extracellular domain of the second VEGF receptor and a fusion polypeptide wherein the amino acid sequence of Ig domain 2 of the extracellular domain of the first VEGF receptor is downstream of the amino acid sequence of Ig domain 3 of the extracellular domain of the second VEGF receptor.

In yet another embodiment, the fusion polypeptide multimerizing component comprises an immunoglobulin domain including an embodiment wherein the immunoglobulin domain is selected from the group consisting of the Fc domain of IgG, the heavy chain of IgG, and the light chain of IgG.

Preferred embodiments include a fusion polypeptide comprising an amino acid sequence of a modified Flt1 receptor, wherein the amino acid sequence selected from the group consisting of (a) the amino acid sequence set forth in FIG. 13A-13D (SEQ ID NO:4); (b) the amino acid sequence set forth in FIG. 14A-14C (SEQ ID NO:6); (c) the amino acid sequence set forth in FIG. 15A-15C (SEQ ID NO:8); (d) the amino acid sequence set forth in FIG. 16A-16D (SEQ ID NO:10); (e) the amino acid sequence set forth in FIG. 21A-21C (SEQ ID NO:12); (f) the amino acid sequence set forth in FIG. 22A-22C (SEQ ID NO:14); and (g) the amino acid sequence set forth in FIG. 24A-24C (SEQ ID NO:16).

Another preferred embodiment is a method of decreasing or inhibiting plasma leakage in a mammal comprising administering to the mammal the fusion polypeptide described above.

An alternative preferred embodiment is a method of inhibiting VEGF receptor ligand activity in a mammal comprising administering to the mammal an effective amount of the fusion polypeptide described above.

BRIEF DESCRIPTION OF THE FIGURES.

FIG. 1. IEF gel analysis of unmodified and acetylated Flt1(1-3)-Fc proteins. Unmodified Flt1(1-3)-Fc protein is unable to enter the gel due to its >9.3 pI, whereas acetylated Flt1(1-3)-Fc is able to enter the gel and equilibrate at pI 5.2.

FIG. 2. Binding of unmodified Flt1(1-3)-Fc and acetylated Flt1(1-3)-Fc proteins to MATRIGEL® coated plates. Unmodified Flt1(1-3)-Fc proteins binds extensive to extracellular matrix components in Matrigel.RTM., whereas acetylated Flt1(1-3)-Fc does not bind.

FIG. 3. Binding of unmodified Flt1(1-3)-Fc, acetylated Flt1(1-3)-Fc, and pegylated Flt1(1-3)-Fc in a BIACORE™-based assay. Acetylated (columns 13-16), pegylated (columns 17-20), and heparin-treated Flt1(1-3)-Fc (columns 21-24) are each able to completely compete with the

BIACORE™ chip-bound Flt1(1-3)-Fc for VEGF binding as compared to control (columns 1-4) and irrelevant protein (columns 5-8). Unmodified Flt1(1-3)-Fc (columns 5-6) appears to only partially compete with BIACORE™ chip-bound Flt1(1-3)-Fc for VEGF binding. However, washing the bound samples with 0.5M NaCl (columns 7-8) results in a binding profile similar to the modified forms of Flt1(1-3)-Fc, indicating that the unmodified protein is exhibiting non-specific binding to the chip that can be eliminated by the salt wash. However, washing the bound samples with 0.5M NaCl (columns 7-8) results in a binding profile similar to the modified forms of Flt1(1-3)-Fc, indicating that the unmodified protein is exhibiting non-specific binding to the chip that can be eliminated by the salt wash.

FIG. 4. Binding of unmodified Flt1(1-3)-Fc, acetylated Flt1(1-3)-Fc, and pegylated Flt1(1-3)-Fc to VEGF in an ELISA-based assay. Both pegylated and acetylated Flt1(1-3)-Fc proteins bind to VEGF with affinities approaching that of unmodified Flt1(1-3)-Fc.

FIG. 5. Pharmacokinetic profiles of unmodified Flt1(1-3)-Fc, acetylated Flt1(1-3)-Fc, and pegylated Flt1(1-3)-Fc. Balb/c mice (23-28 g) were injected subcutaneously with 4 mg/kg of unmodified, acetylated, or pegylated Flt1(1-3)-Fc. The mice were tail bled at 1, 2, 4, 6, 24 hours, 2 days, and 3 days after injection of protein and the sera were assayed in a standard ELISA-based assay designed to detect Flt1(1-3)-Fc protein. The T_{max} for all of the Flt1(1-3)-Fc proteins was between the 6 hour and 24 hour time points. The C_{max} for the different proteins was as follows: Unmodified: 0.06 μ g/ml-0.15 μ g/ml; acetylated: 1.5 μ g/ml-4.0 μ g/ml; and pegylated: approximately 5 μ g/ml.

FIG. 6A-6B. IEF gel analysis of unmodified and step-acetylated Flt1(1-3)-Fc proteins. Unmodified Flt1(1-3)-Fc protein is unable to enter the gel due to its >9.3 pI, whereas most of the step-acetylated Flt1(1-3)-Fc samples (30-100 fold excess samples) were able to migrate into the gel and equilibrate at pIs ranging between 4.55-8.43, depending on the degree of acetylation.

FIG. 7. Binding of unmodified Flt1(1-3)-Fc and step-acetylated Flt1(1-3)-Fc proteins to MATRIGEL® coated plates. As with the irrelevant control protein, rTie2-Fc, step-acetylated Flt1(1-3)-Fc (20 and 30 fold excess samples) does not exhibit any binding to the Matrigel coated plate, whereas the non-acetylated Flt1(1-3)-Fc protein exhibits significant binding. The 10 fold excess sample shows reduced binding, but the degree of acetylation is not enough to completely block binding to extracellular matrix components.

FIG. 8. Binding of unmodified Flt1(1-3)-Fc and step-acetylated Flt1(1-3)-Fc in a BIACORE™-based assay. At a sub-stoichiometric ratio (0.5 μ g/ml of either unmodified Flt1(1-3) or step-acetylated Flt1(1-3)-Fc vs. 0.2 μ g/ml VEGF), there is not enough Flt1(1-3)-Fc (either unmodified or step-acetylated) in the solution to completely bind the VEGF. At 1.0 μ g/ml, which approximates a 1:1 stoichiometric ratio, the both unmodified and step-acetylated Flt1(1-3)-Fc are better able to compete for VEGF binding, but there is still insufficient Flt1(1-3)-Fc protein (either unmodified or step-acetylated) to completely saturate the available VEGF. However, at 5.0 μ g/ml, which is several times greater than a 1:1 stoichiometric ratio, both the Flt1(1-3)-Fc and the step-acetylated Flt1(1-3)-Fc proteins are able to saturate the VEGF, regardless of the degree of acetylation.

FIG. 9. Pharmacokinetic profiles of unmodified Flt1(1-3)-Fc and step-acetylated Flt1(1-3)-Fc. Balb/c mice (23-28 g) were injected subcutaneously with 4 mg/kg of unmodified or 10, 20, 40, 60 and 100 fold excess samples of step-

acetylated Flt1(1-3)-Fc (3 mice for unmodified, 10, 20 and 40 fold excess samples and 2 mice for 60 and 100 fold excess samples). The mice were tail bled at 1, 2, 4, 6, 24 hours, 2 days and 3 days after injection. The sera were assayed in an ELISA-based assay designed to detect Flt1(1-3)-Fc. The T_{max} for all of the Flt1(1-3)-Fc proteins tested was at the 6 hour time point but the C_{max} was as follows: Unmodified Flt1(1-3)-Fc: 0.06 $\mu\text{g/ml}$; 10 fold excess sample—0.7 $\mu\text{g/ml}$, 20 fold excess sample—2 $\mu\text{g/ml}$, 40 fold excess sample—4 $\mu\text{g/ml}$, 60 fold excess sample—2 $\mu\text{g/ml}$, 100 fold excess sample—1 $\mu\text{g/ml}$.

FIG. 10A-10D. Nucleic acid (SEQ ID NO:1) and deduced amino acid sequence (SEQ ID NO:2) of Flt1(1-3)-Fc.

FIG. 11. Schematic diagram of the structure of Flt1.

FIG. 12A and 12B. Hydrophilicity analysis of the amino acid sequences of Ig domain 2 and Ig domain 3 of Flt1.

FIG. 13A-13D. Nucleic acid (SEQ ID NO:3) and deduced amino acid sequence (SEQ ID NO:4) of Mut1: Flt1(1-3 Δ B)-Fc.

FIG. 14A-14C. Nucleic acid (SEQ ID NO:5) and deduced amino acid sequence (SEQ ID NO:6) of Mut2: Flt1(2-3 Δ A)-Fc.

FIG. 15A-15C. Nucleic acid (SEQ ID NO:7) and deduced amino acid sequence (SEQ ID NO:8) of Mut3: Flt1(2-3)-Fc.

FIG. 16A-16D. Nucleic acid (SEQ ID NO:9) and deduced amino acid sequence (SEQ ID NO:10) of Mut4: Flt1(1-3 $R \rightarrow N$)-Fc.

FIG. 17. Binding of unmodified Flt1(1-3)-Fc, basic region deletion mutant Flt1(1-3)-Fc, and Flt1(1-3) $R \rightarrow N$ mutant proteins in a BIACORE™-based assay. At the sub-stoichiometric ratio (0.25 $\mu\text{g/ml}$ Flt1(1-3)-Fc of unmodified, acetylated or genetically modified samples vs. 01. $\mu\text{g/ml}$ VEGF), there is insufficient Flt1(1-3)-Fc protein to block binding of VEGF to the Flt1(1-3)-Fc immobilized on the BIACORE™ chip. At 0.5 $\mu\text{g/ml}$ of unmodified, acetylated or genetically modified Flt1(1-3)-Fc proteins, the stoichiometric ratio approximates 1:1 and there is an increased ability to block VEGF binding to the BIACORE™ chip. At 1.0 $\mu\text{g/ml}$ of unmodified, acetylated or genetically modified Flt1(1-3)-Fc proteins, which is approximately a 10:1 stoichiometric ratio, the Flt1(1-3)-Fc proteins are able to block binding of VEGF to the BIACORE™ chip, but they are not equivalent. Unmodified, acetylated, and Mut1: Flt1(1-3 Δ B)-Fc are essentially equal in their ability to block VEGF binding, whereas Mut4: Flt1(1-3 $R \rightarrow N$)-Fc is somewhat less efficient at blocking binding.

FIG. 18. Binding of unmodified Flt1(1-3)-Fc, Mut1: Flt1(1-3 Δ B)-Fc, Mut2: Flt1(2-3 Δ B)-Fc, and Flt1(2-3) mutant proteins to Matrigel® coated plates. Unmodified Flt1(1-3)-Fc protein binds avidly to these wells, the Mut3: Flt1(2-3)-Fc protein binds somewhat more weakly, the Mut1: Flt1(1-3 Δ B)-Fc protein binds -more weakly still, and the Mut2: Flt1(2-3 Δ B)-Fc protein shows the best profile, binding more weakly than any of the other mutant proteins. The Mut4: Flt1(1-3 $R \rightarrow N$)-Fc glycosylation mutant protein shows only marginal benefit on the Matrigel assay.

FIG. 19. Binding of unmodified Flt1(1-3)-Fc, Mut1: Flt1(1-3 Δ B)-Fc, Mut2: Flt1(2-3 Δ B)-Fc, and Flt1(2-3) mutant proteins in an ELISA-based assay. At the concentrations tested, unmodified Flt1(1-3)-Fc, Mut1: Flt1(1-3 Δ B)-Fc, Mut2: Flt1(2-3 Δ B)-Fc, and Flt1(2-3) mutant proteins bind VEGF similarly.

FIG. 20. Pharmacokinetic profiles of unmodified Flt1(1-3)-Fc, Mut1: Flt1(1-3 Δ B)-Fc, Mut2: Flt1(2-3 Δ B)-Fc, and Flt1(2-3) mutant proteins. the C_{max} for these reagents was

as follows: Unmodified Flt1(1-3)-Fc—0.15 $\mu\text{g/ml}$; 40 fold molar excess acetylated Flt1(1-3)-Fc—1.5 $\mu\text{g/ml}$; and Mut1: Flt1(1-3 Δ B)-Fc—0.7 $\mu\text{g/ml}$.

FIG. 21A-21C. Nucleotide (SEQ ID NO:11) and deduced amino acid sequence (SEQ ID NO:12) of the modified Flt1 receptor termed Flt1D2.Flk1D3.Fc Δ C1(a).

FIG. 22A-22C. Nucleotide (SEQ ID NO:13) and deduced amino acid sequence (SEQ ID NO:14) of the modified Flt1 receptor termed Flt1D2.VEGFR3D3.Fc Δ C1(a).

FIG. 23. Extracellular Matrix (ECM) Assay. The results of this assay demonstrate that the Flt1D2.Flk1D3.Fc Δ C1(a) and Flt1D2.VEGFR3D3.Fc Δ C1(a) proteins are considerably less sticky to the ECM as compared to the Flt1(1-3)-Fc protein.

FIG. 24A-24C. Nucleotide (SEQ ID NO:15) and deduced amino acid sequence (SEQ ID NO:16) of the modified Flt1 receptor termed VEGFR1R2-Fc Δ C1(a).

FIG. 25A-25C. Phosphorylation assay. At a 1.5 molar excess of either Flt1(1-3)-Fc, Flt1(1-3)-Fc (A40) or transient Flt1D2Flk1D3.Fc Δ C1(a) there is complete blockage of receptor stimulation by these these is modified Flt1 receptors as compared to control media challenge. In contrast, transient Flt1D2VEGFR3D3.Fc Δ C1(a) does not show significant blockage at this molar excess, as compared with VEGF positive control challenge. Similar results are seen in FIG. 25B, where the modified Flt receptors are in a 3-fold molar excess to VEGF165 ligand. In FIG. 25C, where the modified Flt1 receptors are in a 6-fold molar excess to VEGF165 ligand, transient Flt1D2VEGFR3D3.Fc Δ C1(a) can now be shown to be partially blocking VEGF165-induced stimulation of cell-surface receptors.

FIG. 26A-26B. Phosphorylation assay. Detection by Western blot of tyrosine phosphorylated VEGFR2(Flk1) by VEGF165 ligand stimulation shows that cell-surface receptors are not phosphorylated by challenge samples which have VEGF165 preincubated with 1 and 2 fold molar excess (FIG. 26A) or 3 and 4 fold molar excess (FIG. 26B) of either transient Flt1D2Flk1D3.Fc Δ C1(a), stable Flt1D2Flk1D3.Fc Δ C1(a), or transient VEGFR1R2-Fc Δ C1(a). At all modified Flt1 receptor concentrations tested there is complete binding of VEGF165 ligand during the preincubation, resulting in no detectable stimulation of cell-surface receptors by unbound VEGF165 as compared to control media challenge.

FIG. 27. MG/R2 Cell proliferation assay. The following modified Flt receptors Flt1(1-3)-Fc, Flt1D2.Flk1D3.Fc Δ C1(a) and Flt1D2.VEGFR3D3.Fc Δ C1(a), plus an irrelevant receptor termed Tie2-Fc as a negative control, were titrated from 40 nM to 20 pM and incubated on the cells for 1 hr at 37° C. Human recombinant VEGF165 in defined media was then added to all the wells at a concentration of 1.56 nM. The negative control receptor Tie2-Fc does not block VEGF165-induced cell proliferation at any concentration whereas Flt1D2.Flk1D3.Fc Δ C1(a) blocks 1.56 nM VEGF165 with a half maximal dose of 0.8 nM. Flt1(1-3)-Fc and Flt1D2.VEGFR3D3.Fc Δ C1(a) are less effective in blocking VEGF165 in this assay with a half maximal dose of ~2 nM. VEGF165 alone gives a reading of 1.2 absorbance units and the background is 0.38 absorbance units.

FIG. 28. BIACORE™ analysis of Binding Stoichiometry. Binding 20 stoichiometry was calculated as a molar ratio of bound VEGF165 to the immobilized Flt1D2Flk1D3.Fc Δ C1(a) or VEGFR1R2-Fc Δ C1(a), using the conversion factor of 1000 RU equivalent to 1 ng/ml. The results indicated binding stoichiometry of one VEGF165 dimeric molecule per one Flt1D2Flk1D3.Fc Δ C1(a) or VEGFR1R2-Fc Δ C1(a) molecule.

11

FIG. 29 and FIG. 30. Size Exclusion Chromatography Stoichiometry. Flt1D2Flk1D3.FcΔC1(a) or VEGFR1R2-FcΔC1(a) at a concentration of 1 nM (estimated to be 1000 times higher than the KD of the Flt1D2Flk1D3.FcΔC1(a) or VEGFR1R2-FcΔC1(a)/VEGF165 interaction) were mixed with varied concentrations of VEGF165. After incubation, concentrations of the free Flt1D2Flk1D3.FcΔC1(a) in solution were measured. The data shows that the addition of 1 nM VEGF165 into the Flt1D2Flk1D3.FcΔC1(a) solution completely blocks Flt1D2Flk1D3.FcΔC1(a) binding to the VEGF165 surface. This result suggested the binding stoichiometry of one VEGF165 molecule per one Flt1D2Flk1D3.FcΔC1(a) molecule.

FIG. 31. Size Exclusion Chromatography (SEC) under native conditions. Peak #1 represents the Flt1D2Flk1D3.FcΔC1(a)/VEGF165 complex and peak #2 represents unbound VEGF165. Fractions eluted between 1.1 and 1.2 ml were combined and guanidinium hydrochloride (GuHCl) was added to a final concentration 4.5M to dissociate the complex.

FIG. 32. Size Exclusion Chromatography (SEC) under dissociative conditions. To separate the components of the receptor-ligand complex and to determine their molar ratio, 50 .μm.l of dissociated complex was loaded onto a SUPER-OSE™ 12 PC 3.2/30 equilibrated in 6M GuHCl and eluted. Peak #1 represents Flt1D2Flk1D3.FcΔC1(a) and peak #2 represents VEGF165.

FIG. 33, FIG. 34 and FIG. 35. Size Exclusion Chromatography (SEC) with On-Line Light Scattering. Size exclusion chromatography column with a MiniDawn on-line light scattering detector (Wyatt Technology, Santa Barbara, Calif.) and refractive index (RI) detectors (Shimadzu, Kyoto, Japan) was used to determine the molecular weight (MW) of the receptor-ligand complex. As shown in FIG. 33, the elution profile shows two peaks. Peak #1 represents the receptor-ligand complex and peak #2 represents the unbound VEGF165. MW was calculated from LS and RI signals. The same procedure was used to determine MW of the individual components of the receptor-ligand complex. The results of these determinations are as follows: MW of the Flt1D2Flk1D3.FcΔC1(a)/VEGF165 complex at the peak position is 157 300 (FIG. 33), the MW of VEGF165 at the peak position is 44 390 (FIG. 34) and the MW of R1R2 at the peak is 113 300 (FIG. 35).

FIG. 36. Peptide mapping and glycosylation analysis. The disulfide structures and glycosylation sites in Flt1D2.Flk1D3.FcΔC1(a) (SEQ ID NO:12) were determined by a peptide mapping method. There are a total of ten cysteines in Flt1D2.Flk1D3.FcΔC1(a); six of them belong to the Fc region. Cys27 is disulfide bonded to Cys76. Cys121 is disulfide bonded to Cys 182. The first two cysteines in the Fc region (Cys211 and Cys214) form an intermolecular disulfide bond with the same two cysteines in another Fc chain. However, it can not be determined whether disulfide bonding is occurring between same cysteines (Cys211 to Cys211, for example) or between Cys211 and Cys211. Cys216 is disulfide bonded to Cys306. Cys 352 is disulfide bonded to Cys410.

There are five possible N-linked glycosylation sites in Flt1D2.Flk1D3.FcΔC1(a) (SEQ ID NO:12) and are found to be glycosylated to varying degrees. Complete glycosylation is observed at Asn33, Asn193, and Asn282. Partial glycosylation is observed on Asn65 and Asn120. Sites of glycosylation are highlighted by underline in the Figure.

FIG. 37. Pharmacokinetics of Flt1(1-3)-Fc (A40), Flt1D2.Flk1D3.FcΔC1(a) and VEGFR1R2-FcΔC1(a). Balb/c mice were injected subcutaneously with 4 mg/kg of

12

Flt1(1-3)-Fc (A40), CHO transiently expressed Flt1D2.Flk1D3.FcΔC1(a), CHO stably expressed Flt1D2.Flk1D3.FcΔC1(a), and CHO transiently expressed VEGFR1R2-FcΔC1(a). The mice were tail bled at 1, 2, 4, 6, 24 hrs, 2 days, 3 days and 6 days after injection. The sera were assayed in an ELISA designed to detect Flt1(1-3)-Fc (A40), Flt1D2.Flk1D3.FcΔC1(a) or VEGFR1R2-FcΔC1(a). The T_{max} for Flt1(1-3)-Fc (A40) was at 6 hrs while the T_{max} for the transient and stable Flt1D2.Flk1D3.FcΔC1(a) and the transient VEGFR1R2-FcΔC1(a) was 24 hrs. The C_{max} for Flt1(1-3)-Fc (A40) was 8 μg/ml, For both transients (Flt1D2.Flk1D3.FcΔC1(a) and VEGFR1R2-FcΔC1(a)) the C_{max} was 18 μg/ml and the C_{max} for the stable VEGFR1R2-FcΔC1(a) was 30 μg/ml.

FIG. 38. Pharmacokinetics of Flt1(1-3)-Fc (A40), Flt1D2.Flk1D3.FcΔC1(a) and Flt1D2.VEGFR3D3.FcΔC1(a). Balb/c mice were injected subcutaneously with 4 mg/kg of Flt1(1-3)-Fc (A40), CHO transiently expressed Flt1D2.Flk1D3.FcΔC1(a) and CHO transiently expressed Flt1D2.VEGFR3D3.FcΔC1(a). The mice were tail bled at 1, 2, 5, 6, 7, 8, 12, 15 and 20 days after injection. The sera were assayed in an ELISA designed to detect Flt1(1-3)-Fc, Flt1D2.Flk1D3.FcΔC1(a) and Flt1D2.VEGFR3D3.FcΔC1(a). Flt1(1-3)-Fc (A40) could no longer be detected in the serum after day 5 whereas Flt1D2.Flk1D3.FcΔC1(a) and Flt1D2.VEGFR3D3.FcΔC1(a) were detectable for 15 days or more.

FIG. 39. The Ability of Flt1D2.Flk1D3.FcΔC1(a) to Inhibit HT-1080 Fibrosarcoma Tumor Growth In Vivo. Every other day or 2 times per week treatment of SCID mice with Flt1D2.Flk1D3.FcΔC1(a) at 25 mg/Kg significantly decreases the growth of subcutaneous HT-1080 fibrosarcoma tumors.

FIG. 40. The Ability of Flt1D2.Flk1D3.FcΔC1(a) to Inhibit C6 Glioma Tumor Growth In Vivo. Every other day or 2 times a week treatment of SCID mice with Flt1D2.Flk1D3.FcΔC1(a) significantly decreases the growth of subcutaneous C6 glioma tumors at doses as low as 2.5 mg/Kg.

FIG. 41. VEGF-Induced Uterine Hyperpermeability. PMSG injected subcutaneously (5 IU) to induce ovulation in prepubertal female rats results in a surge of estradiol after 2 days which in turn causes an induction of VEGF in the uterus. This induction results in hyperpermeability of the uterus and an increase in uterine wet. Subcutaneous injection of Flt1(1-3)-Fc (A40), Flt1D2.Flk1D3.FcΔC1(a) and Flt1D2.VEGFR3D3.FcΔC1(a) at 25 mg/kg at 1 hr after PMSG injection results in about a 50% inhibition of the increase in uterine wet weight.

FIG. 42A-42B. Assessment of Corpus Luteum Angiogenesis Using Progesterone as a Readout. PMSG was injected subcutaneously (5 IU) to induce ovulation in prepubertal female rats, resulting in a fully functioning corpus luteum containing a dense network of blood vessels that secretes progesterone into the blood stream to prepare the uterus for implantation. The induction of angiogenesis in the corpus luteum requires VEGF. Resting levels of progesterone are about 5 ng/ml and can be induced to 25-40 ng/ml after PMSG. Subcutaneous injection of Flt1(1-3)-Fc (A40) or Flt1D2.Flk1D3.FcΔC1(a) at 25 mg/kg or 5 mg/kg at 1 hr. after PMSG injection resulted in a complete inhibition of the progesterone induction on day 4.

DETAILED DESCRIPTION OF THE
INVENTION

It has been a long standing problem in the art to produce a receptor based VEGF antagonist that has a pharmacokinetic profile that is appropriate for consideration of the antagonist as a therapeutic candidate. Applicants describe herein, for the first time, a chimeric polypeptide molecule, capable of antagonizing VEGF activity, that exhibits improved pharmacokinetic properties as compared to other known receptor-based VEGF antagonists. The chimeric polypeptide molecules described herein thus provide for the first time appropriate molecules for use in therapies in which antagonism of VEGF is a desired result.

The present invention provides for novel chimeric polypeptide molecules formed by fusing a modified extracellular ligand binding domain of the Flt1 receptor to the Fc region of IgG.

The extracellular ligand binding domain is defined as the portion of a receptor that, in its native conformation in the cell membrane, is oriented extracellularly where it can contact with its cognate ligand. The extracellular ligand binding domain does not include the hydrophobic amino acids associated with the receptor's transmembrane domain or any amino acids associated with the receptor's intracellular domain. Generally, the intracellular or cytoplasmic domain of a receptor is usually composed of positively charged or polar amino acids (i.e. lysine, arginine, histidine, glutamic acid, aspartic acid). The preceding 15-30, predominantly hydrophobic or apolar amino acids (i.e. leucine, valine, isoleucine, and phenylalanine) comprise the transmembrane domain. The extracellular domain comprises the amino acids that precede the hydrophobic transmembrane stretch of amino acids. Usually the transmembrane domain is flanked by positively charged or polar amino acids such as lysine or arginine. von Heijne has published detailed rules that are commonly referred to by skilled artisans when determining which amino acids of a given receptor belong to the extracellular, transmembrane, or intracellular domains (See von Heijne, 1995, *BioEssays* 17:25-30). Alternatively, websites on the Internet have become available to provide protein chemists with information about making predictions about protein domains.

The present invention provides for the construction of nucleic acid molecules encoding chimeric polypeptide molecules that are inserted into a vector that is able to express the chimeric polypeptide molecules when introduced into an appropriate host cell. Appropriate host cells include, but are not limited to, bacterial cells, yeast cells, insect cells, and mammalian cells. Any of the methods known to one skilled in the art for the insertion of DNA fragments into a vector may be used to construct expression vectors encoding the chimeric polypeptide molecules under control of transcriptional/translational control signals. These methods may include *in vitro* recombinant DNA and synthetic techniques and *in vivo* recombinations (genetic recombination) (See Sambrook, et al., *Molecular Cloning, A Laboratory Manual*, Cold Spring Harbor Laboratory; *Current Protocols in Molecular Biology*, Eds. Ausubel, et al., Greene Publ. Assoc., Wiley-Interscience, NY).

Expression of nucleic acid molecules encoding the chimeric polypeptide molecules may be regulated by a second nucleic acid sequence so that the chimeric polypeptide molecule is expressed in a host transformed with the recombinant DNA molecule. For example, expression of the chimeric polypeptide molecules described herein may be controlled by any promoter/enhancer element known in the

art. Promoters which may be used to control expression of the chimeric polypeptide molecules include, but are not limited to, the long terminal repeat as described in Squinto et al., (1991, *Cell* 65:1-20); the SV40 early promoter region (Bemoist and Chambon, 1981, *Nature* 290:304-310), the CMV promoter, the M-MuLV 5' terminal repeat the promoter contained in the 3' long terminal repeat of Rous sarcoma virus (Yamamoto, et al., 1980, *Cell* 22:787-797), the herpes thymidine kinase promoter (Wagner et al., 1981, *Proc. Natl. Acad. Sci. U.S.A.* 78:144-1445), the regulatory sequences of the metallothioneine gene (Brinster et al., 1982, *Nature* 296:39-42); prokaryotic expression vectors such as the β -lactamase promoter (Villa-Kamaroff, et al., 1978, *Proc. Natl. Acad. Sci. U.S.A.* 75:3727-3731), or the tac promoter (DeBoer, et al., 1983, *Proc. Natl. Acad. Sci. U.S.A.* 80:21-25, see also "Useful proteins from recombinant bacteria" in *Scientific American*, 1980, 242:74-94); promoter elements from yeast or other fungi such as the Gal 4 promoter, the ADH (alcohol dehydrogenase) promoter, PGK (phosphoglycerol kinase) promoter, alkaline phosphatase promoter, and the following animal transcriptional control regions, which exhibit tissue specificity and have been utilized in transgenic animals: elastase I gene control region which is active in pancreatic acinar cells (Swift et al., 1984, *Cell* 38:639-646; Ornitz et al., 1986, *Cold Spring Harbor Symp. Quant. Biol.* 50:399-409; MacDonald, 1987, *Hepatology* 7:425-515); insulin gene control region which is active in pancreatic beta cells (Hanahan, 1985, *Nature* 315:115-122), immunoglobulin gene control region which is active in lymphoid cells (Grosschedl et al., 1984, *Cell* 38:647-658; Adames et al., 1985, *Nature* 318:533-538; Alexander et al., 1987, *Mol. Cell. Biol.* 7:1436-1444), mouse mammary tumor virus control region which is active in testicular, breast, lymphoid and mast cells (Leder et al., 1986, *Cell* 45:485-495), albumin gene control region which is active in liver (Pinkert et al., 1987, *Genes and Devel.* 1:268-276), alpha-fetoprotein gene control region which is active in liver (Krumlauf et al., 1985, *Mol. Cell. Biol.* 5:1639-1648; Hammer et al., 1987, *Science* 235:53-58); alpha 1-antitrypsin gene control region which is active in the liver (Kelsey et al., 1987, *Genes and Devel.* 1:161-171), beta-globin gene control region which is active in myeloid cells (Mogram et al., 1985, *Nature* 315:338-340; Kollias et al., 1986, *Cell* 46:89-94); myelin basic protein gene control region which is active in oligodendrocyte cells in the brain (Readhead et al., 1987, *Cell* 48:703-712); myosin light chain-2 gene control region which is active in skeletal muscle (Shani, 1985, *Nature* 314:283-286), and gonadotropic releasing hormone gene control region which is active in the hypothalamus (Mason et al., 1986, *Science* 234:1372-1378).

Thus, according to the invention, expression vectors capable of being replicated in a bacterial or eukaryotic host comprising chimeric polypeptide molecule-encoding nucleic acid as described herein, are used to transfect the host and thereby direct expression of such nucleic acids to produce the chimeric polypeptide molecules, which may then be recovered in a biologically active form. As used herein, a biologically active form includes a form capable of binding to VEGF.

Expression vectors containing the chimeric nucleic acid molecules described herein can be identified by three general approaches: (a) DNA-DNA hybridization, (b) presence or absence of "marker" gene functions, and (c) expression of inserted sequences. In the first approach, the presence of a foreign gene inserted in an expression vector can be detected by DNA-DNA hybridization using probes comprising

15

sequences that are homologous to the inserted chimeric polypeptide molecule sequences. In the second approach, the recombinant vector/host system can be identified and selected based upon the presence or absence of certain "marker" gene functions (e.g., thymidine kinase activity, resistance to antibiotics, transformation phenotype, occlusion body formation in baculovirus, etc.) caused by the insertion of foreign genes in the vector. For example, if the chimeric polypeptide molecule DNA sequence is inserted within the marker gene sequence of the vector, recombinants containing the insert can be identified by the absence of the marker gene function. In the third approach, recombinant expression vectors can be identified by assaying the foreign gene product expressed by the recombinant. Such assays can be based, for example, on the physical or functional properties of the chimeric polypeptide molecules.

Cells of the present invention may transiently or, preferably, constitutively and permanently express the chimeric polypeptide molecules.

The chimeric polypeptide molecules may be purified by any technique which allows for the subsequent formation of a stable, biologically active chimeric polypeptide molecule. For example, and not by way of limitation, the factors may be recovered from cells either as soluble proteins or as inclusion bodies, from which they may be extracted quantitatively by 8M guanidinium hydrochloride and dialysis (see, for example, Builder, et al., U.S. Pat. No. 5,663,304). In order to further purify the factors, conventional ion exchange chromatography, hydrophobic interaction chromatography, reverse phase chromatography or gel filtration may be used.

In one embodiment of the invention, the nucleotide sequence encoding the first component is upstream of the nucleotide sequence encoding the second component. In another embodiment of the invention, the nucleotide sequence encoding the first component is downstream of the nucleotide sequence encoding the second component. Further embodiments of the invention may be prepared in which the order of the first, second and third fusion polypeptide components are rearranged. For example, if the nucleotide sequence encoding the first component is designated 1, the nucleotide sequence encoding the second component is designated 2, and the nucleotide sequence of the third component is designated 3, then the order of the components in the isolated nucleic acid of the invention as read from 5' to 3' may be any of the following six combinations: 1,2,3; 1,3,2; 2,1,3; 2,3,1; 3,1,2; or 3,2,1.

The present invention also has diagnostic and therapeutic utilities. In particular embodiments of the invention, methods of detecting aberrancies in the function or expression of the chimeric polypeptide molecules described herein may be used in the diagnosis of disorders. In other embodiments, manipulation of the chimeric polypeptide molecules or agonists or antagonists which bind the chimeric polypeptide molecules may be used in the treatment of diseases. In further embodiments, the chimeric polypeptide molecule is utilized as an agent to block the binding of a binding agent to its target.

By way of example, but not limitation, the method of the invention may be useful in treating clinical conditions that are characterized by vascular permeability, edema or inflammation such as brain edema associated with injury, stroke or tumor; edema associated with inflammatory disorders such as psoriasis or arthritis, including rheumatoid arthritis; asthma; generalized edema associated with burns; ascites

16

and pleural effusion associated with tumors, inflammation or trauma; chronic airway inflammation; capillary leak syndrome; sepsis;

kidney disease associated with increased leakage of protein; and eye disorders such as age related macular degeneration and diabetic retinopathy.

An amino acid sequence analysis of Flt1(1-3)-Fc revealed the presence of an unusually high number (46) of the basic amino acid residue lysine. An IEF analysis of Flt1(1-3)-Fc showed that this protein has pI greater than 9.3, confirming the prediction that the protein is very basic. It was hypothesized that the basic nature of Flt1(1-3)-Fc protein was causing it to bind to extracellular matrix components and that this interaction might be the cause of the extremely short detectable circulating serum half-life exhibited by Flt1(1-3)-Fc when injected into mice. In order to test this hypothesis, Flt1(1-3)-Fc protein was acetylated at the lysine residues to reduce the basic charge. Acetylated Flt1(1-3)-Fc was then tested in the assays described infra.

The following examples are offered by way of illustration and not by way of limitation.

EXAMPLES

Example 1

Expression of Flt1(1-3)-Fc Protein in CHO K1 Cells

Using standard molecular biology techniques (see e.g., Molecular Cloning, A Laboratory Manual (Sambrook, et al., Cold Spring Harbor Laboratory), Current Protocols in Molecular Biology (Eds. Ausubel, et al., Greene Publ. Assoc., Wiley-Interscience, NY), the gene encoding Flt1(1-3)-Fc was inserted into the expression vector pEE14.1 (Lonza Biologics, plc) at a multiple cloning site downstream of the CMV promoter. CHO K1 cells were transfected with the pEE14.1/Flt1(1-3)-Fc DNA construct using lipofectamine (Gaithersburg, Md.). The transfected CHO K1 cells were grown in glutamine-free DMEM (JRH, Kansas City, Mo.) containing 25 μ M methionine sulfoximine (MSX) from Sigma Inc., St. Louis, Mo., and high recombinant protein expressors were obtained by screening the CHO K1 cell supernatants from over 100 hand-picked colony isolates using a standard immunoassay which captures and detects human Fc. The selected hand-picked clone was amplified in the presence of 100 μ M MSX followed by a second round of screening of the amplified clones. The highest producing clone had a specific productivity of recombinant Flt1(1-3)-Fc protein of 55 pg/cell/day.

The selected clone was expanded in 225 cm² T-flasks (Corning, Acton, Mass.) and then into 8.5 L roller bottles (Corning, Acton, Mass.) using the cell culture media described supra. Cells were removed from the roller bottles by standard trypsinization and put into 3.5 L of suspension medium. The suspension medium is comprised of glutamine-free ISCHO medium (Irvine Scientific, Santa Ana, Calif.) containing 5% fetal bovine serum (FBS from Hyclone Labs, Logan, Utah), 100 μ M MSX and GS supplement (JRH Scientific, Kansas City, Mo.) in a 5 L Celligen bioreactor (New Brunswick Scientific, New Brunswick, N.J.) at a density of 0.3×10^6 cells/mL. After the cells reached a density of 3.6×10^6 /mL and were adapted to suspension they were transferred to a 60 L bioreactor (ABEC, Allentown, Pa.) at a density of 0.5×10^6 cells/mL in 20 L of ISCHO medium with 5% fetal bovine serum. After two days an additional 20 L of ISCHO+5% fetal bovine serum was added

17

to the bioreactor. The cells were allowed to grow for an additional two days reaching a final density of 3.1×10^9 cells/mL, and a final Flt1(1-3)-Fc concentration at harvest was 95 mg/L. At harvest the cells were removed by tangential flow filtration using 0.45 μ m Prostag Filters (Millipore, Inc., Bedford, Mass.).

Example 2

Purification of Flt1(1-3)-Fc Protein Obtained from CHO K1 Cells

Flt1(1-3)-Fc protein was initially purified by affinity chromatography. A Protein A column was used to bind, with high specificity, the Fc portion of the molecule. This affinity-purified protein was then concentrated and passed over a SEC column. The protein was then eluted into the formulation buffer. The following describes these procedures in detail.

Materials and Methods

All chemicals were obtained from J. T. Baker, Phillipsburg, N.J. with the exception of PBS, which was obtained as a 10.times. concentrate from Life Technologies, Gaithersburg, Md. Protein A Fast Flow and SUPERDEX™ 200 preparation grade resins were obtained from Pharmacia, Piscataway, N.J. Equipment and membranes for protein concentration were obtained from Millipore, Bedford, Mass.

Approximately 40 L of 0.45 μ m-filtered CHO conditioned media containing Flt1(1-3)-Fc protein was applied to a 290 mL Protein A Fast Flow column (10 cm diameter) that had been equilibrated with PBS. The column was washed with PBS containing 350 mM NaCl and 0.02% CHAPS and the bound protein was eluted with 20 mM Citric Acid containing 10 mM Na_2HPO_4 . The single peak in the elution was collected and its pH was raised to neutrality with 1M NaOH. The eluate fractions was concentrated to approximately 9 mg/mL using 10K regenerated cellulose membranes by both tangential flow filtration and by stirred cell concentration. To remove aggregates and other contaminants, the concentrated protein was applied to a column packed with Superdex 200 preparation grade resin (10 cm \times 55 cm) and run in PBS containing 5% glycerol. The main peak fractions were pooled, sterile filtered, aliquoted and stored at -80°C .

Example 3

Acetylation of Flt1(1-3)-Fc Protein

Two milligrams of Flt1(1-3)-Fc protein were acetylated as described in the instruction manual provided with the sulfo-NHS-acetate modification kit (Pierce Chemical Co., Rockford, Ill., Cat.#26777).

Example 4

Characterization of Acetylated Flt1(1-3)-Fc Protein

(a) IEF analysis: Flt1(1-3)-Fc and acetylated Flt1(1-3)-Fc were analyzed by standard IEF analysis. As shown in FIG. 1, Flt1(1-3)-Fc protein is not able to migrate into the gel and therefore must have a pI greater than 9.3, the highest pI in the standard. However, acetylated Flt1(1-3)-Fc is able to migrate into the gel and equilibrate at a pI of approximately 5.2. This result demonstrates that acetylation reduces the net positive charge of the protein and therefore its pI considerably.

18

(b.) Binding to Extracellular Matrix Components

To test for binding to extracellular matrix components, Flt1(1-3)-Fc and acetylated Flt1(1-3)-Fc were tested in an assay designed to mimic the interaction with extracellular matrix components. In this assay, 96-well tissue culture plates are coated with Matrigel (Biocoat MATRIGEL® matrix thin layer 96 well plate, Catalog #40607, Becton Dickinson Labware, Bedford, Mass.). The plates are incubated with varying concentrations of either Flt1(1-3)-Fc, acetylated Flt1(1-3)-Fc, or rTie2-Fc (an irrelevant control) protein are added to the wells. The plates are incubated for 1-2 hours at either room temperature or 37°C . degrees and then detection of bound proteins is accomplished by adding a secondary alkaline phosphatase-conjugated anti-human Fc antibody to the wells. Finally, alkaline phosphatase substrate is added to the wells and optical density is measured. FIG. 2 shows the results of this assay. Like the irrelevant control protein rTie2-Fc, acetylated Flt1(1-3)-Fc does not exhibit any binding to the Matrigel coated plate, whereas the non-acetylated Flt1(1-3)-Fc protein exhibits significant binding. This result indicates that acetylation of basic amino acid residues is an effective way to interfere with the charge interactions that exist between positively charged proteins and the negatively charged extracellular matrix components they are exposed to in vivo.

Example 5

Pegylation of Flt1(1-3)-Fc Protein

Although pegylation (polyethylene glycol—PEG) of proteins has been shown to increase their in vivo potency by enhancing stability and bioavailability while minimizing immunogenicity (see references cited supra), it is counter-intuitive that pegylating molecules that are too large to be filtered by the kidney glomeruli would improve their pharmacokinetic properties. Without being bound by theory, Applicants postulated that pegylation of the Flt1(1-3)-Fc molecules could improve the pharmacokinetic properties, possibly not by altering the positive charge or by decreasing the pI of Flt1(1-3)-Fc, but rather by physically shielding the positive charges from interacting with the extracellular matrix. Applicants decided to attempt to improve the pharmacokinetic properties of Flt1(1-3)-Fc molecules by attaching strands of 20K PEGs as described infra.

Materials and Methods

Purified Flt1(1-3)-Fc derived from CHO cells (see supra) was used in the following pegylation experiments. Functionalized PEGs were obtained from Shearwater Polymers, Huntsville, Ala.; Bicine from Sigma, St Louis, Mo.; Superose 6 column from Pharmacia, Piscataway, N.J.; PBS as a 10 \times concentrate from Life Technologies, Gaithersburg, Md.; Glycerol from J. T. Baker, Phillipsburg, N.J.; and Bis-Tris precast gels from Novex, Calif.

20K PEG strands functionalized with amine-specific terminal moieties were used in small-scale reaction studies that were set-up to evaluate different reaction conditions in which the PEG:protein stoichiometry was varied. Based on these reactions and the analyses of samples on standard SDS-PAGE, Flt1(1-3)-Fc at a concentration of 1.5 mg/mL was reacted at pH 8.1 with 20K SPA-PEG (PEG succinimidyl propionate) molecules at a PEG-to-Flt1(1-3)-Fc monomer molar ratio of 1:6. The reaction was allowed to proceed at 8°C . overnight. For initial purification, the reaction products were applied to a 10 mm \times 30 cm Superose 6 column equilibrated with PBS containing 5% Glycerol. The column appeared to separate pegylated Flt1(1-3)-Fc molecules based on the extent of pegylation. Fractions corresponding to what appeared to be primarily mono-pegylated

19

and di-pegylated dimeric Flt1(1-3)-Fc, as judged by banding patterns on reducing and non-reducing SDS-PAGE gels were pooled. The protein concentration was determined by measuring absorbance at 280 nm. The pegylated Flt1(1-3)-Fc protein was sterile filtered, aliquoted and stored at -40° C.

Example 6

Binding of Unmodified, Acetylated, and Pegylated Flt1(1-3)-Fc in a BIACORE™-Based Assay

Unmodified, acetylated, and pegylated Flt1(1-3)-Fc proteins were tested in a BIACORE™-based assay to evaluate their ability to bind to the Flt1 ligand, VEGF. In this assay, unmodified Flt1(1-3)-Fc protein was immobilized on the surface of a BIACORE™ chip (see BIACORE™ Instruction Manual, Pharmacia, Inc., Piscataway, N.J., for standard procedures) and a sample containing 0.2 µg/ml VEGF and either unmodified Flt1(1-3)-Fc, acetylated Flt1(1-3)-Fc or pegylated Flt1(1-3)-Fc (each at 25 µg/ml) was passed over the Flt1(1-3)-Fc-coated chip. To minimize the effects of non-specific binding, the bound samples were washed with a 0.5M NaCl wash. In one sample, unmodified Flt1(1-3)-Fc was mixed with heparin. Heparin is a negatively charged molecule and the Flt1(1-3)-Fc protein is a positively charged molecule, so when the two molecules are mixed together, they should interact through their respective charges. This essentially neutralizes Flt1(1-3)-Fc's inherent positive charge making the molecule behave as if it has been chemically or genetically modified so as to reduce its charge and its tendency to bind via charge interactions. As shown in FIG. 3, acetylated (columns 13-16), pegylated (columns 17-20), and heparin-treated Flt1(1-3)-Fc (columns 21-24) are each able to completely compete with the BIACORE™ chip-bound Flt1(1-3)-Fc for VEGF binding as compared to control (columns 1-4) and irrelevant protein (columns 5-8). Unmodified Flt1(1-3)-Fc (columns 5-6) appeared to only partially compete with BIACORE™ chip-bound Flt1(1-3)-Fc for VEGF binding. However, washing the bound samples with 0.5M NaCl (columns 7-8) resulted in a binding profile similar to the modified forms of Flt1(1-3)-Fc, indicating that the unmodified protein was exhibiting non-specific binding to the chip that could be eliminated by the salt wash.

Example 7

Binding of Unmodified, Acetylated, and Pegylated Flt1(1-3)-Fc in an ELISA-Based Assay

Unmodified, acetylated, and pegylated Flt1(1-3)-Fc proteins were tested in a standard ELISA-based assay to evaluate their ability to bind the Flt1 receptor ligand VEGF. As shown in FIG. 4, both pegylated and acetylated Flt1(1-3)-Fc proteins are capable of binding to VEGF, demonstrating that modifying the protein either by pegylation or acetylation does not destroy its ability to bind its ligand.

Example 8

Pharmacokinetic Analysis of Unmodified Flt1(1-3)-Fc, Acetylated Flt1(1-3)-Fc, and Pegylated Flt1(1-3)-Fc

In vivo experiments were designed to assess the pharmacokinetic profiles of unmodified Flt1(1-3)-Fc, acetylated Flt1(1-3)-Fc, and pegylated Flt1(1-3)-Fc protein. Balb/c

20

mice (23-28 g; 3 mice/group) were injected subcutaneously with 4 mg/kg of unmodified, acetylated, or pegylated Flt1(1-3)-Fc. The mice were tail bled at 1, 2, 4, 6, 24 hours, 2 days, and 3 days after injection of protein. The sera were assayed in a standard ELISA-based assay designed to detect Flt1(1-3)-Fc protein. Briefly, the assay involves coating an ELISA plate with VEGF, binding the unmodified, acetylated, or pegylated Flt1(1-3)-Fc-containing sera, and reporting with an anti-Fc antibody linked to alkaline phosphatase. As shown in FIG. 5, the T_{max} for all of the Flt1(1-3)-Fc proteins was between the 6 hour and 24 hour time points. The C_{max} for the different proteins was as follows: Unmodified: 0.06 µg/ml-0.15 µg/ml; acetylated: 1.5 µg/ml-4.0 µg/ml; and pegylated: approximately 5 µg/ml.

Example 9

Step-Acetylation of Flt1(1-3)-Fc

To determine what minimal amount of acetylation is necessary to eliminate binding to extracellular matrix components, an experiment was designed that acetylated the Flt1(1-3)-Fc protein in a step-wise fashion by using increasing amounts of molar excess of acetylation reagent in the acetylation reaction mixture. The range of molar excess was as follows: 0, 10, 20, 30, 40, 50, 60, 70, 80, 90, and 100 moles of acetylation reagent per 1 mole of Flt1(1-3)-Fc monomer. The reactions were performed as detailed in the instruction manual provided with the sulfo-NHS-Acetate modification kit (Pierce Chemical Co., Rockford, Ill., Cat.# 26777).

Example 10

Characterization of Step-Acetylated Flt1(1-3)-Fc

(a.) IEF analysis Unmodified Flt1(1-3)-Fc and step-acetylated Flt1(1-3)-Fc proteins were analyzed by standard IEF analysis. As shown in FIG. 6A-6B, unmodified Flt1(1-3)-Fc protein was not able to migrate into the gel due to its extremely high pI (greater than 9.3). However, most of the step-acetylated Flt1(1-3)-Fc samples (30-100 fold molar excess samples) were able to migrate into the gel and equilibrate at pIs ranging between 4.55-8.43, depending on the degree of acetylation of the protein. This result demonstrates that acetylation can change the positive charge of the protein in a dose-dependent manner and that reduction of the pI can be controlled by controlling the degree of acetylation.

(b.) Binding of Step-Acetylated Flt1(1-3)-Fc to Extracellular Matrix Components

To test for binding to extracellular matrix components, Flt1(1-3)-Fc and step-acetylated Flt1(1-3)-Fc were tested in the above-described assay designed to mimic the interaction with extracellular matrix components. Varying concentrations of either unmodified Flt1(1-3)-Fc, step-acetylated Flt1(1-3)-Fc (10, 20, and 30 fold molar excess samples), or rTie2-Fc (an irrelevant control) protein were added to the wells. The plates were incubated for 1-2 hours at room temperature or 37° C. and then detection of bound proteins was accomplished by adding a secondary alkaline phosphatase-conjugated anti-human Fc antibody to the wells. Alkaline phosphatase substrate was subsequently added to the wells and optical density measured. FIG. 7 shows the results of this assay. Like the irrelevant control protein rTie2-Fc, step-acetylated Flt1(1-3)-Fc (20 and 30 fold molar excess samples) did not exhibit any significant

binding to the Matrigel coated plate, whereas the non-acetylated Flt1(1-3)-Fc protein exhibited significant binding. The binding is saturable, indicating that the Flt1(1-3)-Fc protein may be binding to specific sites, rather than a more general charge-mediated interaction that might not be saturable. The 10 fold molar excess sample showed reduced binding, but the degree of acetylation was not enough to completely block binding to extracellular matrix components. The 20 fold molar excess and higher samples displayed no detectable binding, despite the fact that by IEF analysis (FIG. 6A and 6B) the lower molar excess samples still had a large net positive charge. This result demonstrates that it is not necessary to completely acetylate all available basic amino acids in order to eliminate binding to extracellular matrix components.

(c.) Binding of Step-Acetylated Flt1(1-3)-Fc in a Biacore-Based Assay.

(c.) Binding of Step-Acetylated Flt1(1-3)-Fc in a BIA-CORE™-Based Assay

Unmodified and step-acetylated Flt1(1-3)-Fc proteins were tested in a BIA-CORE™-based assay to evaluate their ability to bind to the Flt1 ligand, VEGF. In this assay, unmodified Flt1(1-3)-Fc protein (0.5, 1.0, or 5.0 µg/ml) was immobilized on the surface of a BIA-CORE™ chip (see BIA-CORE™ Instruction Manual, Pharmacia, Inc., Piscataway, N.J., for standard procedures) and a solution containing 0.2 µg/ml VEGF and either unmodified Flt1(1-3)-Fc (at either 0.5, 1.0, or 5.0 µg/ml) or 10 different step-acetylated Flt1(1-3)-Fc samples (at 0.5, 1.0, or 5.0 µg/ml each) were passed over the Flt1 (1-3)-Fc-coated chip. As shown in FIG. 8, at a sub-stoichiometric ratio (0.5 µg/ml of either unmodified Flt1(1-3) or step-acetylated Flt1(1-3)-Fc vs. 0.2 µg/ml VEGF), there is not enough Flt1(1-3)-Fc (either unmodified or step-acetylated) in the solution to completely bind the VEGF. At 1.0 µg/ml, which approximates a 1:1 stoichiometric ratio, both unmodified and step-acetylated Flt1(1-3)-Fc are better able to compete for VEGF binding, but there is still insufficient Flt1(1-3)-Fc protein (either unmodified or step-acetylated) to completely bind the available VEGF. However, at 5.0 µg/ml, which is several times greater than a 1:1 stoichiometric ratio, both the Flt1(1-3)-Fc and the step-acetylated Flt1(1-3)-Fc proteins are able to bind the VEGF, regardless of the degree of acetylation. This clearly demonstrates that acetylation does not alter Flt1(1-3)-Fc's ability to bind VEGF.

(d.) Pharmacokinetic Analysis of Step-Acetylated Flt1(1-3)-Fc

In vivo experiments were designed to assess the pharmacokinetic profiles of unmodified Flt1(1-3)-Fc and step-acetylated Flt1(1-3)-Fc protein. Balb/c mice (23-28 g) were injected subcutaneously with 4 mg/kg of unmodified or 10, 20, 40, 60 and 100 fold molar excess samples of step-acetylated Flt1(1-3)-Fc (3 mice for unmodified, 10, 20 and 40 fold molar excess samples and 2 mice for 60 and 100 fold molar excess samples). The mice were tail bled at 1, 2, 4, 6, 24 hours, 2 days and 3 days after injection. The sera were assayed in an ELISA-based assay designed to detect Flt1 (1-3)-Fc (described supra). FIG. 9 details the results of this study. The T_{max} for all of the Flt1(1-3)-Fc proteins tested was at the 6 hour time point but the C_{max} was as follows: Unmodified Flt1(1-3)-Fc: 0.06 µg/ml; 10 fold molar excess sample:—0.7 µg/ml, 20 fold molar excess sample—2 µg/ml, 40 fold molar excess sample—4 µg/ml, 60 fold molar excess sample—2 µg/ml, 100 fold molar excess sample—1 µg/ml.

This results demonstrates that acetylation or pegylation of Flt1(1-3)-Fc significantly improves its pharmacokinetic profile.

Example 11

Construction of Flt1(1-3)-Fc Basic Region Deletion Mutant Designated Mut1: Flt1(1-3_{ΔB})-Fc

Based on the observation that acetylated Flt1(1-3)-Fc, which has a pI below 6, has much better pharmacokinetics than the highly positive unmodified Flt1(1-3)-Fc (pI>9.3), it was asked whether the difference in pharmacokinetics could be attributed to the net charge of the protein, which made it stick to negatively charged extracellular matrix components, or whether there were perhaps specific locations on the surface of the Flt1(1-3)-Fc protein that constituted specific binding sites for extracellular matrix components. For example, many proteins are known to have heparin binding sites, often consisting of a cluster of basic residues. Sometimes these residues are found in a cluster on the primary sequence of the protein; some of the literature has identified "consensus sequences" for such heparin binding sites (see for example Hileman, et al., 1998, Bioessays 20(2):156-67). In other cases, the known crystal structure of a protein reveals a cluster of positively charged residues on the surface of a protein, but the residues come from different regions of the primary sequence and are only brought together when the protein folds into its tertiary structure. Thus it is difficult to deduce whether an isolated amino acid residue forms part of a cluster of basic residues on the surface of the protein. However, if there is a cluster of positively charged amino acid residues in the primary sequence, it is not unreasonable to surmise that the residues are spatially close to one another and might therefore be part of an extracellular matrix component binding site. Flt1 receptor has been studied extensively and various domains have been described (see for example Tanaka et al., 1997, Jpn. J. Cancer Res 88:867-876). Referring to the nucleic acid and amino acid sequence set forth in FIG. 10A-10D of this application, one can identify the signal sequence for secretion which is located at the beginning of the sequence and extends to the glycine coded for by nucleotides 76-78. The mature protein begins with Ser-Lys-Leu-Lys, starting at nucleotide 79 of the nucleic acid sequence. Flt1 Ig domain 1 extends from nucleotide 79 to 393, ending with the amino acids Ser-Asp-Thr. Flt1 Ig domain 2 extends from nucleotide 394 to 687 (encoding Gly-Arg-Pro to Asn-Thr-Ile), and Flt1 Ig domain 3 extends from nucleotides 688 to 996 (encoding Ile-Asp-Val to Asp-Lys-Ala). There is a bridging amino acid sequence, Gly-Pro-Gly, encoded by nucleotides 997-1005, followed by the nucleotide sequence encoding human Fc (nucleotides 1006-1701 or amino acids Glu-Pro-Lys to Pro-Gly-Lys-stop).

A more detailed analysis of the Flt1 amino acid sequence reveals that there is a cluster, namely, amino acid residues 272-281 (KNKRASVRR) of FIG. 10A-10D, in which 6 out of 10 amino acid residues are basic. This sequence is located in Flt1 Ig domain 3 of the receptor (see FIG. 11), which is not itself essential for binding of VEGF ligand, but which confers a higher affinity binding to ligand. An alignment of the sequence of Ig domain 3 with that of Ig domain 2 reveals that in this region, there is very poor alignment between the two Ig domains, and that there are about 10 additional amino acids in Ig domain 3. An analysis of the hydrophobicity profiles MACVECTOR™ computer software) of these two domains clearly indicates the presence of a hydrophilic

23

region in the protein (FIG. 12A-12B). These observations raised the possibility that the actual three dimensional conformation of Flt1 Ig domain 3 allowed for some type of protrusion that is not in Flt1 Ig domain 2. To test this hypothesis, the 10 additional amino acids were deleted and the resulting protein was tested to see whether the deletion would affect the pharmacokinetics favorably without seriously compromising the affinity of the receptor for VEGF. This DNA construct, which was constructed using standard molecular biology techniques (see e.g., Molecular Cloning, A Laboratory Manual (Sambrook, F et al., Cold Spring Harbor Laboratory), Current Protocols in Molecular Biology (Eds. Ausubel, et al., Greene Publ. Assoc., Wiley-Interscience, N.Y.) in the mammalian expression vector pMT21, (Genetics Institute, Inc., Cambridge, Mass.), is referred to as Mut1: Flt1(1-3ΔB)-Fc. The Mut1: Flt1(1-3ΔB)-Fc construct was derived from Flt1(1-3)-Fc by deletion of nucleotides 814-843 (set forth in FIG. 10A-10D), which deletes the highly basic 10-amino acid residue sequence Lys-Asn-Lys-Arg-Ala-Ser-Val-Arg-Arg-Arg from Flt1 Ig domain 3.

The final DNA construct was sequence-verified using an ABI 373A DNA sequencer and Taq Dideoxy Terminator Cycle Sequencing Kit (Applied Biosystems, Inc., Foster City, Calif.). The sequence of Mut1: Flt1(1-3_{ΔB})-Fc is set forth in FIG. 13A-13D.

Example 12

Construction of Flt1(1-3)-Fc Basic Region Deletion Mutant Designated Mut2: Flt1(2-3_{ΔB})-Fc

A second deletion mutant construct, designated Mut2: Flt1(2-3_{ΔB})-Fc, was derived from the Mut1: Flt1(1-3_{ΔB})-Fc construct by deletion of Flt1 Ig domain 1 encoded by nucleotides 79-393 (see FIG. 10A-10D); for convenience, nucleotides 73-78 (TCA GGT) were changed to TCC GGA. This introduced a restriction site (BspE1) without altering the associated amino acid sequence, Ser-Gly. This DNA construct, which was constructed using standard molecular biology techniques (see e.g., Molecular Cloning, A Laboratory Manual (Sambrook, et al., Cold Spring Harbor Laboratory), Current Protocols in Molecular Biology (Eds. Ausubel, et al., Greene Publ. Assoc., Wiley-Interscience, NY) in the mammalian expression vector pMT21 (Genetics Institute, Inc., Cambridge, Mass.), was also sequence-verified using an ABI 373A DNA sequencer and Taq Dideoxy Terminator Cycle Sequencing Kit (Applied Biosystems, Inc., Foster City, Calif.). The sequence of Mut2: Flt1(2-3_{ΔB})-Fc is set forth in FIG. 14A-14C.

Example 13

Construction of Flt1(1-3)-Fc Deletion Mutant Designated Mut3: Flt1(2-3)-Fc

A third deletion mutant construct, designated Mut3: Flt1(2-3)-Fc, was constructed the same way as the Mut2: Flt1(2-3_{ΔB})-Fc construct, except that Flt1 Ig domain 3 was left intact (the basic region amino acids were not deleted). The construct was constructed using standard molecular biology techniques and the final construct was sequence-verified as described supra. The sequence of Mut3: Flt1(2-3)-Fc is set forth in FIG. 15A-15C.

24

Example 14

Construction of Flt(1-3)-Fc Basic Region N-glycosylation Mutant Designated Mut4: Flt1(1-3_{R→N})-Fc

A final construct was made in which a N-glycosylation site was introduced into the middle of the basic region of Flt1 Ig domain 3. This construct was designated Mut4: Flt1(1-3_{R→N})-Fc and was made by changing nucleotides 824-825 from GA to AC, consequently changing the coded Arg residue (AGA) into an Asn residue (AAC) (see FIG. 10A-10D). The resulting amino acid sequence is therefore changed from Arg-Ala-Ser to Asn-Ala-Ser, which matches the canonical signal (Asn-Xxx-Ser/Thr) for the addition of a N-glycosylation site at the Asn residue. The sequence of Mut4: Flt1(1-3_{R→N})-Fc is set forth in FIG. 16A-16D.

Example 15

Characterization of Acetylated Flt1(1-3)-Fc Mut1: Flt1(1-3_{ΔB})-Fc, and Mut4: Flt1(1-3_{R→N})-Fc mutants

(a.) Binding to Extracellular Matrix Components

To determine whether the three modified proteins were more or less likely to have improved pharmacokinetic properties, Matrigel coated 96-well dishes (as described supra) were incubated with varying concentrations of the mutant proteins and detected with anti-human Fc/alkaline-phosphatase conjugated antibodies. As shown in FIG. 18, this experiment showed that while the unmodified Flt1(1-3)-Fc protein could bind avidly to these wells, the Mut3: Flt1(2-3)-Fc protein bound somewhat more weakly, the Mut1: Flt1(1-3_{ΔB})-Fc protein bound more weakly still, and the Mut2: Flt1(2-3_{ΔB})-Fc protein showed the best profile, binding more weakly than any of the other mutant proteins. The Mut4: Flt1(1-3_{R→N})-Fc glycosylation mutant protein showed only marginal benefit on the Matrigel assay. These results confirm the hypothesis that a linear sequence of positive amino acids can be deleted from the primary sequence resulting in a decrease in charge interaction with extracellular matrix components.

(b.) Binding of Mut1: Flt1(1-3ΔB)-Fc and Mut4: Flt1(1-3_{R→N})-Fc in a BIACORE™-Based Assay.

Unmodified and acetylated Flt1(1-3)-Fc and genetically modified Mut1: Flt1(1-3ΔB)-Fc and Mut4: Flt1(1-3_{R→N})-Fc proteins were tested in a BIACORE™-based assay to evaluate their ability to bind to the Flt1 ligand, VEGF. In this assay, unmodified Flt1(1-3)-Fc protein (0.25, 0.5, or 1.0 μg/ml) was immobilized on the surface of a BIACORE™ chip (see BIACORE™ Instruction Manual, Pharmacia, Inc., Piscataway, N.J., for standard procedures) and a solution containing 0.1 μg/ml VEGF and either purified or COS cell supernatant containing unmodified Flt1(1-3)-Fc (at approximately (0.25, 0.5, or 1.0 μg/ml), purified acetylated Flt1(1-3)-Fc (at (0.25, 0.5, or 1.0 μg/ml), COS cell supernatant containing Mut1: Flt1(1-3ΔB)-Fc. (at approximately (0.25, 0.5, or 1.0 μg/ml), or COS cell supernatant containing Mut4: Flt1(1-3_{R→N})-Fc (at approximately (0.25, 0.5, or 1.0 μg/ml) were passed over the Flt1(1-3)-Fc-coated chip. As shown in FIG. 17, at the sub-stoichiometric ratio (0.25 μg/ml Flt1(1-3)-Fc of unmodified, acetylated or genetically modified samples vs. 0.1 μg/ml VEGF), there is insufficient Flt1(1-3)-Fc protein to block binding of VEGF to the Flt1(1-3)-Fc immobilized on the BIACORE™ chip. At 0.5 μg/ml of unmodified, acetylated or genetically modified Flt1(1-3)-Fc proteins, the stoichiometric ratio approximates 1:1 and there

is an increased ability to block VEGF binding to the BIA-CORE™ chip. At 1.0 μg/ml of unmodified, acetylated or genetically modified Flt1(1-3)-Fc proteins, which is approximately a 10:1 stoichiometric ratio, the Flt1(1-3)-Fc proteins are able to block binding of VEGF to the BIA-CORE™ chip, but they are not equivalent. Unmodified, acetylated, and Mut1: Flt1(1-3ΔB)-Fc are essentially equal in their ability to block VEGF binding, whereas Mut4: Flt1(1-3_{R→N})-Fc is somewhat less efficient at blocking binding. These results confirm the hypothesis that it is possible to reduce the non-specific binding of a positively charged molecule by genetically removing a linear sequence of predominantly negatively charged amino acids.

(c.) Binding of Mut1: Flt1(1-3_{ΔB})-Fc, Mut2: Flt1(2-3_{ΔB})-Fc, Mut3: Flt1(2-3)-Fc, and in an ELISA-Based Assay.

To determine whether the three mutant proteins could bind the Flt1 ligand VEGF, binding experiments were done in which 96-well plates coated with VEGF were incubated with varying concentrations of the respective mutant protein, and after washing, the amount bound was detected by incubating with an alkaline phosphatase conjugated anti-human Fc antibody and quantitated colorimetrically by the addition of an appropriate alkaline phosphatase substrate. As shown in FIG. 19, this experiment showed that all the mutant proteins could bind VEGF similarly, at the concentrations tested.

Example 16

Pharmacokinetic Analysis of Acetylated Flt1(1-3)-Fc, Mut1: Flt1(1-3_{ΔB})-Fc, and Unmodified Flt1(1-3)-Fc

In vivo experiments were designed to assess the pharmacokinetic profiles of unmodified Flt1(1-3)-Fc, Mut1: Flt1(1-3_{ΔB})-Fc, and 40 fold molar excess acetylated Flt1(1-3)-Fc protein. Balb/c mice (25-30 g) were injected subcutaneously with 4 mg/kg of unmodified Flt1(1-3)-Fc, 40 fold molar excess acetylated Flt1(1-3)-Fc, and Mut1: Flt1(1-3_{ΔB})-Fc proteins (4 mice each). These mice were tail bled at 1, 2, 4, 6, 24 hours, 2 days, 3 days, and 5 days after injection. The sera were assayed in an ELISA designed to detect Flt1(1-3)-Fc protein which involves coating an ELISA plate with VEGF, binding the Flt1(1-3)-Fc and reporting with an anti-Fc antibody linked to alkaline phosphatase. As shown in FIG. 20, the C_{max} for these reagents was as follows: Unmodified Flt1(1-3)-Fc—0.15 μg/ml; 40 fold molar excess acetylated Flt1(1-3)-Fc—1.5 μg/ml; and Mut1: Flt1(1-3_{ΔB})-Fc—0.7 μg/ml.

Example 17

Modified Flt1 Receptor Vector Construction

The rationale for constructing modified versions of the Flt1 receptor (also known as VEGFR1) was based on the observation that the protein sequence of Flt1 was highly basic, and was therefore likely to stick to extracellular matrix (ECM). The highly basic nature of Flt1 probably explains why unmodified Flt1(1-3)-Fc (described supra) has poor pharmacokinetics that make it difficult to use as a therapeutic agent. As described supra, the chemically modified form of 40 fold molar excess acetylated Flt1(1-3)-Fc, hereinafter termed A40 exhibited a greatly improved pharmacokinetic (PK) profile over the non-acetylated Flt1(1-3)-Fc. Therefore, attempts were made to engineer DNA mol-

ecules that could be used to recombinantly express modified forms of a Flt1 receptor molecule that would possess the improved PK profile exhibited by A40 and still maintain the ability to bind tightly to VEGF.

It is known in the literature that the first Ig domain of Flt1 (which has a net charge of +5 at neutral pH) is not essential for tight binding to VEGF, so this domain was deleted. The third Ig domain (having a net charge of +11) is not essential for binding, but confers higher affinity for VEGF than the second Ig domain, so instead of deleting it entirely, it was replaced with the equivalent domains of the Flt1 receptor relatives Flk1 (also known as VEGFR2) and Flt4 (also known as VEGFR3). These chimeric molecules (denoted R1R2 (Flt1.D2.Flk1D3.FcΔC1(a) and VEGFR1R2-FcΔC1(a) and R1R3 (Flt1D2.VEGFR3D3-FcΔC1(a) and VEGFR1R3-FcΔC1(a) respectively, wherein R1 and Flk1D2=Ig domain 2 of Flt1 (VEGFR1); R2 and Flk1D3=Ig domain 3 of Flk1 (VEGFR2); and R3 and VEGFR3D3=Ig domain 3 of Flt4 (VEGFR3)) were much less sticky to ECM, as judged by an in vitro ECM binding assay as described infra, had greatly improved PK as described infra. In addition, these molecules were able to bind VEGF tightly as described infra and block phosphorylation of the native Flk1 receptor expressed in endothelial cells as described infra.

(a) Construction of the Expression Plasmid pFlt1D2.Flk1D3.FcΔC1(a)

Expression plasmids pMT21.Flt1(1-3).Fc (6519bp) and pMT21.Flk-1(1-3).Fc (5230bp) are plasmids that encode ampicillin resistance and Fc-tagged versions of Ig domains 1-3 of human Flt1 and human Flk1, respectively. These plasmids were used to construct a DNA fragment consisting of a fusion of Ig domain 2 of Flt1 with Ig domain 3 of Flk1, using PCR amplification of the respective Ig domains followed by further rounds of PCR to achieve fusion of the two domains into a single fragment. For Ig domain 2 of Flt1, the 5' and 3' amplification primers were as follows:

```
5': bsp/flt1D2
(5'-GACTAGCAGTCCGGAGGTAGACCTTTCGTAGAGATG-3')
3': Flt1D2-Flk1D3.as
(5'-CGGACTCAGAACCATCTATGATTGTTGGT-3')
```

The 5' amplification primer encodes a BspE1 restriction enzyme site upstream of Ig domain 2 of Flt1, defined by the amino acid sequence GRPFVEM (corresponding to amino acids 27-33 of FIG. 21A-21C). The 3' primer encodes the reverse complement of the 3' end of Flt1 Ig domain 2 fused directly to the 5' beginning of Flk1 Ig domain 3, with the fusion point defined as TIIID of Flt1 (corresponding to amino acids 123-126 of FIG. 21A-21C) and continuing into VVLS (corresponding to amino acids 127-130 of FIG. 21A-21C) of Flk1.

For Ig domain 3 of Flk1, the 5' and 3' amplification primers were as follows:

```
5': Flt1D2-Flk1D3.o
(5'-ACAATCATAGATGGTTCTGAGTCCGTCTCATGG-3')
3': Flk1D3/apa/srf.as
(5'-GATAATGCCCGGCCCTTTTCATGGACCCCTGACAAATG-3')
```

The 5' amplification primer encodes the end of Flt1 Ig domain 2 fused directly to the beginning of Flk1 Ig domain 3, as described above. The 3' amplification primer encodes the end of Flk1 Ig domain 3, defined by the amino acids

27

VRVHEK (corresponding to amino acids 223-228 of FIG. 21A-21C), followed by a bridging sequence that includes a recognition sequence for the restriction enzyme SrfI, and encodes the amino acids GPG. The bridging sequence corresponds to amino acids 229-231 of FIG. 21A-21C.

After a round of PCR amplification to produce the individual domains, the products were combined in a tube and subjected to a further round of PCR with the primers bsp/flt1D2 and Flk1D3/apa/srf.as (described supra) to produce the fusion product. This PCR product was subsequently digested with the restriction enzymes BspEI and SmaI and the resulting 614bp fragment was subcloned into the BspEI to SrfI restriction sites of the vector pMT21/ΔB2.Fc, to create the plasmid pMT21/Flt1D2.Flk1D3.Fc. The nucleotide sequence of the Flt1D2-Flk1D3 gene fusion insert was verified by standard sequence analysis. This plasmid was then digested with the restriction enzymes EcoRI and SrfI and the resulting 702bp fragment was transferred into the EcoRI to SrfI restriction sites of the plasmid pFlt1(1-3)B2-FcΔC1(a) to produce the plasmid pFlt1D2.Flk1D3.FcΔC1(a). The complete DNA and deduced amino acid sequences of the Flt1D2.Flk1D3.FcΔC1(a) chimeric molecule is set forth in FIG. 21A-21C.

(b) Construction of the Expression Plasmid pFlt1D2VEGFR3D3FcΔC1(a)

The expression plasmid pMT21.Flt1(1-3).Fc (6519bp) encodes ampicillin resistance and an Fc-tagged version of Ig domains 1-3 of human Flt1 receptor. This plasmid was used to produce a DNA fragment containing Ig domain 2 of Flt1 by PCR. RNA from the cell line HEL921.7 was used to produce Ig domain 3 of Flk1, using standard RT-PCR methodology. A further round of PCR amplification was used to achieve fusion of the two Ig domains into a single fused fragment. For Ig domain 2 of Flt1, the 5' and 3' amplification primers were as follows:

```
5': bsp/flt1D2
(5'-GACTAGCAGTCCGGAGGTAGACCTTCGTAGAGATG-3')
3': Flt1D2.VEGFR3D3.as
(TTCTGGGCAACAGCTGGATATCTATGATTGTATTGGT)
```

The 5' amplification primer encodes a BspEI restriction site upstream of Ig domain 2 of Flt1, defined by the amino acid sequence GRPFVEM (corresponding to amino acids 27-33 of FIG. 22A-22C). The 3' amplification primer encodes the reverse complement of the end of Flt1 Ig domain 2 fused directly to the beginning of VEGFR3 Ig domain 3, with the fusion point defined as TIID of Flt1 (corresponding to amino acids 123-126 of FIG. 22A-22C) and continuing into IQLL of VEGFR3 (corresponding to amino acids 127-130 of FIG. 22A-22C).

For Ig domain 3 of VEGFR3, the 5' and 3' primers used for RT-PCR were as follows:

```
5': R3D3.a
(ATCCAGCTGTGCCAGGAAGTCGTCGGAGCTGCTGGTA)
3': R3D3.as
(ATTTTCATGCACAATGACCTCGGTGCTCTCCGAATCG)
```

Both the 5' and 3' amplification primers match the sequence of VEGFR3. The 296bp amplification product of this RT-PCR reaction was isolated by standard techniques and subjected to a second round of PCR to add suitable sequences to allow for fusion of the Flt1D2 with the Flk1D3

28

domains and fusion of the Flk1D3 and Fc domains via a GPG bridge (see below). The amplification primers were as follows:

```
5': Flt1D2.VEGFR3D3.g
(TCATAGATATCCAGCTGTTGCCAGGAAGTCGTCGGAG)
3': VEGFR3D3/srf.as
(GATAATGCCCGGCCATTTTCATGCACAATGACCTCGGT)
```

The 5' amplification primer encodes the 3' end of Flt1 Ig domain 2 fused directly to the beginning (5' end) of VEGFR3 Ig domain 3, as described above. The 3' amplification primer encodes the 3' end of VEGFR3 Ig domain 3, defined by the amino acids VIVHEN (corresponding to amino acids 221-226 of FIG. 22A-22C), followed by a bridging sequence that includes a recognition sequence for SrfI, and encodes the amino acids GPG. The bridging sequence corresponds to amino acids 227-229 of FIG. 22A-22C.

After one round (for Flt1 Ig domain 2) or two rounds (for Flt4 Ig domain 3) of PCR to produce the individual Ig domains, the PCR products were combined in a tube and subjected to a further round of PCR amplification with the amplification primers bsp/flt1D2 and VEGFR3D3/srf.as described supra, to produce the fusion product. This PCR product was subsequently digested with the restriction enzymes BspEI and SmaI and the resulting 625bp fragment was subcloned into the BspEI to SrfI restriction sites of the vector pMT21/Flt1ΔB2.Fc (described supra), to create the plasmid pMT21/Flt1D2.VEGFR3D3.Fc. The sequence of the Flt1D2-VEGFR3D3 gene fusion insert was verified by standard sequence analysis. This plasmid was then digested with the restriction enzymes EcoRI and SrfI and the resulting 693bp fragment was subcloned into the EcoRI to SrfI restriction sites of the plasmid pFlt1(1-3)ΔB2-FcΔC1(a) to produce the plasmid designated pFlt1D2.VEGFR3D3.FcΔC1(a). The complete DNA deduced amino acid sequence of the Flt1D2.VEGFR3D3.FcΔC1(a) chimeric molecule is set forth in FIG. 22A-22C.

Example 18

Extracellular Matrix Binding (ECM) Binding Assay

ECM-coated plates (Becton Dickinson catalog # 35-4607) were rehydrated with warm DME supplemented with glutamine (2 mM), 100 U penicillin, 100 U streptomycin, and 10% BCS for at least 1 hr. before adding samples. The plates were then incubated for 1 hr. at room temperature with varying concentrations of Flt1D2.Flk1D3.FcΔC1(a) and Flt1D2.VEGFR3D3.FcΔC1(a) starting at 10 nM with subsequent 2-fold dilutions in PBS plus 10% BCS. The plates were then washed 3 times with PBS plus 0.1% Triton-X and incubated with alkaline phosphatase-conjugated anti-human Fc antibody (Promega, 1:4000 in PBS plus 10% BCS) for 1 hr. at room temperature. The plates were then washed 4 times with PBS 0.1% Triton-X and alkaline phosphatase buffer/pNPP solution (Sigma) was added for color development. Plates were read at λ=405-570 nm. The results of this experiment are shown in FIG. 23 and demonstrate that the Flt1D2.Flk1D3.FcΔC1(a) and Flt1D2.VEGFR3D3.FcΔC1(a) proteins are considerably less sticky to the ECM as compared to the Flt1(1-3)-Fc protein.

Example 19

Transient Expression of pFlt1D2.Flk1D3.FcΔC1(a)
in CHO-K1 (E1A) cells

A large scale (2 L) culture of *E. coli* DH10B cells carrying the pFlt1D2.Flk1D3.FcΔC1(a) plasmid described supra in Example 17(a) was grown overnight in Terrific Broth (TB) plus 100 μg/ml ampicillin. The next day, the plasmid DNA was extracted using a QIAGEN ENDOFREE™ Megaprep kit following the manufacturer's protocol. The concentration of the purified plasmid DNA was determined by standard techniques using a UV spectrophotometer and fluorometer. The plasmid DNA was verified by standard restriction enzyme digestion of aliquots using the restriction enzymes EcoRI plus NotI and AseI. All restriction enzyme digest fragments corresponded to the predicted sizes when analyzed on a 1% agarose gel.

Forty 15 cm petri plates were seeded with CHO-K1/E1A cells at a density of 4×10^6 cells/plate. Plating media was Gibco Ham's F-12 supplemented with 10% HYCLONETM Fetal Bovine Serum (FBS), 100 U penicillin/100 U streptomycin and glutamine (2 mM). The following day each plate of cells was transfected with 6 μg of the pFlt1D2.Flk1D3.FcΔC1(a) plasmid DNA using Gibco Opti-mem and Gibco Lipofectamine in 12 ml volume, following the manufacturer's protocol. Four hours after adding the transfection mix to the cells, 12 ml/plate of Opti-mem supplemented with 10% FBS was added. Plates were incubated at 37° C. in a 5% CO₂ incubator overnight. The following day the media was removed from each plate and 25 ml expression media (Gibco CHO-S-SFM II supplemented with glutamine (2 mM) and 1 mM sodium butyrate) was added. The plates were incubated at 37° C. for 3 days. After 3 days of incubation, the media was aspirated from each plate and centrifuged at 400 rpm in a swinging bucket rotor to pellet cells. The supernatant was decanted into sterile 1 L bottles and purification of the expressed protein was performed as described infra.

Example 20

Construction pVEGFR1R2-FcΔC1C(a) Expression
Vector

The pVEGFR1R2.FcΔC1(a) expression plasmid was constructed by insertion of DNA encoding amino acids SDT (corresponding to amino acids 27-29 of FIG. 24A-24C) between Flt1d2-Flk1d3-FcΔC1(a) amino acids 26 and 27 of FIG. 21A-21C (GG) and removal of DNA encoding amino acids GPG corresponding to amino acids 229-231 of Figure. The SDT amino acid sequence is native to the Flt1 receptor and was added back in to decrease the likelihood of heterogeneous N-terminal processing. The GPG (bridging sequence) was removed so that the Flt1 and Flk1 Ig domains were fused directly to one another. The complete DNA and deduced amino acid sequences of the pVEGFR1R2.FcΔC1(a) chimeric molecule is set forth in FIG. 24A-24C.

Example 21

Cell Culture Process Used to Produce Modified
Flt1 Receptors(a) Cell Culture Process Used to Produce
Flt1D2.Flk1D3.FcΔC1(a)

The process for production of Flt1D2.Flk1D3.FcΔC1(a) protein using the expression plasmid pFlt1D2.Flk1D3.FcΔC1(a) described supra in Example 1

involves suspension culture of recombinant Chinese hamster ovary (CHO K1/E1A) cells which constitutively express the protein product. The cells are grown in bioreactors and the protein product is isolated and purified by affinity and size exclusion chromatography. The process is provided in greater detail below.

Cell Expansion

Two confluent T-225 cm² flasks containing the Flt1D2.Flk1D3.FcΔC1(a) expressing cell line were expanded by passaging cells into eight T-225 cm² flasks in medium (GMEM +10% serum, GIBCO) and incubated at 37° C. and 5% CO₂. When the flasks approached confluence (approximately 3 to 4 days) the cells were detached using trypsin. Fresh medium was added to protect the cells from further exposure to the trypsin. The cells were centrifuged and resuspended in fresh medium then transferred to eight 850 cm² roller bottles and incubated at 37° C. and 5% CO₂ until confluent.

Suspension Culture in Bioreactors

Cells grown in roller bottles were trypsinized to detach them from the surface and washed with suspension culture medium. The cells are aseptically transferred to a 5 L bioreactor (New Brunswick Celligen Plus) where the cells are grown in 3.5 L of suspension culture. The suspension culture medium was a glutamine-free low glucose modification of IS-CHO (Irvine Scientific) to which 5% fetal bovine serum (Hyclone), GS supplement (Life Technologies) and 25 μM methionine sulfoximine (Sigma) was added. The pH was controlled at 7.2 by addition of carbon dioxide to the inlet gas or by addition of a liquid solution of sodium carbonate to the bioreactor. Dissolved oxygen level was maintained at 30% of saturation by addition of oxygen or nitrogen to the inlet gas and temperature controlled at 37° C. When a density of 4×10^6 cells/ml. was reached the cells were transferred to a 40 L bioreactor containing the same medium and setpoints for controlling the bioreactor. The temperature setpoint was reduced to 34° C. to slow cell growth and increase the relative rate of protein expression.

Cell Culture Process Used to Produce
Flt1D2.VEGFR3D3.FcΔC1(a)

The same methodologies as described supra for Flt1D2.Flk1D3.FcΔC1(a) were used to produce Flt1D2.VEGFR3D3.FcΔC1(a).

Example 22

Harvest and Purification of Modified Flt1 Receptors

(a) Harvest and Purification of Flt1D2.Flk1D3.FcΔC1(a)

The product protein was aseptically harvested from the bioreactor while retaining cells using Millipore ProstaK tangential-flow filtration modules and a low-shear mechanical pump (Fristam). Fresh medium was added to the bioreactor to replace that removed during the harvest filtration. Approximately 40 L of harvest filtrate was then loaded onto a 400 mL column containing Protein A SEPHAROSE™ resin (Amersham Pharmacia). After loading the resin was washed with buffer containing 10 mM sodium phosphate, 500 mM sodium chloride, pH 7.2 to remove any unbound contaminating proteins. Flt1D2.Flk1D3.FcΔC1(a) protein was eluted with a pH 3.0 citrate buffer. The eluted protein was neutralized by addition of Tris base and frozen at -20° C.

31

Several frozen lots of Flt1D2.Flk1D3.FcΔC1(a) protein from the Protein A step above were thawed, pooled and concentrated using a Millipore 30 kD nominal molecular weight cutoff (NMWCO) tangential flow filtration membrane. The protein was transferred to a stirred cell concentrator (Millipore) and further concentrated to 30 mg/mL using a 30 kD NMWCO membrane. The concentrated protein was loaded onto a size exclusion column packed with Superdex 200 resin (Amersham Pharmacia) that was equilibrated with phosphate buffered saline plus 5% glycerol. The same buffer was used to run the column. The fractions corresponding to Flt1D2.Flk1D3.FcΔC1(a) dimer were pooled, sterile filtered through a 0.22 micron filter, aliquoted and frozen.

(b) Harvest and Purification of Flt1D2.VEGFR3D3.FcΔC1(a)

The same methodologies as described supra for Flt1D2.Flk1D3.FcΔC1(a) were used to harvest and purify Flt1D2.VEGFR3D3.FcΔC1(a).

Example 23

Phosphorylation Assay for Transiently Expressed VEGFR2

Primary human umbilical vein endothelial cells (HU-VECs), passage 4-6, were starved for 2 hrs in serum-free DME high glucose media. Samples containing 40 ng/ml (1 nM) human VEGF165, which is a ligand for the VEGF receptors Flt1, Flk1 and Flt4(VEGFR3) were prepared and were preincubated for 1 hr. at room temperature with varying amounts of the modified Flt1 receptors Flt1(1-3)-Fc, Flt1(1-3)-Fc (A40), Flt1D2Flk1D3.FcΔC1(a) and Flt1D2VEGFR3D3.FcΔC1(a) in serum-free DME-high glucose media containing 0.1% BSA. Cells were challenged for minutes with the samples prepared above +/- VEGF165, followed by whole cell lysis using complete lysis buffer. Cell lysates were immunoprecipitated with an antibody directed against the C-terminus of VEGFR2 receptor. The immunoprecipitated lysates were loaded onto 4-12% SDS-PAGE Novex gel and then transferred to PVDF membrane using standard transfer methodologies. Detection of phosphorylated VEGFR2 was done by immunoblotting with the anti-phospho Tyrosine mAb called 4G10 (UBI) and developed using ECL-reagent (Amersham). FIGS. 25A-25C and 26A-26B show the results of this experiment. FIG. 25A-25C reveals that detection by Western blot of tyrosine phosphorylated VEGFR2(Flk1) by VEGF165 ligand stimulation shows that cell-surface receptors are phosphorylated to varying levels depending on which modified Flt1 receptor is used during the preincubations with VEGF. As is seen in FIG. 25A, at a 1.5 molar excess of either Flt1(1-3)-Fc, Flt1(1-3)-Fc (A40) or transient Flt1D2Flk1D3.FcΔC1(a) there is complete blockage of receptor stimulation by these three modified Flt1 receptors as compared to control media challenge. In contrast, transient Flt1D2VEGFR3D3.FcΔC1(a) does not show significant blockage at this molar excess, as compared with VEGF positive control challenge. Similar results are seen in FIG. 25B, where the modified Flt receptors are in a 3-fold molar excess to VEGF165 ligand. In FIG. 25C, where the modified Flt1 receptors are in a 6-fold molar excess to VEGF165 ligand, transient Flt1D2VEGFR3D3.FcΔC1(a) can now be shown to be partially blocking VEGF165-induced stimulation of cell-surface receptors.

In FIG. 26A-26B, detection by Western blot of tyrosine phosphorylated VEGFR2(Flk1) by VEGF165 ligand stimu-

32

lation shows that cell-surface receptors are not phosphorylated by challenge samples which have VEGF165 preincubated with 1 and 2 fold molar excess (FIG. 26A) or 3 and 4 fold molar excess (FIG. 26B) of either transient Flt1D2Flk1D3.FcΔC1(a), stable Flt1D2Flk1D3.FcΔC1(a), or transient VEGFR1R2-FcΔC1(a). At all modified Flt1 receptor concentrations tested there is complete binding of VEGF165 ligand during the preincubation, resulting in no detectable stimulation of cell-surface receptors by unbound VEGF165 as compared to control media challenge.

Example 24

Cell Proliferation Bioassay

The test cell population is MG87 cells that have been stably transfected with a expression plasmid that contains a DNA insert encoding the VEGFR2(Flk1) extracellular domain fused to the TrkB intracellular kinase domain, thus producing a chimeric molecule. The reason the TrkB intracellular kinase domain was used rather than the native VEGFR2(Flk1) intracellular kinase domain is that the intracellular kinase domain of VEGFR2(Flk1) does not cause a strong proliferative response when stimulated by VEGF165 in these cells. It is known that MG87 cells containing full length TrkB receptor give a robust proliferative response when stimulated with BDNF, so the TrkB intracellular kinase domain was engineered to replace the intracellular kinase domain of VEGFR2(Flk1) to take advantage of this proliferative response capability.

5×10^3 cells/well were plated in a 96 well plate and allowed to settle for 2 hrs at 37° C. The following modified Flt receptors Flt1(1-3)-Fc, Flt1D2.Flk1D3.FcΔC1(a) and Flt1D2.VEGFR3D3.FcΔC1(a), plus an irrelevant receptor termed Tie2-Fc as a negative control, were titrated from 40 nM to 20 pM and incubated on the cells for 1 hr at 37° C. Human recombinant VEGF165 in defined media was then added to all the wells at a concentration of 1.56 nM. The plates were incubated for 72 hrs at 37° C. and then MTS (Owen's reagent, Promega) added and the plates were incubated for an additional for 4 hrs. Finally, the plates were read on a spectrophotometer at 450/570 nm. The results of this experiment are shown in FIG. 27. The control receptor Tie2-Fc does not block VEGF165-induced cell proliferation at any concentration whereas Flt1D2.Flk1D3.FcΔC1(a) blocks 1.56 nM VEGF165 with a half maximal dose of 0.8 nM. Flt1(1-3)-Fc and Flt1D2.VEGFR3D3.FcΔC1(a) are less effective in blocking VEGF165 in this assay with a half maximal dose of ~2 nM. VEGF165 alone gives a reading of 1.2 absorbance units and the background is 0.38 absorbance units.

Example 25

Binding Stoichiometry of Modified Flt Receptors to VEGF165

(a) BIACORE™ Analysis

The stoichiometry of Flt1D2Flk1D3.FcΔC1(a) and VEGFR1R2-FcΔC1(a) interaction with human VEGF165 was determined by measuring either the level of VEGF saturation binding to the Flt1D2Flk1D3.FcΔC1(a) or VEGFR1R2-FcΔC1(a) surfaces or measuring concentration of VEGF165 needed to completely prevent binding of Flt1D2Flk1D3.FcΔC1(a) or VEGFR1R2-FcΔC1(a) to VEGF BIACORE™ chip surface.

Modified Flt receptors Flt1D2Flk1D3.FcΔC1(a) and VEGFR1R2-FcΔC1(a), were captured with an anti-Fc specific antibody that was first immobilized on a BIACORE™ chip using amine-coupling chemistry. A blank antibody surface was used as a negative control. VEGF165 was injected at a concentration of 1 nM, 10 nM, and 50 nM over the Flt1D2Flk1D3.FcΔC1(a) and VEGFR1R2-FcΔC1(a) surfaces at 10 μl/min for one hour. A real-time binding signal was recorded and saturation binding was achieved at the end of each injection. Binding stoichiometry was calculated as a molar ratio of bound VEGF165 to the immobilized Flt1D2Flk1D3.FcΔC1(a) or VEGFR1R2-FcΔC1(a), using the conversion factor of 1000 RU equivalent to 1 ng/ml. The results indicated binding stoichiometry of one VEGF165 dimeric molecule per one Flt1 D2Flk1 D3.FcΔC1(a) or VEGFR1R2-Fc ΔC1(a) molecule (FIG. 28).

In solution, Flt1D2Flk1D3.FcΔC1(a) or VEGFR1R2-FcΔC1(a) at a concentration of 1 nM (estimated to be 1000 times higher than the KD of the Flt1 D2Flk1 D3.FcΔC1(a) or VEGFR1 R2-FcΔC1(a)/VEGF165 interaction) were mixed with varied concentrations of VEGF165. After one hour incubation, concentrations of the free Flt1D2Flk1D3.FcΔC1(a) in solution were measured as a binding signal to an amine-coupled VEGF165 surface. A calibration curve was used to convert the Flt1D2Flk1D3.FcΔC1(a) BIACORE™ binding signal to its molar concentration. The data showed that the addition of 1 nM VEGF165 into the Flt1D2Flk1D3.FcΔC1(a) solution completely blocked Flt1D2Flk1D3.FcΔC1(a) binding to the VEGF165 surface. This result suggested the binding stoichiometry of one VEGF165 molecule per one Flt1D2Flk1D3.FcΔC1(a) molecule (FIG. 29 and FIG. 30). When the concentration of Flt1D2Flk1D3.FcΔC1(a) was plotted as a function of added concentration of VEGF165, the slope of the linear portion was 1.06 for Flt1D2Flk1D3.FcΔC1(a) and -1.07 for VEGFR1R2-FcΔC1(a). The magnitude of the slope, very close to negative one, was indicative that one molecule of VEGF165 bound to one molecule of either Flt1D2Flk1D3.FcΔC1(a) or VEGFR1R2-FcΔC1(a).

(b) Size Exclusion Chromatography

Flt1D2Flk1D3.FcΔC1(a) was mixed with a 3-fold excess of VEGF165 and the receptor-ligand complex was purified using a Pharmacia SUPEROSE™ 6 size exclusion chromatography column. The receptor-ligand complex was then incubated in a buffer containing 6M guanidine hydrochloride in order to dissociate it into its component proteins. Flt1D2Flk1D3.FcΔC1(a) was separated from VEGF165 using SUPEROSE™ 6 size exclusion chromatography column run in 6M guanidium chloride. In order to determine complex stoichiometry, several injections of Flt1D2Flk1D3.FcΔC1(a) and VEGF165 were made and peak height or peak integrated intensity was plotted as a function of the concentration of injected protein. The calibration was done under condition identical to one used in separating components of Flt1D2Flk1D3.FcΔC1(a)/VEGF complex. Quantification of the Flt1D2Flk1D3.FcΔC1(a)/VEGF complex composition was based on the calibration curves. The results of this experiment are set forth in FIG. 28, which shows the ratio of VEGF165 to Flt1D2Flk1D3.FcΔC1(a) in a complex to be 1:1.

Determination of the Binding Stoichiometry of Flt1D2Flk1D3.FcΔC1(a)/VEGF165 Complex by Size Exclusion Chromatography

Flt1D2Flk1D3.FcΔC1(a)/VEGF165 Complex Preparation

VEGF165 (concentration=3.61 mg/ml) was mixed with CHO cell transiently expressed Flt1D2.Flk1D3.FcΔC1(a) (concentration=0.9 mg/ml) in molar ratio of 3:1 (VEGF165: Flt1D2.Flk1D3.FcΔC1(a)) and incubated overnight at 4° C.

(a) Size Exclusion Chromatography (SEC) Under Native Conditions

To separate the complex from excess of unbound VEGF165, 50 μl of the complex was loaded on a Pharmacia SUPEROSE™ 12 PC 3.2/30 which was equilibrated in PBS buffer. The sample was eluted with the same buffer at flow rate 40 μl/min. at room temperature. The results of this SEC are shown in FIG. 31. Peak #1 represents the complex and peak #2 represents unbound VEGF165. Fractions eluted between 1.1 and 1.2 ml were combined and guanidinium hydrochloride (GuHCl) was added to a final concentration 4.5M to dissociate the complex.

(b) Size Exclusion Chromatography (SEC) Under Dissociative Conditions

To separate the components of the receptor-ligand complex and to determine their molar ratio, 50 μl of dissociated complex as described supra was loaded onto a SUPEROSE™ 12 PC 3.2/30 equilibrated in 6M GuHCl and eluted with the same solution at a flow rate 40 μl/min. at room temperature. The results of this SEC are shown in FIG. 32.

(c) Calculation of Flt1D2Flk1D3.FcΔC1(a):VEGF165 Complex Stoichiometry

The stoichiometry of the receptor-ligand complex was determined from the peak area or the peak height of the components. Concentrations of VEGF165 and Flt1D2Flk1D3.FcΔC1(a) corresponding to the peak height or peak area, respectively, were obtained from the standard curves for VEGF165 and Flt1D2Flk1D3.FcΔC1(a). To obtain a standard curve, four different concentrations (0.04 mg/ml -0.3 mg/ml) of either component were injected onto a Pharmacia SEPHAROSE™ 12 PC 3.2/30 column equilibrated in 6M guanidinium chloride and eluted with the same solution at flow rate 40 μl/min. at room temperature. The standard curve was obtained by plotting peak area or peak height vs protein concentration. The molar ratio of VEGF165:Flt1D2Flk1D3.FcΔC1(a) determined from the peak area of the components was 1.16. The molar ratio of VEGF165:Flt1D2Flk1D3.FcΔC1(a) determined from the peak height of the components was 1.10.

Example 27

Determination of the Stoichiometry of the Flt1D2Flk1D3.FcΔC1(a)/VEGF165 Complex by Size Exclusion Chromatography with On-Line Light Scattering

Complex Preparation

VEGF165 was mixed with CHO transiently expressed Flt1D2.Flk1D3.FcΔC1(a) protein in molar ratio of 3:1 (VEGF165:Flt1D2Flk1D3.FcΔC1(a)) and incubated overnight at 4° C.

(a) Size Exclusion Chromatography (SEC) with On-Line Light Scattering

Size exclusion chromatography column with a MiniDawn on-line light scattering detector (Wyatt Technology, Santa Barbara, Calif.) and refractive index (RI) detectors (Shimadzu, Kyoto, Japan) was used to determine the molecular weight (MW) of the receptor-ligand complex. Samples were injected onto a SUPEROSE™ 12 HR 10/30 column (Pharmacia) equilibrated in PBS buffer and eluted with the same buffer at flow rate 0.5 ml/min. at room temperature. As shown in FIG. 33, the elution profile shows two peaks. Peak #1 represents the receptor-ligand complex and peak #2 represents the unbound VEGF165. MW was calculated from LS and RI signals. The same procedure was used to determine MW of the individual components of the receptor-ligand complex. The results of these determinations are as follows: MW of the Flt1D2Flk1D3.FcΔC1(a)/VEGF-165 complex at the peak position is 157 300 (FIG. 33), the MW of VEGF165 at the peak position is 44 390 (FIG. 34) and the MW of R1R2 at the peak is 113 300 (FIG. 35).

These data indicated that the stoichiometry of the Flt1D2Flk1D3.FcΔC1(a)/VEGF complex is 1:1 as it corresponds to the sum of molecular weights for Flt1D2Flk1D3.FcΔC1(a) and VEGF165. Importantly, this method conclusively proved that the Flt1D2Flk1D3.FcΔC1(a)/VEGF165 complex was indeed composed of only one molecule of VEGF165 ligand and only one molecule of the Flt1D2Flk1D3.FcΔC1(a).

Example 28

Peptide Mapping of Flt1D2.Flk1D3.FcΔC1(a)

The disulfide structures and glycosylation sites in Flt1D2.Flk1D3.FcΔC1(a) were determined by a peptide mapping method. In this method, the protein was first cleaved with trypsin. Tryptic fragments were analyzed and identified by HPLC coupled with mass spectrometry, in addition to an N-terminal sequencing technique.

Reduction of the tryptic digest was employed to help identify disulfide-bond-containing fragments. Treatment of the tryptic digest with PNGase F (Glyko, Novato, Calif.) was employed to help identify fragments with N-linked glycosylation sites. The results are summarized in the accompanying FIG. 36.

There are a total of ten cysteines in Flt1D2.Flk1D3.FcΔC1(a); six of them belong to the Fc region. Cys27 has been confirmed to be disulfide bonded to Cys76. Cys121 is confirmed to be disulfide bonded to Cys182. The first two cysteines in the Fc region (Cys211 and Cys214) form an intermolecular disulfide bond with the same two cysteines in another Fc chain. However, because these two cysteines can not be separated enzymatically from each other, it can not be determined whether disulfide bonding is occurring between same cysteines (Cys211 to Cys211, for example) or between Cys211 and Cys214. Cys216 is confirmed to be disulfide bonded to Cys306. Cys352 is confirmed to be disulfide bonded to Cys410.

There are five possible N-linked glycosylation sites in Flt1D2.Flk1D3.FcΔC1(a). All five of them are found to be glycosylated to varying degrees. Complete glycosylation was observed at Asn33 (amino acid sequence NIT), Asn193 (amino acid sequence NST), and Asn282 (amino acid sequence NST). In addition, partial glycosylation is observed on Asn65 and Asn120. Sites of glycosylation are highlighted by underline in the FIG. 36.

Example 29

Pharmacokinetic Analysis of Modified Flt Receptors

(a) Pharmacokinetic Analysis of Flt1(1-3)-Fc (A40), Flt1D2.Flk1D3.FcΔC1(a) and VEGFR1R2-FcΔC1(a)

Balb/c mice (25-30 g) were injected subcutaneously with 4 mg/kg of Flt1(1-3)-Fc (A40), CHO transiently expressed Flt1D2.Flk1D3.FcΔC1(a), CHO stably expressed Flt1D2.Flk1D3.FcΔC1(a), and CHO transiently expressed VEGFR1R2-FcΔC1(a). The mice were tail bled at 1, 2, 4, 6, 24 hrs, 2 days, 3 days and 6 days after injection. The sera were assayed in an ELISA designed to detect Flt1(1-3)-Fc (A40), Flt1D2.Flk1D3.FcΔC1(a) or VEGFR1R2-FcΔC1(a). The ELISA involves coating an ELISA plate with VEGF165, binding the detect Flt1(1-3)-Fc (A40), Flt1D2.Flk1D3.FcΔC1(a) or VEGFR1R2-FcΔC1(a) and reporting with an anti-Fc antibody linked to horse radish peroxidase. The results of this experiments are shown in FIG. 37. The T_{max} for Flt1(1-3)-Fc (A40) was at 6 hrs while the T_{max} for the transient and stable Flt1D2.Flk1D3.FcΔC1(a) and the transient VEGFR1R2-FcΔC1(a) was 24 hrs. The C_{max} for Flt1(1-3)-Fc (A40) was 8 μg/ml. For both transients (Flt1D2.Flk1D3.FcΔC1(a) and VEGFR1R2-FcΔC1(a)) the C_{max} was 18 μg/ml and the C_{max} for the stable VEGFR1R2-FcΔC1(a) was 30 μg/ml.

(b) Pharmacokinetic Analysis of Flt1(1-3)-Fc (A40), Flt1D2.Flk1D3.FcΔC1(a) and Flt1D2.VEGFR3D3.FcΔC1(a)

Balb/c mice (25-30 g) were injected subcutaneously with 4 mg/kg of Flt1(1-3)-Fc (A40), CHO transiently expressed Flt1D2.Flk1D3.FcΔC1(a) and CHO transiently expressed Flt1D2.VEGFR3D3.FcΔC1(a). The mice were tail bled at 1, 2, 5, 6, 7, 8, 12, 15 and 20 days after injection. The sera were assayed in an ELISA designed to detect Flt1(1-3)-Fc, Flt1D2.Flk1D3.FcΔC1(a) and Flt1D2.VEGFR3D3.FcΔC1(a). The ELISA involves coating an ELISA plate with 165, binding the Flt1(1-3)-Fc, Flt1D2.Flk1D3.FcΔC1(a) or Flt1D2.VEGFR3D3.FcΔC1(a) and reporting with an anti-Fc antibody linked to horse radish peroxidase. Flt1(1-3)-Fc (A40) could no longer be detected in the serum after day 5 whereas, Flt1D2.Flk1D3.FcΔC1(a) and Flt1D2.VEGFR3D3.FcΔC1(a) were detectable for 15 days or more. The results of this experiment are shown in FIG. 38.

Example 30

Evaluation of the Ability of Flt1D2.Flk1D3.FcΔC1(a) to Inhibit Tumor Growth in Vivo

To evaluate the ability of Flt1D2.Flk1D3.FcΔC1(a) to inhibit tumor growth in vivo a model in which tumor cell suspensions are implanted subcutaneously on the right flank of male severe combined immunodeficiency (SCID) mice was employed. Two cell lines, the human HT-1080 fibrosarcoma cell line (ATCC accession no. CCL-121) and the rat C6 glioma cell line (ATCC accession no. CCL-107), each of which exhibit distinctly different morphologies and growth characteristics, were used in the assay. The first dose of Flt1D2.Flk1D3.FcΔC1(a) (at 25 mg/Kg or as indicated in FIGS. 39 and 40) was given on the day of tumor implantation. Animals subsequently received subcutaneous injections of Flt1(1-3)-Fc (A40), Flt1D2.Flk1D3.FcΔC1(a) or vehicle either every other day (EOD) or two times per week

(2x/wk) for a period of 2 weeks. After 2 weeks, animals were perfused with fixative, tumors were removed and samples were blinded. Tumor volume was determined by measuring the length and width of visible subcutaneous tumors. Both of Flt1(1-3)-Fc (A40) and Flt1D2.Flk1D3.FcΔC1(a) significantly reduced the growth of tumors formed by HT-1080 and C6 cells. The results of these experiments are shown in FIG. 39 and FIG. 40.

Example 31

The Effect of VEGF165 and Modified Flt Receptors in Female Reproductive System

The stereotypic pattern of vascular remodeling which occur in the uterus and ovary over the course of the reproductive cycle has been well characterized, making these tissues particularly well suited to the study of mechanisms which regulate angiogenesis, vascular remodeling and vascular regression. Indeed, *in situ* hybridization studies in the reproductive tissues provided the first clear evidence that VEGF acts as a mediator of physiological angiogenesis in mature rodents, as well as humans and non-human primates (Phillips et al, 1990; Ravindranath et al, 1992; Shweiki et al, 1993; Kamat et al, 1995). As cyclic angiogenesis and vascular remodeling are prominent features of the normal ovary and uterus, it is not surprising that abnormal blood vessel growth and/or vascular dysfunction have been found to characterize many pathological conditions which affect these organs. Furthermore, these pathogenic vascular abnormalities are thought to be caused or perpetuated by the dysregulated expression of one or more angiogenic or anti-angiogenic factors, most prominently VEGF.

For example, abnormal angiogenesis is characteristic of polycystic ovary disease, endometriosis and endometrial carcinoma, and in each case VEGF is over expressed in the affected tissue (Kamat et al, 1995; Shifren et al, 1996; Guidi et al, 1996; Donnez et al, 1998). Overexpression of VEGF is also thought to play a pathogenic role in the establishment of systemic vascular hyperpermeability in ovarian hyperstimulation syndrome (McClure et al, 1994; Levin et al, 1998) and preeclampsia (Baker et al, 1995; Sharkey et al, 1996). In addition, VEGF has been implicated as the permeability factor responsible for the production of ascites associated with ovarian carcinoma and other tumors (Senger et al, 1983; Boockch et al, 1995). Agents which effectively neutralize the biological actions of VEGF can reasonably be anticipated to be of therapeutic benefit in the above and related conditions.

Angiogenesis and vascular remodeling are also hallmarks of blastocyst implantation and placental development (Findlay, 1986). VEGF is strongly expressed both in the maternal decidua and in embryonic trophoblasts, where it is thought to first stimulate expansion and hyperpermeability of the uterine vasculature during the peri-implantation period and subsequently mediate formation of both the maternal and embryonic components of the placental vasculature (Shweiki et al, 1993; Cullinan-Bove and Koos, 1993; Chakraborty et al, 1995; Das et al, 1997). VEGF is also required for luteal angiogenesis and associated progesterone secretion necessary to prepare the uterus for implantation (Ferrara et al, 1998). Thus, agents which inhibit the biological actions of VEGF may prove to be useful as contraceptive agents (by preventing implantation), or as abortifacients in the early stages of gestation. The latter application might find particular use as a non-surgical intervention for the termination of ectopic pregnancies.

While the expression of VEGF receptors is largely confined to the vascular endothelium in normal reproductive tissues, Flt1 is also expressed by trophoblasts in the placenta in both humans and animals (Clark et al, 1996; He et al, 1999) where it has been proposed to play a role in trophoblast invasion. Interestingly, both Flt1 and KDR (Flk1) are expressed by choriocarcinoma cell line BeWo (Charnock-Jones et al, 1994), and VEGF has been shown to promote DNA synthesis and tyrosine phosphorylation of MAP kinase in these cells. Furthermore, primary and metastatic ovarian carcinomas not only to express high levels of VEGF, but—in addition to the vascular endothelium—the tumor cells themselves express KDR and/or Flt1 (Boockch et al, 1995). These findings suggest that VEGF may not only be critically involved in the generation and maintenance of tumor vasculature, but that at least in some tumors of reproductive origin VEGF may subserve an autocrine role, directly supporting the survival and proliferation of the tumor cells. Thus agents which block the actions of VEGF may have particularly beneficial applications to the treatment of tumors of reproductive origin.

Methods and Results

(a) Assessment of VEGF-Induced Uterine Hyperpermeability

Pregnant mare's serum gonadotrophin (PMSG) was injected subcutaneously (5 IU) to induce ovulation in prepubertal female rats. This results in a surge of estradiol after 2 days which in turn causes an induction of VEGF in the uterus. It is reported that this induction results in hyperpermeability of the uterus and an increase in uterine wet weight 6 hrs. later and, therefore, could potentially be blocked by the modified Flt receptors Flt1(1-3)-Fc (A40), Flt1D2.Flk1D3.FcΔC1(a) and Flt1D2.VEGFR3D3.FcΔC1(a). In this *in vivo* model, the normal weight of the rat uterus is about 50 mg and this can be induced to 300-350 mg by PMSG. Desiccation of the tissue reveals that this is all water weight. Subcutaneous injection of Flt1(1-3)-Fc (A40), Flt1D2.Flk1D3.FcΔC1(a) and Flt1D2.VEGFR3D3.FcΔC1(a) at 25 mg/kg at 1 hr. after PMSG injection results in about a 50% inhibition of the increase in uterine wet weight. Increasing the dose of modified Flt receptor does not further reduce the increase in wet weight suggesting that there is a VEGF-independent component to this model. The results of this experiment are shown in FIG. 41.

(a) Assessment of Corpus Luteum Angiogenesis Using Progesterone as a Readout

Pregnant mare's serum gonadotrophin (PMSG) is injected subcutaneously (5 IU) to induce ovulation in prepubertal female rats. This results in a fully functioning corpus luteum containing a dense network of blood vessels after 4 days that allows for the secretion of progesterone into the blood stream in order to prepare the uterus for implantation. The induction of angiogenesis in the corpus luteum requires VEGF; therefore, blocking VEGF would result in a lack of new blood vessels and thus a lack of progesterone secreted into the blood stream. In this *in vivo* model, resting levels of progesterone are about 5 ng/ml and this can be induced to a level of 25-40 ng/ml after PMSG. Subcutaneous injection of Flt1(1-3)-Fc (A40) or Flt1D2.Flk1D3.FcΔC1(a) at 25 mg/kg or 5 mg/kg at 1 hr. after PMSG injection results in a complete inhibition of the progesterone induction on day 4. The results of this experiment are shown in FIG. 42A-42B.

39

Example 33

Pharmacokinetic Analysis of Flt1(1-3)-Fc (A40) and Pegylated Flt1(1-3)-Fc

Flt1(1-3)-Fc was PEGylated with either 10 kD PEG or 20 kD PEG and tested in balb/c mice for their pharmacokinetic profile. Both PEGylated forms of Flt1(1-3)-Fc were found to have much better PK profiles than Flt1(1-3)-Fc (A40), with the Tmax occurring at 24 hrs. for the PEGylated molecules as opposed to 6 hrs. for Flt1(1-3)-Fc (A40).

Example 34

VEGF165 ELISA to Test Affinity of Modified Flt1 Receptor Variants

10 pM of VEGF165 was incubated overnight at room temperature with modified Flt1 receptor variants ranging from 160 pM to 0.1 pM. The modified Flt1 receptor variants used in this experiment were Flt1(1-3)-Fc, Flt1(1-3)-Fc (A40), transiently expressed Flt1D2Flk1D3.FcΔC1(a), transiently expressed Flt1D2VEFGFR3D3-FcΔC1(a), Flt1(1-

40

3_{NAS})-Fc, Flt1(1-3_{R->C})-Fc and Tie2-Fc. Flt1(1-3_{NAS})-Fc is a modified version of Flt1(1-3)-Fc in which the highly basic amino acid sequence KNKRASVRRR is replaced by NAS-VNGSR, resulting in the incorporation of two new glycosylation sites and a net reduction of five positive charges, both with the purpose of reducing the unfavorable effects of this sequence on PK. Flt1(1-3_{R->C})-Fc is a modification in which a single arginine (R) residue within the same basic amino acid sequence is changed to a cysteine (C) (KNKRASVRRR->KNKCASVRRR) to allow for pegylation at that residue, which could then shield the basic region from exerting its unfavorable effects on PK. After incubation the solution was transferred to a plate containing a capture antibody for VEGF165 (R&D). The amount of free VEGF165 was then determined using an antibody to report free VEGF165. This showed that the modified Flt1 receptor variant with the highest affinity, for VEGF165 (determined as the lowest amount of free VEGF165) was Flt1D2Flk1D3.FcΔC1(a), followed by Flt1(1-3)-Fc and Flt1(1-3)-Fc (A40) and then by Flt1(1-3_{R->C})-Fc, Flt1(1-3_{NAS})-Fc and Flt1D2VEFGFR3D3-FcΔC1(a). Tie2Fc has no affinity for VEGF165.

SEQUENCE LISTING

<160> NUMBER OF SEQ ID NOS: 38

<210> SEQ ID NO 1
 <211> LENGTH: 1704
 <212> TYPE: DNA
 <213> ORGANISM: Homo sapiens
 <220> FEATURE:
 <221> NAME/KEY: CDS
 <222> LOCATION: (1)...(1701)

<400> SEQUENCE: 1

atg gtc agc tac tgg gac acc ggg gtc ctg ctg tgc gcg ctg ctc agc	48
Met Val Ser Tyr Trp Asp Thr Gly Val Leu Leu Cys Ala Leu Leu Ser	
1 5 10 15	
tgt ctg ctt ctc aca gga tct agt tca ggt tca aaa tta aaa gat cct	96
Cys Leu Leu Thr Gly Ser Ser Ser Gly Ser Lys Leu Lys Asp Pro	
20 25 30	
gaa ctg agt tta aaa ggc acc cag cac atc atg caa gca ggc cag aca	144
Glu Leu Ser Leu Lys Gly Thr Gln His Ile Met Gln Ala Gly Gln Thr	
35 40 45	
ctg cat ctc caa tgc agg ggg gaa gca gcc cat aaa tgg tct ttg cct	192
Leu His Leu Gln Cys Arg Gly Glu Ala Ala His Lys Trp Ser Leu Pro	
50 55 60	
gaa atg gtg agt aag gaa agc gaa agg ctg agc ata act aaa tct gcc	240
Glu Met Val Ser Lys Glu Ser Glu Arg Leu Ser Ile Thr Lys Ser Ala	
65 70 75 80	
tgt gga aga aat ggc aaa caa ttc tgc agt act tta acc ttg aac aca	288
Cys Gly Arg Asn Gly Lys Gln Phe Cys Ser Thr Leu Thr Leu Asn Thr	
85 90 95	
gct caa gca aac cac act ggc ttc tac agc tgc aaa tat cta gct gta	336
Ala Gln Ala Asn His Thr Gly Phe Tyr Ser Cys Lys Tyr Leu Ala Val	
100 105 110	
cct act tca aag aag aag gaa aca gaa tct gca atc tat ata ttt att	384
Pro Thr Ser Lys Lys Lys Glu Thr Glu Ser Ala Ile Tyr Ile Phe Ile	
115 120 125	
agt gat aca ggt aga cct ttc gta gag atg tac agt gaa atc ccc gaa	432
Ser Asp Thr Gly Arg Pro Phe Val Glu Met Tyr Ser Glu Ile Pro Glu	

-continued

130	135	140	
att ata cac atg act gaa gga agg gag ctc gtc att ccc tgc cgg gtt Ile Ile His Met Thr Glu Gly Arg Glu Leu Val Ile Pro Cys Arg Val 145 150 155 160			480
acg tca cct aac atc act gtt act tta aaa aag ttt cca ctt gac act Thr Ser Pro Asn Ile Thr Val Thr Leu Lys Lys Phe Pro Leu Asp Thr 165 170 175			528
ttg atc cct gat gga aaa cgc ata atc tgg gac agt aga aag ggc ttc Leu Ile Pro Asp Gly Lys Arg Ile Ile Trp Asp Ser Arg Lys Gly Phe 180 185 190			576
atc ata tca aat gca acg tac aaa gaa ata ggg ctt ctg acc tgt gaa Ile Ile Ser Asn Ala Thr Tyr Lys Glu Ile Gly Leu Leu Thr Cys Glu 195 200 205			624
gca aca gtc aat ggg cat ttg tat aag aca aac tat ctc aca cat cga Ala Thr Val Asn Gly His Leu Tyr Lys Thr Asn Tyr Leu Thr His Arg 210 215 220			672
caa acc aat aca atc ata gat gtc caa ata agc aca cca cgc cca gtc Gln Thr Asn Thr Ile Ile Asp Val Gln Ile Ser Thr Pro Arg Pro Val 225 230 235 240			720
aaa tta ctt aga ggc cat act ctt gtc ctc aat tgt act get acc act Lys Leu Leu Arg Gly His Thr Leu Val Leu Asn Cys Thr Ala Thr Thr 245 250 255			768
ccc ttg aac acg aga gtt caa atg acc tgg agt tac cct gat gaa aaa Pro Leu Asn Thr Arg Val Gln Met Thr Trp Ser Tyr Pro Asp Glu Lys 260 265 270			816
aat aag aga gct tcc gta agg cga cga att gac caa agc aat tcc cat Asn Lys Arg Ala Ser Val Arg Arg Arg Ile Asp Gln Ser Asn Ser His 275 280 285			864
gcc aac ata ttc tac agt gtt ctt act att gac aaa atg cag aac aaa Ala Asn Ile Phe Tyr Ser Val Leu Thr Ile Asp Lys Met Gln Asn Lys 290 295 300			912
gac aaa gga ctt tat act tgt cgt gta agg agt gga cca tca ttc aaa Asp Lys Gly Leu Tyr Thr Cys Arg Val Arg Ser Gly Pro Ser Phe Lys 305 310 315 320			960
tct gtt aac acc tca gtg cat ata tat gat aaa gca ggc ccg ggc gag Ser Val Asn Thr Ser Val His Ile Tyr Asp Lys Ala Gly Pro Gly Glu 325 330 335			1008
ccc aaa tct tgt gac aaa act cac aca tgc cca ccg tgc cca gca cct Pro Lys Ser Cys Asp Lys Thr His Thr Cys Pro Pro Cys Pro Ala Pro 340 345 350			1056
gaa ctc ctg ggg gga ccg tca gtc ttc ctc ttc ccc cca aaa ccc aag Glu Leu Leu Gly Gly Pro Ser Val Phe Leu Phe Pro Pro Lys Pro Lys 355 360 365			1104
gac acc etc atg atc tcc cgg acc cct gag gtc aca tgc gtg gtg gtg Asp Thr Leu Met Ile Ser Arg Thr Pro Glu Val Thr Cys Val Val Val 370 375 380			1152
gac gtg agc cac gaa gac cct gag gtc aag ttc aac tgg tac gtg gac Asp Val Ser His Glu Asp Pro Glu Val Lys Phe Asn Trp Tyr Val Asp 385 390 395 400			1200
ggc gtg gag gtg cat aat gcc aag aca aag ccg cgg gag gag cag tac Gly Val Glu Val His Asn Ala Lys Thr Lys Pro Arg Glu Glu Gln Tyr 405 410 415			1248
aac agc acg tac cgt gtg gtc agc gtc ctc acc gtc ctg cac cag gac Asn Ser Thr Tyr Arg Val Val Ser Val Leu Thr Val Leu His Gln Asp 420 425 430			1296
tgg ctg aat ggc aag gag tac aag tgc aag gtc tcc aac aaa gcc ctc Trp Leu Asn Gly Lys Glu Tyr Lys Cys Lys Val Ser Asn Lys Ala Leu 435 440 445			1344
cca gcc ccc atc gag aaa acc atc tcc aaa gcc aaa ggg cag ccc cga			1392

-continued

Pro	Ala	Pro	Ile	Glu	Lys	Thr	Ile	Ser	Lys	Ala	Lys	Gly	Gln	Pro	Arg	
450						455					460					
gaa cca cag gtg tac acc ctg ccc cca tcc cgg gat gag ctg acc aag 1440																
Glu	Pro	Gln	Val	Tyr	Thr	Leu	Pro	Pro	Ser	Arg	Asp	Glu	Leu	Thr	Lys	
465					470					475					480	
aac cag gtc agc ctg acc tgc ctg gtc aaa ggc ttc tat ccc agc gac 1488																
Asn	Gln	Val	Ser	Leu	Thr	Cys	Leu	Val	Lys	Gly	Phe	Tyr	Pro	Ser	Asp	
				485					490					495		
atc gcc gtg gag tgg gag agc aat ggg cag ccg gag aac aac tac aag 1536																
Ile	Ala	Val	Glu	Trp	Glu	Ser	Asn	Gly	Gln	Pro	Glu	Asn	Asn	Tyr	Lys	
				500				505						510		
acc acg cct ccc gtg ctg gac tcc gac ggc tcc ttc ttc ctc tac agc 1584																
Thr	Thr	Pro	Pro	Val	Leu	Asp	Ser	Asp	Gly	Ser	Phe	Phe	Leu	Tyr	Ser	
				515				520						525		
aag ctc acc gtg gac aag agc agg tgg cag cag ggg aac gtc ttc tca 1632																
Lys	Leu	Thr	Val	Asp	Lys	Ser	Arg	Trp	Gln	Gln	Gly	Asn	Val	Phe	Ser	
				530			535				540					
tgc tcc gtg atg cat gag gct ctg cac aac cac tac acg cag aag agc 1680																
Cys	Ser	Val	Met	His	Glu	Ala	Leu	His	Asn	His	Tyr	Thr	Gln	Lys	Ser	
545					550					555					560	
ctc tcc ctg tct ccg ggt aaa tga 1704																
Leu	Ser	Leu	Ser	Pro	Gly	Lys										
						565										

<210> SEQ ID NO 2
 <211> LENGTH: 567
 <212> TYPE: PRT
 <213> ORGANISM: Homo sapiens
 <400> SEQUENCE: 2

Met	Val	Ser	Tyr	Trp	Asp	Thr	Gly	Val	Leu	Leu	Cys	Ala	Leu	Leu	Ser	
1				5					10						15	
Cys Leu Leu Leu Thr Gly Ser Ser Ser Gly Ser Lys Leu Lys Asp Pro																
				20					25					30		
Glu Leu Ser Leu Lys Gly Thr Gln His Ile Met Gln Ala Gly Gln Thr																
				35				40						45		
Leu His Leu Gln Cys Arg Gly Glu Ala Ala His Lys Trp Ser Leu Pro																
				50			55					60				
Glu Met Val Ser Lys Glu Ser Glu Arg Leu Ser Ile Thr Lys Ser Ala																
				65			70				75				80	
Cys Gly Arg Asn Gly Lys Gln Phe Cys Ser Thr Leu Thr Leu Asn Thr																
				85					90					95		
Ala Gln Ala Asn His Thr Gly Phe Tyr Ser Cys Lys Tyr Leu Ala Val																
				100					105					110		
Pro Thr Ser Lys Lys Lys Glu Thr Glu Ser Ala Ile Tyr Ile Phe Ile																
				115				120					125			
Ser Asp Thr Gly Arg Pro Phe Val Glu Met Tyr Ser Glu Ile Pro Glu																
				130			135					140				
Ile Ile His Met Thr Glu Gly Arg Glu Leu Val Ile Pro Cys Arg Val																
				145			150				155				160	
Thr Ser Pro Asn Ile Thr Val Thr Leu Lys Lys Phe Pro Leu Asp Thr																
				165					170					175		
Leu Ile Pro Asp Gly Lys Arg Ile Ile Trp Asp Ser Arg Lys Gly Phe																
				180					185					190		
Ile Ile Ser Asn Ala Thr Tyr Lys Glu Ile Gly Leu Leu Thr Cys Glu																
				195			200							205		
Ala Thr Val Asn Gly His Leu Tyr Lys Thr Asn Tyr Leu Thr His Arg																

-continued

atg gtc agc tac tgg gac acc ggg gtc ctg ctg tgc gcg ctg ctc agc Met Val Ser Tyr Trp Asp Thr Gly Val Leu Leu Cys Ala Leu Leu Ser 1 5 10 15	48
tgt ctg ctt ctc aca gga tct agt tca ggt tca aaa tta aaa gat cct Cys Leu Leu Leu Thr Gly Ser Ser Ser Gly Ser Lys Leu Lys Asp Pro 20 25 30	96
gaa ctg agt tta aaa ggc acc cag cac atc atg caa gca ggc cag aca Glu Leu Ser Leu Lys Gly Thr Gln His Ile Met Gln Ala Gly Gln Thr 35 40 45	144
ctg cat ctc caa tgc agg ggg gaa gca gcc cat aaa tgg tct ttg cct Leu His Leu Gln Cys Arg Gly Glu Ala Ala His Lys Trp Ser Leu Pro 50 55 60	192
gaa atg gtg agt aag gaa gaa agc gaa agg ctg agc ata act aaa tct gcc Glu Met Val Ser Lys Glu Ser Glu Arg Leu Ser Ile Thr Lys Ser Ala 65 70 75 80	240
tgt gga aga aat ggc aaa caa ttc tgc agt act tta acc ttg aac aca Cys Gly Arg Asn Gly Lys Gln Phe Cys Ser Thr Leu Thr Leu Asn Thr 85 90 95	288
gct caa gca aac cac act ggc ttc tac agc tgc aaa tat cta gct gta Ala Gln Ala Asn His Thr Gly Phe Tyr Ser Cys Lys Tyr Leu Ala Val 100 105 110	336
cct act tca aag aag aag gaa aca gaa tct gca atc tat ata ttt att Pro Thr Ser Lys Lys Lys Glu Thr Glu Ser Ala Ile Tyr Ile Phe Ile 115 120 125	384
agt gat aca ggt aga cct ttc gta gag atg tac agt gaa atc ccc gaa Ser Asp Thr Gly Arg Pro Phe Val Glu Met Tyr Ser Glu Ile Pro Glu 130 135 140	432
att ata cac atg act gaa gga agg gag ctc gtc att ccc tgc cgg gtt Ile Ile His Met Thr Glu Gly Arg Glu Leu Val Ile Pro Cys Arg Val 145 150 155 160	480
acg tca cct aac atc act gtt act tta aaa aag ttt cca ctt gac act Thr Ser Pro Asn Ile Thr Val Thr Leu Lys Lys Phe Pro Leu Asp Thr 165 170 175	528
ttg atc cct gat gga aaa cgc ata atc tgg gac agt aga aag ggc ttc Leu Ile Pro Asp Gly Lys Arg Ile Ile Trp Asp Ser Arg Lys Gly Phe 180 185 190	576
atc ata tca aat gca acg tac aaa gaa ata ggg ctt ctg acc tgt gaa Ile Ile Ser Asn Ala Thr Tyr Lys Glu Ile Gly Leu Leu Thr Cys Glu 195 200 205	624
gca aca gtc aat ggg cat ttg tat aag aca aac tat ctc aca cat cga Ala Thr Val Asn Gly His Leu Tyr Lys Thr Asn Tyr Leu Thr His Arg 210 215 220	672
caa acc aat aca atc ata gat gtc caa ata agc aca cca cgc cca gtc Gln Thr Asn Thr Ile Ile Asp Val Gln Ile Ser Thr Pro Arg Pro Val 225 230 235 240	720
aaa tta ctt aga ggc cat act ctt gtc ctc aat tgt act gct acc act Lys Leu Leu Arg Gly His Thr Leu Val Leu Asn Cys Thr Ala Thr Thr 245 250 255	768
ccc ttg aac acg aga gtt caa atg acc tgg agt tac cct gat gaa att Pro Leu Asn Thr Arg Val Gln Met Thr Trp Ser Tyr Pro Asp Glu Ile 260 265 270	816
gac caa agc aat tcc cat gcc aac ata ttc tac agt gtt ctt act att Asp Gln Ser Asn Ser His Ala Asn Ile Phe Tyr Ser Val Leu Thr Ile 275 280 285	864
gac aaa atg cag aac aaa gac aaa gga ctt tat act tgt cgt gta agg Asp Lys Met Gln Asn Lys Asp Lys Gly Leu Tyr Thr Cys Arg Val Arg 290 295 300	912
agt gga cca tca ttc aaa tct gtt aac acc tca gtg cat ata tat gat Ser Gly Pro Ser Phe Lys Ser Val Asn Thr Ser Val His Ile Tyr Asp 305 310 315 320	960

-continued

aaa gca ggc ccg ggc gag ccc aaa tct tgt gac aaa act cac aca tgc 1008
 Lys Ala Gly Pro Gly Glu Pro Lys Ser Cys Asp Lys Thr His Thr Cys
 325 330 335
 cca ccg tgc cca gca cct gaa ctc ctg ggg gga ccg tca gtc ttc ctc 1056
 Pro Pro Cys Pro Ala Pro Glu Leu Leu Gly Gly Pro Ser Val Phe Leu
 340 345 350
 ttc ccc cca aaa ccc aag gac acc ctc atg atc tcc cgg acc cct gag 1104
 Phe Pro Pro Lys Pro Lys Asp Thr Leu Met Ile Ser Arg Thr Pro Glu
 355 360 365
 gtc aca tgc gtg gtg gtg gac gtg agc cac gaa gac cct gag gtc aag 1152
 Val Thr Cys Val Val Val Asp Val Ser His Glu Asp Pro Glu Val Lys
 370 375 380
 ttc aac tgg tac gtg gac ggc gtg gag gtg cat aat gcc aag aca aag 1200
 Phe Asn Trp Tyr Val Asp Gly Val Glu Val His Asn Ala Lys Thr Lys
 385 390 395 400
 ccg cgg gag gag cag tac aac agc acg tac cgt gtg gtc agc gtc ctc 1248
 Pro Arg Glu Glu Gln Tyr Asn Ser Thr Tyr Arg Val Val Ser Val Leu
 405 410 415
 acc gtc ctg cac cag gac tgg ctg aat ggc aag gag tac aag tgc aag 1296
 Thr Val Leu His Gln Asp Trp Leu Asn Gly Lys Glu Tyr Lys Cys Lys
 420 425 430
 gtc tcc aac aaa gcc ctc cca gcc ccc atc gag aaa acc atc tcc aaa 1344
 Val Ser Asn Lys Ala Leu Pro Ala Pro Ile Glu Lys Thr Ile Ser Lys
 435 440 445
 gcc aaa ggg cag ccc cga gaa cca cag gtg tac acc ctg ccc cca tcc 1392
 Ala Lys Gly Gln Pro Arg Glu Pro Gln Val Tyr Thr Leu Pro Pro Ser
 450 455 460
 cgg gat gag ctg acc aag aac cag gtc agc ctg acc tgc ctg gtc aaa 1440
 Arg Asp Glu Leu Thr Lys Asn Gln Val Ser Leu Thr Cys Leu Val Lys
 465 470 475 480
 ggc ttc tat ccc agc gac atc gcc gtg gag tgg gag agc aat ggg cag 1488
 Gly Phe Tyr Pro Ser Asp Ile Ala Val Glu Trp Glu Ser Asn Gly Gln
 485 490 495
 ccg gag aac aac tac aag acc acg cct ccc gtg ctg gac tcc gac gcc 1536
 Pro Glu Asn Asn Tyr Lys Thr Thr Pro Pro Val Leu Asp Ser Asp Gly
 500 505 510
 tcc ttc ttc ctc tac agc aag ctc acc gtg gac aag agc agg tgg cag 1584
 Ser Phe Phe Leu Tyr Ser Lys Leu Thr Val Asp Lys Ser Arg Trp Gln
 515 520 525
 cag ggg aac gtc ttc tca tgc tcc gtg atg cat gag gct ctg cac aac 1632
 Gln Gly Asn Val Phe Ser Cys Ser Val Met His Glu Ala Leu His Asn
 530 535 540
 cac tac acg cag aag agc ctc tcc ctg tct ccg ggt aaa tga 1674
 His Tyr Thr Gln Lys Ser Leu Ser Leu Ser Pro Gly Lys
 545 550 555

<210> SEQ ID NO 4

<211> LENGTH: 557

<212> TYPE: PRT

<213> ORGANISM: Homo sapiens

<400> SEQUENCE: 4

Met Val Ser Tyr Trp Asp Thr Gly Val Leu Leu Cys Ala Leu Leu Ser
 1 5 10 15
 Cys Leu Leu Leu Thr Gly Ser Ser Ser Gly Ser Lys Leu Lys Asp Pro
 20 25 30
 Glu Leu Ser Leu Lys Gly Thr Gln His Ile Met Gln Ala Gly Gln Thr
 35 40 45
 Leu His Leu Gln Cys Arg Gly Glu Ala Ala His Lys Trp Ser Leu Pro

-continued

50					55					60					
Glu	Met	Val	Ser	Lys	Glu	Ser	Glu	Arg	Leu	Ser	Ile	Thr	Lys	Ser	Ala
65					70					75					80
Cys	Gly	Arg	Asn	Gly	Lys	Gln	Phe	Cys	Ser	Thr	Leu	Thr	Leu	Asn	Thr
				85					90					95	
Ala	Gln	Ala	Asn	His	Thr	Gly	Phe	Tyr	Ser	Cys	Lys	Tyr	Leu	Ala	Val
100								105					110		
Pro	Thr	Ser	Lys	Lys	Lys	Glu	Thr	Glu	Ser	Ala	Ile	Tyr	Ile	Phe	Ile
		115					120						125		
Ser	Asp	Thr	Gly	Arg	Pro	Phe	Val	Glu	Met	Tyr	Ser	Glu	Ile	Pro	Glu
130					135							140			
Ile	Ile	His	Met	Thr	Glu	Gly	Arg	Glu	Leu	Val	Ile	Pro	Cys	Arg	Val
145					150					155					160
Thr	Ser	Pro	Asn	Ile	Thr	Val	Thr	Leu	Lys	Lys	Phe	Pro	Leu	Asp	Thr
			165						170					175	
Leu	Ile	Pro	Asp	Gly	Lys	Arg	Ile	Ile	Trp	Asp	Ser	Arg	Lys	Gly	Phe
180							185						190		
Ile	Ile	Ser	Asn	Ala	Thr	Tyr	Lys	Glu	Ile	Gly	Leu	Leu	Thr	Cys	Glu
		195					200					205			
Ala	Thr	Val	Asn	Gly	His	Leu	Tyr	Lys	Thr	Asn	Tyr	Leu	Thr	His	Arg
210					215							220			
Gln	Thr	Asn	Thr	Ile	Ile	Asp	Val	Gln	Ile	Ser	Thr	Pro	Arg	Pro	Val
225					230					235					240
Lys	Leu	Leu	Arg	Gly	His	Thr	Leu	Val	Leu	Asn	Cys	Thr	Ala	Thr	Thr
			245						250					255	
Pro	Leu	Asn	Thr	Arg	Val	Gln	Met	Thr	Trp	Ser	Tyr	Pro	Asp	Glu	Ile
		260					265						270		
Asp	Gln	Ser	Asn	Ser	His	Ala	Asn	Ile	Phe	Tyr	Ser	Val	Leu	Thr	Ile
		275					280					285			
Asp	Lys	Met	Gln	Asn	Lys	Asp	Lys	Gly	Leu	Tyr	Thr	Cys	Arg	Val	Arg
290					295							300			
Ser	Gly	Pro	Ser	Phe	Lys	Ser	Val	Asn	Thr	Ser	Val	His	Ile	Tyr	Asp
305				310						315					320
Lys	Ala	Gly	Pro	Gly	Glu	Pro	Lys	Ser	Cys	Asp	Lys	Thr	His	Thr	Cys
			325						330					335	
Pro	Pro	Cys	Pro	Ala	Pro	Glu	Leu	Leu	Gly	Gly	Pro	Ser	Val	Phe	Leu
		340					345						350		
Phe	Pro	Pro	Lys	Pro	Lys	Asp	Thr	Leu	Met	Ile	Ser	Arg	Thr	Pro	Glu
		355					360					365			
Val	Thr	Cys	Val	Val	Val	Asp	Val	Ser	His	Glu	Asp	Pro	Glu	Val	Lys
370					375							380			
Phe	Asn	Trp	Tyr	Val	Asp	Gly	Val	Glu	Val	His	Asn	Ala	Lys	Thr	Lys
385				390						395					400
Pro	Arg	Glu	Glu	Gln	Tyr	Asn	Ser	Thr	Tyr	Arg	Val	Val	Ser	Val	Leu
			405						410					415	
Thr	Val	Leu	His	Gln	Asp	Trp	Leu	Asn	Gly	Lys	Glu	Tyr	Lys	Cys	Lys
		420					425						430		
Val	Ser	Asn	Lys	Ala	Leu	Pro	Ala	Pro	Ile	Glu	Lys	Thr	Ile	Ser	Lys
		435					440						445		
Ala	Lys	Gly	Gln	Pro	Arg	Glu	Pro	Gln	Val	Tyr	Thr	Leu	Pro	Pro	Ser
450					455							460			
Arg	Asp	Glu	Leu	Thr	Lys	Asn	Gln	Val	Ser	Leu	Thr	Cys	Leu	Val	Lys
465					470					475					480

-continued

```

Gly Phe Tyr Pro Ser Asp Ile Ala Val Glu Trp Glu Ser Asn Gly Gln
      485                               490           495

Pro Glu Asn Asn Tyr Lys Thr Thr Pro Pro Val Leu Asp Ser Asp Gly
      500                               505           510

Ser Phe Phe Leu Tyr Ser Lys Leu Thr Val Asp Lys Ser Arg Trp Gln
      515                               520           525

Gln Gly Asn Val Phe Ser Cys Ser Val Met His Glu Ala Leu His Asn
      530                               535           540

His Tyr Thr Gln Lys Ser Leu Ser Leu Ser Pro Gly Lys
      545                               550           555

<210> SEQ ID NO 5
<211> LENGTH: 1359
<212> TYPE: DNA
<213> ORGANISM: Homo sapiens
<220> FEATURE:
<221> NAME/KEY: CDS
<222> LOCATION: (1)...(1356)

<400> SEQUENCE: 5

atg gtc agc tac tgg gac acc ggg gtc ctg ctg tgc gcg ctg ctc agc      48
Met Val Ser Tyr Trp Asp Thr Gly Val Leu Leu Cys Ala Leu Leu Ser
  1                               5                               10           15

tgt ctg ctt ctc aca gga tct agt tcc gga ggt aga cct ttc gta gag      96
Cys Leu Leu Leu Thr Gly Ser Ser Ser Gly Gly Arg Pro Phe Val Glu
      20                               25           30

atg tac agt gaa atc ccc gaa att ata cac atg act gaa gga agg gag      144
Met Tyr Ser Glu Ile Pro Glu Ile Ile His Met Thr Glu Gly Arg Glu
      35                               40           45

ctc gtc att ccc tgc cgg gtt acg tca cct aac atc act gtt act tta      192
Leu Val Ile Pro Cys Arg Val Thr Ser Pro Asn Ile Thr Val Thr Leu
  50                               55           60

aaa aag ttt cca ctt gac act ttg atc cct gat gga aaa cgc ata atc      240
Lys Lys Phe Pro Leu Asp Thr Leu Ile Pro Asp Gly Lys Arg Ile Ile
  65                               70           75           80

tgg gac agt aga aag ggc ttc atc ata tca aat gca acg tac aaa gaa      298
Trp Asp Ser Arg Lys Gly Phe Ile Ile Ser Asn Ala Thr Tyr Lys Glu
      85                               90           95

ata ggg ctt ctg acc tgt gaa gca aca gtc aat ggg cat ttg tat aag      336
Ile Gly Leu Leu Thr Cys Glu Ala Thr Val Asn Gly His Leu Tyr Lys
      100                              105           110

aca aac tat ctc aca cat cga caa acc aat aca atc ata gat gtc caa      384
Thr Asn Tyr Leu Thr His Arg Gln Thr Asn Thr Ile Ile Asp Val Gln
      115                              120           125

ata agc aca cca cgc cca gtc aaa tta ctt aga ggc cat act ctt gtc      432
Ile Ser Thr Pro Arg Pro Val Lys Leu Leu Arg Gly His Thr Leu Val
      130                              135           140

ctc aat tgt act gct acc act ccc ttg aac acg aga gtt caa atg acc      480
Leu Asn Cys Thr Ala Thr Thr Pro Leu Asn Thr Arg Val Gln Met Thr
      145                              150           155           160

tgg agt tac cct gat gaa att gac caa agc aat tcc cat gcc aac ata      528
Trp Ser Tyr Pro Asp Glu Ile Asp Gln Ser Asn Ser His Ala Asn Ile
      165                              170           175

ttc tac agt gtt ctt act att gac aaa atg cag aac aaa gac aaa gga      576
Phe Tyr Ser Val Leu Thr Ile Asp Lys Met Gln Asn Lys Asp Lys Gly
      180                              185           190

ctt tat act tgt cgt gta agg agt gga cca tca ttc aaa tct gtt aac      624
Leu Tyr Thr Cys Arg Val Arg Ser Gly Pro Ser Phe Lys Ser Val Asn
      195                              200           205

```

-continued

```

acc tca gtg cat ata tat gat aaa gca ggc ccg ggc gag ccc aaa tct    672
Thr Ser Val His Ile Tyr Asp Lys Ala Gly Pro Gly Glu Pro Lys Ser
      210                215                220

tgt gac aaa act cac aca tgc cca ccg tgc cca gca cct gaa ctc ctg    720
Cys Asp Lys Thr His Thr Cys Pro Pro Cys Pro Ala Pro Glu Leu Leu
      225                230                235                240

ggg gga ccg tca gtc ttc ctc ttc ccc cca aaa ccc aag gac acc ctc    768
Gly Gly Pro Ser Val Phe Leu Phe Pro Pro Lys Pro Lys Asp Thr Leu
      245                250                255

atg atc tcc cgg acc cct gag gtc aca tgc gtg gtg gtg gac gtg agc    816
Met Ile Ser Arg Thr Pro Glu Val Thr Cys Val Val Val Asp Val Ser
      260                265                270

cac gaa gac cct gag gtc aag ttc aac tgg tac gtg gac ggc gtg gag    864
His Glu Asp Pro Glu Val Lys Phe Asn Trp Tyr Val Asp Gly Val Glu
      275                280                285

gtg cat aat gcc aag aca aag ccg ccg gag gag cag tac aac agc acg    912
Val His Asn Ala Lys Thr Lys Pro Arg Glu Glu Gln Tyr Asn Ser Thr
      290                295                300

tac cgt gtg gtc agc gtc ctc acc gtc ctg cac cag gac tgg ctg aat    960
Tyr Arg Val Val Ser Val Leu Thr Val Leu His Gln Asp Trp Leu Asn
      305                310                315                320

ggc aag gag tac aag tgc aag gtc tcc aac aaa gcc ctc cca gcc ccc    1008
Gly Lys Glu Tyr Lys Cys Lys Val Ser Asn Lys Ala Leu Pro Ala Pro
      325                330                335

atc gag aaa acc atc tcc aaa gcc aaa ggg cag ccc cga gaa cca cag    1056
Ile Glu Lys Thr Ile Ser Lys Ala Lys Gly Gln Pro Arg Glu Pro Gln
      340                345                350

gtg tac acc ctg ccc cca tcc cgg gat gag ctg acc aag aac cag gtc    1104
Val Tyr Thr Leu Pro Pro Ser Arg Asp Glu Leu Thr Lys Asn Gln Val
      355                360                365

agc ctg acc tgc ctg gtc aaa ggc ttc tat ccc agc gac atc gcc gtg    1152
Ser Leu Thr Cys Leu Val Lys Gly Phe Tyr Pro Ser Asp Ile Ala Val
      370                375                380

gag tgg gag agc aat ggg cag ccg gag aac aac tac aag acc acg cct    1200
Glu Trp Glu Ser Asn Gly Gln Pro Glu Asn Asn Tyr Lys Thr Thr Pro
      385                390                395                400

ccc gtg ctg gac tcc gac ggc tcc ttc ttc ctc tac agc aag ctc acc    1248
Pro Val Leu Asp Ser Asp Gly Ser Phe Phe Leu Tyr Ser Lys Leu Thr
      405                410                415

gtg gac aag agc agg tgg cag cag ggg aac gtc ttc tca tgc tcc gtg    1296
Val Asp Lys Ser Arg Trp Gln Gln Gly Asn Val Phe Ser Cys Ser Val
      420                425                430

atg cat gag gct ctg cac aac cac tac acg cag aag agc ctc tcc ctg    1344
Met His Glu Ala Leu His Asn His Tyr Thr Gln Lys Ser Leu Ser Leu
      435                440                445

tct ccg ggt aaa tga    1359
Ser Pro Gly Lys
      450

```

```

<210> SEQ ID NO 6
<211> LENGTH: 452
<212> TYPE: PRT
<213> ORGANISM: Homo sapiens
<400> SEQUENCE: 6

```

```

Met Val Ser Tyr Trp Asp Thr Gly Val Leu Leu Cys Ala Leu Leu Ser
 1          5          10          15

Cys Leu Leu Leu Thr Gly Ser Ser Ser Gly Gly Arg Pro Phe Val Glu
20          25          30

Met Tyr Ser Glu Ile Pro Glu Ile Ile His Met Thr Glu Gly Arg Glu

```

-continued

```

<210> SEQ ID NO 7
<211> LENGTH: 1389
<212> TYPE: DNA
<213> ORGANISM: Homo sapiens
<220> FEATURE:
<221> NAME/KEY: CDS
<222> LOCATION: (1)...(1386)

<400> SEQUENCE: 7

atg gtc agc tac tgg gac acc ggg gtc ctg ctg tgc gcg ctg ctc agc      48
Met Val Ser Tyr Trp Asp Thr Gly Val Leu Leu Cys Ala Leu Leu Ser
 1                               5                               10                               15

tgt ctg ctt ctc aca gga tct agt tcc gga ggt aga cct ttc gta gag      96
Cys Leu Leu Leu Thr Gly Ser Ser Ser Gly Gly Arg Pro Phe Val Glu
 20                               25                               30

atg tac agt gaa atc ccc gaa att ata cac atg act gaa gga agg gag      144
Met Tyr Ser Glu Ile Pro Glu Ile Ile His Met Thr Glu Gly Arg Glu
 35                               40                               45

ctc gtc att ccc tgc cgg gtt acg tca cct aac atc act gtt act tta      192
Leu Val Ile Pro Cys Arg Val Thr Ser Pro Asn Ile Thr Val Thr Leu
 50                               55                               60

aaa aag ttt cca ctt gac act ttg atc cct gat gga aaa cgc ata atc      240
Lys Lys Phe Pro Leu Asp Thr Leu Ile Pro Asp Gly Lys Arg Ile Ile
 65                               70                               75                               80

tgg gac agt aga aag ggc ttc atc ata tca aat gca acg tac aaa gaa      288
Trp Asp Ser Arg Lys Gly Phe Ile Ile Ser Asn Ala Thr Tyr Lys Glu
 85                               90                               95

ata ggg ctt ctg acc tgt gaa gca aca gtc aat ggg cat ttg tat aag      336
Ile Gly Leu Leu Thr Cys Glu Ala Thr Val Asn Gly His Leu Tyr Lys
100                               105                               110

aca aac tat ctc aca cat cga caa acc aat aca atc ata gat gtc caa      384
Thr Asn Tyr Leu Thr His Arg Gln Thr Asn Thr Ile Ile Asp Val Gln
115                               120                               125

ata agc aca cca cgc cca gtc aaa tta ctt aga ggc cat act ctt gtc      432
Ile Ser Thr Pro Arg Pro Val Lys Leu Leu Arg Gly His Thr Leu Val
130                               135                               140

ctc aat tgt act gct acc act ccc ttg aac acg aga gtt caa atg acc      480
Leu Asn Cys Thr Ala Thr Thr Pro Leu Asn Thr Arg Val Gln Met Thr
145                               150                               155                               160

tgg agt tac cct gat gaa aaa aat aag aga gct tcc gta agg cga cga      528
Trp Ser Tyr Pro Asp Glu Lys Asn Lys Arg Ala Ser Val Arg Arg Arg
165                               170                               175

att gac caa agc aat tcc cat gcc aac ata ttc tac agt gtt ctt act      576
Ile Asp Gln Ser Asn Ser His Ala Asn Ile Phe Tyr Ser Val Leu Thr
180                               185                               190

att gac aaa atg cag aac aaa gac aaa gga ctt tat act tgt cgt gta      624
Ile Asp Lys Met Gln Asn Lys Asp Lys Gly Leu Tyr Thr Cys Arg Val
195                               200                               205

agg agt gga cca tca ttc aaa tct gtt aac acc tca gtg cat ata tat      672
Arg Ser Gly Pro Ser Phe Lys Ser Val Asn Thr Ser Val His Ile Tyr
210                               215                               220

gat aaa gca ggc cgg ggc gag ccc aaa tct tgt gac aaa act cac aca      720
Asp Lys Ala Gly Pro Gly Glu Pro Lys Ser Cys Asp Lys Thr His Thr
225                               230                               235                               240

tgc cca ccg tgc cca gca cct gaa ctc ctg ggg gga ccg tca gtc ttc      768
Cys Pro Pro Cys Pro Ala Pro Glu Leu Leu Gly Gly Pro Ser Val Phe
245                               250                               255

ctc ttc ccc cca aaa ccc aag gac acc ctc atg atc tcc cgg acc cct      816
Leu Phe Pro Pro Lys Pro Lys Asp Thr Leu Met Ile Ser Arg Thr Pro
260                               265                               270
    
```

-continued

gag gtc aca tgc gtg gtg gac gtg agc cac gaa gac cct gag gtc 864
 Glu Val Thr Cys Val Val Val Asp Val Ser His Glu Asp Pro Glu Val
 275 280 285

aag ttc aac tgg tac gtg gac ggc gtg gag gtg cat aat gcc aag aca 912
 Lys Phe Asn Trp Tyr Val Asp Gly Val Glu Val His Asn Ala Lys Thr
 290 295 300

aag ccg cgg gag gag cag tac aac agc acg tac cgt gtg gtc agc gtc 960
 Lys Pro Arg Glu Glu Gln Tyr Asn Ser Thr Tyr Arg Val Val Ser Val
 305 310 315 320

ctc acc gtc ctg cac cag gac tgg ctg aat ggc aag gag tac aag tgc 1008
 Leu Thr Val Leu His Gln Asp Trp Leu Asn Gly Lys Glu Tyr Lys Cys
 325 330 335

aag gtc tcc aac aaa gcc ctc cca gcc ccc atc gag aaa acc atc tcc 1056
 Lys Val Ser Asn Lys Ala Leu Pro Ala Pro Ile Glu Lys Thr Ile Ser
 340 345 350

aaa gcc aaa ggg cag ccc cga gaa cca cag gtg tac acc ctg ccc cca 1104
 Lys Ala Lys Gly Gln Pro Arg Glu Pro Gln Val Tyr Thr Leu Pro Pro
 355 360 365

tcc cgg gat gag ctg acc aag aac cag gtc agc ctg acc tgc ctg gtc 1152
 Ser Arg Asp Glu Leu Thr Lys Asn Gln Val Ser Leu Thr Cys Leu Val
 370 375 380

aaa ggc ttc tat ccc agc gac atc gcc gtg gag tgg gag agc aat ggg 1200
 Lys Gly Phe Tyr Pro Ser Asp Ile Ala Val Glu Trp Glu Ser Asn Gly
 385 390 395 400

cag ccg gag aac aac tac aag acc acg cct ccc gtg ctg gac tcc gac 1248
 Gln Pro Glu Asn Asn Tyr Lys Thr Thr Pro Pro Val Leu Asp Ser Asp
 405 410 415

ggc tcc ttc ttc ctc tac agc aag ctc acc gtg gac aag agc agg tgg 1296
 Gly Ser Phe Phe Leu Tyr Ser Lys Leu Thr Val Asp Lys Ser Arg Trp
 420 425 430

cag cag ggg aac gtc ttc tca tgc tcc gtg atg cat gag gct ctg cac 1344
 Gln Gln Gly Asn Val Phe Ser Cys Ser Val Met His Glu Ala Leu His
 435 440 445

aac cac tac acg cag aag agc ctc tcc ctg tct ccg ggt aaa 1386
 Asn His Tyr Thr Gln Lys Ser Leu Ser Leu Ser Pro Gly Lys
 450 455 460

tga 1389

<210> SEQ ID NO 8
 <211> LENGTH: 462
 <212> TYPE: PRT
 <213> ORGANISM: Homo sapiens

<400> SEQUENCE: 8

Met Val Ser Tyr Trp Asp Thr Gly Val Leu Leu Cys Ala Leu Leu Ser
 1 5 10 15

Cys Leu Leu Leu Thr Gly Ser Ser Ser Gly Gly Arg Pro Phe Val Glu
 20 25 30

Met Tyr Ser Glu Ile Pro Glu Ile Ile His Met Thr Glu Gly Arg Glu
 35 40 45

Leu Val Ile Pro Cys Arg Val Thr Ser Pro Asn Ile Thr Val Thr Leu
 50 55 60

Lys Lys Phe Pro Leu Asp Thr Leu Ile Pro Asp Gly Lys Arg Ile Ile
 65 70 75 80

Trp Asp Ser Arg Lys Gly Phe Ile Ile Ser Asn Ala Thr Tyr Lys Glu
 85 90 95

Ile Gly Leu Leu Thr Cys Glu Ala Thr Val Asn Gly His Leu Tyr Lys
 100 105 110

-continued

```

Thr Asn Tyr Leu Thr His Arg Gln Thr Asn Thr Ile Ile Asp Val Gln
 115                               120                               125

Ile Ser Thr Pro Arg Pro Val Lys Leu Leu Arg Gly His Thr Leu Val
 130                               135                               140

Leu Asn Cys Thr Ala Thr Thr Pro Leu Asn Thr Arg Val Gln Met Thr
 145                               150                               155                               160

Trp Ser Tyr Pro Asp Glu Lys Asn Lys Arg Ala Ser Val Arg Arg Arg
 165                               170                               175

Ile Asp Gln Ser Asn Ser His Ala Asn Ile Phe Tyr Ser Val Leu Thr
 180                               185                               190

Ile Asp Lys Met Gln Asn Lys Asp Lys Gly Leu Tyr Thr Cys Arg Val
 195                               200                               205

Arg Ser Gly Pro Ser Phe Lys Ser Val Asn Thr Ser Val His Ile Tyr
 210                               215                               220

Asp Lys Ala Gly Pro Gly Glu Pro Lys Ser Cys Asp Lys Thr His Thr
 225                               230                               235                               240

Cys Pro Pro Cys Pro Ala Pro Glu Leu Leu Gly Gly Pro Ser Val Phe
 245                               250                               255

Leu Phe Pro Pro Lys Pro Lys Asp Thr Leu Met Ile Ser Arg Thr Pro
 260                               265                               270

Glu Val Thr Cys Val Val Val Asp Val Ser His Glu Asp Pro Glu Val
 275                               280                               285

Lys Phe Asn Trp Tyr Val Asp Gly Val Glu Val His Asn Ala Lys Thr
 290                               295                               300

Lys Pro Arg Glu Glu Gln Tyr Asn Ser Thr Tyr Arg Val Val Ser Val
 305                               310                               315                               320

Leu Thr Val Leu His Gln Asp Trp Leu Asn Gly Lys Glu Tyr Lys Cys
 325                               330                               335

Lys Val Ser Asn Lys Ala Leu Pro Ala Pro Ile Glu Lys Thr Ile Ser
 340                               345                               350

Lys Ala Lys Gly Gln Pro Arg Glu Pro Gln Val Tyr Thr Leu Pro Pro
 355                               360                               365

Ser Arg Asp Glu Leu Thr Lys Asn Gln Val Ser Leu Thr Cys Leu Val
 370                               375                               380

Lys Gly Phe Tyr Pro Ser Asp Ile Ala Val Glu Trp Glu Ser Asn Gly
 385                               390                               395                               400

Gln Pro Glu Asn Asn Tyr Lys Thr Thr Pro Pro Val Leu Asp Ser Asp
 405                               410                               415

Gly Ser Phe Phe Leu Tyr Ser Lys Leu Thr Val Asp Lys Ser Arg Trp
 420                               425                               430

Gln Gln Gly Asn Val Phe Ser Cys Ser Val Met His Glu Ala Leu His
 435                               440                               445

Asn His Tyr Thr Gln Lys Ser Leu Ser Leu Ser Pro Gly Lys
 450                               455                               460
    
```

```

<210> SEQ ID NO 9
<211> LENGTH: 1704
<212> TYPE: DNA
<213> ORGANISM: Homo sapiens
<220> FEATURE:
<221> NAME/KEY: CDS
<222> LOCATION: (1)...(1701)
    
```

<400> SEQUENCE: 9

atg gtc agc tac tgg gac acc ggg gtc ctg ctg tgc gcg ctg ctc agc

48

-continued

Met	Val	Ser	Tyr	Trp	Asp	Thr	Gly	Val	Leu	Leu	Cys	Ala	Leu	Leu	Ser	
1				5					10		r			15		
tgt	ctg	ctt	ctc	aca	gga	tct	agt	tca	ggg	tca	aaa	tta	aaa	gat	cct	96
Cys	Leu	Leu	Leu	Thr	Gly	Ser	Ser	Ser	Gly	Ser	Lys	Leu	Lys	Asp	Pro	
			20					25					30			
gaa	ctg	agt	tta	aaa	ggc	acc	cag	cac	atc	atg	caa	gca	ggc	cag	aca	144
Glu	Leu	Ser	Leu	Lys	Gly	Thr	Gln	His	Ile	Met	Gln	Ala	Gly	Gln	Thr	
		35				40						45				
ctg	cat	ctc	caa	tgc	agg	ggg	gaa	gca	gcc	cat	aaa	tgg	tct	ttg	cct	192
Leu	His	Leu	Gln	Cys	Arg	Gly	Glu	Ala	Ala	His	Lys	Trp	Ser	Leu	Pro	
	50					55					60					
gaa	atg	gtg	agt	aag	gaa	agc	gaa	agg	ctg	agc	ata	act	aaa	tct	gcc	240
Glu	Met	Val	Ser	Lys	Glu	Ser	Glu	Arg	Leu	Ser	Ile	Thr	Lys	Ser	Ala	
	65				70					75					80	
tgt	gga	aga	aat	ggc	aaa	caa	ttc	tgc	agt	act	tta	acc	ttg	aac	aca	288
Cys	Gly	Arg	Asn	Gly	Lys	Gln	Phe	Cys	Ser	Thr	Leu	Thr	Leu	Asn	Thr	
			85					90					95			
gct	caa	gca	aac	cac	act	ggc	ttc	tac	agc	tgc	aaa	tat	cta	gct	gta	336
Ala	Gln	Ala	Asn	His	Thr	Gly	Phe	Tyr	Ser	Cys	Lys	Tyr	Leu	Ala	Val	
			100					105					110			
cct	act	tca	aag	aag	aag	gaa	aca	gaa	tct	gca	atc	tat	ata	ttt	att	384
Pro	Thr	Ser	Lys	Lys	Lys	Glu	Thr	Glu	Ser	Ala	Ile	Tyr	Ile	Phe	Ile	
			115			120							125			
agt	gat	aca	ggg	aga	cct	ttc	gta	gag	atg	tac	agt	gaa	atc	ccc	gaa	432
Ser	Asp	Thr	Gly	Arg	Pro	Phe	Val	Glu	Met	Tyr	Ser	Glu	Ile	Pro	Glu	
	130				135						140					
att	ata	cac	atg	act	gaa	gga	agg	gag	ctc	gtc	att	ccc	tgc	cgg	gtt	480
Ile	Ile	His	Met	Thr	Glu	Gly	Arg	Glu	Leu	Val	Ile	Pro	Cys	Arg	Val	
	145			150					155					160		
acg	tca	cct	aac	atc	act	ggt	act	tta	aaa	aag	ttt	cca	ctt	gac	act	528
Thr	Ser	Pro	Asn	Ile	Thr	Val	Thr	Leu	Lys	Lys	Phe	Pro	Leu	Asp	Thr	
			165					170					175			
ttg	atc	cct	gat	gga	aaa	cgc	ata	atc	tgg	gac	agt	aga	aag	ggc	ttc	576
Leu	Ile	Pro	Asp	Gly	Lys	Arg	Ile	Ile	Trp	Asp	Ser	Arg	Lys	Gly	Phe	
			180					185					190			
atc	ata	tca	aat	gca	acg	tac	aaa	gaa	ata	ggg	ctt	ctg	acc	tgt	gaa	624
Ile	Ile	Ser	Asn	Ala	Thr	Tyr	Lys	Glu	Ile	Gly	Leu	Leu	Thr	Cys	Glu	
			195			200						205				
gca	aca	gtc	aat	ggg	cat	ttg	tat	aag	aca	aac	tat	ctc	aca	cat	cga	672
Ala	Thr	Val	Asn	Gly	His	Leu	Tyr	Lys	Thr	Asn	Tyr	Leu	Thr	His	Arg	
			210			215					220					
caa	acc	aat	aca	atc	ata	gat	gtc	caa	ata	agc	aca	cca	cgc	cca	gtc	720
Gln	Thr	Asn	Thr	Ile	Ile	Asp	Val	Gln	Ile	Ser	Thr	Pro	Arg	Pro	Val	
	225			230					235					240		
aaa	tta	ctt	aga	ggc	cat	act	ctt	gtc	ctc	aat	tgt	act	gct	acc	act	768
Lys	Leu	Leu	Arg	Gly	His	Thr	Leu	Val	Leu	Asn	Cys	Thr	Ala	Thr	Thr	
			245					250					255			
ccc	ttg	aac	acg	aga	ggt	caa	atg	acc	tgg	agt	tac	cct	gat	gaa	aaa	816
Pro	Leu	Asn	Thr	Arg	Val	Gln	Met	Thr	Trp	Ser	Tyr	Pro	Asp	Glu	Lys	
			260				265					270				
aat	aag	aac	gct	tcc	gta	agg	cga	cga	att	gac	caa	agc	aat	tcc	cat	864
Asn	Lys	Asn	Ala	Ser	Val	Arg	Arg	Arg	Ile	Asp	Gln	Ser	Asn	Ser	His	
		275				280						285				
gcc	aac	ata	ttc	tac	agt	ggt	ctt	act	att	gac	aaa	atg	cag	aac	aaa	912
Ala	Asn	Ile	Phe	Tyr	Ser	Val	Leu	Thr	Ile	Asp	Lys	Met	Gln	Asn	Lys	
	290				295					300						
gac	aaa	gga	ctt	tat	act	tgt	cgf	gta	agg	agt	gga	cca	tca	ttc	aaa	960
Asp	Lys	Gly	Leu	Tyr	Thr	Cys	Arg	Val	Arg	Ser	Gly	Pro	Ser	Phe	Lys	
	305			310					315					320		

-continued

tct gtt aac acc tca gtg cat ata tat gat aaa gca ggc ccg ggc gag	1008
Ser Val Asn Thr Ser Val His Ile Tyr Asp Lys Ala Gly Pro Gly Glu	
325 330 335	
ccc aaa tct tgt gac aaa act cac aca tgc cca ccg tgc cca gca cct	1056
Pro Lys Ser Cys Asp Lys Thr His Thr Cys Pro Pro Cys Pro Ala Pro	
340 345 350	
gaa ctc ctg ggg gga ccg tca gtc ttc ctc ttc ccc cca aaa ccc aag	1104
Glu Leu Leu Gly Gly Pro Ser Val Phe Leu Phe Pro Pro Lys Pro Lys	
355 360 365	
gac acc ctc atg atc tcc cgg acc cct gag gtc aca tgc gtg gtg gtg	1152
Asp Thr Leu Met Ile Ser Arg Thr Pro Glu Val Thr Cys Val Val Val	
370 375 380	
gac gtg agc cac gaa gac cct gag gtc aag ttc aac tgg tac gtg gac	1200
Asp Val Ser His Glu Asp Pro Glu Val Lys Phe Asn Trp Tyr Val Asp	
385 390 395 400	
ggc gtg gag gtg cat aat gcc aag aca aag ccg cgg gag gag cag tac	1248
Gly Val Glu Val His Asn Ala Lys Thr Lys Pro Arg Glu Glu Gln Tyr	
405 410 415	
aac agc acg tac cgt gtg gtc agc gtc ctc acc gtc ctg cac cag gac	1296
Asn Ser Thr Tyr Arg Val Val Ser Val Leu Thr Val Leu His Gln Asp	
420 425 430	
tgg ctg aat ggc aag gag tac aag tgc aag gtc tcc aac aaa gcc ctc	1344
Trp Leu Asn Gly Lys Glu Tyr Lys Cys Lys Val Ser Asn Lys Ala Leu	
435 440 445	
cca gcc ccc atc gag aaa acc atc tcc aaa gcc aaa ggg cag ccc cga	1392
Pro Ala Pro Ile Glu Lys Thr Ile Ser Lys Ala Lys Gly Gln Pro Arg	
450 455 460	
gaa cca cag gtg tac acc ctg ccc cca tcc cgg gat gag ctg acc aag	1440
Glu Pro Gln Val Tyr Thr Leu Pro Pro Ser Arg Asp Glu Leu Thr Lys	
465 470 475 480	
aac cag gtc agc ctg acc tgc ctg gtc aaa ggc ttc tat ccc agc gac	1488
Asn Gln Val Ser Leu Thr Cys Leu Val Lys Gly Phe Tyr Pro Ser Asp	
485 490 495	
atc gcc gtg gag tgg gag agc aat ggg cag ccg gag aac aac tac aag	1536
Ile Ala Val Glu Trp Glu Ser Asn Gly Gln Pro Glu Asn Asn Tyr Lys	
500 505 510	
acc acg cct ccc gtg ctg gac tcc gac ggc tcc ttc ttc ctc tac agc	1584
Thr Thr Pro Pro Val Leu Asp Ser Asp Gly Ser Phe Phe Leu Tyr Ser	
515 520 525	
aag ctc acc gtg gac aag agc agg tgg cag cag ggg aac gtc ttc tca	1632
Lys Leu Thr Val Asp Lys Ser Arg Trp Gln Gln Gly Asn Val Phe Ser	
530 535 540	
tgc tcc gtg atg cat gag gct ctg cac aac cac tac acg cag aag agc	1680
Cys Ser Val Met His Glu Ala Leu His Asn His Tyr Thr Gln Lys Ser	
545 550 555 560	
ctc tcc ctg tct ccg ggt aaa tga	1704
Leu Ser Leu Ser Pro Gly Lys	
565	

<210> SEQ ID NO 10
 <211> LENGTH: 567
 <212> TYPE: PRT
 <213> ORGANISM: Homo sapiens
 <400> SEQUENCE: 10

Met Val Ser Tyr Trp Asp Thr Gly Val Leu Leu Cys Ala Leu Leu Ser
1 5 10 15
Cys Leu Leu Leu Thr Gly Ser Ser Ser Gly Ser Lys Leu Lys Asp Pro
20 25 30
Glu Leu Ser Leu Lys Gly Thr Gln His Ile Met Gln Ala Gly Gln Thr

-continued

35			40			45																	
Leu	His	50	Leu	Gln	55	Cys	Arg	60	Gly	Glu	65	Ala	Ala	70	His	Lys	75	Trp	Ser	80	Leu	Pro	85
Glu	Met	65	Val	Ser	70	Lys	Glu	75	Ser	Glu	80	Arg	Leu	85	Ser	Ile	90	Thr	Lys	95	Ser	Ala	100
Cys	Gly	85	Arg	Asn	90	Gly	Lys	95	Gln	Phe	100	Cys	Ser	105	Thr	Leu	110	Thr	Leu	115	Asn	Thr	120
Ala	Gln	100	Ala	Asn	105	His	Thr	110	Gly	Phe	115	Tyr	Ser	120	Cys	Lys	125	Tyr	Leu	130	Ala	Val	135
Pro	Thr	115	Ser	Lys	120	Lys	Glu	125	Thr	Glu	130	Ser	Ala	135	Ile	Tyr	140	Ile	Phe	145	Ile	Pro	150
Ser	Asp	130	Thr	Gly	135	Arg	Pro	140	Phe	Val	145	Glu	Met	150	Tyr	Ser	155	Glu	Ile	160	Pro	Glu	165
Ile	Ile	145	His	Met	150	Thr	Glu	155	Gly	Arg	160	Glu	Leu	165	Val	Ile	170	Pro	Cys	175	Arg	Val	180
Thr	Ser	165	Pro	Asn	170	Ile	Thr	175	Val	Thr	180	Leu	Lys	185	Lys	Phe	190	Pro	Leu	195	Asp	Thr	200
Leu	Ile	180	Pro	Asp	185	Gly	Lys	190	Arg	Ile	195	Ile	Trp	200	Asp	Ser	205	Arg	Lys	210	Gly	Phe	215
Ile	Ile	195	Ser	Asn	200	Ala	Thr	205	Tyr	Lys	210	Glu	Ile	215	Gly	Leu	220	Leu	Thr	225	Cys	Glu	230
Ala	Thr	210	Val	Asn	215	Gly	His	220	Leu	Tyr	225	Lys	Thr	230	Asn	Tyr	235	Leu	Thr	240	His	Arg	245
Gln	Thr	225	Asn	Thr	230	Ile	Ile	235	Asp	Val	240	Gln	Ile	245	Ser	Thr	250	Pro	Arg	255	Pro	Val	260
Lys	Leu	245	Leu	Arg	250	Gly	His	255	Thr	Leu	260	Val	Leu	265	Asn	Cys	270	Thr	Ala	275	Thr	Thr	280
Pro	Leu	260	Asn	Thr	265	Arg	Val	270	Gln	Met	275	Thr	Trp	280	Ser	Tyr	285	Pro	Asp	290	Glu	Lys	295
Asn	Lys	275	Asn	Ala	280	Ser	Val	285	Arg	Arg	290	Arg	Ile	295	Asp	Gln	300	Ser	Asn	305	Ser	His	310
Ala	Asn	290	Ile	Phe	295	Tyr	Ser	300	Val	Leu	305	Thr	Ile	310	Asp	Lys	315	Met	Gln	320	Asn	Lys	325
Asp	Lys	305	Gly	Leu	310	Tyr	Thr	315	Cys	Arg	320	Val	Arg	325	Ser	Gly	330	Pro	Ser	335	Phe	Lys	340
Ser	Val	325	Asn	Thr	330	Ser	Val	335	His	Ile	340	Tyr	Asp	345	Lys	Ala	350	Gly	Pro	355	Gly	Glu	360
Pro	Lys	340	Ser	Cys	345	Asp	Lys	350	Thr	His	355	Thr	Cys	360	Pro	Pro	365	Cys	Pro	370	Ala	Pro	375
Glu	Leu	355	Leu	Gly	360	Gly	Pro	365	Ser	Val	370	Phe	Leu	375	Pro	Pro	380	Lys	Pro	385	Lys	Lys	390
Asp	Thr	370	Leu	Met	375	Ile	Ser	380	Arg	Thr	385	Pro	Glu	390	Val	Thr	395	Cys	Val	400	Val	Val	405
Asp	Val	385	Ser	His	390	Glu	Asp	395	Pro	Glu	400	Val	Lys	405	Phe	Asn	410	Trp	Tyr	415	Val	Asp	420
Gly	Val	405	Glu	Val	410	His	Asn	415	Ala	Lys	420	Thr	Lys	425	Pro	Arg	430	Glu	Glu	435	Gln	Tyr	440
Asn	Ser	420	Thr	Tyr	425	Arg	Val	430	Val	Ser	435	Val	Leu	440	Thr	Val	445	Leu	His	450	Gln	Asp	455
Trp	Leu	435	Asn	Gly	440	Lys	Glu	445	Tyr	Lys	450	Cys	Lys	455	Val	Ser	460	Asn	Lys	465	Ala	Leu	470
Pro	Ala	450	Pro	Ile	455	Glu	Lys	460	Thr	Ile	465	Ser	Lys	470	Ala	Lys	475	Gly	Gln	480	Pro	Arg	485

-continued

Glu Pro Gln Val Tyr Thr Leu Pro Pro Ser Arg Asp Glu Leu Thr Lys
 465 470 475 480
 Asn Gln Val Ser Leu Thr Cys Leu Val Lys Gly Phe Tyr Pro Ser Asp
 485 490 495
 Ile Ala Val Glu Trp Glu Ser Asn Gly Gln Pro Glu Asn Asn Tyr Lys
 500 505 510
 Thr Thr Pro Pro Val Leu Asp Ser Asp Gly Ser Phe Phe Leu Tyr Ser
 515 520 525
 Lys Leu Thr Val Asp Lys Ser Arg Trp Gln Gln Gly Asn Val Phe Ser
 530 535 540
 Cys Ser Val Met His Glu Ala Leu His Asn His Tyr Thr Gln Lys Ser
 545 550 555 560
 Leu Ser Leu Ser Pro Gly Lys
 565

<210> SEQ ID NO 11
 <211> LENGTH: 1453
 <212> TYPE: DNA
 <213> ORGANISM: Homo sapiens
 <220> FEATURE:
 <221> NAME/KEY: CDS
 <222> LOCATION: (69)...(1442)

<400> SEQUENCE: 11

aagcttgggc tgcaggtcga tcgactctag aggatcgatc cccgggagag ctcgattcg 60
 caaccacc atg gtc agc tac tgg gac acc ggg gtc ctg ctg tgc gcg ctg 110
 Met Val Ser Tyr Trp Asp Thr Gly Val Leu Leu Cys Ala Leu
 1 5 10
 ctc agc tgt ctg ctt ctc aca gga tct agt tcc gga ggt aga cct ttc 158
 Leu Ser Cys Leu Leu Leu Thr Gly Ser Ser Ser Gly Gly Arg Pro Phe
 15 20 25 30
 gta gag atg tac agt gaa atc ccc gaa att ata cac atg act gaa gga 206
 Val Glu Met Tyr Ser Glu Ile Pro Glu Ile Ile His Met Thr Glu Gly
 35 40 45
 agg gag ctc gtc att ccc tgc cgg gtt acg tca cct aac atc act gtt 254
 Arg Glu Leu Val Ile Pro Cys Arg Val Thr Ser Pro Asn Ile Thr Val
 50 55 60
 act tta aaa aag ttt cca ctt gac act ttg atc cct gat gga aaa cgc 302
 Thr Leu Lys Lys Phe Pro Leu Asp Thr Leu Ile Pro Asp Gly Lys Arg
 65 70 75
 ata atc tgg gac agt aga aag ggc ttc atc ata tca aat gca acg tac 350
 Ile Ile Trp Asp Ser Arg Lys Gly Phe Ile Ile Ser Asn Ala Thr Tyr
 80 85 90
 aaa gaa ata ggg ctt ctg acc tgt gaa gca aca gtc aat ggg cat ttg 398
 Lys Glu Ile Gly Leu Leu Thr Cys Glu Ala Thr Val Asn Gly His Leu
 95 100 105 110
 tat aag aca aac tat ctc aca cat cga caa acc aat aca atc ata gat 446
 Tyr Lys Thr Asn Tyr Leu Thr His Arg Gln Thr Asn Thr Ile Ile Asp
 115 120 125
 gtg gtt ctg agt ccg tct cat gga att gaa cta tct gtt gga gaa aag 494
 Val Val Leu Ser Pro Ser His Gly Ile Glu Leu Ser Val Gly Glu Lys
 130 135 140
 ctt gtc tta aat tgt aca gca aga act gaa cta aat gtg ggg att gac 542
 Leu Val Leu Asn Cys Thr Ala Arg Thr Glu Leu Asn Val Gly Ile Asp
 145 150 155
 ttc aac tgg gaa tac cct tct tgg aag cat cag cat aag aaa ctt gta 590
 Phe Asn Trp Glu Tyr Pro Ser Ser Lys His Gln His Lys Lys Leu Val
 160 165 170

-continued

aac cga gac cta aaa acc cag tct ggg agt gag atg aag aaa ttt ttg Aen Arg Asp Leu Lys Thr Gln Ser Gly Ser Glu Met Lys Lys Phe Leu 175 180 185 190	638
agc acc tta act ata gat ggt gta acc cgg agt gac caa gga ttg tac Ser Thr Leu Thr Ile Asp Gly Val Thr Arg Ser Asp Gln Gly Leu Tyr 195 200 205	686
acc tgt gca gca tcc agt ggg ctg atg acc aag aag aac agc aca ttt Thr Cys Ala Ala Ser Ser Gly Leu Met Thr Lys Lys Aen Ser Thr Phe 210 215 220	734
gtc agg gtc cat gaa aag ggc ccg ggc gac aaa act cac aca tgc cca Val Arg Val His Glu Lys Gly Pro Gly Asp Lys Thr His Thr Cys Pro 225 230 235	782
ccg tgc cca gca cct gaa ctc ctg ggg gga ccg tca gtc ttc ctc ttc Pro Cys Pro Ala Pro Glu Leu Leu Gly Gly Pro Ser Val Phe Leu Phe 240 245 250	830
ccc cca aaa ccc aag gac acc ctc atg atc tcc cgg acc cct gag gtc Pro Pro Lys Pro Lys Asp Thr Leu Met Ile Ser Arg Thr Pro Glu Val 255 260 265 270	878
aca tgc gtg gtg gtg gac gtg agc cac gaa gac cct gag gtc aag ttc Thr Cys Val Val Val Asp Val Ser His Glu Asp Pro Glu Val Lys Phe 275 280 285	926
aac tgg tac gtg gac ggc gtg gag gtg cat aat gcc aag aca aag ccg Aen Trp Tyr Val Asp Gly Val Glu Val His Aen Ala Lys Thr Lys Pro 290 295 300	974
cgg gag gag cag tac aac agc acg tac cgt gtg gtc agc gtc ctc acc Arg Glu Glu Gln Tyr Aen Ser Thr Tyr Arg Val Val Ser Val Leu Thr 305 310 315	1022
gtc ctg cac cag gac tgg ctg aat ggc aag gag tac aag tgc aag gtc Val Leu His Gln Asp Trp Leu Aen Gly Lys Glu Tyr Lys Cys Lys Val 320 325 330	1070
tcc aac aaa gcc ctc cca gcc ccc atc gag aaa acc atc tcc aaa gcc Ser Aen Lys Ala Leu Pro Ala Pro Ile Glu Lys Thr Ile Ser Lys Ala 335 340 345 350	1118
aaa ggg cag ccc cga gaa cca cag gtg tac acc ctg ccc cca tcc cgg Lys Gly Gln Pro Arg Glu Pro Gln Val Tyr Thr Leu Pro Pro Ser Arg 355 360 365	1166
gat gag ctg acc aag aac cag gtc agc ctg acc tgc ctg gtc aaa ggc Asp Glu Leu Thr Lys Aen Gln Val Ser Leu Thr Cys Leu Val Lys Gly 370 375 380	1214
ttc tat ccc agc gac atc gcc gtg gag tgg gag agc aat ggg cag ccg Phe Tyr Pro Ser Asp Ile Ala Val Glu Trp Glu Ser Aen Gly Gln Pro 385 390 395	1262
gag aac aac tac aag acc acg cct ccc gtg ctg gac tcc gac ggc tcc Glu Aen Aen Tyr Lys Thr Thr Pro Pro Val Leu Asp Ser Asp Gly Ser 400 405 410	1310
ttc ttc ctc tat agc aag ctc acc gtg gac aag agc agg tgg cag cag Phe Phe Leu Tyr Ser Lys Leu Thr Val Asp Lys Ser Arg Trp Gln Gln 415 420 425 430	1358
ggg aac gtc ttc tca tgc tcc gtg atg cat gag gct ctg cac aac cac Gly Aen Val Phe Ser Cys Ser Val Met His Glu Ala Leu His Aen His 435 440 445	1406
tac acg cag aag agc ctc tcc ctg tct ccg ggt aaa tgagcgccg Tyr Thr Gln Lys Ser Leu Ser Leu Ser Pro Gly Lys 450 455	1452
c	1453

<210> SEQ ID NO 12
 <211> LENGTH: 458
 <212> TYPE: PRT
 <213> ORGANISM: Homo sapiens

-continued

<400> SEQUENCE: 12

Met Val Ser Tyr Trp Asp Thr Gly Val Leu Leu Cys Ala Leu Leu Ser
 1 5 10 15
 Cys Leu Leu Leu Thr Gly Ser Ser Ser Gly Gly Arg Pro Phe Val Glu
 20 25 30
 Met Tyr Ser Glu Ile Pro Glu Ile Ile His Met Thr Glu Gly Arg Glu
 35 40 45
 Leu Val Ile Pro Cys Arg Val Thr Ser Pro Asn Ile Thr Val Thr Leu
 50 55 60
 Lys Lys Phe Pro Leu Asp Thr Leu Ile Pro Asp Gly Lys Arg Ile Ile
 65 70 75 80
 Trp Asp Ser Arg Lys Gly Phe Ile Ile Ser Asn Ala Thr Tyr Lys Glu
 85 90 95
 Ile Gly Leu Leu Thr Cys Glu Ala Thr Val Asn Gly His Leu Tyr Lys
 100 105 110
 Thr Asn Tyr Leu Thr His Arg Gln Thr Asn Thr Ile Ile Asp Val Val
 115 120 125
 Leu Ser Pro Ser His Gly Ile Glu Leu Ser Val Gly Glu Lys Leu Val
 130 135 140
 Leu Asn Cys Thr Ala Arg Thr Glu Leu Asn Val Gly Ile Asp Phe Asn
 145 150 155 160
 Trp Glu Tyr Pro Ser Ser Lys His Gln His Lys Lys Leu Val Asn Arg
 165 170 175
 Asp Leu Lys Thr Gln Ser Gly Ser Glu Met Lys Lys Phe Leu Ser Thr
 180 185 190
 Leu Thr Ile Asp Gly Val Thr Arg Ser Asp Gln Gly Leu Tyr Thr Cys
 195 200 205
 Ala Ala Ser Ser Gly Leu Met Thr Lys Lys Asn Ser Thr Phe Val Arg
 210 215 220
 Val His Glu Lys Gly Pro Gly Asp Lys Thr His Thr Cys Pro Pro Cys
 225 230 235 240
 Pro Ala Pro Glu Leu Leu Gly Gly Pro Ser Val Phe Leu Phe Pro Pro
 245 250 255
 Lys Pro Lys Asp Thr Leu Met Ile Ser Arg Thr Pro Glu Val Thr Cys
 260 265 270
 Val Val Val Asp Val Ser His Glu Asp Pro Glu Val Lys Phe Asn Trp
 275 280 285
 Tyr Val Asp Gly Val Glu Val His Asn Ala Lys Thr Lys Pro Arg Glu
 290 295 300
 Glu Gln Tyr Asn Ser Thr Tyr Arg Val Val Ser Val Leu Thr Val Leu
 305 310 315 320
 His Gln Asp Trp Leu Asn Gly Lys Glu Tyr Lys Cys Lys Val Ser Asn
 325 330 335
 Lys Ala Leu Pro Ala Pro Ile Glu Lys Thr Ile Ser Lys Ala Lys Gly
 340 345 350
 Gln Pro Arg Glu Pro Gln Val Tyr Thr Leu Pro Pro Ser Arg Asp Glu
 355 360 365
 Leu Thr Lys Asn Gln Val Ser Leu Thr Cys Leu Val Lys Gly Phe Tyr
 370 375 380
 Pro Ser Asp Ile Ala Val Glu Trp Glu Ser Asn Gly Gln Pro Glu Asn
 385 390 395 400
 Asn Tyr Lys Thr Thr Pro Pro Val Leu Asp Ser Asp Gly Ser Phe Phe

-continued

	405	410	415	
Leu Tyr Ser Lys Leu Thr Val Asp Lys Ser Arg Trp Gln Gln Gly Asn	420	425	430	
Val Phe Ser Cys Ser Val Met His Glu Ala Leu His Asn His Tyr Thr	435	440	445	
Gln Lys Ser Leu Ser Leu Ser Pro Gly Lys	450	455		
<210> SEQ ID NO 13				
<211> LENGTH: 1444				
<212> TYPE: DNA				
<213> ORGANISM: Homo sapiens				
<220> FEATURE:				
<221> NAME/KEY: CDS				
<222> LOCATION: (69)...(1433)				
<400> SEQUENCE: 13				
aagcttgggc tgcaggtcga tcgactctag aggatcgatc cccgggag ctcgaattcg				60
caaccacc atg gtc agc tac tgg gac acc ggg gtc ctg ctg tgc gcg ctg				110
Met Val Ser Tyr Trp Asp Thr Gly Val Leu Leu Cys Ala Leu	1	5	10	
ctc agc tgt ctg ctt ctc aca gga tct agt tcc gga ggt aga cct ttc				158
Leu Ser Cys Leu Leu Thr Gly Ser Ser Ser Gly Gly Arg Pro Phe	15	20	25	30
gta gag atg tac agt gaa atc ccc gaa att ata cac atg act gaa gga				206
Val Glu Met Tyr Ser Glu Ile Pro Glu Ile Ile His Met Thr Glu Gly	35	40	45	
agg gag ctc gtc att ccc tgc cgg gtt acg tca cct aac atc act gtt				254
Arg Glu Leu Val Ile Pro Cys Arg Val Thr Ser Pro Asn Ile Thr Val	50	55	60	
act tta aaa aag ttt cca ctt gac act ttg atc cct gat gga aaa cgc				302
Thr Leu Lys Lys Phe Pro Leu Asp Thr Leu Ile Pro Asp Gly Lys Arg	65	70	75	
ata atc tgg gac agt aga aag ggc ttc atc ata tca aat gca acg tac				350
Ile Ile Trp Asp Ser Arg Lys Gly Phe Ile Ile Ser Asn Ala Thr Tyr	80	85	90	
aaa gaa ata ggg ctt ctg acc tgt gaa gca aca gtc aat ggg cat ttg				398
Lys Glu Ile Gly Leu Leu Thr Cys Glu Ala Thr Val Asn Gly His Leu	95	100	105	110
tat aag aca aac tat ctc aca cat cga caa acc aat aca atc ata gat				446
Tyr Lys Thr Asn Tyr Leu Thr His Arg Gln Thr Asn Thr Ile Ile Asp	115	120	125	
atc cag ctg ttg ccc agg aag tgc ctg gag ctg ctg gta ggg gag aag				494
Ile Gln Leu Leu Pro Arg Lys Ser Leu Glu Leu Leu Val Gly Glu Lys	130	135	140	
ctg gtc ctc aac tgc acc gtg tgg gct gag ttt aac tca ggt gtc acc				542
Leu Val Leu Asn Cys Thr Val Trp Ala Glu Phe Asn Ser Gly Val Thr	145	150	155	
ttt gac tgg gac tac cca ggg aag cag gca gag cgg ggt aag tgg gtg				590
Phe Asp Trp Asp Tyr Pro Gly Lys Gln Ala Glu Arg Gly Lys Trp Val	160	165	170	
ccc gag cga cgc tcc caa cag acc cac aca gaa ctc tcc agc atc ctg				638
Pro Glu Arg Arg Ser Gln Gln Thr His Thr Glu Leu Ser Ser Ile Leu	175	180	185	190
acc atc cac aac gtc agc cag cac gac ctg ggc tgc tat gtg tgc aag				686
Thr Ile His Asn Val Ser Gln His Asp Leu Gly Ser Tyr Val Cys Lys	195	200	205	
gcc aac aac ggc atc cag cga ttt cgg gag agc acc gag gtc att gtg				734
Ala Asn Asn Gly Ile Gln Arg Phe Arg Glu Ser Thr Glu Val Ile Val	210	215	220	

-continued

```

cat gaa aat ggc ccg ggc gac aaa act cac aca tgc cca ccg tgc cca      782
His Glu Asn Gly Pro Gly Asp Lys Thr His Thr Cys Pro Pro Cys Pro
      225                               230                               235

gca cct gaa ctc ctg ggg gga ccg tca gtc ttc ctc ttc ccc cca aaa      830
Ala Pro Glu Leu Leu Gly Gly Pro Ser Val Phe Leu Phe Pro Pro Lys
      240                               245                               250

ccc aag gac acc ctc atg atc tcc cgg acc cct gag gtc aca tgc gtg      878
Pro Lys Asp Thr Leu Met Ile Ser Arg Thr Pro Glu Val Thr Cys Val
      255                               260                               265                               270

gtg gtg gac gtg agc cac gaa gac cct gag gtc aag ttc aac tgg tac      926
Val Val Asp Val Ser His Glu Asp Pro Glu Val Lys Phe Asn Trp Tyr
      275                               280                               285

gtg gac ggc gtg gag gtg cat aat gcc aag aca aag ccg cgg gag gag      974
Val Asp Gly Val Glu Val His Asn Ala Lys Thr Lys Pro Arg Glu Glu
      290                               295                               300

cag tac aac agc acg tac cgt gtg gtc agc gtc ctc acc gtc ctg cac      1022
Gln Tyr Asn Ser Thr Tyr Arg Val Val Ser Val Leu Thr Val Leu His
      305                               310                               315

cag gac tgg ctg aat ggc aag gag tac aag tgc aag gtc tcc aac aaa      1070
Gln Asp Trp Leu Asn Gly Lys Glu Tyr Lys Cys Lys Val Ser Asn Lys
      320                               325                               330

gcc ctc cca gcc ccc atc gag aaa acc atc tcc aaa gcc aaa ggg cag      1118
Ala Leu Pro Ala Pro Ile Glu Lys Thr Ile Ser Lys Ala Lys Gly Gln
      335                               340                               345                               350

ccc cga gaa cca cag gtg tac acc ctg ccc cca tcc cgg gat gag ctg      1166
Pro Arg Glu Pro Gln Val Tyr Thr Leu Pro Pro Ser Arg Asp Glu Leu
      355                               360                               365

acc aag aac cag gtc agc ctg acc tgc ctg gtc aaa ggc ttc tat ccc      1214
Thr Lys Asn Gln Val Ser Leu Thr Cys Leu Val Lys Gly Phe Tyr Pro
      370                               375                               380

agc gac atc gcc gtg gag tgg gag agc aat ggg cag ccg gag aac aac      1262
Ser Asp Ile Ala Val Glu Trp Glu Ser Asn Gly Gln Pro Glu Asn Asn
      385                               390                               395

tac aag acc acg cct ccc gtg ctg gac tcc gac gcc tcc ttc ttc ctc      1310
Tyr Lys Thr Thr Pro Pro Val Leu Asp Ser Asp Gly Ser Phe Phe Leu
      400                               405                               410

tat agc aag ctc acc gtg gac aag agc agg tgg cag cag ggg aac gtc      1358
Tyr Ser Lys Leu Thr Val Asp Lys Ser Arg Trp Gln Gln Gly Asn Val
      415                               420                               425                               430

ttc tca tgc tcc gtg atg cat gag gct ctg cac aac cac tac acg cag      1406
Phe Ser Cys Ser Val Met His Glu Ala Leu His Asn His Tyr Thr Gln
      435                               440                               445

aag agc ctc tcc ctg tct cgg ggt aaa tgagcggccg c      1444
Lys Ser Leu Ser Leu Ser Pro Gly Lys
      450                               455
    
```

```

<210> SEQ ID NO 14
<211> LENGTH: 455
<212> TYPE: PRT
<213> ORGANISM: Homo sapiens
    
```

<400> SEQUENCE: 14

```

Met Val Ser Tyr Trp Asp Thr Gly Val Leu Leu Cys Ala Leu Leu Ser
 1          5          10          15

Cys Leu Leu Leu Thr Gly Ser Ser Ser Gly Gly Arg Pro Phe Val Glu
 20          25          30

Met Tyr Ser Glu Ile Pro Glu Ile Ile His Met Thr Glu Gly Arg Glu
 35          40          45

Leu Val Ile Pro Cys Arg Val Thr Ser Pro Asn Ile Thr Val Thr Leu
    
```

-continued

50	55	60
Lys 65	Lys Phe Pro Leu Asp Thr 70	Leu Ile Pro Asp Gly Lys Arg Ile Ile 80
Trp 85	Asp Ser Arg Lys Gly Phe Ile Ile 90	Ser Asn Ala Thr Tyr Lys Glu 95
Ile 100	Gly Leu Leu Thr Cys Glu Ala Thr 105	Val Asn Gly His Leu Tyr Lys 110
Thr 115	Asn Tyr Leu Thr His Arg Gln Thr 120	Asn Thr Ile Ile Asp Ile Gln 125
Leu 130	Leu Pro Arg Lys Ser Leu Glu Leu Leu Val 135	Gly Glu Lys Leu Val 140
Leu 145	Asn Cys Thr Val Trp Ala Glu Phe Asn Ser 150	Gly Val Thr Phe Asp 155 160
Trp 165	Asp Tyr Pro Gly Lys Gln Ala Glu Arg Gly 170	Lys Trp Val Pro Glu 175
Arg 180	Arg Ser Gln Gln Thr His Thr Glu Leu Ser 185	Ser Ile Leu Thr Ile 190
His 195	Asn Val Ser Gln His Asp Leu Gly Ser Tyr 200	Val Cys Lys Ala Asn 205
Asn 210	Gly Ile Gln Arg Phe Arg Glu Ser Thr Glu Val 215	Ile Val His Glu 220
Asn 225	Gly Pro Gly Asp Lys Thr His Thr Cys Pro 230	Pro Cys Pro Ala Pro 235 240
Glu 245	Leu Leu Gly Gly Pro Ser Val Phe Leu Phe 250	Pro Pro Lys Pro Lys 255
Asp 260	Thr Leu Met Ile Ser Arg Thr Pro Glu Val 265	Thr Cys Val Val Val 270
Asp 275	Val Ser His Glu Asp Pro Glu Val Lys Phe 280	Asn Trp Tyr Val Asp 285
Gly 290	Val Glu Val His Asn Ala Lys Thr Lys Pro 295	Arg Glu Glu Gln Tyr 300
Asn 305	Ser Thr Tyr Arg Val Val Ser Val Leu Thr 310	Val Leu His Gln Asp 315 320
Trp 325	Leu Asn Gly Lys Glu Tyr Lys Cys Lys Val 330	Ser Asn Lys Ala Leu 335
Pro 340	Ala Pro Ile Glu Lys Thr Ile Ser Lys Ala 345	Lys Gly Gln Pro Arg 350
Glu 355	Pro Gln Val Tyr Thr Leu Pro Pro Ser Arg 360	Asp Glu Leu Thr Lys 365
Asn 370	Gln Val Ser Leu Thr Cys Leu Val Lys Gly 375	Phe Tyr Pro Ser Asp 380
Ile 385	Ala Val Glu Trp Glu Ser Asn Gly Gln Pro 390	Glu Asn Asn Tyr Lys 395 400
Thr 405	Thr Pro Pro Val Leu Asp Ser Asp Gly Ser 410	Phe Phe Leu Tyr Ser 415
Lys 420	Leu Thr Val Asp Lys Ser Arg Trp Gln Gln 425	Gly Asn Val Phe Ser 430
Cys 435	Ser Val Met His Glu Ala Leu His Asn His 440	Tyr Thr Gln Lys Ser 445
Leu 450	Ser Leu Ser Pro Gly Lys 455	

<210> SEQ ID NO 15

-continued

```

<211> LENGTH: 1377
<212> TYPE: DNA
<213> ORGANISM: Homo sapiens
<220> FEATURE:
<221> NAME/KEY: CDS
<222> LOCATION: (1)...(1374)

<400> SEQUENCE: 15

atg gtc agc tac tgg gac acc ggg gtc ctg ctg tgc gcg ctg ctc agc      48
Met Val Ser Tyr Trp Asp Thr Gly Val Leu Leu Cys Ala Leu Leu Ser
  1             5             10             15

tgt ctg ctt ctc aca gga tct agt tcc gga agt gat acc ggt aga cct      96
Cys Leu Leu Leu Thr Gly Ser Ser Gly Ser Asp Thr Gly Arg Pro
             20             25             30

ttc gta gag atg tac agt gaa atc ccc gaa att ata cac atg act gaa     144
Phe Val Glu Met Tyr Ser Glu Ile Pro Glu Ile Ile His Met Thr Glu
             35             40             45

gga agg gag ctc gtc att ccc tgc cgg gtt acg tca cct aac atc act     192
Gly Arg Glu Leu Val Ile Pro Cys Arg Val Thr Ser Pro Asn Ile Thr
             50             55             60

gtt act tta aaa aag ttt cca ctt gac act ttg atc cct gat gga aaa     240
Val Thr Leu Lys Lys Phe Pro Leu Asp Thr Leu Ile Pro Asp Gly Lys
             65             70             75

cgc ata atc tgg gac agt aga aag ggc ttc atc ata tca aat gca acg     288
Arg Ile Ile Trp Asp Ser Arg Lys Gly Phe Ile Ile Ser Asn Ala Thr
             85             90             95

tac aaa gaa ata ggg ctt ctg acc tgt gaa gca aca gtc aat ggg cat     336
Tyr Lys Glu Ile Gly Leu Leu Thr Cys Glu Ala Thr Val Asn Gly His
             100            105            110

ttg tat aag aca aac tat ctc aca cat cga caa acc aat aca atc ata     384
Leu Tyr Lys Thr Asn Tyr Leu Thr His Arg Gln Thr Asn Thr Ile Ile
             115            120            125

gat gtg gtt ctg agt ccg tct cat gga att gaa cta tct gtt gga gaa     432
Asp Val Val Leu Ser Pro Ser His Gly Ile Glu Leu Ser Val Gly Glu
             130            135            140

aag ctt gtc tta aat tgt aca gca aga act gaa cta aat gtg ggg att     480
Lys Leu Val Leu Asn Cys Thr Ala Arg Thr Glu Leu Asn Val Gly Ile
             145            150            155

gac ttc aac tgg gaa tac cct tct tcg aag cat cag cat aag aaa ctt     528
Asp Phe Asn Trp Glu Tyr Pro Ser Ser Lys His Gln His Lys Lys Leu
             165            170            175

gta aac cga gac cta aaa acc cag tct ggg agt gag atg aag aaa ttt     576
Val Asn Arg Asp Leu Lys Thr Gln Ser Gly Ser Glu Met Lys Lys Phe
             180            185            190

ttg agc acc tta act ata gat ggt gta acc cgg agt gac caa gga ttg     624
Leu Ser Thr Leu Thr Ile Asp Gly Val Thr Arg Ser Asp Gln Gly Leu
             195            200            205

tac acc tgt gca gca tcc agt ggg ctg atg acc aag aag aac agc aca     672
Tyr Thr Cys Ala Ala Ser Ser Gly Leu Met Thr Lys Lys Asn Ser Thr
             210            215            220

ttt gtc agg gtc cat gaa aag gac aaa act cac aca tgc cca ccg tgc     720
Phe Val Arg Val His Glu Lys Asp Lys Thr His Thr Cys Pro Pro Cys
             225            230            235

cca gca cct gaa ctc ctg ggg gga ccg tca gtc ttc ctc ttc ccc cca     768
Pro Ala Pro Glu Leu Leu Gly Gly Pro Ser Val Phe Leu Phe Pro Pro
             245            250            255

aaa ccc aag gac acc ctc atg atc tcc cgg acc cct gag gtc aca tgc     816
Lys Pro Lys Asp Thr Leu Met Ile Ser Arg Thr Pro Glu Val Thr Cys
             260            265            270

gtg gtg gtg gac gtg agc cac gaa gac cct gag gtc aag ttc aac tgg     864
Val Val Val Asp Val Ser His Glu Asp Pro Glu Val Lys Phe Asn Trp

```

-continued

275	280	285	
tac gtg gac ggc gtg gag gtg cat aat gcc aag aca aag ccg cgg gag Tyr Val Asp Gly Val Glu Val His Asn Ala Lys Thr Lys Pro Arg Glu 290 295 300			912
gag cag tac aac agc acg tac cgt gtg gtc agc gtc ctc acc gtc ctg Glu Gln Tyr Asn Ser Thr Tyr Arg Val Val Ser Val Leu Thr Val Leu 305 310 315 320			960
cac cag gac tgg ctg aat ggc aag gag tac aag tgc aag gtc tcc aac His Gln Asp Trp Leu Asn Gly Lys Glu Tyr Lys Cys Lys Val Ser Asn 325 330 335			1008
aaa gcc ctc cca gcc ccc atc gag aaa acc atc tcc aaa gcc aaa ggg Lys Ala Leu Pro Ala Pro Ile Glu Lys Thr Ile Ser Lys Ala Lys Gly 340 345 350			1056
cag ccc cga gaa cca cag gtg tac acc ctg ccc cca tcc cgg gat gag Gln Pro Arg Glu Pro Gln Val Tyr Thr Leu Pro Pro Ser Arg Asp Glu 355 360 365			1104
ctg acc aag aac cag gtc agc ctg acc tgc ctg gtc aaa ggc ttc tat Leu Thr Lys Asn Gln Val Ser Leu Thr Cys Leu Val Lys Gly Phe Tyr 370 375 380			1152
ccc agc gac atc gcc gtg gag tgg gag agc aat ggg cag ccg gag aac Pro Ser Asp Ile Ala Val Glu Trp Glu Ser Asn Gly Gln Pro Glu Asn 385 390 395 400			1200
aac tac aag acc acg cct ccc gtg ctg gac tcc gac ggc tcc ttc ttc Asn Tyr Lys Thr Thr Pro Pro Val Leu Asp Ser Asp Gly Ser Phe Phe 405 410 415			1248
ctc tac agc aag ctc acc gtg gac aag agc agg tgg cag cag ggg aac Leu Tyr Ser Lys Leu Thr Val Asp Lys Ser Arg Trp Gln Gln Gly Asn 420 425 430			1296
gtc ttc tca tgc tcc gtg atg cat gag gct ctg cac aac cac tac acg Val Phe Ser Cys Ser Val Met His Glu Ala Leu His Asn His Tyr Thr 435 440 445			1344
cag aag agc ctc tcc ctg tct ccg ggt aaa tga Gln Lys Ser Leu Ser Leu Ser Pro Gly Lys 450 455			1377
<210> SEQ ID NO 16			
<211> LENGTH: 458			
<212> TYPE: PRT			
<213> ORGANISM: Homo sapiens			
<400> SEQUENCE: 16			
Met Val Ser Tyr Trp Asp Thr Gly Val Leu Leu Cys Ala Leu Leu Ser 1 5 10 15			
Cys Leu Leu Leu Thr Gly Ser Ser Ser Gly Ser Asp Thr Gly Arg Pro 20 25 30			
Phe Val Glu Met Tyr Ser Glu Ile Pro Glu Ile Ile His Met Thr Glu 35 40 45			
Gly Arg Glu Leu Val Ile Pro Cys Arg Val Thr Ser Pro Asn Ile Thr 50 55 60			
Val Thr Leu Lys Lys Phe Pro Leu Asp Thr Leu Ile Pro Asp Gly Lys 65 70 75 80			
Arg Ile Ile Trp Asp Ser Arg Lys Gly Phe Ile Ile Ser Asn Ala Thr 85 90 95			
Tyr Lys Glu Ile Gly Leu Leu Thr Cys Glu Ala Thr Val Asn Gly His 100 105 110			
Leu Tyr Lys Thr Asn Tyr Leu Thr His Arg Gln Thr Asn Thr Ile Ile 115 120 125			
Asp Val Val Leu Ser Pro Ser His Gly Ile Glu Leu Ser Val Gly Glu			

-continued

Asp Gly Lys Arg Ile Ile Trp Asp Ser Arg Lys Gly Phe Ile Ile Ser
 50 55 60
 Asn Ala Thr Tyr Lys Glu Ile Gly Leu Leu Thr Cys Glu Ala Thr Val
 65 70 75 80
 Asn Gly His Leu Tyr Lys Thr Asn Tyr Leu Thr His Arg Gln Thr Asn
 85 90 95
 Thr Ile Ile Asp Val Val Leu Ser Pro Ser His Gly Ile Glu Leu Ser
 100 105 110
 Val Gly Glu Lys Leu Val Leu Asn Cys Thr Ala Arg Thr Glu Leu Asn
 115 120 125
 Val Gly Ile Asp Phe Asn Trp Glu Tyr Pro Ser Ser Lys His Gln His
 130 135 140
 Lys Lys Leu Val Asn Arg Asp Leu Lys Thr Gln Ser Gly Ser Glu Met
 145 150 155 160
 Lys Lys Phe Leu Ser Thr Leu Thr Ile Asp Gly Val Thr Arg Ser Asp
 165 170 175
 Gln Gly Leu Tyr Thr Cys Ala Ala Ser Ser Gly Leu Met Thr Lys Lys
 180 185 190
 Asn Ser Thr Phe Val Arg Val His Glu Lys Gly Pro Gly Asp Lys Thr
 195 200 205
 His Thr Cys Pro Pro Cys Pro Ala Pro Glu Leu Leu Gly Gly Pro Ser
 210 215 220
 Val Phe Leu Phe Pro Pro Lys Pro Lys Asp Thr Leu Met Ile Ser Arg
 225 230 235 240
 Thr Pro Glu Val Thr Cys Val Val Val Asp Val Ser His Glu Asp Pro
 245 250 255
 Glu Val Lys Phe Asn Trp Tyr Val Asp Gly Val Glu Val His Asn Ala
 260 265 270
 Lys Thr Lys Pro Arg Glu Glu Gln Tyr Asn Ser Thr Tyr Arg Val Val
 275 280 285
 Ser Val Leu Thr Val Leu His Gln Asp Trp Leu Asn Gly Lys Glu Tyr
 290 295 300
 Lys Cys Lys Val Ser Asn Lys Ala Leu Pro Ala Pro Ile Glu Lys Thr
 305 310 315 320
 Ile Ser Lys Ala Lys Gly Gln Pro Arg Glu Pro Gln Val Tyr Thr Leu
 325 330 335
 Pro Pro Ser Arg Asp Glu Leu Thr Lys Asn Gln Val Ser Leu Thr Cys
 340 345 350
 Leu Val Lys Gly Phe Tyr Pro Ser Asp Ile Ala Val Glu Trp Glu Ser
 355 360 365
 Asn Gly Gln Pro Glu Asn Asn Tyr Lys Thr Thr Pro Pro Val Leu Asp
 370 375 380
 Ser Asp Gly Ser Phe Phe Leu Tyr Ser Lys Leu Thr Val Asp Lys Ser
 385 390 395 400
 Arg Trp Gln Gln Gly Asn Val Phe Ser Cys Ser Val Met His Glu Ala
 405 410 415
 Leu His Asn His Tyr Thr Gln Lys Ser Leu Ser Pro Gly Lys
 420 425 430

<210> SEQ ID NO 18

<211> LENGTH: 36

<212> TYPE: DNA

<213> ORGANISM: Artificial Sequence

<220> FEATURE:

<223> OTHER INFORMATION: primer

-continued

<400> SEQUENCE: 18
gactagcagt ccggaggtag accttcgta gagatg 36

<210> SEQ ID NO 19
<211> LENGTH: 33
<212> TYPE: DNA
<213> ORGANISM: Artificial Sequence
<220> FEATURE:
<223> OTHER INFORMATION: primer

<400> SEQUENCE: 19
cggactcaga accacatcta tgattgtatt ggt 33

<210> SEQ ID NO 20
<211> LENGTH: 7
<212> TYPE: PRT
<213> ORGANISM: Homo sapiens

<400> SEQUENCE: 20
Gly Arg Pro Phe Val Glu Met
1 5

<210> SEQ ID NO 21
<211> LENGTH: 35
<212> TYPE: DNA
<213> ORGANISM: Artificial Sequence
<220> FEATURE:
<223> OTHER INFORMATION: primer

<400> SEQUENCE: 21
acaatcatag atgtggttct gagtccgtct catgg 35

<210> SEQ ID NO 22
<211> LENGTH: 38
<212> TYPE: DNA
<213> ORGANISM: Artificial Sequence
<220> FEATURE:
<223> OTHER INFORMATION: primer

<400> SEQUENCE: 22
gataatgccccc gggccctttt catggaccct gacaaaatg 38

<210> SEQ ID NO 23
<211> LENGTH: 6
<212> TYPE: PRT
<213> ORGANISM: Homo sapiens

<400> SEQUENCE: 23
Val Arg Val His Glu Lys
1 5

<210> SEQ ID NO 24
<211> LENGTH: 36
<212> TYPE: DNA
<213> ORGANISM: Artificial Sequence
<220> FEATURE:
<223> OTHER INFORMATION: primer

<400> SEQUENCE: 24
gactagcagt ccggaggtag accttcgta gagatg 36

<210> SEQ ID NO 25
<211> LENGTH: 38
<212> TYPE: DNA

-continued

```

<213> ORGANISM: Artificial Sequence
<220> FEATURE:
<223> OTHER INFORMATION: primer

<400> SEQUENCE: 25
ttcctgggca acagctggat atctatgatt gtattggt          38

<210> SEQ ID NO 26
<211> LENGTH: 4
<212> TYPE: PRT
<213> ORGANISM: Homo sapiens

<400> SEQUENCE: 26
Ile Gln Leu Leu
1

<210> SEQ ID NO 27
<211> LENGTH: 39
<212> TYPE: DNA
<213> ORGANISM: Artificial Sequence
<220> FEATURE:
<223> OTHER INFORMATION: primer

<400> SEQUENCE: 27
atccagctgt tgcccaggaa gtcgctggag ctgctggta        39

<210> SEQ ID NO 28
<211> LENGTH: 39
<212> TYPE: DNA
<213> ORGANISM: Artificial Sequence
<220> FEATURE:
<223> OTHER INFORMATION: primer

<400> SEQUENCE: 28
attttcatgc acaatgacct cggtgctctc ccgaaatcg        39

<210> SEQ ID NO 29
<211> LENGTH: 38
<212> TYPE: DNA
<213> ORGANISM: Artificial Sequence
<220> FEATURE:
<223> OTHER INFORMATION: primer

<400> SEQUENCE: 29
tcatagatat ccagctgttg cccaggaagt cgctggag          38

<210> SEQ ID NO 30
<211> LENGTH: 39
<212> TYPE: DNA
<213> ORGANISM: Artificial Sequence
<220> FEATURE:
<223> OTHER INFORMATION: primer

<400> SEQUENCE: 30
gataatgccc gggccatttt catgcacaat gacctcgg          39

<210> SEQ ID NO 31
<211> LENGTH: 6
<212> TYPE: PRT
<213> ORGANISM: Homo sapiens

<400> SEQUENCE: 31
Val Ile Val His Glu Asn
1           5

```

-continued

```

<210> SEQ ID NO 32
<211> LENGTH: 10
<212> TYPE: PRT
<213> ORGANISM: Artificial Sequence
<220> FEATURE:
<223> OTHER INFORMATION: modified Flt1 receptor

```

```

<400> SEQUENCE: 32

```

```

Lys Asn Lys Arg Ala Ser Val Arg Arg Arg
1           5           10

```

```

<210> SEQ ID NO 33
<211> LENGTH: 8
<212> TYPE: PRT
<213> ORGANISM: Artificial Sequence
<220> FEATURE:
<223> OTHER INFORMATION: modified Flt1 receptor

```

```

<400> SEQUENCE: 33

```

```

Asn Ala Ser Val Asn Gly Ser Arg
1           5

```

```

<210> SEQ ID NO 34
<211> LENGTH: 10
<212> TYPE: PRT
<213> ORGANISM: Artificial Sequence
<220> FEATURE:
<223> OTHER INFORMATION: modified Flt1 receptor

```

```

<400> SEQUENCE: 34

```

```

Lys Asn Lys Cys Ala Ser Val Arg Arg Arg
1           5           10

```

```

<210> SEQ ID NO 35
<211> LENGTH: 4
<212> TYPE: PRT
<213> ORGANISM: Homo sapiens

```

```

<400> SEQUENCE: 35

```

```

Ser Lys Leu Lys
1

```

```

<210> SEQ ID NO 36
<211> LENGTH: 9
<212> TYPE: PRT
<213> ORGANISM: Homo sapiens

```

```

<400> SEQUENCE: 36

```

```

Lys Asn Lys Arg Ala Ser Val Arg Arg
1           5

```

```

<210> SEQ ID NO 37
<211> LENGTH: 4
<212> TYPE: PRT
<213> ORGANISM: Homo sapiens

```

```

<400> SEQUENCE: 37

```

```

Thr Ile Ile Asp
1

```

```

<210> SEQ ID NO 38
<211> LENGTH: 4
<212> TYPE: PRT
<213> ORGANISM: Homo sapiens

```

-continued

<400> SEQUENCE: 38

Val Val Leu Ser

1

We claim:

1. A method of inhibiting vascular endothelial growth factor (VEGF) activity in a mammal, comprising:
 administering a pharmaceutical composition to the mammal, wherein the pharmaceutical composition comprises
 (a) a VEGF antagonist, and
 (b) a pharmaceutically acceptable carrier
 wherein the VEGF antagonist comprises a dimeric fusion polypeptide comprising two fusion polypeptides, each fusion polypeptide comprising:
 (i) a VEGF receptor component consisting of an immunoglobulin-like (Ig) domain 2 of a first VEGF receptor human Flt1 and Ig domain 3 of a second VEGF receptor human Flk1 or human Flt4; and
 (ii) a multimerizing component,
 wherein VEGF activity is inhibited.
2. The method of claim 1, wherein the mammal is a human.

- 10 3. A method of inhibiting tumor growth in a mammal, comprising:
 administering a pharmaceutical composition to the mammal, wherein the pharmaceutical composition comprises
 15 (a) a VEGF antagonist, and
 (b) a pharmaceutically acceptable carrier
 wherein the VEGF antagonist comprises a dimeric fusion polypeptide comprising two fusion polypeptides, each fusion polypeptide comprising:
 20 (i) a VEGF receptor component consisting of an immunoglobulin-like (Ig) domain 2 of a first VEGF receptor human Flt1 and Ig domain 3 of a second VEGF receptor human Flk1 or human Flt4; and
 25 (ii) a multimerizing component,
 wherein tumor growth is inhibited.

* * * * *

ATTACHMENT E

**Copy of Terminal Disclaimer for
U.S. Patent 7,374,758**

Application Number 	Application/Control No. 11/016,503	Applicant(s)/Patent under Reexamination PAPADOPOULOS ET AL.

Document Code - DISQ	Internal Document – DO NOT MAIL
-----------------------------	--

TERMINAL DISCLAIMER	<input checked="" type="checkbox"/> APPROVED	<input type="checkbox"/> DISAPPROVED
Date Filed : 01/04/08	This patent is subject to a Terminal Disclaimer	

Approved/Disapproved by: Felicia D. Roberts 11/155,269 11/502,736 11/373,358 11/089,803 10/988,243 10/860,958

U.S. Patent and Trademark Office

ATTACHMENT F

**Copy of Maintenance Fee Statement
for
U.S. Patent 7,374,758**



Customer No 000000000

ISTMT

DATE PRINTED
12/20/2011

REGENERON PHARMACEUTICALS, INC
777 OLD SAW MILL RIVER ROAD
TARRYTOWN NY 10591

MAINTENANCE FEE STATEMENT

According to the records of the U.S. Patent and Trademark Office (USPTO), the maintenance fee and any necessary surcharge have been timely paid for the patent listed below. The "PYMT DATE" column indicates the payment date (i.e., the date the payment was filed).

The payment shown below is subject to actual collection. If the payment is refused or charged back by a financial institution, the payment will be void and the maintenance fee and any necessary surcharge unpaid.

Direct any questions about this statement to: Mail Stop M Correspondence, Director of the USPTO, P.O.Box 1450, Alexandria, VA 22313-1450.

PATENT NUMBER	FEE AMT	SUR CHARGE	PYMT DATE	U.S. APPLICATION NUMBER	PATENT ISSUE DATE	APPL. FILING DATE	PAYMENT YEAR	SMALL ENTITY?	ATTY DKT NUMBER
7,374,758	\$1,130.00	\$0.00	11/14/11	11/016,503	05/20/08	12/17/04	04	NO	QR 0710 (A2)

ATTACHMENT G

**Copy of Holash *et al.* PNAS 99(17):11393-
11398 (2002)**

VEGF-Trap: A VEGF blocker with potent antitumor effects

Jocelyn Holash*, Sam Davis, Nick Papadopoulos, Susan D. Croll, Lillian Ho, Michelle Russell, Patricia Boland, Ray Leidich, Donna Hylton, Elena Burova, Ella Ioffe, Tammy Huang, Czeslaw Radziejewski, Kevin Bailey, James P. Fandl, Tom Daly, Stanley J. Wiegand, George D. Yancopoulos, and John S. Rudge

Regeneron Pharmaceuticals, Incorporated, 777 Old Saw Mill River Road, Tarrytown, NY 10591

Communicated by P. Roy Vagelos, Merck & Co., Inc., Bedminster, NJ, July 2, 2002 (received for review April 19, 2002)

Vascular endothelial growth factor (VEGF) plays a critical role during normal embryonic angiogenesis and also in the pathological angiogenesis that occurs in a number of diseases, including cancer. Initial attempts to block VEGF by using a humanized monoclonal antibody are beginning to show promise in human cancer patients, underscoring the importance of optimizing VEGF blockade. Previous studies have found that one of the most effective ways to block the VEGF-signaling pathway is to prevent VEGF from binding to its normal receptors by administering decoy-soluble receptors. The highest-affinity VEGF blocker described to date is a soluble decoy receptor created by fusing the first three Ig domains of VEGF receptor 1 to an Ig constant region; however, this fusion protein has very poor *in vivo* pharmacokinetic properties. By determining the requirements to maintain high affinity while extending *in vivo* half life, we were able to engineer a very potent high-affinity VEGF blocker that has markedly enhanced pharmacokinetic properties. This VEGF-Trap effectively suppresses tumor growth and vascularization *in vivo*, resulting in stunted and almost completely avascular tumors. VEGF-Trap-mediated blockade may be superior to that achieved by other agents, such as monoclonal antibodies targeted against the VEGF receptor.

The sprouting of new blood vessels, termed angiogenesis, is required to support growth in the embryo and young animal, as well as to allow for repair and remodeling processes in the adult. However, aberrant angiogenesis is also associated with a number of pathological conditions and diseases, including cancer (1, 2). Tumors, like many normal tissues, use the vasculature as a means to obtain oxygen and nutrients and to remove waste products. Although tumors can in part grow by coopting existing host vessels (3–6), most tumors also induce new vessel formation, suggesting that this neovascularization is required for their growth (1, 2, 7). Consequently, much effort has been directed toward discovering antiangiogenic agents and evaluating them as cancer therapeutics. Perhaps the best characterized and most highly validated antiangiogenic approach involves targeting the vascular endothelial growth factor (VEGF) pathway (1, 8–11). Based on numerous animal studies, the VEGF pathway is the only well-defined signaling pathway known to be required for normal development of the vasculature as well as for the pathologic angiogenesis that accompanies cancer and other disease states (8–10).

The VEGF pathway is initiated when VEGF binds to its receptors on endothelial cells. The two best characterized VEGF receptors are termed VEGF receptor 1 (VEGFR1) and VEGF receptor 2 (VEGFR2). VEGFR1 and VEGFR2 are highly related transmembrane tyrosine kinases that use their ectodomains to bind VEGF; this binding in turn activates the intrinsic tyrosine kinase activity of their cytodomains, initiating intracellular signaling. Interestingly, although VEGFR1 binds to VEGF with substantially higher affinity, most of the biologic effects of VEGF seem to be mediated via VEGFR2. In animals, blockade of the VEGF pathway has been achieved by many different means, including blocking antibodies targeted against VEGF (12–14) or its receptors (15), soluble decoy receptors that

prevent VEGF from binding to its normal receptors (16–20), as well as small molecule inhibitors of the tyrosine kinase activity of the VEGFRs (21–23). Recently, a study that compared the efficacy of VEGF blockade to other “antiangiogenic” strategies established that this approach is superior to many others (ref. 11). Consistent with predictions from animal studies, blockade of VEGF using a humanized monoclonal antibody has emerged as the first and thus far only antiangiogenesis approach reporting promising results in human cancer patients, based on preliminary reports from early clinical trials.[†] The hope is that anti-VEGF approaches can be generalized to many different types of cancer, as well as to other diseases in which pathologic angiogenesis contributes, such as diabetic retinopathy and psoriasis.

The clinical promise of initial anti-VEGF approaches highlights the need to optimize blockade of this pathway. Previous studies have found that one of the most effective ways to block the VEGF signaling pathway is to prevent VEGF from binding to its normal receptors by administering decoy VEGF receptors (11, 16, 17, 24). The highest-affinity VEGF blocker described to date is a soluble decoy receptor created by fusing the first three Ig domains of VEGFR1 to the constant region (Fc portion) of human IgG1, resulting in a forced homodimer that has picomolar binding affinity (16, 17). In tumor experiments, this VEGFR1-Fc reagent is efficacious at approximately 500-fold lower concentration than a similar VEGFR-2 construct (11). Despite its high affinity, the VEGFR1-Fc is not a feasible clinical candidate because of its poor pharmacokinetic profile; in rodent studies, this protein has to be administered frequently and at very high levels to achieve efficacious levels (16, 17, 24). In addition, the VEGFR1-Fc exhibits certain toxicological side effects that are not seen with the VEGFR2-Fc (11). These effects appear to be due to nonmechanism-based and nonspecific properties of this agent (see *Discussion*). By determining the requirements to maintain high affinity while extending *in vivo* half life, we were able to engineer a very potent high-affinity VEGF blocker that has prolonged *in vivo* pharmacokinetics and pharmacodynamics, lacks nonspecific toxicities, and can effectively suppress the growth and vascularization of a number of different types of tumors *in vivo*.

Materials and Methods

Engineering VEGF-Traps. The parental VEGF-Trap was created by fusing the first three Ig domains of VEGFR1 to the constant region (Fc) of human IgG1. VEGF-Trap_{ΔB1} was created by removing a highly basic 10-aa stretch from the third Ig domain of the parental VEGF-Trap. VEGF-Trap_{ΔB2} was created by removing the entire first Ig domain from VEGF-Trap_{ΔB1}. VEGF-Trap_{R1R2} was created by fusing the second Ig domain

Abbreviations: VEGF, vascular endothelial growth factor; VEGFR1, VEGF receptor 1; VEGFR2, VEGF receptor 2; AUC, area under the curve.

*To whom reprint requests should be addressed. E-mail: jocelyn.holash@regeneron.com.

[†]Yang, J., Haworth, L., Steinberg, S., Rosenberg, S., & Novotny, W. (2002) *Am. Soc. Clin. Oncol.* (abstr. 15).

of VEGFR1 with the third Ig domain of VEGFR2. All of the VEGF-Trap variants were produced and purified from Chinese hamster ovary cells.

Pharmacokinetic Analysis of VEGF-Traps. BALB/c mice (25–30 g) were injected s.c. with 4 mg/kg of the various Traps and bled at 1, 2, 4, 6, 24, 48, 72, and 144 hr after injection. Levels of all VEGF-Traps were measured by an ELISA by using human VEGF₁₆₅ to capture and an antibody to the human Fc region as the reporter.

Extracellular Matrix (ECM)-Binding Assay. ECM-coated plates (Becton Dickinson no. 35–4607) were incubated with varying concentrations of VEGF-Traps for 1 hr at room temperature. They were washed and incubated with alkaline phosphatase-conjugated anti-human Fc antibody (Promega, 1:4,000 in PBS + 10% BCS) for 1 hr at room temperature. Plates were washed four times with PBS + 0.1% Triton-X 100 and reagent buffer added for color development. Plates were read at 405–570 nm.

VEGF-Trap-Binding Assay. Binding affinities of VEGF-Traps were measured by using a specific and sensitive ELISA (R&D Systems kit no. DVE00) for detecting free (unbound) human VEGF in mixtures of the VEGF-Traps (ranging in concentration from 0.1 to 160 pM) with human VEGF₁₆₅ (at 10 pM), incubated overnight at room temperature.

Human Umbilical Vein Endothelial Cell Phosphorylation Assay. Confluent monolayers of human umbilical vein endothelial cells [Vec Technologies (Rensselaer, NY) passage no. 5] were serum-starved for 2 hr and then challenged for 5 min with vehicle or 40 ng/ml of human VEGF₁₆₅, alone or preincubated with VEGF-Traps at 1.5-fold molar excess. Cells were then lysed, immunoprecipitated by using a VEGFR2-specific antibody, and immunoblotted with a phosphotyrosine-specific antibody (Upstate Biotechnology, 4G10 mAb).

VEGF-Induced Proliferation Assay. Cells that proliferate in response to VEGF were generated by stably transfecting NIH 3T3 cells with a VEGFR2/TrkB chimeric receptor (in which the cytodomain of VEGFR2 was replaced with that of TrkB, a receptor for brain-derived neurotrophic factor that effectively drives proliferation in these cells). Five thousand cells were plated per well of a 96-well plate, allowed to settle for 2 hr, incubated for 1 hr with VEGF-Trap variants (titrated from 40 nM to 20 pM), then challenged for 72 hr with human VEGF₁₆₅ at a concentration of 1.56 nM, followed by addition of [3-(4,5 dimethylthiazol-2-yl)-5-(3-carboxymethoxyphenyl)-2-(4-sulfophenyl)-2H-tetrazolium, innersai and spectrophotometric analysis at 450/570 nm.

Acute Hypotension. Male Wistar-Kyoto rats (180–240 g) from Taconic Laboratories were maintained on a 12:12 light/dark cycle (lights on 0600) with food and water available *ad libitum*. Before challenge with VEGF, animals were pretreated with VEGF-Traps or PBS as indicated, anesthetized with 1.5–2% isoflurane in oxygen, and the left femoral artery catheterized for direct measurement of systolic blood pressure through a blood pressure transducer (IITC, Woodland Hills, CA) into a chart recorder (Linseis, Princeton Junction, NJ). Animals were then injected in the right jugular vein with a 200- μ l bolus containing 10 μ g of recombinant human VEGF₁₆₅. Systolic blood pressure was measured before VEGF injection and every minute thereafter for 20 min. Blood pressures were normalized to baseline preinjection and analyzed by using mixed factorial ANOVAs (see supporting information on the PNAS web site, www.pnas.org).

Tumor Growth Experiments. C6 glioma cells (1.0×10^6 cells/mouse) and A673 rhabdomyosarcoma cells (2.0×10^6 cells/mouse) were

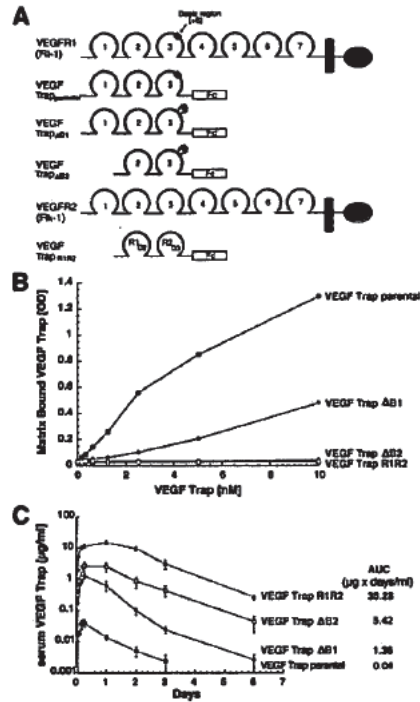

Fig. 1. Engineering of VEGF-Traps with improved pharmacokinetics. (A) Schematics of full-length VEGFR1 (red) and VEGFR2 (blue) are provided, indicating their seven Ig domains, transmembrane regions (black bars), and kinase domains (ovals). The parental VEGF-Trap contains the first three Ig domains of VEGFR1 (including the highly basic 10-aa stretch in Ig3, blue box) fused to the Fc portion of human IgG1. VEGF-Trap Δ B1 is identical to the parental VEGF-Trap, except that the basic stretch in Ig3 has been removed. VEGF-Trap Δ B2 is the same construct as Δ B1, except that the first Ig domain has been removed. VEGF-Trap Δ R1R2 possesses the second Ig domain of VEGFR1 and the third Ig domain of VEGFR2 fused to the Fc portion of human IgG1. (B) The four indicated VEGF-Traps were assayed *in vitro* for their capacity to bind to extracellular matrix, with only the parental VEGF-Trap and VEGF-Trap Δ B1 demonstrating binding. (C) Pharmacokinetic analysis of the VEGF-Traps reveals that the parental VEGF-Trap has the poorest profile, whereas VEGF-Trap Δ R1R2 showed the best profile.

obtained from American Type Culture Collection, and B16F10.9 melanoma cells (5.0×10^5 cells/mouse) were a generous gift from Charles Lin (Duke University, Durham, NC). Cells were suspended in serum-free medium and implanted s.c. on the shaved right flank of male C.B-17 SCID mice at the indicated concentrations. After tumor cell implantation and twice weekly thereafter for the duration of the experiment, mice received a s.c. injection (at the nape of the neck) of vehicle (PBS + 0.5% glycerol), VEGF-Trap, or DC101 (from American Type Culture Collection). After 2–3.0 weeks, animals were killed and tumors were measured *ex vivo* with calipers (tumor volume = length \times width \times height). For immunohistochemistry studies, mice were perfused with 4% paraformaldehyde, and tissue was processed as previously described (25).

Results

Reengineering Parental VEGF-Trap to Improve Its Pharmacokinetic Profile. On the basis of the previously reported high affinity of a soluble decoy receptor in which VEGFR1 is fused to the Fc portion of human IgG1 (16, 17), we produced this fusion protein to study its properties (see parental VEGF-Trap, Fig. 1A). Single s.c. injections of parental VEGF-Trap (4 mg/kg) into mice were

performed to confirm that it indeed displayed poor pharmacokinetic properties, with a maximal concentration (C_{max}) of only 0.05 $\mu\text{g}/\text{ml}$ and total "area under the curve concentration" (AUC) of 0.04 $\mu\text{g} \times \text{days}/\text{ml}$ (Fig. 1C). We postulated that these poor pharmacokinetic properties might be due to the high positive charge of this protein (pI 9.4), which in turn may result in its deposition at the site of s.c. injection because of nonspecific adhesion to highly negatively charged proteoglycans that comprise the extracellular matrix. To test this hypothesis, we next engineered several variants of the parental VEGF-Trap with reduced positive charges. On review of the charge density in the parental molecule, we noted a highly basic stretch of 10 amino acids in the third Ig domain of VEGFR1 (see blue box in Fig. 1A). To reduce the charge, this region was excised, resulting in a decrease in the pI of this VEGF-Trap (termed VEGF-Trap ΔB1 ; see Fig. 1A) from 9.4 to 9.1. It was also noted that the first Ig domain of VEGFR1 had a basic pI, and we thus decided to test removal of this domain as well as the above-noted basic region, resulting in a protein termed VEGF-Trap ΔB2 (Fig. 1A), with a further reduced pI of 8.9. Finally, because the third Ig domain of VEGFR2 has a lower pI than the corresponding domain of VEGFR1, we simply switched these domains to make a Trap in which the second Ig domain of VEGFR1 is directly fused to the third Ig domain of VEGFR2; this trap was termed VEGF-Trap R1R2 (Fig. 1A) and had a pI of 8.82. Previous structural analyses indicated that VEGFR1 might make greater use of its second Ig domain in contacting VEGF, whereas VEGFR2 instead makes greater use of its third Ig domain (26), raising the interesting and useful possibility that VEGF-Trap R1R2 might actually bind more tightly to VEGF than the parental versions. Combining the distinct binding regions of two different receptors to create a higher-affinity interactor has previously been used in the creation of a series of interleukin and cytokine blockers also termed Traps (A. Economides, L. Rocco Carpenter, J.S.R., V. Wong, E. Koehler-Stec, C. Hartnett, E. Pyles, T.D., M. Young, J.P.F., Frank Lee, Scott Carver, Jennifer McNay, K.B., S. Ramakanth, R. Hatabarat, C.R., T.H., G.D.Y., and N. Stahl, unpublished results). Using a simple extracellular matrix-binding assay, we then confirmed the hypothesis that decreasing the positive charge of the VEGF-Traps would result in decreased adhesion to extracellular matrix (Fig. 1B). Binding to extracellular matrix in this assay was directly related to the pI of the Traps, with both VEGF-Trap R1R2 and VEGF-Trap ΔB2 displaying negligible binding in this assay.

On the basis of the above results, we next tested these various VEGF-Traps *in vivo* for their pharmacokinetic behavior. Their *in vivo* behavior followed the theoretical charge predictions as well as the *in vitro* adhesion properties. Every reduction in pI was accompanied by a corresponding improvement in C_{max} and AUC: VEGF-Trap ΔB1 had a C_{max} of 1.3 $\mu\text{g}/\text{ml}$ and an AUC of 1.36 $\mu\text{g} \times \text{days}/\text{ml}$; VEGF-Trap ΔB2 had a C_{max} of 2.65 $\mu\text{g}/\text{ml}$ and an AUC of 5.42 $\mu\text{g} \times \text{days}/\text{ml}$; whereas VEGF-Trap R1R2 revealed the best profile with a C_{max} of 16 $\mu\text{g}/\text{ml}$ and an AUC of 36.28 $\mu\text{g} \times \text{days}/\text{ml}$ (Fig. 1C). Thus, VEGF-Trap R1R2 had an AUC that was almost 1,000-fold higher than that of the parental VEGF-Trap, raising the possibility that it might be a far superior pharmacologic agent, assuming it retained its ability to bind and block VEGF.

Comparison of Parental VEGF-Trap with VEGF-Trap R1R2 in Binding, Phosphorylation, and Cell Proliferation Assays *in Vitro*. Because of the superior pharmacokinetic properties of VEGF-Trap R1R2 , we next compared this Trap to its parent for its ability to bind and block VEGF *in vitro*. To determine binding affinity of the Traps for VEGF, equilibrium binding assays were performed in which different concentrations of the Traps were incubated with VEGF $_{165}$, and the amount of unbound VEGF $_{165}$ was measured, revealing that parental VEGF-Trap displays a K_D of ≈ 5 pM, whereas VEGF-Trap R1R2 has a binding affinity of about 1 pM (Fig. 2A). Preliminary

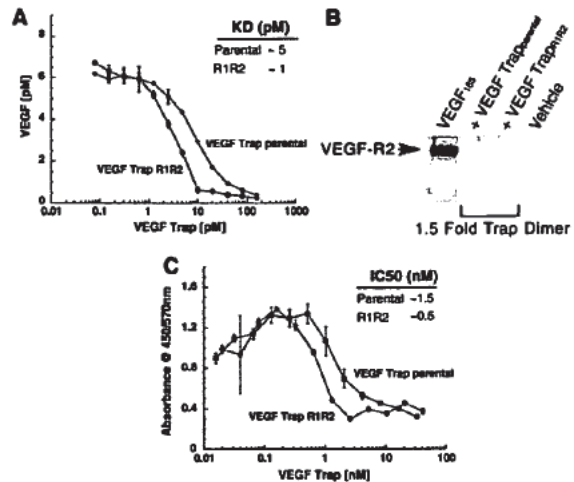

Fig. 2. Binding affinity and inhibitory properties of VEGF-Traps. (A) Affinities of indicated VEGF-Traps for VEGF, as determined by using a binding assay that measures unbound VEGF (ordinate) after incubation of 10 pM of human VEGF $_{165}$ with varying concentrations of VEGF-Traps (abscissa). (B) Inhibition of VEGF-induced phosphorylation of VEGFR2 in human umbilical vein endothelial cell phosphorylations using indicated VEGF-Traps at 1.5-fold molar excess, as revealed by immunoblotting assay. (C) Inhibition of VEGF-induced proliferation of fibroblasts containing a chimeric VEGFR2/TrkB receptor, using varying concentrations of VEGF-Traps in the presence of 1.56 nM of VEGF.

analyses show that VEGF-Trap R1R2 has a K_D of ≈ 1 –10 pM for VEGF $_{121}$ and approximately 45 pM for placental growth factor 2 (not shown); other VEGF isoforms and relatives have not been analyzed.

To determine whether Trap binding of VEGF could potentially and effectively block the ability of VEGF to activate its receptor, VEGF and Traps were added to cultured endothelial cells, and the effects on VEGFR2 phosphorylation were examined, revealing that both parental VEGF-Trap as well as VEGF-Trap R1R2 can completely block VEGF-induced VEGFR2 phosphorylation when added at a 1.5-fold molar excess compared with the added VEGF, consistent with very high-affinity binding to VEGF (Fig. 2B). Finally, to assess whether these Traps would also be effective in cell-based proliferation assays, we engineered a cell line containing a chimeric VEGFR2 receptor that mediates a very strong proliferative response to VEGF and found that both parental VEGF-Trap and VEGF-Trap R1R2 potentially blocked VEGF-induced proliferation in 3-day growth assays in these cells, with an IC_{50} at approximately an equimolar concentration of Trap with the added VEGF, once again consistent with very high-affinity binding of the Traps for VEGF (Fig. 2C).

VEGF-Trap R1R2 Provides Long-Term Blockade of Exogenously Administered VEGF-Induced Acute Hypotension. The above studies indicated that VEGF-Trap R1R2 was at least as impressive a blocker of VEGF as the parental version, but that it had far superior pharmacokinetic properties. To initially explore whether these attributes translated into superior pharmacodynamic performance, we compared these reagents by using an acute readout of VEGF responsiveness *in vivo*. Administration of a single bolus dose (10 μg) of recombinant VEGF $_{165}$ to rats results in acute hypotension, with a drop of about 40% from baseline systolic blood pressure; this drop is maximal at 5 min and slowly rectifies to normal by about 30 min (Fig. 3A). To compare the pharmacodynamic efficacy of the VEGF-Traps in blocking this acute response, we preadministered the parental VEGF-Trap or

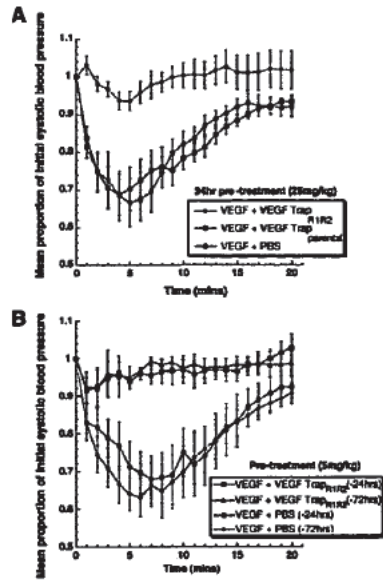

Fig. 3. Using blockade of VEGF-induced acute hypotension to pharmacodynamically compare VEGF-Traps. (A) When rats were treated with VEGF-Traps at 25 mg/kg at 1 day before VEGF challenge, VEGF-Trap_{R1R2} ($n = 8$) completely blocked VEGF-induced hypotension, whereas PBS ($n = 6$) and parental VEGF-Trap ($n = 6$) were ineffective. ANOVA shows treatment effect, $P < 0.007$. (B) At a 5-fold lower dose (5 mg/kg), VEGF-Trap_{R1R2} was still effective at 1 day ($n = 4$) or 3 days ($n = 3$) before the VEGF challenge. ANOVA shows treatment effect, $P < 0.03$.

VEGF-Trap_{R1R2} at 25 mg/kg, 24 hr before VEGF administration (Fig. 3A). Consistent with what would be expected from the above pharmacokinetic studies, this dose of VEGF-Trap_{R1R2} completely blocked VEGF-induced hypotension, whereas the parental VEGF-Trap had no discernable effect. Thus, although the parental VEGF-Trap and its VEGF-Trap_{R1R2} derivative are quite comparable *in vitro* (see above), the VEGF-Trap_{R1R2} performs much better *in vivo*, presumably because of its dramatically enhanced pharmacokinetic profile.

To further characterize the length of time in which VEGF-Trap_{R1R2} remained efficacious, we waited 1, 3, and 7 days after injection of the Trap at 5 mg/kg before inducing hypotension. At this dose, VEGF-Trap_{R1R2} was completely effective in blocking VEGF-induced acute hypotension at 1 and 3 days after a single bolus (Fig. 3B) but was not significantly different from controls at 7 days (data not shown).

VEGF-Trap_{R1R2} Dramatically Blocks Tumor Growth *in Vivo*. Altogether, the above pharmacokinetic and pharmacodynamic studies indicated that VEGF-Trap_{R1R2} has the potential to be a long-term and potent pharmacologic blocker of VEGF-mediated activities *in vivo*, far superior to that of parental VEGF-Trap. To begin to explore the value of VEGF-Trap_{R1R2} as an anticancer therapeutic and to compare it to other effective agents targeting the VEGF pathway, we evaluated its ability to block the growth of a variety of tumor cell lines in s.c. tumor models in mice. Tumor cells were derived from diverse tissue origins and different species (mouse B16F10.9 melanoma, human A673 rhabdomyosarcoma, and rat C6 glioma). After implantation of tumor cells, mice were allowed a brief recovery period and then received s.c. injections of VEGF-Trap_{R1R2} (25 mg/kg) or vehicle twice weekly for the duration of the experiment (2–3.0 weeks), after which the

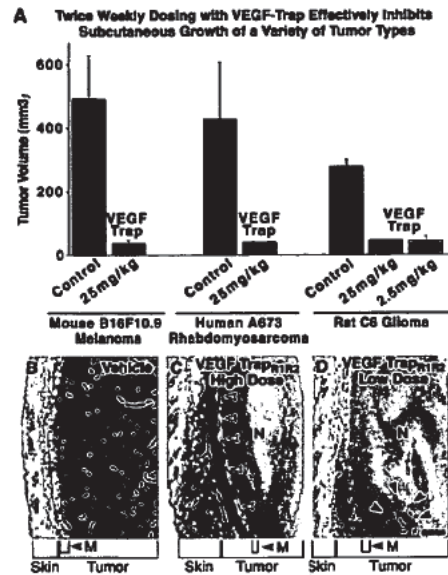

Fig. 4. VEGF-Trap_{R1R2} dramatically inhibits the s.c. growth and vascularity of implanted tumors from diverse tissues and species. (A) VEGF-Trap_{R1R2} substantially blocked the growth of the indicated s.c. implanted tumors, at the indicated doses twice weekly for 2 weeks (C6 and B16F10.9) or 3.0 weeks (A673). Error bars represent standard error of mean, $n =$ five mice/treatment group. The differences between control tumor volumes and VEGF-Trap_{R1R2}-treated tumor volumes were analyzed by using Student's t tests and found to be significant at the following levels: B16F10 $P = 0.01$; A673 $P = 0.06$; C6 $P < 0.0001$. (B–D) Histological analysis reveals that VEGF-Trap_{R1R2} can effectively block blood vessel growth in these implanted tumors. Sections of C6 tumors stained with antibodies to platelet–endothelial cell adhesion molecule reveal that vehicle-treated animals had large tumors that were highly vascularized (B), whereas animals treated with 25 mg/kg VEGF-Trap_{R1R2} (C) had tumors that were largely avascular with large areas of necrosis (N). Viable tumor appeared to be vascularized because of cooption of preexisting host vessels (white arrowheads) associated with hypodermal musculature (M) and dermis. Treatment with 2.5 mg/kg VEGF-Trap_{R1R2} greatly stunted tumor growth (C) and resulted in large necrotic regions (N), although small pockets of vessels were occasionally apparent (black arrows). (Bar = 100 μ m.)

animals were killed and tumors excised and measured. VEGF-Trap_{R1R2} significantly inhibited the growth of all three types of tumors (Fig. 4A). In the study using C6 glioma cells, a 10-fold lower dose of VEGF-Trap_{R1R2} (2.5 mg/kg) was tested and found to be equally effective at inhibiting tumor growth.

To evaluate the effects of VEGF-Trap_{R1R2} on tumor-associated angiogenesis, the tumors from the above studies were sectioned and immunostained with antibodies to platelet–endothelial cell adhesion molecule, so that the vasculature could be visualized (Fig. 4B–D). This analysis revealed that the higher dose of VEGF-Trap_{R1R2} almost completely blocked tumor-associated angiogenesis, with the stunted tumors being largely avascular, save for regions in which preexisting host vessels appeared to be coopted by surrounding tumor (see open arrowheads, Fig. 4C). The lower dose of VEGF-Trap_{R1R2}, which was quite comparable at inhibiting tumor growth (see above), appeared to be slightly less effective at completely blocking tumor-associated angiogenesis, allowing for small pockets of tumor-associated vessels in otherwise avascular tumors (see black arrowheads in Fig. 4D). In contrast to the VEGF-Trap-treated tumors, control tumors in vehicle-treated mice not only were much larger (see above) but also had a very high vascular density (Fig. 4B).

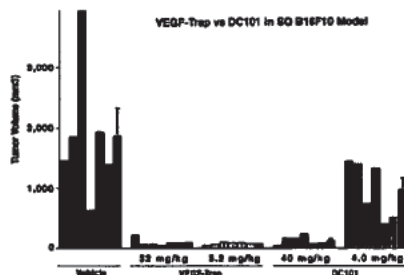

Fig. 5. VEGF-Trap_{R1R2} blocks tumor growth (of subcutaneously implanted B16F10.9 cells) at far lower concentrations than DC101, a monoclonal antibody directed to VEGFR2. Mice were treated twice weekly with the indicated dose of VEGF-Trap_{R1R2}, DC101, or vehicle. After 2.5 weeks, mice were killed, and tumors were excised and measured. Individual tumor volumes are shown (colored bars), as are average tumor volumes for each treatment (black bars) \pm SEM, $n =$ six mice/treatment group. Differences between treatment groups were analyzed by using a one-way ANOVA followed by Fisher's protected least significant difference test. Average volume of tumors in all treatment groups is significantly smaller than control tumor volume ($P < 0.01$). Differences in tumor volume between the high-dose VEGF-Trap, low-dose VEGF-Trap, and high-dose DC101 treatment groups are not significantly different, but they are significantly different from those of the low-dose DC101 treatment group ($P < 0.02$).

VEGF-Trap_{R1R2} Compares Favorably with Antibodies Targeting VEGFR2.

After establishing that VEGF-Trap_{R1R2} was effective at blocking s.c. tumor growth, we undertook studies to compare its efficacy with other known VEGF blockers. One particularly effective and well-characterized blocker is a monoclonal antibody, termed DC101, that targets VEGFR2 (15). When equimolar doses of VEGF-Trap_{R1R2} and DC101 were compared in the B16F10 melanoma model, it was apparent that much higher doses of DC101 are required to inhibit tumor growth (Fig. 5). Furthermore, because antibodies have longer circulation times in mice than simple Fc fusion proteins, the highly efficacious dose of DC101 accumulates to approximately 60-fold higher serum levels than that of the equally efficacious low dose of VEGF-Trap: circulating levels of DC101 in animals treated with the 40-mg/kg dose were $2,442 \pm 272 \mu\text{g/ml}$, in contrast to the circulating levels of VEGF-Trap in animals treated with 3.2 mg/kg, which were $40 \pm 8 \mu\text{g/ml}$. Thus, circulating levels of VEGF-Trap that were approximately 60-fold lower than those of DC101 were equally efficacious in inhibiting tumor growth. Importantly, the favorable allometric scaling of Fc fusion proteins relative to antibodies (27, 28) suggests that in humans the circulation time for the VEGF-Trap will be much more comparable to that of antibodies, which in turn suggests that in humans the difference in efficacious doses would be further magnified and may be as great as 60-fold.

As described in an accompanying manuscript (29), when used at the same dose, VEGF-Trap shows efficacy equal to or better than a monoclonal antibody to VEGF (30). As noted above, because Fc fusion proteins have much shorter circulating half-lives than antibodies in mice, but comparable half-lives in humans, the finding that the VEGF-Trap_{R1R2} is at least as potent as the monoclonal antibody in mice suggests that the efficacious dose of VEGF-Trap will be much lower than that of the monoclonal antibody in humans.

Discussion

Validation of VEGF as an important new target in the war against cancer comes from pioneering clinical studies using a humanized monoclonal antibody that binds and blocks VEGF.[†] Because anti-VEGF approaches act by blocking tumor-associated angiogenesis, which appears to be widely required by many different types of tumors, these approaches may prove to be generally useful

against a wide assortment of cancers. In addition, pathological angiogenesis seems to contribute to a number of non-neoplastic diseases, such as diabetic retinopathy (31) and psoriasis (32), extending the potential utility of anti-VEGF therapeutics. All this promise highlights the need to optimize anti-VEGF approaches. Herein we describe the engineering of an anti-VEGF agent, termed VEGF-Trap_{R1R2}. VEGF-Trap_{R1R2} is a derivative of perhaps the most potent VEGF binder known, VEGFR1. Soluble forms of VEGFR1 suffer from poor pharmacokinetic properties, which seem to correlate with their nonspecific interactions with extracellular matrix. VEGF-Trap_{R1R2} was engineered to have minimal interactions with extracellular matrix, and this property apparently accounts for its satisfying pharmacokinetic profile. The combination of high-affinity and improved pharmacokinetics apparently contributes toward making VEGF-Trap_{R1R2} one of the most, if not the most, potent and efficacious VEGF blocker available. An additional advantage is that VEGF-Trap_{R1R2} is composed of entirely human sequences, hopefully minimizing the possibility that it might prove immunogenic in human patients. Despite its wholly human nature, VEGF-Trap_{R1R2} binds all species of VEGF tested, from human to chicken VEGF (not shown), making it a very versatile reagent that can be used in almost any experimental animal models.

A recent study comparing numerous antiangiogenesis approaches concluded that anti-VEGF approaches were the most efficacious (11). The particular anti-VEGF agent used for these studies was essentially equivalent to our parental VEGF-Trap but was delivered in an adenoviral system in which it was highly expressed in the livers of infected animals. In contrast to other anti-VEGF approaches that seem to be well-tolerated, the adenovirally delivered VEGF-Trap caused severe liver toxicity and ascites, raising the possibility that it might have some unique mechanism-based side effects compared with other anti-VEGF approaches. To explore this possibility, we made adenoviral versions of both the parental VEGF-Trap as well as VEGF-Trap_{R1R2} and found that, whereas adenoviral delivery of parental VEGF-Trap reproduces the previously reported toxicities (11), adenoviral delivery of VEGF-Trap_{R1R2} did not cause these side effects even though much higher levels were achieved in the circulation. Our conclusion is that the nonspecific interactions of the parental VEGF-Trap with extracellular matrix contribute to its increased toxicity after adenoviral administration, and that comparable toxicity is not noted with adenoviral administration of the engineered VEGF-Trap_{R1R2}.

In addition to the anticancer findings reported here, recent studies have shown that various versions of the VEGF-Trap can efficaciously treat a cancer-associated condition in mice similar to liver peliosis (33), as well as noncancer-associated disease models, such as of diabetic retinopathy (34–36) and psoriasis (Y.-P. Xia, M. Detmar, G.D.Y., and J.S.R., unpublished results). The accompanying manuscript (29) compares the efficacy of the VEGF-Trap to that of several other VEGF blockers, including a humanized monoclonal antibody to VEGF, in a model of kidney cancer. Among the several VEGF blockers tested, the VEGF-Trap shows the best overall efficacy. In this manuscript, we compare the efficacy of the VEGF-Trap to that of a monoclonal antibody to VEGFR2 in cancer models and find that far lower circulating levels of VEGF-Trap_{R1R2} are required for similar efficacy. Tumors treated with highest doses of the VEGF-Trap are not only stunted but also strikingly avascular. Our description of a VEGF blocker with such superior blocking and pharmacologic properties seems to demand that it be tested in human patients suffering from diseases involving neoangiogenesis. Toward this end, the safety of the VEGF-Trap has recently been confirmed in toxicological studies in cynomolgus monkeys (data not shown). Consequently, the VEGF-Trap is currently in human clinical trials for several different types of cancer.

We thank the following for their support: A. Rafique, B. Luan, S. Keerthy, A. Polotskaia, S. Mahon, S. Xu, M. Fezoui, S. Jiang,

L. Pasnikowski, V. Mosher, H. Collins, J. Kintner, L. Kasselmann, and Q. Zhang. We also thank S. Staton and V. Lan for image processing.

1. Ferrara, N. & Alitalo, K. (1999) *Nat. Med.* **5**, 1359–1364.
2. Folkman, J. (1995) *Nat. Med.* **1**, 27–31.
3. Holash, J., Wiegand, S. J. & Yancopoulos, G. D. (1999) *Oncogene* **18**, 5356–5362.
4. Pezzella, F., Pastorino, U., Tagliabue, E., Andreola, S., Sozzi, G., Gasparini, G., Menard, S., Gatter, K. C., Harris, A. L., Fox, S., *et al.* (1997) *Am. J. Pathol.* **151**, 1417–1423.
5. Zagzag, D., Friedlander, D. R., Margolis, B., Grumet, M., Semenza, G. L., Zhong, H., Simons, J. W., Holash, J., Wiegand, S. J. & Yancopoulos, G. D. (2000) *Pediatr. Neurosurg.* **33**, 49–55.
6. Zagzag, D., Amirmovin, R., Greco, M. A., Yee, H., Holash, J., Wiegand, S. J., Zabski, S., Yancopoulos, G. D. & Grumet, M. (2000) *Lab. Invest.* **80**, 837–849.
7. van Hinsbergh, V. W., Collen, A. & Koolwijk, P. (1999) *Ann. Oncol.* **10**, 60–63.
8. Eriksson, U. & Alitalo, K. (1999) *Curr. Top. Microbiol. Immunol.* **237**, 41–57.
9. Ferrara, N. (1999) *Curr. Top. Microbiol. Immunol.* **237**, 1–30.
10. Yancopoulos, G. D., Davis, S., Gale, N. W., Rudge, J. S., Wiegand, S. J. & Holash, J. (2000) *Nature (London)* **407**, 242–248.
11. Kuo, C. J., Farnebo, F., Yu, E. Y., Christofferson, R., Swearingen, R. A., Carter, R., von Recum, H. A., Yuan, J., Kamihara, J., Flynn, E., *et al.* (2001) *Proc. Natl. Acad. Sci. USA* **98**, 4605–4610.
12. Kim, K. J., Li, B., Winer, J., Armanini, M., Gillett, N., Phillips, H. S. & Ferrara, N. (1993) *Nature (London)* **362**, 841–844.
13. Asano, M., Yukita, A., Matsumoto, T., Hanatani, M. & Suzuki, H. (1998) *Hybridoma* **17**, 185–190.
14. Kamiya, K., Konno, H., Tanaka, T., Baba, M., Matsumoto, K., Sakaguchi, T., Yukita, A., Asano, M., Suzuki, H., Arai, T. & Nakamura, S. (1999) *Jpn. J. Cancer Res.* **90**, 794–800.
15. Prewett, M., Huber, J., Li, Y., Santiago, A., O'Connor, W., King, K., Overholser, J., Hooper, A., Pytowski, B., Witte, L., Bohlen, P. & Hicklin, D. J. (1999) *Cancer Res.* **59**, 5209–5218.
16. Ferrara, N., Chen, H., Davis-Smyth, T., Gerber, H. P., Nguyen, T. N., Peccers, D., Chisholm, V., Hillan, K. J. & Schwall, R. H. (1998) *Nat. Med.* **4**, 336–340.
17. Gerber, H. P., Vu, T. H., Ryan, A. M., Kowalski, J., Werb, Z. & Ferrara, N. (1999) *Nat. Med.* **5**, 623–628.
18. Gerber, H. P., Hillan, K. J., Ryan, A. M., Kowalski, J., Keller, G. A., Rangell, L., Wright, B. D., Radtke, F., Aguett, M. & Ferrara, N. (1999) *Development (Cambridge, U.K.)* **126**, 1149–1159.
19. Goldman, C. K., Kendall, R. L., Cabrera, G., Soroceanu, L., Heike, Y., Gillespie, G. Y., Siegal, G. P., Mao, X., Bett, A. J., Huckle, W. R., *et al.* (1998) *Proc. Natl. Acad. Sci. USA* **95**, 8795–8800.
20. Millauer, B., Longhi, M. P., Plate, K. H., Shawver, L. K., Risau, W., Ullrich, A. & Strawn, L. M. (1996) *Cancer Res.* **56**, 1615–1620.
21. Fong, T. A., Shawver, L. K., Sun, L., Tang, C., App, H., Powell, T. J., Kim, Y. H., Schreck, R., Wang, X., Risau, W., *et al.* (1999) *Cancer Res.* **59**, 99–106.
22. Dreves, J., Hofmann, I., Hugenschmidt, H., Wittig, C., Madjar, H., Muller, M., Wood, J., Martiny-Baron, G., Unger, C. & Marme, D. (2000) *Cancer Res.* **60**, 4819–4824.
23. Wedge, S. R., Ogilvie, D. J., Dukes, M., Kendrew, J., Curwen, J. O., Hennequin, L. F., Thomas, A. P., Stokes, E. S., Curry, B., Richmond, G. H., *et al.* (2000) *Cancer Res.* **60**, 970–975.
24. Gerber, H. P., Kowalski, J., Sherman, D., Eberhard, D. A. & Ferrara, N. (2000) *Cancer Res.* **60**, 6253–6258.
25. Holash, J., Maisonpierre, P. C., Compton, D., Boland, P., Alexander, C. R., Zagzag, D., Yancopoulos, G. D. & Wiegand, S. J. (1999) *Science* **284**, 1994–1998.
26. Lu, D., Kussie, P., Pytowski, B., Persaud, K., Bohlen, P., Witte, L. & Zhu, Z. (2000) *J. Biol. Chem.* **275**, 14321–14330.
27. Mordenti, J. & Green, J. D. (1991) in *New Trends in Pharmacokinetics*, eds Rescigno, A. & Thakur, A. K. (Plenum, New York), pp. 411–424.
28. Lin, Y. S., Nguyen, C., Mendoza, J. L., Escandon, E., Fei, D., Meng, Y. G. & Modi, N. B. (1999) *J. Pharmacol. Exp. Ther.* **288**, 371–378.
29. Kim, E. S., Serur, A., Huang, J., Manley, C. A., McCrudden, K. W., Frischer, J. S., Soffer, S. Z., Ring, L., New, T., Zabski, S., *et al.* (2002) *Proc. Natl. Acad. Sci. USA* **99**, 11399–11404.
30. Mordenti, J., Thomsen, K., Licko, V., Chen, H., Meng, Y. G. & Ferrara, N. (1999) *Toxicol. Pathol.* **27**, 14–21.
31. Adamis, A. P., Miller, J. W., Bernal, M. T., D'Amico, D. J., Folkman, J., Yeo, T. K. & Yeo, K. T. (1994) *Am. J. Ophthalmol.* **118**, 445–450.
32. Detmar, M., Brown, L. F., Claffey, K. P., Yeo, K. T., Koehler, O., Jackman, R. W., Berse, B. & Dvorak, H. F. (1994) *J. Exp. Med.* **180**, 1141–1146.
33. Wong, A. K., Alfert, M., Castrillon, D. H., Shen, Q., Holash, J., Yancopoulos, G. D. & Chin, L. (2001) *Proc. Natl. Acad. Sci. USA* **98**, 7481–7486.
34. Jousseaume, A. M., Poulaki, V., Qin, W., Kirchhof, B., Mitsiades, N., Wiegand, S. J., Rudge, J., Yancopoulos, G. D. & Adamis, A. P. (2002) *Am. J. Pathol.* **160**, 501–509.
35. Poulaki, V., Qin, W., Jousseaume, A. M., Hurlbut, P., Wiegand, S. J., Rudge, J., Yancopoulos, G. D. & Adamis, A. P. (2002) *J. Clin. Invest.* **109**, 805–815.
36. Qaum, T., Xu, Q., Jousseaume, A. M., Clemens, M. W., Qin, W., Miyamoto, K., Hassessian, H., Wiegand, S. J., Rudge, J., Yancopoulos, G. D. & Adamis, A. P. (2001) *Invest. Ophthalmol. Visual Sci.* **42**, 2408–2413.

ATTACHMENT H

Copy of IND-receipt Letter from FDA

Food and Drug Administration
Rockville, MD 20852

MAY 24 2005

Our Reference: BB-IND 12462

Regeneron Pharmaceutical Inc.
Attention: William G. Roberts, M.D.
Vice President, Regulatory Development
777 old Saw Mill River Road
Tarrytown, NY 10591

I RECEIVED JUN 1 - 2005

Dear Dr. Williams:

The Center for Drug Evaluation and Research has received your **Investigational New Drug Application (IND)**. The following product name and BB-IND number have been assigned to this application. They serve only to identify it and do not imply that this Center either endorses or does not endorse your application.

BB-IND #: 12462**SPONSOR: Regeneron Pharmaceutical Inc.****PRODUCT NAME: Vascular Endothelial Growth Factor Fc Protein (human, recombinant, CHO cells, Regeneron)****DATE OF SUBMISSION: May 13, 2005****DATE OF RECEIPT: May 16, 2005**

This BB-IND number should be used to identify all future correspondence and submissions, as well as telephone inquiries concerning this IND. Please provide an **original and two copies of every submission to this file**. Please include three originals of all illustrations which do not reproduce well.

It is understood that studies in humans will not be initiated until 30 days after the date of receipt shown above. If this office notifies you, verbally or in writing, of serious deficiencies that require correction before human studies can begin, it is understood that you will continue to withhold such studies until you are notified that the material you have submitted to correct the deficiencies is satisfactory. If such a clinical hold is placed on this file, you will be notified in writing of the reasons for placing the IND on hold.

You are responsible for compliance with applicable portions of the Public Health Service Act, the Federal Food, Drug, and Cosmetic Act, and the Code of Federal Regulations (CFR). A copy of 21 CFR Part 312, pertaining to INDs, is enclosed. Copies of other pertinent regulations are available from this Center upon request. The following points regarding obligations of an IND sponsor are included for your information only, and are not intended to be comprehensive.

Progress reports are required at intervals not exceeding one year and are due within 60 days of the anniversary of the date that the IND went into effect [21 CFR 312.33]. Any unexpected fatal or immediately life-threatening reaction associated with use of this product must be reported to this Division by telephone or facsimile transmission no later than seven calendar days after initial receipt of the information. All serious, unexpected adverse experiences, as well as results from animal studies that suggest significant clinical risk, must be reported, in writing, to this Division and to all investigators within fifteen calendar days after initial receipt of this information [21 CFR 312.32].

As required by the Food and Drug Modernization Act and the Best Pharmaceuticals for Children Act, you are also responsible for registering certain clinical trials involving your drug product in the Clinical Trials Data Bank <http://clinicaltrials.gov/> and <http://prsinfo.clinicaltrials.gov/>. If your drug is intended for the treatment of a serious or life-threatening disease or condition and you are conducting clinical trials to test its effectiveness, then you must register these trials in the Data Bank. Although not required, we encourage you to register effectiveness trials for non-serious diseases or conditions as well as non-effectiveness trials for all diseases or conditions, whether or not they are serious or life-threatening. Additional information on registering your clinical trials, including the required and optional data elements and the FDA Draft Guidance for Industry, "Information Program on Clinical Trials for Serious or Life-Threatening Diseases and Conditions," is available at the Protocol Registration System (PRS) Information Site <http://prsinfo.clinicaltrials.gov/>.

Charging for an investigational product in a clinical trial under an IND is not permitted without the prior written approval of the FDA.

Prior to use of each new lot of the investigational biologic in clinical trials, please submit the lot number, the results of all tests performed on the lot, and the specifications when established (i.e., the range of acceptable results).

If not included in your submission, please provide copies of the consent forms for each clinical study. A copy of the requirements for and elements of informed consent are enclosed. Also, please provide documentation of the institutional review board approval(s) for each clinical study.

All laboratory or animal studies intended to support the safety of this product should be conducted in compliance with the regulations for "Good Laboratory Practice for Nonclinical Laboratory Studies" (21 CFR Part 58, copies available upon request). If such studies have not been conducted in compliance with these regulations, please provide a statement describing in detail all differences between the practices used and those required in the regulations.

Item 7a of form FDA 1571 requests that either an "environmental assessment," or a "claim for categorical exclusion" from the requirements for environmental assessment, be included in the IND. If you did not include a response to this item with your application, please submit one. See the enclosed information sheet for additional information on how these requirements may be addressed.

Please refer to <http://www.fda.gov/cder/biologics/default.htm> for important information regarding therapeutic biological products, including the addresses for submissions. Effective Oct. 4, 2004, the new address for all submissions to this application is:

CDER Therapeutic Biological Products Document Room
Center for Drug Evaluation and Research
Food and Drug Administration
12229 Wilkins Avenue
Rockville, Maryland 20852

Telephone inquiries concerning this IND should be made directly to me at (301) 827-4358. If we have any comments after we have reviewed this submission, we will contact you.

Sincerely yours,



Florence O. Moore, M.S.
Regulatory Project Manager
Division of Review Management and Policy
Office of Drug Evaluation VI
Center for Drug Evaluation and Research

Enclosures (3): 21 CFR Part 312
21 CFR 50.20, 50.25
Information sheet on 21 CFR 25.24

§ 50.20 General requirements for informed consent.

Except as provided in §§ 50.23 and 50.24, no investigator may involve a human being as a subject in research covered by these regulations unless the investigator has obtained the legally effective informed consent of the subject or the subject's legally authorized representative. An investigator shall seek such consent only under circumstances that provide the prospective subject or the representative sufficient opportunity to consider whether or not to participate and that minimize the possibility of coercion or undue influence. The information that is given to the subject or the representative shall be in language understandable to the subject or the representative. No informed consent, whether oral or written, may include any exculpatory language through which the subject or the representative is made to waive or appear to waive any of the subject's legal rights, or releases or appears to release the investigator, the sponsor, the institution, or its agents from liability for negligence.

[49 FR 8951, Jan. 27, 1981, as amended at 64 FR 10942, Mar. 8, 1999]

§ 50.25 Elements of informed consent.

(a) *Basic elements of informed consent.* In seeking informed consent, the following information shall be provided to each subject:

(1) A statement that the study involves research, an explanation of the purposes of the research and the expected duration of the subject's participation, a description of the procedures to be followed, and identification of any procedures which are experimental.

(2) A description of any reasonably foreseeable risks or discomforts to the subject.

(3) A description of any benefits to the subject or to others which may reasonably be expected from the research.

(4) A disclosure of appropriate alternative procedures or courses of treatment, if any, that might be advantageous to the subject.

(5) A statement describing the extent, if any, to which confidentiality of records identifying the subject will be maintained and that notes the possibility that the Food and Drug Administration may inspect the records.

(6) For research involving more than minimal risk, an explanation as to whether any compensation and an explanation as to whether any medical treatments are available if injury occurs and, if so, what they consist of, or where further information may be obtained.

(7) An explanation of whom to contact for answers to pertinent questions about the research and research subjects' rights, and whom to contact in the event of a research-related injury to the subject.

(8) A statement that participation is voluntary, that refusal to participate will involve no penalty or loss of benefits to which the subject is otherwise entitled, and that the subject may discontinue participation at any time without penalty or loss of benefits to which the subject is otherwise entitled.

(b) *Additional elements of informed consent.* When appropriate, one or more of the following elements of information shall also be provided to each subject:

(1) A statement that the particular treatment or procedure may involve risks to the subject (or to the embryo or fetus, if the subject is or may become pregnant) which are currently unforeseeable.

(2) Anticipated circumstances under which the subject's participation may be terminated by the investigator without regard to the subject's consent.

(3) Any additional costs to the subject that may result from participation in the research.

(4) The consequences of a subject's decision to withdraw from the research and procedures for orderly termination of participation by the subject.

(5) A statement that significant new findings developed during the course of the research which may relate to the subject's willingness to continue participation will be provided to the subject.

(6) The approximate number of subjects involved in the study.

(c) The informed consent requirements in these regulations are not intended to preempt any applicable Federal, State, or local laws which require additional information to be disclosed for informed consent to be legally effective.

(d) Nothing in these regulations is intended to limit the authority of a physician to provide emergency medical care to the extent the physician is permitted to do so under applicable Federal, State, or local law.

Information Sheet for a Claim of Categorical
Exclusion for an IND Under 21 CFR 25.24

For those wastes generated in the production and use of the product which will be controlled, please include documentation that such waste storage or disposal is in compliance with federal, state and local requirements for hazardous waste production. As an alternative, identify any generally recognized, scientifically sound control procedures which have been implemented to reduce the likelihood of inadvertent release of potentially toxic materials into the environment (e.g., compliance with the NIH Guidelines for Research Involving Recombinant DNA Molecules [51 FR 16958 (1986)] and/or compliance with the EPA Effluent Guidelines and Standards for Pharmaceutical Manufacturing [40 CFR 439]). If these alternatives are not applicable, a description of the control procedures actually used to prevent waste from entering the environment should be submitted.

For those wastes generated in the production and use of the product which will not be controlled, please list the potentially toxic waste compounds, including the quantities and concentrations which may be expected to enter the environment from both productions of the product and from the intended clinical studies, and briefly describe the immediate environment into which such release will occur. Further, provide the appropriate references or experimental data from which it may be reasonably concluded that such release is non-toxic.

If the waste to be generated during the production and proposed investigational use of this product is either not controlled or is not reasonably expected to be non-toxic in the environment to which it will be released, please submit an environmental assessment using the format described in 21 CFR 25.31.

If actions under proposed amendments to this IND substantially alter the quantity, quality or conditions of waste release in such a way as to alter the basis for either a claim of categorical exclusion or an environmental assessment, then such amendments should be supported by the appropriate data for a claim of categorical exclusion or an amended environmental assessment for wastes generated under the proposed amendments to this IND.

An Investigator sponsored IND for which no additional product manufacturing is intended will ordinarily have addressed these environmental issues by incorporating the manufacturer's IND or MF by cross reference. However, if the use of the product during clinical investigation is expected to result in the uncontrolled release of toxic materials into the environment then an environmental assessment should be submitted.

3/30/94

for marketing. In the absence of an approved new drug application or abbreviated new drug application, such product is also misbranded under section 502 of the act.

(c) Clinical investigations designed to obtain evidence that any drug product labeled, represented, or promoted for OTC use for the treatment and/or prevention of nocturnal leg muscle cramps is safe and effective for the purpose intended must comply with the requirements and procedures governing the use of investigational new drugs set forth in part 312 of this chapter.

(d) After February 22, 1995, any such OTC drug product initially introduced or initially delivered for introduction into interstate commerce that is not in compliance with this section is subject to regulatory action.

(59 FR 43352, Aug. 22, 1994)

§310.547 Drug products containing quinine, offered over-the-counter (OTC) for the treatment and/or prevention of malaria.

(a) Quinine and quinine salts have been used OTC for the treatment and/or prevention of malaria, a serious and potentially life-threatening disease. Quinine is no longer the drug of choice for the treatment and/or prevention of most types of malaria. In addition, there are serious and complicating aspects of the disease itself and some potentially serious and life-threatening risks associated with the use of quinine at doses employed for the treatment of malaria. There is a lack of adequate data to establish general recognition of the safety of quinine drug products for OTC use in the treatment and/or prevention of malaria. Therefore, quinine or quinine salts cannot be safely and effectively used for the treatment and/or prevention of malaria except under the care and supervision of a doctor.

(b) Any OTC drug product containing quinine or quinine salts that is labeled, represented, or promoted for the treatment and/or prevention of malaria is regarded as a new drug within the meaning of section 201(p) of the act, for which an approved application or abbreviated application under section 505 of the act and part 314 of this chapter is required for marketing. In the absence of a approved new drug applica-

tion or abbreviated new drug application, such product is also misbranded under section 502 of the act.

(c) Clinical investigations designed to obtain evidence that any drug product labeled, represented, or promoted for OTC use for the treatment and/or prevention of malaria is safe and effective for the purpose intended must comply with the requirements and procedures governing the use of investigational new drugs set forth in part 312 of this chapter.

(d) After April 20, 1998, any such OTC drug product initially introduced or initially delivered for introduction into interstate commerce that is not in compliance with this section is subject to regulatory action.

(63 FR 13528, Mar. 20, 1998)

PART 312—INVESTIGATIONAL NEW DRUG APPLICATION

Subpart A—General Provisions

- Sec.
- 312.1 Scope.
- 312.2 Applicability.
- 312.3 Definitions and interpretations.
- 312.5 Labeling of an investigational new drug.
- 312.7 Promotion and charging for investigational drugs.
- 312.10 Waivers.

Subpart B—Investigational New Drug Application (IND)

- 312.20 Requirement for an IND.
- 312.21 Phases of an investigation.
- 312.22 General principles of the IND submission.
- 312.23 IND content and format.
- 312.30 Protocol amendments.
- 312.31 Information amendments.
- 312.32 IND safety reports.
- 312.33 Annual reports.
- 312.34 Treatment use of an investigational new drug.
- 312.35 Submissions for treatment use.
- 312.36 Emergency use of an investigational new drug.
- 312.38 Withdrawal of an IND.

Subpart C—Administrative Actions

- 312.40 General requirements for use of an investigational new drug in a clinical investigation.
- 312.41 Comment and advice on an IND.
- 312.42 Clinical holds and requests for modification.

- 312.44 Termination.
- 312.45 Inertive status.
- 312.47 Meetings.
- 312.48 Dispute resolution.

Subpart D—Responsibilities of Sponsors and Investigators

- 312.50 General responsibilities of sponsors.
- 312.52 Transfer of obligations to a contract research organization.
- 312.53 Selecting investigators and monitors.
- 312.54 Emergency research under §50.24 of this chapter.
- 312.55 Informing investigators.
- 312.56 Review of ongoing investigations.
- 312.57 Recordkeeping and record retention.
- 312.58 Inspection of sponsor's records and reports.
- 312.59 Disposition of unused supply of investigational drug.
- 312.60 General responsibilities of investigators.
- 312.61 Control of the investigational drug.
- 312.62 Investigator recordkeeping and record retention.
- 312.64 Investigator reports.
- 312.66 Assurance of IRB review.
- 312.68 Inspection of investigator's records and reports.
- 312.69 Handling of controlled substances.
- 312.70 Disqualification of a clinical investigator.

Subpart E—Drugs Intended to Treat Life-Threatening and Severely-Debilitating Illnesses

- 312.80 Purpose.
- 312.81 Scope.
- 312.82 Early consultation.
- 312.83 Treatment protocols.
- 312.84 Risk-benefit analysis in review of marketing applications for drugs to treat life-threatening and severely-debilitating illnesses.
- 312.85 Phase 4 studies.
- 312.86 Focused FDA regulatory research.
- 312.87 Active monitoring of conduct and evaluation of clinical trials.
- 312.88 Safeguards for patient safety.

Subpart F—Miscellaneous

- 312.110 Import and export requirements.
- 312.120 Foreign clinical studies not conducted under an IND.
- 312.130 Availability for public disclosure of data and information in an IND.
- 312.140 Address for correspondence.
- 312.145 Guidelines.

Subpart G—Drugs for Investigational Use in Laboratory Research Animals or in Vitro Tests

312.160 Drugs for investigational use in laboratory research animals or in vitro tests.

AUTHORITY: 21 U.S.C. 321, 331, 351, 352, 353, 355, 371; 42 U.S.C. 262.

SOURCE: 52 FR 8831, Mar. 19, 1987, unless otherwise noted.

Subpart A—General Provisions

§312.1 Scope.

(a) This part contains procedures and requirements governing the use of investigational new drugs, including procedures and requirements for the submission to, and review by, the Food and Drug Administration of investigational new drug applications (IND's). An investigational new drug for which an IND is in effect in accordance with this part is exempt from the premarketing approval requirements that are otherwise applicable and may be shipped lawfully for the purpose of conducting clinical investigations of that drug.

(b) References in this part to regulations in the Code of Federal Regulations are to chapter I of title 21, unless otherwise noted.

§312.2 Applicability.

(a) *Applicability.* Except as provided in this section, this part applies to all clinical investigations of products that are subject to section 505 of the Federal Food, Drug, and Cosmetic Act or to the licensing provisions of the Public Health Service Act (58 Stat. 632, as amended (42 U.S.C. 201 et seq.)).

(b) *Exemptions.* (1) The clinical investigation of a drug product that is lawfully marketed in the United States is exempt from the requirements of this part if all the following apply:

(i) The investigation is not intended to be reported to FDA as a well-controlled study in support of a new indication for use nor intended to be used to support any other significant change in the labeling for the drug;

(ii) If the drug that is undergoing investigation is lawfully marketed as a

prescription drug product, the investigation is not intended to support a significant change in the advertising for the product;

(iii) The investigation does not involve a route of administration or dosage level or use in a patient population or other factor that significantly increases the risks (or decreases the acceptability of the risks) associated with the use of the drug product;

(iv) The investigation is conducted in compliance with the requirements for institutional review set forth in part 56 and with the requirements for informed consent set forth in part 50; and

(v) The investigation is conducted in compliance with the requirements of §312.7.

(2)(i) A clinical investigation involving an in vitro diagnostic biological product listed in paragraph (b)(2)(ii) of this section is exempt from the requirements of this part if (a) it is intended to be used in a diagnostic procedure that confirms the diagnosis made by another, medically established, diagnostic product or procedure and (b) it is shipped in compliance with §312.160.

(ii) In accordance with paragraph (b)(2)(i) of this section, the following products are exempt from the requirements of this part: (a) blood grouping serum; (b) reagent red blood cells; and (c) anti-human globulin.

(3) A drug intended solely for tests in vitro or in laboratory research animals is exempt from the requirements of this part if shipped in accordance with §312.160.

(4) FDA will not accept an application for an investigation that is exempt under the provisions of paragraph (b)(1) of this section.

(5) A clinical investigation involving use of a placebo is exempt from the requirements of this part if the investigation does not otherwise require submission of an IND.

(6) A clinical investigation involving an exception from informed consent under §50.24 of this chapter is not exempt from the requirements of this part.

(c) *Bioavailability studies.* The applicability of this part to in vivo bioavailability studies in humans is subject to the provisions of §320.31.

(d) *Unlabeled indication.* This part does not apply to the use in the practice of medicine for an unlabeled indication of a new drug product approved under part 314 or of a licensed biological product.

(e) *Guidance.* FDA may, on its own initiative, issue guidance on the applicability of this part to particular investigational uses of drugs. On request, FDA will advise on the applicability of this part to a planned clinical investigation.

[52 FR 8831, Mar. 19, 1987, as amended at 61 FR 51529, Oct. 2, 1996; 64 FR 401, Jan. 5, 1999]

EFFECTIVE DATE NOTE: At 64 FR 401, Jan. 5, 1999, §312.2 was amended by removing "or 507" from paragraph (a) and by removing "or antibiotic drug" from paragraph (d), effective May 20, 1999.

§312.3 Definitions and interpretations.

(a) The definitions and interpretations of terms contained in section 201 of the Act apply to those terms when used in this part:

(b) The following definitions of terms also apply to this part:

Act means the Federal Food, Drug, and Cosmetic Act (secs. 201-902, 52 Stat. 1040 *et seq.*, as amended (21 U.S.C. 301-392)).

Clinical investigation means any experiment in which a drug is administered or dispensed to, or used involving, one or more human subjects. For the purposes of this part, an experiment is any use of a drug except for the use of a marketed drug in the course of medical practice.

Contract research organization means a person that assumes, as an independent contractor with the sponsor, one or more of the obligations of a sponsor, e.g., design of a protocol, selection or monitoring of investigations, evaluation of reports, and preparation of materials to be submitted to the Food and Drug Administration.

FDA means the Food and Drug Administration.

IND means an investigational new drug application. For purposes of this part, "IND" is synonymous with "Notice of Claimed Investigational Exemption for a New Drug."

Investigational new drug means a new

drug or biological drug that is used in a clinical investigation. The term also includes a biological product that is used in vitro for diagnostic purposes. The terms "investigational drug" and "investigational new drug" are deemed to be synonymous for purposes of this part.

Investigator means an individual who actually conducts a clinical investigation (i.e., under whose immediate direction the drug is administered or dispensed to a subject). In the event an investigation is conducted by a team of individuals, the investigator is the responsible leader of the team. "Sub-investigator" includes any other individual member of that team.

Marketing application means an application for a new drug submitted under section 305(b) of the Act or a product license application for a biological product submitted under the Public Health Service Act.

Sponsor means a person who takes responsibility for and initiates a clinical investigation. The sponsor may be an individual or pharmaceutical company, governmental agency, academic institution, private organization, or other organization. The sponsor does not actually conduct the investigation unless the sponsor is a sponsor-investigator. A person other than an individual that uses one or more of its own employees to conduct an investigation that it has initiated is a sponsor, not a sponsor-investigator, and the employees are investigators.

Sponsor-investigator means an individual who both initiates and conducts an investigation, and under whose immediate direction the investigational drug is administered or dispensed. The term does not include any person other than an individual. The requirements applicable to a sponsor-investigator under this part include both those applicable to an investigator and a sponsor.

Subject means a human who participates in an investigation, either as a recipient of the investigational new drug or as a control. A subject may be a healthy human or a patient with a disease.

[52 FR 8831, Mar. 19, 1987, as amended at 64 FR 401, Jan. 5, 1999]

EFFECTIVE DATE NOTE: At 64 FR 401, Jan. 5, 1999, §312.3 was amended by removing "antibiotic drug," from the paragraph defining "investigational new drug" and by removing the phrase "a request to provide for certification of an antibiotic submitted under section 507 of the Act," from the paragraph defining "Marketing application", effective May 20, 1999.

§312.6 Labeling of an investigational new drug.

(a) The immediate package of an investigational new drug intended for human use shall bear a label with the statement "Caution: New Drug—Limited by Federal (or United States) law to investigational use."

(b) The label or labeling of an investigational new drug shall not bear any statement that is false or misleading in any particular and shall not represent that the investigational new drug is safe or effective for the purposes for which it is being investigated.

§312.7 Promotion and charging for investigational drugs.

(a) *Promotion of an investigational new drug.* A sponsor or investigator, or any person acting on behalf of a sponsor or investigator, shall not represent in a promotional context that an investigational new drug is safe or effective for the purposes for which it is under investigation or otherwise promotes the drug. This provision is not intended to restrict the full exchange of scientific information concerning the drug, including dissemination of scientific findings in scientific or lay media. Rather, its intent is to restrict promotional claims of safety or effectiveness of the drug for a use for which it is under investigation and to preclude commercialization of the drug before it is approved for commercial distribution.

(b) *Commercial distribution of an investigational new drug.* A sponsor or investigator shall not commercially distribute or test market an investigational new drug.

(c) *Prolonging an investigation.* A sponsor shall not unduly prolong an investigation after finding that the results of the investigation appear to establish sufficient data to support a marketing application.

(d) *Charging for and commercialization of investigational drugs*—(1) *Clinical trials under an IND*. Charging for an investigational drug in a clinical trial under an IND is not permitted without the prior written approval of FDA. In requesting such approval, the sponsor shall provide a full written explanation of why charging is necessary in order for the sponsor to undertake or continue the clinical trial, e.g., why distribution of the drug to test subjects should not be considered part of the normal cost of doing business.

(2) *Treatment protocol or treatment IND*. A sponsor or investigator may charge for an investigational drug for a treatment use under a treatment protocol or treatment IND provided: (i) There is adequate enrollment in the ongoing clinical investigations under the authorized IND; (ii) charging does not constitute commercial marketing of a new drug for which a marketing application has not been approved; (iii) the drug is not being commercially promoted or advertised; and (iv) the sponsor of the drug is actively pursuing marketing approval with due diligence. FDA must be notified in writing in advance of commencing any such charges, in an information amendment submitted under §312.31. Authorization for charging goes into effect automatically 30 days after receipt by FDA of the information amendment, unless the sponsor is notified to the contrary.

(3) *Noncommercialization of investigational drug*. Under this section, the sponsor may not commercialize an investigational drug by charging a price larger than that necessary to recover costs of manufacture, research, development, and handling of the investigational drug.

(4) *Withdrawal of authorization*. Authorization to charge for an investigational drug under this section may be withdrawn by FDA if the agency finds that the conditions underlying the authorization are no longer satisfied.

(Collection of information requirements approved by the Office of Management and Budget under control number 0910-0014)

[52 FR 8831, Mar. 19, 1987, as amended at 52 FR 19476, May 7, 1987]

§312.10 Waivers.

(a) A sponsor may request FDA to waive applicable requirement under this part. A waiver request may be submitted either in an IND or in an information amendment to an IND. In an emergency, a request may be made by telephone or other rapid communication means. A waiver request is required to contain at least one of the following:

(1) An explanation why the sponsor's compliance with the requirement is unnecessary or cannot be achieved;

(2) A description of an alternative submission or course of action that satisfies the purpose of the requirement; or

(3) Other information justifying a waiver.

(b) FDA may grant a waiver if it finds that the sponsor's noncompliance would not pose a significant and unreasonable risk to human subjects of the investigation and that one of the following is met:

(1) The sponsor's compliance with the requirement is unnecessary for the agency to evaluate the application, or compliance cannot be achieved;

(2) The sponsor's proposed alternative satisfies the requirement; or

(3) The applicant's submission otherwise justifies a waiver.

(Collection of information requirements approved by the Office of Management and Budget under control number 0910-0014)

[52 FR 8831, Mar. 19, 1987, as amended at 52 FR 23031, June 17, 1987]

Subpart B—Investigational New Drug Application (IND)

§312.20 Requirement for an IND.

(a) A sponsor shall submit an IND to FDA if the sponsor intends to conduct a clinical investigation with an investigational new drug that is subject to §312.2(a).

(b) A sponsor shall not begin a clinical investigation subject to §312.2(a) until the investigation is subject to an IND which is in effect in accordance with §312.40.

(c) A sponsor shall submit a separate IND for any clinical investigation involving an exception from informed consent under §50.24 of this chapter.

Such a clinical investigation is not permitted to proceed without the prior written authorization from FDA. FDA shall provide a written determination 30 days after FDA receives the IND or earlier.

[52 FR 8831, Mar. 19, 1987, as amended at 61 FR 51529, Oct. 2, 1996; 62 FR 32479, June 16, 1997]

§312.21 Phases of an investigation.

An IND may be submitted for one or more phases of an investigation. The clinical investigation of a previously untested drug is generally divided into three phases. Although in general the phases are conducted sequentially, they may overlap. These three phases of an investigation are as follows:

(a) *Phase 1*. (1) Phase 1 includes the initial introduction of an investigational new drug into humans. Phase 1 studies are typically closely monitored and may be conducted in patients or normal volunteer subjects. These studies are designed to determine the metabolism and pharmacologic actions of the drug in humans, the side effects associated with increasing doses, and, if possible, to gain early evidence on effectiveness. During Phase 1, sufficient information about the drug's pharmacokinetics and pharmacological effects should be obtained to permit the design of well-controlled, scientifically valid, Phase 2 studies. The total number of subjects and patients included in Phase 1 studies varies with the drug, but is generally in the range of 20 to 80.

(2) Phase 1 studies also include studies of drug metabolism, structure-activity relationships, and mechanism of action in humans, as well as studies in which investigational drugs are used as research tools to explore biological phenomena or disease processes.

(b) *Phase 2*. Phase 2 includes the controlled clinical studies conducted to evaluate the effectiveness of the drug for a particular indication or indications in patients with the disease or condition under study and to determine the common short-term side effects and risks associated with the drug. Phase 2 studies are typically well controlled, closely monitored, and conducted in a relatively small number of patients, usually involving no more than several hundred subjects.

(c) *Phase 3*. Phase 3 studies are expanded controlled and uncontrolled trials. They are performed after preliminary evidence suggesting effectiveness of the drug has been obtained, and are intended to gather the additional information about effectiveness and safety that is needed to evaluate the overall benefit-risk relationship of the drug and to provide an adequate basis for physician labeling. Phase 3 studies usually include from several hundred to several thousand subjects.

§312.22 General principles of the IND submission.

(a) FDA's primary objectives in reviewing an IND are, in all phases of the investigation, to assure the safety and rights of subjects, and, in Phase 2 and 3, to help assure that the quality of the scientific evaluation of drugs is adequate to permit an evaluation of the drug's effectiveness and safety. Therefore, although FDA's review of Phase 1 submissions will focus on assessing the safety of Phase 1 investigations, FDA's review of Phases 2 and 3 submissions will also include an assessment of the scientific quality of the clinical investigations and the likelihood that the investigations will yield data capable of meeting statutory standards for marketing approval.

(b) The amount of information on a particular drug that must be submitted in an IND to assure the accomplishment of the objectives described in paragraph (a) of this section depends upon such factors as the novelty of the drug, the extent to which it has been studied previously, the known or suspected risks, and the developmental phase of the drug.

(c) The central focus of the initial IND submission should be on the general investigational plan and the protocols for specific human studies. Subsequent amendments to the IND that contain new or revised protocols should build logically on previous submissions and should be supported by additional information, including the results of animal toxicology studies or other human studies as appropriate. Annual reports to the IND should serve as the focus for reporting the results of studies being conducted under the IND and

should update the general investigational plan for the coming year.

(d) The IND format set forth in §312.23 should be followed routinely by sponsors in the interest of fostering an efficient review of applications. Sponsors are expected to exercise considerable discretion, however, regarding the content of information submitted in each section, depending upon the kind of drug being studied and the nature of the available information. Section 312.23 outlines the information needed for a commercially sponsored IND for a new molecular entity. A sponsor-investigator who uses, as a research tool, an investigational new drug that is already subject to a manufacturer's IND or marketing application should follow the same general format, but ordinarily may, if authorized by the manufacturer, refer to the manufacturer's IND or marketing application in providing the technical information supporting the proposed clinical investigation. A sponsor-investigator who uses an investigational drug not subject to a manufacturer's IND or marketing application is ordinarily required to submit all technical information supporting the IND, unless such information may be referenced from the scientific literature.

§312.23 IND content and format.

(a) A sponsor who intends to conduct a clinical investigation subject to this part shall submit an "Investigational New Drug Application" (IND) including, in the following order:

(1) *Cover sheet (Form FDA-1571)*. A cover sheet for the application containing the following:

(i) The name, address, and telephone number of the sponsor, the date of the application, and the name of the investigational new drug.

(ii) Identification of the phase or phases of the clinical investigation to be conducted.

(iii) A commitment not to begin clinical investigations until an IND covering the investigations is in effect.

(iv) A commitment that an Institutional Review Board (IRB) that complies with the requirements set forth in part 56 will be responsible for the initial and continuing review and approval of each of the studies in the pro-

posed clinical investigation and the investigator will report to the IRB proposed changes in the research activity in accordance with the requirements of part 56.

(v) A commitment to conduct the investigation in accordance with all other applicable regulatory requirements.

(vi) The name and title of the person responsible for monitoring the conduct and progress of the clinical investigations.

(vii) The name(s) and title(s) of the person(s) responsible under §312.32 for review and evaluation of information relevant to the safety of the drug.

(viii) If a sponsor has transferred any obligations for the conduct of any clinical study to a contract research organization, a statement containing the name and address of the contract research organization, identification of the clinical study, and a listing of the obligations transferred. If all obligations governing the conduct of the study have been transferred, a general statement of this transfer—in lieu of a listing of the specific obligations transferred—may be submitted.

(ix) The signature of the sponsor or the sponsor's authorized representative. If the person signing the application does not reside or have a place of business within the United States, the IND is required to contain the name and address of, and be countersigned by, an attorney, agent, or other authorized official who resides or maintains a place of business within the United States.

(2) *A table of contents.*

(3) *Introductory statement and general investigational plan.* (i) A brief introductory statement giving the name of the drug and all active ingredients, the drug's pharmacological class, the structural formula of the drug (if known), the formulation of the dosage form(s) to be used, the route of administration, and the broad objectives and planned duration of the proposed clinical investigation(s).

(ii) A brief summary of previous human experience with the drug, with reference to other IND's if pertinent, and to investigational or marketing experience in other countries that may

be relevant to the safety of the proposed clinical investigation(s).

(iii) If the drug has been withdrawn from investigation or marketing in any country for any reason related to safety or effectiveness, identification of the country(ies) where the drug was withdrawn and the reasons for the withdrawal.

(iv) A brief description of the overall plan for investigating the drug product for the following year. The plan should include the following: (a) The rationale for the drug or the research study; (b) the indication(s) to be studied; (c) the general approach to be followed in evaluating the drug; (d) the kinds of clinical trials to be conducted in the first year following the submission (if plans are not developed for the entire year, the sponsor should so indicate); (e) the estimated number of patients to be given the drug in those studies; and (f) any risks of particular severity or seriousness anticipated on the basis of the toxicological data in animals or prior studies in humans with the drug or related drugs.

(4) *(Reserved)*

(5) *Investigator's brochure.* If required under §312.55, a copy of the investigator's brochure, containing the following information:

(i) A brief description of the drug substance and the formulation, including the structural formula, if known.

(ii) A summary of the pharmacological and toxicological effects of the drug in animals and, to the extent known, in humans.

(iii) A summary of the pharmacokinetics and biological disposition of the drug in animals and, if known, in humans.

(iv) A summary of information relating to safety and effectiveness in humans obtained from prior clinical studies. (Reprints of published articles on such studies may be appended when useful.)

(v) A description of possible risks and side effects to be anticipated on the basis of prior experience with the drug under investigation or with related drugs, and of precautions or special monitoring to be done as part of the investigational use of the drug.

(6) *Protocols.* (i) A protocol for each study. (Protocols for studies

not submitted initially in the IND should be submitted in accordance with §312.30(a).) In general, protocols for Phase 1 studies may be less detailed and more flexible than protocols for Phase 2 and 3 studies. Phase 1 protocols should be directed primarily at providing an outline of the investigation—an estimate of the number of patients to be involved, a description of safety exclusions, and a description of the dosing plan including duration, dose, or method to be used in determining dose—and should specify in detail only those elements of the study that are critical to safety, such as necessary monitoring of vital signs and blood chemistries. Modifications of the experimental design of Phase 1 studies that do not affect critical safety assessments are required to be reported to FDA only in the annual report.

(ii) In Phases 2 and 3, detailed protocols describing all aspects of the study should be submitted. A protocol for a Phase 2 or 3 investigation should be designed in such a way that, if the sponsor anticipates that some deviation from the study design may become necessary as the investigation progresses, alternatives or contingencies to provide for such deviation are built into the protocols at the outset. For example, a protocol for a controlled short-term study might include a plan for an early crossover of nonresponders to an alternative therapy.

(iii) A protocol is required to contain the following, with the specific elements and detail of the protocol reflecting the above distinctions depending on the phase of study:

(a) A statement of the objectives and purpose of the study.

(b) The name and address and a statement of the qualifications (curriculum vitae or other statement of qualifications) of each investigator, and the name of each subinvestigator (e.g., research fellow, resident) working under the supervision of the investigator; the name and address of the research facilities to be used; and the name and address of each reviewing Institutional Review Board.

(c) The criteria for patient selection and for exclusion of patients and an estimate of the number of patients to be studied.

(d) A description of the design of the study, including the kind of control group to be used, if any, and a description of methods to be used to minimize bias on the part of subjects, investigators, and analysts.

(e) The method for determining the dose(s) to be administered, the planned maximum dosage, and the duration of individual patient exposure to the drug.

(f) A description of the observations and measurements to be made to fulfill the objectives of the study.

(g) A description of clinical procedures, laboratory tests, or other measures to be taken to monitor the effects of the drug in human subjects and to minimize risk.

(7) *Chemistry, manufacturing, and control information.* (i) As appropriate for the particular investigations covered by the IND, a section describing the composition, manufacture, and control of the drug substance and the drug product. Although in each phase of the investigation sufficient information is required to be submitted to assure the proper identification, quality, purity, and strength of the investigational drug, the amount of information needed to make that assurance will vary with the phase of the investigation, the proposed duration of the investigation, the dosage form, and the amount of information otherwise available. FDA recognizes that modifications to the method of preparation of the new drug substance and dosage form and changes in the dosage form itself are likely as the investigation progresses. Therefore, the emphasis in an initial Phase I submission should generally be placed on the identification and control of the raw materials and the new drug substance. Final specifications for the drug substance and drug product are not expected until the end of the investigational process.

(ii) It should be emphasized that the amount of information to be submitted depends upon the scope of the proposed clinical investigation. For example, although stability data are required in all phases of the IND to demonstrate that the new drug substance and drug product are within acceptable chemical and physical limits for the planned duration of proposed clinical inves-

tigation, if very short-term tests are proposed, the supporting stability data can be correspondingly limited.

(iii) As drug development proceeds and as the scale or production is changed from the pilot-scale production appropriate for the limited initial clinical investigations to the larger-scale production needed for expanded clinical trials, the sponsor should submit information amendments to supplement the initial information submitted on the chemistry, manufacturing, and control processes with information appropriate to the expanded scope of the investigation.

(iv) Reflecting the distinctions described in this paragraph (a)(7), and based on the phase(s) to be studied, the submission is required to contain the following:

(a) *Drug substance.* A description of the drug substance, including its physical, chemical, or biological characteristics; the name and address of its manufacturer; the general method of preparation of the drug substance; the acceptable limits and analytical methods used to assure the identity, strength, quality, and purity of the drug substance; and information sufficient to support stability of the drug substance during the toxicological studies and the planned clinical studies. Reference to the current edition of the United States Pharmacopeia—National Formulary may satisfy relevant requirements in this paragraph.

(b) *Drug product.* A list of all components, which may include reasonable alternatives for inactive compounds, used in the manufacture of the investigational drug product, including both those components intended to appear in the drug product and those which may not appear but which are used in the manufacturing process, and, where applicable, the quantitative composition of the investigational drug product, including any reasonable variations that may be expected during the investigational stage; the name and address of the drug product manufacturer; a brief general description of the manufacturing and packaging procedures as appropriate for the product; the acceptable limits and analytical methods used to assure the identity, strength, quality, and purity of the

drug product; and information sufficient to assure the product's stability during the planned clinical studies. Reference to the current edition of the United States Pharmacopeia—National Formulary may satisfy certain requirements in this paragraph.

(c) A brief general description of the composition, manufacture, and control of any placebo used in a controlled clinical trial.

(d) *Labeling.* A copy of all labels and labeling to be provided to each investigator.

(e) *Environmental analysis requirements.* A claim for categorical exclusion under § 25.30 or 25.31 or an environmental assessment under § 25.40.

(8) *Pharmacology and toxicology information.* Adequate information about pharmacological and toxicological studies of the drug involving laboratory animals or in vitro, on the basis of which the sponsor has concluded that it is reasonably safe to conduct the proposed clinical investigations. The kind, duration, and scope of animal and other tests required varies with the duration and nature of the proposed clinical investigations. Guidelines are available from FDA that describe ways in which these requirements may be met. Such information is required to include the identification and qualifications of the individuals who evaluated the results of such studies and concluded that it is reasonably safe to begin the proposed investigations and a statement of where the investigations were conducted and where the records are available for inspection. As drug development proceeds, the sponsor is required to submit informational amendments, as appropriate, with additional information pertinent to safety.

(i) *Pharmacology and drug disposition.* A section describing the pharmacological effects and mechanism(s) of action of the drug in animals, and information on the absorption, distribution, metabolism, and excretion of the drug, if known.

(ii) *Toxicology.* (a) An integrated summary of the toxicological effects of the drug in animals and in vitro. Depending on the nature of the drug and the phase of the investigation, the description is to include the results of acute, subacute, and chronic toxicity tests;

tests of the drug's effects on reproduction and the developing fetus; any special toxicity test related to the drug's particular mode of administration or conditions of use (e.g., inhalation, dermal, or ocular toxicology); and any in vitro studies intended to evaluate drug toxicity.

(b) For each toxicology study that is intended primarily to support the safety of the proposed clinical investigation, a full tabulation of data suitable for detailed review.

(iii) For each nonclinical laboratory study subject to the good laboratory practice regulations under part 58, a statement that the study was conducted in compliance with the good laboratory practice regulations in part 58, or, if the study was not conducted in compliance with those regulations, a brief statement of the reason for the noncompliance.

(9) *Previous human experience with the investigational drug.* A summary of previous human experience known to the applicant, if any, with the investigational drug. The information is required to include the following:

(i) If the investigational drug has been investigated or marketed previously, either in the United States or other countries, detailed information about such experience that is relevant to the safety of the proposed investigation or to the investigation's rationale. If the drug has been the subject of controlled trials, detailed information on such trials that is relevant to an assessment of the drug's effectiveness for the proposed investigational use(s) should also be provided. Any published material that is relevant to the safety of the proposed investigation or to an assessment of the drug's effectiveness for its proposed investigational use should be provided in full. Published material that is less directly relevant may be supplied by a bibliography.

(ii) If the drug is a combination of drugs previously investigated or marketed, the information required under paragraph (a)(9)(i) of this section should be provided for each active drug component. However, if any component in such combination is subject to an approved marketing application or is otherwise lawfully marketed in the

United States, the sponsor is not required to submit published material concerning that active drug component unless such material relates directly to the proposed investigational use (including publications relevant to component-component interaction).

(ii) If the drug has been marketed outside the United States, a list of the countries in which the drug has been marketed and a list of the countries in which the drug has been withdrawn from marketing for reasons potentially related to safety or effectiveness.

(10) *Additional information.* In certain applications, as described below, information on special topics may be needed. Such information shall be submitted in this section as follows:

(i) *Drug dependence and abuse potential.* If the drug is a psychotropic substance or otherwise has abuse potential, a section describing relevant clinical studies and experience and studies in test animals.

(ii) *Radioactive drugs.* If the drug is a radioactive drug, sufficient data from animal or human studies to allow a reasonable calculation of radiation-absorbed dose to the whole body and critical organs upon administration to a human subject. Phase 1 studies of radioactive drugs must include studies which will obtain sufficient data for dosimetry calculations.

(iii) *Pediatric studies.* Plans for assessing pediatric safety and effectiveness.

(iv) *Other information.* A brief statement of any other information that would aid evaluation of the proposed clinical investigations with respect to their safety or their design and potential as controlled clinical trials to support marketing of the drug.

(11) *Relevant information.* If requested by FDA, any other relevant information needed for review of the application.

(b) *Information previously submitted.* The sponsor ordinarily is not required to resubmit information previously submitted, but may incorporate the information by reference. A reference to information submitted previously must identify the file by name, reference number, volume, and page number where the information can be found. A reference to information submitted to the agency by a person other than the

sponsor is required to contain a written statement that authorizes the reference and that is signed by the person who submitted the information.

(c) *Material in a foreign language.* The sponsor shall submit an accurate and complete English translation of each part of the IND that is not in English. The sponsor shall also submit a copy of each original literature publication for which an English translation is submitted.

(d) *Number of copies.* The sponsor shall submit an original and two copies of all submissions to the IND file, including the original submission and all amendments and reports.

(e) *Numbering of IND submissions.* Each submission relating to an IND is required to be numbered serially using a single, three-digit serial number. The initial IND is required to be numbered 000; each subsequent submission (e.g., amendment, report, or correspondence) is required to be numbered chronologically in sequence.

(f) *Identification of exception from informed consent.* If the investigation involves an exception from informed consent under § 50.24 of this chapter, the sponsor shall prominently identify on the cover sheet that the investigation is subject to the requirements in § 50.24 of this chapter.

(Collection of information requirements approved by the Office of Management and Budget under control number 0910-0014)

[52 FR 8831, Mar. 19, 1987, as amended at 52 FR 23031, June 17, 1987; 53 FR 1918, Jan. 25, 1988; 61 FR 51529, Oct. 2, 1996; 62 FR 10599, July 29, 1997; 63 FR 66668, Dec. 2, 1998]

§ 312.30 Protocol amendments.

Once an IND is in effect, a sponsor shall amend it as needed to ensure that the clinical investigations are conducted according to protocols included in the application. This section sets forth the provisions under which new protocols may be submitted and changes in previously submitted protocols may be made. Whenever a sponsor intends to conduct a clinical investigation with an exception from informed consent for emergency research as set forth in § 50.24 of this chapter, the sponsor shall submit a separate IND for such investigation.

(a) *New protocol.* Whenever a sponsor intends to conduct a study that is not covered by a protocol already contained in the IND, the sponsor shall submit to FDA a protocol amendment containing the protocol for the study. Such study may begin provided two conditions are met: (1) The sponsor has submitted the protocol to FDA for its review; and (2) the protocol has been approved by the Institutional Review Board (IRB) with responsibility for review and approval of the study in accordance with the requirements of part 56. The sponsor may comply with these two conditions in either order.

(b) *Changes in a protocol.* (1) A sponsor shall submit a protocol amendment describing any change in a Phase 1 protocol that significantly affects the safety of subjects or any change in a Phase 2 or 3 protocol that significantly affects the safety of subjects, the scope of the investigation, or the scientific quality of the study. Examples of changes requiring an amendment under this paragraph include:

(i) Any increase in drug dosage or duration of exposure of individual subjects to the drug beyond that in the current protocol, or any significant increase in the number of subjects under study.

(ii) Any significant change in the design of a protocol (such as the addition or dropping of a control group).

(iii) The addition of a new test or procedure that is intended to improve monitoring for, or reduce the risk of, a side effect or adverse event; or the dropping of a test intended to monitor safety.

(2)(i) A protocol change under paragraph (b)(1) of this section may be made provided two conditions are met:

(a) The sponsor has submitted the change to FDA for its review; and

(b) The change has been approved by the IRB with responsibility for review and approval of the study. The sponsor may comply with these two conditions in either order.

(ii) Notwithstanding paragraph (b)(2)(i) of this section, a protocol change intended to eliminate an apparent immediate hazard to subjects may be implemented immediately provided FDA is subsequently notified by protocol amendment and the reviewing

IRB is notified in accordance with § 56.104(c).

(c) *New investigator.* A sponsor shall submit a protocol amendment when a new investigator is added to carry out a previously submitted protocol, except that a protocol amendment is not required when a licensed practitioner is added in the case of a treatment protocol under § 312.34. Once the investigator is added to the study, the investigational drug may be shipped to the investigator and the investigator may begin participating in the study. The sponsor shall notify FDA of the new investigator within 30 days of the investigator being added.

(d) *Content and format.* A protocol amendment is required to be prominently identified as such (i.e., "Protocol Amendment: New Protocol", "Protocol Amendment: Change in Protocol", or "Protocol Amendment: New Investigator"), and to contain the following:

(i) In the case of a new protocol, a copy of the new protocol and a brief description of the most clinically significant differences between it and previous protocols.

(ii) In the case of a change in protocol, a brief description of the change and reference (date and number) to the submission that contained the protocol.

(iii) In the case of a new investigator, the investigator's name, the qualifications to conduct the investigation, reference to the previously submitted protocol, and all additional information about the investigator's study as is required under § 312.23(a)(6)(iii)(b).

(2) Reference, if necessary, to specific technical information in the IND or in a concurrently submitted information amendment to the IND that the sponsor relies on to support any clinically significant change in the new or amended protocol. If the reference is made to supporting information already in the IND, the sponsor shall identify by name, reference number, volume, and page number the location of the information.

(3) If the sponsor desires FDA to comment on the submission, a request for such comment and the specific questions FDA's response should address.

(e) *When submitted.* A sponsor shall submit a protocol amendment for a new protocol or a change in protocol before its implementation. Protocol amendments to add a new investigator or to provide additional information about investigators may be grouped and submitted at 30-day intervals. When several submissions of new protocols or protocol changes are anticipated during a short period, the sponsor is encouraged, to the extent feasible, to include these all in a single submission.

(Collection of information requirements approved by the Office of Management and Budget under control number 0910-0014)

(52 FR 8631, Mar. 19, 1987, as amended at 52 FR 23031, June 17, 1987; 53 FR 1918, Jan. 25, 1988; 61 FR 51530, Oct. 2, 1996)

§312.31 Information amendments.

(a) *Requirement for information amendment.* A sponsor shall report in an information amendment essential information on the IND that is not within the scope of a protocol amendment, IND safety reports, or annual report. Examples of information requiring an information amendment include:

- (1) New toxicology, chemistry, or other technical information; or
- (2) A report regarding the discontinuance of a clinical investigation.

(b) *Content and format of an information amendment.* An information amendment is required to bear prominent identification of its contents (e.g., "Information Amendment: Chemistry, Manufacturing, and Control", "Information Amendment: Pharmacology-Toxicology", "Information Amendment: Clinical"), and to contain the following:

- (1) A statement of the nature and purpose of the amendment.

(2) An organized submission of the data in a format appropriate for scientific review.

(3) If the sponsor desires FDA to comment on an information amendment, a request for such comment.

(c) *When submitted.* Information amendments to the IND should be sub-

mitted as necessary but, to the extent feasible, not more than every 30 days.

(Collection of information requirements approved by the Office of Management and Budget under control number 0910-0014)

(52 FR 8631, Mar. 19, 1987, as amended at 52 FR 23031, June 17, 1987; 53 FR 1918, Jan. 25, 1988)

§312.32 IND safety reports.

(a) *Definitions.* The following definitions of terms apply to this section:

Associated with the use of the drug. There is a reasonable possibility that the experience may have been caused by the drug.

Disability. A substantial disruption of a person's ability to conduct normal life functions.

Life-threatening adverse drug experience. Any adverse drug experience that places the patient or subject, in the view of the investigator, at immediate risk of death from the reaction as it occurred, i.e., it does not include a reaction that, had it occurred in a more severe form, might have caused death.

Serious adverse drug experience. Any adverse drug experience occurring at any dose that results in any of the following outcomes: Death, a life-threatening adverse drug experience, inpatient hospitalization or prolongation of existing hospitalization, a persistent or significant disability/incapacity, or a congenital anomaly/birth defect. Important medical events that may not result in death, be life-threatening, or require hospitalization may be considered a serious adverse drug experience when, based upon appropriate medical judgment, they may jeopardize the patient or subject and may require medical or surgical intervention to prevent one of the outcomes listed in this definition. Examples of such medical events include allergic bronchospasm requiring intensive treatment in an emergency room or at home, blood dyscrasias or convulsions that do not result in inpatient hospitalization, or the development of drug dependency or drug abuse.

Unexpected adverse drug experience. Any adverse drug experience, the specificity or severity of which is not consistent with the current investigator

brochure; or, if an investigator brochure is not required or available, the specificity or severity of which is not consistent with the risk information described in the general investigational plan or elsewhere in the current application, as amended. For example, under this definition, hepatic necrosis would be unexpected (by virtue of greater severity) if the investigator brochure only referred to elevated hepatic enzymes or hepatitis. Similarly, cerebral thromboembolism and cerebral vasculitis would be unexpected (by virtue of greater specificity) if the investigator brochure only listed cerebral vascular accidents. "Unexpected," as used in this definition, refers to an adverse drug experience that has not been previously observed (e.g., included in the investigator brochure) rather than from the perspective of such experience not being anticipated from the pharmacological properties of the pharmaceutical product.

(b) *Review of safety information.* The sponsor shall promptly review all information relevant to the safety of the drug obtained or otherwise received by the sponsor from any source, foreign or domestic, including information derived from any clinical or epidemiological investigations, animal investigations, commercial marketing experience, reports in the scientific literature, and unpublished scientific papers, as well as reports from foreign regulatory authorities that have not already been previously reported to the agency by the sponsor.

(c) *IND safety reports.* (1) *Written reports.*—(i) The sponsor shall notify FDA and all participating investigators in a written IND safety report of:

(A) Any adverse experience associated with the use of the drug that is both serious and unexpected; or

(B) Any finding from tests in laboratory animals that suggests a significant risk for human subjects including reports of mutagenicity, teratogenicity, or carcinogenicity. Each notification shall be made as soon as possible and in no event later than 15 calendar days after the sponsor's initial receipt of the information. Each written notification may be submitted on FDA Form 3500A or in a narrative format (foreign events may be sub-

mitted either on an FDA Form 3500A or, if preferred, on a CIOMS I form; reports from animal or epidemiological studies shall be submitted in a narrative format) and shall bear prominent identification of its contents, i.e., "IND Safety Report." Each written notification to FDA shall be transmitted to the FDA new drug review division in the Center for Drug Evaluation and Research or the product review division in the Center for Biologics Evaluation and Research that has responsibility for review of the IND. If FDA determines that additional data are needed, the agency may require further data to be submitted.

(ii) In each written IND safety report, the sponsor shall identify all safety reports previously filed with the IND concerning a similar adverse experience, and shall analyze the significance of the adverse experience in light of the previous, similar reports.

(2) *Telephone and facsimile transmission safety reports.* The sponsor shall also notify FDA by telephone or by facsimile transmission of any unexpected fatal or life-threatening experience associated with the use of the drug as soon as possible but in no event later than 7 calendar days after the sponsor's initial receipt of the information. Each telephone call or facsimile transmission to FDA shall be transmitted to the FDA new drug review division in the Center for Drug Evaluation and Research or the product review division in the Center for Biologics Evaluation and Research that has responsibility for review of the IND.

(3) *Reporting format or frequency.* FDA may request a sponsor to submit IND safety reports in a format or at a frequency different than that required under this paragraph. The sponsor may also propose and adopt a different reporting format or frequency if the change is agreed to in advance by the director of the new drug review division in the Center for Drug Evaluation and Research or the director of the products review division in the Center for Biologics Evaluation and Research which is responsible for review of the IND.

(4) A sponsor of a clinical study of a marketed drug is not required to make

a safety report for any adverse experience associated with use of the drug that is not from the clinical study itself.

(d) *Followup.* (1) The sponsor shall promptly investigate all safety information received by it.

(2) Followup information to a safety report shall be submitted as soon as the relevant information is available.

(3) If the results of a sponsor's investigation show that an adverse drug experience not initially determined to be reportable under paragraph (c) of this section is so reportable, the sponsor shall report such experience in a written safety report as soon as possible, but in no event later than 15 calendar days after the determination is made.

(4) Results of a sponsor's investigation of other safety information shall be submitted, as appropriate, in an information amendment or annual report.

(e) *Disclaimer.* A safety report or other information submitted by a sponsor under this part (and any release by FDA of that report or information) does not necessarily reflect a conclusion by the sponsor or FDA that the report or information constitutes an admission that the drug caused or contributed to an adverse experience. A sponsor need not admit, and may deny, that the report or information submitted by the sponsor constitutes an admission that the drug caused or contributed to an adverse experience.

(Collection of information requirements approved by the Office of Management and Budget under control number 0910-0014)

(52 FR 8831, Mar. 19, 1987, as amended at 52 FR 23031, June 17, 1987; 55 FR 11579, Mar. 29, 1990; 62 FR 52250, Oct. 7, 1997)

§312.33 Annual reports.

A sponsor shall within 60 days of the anniversary date that the IND went into effect, submit a brief report of the progress of the investigation that includes:

(a) *Individual study information.* A brief summary of the status of each study in progress and each study completed during the previous year. The summary is required to include the following information for each study:

(1) The title of the study (with any appropriate study identifiers such as

protocol number), its purpose, a brief statement identifying the patient population, and a statement as to whether the study is completed.

(2) The total number of subjects initially planned for inclusion in the study; the number entered into the study to date, tabulated by age group, gender, and race; the number whose participation in the study was completed as planned; and the number who dropped out of the study for any reason.

(3) If the study has been completed, or if interim results are known, a brief description of any available study results.

(b) *Summary information.* Information obtained during the previous year's clinical and nonclinical investigations, including:

(1) A narrative or tabular summary showing the most frequent and most serious adverse experiences by body system.

(2) A summary of all IND safety reports submitted during the past year.

(3) A list of subjects who died during participation in the investigation, with the cause of death for each subject.

(4) A list of subjects who dropped out during the course of the investigation in association with any adverse experience, whether or not thought to be drug related.

(5) A brief description of what, if anything, was obtained that is pertinent to an understanding of the drug's actions, including, for example, information about dose response, information from controlled trials, and information about bioavailability.

(6) A list of the preclinical studies (including animal studies) completed or in progress during the past year and a summary of the major preclinical findings.

(7) A summary of any significant manufacturing or microbiological changes made during the past year.

(c) A description of the general investigational plan for the coming year to replace that submitted 1 year earlier. The general investigational plan shall contain the information required under §312.23(a)(3)(iv).

(d) If the investigator brochure has been revised, a description of the revision and a copy of the new brochure.

(e) A description of any significant Phase 1 protocol modifications made during the previous year and not previously reported to the IND in a protocol amendment.

(f) A brief summary of significant foreign marketing developments with the drug during the past year, such as approval of marketing in any country or withdrawal or suspension from marketing in any country.

(g) If desired by the sponsor, a log of any outstanding business with respect to the IND for which the sponsor requests or expects a reply, comment, or meeting.

(Collection of information requirements approved by the Office of Management and Budget under control number 0910-0014)

(52 FR 8831, Mar. 19, 1987, as amended at 52 FR 23031, June 17, 1987; 63 FR 6862, Feb. 11, 1998)

§312.34 Treatment use of an investigational new drug.

(a) *General.* A drug that is not approved for marketing may be under clinical investigation for a serious or immediately life-threatening disease condition in patients for whom no comparable or satisfactory alternative drug or other therapy is available. During the clinical investigation of the drug, it may be appropriate to use the drug in the treatment of patients not in the clinical trials, in accordance with a treatment protocol or treatment IND. The purpose of this section is to facilitate the availability of promising new drugs to desperately ill patients as early in the drug development process as possible, before general marketing begins, and to obtain additional data on the drug's safety and effectiveness. In the case of a serious disease, a drug ordinarily may be made available for treatment use under this section during Phase 3 investigations or after all clinical trials have been completed; however, in appropriate circumstances, a drug may be made available for treatment use during Phase 2. In the case of an immediately life-threatening disease, a drug may be made available for treatment use under this section earlier than Phase 3, but ordinarily not earlier than Phase 2. For purposes of this section, the "treatment use" of a drug includes

the use of a drug for diagnostic purposes. If a protocol for an investigational drug meets the criteria of this section, the protocol is to be submitted as a treatment protocol under the provisions of this section.

(b) *Criteria.* (1) FDA shall permit an investigational drug to be used for a treatment use under a treatment protocol or treatment IND if:

(i) The drug is intended to treat a serious or immediately life-threatening disease;

(ii) There is no comparable or satisfactory alternative drug or other therapy available to treat that stage of the disease in the intended patient population;

(iii) The drug is under investigation in a controlled clinical trial under an IND in effect for the trial, or all clinical trials have been completed; and

(iv) The sponsor of the controlled clinical trial is actively pursuing marketing approval of the investigational drug with due diligence.

(2) *Serious disease.* For a drug intended to treat a serious disease, the Commissioner may deny a request for treatment use under a treatment protocol or treatment IND if there is insufficient evidence of safety and effectiveness to support such use.

(3) *Immediately life-threatening disease.*

(i) For a drug intended to treat an immediately life-threatening disease, the Commissioner may deny a request for treatment use of an investigational drug under a treatment protocol or treatment IND if the available scientific evidence, taken as a whole, fails to provide a reasonable basis for concluding that the drug:

(A) May be effective for its intended use in its intended patient population; or

(B) Would not expose the patients to whom the drug is to be administered to an unreasonable and significant additional risk of illness or injury.

(ii) For the purpose of this section, an "immediately life-threatening" disease means a stage of a disease in which there is a reasonable likelihood that death will occur within a matter of months or in which premature death is likely without early treatment.

(c) *Safeguards.* Treatment use of an investigational drug is controlled on

the sponsor and investigators complying with the safeguards of the IND process, including the regulations governing informed consent (21 CFR part 312.34) and institutional review boards (21 CFR part 56) and the applicable provisions of part 312, including distribution of the drug through qualified experts, maintenance of adequate manufacturing facilities, and submission of IND safety reports.

(d) *Clinical hold.* FDA may place on clinical hold a proposed or ongoing treatment protocol or treatment IND in accordance with §312.42.

52 FR 19476, May 22, 1987, as amended at 57 FR 13248, Apr. 15, 1992]

§312.35 Submissions for treatment use.

(a) *Treatment protocol submitted by IND sponsor.* Any sponsor of a clinical investigation of a drug who intends to sponsor a treatment use for the drug must submit to FDA a treatment protocol under §312.34 if the sponsor believes the criteria of §312.34 are satisfied. If a protocol is not submitted under §312.34, but FDA believes that the protocol should have been submitted under this section, FDA may require the protocol to be submitted under §312.34. A treatment use under a treatment protocol may begin 30 days after FDA receives the protocol or on earlier notification by FDA that the treatment use described in the protocol may begin.

(1) A treatment protocol is required to contain the following:

- i) The intended use of the drug.
- ii) An explanation of the rationale for use of the drug, including, as appropriate, either a list of what available treatments ordinarily should be tried before using the investigational drug or an explanation of why the use of the investigational drug is preferable to the use of available marketed treatments.
- iii) A brief description of the criteria for patient selection.
- iv) The method of administration of the drug and the dosages.
- v) A description of clinical procedures, laboratory tests, or other measures to monitor the effects of the drug and to minimize risk.

(2) A treatment protocol is to be supported by the following:

(i) Informational brochure for supplying to each treating physician.

(ii) The technical information that is relevant to safety and effectiveness of the drug for the intended treatment purpose. Information contained in the sponsor's IND may be incorporated by reference.

(iii) A commitment by the sponsor to assure compliance of all participating investigators with the informed consent requirements of 21 CFR part 50.

(3) A licensed practitioner who receives an investigational drug for treatment use under a treatment protocol is an "investigator" under the protocol and is responsible for meeting all applicable investigator responsibilities under this part and 21 CFR parts 50 and 56.

(b) *Treatment IND submitted by licensed practitioner.* (1) If a licensed medical practitioner wants to obtain an investigational drug subject to a controlled clinical trial for a treatment use, the practitioner should first attempt to obtain the drug from the sponsor of the controlled trial under a treatment protocol. If the sponsor of the controlled clinical investigation of the drug will not establish a treatment protocol for the drug under paragraph (a) of this section, the licensed medical practitioner may seek to obtain the drug from the sponsor and submit a treatment IND to FDA requesting authorization to use the investigational drug for treatment use. A treatment use under a treatment IND may begin 30 days after FDA receives the IND or on earlier notification by FDA that the treatment use under the IND may begin. A treatment IND is required to contain the following:

(i) A cover sheet (Form FDA 1571) meeting §312.23(g)(1).

(ii) Information (when not provided by the sponsor) on the drug's chemistry, manufacturing, a. . . controls, and prior clinical and nonclinical experience with the drug submitted in accordance with §312.23. A sponsor of a clinical investigation subject to an IND who supplies an investigational drug to a licensed medical practitioner for purposes of a separate treatment clinical investigation shall be deemed to authorize the incorporation-by-reference

of the technical information contained in the sponsor's IND into the medical practitioner's treatment IND.

(iii) A statement of the steps taken by the practitioner to obtain the drug under a treatment protocol from the drug sponsor.

(iv) A treatment protocol containing the same information listed in paragraph (a)(1) of this section.

(v) A statement of the practitioner's qualifications to use the investigational drug for the intended treatment use.

(vi) The practitioner's statement of familiarity with information on the drug's safety and effectiveness derived from previous clinical and nonclinical experience with the drug.

(vii) Agreement to report to FDA safety information in accordance with §312.32.

(2) A licensed practitioner who submits a treatment IND under this section is the sponsor-investigator for such IND and is responsible for meeting all applicable sponsor and investigator responsibilities under this part and 21 CFR parts 50 and 56.

(Collection of information requirements approved by the Office of Management and Budget under control number 0910-0014)

52 FR 19477, May 22, 1987, as amended at 57 FR 13249, Apr. 15, 1992]

§312.36 Emergency use of an investigational new drug.

Need for an investigational drug may arise in an emergency situation that does not allow time for submission of an IND in accordance with §312.23 or §312.34. In such a case, FDA may authorize shipment of the drug for a specified use in advance of submission of an IND. A request for such authorization may be transmitted to FDA by telephone or other rapid communication means. For investigational biological drugs, the request should be directed to the Division of Biological Investigational New Drugs (HFB-230), Center for Biologics Evaluation and Research, 8800 Rockville Pike, Bethesda, MD 20892, 301-443-4864. For all other investigational drugs, the request for authorization should be directed to the Document Management and Reporting Branch (HFD-53), Center for Drug Evaluation and Research, 5600 Fishers Lane,

Rockville, MD 20857, 301-443-4320. After normal working hours, eastern standard time, the request should be directed to the FDA Division of Emergency and Epidemiological Operations, 202-857-8400. Except in extraordinary circumstances, such authorization will be conditioned on the sponsor making an appropriate IND submission as soon as practicable after receiving the authorization.

(Collection of information requirements approved by the Office of Management and Budget under control number 0910-0014)

52 FR 8831, Mar. 19, 1987, as amended at 52 FR 23031, June 17, 1987; 55 FR 11579, Mar. 29, 1990]

§312.38 Withdrawal of an IND.

(a) At any time a sponsor may withdraw an effective IND without prejudice.

(b) If an IND is withdrawn, FDA shall be so notified, all clinical investigations conducted under the IND shall be ended, all current investigators notified, and all stocks of the drug returned to the sponsor or otherwise disposed of at the request of the sponsor in accordance with §312.59.

(c) If an IND is withdrawn because of a safety reason, the sponsor shall promptly so inform FDA, all participating investigators, and all reviewing Institutional Review Boards, together with the reasons for such withdrawal.

(Collection of information requirements approved by the Office of Management and Budget under control number 0910-0014)

52 FR 8831, Mar. 19, 1987, as amended at 52 FR 23031, June 17, 1987]

Subpart C—Administrative Actions

§312.40 General requirements for use of an investigational new drug in a clinical investigation.

(a) An investigational new drug may be used in a clinical investigation if the following conditions are met:

(1) The sponsor of the investigation submits an IND for the drug to FDA; the IND is in effect under paragraph (b) of this section; and the sponsor complies with all applicable requirements in this part and parts 50 and 56 with respect to the conduct of the clinical investigations; and

(2) Each participating investigator conducts his or her investigation in compliance with the requirements of this part and parts 50 and 56.

(b) An IND goes into effect:

(1) Thirty days after FDA receives the IND, unless FDA notifies the sponsor that the investigations described in the IND are subject to a clinical hold under §312.42; or

(2) On earlier notification by FDA that the clinical investigations in the IND may begin. FDA will notify the sponsor in writing of the date it receives the IND.

(c) A sponsor may ship an investigational new drug to investigators named in the IND:

(1) Thirty days after FDA receives the IND; or

(2) On earlier FDA authorization to ship the drug.

(d) An investigator may not administer an investigational new drug to human subjects until the IND goes into effect under paragraph (b) of this section.

§312.41 Comment and advice on an IND.

(a) FDA may at any time during the course of the investigation communicate with the sponsor orally or in writing about deficiencies in the IND or about FDA's need for more data or information.

(b) On the sponsor's request, FDA will provide advice on specific matters relating to an IND. Examples of such advice may include advice on the adequacy of technical data to support an investigational plan, on the design of a clinical trial, and on whether proposed investigations are likely to produce the data and information that is needed to meet requirements for a marketing application.

(c) Unless the communication is accompanied by a clinical hold order under §312.42, FDA communications with a sponsor under this section are solely advisory and do not require any modification in the planned or ongoing

clinical investigations or response to the agency.

(Collection of information requirements approved by the Office of Management and Budget under control number 0910-0014)

(52 FR 8831, Mar. 19, 1987, as amended at 52 FR 23031, June 17, 1987)

§312.42 Clinical holds and requests for modification.

(a) *General.* A clinical hold is an order issued by FDA to the sponsor to delay a proposed clinical investigation or to suspend an ongoing investigation. The clinical hold order may apply to one or more of the investigations covered by an IND. When a proposed study is placed on clinical hold, subjects may not be given the investigational drug. When an ongoing study is placed on clinical hold, no new subjects may be recruited to the study and placed on the investigational drug; patients already in the study should be taken off therapy involving the investigational drug unless specifically permitted by FDA in the interest of patient safety.

(b) *Grounds for imposition of clinical hold—(1) Clinical hold of a Phase 1 study under an IND.* FDA may place a proposed or ongoing Phase 1 investigation on clinical hold if it finds that:

(i) Human subjects are or would be exposed to an unreasonable and significant risk of illness or injury;

(ii) The clinical investigators named in the IND are not qualified by reason of their scientific training and experience to conduct the investigation described in the IND;

(iii) The investigator brochure is misleading, erroneous, or materially incomplete; or

(iv) The IND does not contain sufficient information required under §312.23 to assess the risks to subjects of the proposed studies.

(2) *Clinical hold of a Phase 2 or 3 study under an IND.* FDA may place a proposed or ongoing Phase 2 or 3 investigation on clinical hold if it finds that:

(i) Any of the conditions in paragraph (b)(1)(i) through (iv) of this section apply; or

(ii) The plan or protocol for the investigation is clearly deficient in design to meet its stated objectives.

(3) *Clinical hold of a treatment IND or treatment protocol.*

(i) *Proposed use.* FDA may place a proposed treatment IND or treatment protocol on clinical hold if it is determined that:

(A) The pertinent criteria in §312.34(b) for permitting the treatment use to begin are not satisfied; or

(B) The treatment protocol or treatment IND does not contain the information required under §312.35 (a) or (b) to make the specified determination under §312.34(b).

(ii) *Ongoing use.* FDA may place an ongoing treatment protocol or treatment IND on clinical hold if it is determined that:

(A) There becomes available a comparable or satisfactory alternative drug or other therapy to treat that stage of the disease in the intended patient population for which the investigational drug is being used;

(B) The investigational drug is not under investigation in a controlled clinical trial under an IND in effect for the trial and not all controlled clinical trials necessary to support a marketing application have been completed, or a clinical study under the IND has been placed on clinical hold;

(C) The sponsor of the controlled clinical trial is not pursuing marketing approval with due diligence;

(D) If the treatment IND or treatment protocol is intended for a serious disease, there is insufficient evidence of safety and effectiveness to support such use; or

(E) If the treatment protocol or treatment IND was based on an immediately life-threatening disease, the available scientific evidence, taken as a whole, fails to provide a reasonable basis for concluding that the drug:

(1) May be effective for its intended use in its intended population; or

(2) Would not expose the patients to whom the drug is to be administered to an unreasonable and significant additional risk of illness or injury.

(iii) FDA may place a proposed or ongoing treatment IND or treatment protocol on clinical hold if it finds that any of the conditions in paragraph

(b)(4)(i) through (b)(4)(viii) of this section apply.

(4) *Clinical hold of any study that is not designed to be adequate and well-controlled.* FDA may place a proposed or ongoing investigation that is not designed to be adequate and well-controlled on clinical hold if it finds that:

(i) Any of the conditions in paragraph (b)(1) or (b)(2) of this section apply; or

(ii) There is reasonable evidence the investigation that is not designed to be adequate and well-controlled is impeding enrollment in, or otherwise interfering with the conduct or completion of, a study that is designed to be an adequate and well-controlled investigational drug; or

(iii) Insufficient quantities of the investigational drug exist to adequately conduct both the investigation that is not designed to be adequate and well-controlled and the investigations that are designed to be adequate and well-controlled; or

(iv) The drug has been studied in one or more adequate and well-controlled investigations that strongly suggest lack of effectiveness; or

(v) Another drug under investigation or approved for the same indication and available to the same patient population has demonstrated a better potential benefit/risk balance; or

(vi) The drug has received marketing approval for the same indication in the same patient population; or

(vii) The sponsor of the study that is designed to be an adequate and well-controlled investigation is not actively pursuing marketing approval of the investigational drug with due diligence; or

(viii) The Commissioner determines that it would not be in the public interest for the study to be conducted or continued. FDA ordinarily intends that clinical holds under paragraphs (b)(4)(ii), (b)(4)(iii) and (b)(4)(v) of this section would only apply to additional enrollment in nonconcurrently controlled trials rather than eliminating continued access to individuals already receiving the investigational drug.

(5) *Clinical hold of any investigation involving an exemption from informed consent under §50.24 of this chapter.* FDA

may place a proposed or ongoing investigation involving an exception from informed consent under §50.24 of this chapter on clinical hold if it is determined that:

(1) Any of the conditions in paragraphs (b)(1) or (b)(2) of this section apply; or

(2) The pertinent criteria in §50.24 of this chapter for such an investigation to begin or continue are not submitted or not satisfied.

(c) *Discussion of deficiency.* Whenever FDA concludes that a deficiency exists in a clinical investigation that may be on clinical hold, unless patients are exposed to immediate and serious risk, FDA will, unless patients are exposed to immediate and serious risk, attempt to discuss and satisfactorily resolve the matter with the sponsor before issuing the clinical hold order.

(d) *Imposition of clinical hold.* The clinical hold order may be made by telephone or other means of rapid communication or in writing. The clinical hold order will identify the studies under the IND to which the hold applies, and will briefly explain the basis for the action. The clinical hold order will be made by or on behalf of the Division Director with responsibility for review of the IND. As soon as possible, and no more than 30 days after imposition of the clinical hold, the Division Director will provide the sponsor a written explanation of the basis for the hold.

(e) *Resumption of clinical investigations.* An investigation may only resume after FDA (usually the Division Director, or the Director's designee, with responsibility for review of the IND) has notified the sponsor that the investigation may proceed. Resumption of the affected investigation(s) will be authorized when the sponsor corrects the deficiency(ies) previously cited or otherwise satisfies the agency that the investigation(s) can proceed. FDA may notify a sponsor of its determination regarding the clinical hold by telephone or other means of rapid communication. If a sponsor of an IND that has been placed on clinical hold requests in writing that the clinical hold be removed and submits a complete response to the issue(s) identified in the clinical hold order, FDA shall respond in writing to the sponsor within 30-cal-

endar days of receipt of the request for the complete response. FDA's response will either remove or maintain the clinical hold, and will state the reasons for such determination. Notwithstanding the 30-calendar day response time, a sponsor may not proceed with a clinical trial on which a clinical hold has been imposed until the sponsor has been notified by FDA that the hold has been lifted.

(f) *Appeal.* If the sponsor disagrees with the reasons cited for the clinical hold, the sponsor may request reconsideration of the decision in accordance with §312.48.

(g) *Conversion of IND on clinical hold to inactive status.* If all investigations covered by an IND remain on clinical hold for 1 year or more, the IND may be placed on inactive status by FDA under §312.45.

(52 FR 8831, Mar. 19, 1987, as amended at 52 FR 19477, May 22, 1987; 57 FR 13249, Apr. 15, 1992; 61 FR 51530, Oct. 2, 1996; 63 FR 68678, Dec. 14, 1998)

EFFECTIVE DATE NOTE: At 63 FR 68678, Dec. 14, 1998, §312.42 was amended by revising paragraph (e), effective Apr. 28, 1999. For the convenience of the user, the superseded text follows:

§312.42 Clinical holds and requests for modification.

(e) *Resumption of clinical investigations.* If, by the terms of the clinical hold order, resumption of the affected investigation is permitted without prior notification by FDA once a stated correction or modification is made, the investigation may proceed as soon as the correction or modification is made. In all other cases, an investigation may only resume after the Division Director (or the Director's designee) with responsibility for review of the IND has notified the sponsor that the investigation may proceed. In these cases resumption of the affected investigation(s) will be authorized when the sponsor corrects the deficiency(ies) previously cited or otherwise satisfied the agency that the investigation(s) can proceed. Resumption of a study may be authorized by telephone or other means of rapid communication.

§312.44 Termination.

(a) *General.* This section describes the procedures under which FDA may terminate an IND. If an IND is terminated, the sponsor shall end all clinical investigations conducted under the IND and recall or otherwise provide for the disposition of all unused supplies of the drug. A termination action may be based on deficiencies in the IND or in the conduct of an investigation under an IND. Except as provided in paragraph (d) of this section, a termination shall be preceded by a proposal to terminate by FDA and an opportunity for the sponsor to respond. FDA will, in general, only initiate an action under this section after first attempting to resolve differences informally or, when appropriate, through the clinical hold procedures described in §312.42.

(b) *Grounds for termination—(1) Phase 1.* FDA may propose to terminate an IND during Phase 1 if it finds that:

(i) Human subjects would be exposed to an unreasonable and significant risk of illness or injury.

(ii) The IND does not contain sufficient information required under §312.23 to assess the safety to subjects of the clinical investigations.

(iii) The methods, facilities, and controls used for the manufacturing, processing, and packing of the investigational drug are inadequate to establish and maintain appropriate standards of identity, strength, quality, and purity as needed for subject safety.

(iv) The clinical investigations are being conducted in a manner substantially different than that described in the protocols submitted in the IND.

(v) The drug is being promoted or distributed for commercial purposes not justified by the requirements of the investigation or permitted by §312.7.

(vi) The IND, or any amendment or report to the IND, contains an untrue statement of a material fact or omits material information required by this part.

(vii) The sponsor fails promptly to investigate and inform the Food and Drug Administration and all investigators of serious and unexpected adverse experiences in accordance with §312.33 or fails to make any other report required under this part.

(viii) The sponsor fails to submit an accurate annual report of the investigations in accordance with §312.33.

(ix) The sponsor fails to comply with any other applicable requirement of this part, part 50, or part 58.

(x) The IND has remained on inactive status for 5 years or more.

(xi) The sponsor fails to delay a proposed investigation under the IND or to suspend an ongoing investigation that has been placed on clinical hold under §312.42(b)(4).

(2) *Phase 2 or 3.* FDA may propose to terminate an IND during Phase 2 or Phase 3 if FDA finds that:

(i) Any of the conditions in paragraphs (b)(1)(i) through (b)(1)(xi) of this section apply; or

(ii) The investigational plan or protocol(s) is not reasonable as a bona fide scientific plan to determine whether or not the drug is safe and effective for use; or

(iii) There is convincing evidence that the drug is not effective for the purpose for which it is being investigated.

(3) FDA may propose to terminate a treatment IND if it finds that:

(i) Any of the conditions in paragraphs (b)(1)(i) through (x) of this section apply; or

(ii) Any of the conditions in §312.42(b)(3) apply.

(c) *Opportunity for sponsor response.*

(1) If FDA proposes to terminate an IND, FDA will notify the sponsor in writing, and invite correction or explanation within a period of 30 days.

(2) On such notification, the sponsor may provide a written explanation or correction or may request a conference with FDA to provide the requested explanation or correction. If the sponsor does not respond to the notification within the allocated time, the IND shall be terminated.

(3) If the sponsor responds but FDA does not accept the explanation or correction submitted, FDA shall inform the sponsor in writing of the reason for the nonacceptance and provide the sponsor with an opportunity for a regulatory hearing before FDA under part 16 on the question of whether the IND should be terminated. The sponsor's request for a regulatory hearing must be made within 10 days of the sponsor's

receipt of FDA's notification of non-acceptance.

(d) *Immediate termination of IND.* Notwithstanding paragraphs (a) through (c) of this section, if at any time FDA concludes that continuation of the investigation presents an immediate and substantial danger to the health of individuals, the agency shall immediately, by written notice to the sponsor from the Director of the Center for Drug Evaluation and Research or the Director of the Center for Biologics Evaluation and Research, terminate the IND. An IND so terminated is subject to reinstatement by the Director on the basis of additional submissions that eliminate such danger. If an IND is terminated under this paragraph, the agency will afford the sponsor an opportunity for a regulatory hearing under part 16 on the question of whether the IND should be reinstated.

(Collection of information requirements approved by the Office of Management and Budget under control number 0910-0014)

[52 FR 8831, Mar. 19, 1987, as amended at 52 FR 23031, June 17, 1987; 55 FR 11579, Mar. 29, 1990; 57 FR 13249, Apr. 15, 1992]

§312.45 Inactive status.

(a) If no subjects are entered into clinical studies for a period of 2 years or more under an IND, or if all investigations under an IND remain on clinical hold for 1 year or more, the IND may be placed by FDA on inactive status. This action may be taken by FDA either on request of the sponsor or on FDA's own initiative. If FDA seeks to act on its own initiative under this section, it shall first notify the sponsor in writing of the proposed inactive status. Upon receipt of such notification, the sponsor shall have 30 days to respond as to why the IND should continue to remain active.

(b) If an IND is placed on inactive status, all investigators shall be so notified and all stocks of the drug shall be returned or otherwise disposed of in accordance with §312.59.

(c) A sponsor is not required to submit annual reports to an IND on inactive status. An inactive IND is, however, still in effect for purposes of the public disclosure of data and information under §312.136.

(d) A sponsor who intends to resume clinical investigation under an IND placed on inactive status shall submit a protocol amendment under §312.30 containing the proposed general investigational plan for the coming year and appropriate protocols. If the protocol amendment relies on information previously submitted, the plan shall reference such information. Additional information supporting the proposed investigation, if any, shall be submitted in an information amendment. Notwithstanding the provisions of §312.30, clinical investigations under an IND on inactive status may only resume (1) 30 days after FDA receives the protocol amendment, unless FDA notifies the sponsor that the investigations described in the amendment are subject to a clinical hold under §312.42, or (2) on earlier notification by FDA that the clinical investigations described in the protocol amendment may begin.

(e) An IND that remains on inactive status for 5 years or more may be terminated under §312.44.

(Collection of information requirements approved by the Office of Management and Budget under control number 0910-0014)

[52 FR 8831, Mar. 19, 1987, as amended at 52 FR 23031, June 17, 1987]

§312.47 Meetings.

(a) *General.* Meetings between a sponsor and the agency are frequently useful in resolving questions and issues raised during the course of a clinical investigation. FDA encourages such meetings to the extent that they aid in the evaluation of the drug and in the solution of scientific problems concerning the drug, to the extent that FDA's resources permit. The general principle underlying the conduct of such meetings is that there should be free, full, and open communication about any scientific or medical question that may arise during the clinical investigation. These meetings shall be conducted and documented in accordance with part 10.

(b) *"End-of-Phase 2" meetings and meetings held before submission of a marketing application.* At specific times during the drug investigation process, meetings between FDA and a sponsor can be especially helpful in minimizing wasteful expenditures of time and

money and thus in speeding the drug development and evaluation process. In particular, FDA has found that meetings at the end of Phase 2 of an investigation (end-of-Phase 2 meetings) are of considerable assistance in planning later studies and that meetings held near completion of Phase 3 and before submission of a marketing application ("pre-NDA" meetings) are helpful in developing methods of presentation and submission of data in the marketing application that facilitate review and allow timely FDA response.

(1) *End-of-Phase 2 meetings—(i) Purpose.* The purpose of an end-of-phase 2 meeting is to determine the safety of proceeding to Phase 3, to evaluate the Phase 3 plan and protocols and the adequacy of current studies and plans to assess pediatric safety and effectiveness, and to identify any additional information necessary to support a marketing application for the uses under investigation.

(ii) *Eligibility for meeting.* While the end-of-Phase 2 meeting is designed primarily for IND's involving new molecular entities or major new uses of marketed drugs, a sponsor of any IND may request and obtain an end-of-Phase 2 meeting.

(iii) *Timing.* To be most useful to the sponsor, end-of-Phase 2 meetings should be held before major commitments of effort and resources to specific Phase 3 tests are made. The scheduling of an end-of-Phase 2 meeting is not, however, intended to delay the transition of an investigation from Phase 2 to Phase 3.

(iv) *Advance information.* At least 1 month in advance of an end-of-Phase 2 meeting, the sponsor should submit background information on the sponsor's plan for Phase 3, including summaries of the Phase 1 and 2 investigations, the specific protocols for Phase 3 clinical studies, plans for any additional nonclinical studies, plans for pediatric studies, including a time line for protocol finalization, enrollment, completion, and data analysis, or information to support any planned request for waiver or deferral of pediatric studies, and, if available, tentative labeling for the drug. The recommended contents of such a submission are described more fully in FDA Staff Man-

ual Guide 4850.7 that is publicly available under FDA's public information regulations in part 20.

(v) *Conduct of meeting.* Arrangements for an end-of-Phase 2 meeting are to be made with the division in FDA's Center for Drug Evaluation and Research or the Center for Biologics Evaluation and Research which is responsible for review of the IND. The meeting will be scheduled by FDA at a time convenient to both FDA and the sponsor. Both the sponsor and FDA may bring consultants to the meeting. The meeting should be directed primarily at establishing agreement between FDA and the sponsor of the overall plan for Phase 3 and the objectives and design of particular studies. The adequacy of the technical information to support Phase 3 studies and/or a marketing application may also be discussed. FDA will also provide its best judgment, at that time, of the pediatric studies that will be required for the drug product and whether their submission will be deferred until after approval. Agreements reached at the meeting on these matters will be recorded in minutes of the conference that will be taken by FDA in accordance with §10.65 and provided to the sponsor. The minutes along with any other written material provided to the sponsor will serve as a permanent record of any agreements reached. Barring a significant scientific development that requires otherwise, studies conducted in accordance with the agreement shall be presumed to be sufficient in objective and design for the purpose of obtaining marketing approval for the drug.

(2) *"Pre-NDA" and "pre-BLA" meetings.* FDA has found that delays associated with the initial review of a marketing application may be reduced by exchanges of information about a proposed marketing application. The primary purpose of this kind of exchange is to uncover any major unresolved problems, to identify those studies that the sponsor is relying on as adequate and well-controlled to establish the drug's effectiveness, to identify the status of ongoing or needed studies adequate to assess pediatric safety and effectiveness, to acquaint FDA reviewers with the general information to be

submitted in the marketing application (including technical information), to discuss appropriate methods for statistical analysis of the data, and to discuss the best approach to the presentation and formatting of data in the marketing application. Arrangements for such a meeting are to be initiated by the sponsor with the division responsible for review of the IND. To permit FDA to provide the sponsor with the most useful advice on preparing a marketing application, the sponsor should submit to FDA's reviewing division at least 1 month in advance of the meeting the following information:

- (i) A brief summary of the clinical studies to be submitted in the application.
- (ii) A proposed format for organizing the submission, including methods for presenting the data.
- (iii) Information on the status of needed or ongoing pediatric studies.
- (iv) Any other information for discussion at the meeting.

(Collection of information requirements approved by the Office of Management and Budget under control number 0910-0014)

[52 FR 8831, Mar. 19, 1987, as amended at 52 FR 23031, Jun. 17, 1987; 55 FR 11580, Mar. 29, 1990; 63 FR 66669, Dec. 2, 1998]

§312.48 Dispute resolution.

(a) *General.* The Food and Drug Administration is committed to resolving differences between sponsors and FDA reviewing divisions with respect to requirements for IND's as quickly and amicably as possible through the cooperative exchange of information and views.

(b) *Administrative and procedural issues.* When administrative or procedural disputes arise, the sponsor should first attempt to resolve the matter with the division in FDA's Center for Drug Evaluation and Research or Center for Biologics Evaluation and Research which is responsible for review of the IND, beginning with the consumer safety officer assigned to the application. If the dispute is not resolved, the sponsor may raise the matter with the person designated as ombudsman, whose function shall be to investigate what has happened and to facilitate a timely and equitable resolution. Appropriate issues raised with the ombuds-

man include resolving difficulties in scheduling meetings and obtaining timely replies to inquiries. Further details on this procedure are contained in FDA Staff Manual Guide 4820.7 that is publicly available under FDA's public information regulations in part 20.

(c) *Scientific and medical disputes.* (1) When scientific or medical disputes arise during the drug investigation process, sponsors should discuss the matter directly with the responsible reviewing officials. If necessary, sponsors may request a meeting with the appropriate reviewing officials and management representatives in order to seek a resolution. Requests for such meetings shall be directed to the director of the division in FDA's Center for Drug Evaluation and Research or Center for Biologics Evaluation and Research which is responsible for review of the IND. FDA will make every attempt to grant requests for meetings that involve important issues and that can be scheduled at mutually convenient times.

(2) The "end-of-Phase 2" and "pre-NDA" meetings described in §312.47(b) will also provide a timely forum for discussing and resolving scientific and medical issues on which the sponsor disagrees with the agency.

(3) In requesting a meeting designed to resolve a scientific or medical dispute, applicants may suggest that FDA seek the advice of outside experts, in which case FDA may, in its discretion, invite to the meeting one or more of its advisory committee members or other consultants, as designated by the agency. Applicants may rely on, and may bring to any meeting, their own consultants. For major scientific and medical policy issues not resolved by informal meetings, FDA may refer the matter to one of its standing advisory committees for its consideration and recommendations.

[52 FR 8831, Mar. 19, 1987, as amended at 55 FR 11580, Mar. 29, 1990]

Subpart D—Responsibilities of Sponsors and Investigators

§312.50 General responsibilities of sponsors.

Sponsors are responsible for selecting qualified investigators, providing

them with the information they need to conduct an investigation properly, ensuring proper monitoring of the investigation(s), ensuring that the investigation(s) is conducted in accordance with the general investigational plan and protocols contained in the IND, maintaining an effective IND with respect to the investigations, and ensuring that FDA and all participating investigators are promptly informed of significant new adverse effects or risks with respect to the drug. Additional specific responsibilities of sponsors are described elsewhere in this part.

§312.52 Transfer of obligations to a contract research organization.

(a) A sponsor may transfer responsibility for any or all of the obligations set forth in this part to a contract research organization. Any such transfer shall be described in writing. Not all obligations are transferred; the writing is required to describe each of the obligations being assumed by the contract research organization. If all obligations are transferred, a general statement that all obligations have been transferred is acceptable. Any obligation not covered by the written description shall be deemed not to have been transferred.

(b) A contract research organization that assumes any obligation of a sponsor shall comply with the specific regulations in this chapter applicable to this obligation and shall be subject to the same regulatory action as a sponsor for failure to comply with any obligation assumed under these regulations. Thus, all references to "sponsor" in this part apply to a contract research organization to the extent that it assumes one or more obligations of the sponsor.

§312.53 Selecting investigators and monitors.

(a) *Selecting investigators.* A sponsor shall select only investigators qualified by training and experience as appropriate experts to investigate the drug.

(b) *Control of drug.* A sponsor shall ship investigational new drugs only to investigators participating in the investigation.

(c) *Obtaining information from the investigator.* Before permitting an investi-

gator to begin participation in an investigation, the sponsor shall obtain the following:

(1) A signed investigator statement (Form FDA-1572) containing:

(i) The name and address of the investigator;

(ii) The name and code number, if any, of the protocol(s) in the IND identifying the study(ies) to be conducted by the investigator;

(iii) The name and address of any medical school, hospital, or other research facility where the clinical investigation(s) will be conducted;

(iv) The name and address of any clinical laboratory facilities to be used in the study;

(v) The name and address of the IRB that is responsible for review and approval of the study(ies);

(vi) A commitment by the investigator that he or she:

(a) Will conduct the study(ies) in accordance with the relevant, current protocol(s) and will only make changes in a protocol after notifying the sponsor, except when necessary to protect the safety, the rights, or welfare of subjects;

(b) Will comply with all requirements regarding the obligations of clinical investigators and all other pertinent requirements in this part;

(c) Will personally conduct or supervise the described investigation(s);

(d) Will inform any potential subjects that the drugs are being used for investigational purposes and will ensure that the requirements relating to obtaining informed consent (21 CFR part 50) and institutional review board review and approval (21 CFR part 56) are met;

(e) Will report to the sponsor adverse experiences that occur in the course of the investigation(s) in accordance with §312.64;

(f) Has read and understands the information in the investigator's brochure, including the potential risks and side effects of the drug; and

(g) Will ensure that all associates, colleagues, and employees assisting in the conduct of the study(ies) are informed about their obligations in meeting the above commitments.

(vii) A commitment by the investigator that, for an investigation subject

to an institutional review requirement under part 56, an IRB that complies with the requirements of that part will be responsible for the initial and continuing review and approval of the clinical investigation and that the investigator will promptly report to the IRB all changes in the research activity and all unanticipated problems involving risks to human subjects or others, and will not make any changes in the research without IRB approval, except where necessary to eliminate apparent immediate hazards to the human subjects.

(vii) A list of the names of the sub-investigators (e.g., research fellows, residents) who will be assisting the investigator in the conduct of the investigation(s).

(2) *Curriculum vitae.* A curriculum vitae or other statement of qualifications of the investigator showing the education, training, and experience that qualifies the investigator as an expert in the clinical investigation of the drug for the use under investigation.

(3) *Clinical protocol.* (i) For Phase 1 investigations, a general outline of the planned investigation including the estimated duration of the study and the maximum number of subjects that will be involved.

(ii) For Phase 2 or 3 investigations, an outline of the study protocol including an approximation of the number of subjects to be treated with the drug and the number to be employed as controls, if any; the clinical uses to be investigated; characteristics of subjects by age, sex, and condition; the kind of clinical observations and laboratory tests to be conducted; the estimated duration of the study; and copies or a description of case report forms to be used.

(4) *Financial disclosure information.* Sufficient accurate financial information to allow the sponsor to submit complete and accurate certification or disclosure statements required under part 54 of this chapter. The sponsor shall obtain a commitment from the clinical investigator to promptly update this information if any relevant changes occur during the course of the investigation, and for 1 year following the completion of the study.

(d) *Selecting monitors.* A sponsor shall select a monitor qualified by training and experience to monitor the progress of the investigation.

(Collection of information requirements approved by the Office of Management and Budget under control number 0910-0014)

[52 FR 8831, Mar. 19, 1987, as amended at 52 FR 23031, June 17, 1987; 61 FR 57280, Nov. 5, 1996; 63 FR 5252, Feb. 2, 1998]

§312.54 Emergency research under §50.24 of this chapter.

(a) The sponsor shall monitor the progress of all investigations involving an exception from informed consent under §50.24 of this chapter. When the sponsor receives from the IRB information concerning the public disclosures required by §50.24(a)(7)(ii) and (a)(7)(iii) of this chapter, the sponsor promptly shall submit to the IND file and to Docket Number 95S-0158 in the Dockets Management Branch (HFA-305), Food and Drug Administration, 12420 Parklawn Dr., rm. 1-23, Rockville, MD 20857, copies of the information that was disclosed, identified by the IND number.

(b) The sponsor also shall monitor such investigations to identify when an IRB determines that it cannot approve the research because it does not meet the criteria in the exception in §50.24(a) of this chapter or because of other relevant ethical concerns. The sponsor promptly shall provide this information in writing to FDA, investigators who are asked to participate in this or a substantially equivalent clinical investigation, and other IRB's that are asked to review this or a substantially equivalent investigation.

[61 FR 51530, Oct. 2, 1996]

§312.55 Informing investigators.

(a) Before the investigation begins, a sponsor (other than a sponsor-investigator) shall give each participating clinical investigator an investigator brochure containing the information described in §312.23(a)(5).

(b) The sponsor shall, as the overall investigation proceeds, keep each participating investigator informed of new observations discovered by or reported to the sponsor on the drug, particularly with respect to adverse effects and safe use. Such information may be

distributed to investigators by means of periodically revised investigator brochures, reprints or published studies, reports or letters to clinical investigators, or other appropriate means. Important safety information is required to be relayed to investigators in accordance with §312.32.

(Collection of information requirements approved by the Office of Management and Budget under control number 0910-0014)

[52 FR 8831, Mar. 19, 1987, as amended at 52 FR 23031, June 17, 1987]

§312.56 Review of ongoing investigations.

(a) The sponsor shall monitor the progress of all clinical investigations being conducted under its IND.

(b) A sponsor who discovers that an investigator is not complying with the signed agreement (Form FDA-1572), the general investigational plan, or the requirements of this part or other applicable parts shall promptly either secure compliance or discontinue shipments of the investigational new drug to the investigator and end the investigator's participation in the investigation. If the investigator's participation in the investigation is ended, the sponsor shall require that the investigator dispose of or return the investigational drug in accordance with the requirements of §312.59 and shall notify FDA.

(c) The sponsor shall review and evaluate the evidence relating to the safety and effectiveness of the drug as it is obtained from the investigator. The sponsors shall make such reports to FDA regarding information relevant to the safety of the drug as are required under §312.32. The sponsor shall make annual reports on the progress of the investigation in accordance with §312.33.

(d) A sponsor who determines that its investigational drug presents an unreasonable and significant risk to subjects shall discontinue those investigations that present the risk, notify FDA, all institutional review boards, and all investigators who have at any time participated in the investigation of the discontinuance, assure the disposition of all stocks of the drug outstanding as required by §312.59, and furnish FDA with a full report of the sponsor's actions. The sponsor shall discontinue

the investigation as soon as possible, and in no event later than 5 working days after making the determination that the investigation should be discontinued. Upon request, FDA will confer with a sponsor on the need to discontinue an investigation.

(Collection of information requirements approved by the Office of Management and Budget under control number 0910-0014)

[52 FR 8831, Mar. 19, 1987, as amended at 52 FR 23031, June 17, 1987]

§312.57 Recordkeeping and record retention.

(a) A sponsor shall maintain adequate records showing the receipt, shipment, or other disposition of the investigational drug. These records are required to include, as appropriate, the name of the investigator to whom the drug is shipped, and the date, quantity, and batch or code mark of each such shipment.

(b) A sponsor shall maintain complete and accurate records showing any financial interest in §54.4(a)(3)(i), (a)(3)(ii), (a)(3)(iii), and (a)(3)(iv) of this chapter paid to clinical investigators by the sponsor of the covered study. A sponsor shall also maintain complete and accurate records concerning all other financial interests of investigators subject to part 54 of this chapter.

(c) A sponsor shall retain the records and reports required by this part for 2 years after a marketing application is approved for the drug; or, if an application is not approved for the drug, until 2 years after shipment and delivery of the drug for investigational use is discontinued and FDA has been so notified.

(d) A sponsor shall retain reserve samples of any test article and reference standard identified in, and used in any of the bioequivalence or bioavailability studies described in, §320.38 or §320.63 of this chapter, and release the reserve samples to FDA upon request, in accordance with, and for the period specified in §320.38.

(Collection of information requirements approved by the Office of Management and Budget under control number 0910-0014)

[62 FR 8831, Mar. 19, 1987, as amended at 52 FR 23031, June 17, 1987; 58 FR 25777, Apr. 28, 1993; 63 FR 5252, Feb. 2, 1998]

§312.58 Inspection of sponsor's records and reports.

(a) *FDA inspection.* A sponsor shall upon request from any properly authorized officer or employee of the Food and Drug Administration, at reasonable times, permit such officer or employee to have access to and copy and verify any records and reports relating to a clinical investigation conducted under this part. Upon written request by FDA, the sponsor shall submit the records or reports (or copies of them) to FDA. The sponsor shall discontinue shipments of the drug to any investigator who has failed to maintain or make available records or reports of the investigation as required by this part.

(b) *Controlled substances.* If an investigational new drug is a substance listed in any schedule of the Controlled Substances Act (21 U.S.C. 801; 21 CFR part 1308), records concerning shipment, delivery, receipt, and disposition of the drug, which are required to be kept under this part or other applicable parts of this chapter shall, upon the request of a properly authorized employee of the Drug Enforcement Administration of the U.S. Department of Justice, be made available by the investigator or sponsor to whom the request is made, for inspection and copying. In addition, the sponsor shall assure that adequate precautions are taken, including storage of the investigational drug in a securely locked, substantially constructed cabinet, or other securely locked, substantially constructed enclosure, access to which is limited, to prevent theft or diversion of the substance into illegal channels of distribution.

§312.59 Disposition of unused supply of investigational drug.

The sponsor shall assure the return of all unused supplies of the investigational drug from each individual investigator whose participation in the investigation is discontinued or terminated. The sponsor may authorize alternative disposition of unused supplies of the investigational drug provided this alternative disposition does not expose humans to risks from the drug. The sponsor shall maintain written

records of any disposition of the drug in accordance with §312.57.

(Collection of information requirements approved by the Office of Management and Budget under control number 0910-0014)

[52 FR 8831, Mar. 19, 1987, as amended at 52 FR 23031, June 17, 1987]

§312.60 General responsibilities of investigators.

An investigator is responsible for ensuring that an investigation is conducted according to the signed investigator statement, the investigational plan, and applicable regulations; for protecting the rights, safety, and welfare of subjects under the investigator's care; and for the control of drugs under investigation. An investigator shall, in accordance with the provisions of part 50 of this chapter, obtain the informed consent of each human subject to whom the drug is administered, except as provided in §§50.23 or 50.24 of this chapter. Additional specific responsibilities of clinical investigators are set forth in this part and in parts 50 and 56 of this chapter.

[52 FR 8831, Mar. 19, 1987, as amended at 61 FR 51530, Oct. 2, 1996]

§312.61 Control of the investigational drug.

An investigator shall administer the drug only to subjects under the investigator's personal supervision or under the supervision of a subinvestigator responsible to the investigator. The investigator shall not supply the investigational drug to any person not authorized under this part to receive it.

§312.62 Investigator recordkeeping and record retention.

(a) *Disposition of drug.* An investigator is required to maintain adequate records of the disposition of the drug, including dates, quantity, and use by subjects. If the investigation is terminated, suspended, discontinued, or completed, the investigator shall return the unused supplies of the drug to the sponsor, or otherwise provide for disposition of the unused supplies of the drug under §312.59.

(b) *Case histories.* An investigator is required to prepare and maintain adequate and accurate case histories that

record all observations and other data pertinent to the investigation on each individual administered the investigational drug or employed as a control in the investigation. Case histories include the case report forms and supporting data including, for example, signed and dated consent forms and medical records including, for example, progress notes of the physician, the individual's hospital chart(s), and the nurses' notes. The case history for each individual shall document that informed consent was obtained prior to participation in the study.

(c) *Record retention.* An investigator shall retain records required to be maintained under this part for a period of 2 years following the date a marketing application is approved for the drug for the indication for which it is being investigated; or, if no application is to be filed or if the application is not approved for such indication, until 2 years after the investigation is discontinued and FDA is notified.

(Collection of information requirements approved by the Office of Management and Budget under control number 0910-0014)

[52 FR 8831, Mar. 19, 1987, as amended at 52 FR 23031, June 17, 1987; 61 FR 57280, Nov. 5, 1996]

§312.64 Investigator reports.

(a) *Progress reports.* The investigator shall furnish all reports to the sponsor of the drug who is responsible for collecting and evaluating the results obtained. The sponsor is required under §312.33 to submit annual reports to FDA on the progress of the clinical investigations.

(b) *Safety reports.* An investigator shall promptly report to the sponsor any adverse effect that may reasonably be regarded as caused by, or probably caused by, the drug. If the adverse effect is alarming, the investigator shall report the adverse effect immediately.

(c) *Final report.* An investigator shall provide the sponsor with an adequate report shortly after completion of the investigator's participation in the investigation.

(d) *Financial disclosure reports.* The clinical investigator shall provide the sponsor with sufficient accurate financial information to allow an applicant to submit complete and accurate cer-

tification or disclosure statements as required under part 54 of this chapter. The clinical investigator shall promptly update this information if any relevant changes occur during the course of the investigation and for 1 year following the completion of the study.

(Collection of information requirements approved by the Office of Management and Budget under control number 0910-0014)

[52 FR 8831, Mar. 19, 1987, as amended at 52 FR 23031, June 17, 1987; 63 FR 5252, Feb. 2, 1998]

§312.66 Assurance of IRB review.

An investigator shall assure that an IRB that complies with the requirements set forth in part 56 will be responsible for the initial and continuing review and approval of the proposed clinical study. The investigator shall also assure that he or she will promptly report to the IRB all changes in the research activity and all unanticipated problems involving risk to human subjects or others, and that he or she will not make any changes in the research without IRB approval, except where necessary to eliminate apparent immediate hazards to human subjects.

(Collection of information requirements approved by the Office of Management and Budget under control number 0910-0014)

[52 FR 8831, Mar. 19, 1987, as amended at 52 FR 23031, June 17, 1987]

§312.68 Inspection of investigator's records and reports.

An investigator shall upon request from any properly authorized officer or employee of FDA, at reasonable times, permit such officer or employee to have access to, and copy and verify any records or reports made by the investigator pursuant to §312.62. The investigator is not required to divulge subject names unless the records of particular individuals require a more detailed study of the cases, or unless there is reason to believe that the records do not represent actual case studies, or do not represent actual results obtained.

§312.69 Handling of controlled substances.

If the investigational drug is subject to the Controlled Substances Act, the

Investigator shall take adequate precautions, including storage of the investigational drug in a securely locked, substantially constructed cabinet, or other securely locked, substantially constructed enclosure, access to which is limited, to prevent theft or diversion of the substance into illegal channels of distribution.

§312.70 Disqualification of a clinical investigator.

(a) If FDA has information indicating that an investigator (including a sponsor-investigator) has repeatedly or deliberately failed to comply with the requirements of this part, part 50, or part 56 of this chapter, or has submitted to FDA or to the sponsor false information in any required report, the Center for Drug Evaluation and Research or the Center for Biologics Evaluation and Research will furnish the investigator written notice of the matter complained of and offer the investigator an opportunity to explain the matter in writing, or, at the option of the investigator, in an informal conference. If an explanation is offered but not accepted by the Center for Drug Evaluation and Research or the Center for Biologics Evaluation and Research, the investigator will be given an opportunity for a regulatory hearing under part 16 on the question of whether the investigator is entitled to receive investigational new drugs.

(b) After evaluating all available information, including any explanation presented by the investigator, if the Commissioner determines that the investigator has repeatedly or deliberately failed to comply with the requirements of this part, part 50, or part 56 of this chapter, or has deliberately or repeatedly submitted false information to FDA or to the sponsor in any required report, the Commissioner will notify the investigator and the sponsor of any investigation in which the investigator has been named as a participant that the investigator is not entitled to receive investigational drugs. The notification will provide a statement of basis for such determination.

(c) Each IND and each approved application submitted under part 314 containing data reported by an investigator who has been determined to be

ineligible to receive investigational drugs will be examined to determine whether the investigator has submitted unreliable data that are essential to the continuation of the investigation or essential to the approval of any marketing application.

(d) If the Commissioner determines, after the unreliable data submitted by the investigator are eliminated from consideration, that the data remaining are inadequate to support a conclusion that it is reasonably safe to continue the investigation, the Commissioner will notify the sponsor who shall have an opportunity for a regulatory hearing under part 16. If a danger to the public health exists, however, the Commissioner shall terminate the IND immediately and notify the sponsor of the determination. In such case, the sponsor shall have an opportunity for a regulatory hearing before FDA under part 16 on the question of whether the IND should be reinstated.

(e) If the Commissioner determines, after the unreliable data submitted by the investigator are eliminated from consideration, that the continued approval of the drug product for which the data were submitted cannot be justified, the Commissioner will proceed to withdraw approval of the drug product in accordance with the applicable provisions of the act.

(f) An investigator who has been determined to be ineligible to receive investigational drugs may be reinstated as eligible when the Commissioner determines that the investigator has presented adequate assurances that the investigator will employ investigational drugs solely in compliance with the provisions of this part and of parts 50 and 56.

(Collection of information requirements approved by the Office of Management and Budget under control number 0910-0014)

[52 FR 8831, Mar. 19, 1987, as amended at 52 FR 23031, June 17, 1987; 55 FR 11580, Mar. 29, 1990; 62 FR 49876, Sept. 5, 1997]

Subpart E—Drugs Intended to Treat Life-Threatening and Severely-Debilitating Illnesses

Authority: 21 U.S.C. 351, 352, 353, 355, 371; 42 U.S.C. 262.

Source: 53 FR 41523, Oct. 21, 1988, unless otherwise noted.

§312.80 Purpose.

The purpose of this section is to establish procedures designed to expedite the development, evaluation, and marketing of new therapies intended to treat persons with life-threatening and severely-debilitating illnesses, especially where no satisfactory alternative therapy exists. As stated in §312.105(c) of this chapter, while the statutory standards of safety and effectiveness apply to all drugs, the many kinds of drugs that are subject to them, and the wide range of uses for those drugs, demand flexibility in applying the standards. The Food and Drug Administration (FDA) has determined that it is appropriate to exercise the broadest flexibility in applying the statutory standards, while preserving appropriate guarantees for safety and effectiveness. These procedures reflect the recognition that physicians and patients are generally willing to accept greater risks or side effects from products that treat life-threatening and severely-debilitating illnesses, than they would accept from products that treat less serious illnesses. These procedures also reflect the recognition that the benefits of the drug need to be evaluated in light of the severity of the disease being treated. The procedure outlined in this section should be interpreted consistent with that purpose.

§312.81 Scope.

This section applies to new drug and biological products that are being studied for their safety and effectiveness in treating life-threatening or severely-debilitating diseases.

(a) For purposes of this section, the term "life-threatening" means:

(1) Diseases or conditions where the likelihood of death is high unless the course of the disease is interrupted; and

(2) Diseases or conditions with potentially fatal outcomes, where the end point of clinical trial analysis is survival.

(b) For purposes of this section, the term "severely debilitating" means diseases or conditions that cause major or disabling morbidity.

(c) Sponsors are encouraged to consult with FDA on the applicability of these procedures to specific products.

[53 FR 41523, Oct. 21, 1988, as amended at 64 FR 401, Jan. 5, 1999]

EFFECTIVE DATE NOTE: At 64 FR 401, Jan. 5, 1999, §312.81 was amended by moving "antibiotic" from the introductory text, effective May 20, 1999.

§312.82 Early consultation.

For products intended to treat life-threatening or severely-debilitating illnesses, sponsors may request to meet with FDA-reviewing officials early in the drug development process to review and reach agreement on the design of necessary preclinical and clinical studies. Where appropriate, FDA will invite to such meetings one or more outside expert scientific consultants or advisory committee members. To the extent FDA resources permit, agency reviewing officials will honor requests for such meetings.

(a) *Pre-investigational new drug (IND) meetings.* Prior to the submission of the initial IND, the sponsor may request a meeting with FDA-reviewing officials. The primary purpose of this meeting is to review and reach agreement on the design of animal studies needed to initiate human testing. The meeting may also provide an opportunity for discussing the scope and design of phase I testing, plans for studying the drug product in pediatric populations, and the best approach for presentation and formatting of data in the IND.

(b) *End-of-phase I meetings.* When data from phase I clinical testing are available, the sponsor may again request a meeting with FDA-reviewing officials. The primary purpose of this meeting is to review and reach agreement on the design of phase 2 controlled clinical trials, with the goal that such testing will be adequate to provide sufficient data on the drug's safety and effectiveness to support a decision on its approvability for marketing, and to discuss the need for, as well as the design and timing of, studies of the drug in pediatric patients. For drugs for life-threatening diseases, FDA will provide its best judgment, at that time, whether pediatric studies will be required and whether their submission will be

deferred until after approval. The procedures outlined in §312.47(b)(1) with respect to end-of-phase 2 conferences, including documentation of agreements reached, would also be used for end-of-phase 1 meetings.

[53 FR 41523, Oct. 21, 1988, as amended at 63 FR 66669, Dec. 2, 1998]

§312.83 Treatment protocols.

If the preliminary analysis of phase 2 test results appears promising, FDA may ask the sponsor to submit a treatment protocol to be reviewed under the procedures and criteria listed in §§312.34 and 312.35. Such a treatment protocol if requested and granted, would normally remain in effect while the complete data necessary for a marketing application are being assembled by the sponsor and reviewed by FDA (unless grounds exist for clinical hold of ongoing protocols, as provided in §312.42(b)(3)(ii)).

§312.84 Risk-benefit analysis in review of marketing applications for drugs to treat life-threatening and severely-debilitating illnesses.

(a) FDA's application of the statutory standards for marketing approval shall recognize the need for a medical risk-benefit judgment in making the final decision on approvability. As part of this evaluation, consistent with the statement of purpose in §312.80, FDA will consider whether the benefits of the drug outweigh the known and potential risks of the drug and the need to answer remaining questions about risks and benefits of the drug, taking into consideration the severity of the disease and the absence of satisfactory alternative therapy.

(b) In making decisions on whether to grant marketing approval for products that have been the subject of an end-of-phase 1 meeting under §312.82, FDA will usually seek the advice of outside expert scientific consultants or advisory committees. Upon the filing of such a marketing application under §314.101 or part 601 of this chapter, FDA will notify the members of the relevant advisory committee of the application's filing and its availability for review.

(c) If FDA concludes that the data presented are sufficient for mar-

keting approval, FDA will issue (for a drug) a not approvable letter pursuant to §314.120 of this chapter, or (for a biologic) a deficiencies letter consistent with the biological product licensing procedures. Such letter, in describing the deficiencies in the application, will address why the results of the research design agreed to under §312.82, or in subsequent meetings, have not provided sufficient evidence for marketing approval. Such letter will also describe any recommendations made by the advisory committee regarding the application.

(d) Marketing applications submitted under the procedures contained in this section will be subject to the requirements and procedures contained in part 314 or part 600 of this chapter, as well as those in this subpart.

§312.85 Phase 4 studies.

Concurrent with marketing approval, FDA may seek agreement from the sponsor to conduct certain post-marketing (phase 4) studies to delineate additional information about the drug's risks, benefits, and optimal use. These studies could include, but would not be limited to, studying different doses or schedules of administration than were used in phase 2 studies, use of the drug in other patient populations or other stages of the disease, or use of the drug over a longer period of time.

§312.86 Focused FDA regulatory research.

At the discretion of the agency, FDA may undertake focused regulatory research on critical rate-limiting aspects of the preclinical, chemical/manufacturing, and clinical phases of drug development and evaluation. When initiated, FDA will undertake such research efforts as a means for meeting a public health need in facilitating the development of therapies to treat life-threatening or severely debilitating illnesses.

§312.87 Active monitoring of conduct and evaluation of clinical trials.

For drugs covered under this section, the Commissioner and other agency officials will monitor the progress of the conduct and evaluation of clinical

trials and be involved in facilitating their appropriate progress.

§312.88 Safeguards for patient safety.

All of the safeguards incorporated within parts 50, 56, 312, 314, and 600 of this chapter designed to ensure the safety of clinical testing and the safety of products following marketing approval apply to drugs covered by this section. This includes the requirements for informed consent (part 50 of this chapter) and Institutional review boards (part 56 of this chapter). These safeguards further include the review of animal studies prior to initial human testing (§312.23), and the monitoring of adverse drug experiences through the requirements of IND safety reports (§312.32), safety update reports during agency review of a marketing application (§314.50 of this chapter), and postmarketing adverse reaction reporting (§314.80 of this chapter).

Subpart F—Miscellaneous

§312.110 Import and export requirements.

(a) *Imports.* An investigational new drug offered for import into the United States complies with the requirements of this part if it is subject to an IND that is in effect for it under §312.40 and: (1) The consignee in the United States is the sponsor of the IND; (2) the consignee is a qualified investigator named in the IND; or (3) the consignee is the domestic agent of a foreign sponsor, is responsible for the control and distribution of the investigational drug, and the IND identifies the consignee and describes what, if any, actions the consignee will take with respect to the investigational drug.

(b) *Exports.* An investigational new drug intended for export from the United States complies with the requirements of this part as follows:

(1) If an IND is in effect for the drug under §312.40 and each person who receives the drug is an investigator named in the application; or

(2) If FDA authorizes shipment of the drug for use in a clinical investigation. Authorization may be obtained as follows:

(i) Through submission to the International Affairs Staff (HFY-50), Asso-

ciate Commissioner for Health Affairs, Food and Drug Administration, 5600 Fishers Lane, Rockville, MD 20857, of a written request from the person that seeks to import the drug. A request must provide adequate information about the drug to satisfy FDA that the drug is appropriate for the proposed investigational use in humans, that the drug will be used for investigational purposes only, and that the drug may be legally used by that consignee in the importing country for the proposed investigational use. The request shall specify the quantity of the drug to be shipped per shipment and the frequency of expected shipments. If FDA authorizes exportation under this paragraph, the agency shall concurrently notify the government of the importing country of such authorization.

(ii) Through submission to the International Affairs Staff (HFY-50), Associate Commissioner for Health Affairs, Food and Drug Administration, 5600 Fishers Lane, Rockville, MD 20857, of a formal request from an authorized official of the government of the country to which the drug is proposed to be shipped. A request must specify that the foreign government has adequate information about the drug and the proposed investigational use, that the drug will be used for investigational purposes only, and that the foreign government is satisfied that the drug may legally be used by the intended consignee in that country. Such a request shall specify the quantity of drug to be shipped per shipment and the frequency of expected shipments.

(iii) Authorization to export an investigational drug under paragraph (b)(2)(i) or (ii) of this section may be revoked by FDA if the agency finds that the conditions underlying its authorization are not longer met.

(3) This paragraph applies only where the drug is to be used for the purpose of clinical investigation.

(4) This paragraph does not apply to the export of new drugs (including biological products, antibiotic drugs, and insulin) approved or authorized for export under section 802 of act (21 U.S.C. 382) or section 351(h), (A) of the

Public Health Service Act (42 U.S.C. 262(h)(1)(A)).

(Collection of information requirements approved by the Office of Management and Budget under control number 0910-0014)

(52 FR 8831, Mar. 19, 1987, as amended at 52 FR 23031, June 17, 1987; 64 FR 401, Jan. 5, 1999)

EFFECTIVE DATE NOTE: At 64 FR 401, Jan. 5, 1999, §312.110 was amended by revising paragraph (b)(4) and by removing paragraph (b)(5), effective May 20, 1999. For the convenience of the user, the superseded text follows:

§312.110 Import and export requirements.

(b)***

(4) This paragraph does not apply to the export of an antibiotic drug product shipped in accordance with the provisions of section 801(d) of the act.

(5) This paragraph does not apply to the export of new drugs (including biological products) approved for export under section 802 of the act or section 351(h)(1)(A) of the Public Health Service Act.

§312.120 Foreign clinical studies not conducted under an IND.

(a) Introduction. This section describes the criteria for acceptance by FDA of foreign clinical studies not conducted under an IND. In general, FDA accepts such studies provided they are well designed, well conducted, performed by qualified investigators, and conducted in accordance with ethical principles acceptable to the world community. Studies meeting these criteria may be utilized to support clinical investigations in the United States and/or marketing approval. Marketing approval of a new drug based solely on foreign clinical data is governed by §314.106.

(b) Data submissions. A sponsor who wishes to rely on a foreign clinical study to support an IND or to support an application for marketing approval shall submit to FDA the following information:

- (1) A description of the investigator's qualifications;
- (2) A description of the research facilities;
- (3) A detailed summary of the protocol and results of the study, and

should FDA request, certain records maintained by the investigator or additional background data such as hospital or other institutional records;

(4) A description of the drug substance and drug product used in the study, including a description of components, formulation, specifications, and bioavailability of the specific drug product used in the clinical study, if available; and

(5) If the study is intended to support the effectiveness of a drug product, information showing that the study is adequate and well controlled under §314.126.

(c) Conformance with ethical principles.

(1) Foreign clinical research is required to have been conducted in accordance with the ethical principles stated in the "Declaration of Helsinki" (see paragraph (c)(4) of this section) or the laws and regulations of the country in which the research was conducted, whichever represents the greater protection of the individual.

(2) For each foreign clinical study submitted under this section, the sponsor shall explain how the research conformed to the ethical principles contained in the "Declaration of Helsinki" or the foreign country's standards, whichever were used. If the foreign country's standards were used, the sponsor shall explain in detail how those standards differ from the "Declaration of Helsinki" and how they offer greater protection.

(3) When the research has been approved by an independent review committee, the sponsor shall submit to FDA documentation of such review and approval, including the names and qualifications of the members of the committee. In this regard, a "review committee" means a committee composed of scientists and, where practicable, individuals who are otherwise qualified (e.g., other health professionals or laymen). The investigator may not vote on any aspect of the review of his or her protocol by a review committee.

(4) The "Declaration of Helsinki" states as follows:

RECOMMENDATIONS GUIDING PHYSICIANS IN BIOMEDICAL RESEARCH INVOLVING HUMAN SUBJECTS

Introduction

It is the mission of the physician to safeguard the health of the people. His or her knowledge and conscience are dedicated to the fulfillment of this mission.

The Declaration of Geneva of the World Medical Association binds the physician with the words, "The health of my patient will be my first consideration," and the International Code of Medical Ethics declares that, "A physician shall act only in the patient's interest when providing medical care which might have the effect of weakening the physical and mental condition of the patient."

The purpose of biomedical research involving human subjects must be to improve diagnostic, therapeutic and prophylactic procedures and the understanding of the aetiology and pathogenesis of disease.

In current medical practice most diagnostic, therapeutic or prophylactic procedures involve hazards. This applies especially to biomedical research.

Medical progress is based on research which ultimately must rest in part on experimentation involving human subjects.

In the field of biomedical research a fundamental distinction must be recognized between medical research in which the aim is essentially diagnostic or therapeutic for a patient, and medical research, the essential object of which is purely scientific and without implying direct diagnostic or therapeutic value to the person subjected to the research.

Special caution must be exercised in the conduct of research which may affect the environment, and the welfare of animals used for research must be respected.

Because it is essential that the results of laboratory experiments be applied to human beings to further scientific knowledge and to help suffering humanity, the World Medical Association has prepared the following recommendations as a guide to every physician in biomedical research involving human subjects. They should be kept under review in the future. It must be stressed that the standards as drafted are only a guide to physicians all over the world. Physicians are not relieved from criminal, civil and ethical responsibilities under the laws of their own countries.

I. Basic Principles

1. Biomedical research involving human subjects must conform to generally accepted scientific principles and should be based on adequately performed laboratory and animal experimentation and on a thorough knowledge of the scientific literature.

2. The design and performance of each experimental procedure involving human subjects should be clearly formulated in an experimental protocol which should be transmitted for consideration, comment and guidance to a specially appointed committee independent of the investigator and the sponsor provided that this independent committee is in conformity with the laws and regulations of the country in which the research experiment is performed.

3. Biomedical research involving human subjects should be conducted only by scientifically qualified persons and under the supervision of a clinically competent medical person. The responsibility for the human subject must always rest with a medically qualified person and never rest on the subject of the research, even though the subject has given his or her consent.

4. Biomedical research involving human subjects cannot legitimately be carried out unless the importance of the objective is in proportion to the inherent risk to the subject.

5. Every biomedical research project involving human subjects should be preceded by careful assessment of predictable risks in comparison with foreseeable benefits to the subject or to others. Concern for the interests of the subject must always prevail over the interests of science and society.

6. The right of the research subject to safeguard his or her integrity must always be respected. Every precaution should be taken to respect the privacy of the subject and to minimize the impact of the study on the subject's physical and mental integrity and on the personality of the subject.

7. Physicians should abstain from engaging in research projects involving human subjects unless they are satisfied that the hazards involved are believed to be predictable. Physicians should cease any investigation if the hazards are found to outweigh the potential benefits.

8. In publication of the results of his or her research, the physician is obliged to preserve the accuracy of the results. Reports of experimentation not in accordance with the principles laid down in this Declaration should not be accepted for publication.

9. In any research on human beings, each potential subject must be adequately informed of the aims, methods, anticipated benefits and potential hazards of the study and the discomfort it may entail. He or she should be informed that he or she is at liberty to abstain from participation in the study and that he or she is free to withdraw his or her consent to participation at any time. The physician should then obtain the subject's freely-given informed consent, preferably in writing.

10. When obtaining informed consent for the research project the physician should be particularly cautious if the subject is in a

dependent relationship to him or her or may consent under duress. In that case the informed consent should be obtained by a physician who is not engaged in the investigation and who is completely independent of this official relationship.

11. In case of legal incompetence, informed consent should be obtained from the legal guardian in accordance with national legislation. Where physical or mental incapacity makes it impossible to obtain informed consent, or when the subject is a minor, permission from the responsible relative replaces that of the subject in accordance with national legislation.

Whenever the minor child is in fact able to give a consent, the minor's consent must be obtained in addition to the consent of the minor's legal guardian.

12. The research protocol should always contain a statement of the ethical considerations involved and should indicate that the principles enunciated in the present Declaration are complied with.

II. Medical Research Combined with Professional Care (Clinical Research)

1. In the treatment of the sick person, the physician must be free to use a new diagnostic and therapeutic measure, if in his or her judgment it offers hope of saving life, re-establishing health or alleviating suffering.

2. The potential benefits, hazards and discomfort of a new method should be weighed against the advantages of the best current diagnostic and therapeutic methods.

3. In any medical study, every patient—including those of a control group, if any—should be assured of the best proven diagnostic and therapeutic method.

4. The refusal of the patient to participate in a study must never interfere with the physician-patient relationship.

5. If the physician considers it essential not to obtain informed consent, the specific reasons for this proposal should be stated in the experimental protocol for transmission to the independent committee (I, 2).

6. The physician can combine medical research with professional care, the objective being the acquisition of new medical knowledge, only to the extent that medical research is justified by its potential diagnostic or therapeutic value for the patient.

III. Non-Therapeutic Biomedical Research Involving Human Subjects (Non-Clinical Biomedical Research)

1. In the purely scientific application of medical research carried out on a human being, it is the duty of the physician to remain the protector of the life and health of that person on whom biomedical research is being carried out.

2. The subjects should be volunteers—either healthy persons or patients for whom

the experimental design is not related to the patient's illness.

3. The investigator or the investigating team should discontinue the research if in his/her or their judgment it may, if continued, be harmful to the individual.

4. In research on man, the interest of science and society should never take precedence over considerations related to the well-being of the subject.

(Collection of information requirements approved by the Office of Management and Budget under control number 0910-0014)

[52 FR 8831, Mar. 19, 1987, as amended at 52 FR 23031, June 17, 1987; 56 FR 22113, May 14, 1991; 64 FR 401, Jan. 5, 1999]

EFFECTIVE DATE NOTE: At 64 FR 401, Jan. 5, 1999, §312.120 was amended by removing "or antibiotic drug" from the last sentence of paragraph (a), effective May 20, 1999.

§312.130 Availability for public disclosure of data and information in an IND.

(a) The existence of an investigational new drug application will not be disclosed by FDA unless it has previously been publicly disclosed or acknowledged.

(b) The availability for public disclosure of all data and information in an investigational new drug application for a new drug will be handled in accordance with the provisions established in §314.430 for the confidentiality of data and information in applications submitted in part 314. The availability for public disclosure of all data and information in an investigational new drug application for a biological product will be governed by the provisions of §§601.50 and 601.51.

(c) Notwithstanding the provisions of §314.430, FDA shall disclose upon request to an individual to whom an investigational new drug has been given a copy of any IND safety report relating to the use in the individual.

(d) The availability of information required to be publicly disclosed for investigations involving an exception from informed consent under §50.24 of this chapter will be handled as follows: Persons wishing to request the publicly disclosable information in the IND that was required to be filed in Docket Number 95S-0158 in the Dockets Management Branch (HFA-305), Food and Drug Administration, 12420 Parklawn Dr., rm. 1-23, Rockville, MD 20857, shall

submit a request under the Freedom of Information Act.

[52 FR 8831, Mar. 19, 1987, redesignated at 53 FR 41523, Oct. 21, 1988, as amended at 61 FR 51530, Oct. 2, 1996; 64 FR 401, Jan. 5, 1999]

EFFECTIVE DATE NOTE: At 64 FR 401, Jan. 5, 1999, §312.130 was amended by removing "or antibiotic drug" from paragraph (b), effective May 20, 1999.

§312.140 Address for correspondence.

(a) Except as provided in paragraph (b) of this section, a sponsor shall send an initial IND submission to the Central Document Room, Center for Drug Evaluation and Research, Food and Drug Administration, Park Bldg., Rm. 214, 12420 Parklawn Dr., Rockville, MD 20852. On receiving the IND, FDA will inform the sponsor which one of the divisions in the Center for Drug Evaluation and Research or the Center for Biologics Evaluation and Research is responsible for the IND. Amendments, reports, and other correspondence relating to matters covered by the IND should be directed to the appropriate division. The outside wrapper of each submission shall state what is contained in the submission, for example, "IND Application", "Protocol Amendment", etc.

(b) Applications for the products listed below should be submitted to the Division of Biological Investigational New Drugs (HFB-230), Center for Biologics Evaluation and Research, Food and Drug Administration, 8800 Rockville Pike, Bethesda, MD 20892. (1) Products subject to the licensing provisions of the Public Health Service Act of July 1, 1944 (58 Stat. 682, as amended (42 U.S.C. 201 et seq.)) or subject to part 600; (2) ingredients packaged together with containers intended for the collection, processing, or storage of blood or blood components; (3) urokinase products; (4) plasma volume expanders and hydroxyethyl starch for leukapheresis; and (5) coupled antibodies, i.e., products that consist of an antibody component coupled with a drug or radionuclide component in which both components provide a pharmacological effect but the biological component determines the site of action.

(c) All correspondence relating to biological products for human use which are also radioactive drugs shall be submitted to the Division of Oncology and Radiopharmaceutical Drug Products (HFD-150), Center for Drug Evaluation and Research, Food and Drug Administration, 5600 Fishers Lane, Rockville, MD 20857, except that applications for coupled antibodies shall be submitted in accordance with paragraph (b) of this section.

(d) All correspondence relating to export of an investigational drug under §312.110(b)(2) shall be submitted to the International Affairs Staff (HPY-50), Office of Health Affairs, Food and Drug Administration, 5600 Fishers Lane, Rockville, MD 20857.

(Collection of information requirements approved by the Office of Management and Budget under control number 0910-0014)

[52 FR 8831, Mar. 19, 1987, as amended at 52 FR 23031, June 17, 1987; 55 FR 11580, Mar. 29, 1990]

§312.145 Guidelines.

(a) FDA has made available guidelines under §10.90(b) to help persons to comply with certain requirements of this part.

(b) The Center for Drug Evaluation and Research and the Center for Biologics Evaluation and Research maintain lists of guidelines that apply to the Centers' regulations. The lists state how a person can obtain a copy of each guideline. A request for a copy of the lists should be directed to the CDER Executive Secretariat Staff (HFD-6), Center for Drug Evaluation and Research, Food and Drug Administration, 5600 Fishers Lane, Rockville, MD 20857, for drug products, and the Congressional, Consumer, and International Affairs Staff (HFB-142), Center for Biologics Evaluation and Research, Food and Drug Administration, 8800 Rockville Pike, Bethesda, MD 20892, for biological products.

[52 FR 8831, Mar. 19, 1987, as amended at 55 FR 11580, Mar. 29, 1990; 56 FR 776, Jan. 31, 1991; 57 FR 10814, Mar. 31, 1992]

Subpart G—Drugs for Investigational Use in Laboratory Research Animals or In Vitro Tests

§312.160 Drugs for investigational use in laboratory research animals or in vitro tests.

(a) *Authorization to ship.* (1)(i) A person may ship a drug intended solely for tests in vitro or in animals used only for laboratory research purposes if it is labeled as follows:

CAUTION: Contains a new drug for investigational use only in laboratory research animals, or for tests in vitro. Not for use in humans.

(ii) A person may ship a biological product for investigational in vitro diagnostic use that is listed in §312.2(b)(2)(ii) if it is labeled as follows:

CAUTION: Contains a biological product for investigational in vitro diagnostic tests only.

(2) A person shipping a drug under paragraph (a) of this section shall use due diligence to assure that the consignee is regularly engaged in conducting such tests and that the shipment of the new drug will actually be used for tests in vitro or in animals used only for laboratory research.

(3) A person who ships a drug under paragraph (a) of this section shall maintain adequate records showing the name and post office address of the expert to whom the drug is shipped and the date, quantity, and batch or code mark of each shipment and delivery. Records of shipments under paragraph (1)(i) of this section are to be maintained for a period of 2 years after the shipment. Records and reports of data and shipments under paragraph (1)(ii) of this section are to be maintained in accordance with §312.57(b). The person who ships the drug shall, upon request from any properly authorized officer or employee of the Food and Drug Administration, at reasonable times, permit such officer or employee to have access to and copy and verify records required to be maintained under this section.

(b) *Termination of authorization to ship.* FDA may terminate authorization to ship a drug under this section if it finds that:

(1) The sponsor of the investigation has failed to comply with any of the conditions for shipment established under this section; or

(2) The continuance of the investigation is unsafe or otherwise contrary to the public interest or the drug is used for purposes other than bona fide scientific investigation. FDA will notify the person shipping the drug of its finding and invite immediate correction. If correction is not immediately made, the person shall have an opportunity for a regulatory hearing before FDA pursuant to part 16.

(c) *Disposition of unused drug.* The person who ships the drug under paragraph (a) of this section shall assure the return of all unused supplies of the drug from individual investigators whenever the investigation discontinues or the investigation is terminated. The person who ships the drug may authorize in writing alternative disposition of unused supplies of the drug provided this alternative disposition does not expose humans to risks from the drug, either directly or indirectly (e.g., through food-producing animals). The shipper shall maintain records of any alternative disposition.

(Collection of information requirements approved by the Office of Management and Budget under control number 0910-0014)

[52 FR 8831, Mar. 19, 1987, as amended at 52 FR 23031, June 17, 1987. Redesignated at 53 FR 41523, Oct. 21, 1988]

PART 314—APPLICATIONS FOR FDA APPROVAL TO MARKET A NEW DRUG

Subpart A—General Provisions

Sec.

314.1 Scope of this part.

314.2 Purpose.

314.3 Definitions.

Subpart B—Applications

314.50 Content and format of an application.

314.52 Notice of certification of invalidity or noninfringement of a patent.

314.53 Submission of patent information.

314.54 Procedure for submission of an application requiring investigations for approval of a new indication for, or other change from, a listed drug.

314.55 Pediatric use information.

314.60 Amendments to an unapproved application.

314.65 Withdrawal by the applicant of an unapproved application.

314.70 Supplements and other changes to an approved application.

314.71 Procedures for submission of a supplement to an approved application.

314.72 Change in ownership of an application.

314.80 Postmarketing reporting of adverse drug experiences.

314.81 Other postmarketing reports.

314.90 Waivers.

Subpart C—Abbreviated Applications

314.92 Drug products for which abbreviated applications may be submitted.

314.93 Petition to request a change from a listed drug.

314.94 Content and format of an abbreviated application.

314.95 Notice of certification of invalidity or noninfringement of a patent.

314.96 Amendments to an unapproved abbreviated application.

314.97 Supplements and other changes to an approved abbreviated application.

314.98 Postmarketing reports.

314.99 Other responsibilities of an applicant of an abbreviated application.

Subpart D—FDA Action on Applications and Abbreviated Applications

314.100 Timeframes for reviewing applications and abbreviated applications.

314.101 Filing an application and receiving an abbreviated new drug application.

314.102 Communications between FDA and applicants.

314.103 Dispute resolution.

314.104 Drugs with potential for abuse.

314.105 Approval of an application and an abbreviated application.

314.106 Foreign data.

314.107 Effective date of approval of a 505(b)(2) application or abbreviated new drug application under section 505(j) of the act.

314.108 New drug product exclusivity.

314.110 Approvable letter to the applicant.

314.120 Not approvable letter to the applicant.

314.122 Submitting an abbreviated application for, or a 505(j)(2)(C) petition that relies on, a listed drug that is no longer marketed.

314.125 Refusal to approve an application.

314.126 Adequate, and well-controlled studies.

314.127 Refusal to approve an abbreviated new drug application.

314.128 Withdrawal of approval of an application or abbreviated application.

314.151 Withdrawal of approval of an abbreviated new drug application under section 505(j)(8) of the act.

314.153 Notice of withdrawal of approval of an application or abbreviated application for a new drug.

314.153 Suspension of approval of an abbreviated new drug application.

314.160 Approval of an application or abbreviated application for which approval was previously refused, suspended, or withdrawn.

314.161 Determination of reasons for voluntary withdrawal of a listed drug.

314.162 Removal of a drug product from the list.

314.170 Adulteration and misbranding of an approved drug.

Subpart E—Hearing Procedures for New Drugs

314.200 Notice of opportunity for hearing; notice of participation and request for hearing; grant or denial of hearing.

314.201 Procedure for hearings.

314.235 Judicial review.

Subpart F—Administrative Procedures for Antibiotics

314.300 Procedure for the issuance, amendment, or repeal of regulations.

Subpart G—Miscellaneous Provisions

314.410 Imports and exports of new drugs.

314.420 Drug master files.

314.430 Availability for public disclosure of data and information in an application or abbreviated application.

314.440 Addresses for applications and abbreviated applications.

314.445 Guidelines.

Subpart H—Accelerated Approval of New Drugs for Serious or Life-Threatening Illnesses

314.500 Scope.

314.510 Approval based on a surrogate endpoint or on an effect on a clinical endpoint other than survival or irreversible morbidity.

314.520 Approval with restrictions to assure safe use.

314.530 Withdrawal procedures.

314.540 Postmarketing safety reporting.

314.550 Promotional materials.

314.560 Termination of requirements.

AUTHORITY: 21 U.S.C. 321, 331, 351, 352, 353, 355, 371, 374, 379e.

SOURCE: 50 FR 7493, Feb. 22, 1985, as otherwise noted.

ATTACHMENT I

**Copy of BLA Submission Acknowledgement
Letter from FDA**



DEPARTMENT OF HEALTH AND HUMAN SERVICES

Food and Drug Administration
Silver Spring MD 20993

Our STN: BL 125387/0

BLA ACKNOWLEDGEMENT
March 8, 2011

Regeneron Pharmaceuticals, Inc.
Attention: Laura Pologe, Ph.D.
Associate Director, Regulatory Affairs
777 Old Saw Mill River Road
Tarrytown, New York 10591-6707

Dear Dr. Pologe:

We have received your Biologics License Application (BLA) submitted under section 351 of the Public Health Service Act (PHS Act) for the following:

Name of Biological Product: Aflibercept Ophthalmic Injection

Date of Application: February 17, 2011

Date of Receipt: February 18, 2011

Our Submission Tracking Number (STN): BL 125387/0

Proposed Use: Neovascular (Wet) Age-Related Macular Degeneration

If you have not already done so, promptly submit the content of labeling [21 CFR 601.14(b)] in structured product labeling (SPL) format as described at <http://www.fda.gov/oc/datacouncil/spl.html>. Failure to submit the content of labeling in SPL format may result in a refusal-to-file action. The content of labeling must conform to the format and content requirements of revised 21 CFR 201.56-57.

You are also responsible for complying with the applicable provisions of sections 402(i) and 402(j) of the Public Health Service Act (PHS Act) [42 USC §§ 282 (i) and (j)], which was amended by Title VIII of the Food and Drug Administration Amendments Act of 2007 (FDAAA) (Public Law No. 110-85, 121 Stat. 904).

The BLA Submission Tracking Number provided above should be cited at the top of the first page of all submissions to this application. Send all submissions, electronic or paper, including those sent by overnight mail or courier, to the following address:

Food and Drug Administration
Center for Drug Evaluation and Research
Therapeutic Biological Products Document Room
5901-B Ammendale Road
Beltsville, MD 20705-1266

All regulatory documents submitted in paper should be three-hole punched on the left side of the page and bound. The left margin should be at least three-fourths of an inch to assure text is not obscured in the fastened area. Standard paper size (8-1/2 by 11 inches) should be used; however, it may occasionally be necessary to use individual pages larger than standard paper size. Non-standard, large pages should be folded and mounted to allow the page to be opened for review without disassembling the jacket and refolded without damage when the volume is shelved. Shipping unbound documents may result in the loss of portions of the submission or an unnecessary delay in processing which could have an adverse impact on the review of the submission.

If you have any questions, call Michael Puglisi, Regulatory Project Manager, at (301) 796-0791.

Sincerely,



/Maureen P. Dillon-Parker/

Maureen P. Dillon-Parker
Chief, Project Management Staff
Division of Anti-Infective and Ophthalmology Products
Office of Antimicrobial Products
Center for Drug Evaluation and Research