



[54] HIGH SPEED SAMPLE AND HOLD CIRCUIT AND RADIO CONSTRUCTED THEREWITH

[75] Inventors: Thomas E. Schiltz, Chandler; Carl R. Nuckolls, Fountain Hills, both of Ariz.

[73] Assignee: Motorola, Inc., Schaumburg, Ill.

[21] Appl. No.: 985,477

[22] Filed: Dec. 3, 1992

[51] Int. Cl.⁵ H04B 1/28; H03K 5/159

[52] U.S. Cl. 455/333; 455/313; 455/318; 307/353

[58] Field of Search 455/313, 318, 323, 319, 455/343, 333, 334, 316; 307/352, 353; 328/151

[56] References Cited

U.S. PATENT DOCUMENTS

Re. 32,314	12/1986	Gittins et al.	455/263
3,602,825	8/1971	Senior	307/352
4,066,919	1/1978	Huntington	307/353
4,370,572	1/1983	Cosand et al.	307/353
4,389,579	6/1983	Stein	307/353
4,612,464	9/1986	Ishikawa et al.	307/352
4,801,823	1/1989	Yokoyama	307/353
4,806,790	2/1989	Sone	307/353
4,910,752	3/1990	Yester, Jr. et al.	455/343
4,922,452	5/1990	Larsen et al.	365/45
4,970,703	11/1990	Hariharan et al.	367/138
5,017,924	5/1991	Guiberteau et al.	342/195

OTHER PUBLICATIONS

An article entitled "Accurately Model Unbiased FETs for Monolithic Switches", by C. Kermarrec et al. of Tachonics Corp., from *Microwaves & RF*, Jun. 1989.

An article entitled "Waveform Sampling with Schottky Diodes" *Hewlett Packard Components Application Bulletin* 16, 5952-9818 (Nov. 1976).

An article entitled "A 1-GHz 6-bit ADC System" by Ken Poulton et al., *IEEE Journal of Solid-State Circuits*, vol. SC-22, No. 6, Dec. 1987, pp. 962-969.

An article entitled "Characterization of Microwave Integrated Circuits Using an Optical Phase-Locking and Sampling System", by H-L. A. Hung et al. of COMSAT Laboratories, Clarksburg, Md., *IEEE MTT-S Digest*, 1991, pp. 507-510.

An article entitled "Computer-Aided Noise analysis of MESFET and HEMT Mixers", by V. Rizzoli et al., *IEEE Transactions on Microwave Theory and Techniques*, vol. 37, No. 9, Sep. 1989, pp. 1401-1410.

An article entitled "Novel GaAs FET Phase Detector Operable to Ka Band" T. Takano et al. Fujitsu Laboratories Ltd., Kawasaki, Japan, *IEEE MTT-S Digest*, 1984, pp. 381-383.

An article entitled "130 GHz GaAs Monolithic Integrated Circuit Sampling Head", by R. A. Marsland et al. of Edward L. Ginzton Laboratory, Stanford University, Stanford, Calif., *1989 American Institute of Physics, Appl. Phys. Lett.* 55(6), 7 Aug. 1989, pp. 592-594.

An article entitled "RF Sampling Gates: a brief review", by N. P. Akers et al., *IEE Proceedings*, vol. 133, Pt. A. No. 1, Jan. 1986, pp. 45-49.

(List continued on next page.)

Primary Examiner—Reinhard J. Eisenzopf

Assistant Examiner—Nguyen Vo

Attorney, Agent, or Firm—Frederick M. Fliegel; Robert M. Handy

[57] ABSTRACT

A sample and hold circuit is formed within an integrated circuit and has a small, substantially linear hold capacitance. The circuit includes a sampling switch, a hold capacitor, and a buffer amplifier. The buffer amplifier includes a common drain FET and a constant current FET. The common drain FET provides an input which couples to the hold capacitor. The constant current FET isolates the source of the common drain FET from ground. The sample and hold circuit may be used as a wide bandwidth mixer. In a radio application, a pulse generator provides a stream of pulses in which the sampling rate times an integer number equals the RF frequency minus the IF frequency. The width of the sampling pulse is less than the period of an RF signal. In an oscillator application, the sample and hold circuit operates as a mixer in a frequency multiplying phase locked loop.

17 Claims, 3 Drawing Sheets

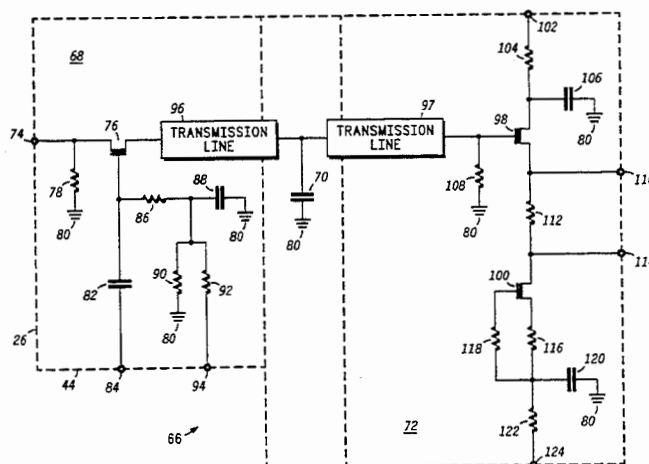

LC Ex 1006

OTHER PUBLICATIONS

- An article entitled "Sampling for Oscilloscopes and Other RF Systems: Dc through X-Band", by W. M. Grove, *IEEE Transactions on Microwave Theory and Techniques*, vol. MTT-14, No. 12, Dec. 1966, pp. 629-635.
- An article entitled "Sampling Loops Lock Sources to 23 GHz", *Microwaves & RF*, Sep. 1990.
- An article entitled "Subharmonic Sampling for the Measurement of Short-Term Stability of Microwave Oscillators" by N. D. Faulkner et al., *IEEE Transactions on Instrumentation and Measurement*, vol. IM-32, No. 1, Mar. 1983, pp. 208-213.
- An article entitled "Sub-Nanosecond Single-Shot Digitizing Using the HP 54111D", *Hewlett Packard Product Note HP 54111D-1*, Mar. 1988.
- An article entitled "2.4 GHz MESFET Sampler", by H. Hafdallah et al., Institut d'Electronique Fondamentale, Universite Paris, France, 10th Dec. 1987.
- An article entitled "Readout", *Electronic Engineering*, Mar. 1987, pp. 77-79.

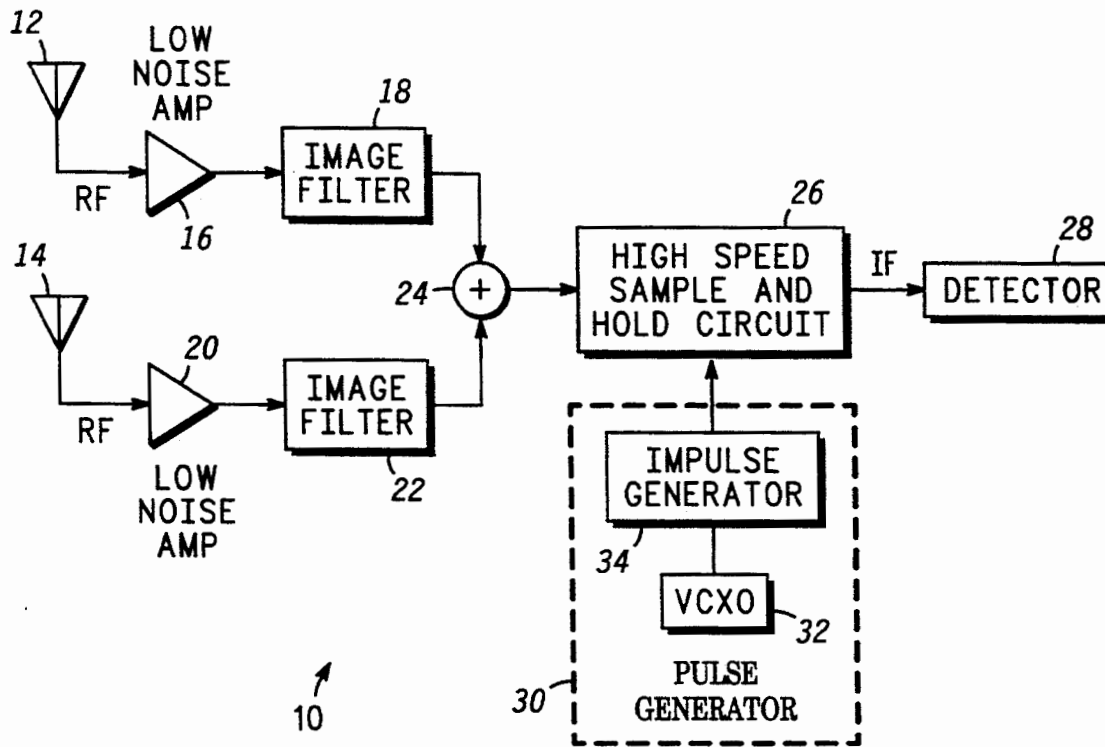
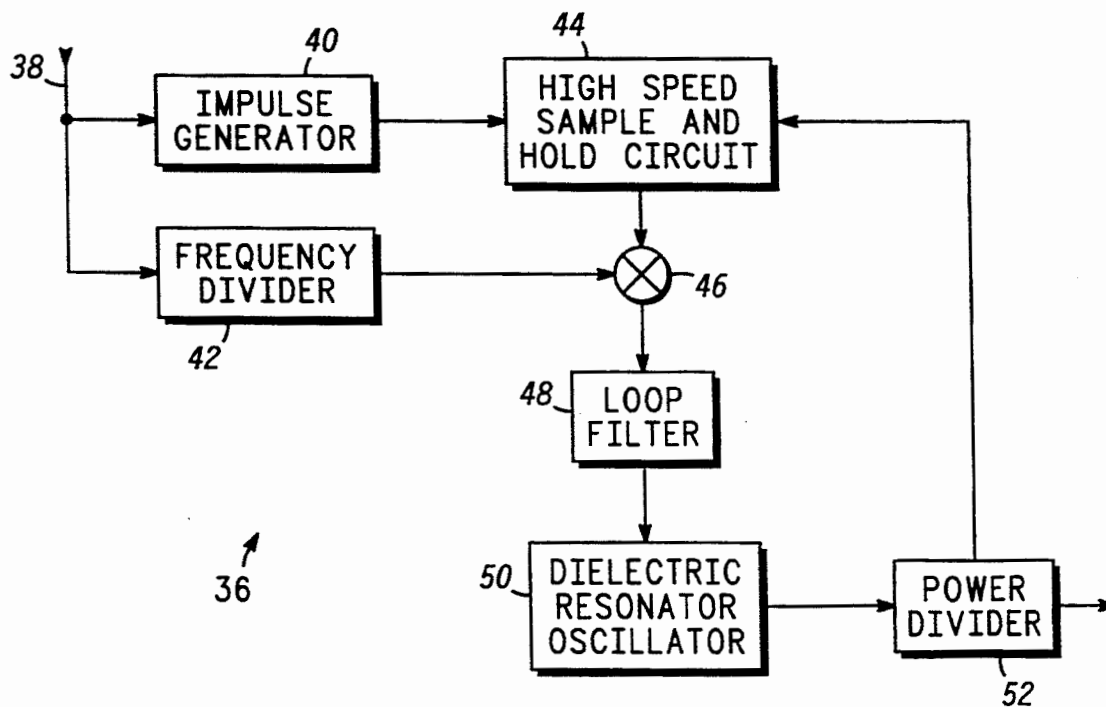

FIG. 1

FIG. 2



36

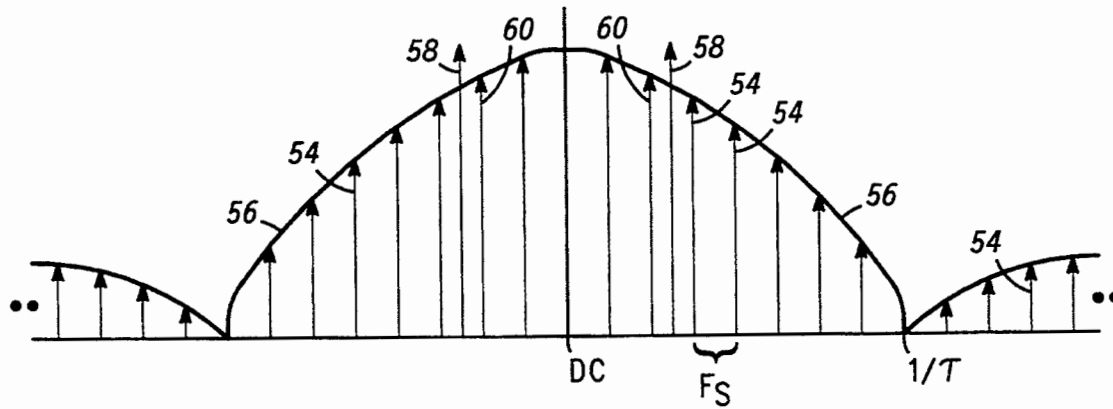
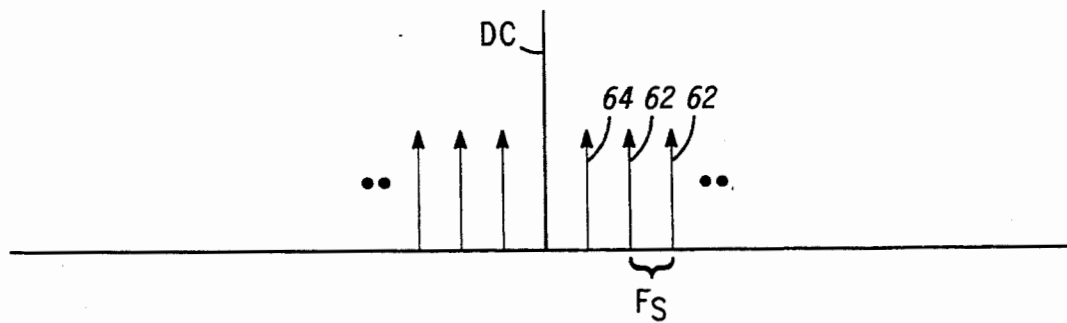
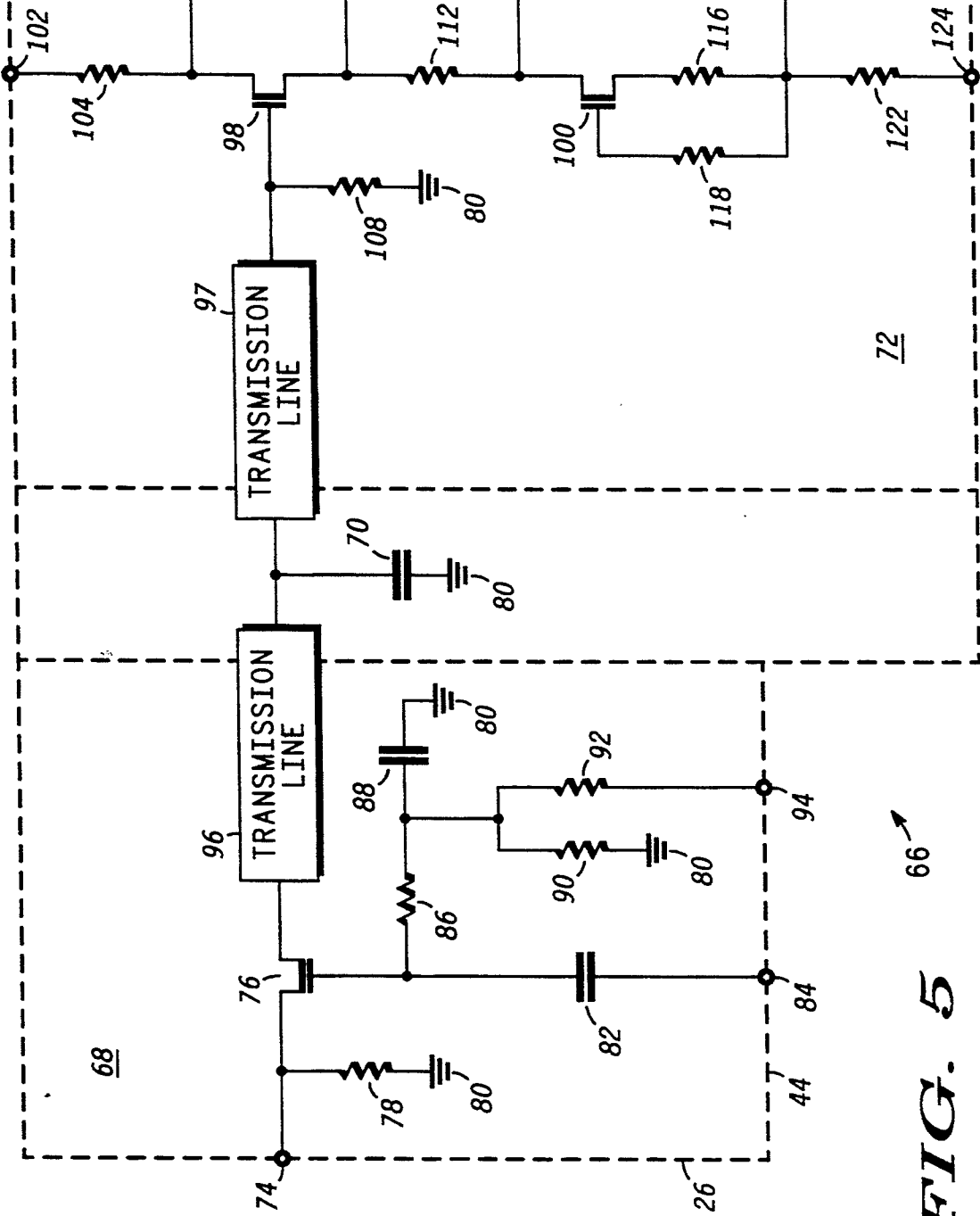

FIG. 3

FIG. 4





66

FIG. 5

Explore Litigation Insights

Docket Alarm provides insights to develop a more informed litigation strategy and the peace of mind of knowing you're on top of things.

Real-Time Litigation Alerts



Keep your litigation team up-to-date with **real-time alerts** and advanced team management tools built for the enterprise, all while greatly reducing PACER spend.

Our comprehensive service means we can handle Federal, State, and Administrative courts across the country.

Advanced Docket Research



With over 230 million records, Docket Alarm's cloud-native docket research platform finds what other services can't. Coverage includes Federal, State, plus PTAB, TTAB, ITC and NLRB decisions, all in one place.

Identify arguments that have been successful in the past with full text, pinpoint searching. Link to case law cited within any court document via Fastcase.

Analytics At Your Fingertips



Learn what happened the last time a particular judge, opposing counsel or company faced cases similar to yours.

Advanced out-of-the-box PTAB and TTAB analytics are always at your fingertips.

API

Docket Alarm offers a powerful API (application programming interface) to developers that want to integrate case filings into their apps.

LAW FIRMS

Build custom dashboards for your attorneys and clients with live data direct from the court.

Automate many repetitive legal tasks like conflict checks, document management, and marketing.

FINANCIAL INSTITUTIONS

Litigation and bankruptcy checks for companies and debtors.

E-DISCOVERY AND LEGAL VENDORS

Sync your system to PACER to automate legal marketing.