

ELECTRONIC DESIGN

TECHNOLOGY • APPLICATIONS • PRODUCTS • SOLUTIONS

A PENTON PUBLICATION \$10.00

DECEMBER 1, 1997

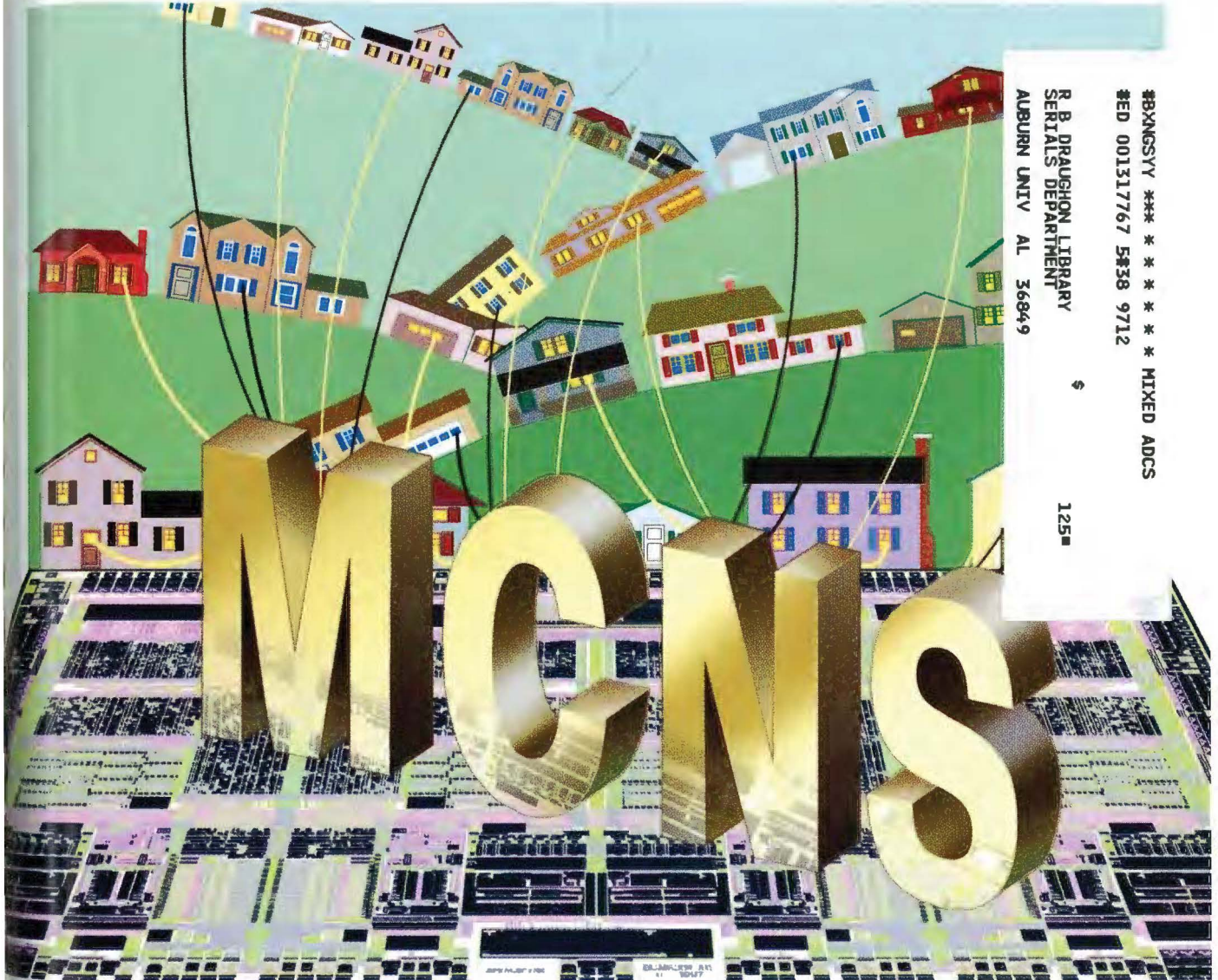

#BXNGSSYY ***
#ED 001317767 5#38 9712
R.B. DRAUGHON LIBRARY
SERIALS DEPARTMENT
AUBURN UNIV AL 36849

\$ 125⁰⁰

MCNS/DOCSIS MAC Clears Path For Cable-Modem Invasion p. 69

Annual IEDM Conference Examines Leading-Edge Device Developments p. 39

At IEDM: Memory, Logic Power Devices, EDA, Sensors, And Displays p. 40

Line-Driver Design For Broadband Communications Applications p. 81

Parasitic Extraction Tools Aid DSM IC Designs p.97

Harness The Power Of The ACPI/Smart Battery Standard p. 113

**DOCKET
ALARM**

Find authenticated court documents without watermarks at docketalarm.com.



If you're charged with designing low-power applications,
this little core is a mighty big friend. Motorola's new M-CORE
microRISC engine reduces costs, lengthens battery life and gives you
performance for the future. A combination of brains and brawn.

A 48MIPS/50MHz RISC core design with I/O intelligence
and interrupt performance built in. Plus, its development
tool chains are fully complete and validated to interoperate,
greatly reducing design time. In other words, it's ready to fly!

To find out how Motorola can help you save the day,
direct your mouse to www.motorola.com/mcore

or call 800.521.6274.



MOTOROLA
Semiconductor Products Sector

What you never thought possible.™

ELECTRONIC DESIGN

TECHNOLOGY • APPLICATIONS • PRODUCTS • SOLUTIONS

December 1, 1997 Volume 45, Number 27

EDITORIAL OVERVIEW



■ MCNS/DOCSIS MAC Clears Path For Cable-Modem Invasion 69

■ Annual IEDM Conference Examines Leading-Edge Device Developments 39

■ At IEDM: Memory, Logic Power Devices, EDA, Sensors, And Displays 40

■ Line-Driver Design For Broadband Communications Applications 81

■ Parasitic Extraction Tools Aid DSM IC Designs 97

■ Harness The Power Of The ACPI/Smart-Battery Standard 113

■ Pick The Perfect Chassis To Ensure System Longevity 127

TECH INSIGHTS

39 Annual IEDM Conference Examines Leading-Edge Device Developments

• Hear about the latest in memory and logic ICs, compound semiconductor devices, simulation tools, and sensors and displays.

40 Memory And Logic Structures Are Getting Faster And Denser

• Designers detail advanced process techniques and finer-dimension design rules at IEDM to build next-generation memories and logic.

48 Rivalries Between Silicon And Exotic Semiconductors Abound At IEDM

• SiGe and vanilla silicon move into RF and optical applications as compound semiconductors stake out their niches.

TECH INSIGHTS

50 IEDM Focuses On Advanced Device Models

• Models offer new hope in tackling deep-submicron issues dealing with process accuracy and interconnect.

60 Sensors And Displays Highlighted At IEDM

• Advanced device structures and new technologies are opening the door for emerging display and sensor-based applications.

COMMUNICATIONS TECHNOLOGY

69 MCNS/DOCSIS MAC Paves The Way For A Cable-Modem Invasion

• The first standards-compliant chip means affordable, interoperable, cable modems, with speed and security features.

COVER STORY

DEPARTMENTS

Upcoming Meetings ... 12,
..... 16, 18, 54

Editorial 22

• *Tiny Engines Fuel A Revolution*

Technology Briefing 24

• *Consumer Electronics' Potential*

Technology Newsletter 27, 30

Technology Breakthrough 33

• *35-GHz 0.5-W GaAs pHEMT points the way toward low-cost volume production of MOCVD MMICs*

• *0.1-mm electrostatic microrelays switch at up to 100 GHz*

• *Development of blue phosphor spawns full-color EL displays*

Info Page 10
(how to find us)

Index of Advertisers .. 184

Reader Service Card 184A-D

ELECTRONIC DESIGN (ISSN 0013-4872) is published twice monthly except for 3 issues in May, 3 issues in August, 3 issues in October, and 3 issues in November by Penton Publishing Inc., 1100 Superior Ave., Cleveland, OH 44114-2543. Paid rates for a one-year subscription are as follows: \$105 U.S., \$185 Canada, \$210, \$255 International. Periodicals postage paid at Cleveland, OH, and additional mailing offices. Editorial and advertising addresses: ELECTRONIC DESIGN, 611 Route #46 West, Hoboken Heights, NJ 07464. Telephone (201) 393-6060. Facsimile (201)

Copyright 1997 by Penton Publishing Inc. All rights reserved. The contents of this publication may not be reproduced in whole or in part without the consent of the copyright owner. For subscriber change of address and subscription inquiries, call (216) 696-7000. Mail your subscription requests to: Penton Publishing Subscription Lockbox, P.O. Box 96732, Chicago, IL 60693. POSTMASTER: Please send change of address to ELECTRONIC DESIGN, Penton Publishing Inc., 1100 Superior Ave., Cleveland, OH 44114-2543.

COMMUNICATIONS TECHNOLOGY

Highlights and insights from the frontline of the communications revolution

MCNS/DOCSIS MAC Clears A Path For The Cable-Modem Invasion

The First Standards-Compliant Chip Means Affordable, Interoperable, Cable Modems, With Speed And Security Features.

Lee Goldberg

With the introduction of the BCM3220 multimedia cable networking systems/Data-Over-Cable-Service Interface Specification (MCNS/DOCSIS) compliant media-access controller (MAC) chip, the cable data revolution has begun in earnest. By rolling out the first integrated implementation of the cable industry's recently developed DOCSIS, Broadcom Corporation has paved the way for the rapid development of inexpensive consumer-oriented cable data appliances. This move could provide a critical jump-start for the emerging cable data industry. If the next year goes according to plan, we may see a device that delivers multimegabit downstream Internet access being sold at K-Mart's and electronic discount stores at prices comparable to today's 56-kbit POTS modems.

The Broadband Wars

The development of DOCSIS and the introduction of the BCM3220 mark the first hopeful chapter in the troubled history of cable media's efforts to maintain its dominant role in capturing the hearts, minds, and eyes of the American consumer. In the early nineties, the cable television industry faced a double threat: While saturated subscriber markets yielded flattening revenues, satellite television, sophisticated

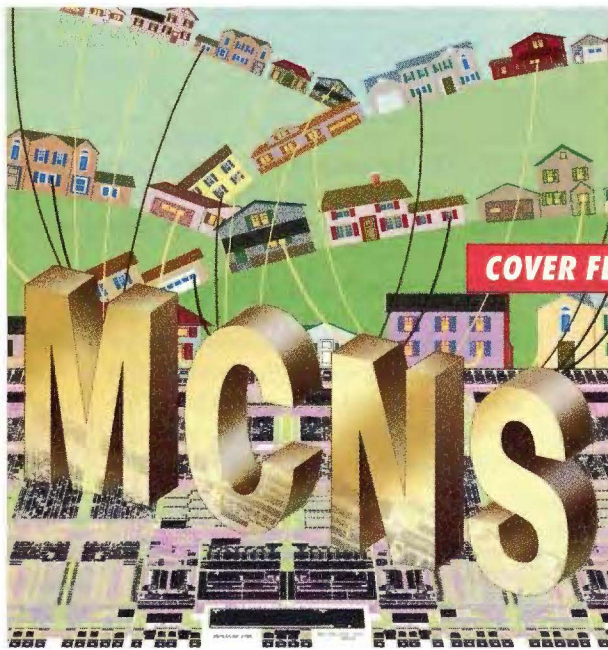

surfing began to erode cable's near-lock on passive leisure activities.

After several ill-fated adventures with video-on-demand, interactive shopping, and other attempts to dictate consumer taste, cable marketers stumbled over the obvious hot application, broadband Internet access. Once early trials demonstrated the economic potential, it became clear that the only way to achieve a critical mass of users was to develop a transmission standard that would enable the production of mass-produced, inexpensive, interoperable cable modems and set-top boxes (Fig. 1).

the IEEE's 802.14 cable data standards committee, a group of large cable interests formed the MCNS group. Comprised of heavyweights like Comcast and Time-Warner, MCNS teamed with the cable industry's research consortium, Cable Labs, Louisville, Colo., to produce their own open standard for moving data between cable network headends and subscriber's homes.

Enter DOCSIS

The first fruit of this alliance is the DOCSIS specification, developed by a group of manufacturers, under the direction of MCNS and Cable Labs. Participants in the initial development of DOCSIS included General Instruments, LAN City (now a part of Bay Networks), and Broadcom. This spec outlines the physical layer interfaces, MAC and transport protocols, security provisions, and other specifications necessary for designing interoperable cable data components. Subsequent fine-tuning was performed in an open forum hosted by Cable Labs and attended by most major players in the cable industry. The result is a standard that meets the needs of current users and anticipates the demands of future applications.

DOCSIS is designed to employ one or more unused video channels within

spectrum to transmit IP-based data across hybrid fiber coaxial networks. Complex phase/amplitude modulation enables each 6-MHz downstream channel to bring data into subscribers' homes at up to 38 Mbits/s. Depending on the bit rate selected by the operator, the shared downstream channel uses either 64- or 256-point quadrature-amplitude modulation (QAM). While little is known about what actual bandwidth requirements will be, initial results from field trials suggests that a single channel will provide groups of 200 to 1000 subscribers with Internet access that is substantially faster than today's best POTS-based services.

For communication from the home to headend, DOCSIS uses the 5-to-40-MHz sub-split band as a return path. Using QPSK today, or 16-QAM in subsequent versions, the upstream channel has a theoretical maximum throughput of 10 Mbits/s (see "Broadband To The Home: Challenges On the Last Mile," *Electronic Design*, Oct. 2, 1995, pp 67-83).

Since DOCSIS also is intended to support IP-based video, provisions have been made to support several levels of quality of service (QoS). This

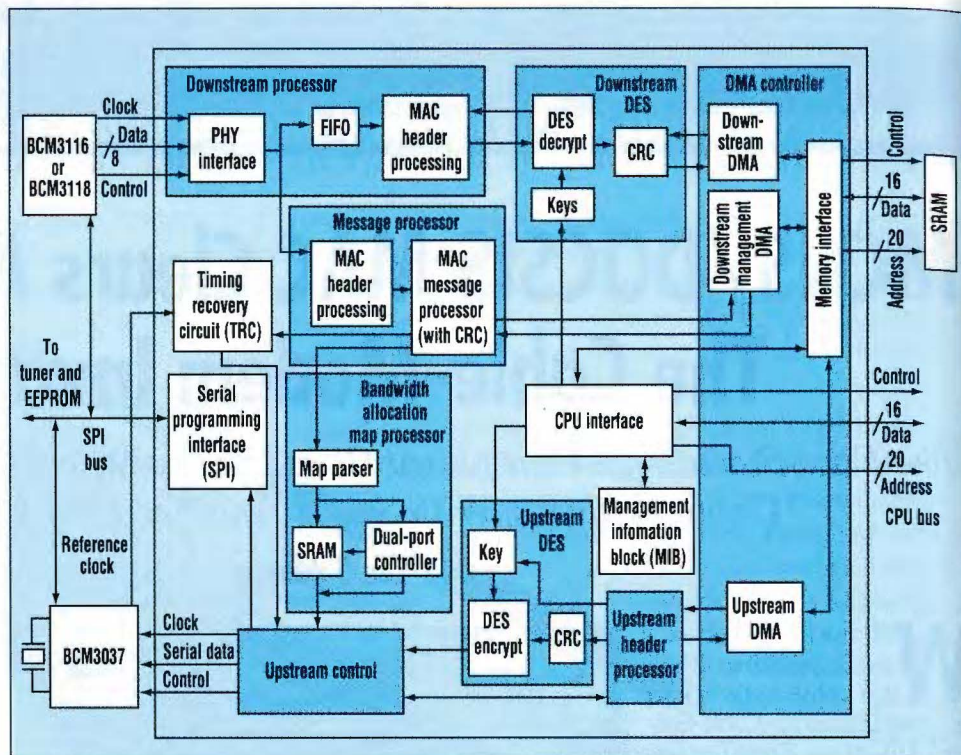

2. The BCM3220 MAC chip incorporates all control, stream-processing, and security functions required for a MCNS/DOCSIS-compliant cable modem. A memory-based DMA interface assures efficient data transfers to and from the host controller. Both baseline and high-security modes also are supported.

feature allows it to accommodate both traditional connectionless Internet traffic, as well as latency-sensitive multimedia streams. Selectable QoS also will let cable companies offer tiered services with various guaranteed bit rates and levels of latency to

businesses which need them.

MPEG Everywhere

One interesting aspect of DOCSIS is that it uses MPEG II transport streams to move IP data. While not essential for today's applications, the standard's developers were looking toward the future. Today, MPEG encapsulation provides DOCSIS with a reliable, well-defined method of setting up multiple channels within a single data stream. In the near future, MPEG encapsulation will allow a single cable modem to support multiple sessions and multiple users, as well as delay-sensitive multimedia streams for voice or video over IP.

Using MPEG II transport streams also will allow DOCSIS to interoperate with the Open Cable standard for digital cable television that is currently under development. Open Cable also employs MPEG II transport streams for all of its media flows. This feature should greatly simplify traffic switching and processing within tomorrow's cable networks

Although it has some similarities to the carrier-sense multiple-access/collision detect (CSMA/CD) protocol em-

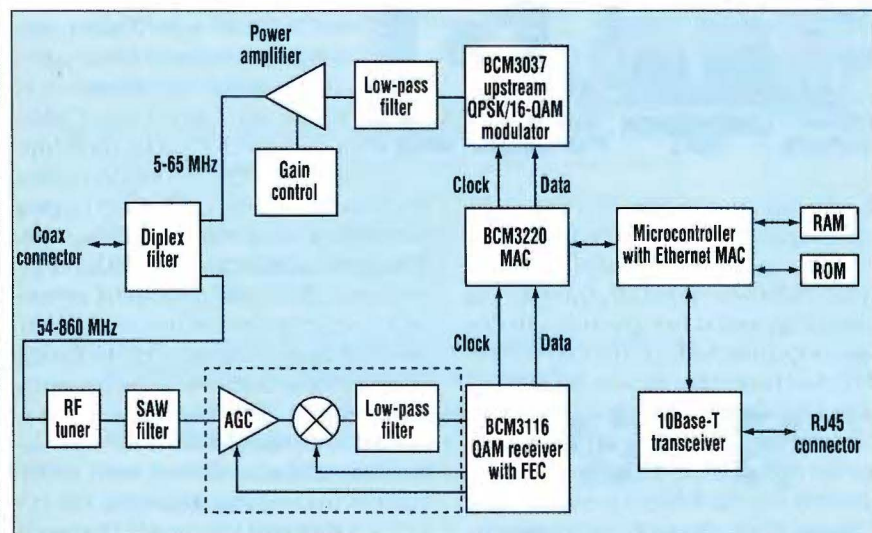

1. A DOCSIS-compliant cable modem receives its data over unused 6-MHz video channels within the normal cable spectrum. Upstream traffic is carried back to the system headend in the 5-to-45-MHz sub-split band. To ensure that the modem will operate properly and not interfere with other units, both the downstream receiver and upstream modulator/transmitter operate under the control of the BCM3220 or other DOCSIS-compatible MAC

CTRONIC DESIGN / DECEMBER 1, 1997

Explore Litigation Insights

Docket Alarm provides insights to develop a more informed litigation strategy and the peace of mind of knowing you're on top of things.

Real-Time Litigation Alerts



Keep your litigation team up-to-date with **real-time alerts** and advanced team management tools built for the enterprise, all while greatly reducing PACER spend.

Our comprehensive service means we can handle Federal, State, and Administrative courts across the country.

Advanced Docket Research



With over 230 million records, Docket Alarm's cloud-native docket research platform finds what other services can't. Coverage includes Federal, State, plus PTAB, TTAB, ITC and NLRB decisions, all in one place.

Identify arguments that have been successful in the past with full text, pinpoint searching. Link to case law cited within any court document via Fastcase.

Analytics At Your Fingertips



Learn what happened the last time a particular judge, opposing counsel or company faced cases similar to yours.

Advanced out-of-the-box PTAB and TTAB analytics are always at your fingertips.

API

Docket Alarm offers a powerful API (application programming interface) to developers that want to integrate case filings into their apps.

LAW FIRMS

Build custom dashboards for your attorneys and clients with live data direct from the court.

Automate many repetitive legal tasks like conflict checks, document management, and marketing.

FINANCIAL INSTITUTIONS

Litigation and bankruptcy checks for companies and debtors.

E-DISCOVERY AND LEGAL VENDORS

Sync your system to PACER to automate legal marketing.