

registration/alignment of subscans, two subscans of the same surface may incorrectly look like two different surfaces.

The near threshold distance may be such as 0.01 mm, 0.05 mm, 0.09 mm, 0.10 mm, 0.15 mm, 0.20 mm etc.

5

In some embodiments a far threshold distance is defined, which determines a distance from the captured surface, where the volume outside the far threshold distance is not included in the excluded volume of a representation.

10 Thus the volume outside the far threshold distance is not included in the first excluded volume of the first 3D representation, and the volume outside the far threshold distance is not included in the second excluded volume of the second 3D representation.

15 According to this embodiment any acquired data or surface or surface points of the first or second representation, which is/are present or located outside the far threshold distance, is not used to determine or define the first or second excluded volume, respectively.

20 It is an advantage because a surface or surface points from a movable object or from another part of the tooth surface can actually be present outside the far threshold distance without being detected by the scanner, due to the geometry and optical properties of the scanner. The light rays from the scanner head may be transmitted in any directions and with any angle or  
25 inclination from a normal plane of the scanner head, and therefore a light ray can be transmitted from the scanner head to a point which is placed behind the movable object or the other part of the tooth surface, when the movable object or the other part of the tooth surface is present partly in front of the scanner head.

30

Thus the volume outside the far threshold distance is not included in the excluded volume, because in the volume outside the far threshold distance a surface can be present even though no surface is detected by the scanner.

- 5 The far threshold distance defines or determines a distance from the captured surface, where the volume or region within the far threshold distance is included in the excluded volume.

Thus if utilizing or applying the far threshold distance, the excluded volume  
10 for a representation will be smaller than if not applying the far threshold distance, and therefore less volume can be excluded.

However, the advantage of applying a far threshold distance is that only volumes which can truly be excluded, will be excluded, meaning that the general scan data will have a higher quality.

15

Thus even though no surface or surface points has/have been detected in a volume or region between the scanner and the tooth surface, the whole region cannot be defined as excluded volume, because the light rays from and to the scanner may travel with inclined angles relative to a normal of the  
20 scan head, which means that the scanner can detect a point on the tooth surface even though another part of the tooth is actually placed, at least partly, between the detected tooth surface and the scanner. Therefore a far threshold distance is defined, and no data detected outside this far threshold distance from the tooth surface is used to define the excluded volume of a  
25 representation. Only data detected inside the far threshold distance is used to define the excluded volume, because only within this distance can one be certain that the data detected actually corresponds to the real physical situation.

- 30 The scanner may detect that no surface is present in the volume or region outside the far threshold distance between the tooth surface and the scanner,

but this data or information cannot be used to define the excluded volume of the representation, because there may actually be a movable object or another part of the tooth surface in this region or volume which the scanner overlooks because of its inclined light rays.

5

Furthermore, the scanner may overlook a surface part even though the surface part is in the scan volume. This can be caused by that the surface part is outside the focus region of the scanner, for example if the surface part is too close to the opening of the scanner head and/or scanner body, as the  
10 focus region may begin some distance from the scanner head and/or scanner body. Alternatively and/or additionally this can be caused by the lighting conditions, which may not be optimal for the given material of the surface, whereby the surface is not properly illuminated and thus can become invisible for the scanner. Thus in any case the scanner may overlook  
15 or look through the surface part. Hereby a volume in space may erroneously be excluded, since the scanner detects that no surface is present, and therefore a surface portion captured in this excluded volume in another 3D representation or scan would be disregarded. For avoiding that this happens, which would be unfavorably if the surface part was a true tooth surface, the  
20 far threshold distance can be defined, such that the excluded volume becomes smaller, such that only volume which really can be excluded is excluded.

It is an advantage that real surface points of a tooth are not erroneously disregarded, whereby fewer holes, i.e. regions with no scan data, are created  
25 in the scans. Thus the excluded volume is reduced by means of the far threshold distance for avoiding that too much surface information is incorrectly disregarded.

The light rays from the scan head of the scanner may spread or scatter or  
30 disperse in any directions.

Even if an object, such as a movable object, is arranged between the scan head and the surface of a rigid object, e.g. a tooth, the scanner may still capture a surface point on the tooth surface which is present or hidden “under” the object, because of the angled or inclined light rays. A surface point or area may just have to be visible for one or a small number of light rays from and/or to the scanner in order for that surface point or area to be detected.

Since the far threshold distance determines a distance from the captured surface in a representation, where any acquired data or surface or surface points, which is/are present or located outside the far threshold distance, is not used to define the excluded volume of the representation, any acquired data or surface or surface points in the volume between the far threshold distance and the scan head is not included in the definition of the excluded volume.

The actual distance of the far threshold may depend or be calculated based on the optics of the scanner. The far threshold distance may be a fixed number, such as about 0.5 mm, 1 mm, 2 mm, 3 mm, 4 mm, 5 mm, 6 mm, 7 mm, 8 mm, 9 mm, 10 mm, 20 mm, 30 mm, 40 mm, 50 mm, 60 mm, 70 mm, 80 mm, 90 mm, or 100 mm. Alternatively, the far threshold distance may be a percentage or a fraction of the length of the scan volume, such as about 20%, 25%, 30%, 35%, 40%, 45%, or 50% of the length of the scan volume, or such as  $\frac{1}{2}$ ,  $\frac{1}{3}$ ,  $\frac{1}{4}$ ,  $\frac{1}{5}$  of the length of the scan volume.

The far threshold distance may be based on a determination of how far a distance from a detected point of the surface it is possible to scan, i.e. how much of the surface around a detected point that is visible for the scanner. If the visible distance in one direction from a surface point is short, then the far threshold distance will be smaller than if the distance in all directions from a surface point is long.

In some embodiments the first representation of at least part of a surface is a first subscan of at least part of the location, and the second representation of

at least part of the surface is a second subscan of at least part of the location.

5 In some embodiments the first representation of at least part of a surface is a provisional virtual 3D model comprising the subscans of the location acquired already, and the second representation of at least part of the surface is a second subscan of at least part of the location.

10 In some embodiments acquired subscans of the location are adapted to be added to the provisional virtual 3D model concurrently with the acquisition of the subscans.

15 In some embodiments the provisional virtual 3D model is termed as the virtual 3D model, when the scanning of the rigid object is finished.

In some embodiments the method comprises:

- providing a third 3D representation of at least part of a surface by scanning at least part of the location;
- determine for the third 3D representation a third excluded volume in space  
20 where no surface can be present;
- if a portion of the surface in the first 3D representation is located in space in the third excluded volume, the portion of the surface in the first 3D representation is disregarded in the generation of the virtual 3D model, and/or
- 25 - if a portion of the surface in the second 3D representation is located in space in the third excluded volume, the portion of the surface in the second 3D representation is disregarded in the generation of the virtual 3D model, and/or
- 30 - if a portion of the surface in the third 3D representation is located in space in the first excluded volume and/or in the second excluded volume, the

portion of the surface in the third 3D representation is disregarded in the generation of the virtual 3D model.

5 In some embodiments the provisional virtual 3D model comprises the first representation of at least part of the surface and the second representation of at least part of the surface, and where the third representation of at least part of the surface is added to the provisional virtual 3D model.

10 Thus the timewise first acquired representation, which is not necessarily the first representation, and the timewise second acquired representation, which is not necessarily the second representation, may be combined to create the provisional virtual 3D model, and each time a new representation is acquired or provided, the new representation may be added to the provisional virtual 3D model, whereby the provisional virtual 3D model grows for each added representation.

15

In some embodiments the virtual 3D model is used for virtually designing a restoration for one or more of the patient's teeth.

20 Thus the purpose of scanning is to obtain a virtual 3D model of the patient's teeth. If the patient should have a restoration, e.g. a crown, a bridge, a denture, a partial removable etc., the restoration can be digitally or virtually designed on or relative to the 3D virtual model.

25 In some embodiments the virtual 3D model is used for virtually planning and designing an orthodontic treatment for the patient.

In some embodiments the relative motion of the scanner and the rigid object is determined.

30 In some embodiments the relative motion of the scanner and the rigid object is determined by means of motion sensors.

If the scanner used for acquiring the sub-scans is a handheld scanner, then the relative position, orientation or motion of scanner and the object which is scanned must be known. The relative position, orientation and motion of the scanner can be determined by means of position, orientation and/or motion  
5 sensors. However, if these sensors are not accurate enough for the purpose, the precise relative position of scanner and object can be determined by comparing the obtained 3D surfaces in the sub-scans, such as by means of alignment/registration.

A motion sensor is a device that can perform motion measurement, such as  
10 an accelerometer. Furthermore the motion sensor may be defined as a device which works as a position and orientation sensor as well.

A position sensor is a device that permits position measurement. It can be an absolute position sensor or a relative position sensor, also denoted displacement sensor. Position sensors can be linear or angular.

15 An orientation sensor is a device that can perform orientation measurement, such as a gyroscope.

In some embodiments the relative motion of the scanner and the rigid object is determined by registering/aligning the first representation and the second  
20 representation.

In some embodiments the first representation and the second representation are aligned/registered before the first excluded volume and the second excluded volume are determined.

25 Thus after the first and the second representation are provided, they may be aligned/registered, and after this, the first and second excluded volume may be determined, and then it is detected whether a portion of the surface in the first 3D representation or in the second 3D representation is located in space in the second excluded volume or in the first excluded volume, respectively,  
30 such that such portion of the surface in the representation is disregarded in the generation of the virtual 3D model.

Alignment or registration may comprise bringing the 3D representations or subscans together in a common reference system, and then merging them to create the virtual 3D model or a provisional virtual 3D model. For each  
5 representation or subscan which is aligned/registered to the provisional virtual 3D model, the model grows and finally it becomes the virtual 3D model of the object.

In some embodiments the relative motion of the scanner and the rigid object  
10 determined by means of the motions sensors is verified and potentially adjusted by registering/aligning the first representation and the second representation.

In some embodiments motion sensors are used for an initial determination of  
15 the relative motion of the scanner and the rigid object, and where registering/aligning is used for the final determination of the relative motion of the scanner and the rigid object.

Thus in practice the motion sensors may be used as a first guess for the motion, and based on this the alignment/registration may be used for testing  
20 the determined motion and/or determining the precise motion or adjusting the determined motion.

In some embodiments the optical system of the scanner is telecentric.  
A telecentric system is an optical system that provides imaging in such a way  
25 that the chief rays are parallel to the optical axis of said optical system. In a telecentric system out-of-focus points have substantially same magnification as in-focus points. This may provide an advantage in the data processing. A perfectly telecentric optical system may be difficult to achieve, however an optical system which is substantially telecentric or near telecentric may be  
30 provided by careful optical design. Thus, when referring to a telecentric optical system it is to be understood that it may be only near telecentric.



As the chief rays in a telecentric optical system are parallel to the optical axis, the scan volume becomes rectangular or cylindrical.

In some embodiments the optical system of the scanner is perspective.

- 5 If the optical system is a perspective system, the chief rays are angled relative to the optical axis, and the scan volume thus becomes cone shaped. Note that the scan volume is typically a 3D shape.

- 10 In some embodiments a mirror in a scan head of the scanner provides that the light rays from the light source in the scanner are transmitted with an angle relative to the opening of the scan head.

The scan volume may be defined not as rectangular but rather as resembling a parallelogram.

- 15 The light reflected back from a point on the surface may be projected as rays forming a cone or as parallel rays.

In some embodiments the 3D scanner is a hand-held scanner.

The 3D scanner may for example be a hand-held intraoral scanner.

20

In some embodiments the scanner is a pinhole scanner.

- A pinhole scanner comprises a pinhole camera having a single small aperture. The size of the aperture may be such as 1/100 or less of the distance between it and the projected image. Furthermore, the pinhole size  
25 may be determined by the formula  $d=2\sqrt{(2f\lambda)}$ , where  $d$  is pinhole diameter,  $f$  is focal length, i.e. the distance from pinhole to image plane, and  $\lambda$  is the wavelength of light.

- 30 It is an advantage to use the present method for detecting a movable object in a location in a pinhole scanner, since determining the first excluded volume and the second excluded volume is very fast, easy and accurate due to the pinhole setup, where the camera and the light source/projected

pattern, respectively, of the scanner are well-defined points in space relative to the captured surface.

Furthermore, if the scanner is a pinhole scanner, the excluded volume may  
5 be bigger, compared to if the scanner is not a pinhole scanner. The reason  
for this is because no far threshold distance can or should be defined when  
using a pinhole scanner, since no volume between the scanner and the  
captured tooth surface may not be included in the excluded volume due to  
the geometry and optical properties of the scanner. The pinhole scanner  
10 cannot overlook a surface or surface points from e.g. a movable object due to  
its geometry and optical properties.

In some embodiments the scanner comprises an aperture, and the size of  
the aperture is less than  $1/100$  of the distance between it and the projected  
15 image.

This size of aperture corresponds to a pinhole scanner.

In some embodiments the scanner comprises an aperture, and the size of  
the aperture is more than  $1/100$  of the distance between it and the projected  
20 image.

This size of aperture corresponds to a scanner which is not a pinhole  
scanner.

## 25 *Further aspects*

According to another aspect of the invention, disclosed is a method for  
detecting movable objects in the mouth of a patient, when scanning the  
patient's set of teeth in the mouth by means of a 3D scanner for generating a  
30 virtual 3D model of the set of teeth, wherein the method comprises:

- providing a first 3D representation of at least part of a surface by scanning at least part of the teeth;
- providing a second 3D representation of at least part of the surface by scanning at least part of the teeth;
- 5 - determining for the first 3D representation a first excluded volume in space where no surface can be present;
- determining for the second 3D representation a second excluded volume in space where no surface can be present;
- if a portion of the surface in the first 3D representation is located in space in  
10 the second excluded volume, the portion of the surface in the first 3D representation is disregarded in the generation of the virtual 3D model, and/or
- if a portion of the surface in the second 3D representation is located in space in the first excluded volume, the portion of the surface in the second  
15 3D representation is disregarded in the generation of the virtual 3D model.

According to another aspect of the invention, disclosed is a method for detecting a movable object in a location, when scanning a rigid object in the location by means of a 3D scanner for generating a virtual 3D model of the  
20 rigid object, wherein the method comprises:

- providing a first representation of at least part of a surface by scanning the rigid object;
- determining a first scan volume in space related to the first representation of  
25 at least part of the surface;
- providing a second representation of at least part of the surface by scanning the rigid object;
- determining a second scan volume in space related to the second representation of at least part of the surface;
- 30 - if there is a common scan volume, where the first scan volume and the second scan volume are overlapping, then:

- determine whether there is a volume region in the common scan volume which in at least one of the first representation or the second representation is empty and comprises no surface; and
- 5
- if there is a volume region in the common scan volume which in at least one of the first representation or the second representation is empty and comprises no surface, then exclude the volume region by disregarding in the generation of the virtual 3D model any surface portion in the second representation or in
- 10
- the first representation, respectively, which is detected in the excluded volume region, since a surface portion detected in the excluded volume region represents a movable object which is not part of the rigid object.
- 15
- According to another aspect of the invention, disclosed is a method for detecting a movable object in a location, when scanning a rigid object in the location by means of a 3D scanner for generating a virtual 3D model of the rigid object, wherein the method comprises:
- 20
- providing a first surface by scanning the rigid object;
  - determining a first scan volume related to the first surface;
  - providing a second surface by scanning the rigid object;
  - determining a second scan volume related to the second surface;
- where the first scan volume and the second scan volume are overlapping in
- 25
- an overlapping/common scan volume;
  - if at least a portion of the first surface and a portion of the second surface are not coincident in the overlapping/common scan volume, then disregard the portion of either the first surface or the second surface in the overlapping/common scan volume which is closest to the focusing optics of
- 30
- the 3D scanner, as this portion of the first surface or second surface represents a movable object which is not part of the rigid object.

According to another aspect of the invention, disclosed is a method for detecting a movable object in the mouth of the patient, when scanning the patient's set of teeth by means of a 3D scanner for generating a virtual 3D model of the set of teeth, wherein the method comprises:

- providing a first surface by scanning the set of teeth;
  - determining a first scan volume related to the first surface;
  - providing a second surface by scanning the set of teeth;
  - 10 - determining a second scan volume related to the second surface;
- where the first scan volume and the second scan volume are overlapping in an overlapping/common scan volume;
- if at least a portion of the first surface and a portion of the second surface are not coincident in the overlapping/common scan volume, then disregard
  - 15 the portion of either the first surface or the second surface in the overlapping/common scan volume which is closest to the focusing optics of the 3D scanner, as this portion of the first surface or second surface represents a movable object which is not part of the set of teeth.

20 According to another aspect of the invention, disclosed is a method for detecting movable objects recorded in subscans, when scanning a set of teeth by means of a scanner for generating a virtual 3D model of the set of teeth, where the virtual 3D model is made up of the already acquired subscans of the surface of the set of teeth, and where new subscans are

25 adapted to be added to the 3D virtual model, when they are acquired, wherein the method comprises:

- acquiring at least a first subscan of at least a first surface of part of the set of teeth, where the at least first subscan is defined as the 3D virtual model;
- 30 - acquiring a first subscan of a first surface of part of the set of teeth;
- determining a first scan volume of the first subscan;

- determining a scan volume of the virtual 3D model;
- if the first scan volume of the first subscan and the scan volume of the virtual 3D model are at least partly overlapping in a common scan volume; then:
  - 5                   - calculate whether at least a portion of the first surface lies within the common scan volume;
  - calculate whether at least a portion of the surface of the virtual 3D model lies within the common scan volume, and
  - determine whether at least a portion of a surface is present in
  - 10                   the overlapping volume only in one subscan and not the other subscan/3D virtual model;
  - if at least a portion of a surface is present in only one subscan, then disregard the portion of the surface in the overlapping volume which is closest to the focusing optics of the scanner,
  - 15                   since the portion of the surface represents a movable object which is not part of the set of teeth, and the portion of the surface is disregarded in the creation of the virtual 3D model of the set of teeth.
  
- 20   According to another aspect of the invention, disclosed is a method for detecting movable objects recorded in subsamples, when scanning a set of teeth by means of a scanner for generating a virtual 3D model of the set of teeth, wherein the method comprises:
  - 25   a) providing a first subscan of a first surface of part of the set of teeth;
  - b) calculating a first scan volume of the first subscan;
  - c) providing a second subscan of a second surface of part of the set of teeth;
  - d) calculating a second scan volume of the second subscan; and
  - e) if the first scan volume and the second scan volume are at least partly
  - 30   overlapping in a common scan volume; then:

- f) calculate whether at least a portion of the first surface lies within the common scan volume;
- g) calculate whether at least a portion of the second surface lies within the common scan volume, and
- 5 h) if at least a portion of the first surface or at least a portion of the second surface lie within the common scan volume, and the portion of the first surface or the portion of the second surface is located in space between the scanner and at least a portion of the second surface or at least a portion of the first surface,
- 10 respectively;
- then the portion of the surface represents a movable object which is not part of the set of teeth, and the portion of the surface is disregarded in the creation of the virtual 3D model of the set of teeth.

15

In some embodiments the method above further comprises:

- providing a third subscan of a third surface of part of the set of teeth;
  - calculating a third scan volume of the third subscan;
  - if the third scan volume is at least partly overlapping with the first scan
- 20 volume and/or with the second scan volume in a common scan volume; then repeat steps f) - h) for the third subscan with respect to the first subscan and/or the second subscan.

Further embodiments are disclosed in the following sections:

25

*Focus scanning and motion determination*

In some embodiments the 3D scanning comprises the steps of:

- generating a probe light,
- 30 - transmitting the probe light towards the object thereby illuminating at least a part of the object,

25

- transmitting light returned from the object to a camera comprising an array of sensor elements,
- imaging on the camera at least part of the transmitted light returned from the object to the camera by means of an optical system,
- 5 - varying the position of the focus plane on the object by means of focusing optics,
- obtaining at least one image from said array of sensor elements,
- determining the in-focus position(s) of:
  - each of a plurality of the sensor elements for a
  - 10 sequence of focus plane positions, or
  - each of a plurality of groups of the sensor elements for a sequence of focus plane positions.

There may be for example more than 200 focus plane images, such as 225  
15 focus plane images, in a sequence of focus plane images used in generating a 3D surface. The focus plane images are 2D images.

Image sensor(s), photo sensor and the like can be used for acquiring images in the scanner. By scanning is generally meant optical scanning or imaging  
20 using laser light, white light etc.

In some embodiments a sequence of focus plane images are depth images captured along the direction of the optical axis.

25 In some embodiments at least a part of the object is in focus in at least one of the focus plane images in a sequence of focus plane images.

In some embodiments the time period between acquisition of each focus plane image is fixed/predetermined/known.

30



Each focus plane image may be acquired a certain time period after the previous focus plane image was acquired. The focus optics may move between the acquisition of each image, and thus each focus plane image may be acquired in a different distance from the object than the previous focus plane images.

One cycle of focus plane image capture may be from when the focus optics is in position P until the focus optics is again in position P. This cycle may be denoted a sweep. There may such as 15 sweeps per second.

A number of 3D surfaces or sub-scans may then be combined to create a full scan of the object for generating a 3D model of the object.

In some embodiments determining the relative motion of the scanner during the acquisition of the sequence of focus plane images is performed by analysis of the sequence in itself.

*Motion detection by means of hardware*

In some embodiments determining the relative motion of the scanner during the acquisition of the sequence of focus plane images is performed by sensors in and/or on the scanner and/or by sensors on the object and/or by sensors in the room where the scanner and the object are located.

The motion sensors may be small sensor such as microelectromechanical systems (MEMS) motion sensors. The motion sensors may measure all motion in 3D, i.e., both translations and rotations for the three principal coordinate axes. The benefits are:

- Motion sensors can detect motion, also vibrations and/or shaking. Scans such affected can e.g. be corrected by use of the compensation techniques described.

5 - Motion sensors can help with stitching and/or registering partial scans to each other. This advantage is relevant when the field of view of the scanner is smaller than the object to be scanned. In this situation, the scanner is applied for small regions of the object (one at a time) that then are combined to obtain the full scan. In the ideal case, motion sensors can provide the  
10 required relative rigid-motion transformation between partial scans' local coordinates, because they measure the relative position of the scanning device in each partial scan. Motion sensors with limited accuracy can still provide a first guess for a software-based stitching/ registration of partial scans based on, e.g., the Iterative Closest Point class of algorithms, resulting  
15 in reduced computation time.

Even if it is too inaccurate to sense translational motion, a 3-axis accelerometer can provide the direction of gravity relative to the scanning device. Also a magnetometer can provide directional information relative to the scanning device, in this case from the earth's magnetic field. Therefore,  
20 such devices can help with stitching/registration.

In some embodiments the motion is determined by means of a texture image sensor having a depth of focus which is larger than the depth of focus of the focusing optics.

25

In some embodiments the motion is determined by determining the position and orientation of one or more of the sensors.

In some embodiments the motion is determined by means of one or more  
30 physical components arranged in the handheld scanner.

In some embodiments the motion is determined by means of 3D position sensors.

In some embodiments the motion is determined by means of optical tracking.

- 5 The optical tracking may comprise LED(s) and camera(s), where the LED(s) may flash and the flashing can be detected by the camera(s).

In some embodiments the motion is determined by means of one or more gyroscopes.

- 10 A gyroscope is a device for measuring or maintaining orientation, based on the principles of conservation of angular momentum. A mechanical gyroscope is essentially a spinning wheel or disk whose axle is free to take any orientation. The gyroscopes used to determine the orientation of the sensor may be mechanical gyroscopes, electronic, microchip-packaged  
15 MEMS gyroscope devices, solid state ring lasers, fibre optic gyroscopes, quantum gyroscope and/or the like.

In some embodiments the motion is determined by means of one or more accelerometers.

20

In some embodiments the motion is determined by means of one or more magnetometers.

In some embodiments the motion is determined by means of one or more  
25 electromagnetic coils.

In some embodiments the motion is determined by means of a computerized measurement arm.

- 30 The measurement arm may for instance be from FARO Technologies. There may be goniometers in the measurement arm for measuring the movements of the arm.

In some embodiments the motion is determined by means of one or more axes on which the sensor is configured to move.

An example of an axes based system is a coordinate measuring machine (CMM), which is a device for measuring the physical geometrical characteristics of an object. This machine may be computer controlled. A typical CMM is composed of three axes, X, Y and Z, and these axes are orthogonal to each other in a typical three dimensional coordinate system. Each axis has a scale system that indicates the location of that axis. Measurements may be defined by a probe attached to the third moving axis of this machine, and the machine will read the input from the touch probe. Probes may be mechanical, optical, laser, or white light, among others.

In some embodiments the axes on which the sensor is configured to move are translational and / or rotational axes.

For each focus plane image that is acquired there is six degrees of freedom of the sensor, e.g. the handheld scanner, since the scanner is a rigid body which can perform motion in a three dimensional space, where the motion can be translation in three perpendicular axes, x, y, z, which is movement forward/backward, up/down, left/right, and this is combined with rotation about the three perpendicular axes. Thus the motion has six degrees of freedom as the movement along each of the three axes is independent of each other and independent of the rotation about any of these axes.

### *3D modeling*

3D modeling is the process of developing a mathematical, wireframe representation of any three-dimensional object, called a 3D model, via specialized software. Models may be created automatically, e.g. 3D models may be created using multiple approaches, such as use of NURBS curves to generate accurate and smooth surface patches, polygonal mesh modeling

which is a manipulation of faceted geometry, or polygonal mesh subdivision which is advanced tessellation of polygons, resulting in smooth surfaces similar to NURBS models.

Obtaining a three dimensional representation of the surface of an object by  
5 scanning the object in a 3D scanner can be denoted 3D modeling, which is the process of developing a mathematical representation of the three-dimensional surface of the object via specialized software. The product is called a 3D model. A 3D model represents the 3D object using a collection of  
10 points in 3D space, connected by various geometric entities such as triangles, lines, curved surfaces, etc. The purpose of a 3D scanner is usually to create a point cloud of geometric samples on the surface of the object.

3D scanners collect distance information about surfaces within its field of view. The “picture” produced by a 3D scanner may describe the distance to a surface at each point in the picture.

15 For most situations, a single a scan or sub-scan will not produce a complete model of the object. Multiple sub-scans, such as 5, 10, 12, 15, 20, 30, 40, 50, 60, 70, 80, 90 or in some cases even hundreds, from many different directions may be required to obtain information about all sides of the object. These sub-scans are brought in a common reference system, a process that  
20 may be called alignment or registration, and then merged to create a complete model.

3D scanners may be fixed or stationary desktop scanners into which for example a dental impression, an ear canal impression or a casted gypsum model of teeth can be placed for scanning. 3D scanners may also be  
25 handheld intraoral scanners for scanning a patient directly in the mouth or handheld or fixed ear scanners for scanning a patient directly in the ear.

Thus a 3D scanner may be a handheld scanner where scanner and object are not arranged stationary relative to each other and where the relative motion may be unlimited, a desktop scanner where the object and the

scanning means, e.g. light source and camera, are arranged stationary relative to each other, a stationary scanner where the object for example can move relative to the stationary scanner etc.

5 A triangulation 3D laser scanner uses laser light to probe the environment or object. A triangulation laser shines a laser on the object and exploits a camera to look for the location of the laser dot. Depending on how far away the laser strikes a surface, the laser dot appears at different places in the camera's field of view. This technique is called triangulation because the laser dot, the camera and the laser emitter form a triangle. A laser stripe,  
10 instead of a single laser dot, may be used and is then swept across the object to speed up the acquisition process.

Structured-light 3D scanners project a pattern of light on the object and look at the deformation of the pattern on the object. The pattern may be one dimensional or two dimensional. An example of a one dimensional pattern is  
15 a line. The line is projected onto the object using e.g. an LCD projector or a sweeping laser. A camera, offset slightly from the pattern projector, looks at the shape of the line and uses a technique similar to triangulation to calculate the distance of every point on the line. In the case of a single-line pattern, the line is swept across the field of view to gather distance information one strip  
20 at a time.

An example of a two-dimensional pattern is a grid or a line stripe pattern. A camera is used to look at the deformation of the pattern, and an algorithm is used to calculate the distance at each point in the pattern. Algorithms for multistripe laser triangulation may be used.

25 Confocal scanning or focus scanning may also be used, where in-focus images are acquired at different depth to reconstruct the 3D model.

Iterative Closest Point (ICP) is an algorithm employed to minimize the difference between two clouds of points. ICP can be used to reconstruct 2D or 3D surfaces from different scans or sub-scans. The algorithm is

conceptually simple and is commonly used in real-time. It iteratively revises the transformation, i.e. translation and rotation, needed to minimize the distance between the points of two raw scans or sub-scans. The inputs are: points from two raw scans or sub-scans, initial estimation of the transformation, criteria for stopping the iteration. The output is: refined transformation. Essentially the algorithm steps are:

1. Associate points by the nearest neighbor criteria.
2. Estimate transformation parameters using a mean square cost function.
3. Transform the points using the estimated parameters.
- 10 4. Iterate, i.e. re-associate the points and so on.

#### *Aligning/registration*

In some embodiments the motion between at least two subsequent 3D surfaces are determined by aligning/registering the at least two subsequent 3D surfaces.

This may be performed by means of the method of iterative closest point (ICP) or similar methods. The method of Iterative Closest Point (ICP) can be used for aligning, and it is employed to minimize the difference between two clouds of points. ICP can be used to reconstruct 2D or 3D surfaces from different scan. ICP iteratively revises the transformation, i.e. translation or rotation, needed to minimize the distance between the points of two raw scans or subscans. The input for ICP may be points from two raw scans or subscans, initial estimation of the transformation, and criteria for stopping the iteration. The output will thus be a refined transformation.

The alignment may be performed in two steps, where the first step is a subscan to subscan alignment, and the second step is a subscan to provisional virtual 3D model (combined model) alignment. The start guess for

the alignment may be determined by using the gyroscopes, estimated speed of the scanner etc.

Additionally and/or alternatively, the method of least squares fit can be used in alignment.

5 In some embodiments aligning/registering is performed by selecting corresponding points on the at least two 3D surfaces, and minimizing the distance between the at least two 3D surfaces.

Corresponding points may be the closest points on two surfaces, or point determined by a normal vector from a point on the other surface etc

10 The distance may be minimized with regards to translation and rotation.

In some embodiments aligning/registration is continued in an iterative process to obtain an improved motion estimation.

15 In some embodiments the sensor position of each sequence is determined based on the alignment.

In some embodiments aligning comprises aligning the coordinate systems of at least two 3D surfaces.

20

In some embodiments aligning comprises aligning by means of matching / comparing one or more specific features, such as one or more specific features common to the at least two 3D surfaces, such as the margin line.

25 In some embodiments aligning comprises aligning by means of matching / comparing one or more peripheral features of the at least two 3D surfaces.

In some embodiments aligning comprises registration of the at least two 3D surfaces.

30



In some embodiments aligning comprises applying a predefined criterion for maximum allowed error in the registration.

5 In some embodiments the motion compensation comprises reconstructing a self-consistent surface model and motion and/or rotation of the scanner relative to the object from two or more scans of the object where two successive scans overlap at least partially.

*Focus scanning*

10

The 3D scanner may be used for providing a 3D surface registration of objects using light as a non-contact probing agent. The light may be provided in the form of an illumination pattern to provide a light oscillation on the object. The variation / oscillation in the pattern may be spatial, e.g. a static checkerboard pattern, and/or it may be time varying, for example by moving  
15 a pattern across the object being scanned. The invention provides for a variation of the focus plane of the pattern over a range of focus plane positions while maintaining a fixed spatial relation of the scanner and the object. It does not mean that the scan must be provided with a fixed spatial  
20 relation of the scanner and the object, but merely that the focus plane can be varied (scanned) with a fixed spatial relation of the scanner and the object. This provides for a hand held scanner solution based on the present invention.

25 In some embodiments the signals from the array of sensor elements are light intensity.

One embodiment of the invention comprises a first optical system, such as an arrangement of lenses, for transmitting the probe light towards the object  
30 and a second optical system for imaging light returned from the object to the camera. In the preferred embodiment of the invention only one optical system

images the pattern onto the object and images the object, or at least a part of the object, onto the camera, preferably along the same optical axis, however along opposite optical paths.

5 In the preferred embodiment of the invention an optical system provides an imaging of the pattern onto the object being probed and from the object being probed to the camera. Preferably, the focus plane is adjusted in such a way that the image of the pattern on the probed object is shifted along the optical axis, preferably in equal steps from one end of the scanning region to the  
10 other. The probe light incorporating the pattern provides a pattern of light and darkness on the object. Specifically, when the pattern is varied in time for a fixed focus plane then the in-focus regions on the object will display an oscillating pattern of light and darkness. The out-of-focus regions will display smaller or no contrast in the light oscillations.

15

Generally we consider the case where the light incident on the object is reflected diffusively and/or specularly from the object's surface. But it is understood that the scanning apparatus and method are not limited to this situation. They are also applicable to e.g. the situation where the incident  
20 light penetrates the surface and is reflected and/or scattered and/or gives rise to fluorescence and/or phosphorescence in the object. Inner surfaces in a sufficiently translucent object may also be illuminated by the illumination pattern and be imaged onto the camera. In this case a volumetric scanning is possible. Some planktic organisms are examples of such objects.

25

When a time varying pattern is applied a single sub-scan can be obtained by collecting a number of 2D images at different positions of the focus plane and at different instances of the pattern. As the focus plane coincides with the scan surface at a single pixel position, the pattern will be projected onto the  
30 surface point in-focus and with high contrast, thereby giving rise to a large variation, or amplitude, of the pixel value over time. For each pixel it is thus

possible to identify individual settings of the focusing plane for which each pixel will be in focus. By using knowledge of the optical system used, it is possible to transform the contrast information vs. position of the focus plane into 3D surface information, on an individual pixel basis.

5

Thus, in one embodiment of the invention the focus position is calculated by determining the light oscillation amplitude for each of a plurality of sensor elements for a range of focus planes.

10 For a static pattern a single sub-scan can be obtained by collecting a number of 2D images at different positions of the focus plane. As the focus plane coincides with the scan surface, the pattern will be projected onto the surface point in-focus and with high contrast. The high contrast gives rise to a large spatial variation of the static pattern on the surface of the object, thereby  
15 providing a large variation, or amplitude, of the pixel values over a group of adjacent pixels. For each group of pixels it is thus possible to identify individual settings of the focusing plane for which each group of pixels will be in focus. By using knowledge of the optical system used, it is possible to transform the contrast information vs. position of the focus plane into 3D  
20 surface information, on an individual pixel group basis.

Thus, in one embodiment of the invention the focus position is calculated by determining the light oscillation amplitude for each of a plurality of groups of the sensor elements for a range of focus planes.

25

The 2D to 3D conversion of the image data can be performed in a number of ways known in the art. I.e. the 3D surface structure of the probed object can be determined by finding the plane corresponding to the maximum light oscillation amplitude for each sensor element, or for each group of sensor  
30 elements, in the camera's sensor array when recording the light amplitude for a range of different focus planes. Preferably, the focus plane is adjusted in

equal steps from one end of the scanning region to the other. Preferably the focus plane can be moved in a range large enough to at least coincide with the surface of the object being scanned.

- 5 The scanner preferably comprises at least one beam splitter located in the optical path. For example, an image of the object may be formed in the camera by means of a beam splitter. Exemplary uses of beam splitters are illustrated in the figures.
- 10 In a preferred embodiment of the invention light is transmitted in an optical system comprising a lens system. This lens system may transmit the pattern towards the object and images light reflected from the object to the camera.

In a telecentric optical system, out-of-focus points have the same  
15 magnification as in-focus points. Telecentric projection can therefore significantly ease the data mapping of acquired 2D images to 3D images. Thus, in a preferred embodiment of the invention the optical system is substantially telecentric in the space of the probed object. The optical system may also be telecentric in the space of the pattern and camera.

20

The present invention relates to different aspects including the method described above and in the following, and corresponding methods, devices, apparatuses, systems, uses and/or product means, each yielding one or  
25 more of the benefits and advantages described in connection with the first mentioned aspect, and each having one or more embodiments corresponding to the embodiments described in connection with the first mentioned aspect and/or disclosed in the appended claims.

- 30 In particular, disclosed herein is a system for detecting a movable object in a location, when scanning a rigid object in the location by means of a 3D

scanner for generating a virtual 3D model of the rigid object, wherein the system comprises:

- 5 - means for providing a first 3D representation of at least part of a surface by scanning at least part of the location;
- means for providing a second 3D representation of at least part of the surface by scanning at least part of the location;
- means for determining for the first 3D representation a first excluded volume in space where no surface can be present;
- 10 - means for determining for the second 3D representation a second excluded volume in space where no surface can be present;
- means for disregarding the portion of the surface in the first 3D representation in the generation of the virtual 3D model, if a portion of the surface in the first 3D representation is located in space in the second
- 15 excluded volume, and/or
- means for disregarding the portion of the surface in the second 3D representation in the generation of the virtual 3D model, if a portion of the surface in the second 3D representation is located in space in the first
- 20 excluded volume.

20 Furthermore, the invention relates to a computer program product comprising program code means for causing a data processing system to perform the method according to any of the embodiments, when said program code means are executed on the data processing system, and a computer

25 program product, comprising a computer-readable medium having stored there on the program code means.

### **Brief description of the drawings**

30

The above and/or additional objects, features and advantages of the present invention, will be further elucidated by the following illustrative and non-limiting detailed description of embodiments of the present invention, with reference to the appended drawings, wherein:

5

Fig. 1 shows an example of a flowchart of the method for detecting a movable object in a location, when scanning a rigid object in the location by means of a 3D scanner for generating a virtual 3D model of the rigid object.

10  

Fig. 2 shows an example of a scan head of an intraoral 3D scanner scanning a set of teeth.

Fig. 3 shows an example of a handheld 3D scanner.

15  

Fig. 4 shows an example of a section of teeth in the mouth which can be covered in a sub-scan.

Fig. 5 shows an example of how the different sub-scans generating 3D surfaces are distributed across a set of teeth.

20

Fig. 6 shows an example of registering/aligning representations of 3D surfaces and compensating for motion in a 3D surface.

25  

Fig. 7 shows an example of a 3D surface where overlapping sub-scans are indicated.

Fig. 8 shows an example of excluded volume.

30  

Fig. 9 shows an example of scanning a tooth and acquiring a first and a second representation of the surface of the tooth, where no movable object is present.

Fig. 10 shows an example of scanning a tooth and acquiring a first and a second representation of the surface of the tooth, where a movable object is captured in part of the first representation.

5

Fig. 11 shows an example of scanning a tooth and acquiring a first and a second representation of the surface of the tooth, where a movable object is captured in the second representation.

10 Fig. 12 shows an example of acquiring a first and a second representation of the surface of an object, e.g. a tooth, where a movable object is captured in the first representation.

15 Fig. 13 shows an example of acquiring a first and a second representation of a surface of an object, where no movable object is present.

Fig. 14 shows an example of acquiring a first and a second representation of a surface of an object, where a movable object of the second representation is present in the excluded volume of the first representation.

20

Fig. 15 shows an example of acquiring a first and a second representation of a surface of an object, where a possible movable object is present in the second representation, but not in the excluded volume of the first representation.

25

Fig. 16 shows an example of a near threshold distance defining how far from the representation possible movable objects are disregarded in the generation of the virtual 3D model.

30 Fig. 17 shows an example of how the excluded volume is determined.

Fig. 18 shows examples of how movable objects can look in subscans.

Fig. 19 shows an example of a pinhole scanner.

- 5 Fig. 20 shows examples of the principle of a far threshold distance from the captured surface defining a volume which is not included in the excluded volume of a representation.

10 **Detailed description**

In the following description, reference is made to the accompanying figures, which show by way of illustration how the invention may be practiced.

- 15 Figure 1 shows an example of a flowchart of the method for detecting a movable object in a location, when scanning a rigid object in the location by means of a 3D scanner for generating a virtual 3D model of the rigid object. In step 101 a first 3D representation of at least part of a surface is provided by scanning at least part of the location.

- 20 In step 102 a second 3D representation of at least part of the surface is provided by scanning at least part of the location.

In step 103 a first excluded volume in space where no surface can be present is determined for the first 3D representation.

- In step 104 a second excluded volume in space where no surface can be present is determined for the second 3D representation.

- 25 In step 105 a portion of the surface in the first 3D representation is disregarded in the generation of the virtual 3D model, if the portion of the surface in the first 3D representation is located in space in the second excluded volume, and/or a portion of the surface in the second 3D  
30 representation is disregarded in the generation of the virtual 3D model, if the



portion of the surface in the second 3D representation is located in space in the first excluded volume.

Fig. 2 shows an example of a scan head of an intraoral 3D scanner scanning  
5 a set of teeth.

An intraoral handheld 3D scanner (not shown) comprising a scan head 207 is scanning a tooth 208. The scanning is performed by transmitting light rays on the tooth 208. The light rays forms a scan volume 211, which is cone shaped in this example.

10 The length 203 of the scan volume 211, i.e. the distance from the opening 202 of the scan head to the end of the scan volume may be for example about 5 mm, 10 mm, 15 mm, 16 mm, 17 mm, 18 mm, 19 mm, 20 mm, 25 mm, 30 mm.

The scan volume may be about 20 mm x 20 mm.

15

Fig. 3 shows an example of a handheld 3D scanner.

The handheld scanner 301 comprises a light source 302 for emitting light, a beam splitter 304, movable focus optic 305, such as lenses, an image sensor 306, and a tip or probe 307 for scanning an object 308. In this example the  
20 object 308 is teeth in an intra oral cavity.

The scanner comprises a scan head or tip or probe 307 which can be entered into a cavity for scanning an object 308. The light from the light source 302 travels back and forth through the optical system. During this  
25 passage the optical system images the object 308 being scanned onto the image sensor 306. The movable focus optics comprises a focusing element which can be adjusted to shift the focal imaging plane on the probed object 308. One way to embody the focusing element is to physically move a single lens element back and forth along the optical axis. The device may include  
30 polarization optics and/or folding optics which directs the light out of the device in a direction different to the optical axis of the lens system, e.g. in a

direction perpendicular to the optical axis of the lens system. As a whole, the optical system provides an imaging onto the object being probed and from the object being probed to the image sensor, e.g. camera. One application of the device could be for determining the 3D structure of teeth in the oral cavity. Another application could be for determining the 3D shape of the ear canal and the external part of the ear.

The optical axis in fig. 3 is the axis defined by a straight line through the light source, optics and the lenses in the optical system. This also corresponds to the longitudinal axis of the scanner illustrated in fig. 3. The optical path is the path of the light from the light source to the object and back to the camera. The optical path may change direction, e.g. by means of beam splitter and folding optic.

The focus element is adjusted in such a way that the image on the scanned object is shifted along the optical axis, for example in equal steps from one end of the scanning region to the other. A pattern may be imaged on the object, and when the pattern is varied in time in a periodic fashion for a fixed focus position then the in-focus regions on the object will display a spatially varying pattern. The out-of-focus regions will display smaller or no contrast in the light variation. The 3D surface structure of the probed object may be determined by finding the plane corresponding to an extremum in the correlation measure for each sensor in the image sensor array or each group of sensor in the image sensor array when recording the correlation measure for a range of different focus positions. Preferably one would move the focus position in equal steps from one end of the scanning region to the other. The distance from one end of the scanning region to the other may be such as 5 mm, 10 mm, 15 mm, 16 mm, 20 mm, 25 mm, 30 mm etc.

Fig. 4 shows an example of a section of teeth in the mouth which can be covered in a sub-scan.

In fig. 4a) the teeth 408 are seen in a top view, and in fig. 4b) the teeth 408 are seen in a perspective view.

An example of the scan volume 411 for one sequence of focus plane images is indicated by the transparent box. The scan volume may be such as  
5 17x15x20 mm, where the 15 mm may be the "height" of the scan volume corresponding to the distance the focus optics can move.

Fig. 5 shows an example of how the different sub-scans generating 3D surfaces is distributed across a set of teeth.

10 Four sub-scans 512 are indicated on the figure. Each sub-scan provides a 3D surface of the scanned teeth. The 3D surfaces may be partly overlapping, whereby a motion of the scanner performed during the acquisition of the sub-scans can be determined by comparing the overlapping parts of two or more  
15 3D surfaces.

Fig. 6 shows an example of registering/aligning representations of 3D surfaces and compensating for motion in a 3D surface.

Fig. 6a) shows a 3D surface 616, which for example may be generated from a number of focus plane images.

20 Fig. 6b) shows another 3D surface 617, which may have been generated in a subsequent sequence of focus plane images.

Fig. 6c) shows the two 3D surface 616, 617 are attempted to be aligned/registered. Since the two 3D surfaces 616, 617 have 3D points which correspond to the same area of a tooth, it is possible to perform the  
25 registration/alignment by ICP, by comparing the corresponding points in the two 3D surfaces etc.

Fig. 6d) shows the resulting 3D surface 618 when the two 3D surfaces 616, 617 have been merged together.

Fig 6e) shows that based on the resulting 3D surface 618 the relative motion performed by the scanner during the acquisition of the sub-scans or focus  
30 plane images generating 3D surface 616 and 617 can be determined, and

based on this determined motion the resulting 3D surface 618 can be corrected to a final "correct" 3D surface 619.

5 Fig. 7 shows an example of a 3D surface where overlapping sub-scans are indicated.

A number of 3D representations or sub-scans are indicated by the numbers 1-11 and the subdivision markers 712 on a 3D surface 713. The subdivision markers 712 for sub-scans 1, 3, 5, 7, 9, and 11 are with dotted lines, and the subdivision markers for sub-scan 2, 4, 6, 8, 10 are marked with full lines. The  
10 sub-scans are all overlapping with the same distance, but the overlapping distance may be different for each pair of subscans. As typically a dentist will hold the scanner and move it across the teeth of the patient, the overlapping distance depends on how fast the dentist moves the scanner and the time frame between the acquisition of each scan, so if the time frame is constant, and the dentist does not move the scanner exactly with a constant speed, the  
15 overlapping distance will not be the same for all subscans.

Fig. 8 shows an example of excluded volume.

The excluded volume 821 is the volume in space where no surface can be present. At least a part of the excluded volume 821 may correspond to the  
20 scan volume 811 of a 3D representation, since the space between the scan head 807 or the focusing optics of the 3D scanner and the captured surface 816 must be an empty space, unless a transparent object, which is not detectable by the 3D scanner, was located in the scan volume. Furthermore  
25 the volume of the scan head 807 and the 3D scanner 801 may be defined as an excluded volume 823, since the scanner and scan head occupies their own volume in space, whereby no surface can be present there. Furthermore, the tooth 808 which is being scanned also occupies a volume in space, but since the surface 816 of the tooth 808 is being captured by the  
30 scanner, it is not considered what is "behind" the surface 816.

Fig. 9 shows an example of scanning a tooth and acquiring a first and a second representation of the surface of the tooth, where no movable object is present.

Fig. 9a) shows an example of scanning the tooth 908 using a 3D scanner 901 for acquiring a first 3D representation 916 of the surface of the tooth 908. A first scan volume 911 in space is related to the first representation, and a first excluded volume 921 corresponds to the first scan volume 911.

Fig. 9b) shows an example of scanning the tooth 908 using a 3D scanner 901 for acquiring a second 3D representation 917 of the surface of the tooth 908. A second scan volume 912 in space is related to the second representation, and a second excluded volume 922 corresponds to the second scan volume 912. The second representation is acquired with a different angle between scanner and tooth than the first representation.

No surface portion of the first representation 916 lies in the second excluded volume 922, and no surface portion of the second representation 917 lies in the first excluded volume 921, so no surface portion(s) are disregarded in the generation of the virtual 3D model in this case.

Fig. 10 shows an example of scanning a tooth and acquiring a first and a second representation of the surface of the tooth, where a movable object is captured in part of the first representation.

Fig. 10a) shows an example of scanning the tooth 1008 using a 3D scanner 1001 for acquiring a first 3D representation 1016 of the surface of the tooth 1008. A movable object 1030 is present, and a part 1016b of the first representation 1016 comprises the surface of the movable object 1030. The part 1016a of the first representation 1016 comprises the surface of the tooth. A first scan volume 1011 in space is related to the first representation, and a first excluded volume 1021 corresponds to the first scan volume 1011.

Fig. 10b) shows an example of scanning the tooth 1008 using a 3D scanner 1001 for acquiring a second 3D representation 1017 of the surface of the tooth 1008. A second scan volume 1012 in space is related to the second

representation, and a second excluded volume 1022 corresponds to the second scan volume 1012. The second representation is acquired with a different angle between scanner and tooth than the first representation.

5 Since the surface portion 1016b of the first representation 1016 lies in the second excluded volume 1022, this surface portion 1016b is disregarded in the generation of the virtual 3D model.

10 Fig. 11 shows an example of scanning a tooth and acquiring a first and a second representation of the surface of the tooth, where a movable object is captured in the second representation.

Fig. 11a) shows an example of scanning the tooth 1108 using a 3D scanner 1101 for acquiring a first 3D representation 1116 of the surface of the tooth 1108. A first scan volume 1111 in space is related to the first representation, and a first excluded volume 1121 corresponds to the first scan volume 1111.

15 Fig. 11b) shows an example of scanning the tooth 1108 using a 3D scanner 1101 for acquiring a second 3D representation 1117 of the surface of the tooth 1108. A movable object 1130 is present, and the second representation 1117 comprises the surface of the movable object 1130. A second scan volume 1112 in space is related to the second representation, and a second excluded volume 1122 corresponds to the second scan volume 1112. The second representation is acquired with a different angle between scanner and tooth than the first representation.

20 Since the surface of the second representation 1117 lies in the first excluded volume 1121, the surface of the second representation 1117 is disregarded in the generation of the virtual 3D model.

25 The figures in fig. 11 are shown in 2D, but it is understood that the figures represent 3D figures.

30 Fig. 12 shows an example of acquiring a first and a second representation of the surface of an object, e.g. a tooth, where a movable object is captured in the first representation.

Fig. 12a) shows a first 3D representation 1216 comprising two parts, part 1216a and part 1216b. The first scan volume 1211 is indicated by the vertical lines. The first excluded volume 1221 corresponds to the first scan volume.

Fig. 12b) shows a second 3D representation 1217. The second scan volume 1212 is indicated by the vertical lines. The second excluded volume 1222 corresponds to the second scan volume.

The part 1216a of the first representation 1216 corresponds to the first part of the second representation 1217, whereas the part 1216b of the second representation 1216 does not correspond to the second part of the second representation 1217.

The part 1216b of the first representation 1216 lies in the second excluded volume 1222, and the part 1216b is therefore disregarded in the generation of the virtual 3D model

Fig. 12c) shows the resulting 3D representation 1219, which corresponds to the second representation.

The figures in fig. 12 are shown in 2D, but it is understood that the figures represent 3D figures.

Fig. 13 shows an example of acquiring a first and a second representation of a surface of an object, where no movable object is present.

Fig. 13a) shows an example of acquiring a first 3D representation 1316 of a surface of an object (not shown). A first scan volume 1311 in space is related to the first representation. The first scan volume 1311 is indicated by dotted vertical lines. A first excluded volume 1321 corresponds to the first scan volume 1311.

Fig. 13b) shows an example of acquiring a second 3D representation 1317 of a surface of an object (not shown). A second scan volume 1312 in space is related to the second representation. The second scan volume 1312 is indicated by dotted vertical lines. A second excluded volume 1322 corresponds to the second scan volume 1312.

The second representation is acquired with a different angle between scanner and tooth than the first representation. Furthermore, the second representation is displaced in space relative to the first representation, so the first and second representation does not represent the same entire surface part of the object, but parts of the representations are overlapping.

5 Fig. 13c) shows an example where the first representation 1316 and the second representation 1317 are aligned/registered, such that the corresponding parts of the representations are arranged in the same location. Fig. 13d) shows an example where the overlapping common scan volume  
10 1340 of the first representation 1316 and the second representation 1317 is indicated as a shaded area. If a surface portion of one of the representations is located in the overlapping common scan volume 1340, then this corresponds to that the surface portion is located in the excluded volume of the other representation. However, in this case, no surface portion of the first  
15 representation 1316 or of the second representation 1317 lies in the overlapping common scan volume 1340, so no surface portion(s) are disregarded in the generation of the virtual 3D model in this case.

In order to be able to distinguish between the surface of the first and the surface of the second representation, these two surfaces are slightly  
20 displaced, but in a real case the surface of the first and the surface of the second representation may be exactly overlapping each other, so that the surface part from the first representation and the surface part from the second representation cannot be distinguished.

Fig. 13e) shows an example of the resulting virtual 3D surface 1319.  
25 The figures in fig. 13 are shown in 2D, but it is understood that the figures represent 3D figures.

Fig. 14 shows an example of acquiring a first and a second representation of a surface of an object, where a movable object of the second representation  
30 is present in the excluded volume of the first representation.



Fig. 14a) shows an example of acquiring a first 3D representation 1416 of a surface of an object (not shown). A first scan volume 1411 in space is related to the first representation. The first scan volume 1411 is indicated by dotted vertical lines. A first excluded volume 1421 corresponds to the first scan volume 1411.

Fig. 14b) shows an example of acquiring a second 3D representation 1417 of a surface of an object (not shown). A second scan volume 1412 in space is related to the second representation. The second scan volume 1412 is indicated by dotted vertical lines. A second excluded volume 1422 corresponds to the second scan volume 1412. The second 3D representation 1417 comprises two parts 1417a and 1417b. The part 1417b is located between the part 1417a and the scanner (not shown), which is arranged somewhere at the end of the scan volume.

The second representation is acquired with a different angle between scanner and tooth than the first representation. Furthermore, the second representation is displaced in space relative to the first representation, so the first and second representation does not represent the same entire surface part of the object, but parts of the representations are overlapping.

Fig. 14c) shows an example where the first representation 1416 and the second representation 1417 are aligned/registered, such that the corresponding parts of the representations are arranged in the same location. Some of the part 1417a of the second representation is aligned/registered with the first representation. The part 1417b cannot be aligned/registered with the first representation 1416, since there is no corresponding surface portions between the surface 1416 and the surface 1417b.

Fig. 14d) shows an example where the overlapping common scan volume 1440 of the first representation 1416 and the second representation 1417 is indicated as a shaded area. The surface portion 1417b of the second representation is located in the overlapping common scan volume 1440, and the surface portion 1417b of the second representation 1417 is therefore located in the excluded volume 1421 of the first representation 1416, and

part 1417b must therefore be a movable object, which is only present in the second representation.

In order to be able to distinguish between the surface of the first and the surface of the second representation, these two surfaces are slightly  
5 displaced, but in a real case the surface of the first and the surface of the second representation may be exactly overlapping each other, so that the surface part from the first representation and the surface part from the second representation cannot be distinguished.

Fig. 14e) shows an example of the resulting virtual 3D surface 1419, where  
10 the surface portion 1417b is disregarded in the generation of the virtual 3D model, so the virtual 3D model comprises the first representation 1416 and the part 1417a of the second representation 1417.

The figures in fig. 14 are shown in 2D, but it is understood that the figures represent 3D figures.

15

Fig. 15 shows an example of acquiring a first and a second representation of a surface of an object, where a possible movable object is present in the second representation, but not in the excluded volume of the first representation.

20 Fig. 15a) shows an example of acquiring a first 3D representation 1516 of a surface of an object (not shown). A first scan volume 1511 in space is related to the first representation. The first scan volume 1511 is indicated by dotted vertical lines. A first excluded volume 1521 corresponds to the first scan volume 1511.

25 Fig. 15b) shows an example of acquiring a second 3D representation 1517 of a surface of an object (not shown). A second scan volume 1512 in space is related to the second representation. The second scan volume 1512 is indicated by dotted vertical lines. A second excluded volume 1522 corresponds to the second scan volume 1512. The second 3D representation  
30 1517 comprises two parts 1517a and 1517b. The part 1517b is located

between the part 1517a and the scanner (not shown), which is arranged somewhere at the end of the scan volume.

The second representation 1517 is acquired with a different angle between scanner and tooth than the first representation 1516. Furthermore, the  
5 second representation is displaced in space relative to the first representation, so the first and second representation does not represent the same entire surface part of the object, but parts of the representations are overlapping.

Fig. 15c) shows an example where the first representation 1516 and the  
10 second representation 1517 are aligned/registered, such that the corresponding parts of the representations are arranged in the same location. Some of the part 1517a of the second representation is aligned/registered with the first representation 1516. The part 1517b cannot be aligned/registered with the first representation 1516, since there is no  
15 corresponding surface portions between the surface 1516 and the surface 1517b.

Fig. 15d) shows an example where the overlapping common scan volume  
20 1540 of the first representation 1516 and the second representation 1517 is indicated as a shaded area. The surface portion 1517b of the second representation is not located in the overlapping common scan volume 1540, and the surface portion 1517b of the second representation 1517 is therefore not located in the excluded volume 1521 of the first representation 1516.

In order to be able to distinguish between the surface of the first and the surface of the second representation, these two surfaces are slightly  
25 displaced, but in a real case the surface of the first and the surface of the second representation may be exactly overlapping each other, so that the surface part from the first representation and the surface part from the second representation cannot be distinguished.

Fig. 15e) shows an example of the resulting virtual 3D surface 1519, where  
30 the surface portion 1517b is not disregarded in the generation of the virtual

3D model, so the virtual 3D model comprises the first representation 1516 and both parts, 1517a and 1517b, of the second representation 1517.

Even though the surface portion 1517b probably is the representation of a movable object, at least this would be assumed if the object in this case is a tooth, since a tooth is unlikely to have a protrusion like the part 1517b of the representation shows, the surface portion 1517b cannot be disregarded yet, because the surface portion 1517b is not found to be located in any excluded volume from any representation yet. But when the scanning of the object's surface continues, there will probably be acquired a third representation which has an overlapping common scan volume with the second representation, and if the surface portion 1517b is located in the excluded volume of the third representation, then the surface portion 1517b can be disregarded from the virtual 3D model.

The figures in fig. 15 are shown in 2D, but it is understood that the figures represent 3D figures.

Fig. 16 shows an example of a threshold distance defining how far from the representation or captured surface possible movable objects are disregarded in the generation of the virtual 3D model.

A near threshold distance 1650 is defined, which determines a distance from the captured surface 1616 in a first representation, where a surface portion in the second representation (not shown) which is located within the near threshold distance 1650 from the captured surface 1616 and which is located in space in the first excluded volume 1611 is not disregarded in the generation of the virtual 3D model.

The near threshold distance is defined for avoiding that too much of a representation of a surface is incorrectly disregarded, since there may be noise in the representation and since the registration/alignment between representations or sub-scans may not be completely accurate.

Reference numeral 1607 is the scan head of the scanner 1601, and reference numeral 1608 is the volume of the tooth.

The fig. 20 is shown in 2D, but it is understood that the figure represents 3D figures.

Fig. 17 shows an example of how the excluded volume is determined.

- 5 The space may be quantized in a 3D volume grid 1760. The distance 1762 between the corners 1761 in the 3D grid 1760 may be equidistant. The single cells 1763 in the grid each comprises eight corners 1761, and when each of the eight corners 1761 has been covered by a representation, then this cell 1763 is marked as seen. Thus if all eight corners 1761 of a cell 1763 is in the
- 10 scan volume of a representation, then this cell 1763 may be marked as excluded volume. There may be such as ten, hundred, thousands or millions of cells in the space of a representation.

Fig. 18 shows examples of how movable objects can look in subscans.

- 15 Fig. 18a) shows a subscan where the tip of a finger 1870 has been captured in the subscan.
- Fig. 18b) shows an example where a dental instrument 1871 has been captured in the subscan.

- 20 Fig. 19 shows an example of a pinhole scanner.

The pinhole scanner 1980 comprises a camera 1982 and a light source 1981, e.g. comprising a pattern (not shown). The light source 1981 transmits light rays 1983 to the surface 1916 from a small aperture, i.e. all the light rays 1983 transmitted to the surface 1961 are transmitted from a point. Light rays

25 1984 are reflected back from the surface 1961 and received by the camera 1982 through a small aperture.

Due to the pinhole setup, the point of light transmitted to the surface from the light source is well defined and the point of received light from the surface is also well defined.

Thus the excluded volume for a representation of the surface is defined by the volume in space that the light rays 1983 and 1984 span, and this volume is well defined due to the pinhole setup.

5 Fig. 20 shows examples of the principle of a far threshold distance from the captured surface defining a volume which is not included in the excluded volume of a representation.

The light rays 2052 (shown in dotted lines) from the scan head 2007 of the scanner 2001 may spread or scatter or disperse in any directions as seen in  
10 fig. 20a), where a number of the light rays are illustrated. It is understood that only some of all the light rays are shown here. The surface area on the tooth surface where the light rays impinge has reference numeral 2016.

In fig. 20b) it is shown that even if an object 2072, such as a movable object, is arranged between the scan head 2007 and the surface 2016 of a tooth, the  
15 scanner 2001 may still capture a surface point 2053 on the tooth surface 2016 which is present or hidden "under" the object 2072, because of the angled or inclined light rays 2052. A surface point 2053 needs just be visible for one light ray from the scanner in order for that surface point to be detected.

20 Fig. 20c) shows an example of the far threshold distance 2051, which determines a distance from the captured surface 2016 in a representation, where any acquired data or surface or surface points, which is/are present or located outside the far threshold distance 2051, is not included in the excluded volume for the representation. Thus any acquired data or surface or  
25 surface points in the volume 2054 between the far threshold distance 2051 and the scan head 2007 is not used in defining the excluded volume of the representation.

Fig. 20d) shows an example where defining the far threshold distance is an advantage for avoiding that real tooth surface parts are erroneously  
30 disregarded.

The scanner 2001 should in principle capture all surface parts, 2016 and 2017, present in the scan volume, but in some cases the scanner cannot capture all surface parts in the scan volume. This may happen for example because the surface part is present outside the focus region of the scanner 2001 or of the scan head 2007 or because of poor lightning conditions for the surface part. In such cases the surface part 2017 may not be captured and registered, and an excluded volume would be determined in the space region where the surface part 2017 of the tooth surface is actually present. By defining the far threshold distance 2051 less of the scan volume is excluded, and thereby it can be avoided that a real surface part 2017 is erroneously disregarded.

The actual distance of the threshold may depend or be calculated based on the optics of the scanner. The far threshold distance may be a fixed number, such as about 0.5 mm, 1 mm, 2 mm, 3 mm, 4 mm, 5 mm, 6 mm, 7 mm, 8 mm, 9 mm, 10 mm, 20 mm, 30 mm, 40 mm, 50 mm, 60 mm, 70 mm, 80 mm, 90 mm, or 100 mm. Alternatively, the far threshold distance may be a percentage or a fraction of the length of the scan volume, such as about 20%, 25%, 30%, 35%, 40%, 45%, or 50% of the length of the scan volume, or such as  $\frac{1}{2}$ ,  $\frac{1}{3}$ ,  $\frac{1}{4}$ ,  $\frac{1}{5}$  of the length of the scan volume.

The far threshold distance may be based on a determination of how far a distance from a detected point of the surface it is possible to scan, i.e. how much of the surface around a detected point that is visible for the scanner. If the visible distance in one direction from a surface point is short, then the far threshold distance will be smaller than if the distance in all directions from a surface point is long.

The figures in fig. 20 are shown in 2D, but it is understood that the figures represent 3D figures.

Although some embodiments have been described and shown in detail, the invention is not restricted to them, but may also be embodied in other ways within the scope of the subject matter defined in the following claims. In

particular, it is to be understood that other embodiments may be utilised and structural and functional modifications may be made without departing from the scope of the present invention.

5 In device claims enumerating several means, several of these means can be embodied by one and the same item of hardware. The mere fact that certain measures are recited in mutually different dependent claims or described in different embodiments does not indicate that a combination of these measures cannot be used to advantage.

10

A claim may refer to any of the preceding claims, and "any" is understood to mean "any one or more" of the preceding claims.

15 It should be emphasized that the term "comprises/comprising" when used in this specification is taken to specify the presence of stated features, integers, steps or components but does not preclude the presence or addition of one or more other features, integers, steps, components or groups thereof.

20 The features of the method described above and in the following may be implemented in software and carried out on a data processing system or other processing means caused by the execution of computer-executable instructions. The instructions may be program code means loaded in a memory, such as a RAM, from a storage medium or from another computer via a computer network. Alternatively, the described features may be  
25 implemented by hardwired circuitry instead of software or in combination with software.



**Claims:**

1. A method for detecting a movable object in a location, when scanning a rigid object in the location by means of a 3D scanner for generating a virtual  
5 3D model of the rigid object, wherein the method comprises:
- providing a first 3D representation of at least part of a surface by scanning at least part of the location;
  - providing a second 3D representation of at least part of the surface by  
10 scanning at least part of the location;
  - determining for the first 3D representation a first excluded volume in space where no surface can be present;
  - determining for the second 3D representation a second excluded volume in space where no surface can be present;
  - 15 - if a portion of the surface in the first 3D representation is located in space in the second excluded volume, the portion of the surface in the first 3D representation is disregarded in the generation of the virtual 3D model, and/or
  - if a portion of the surface in the second 3D representation is located in  
20 space in the first excluded volume, the portion of the surface in the second 3D representation is disregarded in the generation of the virtual 3D model.
2. The method according to any one or more of the preceding claims, wherein the rigid object is a patient's set of teeth, and the location is the  
25 mouth of the patient.
3. The method according to any one or more of the preceding claims, wherein the movable object is a soft tissue part of the patient's mouth, such as the inside of a cheek, the tongue, lips, gums and/or loose gingival.  
30

4. The method according to any one or more of the preceding claims, wherein the movable object is a dentist's instrument or remedy which is temporarily present in the patient's mouth, such as a dental suction device, cotton rolls, and/or cotton pads.
- 5
5. The method according to any one or more of the preceding claims, wherein the movable object is a finger, such as the dentist's finger or the dental assistant's finger.
- 10
6. The method according to any one or more of the preceding claims, wherein the 3D scanner is a scanner configured for acquiring scans of an object's surface for generating a virtual 3D model of the object.
- 15
7. The method according to any one or more of the preceding claims, wherein at least part of the surface captured in the first representation and at least part of the surface captured in the second representation are overlapping the same surface part on the rigid object.
- 20
8. The method according to any one or more of the preceding claims, wherein the first representation of at least part of the surface is defined as the first representation of at least a first part of the surface, and the second representation of at least part of the surface is defined as the second representation of at least a second part of the surface.
- 25
9. The method according to any one or more of the preceding claims, wherein the first part of the surface and the second part of the surface are at least partially overlapping.
- 30
10. The method according to any one or more of the preceding claims, wherein the surface is a surface in the location.

11. The method according to any one or more of the preceding claims, wherein the surface is at least part of the surface of the rigid object and/or at least part of the surface of the movable object.

5 12. The method according to any one or more of the preceding claims, wherein the method comprises determining a first scan volume in space related to the first representation of at least part of the surface, and determining a second scan volume in space related to the second representation of at least part of the surface.

10

13. The method according to any one or more of the preceding claims, wherein the scan volume is defined by the focusing optics in the 3D scanner and the distance to the surface which is captured.

15 14. The method according to any one or more of the preceding claims, wherein the first scan volume related to the first representation of at least part of the surface is the volume in space between the focusing optics of the 3D scanner and the surface captured in the first representation; and the second scan volume related to the second representation of at least part of the  
20 surface is the volume in space between the focusing optics of the 3D scanner and the surface captured in the second representation.

15 15. The method according to any one or more of the preceding claims, wherein if no surface is captured in at least part of the first or second  
25 representation, then the first or second scan volume is the volume in space between the focusing optics of the 3D scanner and the longitudinally extent of the scan volume.

16. The method according to any one or more of the preceding claims,  
30 wherein the first excluded volume and second excluded volume in space

where no surface can be present corresponds to the first scan volume and the second scan volume, respectively.

17. The method according to any one or more of the preceding claims,  
5 wherein the volume of the 3D scanner itself is defined as an excluded volume.

18. The method according to any one or more of the preceding claims,  
10 wherein the volume of the 3D scanner itself is comprised in the first excluded volume and in the second excluded volume.

19. The method according to any one or more of the preceding claims,  
wherein a near threshold distance is defined, which determines a distance  
15 from the captured surface in the first representation and the second representation, where a surface portion in the second representation or the first representation, respectively, which is located within the near threshold distance from the captured surface and which is located in space in the first excluded volume or in the second excluded volume, respectively, is not disregarded in the generation of the virtual 3D model.

20. The method according to any one or more of the preceding claims,  
20 wherein a far threshold distance is defined, which determines a distance from the captured surface, where the volume outside the far threshold distance is not included in the excluded volume of a representation.

21. The method according to any one or more of the preceding claims,  
25 wherein the first representation of at least part of a surface is a first subscan of at least part of the location, and the second representation of at least part of the surface is a second subscan of at least part of the location.

30

22. The method according to any one or more of the preceding claims, wherein the first representation of at least part of a surface is a provisional virtual 3D model comprising the subscans of the location acquired already, and the second representation of at least part of the surface is a second  
5 subscan of at least part of the location.

23. The method according to any one or more of the preceding claims, wherein acquired subscans of the location are adapted to be added to the provisional virtual 3D model concurrently with the acquisition of the  
10 subscans.

24. The method according to any one or more of the preceding claims, wherein the provisional virtual 3D model is termed as the virtual 3D model, when the scanning of the rigid object is finished.  
15

25. The method according to any one or more of the preceding claims, wherein the method comprises:

- providing a third 3D representation of at least part of a surface by scanning at least part of the location;
- 20 - determine for the third 3D representation a third excluded volume in space where no surface can be present;
- if a portion of the surface in the first 3D representation is located in space in the third excluded volume, the portion of the surface in the first 3D representation is disregarded in the generation of the virtual 3D model,  
25 and/or
- if a portion of the surface in the second 3D representation is located in space in the third excluded volume, the portion of the surface in the second 3D representation is disregarded in the generation of the virtual 3D model, and/or
- 30 - if a portion of the surface in the third 3D representation is located in space in the first excluded volume and/or in the second excluded volume, the

portion of the surface in the third 3D representation is disregarded in the generation of the virtual 3D model.

26. The method according to any one or more of the preceding claims,  
5 wherein the provisional virtual 3D model comprises the first representation of at least part of the surface and the second representation of at least part of the surface, and where the third representation of at least part of the surface is added to the provisional virtual 3D model.
- 10 27. The method according to any one or more of the preceding claims, wherein the virtual 3D model is used for virtually designing a restoration for one or more of the patient's teeth.
28. The method according to any one or more of the preceding claims,  
15 wherein the virtual 3D model is used for virtually planning and designing an orthodontic treatment for the patient.
29. The method according to any one or more of the preceding claims,  
20 wherein the relative motion of the scanner and the rigid object is determined.
30. The method according to any one or more of the preceding claims,  
wherein the relative motion of the scanner and the rigid object is determined by means of motion sensors.
- 25 31. The method according to any one or more of the preceding claims, wherein the relative motion of the scanner and the rigid object is determined by registering/aligning the first representation and the second representation.
- 30 32. The method according to any one or more of the preceding claims, wherein the first representation and the second representation are

aligned/registered before the first excluded volume and the second excluded volume are determined.

33. The method according to any one or more of the preceding claims,  
5 wherein the relative motion of the scanner and the rigid object determined by means of the motions sensors is verified and potentially adjusted by registering/aligning the first representation and the second representation.

34. The method according to any one or more of the preceding claims,  
10 wherein motion sensors are used for an initial determination of the relative motion of the scanner and the rigid object, and where registering/aligning is used for the final determination of the relative motion of the scanner and the rigid object.

15 35. The method according to any one or more of the preceding claims, wherein the optical system of the scanner is telecentric.

36. The method according to any one or more of the preceding claims,  
20 wherein the optical system of the scanner is perspective.

37. The method according to any one or more of the preceding claims,  
wherein a mirror in a scan head of the scanner provides that the light rays from the light source in the scanner are transmitted with an angle relative to the opening of the scan head.

25 38. The method according to any one or more of the preceding claims, wherein the 3D scanner is a hand-held scanner.

39. The method according to any one or more of the preceding claims,  
30 wherein the scanner is a pinhole scanner.

40. The method according to any one or more of the preceding claims, wherein the scanner comprises an aperture, and where the size of the aperture is less than 1/100 of the distance between it and the projected image.

5

41. The method according to any one or more of the preceding claims, wherein the scanner comprises an aperture, and where the size of the aperture is more than 1/100 of the distance between it and the projected image.

10

42. A method for detecting movable objects in the mouth of a patient, when scanning the patient's set of teeth in the mouth by means of a 3D scanner for generating a virtual 3D model of the set of teeth, wherein the method comprises:

15

- providing a first 3D representation of at least part of a surface by scanning at least part of the teeth;

- providing a second 3D representation of at least part of the surface by scanning at least part of the teeth;

20

- determining for the first 3D representation a first excluded volume in space where no surface can be present;

- determining for the second 3D representation a second excluded volume in space where no surface can be present;

25

- if a portion of the surface in the first 3D representation is located in space in the second excluded volume, the portion of the surface in the first 3D representation is disregarded in the generation of the virtual 3D model, and/or

30

- if a portion of the surface in the second 3D representation is located in space in the first excluded volume, the portion of the surface in the second 3D representation is disregarded in the generation of the virtual 3D model.



43. A method for detecting a movable object in a location, when scanning a rigid object in the location by means of a 3D scanner for generating a virtual 3D model of the rigid object, wherein the method comprises:

- 5 - providing a first representation of at least part of a surface by scanning the rigid object;
- determining a first scan volume in space related to the first representation of at least part of the surface;
- providing a second representation of at least part of the surface by scanning  
10 the rigid object;
- determining a second scan volume in space related to the second representation of at least part of the surface;
- if there is a common scan volume, where the first scan volume and the  
15 second scan volume are overlapping, then:
  - determine whether there is a volume region in the common  
scan volume which in at least one of the first representation or  
the second representation is empty and comprises no surface;  
and
  - if there is a volume region in the common scan volume which in  
20 at least one of the first representation or the second  
representation is empty and comprises no surface, then exclude  
the volume region by disregarding in the generation of the virtual  
3D model any surface portion in the second representation or in  
the first representation, respectively, which is detected in the  
25 excluded volume region, since a surface portion detected in the  
excluded volume region represents a movable object which is  
not part of the rigid object.

44. A method for detecting a movable object in a location, when scanning a  
30 rigid object in the location by means of a 3D scanner for generating a virtual  
3D model of the rigid object, wherein the method comprises:

- providing a first surface by scanning the rigid object;
  - determining a first scan volume related to the first surface;
  - providing a second surface by scanning the rigid object;
  - 5 - determining a second scan volume related to the second surface;
- where the first scan volume and the second scan volume are overlapping in an overlapping/common scan volume;
- if at least a portion of the first surface and a portion of the second surface are not coincident in the overlapping/common scan volume, then disregard
  - 10 the portion of either the first surface or the second surface in the overlapping/common scan volume which is closest to the focusing optics of the 3D scanner, as this portion of the first surface or second surface represents a movable object which is not part of the rigid object.
- 15 45. A method for detecting a movable object in the mouth of the patient, when scanning the patient's set of teeth by means of a 3D scanner for generating a virtual 3D model of the set of teeth, wherein the method comprises:
- 20 - providing a first surface by scanning the set of teeth;
  - determining a first scan volume related to the first surface;
  - providing a second surface by scanning the set of teeth;
  - determining a second scan volume related to the second surface;
- where the first scan volume and the second scan volume are overlapping in
- 25 an overlapping/common scan volume;
  - if at least a portion of the first surface and a portion of the second surface are not coincident in the overlapping/common scan volume, then disregard the portion of either the first surface or the second surface in the overlapping/common scan volume which is closest to the focusing optics of
  - 30 the 3D scanner, as this portion of the first surface or second surface represents a movable object which is not part of the set of teeth.

46. A method for detecting movable objects recorded in subscans, when scanning a set of teeth by means of a scanner for generating a virtual 3D model of the set of teeth, where the virtual 3D model is made up of the already acquired subscans of the surface of the set of teeth, and where new subscans are adapted to be added to the 3D virtual model, when they are acquired, wherein the method comprises:

- 10 - acquiring at least a first subscan of at least a first surface of part of the set of teeth, where the at least first subscan is defined as the 3D virtual model;
- acquiring a first subscan of a first surface of part of the set of teeth;
- determining a first scan volume of the first subscan;
- determining a scan volume of the virtual 3D model;
- 15 - if the first scan volume of the first subscan and the scan volume of the virtual 3D model are at least partly overlapping in a common scan volume; then:
  - calculate whether at least a portion of the first surface lies within the common scan volume;
  - calculate whether at least a portion of the surface of the virtual 20 3D model lies within the common scan volume, and
  - determine whether at least a portion of a surface is present in the overlapping volume only in one subscan and not the other subscan/3D virtual model;
  - if at least a portion of a surface is present in only one subscan, 25 then disregard the portion of the surface in the overlapping volume which is closest to the focusing optics of the scanner, since the portion of the surface represents a movable object which is not part of the set of teeth, and the portion of the surface is disregarded in the creation of the virtual 3D model of the set of 30 teeth.

47. A method for detecting movable objects recorded in subscans, when scanning a set of teeth by means of a scanner for generating a virtual 3D model of the set of teeth, wherein the method comprises:

- 5 a) providing a first subscan of a first surface of part of the set of teeth;  
b) calculating a first scan volume of the first subscan;  
c) providing a second subscan of a second surface of part of the set of teeth;  
d) calculating a second scan volume of the second subscan; and  
e) if the first scan volume and the second scan volume are at least partly  
10 overlapping in a common scan volume; then:  
f) calculate whether at least a portion of the first surface lies within the common scan volume;  
g) calculate whether at least a portion of the second surface lies within the common scan volume, and  
15 h) if at least a portion of the first surface or at least a portion of the second surface lie within the common scan volume, and the portion of the first surface or the portion of the second surface is located in space between the scanner and at least a portion of the second surface or at least a portion of the first surface,  
20 respectively;  
then the portion of the surface represents a movable object which is not part of the set of teeth, and the portion of the surface is disregarded in the creation of the virtual 3D model of the set of teeth.

25

48. The method according to the previous claims, wherein the method further comprises:

- providing a third subscan of a third surface of part of the set of teeth;  
- calculating a third scan volume of the third subscan;  
30 - if the third scan volume is at least partly overlapping with the first scan volume and/or with the second scan volume in a common scan volume; then

repeat steps f) - h) for the third subscan with respect to the first subscan and/or the second subscan.

49. A computer program product comprising program code means for causing a data processing system to perform the method of any one or more of the preceding claims, when said program code means are executed on the data processing system.

50. A computer program product according to the previous claim, comprising a computer-readable medium having stored there on the program code means.

51. A system for detecting a movable object in a location, when scanning a rigid object in the location by means of a 3D scanner for generating a virtual 3D model of the rigid object, wherein the system comprises:

- means for providing a first 3D representation of at least part of a surface by scanning at least part of the location;
- means for providing a second 3D representation of at least part of the surface by scanning at least part of the location;
- means for determining for the first 3D representation a first excluded volume in space where no surface can be present;
- means for determining for the second 3D representation a second excluded volume in space where no surface can be present;
- means for disregarding the portion of the surface in the first 3D representation in the generation of the virtual 3D model, if a portion of the surface in the first 3D representation is located in space in the second excluded volume, and/or
- means for disregarding the portion of the surface in the second 3D representation in the generation of the virtual 3D model, if a portion of the

surface in the second 3D representation is located in space in the first excluded volume.

1/19

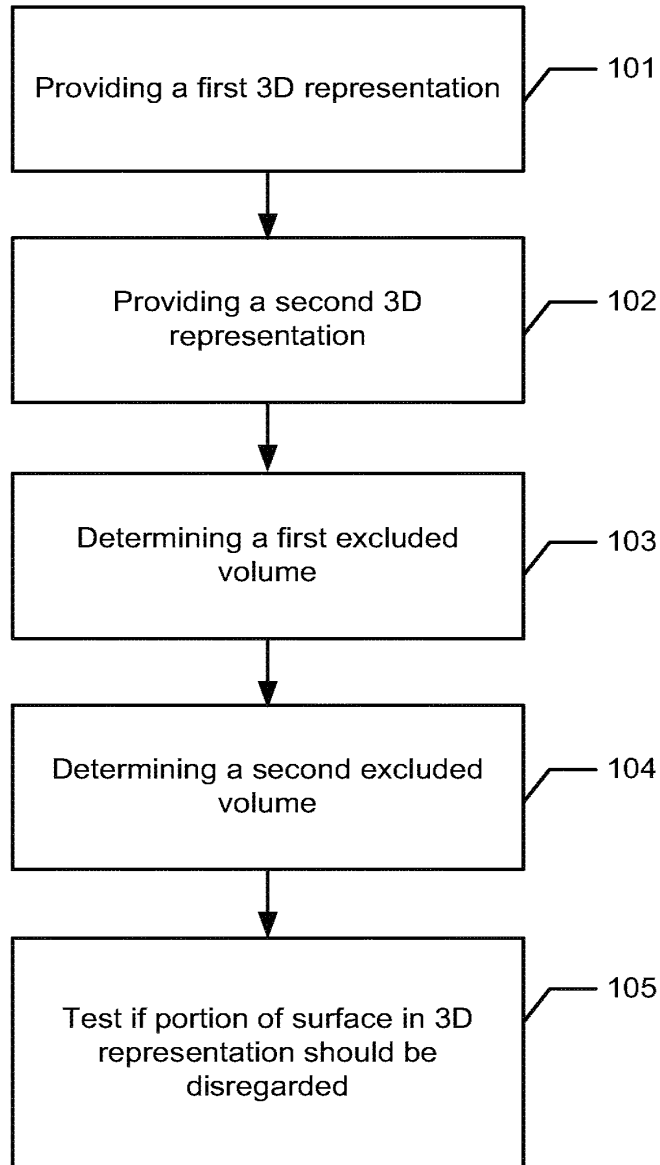
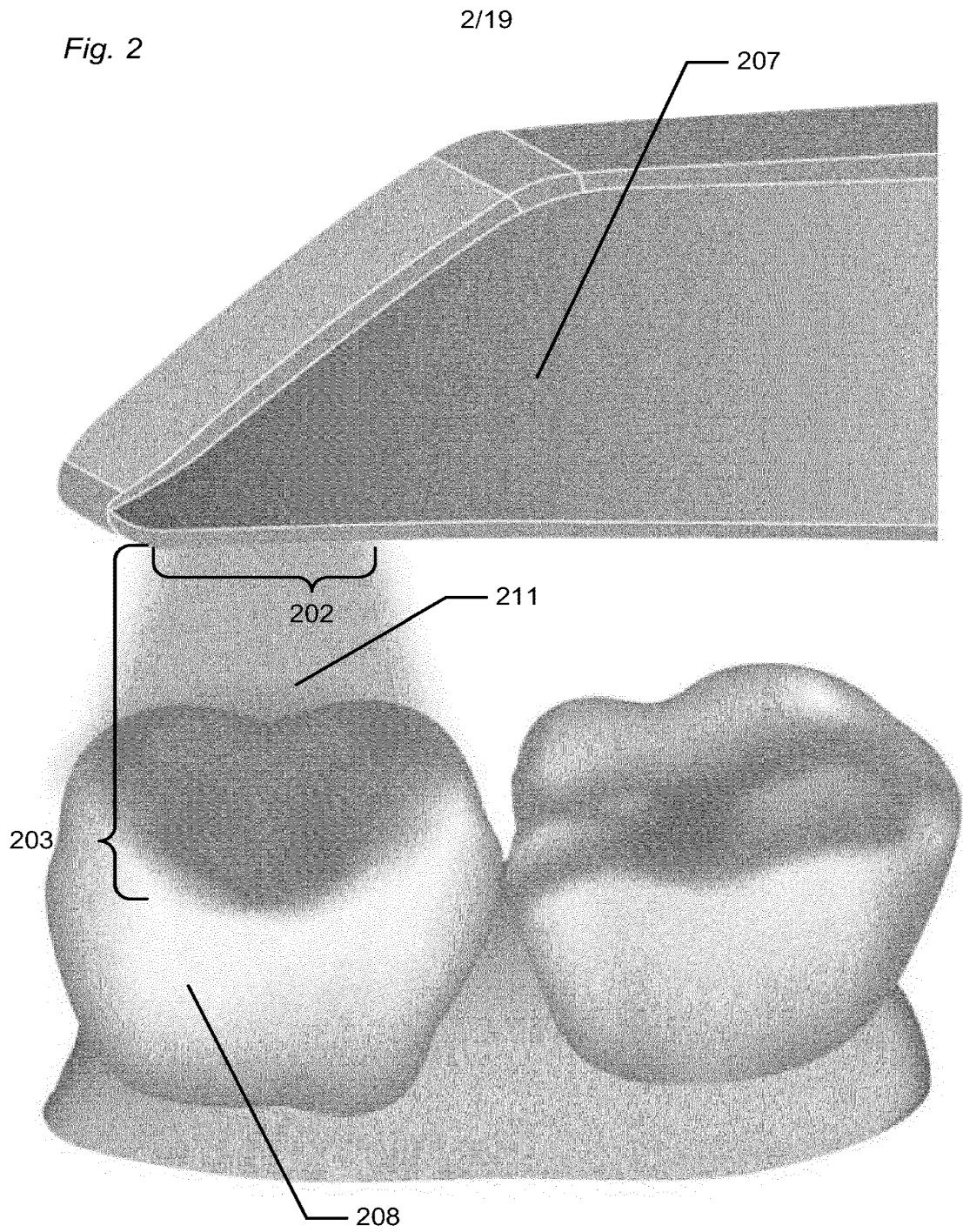
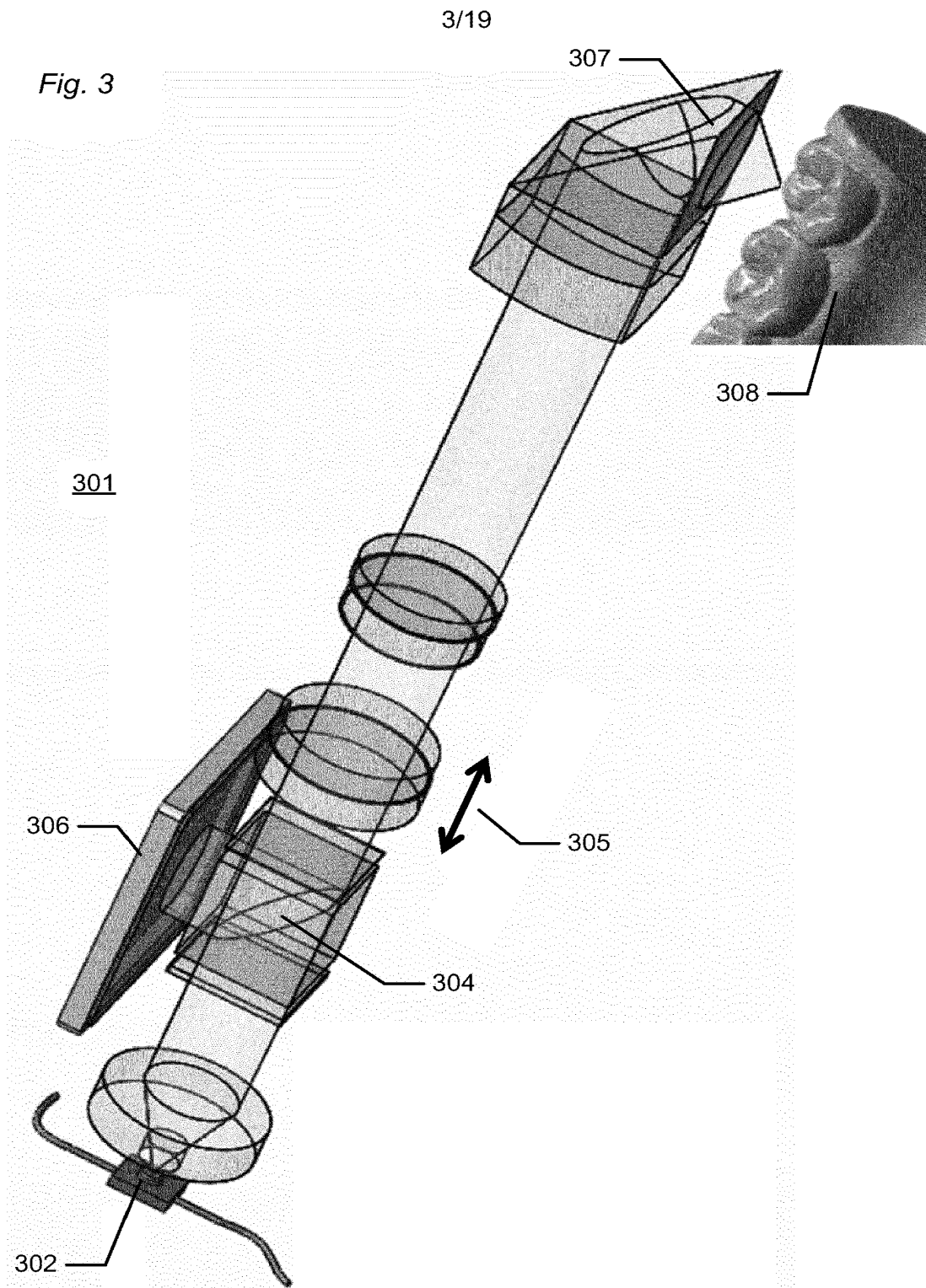

Fig. 1







4/19

Fig. 4

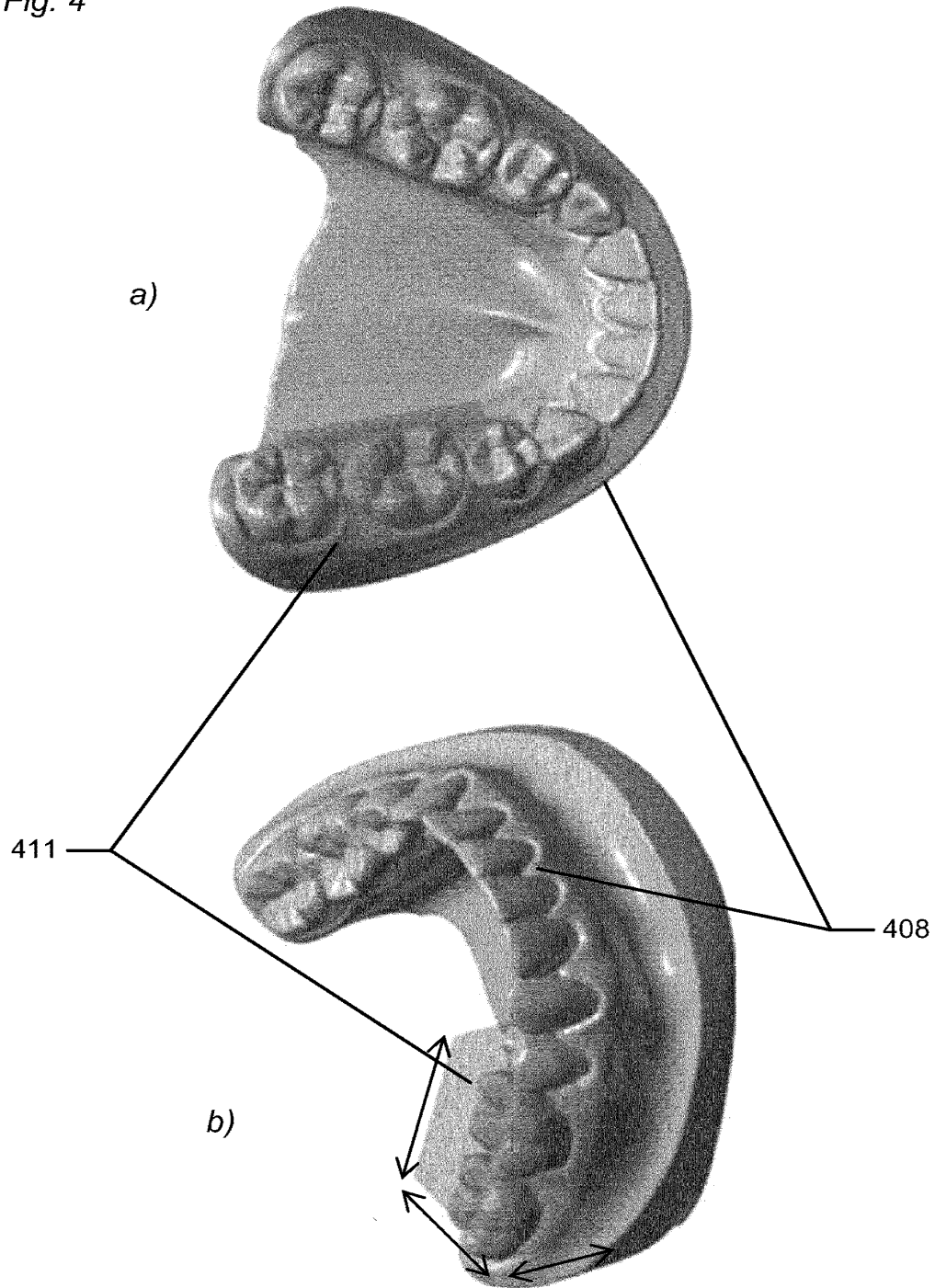

5/19

Fig. 5

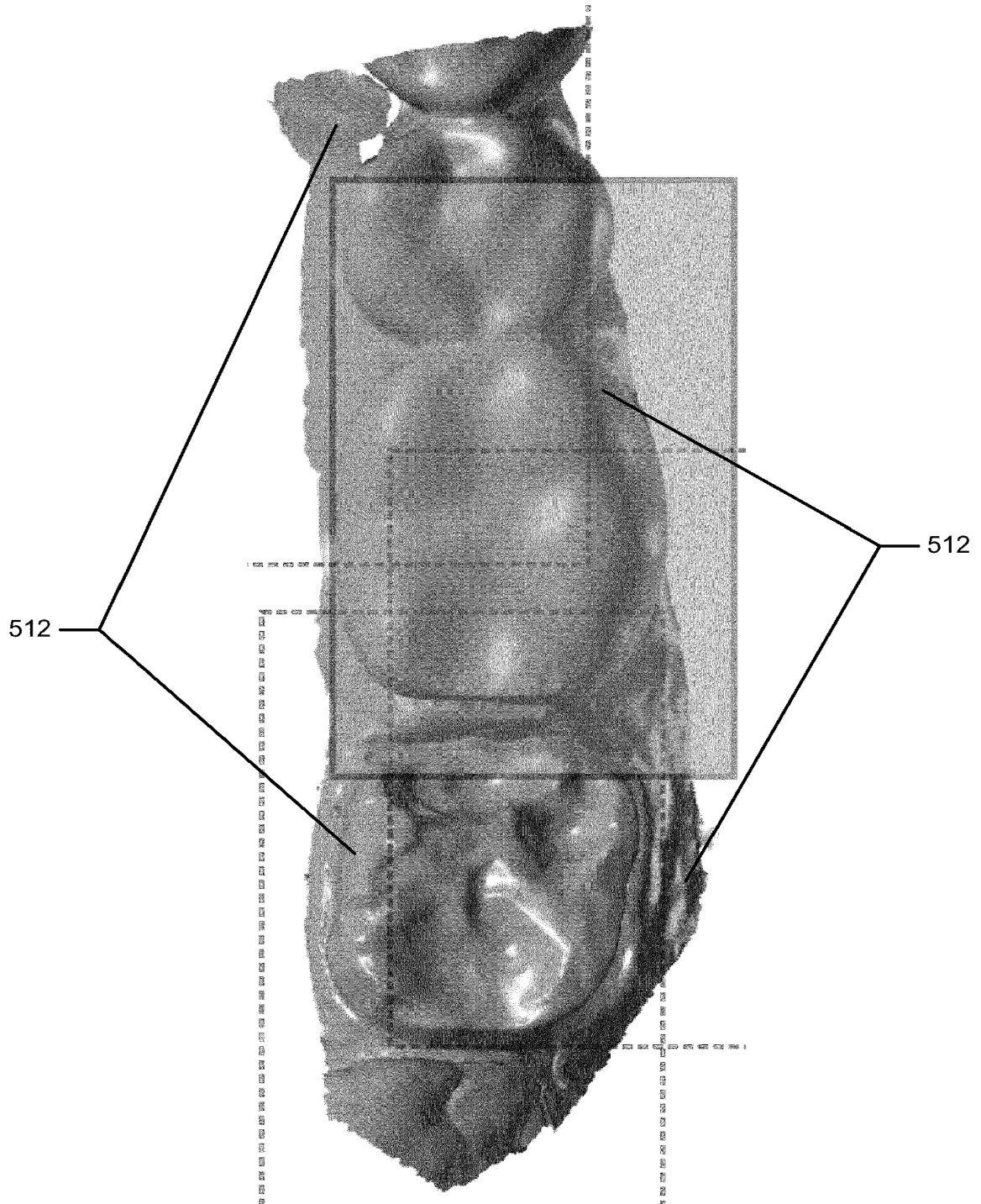

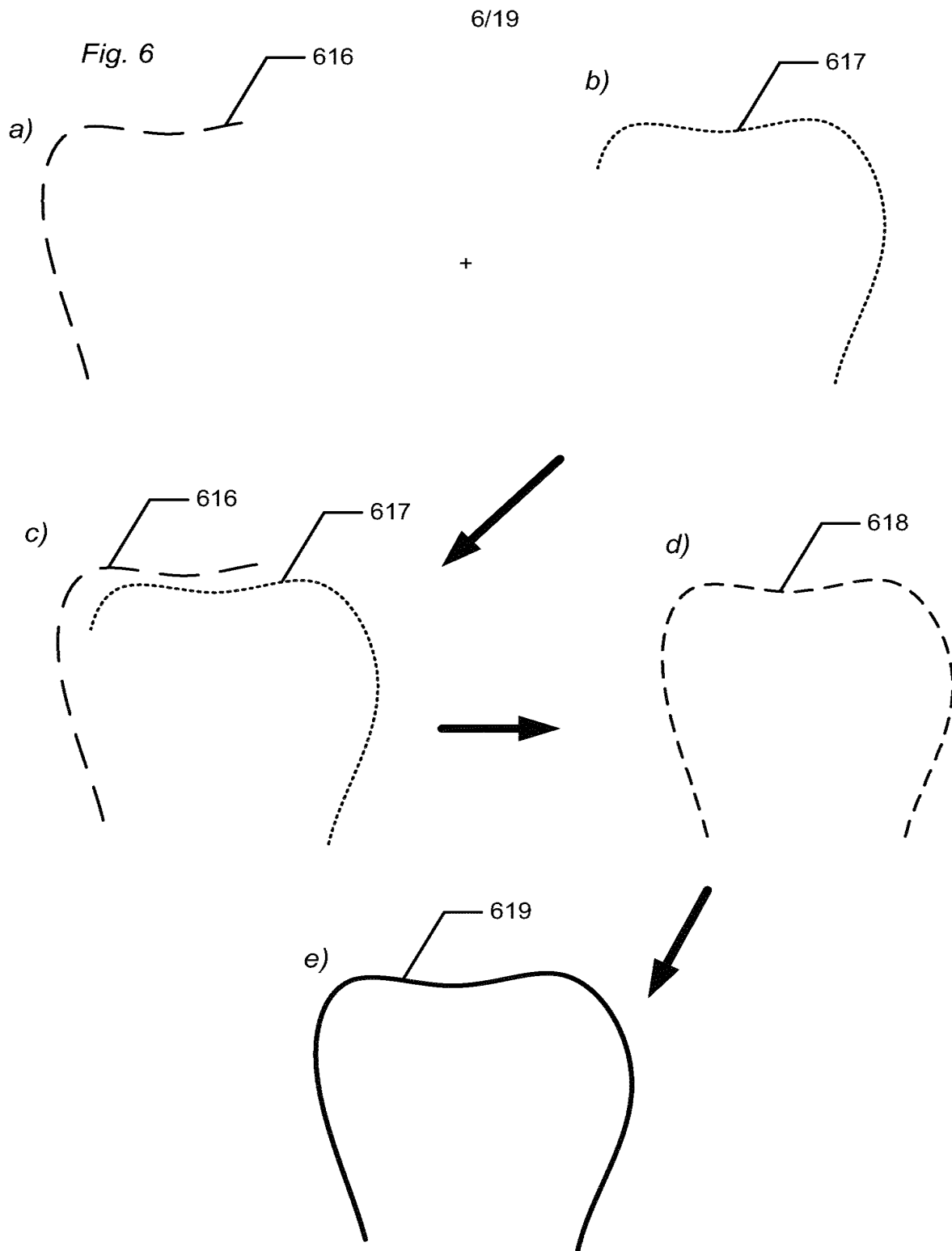

7/19

Fig. 7

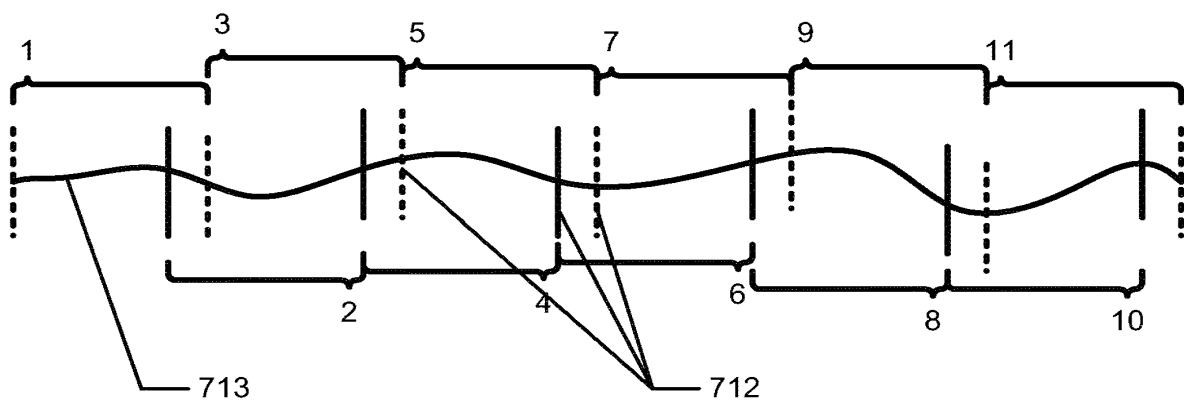
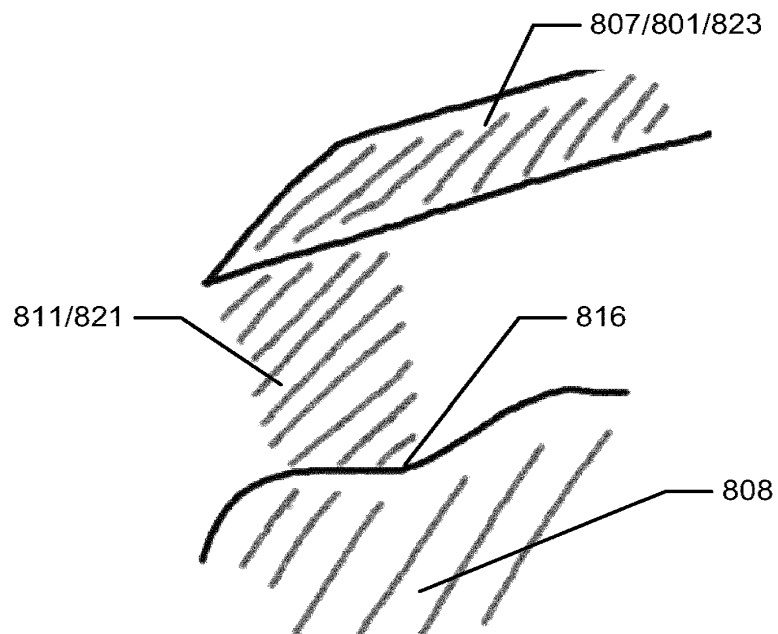

Fig. 8



8/19

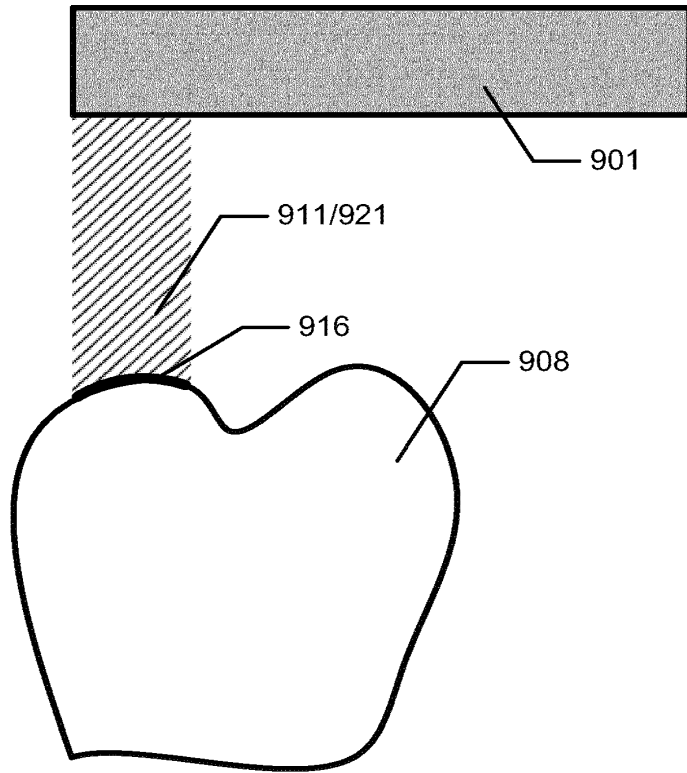

Fig. 9a)

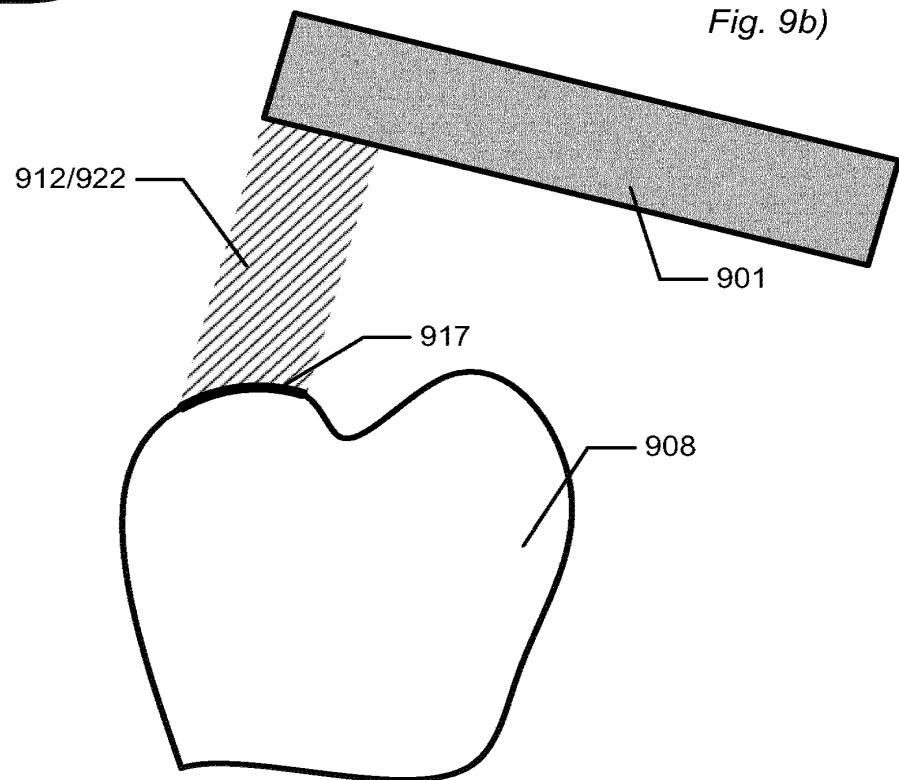

Fig. 9b)

9/19

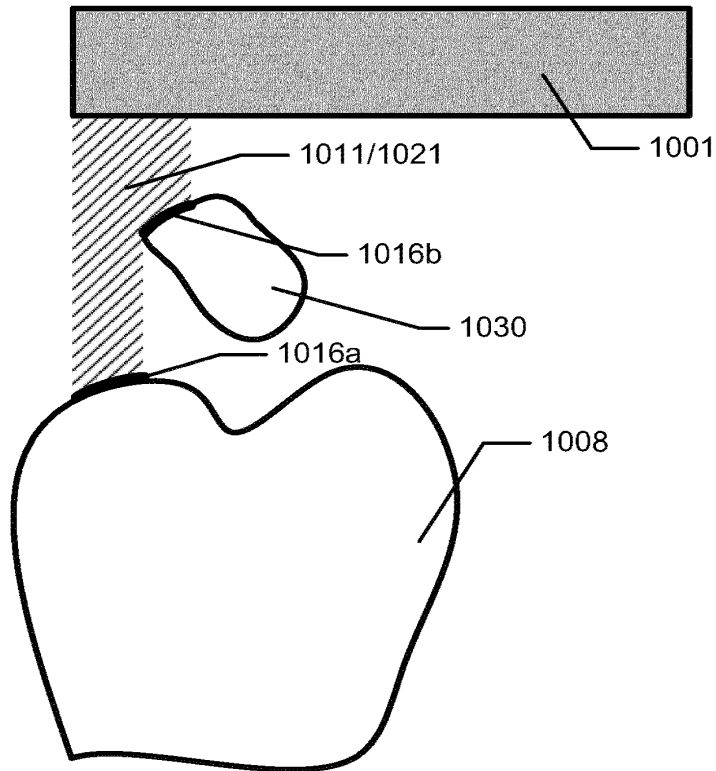

Fig. 10a)

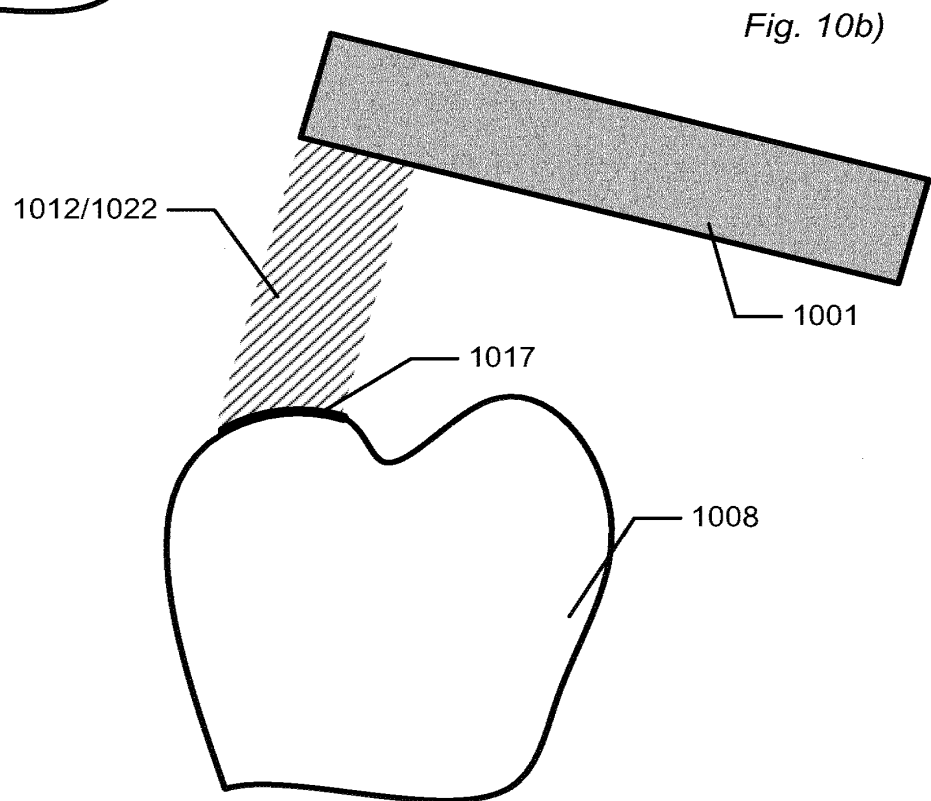

Fig. 10b)

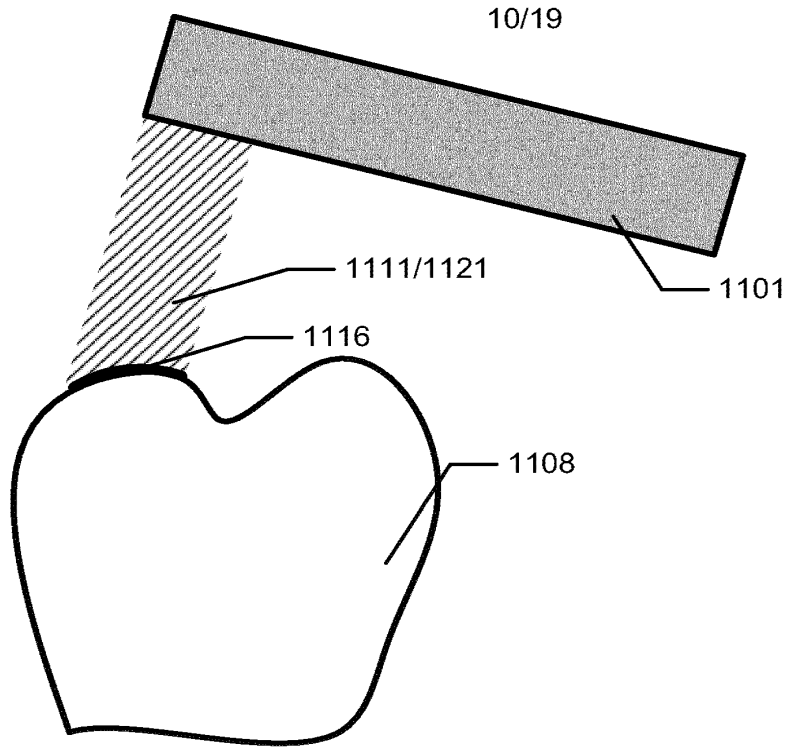

Fig. 11a)

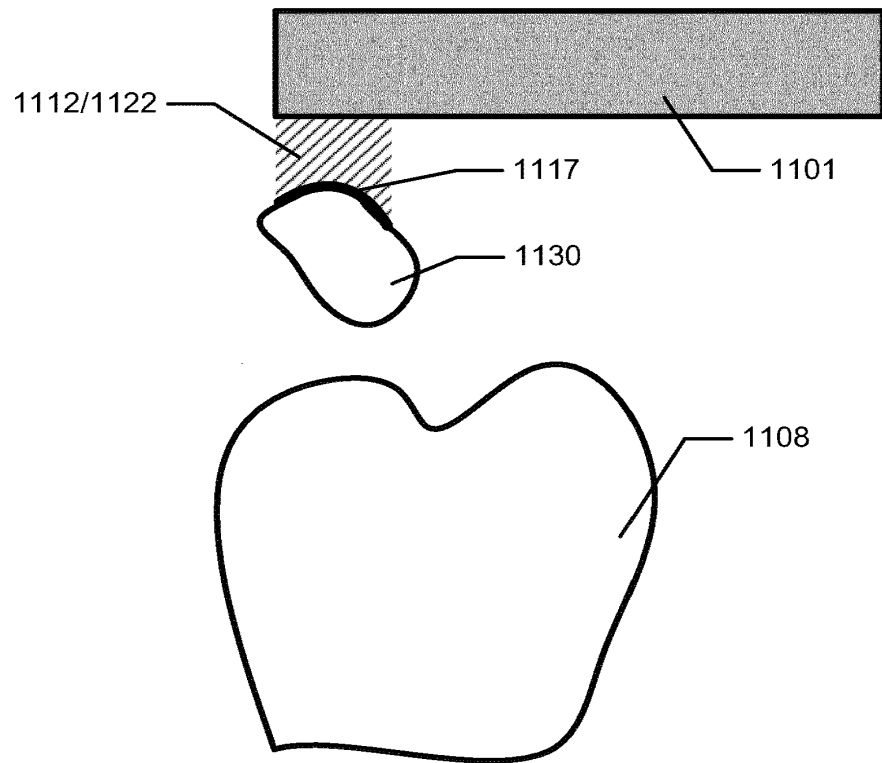
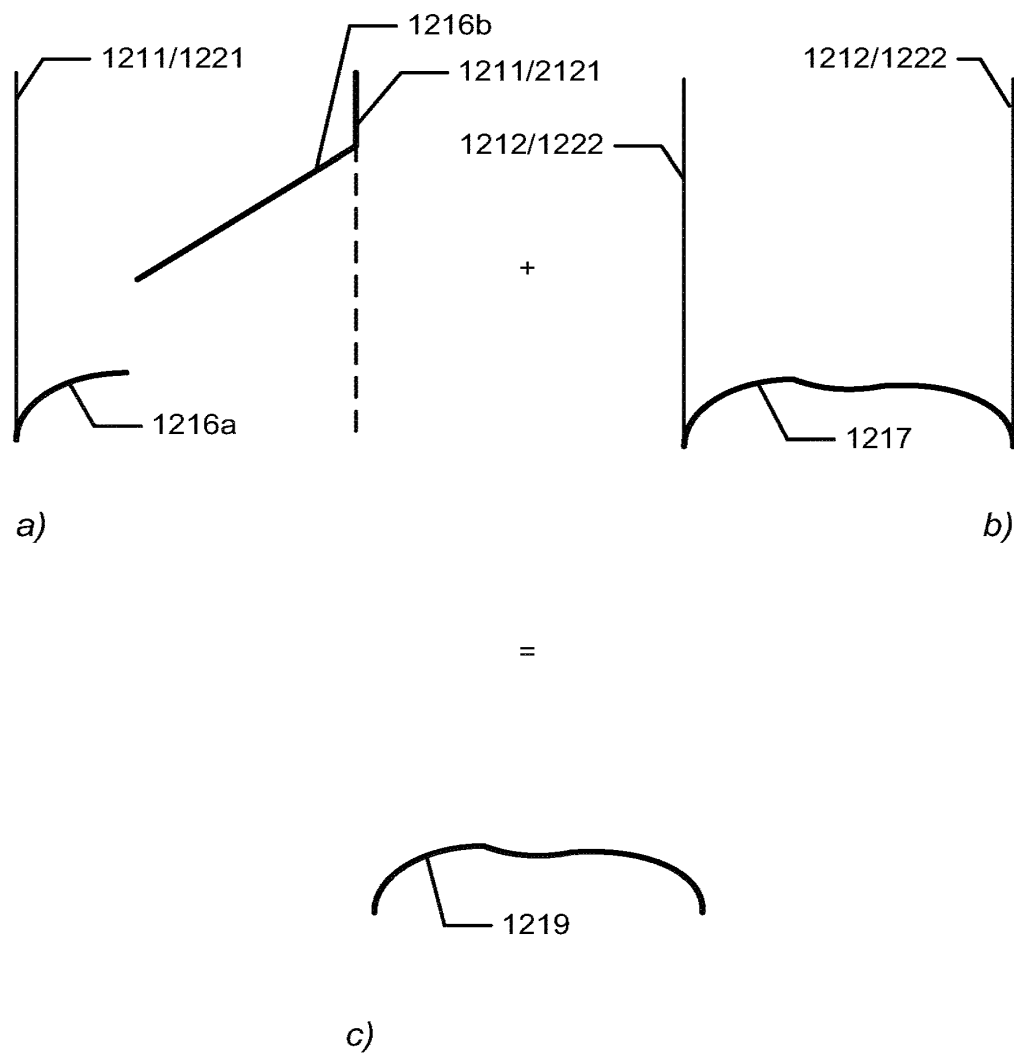

Fig. 11b)



11/19

Fig. 12



12/19

Fig. 13

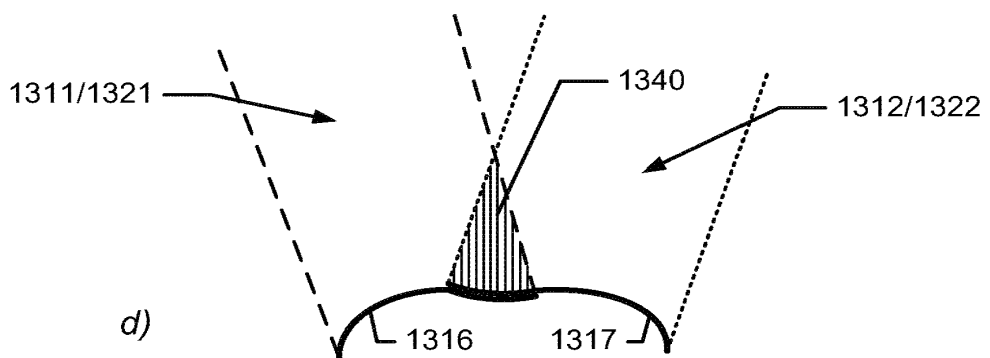
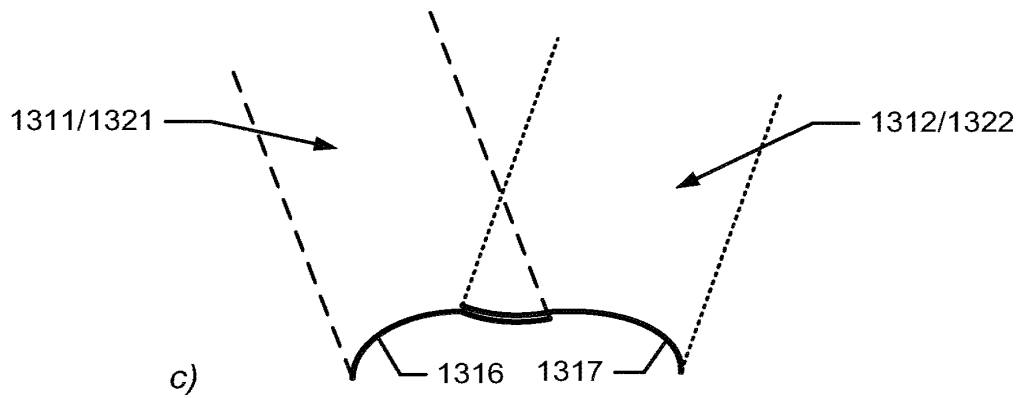
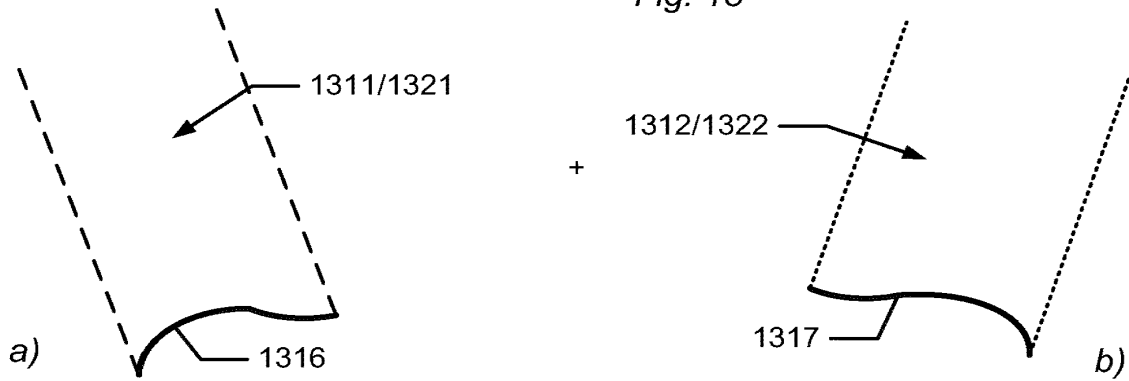

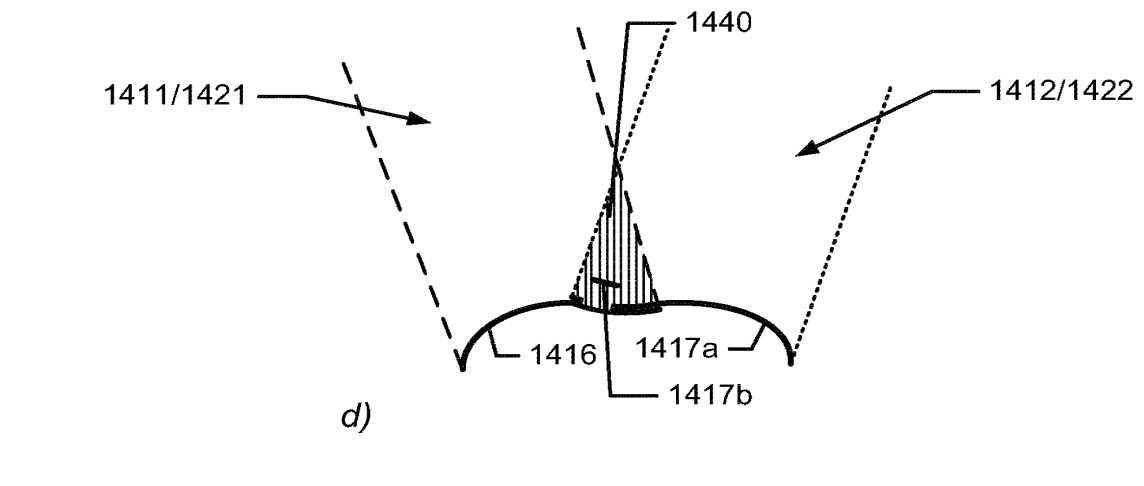
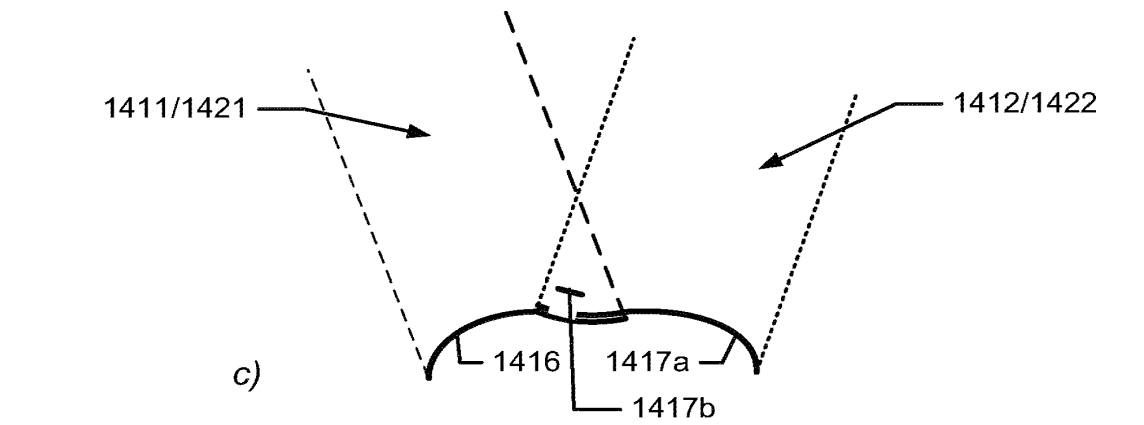
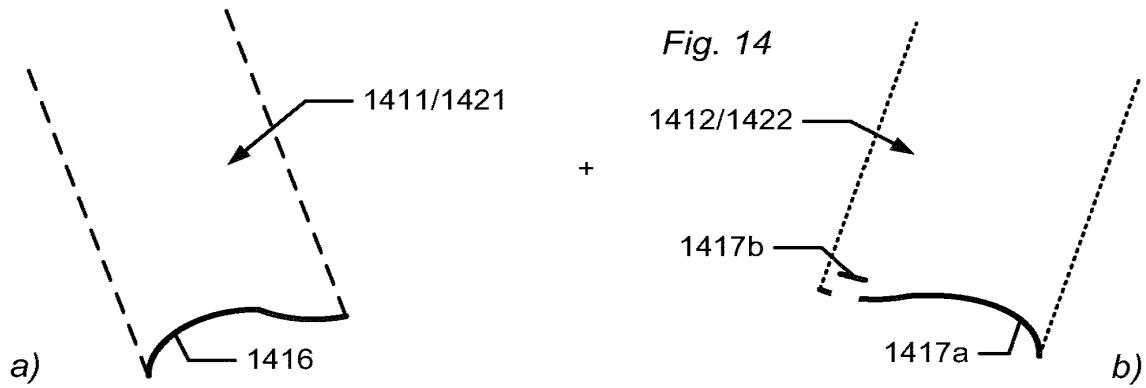

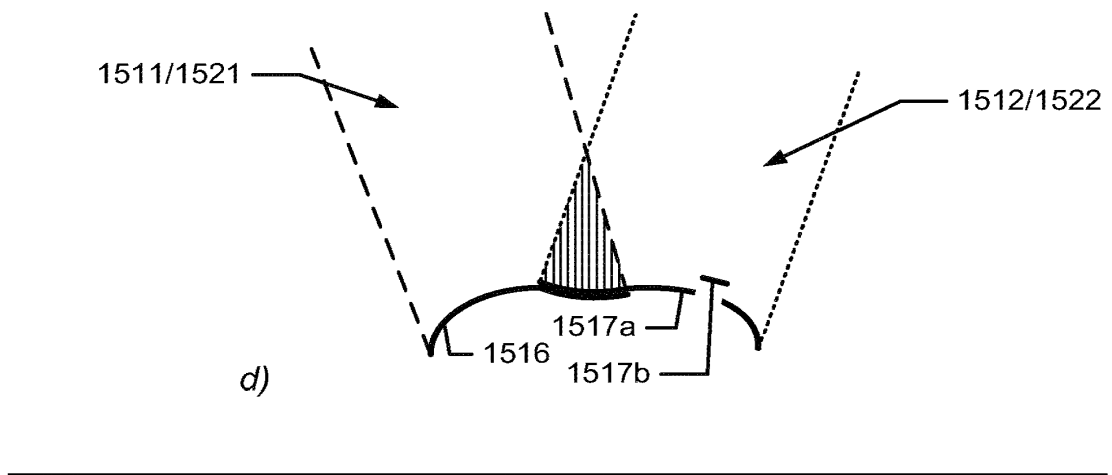
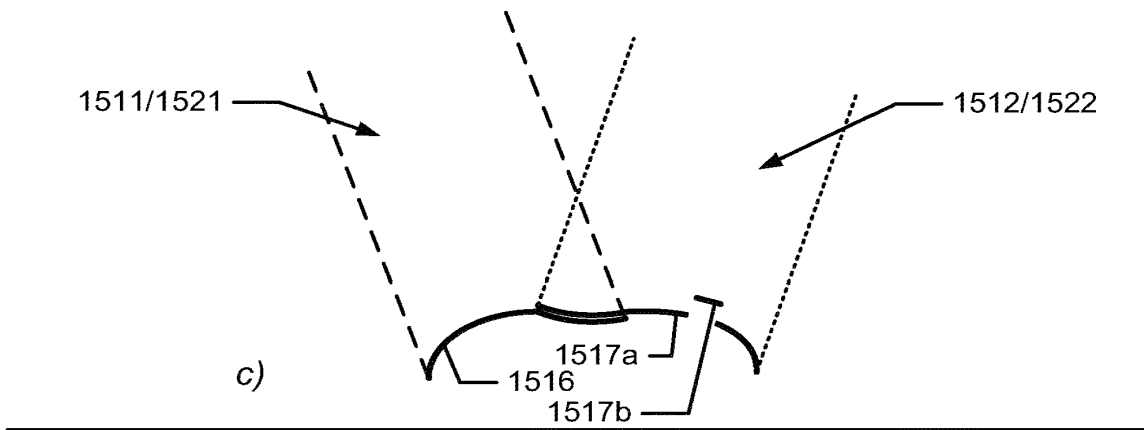
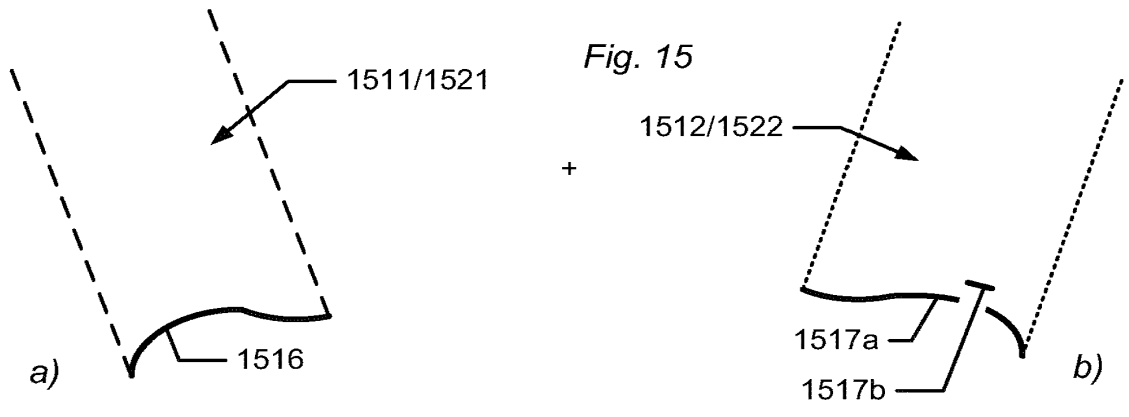

15/19

Fig. 16

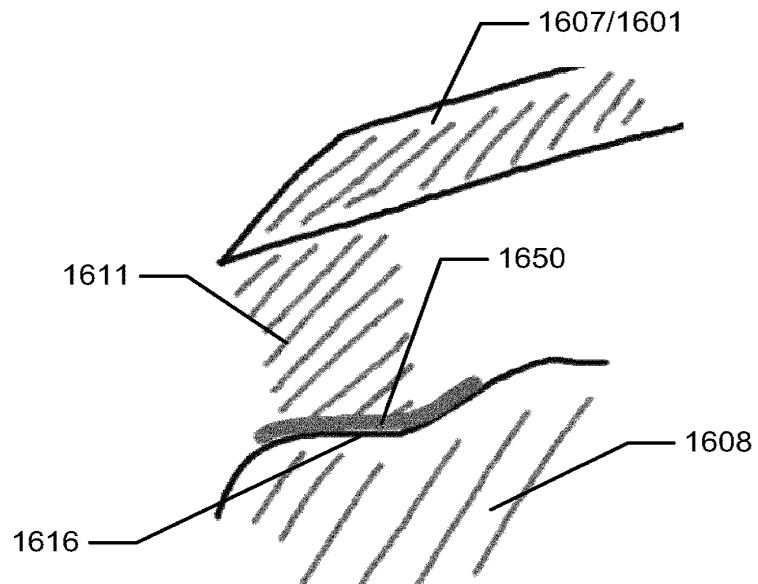
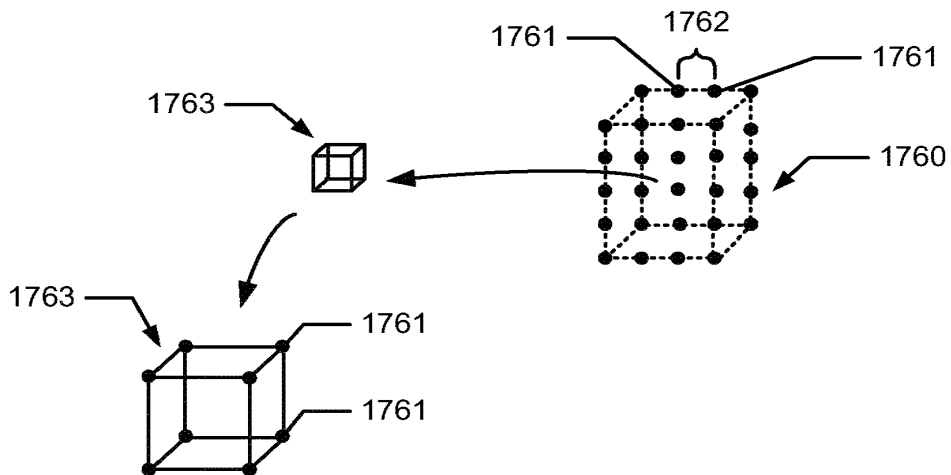

Fig. 17



16/19

Fig. 18a)

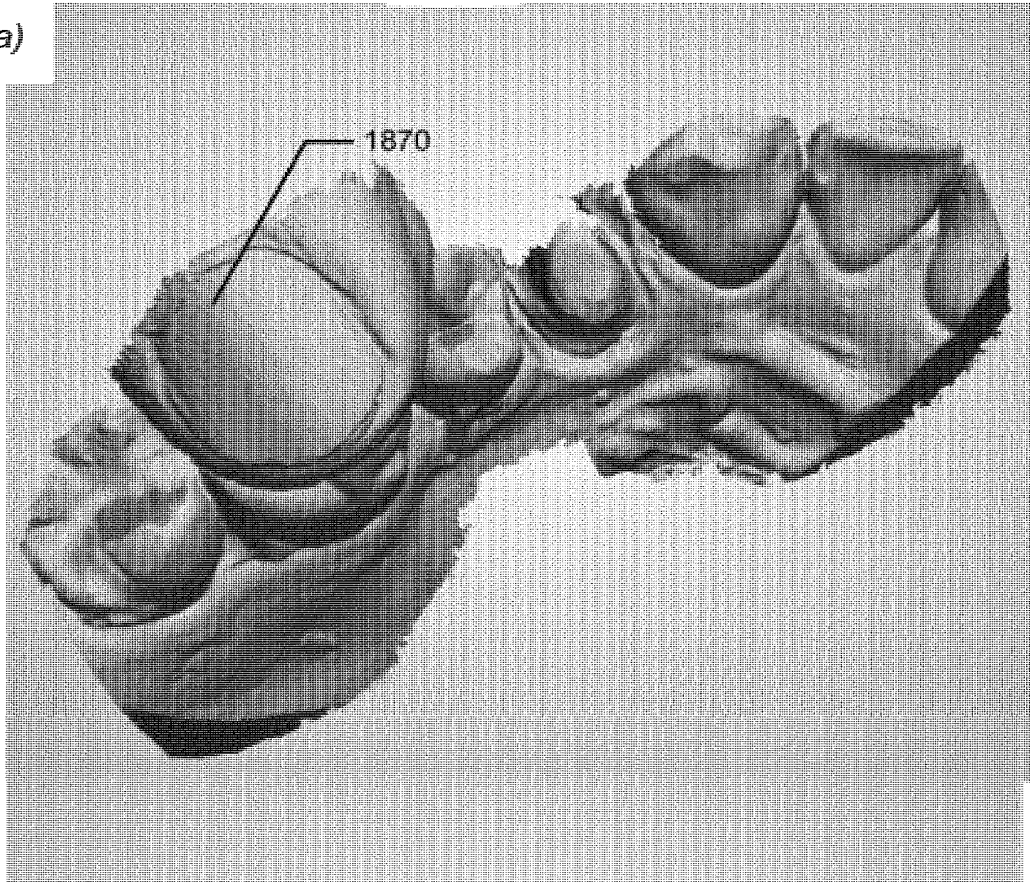
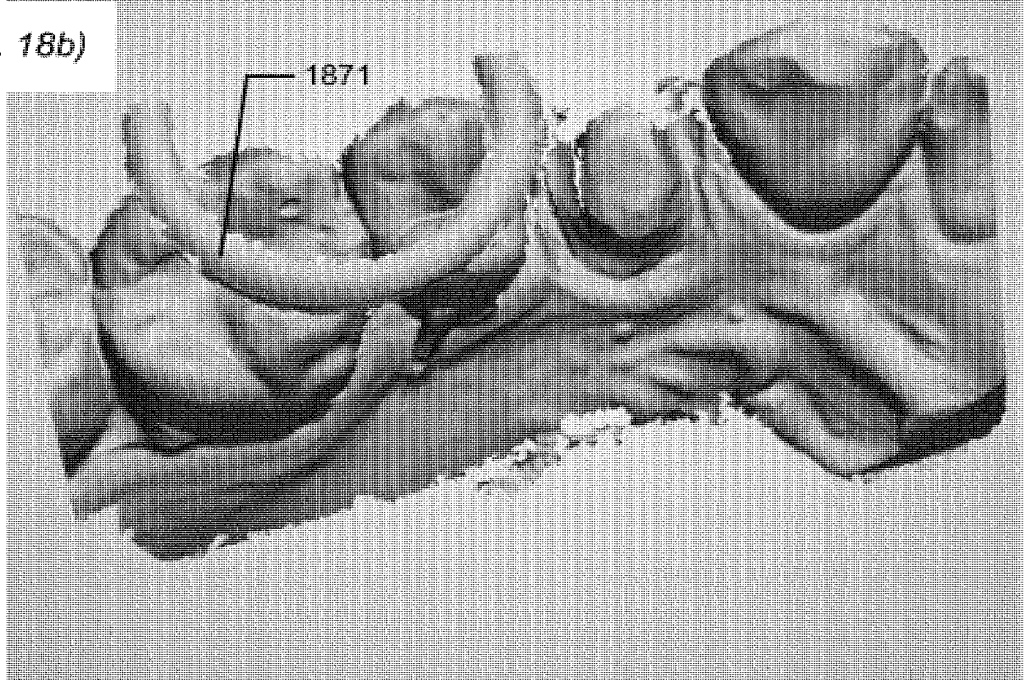

Fig. 18b)



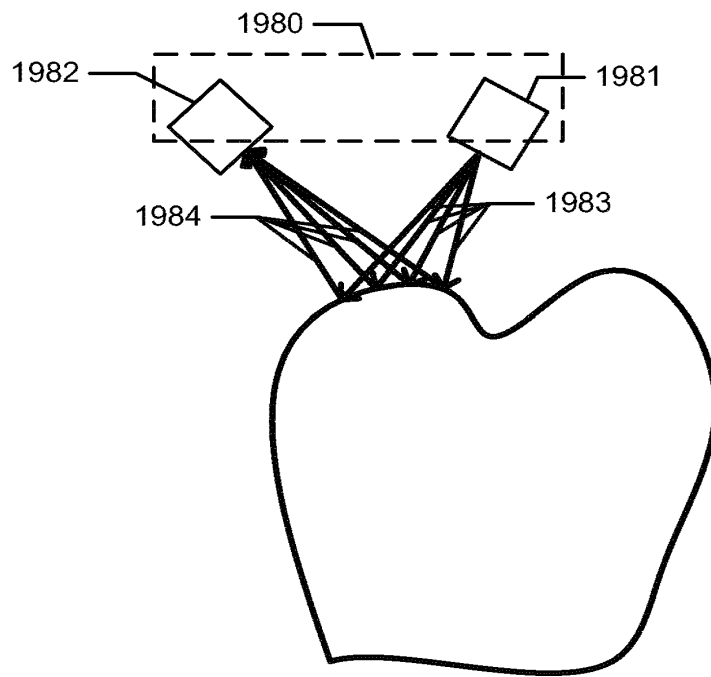

Fig. 19

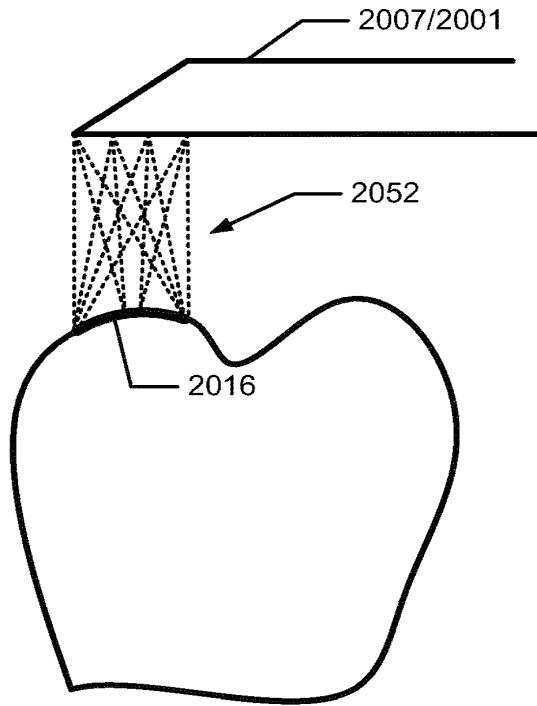

Fig. 20a)

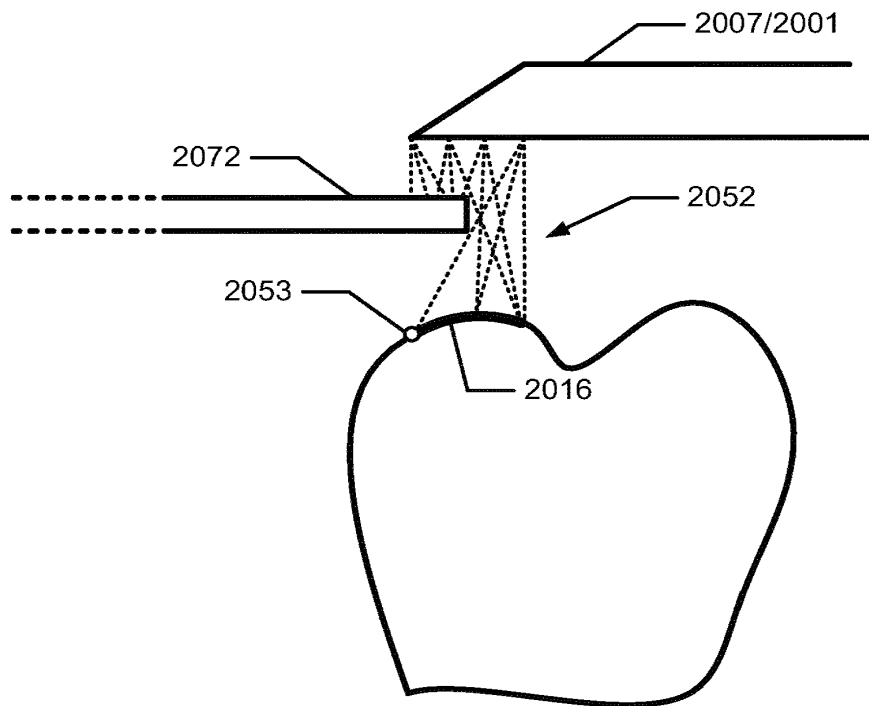

Fig. 20b)



19/19

Fig. 20c)

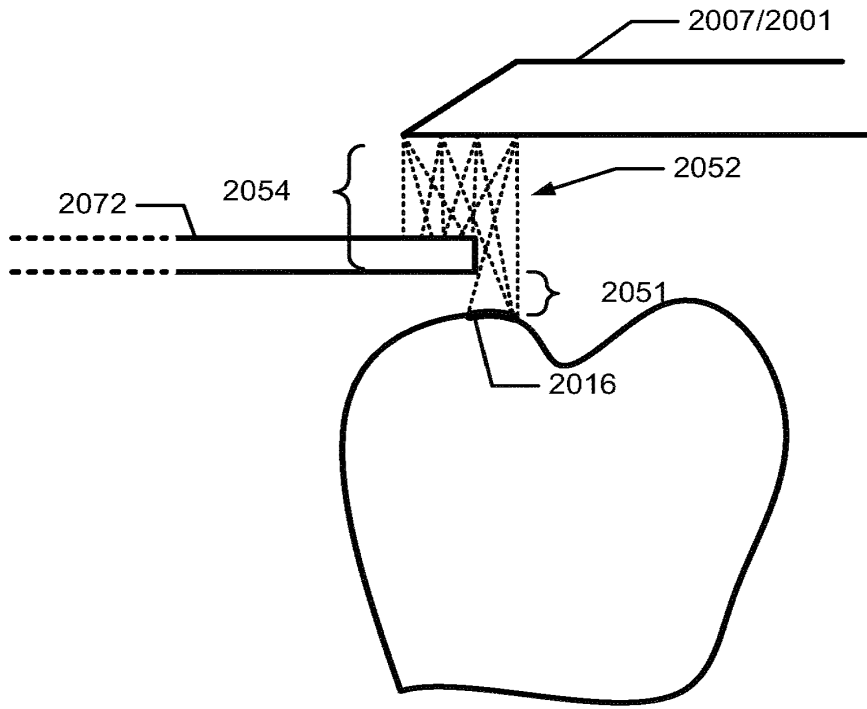
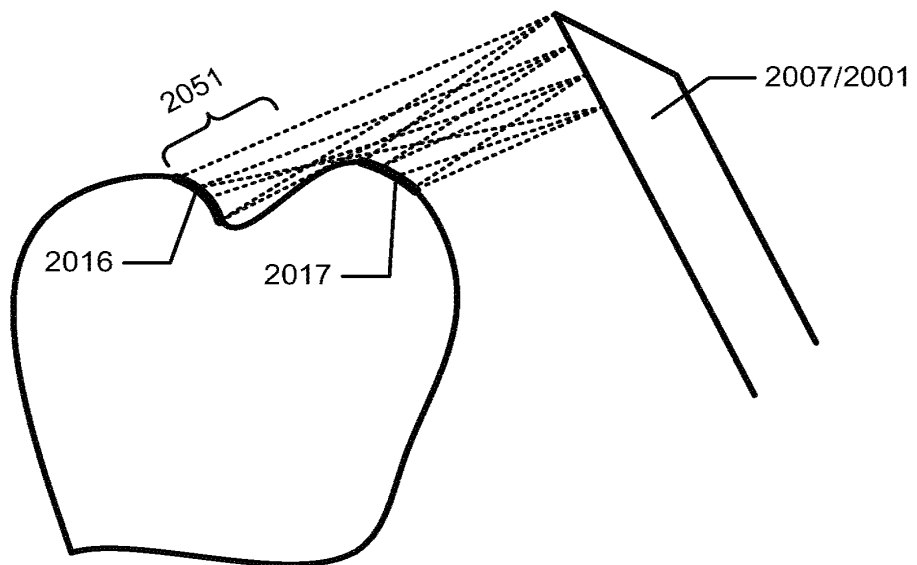

Fig. 20d)



**INTERNATIONAL SEARCH REPORT**

International application No  
PCT/EP2012/063687

**A. CLASSIFICATION OF SUBJECT MATTER**  
INV. G06T7/00  
ADD.

According to International Patent Classification (IPC) or to both national classification and IPC

**B. FIELDS SEARCHED**

Minimum documentation searched (classification system followed by classification symbols)  
G06T G06K A61B A61C

Documentation searched other than minimum documentation to the extent that such documents are included in the fields searched

Electronic data base consulted during the international search (name of data base and, where practicable, search terms used)

EPO-Internal, WPI Data

**C. DOCUMENTS CONSIDERED TO BE RELEVANT**

Category*	Citation of document, with indication, where appropriate, of the relevant passages	Relevant to claim No.
A	MEHL A ET AL: "Accuracy testing of a new intraoral 3D camera", INTERNATIONAL JOURNAL OF COMPUTERIZED DENTISTRY, QUINTESSENCE, NEW MALDEN, GB, vol. 12, no. 1, 1 January 2009 (2009-01-01), pages 11-28, XP009162619, ISSN: 1463-4201 the whole document ----- -/--	1-51

Further documents are listed in the continuation of Box C.  See patent family annex.

\* Special categories of cited documents :

"A" document defining the general state of the art which is not considered to be of particular relevance	"T" later document published after the international filing date or priority date and not in conflict with the application but cited to understand the principle or theory underlying the invention
"E" earlier application or patent but published on or after the international filing date	"X" document of particular relevance; the claimed invention cannot be considered novel or cannot be considered to involve an inventive step when the document is taken alone
"L" document which may throw doubts on priority claim(s) or which is cited to establish the publication date of another citation or other special reason (as specified)	"Y" document of particular relevance; the claimed invention cannot be considered to involve an inventive step when the document is combined with one or more other such documents, such combination being obvious to a person skilled in the art
"O" document referring to an oral disclosure, use, exhibition or other means	"&" document member of the same patent family
"P" document published prior to the international filing date but later than the priority date claimed	

Date of the actual completion of the international search <p align="center">13 September 2012</p>	Date of mailing of the international search report <p align="center">21/09/2012</p>
--	--

Name and mailing address of the ISA/ European Patent Office, P.B. 5818 Patentlaan 2 NL - 2280 HV Rijswijk Tel. (+31-70) 340-2040, Fax: (+31-70) 340-3016	Authorized officer <p align="center">Borotschnig, Hermann</p>
--	--

## INTERNATIONAL SEARCH REPORT

International application No

PCT/EP2012/063687

C(Continuation). DOCUMENTS CONSIDERED TO BE RELEVANT		
Category*	Citation of document, with indication, where appropriate, of the relevant passages	Relevant to claim No.
A	ZHIGANG ZHU ET AL: "Content-Based 3D Mosaic Representation for Video of Dynamic 3D Scenes", APPLIED IMAGERY AND PATTERN RECOGNITION WORKSHOP, 2005. PROCEEDINGS. 3 4TH WASHINGTON, DC, USA 19-21 OCT. 2005, PISCATAWAY, NJ, USA, IEEE, 19 October 2005 (2005-10-19), pages 198-203, XP010905628, DOI: 10.1109/AIPR.2005.25 ISBN: 978-0-7695-2479-5 the whole document	1-51
A	----- THOMAS POLLARD ET AL: "Change Detection in a 3-d World", CVPR '07. IEEE CONFERENCE ON COMPUTER VISION AND PATTERN RECOGNITION; 18-23 JUNE 2007; MINNEAPOLIS, MN, USA, IEEE, PISCATAWAY, NJ, USA, 1 June 2007 (2007-06-01), pages 1-6, XP031114330, ISBN: 978-1-4244-1179-5 the whole document	1-51
A	----- YAMANY S M ET AL: "Free-form surface registration using surface signatures", COMPUTER VISION, 1999. THE PROCEEDINGS OF THE SEVENTH IEEE INTERNATIONAL CONFERENCE ON KERKYRA, GREECE 20-27 SEPT. 1999, LOS ALAMITOS, CA, USA, IEEE COMPUT. SOC, US, vol. 2, 20 September 1999 (1999-09-20), pages 1098-1104, XP010350539, ISBN: 978-0-7695-0164-2 the whole document	1-51
T	----- Silvia Logozzo ET AL: "A Comparative Analysis Of Intraoral 3d Digital Scanners For Restorative Dentistry", The Internet Journal of Medical Technology, 1 January 2011 (2011-01-01), pages 1-12, XP55037945, DOI: 10.5580/1b90 Retrieved from the Internet: URL: <a href="http://www.ispub.com/journal/the-internet-journal-of-medical-technology/volume-5-number-1/a-comparative-analysis-of-intraoral-3d-digital-scanners-for-restorative-dentistry.html">http://www.ispub.com/journal/the-internet-journal-of-medical-technology/volume-5-number-1/a-comparative-analysis-of-intraoral-3d-digital-scanners-for-restorative-dentistry.html</a> [retrieved on 2012-09-12] the whole document	1-51

**Espacenet****Bibliographic data: CN101513350 (A) — 2009-08-26**

---

Device and method for displaying medical image and imaging system

**Inventor(s):** ROBERT KAGERMEIER [DE]; EIKE RIETZEL [DE]; STEFFEN SCHROETER [DE]; DIETMAR SIERK [DE] ± (KAGERMEIER ROBERT, ; RIETZEL EIKE, ; SCHROETER STEFFEN, ; SIERK DIETMAR)

**Applicant(s):** SIEMENS AG [DE] ± (SIEMENS AG)

**Classification:** - international: **A61B5/055; A61B6/03; A61B8/13; G06F3/033; G06F3/0346; G06F3/048; G06F3/0484; G09F9/00**  
- cooperative: **A61B6/548 (EP); G06F3/0346 (EP); G06F3/04845 (EP)**

**Application number:** CN20091007572 20090223

**Priority number (s):** DE20081010717 20080222

**Also published as:** DE102008010717 (A1) US2009217207 (A1)

**Abstract of CN101513350 (A)**

The invention relates to a device (1) for displaying three-dimensional medical image information (B3). The device includes a processing unit (2), a display (3), a remote control (10), a communication interface, and a software module (7). The processing unit (2) is operable to process the medical image information. The display (3) is operable to display the medical image information (B3). The remote control (10) is operable to register a user movement (B) by at least one motion-sensitive sensor (11, 12). The communication interface is operable to transfer the user movement (B) to the processing unit (2). The software module (7) is associated with the processing unit (2). The software module (7) is operable to reconcile the user movement (B) with the

medical image information (B3) so that the user movement (B) is reproduced as a virtual movement of the displayed medical image information (B3).

[19] 中华人民共和国国家知识产权局



# [12] 发明专利申请公布说明书

[21] 申请号 200910007572.1

[51] Int. Cl.

A61B 6/03 (2006.01)

A61B 8/13 (2006.01)

A61B 5/055 (2006.01)

G09F 9/00 (2006.01)

[43] 公开日 2009年8月26日

[11] 公开号 CN 101513350A

[22] 申请日 2009.2.23

[21] 申请号 200910007572.1

[30] 优先权

[32] 2008.2.22 [33] DE [31] 102008010717.4

[71] 申请人 西门子公司

地址 德国慕尼黑

[72] 发明人 罗伯特·凯杰迈耶 艾克·里策尔  
斯蒂芬·施罗特 迪特马·西尔克

[74] 专利代理机构 北京市柳沈律师事务所

代理人 谢强

权利要求书3页 说明书8页 附图4页

## [54] 发明名称

用于显示医学图像信息的装置和方法以及成像系统

## [57] 摘要

本发明涉及一种用于显示三维的医学图像信息(B3)的装置(1)，包括：用于处理图像信息(B3)的处理单元(2)；用于显示图像信息(B3)的显示元件(3)；用于借助至少一个运动敏感的传感器(11，12)采集使用者移动(B)的遥控器(10)；以及将使用者移动(B)传输到处理单元(2)的通信接口。借助所述处理装置(2)配备的软件模块(7)，与图像信息(B3)一起如下计算使用者移动(B)：将使用者移动(B)理解为所显示的图像信息(B3(PI))的虚拟运动。

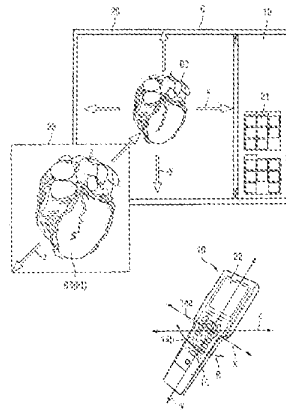

1. 一种用于显示三维医学图像信息 (B3) 的装置 (1), 包括:
  - 用于处理图像信息 (B3) 的处理单元 (2),
  - 用于显示图像信息 (B3) 的显示元件 (3),
  - 用于借助至少一个运动敏感的传感器 (11, 12) 采集使用者移动 (B) 的遥控器 (10),
    - 将使用者移动 (B) 传输到处理单元 (2) 的通信接口, 以及
    - 所述处理装置 (2) 配备的、用于与图像信息 (B3) 一起如下计算使用者移动 (B) 的软件模块 (7): 将所述使用者移动 (B) 理解为所显示的图像信息 (B3 (PI)) 的虚拟运动。
2. 根据权利要求 1 所述的装置 (1), 其中, 所述医学图像信息是三维图像信息 (B3)。
3. 根据权利要求 1 或 2 所述的装置 (1), 其中, 所述传感器是具有一个或多个测量轴线的加速度传感器 (11)。
4. 根据权利要求 1 至 3 中任一项所述的装置 (1), 其中, 所述传感器是具有一个或多个测量轴线的转动率传感器 (12)。
5. 根据权利要求 1 至 4 中任一项所述的装置 (1), 其中, 所述遥控器 (10) 具有至少一个加速度传感器 (11) 和至少一个转动率传感器 (12)。
6. 根据权利要求 1 至 5 中任一项所述的装置 (1), 其中, 作为所述通信接口 (16) 设置了无线电连接。
7. 根据权利要求 1 至 6 中任一项所述的装置 (1), 其中, 所述遥控器 (10) 具有若干用于选择各个显示模式的显示选择转换开关 (14), 并且其中, 根据所选择的显示模式将所述使用者移动 (B) 转换为虚拟运动。
8. 根据权利要求 7 所述的装置 (1), 其中, 所述遥控器 (10) 至少具有一个用于医学诊断或治疗设备 (4) 的遥控器的操作选择转换开关 (15)。
9. 根据权利要求 1 至 8 中任一项所述的装置 (1), 其中, 在静止位置设置用于容纳所述遥控器 (10) 的容纳装置 (17)。
10. 根据权利要求 9 所述的装置 (1), 其中, 所述容纳装置 (17) 具有弹性支座 (18)。

11. 一种用于显示三维医学图像信息 (B3) 的方法, 其中,
  - 利用借助至少一个运动敏感的传感器 (11, 12) 的遥控器 (10) 采集使用者移动 (B),
    - 将所述使用者移动 (B) 理解为所显示的图像信息 (B3 (PI)) 的虚拟运动。
12. 根据权利要求 11 所述的方法, 其中, 借助单轴的或多轴的加速度传感器 (11) 测量所述使用者移动 (B)。
13. 根据权利要求 11 或 12 所述的方法, 其中, 借助单轴的或多轴的转动率传感器 (12) 测量所述使用者移动 (B)。
14. 根据权利要求 11 至 13 中任一项所述的方法, 其中, 借助至少一个加速度传感器 (11) 和至少一个转动率传感器 (12) 测量所述使用者移动 (B)。
15. 根据权利要求 11 至 14 中任一项所述的方法, 其中, 经过无线电连接进行数据的传输。
16. 根据权利要求 11 至 15 中任一项所述的方法, 其中, 选择显示模式, 并且其中, 根据所选择的显示模式将所述使用者移动 (B) 转换为所述虚拟运动。
17. 根据权利要求 16 所述的方法, 其中, 显示模式提供了, 选择和至少在至少一个空间方向上移动放大的图像片段。
18. 根据权利要求 16 或 17 所述的方法, 其中, 显示模式提供了, 围绕至少一个空间轴转动所显示的图像信息 (B3 (PI))。
19. 根据权利要求 16 至 18 中任一项所述的方法, 其中, 显示模式提供了, 改变所显示的图像信息 (B3 (PI)) 的比例。
20. 根据权利要求 16 至 19 中任一项所述的方法, 其中, 显示模式提供了, 改变所显示的图像信息 (B3 (PI)) 的对比度。
21. 根据权利要求 16 至 20 中任一项所述的方法, 其中, 显示模式共同地考虑利用加速度传感器 (11) 和利用转动率传感器 (12) 的测量, 用于改变所显示的图像信息 (B3 (PI))。
22. 根据权利要求 16 至 21 中任一项所述的方法, 其中, 显示模式借助按照计算机鼠标 (9) 方式的使用者移动 (B), 允许操作作为工作位计算机运行的处理单元 (2)。
23. 根据权利要求 16 至 22 中任一项所述的方法, 其中, 在预定的时间间



隔上重复地采集所述使用者移动 (B)。

24. 根据权利要求 16 至 23 中任一项所述的方法, 其中, 只有在所述使用者移动 (B) 超过预定的阈值时, 才进行所述虚拟运动。

## 用于显示医学图像信息的装置和方法以及成像系统

### 技术领域

本发明涉及一种用于显示医学图像信息的装置和方法以及一种具有这样的装置的成像系统。

### 背景技术

对于医学图像信息的产生来说存在不同的成像系统。在此，例如是计算机断层成像（CT）、正电子发射断层成像（PET）、单光子发射计算机断层成像（SPECT）或者磁共振断层成像（MRT）。借助成像系统可以确定人的身体区域的图像信息。以下将医学图像信息理解为可以用成像系统采集的图像信息。这里通常是二维的（2D）、三维的（3D）或四维的（4D）图像信息。二维的图像信息包括两个空间维。三维的图像信息包括三个空间维或者两个空间维和时间。四维的图像信息包括三个空间维和时间。只有在不同的时刻采集身体区域时，时间作为维才是有意义的。在心脏学中通常是在检查患者的心脏时关于可能的缺陷功能在不同的心跳阶段采集图像信息，对这些心跳阶段的检查具有时间戳。

图像信息在显示单元上、通常是在监视器上被显示。借助所显示的图像信息可以建立医生对相应的身体区域的检查结果。此外，通过在进行医学干预期间在不同的时间用成像系统测量图像信息并接着由医生进行检查，所显示的图像信息使得可以监控医学的干预。

图像信息的准备（Aufbereitung）和显示通过成像系统配备的、通常被构造为计算机系统的处理单元来进行。借助操作元件、如计算机键盘或计算机鼠标，可以改变在显示元件上显示的图像信息。为此，设置了软件模块，该软件模块可以通过计算机键盘或计算机鼠标选择不同的功能，如图像信息的局部放大、图像信息的旋转等等。因此，借助计算机键盘的光标键或借助计算机鼠标的滚动按钮来进行显示的实际修改。对于计算机键盘或对于计算机鼠标需要桌面等作为支撑垫。由此不可能将计算机键盘或计算机鼠标安置在患者支撑装置（如

患者卧榻，其上安置了用于医学检查或干预的患者)的直接的附属区。特别是在执行医学干预时医生由此必须不断地在患者支撑装置和计算机键盘或计算机鼠标的位置之间变换位置，以便可以仔细查看医学干预的进程。

### 发明内容

由此本发明要解决的技术问题是，提供一种用于显示三维医学图像信息的装置，借助该装置可以按照用户友好的简单方式修改所显示的图像信息。

按照本发明，上述技术问题的解决是通过一种用于显示三维医学图像信息的装置实现的。为此设置了用于处理图像信息的处理单元和用于显示图像信息的显示元件。在此，处理单元特别地被构造为计算机系统，为该计算机系统配备有被构造为监视器的显示元件。此外，还设置了用于借助至少一个运动敏感的传感器采集使用者移动的遥控器。另外设置了将使用者移动传输到处理单元的通信接口。为处理单元配备有用于与图像信息一起计算使用者移动的软件模块。如下进行该计算：将使用者移动理解为在显示元件上所显示的图像信息的虚拟运动。以这种方式将使用者移动按照直观方式转换为在显示元件上的图像信息的类似运动。遥控器的支撑垫（如桌面等）不再是必须的。由此医生可以随身携带遥控器并且从成像系统周围的每个位置对所显示的图像信息进行改变。尤其是在显示元件的足够大尺寸的前提下，医生在进行医学干预的情况下不再必须不断地改变其位置，以便根据图像信息评价医学干预的进程。这样明显更快地并且由此对患者来说更体贴地进行医学干预。

在一种优选变形中，传感器是具有一个或多个测量轴线的加速度传感器。这样的加速度传感器例如在 US5540095 中被描述过。借助加速度传感器采集遥控器的平移运动作为使用者移动。如果是具有三个测量轴线的加速度传感器，则可以在三个空间方向上的每一个上采集遥控器的运动。使用者移动被转换为在显示元件上的图像信息的相应的平移运动。

在另一种优选变形中传感器是具有一个或多个测量轴线的转动率传感器（Drehratensensor），按照专业术语也称为陀螺仪（Gyroskop），例如在 US 6505511 B1 中被描述过。借助转动率传感器可以采集遥控器的转动或旋转运动作为使用者移动，其被理解为所显示的图像信息的转动运动或旋转。如果转动率传感器是三轴的转动率传感器，则可以用它采集遥控器的任意转动作为使用者移动并且将其理解为所显示的图像信息的虚拟运动。

在一种具有优势的扩展中，遥控器具有至少一个加速度传感器和至少一个转动率传感器。如果这两个传感器都是三轴的传感器，则借助其可以采集遥控器在空间的任意运动作为使用者移动并且将其理解为所显示的图像信息的虚拟运动。按照这种方式可以完全直观地改变在显示元件上显示的图像信息。

在一种优选扩展中，作为通信接口设置了无线电连接。由此可以将使用者移动无线传输到处理单元。换言之，检查的医生的运动自由不受任何在遥控器和处理单元之间作为通信连接的电缆连接的情况下的限制。

在一种合适的扩展中，遥控器具有若干用于选择各个显示模式的显示选择转换开关。根据所选择的显示模式将使用者移动转换为图像信息的虚拟运动。换言之，当事先操控了相应的显示选择转换开关时，才将使用者移动转换为所显示的图像信息的运动。由此可靠地避免了通过无意的遥控器运动和作为使用者移动的对运动的不期望的配准 (Registrierung) 引起的所显示的图像信息的错误调整。

在一种优选扩展中，遥控器至少具有一个用于医学诊断或治疗设备的遥控器的操作选择转换开关。换言之，可以借助遥控器来触发医学诊断或治疗设备的功能。例如，可以在医学信息的范围内触发对更新的图像信息的记录，以便将医学干预的进程作为图像信息变得可视。例如，在 X 射线治疗设备中，为了有针对地照射患者，可以开启或关闭治疗用的射线例如 X 射线或粒子射线。此外具有优势的是，借助遥控器来触发医学干预。在此，例如可以是注射对比剂或触发热的或电的治疗技术。可以借助遥控器来进行植入物例如近距离治疗 (Brachytherapie) 中的种子 (Seed)、或者在对心脏的干预中的支架的放置。

在一种合适的变形中，在静止位置设置用于容纳遥控器的容纳装置。该容纳装置例如被设置在被构造为患者卧榻的患者支撑装置的扶手上。该容纳装置容纳遥控器，使得医生双手都可以自由地进行干预。因为容纳装置被设置在患者支撑装置上或者在其紧邻处，所以遥控器始终处于医生可到达的范围。

容纳装置优选地具有弹性支座。换言之，还可以 (可能受限制地) 移动由容纳装置容纳的遥控器。由此对于进行简单的移动不必额外地将遥控器从其容纳装置中取出。医生在进行移动之后可以立即使其双手解放，以便继续进行医学干预。

此外，本发明的技术问题还通过一种用于显示三维医学图像信息的方法解决。为此，用遥控器借助至少一个运动敏感的传感器采集使用者移动。接着借

助通信接口将使用者移动传输到处理单元。使用者被移动理解为所显示的图像信息的虚拟运动。在此，针对用于显示三维的医学图像信息的装置的变形及其优选实施方式可以被对应地转移到所述方法。

优选地，显示模式提供了选择和至少在至少一个空间方向上移动图像信息的放大的图像片段。为此，合适地借助加速度传感器仅仅采集遥控器的平移运动。在此，例如借助被构造为按键的显示选择转换开关来进行显示模式的选择。在此，在激活显示模式的情况下首先放大地显示图像片段、优选地在显示元件上所显示的图像信息的中间图像片段。接着借助使用者移动可以移动该图像片段，直到图像片段中感兴趣的图像信息以放大的形式被显示。此外合适地的是，连续多次操控相应的显示选择转换开关可以逐渐地改变图像片段和逐渐放大所显示的图像信息。

此外，还可以优选地互相组合不同的功能。在二维的(2D)图像信息情况下遥控器在平面中的运动可以被理解为图像片段的改变，并且从平面出发的向上或向下运动被理解为所显示的图像信息的放大或者缩小。

合适地，显示模式提供了围绕至少一个空间轴转动所显示的图像信息。为此，合适地借助转动率传感器仅采集遥控器的旋转运动。按照这种方式可以将所显示的图像信息一直转动，直到在显示元件上感兴趣的图像信息可以被良好地看清并且由此可以检查。

优选地，显示模式提供了改变所显示的图像信息的比例。换言之，所显示的图像信息通过遥控器的平移运动或通过旋转运动被无级地放大或缩小地显示。

合适地，显示模式提供了改变所显示的图像信息的对比度。换言之，对比度通过遥控器的平移运动或通过遥控器的旋转运动被无级地增大或减小。在以灰度图表示的图像信息中无级地变换通常由255个灰度值组成的灰度级。以这种方式可以按照简单的方式对检查呈现最好可能的对比度。

在一种优选变形中，显示模式共同地考虑用加速度传感器和用转动率传感器的测量，用于改变所显示的图像信息。由此产生用于直观地改变图像信息的多种可能性。

在三维(3D)图像信息的情况下，在平移运动时可以移动所显示的图像片段，并且在遥控器转动时进行所显示的图像信息的放大或缩小。由此，例如遥控器的左旋可以导致所显示的图像的放大以及遥控器的右旋导致所显示的图像

信息的缩小。

如果呈现一个序列的四维(4D)图像信息,则例如又可以将平移运动转换为所显示的图像片段的改变。遥控器的旋转运动可以根据旋转方向而导致选择前面的或后面的图像信息。

在一种优选变形中,显示模式借助按照计算机鼠标方式的使用者移动,使得可以操作作为工作位计算机(Arbeitsplatzrechner)运行的处理单元。为此,合适地在遥控器上附加设置一个或多个操作按键。在操控这样的按键时,特别地仿真计算机鼠标的左键或右键的操控。通过两次直接连续操控操作键模仿如通常双击鼠标左键以开始程序等等那样的双击。换言之,借助遥控器可以遥控工作位计算机,而无需为此改变其位置。

优选地,如下构造在遥控器和计算机系统之间的通信接口:使得该通信接口关于传输到计算机系统上的控制信号与计算机鼠标的标准接口相应。以这种方式可以按照通常的方式按照完全的功能范围使用在计算机系统的操作系统上安装的软件模块。由此,不需要与相应的编程成本相关的软件模块的匹配或者程序改编。

因为为显示图像信息而设置的软件模块通常是借助计算机鼠标的操作而设置,所以优选也可以用遥控器进行软件模块的完全的操作。由此,用户通过按照计算机鼠标的方式使用遥控器,例如可以选择图像片段。接着可以用已经描述的显示模式例如通过遥控器的平移运动或通过旋转运动进行所显示的图像信息的改变。换言之,在显示元件上显示的图像信息也可以通过多个显示模式的连续切换而被改变。

合适地,在预定的时间间隔上重复地采集使用者移动并且在该时间间隔上求平均。以这种方式缓和了遥控器的突然的和剧烈的运动。

优选地,只有在使用者移动超过预定的阈值时,才将其转换为虚拟的运动。以这种方式避免了在遥控器仅仅微小偏转的情况下就立即进行所显示的图像信息的改变。

此外,本发明的技术问题还通过具有用于显示三维图像信息的装置的医学诊断或治疗设备解决。在此,针对用于显示三维的图像信息的装置的变形及其优选实施方式可以被对应地转移到所述医学诊断或治疗设备。

附图说明

下面结合附图更详细描述本发明的实施例。在附图中：

图 1 示出了用于显示三维医学图像信息的装置的示意图，

图 2 示出了所述装置的第一运行模式，

图 3 示出了所述装置的第二运行模式，以及

图 4 示出了所述装置的第三运行模式。

### 具体实施方式

图 1 示出了用于显示三维医学图像信息 1 的装置，具有被构造为计算机系统的处理单元 2 和连接到处理单元上的并且被构造为监视器的显示元件 3。装置 1 与医学成像系统 4 相关联，后者例如被构造为计算机断层成像 (CT)、正电子发射断层成像 (PET)、单光子发射计算机断层成像 (SPECT) 或者磁共振断层成像 (MRT)。借助医学成像系统 4 测量原始数据 R，该原始数据 R 由处理单元 2 所配备的计算单元 5 计算。在此，生成三维医学图像信息 B3 并且在显示元件 3 上显示。在计算机断层成像中作为原始数据 R 测量投影图像，该原始数据 R 由被构造为重建计算机的计算单元 5 转换为三维医学图像信息 B3。软件模块 7 用于准备图像信息 B3。计算机键盘 8 和计算机鼠标 9 作为操作元件分别借助接口 8'、9' 连接到处理单元 2。借助操作元件 8、9 通过控制信号 St 访问软件模块 7 并且借助用户界面准备图像信息 B3。按照这种方式可以改变在显示器 6 上显示的图像信息 B3。因此，可以放大图像信息 B3 的一个片段并且借助计算机键盘 8 的光标键或借助计算机鼠标的滚动按钮移动该片段。以类似的方式可以旋转或倾斜 (Verkippen) 所显示的图像信息 B3。

此外，为装置 1 配备了遥控器 10。遥控器 10 包括三轴的加速度传感器 11 和三轴的转动率传感器 12。借助这两个传感器 11、12 可以采集遥控器 10 的任意的使用者移动 B。为此，由加速度传感器测量位置信息 PI1 并且由转动率传感器 12 测量位置信息 PI2，并且传输到处理单元 13。此外设置了多个显示选择转换开关 14，其开关状态 S1 被传输到处理单元 13。另外设置了多个操作选择转换开关 15，其开关状态 S2 同样被传输到处理单元 13。根据显示选择转换开关 14 的开关状态 S1，处理单元 13 准备由传感器 11、12 测量的位置信息 PI1、PI2 并且借助通信接口 16 将其作为位置信息 PI 传输到处理单元 2。位置信息 PI 与图像信息 B3 一起由软件模块 7 如下计算：将使用者移动 B 理解为所显示的图像信息 B3 (PI) 的虚拟运动。换言之，根据所显示的图像信息 B3 (PI) 理

解遥控器 10 的任意的使用者移动 B。这可以非常直观地改变所显示的图像信息 B3 (PI)。

操作选择转换开关 15 的开关状态 S2 借助处理单元 13 经过通信接口 16 被传输到处理单元 2 并且从那里被传输到医学成像系统 4。根据医学成像系统 4 的不同的实现, 借助遥控器 10 可以远程控制设备功能。例如, 借助遥控器 10 在计算机断层成像中可以触发用于产生新的原始数据 R 以及由此产生新的三维医学图像信息 B3 的扫描。如果医学成像系统是医学治疗装置的部分, 则可以借助操作选择转换开关 15 开启或者关闭用于放射疗法的微粒辐射。

医学成像系统 4 配备有用于遥控器 10 的容纳装置 17。容纳装置 17 具有弹性支座 18, 例如弹簧臂 (Federarm) 等等, 遥控器 10 借助该支座被固定在成像系统 4 的组件上。在此, 例如是在图 1 中未示出的患者卧榻的扶手。

总之, 主治医师相应地从任意的的位置既可以触发成像系统 4 的功能, 也可以对所显示的图像信息 B3 (PI) 进行改变。由此, 主治医师不必赶到处理单元 2 处并且借助计算机键盘 8 或计算机鼠标 9 在那里来触发功能。而是他可以集中精神于其医生的任务例如进行医学的干预。根据需要可以触发借助医学成像系统 4 用于产生新的图像信息 B3 的新的测量, 以便监控医学干预的进程。借助遥控器修改在显示器 6 上所显示的图像信息 B3 (PI), 以便可得到最佳的检查结果。接着根据该检查结果继续进行医学的干预。

如果不需要遥控器 10, 则将其置于容纳装置 17 中。借助容纳装置 17 的弹性支座 18, 主治医师可以进行使用者移动 B, 其被转换成图像信息 B3 (PI) 的虚拟运动, 即使也许是受限的移动可能性。

图 2 示出了显示元件 3 的显示器 6, 在该显示器 6 上示出了用户界面 19。该用户界面 19 具有菜单列表 20 和若干按键 21, 借助其可以访问软件模块 7 的功能。在显示元件 3 的位置上的用户界面 19 的操作借助计算机键盘 8 或计算机鼠标 9, 通过访问菜单列表 20 或按键 21 来进行。由此可以从计算机键盘 8 或计算机鼠标 9 的位置改变所显示的图像信息。

借助遥控器 10 进行对软件模块 7 的访问。遥控器 10 具有用于显示目前选择的运行模式的指示区域 22。通过操控显示选择转换开关 14a 可以选择第一显示模式并且在显示器 6 上显示图像信息 B3 的片段 23。此时, 借助遥控器 10 的使用者移动 B 一直移动片段, 直到所显示的图像信息 B3 (PI) 显示期望的片段 23。换言之, 第一显示模式具有如下功能: 仅仅分析借助加速度传感器 11 所测



量的遥控器 10 在所有三个空间方向  $x$ 、 $y$ 、 $z$  上的平移运动并且将其转换为片段 23 在所有三个空间方向  $x$ 、 $y$ 、 $z$  上的移动以显示图像信息 B3 (PI)。如果多次连续操纵了显示选择转换开关 14a, 则片段 23 被逐步地放大。借助另一个显示选择转换开关 14b 又可以建立最初显示的图像信息 B3 并且再次退出第一显示模式。

图 3 如图 2 那样示出了显示元件 3 的显示器 6 和作为所显示的三维图像信息 B3 的心脏。借助遥控器 10 的显示选择转换开关 14b 可以选择遥控器 10 的第二显示模式。在所选择的第二显示模式中, 仅仅分析遥控器 10 的旋转运动以及由此作为使用者移动 B 的遥控器 10 的转动率传感器 12 的测量信号, 并且将其转换为所显示的图像信息 B3 (PI) 的转动或者说旋转。以这种方式, 可以作为使用者移动 B 采集围绕空间轴  $x$ 、 $y$ 、 $z$  的任意的转动或者说旋转。换言之, 随着遥控器 10 在所有三个空间方向上的转动, 图像信息 B3 一直转动, 直到用户感兴趣的图像信息 B3 (PI) 在显示器 6 上被显示。通过操控显示选择转换开关 14c 又可以显示最初的图像信息 B3 并且退出遥控器 10 的第二运行模式。

图 4 示出了处在通过操控显示选择转换开关 14d 所选择的第三显示模式之下的显示器 6。现在, 在显示器 6 上不再看得见图像信息 B3。而是此时显示鼠标光标 24, 借助该鼠标光标可以通过遥控器 10 在用户界面 19 上选择任意的程序功能。换言之, 该第三显示模式对应于按照计算机鼠标 9 的方式操作用户界面 19。为此, 如下处理利用加速度传感器 11 所测量的位置信息 PI1: 仅仅分析作为使用者移动 B 的在两个空间轴  $x$ 、 $y$  的方向上的运动并且将其转换为位置信息 PI。而对鼠标光标 24 的运动不考虑第三空间方向。在所示出的情况下所显示的图像信息 B3 (PI) 的虚拟运动对应于鼠标光标 24 的运动。此外, 设置了两个操作按键 25, 其在功能上对应于鼠标左键以及右键。由此遥控器 10 可以模仿计算机鼠标的所有功能。

通过再次操控显示选择转换开关 14d 可以再次退出第三显示模式。



图 1



图 2

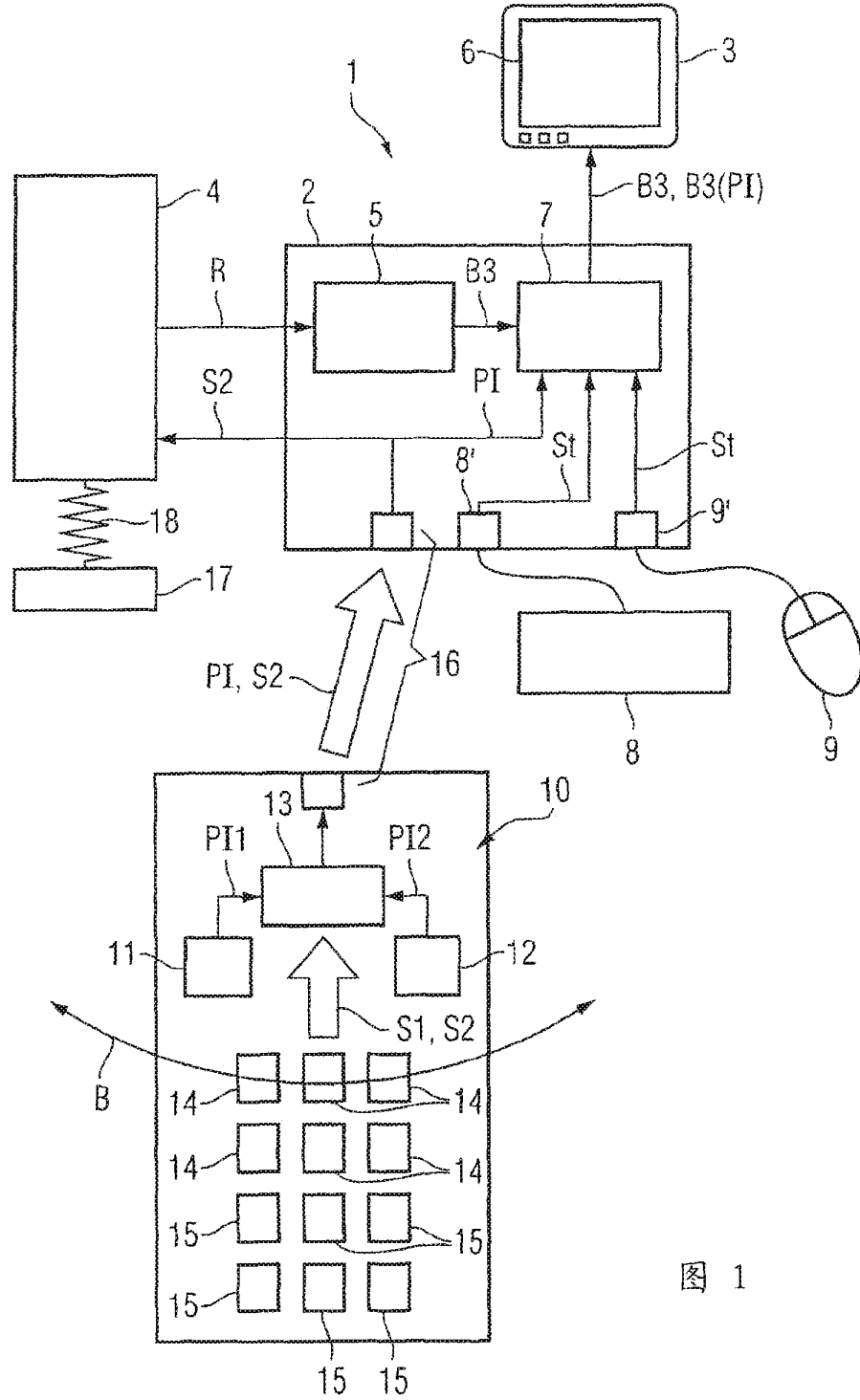

B3, B3(PI)

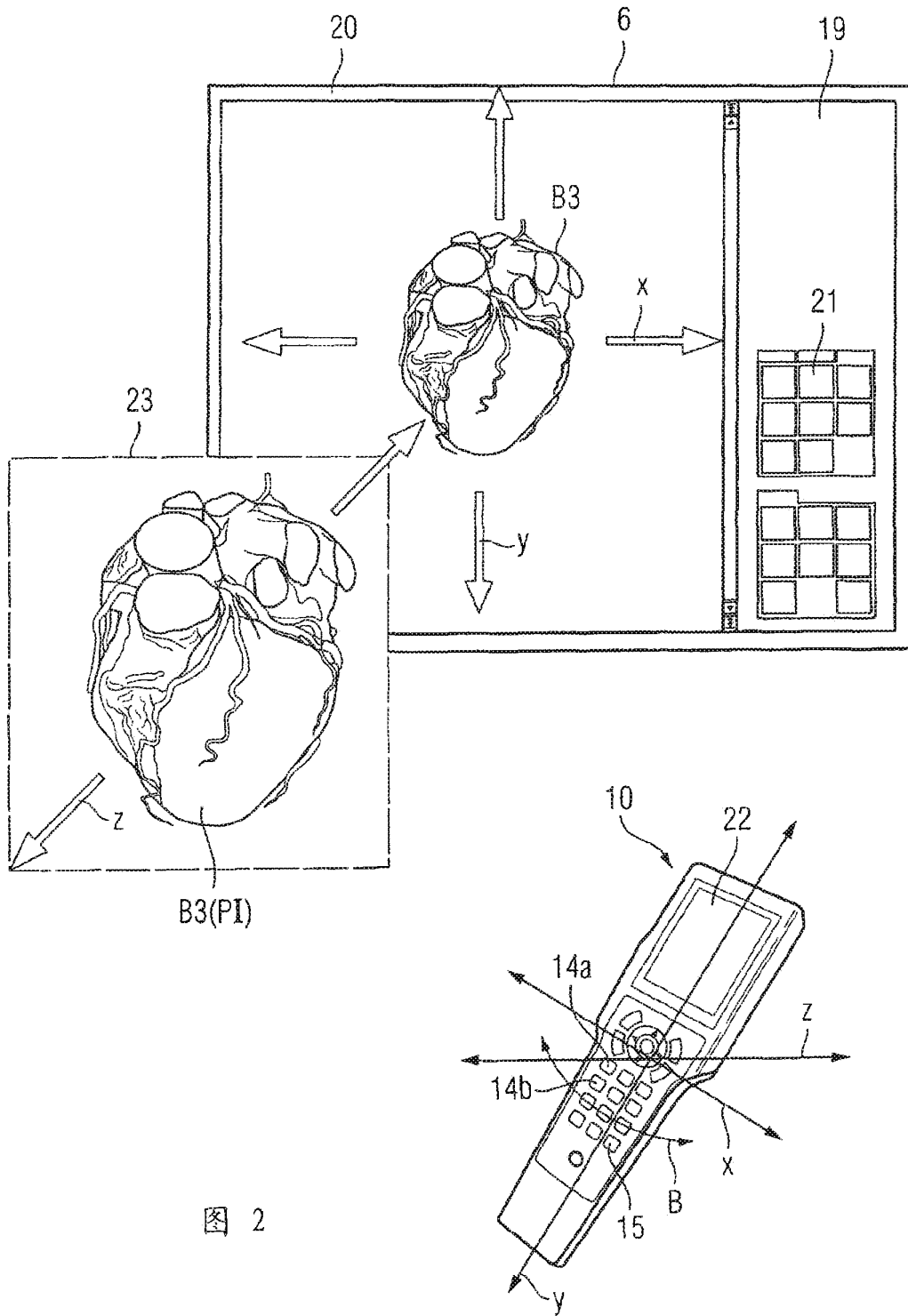
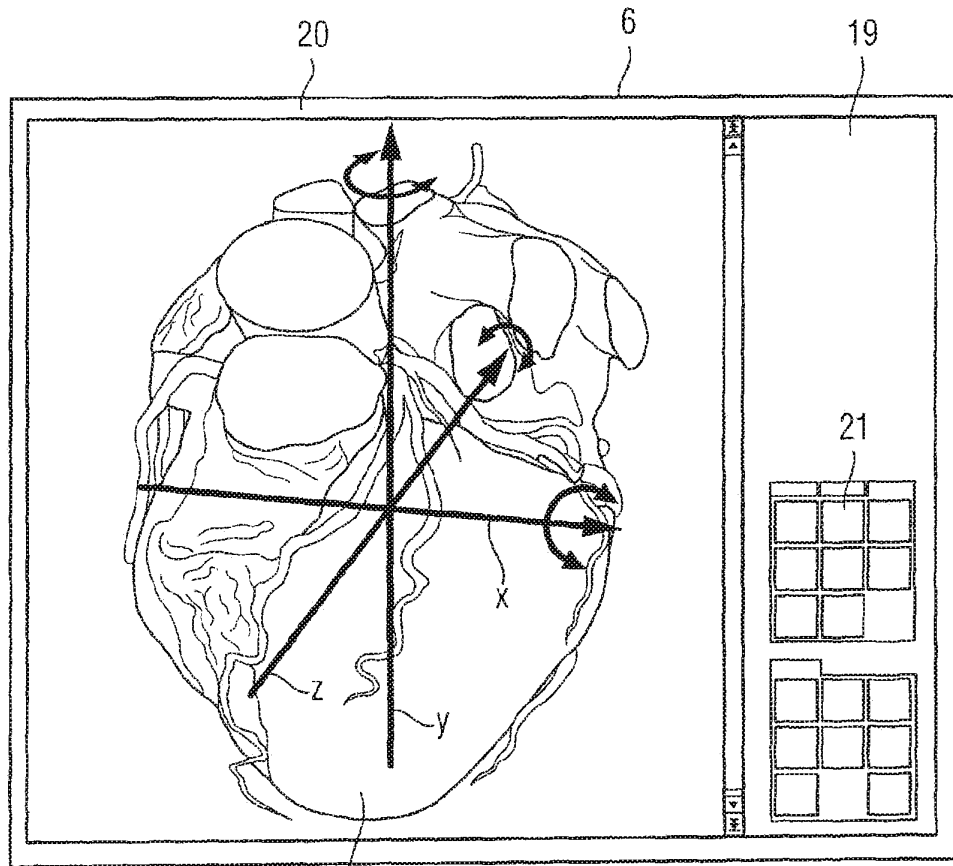

图 3



图 4

PATENT COOPERATION TREATY

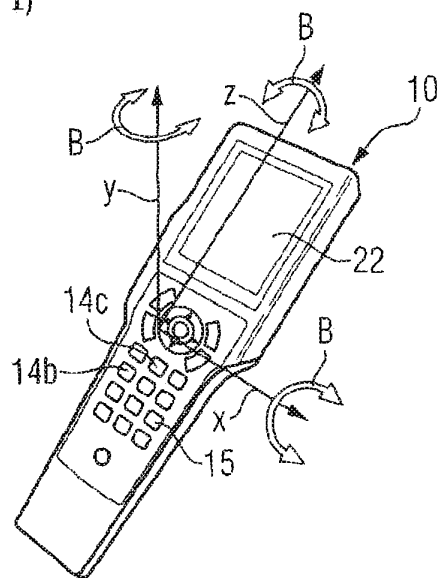
PCT

INTERNATIONAL SEARCH REPORT

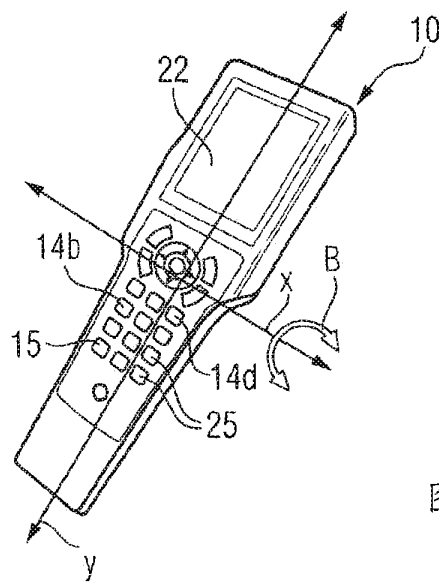
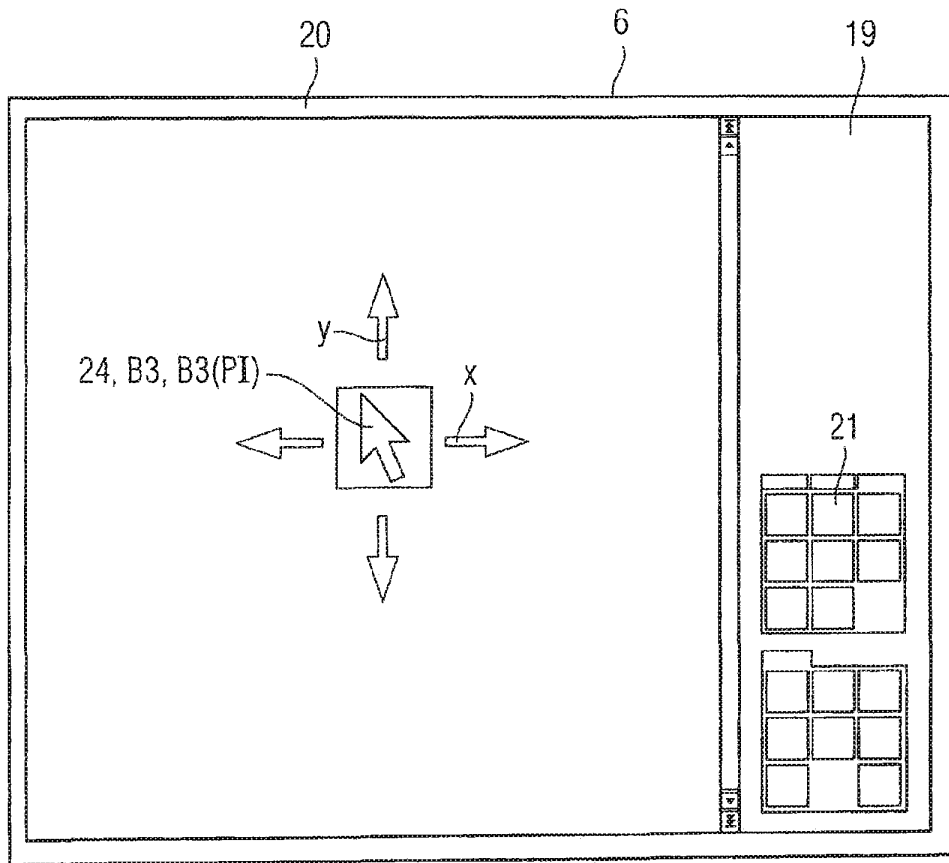
(PCT Article 18 and Rules 43 and 44)

Applicant's or agent's file reference <b>P2635PC00</b>	<b>FOR FURTHER ACTION</b>	see Form PCT/ISA/220 as well as, where applicable, item 5 below.
International application No. <b>PCT/DK2011/050461</b>	International filing date ( <i>day/month/year</i> ) <b>05/12/2011</b>	(Earliest) Priority Date ( <i>day/month/year</i> ) <b>06/12/2010</b>
Applicant <b>3SHAPE A/S</b>		

This international search report has been prepared by this International Searching Authority and is transmitted to the applicant according to Article 18. A copy is being transmitted to the International Bureau.

This international search report consists of a total of 6 sheets.

It is also accompanied by a copy of each prior art document cited in this report.

1. **Basis of the report**

a. With regard to the **language**, the international search was carried out on the basis of:

the international application in the language in which it was filed.

a translation of the international application into \_\_\_\_\_ which is the language of a translation furnished for the purposes of international search (Rules 12.3(a) and 23.1(b)).

b.  This international search report has been established taking into account the **rectification of an obvious mistake** authorized by or notified to this Authority under Rule 91 (Rule 43.6bis(a)).

c.  With regard to any **nucleotide and/or amino acid sequence** disclosed in the international application, see Box No. I.

2.  **Certain claims were found unsearchable** (see Box No. II).

3.  **Unity of invention is lacking** (see Box No. III).

4. With regard to the **title**,

the text is approved as submitted by the applicant.

the text has been established by this Authority to read as follows:

5. With regard to the **abstract**,

the text is approved as submitted by the applicant.

the text has been established, according to Rule 38.2, by this Authority as it appears in Box No. IV. The applicant may, within one month from the date of mailing of this international search report, submit comments to this Authority.

6. With regard to the **drawings**,

a. the figure of the **drawings** to be published with the abstract is Figure No. 2a

as suggested by the applicant.

as selected by this Authority, because the applicant failed to suggest a figure.

as selected by this Authority, because this figure better characterizes the invention.

b.  none of the figures is to be published with the abstract.

INTERNATIONAL SEARCH REPORT

International application No.  
PCT/DK2011/050461

**Box No. II Observations where certain claims were found unsearchable (Continuation of item 2 of first sheet)**

This international search report has not been established in respect of certain claims under Article 17(2)(a) for the following reasons:

1.  Claims Nos.:  
because they relate to subject matter not required to be searched by this Authority, namely:
  
2.  Claims Nos.:  
because they relate to parts of the international application that do not comply with the prescribed requirements to such an extent that no meaningful international search can be carried out, specifically:
  
3.  Claims Nos.:  
because they are dependent claims and are not drafted in accordance with the second and third sentences of Rule 6.4(a).

**Box No. III Observations where unity of invention is lacking (Continuation of item 3 of first sheet)**

This International Searching Authority found multiple inventions in this international application, as follows:  
**See extra sheet**

1.  As all required additional search fees were timely paid by the applicant, this international search report covers all searchable claims.
2.  As all searchable claims could be searched without effort justifying additional fees, this Authority did not invite payment of additional fees.
3.  As only some of the required additional search fees were timely paid by the applicant, this international search report covers only those claims for which fees were paid, specifically claims Nos.:
4.  No required additional search fees were timely paid by the applicant. Consequently, this international search report is restricted to the invention first mentioned in the claims; it is covered by claims Nos.:  
**1-34, 38-52**

- Remark on Protest**
- The additional search fees were accompanied by the applicant's protest and, where applicable, the payment of a protest fee.
  - The additional search fees were accompanied by the applicant's protest but the applicable protest fee was not paid within the time limit specified in the invitation.
  - No protest accompanied the payment of additional search fees.

INTERNATIONAL SEARCH REPORT

International application No.

PCT/DK2011/050461

Box No. IV Text of the abstract (Continuation of item 5 of the first sheet)

Disclosed is a system comprising a handheld device (100) and at least one display (101), where the handheld device (100) is adapted for performing at least one action in a physical 3D environment. The actions include measuring, modifying, manipulating, recording, touching, sensing, scanning, moving, transforming, cutting, welding, chemically treating, cleaning. The display (101) is adapted for visually representing the physical 3D environment, and where the handheld device (100) is adapted for remotely controlling the view with which the 3D environment is represented on the display (101).



## INTERNATIONAL SEARCH REPORT

International application No.

PCT/DK2011/050461

A. CLASSIFICATION OF SUBJECT MATTER G01B 11/24 (2006.01), A61C 13/00 (2006.01)		
According to International Patent Classification (IPC) or to both national classification and IPC		
B. FIELDS SEARCHED		
Minimum documentation searched (classification system followed by classification symbols) IPC/EC: G06F, G01B, A61C; ICO: K63F; FT:4C061/CC		
Documentation searched other than minimum documentation to the extent that such documents are included in the fields searched DK, SE, FI, NO (IPC classes as above)		
Electronic data base consulted during the international search (name of data base and, where practicable, search terms used) EPODOC, WPI, TXTE		
C. DOCUMENTS CONSIDERED TO BE RELEVANT		
Category*	Citation of document, with indication, where appropriate, of the relevant passages	Relevant to claim No.
X; A	US 2009/0217207 A1 (KAGERMEIER et al) 2009.08.27, entire application, in particular sections [0007], [0009], [0012]-[0013], [0019]-[0020], [0023], [0035]-[0039], fig. 1-4	1-33, 38-48, 50-52; 34, 49
X; A	WO 2004/066615 A1 (NOKIA CORPORATION) 2004.08.05, page 3, line 16 to page 4, line 2, page 25, line 12, to page 26, line 5.	1, 3-14, 16-33, 38-48, 50-52; 2, 15, 34, 49
X; A	US 2003/0158482 A1 (POLAND et al) 2003.08.21, sections [0032], [0034], figs 6, 8.	1-11, 15-17, 26-33, 38-39, 46, 48, 50-52; 12-14, 18-25, 34, 40, 41-45, 47
A	US 2009/0061381 A1 (DURBIN et al) 2009.03.05, sections [0018]-[0019], [0024]	1-33, 38-52
<input type="checkbox"/> Further documents are listed in the continuation of Box C. <input checked="" type="checkbox"/> See patent family annex.		
* Special categories of cited documents: "A" document defining the general state of the art which is not considered to be of particular relevance "E" earlier application or patent but published on or after the international filing date "L" document which may throw doubts on priority claim(s) or which is cited to establish the publication date of another citation or other special reason (as specified) "O" document referring to an oral disclosure, use, exhibition or other means "P" document published prior to the international filing date but later than the priority date claimed "T" later document published after the international filing date or priority date and not in conflict with the application but cited to understand the principle or theory underlying the invention "X" document of particular relevance; the claimed invention cannot be considered novel or cannot be considered to involve an inventive step when the document is taken alone "Y" document of particular relevance; the claimed invention cannot be considered to involve an inventive step when the document is combined with one or more other such documents, such combination being obvious to a person skilled in the art "&" document member of the same patent family		
Date of the actual completion of the international search 17/02/2012		Date of mailing of the international search report 22/02/2012
Name and mailing address of the ISA/ Nordic Patent Institute, Helgeshøj Allé 81, DK-2630 Taastrup, Denmark. Facsimile No. +45 43 50 80 08		Authorized officer Lennart Bitsch Telephone No. +45 43 50 8244

INTERNATIONAL SEARCH REPORT  
Information on patent family members

International application No.  
PCT/DK2011/050461

Patent document cited in search report	Publication date	Patent family member(s)	Publication date
US2009217207 A1	20090827	CN101513350 A DE102008010717 A1	20090826 20090827
WO2004066615 A1	20040805	US2006146009 A1 EP1588552 A1 AU2003303787 A1	20060706 20051026 20040813
US2003158482 A1	20030821	JP2005517515 A WO03071306 A1 EP1488253 A1 EP1488253 B1 DE60308495T T2 CN1636151 A CN100340867C C AU2003247479 A1 AT340365T T US7141020 B2	20050616 20030828 20041222 20060920 20070606 20050706 20071003 20030909 20061015 20061128
US2009061381 A1	20090305	WO2009033108 A1 KR20100066538 A JP2010538302 A EP2185891 A1 CA2698525 A1	20090312 20100617 20101209 20100519 20090312

Continuation of Box no. III

This International Searching Authority found multiple inventions.

US 2009/0217207 A1 (KAGERMEIER et al) 2009.08.27 describes a system comprising a handheld device (10) and at least one display (3, 22), where the handheld device is adapted for switching between

-performing at least one action in a physical 3D environment, where the at least one display is adapted for visually representing the physical 3D environment ([0013], [0037]), and  
-remotely controlling the view with which the 3D environment is represented on the display ([0007], [0036], [0039])

The general concept described in the independent claim 1 is known from US 2009/0217207, and the application does therefore describe 4 inventions

A: Claims 2-34, 38-52 describe modifications of a system, a method, and a computer program product comprising a handheld device for performing at least one action, and for remotely controlling the view, and wherein the handheld device is an intra-oral 3D scanner

B: Claim 35 describes a system wherein the handheld device of claim 1 is a surgical instrument

C: Claim 36 describes a system wherein the handheld device of claim 1 is a mechanical tool

D: Claim 37 describes a system wherein the handheld device of claim 1 is an in-ear 3D scanner

There is no Single General Inventive Concept among the inventions A, B, C and D, and there is, therefore, not a technical relationship to link the invention as defined in Rules 13.1 and 13.2 PCT.

## Electronic Patent Application Fee Transmittal

<b>Application Number:</b>	16526281			
<b>Filing Date:</b>	30-Jul-2019			
<b>Title of Invention:</b>	SYSTEM WITH 3D USER INTERFACE INTEGRATION			
<b>First Named Inventor/Applicant Name:</b>	Henrik ÖJELUND			
<b>Filer:</b>	Stephany Gale Small/Ebony Jennings			
<b>Attorney Docket Number:</b>	0079124-000266			
Filed as Large Entity				
<b>Filing Fees for Utility under 35 USC 111(a)</b>				
<b>Description</b>	<b>Fee Code</b>	<b>Quantity</b>	<b>Amount</b>	<b>Sub-Total in USD(\$)</b>
<b>Basic Filing:</b>				
<b>Pages:</b>				
<b>Claims:</b>				
CLAIMS IN EXCESS OF 20	1202	5	100	500
<b>Miscellaneous-Filing:</b>				
<b>Petition:</b>				
<b>Patent-Appeals-and-Interference:</b>				
<b>Post-Allowance-and-Post-Issuance:</b>				

Description	Fee Code	Quantity	Amount	Sub-Total in USD(\$)
<b>Extension-of-Time:</b>				
<b>Miscellaneous:</b>				
<b>Total in USD (\$)</b>				<b>500</b>

## Electronic Acknowledgement Receipt

<b>EFS ID:</b>	37581414
<b>Application Number:</b>	16526281
<b>International Application Number:</b>	
<b>Confirmation Number:</b>	9657
<b>Title of Invention:</b>	SYSTEM WITH 3D USER INTERFACE INTEGRATION
<b>First Named Inventor/Applicant Name:</b>	Henrik ÖJELUND
<b>Customer Number:</b>	21839
<b>Filer:</b>	Stephany Gale Small/Ebony Jennings
<b>Filer Authorized By:</b>	Stephany Gale Small
<b>Attorney Docket Number:</b>	0079124-000266
<b>Receipt Date:</b>	28-OCT-2019
<b>Filing Date:</b>	30-JUL-2019
<b>Time Stamp:</b>	16:36:11
<b>Application Type:</b>	Utility under 35 USC 111(a)

### Payment information:

Submitted with Payment	yes
Payment Type	CARD
Payment was successfully received in RAM	\$500
RAM confirmation Number	E20190RG37193919
Deposit Account	024800
Authorized User	Ebony Jennings
The Director of the USPTO is hereby authorized to charge indicated fees and credit any overpayment as follows: 37 CFR 1.21 (Miscellaneous fees and charges)	

<b>File Listing:</b>					
Document Number	Document Description	File Name	File Size(Bytes)/ Message Digest	Multi Part /.zip	Pages (if appl.)
1		20191028_Second_Preliminary_Amendment.pdf	205602 c437c8199a39fc8e0b204327df8a33023fe0f2c3	yes	15
<b>Multipart Description/PDF files in .zip description</b>					
		Document Description	Start	End	
		Preliminary Amendment	1	1	
		Claims	2	11	
		Applicant Arguments/Remarks Made in an Amendment	12	15	
<b>Warnings:</b>					
<b>Information:</b>					
2		20191028_First_IDS.pdf	177283 95673e060406983d0c1ea3cb3a8cb4e91c711c0c	yes	5
<b>Multipart Description/PDF files in .zip description</b>					
		Document Description	Start	End	
		Transmittal Letter	1	1	
		Information Disclosure Statement (IDS) Form (SB08)	2	5	
<b>Warnings:</b>					
<b>Information:</b>					
3	Foreign Reference	40_WO2010064156A1.pdf	201693 5f60d52e56f8590b5b6b3742c2f69fe78ee23fb	no	26
<b>Warnings:</b>					
<b>Information:</b>					

4	Foreign Reference	41_EP2200332A1.pdf	709649	no	12
			7fcb1075b575f144c106e393d5f50a232f27832c		
<b>Warnings:</b>					
<b>Information:</b>					
5	Foreign Reference	42_WO2000008415A1.pdf	1144345	no	29
			085bac9c44ea0ba5f95740980917c64945cb7427		
<b>Warnings:</b>					
<b>Information:</b>					
6	Foreign Reference	43_WO2010145669A1.pdf	1696576	no	97
			89beba8f4c42ac55281e2a565e5fe6cc10e8d451		
<b>Warnings:</b>					
<b>Information:</b>					
7	Foreign Reference	44_WO2011120526A1.pdf	3376124	no	80
			2b79bf3ca484218e6632d17dfa5318b88aa09ad7		
<b>Warnings:</b>					
<b>Information:</b>					
8	Foreign Reference	45_WO2004066615A1.pdf	2328477	no	54
			1f2f3e7be7e2e78e0f87c6001c8c51f64d57869d		
<b>Warnings:</b>					
<b>Information:</b>					
9	Foreign Reference	47_WO2009089126A1.pdf	403936	no	48
			32914dc998beaa682eb9b06b435363204b6ea84e		
<b>Warnings:</b>					
<b>Information:</b>					
10	Foreign Reference	48_WO2001011193A1.pdf	752869	no	16
			800cc08cc47d9e25a28a2859465cb606c3478425		
<b>Warnings:</b>					
<b>Information:</b>					



11	Foreign Reference	49_WO2007084727A1.pdf	938036	no	138
			a6196c3a20f9a7ff4a0c870ef72d506d726842b1		
<b>Warnings:</b>					
<b>Information:</b>					
12	Foreign Reference	50_WO2013010910A1.pdf	8074931	no	93
			61daab36f53f956837e4d98492ce5c4ed4c8cfc1		
<b>Warnings:</b>					
<b>Information:</b>					
13	Foreign Reference	46_CN101513350A.pdf	17832409	no	18
			f98b77540a5d0103e756381b4d1dfdcb81d7db4		
<b>Warnings:</b>					
<b>Information:</b>					
14	Non Patent Literature	51_IPR_Petition.pdf	743365	no	67
			a21756d43f566eb9ab8b02b7bae2e5889abf12e		
<b>Warnings:</b>					
<b>Information:</b>					
15	Non Patent Literature	52_Patent_Owner_Preliminary_Response_IPR2018-00197.pdf	378772	no	66
			19ff34b7ea4b20631b09a2be2e2db5455a1784b4		
<b>Warnings:</b>					
<b>Information:</b>					
16	Non Patent Literature	53_Institution_Decision_IPR2018-00197.pdf	812355	no	32
			c346bc8df456ef1a800e3e009cc748df4e50b3ea		
<b>Warnings:</b>					
<b>Information:</b>					
17	Non Patent Literature	54_Patent_Owner_Response_IPR2018-00197.pdf	527853	no	57
			b4b5babddd3c87a0c5db31038b91e9840cb5a48c5		
<b>Warnings:</b>					
<b>Information:</b>					

18	Non Patent Literature	55_Petitioners_Reply.pdf	820229	no	35
			1d465a0f1ffb7fa72e2c750492e5988b834be8ef		
<b>Warnings:</b>					
<b>Information:</b>					
19	Non Patent Literature	56_Petitioners_Demonstratives.pdf	12564970	no	30
			ddc3132ff60e3200a7871314c2c9a7dbff63a81b		
<b>Warnings:</b>					
<b>Information:</b>					
20	Non Patent Literature	57_Patent_Owner_Submission_of_Demonstratives_for_Oral_Argument.pdf	5767006	no	42
			07931d1d139aeba02b42cf26e05f5b25bbe4225a		
<b>Warnings:</b>					
<b>Information:</b>					
21	Non Patent Literature	58_FINAL_Petition_IPR2018-00198.pdf	1071431	no	77
			a7cedf6187de0529baaa112a2b54bb3fa67b4471		
<b>Warnings:</b>					
<b>Information:</b>					
22	Non Patent Literature	59_Patent_Owner_Preliminary_Response_IPR2018-00198.pdf	465927	no	66
			410a702047b19f577d64f2669d42fc4b45457cce		
<b>Warnings:</b>					
<b>Information:</b>					
23	Non Patent Literature	60_Decision_Denying_Institution_IPR2018-00198.pdf	539473	no	15
			9b01f21fcc12309d35fad350bbab3ed0769dfa42		
<b>Warnings:</b>					
<b>Information:</b>					
24	Non Patent Literature	61_Petitioners_Rehearing_Request_IPR2018-00198.pdf	362339	no	14
			6cbe4d89b5318d37014f35328fcd597562875752		
<b>Warnings:</b>					
<b>Information:</b>					

25	Non Patent Literature	62_Decision_Denying_Rehearing_Request_IPR2018-00198.pdf	179534	no	8
			fb1775eeacf7bec76382b98f6dad5c77d3206388		
<b>Warnings:</b>					
<b>Information:</b>					
26	Non Patent Literature	64_Exhibit_1003_Bajaj_Declaration_IPR2018_00197.pdf	2108871	no	127
			8bcc6d6628c924b9a8ff1f5fc60308a75c5e4f7c		
<b>Warnings:</b>					
<b>Information:</b>					
27	Non Patent Literature	65_Exhibit_1003_Bajaj_Declaration_IPR2018-00198.pdf	2202507	no	123
			9f40e9f0d184065c887d9d1a639f7e8536e77468		
<b>Warnings:</b>					
<b>Information:</b>					
28	Non Patent Literature	66_Exhibit_1004_Bajaj_CV.pdf	641527	no	49
			34a2c45e4a38ea182f5d796ce57341aeb025850		
<b>Warnings:</b>					
<b>Information:</b>					
29	Non Patent Literature	67_Exhibit_1016_Karatas_and_Toy.pdf	816079	no	9
			cd0347b06483d6bb3615d9e98b20792a791f9711		
<b>Warnings:</b>					
<b>Information:</b>					
30	Non Patent Literature	68_Exhibit_1017_Broadbent.pdf	4293193	no	22
			a043295499014deb172449681f5b660afd50ad7c		
<b>Warnings:</b>					
<b>Information:</b>					
31	Non Patent Literature	69_Exhibit_1018_Birnbaum_and_Aaronson.pdf	248922	no	16
			840b5a89195b7b4a62787e84906f24b934f64f32		
<b>Warnings:</b>					
<b>Information:</b>					

32	Non Patent Literature	70_Exhibit_1022_Ireland_et_al.pdf	324666	no	6
			6db93b4127f4a2c5d71d1887dbb8850066579015		
<b>Warnings:</b>					
<b>Information:</b>					
33	Non Patent Literature	71_Exhibit_1023_Hajeer.pdf	1413403	no	9
			5df568ee8b218c4de7d24e291d332266c16e734d0		
<b>Warnings:</b>					
<b>Information:</b>					
34	Non Patent Literature	72_Exhibit_1029_Bornik_et_al.pdf	977825	no	8
			242a4b1dfde865275ec56d14a5db01711b68a9f1		
<b>Warnings:</b>					
<b>Information:</b>					
35	Non Patent Literature	73_Exhibit_1036_Giammanco_et_al.pdf	1189130	no	8
			4dc6c48aff6b64e22faea70887435be7b9f5d2a9		
<b>Warnings:</b>					
<b>Information:</b>					
36	Non Patent Literature	74_Exhibit_1038_Bowman_Exc erpt.pdf	6201392	no	9
			b451eb4ad411b684a57f6ff4913477aacb4bb2a7		
<b>Warnings:</b>					
<b>Information:</b>					
37	Non Patent Literature	76_Exhibit_2002_IPR2018-00197.pdf	7114650	no	6
			dbaec732df9a4cc5f52079700dc6595f6f713931		
<b>Warnings:</b>					
<b>Information:</b>					
38	Non Patent Literature	77_Exhibit_2003_IPR2018-00197.pdf	1142836	no	9
			128dda99f109948fe146c3791d7724c015ae0166		
<b>Warnings:</b>					
<b>Information:</b>					

39	Non Patent Literature	78_Exhibit_2004_IPR2018-00197.pdf	894645 beb8b450fa9d3c5f93e0edf27c0ec199d338097e	no	9
<b>Warnings:</b>					
<b>Information:</b>					
40	Non Patent Literature	80_Exhibit_2006_SonoDEX_Serara_publication.pdf	392942 0f10c72294597e6177fd2f72bde441ee5a253b5f	no	6
<b>Warnings:</b>					
<b>Information:</b>					
41	Non Patent Literature	81_Exhibit_2008_Bajaj_depo_t_ranscript_7-25-18_with_errata.pdf	2102793 a2fd9cd88d32e5e7d1d60f4a1379a8c4966b941d	no	142
<b>Warnings:</b>					
<b>Information:</b>					
42	Non Patent Literature	82_Exhibit_2009_Mackinlay.pdf	1086322 923e44b758e50611e2dd09438620477c16ddf106	no	46
<b>Warnings:</b>					
<b>Information:</b>					
43	Non Patent Literature	83_Exhibit_2010_Buxton_2009.pdf	275837 ebc13c018c858cba410ae150440991e6384bac6d	no	16
<b>Warnings:</b>					
<b>Information:</b>					
44	Non Patent Literature	84_Exhibit_2011_Balakrishnan_Declaration.pdf	542906 5861e42a0aaa0839654af4b8ed1caf28999ce435	no	55
<b>Warnings:</b>					
<b>Information:</b>					
45	Non Patent Literature	85_Exhibit_2012_Ravin_Balakrishnan_CV.pdf	387878 7fff2b2e06cd0e8e2d5c000478944a774b7b6458	no	30
<b>Warnings:</b>					
<b>Information:</b>					

46	Non Patent Literature	86_Exhibit_2013_3D_User_Interfaces.pdf	10261869	no	20
			6227715732910fadfe46ee18f64659b51dbec749		
<b>Warnings:</b>					
<b>Information:</b>					
47	Non Patent Literature	88_WO2012076013-PCTDK2011050461-ISR-20120222.pdf	234856	no	6
			91c8c88bc31403d58f5946c2be474189af133a19		
<b>Warnings:</b>					
<b>Information:</b>					
48	Non Patent Literature	87_Exhibit_2014_VR_Book.pdf	331227	no	4
			4bddd8b316d0801dc8e76908f9fa6078c2bfff33ff		
<b>Warnings:</b>					
<b>Information:</b>					
49	Non Patent Literature	89_C_Graetzel_et_al.pdf	22788648	no	19
			8e839e65d763bfff9f83e787fd010e2141a4484d0		
<b>Warnings:</b>					
<b>Information:</b>					
50	Non Patent Literature	90_S_Vogt_et_al.pdf	905196	no	7
			4786a139ec934ddb4d52e7223fd0688374f35aa9		
<b>Warnings:</b>					
<b>Information:</b>					
51	Non Patent Literature	91_Xia_et_al.pdf	1673026	no	11
			3ba978b9f596f12cc286502aa36479b41866e006		
<b>Warnings:</b>					
<b>Information:</b>					
52	Non Patent Literature	92_CN2011800669566_First_Office_Action.pdf	545334	no	13
			a9e80f66df6ec2a5229f8e05a51e89f2ad88ef25		
<b>Warnings:</b>					
<b>Information:</b>					

53	Non Patent Literature	93_CN2011800669566_Second _Office_Action.pdf	1361538	no	27
			6ab76a3421661cfe0a9953fd673a4b03895f7e43		
<b>Warnings:</b>					
<b>Information:</b>					
54	Non Patent Literature	94_Exhibit_1037_Balakrishnan _Depo_Transcript.pdf	308682	no	101
			1c64509184e745509bd5f9d6aed66abd1af7f984		
<b>Warnings:</b>					
<b>Information:</b>					
55	Non Patent Literature	95_Hearing_Transcript_IPR201 8-00197.pdf	323533	no	67
			27c3a268c63dd8bc62ede02dd41af23e413841c8		
<b>Warnings:</b>					
<b>Information:</b>					
56	Non Patent Literature	96_Final_Written_Decision- Termination_Decision_Docum ent_IPR2018-00197.pdf	1309431	no	64
			2b4ccf1e0b64b708a87809a65445b4c1daafe9b		
<b>Warnings:</b>					
<b>Information:</b>					
57	Non Patent Literature	75_Exhibit_1038_EP2649409_F ile_History_IPR2018-00198.pdf	17204749	no	180
			1a6c9cd7cbaef5cd8c5b806dedd6a4484ee4e995		
<b>Warnings:</b>					
<b>Information:</b>					
58	Fee Worksheet (SB06)	fee-info.pdf	30651	no	2
			ec89c34c9ac64c9eee97b2a4a83d41d5512eadd9		
<b>Warnings:</b>					
<b>Information:</b>					
<b>Total Files Size (in bytes):</b>			153712248		

**This Acknowledgement Receipt evidences receipt on the noted date by the USPTO of the indicated documents, characterized by the applicant, and including page counts, where applicable. It serves as evidence of receipt similar to a Post Card, as described in MPEP 503.**

**New Applications Under 35 U.S.C. 111**

**If a new application is being filed and the application includes the necessary components for a filing date (see 37 CFR 1.53(b)-(d) and MPEP 506), a Filing Receipt (37 CFR 1.54) will be issued in due course and the date shown on this Acknowledgement Receipt will establish the filing date of the application.**

**National Stage of an International Application under 35 U.S.C. 371**

**If a timely submission to enter the national stage of an international application is compliant with the conditions of 35 U.S.C. 371 and other applicable requirements a Form PCT/DO/EO/903 indicating acceptance of the application as a national stage submission under 35 U.S.C. 371 will be issued in addition to the Filing Receipt, in due course.**

**New International Application Filed with the USPTO as a Receiving Office**

**If a new international application is being filed and the international application includes the necessary components for an international filing date (see PCT Article 11 and MPEP 1810), a Notification of the International Application Number and of the International Filing Date (Form PCT/RO/105) will be issued in due course, subject to prescriptions concerning national security, and the date shown on this Acknowledgement Receipt will establish the international filing date of the application.**



## Electronic Acknowledgement Receipt

<b>EFS ID:</b>	37582196
<b>Application Number:</b>	16526281
<b>International Application Number:</b>	
<b>Confirmation Number:</b>	9657
<b>Title of Invention:</b>	SYSTEM WITH 3D USER INTERFACE INTEGRATION
<b>First Named Inventor/Applicant Name:</b>	Henrik ÖJELUND
<b>Customer Number:</b>	21839
<b>Filer:</b>	Stephany Gale Small/Ebony Jennings
<b>Filer Authorized By:</b>	Stephany Gale Small
<b>Attorney Docket Number:</b>	0079124-000266
<b>Receipt Date:</b>	28-OCT-2019
<b>Filing Date:</b>	30-JUL-2019
<b>Time Stamp:</b>	17:05:59
<b>Application Type:</b>	Utility under 35 USC 111(a)

### Payment information:

Submitted with Payment	no
------------------------	----

### File Listing:

Document Number	Document Description	File Name	File Size(Bytes)/ Message Digest	Multi Part /.zip	Pages (if appl.)
1	Non Patent Literature	63-1_Exhibit_1002_675_file_historystory.pdf	6730545  1f53ad5c2f3638eb556ca653002d6c96618dd3b1	no	156

### Warnings:

<b>Information:</b>					
2	Non Patent Literature	63-2_Exhibit_1002_675_file_hi story.pdf	8447465 2f6aa3ffd8038ebc67788972a82084187edd 8126	no	156
<b>Warnings:</b>					
<b>Information:</b>					
3	Non Patent Literature	63-3_Exhibit_1002_675_file_hi story.pdf	6740151 44d19405a5d1636d2a6e832ba4c1a3996cb f4721	no	156
<b>Warnings:</b>					
<b>Information:</b>					
4	Non Patent Literature	63-4_Exhibit_1002_675_file_hi story.pdf	6415171 4e67555e235fd52fc4f0bd9422def5df8ff0e 61	no	157
<b>Warnings:</b>					
<b>Information:</b>					
<b>Total Files Size (in bytes):</b>				28333332	
<p><b>This Acknowledgement Receipt evidences receipt on the noted date by the USPTO of the indicated documents, characterized by the applicant, and including page counts, where applicable. It serves as evidence of receipt similar to a Post Card, as described in MPEP 503.</b></p> <p><b><u>New Applications Under 35 U.S.C. 111</u></b>  <b>If a new application is being filed and the application includes the necessary components for a filing date (see 37 CFR 1.53(b)-(d) and MPEP 506), a Filing Receipt (37 CFR 1.54) will be issued in due course and the date shown on this Acknowledgement Receipt will establish the filing date of the application.</b></p> <p><b><u>National Stage of an International Application under 35 U.S.C. 371</u></b>  <b>If a timely submission to enter the national stage of an international application is compliant with the conditions of 35 U.S.C. 371 and other applicable requirements a Form PCT/DO/EO/903 indicating acceptance of the application as a national stage submission under 35 U.S.C. 371 will be issued in addition to the Filing Receipt, in due course.</b></p> <p><b><u>New International Application Filed with the USPTO as a Receiving Office</u></b>  <b>If a new international application is being filed and the international application includes the necessary components for an international filing date (see PCT Article 11 and MPEP 1810), a Notification of the International Application Number and of the International Filing Date (Form PCT/RO/105) will be issued in due course, subject to prescriptions concerning national security, and the date shown on this Acknowledgement Receipt will establish the international filing date of the application.</b></p>					

PATENT APPLICATION FEE DETERMINATION RECORD Substitute for Form PTO-875		Application or Docket Number 16/526,281		Filing Date 07/30/2019		<input type="checkbox"/> To be Mailed	
ENTITY: <input checked="" type="checkbox"/> LARGE <input type="checkbox"/> SMALL <input type="checkbox"/> MICRO							
<b>APPLICATION AS FILED - PART I</b>							
	(Column 1)	(Column 2)					
FOR	NUMBER FILED	NUMBER EXTRA		RATE (\$)		FEE (\$)	
<input type="checkbox"/> BASIC FEE (37 CFR 1.16(a), (b), or (c))	N/A	N/A		N/A			
<input type="checkbox"/> SEARCH FEE (37 CFR 1.16(k), (l), or (m))	N/A	N/A		N/A			
<input type="checkbox"/> EXAMINATION FEE (37 CFR 1.16(o), (p), or (q))	N/A	N/A		N/A			
TOTAL CLAIMS (37 CFR 1.16(j))	minus 20 = *			x \$100 =			
INDEPENDENT CLAIMS (37 CFR 1.16(h))	minus 3 = *			x \$460 =			
<input type="checkbox"/> APPLICATION SIZE FEE (37 CFR 1.16(s))	If the specification and drawings exceed 100 sheets of paper, the application size fee due is \$310 (\$155 for small entity) for each additional 50 sheets or fraction thereof. See 35 U.S.C. 41(a)(1)(G) and 37 CFR 1.16(s).						
<input type="checkbox"/> MULTIPLE DEPENDENT CLAIM PRESENT (37 CFR 1.16(j))							
* If the difference in column 1 is less than zero, enter "0" in column 2.					TOTAL		
<b>APPLICATION AS AMENDED - PART II</b>							
	(Column 1)	(Column 2)	(Column 3)				
AMENDMENT	10/28/2019	CLAIMS REMAINING AFTER AMENDMENT	HIGHEST NUMBER PREVIOUSLY PAID FOR	PRESENT EXTRA		RATE (\$)	ADDITIONAL FEE (\$)
Total (37 CFR 1.16(i))	* 43	Minus	** 38	= 5		x \$100 =	500
Independent (37 CFR 1.16(h))	* 3	Minus	*** 3	= 0		x \$460 =	0
<input type="checkbox"/> Application Size Fee (37 CFR 1.16(s))							
<input type="checkbox"/> FIRST PRESENTATION OF MULTIPLE DEPENDENT CLAIM (37 CFR 1.16(j))							
						TOTAL ADD'L FEE	500
	(Column 1)	(Column 2)	(Column 3)				
AMENDMENT		CLAIMS REMAINING AFTER AMENDMENT	HIGHEST NUMBER PREVIOUSLY PAID FOR	PRESENT EXTRA		RATE (\$)	ADDITIONAL FEE (\$)
Total (37 CFR 1.16(i))	*	Minus	**	=		x \$0 =	
Independent (37 CFR 1.16(h))	*	Minus	***	=		x \$0 =	
<input type="checkbox"/> Application Size Fee (37 CFR 1.16(s))							
<input type="checkbox"/> FIRST PRESENTATION OF MULTIPLE DEPENDENT CLAIM (37 CFR 1.16(j))							
						TOTAL ADD'L FEE	
* If the entry in column 1 is less than the entry in column 2, write "0" in column 3.						LIE	
** If the "Highest Number Previously Paid For" IN THIS SPACE is less than 20, enter "20".						/EFREM WARREN/	
*** If the "Highest Number Previously Paid For" IN THIS SPACE is less than 3, enter "3".							
The "Highest Number Previously Paid For" (Total or Independent) is the highest number found in the appropriate box in column 1.							

This collection of information is required by 37 CFR 1.16. The information is required to obtain or retain a benefit by the public which is to file (and by the USPTO to process) an application. Confidentiality is governed by 35 U.S.C. 122 and 37 CFR 1.14. This collection is estimated to take 12 minutes to complete, including gathering, preparing, and submitting the completed application form to the USPTO. Time will vary depending upon the individual case. Any comments on the amount of time you require to complete this form and/or suggestions for reducing this burden, should be sent to the Chief Information Officer, U.S. Patent and Trademark Office, U.S. Department of Commerce, P.O. Box 1450, Alexandria, VA 22313-1450. DO NOT SEND FEES OR COMPLETED FORMS TO THIS ADDRESS. **SEND TO: Commissioner for Patents, P.O. Box 1450, Alexandria, VA 22313-1450.**

If you need assistance in completing the form, call 1-800-PTO-9199 and select option 2.



UNITED STATES PATENT AND TRADEMARK OFFICE

UNITED STATES DEPARTMENT OF COMMERCE
United States Patent and Trademark Office
Address: COMMISSIONER FOR PATENTS
P.O. Box 1450
Alexandria, Virginia 22313-1450
www.uspto.gov

Table with 7 columns: APPLICATION NUMBER, FILING or 371(c) DATE, GRP ART UNIT, FIL FEE REC'D, ATTY DOCKET NO, TOT CLAIMS, IND CLAIMS. Row 1: 16/526,281, 07/30/2019, 3992, 4960, 0079124-000266, 38, 3

CONFIRMATION NO. 9657

CORRECTED FILING RECEIPT

21839
BUCHANAN, INGERSOLL & ROONEY PC
POST OFFICE BOX 1404
ALEXANDRIA, VA 22313-1404



Date Mailed: 08/20/2019

Receipt is acknowledged of this reissue patent application. The application will be taken up for examination in due course. Applicant will be notified as to the results of the examination. Any correspondence concerning the application must include the following identification information: the U.S. APPLICATION NUMBER, FILING DATE, NAME OF FIRST INVENTOR, and TITLE OF INVENTION. Fees transmitted by check or draft are subject to collection.

Please verify the accuracy of the data presented on this receipt. If an error is noted on this Filing Receipt, please submit a written request for a corrected Filing Receipt, including a properly marked-up ADS showing the changes with strike-through for deletions and underlining for additions. If you received a "Notice to File Missing Parts" or other Notice requiring a response for this application, please submit any request for correction to this Filing Receipt with your reply to the Notice. When the USPTO processes the reply to the Notice, the USPTO will generate another Filing Receipt incorporating the requested corrections provided that the request is grantable.

Inventor(s)

Henrik OJELUND, Lyngby, DENMARK;
David FISCHER, Stenløse, DENMARK;
Karl-Josef HOLLENBECK, København Ø, DENMARK;

Applicant(s)

3Shape A/S, Copenhagen K, DENMARK, Assignee (with 37 CFR 1.172 Interest);

Assignment For Published Patent Application

3Shape A/S, Copenhagen K, DK

Power of Attorney: The patent practitioners associated with Customer Number 21839

Domestic Priority data as claimed by applicant

This application is a REI of 13/991,513 06/04/2013 PAT 9329675
which is a 371 of PCT/DK2011/050461 12/05/2011
which claims benefit of 61/420,138 12/06/2010

Foreign Applications (You may be eligible to benefit from the Patent Prosecution Highway program at the USPTO. Please see http://www.uspto.gov for more information.)

DENMARK PA 2010 01104 12/06/2010 No Access Code Provided

Permission to Access Application via Priority Document Exchange: Yes

Permission to Access Search Results: Yes

Applicant may provide or rescind an authorization for access using Form PTO/SB/39 or Form PTO/SB/69 as appropriate.

**If Required, Foreign Filing License Granted:** 08/14/2019

The country code and number of your priority application, to be used for filing abroad under the Paris Convention, is **US 16/526,281**

**Projected Publication Date:** None, application is not eligible for pre-grant publication

**Non-Publication Request:** No

**Early Publication Request:** No  
**Title**

SYSTEM WITH 3D USER INTERFACE INTEGRATION

**Preliminary Class**

345

**Statement under 37 CFR 1.55 or 1.78 for AIA (First Inventor to File) Transition Applications:** No

## **PROTECTING YOUR INVENTION OUTSIDE THE UNITED STATES**

Since the rights granted by a U.S. patent extend only throughout the territory of the United States and have no effect in a foreign country, an inventor who wishes patent protection in another country must apply for a patent in a specific country or in regional patent offices. Applicants may wish to consider the filing of an international application under the Patent Cooperation Treaty (PCT). An international (PCT) application generally has the same effect as a regular national patent application in each PCT-member country. The PCT process **simplifies** the filing of patent applications on the same invention in member countries, but **does not result** in a grant of "an international patent" and does not eliminate the need of applicants to file additional documents and fees in countries where patent protection is desired.

Almost every country has its own patent law, and a person desiring a patent in a particular country must make an application for patent in that country in accordance with its particular laws. Since the laws of many countries differ in various respects from the patent law of the United States, applicants are advised to seek guidance from specific foreign countries to ensure that patent rights are not lost prematurely.

Applicants also are advised that in the case of inventions made in the United States, the Director of the USPTO must issue a license before applicants can apply for a patent in a foreign country. The filing of a U.S. patent application serves as a request for a foreign filing license. The application's filing receipt contains further information and guidance as to the status of applicant's license for foreign filing.

Applicants may wish to consult the USPTO booklet, "General Information Concerning Patents" (specifically, the section entitled "Treaties and Foreign Patents") for more information on timeframes and deadlines for filing foreign patent applications. The guide is available either by contacting the USPTO Contact Center at 800-786-9199, or it can be viewed on the USPTO website at <http://www.uspto.gov/web/offices/pac/doc/general/index.html>.

For information on preventing theft of your intellectual property (patents, trademarks and copyrights), you may wish to consult the U.S. Government website, <http://www.stopfakes.gov>. Part of a Department of Commerce initiative, this website includes self-help "toolkits" giving innovators guidance on how to protect intellectual property in specific

countries such as China, Korea and Mexico. For questions regarding patent enforcement issues, applicants may call the U.S. Government hotline at 1-866-999-HALT (1-866-999-4258).

**LICENSE FOR FOREIGN FILING UNDER  
Title 35, United States Code, Section 184  
Title 37, Code of Federal Regulations, 5.11 & 5.15**

**GRANTED**

The applicant has been granted a license under 35 U.S.C. 184, if the phrase "IF REQUIRED, FOREIGN FILING LICENSE GRANTED" followed by a date appears on this form. Such licenses are issued in all applications where the conditions for issuance of a license have been met, regardless of whether or not a license may be required as set forth in 37 CFR 5.15. The scope and limitations of this license are set forth in 37 CFR 5.15(a) unless an earlier license has been issued under 37 CFR 5.15(b). The license is subject to revocation upon written notification. The date indicated is the effective date of the license, unless an earlier license of similar scope has been granted under 37 CFR 5.13 or 5.14.

This license is to be retained by the licensee and may be used at any time on or after the effective date thereof unless it is revoked. This license is automatically transferred to any related applications(s) filed under 37 CFR 1.53(d). This license is not retroactive.

The grant of a license does not in any way lessen the responsibility of a licensee for the security of the subject matter as imposed by any Government contract or the provisions of existing laws relating to espionage and the national security or the export of technical data. Licensees should apprise themselves of current regulations especially with respect to certain countries, of other agencies, particularly the Office of Defense Trade Controls, Department of State (with respect to Arms, Munitions and Implements of War (22 CFR 121-128)); the Bureau of Industry and Security, Department of Commerce (15 CFR parts 730-774); the Office of Foreign Assets Control, Department of Treasury (31 CFR Parts 500+) and the Department of Energy.

**NOT GRANTED**

No license under 35 U.S.C. 184 has been granted at this time, if the phrase "IF REQUIRED, FOREIGN FILING LICENSE GRANTED" DOES NOT appear on this form. Applicant may still petition for a license under 37 CFR 5.12, if a license is desired before the expiration of 6 months from the filing date of the application. If 6 months has lapsed from the filing date of this application and the licensee has not received any indication of a secrecy order under 35 U.S.C. 181, the licensee may foreign file the application pursuant to 37 CFR 5.15(b).

---

**SelectUSA**

The United States represents the largest, most dynamic marketplace in the world and is an unparalleled location for business investment, innovation, and commercialization of new technologies. The U.S. offers tremendous resources and advantages for those who invest and manufacture goods here. Through SelectUSA, our nation works to promote and facilitate business investment. SelectUSA provides information assistance to the international investor community; serves as an ombudsman for existing and potential investors; advocates on behalf of U.S. cities, states, and regions competing for global investment; and counsels U.S. economic development organizations on investment attraction best practices. To learn more about why the United States is the best country in the world to develop

technology, manufacture products, deliver services, and grow your business, visit <http://www.SelectUSA.gov> or call +1-202-482-6800.

**PATENT APPLICATION FEE DETERMINATION RECORD**  
Substitute for Form PTO-875

Application or Docket Number  
16/526,281

**APPLICATION AS FILED - PART I**

(Column 1)		(Column 2)	SMALL ENTITY		OR	OTHER THAN SMALL ENTITY	
FOR	NUMBER FILED	NUMBER EXTRA	RATE(\$)	FEE(\$)		RATE(\$)	FEE(\$)
BASIC FEE (37 CFR 1.16(a), (b), or (c))	N/A	N/A	N/A			N/A	300
SEARCH FEE (37 CFR 1.16(k), (i), or (m))	N/A	N/A	N/A			N/A	660
EXAMINATION FEE (37 CFR 1.16(o), (p), or (q))	N/A	N/A	N/A			N/A	2200
TOTAL CLAIMS (37 CFR 1.16(i))	38	minus 20 = *			OR	x 100 =	1800
INDEPENDENT CLAIMS (37 CFR 1.16(h))	3	minus 3 = *			OR	x 460 =	0.00
APPLICATION SIZE FEE (37 CFR 1.16(s))	If the specification and drawings exceed 100 sheets of paper, the application size fee due is \$310 (\$155 for small entity) for each additional 50 sheets or fraction thereof. See 35 U.S.C. 41(a)(1)(G) and 37 CFR 1.16(s).						0.00
MULTIPLE DEPENDENT CLAIM PRESENT (37 CFR 1.16(j))							0.00
* If the difference in column 1 is less than zero, enter "0" in column 2.			TOTAL			TOTAL	4960

**APPLICATION AS AMENDED - PART II**

(Column 1)		(Column 2)	(Column 3)	SMALL ENTITY		OR	OTHER THAN SMALL ENTITY	
AMENDMENT A	CLAIMS REMAINING AFTER AMENDMENT	HIGHEST NUMBER PREVIOUSLY PAID FOR	PRESENT EXTRA	RATE(\$)	ADDITIONAL FEE(\$)		RATE(\$)	ADDITIONAL FEE(\$)
Total (37 CFR 1.16(i))	*	Minus **	**	x =		OR	x =	
Independent (37 CFR 1.16(h))	*	Minus ***	***	x =		OR	x =	
Application Size Fee (37 CFR 1.16(s))						OR		
FIRST PRESENTATION OF MULTIPLE DEPENDENT CLAIM (37 CFR 1.16(j))						OR		
				TOTAL ADD'L FEE		OR	TOTAL ADD'L FEE	
AMENDMENT B	CLAIMS REMAINING AFTER AMENDMENT	HIGHEST NUMBER PREVIOUSLY PAID FOR	PRESENT EXTRA	RATE(\$)	ADDITIONAL FEE(\$)		RATE(\$)	ADDITIONAL FEE(\$)
Total (37 CFR 1.16(i))	*	Minus **	**	x =		OR	x =	
Independent (37 CFR 1.16(h))	*	Minus ***	***	x =		OR	x =	
Application Size Fee (37 CFR 1.16(s))						OR		
FIRST PRESENTATION OF MULTIPLE DEPENDENT CLAIM (37 CFR 1.16(j))						OR		
				TOTAL ADD'L FEE		OR	TOTAL ADD'L FEE	

\* If the entry in column 1 is less than the entry in column 2, write "0" in column 3.  
 \*\* If the "Highest Number Previously Paid For" IN THIS SPACE is less than 20, enter "20".  
 \*\*\* If the "Highest Number Previously Paid For" IN THIS SPACE is less than 3, enter "3".  
 The "Highest Number Previously Paid For" (Total or Independent) is the highest found in the appropriate box in column 1.





UNITED STATES PATENT AND TRADEMARK OFFICE

UNITED STATES DEPARTMENT OF COMMERCE
United States Patent and Trademark Office
Address: COMMISSIONER FOR PATENTS
P.O. Box 1450
Alexandria, Virginia 22313-1450
www.uspto.gov

Table with 7 columns: APPLICATION NUMBER, FILING or 371(c) DATE, GRP ART UNIT, FIL FEE REC'D, ATTY DOCKET NO, TOT CLAIMS, IND CLAIMS. Row 1: 16/526,281, 07/30/2019, 2621, 4960, 0079124-000266, 38, 3

CONFIRMATION NO. 9657

FILING RECEIPT

21839
BUCHANAN, INGERSOLL & ROONEY PC
POST OFFICE BOX 1404
ALEXANDRIA, VA 22313-1404



Date Mailed: 08/15/2019

Receipt is acknowledged of this reissue patent application. The application will be taken up for examination in due course. Applicant will be notified as to the results of the examination. Any correspondence concerning the application must include the following identification information: the U.S. APPLICATION NUMBER, FILING DATE, NAME OF FIRST INVENTOR, and TITLE OF INVENTION. Fees transmitted by check or draft are subject to collection.

Please verify the accuracy of the data presented on this receipt. If an error is noted on this Filing Receipt, please submit a written request for a corrected Filing Receipt, including a properly marked-up ADS showing the changes with strike-through for deletions and underlining for additions. If you received a "Notice to File Missing Parts" or other Notice requiring a response for this application, please submit any request for correction to this Filing Receipt with your reply to the Notice. When the USPTO processes the reply to the Notice, the USPTO will generate another Filing Receipt incorporating the requested corrections provided that the request is grantable.

Inventor(s)

Henrik OJELUND, Lyngby, DENMARK;
David FISCHER, Stenløse, DENMARK;
Karl-Josef HOLLENBECK, København Ø, DENMARK;

Applicant(s)

3Shape A/S, Residence Not Provided, Assignee (with 37 CFR 1.172 Interest);

Assignment For Published Patent Application

3Shape A/S, Copenhagen K, DK

Power of Attorney: The patent practitioners associated with Customer Number 21839

Domestic Priority data as claimed by applicant

This application is a REI of 13/991,513 06/04/2013 PAT 9329675
which is a 371 of PCT/DK2011/050461 12/05/2011
which claims benefit of 61/420,138 12/06/2010

Foreign Applications (You may be eligible to benefit from the Patent Prosecution Highway program at the USPTO. Please see http://www.uspto.gov for more information.)

DENMARK PA 2010 01104 12/06/2010 No Access Code Provided

Permission to Access Application via Priority Document Exchange: Yes

Permission to Access Search Results: Yes

Applicant may provide or rescind an authorization for access using Form PTO/SB/39 or Form PTO/SB/69 as appropriate.

**If Required, Foreign Filing License Granted:** 08/14/2019

The country code and number of your priority application, to be used for filing abroad under the Paris Convention, is **US 16/526,281**

**Projected Publication Date:** None, application is not eligible for pre-grant publication

**Non-Publication Request:** No

**Early Publication Request:** No  
**Title**

SYSTEM WITH 3D USER INTERFACE INTEGRATION

**Preliminary Class**

345

**Statement under 37 CFR 1.55 or 1.78 for AIA (First Inventor to File) Transition Applications:** No

### **PROTECTING YOUR INVENTION OUTSIDE THE UNITED STATES**

Since the rights granted by a U.S. patent extend only throughout the territory of the United States and have no effect in a foreign country, an inventor who wishes patent protection in another country must apply for a patent in a specific country or in regional patent offices. Applicants may wish to consider the filing of an international application under the Patent Cooperation Treaty (PCT). An international (PCT) application generally has the same effect as a regular national patent application in each PCT-member country. The PCT process **simplifies** the filing of patent applications on the same invention in member countries, but **does not result** in a grant of "an international patent" and does not eliminate the need of applicants to file additional documents and fees in countries where patent protection is desired.

Almost every country has its own patent law, and a person desiring a patent in a particular country must make an application for patent in that country in accordance with its particular laws. Since the laws of many countries differ in various respects from the patent law of the United States, applicants are advised to seek guidance from specific foreign countries to ensure that patent rights are not lost prematurely.

Applicants also are advised that in the case of inventions made in the United States, the Director of the USPTO must issue a license before applicants can apply for a patent in a foreign country. The filing of a U.S. patent application serves as a request for a foreign filing license. The application's filing receipt contains further information and guidance as to the status of applicant's license for foreign filing.

Applicants may wish to consult the USPTO booklet, "General Information Concerning Patents" (specifically, the section entitled "Treaties and Foreign Patents") for more information on timeframes and deadlines for filing foreign patent applications. The guide is available either by contacting the USPTO Contact Center at 800-786-9199, or it can be viewed on the USPTO website at <http://www.uspto.gov/web/offices/pac/doc/general/index.html>.

For information on preventing theft of your intellectual property (patents, trademarks and copyrights), you may wish to consult the U.S. Government website, <http://www.stopfakes.gov>. Part of a Department of Commerce initiative, this website includes self-help "toolkits" giving innovators guidance on how to protect intellectual property in specific

countries such as China, Korea and Mexico. For questions regarding patent enforcement issues, applicants may call the U.S. Government hotline at 1-866-999-HALT (1-866-999-4258).

**LICENSE FOR FOREIGN FILING UNDER  
Title 35, United States Code, Section 184  
Title 37, Code of Federal Regulations, 5.11 & 5.15**

**GRANTED**

The applicant has been granted a license under 35 U.S.C. 184, if the phrase "IF REQUIRED, FOREIGN FILING LICENSE GRANTED" followed by a date appears on this form. Such licenses are issued in all applications where the conditions for issuance of a license have been met, regardless of whether or not a license may be required as set forth in 37 CFR 5.15. The scope and limitations of this license are set forth in 37 CFR 5.15(a) unless an earlier license has been issued under 37 CFR 5.15(b). The license is subject to revocation upon written notification. The date indicated is the effective date of the license, unless an earlier license of similar scope has been granted under 37 CFR 5.13 or 5.14.

This license is to be retained by the licensee and may be used at any time on or after the effective date thereof unless it is revoked. This license is automatically transferred to any related applications(s) filed under 37 CFR 1.53(d). This license is not retroactive.

The grant of a license does not in any way lessen the responsibility of a licensee for the security of the subject matter as imposed by any Government contract or the provisions of existing laws relating to espionage and the national security or the export of technical data. Licensees should apprise themselves of current regulations especially with respect to certain countries, of other agencies, particularly the Office of Defense Trade Controls, Department of State (with respect to Arms, Munitions and Implements of War (22 CFR 121-128)); the Bureau of Industry and Security, Department of Commerce (15 CFR parts 730-774); the Office of Foreign Assets Control, Department of Treasury (31 CFR Parts 500+) and the Department of Energy.

**NOT GRANTED**

No license under 35 U.S.C. 184 has been granted at this time, if the phrase "IF REQUIRED, FOREIGN FILING LICENSE GRANTED" DOES NOT appear on this form. Applicant may still petition for a license under 37 CFR 5.12, if a license is desired before the expiration of 6 months from the filing date of the application. If 6 months has lapsed from the filing date of this application and the licensee has not received any indication of a secrecy order under 35 U.S.C. 181, the licensee may foreign file the application pursuant to 37 CFR 5.15(b).

---

**SelectUSA**

The United States represents the largest, most dynamic marketplace in the world and is an unparalleled location for business investment, innovation, and commercialization of new technologies. The U.S. offers tremendous resources and advantages for those who invest and manufacture goods here. Through SelectUSA, our nation works to promote and facilitate business investment. SelectUSA provides information assistance to the international investor community; serves as an ombudsman for existing and potential investors; advocates on behalf of U.S. cities, states, and regions competing for global investment; and counsels U.S. economic development organizations on investment attraction best practices. To learn more about why the United States is the best country in the world to develop

technology, manufacture products, deliver services, and grow your business, visit <http://www.SelectUSA.gov> or call +1-202-482-6800.

REISSUE PATENT APPLICATION TRANSMITTAL			
<b>Address to:</b>  <b>Mail Stop Reissue</b> <b>Commissioner for Patents</b> <b>P.O. Box 1450</b> <b>Alexandria, VA 22313-1450</b>		Attorney Docket No.	0079124-000266
		First Named Inventor	Henrik Ojelund
		Original Patent Number	9,329,675
		Original Patent Issue Date (Month/Day/Year)	05/03/2016
		Express Mail Label No.	
<b>APPLICATION FOR REISSUE OF:</b> (Check applicable box) <input checked="" type="checkbox"/> Utility Patent <input type="checkbox"/> Design Patent <input type="checkbox"/> Plant Patent			
<b>APPLICATION ELEMENTS (37 CFR 1.173)</b>		<b>ACCOMPANYING APPLICATION PARTS</b>	
1. <input checked="" type="checkbox"/> <b>Fee Transmittal Form</b> (PTO/SB/56) 2. <input type="checkbox"/> <b>Applicant asserts small entity status.</b> See 37 CFR 1.27 3. <input type="checkbox"/> <b>Applicant certifies micro entity status.</b> See 37 CFR 1.29. Applicant must attach form PTO/SB/15A or B or equivalent. 4. <input checked="" type="checkbox"/> <b>Specification and Claims</b> in double column copy of patent format (amended, if appropriate) 5. <input checked="" type="checkbox"/> <b>Drawing(s)</b> (proposed amendments, if appropriate) 6. <input checked="" type="checkbox"/> <b>Reissue Oath/Declaration or Substitute Statement</b> (37 CFR 1.175) (PTO/AIA/05, 06, or 07) 7. <input checked="" type="checkbox"/> <b>Application Data Sheet</b> NOTE: Benefit claims under 37 CFR 1.78 and foreign priority claims under 37 CFR 1.55 MUST be set forth in an Application Data Sheet (ADS). 8. <input checked="" type="checkbox"/> <b>Original U.S. Patent currently assigned?</b> <input checked="" type="checkbox"/> Yes <input type="checkbox"/> No (If Yes, check applicable box(es)) <input checked="" type="checkbox"/> Written Consent of all Assignees (PTO/AIA/53) <input checked="" type="checkbox"/> 37 CFR 3.73(c) Statement (PTO/AIA/96) 9. <input type="checkbox"/> <b>CD-ROM or CD-R</b> in duplicate, Computer Program (Appendix) or large table <input type="checkbox"/> Landscape Table on CD 10. <b>Nucleotide and/or Amino Acid Sequence Submission</b> (if applicable, items a. - c. are required) a. <input type="checkbox"/> Computer Readable Form (CRF) b. <input type="checkbox"/> Specification Sequence Listing on: i. <input type="checkbox"/> CD-ROM (2 copies) or CD-R (2 copies); or ii. <input type="checkbox"/> Paper c. <input type="checkbox"/> Statements verifying identity of above copies		11. <input checked="" type="checkbox"/> <b>Statement of status and support for all changes to the claims.</b> See 37 CFR 1.173(c). 12. <input checked="" type="checkbox"/> <b>Power of Attorney</b> 13. <input type="checkbox"/> <b>Information Disclosure Statement (IDS)</b> PTO/SB/08 or PTO-1449 <input type="checkbox"/> Copies of citations attached 14. <input type="checkbox"/> <b>English translation of Reissue Oath/Declaration</b> (if applicable) 15. <input type="checkbox"/> <b>Return Receipt Postcard (MPEP § 503)</b> (should be specifically itemized) 16. <input checked="" type="checkbox"/> <b>Preliminary Amendment</b> (37 CFR 1.173; MPEP § 1453) 17. <input checked="" type="checkbox"/> <b>Other:</b> <u>General Authorization For Postoffice For Extension Of Time And Payment Of Fees</u> _____ _____ _____ _____ <input type="checkbox"/> This is a continuation reissue or divisional reissue application (i.e., a second or subsequent reissue application for the same issued patent). (Check box if applicable.)	
<b>18. CORRESPONDENCE ADDRESS</b> <input checked="" type="checkbox"/> The address associated with Customer Number: <u>21839</u> OR <input type="checkbox"/> Correspondence address below			
Name			
Address			
City		State	Zip Code
Country		Telephone	
Email			
Signature		Date	
/Stephany G. Small/		July 30, 2019	
Name (Print/Type)		Registration No.	
Stephany G. Small		69,532	

This collection of information is required by 37 CFR 1.173. The information is required to obtain or retain a benefit by the public which is to file (and by the USPTO to process) an application. Confidentiality is governed by 35 U.S.C. 122 and 37 CFR 1.11 and 1.14. This collection is estimated to take 12 minutes to complete, including gathering, preparing, and submitting the completed application form to the USPTO. Time will vary depending upon the individual case. Any comments on the amount of time you require to complete this form and/or suggestions for reducing this burden, should be sent to the Chief Information Officer, U.S. Patent and Trademark Office, U.S. Department of Commerce, P.O. Box 1450, Alexandria, VA 22313-1450. DO NOT SEND FEES OR COMPLETED FORMS TO THIS ADDRESS. SEND TO: Mail Stop Reissue, Commissioner for Patents, P.O. Box 1450, Alexandria, VA 22313-1450.

If you need assistance in completing the form, call 1-800-PTO-9199 and select option 2.

Under the Paperwork Reduction Act of 1995, no persons are required to respond to a collection of information unless it contains a valid OMB control number.

<b>Application Data Sheet 37 CFR 1.76</b>		Attorney Docket Number	0079124-000266
		Application Number	
Title of Invention	SYSTEM WITH 3D USER INTERFACE INTEGRATION		
The application data sheet is part of the provisional or nonprovisional application for which it is being submitted. The following form contains the bibliographic data arranged in a format specified by the United States Patent and Trademark Office as outlined in 37 CFR 1.76. This document may be completed electronically and submitted to the Office in electronic format using the Electronic Filing System (EFS) or the document may be printed and included in a paper filed application.			

### Secrecy Order 37 CFR 5.2:

Portions or all of the application associated with this Application Data Sheet may fall under a Secrecy Order pursuant to 37 CFR 5.2 (Paper filers only. Applications that fall under Secrecy Order may not be filed electronically.)

### Inventor Information:

<b>Inventor</b> 1					<input type="button" value="Remove"/>
<b>Legal Name</b>					
<b>Prefix</b>	<b>Given Name</b>	<b>Middle Name</b>	<b>Family Name</b>	<b>Suffix</b>	
	Henrik		OJELUND		
<b>Residence Information (Select One)</b> US Residency <input type="radio"/> Non US Residency <input type="radio"/> Active US Military Service					
<b>City</b>	Lyngby	<b>Country of Residence <sup>i</sup></b>	DK		
<b>Mailing Address of Inventor:</b>					
<b>Address 1</b>	Kulsvierparken 55				
<b>Address 2</b>					
<b>City</b>	Lyngby	<b>State/Province</b>			
<b>Postal Code</b>	DK-2800	<b>Country <sup>i</sup></b>	DK		
<b>Inventor</b> 2					<input type="button" value="Remove"/>
<b>Legal Name</b>					
<b>Prefix</b>	<b>Given Name</b>	<b>Middle Name</b>	<b>Family Name</b>	<b>Suffix</b>	
	David		FISCHER		
<b>Residence Information (Select One)</b> US Residency <input type="radio"/> Non US Residency <input checked="" type="radio"/> Active US Military Service					
<b>City</b>	Stenløse	<b>Country of Residence <sup>i</sup></b>	DK		
<b>Mailing Address of Inventor:</b>					
<b>Address 1</b>	Rådyleddet 16				
<b>Address 2</b>					
<b>City</b>	Stenløse	<b>State/Province</b>			
<b>Postal Code</b>	DK-3660	<b>Country <sup>i</sup></b>	DK		
<b>Inventor</b> 3					<input type="button" value="Remove"/>
<b>Legal Name</b>					

Under the Paperwork Reduction Act of 1995, no persons are required to respond to a collection of information unless it contains a valid OMB control number.

<b>Application Data Sheet 37 CFR 1.76</b>		Attorney Docket Number	0079124-000266
		Application Number	
Title of Invention	SYSTEM WITH 3D USER INTERFACE INTEGRATION		

Prefix	Given Name	Middle Name	Family Name	Suffix
	Karl-Josef		HOLLENBECK	
<b>Residence Information (Select One)</b> US Residency <input checked="" type="radio"/> Non US Residency    Active US Military Service				
City	København Ø	Country of Residence <sup>i</sup>		
<b>Mailing Address of Inventor:</b>				
Address 1	Ribegade 12 3.th			
Address 2				
City	København Ø	State/Province		
Postal Code	DK-2100	Country <sup>i</sup>	DK	
All Inventors Must Be Listed - Additional Inventor Information blocks may be generated within this form by selecting the <b>Add</b> button.				<input type="button" value="Add"/>

**Correspondence Information:**

Enter either Customer Number or complete the Correspondence Information section below. For further information see 37 CFR 1.33(a).	
<input type="checkbox"/> An Address is being provided for the correspondence information of this application.	
Customer Number	21839
Email Address	<input type="button" value="Add Email"/> <input type="button" value="Remove Email"/>

**Application Information:**

Title of the Invention	SYSTEM WITH 3D USER INTERFACE INTEGRATION		
Attorney Docket Number	0079124-000266	Small Entity Status Claimed	<input type="checkbox"/>
Application Type	Nonprovisional		
Subject Matter	Utility		
Total Number of Drawing Sheets (if any)	5	Suggested Figure for Publication (if any)	2a

**Filing By Reference:**

Only complete this section when filing an application by reference under 35 U.S.C. 111(c) and 37 CFR 1.57(a). Do not complete this section if application papers including a specification and any drawings are being filed. Any domestic benefit or foreign priority information must be provided in the appropriate section(s) below (i.e., "Domestic Benefit/National Stage Information" and "Foreign Priority Information").

For the purposes of a filing date under 37 CFR 1.53(b), the description and any drawings of the present application are replaced by this reference to the previously filed application, subject to conditions and requirements of 37 CFR 1.57(a).

Application number of the previously filed application	Filing date (YYYY-MM-DD)	Intellectual Property Authority or Country <sup>i</sup>

Under the Paperwork Reduction Act of 1995, no persons are required to respond to a collection of information unless it contains a valid OMB control number.

<b>Application Data Sheet 37 CFR 1.76</b>		Attorney Docket Number	0079124-000266
		Application Number	
Title of Invention	SYSTEM WITH 3D USER INTERFACE INTEGRATION		

**Publication Information:**

<input type="checkbox"/>	Request Early Publication (Fee required at time of Request 37 CFR 1.219)
<input type="checkbox"/>	<b>Request Not to Publish.</b> I hereby request that the attached application not be published under 35 U.S.C. 122(b) and certify that the invention disclosed in the attached application <b>has not and will not</b> be the subject of an application filed in another country, or under a multilateral international agreement, that requires publication at eighteen months after filing.

**Representative Information:**

Representative information should be provided for all practitioners having a power of attorney in the application. Providing this information in the Application Data Sheet does not constitute a power of attorney in the application (see 37 CFR 1.32). Either enter Customer Number or complete the Representative Name section below. If both sections are completed the customer Number will be used for the Representative Information during processing.			
Please Select One:	<input checked="" type="radio"/> Customer Number	<input type="radio"/> US Patent Practitioner	<input type="radio"/> Limited Recognition (37 CFR 11.9)
Customer Number	21839		

**Domestic Benefit/National Stage Information:**

This section allows for the applicant to either claim benefit under 35 U.S.C. 119(e), 120, 121, 365(c), or 386(c) or indicate National Stage entry from a PCT application. Providing benefit claim information in the Application Data Sheet constitutes the specific reference required by 35 U.S.C. 119(e) or 120, and 37 CFR 1.78.

When referring to the current application, please leave the "Application Number" field blank.

Prior Application Status	Patented					Remove
Application Number	Continuity Type	Prior Application Number	Filing Date (YYYY-MM-DD)	Patent Number	Issue Date (YYYY-MM-DD)	
	reissued of	13991513	2013-06-04	9329675	2016-05-03	
Prior Application Status	Pending					Remove
Application Number	Continuity Type	Prior Application Number	Filing or 371(c) Date (YYYY-MM-DD)			
13991513	a 371 of international	PCT/DK2011/050461	2011-12-05			
Prior Application Status	Expired					Remove
Application Number	Continuity Type	Prior Application Number	Filing or 371(c) Date (YYYY-MM-DD)			
PCT/DK2011/050461	Claims benefit of provisional	61420138	2010-12-06			
Additional Domestic Benefit/National Stage Data may be generated within this form by selecting the <b>Add</b> button.						Add



Under the Paperwork Reduction Act of 1995, no persons are required to respond to a collection of information unless it contains a valid OMB control number.

<b>Application Data Sheet 37 CFR 1.76</b>		Attorney Docket Number	0079124-000266
		Application Number	
Title of Invention	SYSTEM WITH 3D USER INTERFACE INTEGRATION		

**Foreign Priority Information:**

This section allows for the applicant to claim priority to a foreign application. Providing this information in the application data sheet constitutes the claim for priority as required by 35 U.S.C. 119(b) and 37 CFR 1.55. When priority is claimed to a foreign application that is eligible for retrieval under the priority document exchange program (PDX)<sup>1</sup> the information will be used by the Office to automatically attempt retrieval pursuant to 37 CFR 1.55(i)(1) and (2). Under the PDX program, applicant bears the ultimate responsibility for ensuring that a copy of the foreign application is received by the Office from the participating foreign intellectual property office, or a certified copy of the foreign priority application is filed, within the time period specified in 37 CFR 1.55(g)(1).

Application Number	Country <sup>i</sup>	Filing Date (YYYY-MM-DD)	Access Code <sup>i</sup> (if applicable)
PA 2010 01104	DK	2010-12-06	

Additional Foreign Priority Data may be generated within this form by selecting the **Add** button.

**Statement under 37 CFR 1.55 or 1.78 for AIA (First Inventor to File) Transition Applications**

This application (1) claims priority to or the benefit of an application filed before March 16, 2013 and (2) also contains, or contained at any time, a claim to a claimed invention that has an effective filing date on or after March 16, 2013.

NOTE: By providing this statement under 37 CFR 1.55 or 1.78, this application, with a filing date on or after March 16, 2013, will be examined under the first inventor to file provisions of the AIA.

Under the Paperwork Reduction Act of 1995, no persons are required to respond to a collection of information unless it contains a valid OMB control number.

<b>Application Data Sheet 37 CFR 1.76</b>		Attorney Docket Number	0079124-000266
		Application Number	
Title of Invention	SYSTEM WITH 3D USER INTERFACE INTEGRATION		

## Authorization or Opt-Out of Authorization to Permit Access:

When this Application Data Sheet is properly signed and filed with the application, applicant has provided written authority to permit a participating foreign intellectual property (IP) office access to the instant application-as-filed (see paragraph A in subsection 1 below) and the European Patent Office (EPO) access to any search results from the instant application (see paragraph B in subsection 1 below).

Should applicant choose not to provide an authorization identified in subsection 1 below, applicant **must opt-out** of the authorization by checking the corresponding box A or B or both in subsection 2 below.

**NOTE:** This section of the Application Data Sheet is **ONLY** reviewed and processed with the **INITIAL** filing of an application. After the initial filing of an application, an Application Data Sheet cannot be used to provide or rescind authorization for access by a foreign IP office(s). Instead, Form PTO/SB/39 or PTO/SB/69 must be used as appropriate.

### 1. Authorization to Permit Access by a Foreign Intellectual Property Office(s)

**A. Priority Document Exchange (PDX)** - Unless box A in subsection 2 (opt-out of authorization) is checked, the undersigned hereby **grants the USPTO authority** to provide the European Patent Office (EPO), the Japan Patent Office (JPO), the Korean Intellectual Property Office (KIPO), the State Intellectual Property Office of the People's Republic of China (SIPO), the World Intellectual Property Organization (WIPO), and any other foreign intellectual property office participating with the USPTO in a bilateral or multilateral priority document exchange agreement in which a foreign application claiming priority to the instant patent application is filed, access to: (1) the instant patent application-as-filed and its related bibliographic data, (2) any foreign or domestic application to which priority or benefit is claimed by the instant application and its related bibliographic data, and (3) the date of filing of this Authorization. See 37 CFR 1.14(h)(1).

**B. Search Results from U.S. Application to EPO** - Unless box B in subsection 2 (opt-out of authorization) is checked, the undersigned hereby **grants the USPTO authority** to provide the EPO access to the bibliographic data and search results from the instant patent application when a European patent application claiming priority to the instant patent application is filed. See 37 CFR 1.14(h)(2).

The applicant is reminded that the EPO's Rule 141(1) EPC (European Patent Convention) requires applicants to submit a copy of search results from the instant application without delay in a European patent application that claims priority to the instant application.

### 2. Opt-Out of Authorizations to Permit Access by a Foreign Intellectual Property Office(s)

A. Applicant **DOES NOT** authorize the USPTO to permit a participating foreign IP office access to the instant application-as-filed. If this box is checked, the USPTO will not be providing a participating foreign IP office with any documents and information identified in subsection 1A above.

B. Applicant **DOES NOT** authorize the USPTO to transmit to the EPO any search results from the instant patent application. If this box is checked, the USPTO will not be providing the EPO with search results from the instant application.

**NOTE:** Once the application has published or is otherwise publicly available, the USPTO may provide access to the application in accordance with 37 CFR 1.14.

Under the Paperwork Reduction Act of 1995, no persons are required to respond to a collection of information unless it contains a valid OMB control number.

<b>Application Data Sheet 37 CFR 1.76</b>		Attorney Docket Number	0079124-000266
		Application Number	
Title of Invention	SYSTEM WITH 3D USER INTERFACE INTEGRATION		

### Applicant Information:

Providing assignment information in this section does not substitute for compliance with any requirement of part 3 of Title 37 of CFR to have an assignment recorded by the Office.			
<b>Applicant</b>	<b>1</b>	<input type="button" value="Remove"/>	
<p>If the applicant is the inventor (or the remaining joint inventor or inventors under 37 CFR 1.45), this section should not be completed. The information to be provided in this section is the name and address of the legal representative who is the applicant under 37 CFR 1.43; or the name and address of the assignee, person to whom the inventor is under an obligation to assign the invention, or person who otherwise shows sufficient proprietary interest in the matter who is the applicant under 37 CFR 1.46. If the applicant is an applicant under 37 CFR 1.46 (assignee, person to whom the inventor is obligated to assign, or person who otherwise shows sufficient proprietary interest) together with one or more joint inventors, then the joint inventor or inventors who are also the applicant should be identified in this section.</p>			
<input type="button" value="Clear"/>			
<input checked="" type="radio"/> Assignee	<input type="radio"/> Legal Representative under 35 U.S.C. 117	<input type="radio"/> Joint Inventor	
Person to whom the inventor is obligated to assign.		Person who shows sufficient proprietary interest	
If applicant is the legal representative, indicate the authority to file the patent application, the inventor is:			
<div style="border: 1px solid black; height: 20px; width: 100%;"></div>			
Name of the Deceased or Legally Incapacitated Inventor: <input type="text"/>			
If the Applicant is an Organization check here. <input checked="" type="checkbox"/>			
Organization Name	3Shape A/S		
<b>Mailing Address Information For Applicant:</b>			
Address 1	Holmens Kanal 7, 4. sal		
Address 2			
City	Copenhagen K	State/Province	
Country	DK	Postal Code	DK-1060
Phone Number		Fax Number	
Email Address			
Additional Applicant Data may be generated within this form by selecting the Add button. <input type="button" value="Add"/>			

### Assignee Information including Non-Applicant Assignee Information:

Providing assignment information in this section does not substitute for compliance with any requirement of part 3 of Title 37 of CFR to have an assignment recorded by the Office.

Under the Paperwork Reduction Act of 1995, no persons are required to respond to a collection of information unless it contains a valid OMB control number.

<b>Application Data Sheet 37 CFR 1.76</b>		Attorney Docket Number	0079124-000266
		Application Number	
Title of Invention	SYSTEM WITH 3D USER INTERFACE INTEGRATION		

<b>Assignee</b>	1		
Complete this section if assignee information, including non-applicant assignee information, is desired to be included on the patent application publication. An assignee-applicant identified in the "Applicant Information" section will appear on the patent application publication as an applicant. For an assignee-applicant, complete this section only if identification as an assignee is also desired on the patent application publication.			
			<input type="button" value="Remove"/>
If the Assignee or Non-Applicant Assignee is an Organization check here.			<input checked="" type="checkbox"/>
Organization Name	3Shape A/S		
<b>Mailing Address Information For Assignee including Non-Applicant Assignee:</b>			
Address 1	Holmens Kanal 7, 4. sal		
Address 2			
City	Copenhagen K	State/Province	
Country i	DK	Postal Code	DK-1060
Phone Number		Fax Number	
Email Address			
Additional Assignee or Non-Applicant Assignee Data may be generated within this form by selecting the Add button.			<input type="button" value="Add"/>

<b>Signature:</b>	<input type="button" value="Remove"/>		
<b>NOTE:</b> This Application Data Sheet must be signed in accordance with 37 CFR 1.33(b). However, if this Application Data Sheet is submitted with the <b>INITIAL</b> filing of the application and either box A or B is not checked in subsection 2 of the "Authorization or Opt-Out of Authorization to Permit Access" section, then this form must also be signed in accordance with 37 CFR 1.14(c).			
This Application Data Sheet <b>must</b> be signed by a patent practitioner if one or more of the applicants is a <b>juristic entity</b> (e.g., corporation or association). If the applicant is two or more joint inventors, this form must be signed by a patent practitioner, <b>all</b> joint inventors who are the applicant, or one or more joint inventor-applicants who have been given power of attorney (e.g., see USPTO Form PTO/AIA/81) on behalf of <b>all</b> joint inventor-applicants.			
See 37 CFR 1.4(d) for the manner of making signatures and certifications.			
Signature	/Stephany G. Small/	Date (YYYY-MM-DD)	2019-07-30
First Name	Stephany G.	Last Name	Small
		Registration Number	69,532
Additional Signature may be generated within this form by selecting the Add button.			<input type="button" value="Add"/>

Under the Paperwork Reduction Act of 1995, no persons are required to respond to a collection of information unless it contains a valid OMB control number.

<b>Application Data Sheet 37 CFR 1.76</b>		Attorney Docket Number	0079124-000266
		Application Number	
Title of Invention	SYSTEM WITH 3D USER INTERFACE INTEGRATION		

This collection of information is required by 37 CFR 1.76. The information is required to obtain or retain a benefit by the public which is to file (and by the USPTO to process) an application. Confidentiality is governed by 35 U.S.C. 122 and 37 CFR 1.14. This collection is estimated to take 23 minutes to complete, including gathering, preparing, and submitting the completed application data sheet form to the USPTO. Time will vary depending upon the individual case. Any comments on the amount of time you require to complete this form and/or suggestions for reducing this burden, should be sent to the Chief Information Officer, U.S. Patent and Trademark Office, U.S. Department of Commerce, P.O. Box 1450, Alexandria, VA 22313-1450. DO NOT SEND FEES OR COMPLETED FORMS TO THIS ADDRESS. **SEND TO: Commissioner for Patents, P.O. Box 1450, Alexandria, VA 22313-1450.**

## Privacy Act Statement

The Privacy Act of 1974 (P.L. 93-579) requires that you be given certain information in connection with your submission of the attached form related to a patent application or patent. Accordingly, pursuant to the requirements of the Act, please be advised that: (1) the general authority for the collection of this information is 35 U.S.C. 2(b)(2); (2) furnishing of the information solicited is voluntary; and (3) the principal purpose for which the information is used by the U.S. Patent and Trademark Office is to process and/or examine your submission related to a patent application or patent. If you do not furnish the requested information, the U.S. Patent and Trademark Office may not be able to process and/or examine your submission, which may result in termination of proceedings or abandonment of the application or expiration of the patent.

The information provided by you in this form will be subject to the following routine uses:

- 1 The information on this form will be treated confidentially to the extent allowed under the Freedom of Information Act (5 U.S.C. 552) and the Privacy Act (5 U.S.C. 552a). Records from this system of records may be disclosed to the Department of Justice to determine whether the Freedom of Information Act requires disclosure of these records.
- 2 A record from this system of records may be disclosed, as a routine use, in the course of presenting evidence to a court, magistrate, or administrative tribunal, including disclosures to opposing counsel in the course of settlement negotiations.
- 3 A record in this system of records may be disclosed, as a routine use, to a Member of Congress submitting a request involving an individual, to whom the record pertains, when the individual has requested assistance from the Member with respect to the subject matter of the record.
- 4 A record in this system of records may be disclosed, as a routine use, to a contractor of the Agency having need for the information in order to perform a contract. Recipients of information shall be required to comply with the requirements of the Privacy Act of 1974, as amended, pursuant to 5 U.S.C. 552a(m).
- 5 A record related to an International Application filed under the Patent Cooperation Treaty in this system of records may be disclosed, as a routine use, to the International Bureau of the World Intellectual Property Organization, pursuant to the Patent Cooperation Treaty.
- 6 A record in this system of records may be disclosed, as a routine use, to another federal agency for purposes of National Security review (35 U.S.C. 181) and for review pursuant to the Atomic Energy Act (42 U.S.C. 218(c)).
- 7 A record from this system of records may be disclosed, as a routine use, to the Administrator, General Services, or his/her designee, during an inspection of records conducted by GSA as part of that agency's responsibility to recommend improvements in records management practices and programs, under authority of 44 U.S.C. 2904 and 2906. Such disclosure shall be made in accordance with the GSA regulations governing inspection of records for this purpose, and any other relevant (i.e., GSA or Commerce) directive. Such disclosure shall not be used to make determinations about individuals.
- 8 A record from this system of records may be disclosed, as a routine use, to the public after either publication of the application pursuant to 35 U.S.C. 122(b) or issuance of a patent pursuant to 35 U.S.C. 151. Further, a record may be disclosed, subject to the limitations of 37 CFR 1.14, as a routine use, to the public if the record was filed in an application which became abandoned or in which the proceedings were terminated and which application is referenced by either a published application, an application open to public inspections or an issued patent.
- 9 A record from this system of records may be disclosed, as a routine use, to a Federal, State, or local law enforcement agency, if the USPTO becomes aware of a violation or potential violation of law or regulation.

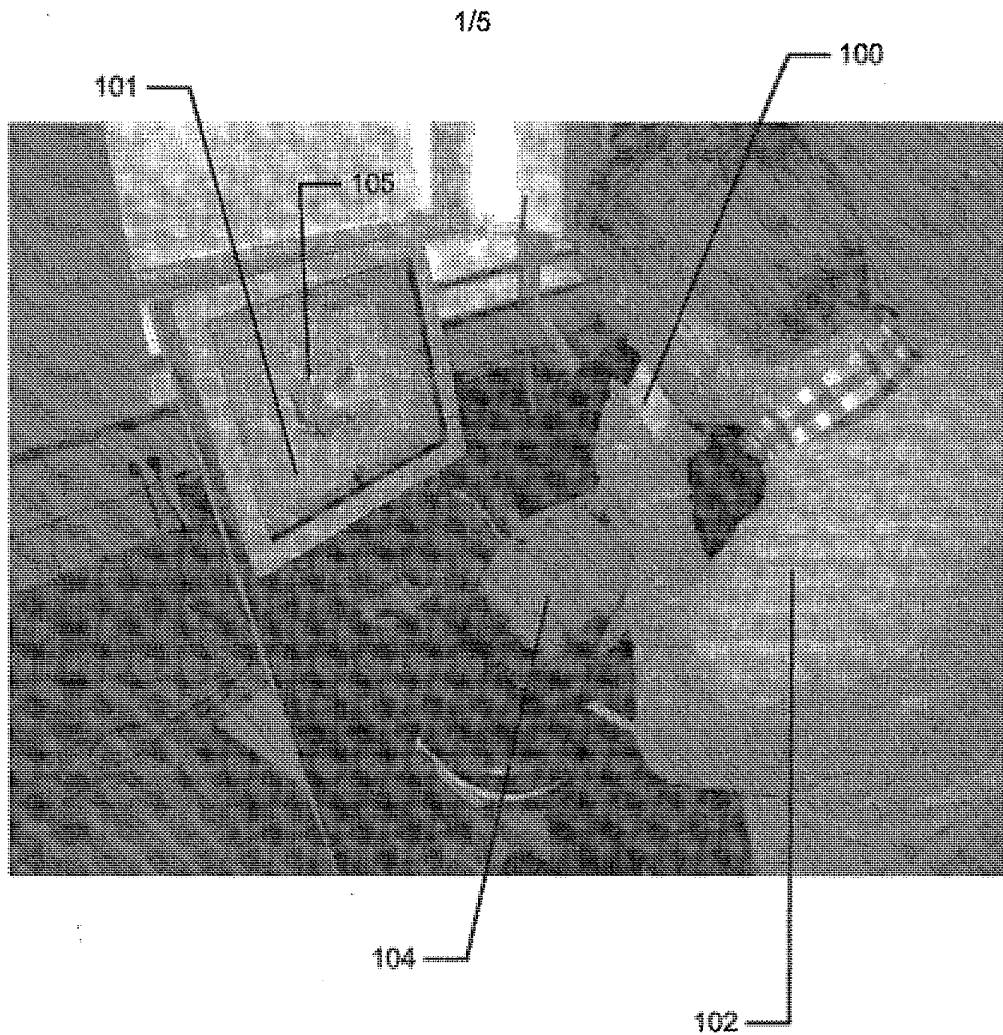

Fig. 1

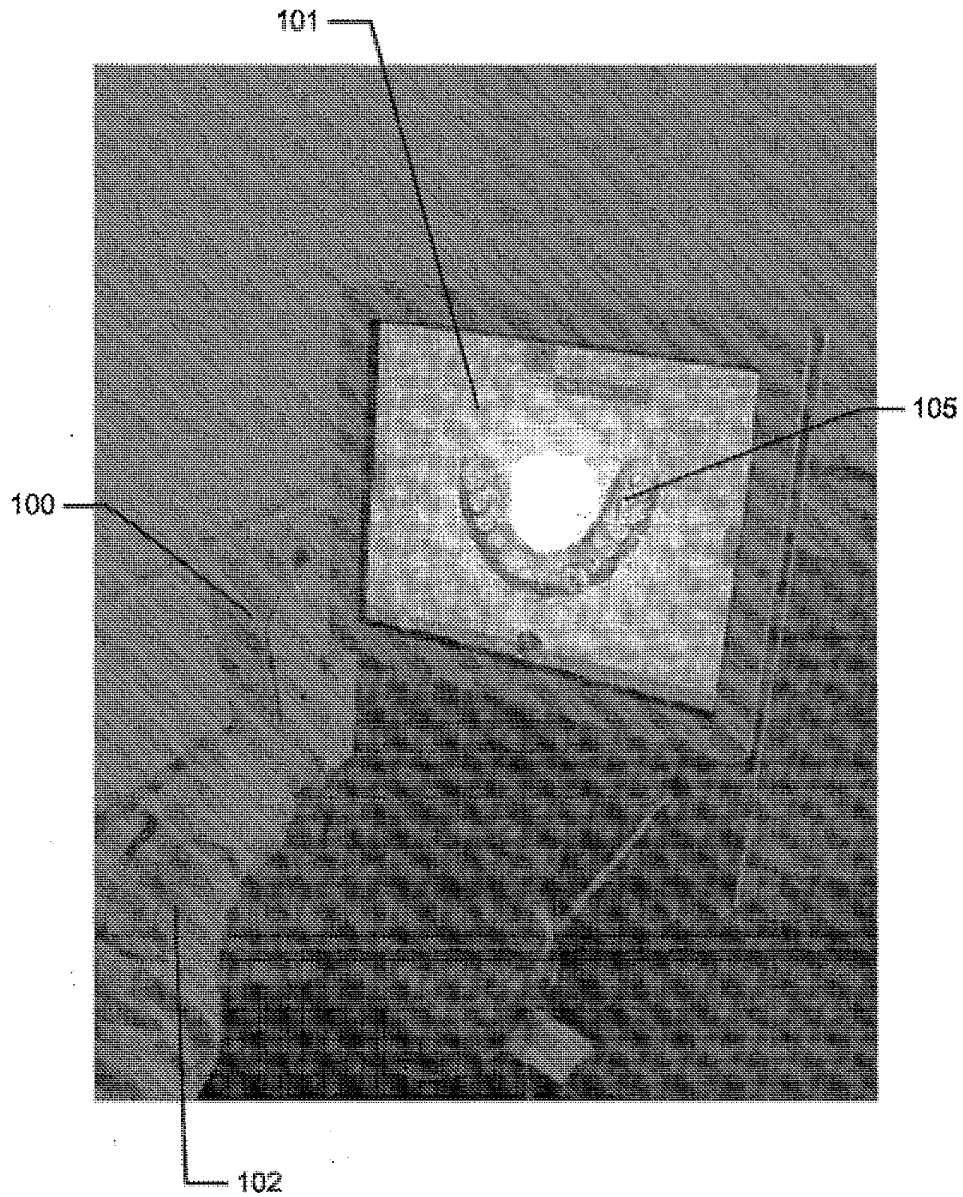

Fig. 2a)



3/5

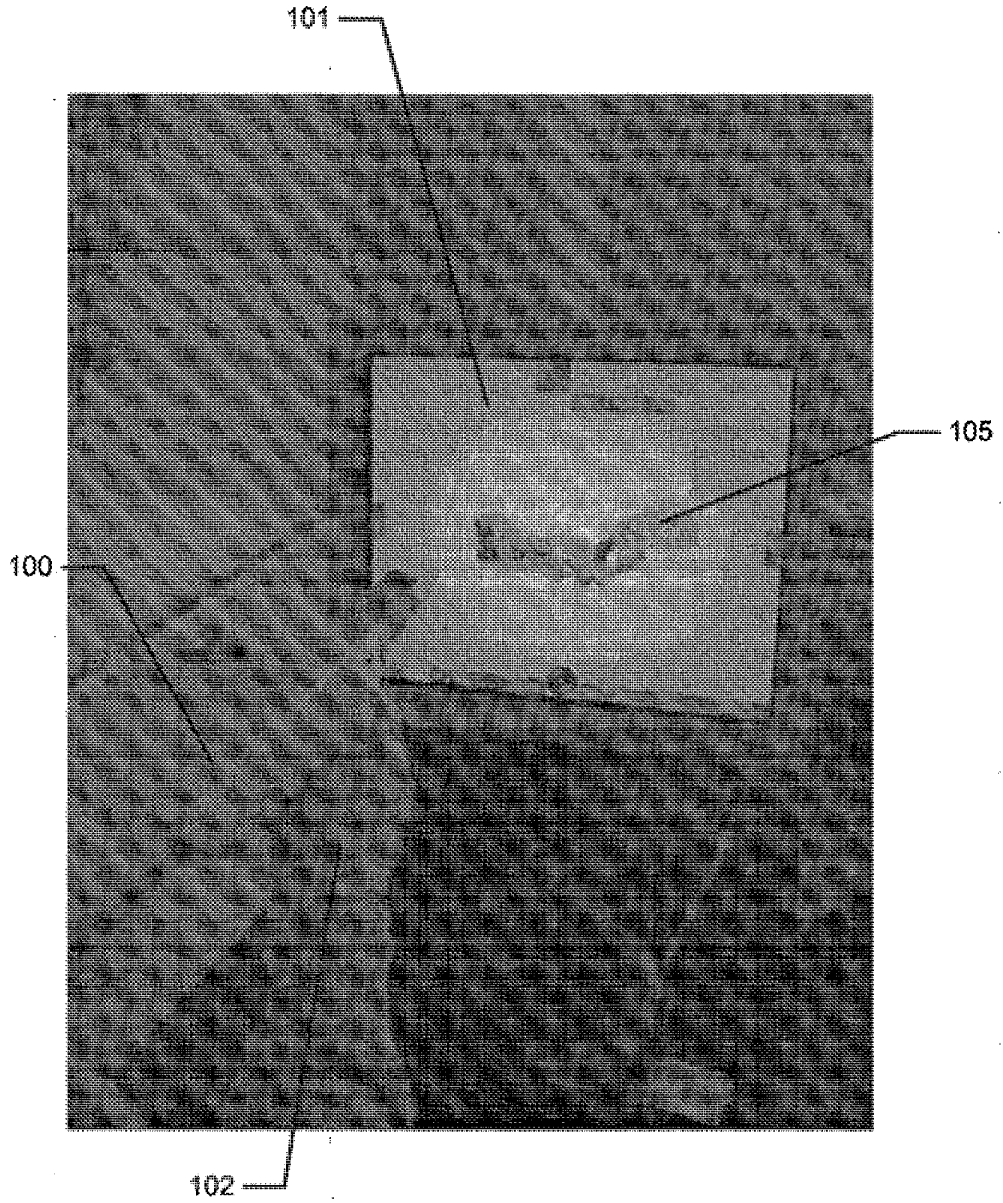

Fig. 2b)

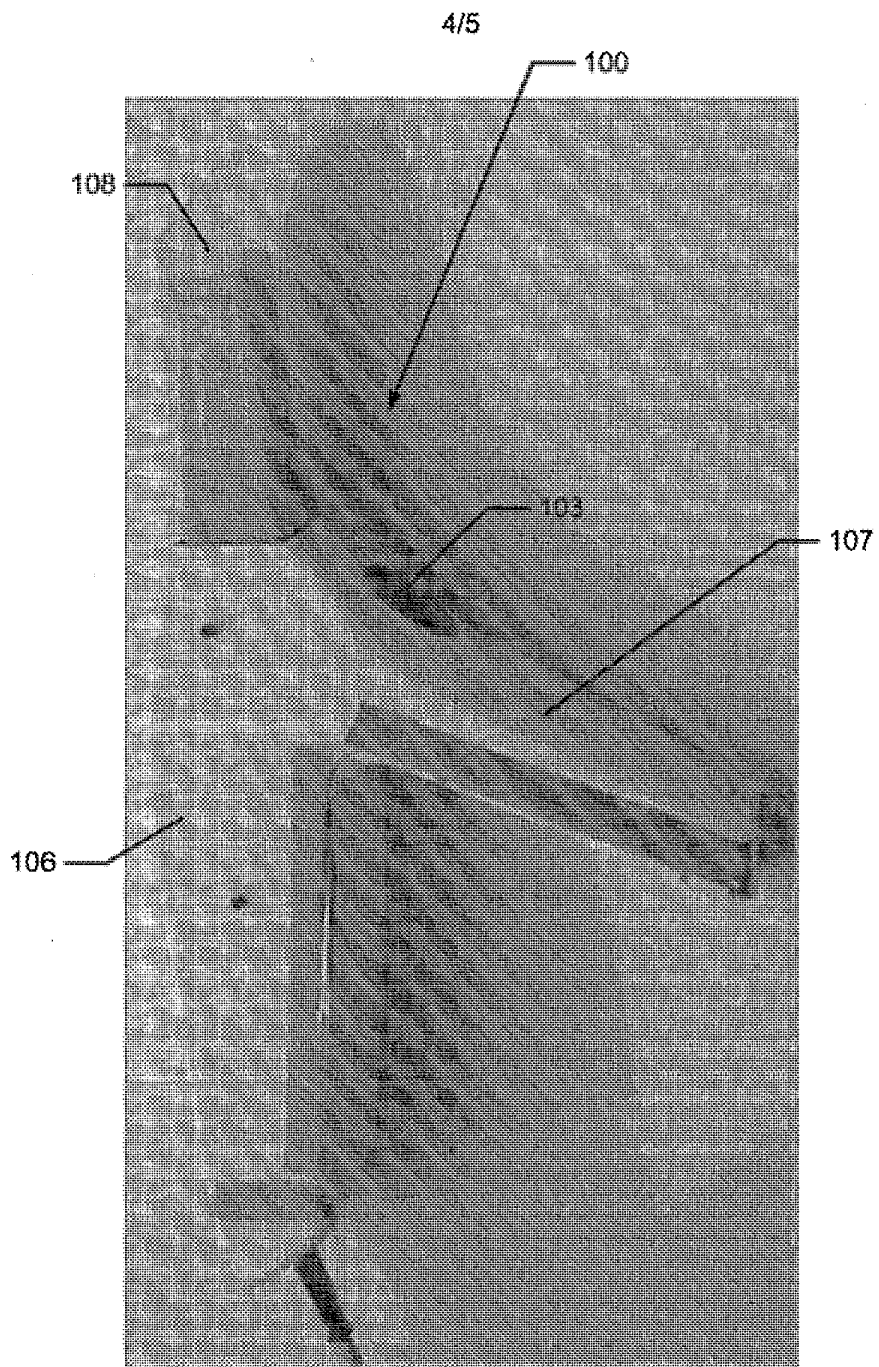

Fig. 3

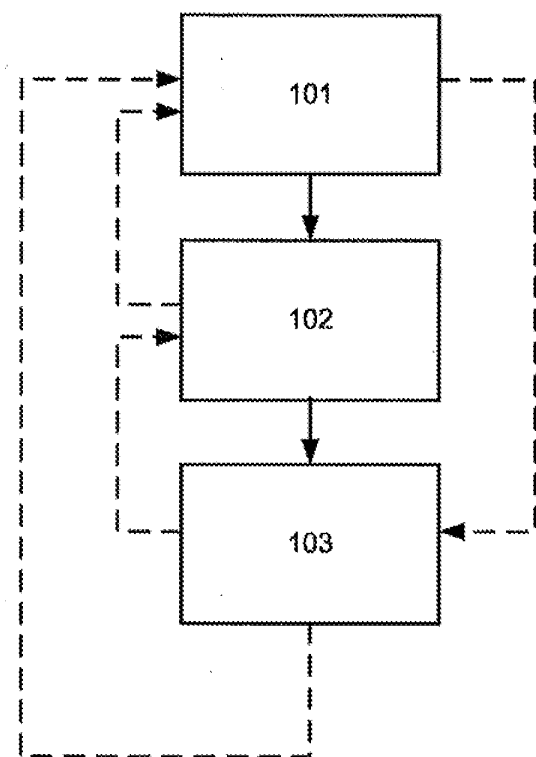

Fig. 4

**IN THE UNITED STATES PATENT AND TRADEMARK OFFICE**

In re Patent Application of	)	
	)	
Henrik ÖJELUND, et al.	)	<b>MAIL STOP: REISSUE</b>
	)	
Reissue of U.S. Patent No. 9,329,675:	)	
	)	
Issued: May 3, 2016	)	
	)	
For: SYSTEM WITH 3D USER INTERFACE	)	
INTEGRATION	)	

**GENERAL AUTHORIZATION FOR PETITIONS  
FOR EXTENSIONS OF TIME AND PAYMENT OF FEES**

Commissioner for Patents  
P.O. Box 1450  
Alexandria, VA 22313-1450

Sir:

In accordance with 37 C.F.R. § 1.136(a)(3), the U.S. Patent and Trademark Office is hereby provided with a general authorization to treat any concurrent or future reply requiring a petition for an extension of time for its timely submission as containing a request therefor for the appropriate length of time.

The Commissioner is hereby authorized to charge any appropriate fees under 37 C.F.R. § 1.17 that may be required by this paper, or any other submissions in this application, and to credit any overpayment, to Deposit Account No. 02-4800.

Respectfully submitted,  
  
BUCHANAN INGERSOLL & ROONEY PC

Date: July 30, 2019                      By: /Stephany G. Small/  
Stephany G. Small  
Registration No. 69,532

**Customer No. 21839**  
703 836 6620

Under the Paperwork Reduction Act of 1995, no persons are required to respond to a collection of information unless it displays a valid OMB control number.

REISSUE APPLICATION FEE TRANSMITTAL FORM							Docket Number (Optional)			
							0079124-000266			
Application as Filed – Part 1										
	(1) Claims in Patent	(2) Claims Filed in Reissue Application	(3) Number Extra	Micro Entity		Small Entity		Undiscounted		
				Rate (\$)	Fee (\$)	Rate (\$)	Fee (\$)	Rate (\$)	Fee (\$)	
Total Claims (37 CFR 1.16(f))	(A) 19	(B) 38	+ 18 =	x	=	x	=	x	100 =	1,800.00
Ind. Claims (37 CFR 1.16(h))	(C) 2	(D) 3	** 0 =	x	=	x	=	x	=	
Application Size Fee (37 CFR 1.16(s))	If the specification and drawings exceed 100 sheets of paper, the application size fee due is \$400 (\$200 for small entity, \$100 for micro entity) for each additional 50 sheets or fraction thereof. See 35 U.S.C. 41(a)(1)(G) and 37 CFR 1.16(s).									
	Filing Fee (37 CFR 1.16(e))								300.00	
	Search Fee (37 CFR 1.16(n))								600.00	
	Examination Fee (37 CFR 1.16(r))								2,200.00	
	Total Filing Fee								4,900.00	
Application as Amended – Part 2										
	(1) Claims Remaining After Amendment	(2) Highest Number Previously Paid For	(3) Extra Claims Present	Micro Entity		Small Entity		Undiscounted		
				Rate (\$)	Fee (\$)	Rate (\$)	Fee (\$)	Rate (\$)	Fee (\$)	
Total Claims (37 CFR 1.16(f))	***	****	=	x	=	x	=	x	=	
Ind. Claims (37 CFR 1.16(h))	***	****	=	x	=	x	=	x	=	
Application Size Fee (37 CFR 1.16(s))	If the specification and drawings exceed 100 sheets of paper, the application size fee due is \$400 (\$200 for small entity, \$100 for micro entity) for each additional 50 sheets or fraction thereof. See 35 U.S.C. 41(a)(1)(G) and 37 CFR 1.16(s).									
	Total Additional Fee									
<p>* Enter (B) – 20, or enter "0" if (B) is less than 20.  ** Enter (D) – minus 3, or enter "0" if (D) is less than 3.  *** After any cancellation of claims.  **** If the "Highest Number of Total Claims Previously Paid For" is less than 20, enter "20" in this space.  ***** If the "Highest Number of Independent Claims Previously Paid For" is less than 3, enter "3" in this space.</p> <p><input type="checkbox"/> Applicant asserts small entity status. See 37 CFR 1.27.  <input type="checkbox"/> Applicant certifies micro entity status. See 37 CFR 1.29.  Form PTO/SB/15A or B or equivalent must either be enclosed or have been submitted previously.</p> <p><input checked="" type="checkbox"/> The Director is hereby authorized to charge any additional fees under 37 CFR 1.16 or 1.17 which may be required, or credit any overpayment to Deposit Account No. 03-4800</p> <p><input type="checkbox"/> A check in the amount of \$ _____ to cover the filing/additional fee is enclosed.  <input checked="" type="checkbox"/> Payment made via EFS-Web.  <input type="checkbox"/> Payment by credit card. Form PTO-2038 is attached. WARNING: Information on this form may become public. Credit card information should not be included on this form. Provide credit card information and authorization on PTO-2038.</p> <p><u>/Stephanv G. Small/</u> _____ July 30, 2019 _____  Signature Date  Stephanv G. Small 69,532 _____  Typed or Printed Name Registration Number, if applicable  703-836-6620 _____  Telephone Number</p>										

This collection of information is required by 37 CFR 1.16. The information is required to obtain or retain a benefit by the public which is to file (and by the USPTO to process) an application. Confidentiality is governed by 35 U.S.C. 122 and 37 CFR 1.11, 1.14 and 41.6. This collection is estimated to take 12 minutes to complete, including gathering, preparing, and submitting the completed application form to the USPTO. Time will vary depending upon the individual case. Any comments on the amount of time you require to complete this form and/or suggestions for reducing this burden, should be sent to the Chief Information Officer, U.S. Patent and Trademark Office, U.S. Department of Commerce, P.O. Box 1450, Alexandria, VA 22313-1450. DO NOT SEND FEES OR COMPLETED FORMS TO THIS ADDRESS. SEND TO: Commissioner for Patents, P.O. Box 1450, Alexandria, VA 22313-1450.

If you need assistance in completing the form, call 1-800-PTO-8199 and select option 2.

Under the Paperwork Reduction Act of 1995, no persons are required to respond to a collection of information unless it displays a valid OMB control number.

**TRANSMITTAL FOR POWER OF ATTORNEY TO ONE OR MORE  
 REGISTERED PRACTITIONERS**

**NOTE:** This form is to be submitted with the Power of Attorney by Applicant form (PTO/AIA/82B or equivalent) to identify the application to which the Power of Attorney is directed, in accordance with 37 CFR 1.5. If the Power of Attorney by Applicant form is not accompanied by this transmittal form or an equivalent, the Power of Attorney will not be recognized in the application.

Application Number	Unassigned
Filing Date	July 30, 2019
First Named Inventor	Henrik ÖJELUND
Title	SYSTEM WITH 3D USER INTERFACE INTEGRATION
Art Unit	Unassigned
Examiner Name	Unassigned
Attorney Docket Number	0079124-000266

**SIGNATURE of Applicant or Patent Practitioner**

Signature	/Stephany G. Small/	Date	July 30, 2019
Name	Stephany G. Small	Telephone	703-836-6620
Registration Number	69,532		

**NOTE:** This form must be signed in accordance with 37 CFR 1.33. See 37 CFR 1.4(d) for signature requirements and certifications.

\*Total of      forms are submitted.

This collection of information is required by 37 CFR 1.31, 1.32 and 1.33. The information is required to obtain or retain a benefit by the public which is to file (and by the USPTO to process) an application. Confidentiality is governed by 35 U.S.C. 122 and 37 CFR 1.11 and 1.14. This collection is estimated to take 3 minutes to complete, including gathering, preparing, and submitting the completed application form to the USPTO. Time will vary depending upon the individual case. Any comments on the amount of time you require to complete this form and/or suggestions for reducing this burden, should be sent to the Chief Information Officer, U.S. Patent and Trademark Office, U.S. Department of Commerce, P.O. Box 1450, Alexandria, VA 22313-1450. DO NOT SEND FEES OR COMPLETED FORMS TO THIS ADDRESS. **SEND TO: Commissioner for Patents, P.O. Box 1450, Alexandria, VA 22313-1450.**

*If you need assistance in completing the form, call 1-800-PTO-9199 and select option 2.*

## POWER OF ATTORNEY BY APPLICANT

I hereby revoke all previous powers of attorney given in the application identified in either the attached transmittal letter or the boxes below.

Application Number	Filing Date

(Note: The boxes above may be left blank if information is provided on form PTO/AIA/82A.)

- I hereby appoint the Patent Practitioner(s) associated with the following Customer Number as my/our attorney(s) or agent(s), and to transact all business in the United States Patent and Trademark Office connected therewith for the application referenced in the attached transmittal letter (form PTO/AIA/82A) or identified above: 21839
- OR
- I hereby appoint Practitioner(s) named in the attached list (form PTO/AIA/82C) as my/our attorney(s) or agent(s), and to transact all business in the United States Patent and Trademark Office connected therewith for the patent application referenced in the attached transmittal letter (form PTO/AIA/82A) or identified above. (Note: Complete form PTO/AIA/82C.)

Please recognize or change the correspondence address for the application identified in the attached transmittal letter or the boxes above to:

- The address associated with the above-mentioned Customer Number
- OR
- The address associated with Customer Number: 21839
- OR

Firm or Individual Name			
Address			
City	State	Zip	
Country			
Telephone	Email		

I am the Applicant (if the Applicant is a juristic entity, list the Applicant name in the box):

3Shape A/S

- Inventor or Joint Inventor (title not required below)
- Legal Representative of a Deceased or Legally Incapacitated Inventor (title not required below)
- Assignee or Person to Whom the Inventor is Under an Obligation to Assign (provide signer's title if applicant is a juristic entity)
- Person Who Otherwise Shows Sufficient Proprietary Interest (e.g., a petition under 37 CFR 1.46(b)(2) was granted in the application or is concurrently being filed with this document) (provide signer's title if applicant is a juristic entity)

### SIGNATURE of Applicant for Patent

The undersigned (whose title is supplied below) is authorized to act on behalf of the applicant (e.g., where the applicant is a juristic entity).

Signature	Date (Optional)
	11 MAY 2012
Name	
HETTE CARLSTEDT	
Title	
GENERAL COUNSEL	

**NOTE:** Signature - This form must be signed by the applicant in accordance with 37 CFR 1.33. See 37 CFR 1.4 for signature requirements and certifications. If more than one applicant, use multiple forms.

Total of \_\_\_\_\_ forms are submitted.

This collection of information is required by 37 CFR 1.131, 1.33, and 1.35. The information is required to obtain or retain a benefit by the public which is to be rendered by the USPTO to process an application. Confidentiality is governed by 35 U.S.C. 122 and 37 CFR 1.11 and 1.14. This collection is estimated to take 3 minutes to complete, including gathering, preparing, and submitting the completed application form to the USPTO. Time will vary depending upon the individual case. Any comments on the amount of time you require to complete this form and/or suggestions for reducing this burden, should be sent to the Chief Information Officer, U.S. Patent and Trademark Office, U.S. Department of Commerce, P.O. Box 1450, Alexandria, VA 22313-1450. DO NOT SEND FEES OR COMPLETED FORMS TO THIS ADDRESS. SEND TO: Commissioner for Patents, P.O. Box 1450, Alexandria, VA 22313-1450.

If you need assistance in completing the form, call 1-800-PTO-9199 and select option 2.

Under the Paperwork Reduction Act of 1995, no persons are required to respond to a collection of information unless it displays a valid OMB control number.

**STATEMENT UNDER 37 CFR 3.73(c)**

Applicant/Patent Owner: 3SHAPE A/S  
Application No./Patent No.: 9,329,675 Filed/Issue Date: May 3, 2016  
Titled: SYSTEM WITH 3D USER INTERFACE INTEGRATION  
3SHAPE A/S, a corporation  
(Name of Assignee) (Type of Assignee, e.g., corporation, partnership, university, government agency, etc.)

states that, for the patent application/patent identified above, it is (choose one of options 1, 2, 3 or 4 below):

- 1.  The assignee of the entire right, title, and interest.
- 2.  An assignee of less than the entire right, title, and interest (check applicable box):
  - The extent (by percentage) of its ownership interest is \_\_\_\_\_%. Additional Statement(s) by the owners holding the balance of the interest must be submitted to account for 100% of the ownership interest.
  - There are unspecified percentages of ownership. The other parties, including inventors, who together own the entire right, title and interest are:

Additional Statement(s) by the owner(s) holding the balance of the interest must be submitted to account for the entire right, title, and interest.

- 3.  The assignee of an undivided interest in the entirety (a complete assignment from one of the joint inventors was made). The other parties, including inventors, who together own the entire right, title, and interest are:

Additional Statement(s) by the owner(s) holding the balance of the interest must be submitted to account for the entire right, title, and interest.

- 4.  The recipient, via a court proceeding or the like (e.g., bankruptcy, probate), of an undivided interest in the entirety (a complete transfer of ownership interest was made). The certified document(s) showing the transfer is attached.

The interest identified in option 1, 2 or 3 above (not option 4) is evidenced by either (choose one of options A or B below):

- A.  An assignment from the inventor(s) of the patent application/patent identified above. The assignment was recorded in the United States Patent and Trademark Office at Reel 031241, Frame 0637, or for which a copy thereof is attached.
- B.  A chain of title from the inventor(s), of the patent application/patent identified above, to the current assignee as follows:

1. From: \_\_\_\_\_ To: \_\_\_\_\_

The document was recorded in the United States Patent and Trademark Office at  
Reel \_\_\_\_\_, Frame \_\_\_\_\_, or for which a copy thereof is attached.

2. From: \_\_\_\_\_ To: \_\_\_\_\_

The document was recorded in the United States Patent and Trademark Office at  
Reel \_\_\_\_\_, Frame \_\_\_\_\_, or for which a copy thereof is attached.

[Page 1 of 2]

This collection of information is required by 37 CFR 3.73(b). The information is required to obtain or retain a benefit by the public which is to file (and by the USPTO to process) an application. Confidentiality is governed by 35 U.S.C. 122 and 37 CFR 1.11 and 1.14. This collection is estimated to take 12 minutes to complete, including gathering, preparing, and submitting the completed application form to the USPTO. Time will vary depending upon the individual case. Any comments on the amount of time you require to complete this form and/or suggestions for reducing this burden, should be sent to the Chief Information Officer, U.S. Patent and Trademark Office, U.S. Department of Commerce, P.O. Box 1450, Alexandria, VA 22313-1450. DO NOT SEND FEES OR COMPLETED FORMS TO THIS ADDRESS. **SEND TO: Commissioner for Patents, P.O. Box 1450, Alexandria, VA 22313-1450.**

*If you need assistance in completing the form, call 1-800-PTO-9199 and select option 2.*



**STATEMENT UNDER 37 CFR 3.73(c)**

3. From: \_\_\_\_\_ To: \_\_\_\_\_

The document was recorded in the United States Patent and Trademark Office at  
Reel \_\_\_\_\_, Frame \_\_\_\_\_, or for which a copy thereof is attached.

4. From: \_\_\_\_\_ To: \_\_\_\_\_

The document was recorded in the United States Patent and Trademark Office at  
Reel \_\_\_\_\_, Frame \_\_\_\_\_, or for which a copy thereof is attached.

5. From: \_\_\_\_\_ To: \_\_\_\_\_

The document was recorded in the United States Patent and Trademark Office at  
Reel \_\_\_\_\_, Frame \_\_\_\_\_, or for which a copy thereof is attached.

6. From: \_\_\_\_\_ To: \_\_\_\_\_

The document was recorded in the United States Patent and Trademark Office at  
Reel \_\_\_\_\_, Frame \_\_\_\_\_, or for which a copy thereof is attached.

Additional documents in the chain of title are listed on a supplemental sheet(s).

As required by 37 CFR 3.73(c)(1)(i), the documentary evidence of the chain of title from the original owner to the assignee was, or concurrently is being, submitted for recordation pursuant to 37 CFR 3.11.

[NOTE: A separate copy (i.e., a true copy of the original assignment document(s)) must be submitted to Assignment Division in accordance with 37 CFR Part 3, to record the assignment in the records of the USPTO. See MPEP 302.08]

The undersigned (whose title is supplied below) is authorized to act on behalf of the assignee.

/Stephany G. Small/

July 30, 2019

Signature

Date

Stephany G. Small

69,532

Printed or Typed Name

Title or Registration Number

## Privacy Act Statement

The **Privacy Act of 1974 (P.L. 93-579)** requires that you be given certain information in connection with your submission of the attached form related to a patent application or patent. Accordingly, pursuant to the requirements of the Act, please be advised that: (1) the general authority for the collection of this information is 35 U.S.C. 2(b)(2); (2) furnishing of the information solicited is voluntary; and (3) the principal purpose for which the information is used by the U.S. Patent and Trademark Office is to process and/or examine your submission related to a patent application or patent. If you do not furnish the requested information, the U.S. Patent and Trademark Office may not be able to process and/or examine your submission, which may result in termination of proceedings or abandonment of the application or expiration of the patent.

The information provided by you in this form will be subject to the following routine uses:

1. The information on this form will be treated confidentially to the extent allowed under the Freedom of Information Act (5 U.S.C. 552) and the Privacy Act (5 U.S.C. 552a). Records from this system of records may be disclosed to the Department of Justice to determine whether disclosure of these records is required by the Freedom of Information Act.
2. A record from this system of records may be disclosed, as a routine use, in the course of presenting evidence to a court, magistrate, or administrative tribunal, including disclosures to opposing counsel in the course of settlement negotiations.
3. A record in this system of records may be disclosed, as a routine use, to a Member of Congress submitting a request involving an individual, to whom the record pertains, when the individual has requested assistance from the Member with respect to the subject matter of the record.
4. A record in this system of records may be disclosed, as a routine use, to a contractor of the Agency having need for the information in order to perform a contract. Recipients of information shall be required to comply with the requirements of the Privacy Act of 1974, as amended, pursuant to 5 U.S.C. 552a(m).
5. A record related to an International Application filed under the Patent Cooperation Treaty in this system of records may be disclosed, as a routine use, to the International Bureau of the World Intellectual Property Organization, pursuant to the Patent Cooperation Treaty.
6. A record in this system of records may be disclosed, as a routine use, to another federal agency for purposes of National Security review (35 U.S.C. 181) and for review pursuant to the Atomic Energy Act (42 U.S.C. 218(c)).
7. A record from this system of records may be disclosed, as a routine use, to the Administrator, General Services, or his/her designee, during an inspection of records conducted by GSA as part of that agency's responsibility to recommend improvements in records management practices and programs, under authority of 44 U.S.C. 2904 and 2906. Such disclosure shall be made in accordance with the GSA regulations governing inspection of records for this purpose, and any other relevant (*i.e.*, GSA or Commerce) directive. Such disclosure shall not be used to make determinations about individuals.
8. A record from this system of records may be disclosed, as a routine use, to the public after either publication of the application pursuant to 35 U.S.C. 122(b) or issuance of a patent pursuant to 35 U.S.C. 151. Further, a record may be disclosed, subject to the limitations of 37 CFR 1.14, as a routine use, to the public if the record was filed in an application which became abandoned or in which the proceedings were terminated and which application is referenced by either a published application, an application open to public inspection or an issued patent.
9. A record from this system of records may be disclosed, as a routine use, to a Federal, State, or local law enforcement agency, if the USPTO becomes aware of a violation or potential violation of law or regulation.

Under the Paperwork Reduction Act of 1995, no persons are required to respond to a collection of information unless it displays a valid OMB control number.

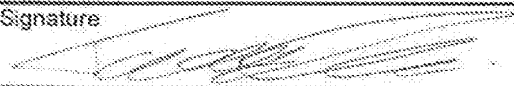
<b>REISSUE APPLICATION: CONSENT OF ASSIGNEE; STATEMENT OF NON-ASSIGNMENT</b>		Docket Number (Optional) 0079124-000266
This is part of the application for a reissue patent based on the original patent identified below.		
Name of Patentee(s) 3SHAPE A/S		
Patent Number 9,329,675	Date Patent Issued May 3, 2016	
Title of Invention SYSTEM WITH 3D USER INTERFACE INTEGRATION		
<p>1. <input checked="" type="checkbox"/> Filed herein is a statement under 37 CFR 3.73(c). (Form PTO/AIA/96)</p> <p>2. <input type="checkbox"/> Ownership of the patent is in the inventor(s), and no assignment of the patent is in effect.</p> <p>One of boxes 1 or 2 above must be checked. If multiple assignees, complete this form for each assignee. If box 2 is checked, skip the next entry and go directly to "Name of Assignee."</p> <p>The written consent of all assignees and inventors owning an undivided interest in the original patent is included in this application for reissue.</p>		
The assignee(s) owning an undivided interest in said original patent is/are 3SHAPE A/S and the assignee(s) consents to the accompanying application for reissue.		
Name of assignee/inventor (if not assigned) 3SHAPE A/S		
Signature 	Date 29. 04. 2019	
Typed or printed name and title of person signing for assignee (if assigned) TAIS CLAUSEN, Co-CEO (3SHAPE A/S)		

This collection of information is required by 37 CFR 1.172. The information is required to obtain or retain a benefit by the public which is to file (and by the USPTO to process) an application. Confidentiality is governed by 35 U.S.C. 122 and 37 CFR 1.14. This collection is estimated to take 8 minutes to complete, including gathering, preparing, and submitting the completed application form to the USPTO. Time will vary depending upon the individual case. Any comments on the amount of time you require to complete this form and/or suggestions for reducing this burden, should be sent to the Chief Information Officer, U.S. Patent and Trademark Office, U.S. Department of Commerce, P.O. Box 1450, Alexandria, VA 22313-1450. DO NOT SEND FEES OR COMPLETED FORMS TO THIS ADDRESS. SEND TO: Commissioner for Patents, P.O. Box 1450, Alexandria, VA 22313-1450.

If you need assistance in completing the form, call 1-800-PTO-9199 and select option 2.

## Privacy Act Statement

The **Privacy Act of 1974 (P.L. 93-579)** requires that you be given certain information in connection with your submission of the attached form related to a patent application or patent. Accordingly, pursuant to the requirements of the Act, please be advised that: (1) the general authority for the collection of this information is 35 U.S.C. 2(b)(2); (2) furnishing of the information solicited is voluntary; and (3) the principal purpose for which the information is used by the U.S. Patent and Trademark Office is to process and/or examine your submission related to a patent application or patent. If you do not furnish the requested information, the U.S. Patent and Trademark Office may not be able to process and/or examine your submission, which may result in termination of proceedings or abandonment of the application or expiration of the patent.

The information provided by you in this form will be subject to the following routine uses:

1. The information on this form will be treated confidentially to the extent allowed under the Freedom of Information Act (5 U.S.C. 552) and the Privacy Act (5 U.S.C. 552a). Records from this system of records may be disclosed to the Department of Justice to determine whether disclosure of these records is required by the Freedom of Information Act.
2. A record from this system of records may be disclosed, as a routine use, in the course of presenting evidence to a court, magistrate, or administrative tribunal, including disclosures to opposing counsel in the course of settlement negotiations.
3. A record in this system of records may be disclosed, as a routine use, to a Member of Congress submitting a request involving an individual, to whom the record pertains, when the individual has requested assistance from the Member with respect to the subject matter of the record.
4. A record in this system of records may be disclosed, as a routine use, to a contractor of the Agency having need for the information in order to perform a contract. Recipients of information shall be required to comply with the requirements of the Privacy Act of 1974, as amended, pursuant to 5 U.S.C. 552a(m).
5. A record related to an International Application filed under the Patent Cooperation Treaty in this system of records may be disclosed, as a routine use, to the International Bureau of the World Intellectual Property Organization, pursuant to the Patent Cooperation Treaty.
6. A record in this system of records may be disclosed, as a routine use, to another federal agency for purposes of National Security review (35 U.S.C. 181) and for review pursuant to the Atomic Energy Act (42 U.S.C. 218(c)).
7. A record from this system of records may be disclosed, as a routine use, to the Administrator, General Services, or his/her designee, during an inspection of records conducted by GSA as part of that agency's responsibility to recommend improvements in records management practices and programs, under authority of 44 U.S.C. 2904 and 2906. Such disclosure shall be made in accordance with the GSA regulations governing inspection of records for this purpose, and any other relevant (i.e., GSA or Commerce) directive. Such disclosure shall not be used to make determinations about individuals.
8. A record from this system of records may be disclosed, as a routine use, to the public after either publication of the application pursuant to 35 U.S.C. 122(b) or issuance of a patent pursuant to 35 U.S.C. 151. Further, a record may be disclosed, subject to the limitations of 37 CFR 1.14, as a routine use, to the public if the record was filed in an application which became abandoned or in which the proceedings were terminated and which application is referenced by either a published application, an application open to public inspection or an issued patent.
9. A record from this system of records may be disclosed, as a routine use, to a Federal, State, or local law enforcement agency, if the USPTO becomes aware of a violation or potential violation of law or regulation.

<b>REISSUE APPLICATION DECLARATION BY THE ASSIGNEE</b>		Docket Number (optional) 0079124-000266	
I hereby declare that: The residence and mailing address of the inventor or joint inventors are stated below.			
Name of the Assignee: 3SHAPE A/S			
I am authorized to act on behalf of the assignee (if the assignee is a juristic entity). The entire title to the patent identified below is vested in said assignee, or if there are multiple assignees/owners, all assignees/owners have executed a Reissue Application Declaration to account for the entire title of the patent identified below.			
Inventor <b>Henrik ÖJELUND</b>			
Residence: City Lyngby	State	Country DK	
Mailing Address Kulsvierparken 55			
City Lyngby	State	Zip DK-2600	Country DK
<input checked="" type="checkbox"/> Additional inventors are named on separately numbered sheets attached hereto.			
Patent Number <b>9,329,675</b>		Patent Issue Date <b>May 3, 2016</b>	
I believe said inventor(s) to be the original inventor or original joint inventors of the subject matter which is described and claimed in said patent, for which a reissue patent is sought on the invention titled:			
SYSTEM WITH 3D USER INTERFACE INTEGRATION			
the specification of which			
<input checked="" type="checkbox"/> is attached hereto.			
<input type="checkbox"/> was filed on _____ at reissue application number _____.			
The above-identified application was made or authorized to be made by me.			
I hereby acknowledge that any willful false statement made in this declaration is punishable under 18 U.S.C. 1001 by fine or imprisonment of not more than five (5) years, or both.			
I believe the original patent to be wholly or partly inoperative or invalid, for the reasons described below. (Check all boxes that apply.)			
<input type="checkbox"/> by reason of a defective specification or drawing.			
<input checked="" type="checkbox"/> by reason of the patentee claiming more or less than he had the right to claim in the patent.			
<input type="checkbox"/> by reason of other errors.			

This collection of information is required by 37 CFR 1.175. The information is required to obtain or retain a benefit by the public which is to file (and by the USPTO to process) an application. Confidentiality is governed by 35 U.S.C. 122 and 37 CFR 1.11 and 1.14. This collection is estimated to take 30 minutes to complete, including gathering, preparing, and submitting the completed application form to the USPTO. Time will vary depending upon the individual case. Any comments on the amount of time you require to complete this form and/or suggestions for reducing this burden, should be sent to the Chief Information Officer, U.S. Patent and Trademark Office, U.S. Department of Commerce, P.O. Box 1480, Alexandria, VA 22313-1480. DO NOT SEND FEES OR COMPLETED FORMS TO THIS ADDRESS. SEND TO: Commissioner for Patents, P.O. Box 1480, Alexandria, VA 22313-1480.

If you need assistance in completing the form, call 1-800-PTO-9199 and select option 2.

REISSUE APPLICATION DECLARATION BY THE ASSIGNEE		Docket Number (Optional) 0079124-0002	
<p>At least one error upon which reissue is based is described below. If the reissue is a broadening reissue, a claim that the application seeks to broaden must be identified and the box below must be checked:</p> <p>A claim is being added to correct an error wherein patent owner failed to previously present a narrower claim reciting that the at least one motion sensor is an accelerometer, gyro, or magnetometer. Claim 20 recites this subject matter.</p> <p style="text-align: center;">[Attach additional sheets, if needed.]</p> <p><input type="checkbox"/> The application for the original patent was filed under 37 CFR 1.46 by the assignee of the entire interest.</p>			
I hereby appoint:			
<input checked="" type="checkbox"/> Practitioners associated with Customer Number:		21839	
OR			
<input type="checkbox"/> Practitioner(s) named below:			
Name		Registration Number	
as my/our attorney(s) or agent(s) to prosecute the application identified above, and to transact all business in the United States Patent and Trademark Office connected therewith.			
Correspondence Address: Direct all communications about the application to:			
<input checked="" type="checkbox"/> The address associated with Customer Number:		21839	
OR			
<input type="checkbox"/> Firm or Individual Name			
Address			
City		State	Zip
Country			
Telephone		Email	
<b>WARNING:</b>			
<p>Petitioner/applicant is cautioned to avoid submitting personal information in documents filed in a patent application that may contribute to identity theft. Personal information such as social security numbers, bank account numbers, or credit card numbers (other than a check or credit card authorization form PTO-2038 submitted for payment purposes) is never required by the USPTO to support a petition or an application. If this type of personal information is included in documents submitted to the USPTO, petitioners/applicants should consider redacting such personal information from the documents before submitting them to the USPTO. Petitioner/applicant is advised that the record of a patent application is available to the public after publication of the application (unless a non-publication request in compliance with 37 CFR 1.213(a) is made in the application) or issuance of a patent. Furthermore, the record from an abandoned application may also be available to the public if the application is referenced in a published application or an issued patent (see 37 CFR 1.14). Checks and credit card authorization forms PTO-2038 submitted for payment purposes are not retained in the application file and therefore are not publicly available.</p>			
Signature 		Date (Optional) 30.07.2019	
Legal name of person signing Tais Clausen			
Address of Assignee 3Shape A/S, Holmens Kanal 7, 4. sal, Copenhagen K, DK-1060, DENMARK			

## Privacy Act Statement

The Privacy Act of 1974 (P.L. 93-579) requires that you be given certain information in connection with your submission of the attached form related to a patent application or patent. Accordingly, pursuant to the requirements of the Act, please be advised that: (1) the general authority for the collection of this information is 35 U.S.C. 2(b)(2); (2) furnishing of the information solicited is voluntary; and (3) the principal purpose for which the information is used by the U.S. Patent and Trademark Office is to process and/or examine your submission related to a patent application or patent. If you do not furnish the requested information, the U.S. Patent and Trademark Office may not be able to process and/or examine your submission, which may result in termination of proceedings or abandonment of the application or expiration of the patent.

The information provided by you in this form will be subject to the following routine uses:

1. The information on this form will be treated confidentially to the extent allowed under the Freedom of Information Act (5 U.S.C. 552) and the Privacy Act (5 U.S.C. 552a). Records from this system of records may be disclosed to the Department of Justice to determine whether disclosure of these records is required by the Freedom of Information Act.
2. A record from this system of records may be disclosed, as a routine use, in the course of presenting evidence to a court, magistrate, or administrative tribunal, including disclosures to opposing counsel in the course of settlement negotiations.
3. A record in this system of records may be disclosed, as a routine use, to a Member of Congress submitting a request involving an individual, to whom the record pertains, when the individual has requested assistance from the Member with respect to the subject matter of the record.
4. A record in this system of records may be disclosed, as a routine use, to a contractor of the Agency having need for the information in order to perform a contract. Recipients of information shall be required to comply with the requirements of the Privacy Act of 1974, as amended, pursuant to 5 U.S.C. 552a(m).
5. A record related to an International Application filed under the Patent Cooperation Treaty in this system of records may be disclosed, as a routine use, to the International Bureau of the World Intellectual Property Organization, pursuant to the Patent Cooperation Treaty.
6. A record in this system of records may be disclosed, as a routine use, to another federal agency for purposes of National Security review (35 U.S.C. 181) and for review pursuant to the Atomic Energy Act (42 U.S.C. 218(c)).
7. A record from this system of records may be disclosed, as a routine use, to the Administrator, General Services, or his/her designee, during an inspection of records conducted by GSA as part of that agency's responsibility to recommend improvements in records management practices and programs, under authority of 44 U.S.C. 2904 and 2906. Such disclosure shall be made in accordance with the GSA regulations governing inspection of records for this purpose, and any other relevant (i.e., GSA or Commerce) directive. Such disclosure shall not be used to make determinations about individuals.
8. A record from this system of records may be disclosed, as a routine use, to the public after either publication of the application pursuant to 35 U.S.C. 122(b) or issuance of a patent pursuant to 35 U.S.C. 151. Further, a record may be disclosed, subject to the limitations of 37 CFR 1.14, as a routine use, to the public if the record was filed in an application which became abandoned or in which the proceedings were terminated and which application is referenced by either a published application, an application open to public inspection or an issued patent.
9. A record from this system of records may be disclosed, as a routine use, to a Federal, State, or local law enforcement agency, if the USPTO becomes aware of a violation or potential violation of law or regulation.

**SUPPLEMENTAL SHEET FOR DECLARATION****ADDITIONAL INVENTOR(S)**

Supplemental Sheet (for PTO/AIA/08,09)

Page 3 of 3**Legal Name of Additional Joint Inventor, if any:**

(E.g., Given Name (first and middle (if any)) and Family Name or Surname)

David FISCHER

Inventor's  
Signature

Date (Optional)

Residence: City **Stenløse**

State

Country **DK****Rådyleddet 16**

Mailing Address

City **Stenløse**

State

Zip **DK-3660**Country **DK****Legal Name of Additional Joint Inventor, if any:**

(E.g., Given Name (first and middle (if any)) and Family Name or Surname)

Karl-Josef HOLLENBECK

Inventor's  
Signature

Date (Optional)

Residence: City **København Ø**

State

Country **DK****Ribegade 12 3.th**

Mailing Address

City **København Ø**

State

Zip **DK-2100**Country **DK****Legal Name of Additional Joint Inventor, if any:**

(E.g., Given Name (first and middle (if any)) and Family Name or Surname)

Inventor's  
Signature

Date (Optional)

Residence: City

State

Country

Mailing Address

City

State

Zip

Country

This collection of information is required by 35 U.S.C. 115 and 37 CFR 1.63. The information is required to obtain or retain a benefit by the public which is to file (and by the USPTO to process) an application. Confidentiality is governed by 35 U.S.C. 122 and 37 CFR 1.11 and 1.14. This collection is estimated to take 21 minutes to complete, including gathering, preparing, and submitting the completed application form to the USPTO. Time will vary depending upon the individual case. Any comments on the amount of time you require to complete this form and/or suggestions for reducing this burden, should be sent to the Chief Information Officer, U.S. Patent and Trademark Office, U.S. Department of Commerce, P.O. Box 1450, Alexandria, VA 22313-1450. DO NOT SEND FEES OR COMPLETED FORMS TO THIS ADDRESS. SEND TO: Commissioner for Patents, P.O. Box 1450, Alexandria, VA 22313-1450.

If you need assistance in completing the form, call 1-800-PTO-9199 (1-800-766-9199) and select option 2.



**IN THE UNITED STATES PATENT AND TRADEMARK OFFICE**

In re Patent Application of )  
Henrik ÖJELUND et al. ) **MAIL STOP: REISSUE**  
Reissue of U.S. Patent No. 9,329,675 )  
Issued: May 3, 2016 )  
For: SYSTEM WITH 3D USER INTERFACE )  
INTEGRATION )

**PRELIMINARY AMENDMENT**

Commissioner for Patents  
P.O. Box 1450  
Alexandria, VA 22313-1450

Commissioner:

Prior to examination of the above-captioned patent application, kindly amend the application as follows:

## **AMENDMENTS TO THE CLAIMS:**

The following listing of claims will replace all prior versions and listings of claims in this application.

## **LISTING OF CLAIMS:**

1. (amended) A scanning system for scanning a 3D environment, the scanning system comprising:  
a handheld device including an optical scanner, wherein the 3D environment to be scanned is selected by pointing the optical scanner at the 3D environment; and  
at least one display remotely connected to the handheld device,  
wherein the handheld device is adapted for performing at least one scanning action in a physical 3D environment, and the at least one display is adapted for visually representing the physical 3D environment; and  
the handheld device includes a 3D user interface for remotely controlling the display to adjust the view with which the 3D environment is represented on the display,  
wherein the handheld device comprises at least one motion sensor, and  
wherein the at least one motion sensor is a sensor that directly detects motion.
2. (amended) [A] The scanning system according to claim 1, wherein the handheld device is adapted to record the 3D geometry of the 3D environment.

3. (amended) [A] The scanning system according to claim 1, wherein the handheld device includes an actuator [means] for manually switching between performing the at least one scanning action and remotely controlling the view.

Please cancel Claim 4.

5. (amended) The scanning system according to claim [4] 1, wherein the view of the 3D environment represented in the at least one display is at least partly determined by the at least one motion sensor.
6. (amended) The scanning system according to claim [4] 1, wherein functionality of the 3D user interface comprises a use of gestures.
7. (amended) The scanning system according to claim 6, wherein the gestures are detected by the at least one motion sensor.
8. (amended) The scanning system according to claim [4] 1, wherein the [user-interface is other than the at least one motion sensor] handheld device further comprises at least one of an infrared sensor, a range sensor, or a proximity sensor.

9. (amended) The scanning system according to claim 1, wherein the handheld device is adapted to change a viewing angle with which the 3D environment is represented on the at least one display.
10. (amended) The scanning system according to claim 1, wherein the handheld device is adapted to change a magnification factor with which the 3D environment is represented on the at least one display.
11. (amended) The scanning system according to claim 1, wherein the handheld device is an intra-oral 3D scanner.
12. (amended) The scanning system according to claim 1, wherein the handheld device includes a surgical instrument.
13. (amended) The scanning system according to claim 1, wherein the handheld device includes a mechanical tool.
14. (amended) The scanning system according to claim 1, wherein the handheld device is an in-ear 3D scanner.
15. (amended) The scanning system according to claim 1, wherein the at least one display is defined as a first display, and where the system further comprises a second display.

16. (amended) The scanning system according to claim 15, wherein the second display indicates where the handheld device is positioned relative to the 3D environment.
17. (amended) The scanning system according to claim 15, wherein the first display and/or the second display provides instructions for the operator.
18. (amended) The scanning system according to claim 1, wherein audible information is provided to the operator.
19. (amended) A system comprising:  
a handheld device and at least one display;  
wherein the handheld device is adapted for switching between performing at least one action in a physical 3D environment, wherein the at least one display is adapted for visually representing the physical 3D environment; and remotely controlling the display to adjust the view with which the 3D environment is represented on the display;  
wherein the handheld device is an intra-oral 3D scanner and the at least one action performed in the physical 3D environment is scanning and that the view is remotely controlled by at least one motion sensor arranged in the handheld device, and wherein an actuator provided on the handheld device switches between performing the at least one action and remotely controlling

the view, and wherein the at least one motion sensor is a sensor that directly detects motion.

20. (new) The scanning system according to claim 1, wherein the at least one motion sensor is an accelerometer, gyro, or magnetometer.

21. (new) The scanning system according to claim 1, wherein the at least one motion sensor is adapted for taking the movement of the scanner into account while performing the scanning.

22. (new) The scanning system according to claim 1, wherein the system comprises at least two motion sensors and wherein the at least two motion sensors provide sensor fusion.

23. (new) The scanning system according to claim 1, wherein the at least one motion sensor is the 3D user interface for remotely controlling the display, wherein the view on the display is determined by moving the handheld scanner.

24. (new) The scanning system according to claim 23, wherein moving the handheld scanner to point down causes the view on the display to be a downward viewing angle.

25. (new) The scanning system according to claim 1, wherein the handheld device further comprises a user-interface element
26. (new) The scanning system according to claim 25, wherein the user-interface element comprises a touch-sensitive element, a button, a scroll-wheel, or a proximity sensor.
27. (new) The scanning system according to claim 25, wherein the user-interface element provides more than one user input.
28. (new) The scanning system according to claim 25, wherein the at least one motion sensor and/or the user-interface element are utilized in a workflow.
29. (new) The system according to claim 19, wherein the handheld device is adapted to change a magnification factor of the view represented on the at least one display which is determined by the motion of the operator's hand holding the handheld device, through the use of the at least one motion sensor.
30. (new) The scanning system according to claim 1, wherein the at least one display is arranged on a cart.
31. (new) The scanning system according to claim 1, wherein the at least one display is divided into multiple regions.

32. (new) The system according to claim 19, wherein the handheld device further comprises a user interface element,  
wherein switching to remotely controlling the view puts the handheld device into a controller mode,  
wherein holding the user interface element and/or the actuator on the handheld device in conjunction with moving the handheld device determines the view of the 3D environment on the display in accordance with signals from the motion sensor.

33. (new) A scanning system for scanning a 3D environment, the scanning system comprising:  
a handheld device including an optical scanner, wherein the 3D environment to be scanned is selected by pointing the optical scanner at the 3D environment; and  
at least one display remotely connected to the handheld device,  
wherein the handheld device is adapted for performing at least one scanning action in a physical 3D environment, and the at least one display is adapted for visually representing the physical 3D environment; and  
wherein the handheld device includes at least one motion sensor for remotely controlling the display to adjust the view with which the 3D environment is represented on the display; and  
wherein the at least one motion sensor is an accelerometer, gyro, or magnetometer.



34. (new) The scanning system according to claim 33, wherein the handheld device further comprises at least two user interface elements.
35. (new) The scanning system according to claim 34, wherein the at least two user interface elements comprises at least one button and a touch-sensitive element, and wherein the display is on a cart.
36. (new) The scanning system according to claim 35, wherein the at least one button and the touch-sensitive element provides more than one user input.
37. (new) The scanning system according to claim 36, wherein at least one of the user input provides for manually switching between performing the at least one scanning action and remotely controlling the view.
38. (new) The scanning system according to claim 37, wherein switching to remotely controlling the view puts the handheld device into a controller mode, wherein holding at least one user interface element on the handheld device in conjunction with moving the handheld device determines the view of the 3D environment on the display in accordance with signals from the motion sensor.

39. (new) The scanning system according to claim 37, wherein switching to remotely controlling the view puts the handheld device into a controller mode and wherein when in controller mode, moving the handheld device down results in showing the view of the 3D environment from a downward viewing angle on the display.

## **REMARKS**

This communication is submitted in accordance with 37 C.F.R. § 1.173.

### **Status of Claims and Support for Claim Changes**

This application for a narrowing reissue is being filed with original patent Claims 1-19, of which Claims 1-3, 5-19 are amended and Claim 4 is canceled herein, and new Claims 20-39 are added.

As of the filing of this reissue application, Claims 1-3, 5-39 are pending.

The following table lists the status of the claims as well as non-limiting, exemplary support for the claim amendments and the new claims.

Claim	Status/Support
1	Pending and Amended. Non-limiting, exemplary support found at original Claims 1 and 4; col. 1, lines 58-60; col. 6, lines 46-50; col. 9, lines 59-60; and col. 10, line 35.
2	Pending and Amended. Non-limiting, exemplary support found at original Claim 1.
3	Pending and Amended. Non-limiting, exemplary support found at original Claim 1; and col. 3, lines 28-31.
4	Canceled.
5	Pending and Amended. Non-limiting, exemplary support found at original Claim 1.
6	Pending and Amended. Non-limiting, exemplary support found at original Claims 1 and 4; col. 1, lines 58-60; and col. 5, lines 37-38 and 43-46.
7	Pending and Amended. Non-limiting, exemplary support found at original Claim 1.
8	Pending and Amended. Non-limiting, exemplary support found at original Claims 1 and 4; col. 5, lines 43-46; col. 6, lines 51-58; and col. 7, lines 14-17.
9	Pending and Amended. Non-limiting, exemplary support found at original Claim 1.
10	Pending and Amended. Non-limiting, exemplary support found at original Claim 1.
11	Pending and Amended. Non-limiting, exemplary support found at original Claim 1.
12	Pending and Amended. Non-limiting, exemplary support found at original Claim 1.

13	Pending and Amended. Non-limiting, exemplary support found at original Claim 1.
14	Pending and Amended. Non-limiting, exemplary support found at original Claim 1.
15	Pending and Amended. Non-limiting, exemplary support found at original Claim 1.
16	Pending and Amended. Non-limiting, exemplary support found at original Claim 1.
17	Pending and Amended. Non-limiting, exemplary support found at original Claim 1.
18	Pending and Amended. Non-limiting, exemplary support found at original Claim 1.
19	Pending and Amended. Non-limiting, exemplary support found at col. 6, lines 46-50; col. 9, lines 59-60; and col. 10, line 35.
20	Pending and New. Non-limiting, exemplary support found at col. 6, lines 46-50.
21	Pending and New. Non-limiting, exemplary support found at col. 3, lines 10-12.
22	Pending and New. Non-limiting, exemplary support found at col. 6, line 65-col. 7, line 3.
23	Pending and New. Non-limiting, exemplary support found at original Claim 19; col. 3, lines 15-17; and col. 4, lines 6-8.
24	Pending and New. Non-limiting, exemplary support found at Fig. 2a; col. 3, lines 18-19; and col. 11, lines 9-17.
25	Pending and New. Non-limiting, exemplary support found at col. 7, lines 4-17.
26	Pending and New. Non-limiting, exemplary support found at col. 7, lines 4-17.
27	Pending and New. Non-limiting, exemplary support found at col. 7, lines 22-34.
28	Pending and New. Non-limiting, exemplary support found at col. 7, lines 18-34.
29	Pending and New. Non-limiting, exemplary support found at original Claim 10; col. 9, lines 45-60; and col. 13, lines 28-31.
30	Pending and New. Non-limiting, exemplary support found at col. 14, lines 45-47.
31	Pending and New. Non-limiting, exemplary support found at col. 14, lines 19-21.
32	Pending and New. Non-limiting, exemplary support found at original Claim 19; col. 3, line 66-col. 4, line 8; and col. 7, lines 4-17.
33	Pending and New. Non-limiting, exemplary support found at original Claims 1, 4, 19; col. 6, lines 46-50.
34	Pending and New. Non-limiting, exemplary support found at col. 7, lines 4-34.
35	Pending and New. Non-limiting, exemplary support found at col. 7, lines 4-34; and col. 14, lines 45-47.

36	Pending and New. Non-limiting, exemplary support found at col. 7, lines 22-34.
37	Pending and New. Non-limiting, exemplary support found at original Claims 3 and 19; and col. 3, lines 28-37.
38	Pending and New. Non-limiting, exemplary support found at col. 3, lines 15-17; and col. 3, line 66-col. 4, line 8.
39	Pending and New. Non-limiting, exemplary support found at Fig. 2a; col. 3, lines 15-19; col. 3, line 66-col. 4, line 8; and col. 11, lines 9-17.

Early and favorable action concerning this application is respectfully requested.

If there are any questions concerning this Preliminary Amendment Pursuant To 37 C.F.R. § 1.173, or the reissue application in general, the Examiner is respectfully requested to telephone the undersigned attorney so that prosecution of the application may be expedited.

The Director is hereby authorized to charge any appropriate fees under 37 C.F.R. §§ 1.16, 1.17 and 1.20(d) and 1.21 that may be required by this paper, and to credit any overpayment, to Deposit Account No. 02-4800.

Favorable consideration of the application in view of the foregoing amendments is respectfully requested. Should any questions arise in connection with this application, it is respectfully requested that the undersigned be contacted at the number indicated below.

Respectfully submitted,

BUCHANAN INGERSOLL & ROONEY PC

Date July 30, 2019

By: /Stephany G. Small/  
Stephany G. Small, Ph.D.  
Registration No. 69,532

**Customer No. 21839**  
703 836 6620

## Electronic Patent Application Fee Transmittal

<b>Application Number:</b>				
<b>Filing Date:</b>				
<b>Title of Invention:</b>	SYSTEM WITH 3D USER INTERFACE INTEGRATION			
<b>First Named Inventor/Applicant Name:</b>	Henrik ÖJELUND			
<b>Filer:</b>	Stephany Gale Small/Sarah Noel			
<b>Attorney Docket Number:</b>	0079124-000266			
Filed as Large Entity				
<b>Filing Fees for Reissue (Utility)</b>				
<b>Description</b>	<b>Fee Code</b>	<b>Quantity</b>	<b>Amount</b>	<b>Sub-Total in USD(\$)</b>
<b>Basic Filing:</b>				
UTILITY REISSUE BASIC	1014	1	300	300
REISSUE OR REISSUE DESIGN CPA SEARCH FEE	1114	1	660	660
REISSUE OR REISSUE DESIGN CPA EXAM. FEE	1314	1	2200	2200
<b>Pages:</b>				
<b>Claims:</b>				
REISSUE CLAIMS IN EXCESS OF 20	1205	18	100	1800
<b>Miscellaneous-Filing:</b>				
<b>Petition:</b>				

Description	Fee Code	Quantity	Amount	Sub-Total in USD(\$)
<b>Patent-Appeals-and-Interference:</b>				
<b>Post-Allowance-and-Post-Issuance:</b>				
<b>Extension-of-Time:</b>				
<b>Miscellaneous:</b>				
<b>Total in USD (\$)</b>				<b>4960</b>

## Electronic Acknowledgement Receipt

<b>EFS ID:</b>	36730210
<b>Application Number:</b>	16526281
<b>International Application Number:</b>	
<b>Confirmation Number:</b>	9657
<b>Title of Invention:</b>	SYSTEM WITH 3D USER INTERFACE INTEGRATION
<b>First Named Inventor/Applicant Name:</b>	Henrik ÖJELUND
<b>Customer Number:</b>	21839
<b>Filer:</b>	Stephany Gale Small/Sarah Noel
<b>Filer Authorized By:</b>	Stephany Gale Small
<b>Attorney Docket Number:</b>	0079124-000266
<b>Receipt Date:</b>	30-JUL-2019
<b>Filing Date:</b>	
<b>Time Stamp:</b>	15:24:14
<b>Application Type:</b>	Reissue (Utility)

### Payment information:

Submitted with Payment	yes
Payment Type	CARD
Payment was successfully received in RAM	\$4960
RAM confirmation Number	E20197TF24585385
Deposit Account	024800
Authorized User	Sarah Noel
The Director of the USPTO is hereby authorized to charge indicated fees and credit any overpayment as follows: 37 CFR 1.16 (National application filing, search, and examination fees) 37 CFR 1.17 (Patent application and reexamination processing fees)	



37 CFR 1.19 (Document supply fees)  
 37 CFR 1.20 (Post Issuance fees)  
 37 CFR 1.21 (Miscellaneous fees and charges)

**File Listing:**

Document Number	Document Description	File Name	File Size(Bytes)/ Message Digest	Multi Part /.zip	Pages (if appl.)
1	Transmittal Reissue Application	Transmittal_NewApp.pdf	506624	no	1
			e620035e4f07dc050cdf8be7117a57cf96912b9f		
<b>Warnings:</b>					
<b>Information:</b>					
2	Application Data Sheet	ADS.pdf	1822876	no	9
			c9ab8d609240dea77ad3fba0f4af33a89c468f3b		
<b>Warnings:</b>					
<b>Information:</b>					
3	Specification	US9329675B2.pdf	5728314	no	15
			f51402e5210c9c996e4c6390181cd4024e37c7f		
<b>Warnings:</b>					
<b>Information:</b>					
4	Drawings-only black and white line drawings	Figures.pdf	2163940	no	5
			cf1663a225f3b85d464cd7da28e559d421dd0c9c		
<b>Warnings:</b>					
<b>Information:</b>					
5	Authorization for Extension of Time all replies	Authorization.pdf	93782	no	1
			946a66368c01c202c3524d200cf036b05ae26445		
<b>Warnings:</b>					
<b>Information:</b>					
6	Fee Worksheet (SB06)	Fee_Transmittal.pdf	509522	no	1
			1be4efeaed6ed09ebb8bbe46cc8ea471aa2f16c4		
<b>Warnings:</b>					
<b>Information:</b>					

7	Power of Attorney	POA.pdf	560039	no	2
			a4bb7027969bb1c77137f106ec8c258e14a090d2		
<b>Warnings:</b>					
<b>Information:</b>					
8	Assignee showing of ownership per 37 CFR 3.73	373c_Statement.pdf	1538154	no	3
			c7930b7b99f8a5d07158a4e974c8e2c1a5254e17		
<b>Warnings:</b>					
<b>Information:</b>					
9	Consent of Assignee accompanying the declaration	Consent_Assignee.pdf	505763	no	2
			003a3b7153410d149e837ea949456079bc55b170		
<b>Warnings:</b>					
<b>Information:</b>					
10	Reissue dec filed in accordance with MPEP 1414	Declaration.pdf	1278463	no	4
			db7149cddfa5548ca8d73eb538c788f98fbcde7d3		
<b>Warnings:</b>					
<b>Information:</b>					
11		Prelim.pdf	121821	yes	13
			c4be3a0f590a5624928d868f252fe0ee51a18326		
	<b>Multipart Description/PDF files in .zip description</b>				
	<b>Document Description</b>		<b>Start</b>	<b>End</b>	
	Preliminary Amendment		1	1	
	Claims		2	10	
	Applicant Arguments/Remarks Made in an Amendment		11	13	
<b>Warnings:</b>					
<b>Information:</b>					
12	Fee Worksheet (SB06)	fee-info.pdf	37132	no	2
			d81b8ddc98e2064f15bfa3c7ee0d2e01355d142		
<b>Warnings:</b>					

<b>Information:</b>	
<b>Total Files Size (in bytes):</b>	14866430
<p><b>This Acknowledgement Receipt evidences receipt on the noted date by the USPTO of the indicated documents, characterized by the applicant, and including page counts, where applicable. It serves as evidence of receipt similar to a Post Card, as described in MPEP 503.</b></p> <p><b><u>New Applications Under 35 U.S.C. 111</u></b>  <b>If a new application is being filed and the application includes the necessary components for a filing date (see 37 CFR 1.53(b)-(d) and MPEP 506), a Filing Receipt (37 CFR 1.54) will be issued in due course and the date shown on this Acknowledgement Receipt will establish the filing date of the application.</b></p> <p><b><u>National Stage of an International Application under 35 U.S.C. 371</u></b>  <b>If a timely submission to enter the national stage of an international application is compliant with the conditions of 35 U.S.C. 371 and other applicable requirements a Form PCT/DO/EO/903 indicating acceptance of the application as a national stage submission under 35 U.S.C. 371 will be issued in addition to the Filing Receipt, in due course.</b></p> <p><b><u>New International Application Filed with the USPTO as a Receiving Office</u></b>  <b>If a new international application is being filed and the international application includes the necessary components for an international filing date (see PCT Article 11 and MPEP 1810), a Notification of the International Application Number and of the International Filing Date (Form PCT/RO/105) will be issued in due course, subject to prescriptions concerning national security, and the date shown on this Acknowledgement Receipt will establish the international filing date of the application.</b></p>	



US009329675B2

(12) **United States Patent**  
**Öjelund et al.**

(10) **Patent No.:** **US 9,329,675 B2**  
(45) **Date of Patent:** **May 3, 2016**

(54) **SYSTEM WITH 3D USER INTERFACE INTEGRATION**

(75) Inventors: **Henrik Öjelund**, Lyngby (DK); **David Fischer**, Stenløse (DK); **Karl-Josef Hollenbeck**, København Ø (DK)

(75) Assignee: **3SHAPE A/S**, Copenhagen K (DK)

(\*) Notice: Subject to any disclaimer, the term of this patent is extended or adjusted under 35 U.S.C. 154(b) by 249 days.

(21) Appl. No.: **13/991,513**

(22) PCT Filed: **Dec. 5, 2011**

(86) PCT No.: **PCT/DK2011/050461**

§ 371 (c)(1),  
(2), (4) Date: **Jun. 4, 2013**

(87) PCT Pub. No.: **WO2012/076013**

PCT Pub. Date: **Jun. 14, 2012**

(65) **Prior Publication Data**

US 2013/0257718 A1 Oct. 3, 2013

**Related U.S. Application Data**

(60) Provisional application No. 61/420,138, filed on Dec. 6, 2010.

(30) **Foreign Application Priority Data**

Dec. 6, 2010 (DK) ..... 2010 01104

(51) **Int. Cl.**  
**G06F 3/01** (2006.01)  
**A61C 9/00** (2006.01)  
**G01B 11/24** (2006.01)

(52) **U.S. Cl.**  
CPC . **G06F 3/01** (2013.01); **A61C 9/004** (2013.01); **G01B 11/24** (2013.01)

(58) **Field of Classification Search**  
CPC combination set(s) only.  
See application file for complete search history.

(56) **References Cited**

**U.S. PATENT DOCUMENTS**

6,135,961 A	10/2000	Pflugrath et al.	
6,967,644 B1 *	11/2005	Kobayashi	345/158
7,141,020 B2	11/2006	Poland et al.	
7,813,591 B2 *	10/2010	Paley et al.	382/285
7,831,292 B2 *	11/2010	Quaid et al.	660/424
8,035,637 B2 *	10/2011	Kriveshko	345/419

(Continued)

**FOREIGN PATENT DOCUMENTS**

CN	101513350	8/2009
WO	WO 2004/066615 A1	8/2004

(Continued)

**OTHER PUBLICATIONS**

Three-Dimensional Virtual Reality Xia et al. Jun. 2001.\*

(Continued)

*Primary Examiner* --- Van Chow

(74) *Attorney, Agent, or Firm* --- Buchanan Ingersoll & Rooney PC

(57) **ABSTRACT**

Disclosed is a system comprising a handheld device and at least one display. The handheld device is adapted for performing at least one action in a physical 3D environment; wherein the at least one display is adapted for visually representing the physical 3D environment; and where the handheld device is adapted for remotely controlling the view with which the 3D environment is represented on the display.

**19 Claims, 5 Drawing Sheets**

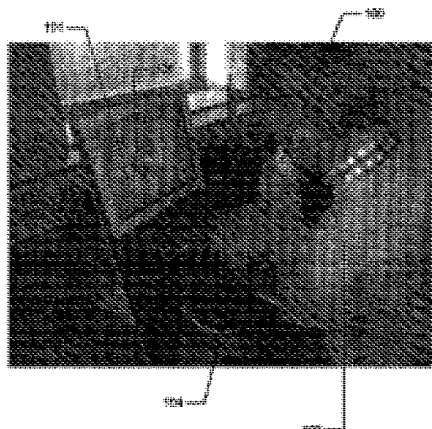

(56)

References Cited

U.S. PATENT DOCUMENTS

8,384,665	B1 *	2/2013	Powers et al.	345/156
2003/0158482	A1	8/2003	Poland et al.	
2004/0204787	A1 *	10/2004	Kepelman et al.	700/182
2005/0057745	A1	3/2005	Bontje	
2006/0025684	A1	2/2006	Quistgaard et al.	
2006/0092133	A1 *	5/2006	Touma et al.	345/158
2006/0146009	A1	7/2006	Syrbe et al.	
2009/0061381	A1	3/2009	Durbin et al.	
2009/0217207	A1	8/2009	Kagenmeier et al.	

FOREIGN PATENT DOCUMENTS

WO	2007084727	7/2007
WO	2009089126	7/2009
WO	2001011193	1/2011

OTHER PUBLICATIONS

International Search Report (PCT/ISA/210) issued on Feb. 22, 2012, by the Danish Patent Office as the International Searching Authority for International Application No. PCT/DK/2011/050461.  
 C. Graetzel et al., "A Non-Contact Mouse for Surgeon-Computer Interaction", *Technology and Health Care*, 12(3), 2004, pp. 1-19.  
 Sebastian Vogt et al., "An AR System With Intuitive User Interface for Manipulation and Visualization of 3D Medical Data", *Stud. Health Technol. Inform., Medicine Meets Virtual Reality 12*, 2004, vol. 98, pp. 397-403.  
 First Office Action issued in corresponding Chinese Patent Application No. 201180066956.6, issued Apr. 3, 2015. (13 pages).  
 Second Office Action issued in corresponding Chinese Patent Application No. 201180066956.6, dated Nov. 18, 2015, with English translation (27 pages).

\* cited by examiner

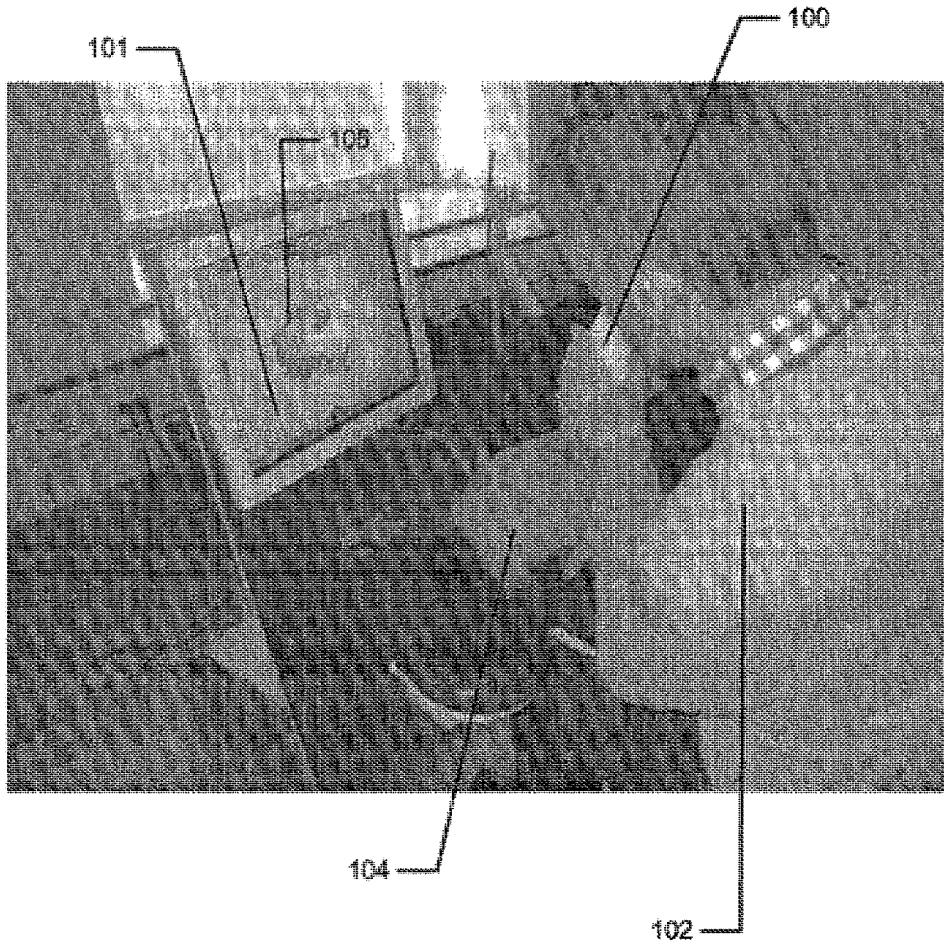

Fig. 1

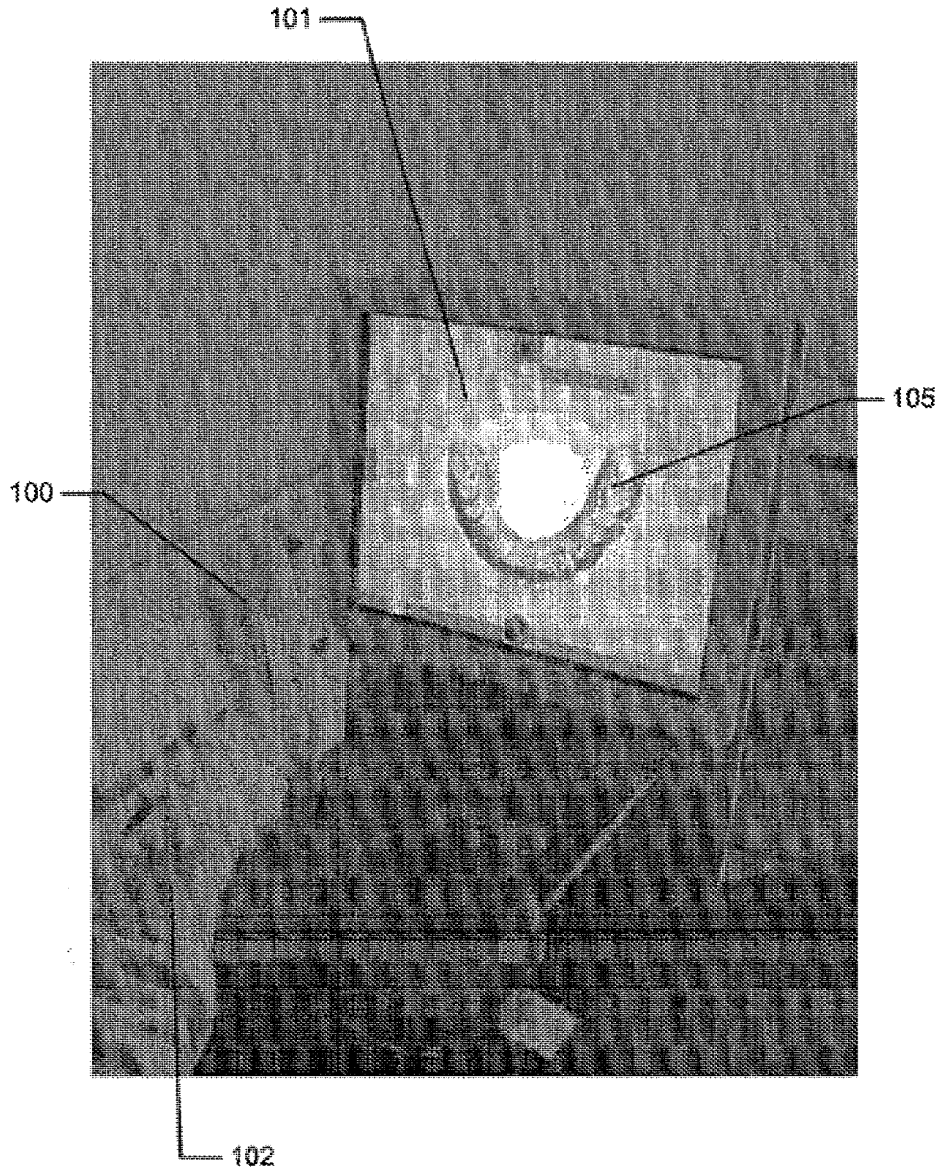

Fig. 2a)

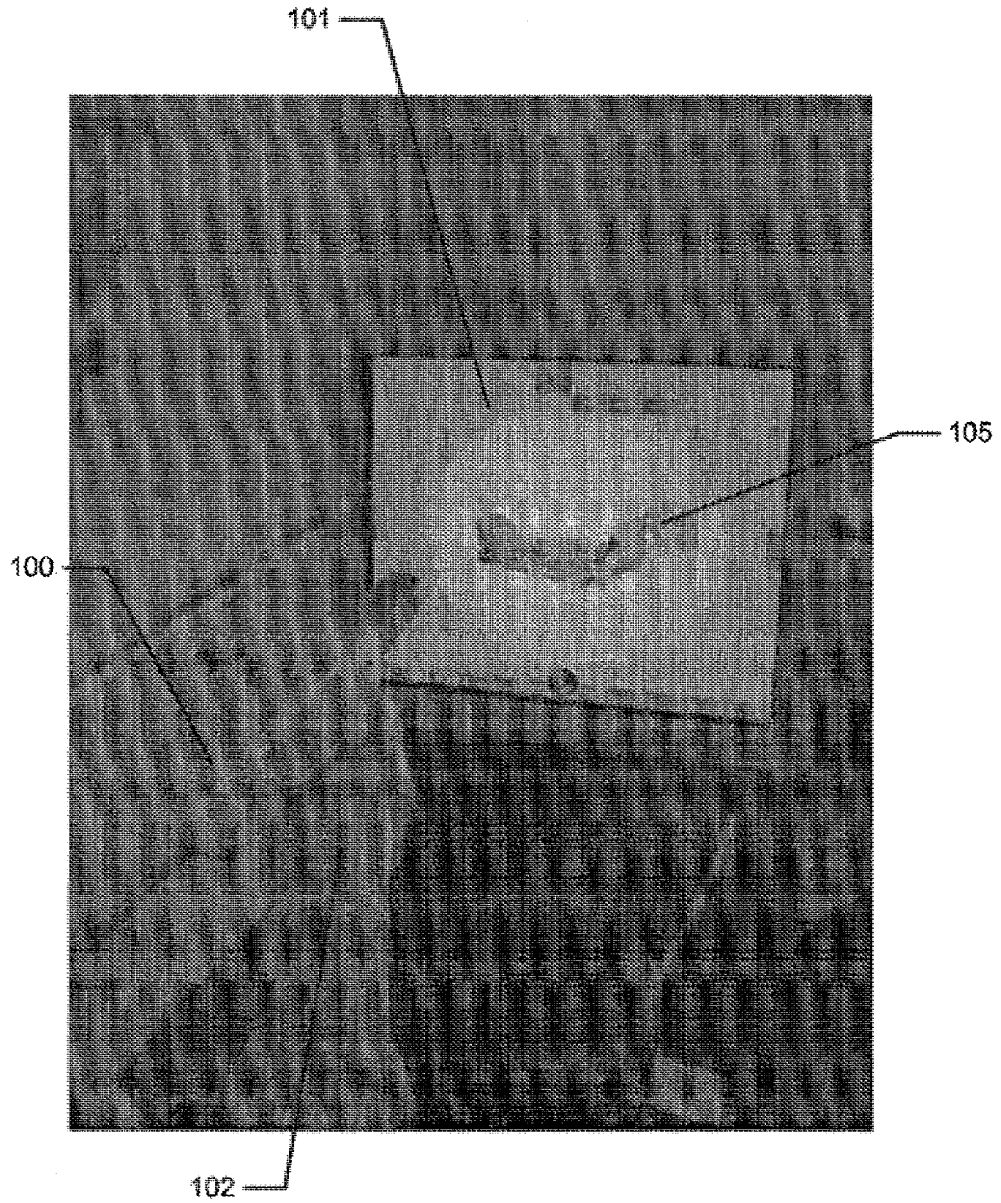

Fig. 2b)



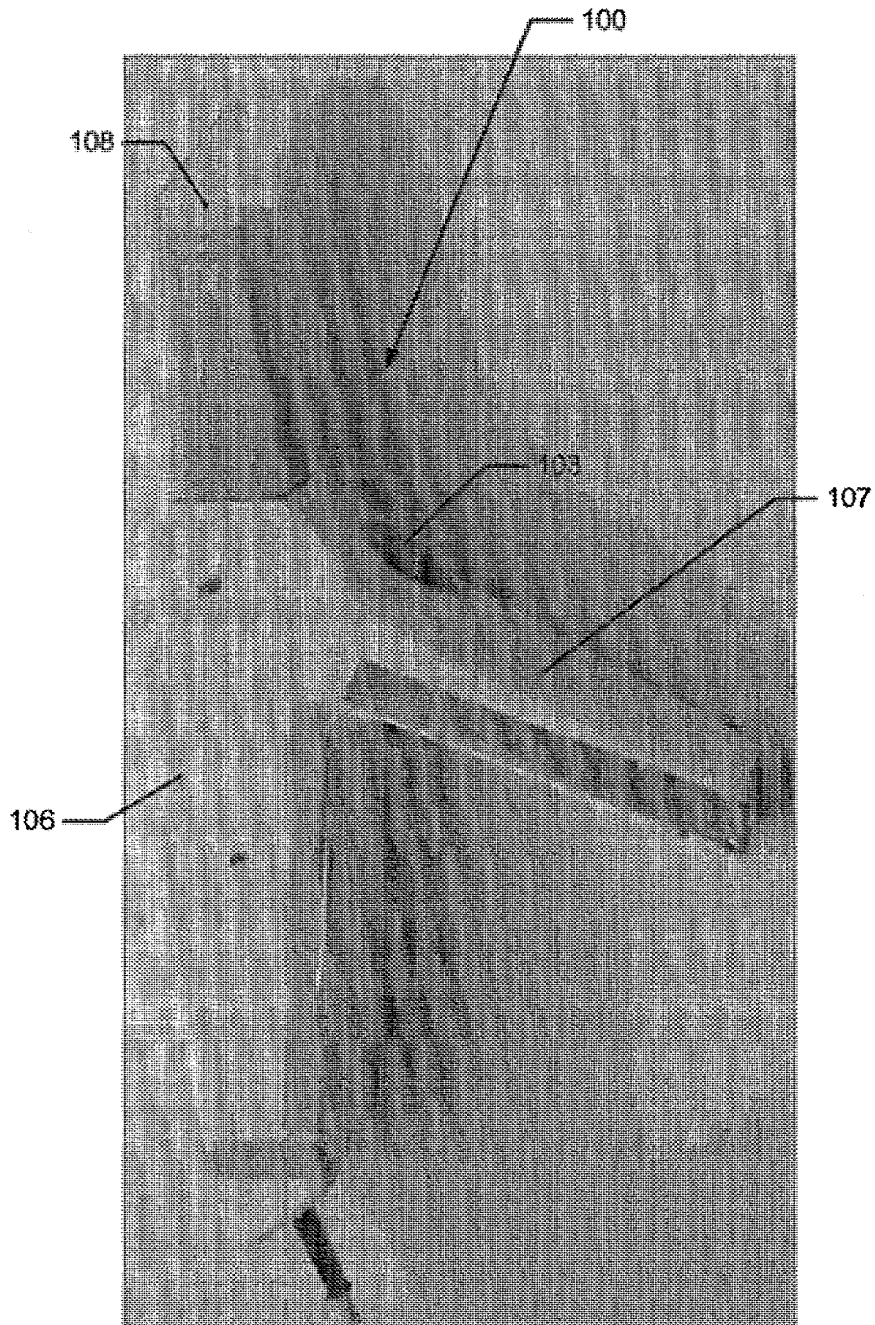

Fig. 3

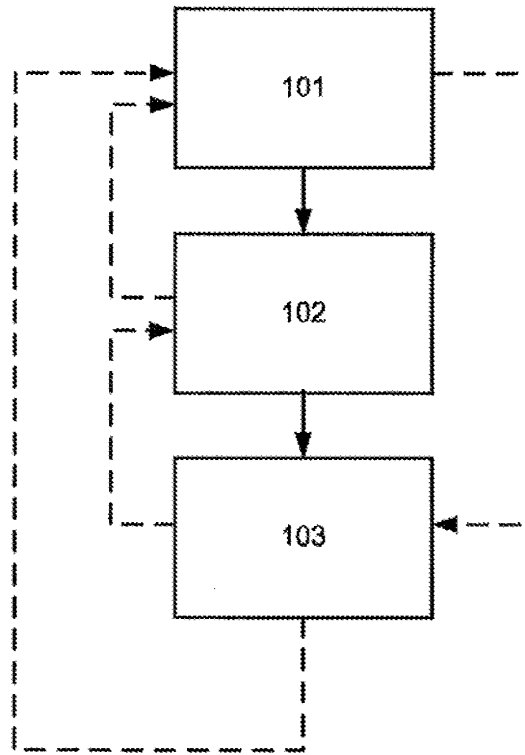

Fig. 4

1

## SYSTEM WITH 3D USER INTERFACE INTEGRATION

### FIELD OF THE INVENTION

This invention generally relates to a method and a system comprising a handheld device and at least one display.

### BACKGROUND OF THE INVENTION

3D visualization is important in many fields of industry and medicine, where 3D information is becoming more and more predominant.

Displaying and inspecting 3D information is inherently difficult. To fully understand a 3D object or entire environment on a screen, the user should generally be able to rotate the object or scene, such that many or preferentially all surfaces are displayed. This is true even for 3D displays, e.g. stereoscopic or holographic, where from a given viewing position and with a given viewing angle, the user will only see some surfaces of an arbitrary 3D environment. Often, the user will also want to zoom into details or zoom out for an overview.

Various user interaction devices are in use for software that displays 3D data; these devices are: 3D mice, space balls, and touch screens. The operation of these current interaction devices requires physically touching them.

Physically touching a user-interaction device can be a disadvantage in medical applications due to risks of cross-contamination between patients or between patient and operator, or in industrial applications in dirty environments.

Several non-touch user interfaces for 3D data viewing in medical applications have been described in the literature. Vogt et al (2004) describe a touchless interactive system for in-situ visualization of 3D medical imaging data. The user interface is based on tracking of reflective markers, where a camera is mounted on the physician's head. Graetzel et al (2004) describe a touchless system that interprets hand gestures as mouse actions. It is based on stereo vision and intended for use in minimally invasive surgery.

It remains a problem to improve systems that require user interfaces for view control, which for example can be used for clinical purposes.

### SUMMARY

Disclosed is a system comprising a handheld device and at least one display, where the handheld device is adapted for performing at least one action in a physical 3D environment, where the at least one display is adapted for visually representing the physical 3D environment, and where the handheld device is adapted for remotely controlling the view with which said 3D environment is represented on the display.

The system may be adapted for switching between performing the at least one action in the physical 3D environment, and remotely controlling the view with which the 3D environment is represented on the display.

The system disclosed here performs the integration of 3D user interface functionality with any other handheld device with other operating functionality, such that the operator ideally only touches this latter device that is intended to be touched. A particular example of such a handheld device is one that records some 3D geometry, for example a handheld 3D scanner.

The handheld device is a multi-purpose device, such as a dual-purpose or two-purpose device, i.e. a device both for performing actions in the physical 3D environment, such as

2

measuring and manipulating, and for remotely controlling the view of the 3D environment on the display.

Geometrically, a view is determined by the virtual observer's/camera's position and orientation relative to the 3D environment or its visual representation. If the display is two-dimensional, the view is also determined by the type of projection. A view may also be determined by a magnification factor.

The virtual observer's and the 3D environment's position and orientation are always relative to each other. In terms of user experience in software systems with 3D input devices, the user may feel that for example, he/she is moving the 3D environment while remaining stationary himself/herself, but there is always an equivalent movement of the virtual observer/camera that gives the same results on the display. Often, descriptions of 3D software systems use the expression "pan" to indicate an apparent translational movement of the 3D environment, "rotate" to indicate a rotational movement of the 3D environment, and "zoom" to indicate a change in magnification factor.

Graphically, a view can represent a 3D environment by means of photographs or as some kind of virtual representation such as a computer graphic, or similar. A computer graphic can be rendered for example with texture and/or shading and/or virtual light sources and/or light models for surface properties. A computer graphic can also be a simplified representation of the 3D environment, for example a mesh, an outline, or an otherwise simplified representation. All or parts of the 3D environment can also be rendered with some degree of transparency. A view may represent the 3D environment in total or only parts thereof.

All of the touch-less prior art systems are 3D user interface devices only. In many prior art applications, the operator using such user interface device will also hold and work with another device that really is the central device in the overall application, e.g. a medical instrument.

It is thus an advantage of the present system that the 3D user-interface functionality is integrated in the central device, which is used for performing some kind of action.

In some embodiments the handheld device is adapted for remotely controlling the magnification with which the 3D environment is represented on the display.

In some embodiments the handheld device is adapted for changing the rendering of the 3D environment on the display. In some embodiments the view is defined as viewing angle and/or viewing position.

In some embodiments the at least one action comprises one or more of the actions of:

- measuring,
- recording,
- scanning,
- manipulating,
- modifying.

In some embodiments the 3D environment comprises one or more 3D objects.

In some embodiments the handheld device is adapted to be held in one hand by an operator.

In some embodiments the display is adapted to represent the 3D environment from multiple views.

In some embodiments the display is adapted to represent the 3D environment from different viewing angles and/or viewing positions.

In some embodiments the view of the 3D environment in the at least one display is at least partly determined by the motion of the operator's hand holding said device.

3

In some embodiments the magnification represented in the at least one display is at least partly determined by the motion of the operator's hand holding said device.

In some embodiments the handheld device is adapted to record the 3D geometry of the 3D environment.

Thus the handheld device may be an intraoral dental scanner, which records the 3D geometry of a patient's teeth. The operator may move the scanner along the teeth of the patient for capturing the 3D geometry of the relevant teeth, e.g. all teeth. The scanner may comprise motion sensors for taking the movement of the scanner into account while creating the 3D model of the scanned teeth.

The 3D model of the teeth may be shown on a display, and the display may for example be a PC screen and/or the like.

The user interface functionality may comprise incorporating motion sensors in the scanner to provide that the user can determine the view on the screen by moving the scanner. Pointing the scanner down can provide that the scanned teeth are shown given a downward viewing angle. Holding the scanner in a horizontal position can provide that the viewing angle is likewise horizontal.

In some embodiments the handheld device comprises at least one user-interface element. A user-interface element is an element which the user may manipulate in order to activate a function on the user interface of the software. Typically the use interface is graphically presented on the display of the system.

The handheld device may furthermore be provided with an actuator, which switches the handheld device between performing the at least one action and remotely controlling the view. By providing such a manual switching function that enables the operator to switch between performing the at least one action and remotely controlling the view, the operator may easily control what is performed.

Such an actuator can for example be in the form of a button, switch or contact. In other embodiments it could be a touch sensitive surface or element.

In another embodiment the actuator could be a motion sensor provided in the handheld device that function as the actuator when it registers a specific type of movement, for example if the operator shakes the handheld device. Examples of such motion sensors will be described herein with respect to the user-interface element, however, the person skilled in the art will based on the disclosure herein understand that such motion sensors may also be used as actuators as discussed.

For example, the handheld device can in one embodiment be an intra-oral 3D scanner used by a dentist. The scanner is set to be performing the action of scanning a dental area when the actuator is in one position. When the actuator is switched into a second position the handheld is set to control the view with which the 3D environment is represented on the display. This could for example be that when the dentist have scanned a part of or the complete desired area of an dental arch he can activate the actuator which then allows the dentist to remotely control the view of the 3D representation of the scanned area on the display by using the handheld device.

For example, the actuator could be a button. When the button is pressed quickly the handheld device is prepared for scanning, i.e. it is set for performing at least one action, the scanning procedure, in the physical 3D environment. The scanning is stopped when the button is pressed quickly a second time.

While the scanning is performed a virtual 3D representation is visually built on the display.

The user can now press and hold the button. This will put the handheld in a controller mode, where the handheld device

4

is adapted for remotely controlling the view with which the 3D environment, such as scanned teeth, is represented on the display. While holding the button pressed the system will use signals from a motion sensor in the handheld device to determine how to present the view of the virtual 3D environment. Thus, if the user turns or otherwise moves the hand that holds the handheld device the view of the virtual 3D environment on the display will change accordingly.

Thus, the dentist may use the same handheld device for both scanning an area and subsequently verifying that the scan has been executed correctly without having to move away from the patient or touching any other equipment than already present in his hands.

In one embodiment the user-interface element is the same as the actuator, or where several user-interface elements are present at least one also functions as an actuator.

The system may be equipped with a button as an additional element providing the user-interface functionality.

In an example the handheld device is a handheld intraoral scanner, and the display is a computer screen. The operator or user may be a dentist, an assistant and/or the like. The operation functionality of the device may be to record some intraoral 3D geometry, and the user interface functionality may be to rotate, pan, and zoom the scanned data on the computer screen.

In some embodiments the at least one user-interface element is at least one motion sensor.

Thus the integration of the user interface functionality in the device may be provided by motion sensors, which can be accelerometers inside the scanner, whose readings determine the orientation of the display on the screen of the 3D model of the teeth acquired by the scanner. Additional functionality, e.g. to start/stop scanning, may be provided by a button. The button may be located where the operator's or user's index finger can reach it conveniently.

Prior art intraoral scanners use a touch screen, a trackball, or a mouse to determine the view in the display. These prior art user interface devices can be inconvenient, awkward and difficult to use, and they can be labor-intensive, and thus costly to sterilize or disinfect. An intraoral scanner should always be disinfected between scanning different patients, because the scanner is in and may come in contact with the mouth or other parts of the patient being scanned.

The operator or user, e.g. dentist, may use one hand or both hands to hold the intraoral scanner while scanning, and the scanner may be light enough and comfortable to be held with just one hand for a longer time while scanning.

The device can also be held with one or two hands, while using the device as remote control for e.g. changing the view in the display. It is an advantage of the touchless user interface functionality that in clinical situations, the operator can maintain both hands clean, disinfected, or even sterile.

An advantage of the system is that it allows an iterative process of working in a 3D environment without releasing the handheld device during said process. For the above intraoral scanning system example, the operator, e.g. dentist, can record some teeth surface geometry with a handheld device that is an intraoral scanner, inspect coverage of the surface recording by using that same handheld device to move, e.g. rotate, the recorded surface on the display, e.g. a computer screen, detect possible gaps or holes in the coverage of the scanned teeth, and then for example arrange the scanner in the region where the gaps were located and continue recording teeth surface geometry there. Over this entire iterative cycle, which can be repeated more than once, such as as many times

as required for obtaining a desired scan coverage of the teeth, the dentist does not have to lay the handheld intraoral scanner out of his or her hands.

In some embodiments, the 3D user interface functionality is exploited in a separate location than the operation functionality. For the above intraoral scanning system example, the scanning operation is performed in the oral cavity of the patient, while the user interface functionality is more flexibly exploited when the scanner is outside the patient's mouth. The key characteristic and advantage of the system, again, is that the dentist can exploit the dual and integrated functionality, that is operation and user interface, of the scanner without laying it out of his or her hands.

The above intraoral scanning system is an example of an embodiment. Other examples for operation functionality or performing actions could be drilling, welding, grinding, cutting, soldering, photographing, filming, measuring, executing some surgical procedure etc.

The display of the system can be a 2D computer screen, a 3D display that projects stereoscopic image pairs, a volumetric display creating a 3D effect, such as a swept-volume display, a static volume display, a parallax barrier display, a holographic display etc. Even with a 3D display, the operator has only one viewing position and viewing angle relative to the 3D environment at a time. The operator can move his/her head to assume another viewing position and/or viewing angle physically, but generally, it may be more convenient to use the handheld device with its built-in user interface functionality, e.g. the remote controlling, to change the viewing position and/or viewing angle represented in the display.

In some embodiments the system comprises multiple displays, or one or more displays that are divided into regions. For example, several sub-windows on a PC screen can represent different views of the 3D environment. The handheld device can be used to change the view in all of them, or only some of them.

In some embodiments the user interface functionality comprises the use of gestures.

Gestures made by e.g. the operator can be used to change, shift or toggle between sub-windows, and the user-interface functionality can be limited to an active sub-window or one of several displays.

In some embodiments the gestures are adapted to be detected by the at least one motion sensor. Gestures can alternatively and/or additionally be detected by range sensors or other sensors that record body motion.

The operator does not have to constantly watch the at least one display of the system. In many applications, the operator will shift between viewing and possible manipulating the display and performing another operation with the handheld device. Thus it is an advantage that the operator does not have to touch other user interface devices. However, in some cases it may not be possible for the operator to fully avoid touching other devices, and in these cases it is an advantage that fewer touches are required compared to a system where a handheld device does not provide any user interface functionality at all.

In some embodiments the at least one display is arranged separate from the handheld device.

In some embodiments the at least one display is defined as a first display, and where the system further comprises a second display.

In some embodiments the second display is arranged on the handheld device.

In some embodiments the second display is arranged on the handheld device in a position such that the display is adapted to be viewed by the operator, while the operator is operating the handheld device.

In some embodiments the second display indicates where the handheld device is positioned relative to the 3D environment.

In some embodiments the first display and/or the second display provides instructions for the operator.

The display(s) can be arranged in multiple ways. For example, they can be mounted on a wall, placed on some sort of stand or a cart, placed on a rack or desk, or other.

In some embodiments at least one display is mounted on the device itself. It can be advantageous to have a display on the device itself because with such an arrangement, the operator's eyes need not focus alternately between different distances. In some cases, the operating functionality may require a close look at the device and the vicinity of the 3D environment it operates in, and this may be at a distance at most as far away as the operator's hand. Especially in crowded environments such as dentist's clinics, surgical operation theatres, or industrial workplaces, it may be difficult to place an external display closely to the device.

In some embodiments visual information is provided to the operator on one or more means other than the first display.

In some embodiments audible information to the operator is provided to the operator.

Thus in some embodiments, the system provides additional information to the operator. In some embodiments, the system includes other visual clues shown on means other than the display(s), such as LEDs on the device. In some embodiments, the system provides audible information to the operator, for example by different sounds and/or by speech.

Said information provided to the operator can comprise instructions for use, warnings, and the like.

The information can aid with improving the action performance or operation functionality of the device, for example by indicating how well an action or operation is being performed, and/or instructions to the operator aimed at improving the ease of the action or operation and/or the quality of the action or operation's results. For example, a LED can change in color and/or flashing frequency. In a scanner, the information can relate to how well the scanned 3D environment is in focus and/or to scan quality and/or to scan coverage. The information can comprise instructions on how best to position the scanner such as to attain good scan quality and/or scan coverage. The instructions can be used for planning and/or performing bracket placement. The instructions can be in the form of a messenger system to the operator.

In some embodiments, some 3D user interface functionality is provided by at least one motion sensor built into the device. Examples of motion sensors are accelerometers, gyros, and magnetometers and/or the like. These sensors can sense rotations, lateral motion, and/or combinations thereof. Other motion sensors use infrared sensing. For example, at least one infrared sensor can be mounted on the device and at least one infrared emitter can be mounted in the surroundings of the device. Conversely, the at least one emitter can be mounted on the device, and the at least one sensors in the surroundings. Yet another possibility is to use infrared reflector(s) on the device and both sensor(s) and emitter(s) on the surroundings, or again conversely. Thus motion can be sensed by a variety of principles.

Through proper signal processing, some sensors can recognize additional operator actions; for example gestures such as taps, waving, or shaking of the handheld device. Thus, these gestures can also be exploited in the 3D user interface functionality.

In some embodiments the handheld device comprises at least two motion sensors providing sensor fusion. Sensor fusion can be used to achieve a better motion signal from for

example raw gyro, accelerometer, and/or magnetometer data. Sensor fusion can be implemented in ICs such as the InvenSense MPU 3000.

In some embodiments the handheld device comprises at least one user-interface element other than the at least one motion sensor.

In some embodiments the at least one other user-interface element is a touch-sensitive element.

In some embodiments the at least one other user-interface element is a button.

In some embodiments the at least one other user-interface element is a scroll-wheel.

In some embodiments, user interface functionality is provided through additional elements on the device. Thus these additional elements can for example be buttons, scroll wheels, touch-sensitive fields, proximity sensors and/or the like.

The additional user interface elements can be exploited or utilized in a workflow suitable for the field of application of the device. The workflow may be implemented in some user software application that may also control the display and thus the view represented thereon. A given interface element can supply multiple user inputs to the software. For example, a button can provide both a single click and a double click. For example, a double click can mean to advance to a subsequent step in a workflow. For the example of intraoral scanning, three steps within the workflow can be to scan the lower mouth, the upper mouth, and the bite. A touch-sensitive field can provide strokes in multiple directions each with a different effect, etc. Providing multiple user inputs from a user interface elements is advantageous because the number of user interface elements on the device can be reduced relative to a situation where each user interface element only provides one user input.

The motion sensors can also be exploited in a workflow. For example, lifting the device, which can be sensed by an accelerometer, can represent some type of user input, for example to start some action. In a device that is a scanner, it may start scanning. Conversely, placing the device back in some sort of holder, which can be sensed by an accelerometer as no acceleration occur over some period of time, can stop said action.

If the action performed by the device is some kind of recording, for example scanning, for example 3D scanning, the results of the recording can also be exploited as user inputs, possibly along with user inputs from other user interface elements. For example, with a 3D scanner with a limited depth of field, it may be possible to detect whether any objects within the 3D environments are present in the volume corresponding to this depth of field by detecting whether any 3D points are recorded. User inputs can depend on such detected presence. For example, a button click on an intraoral scanner can provide a different user input depending on whether the scanner is in the mouth, where teeth are detectable, or significantly away from and outside the mouth. Also the effect of motion sensor signals can be interpreted differently for either situation. For example, the scanner may only change the view represented on the display when it is outside the mouth.

In some embodiments the handheld device is adapted to change a viewing angle with which the 3D environment is represented on the at least one display.

In some embodiments the handheld device is adapted to change a magnification factor with which the 3D environment is represented on the at least one display.

In some embodiments the handheld device is adapted to change a viewing position with which the 3D environment is represented on the at least one display.

In some embodiments the view of the 3D environment comprises a viewing angle, a magnification factor, and/or a viewing position.

In some embodiments the view of the 3D environment comprises rendering of texture and/or shading.

In some embodiments the at least one display is divided into multiple regions, each showing the 3D environment with a different view.

Thus in some embodiments the user interface functionality comprises changing the view with which the 3D environment is displayed. Changes in view can comprise changes in viewing angle, viewing position, magnification and/or the like. A change in viewing angle can naturally be effected by rotating the device. Rotation is naturally sensed by the aid of gyros and/or relative to gravity sensed by an accelerometer. Zooming, i.e. a change in magnification, can for example be achieved by pushing the handheld device forward and backward, respectively. A translational change of the viewing position, i.e., panning, can for example be achieved by pushing the handheld device up/down and/or sideways.

In some embodiments the user interface functionality comprises selecting or choosing items on a display or any other functionality provided by graphical user interfaces in computers known in the art. The operator may perform the selection. The Lava C.O.S scanner marketed by 3M ESPE has additional buttons on the handheld device, but it is not possible to manipulate the view by these. Their only purpose is to allow navigation through a menu system, and to start/stop scanning.

In some embodiments the user interface functionality comprises manipulating the 3D environment displayed on the screen. For example, the operator may effect deformations or change the position or orientation of objects in the 3D environment. Thus, in some embodiments the user interface functionality comprises virtual user interface functionality, which can be that the 3D data are manipulated, but the physical 3D environment in which the device operates may not be manipulated.

In some embodiments the handheld device is an intraoral scanner and/or an in-the-ear scanner. If the scanner comprises a tip, this tip may be exchanged whereby the scanner can become suitable for scanning in the mouth or in the ear. Since the ear is a smaller cavity than the mouth, the tip for fitting into an ear may be smaller than a tip for fitting in the mouth.

In some embodiments the handheld device is a surgical instrument. In some embodiments, the surgical instrument comprises at least one motion sensor, which is built-in in the instrument.

In some embodiments the handheld device is a mechanical tool. In some embodiments, the tool has at least one motion sensor built in. In other embodiments, other user-interface elements are built in as well, for example buttons, scroll wheels, touch-sensitive fields, or proximity sensors.

In some embodiment the 3D geometry of the 3D environment is known a-priori or a 3D representation of the environment is known a priori, i.e. before the action(s) are performed. For example in surgery, a CT scan may have been taken before the surgical procedure. The handheld device in this example could be a surgical instrument that a physician needs to apply in the proper 3D position. To make sure this proper position is reached, it could be beneficial to view the 3D environment from multiple perspectives interactively, i.e. without having to release the surgical instrument.

An advantage of the system, also in the above surgery example, is the ability of the handheld device to record the 3D environment at least partially, typically in a 3D field-of-view that is smaller than the volume represented in the a-priori

data. The 3D data recorded by the handheld device can be registered in real time with the a-priori data, such that the position and orientation of the device can be detected.

In some embodiments the 3D geometry comprises a 3D surface of the environment.

In some embodiments the 3D geometry comprises a 3D volumetric representation of the environment.

Thus the 3D environment can be displayed as volumetric data, or as surface, or a combination thereof. Volumetric data are typically represented by voxels. Voxels can comprise multiple scalar values. Surface data are typically represented as meshed, such as triangulated meshes, or point clouds.

The scanning may be performed by means of LED scanning, laser light scanning, white light scanning, X-ray scanning, and/or CT scanning.

The present invention relates to different aspects including the system described above and in the following, and corresponding systems, methods, devices, uses, and/or product means, each yielding one or more of the benefits and advantages described in connection with the first mentioned aspect, and each having one or more embodiments corresponding to the embodiments described in connection with the first mentioned aspect and/or disclosed in the appended claims.

In particular, disclosed herein is a method of interaction between a handheld device and at least one display, where the method comprises the steps of:

- performing at least one action in a physical 3D environment by means of the handheld device;
- visually representing the physical 3D environment by the at least one display; and
- remotely controlling the view of the represented 3D environment on the display by means of the handheld device.

Furthermore, the invention relates to a computer program product comprising program code means for causing a data processing system to perform the method according to any of the embodiments, when said program code means are executed on the data processing system, and a computer program product, comprising a computer-readable medium having stored there on the program code means.

According to another aspect, disclosed is a system comprising a handheld device for operating in a 3D environment and at least one display for visualizing said environment, where the display is adapted to represent said environment from multiple perspectives, where said device is adapted to be held in one hand by an operator, and where the perspective represented in the at least one display is at least partly determined by the motion of the operator's hand holding said device.

According to another aspect, disclosed is a system comprising a handheld device for operating in a 3D environment and at least one display for visualizing said environment, where the display is adapted to represent said environment in multiple views, where said device is adapted to be held in one hand by an operator, where the view represented in the at least one display is at least partly determined by the motion of the operator's hand holding said device, and where the device has at least one touch-sensitive user interface element.

The motion of the operator's hand is typically determined by a motion sensor arranged in the handheld device.

#### DEFINITIONS

**3D geometry:** A constellation of matter or its virtual representation in a three-dimensional space.

**3D environment:** A constellation of physical objects each having a 3D geometry in a three-dimensional space.

**View:** The way a 3D environment is represented on a display. Geometrically, a view is determined by the virtual observer's/camera's position and orientation. If the display is two-dimensional, the view is also determined by the type of projection. A view may also be determined by a magnification factor. Graphically, a view can show the 3D environment by means of photographs or as some kind of virtual representation such as a computer graphic, or similar. A computer graphic can be rendered for example with texture and/or shading and/or virtual light sources and/or light models for surface properties. A computer graphic can also be a simplified representation of the 3D environment, for example a mesh, an outline, or an otherwise simplified representation. All or parts of the 3D environment can also be rendered with some degree of transparency. A view may represent the 3D environment in total or only parts thereof.

**Functionality: A Purpose or Intended Use.**

**Performing action(s) or operating functionality:** Actions or functionality that includes some type of interaction with a 3D environment, such as measuring, modifying, manipulating, recording, touching, sensing, scanning, moving, transforming, cutting, welding, chemically treating, cleaning, etc. The term "operating" is thus not directed to surgical procedures, but operating may comprise surgical procedures.

**User interface Functionality:** Functionality for interaction between a human user and a machine with a display.

**Handheld device:** An object that has at least one functionality and that is held by a human operator's hand or both hands while performing this at least one functionality.

**3D scanner:** A device that analyzes a real-world object or 3D environment to collect data on its shape and possibly its appearance.

**Coverage of scan:** The degree to which a physical surface is represented by recorded data after a scanning operation.

**Motion sensor:** A sensor detecting motion. Motion can be detected by: sound (acoustic sensors), opacity (optical and infrared sensors and video image processors), geomagnetism (magnetic sensors, magnetometers), reflection of transmitted energy (infrared laser radar, ultrasonic sensors, and microwave radar sensors), electromagnetic induction (inductive-loop detectors), and vibration (triboelectric, seismic, and inertia-switch sensors). MEMS accelerometers, gyros, and magnetometers are examples of motions sensors.

**Workflow:** a sequence of tasks implemented in software.

#### BRIEF DESCRIPTION OF THE DRAWINGS

The above and/or additional objects, features and advantages of the present invention, will be further elucidated by the following illustrative and non-limiting detailed description of embodiments of the present invention, with reference to the appended drawings, wherein:

FIG. 1 shows an example of the system comprising a handheld device and a display.

FIG. 2 shows an example of user interface functionality in the form of remote controlling using the handheld device.

FIG. 3 shows an example of the handheld device.

FIG. 4 shows an example of a flow-chart of a method of interaction between a handheld device and a display.

#### DETAILED DESCRIPTION

In the following description, reference is made to the accompanying figures, which show by way of illustration how the invention may be practiced.

FIG. 1 shows an example of the system comprising a handheld device and a display. The handheld device 100 is in this

11

example an intraoral dental scanner, which records the 3D geometry of the patient's teeth. The operator 102 moves the scanner along the teeth of the patient 104 for capturing the 3D geometry of the relevant teeth, e.g. all teeth. The scanner comprises motion sensors (not visible) for taken the movement of the scanner into account while creating the 3D model 105 of the scanned teeth. The display 101 is in this example a PC screen displaying the data recorded by the scanner.

FIG. 2 shows an example of user interface functionality in the form of remote controlling using the handheld device. The motion sensors (not shown) in the handheld device 100, e.g. scanner, provide that the user 102 can determine the view shown on the display 101, e.g. screen, by moving the handheld device 100.

FIG. 2a) shows that pointing the device 100 down can provide that the 3D model 105 of the scanned teeth is shown from a downward viewing angle.

FIG. 2b) shows that holding the scanner in a horizontal position can provide that the viewing angle is likewise horizontally from the front, such that the 3D model 105 of the scanned teeth is shown from the front.

FIG. 3 shows an example of the handheld device.

The handheld device 100 is in this example an intraoral scanner with a pistol-grip. The scanner comprises a housing 106 comprising the pistol-grip part 107, and a tip 108 adapted for insertion in the mouth of the patient. In this example the scanner also is equipped with a button 103 which is an additional element providing user-interface functionality.

The example system as shown in FIG. 1, FIG. 2 and FIG. 3 comprises a device 100 which is a handheld intraoral scanner and a display 101 which is a computer screen. The operator 102 may be a dentist, an assistant and/or the like. In an example, the action performance or operation functionality of the device 100 is to record some intraoral 3D geometry, and the user interface functionality is to rotate, pan, and zoom the 3D model 105 of the scanned data on the computer screen 101. The integration of the user interface functionality in the device 100 is provided by motion sensors (not visible), which can be accelerometers inside the scanner 100, whose readings determine the orientation, as seen in FIGS. 2a and 2b, of the display on the screen of the 3D model 105 of the teeth acquired by the scanner 100. Additional functionality, e.g. to start/stop scanning, may be provided by the button 103 as seen in FIG. 3. In the example system, the button 103 is located where the user's index finger can reach it conveniently.

In FIG. 1 the dentist 102 uses two hands to hold the intraoral scanner 100 while scanning, but it is understood that the scanner 100 can also be held with one hand while scanning. The device 100 can also be held with one or two hands, while changing the perspective of the 3D model 105 in the display 101. The example shown in FIG. 1 thus illustrates the advantage of the touchless user interface functionality, because in many clinical situations, the operator 102 should maintain both hands clean, disinfected, or even sterile.

The 3D user interface functionality may be exploited in a separate location than the operation functionality. For the above intraoral scanning system example, the scanning operation is performed in the oral cavity of the patient, see FIG. 1, while the user interface functionality is more flexibly exploited when the scanner is outside the patient's mouth, see FIGS. 2 and 3.

FIG. 4 shows an example of a flow-chart of a method of interaction between a handheld device and a display.

In step 101 at least one action in a physical 3D environment is performed by means of the handheld device. This action may be the scanning of teeth as shown in FIG. 1.

12

In step 102 the physical 3D environment is visually represented by the at least one display. This may be the display of the 3D model of the scanned teeth as seen in FIG. 1.

In step 103 the view of the represented 3D environment shown on the display is remotely controlled on the display by means of the handheld device. This may be the control of the viewing angle of the 3D model as seen in FIG. 2.

All the steps of the method may be repeated one or more times. The order in which the steps are performed may be different than the order described above, which is indicated by the dotted lines in the figure. If one or more of the steps are performed more times, the order of the steps may also be different.

Although some embodiments have been described and shown in detail, the invention is not restricted to them, but may also be embodied in other ways within the scope of the subject matter defined in the following claims. In particular, it is to be understood that other embodiments may be utilised and structural and functional modifications may be made without departing from the scope of the present invention.

In device claims enumerating several means, several of these means can be embodied by one and the same item of hardware. The mere fact that certain measures are recited in mutually different dependent claims or described in different embodiments does not indicate that a combination of these measures cannot be used to advantage.

It should be emphasized that the term "comprises/comprising" when used in this specification is taken to specify the presence of stated features, integers, steps or components but does not preclude the presence or addition of one or more other features, integers, steps, components or groups thereof.

The features of the method described above and in the following may be implemented in software and carried out on a data processing system or other processing means caused by the execution of computer-executable instructions. The instructions may be program code means loaded in a memory, such as a RAM, from a storage medium or from another computer via a computer network. Alternatively, the described features may be implemented by hardwired circuitry instead of software or in combination with software.

## LITERATURE

- C. Graetzel, T. Fong, S. Grange, and C. Baur, A Non-Contact Mouse for Surgeon-Computer Interaction, *Technology and Health Care*, 12(3), 2004.
- Vogt S., Khamene A., Niemann H., Sauer F., An AR system with intuitive user interface for manipulation and visualization of 3D medical data, *Stud. Health Technol. Inform.* 2004; 98, pp. 397-403.

## EMBODIMENTS

The following embodiments relates to one aspect of the system as disclosed by the description herein.

1. A system comprising a handheld device and at least one display, where the handheld device is adapted for performing at least one action in a physical 3D environment, where the at least one display is adapted for visually representing the physical 3D environment, and where the handheld device is adapted for remotely controlling the view with which the 3D environment is represented on the display.

2. The system according to any one or more of the preceding embodiments, wherein the view is defined as viewing angle and/or viewing position.

3. The system according to any one or more of the preceding embodiments, wherein the handheld device is adapted for



remotely controlling the magnification with which the 3D environment is represented on the display.

4. The system according to any one or more of the preceding embodiments, wherein the handheld device is adapted for changing the rendering of the 3D environment on the display.

5. The system according to any one or more of the preceding embodiments, wherein the at least one action comprises one or more of:

measuring,  
recording,  
scanning,  
manipulating, and/or  
modifying.

6. The system according to any one or more of the preceding embodiments, wherein the 3D environment comprises one or more 3D objects.

7. The system according to any one or more of the preceding embodiments, wherein the handheld device is adapted to be held in one hand by an operator.

8. The system according to any one or more of the preceding embodiments, wherein the display is adapted to represent the 3D environment from multiple views.

9. The system according to any one or more of the preceding embodiments, wherein the view of the 3D environment represented in the at least one display is at least partly determined by the motion of the operator's hand holding said device.

10. The system according to any one or more of the preceding embodiments, wherein the magnification represented in the at least one display is at least partly determined by the motion of the operator's hand holding said device.

11. The system according to any one or more of the preceding embodiments, wherein the handheld device is adapted to record the 3D geometry of the 3D environment.

12. The system according to any one or more of the preceding embodiments, wherein the 3D geometry of the 3D environment is known a-priori.

13. The system according to any one or more of the preceding embodiments, wherein the handheld device comprises at least one user-interface element.

14. The system according to any one or more of the preceding embodiments, wherein the at least one user-interface element is at least one motion sensor.

15. The system according to any one or more of the preceding embodiments, wherein the handheld device comprises at least two motion sensors providing sensor fusion.

16. The system according to any one or more of the preceding embodiments, wherein the user interface functionality comprises the use of gestures.

17. The system according to any one or more of the preceding embodiments, wherein the gestures are detected by the at least one motion sensor.

18. The system according to any one or more of the preceding embodiments, wherein the handheld device comprises at least one user-interface element other than the at least one motion sensor.

19. The system according to any one or more of the preceding embodiments, wherein the at least one other user-interface element is a touch-sensitive element.

20. The system according to any one or more of the preceding embodiments, wherein the at least one other user-interface element is a button.

21. The system according to any one or more of the preceding embodiments, wherein the at least one other user-interface element is a scroll wheel.

22. The system according to any one or more of the preceding embodiments, wherein the handheld device is adapted

to change a viewing angle with which the 3D environment is represented on the at least one display.

23. The system according to any of the preceding embodiments, wherein the handheld device is adapted to change a magnification factor with which the 3D environment is represented on the at least one display.

24. The system according to any one or more of the preceding embodiments, wherein the handheld device is adapted to change a viewing position with which the 3D environment is represented on the at least one display.

25. The system according to any one or more of the preceding embodiments, wherein the view of the 3D environment comprises a viewing angle, a magnification factor, and/or a viewing position.

26. The system according to any one or more of the preceding embodiments, wherein the view of the 3D environment comprises rendering of texture and/or shading.

27. The system according to any one or more of the preceding embodiments, wherein the at least one display is divided into multiple regions, each showing the 3D environment with a different view.

28. The system according to any one or more of the preceding embodiments, wherein the 3D geometry comprises a 3D surface of the environment.

29. The system according to any one or more of the preceding embodiments, wherein the 3D geometry comprises a 3D volumetric representation of the environment.

30. The system according to any one or more of the preceding embodiments, wherein the handheld device is an infra-red 3D scanner.

31. The system according to any one or more of the preceding embodiments, wherein the handheld device is a surgical instrument.

32. The system according to any one or more of the preceding embodiments, wherein the handheld device is a mechanical tool.

33. The system according to any one or more of the preceding embodiments, wherein the handheld device is an infra-red 3D scanner.

34. The system according to any one or more of the preceding embodiments, wherein the at least one display is arranged separate from the handheld device.

35. The system according to any one or more of the preceding embodiments, wherein the at least one display is arranged on a cart.

36. The system according to any one or more of the preceding embodiments, wherein the at least one display is defined as a first display, and where the system further comprises a second display.

37. The system according to any one or more of the preceding embodiments, wherein the second display is arranged on the handheld device.

38. The system according to any one or more of the preceding embodiments, wherein the second display is arranged on the handheld device in a position such that the display is adapted to be viewed by the operator, while the operator is operating the handheld device.

39. The system according to any one or more of the preceding embodiments, wherein the second display indicates where the handheld device is positioned relative to the 3D environment.

40. The system according to any one or more of the preceding embodiments, wherein the first display and/or the second display provides instructions for the operator.

41. The system according to any one or more of the preceding embodiments, wherein visual information is provided to the operator on one or more means other than the first display.

42. The system according to any one or more of the preceding embodiments, wherein audible information to the operator is provided to the operator.

43. The system according to any one or more of the preceding embodiments, wherein the scanning is performed by means of LED scanning, laser light scanning, white light scanning, X-ray scanning, and/or CT scanning.

44. A method of interaction between a handheld device and at least one display, where the method comprises the steps of: performing at least one action in a physical 3D environment by means of the handheld device; visually representing the physical 3D environment by the at least one display; and remotely controlling the view of the represented 3D environment on the display by means of the handheld device.

45. A computer program product comprising program code means for causing a data processing system to perform the method of any one or more of the preceding embodiments, when said program code means are executed on the data processing system.

46. A computer program product according to the previous embodiment, comprising a computer-readable medium having stored there on the program code means.

The invention claimed is:

1. A scanning system for scanning a 3D environment, the scanning system comprising:

- a handheld device including an optical scanner, wherein the 3D environment to be scanned is selected by pointing the optical scanner at the 3D environment; and
- at least one display remotely connected to the handheld device,

wherein the handheld device is adapted for performing at least one scanning action in a physical 3D environment, and the at least one display is adapted for visually representing the physical 3D environment; and the handheld device includes a user interface for remotely controlling the display to adjust the view with which the 3D environment is represented on the display.

2. A system according to claim 1, wherein the handheld device is adapted to record the 3D geometry of the 3D environment.

3. A system according to claim 1, wherein the user interface includes means for manually switching between performing the at least one scanning action and remotely controlling the view.

4. The system according to claim 1, wherein the handheld device comprises at least one motion sensor.

5. The system according to claim 4, wherein the view of the 3D environment represented in the at least one display is at least partly determined by the at least one motion sensor.

6. The system according to claim 4, wherein functionality of the user interface comprises a use of gestures.

7. The system according to claim 6, wherein the gestures are detected by the at least one motion sensor.

8. The system according to claim 4, wherein the user-interface is other than the at least one motion sensor.

9. The system according to claim 1, wherein the handheld device is adapted to change a viewing angle with which the 3D environment is represented on the at least one display.

10. The system according to claim 1, wherein the handheld device is adapted to change a magnification factor with which the 3D environment is represented on the at least one display.

11. The system according to claim 1, wherein the handheld device is an intra-oral 3D scanner.

12. The system according to claim 1, wherein the handheld device includes a surgical instrument.

13. The system according to claim 1, wherein the handheld device includes a mechanical tool.

14. The system according to claim 1, wherein the handheld device is an in-ear 3D scanner.

15. The system according to claim 1, wherein the at least one display is defined as a first display, and where the system further comprises a second display.

16. The system according to claim 15, wherein the second display indicates where the handheld device is positioned relative to the 3D environment.

17. The system according to claim 15, wherein the first display and/or the second display provides instructions for the operator.

18. The system according to claim 1, wherein audible information is provided to the operator.

19. A system comprising:  
a handheld device and at least one display;  
wherein the handheld device is adapted for switching between performing at least one action in a physical 3D environment, wherein the at least one display is adapted for visually representing the physical 3D environment; and remotely controlling the display to adjust the view with which the 3D environment is represented on the display;

wherein the handheld device is an intra-oral 3D scanner and the at least one action performed in the physical 3D environment is scanning and that the view is remotely controlled by at least one motion sensor arranged in the handheld device, and wherein an actuator provided on the handheld device switches between performing the at least one action and remotely controlling the view.

\* \* \* \* \*

## SCORE Placeholder Sheet for IFW Content

Application Number: 16526281

Document Date: 07/30/2019

The presence of this form in the IFW record indicates that the following document type was received in electronic format on the date identified above. This content is stored in the SCORE database.

Since this was an electronic submission, there is no physical artifact folder, no artifact folder is recorded in PALM, and no paper documents or physical media exist. The TIFF images in the IFW record were created from the original documents that are stored in SCORE.

- Drawing

At the time of document entry (noted above):

- USPTO employees may access SCORE content via DAV or via the SCORE web page.
- External customers may access SCORE content via PAIR using the Supplemental Content tab.