



US005181181A

United States Patent [19]

[11] Patent Number: **5,181,181**

Glynn

[45] Date of Patent: **Jan. 19, 1993**

[54] **COMPUTER APPARATUS INPUT DEVICE FOR THREE-DIMENSIONAL INFORMATION**

[75] Inventor: **Brian J. Glynn, Merritt Island, Fla.**

[73] Assignee: **Triton Technologies, Inc., Burke, Va.**

[21] Appl. No.: **588,824**

[22] Filed: **Sep. 27, 1990**

[51] Int. Cl.⁵ **G01P 7/00; G01P 15/00; G09G 1/00**

[52] U.S. Cl. **364/566; 340/710; 364/709.11**

[58] Field of Search **364/560, 453, 709.11, 364/565, 566; 340/710, 706; 178/18-20; 73/505**

[56] **References Cited**

U.S. PATENT DOCUMENTS

3,541,541	11/1970	Engelbart	178/18 X
3,835,464	9/1974	Rider	340/710
3,892,963	7/1975	Hawley et al.	250/231.16
3,898,445	8/1975	MacLeod et al.	356/141
3,987,685	10/1976	Opocensky	340/710
4,241,409	12/1980	Nolf	340/705
4,390,873	6/1983	Kirsch	340/710
4,409,479	10/1983	Sprague et al.	33/1 M
4,578,674	3/1986	Baker et al.	340/710
4,608,641	8/1986	Snell	364/453 X
4,617,634	10/1986	Izumida et al.	364/453 X
4,682,159	7/1987	Davison	340/706
4,688,184	8/1987	Taniguti et al.	364/560
4,695,831	9/1987	Shinn	340/707

4,754,268	6/1988	Mori	340/710
4,766,423	8/1988	Ono et al.	340/709
4,787,051	11/1988	Olson	364/518
4,812,829	3/1989	Ebina et al.	340/709
4,835,528	5/1989	Flinchbaugh	340/709
4,839,838	6/1989	LaBiche et al.	364/709.11
4,887,230	12/1989	Noguchi et al.	364/560
4,916,650	4/1990	Oikawa	364/453 X
4,922,444	5/1990	Baba	364/566
5,001,647	3/1991	Rapiejko et al.	364/453

Primary Examiner—Thomas G. Black
Assistant Examiner—Michael Zanelli
Attorney, Agent, or Firm—Burns, Doane, Swecker & Mathis

[57] **ABSTRACT**

A mouse which senses six degrees of motion arising from movement of the mouse within three dimensions. A hand-held device includes three accelerometers for sensing linear translation along three axes of a Cartesian coordinate system and three angular rate sensors for sensing angular rotation about the three axes. Signals produced by the sensors are processed to permit the acceleration, velocity and relative position and attitude of the device to be conveyed to a computer. Thus, a person may interact with a computer with six degrees of motion in three-dimensional space. Computer interface ports and unique address identification ensure proper communication with the computer regardless of the orientation of the mouse.

21 Claims, 7 Drawing Sheets

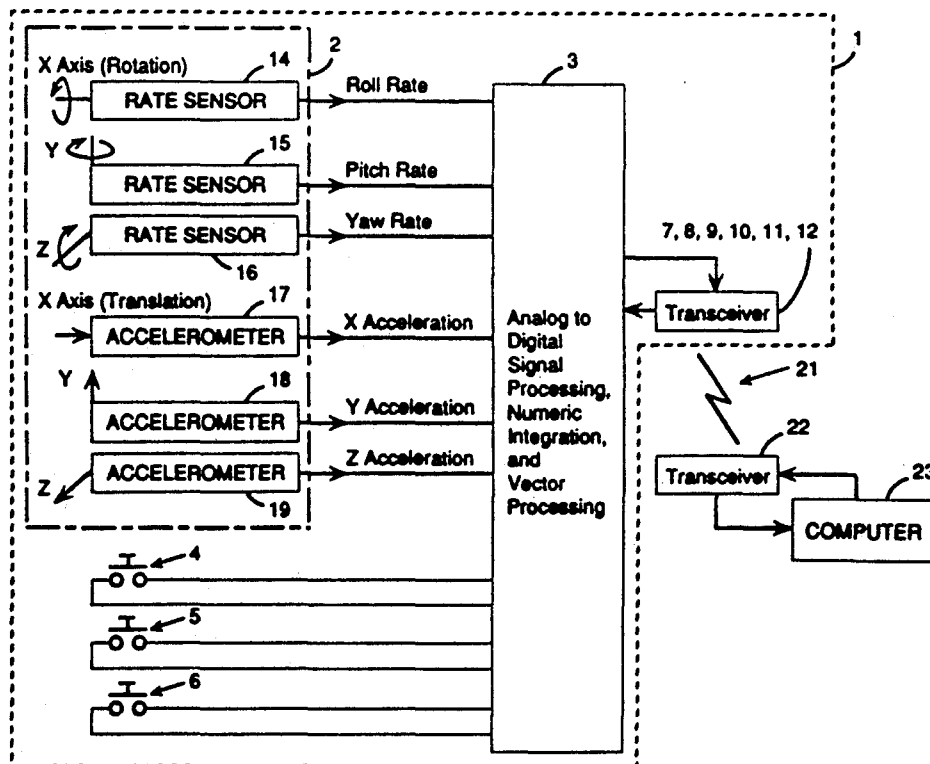

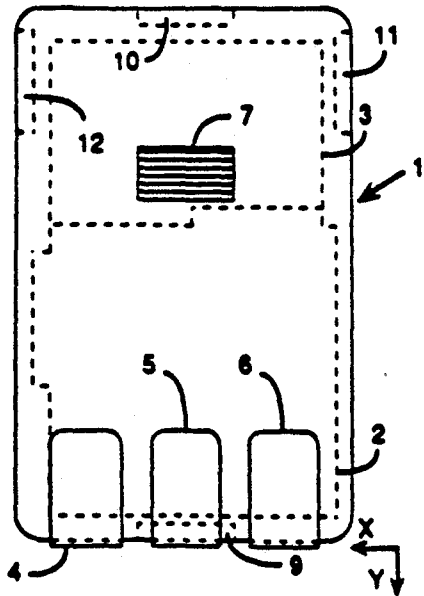

FIG. 1(a)

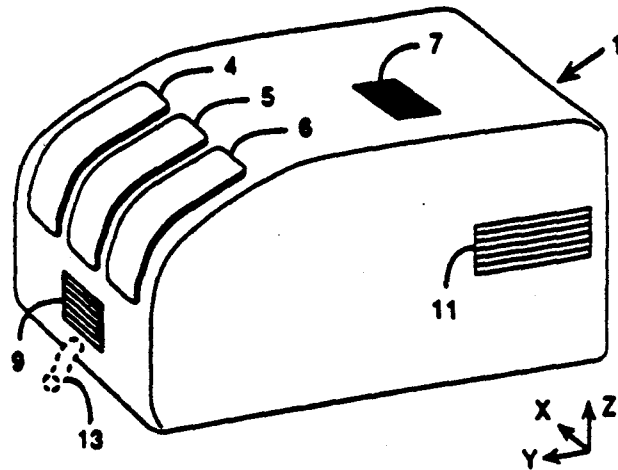

FIG. 1(d)

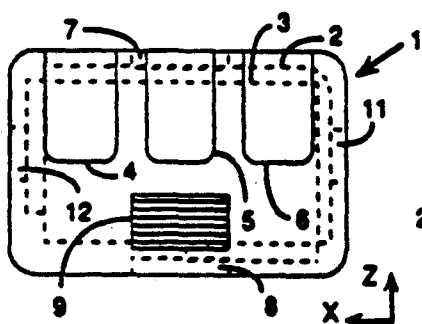

FIG. 1(b)

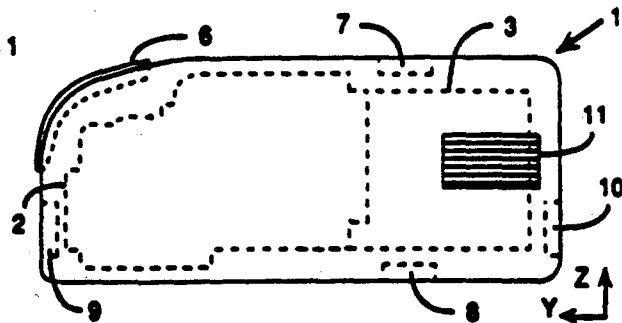

FIG. 1(c)

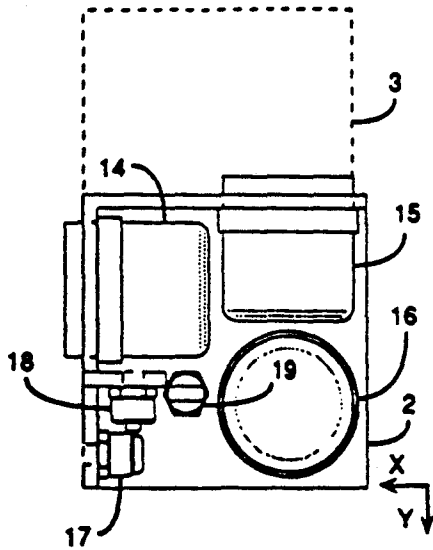

FIG. 2(a)

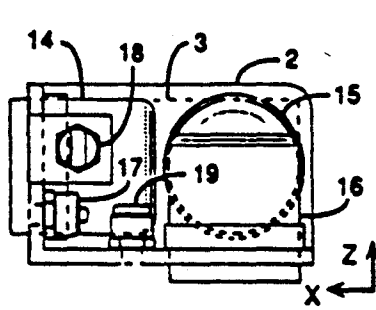

FIG. 2(b)

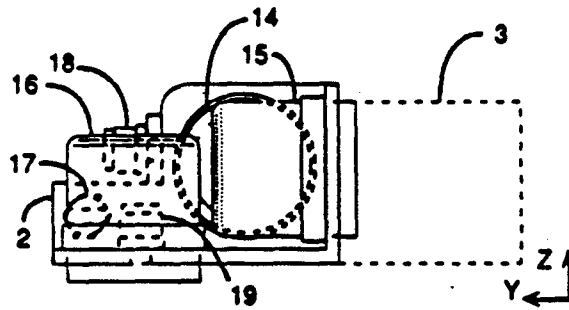

FIG. 2(c)

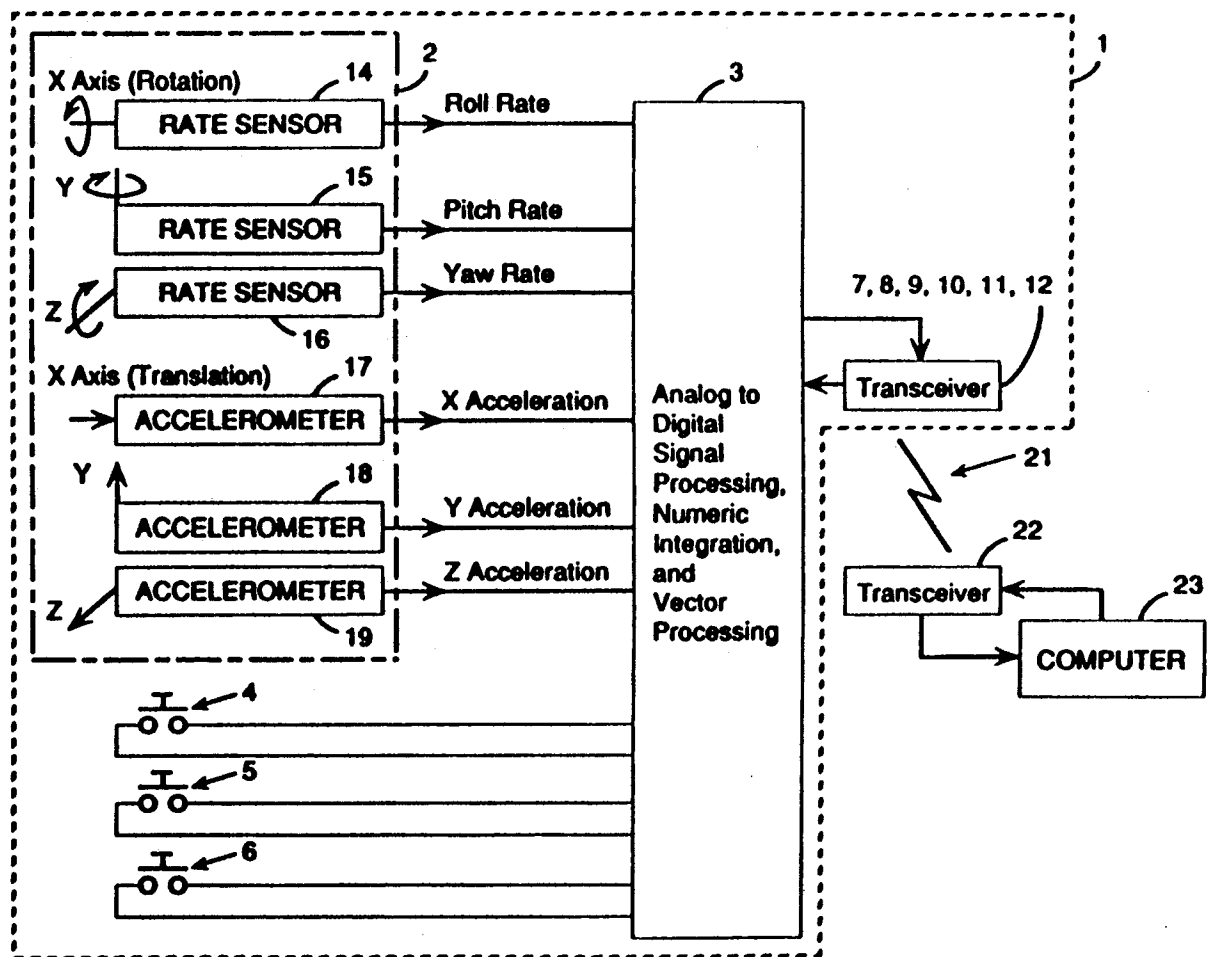

FIG. 3

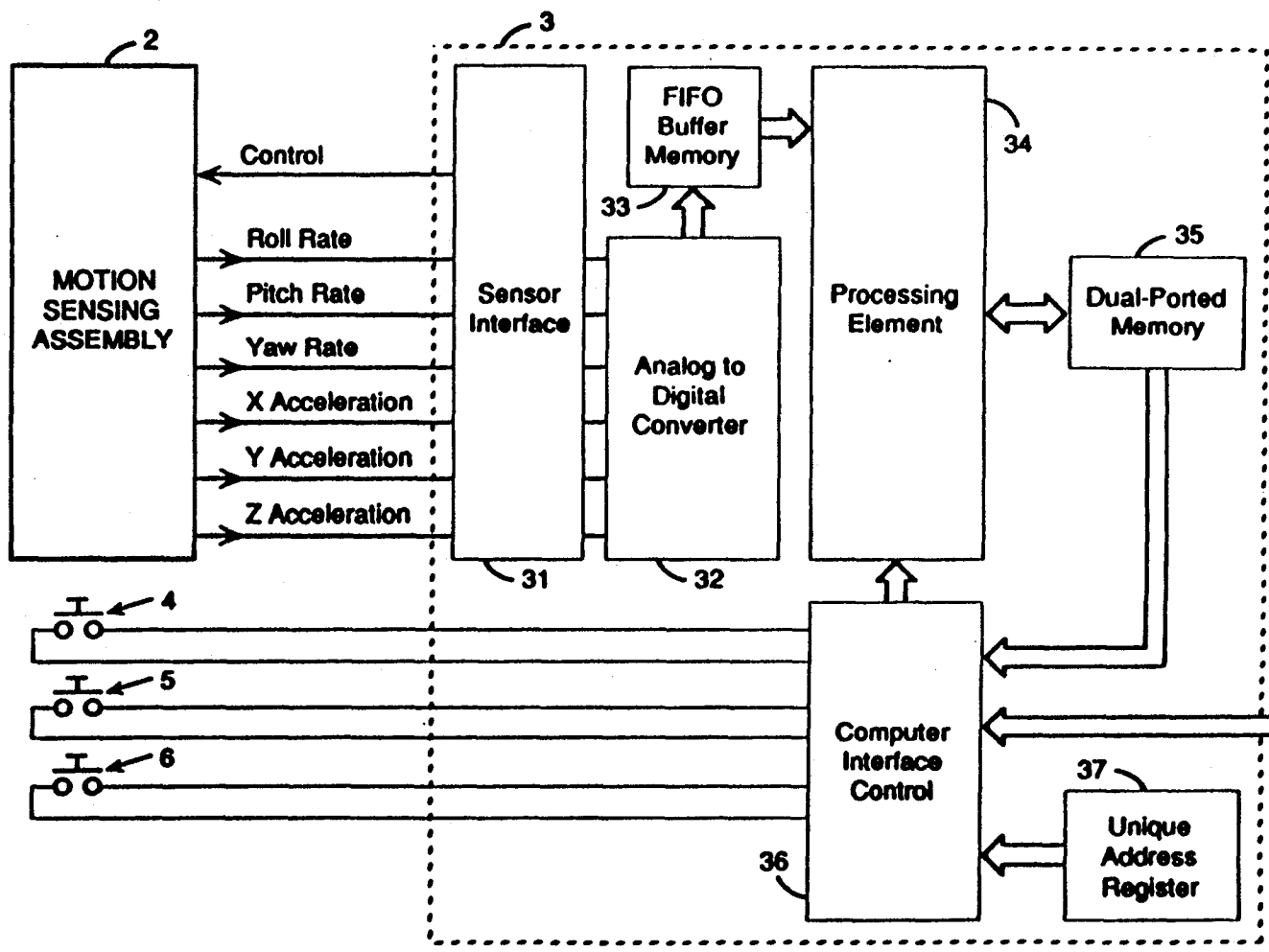

FIG. 4

Explore Litigation Insights

Docket Alarm provides insights to develop a more informed litigation strategy and the peace of mind of knowing you're on top of things.

Real-Time Litigation Alerts



Keep your litigation team up-to-date with **real-time alerts** and advanced team management tools built for the enterprise, all while greatly reducing PACER spend.

Our comprehensive service means we can handle Federal, State, and Administrative courts across the country.

Advanced Docket Research



With over 230 million records, Docket Alarm's cloud-native docket research platform finds what other services can't. Coverage includes Federal, State, plus PTAB, TTAB, ITC and NLRB decisions, all in one place.

Identify arguments that have been successful in the past with full text, pinpoint searching. Link to case law cited within any court document via Fastcase.

Analytics At Your Fingertips



Learn what happened the last time a particular judge, opposing counsel or company faced cases similar to yours.

Advanced out-of-the-box PTAB and TTAB analytics are always at your fingertips.

API

Docket Alarm offers a powerful API (application programming interface) to developers that want to integrate case filings into their apps.

LAW FIRMS

Build custom dashboards for your attorneys and clients with live data direct from the court.

Automate many repetitive legal tasks like conflict checks, document management, and marketing.

FINANCIAL INSTITUTIONS

Litigation and bankruptcy checks for companies and debtors.

E-DISCOVERY AND LEGAL VENDORS

Sync your system to PACER to automate legal marketing.