



US006645148B2

(12) **United States Patent**
Nguyen-Dinh et al.

(10) **Patent No.:** US 6,645,148 B2
(45) **Date of Patent:** Nov. 11, 2003

(54) **ULTRASONIC PROBE INCLUDING POINTING DEVICES FOR REMOTELY CONTROLLING FUNCTIONS OF AN ASSOCIATED IMAGING SYSTEM**

5,323,767 A	*	6/1994	Lafferty et al.	600/109
5,351,692 A	*	10/1994	Dow et al.	600/459
5,722,412 A		3/1998	Pflugrath et al.	
5,738,099 A	*	4/1998	Chang	600/437
5,758,649 A	*	6/1998	Iwashita et al.	600/459
6,135,958 A		10/2000	Mikula-Curtis et al.	

(75) Inventors: **An Nguyen-Dinh**, Valleres (FR); **Aimé Flesch**, Andrésy (FR)

(73) Assignee: **Vernon**, Tours Cedex (FR)

(*) Notice: Subject to any disclaimer, the term of this patent is extended or adjusted under 35 U.S.C. 154(b) by 53 days.

FOREIGN PATENT DOCUMENTS

EP	139574	*	5/1985
JP	9-56716	*	3/1997

* cited by examiner

(21) Appl. No.: **09/811,147**

(22) Filed: **Mar. 20, 2001**

(65) **Prior Publication Data**

US 2002/0138007 A1 Sep. 26, 2002

(51) **Int. Cl.⁷** **A61B 8/14**

(52) **U.S. Cl.** **600/459; 600/462**

(58) **Field of Search** **600/459, 462, 600/463-465**

(56) **References Cited**

U.S. PATENT DOCUMENTS

5,295,485 A 3/1994 Shinomura et al.

Primary Examiner—John A. Jeffery

(74) *Attorney, Agent, or Firm*—Larson & Taylor, PLC

(57) **ABSTRACT**

An ultrasonic probe is provided for use in medical diagnostic applications. The probe includes one or more ultrasonic transducers disposed in an external housing and a plurality of cables disposed in a common sheath. A pointing device, such as a trackball, rocking-key device or the like, is mounted on the probe housing for controlling a plurality of functions of a remote imaging system associated with the probe.

22 Claims, 2 Drawing Sheets

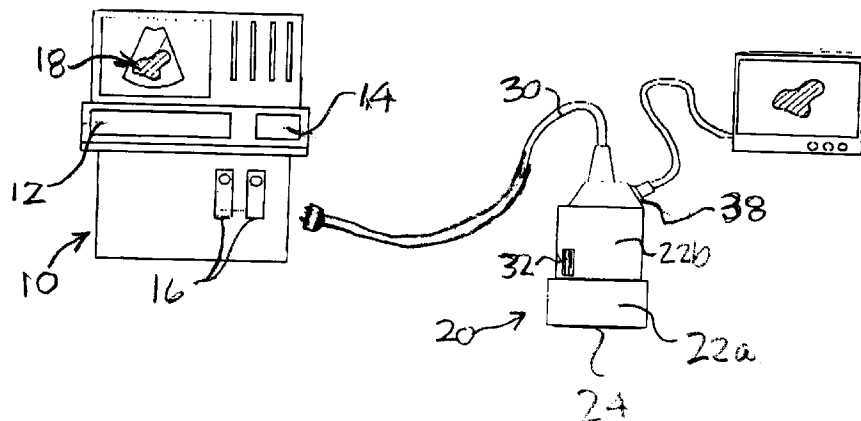
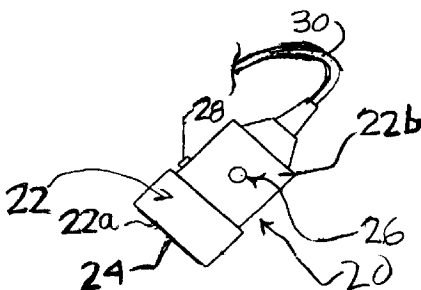

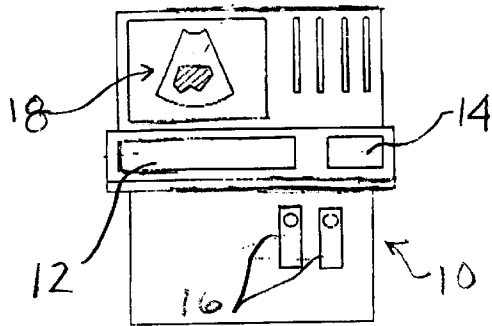

Fig. 1
PRIOR ART

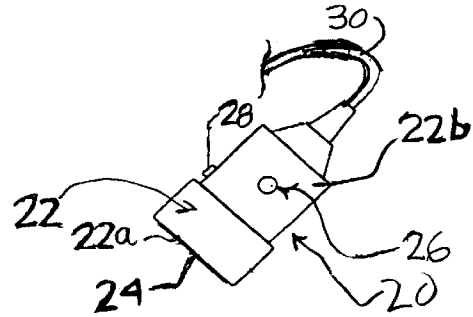

Fig. 2

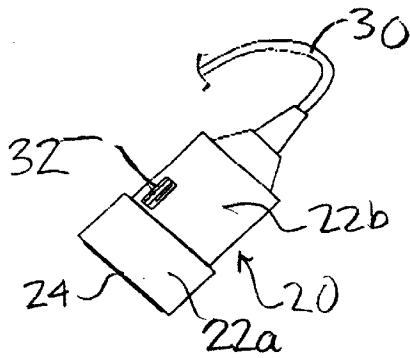

Fig. 3

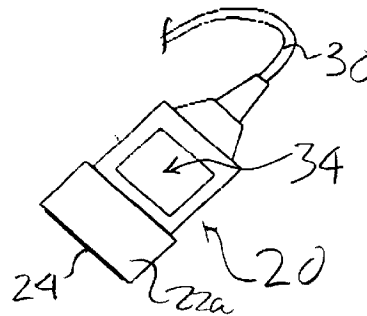

Fig. 4

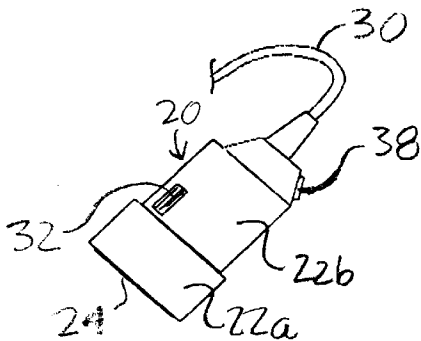

Fig. 6

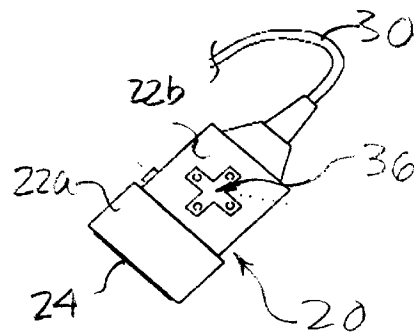
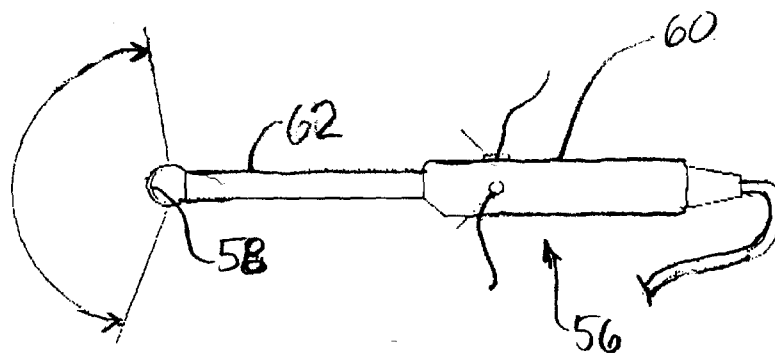
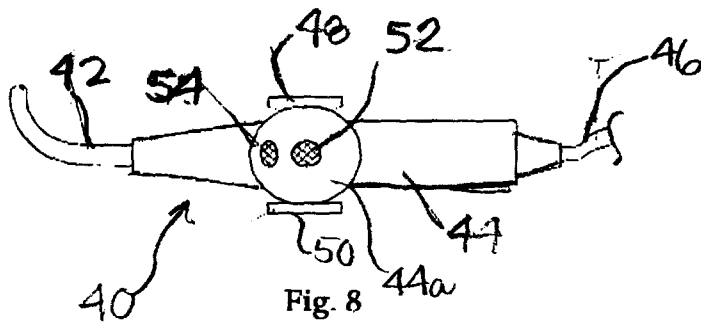
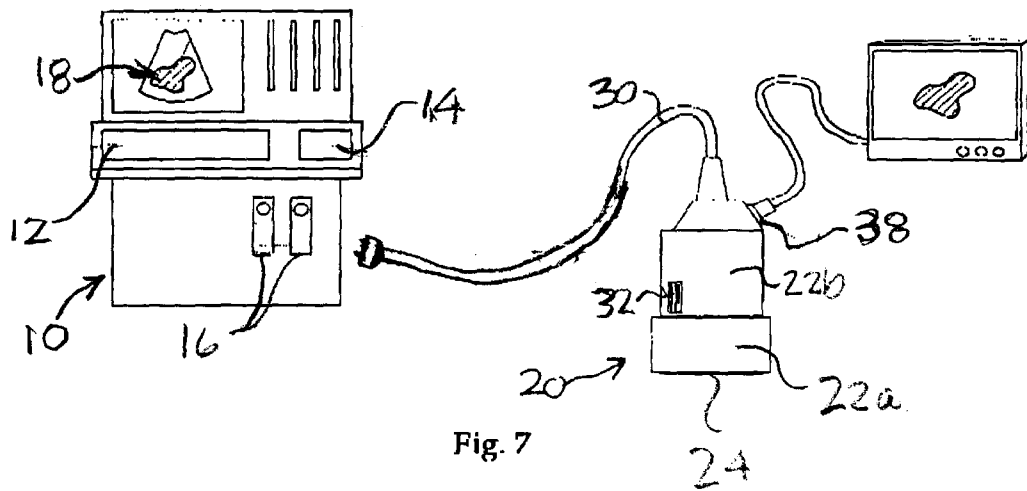

Fig. 5



**ULTRASONIC PROBE INCLUDING
POINTING DEVICES FOR REMOTELY
CONTROLLING FUNCTIONS OF AN
ASSOCIATED IMAGING SYSTEM**

BACKGROUND OF THE INVENTION

1. Field of the Invention

The present invention relates to ultrasonic probes used for diagnostic applications, and more particularly, for human body imaging.

2. Related Art

Diagnosing human organs using ultrasound is a well known procedure. Ultrasonic probes are used which employ ultrasonic transducers, with ultrasonic waves being directed from the transducer surface so as to travel through biologic structures under examination. Reflections are obtained each time the ultrasonic waves encounter impedance variation interfaces. As a result, returned echoes are received and processed by the imaging system. Summing all scanning lines received from the transducer provides an image, and the number of scanning lines and the depth of examination govern the scanning rate. Generally speaking, standard ultrasonic probes use a one dimensional (1D) transducer wherein the transducer elements are linearly arranged and no scanning control is implemented in the elevation direction. However, in some probe configurations, multi-dimensional probes (1.5D or 2D) are provided, and the transducer elements are thus arranged in a matrix so as to provide 3D steering capabilities.

Conventionally, ultrasonic probes are connected to a mainframe which is responsible for the processing of electrical signals produced by the probe transducer. The system performs an image capture or rendering operation using data from the region being scanned, and the images so obtained are produced by the synthesizing of information based on a number of different parameters, e.g., the transducer geometry, the number of scanning lines, the depth of examination and the transducer frequency. In common practice, the mainframes are provided with large advanced image settings to produce a diagnosing scan in conformance with the organ structure being examined. Typically, by using a trackball or sensitive pad of an associated keyboard, the imaging system enables a user to access most of the controls for scanning characteristics such as the frame rate, number of focal points, depth, and angle aperture, as well as other settings regarding the mode of scanning, including, e.g., CFM (color flow mapping), B-Mode, C-Mode, CW (continuous wave) and PW (pulsed wave) Doppler and the like, whereas other controls such as master gain, TGC (Time Gain Control), dynamic range, freeze, and measuring tools (for distance, surface, volume and the like) are often provided through activation of direct control buttons or by using cursors for rapid access. Given the complexity of image controls and the close attention that is required in making medical a diagnosis, ultrasound scanning of this kind can, in practice, be a very difficult task.

Considering further prior art of interest, U.S. Pat. No. 5,295,485 to Shinimura and U.S. Pat. No. 5,722,412 to Pflugrath both disclose a handheld device which includes, in the same casing, a transducer array, ASICs (Application Specific Integrated Circuit) or conventional signal processing circuits and a display monitor. The device is battery powered and thus can be used at any desired location. However, integration of all of the various components necessary to the image processing operation results in an

apparatus which is heavy and has a reduced lifetime. Further, advanced image processing functionalities like those available in conventional mainframe-based systems cannot always be implemented so that only preliminary diagnostic procedures can be carried out with such prior art devices in attempting to determine the appropriate medical intervention needed by the patient. Accordingly, these devices are essentially dedicated to emergency use where portability and autonomy is required.

In U.S. Pat. No. 6,135,958 to Mikula-Curtis, an ultrasonic scanner is equipped with a remote user interface, including a touch-pad pointing device, so the interface can be placed closer to the user and further away from the ultrasound machine. Such equipment raises the level of comfort in operation the equipment but the use of both hands is still mandatory.

SUMMARY OF THE INVENTION

In accordance with the invention, in order to overcome the drawbacks of prior art devices discussed above, there is provided an ultrasonic probe that includes a pointing device mounted on the probe casing or housing so as to enable a user to remotely control the basic functions of the associated imaging system. This pointing device is, in essence, an extension of the original setting controls provided by the system keyboard, so that a user can, at his or her option, either access the major image settings from the remote pointing device or access all of the functions of the system using the system keyboard, the two system interfaces being operable in parallel.

The probe and associated imaging system of the present invention reflect a new approach to operating ultrasonic apparatus. Unlike the conventional systems described above wherein the scanning probe and control interface are separate units and a user must manipulate the ultrasonic instrument with both hands (one for moving and steering the acoustic wave and the other for controlling the image features) and unlike a handheld scanner wherein severe compromises must be made to provide a compact volume at the detriment of image quality, the present apparatus provides a user with an imaging system which comprises at least one ultrasonic probe equipped with a limited remote user interface so that the usual functions of the imaging system can be controlled from probe, thereby significantly improving the comfort level of one using the probe during an examination.

In one embodiment of the invention, the user interface comprises a pointing device located on the probe casing, and the pointing device is a commercially available device as that used in a Notebook computer or in Gamepads or the like. Advantageously, the pointing device is located on a main face of the casing or the housing where there is more room to operate the device and easy access may be had to the device. In connecting the pointing device to the imaging system, a number of suitable techniques can be used including such as single connecting wires or an IR (infrared) line. Of course, there are a wide variety of commercially available pointing devices, and the present invention can employ most, if not all of these, including, in accordance with preferred embodiments of the invention: a sensitive pad controlled by directional actions, a rocking key pointer device, scrolling devices, a track-ball or the like. Among the important manufacturers of these devices are Fujitsu, Techtronics, and InSolutions Corp.

An important advantage of the present invention is the improvement provided thereby in working condition of the

sonographers as well as in patient comfort, afforded by putting control of the basic settings of the system at the ready disposition of the user of the probe so as to permit him or her to deal better with the patient. Additional features of the invention include the provision of a one-touch image storage and of a control capability for other optional equipment (e.g., a therapy system or drug delivery functions).

Further features and advantages of the present invention will be set forth in, or apparent from, the detailed description of preferred embodiments thereof which follows.

BRIEF DESCRIPTION OF THE DRAWINGS

FIG. 1 is a schematic front elevational view of a prior art ultrasonic imaging apparatus;

FIGS. 2 to 6 are front elevational views of ultrasonic probes in accordance with different preferred embodiments of the invention;

FIG. 7 is a front elevational view of the embodiment of FIG. 5 in use;

FIG. 8 is a side elevational view of yet another embodiment of the invention; and

FIG. 9 is a side elevational view of a further embodiment of the invention.

DESCRIPTION OF THE PREFERRED EMBODIMENTS

Before considering the present invention in more detail, some general background will be considered. Ultrasonic probes of the type described here generally include a transducer or transducing part embedded in or housed within a shielded plastic case or housing. Commonly, the ultrasonic imaging transducers that are used employ either a moving transducing element or an electronic scanning array transducer. In the first case, the transducer is moved to scan a surface while, in the second case, an acoustic propagation path is produced by electronically switching the transducer elements or aperture along the array. It is noted that this electronic scanning technique using a transducer array is well known to those skilled in the corresponding art so that further description thereof will be dispensed with. In all cases, the probes have a front face made of acoustically transparent material in order to not disturb the ultrasonic propagation. Otherwise, moving transducing devices require a specific coupling arrangement to operate.

Continuing the general description of the background of the invention, during a medical diagnosis using conventional ultrasonic imaging equipment the ultrasonic scanner is disposed in the vicinity of the operator and, therefore, the patient. The imaging probe is then positioned on the region of body to be imaged. Ultrasonic energy is transmitted and received through the transducer and the region to be diagnosed is generally displayed in sliced planes (a 1D image). The scanned section of organ is displayed in a gray scale image that is obtained by quantization of analog signals derived from returned echoes.

As indicated above, in actual operation, the scanning process is substantially more difficult and less effective to carry out than just described. Indeed, the ultrasonic waves emanating from the transducer are frequency bounded and subject to physical restraints of acoustic wave propagation. As a consequence, attenuation and impedance interface mismatches must be taken into account in the signal processing procedure. Accordingly, in order to display the image with equal contrast intensity, the imaging system must compensate for any attenuation of the frequency and ampli-

tude of the signals travelling through the propagation medium. Therefore, frequency filters, and variable gain compensation techniques are used in processing the RF signals.

Others settings which are important in medical diagnosis are angle of view, the focus number and the depth of examination. Of course, control of most of these settings is provided by the system keyboard and this control may be effected by manipulation of various control buttons and/or trackball controls using scrolling menus. In practice, and in a manner designed to shorten the machine setup period, specific user diagnosis configurations are often stored in the system memory and then simply have to be loaded by the operator, so that, in normal use, only gain and focus controls are varied or adjusted during a diagnostic examination. However, depending on the morphology of the patient, the scanning area covered and the dynamic range must be adjusted during an examination to enhance the visual perception provided of the region of interest.

With this background, it would be appreciated that the provision of a pointing device such as a trackball or the like directly mounted on the ultrasonic probe will afford major gains in comfort and ease of use to the operator, who will now be able to easily and rapidly access these controls and, therefore, better attend to the patient. Using a single hand, the operator is capable of simultaneously selecting the scanning planes, controlling the gain of the image and modifying the settings for dynamic range or focus without any manipulation of the system keyboard. These features are of even greater significance as applied to endocavity probes (e.g., endorectal or endovaginal devices) and surgical imaging instruments such as endoscopes, laparoscopes or intravascular devices, where particular skill in manipulating the instruments is required. Moreover, the invention when applied to NDT transducers enables an expanded field of use of the instrument such as in severe environmental conditions or adverse temperature conditions, and when applied to ultrasonic probes for controlling another apparatus such as a therapy or drug delivery unit, provides added versatility. Further, an ultrasonic probe in accordance with the invention is advantageously equipped with a video output connector compatible with a RGB video output or a S-video output which can be plugged into a LCD display or an additional monitor, so that the probe is capable of operating remotely from its associated mainframe.

Before describing specific embodiments of the invention, the desirable characteristics of a suitable pointing device will be considered. It is to be understood that the pointing devices employed in accordance with the invention are preferably disposed on a main surface or face of the probe housing or case.

Although a trackball device may be used, this type of device is generally to be avoided because cleaning thereof is difficult (dust and dirt can contaminate the interstices between trackball and the casing so that sealed or otherwise completely covered devices are preferred for medical applications).

One pointing device that is particularly suitable for the purposes of the invention is a rocking key device such as that supplied by Fujitsu Takamisawa. The device is comprised of a small PCB (printed circuit board) on which are integrated a rocking key dome-type component and its associated electronic control circuits. This allows the device to be fitted to a digital controller to produce PS2 output similar to that of a conventional mouse. The dome-type pointing component is sealed and provides both ballistic and acceleration

Explore Litigation Insights

Docket Alarm provides insights to develop a more informed litigation strategy and the peace of mind of knowing you're on top of things.

Real-Time Litigation Alerts



Keep your litigation team up-to-date with **real-time alerts** and advanced team management tools built for the enterprise, all while greatly reducing PACER spend.

Our comprehensive service means we can handle Federal, State, and Administrative courts across the country.

Advanced Docket Research



With over 230 million records, Docket Alarm's cloud-native docket research platform finds what other services can't. Coverage includes Federal, State, plus PTAB, TTAB, ITC and NLRB decisions, all in one place.

Identify arguments that have been successful in the past with full text, pinpoint searching. Link to case law cited within any court document via Fastcase.

Analytics At Your Fingertips



Learn what happened the last time a particular judge, opposing counsel or company faced cases similar to yours.

Advanced out-of-the-box PTAB and TTAB analytics are always at your fingertips.

API

Docket Alarm offers a powerful API (application programming interface) to developers that want to integrate case filings into their apps.

LAW FIRMS

Build custom dashboards for your attorneys and clients with live data direct from the court.

Automate many repetitive legal tasks like conflict checks, document management, and marketing.

FINANCIAL INSTITUTIONS

Litigation and bankruptcy checks for companies and debtors.

E-DISCOVERY AND LEGAL VENDORS

Sync your system to PACER to automate legal marketing.