



US005563343A

United States Patent [19]

[11] Patent Number: **5,563,343**

Shaw et al.

[45] Date of Patent: **Oct. 8, 1996**

[54] **MICROELECTROMECHANICAL LATERAL ACCELEROMETER**

5,228,341	7/1993	Tsuchitani	73/517 R
5,235,187	8/1993	Arney et al.	250/306
5,314,572	5/1994	Core	156/643
5,345,824	9/1994	Sherman	73/517 R
5,353,641	10/1994	Tang	73/514.18
5,357,803	10/1994	Lane	73/514.18

[75] Inventors: **Kevin A. Shaw; Scott G. Adams; Noel C. MacDonald**, all of Ithaca, N.Y.

[73] Assignee: **Cornell Research Foundation, Inc.**, Ithaca, N.Y.

OTHER PUBLICATIONS

[21] Appl. No.: **67,264**

[22] Filed: **May 26, 1993**

[51] Int. Cl.⁶ **G01P 15/08**

[52] U.S. Cl. **73/514.18; 73/514.24**

[58] Field of Search 73/517 R, 514, 73/515, 516 R, 517 B, 514.18, 514.21, 514.24, 514.32, 514.35, 514.38, 514.36, 514.17

Accelerometer's Micromachined Mass "Moves" In Plane of IC; On-Chip Circuit Controls It And Senses G With Force-Balance Techniques. Airbags Boom When IC Accelerometer Sees 50G. Electronic Design, Aug. 8, 1991, pp. 45-56. Zhang et al., "A RIE Process for Submicron, Silicon Electromechanical Structures", IOP Publishing Ltd., 1992, pp. 31-38.

Wilson et al., "Highly Selective, High Rate Tungsten Deposition", Materials Research Society, 1985, pp. 35-43.

Zhang et al. "An RIE Process for Submicron, Silicon Electromechanical Structures", IEEE, May 24, 1991, pp. 520-523.

Arney et al., "Formation of Submicron Silicon-on-Insulator Structures by Lateral Oxidation of Substrate-Silicon Islands", J. Vac. Sci. Technol. B 6(1), Jan./Feb. 1988, pp. 341-345.

Payne, R. S., et al. "Surface Micromachined Accelerometer: A Technology Update". SAE International, pp. 127-135 (Feb. 25-Mar. 1, 1991).

Primary Examiner—Hezron E. Williams

Assistant Examiner—Christine K. Oda

Attorney, Agent, or Firm—Jones, Tullar & Cooper, P.C.

[56] References Cited

U.S. PATENT DOCUMENTS

3,835,338	9/1974	Martin	310/331
4,381,672	5/1983	O'Connor et al.	73/505
4,437,226	3/1984	Soclof	437/55
4,553,436	11/1985	Hansson	73/514.33
4,670,092	6/1987	Motamedi	156/643
4,685,198	8/1987	Kawakita et al.	437/73
4,706,374	11/1987	Murakami	437/225
4,746,621	5/1988	Thomas et al.	437/24
4,750,363	6/1988	Norling	73/517 R
4,772,928	9/1988	Dietrich et al.	257/254
4,776,924	10/1988	Delapierre	156/647
4,845,048	7/1989	Tamaki et al.	437/62
4,851,080	7/1989	Howe et al.	156/647
4,867,842	9/1989	Bohrer et al.	156/647
4,945,765	8/1990	Roszhart	73/514.29
4,981,552	1/1991	Mikkor	156/647
5,045,152	9/1991	Sickafus	156/653
5,072,288	12/1991	MacDonald	257/420
5,095,752	3/1992	Suzuki et al.	73/514.32
5,121,180	6/1992	Beringhouse et al.	73/514.34
5,126,812	6/1992	Greiff	257/417
5,149,673	9/1992	MacDonald et al.	437/192
5,179,499	1/1993	MacDonald et al.	361/313
5,198,390	3/1993	MacDonald et al.	437/203
5,205,171	4/1993	O'Brien et al.	73/514.18

[57] ABSTRACT

A microelectromechanical accelerometer having submicron features is fabricated from a single crystal silicon substrate. The accelerometer includes a movable portion incorporating an axial beam carrying laterally-extending high aspect ratio released fingers cantilevered above the floor of a cavity formed in the substrate during the fabrication process. The movable portion is supported by restoring springs having controllable flexibility to vary the resonant frequency of the structure. A multiple-beam structure provides stiffness in the movable portion for accuracy.

52 Claims, 5 Drawing Sheets

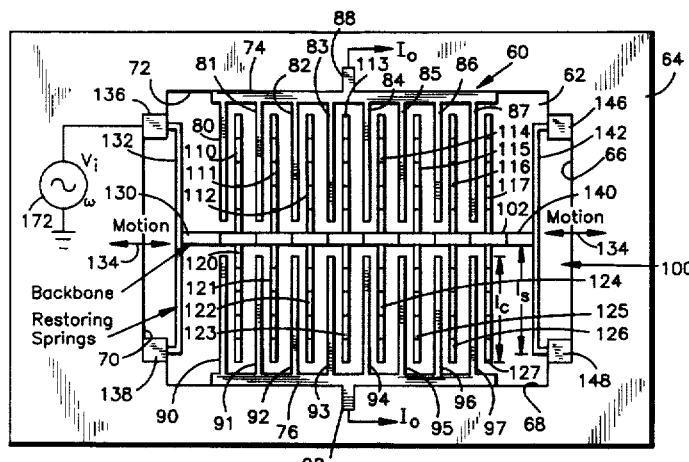

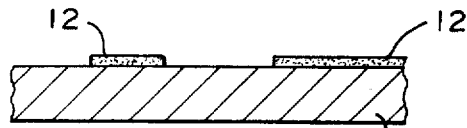

FIG. 1

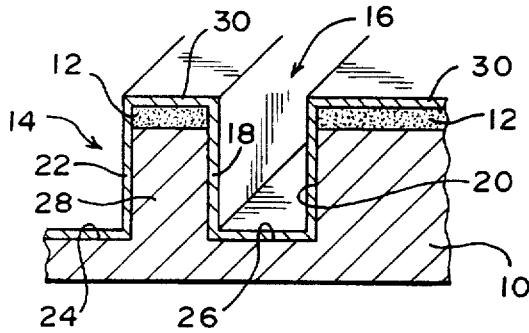

FIG. 2

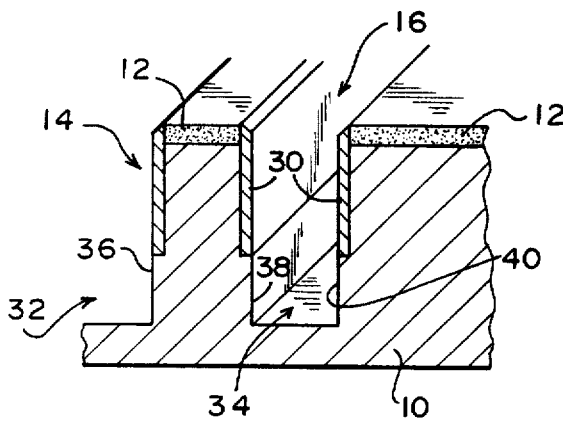

FIG. 3

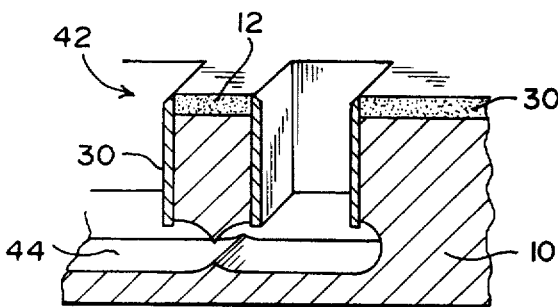

FIG. 4

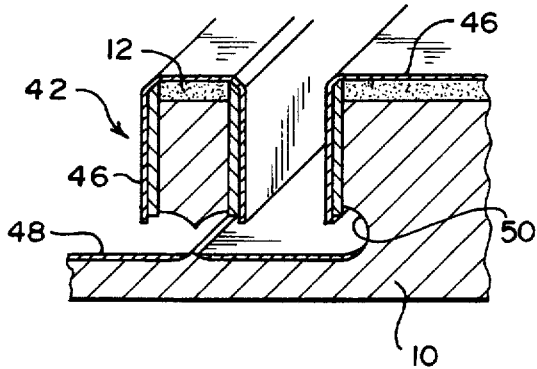

FIG. 5

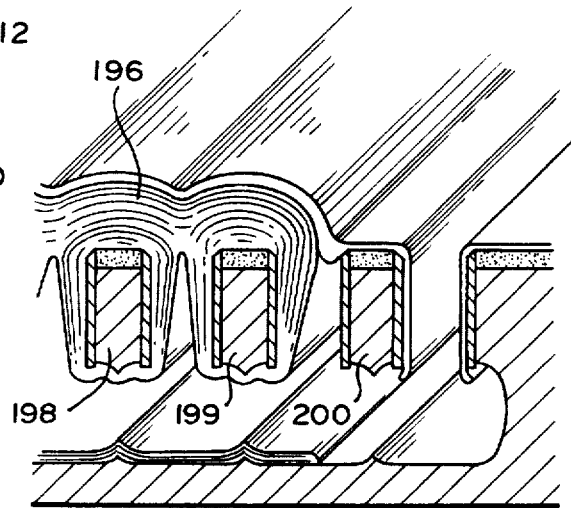

FIG. 9

FIG. 6

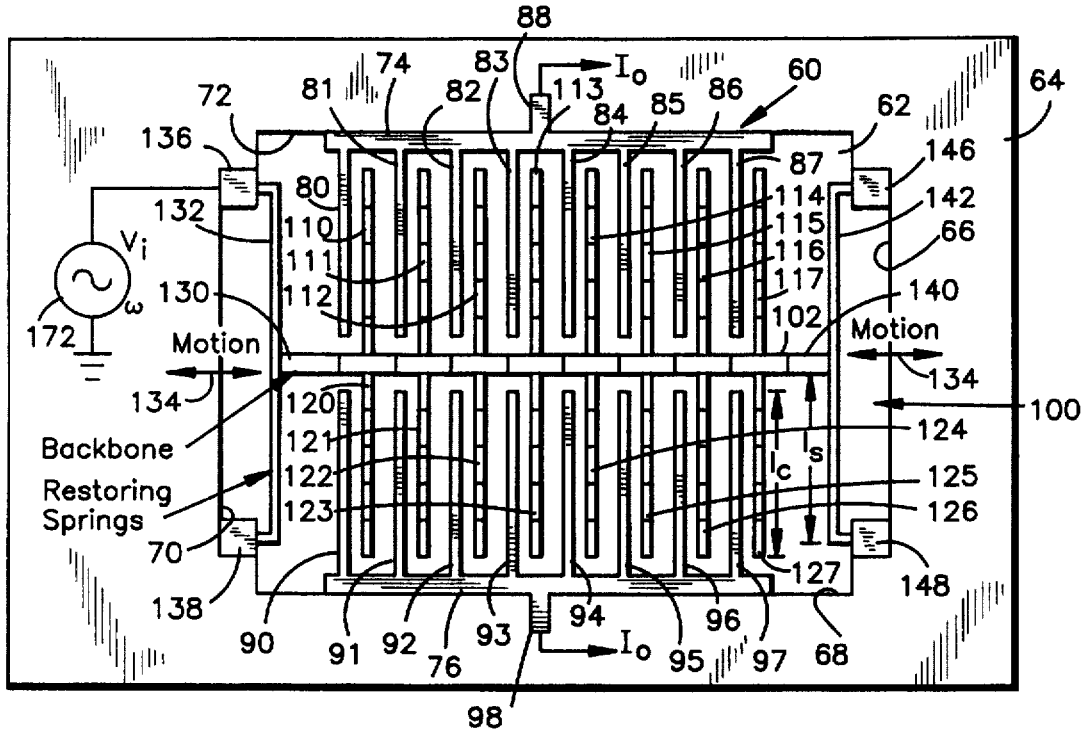

FIG. 7

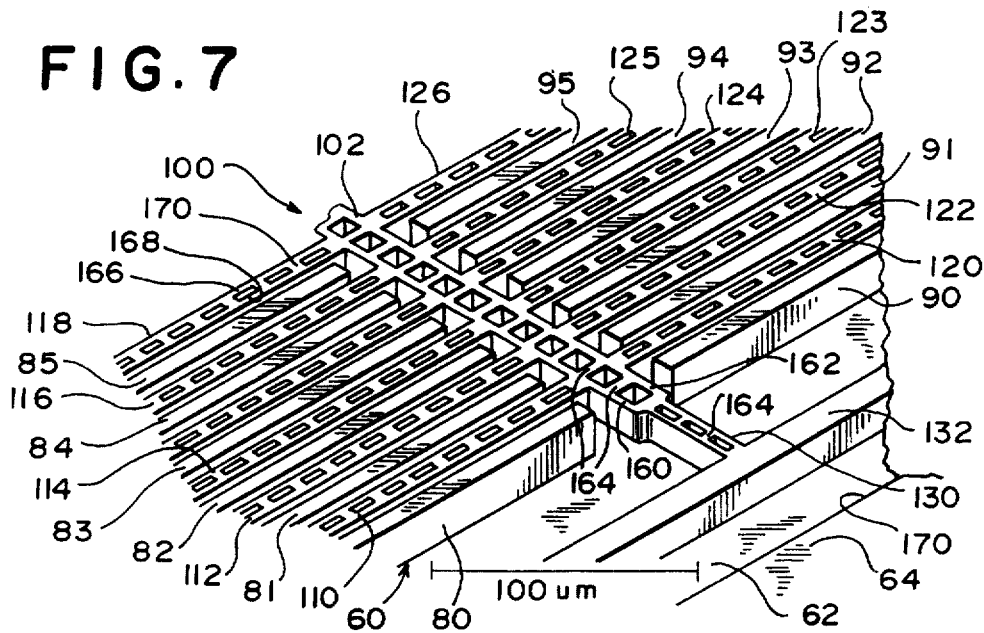

FIG. 8

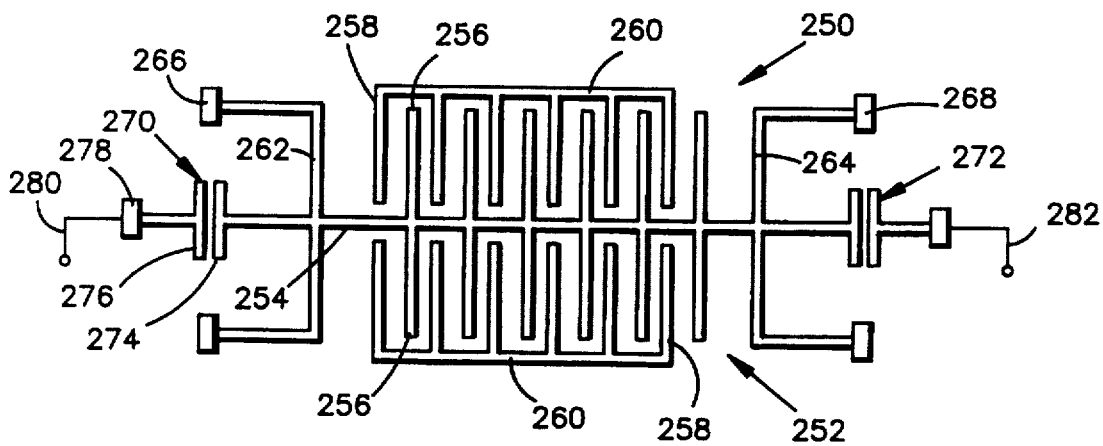
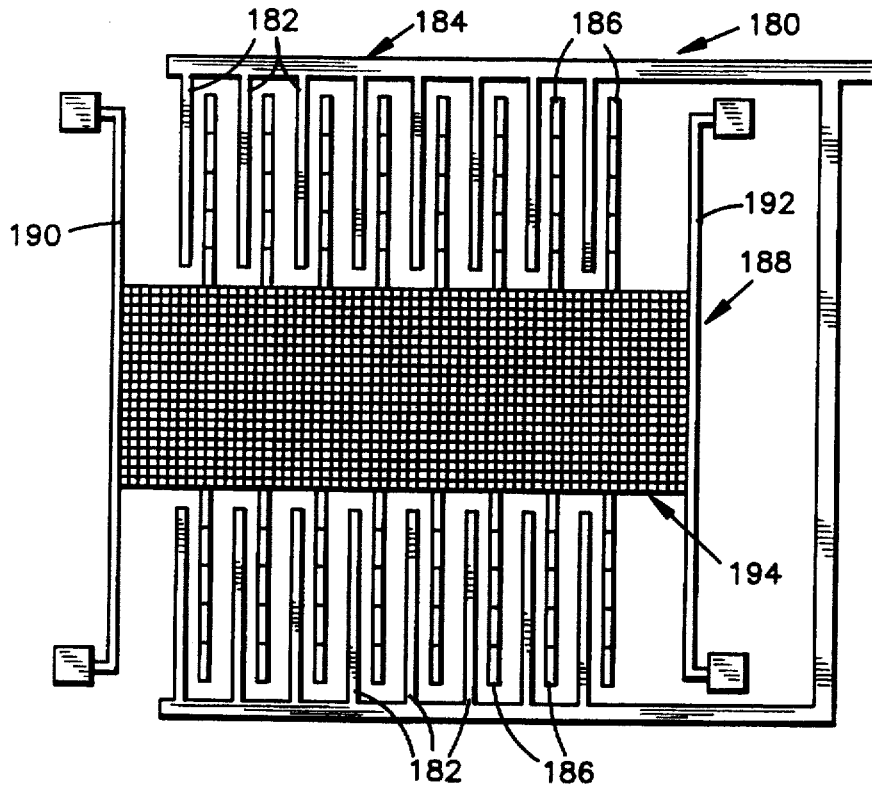

FIG. II

FIG. 10

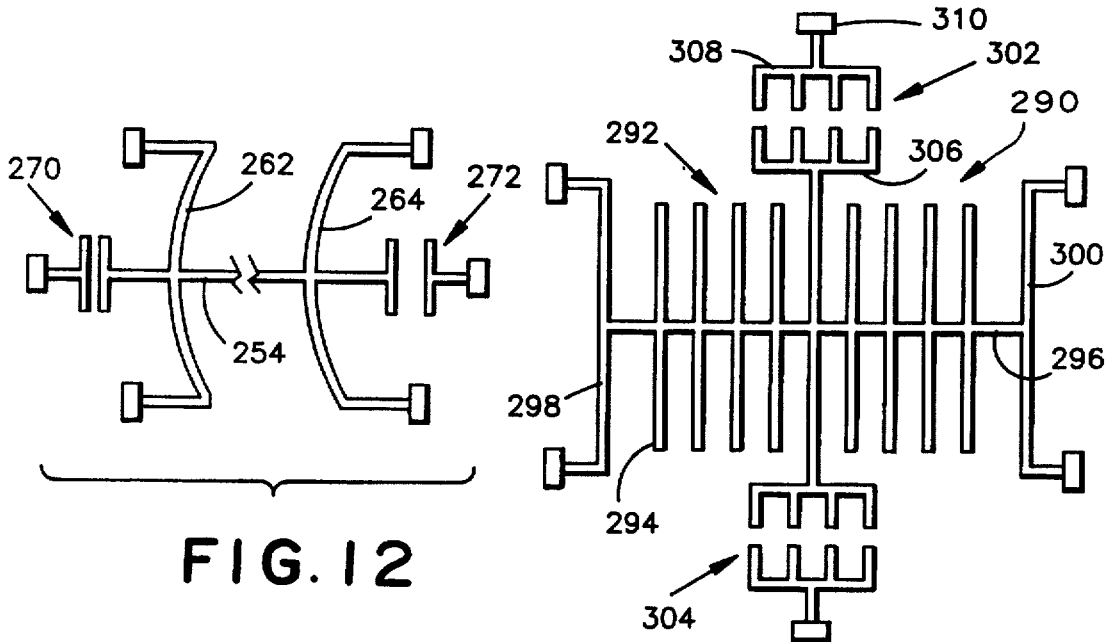
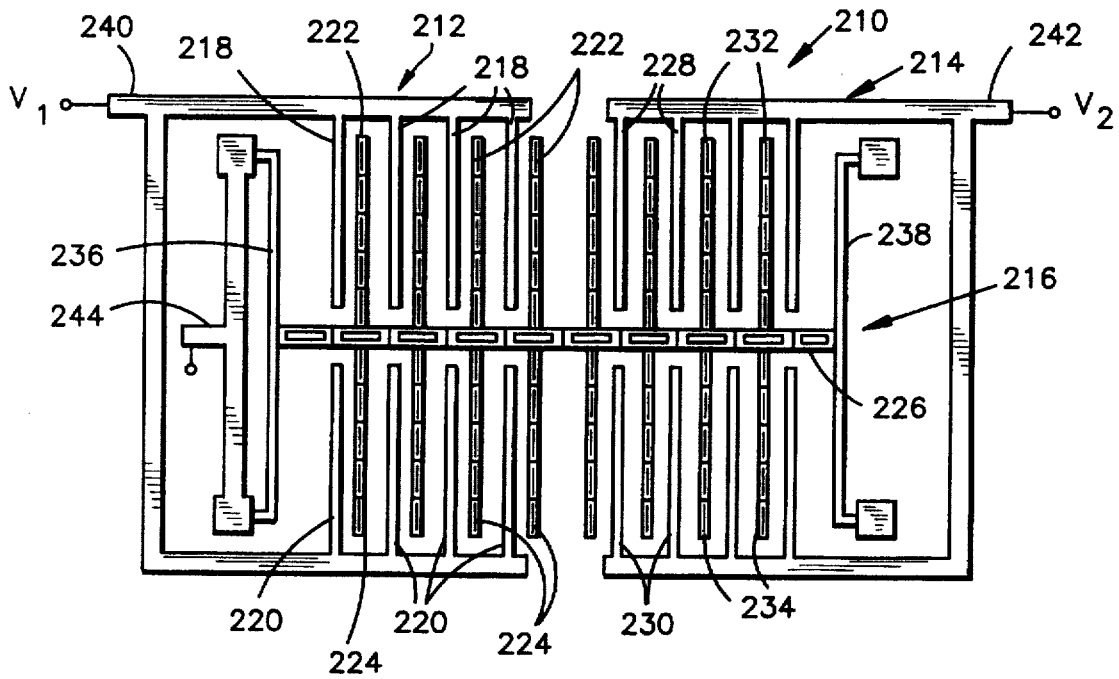

FIG. 12

FIG. 13

Explore Litigation Insights

Docket Alarm provides insights to develop a more informed litigation strategy and the peace of mind of knowing you're on top of things.

Real-Time Litigation Alerts



Keep your litigation team up-to-date with **real-time alerts** and advanced team management tools built for the enterprise, all while greatly reducing PACER spend.

Our comprehensive service means we can handle Federal, State, and Administrative courts across the country.

Advanced Docket Research



With over 230 million records, Docket Alarm's cloud-native docket research platform finds what other services can't. Coverage includes Federal, State, plus PTAB, TTAB, ITC and NLRB decisions, all in one place.

Identify arguments that have been successful in the past with full text, pinpoint searching. Link to case law cited within any court document via Fastcase.

Analytics At Your Fingertips



Learn what happened the last time a particular judge, opposing counsel or company faced cases similar to yours.

Advanced out-of-the-box PTAB and TTAB analytics are always at your fingertips.

API

Docket Alarm offers a powerful API (application programming interface) to developers that want to integrate case filings into their apps.

LAW FIRMS

Build custom dashboards for your attorneys and clients with live data direct from the court.

Automate many repetitive legal tasks like conflict checks, document management, and marketing.

FINANCIAL INSTITUTIONS

Litigation and bankruptcy checks for companies and debtors.

E-DISCOVERY AND LEGAL VENDORS

Sync your system to PACER to automate legal marketing.