



US 20050212756A1

(19) **United States**

(12) **Patent Application Publication** (10) **Pub. No.: US 2005/0212756 A1**

Marvit et al.

(43) **Pub. Date: Sep. 29, 2005**

(54) **GESTURE BASED NAVIGATION OF A HANDHELD USER INTERFACE**

(57) **ABSTRACT**

(76) Inventors: **David L. Marvit**, San Francisco, CA (US); **Albert H. M. Reinhardt**, San Francisco, CA (US); **B. Thomas Adler**, Menlo Park, CA (US); **Hitoshi Matsumoto**, San Jose, CA (US)

A motion controlled handheld device includes a display having a viewable surface and operable to generate a current image. The device includes a motion detection module operable to detect motion of the device within three dimensions and to identify components of the motion in relation to the viewable surface. The device also includes a gesture database comprising a plurality of gestures, each gesture defined by a motion of the device with respect to a first position of the device. The gestures comprise at least four planar gestures each defined by a motion vector generally aligned in parallel with the viewable surface. The device includes a gesture mapping database mapping each of the gestures to a corresponding command, the gesture mapping database mapping each of the four planar gestures to a corresponding grid navigation command. The device also includes a motion response module operable to identify a matching one of the planar gestures based on the motion and to determine the corresponding one of the grid navigation commands based on the identified planar gesture and a display control module operable to logically parse a viewable image into a plurality of grid sections, to set one of the grid sections as the current image, and to set another one of the grid sections as the current image in response to the determined grid navigation command.

Correspondence Address:
BAKER BOTTS L.L.P.
2001 ROSS AVENUE
SUITE 600
DALLAS, TX 75201-2980 (US)

(21) Appl. No.: **10/807,568**

(22) Filed: **Mar. 23, 2004**

Publication Classification

(51) **Int. Cl.⁷** **G09G 5/00; G09G 5/08**
(52) **U.S. Cl.** **345/156**

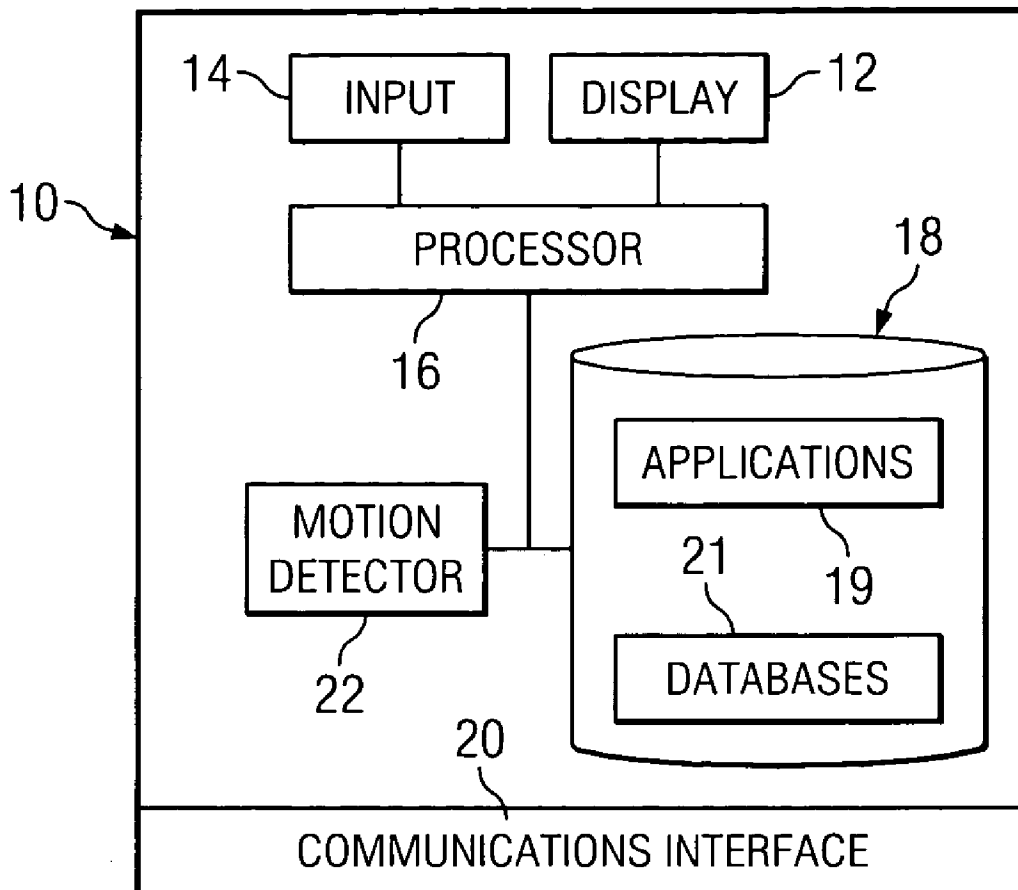

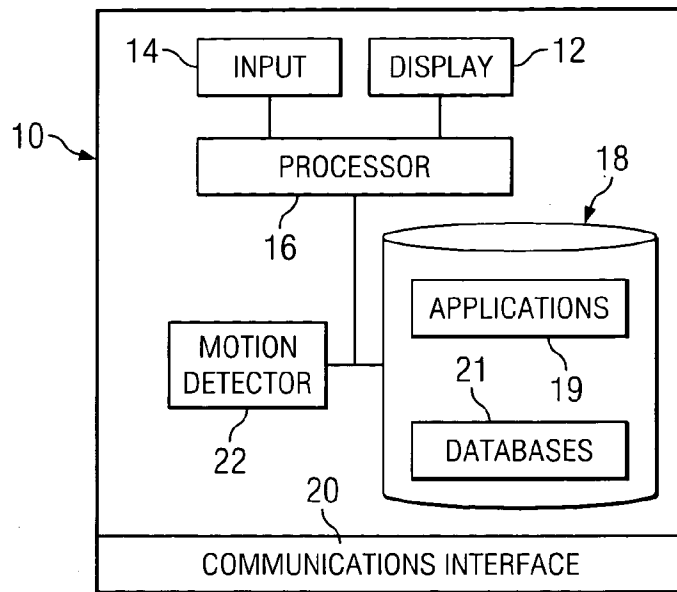

FIG. 1

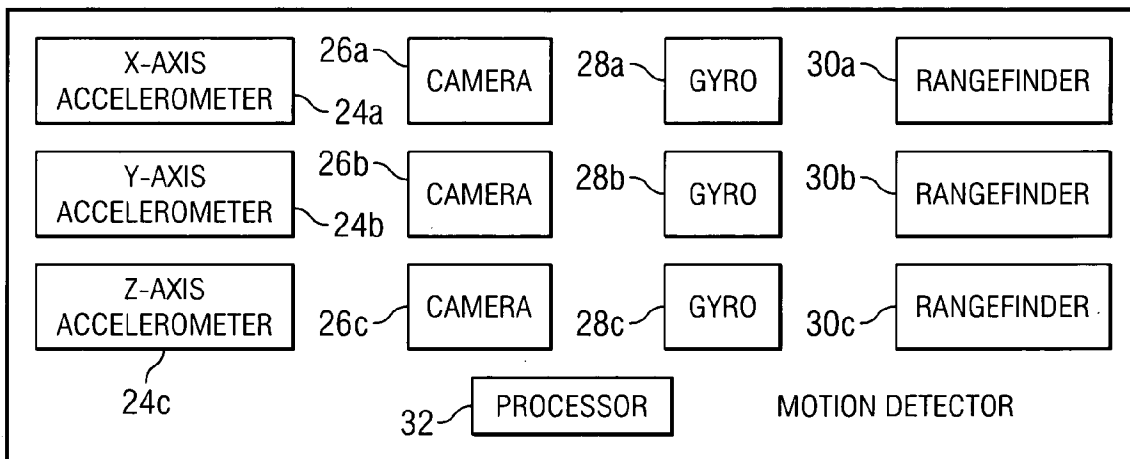

FIG. 2

22

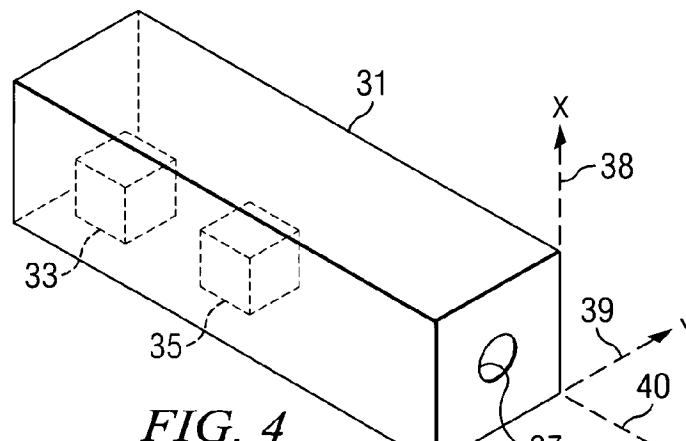

FIG. 4

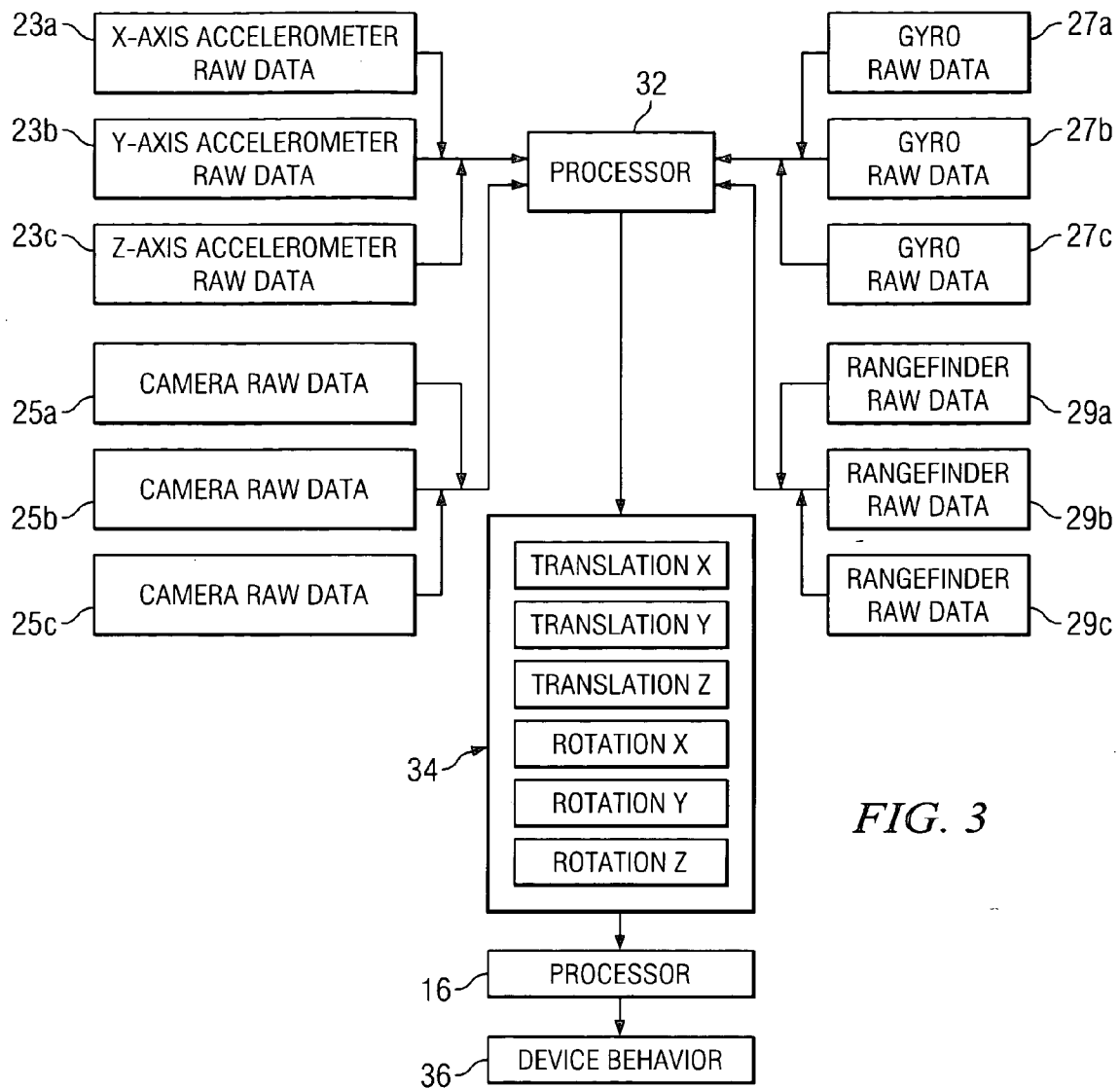

FIG. 3

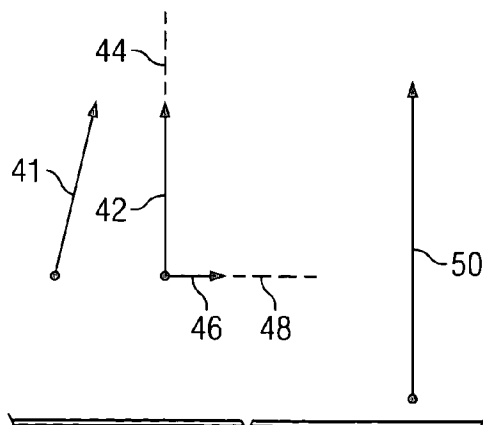

FIG. 5

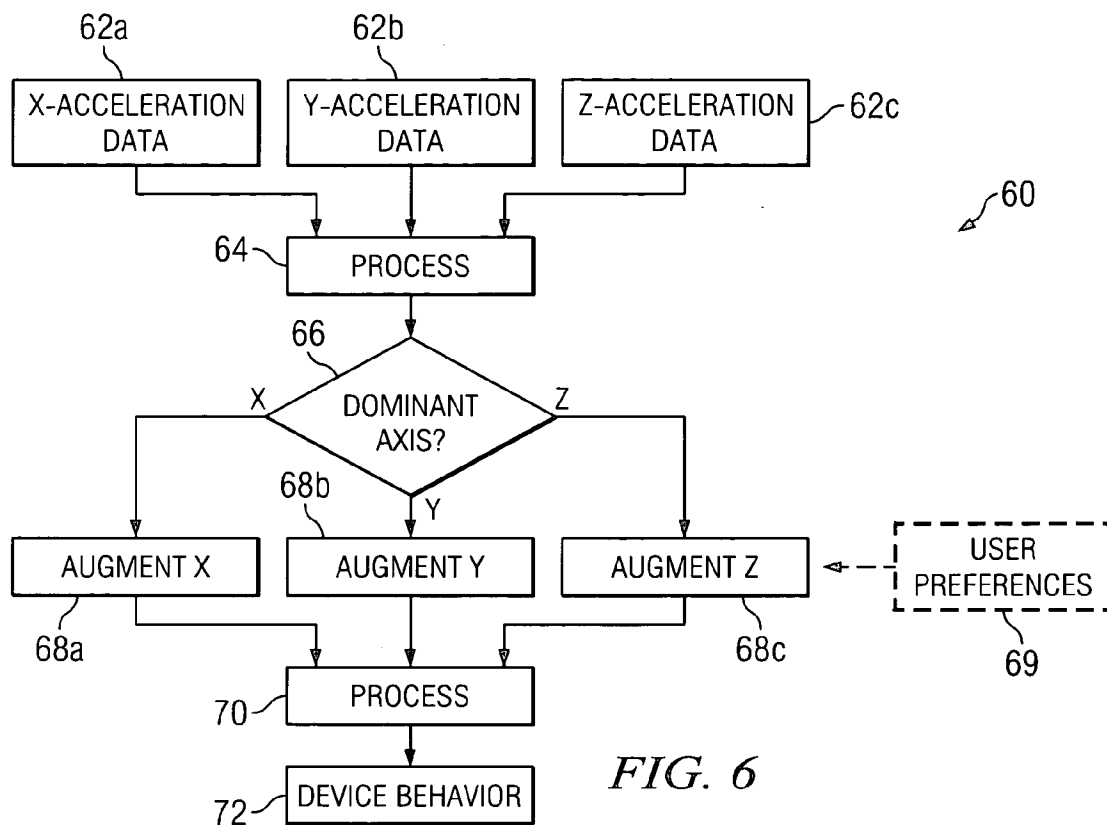

FIG. 6

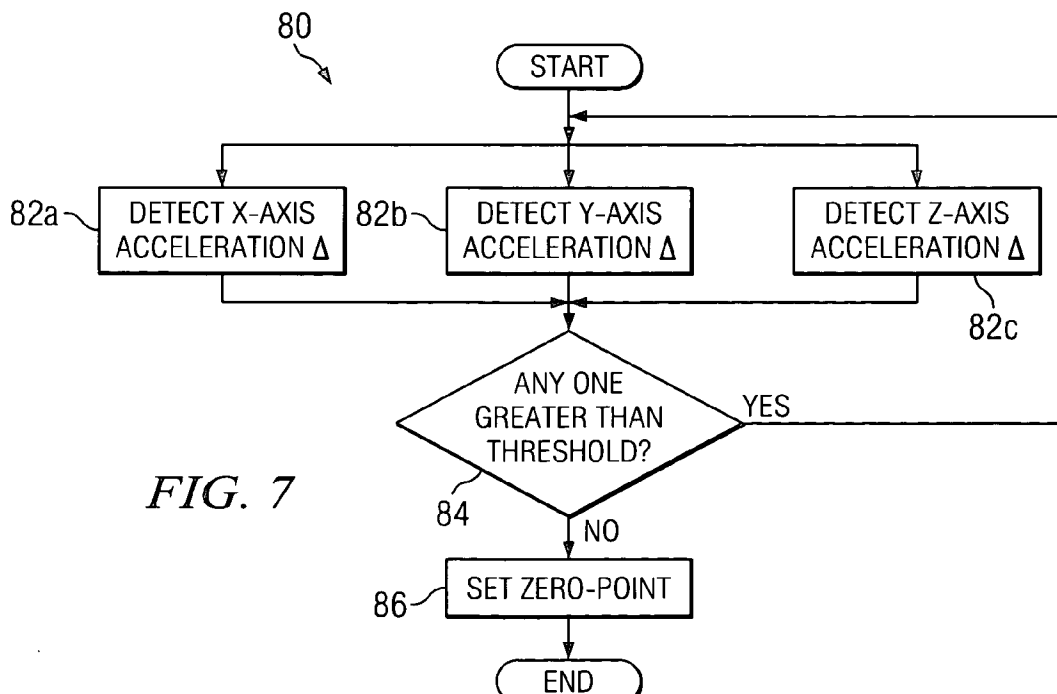

FIG. 7

FIG. 8

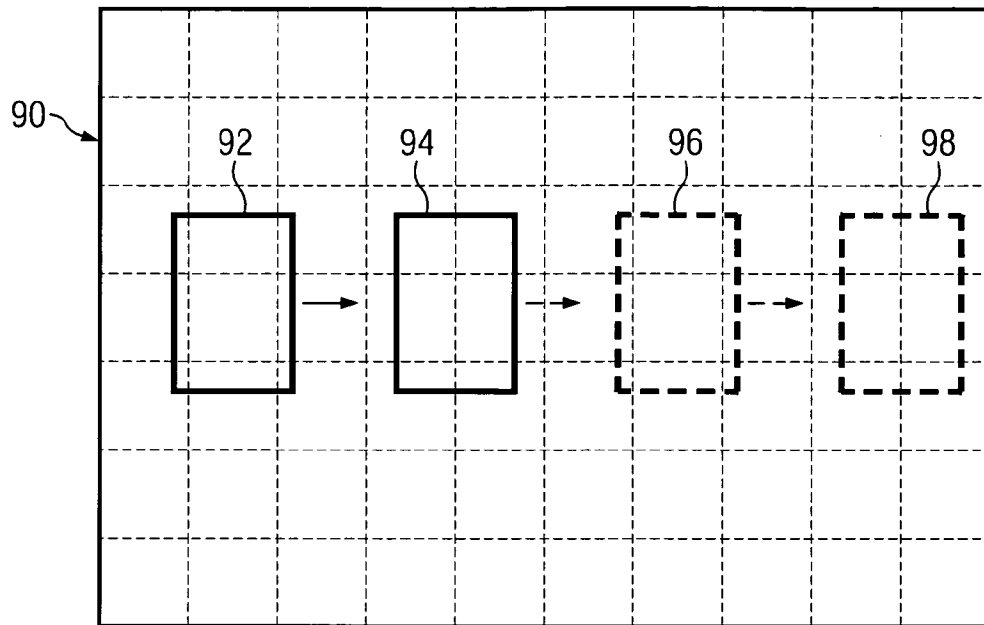
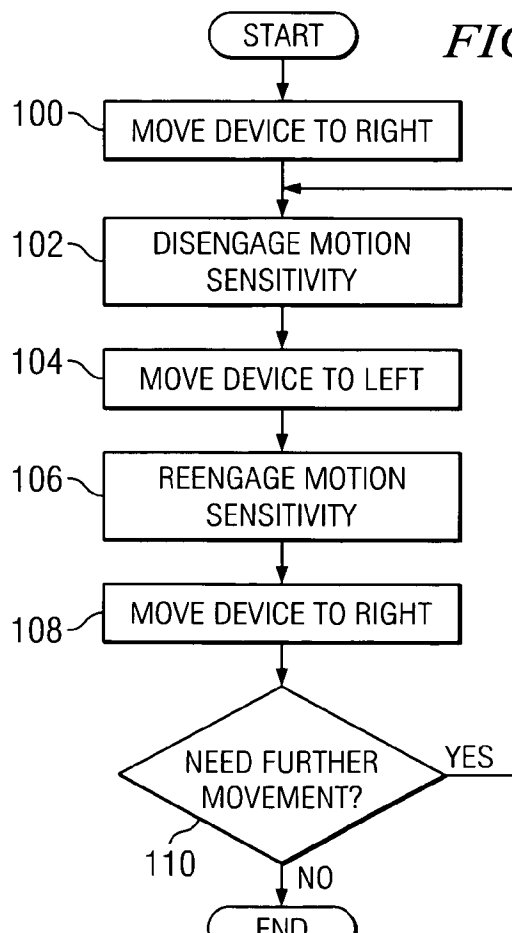

FIG. 9



Explore Litigation Insights

Docket Alarm provides insights to develop a more informed litigation strategy and the peace of mind of knowing you're on top of things.

Real-Time Litigation Alerts



Keep your litigation team up-to-date with **real-time alerts** and advanced team management tools built for the enterprise, all while greatly reducing PACER spend.

Our comprehensive service means we can handle Federal, State, and Administrative courts across the country.

Advanced Docket Research



With over 230 million records, Docket Alarm's cloud-native docket research platform finds what other services can't. Coverage includes Federal, State, plus PTAB, TTAB, ITC and NLRB decisions, all in one place.

Identify arguments that have been successful in the past with full text, pinpoint searching. Link to case law cited within any court document via Fastcase.

Analytics At Your Fingertips



Learn what happened the last time a particular judge, opposing counsel or company faced cases similar to yours.

Advanced out-of-the-box PTAB and TTAB analytics are always at your fingertips.

API

Docket Alarm offers a powerful API (application programming interface) to developers that want to integrate case filings into their apps.

LAW FIRMS

Build custom dashboards for your attorneys and clients with live data direct from the court.

Automate many repetitive legal tasks like conflict checks, document management, and marketing.

FINANCIAL INSTITUTIONS

Litigation and bankruptcy checks for companies and debtors.

E-DISCOVERY AND LEGAL VENDORS

Sync your system to PACER to automate legal marketing.