



(19) **United States**

(12) **Patent Application Publication** (10) **Pub. No.: US 2007/0177513 A1**  
**Kuokkanen** (43) **Pub. Date: Aug. 2, 2007**

(54) **METHOD, APPARATUS, COMPUTER PROGRAM PRODUCT AND ARRANGEMENT FOR TESTING RADIO NETWORK DATA CONNECTION**

**Publication Classification**

(51) **Int. Cl.**  
*H04L 12/26* (2006.01)  
*H04L 12/56* (2006.01)  
(52) **U.S. Cl.** ..... **370/241; 370/389; 370/401**

(75) **Inventor: Jari Kuokkanen, Oulu (FI)**

Correspondence Address:  
**OLIFF & BERRIDGE, PLC**  
**P.O. BOX 19928**  
**ALEXANDRIA, VA 22320 (US)**

(57) **ABSTRACT**

A method, apparatus, computer program product and arrangement for testing radio network data connections. The method comprises establishing, by means of radio network terminals, simultaneous data connections in accordance with the TCP/IP (Transmission Control Protocol/Internet Protocol) protocol or the UDP/IP (User Datagram Protocol/Internet Protocol) protocol from the host computer to at least one server connected to the radio network. This is performed by establishing beach data connection from the host computer to a different public IP (Internet Protocol) address of the server, and dynamically establishing a dedicated unambiguous route for each data connection, whereby the data connections to different IP addresses travel along different routes via different terminals and their air interfaces. Each established data connection may be measured separately.

(73) **Assignee: Nemo Technologies OY, Oulunsalo (FI)**

(21) **Appl. No.: 10/591,295**

(22) **PCT Filed: Mar. 22, 2005**

(86) **PCT No.: PCT/FI05/50100**

§ 371(c)(1),  
(2), (4) **Date: Sep. 25, 2006**

(30) **Foreign Application Priority Data**

Mar. 26, 2004 (FI)..... 20045108

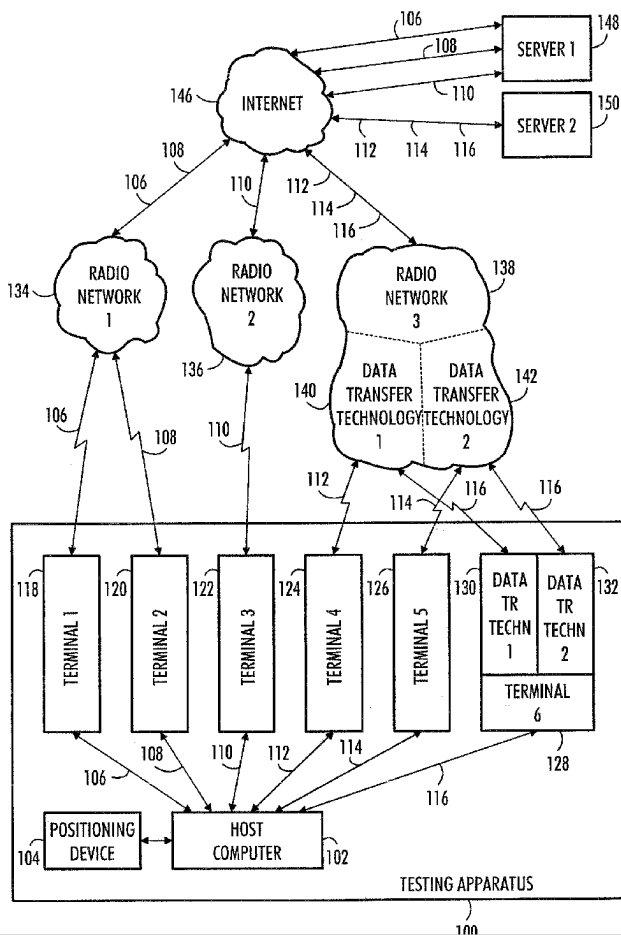

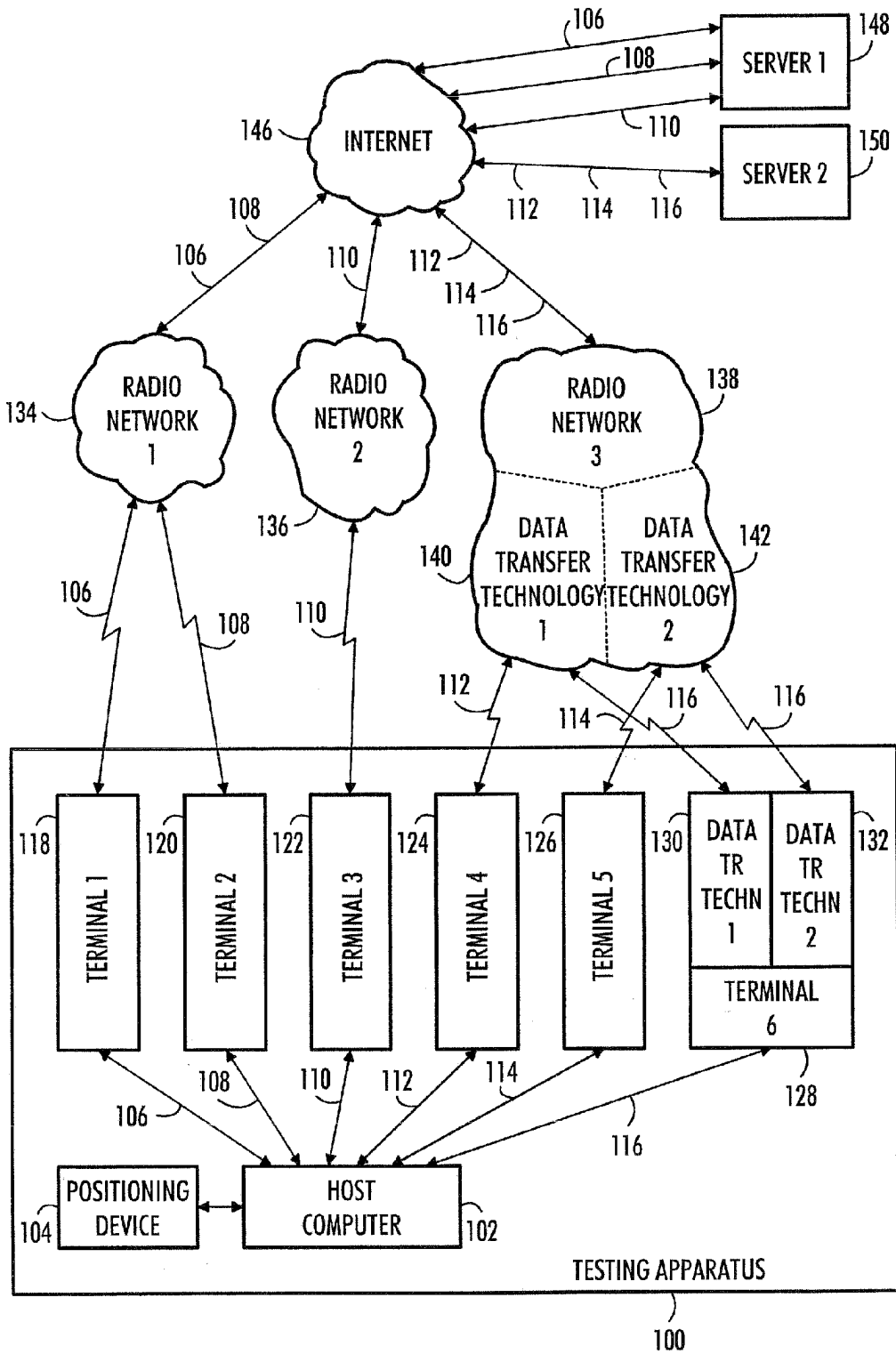

FIG. 1

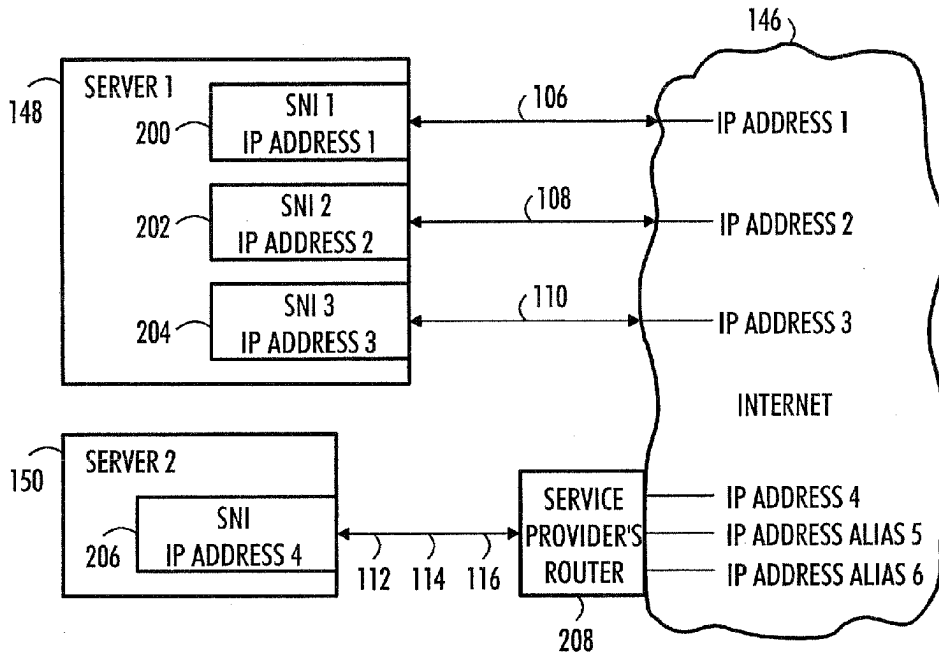

FIG. 2

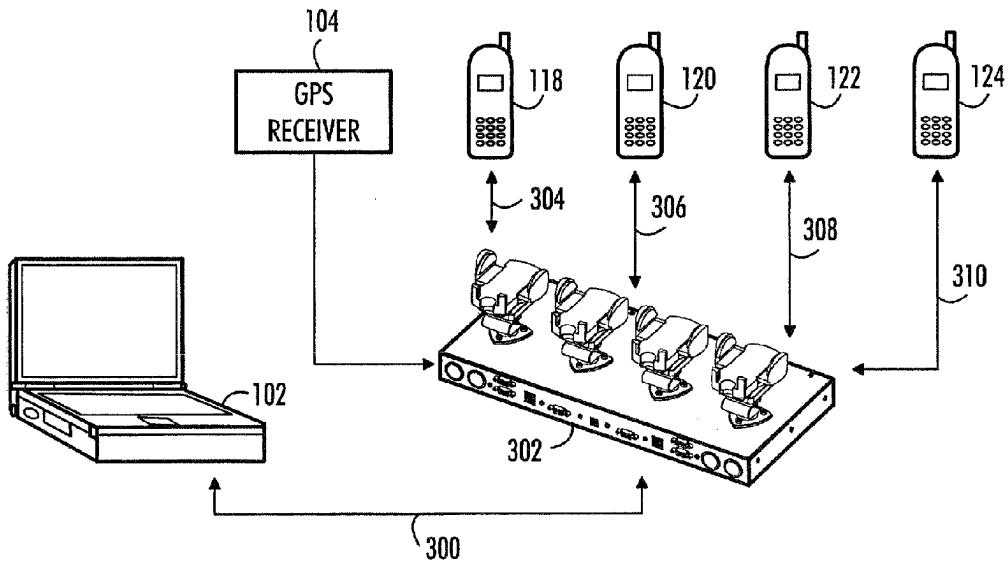

FIG. 3

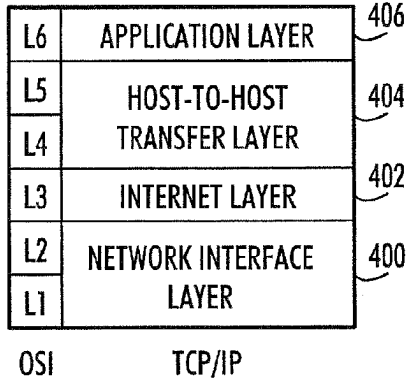

FIG. 4

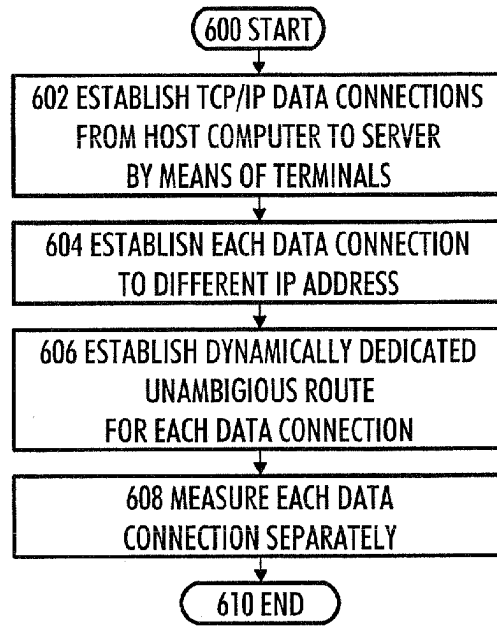

FIG. 6

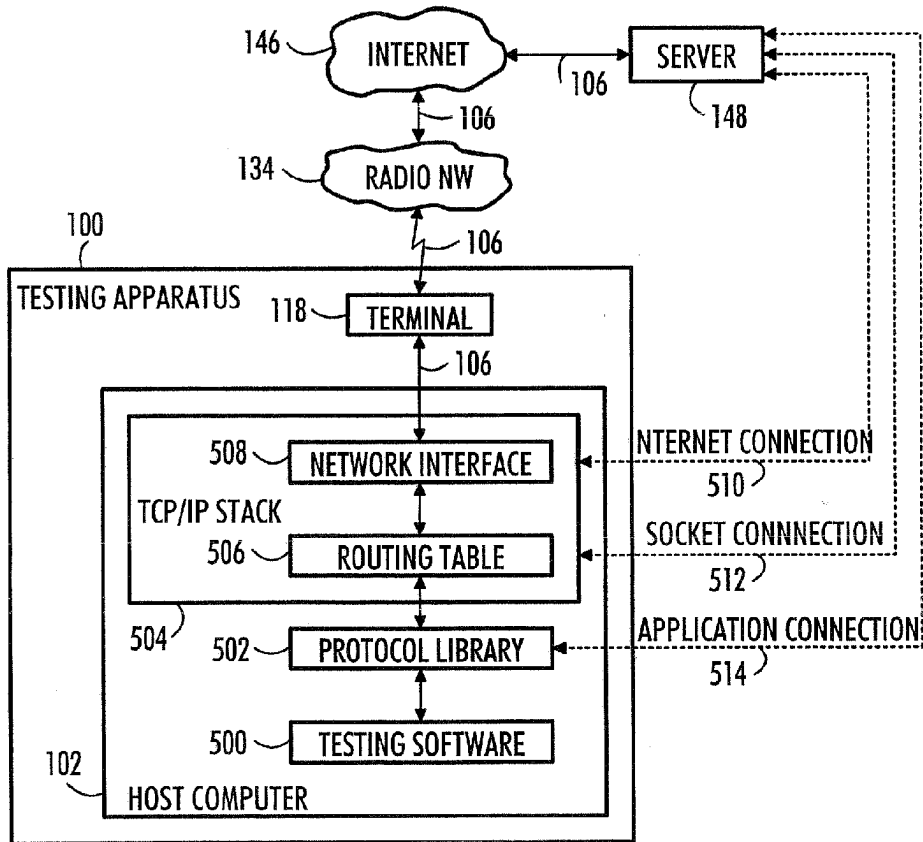

FIG. 5

```

C:\>route print
=====
Interface List
0x1.....MS TCP Loopback interface
0x18000003....00 53 45 00 00 00.....WAN (PPP/SLIP) Interface
=====
Active Routes:
Network Destination    Netmask          Gateway         Interface       Metric
0.0.0.0                0.0.0.0         10.105.136.163 10.105.136.163 1
10.105.136.163        255.255.255.255 127.0.0.1      127.0.0.1      1
10.255.255.255        255.255.255.255 10.105.136.163 10.105.136.163 1
127.0.0.0             255.0.0.0       127.0.0.1      127.0.0.1      1
192.168.254.254       255.255.255.255 10.105.136.163 10.105.136.163 1
224.0.0.0             224.0.0.0       10.105.136.163 10.105.136.163 1
Default Gateway:      10.105.136.163
=====
Persistent Routes:
None

Netmask: 255.255.224.0 11111111.11111111.11100000.00000000
AND
Destination IP: 80.223.161.25 01010000.11011111.10100001.00011001
-----
Result: 80.223.160.0 01010000.11011111.10100000.00000000

Network Destination    Netmask          Gateway         Interface       Metric
80.223.161.25        255.255.255.255 10.105.136.163 10.105.136.163 1

Netmask: 255.255.255.255 11111111.11111111.11111111.11111111
AND
Destination IP: 80.223.161.25 01010000.11011111.10100001.00011001
-----
Result: 80.223.161.25 01010000.11011111.10100001.00011001

=====
Interface List
0x1.....MS TCP Loopback interface
0x18000003....00 53 45 00 00 00.....WAN (PPP/SLIP) Interface
0x19000004....00 53 45 00 00 00.....WAN (PPP/SLIP) Interface
=====
Active Routes:
Network Destination    Netmask          Gateway         Interface       Metric
80.223.161.25        255.255.255.255 10.105.136.163 10.105.136.163 1
80.223.160.29        255.255.255.255 10.105.146.249 10.105.146.249 1
Default Gateway:      10.105.146.249
=====
Persistent Routes:
None

```

FIG. 7

# Explore Litigation Insights

Docket Alarm provides insights to develop a more informed litigation strategy and the peace of mind of knowing you're on top of things.

## Real-Time Litigation Alerts



Keep your litigation team up-to-date with **real-time alerts** and advanced team management tools built for the enterprise, all while greatly reducing PACER spend.

Our comprehensive service means we can handle Federal, State, and Administrative courts across the country.

## Advanced Docket Research



With over 230 million records, Docket Alarm's cloud-native docket research platform finds what other services can't. Coverage includes Federal, State, plus PTAB, TTAB, ITC and NLRB decisions, all in one place.

Identify arguments that have been successful in the past with full text, pinpoint searching. Link to case law cited within any court document via Fastcase.

## Analytics At Your Fingertips



Learn what happened the last time a particular judge, opposing counsel or company faced cases similar to yours.

Advanced out-of-the-box PTAB and TTAB analytics are always at your fingertips.

## API

Docket Alarm offers a powerful API (application programming interface) to developers that want to integrate case filings into their apps.

## LAW FIRMS

Build custom dashboards for your attorneys and clients with live data direct from the court.

Automate many repetitive legal tasks like conflict checks, document management, and marketing.

## FINANCIAL INSTITUTIONS

Litigation and bankruptcy checks for companies and debtors.

## E-DISCOVERY AND LEGAL VENDORS

Sync your system to PACER to automate legal marketing.