



US 20080072178A1

(19) **United States**

(12) **Patent Application Publication**  
**Budzisch et al.**

(10) **Pub. No.: US 2008/0072178 A1**

(43) **Pub. Date: Mar. 20, 2008**

(54) **GRAPHICAL USER INTERFACE (GUI) FOR DISPLAYING SOFTWARE COMPONENT AVAILABILITY AS DETERMINED BY A MESSAGING INFRASTRUCTURE**

**Publication Classification**

- (51) **Int. Cl.**  
*G06F 3/048* (2006.01)  
*G06F 15/173* (2006.01)
- (52) **U.S. Cl.** ..... 715/853; 709/223
- (57) **ABSTRACT**

(76) **Inventors:** **Janko Budzisch**, Reilingen (DE); **Pavel Kojevnikov**, Rauenberg (DE); **Stephen Pfeiffer**, Schrieshem (DE)

An IS monitoring approach is described that is capable of monitoring the availability of various software components. A further capability is that the availability of the individual software components upon which a specific business logic process depends may each be individually and continuously checked, in a combined fashion that is referenced to the specific business logic process, so that the status of the business logic process itself (e.g., operable or non-operable) can be continuously determined on an on-going basis. Moreover, operability or non-operability can be established over a wide range of different business logic processes on a process by process basis. In various embodiments, the results of the monitoring may be continuously updated and displayed in a display so that an IS administrator can visually ascertain the status of the enterprise's various business logic processes.

Correspondence Address:  
**SAP/BLAKELY**  
**1279 OAKMEAD PARKWAY**  
**SUNNYVALE, CA 94085-4040**

(21) **Appl. No.: 10/749,769**

(22) **Filed: Dec. 30, 2003**

**Related U.S. Application Data**

(60) Provisional application No. 60/513,942, filed on Oct. 24, 2003.

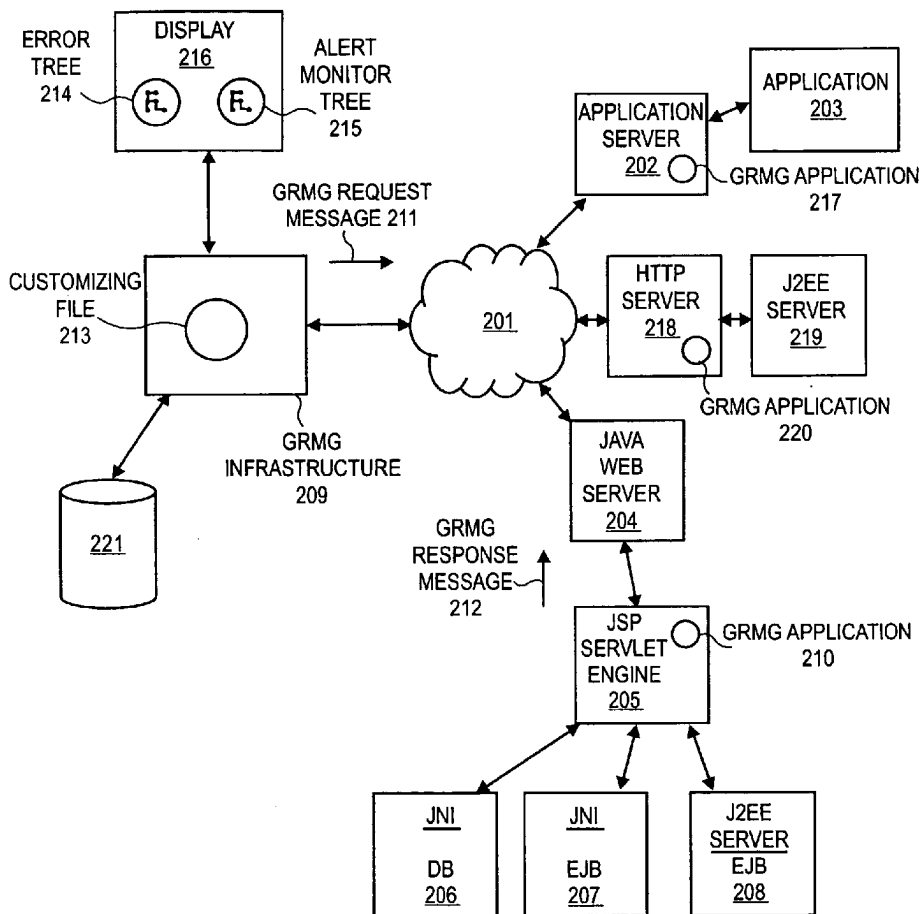

Data Co Exhibit 1028

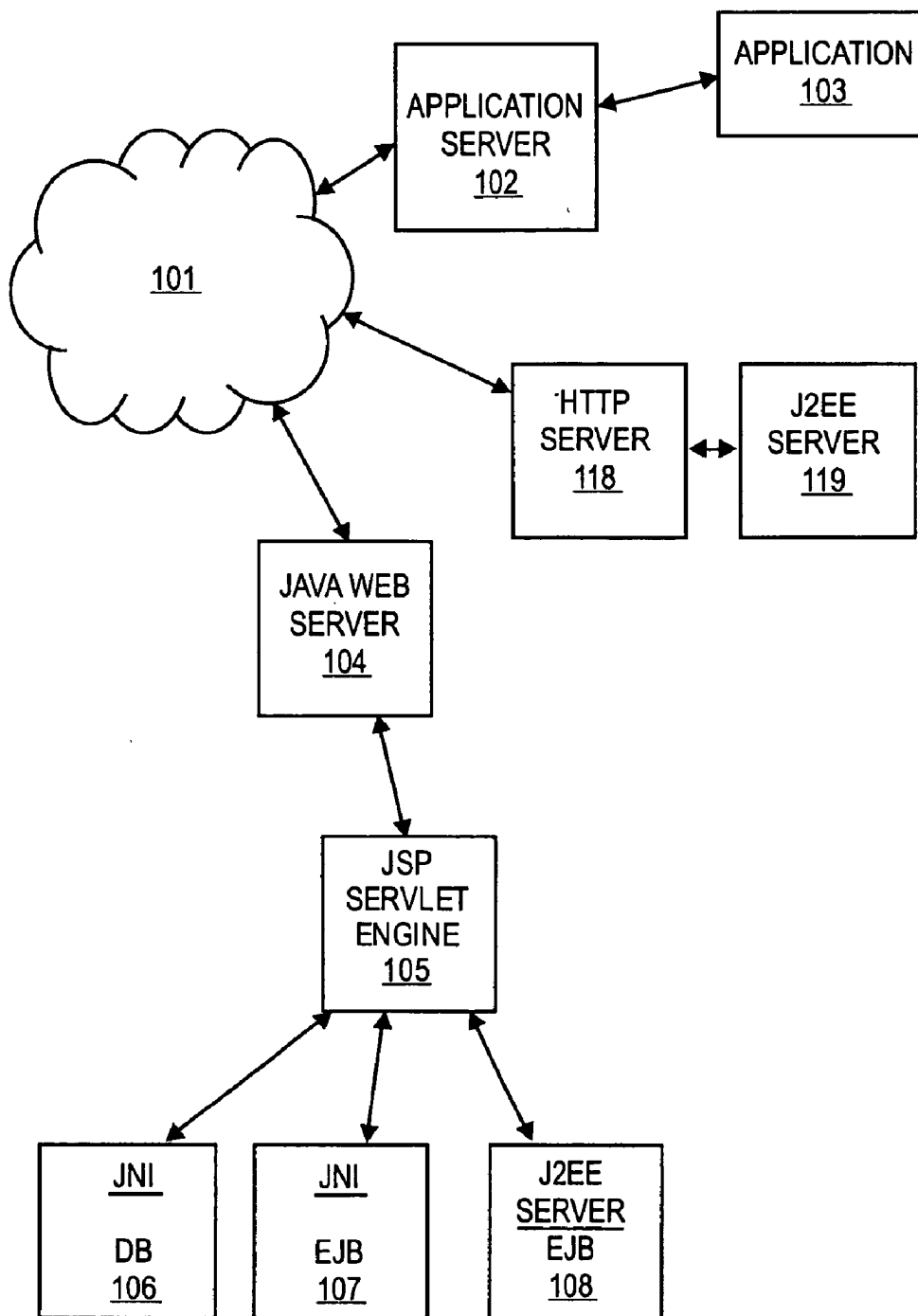

FIG. 1

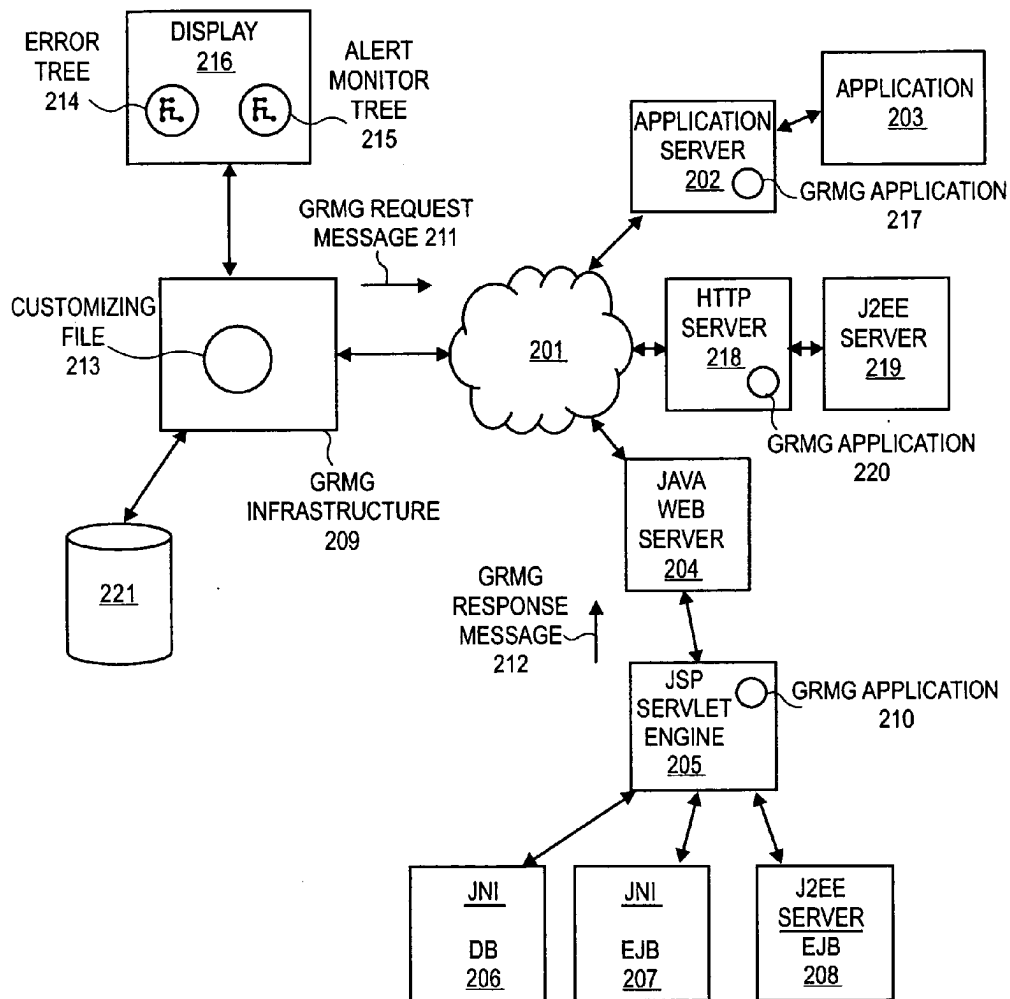

FIG. 2

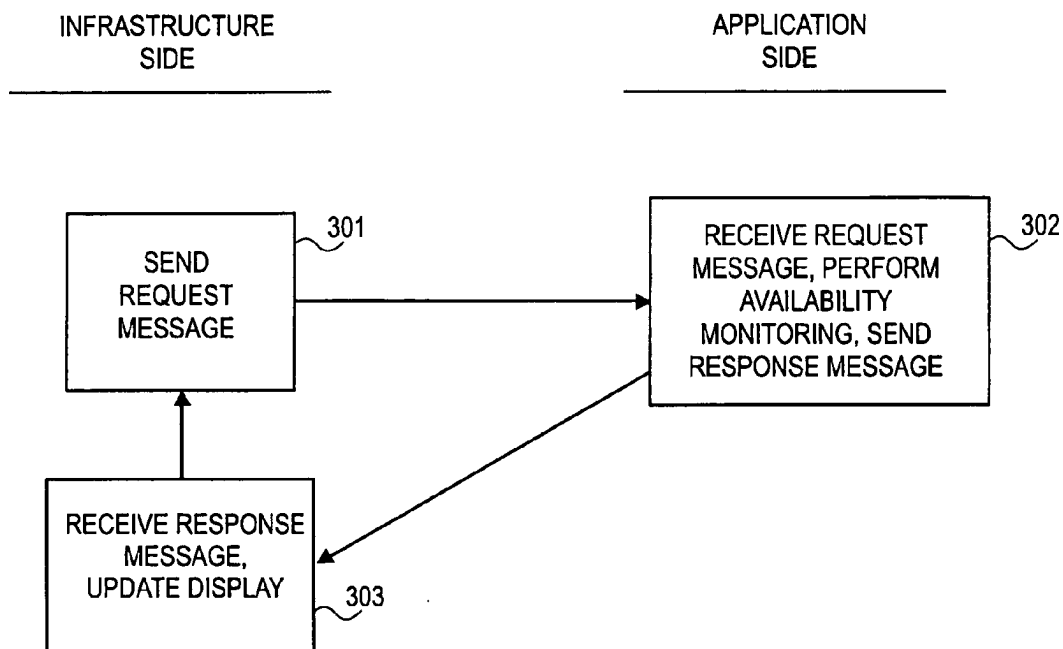

FIG. 3

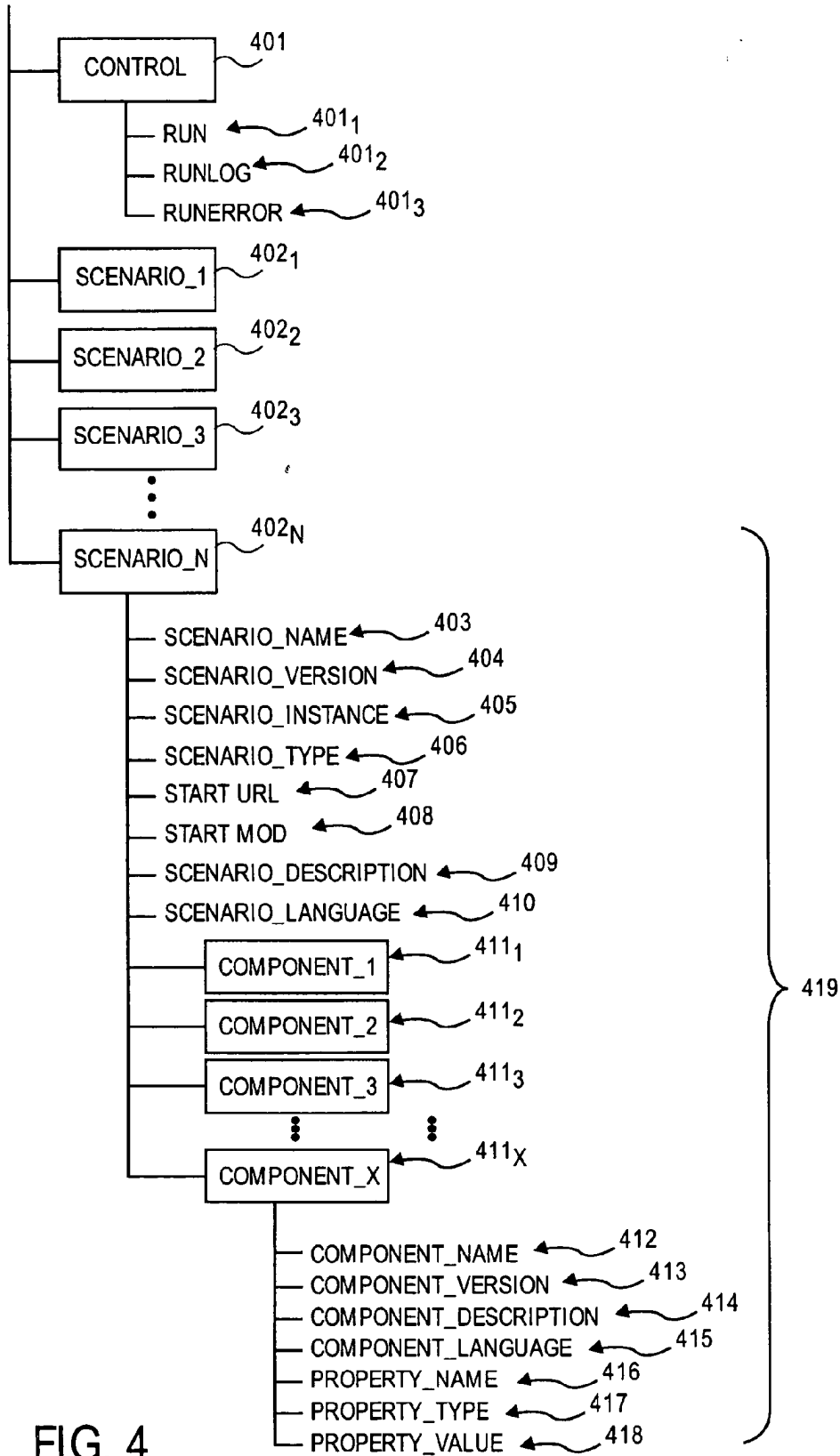

FIG. 4

# Explore Litigation Insights

Docket Alarm provides insights to develop a more informed litigation strategy and the peace of mind of knowing you're on top of things.

## Real-Time Litigation Alerts



Keep your litigation team up-to-date with **real-time alerts** and advanced team management tools built for the enterprise, all while greatly reducing PACER spend.

Our comprehensive service means we can handle Federal, State, and Administrative courts across the country.

## Advanced Docket Research



With over 230 million records, Docket Alarm's cloud-native docket research platform finds what other services can't. Coverage includes Federal, State, plus PTAB, TTAB, ITC and NLRB decisions, all in one place.

Identify arguments that have been successful in the past with full text, pinpoint searching. Link to case law cited within any court document via Fastcase.

## Analytics At Your Fingertips



Learn what happened the last time a particular judge, opposing counsel or company faced cases similar to yours.

Advanced out-of-the-box PTAB and TTAB analytics are always at your fingertips.

## API

Docket Alarm offers a powerful API (application programming interface) to developers that want to integrate case filings into their apps.

## LAW FIRMS

Build custom dashboards for your attorneys and clients with live data direct from the court.

Automate many repetitive legal tasks like conflict checks, document management, and marketing.

## FINANCIAL INSTITUTIONS

Litigation and bankruptcy checks for companies and debtors.

## E-DISCOVERY AND LEGAL VENDORS

Sync your system to PACER to automate legal marketing.