



US 20140315016A1

(19) **United States**

(12) **Patent Application Publication**
Dollase et al.

(10) **Pub. No.: US 2014/0315016 A1**

(43) **Pub. Date: Oct. 23, 2014**

(54) **ADHESIVE SUBSTANCE, IN PARTICULAR FOR ENCAPSULATING AN ELECTRONIC ASSEMBLY**

Publication Classification

(71) Applicant: **tesa SE**, Hamburg (DE)

(51) **Int. Cl.**
H01L 23/29 (2006.01)
C09J 7/02 (2006.01)
C09J 153/00 (2006.01)

(72) Inventors: **Thilo Dollase**, Hamburg (DE); **Thorsten Krawinkel**, Hamburg (DE); **Minyoung Bai**, Hamburg (DE)

(52) **U.S. Cl.**
CPC *H01L 23/293* (2013.01); *C09J 153/00* (2013.01); *C09J 7/0221* (2013.01); *C09J 2203/326* (2013.01); *C09J 2453/00* (2013.01)
USPC **428/339**; 522/109; 428/355 EP; 427/58

(21) Appl. No.: **14/351,800**

(57) **ABSTRACT**

(22) PCT Filed: **Oct. 19, 2012**

An adhesive and method for encapsulating an electronic arrangement with respect to permeants, wherein the adhesive and method have (a) at least one copolymer comprising at least isobutylene or butylene as comonomer kind and at least one comonomer kind which, considered as hypothetical homopolymer, has a softening temperature of greater than 40° C., (b) at least one kind of an at least partly hydrogenated tackifier resin, (c) at least one kind of a reactive resin based on cyclic ethers having a softening temperature of less than 40° C., preferably less than 20° C., and (d) at least one kind of a photoinitiator for initiating cationic curing

(86) PCT No.: **PCT/EP2012/070779**

§ 371 (c)(1),
(2), (4) Date: **Apr. 14, 2014**

(30) **Foreign Application Priority Data**

Oct. 21, 2011 (DE) 10 2011 085 030.9
Feb. 16, 2012 (DE) 10 2012 202 377.1

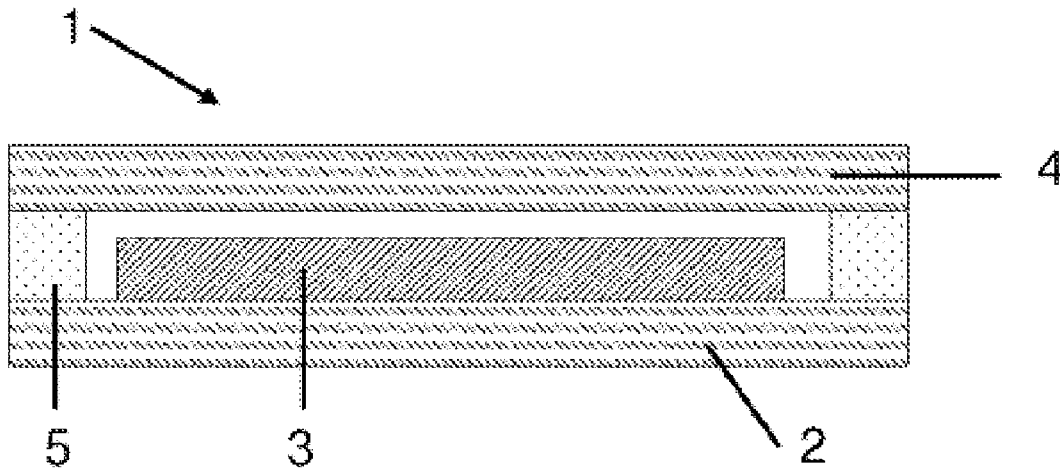

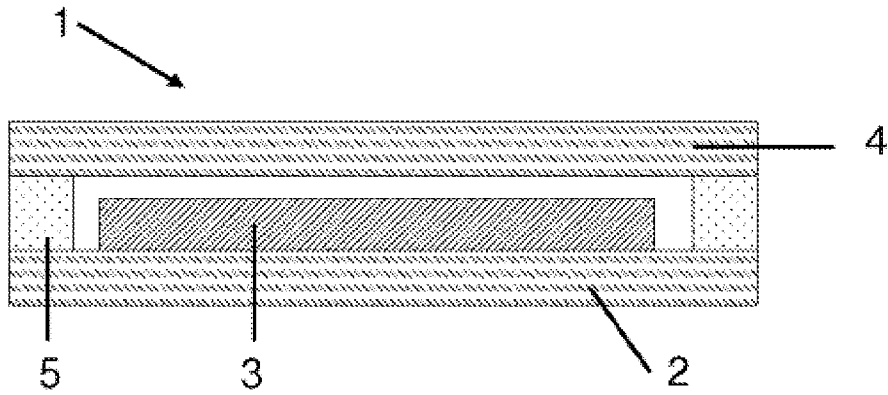

Fig. 1

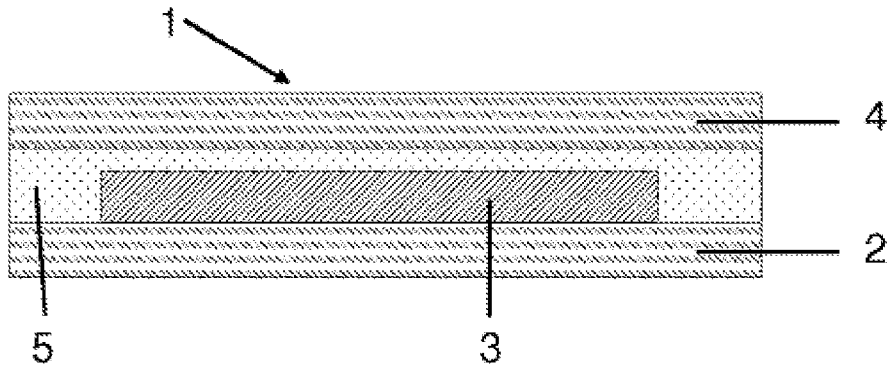

Fig. 2

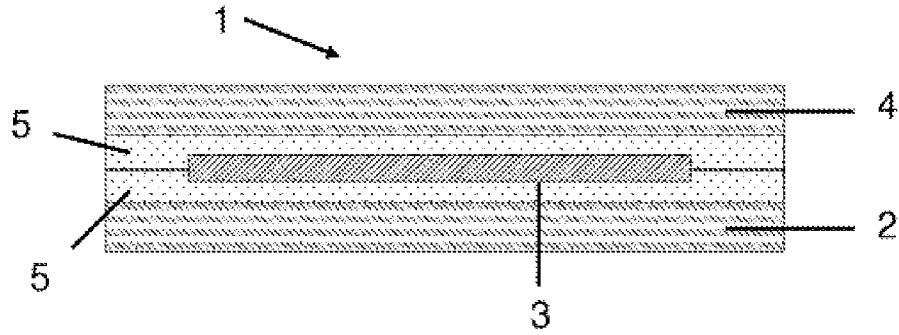

Fig. 3

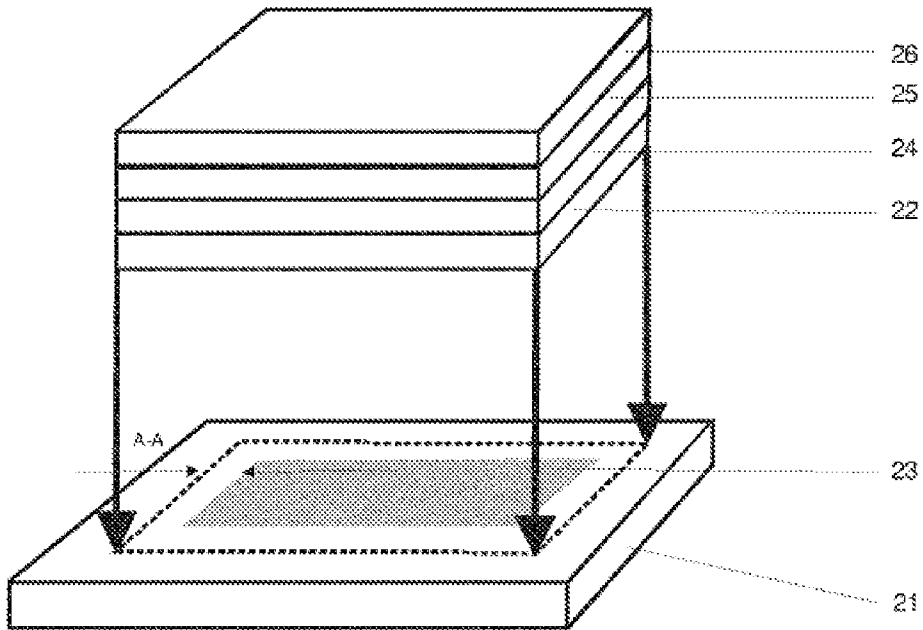

Fig. 4

**ADHESIVE SUBSTANCE, IN PARTICULAR
FOR ENCAPSULATING AN ELECTRONIC
ASSEMBLY**

[0001] The present invention relates to an adhesive particularly for encapsulating an electronic arrangement.

[0002] (Opto)electronic arrangements are being used with ever-increasing frequency in commercial products or are close to market introduction. Such arrangements comprise organic or inorganic electronic structures, examples being organic, organometallic or polymeric semiconductors or else combinations of these. Depending on the desired application, these arrangements and products are rigid or flexible in form, there being an increasing demand for flexible arrangements. Arrangements of this kind are produced, for example, by printing techniques, such as relief, gravure, screen or planographic printing, or else what is called “non-impact printing”, such as, for instance, thermal transfer printing, inkjet printing or digital printing. In many cases, however, vacuum techniques are used as well, such as chemical vapour deposition (CVD), physical vapour deposition (PVD), plasma-enhanced chemical or physical deposition techniques (PECVD), sputtering, (plasma) etching or vapour coating, with patterning taking place generally through masks.

[0003] Examples of (opto)electronic applications that are already commercial or are of interest in terms of their market potential include electrophoretic or electrochromic constructions or displays, organic or polymeric light-emitting diodes (OLEDs or PLEDs) in readout and display devices, or as illumination, electroluminescent lamps, light-emitting electrochemical cells (LEECs), organic solar cells, preferably dye or polymer solar cells, inorganic solar cells, preferably thin-film solar cells, more particularly those based on silicon, germanium, copper, indium and/or selenium, organic field-effect transistors, organic switching elements, organic optical amplifiers, organic laser diodes, organic or inorganic sensors or else organic- or inorganic-based RFID transponders.

[0004] A perceived technical challenge for realization of sufficient lifetime and function of (opto)electronic arrangements in the area of organic and/or inorganic (opto)electronics, especially in the area of organic (opto)electronics, is the protection of the components they contain against permeants. Permeants may be a large number of low molecular mass organic or inorganic compounds, more particularly water vapour and oxygen.

[0005] A large number of (opto)electronic arrangements in the area of organic and/or inorganic (opto)electronics, especially where organic raw materials are used, are sensitive not only to water vapour but also to oxygen, and for many arrangements the penetration of water vapour is classed as a relatively severe problem. During the lifetime of the electronic arrangement, therefore, it requires protection by means of encapsulation, since otherwise the performance drops off over the period of application. For example, oxidation of the components, in the case of light-emitting arrangements such as electroluminescent lamps (EL lamps) or organic light-emitting diodes (OLEDs) for instance, may drastically reduce the luminosity, the contrast in the case of electrophoretic displays (EP displays), or the efficiency in the case of solar cells, within a very short time.

[0006] In organic and/or inorganic (opto)electronics, particularly in the case of organic (opto)electronics, there is a particular need for flexible bonding solutions which consti-

ments for such (opto)electronic arrangements. The flexible bonding solutions are therefore intended not only to achieve effective adhesion between two substrates, but also, in addition, to fulfil properties such as high shear strength and peel strength, chemical stability, ageing resistance, high transparency, ease of processing, and also high flexibility and pliability.

[0007] One approach common in the prior art, therefore, is to place the electronic arrangement between two substrates that are impermeable to water vapour and oxygen. This is then followed by sealing at the edges. For non-flexible constructions, glass or metal substrates are used, which offer a high permeation barrier but are very susceptible to mechanical loads. Furthermore, these substrates give rise to a relatively high thickness of the arrangement as a whole. In the case of metal substrates, moreover, there is no transparency. For flexible arrangements, in contrast, sheetlike substrates are used, such as transparent or non-transparent films, which may have a multi-ply configuration. In this case it is possible to use not only combinations of different polymers, but also organic or inorganic layers. The use of such sheetlike substrates allows a flexible, extremely thin construction. For the different applications there are a very wide variety of possible substrates, such as films, wovens, nonwovens and papers or combinations thereof, for example.

[0008] In order to obtain the most effective sealing, specific barrier adhesives are used. A good adhesive for the sealing of (opto)electronic components has a low permeability for oxygen and particularly for water vapour, has sufficient adhesion to the arrangement, and is able to flow well onto the arrangement. Owing to incomplete wetting of the surface of the arrangement and owing to pores that remain, low capacity for flow on the arrangement may reduce the barrier effect at the interface, since it permits lateral ingress of oxygen and water vapour independently of the properties of the adhesive. Only if the contact between adhesive and substrate is continuous are the properties of the adhesive the determining factor for the barrier effect of the adhesive.

[0009] For the purpose of characterizing the barrier effect it is usual to state the oxygen transmission rate OTR and the water vapour transmission rate WVTR. Each of these rates indicates the flow of oxygen or water vapour, respectively, through a film per unit area and unit time, under specific conditions of temperature and partial pressure and also, optionally, further measurement conditions such as relative atmospheric humidity. The lower the values the more suitable the respective material for encapsulation. The statement of the permeation is not based solely on the values of WVTR or OTR, but instead also always includes an indication of the average path length of the permeation, such as the thickness of the material, for example, or a standardization to a particular path length.

[0010] The permeability P is a measure of the perviousness of a body for gases and/or liquids. A low P values denotes a good barrier effect. The permeability P is a specific value for a defined material and a defined permeant under steady-state conditions and with defined permeation path length, partial pressure and temperature. The permeability P is the product of diffusion term D and solubility term S :

$$P=D*S$$

[0011] The solubility term S describes in the present case

achieved by hydrophobic materials. The diffusion term D is a measure of the mobility of the permeant in the barrier material, and is directly dependent on properties, such as the molecular mobility or the free volume. Often, in the case of highly crosslinked or highly crystalline materials, relatively low values are obtained for D . Highly crystalline materials, however, are generally less transparent, and greater crosslinking results in a lower flexibility. The permeability P typically rises with an increase in the molecular mobility, as for instance when the temperature is raised or the glass transition point is exceeded.

[0012] A low solubility term S is usually insufficient for achieving good barrier properties. One classic example of this, in particular, are siloxane elastomers. The materials are extraordinarily hydrophobic (low solubility term), but as a result of their freely rotatable Si-O bond (large diffusion term) have a comparatively low barrier effect for water vapour and oxygen. For a good barrier effect, then, a good balance between solubility term S and diffusion term D is necessary.

[0013] Approaches at increasing the barrier effect of an adhesive must take account of the two parameters D and S , with a view in particular to their influence on the permeability of water vapour and oxygen. In addition to these chemical properties, thought must also be given to consequences of physical effects on the permeability, particularly the average permeation path length and interface properties (flow-on behaviour of the adhesive, adhesion). The ideal barrier adhesive has low D values and S values in conjunction with very good adhesion to the substrate.

[0014] For this purpose use has hitherto been made in particular of liquid adhesives and adhesives based on epoxides (WO 98/21287 A1; U.S. Pat. No. 4,051,195 A; U.S. Pat. No. 4,552,604 A). As a result of a high degree of crosslinking, these adhesives have a low diffusion term D . Their principal field of use is in the edge bonding of rigid arrangements, but also moderately flexible arrangements. Curing takes place thermally or by means of UV radiation. Full-area bonding is hard to achieve, owing to the contraction that occurs as a result of curing, since in the course of curing there are stresses between adhesive and substrate that may in turn lead to delamination.

[0015] Using these liquid adhesives harbours a series of disadvantages. For instance, low molecular mass constituents (VOCs—volatile organic compounds) may damage the sensitive electronic structures in the arrangement and may hinder production operations. The adhesive must be applied, laboriously, to each individual constituent of the arrangement. The acquisition of expensive dispensers and fixing devices is necessary in order to ensure precise positioning. Moreover, the nature of application prevents a rapid continuous operation, and the laminating step that is subsequently needed may also make it more difficult, owing to the low viscosity, to achieve a defined layer thickness and bond width within narrow limits.

[0016] Furthermore, the residual flexibility of such highly crosslinked adhesives after curing is low. In the low temperature range or in the case of 2-component systems, the use of thermally crosslinking systems is limited by the potlife, in other words the processing life until gelling has taken place. In the high temperature range, and particularly in the case of long reaction times, in turn, the sensitive (opto)electronic

(opto)electronic structures are often $60^{\circ}\text{C}.$, since above even this temperature there may be initial damage. Flexible arrangements which comprise organic electronics and are encapsulated using transparent polymer films or assemblies of polymer films and inorganic layers, in particular, have narrow limits here. The same applies to laminating steps under high pressure. In order to achieve improved durability, it is advantageous here to forgo a temperature loading step and to carry out lamination under a relatively low pressure.

[0017] As an alternative to the thermally curable liquid adhesives, radiation-curing adhesives as well are now used in many cases (US 2004/0225025 A1). The use of radiation-curing adhesives prevents long-lasting thermal load on the electronic arrangement.

[0018] Particularly if the (opto)electronic arrangements are to be flexible, it is important that the adhesive used is not too rigid and brittle. Accordingly, pressure-sensitive adhesives (PSAs) and heat-activatedly bondable adhesive sheets are particularly suitable for such bonding. In order to flow well onto the substrate but at the same time to attain a high bonding strength, the adhesives ought initially to be very soft, but then to be able to be crosslinked. As crosslinking mechanisms it is possible, depending on the chemical basis of the adhesive, to implement thermal cures and/or radiation cures. While thermal curing is very slow, radiation cures can be initiated within a few seconds. Accordingly, radiation cures, more particularly UV curing, are preferred, especially in the case of continuous production processes.

[0019] DE 10 2008 060 113 A1 describes a method for encapsulating an electronic arrangement with respect to permeants, using a PSA based on butylene block copolymers, more particularly isobutylene block copolymers, and describes the use of such an adhesive in an encapsulation method. In combination with the elastomers, defined resins, characterized by DACP and MMAP values, are preferred. The adhesive, moreover, is preferably transparent and may exhibit UV-blocking properties. As barrier properties, the adhesive preferably has a WVTR of $<40\text{ g/m}^2\text{d}$ and an OTR of $<5000\text{ g/m}^2\text{d bar}$. In the method, the PSA may be heated during and/or after application. The PSA may be crosslinked—by radiation, for example. Classes of substance are proposed via which such crosslinking can be advantageously performed. However, no specific examples are given that lead to particularly low volume permeation and interfacial permeation in conjunction with high transparency and flexibility.

[0020] EP 1 518 912 A1 teaches an adhesive for encapsulating an electroluminescent element which comprises a photocationically curable compound and a photocationic initiator. Curing takes place as a dark reaction following light stimulation. The adhesive is preferably epoxy-based. Aliphatic hydroxides and polyethers may be added as co-crosslinking components. Moreover, a tackifier resin may be present in order to adjust adhesion and cohesion. This may also include polyisobutylene. No specific information is given regarding the compatibility of the individual constituents, and there are also no indications of the molar masses of the polymers.

[0021] JP 4,475,084 B1 teaches transparent sealants for organic electroluminescent elements, that may be based on block copolymer. Examples listed are SIS and SBS and also

Explore Litigation Insights

Docket Alarm provides insights to develop a more informed litigation strategy and the peace of mind of knowing you're on top of things.

Real-Time Litigation Alerts



Keep your litigation team up-to-date with **real-time alerts** and advanced team management tools built for the enterprise, all while greatly reducing PACER spend.

Our comprehensive service means we can handle Federal, State, and Administrative courts across the country.

Advanced Docket Research



With over 230 million records, Docket Alarm's cloud-native docket research platform finds what other services can't. Coverage includes Federal, State, plus PTAB, TTAB, ITC and NLRB decisions, all in one place.

Identify arguments that have been successful in the past with full text, pinpoint searching. Link to case law cited within any court document via Fastcase.

Analytics At Your Fingertips



Learn what happened the last time a particular judge, opposing counsel or company faced cases similar to yours.

Advanced out-of-the-box PTAB and TTAB analytics are always at your fingertips.

API

Docket Alarm offers a powerful API (application programming interface) to developers that want to integrate case filings into their apps.

LAW FIRMS

Build custom dashboards for your attorneys and clients with live data direct from the court.

Automate many repetitive legal tasks like conflict checks, document management, and marketing.

FINANCIAL INSTITUTIONS

Litigation and bankruptcy checks for companies and debtors.

E-DISCOVERY AND LEGAL VENDORS

Sync your system to PACER to automate legal marketing.