

AO 120 (Rev. 08/10)

TO: Mail Stop 8 Director of the U.S. Patent and Trademark Office P.O. Box 1450 Alexandria, VA 22313-1450	REPORT ON THE FILING OR DETERMINATION OF AN ACTION REGARDING A PATENT OR TRADEMARK
-----------------------------------------------------------------------------------------------------------------------------------------------	-------------------------------------------------------------------------------------------------------------------------

In Compliance with 35 U.S.C. § 290 and/or 15 U.S.C. § 1116 you are hereby advised that a court action has been filed in the U.S. District Court Western District of Texas on the following

Trademarks or Patents. (the patent action involves 35 U.S.C. § 292.);

DOCKET NO. 6:21-cv-00454-ADA	DATE FILED 4/30/2021	U.S. DISTRICT COURT Western District of Texas
PLAINTIFF SCRAMOGE TECHNOLOGY LIMITED		DEFENDANT SAMSUNG ELECTRONICSCO., LTD.; and SAMSUNG ELECTRONICS AMERICA, INC.
PATENT OR TRADEMARK NO.	DATE OF PATENT OR TRADEMARK	HOLDER OF PATENT OR TRADEMARK
1 9,553,476	1/24/2017	Scramoge Technology Limited
2 9,825,482	11/21/2017	Scramoge Technology Limited
3 9,997,962	6/12/2018	Scramoge Technology Limited
4		
5		

In the above—entitled case, the following patent(s)/ trademark(s) have been included:

DATE INCLUDED 6/22/2021	INCLUDED BY <input checked="" type="checkbox"/> Amendment <input type="checkbox"/> Answer <input type="checkbox"/> Cross Bill <input type="checkbox"/> Other Pleading	
PATENT OR TRADEMARK NO.	DATE OF PATENT OR TRADEMARK	HOLDER OF PATENT OR TRADEMARK
1 9,843,215	12/12/2017	Scramoge Technology Limited
2 10,367,370	7/30/2019	Scramoge Technology Limited
3 10,424,941	9/24/2019	Scramoge Technology Limited
4		
5		

In the above—entitled case, the following decision has been rendered or judgement issued:

DECISION/JUDGEMENT

CLERK	(BY) DEPUTY CLERK	DATE
-------	-------------------	------

Copy 1—Upon initiation of action, mail this copy to Director Copy 3—Upon termination of action, mail this copy to Director
 Copy 2—Upon filing document adding patent(s), mail this copy to Director Copy 4—Case file copy



AO 120 (Rev. 08/10)

TO: Mail Stop 8 Director of the U.S. Patent and Trademark Office P.O. Box 1450 Alexandria, VA 22313-1450	REPORT ON THE FILING OR DETERMINATION OF AN ACTION REGARDING A PATENT OR TRADEMARK
-----------------------------------------------------------------------------------------------------------------------------------------------	-------------------------------------------------------------------------------------------------------------------------

In Compliance with 35 U.S.C. § 290 and/or 15 U.S.C. § 1116 you are hereby advised that a court action has been filed in the U.S. District Court Western District of Texas on the following

Trademarks or Patents. (the patent action involves 35 U.S.C. § 292.);

DOCKET NO. 6:21-cv-00616	DATE FILED 6/15/2021	U.S. DISTRICT COURT Western District of Texas
PLAINTIFF SCRAMOGE TECHNOLOGY LIMITED		DEFENDANT GOOGLE LLC
PATENT OR TRADEMARK NO.	DATE OF PATENT OR TRADEMARK	HOLDER OF PATENT OR TRADEMARK
1 9,843,215	12/12/2017	Scramoge Technology Limited
2 10,367,370	7/30/2019	Scramoge Technology Limited
3 10,804,740	10/13/2020	Scramoge Technology Limited
4 9,997,962	6/12/2018	Scramoge Technology Limited
5		

In the above—entitled case, the following patent(s)/ trademark(s) have been included:

DATE INCLUDED	INCLUDED BY <input type="checkbox"/> Amendment <input type="checkbox"/> Answer <input type="checkbox"/> Cross Bill <input type="checkbox"/> Other Pleading	
PATENT OR TRADEMARK NO.	DATE OF PATENT OR TRADEMARK	HOLDER OF PATENT OR TRADEMARK
1		
2		
3		
4		
5		

In the above—entitled case, the following decision has been rendered or judgement issued:

DECISION/JUDGEMENT

CLERK	(BY) DEPUTY CLERK	DATE
-------	-------------------	------

Copy 1—Upon initiation of action, mail this copy to Director Copy 3—Upon termination of action, mail this copy to Director
 Copy 2—Upon filing document adding patent(s), mail this copy to Director Copy 4—Case file copy





UNITED STATES PATENT AND TRADEMARK OFFICE

UNITED STATES DEPARTMENT OF COMMERCE
United States Patent and Trademark Office
Address: COMMISSIONER FOR PATENTS
P.O. Box 1450
Alexandria, Virginia 22313-1450
www.uspto.gov

APPLICATION NUMBER	FILING OR 371(C) DATE	FIRST NAMED APPLICANT	ATTY. DOCKET NO./TITLE
14/901,426	12/28/2015	Seok BAE	0106.001POA1

CONFIRMATION NO. 5436

POA ACCEPTANCE LETTER

151145
Shami Messinger PLLC
1000 Wisconsin Ave. NW
Suite 200
Washington, DC 20007



Date Mailed: 05/05/2021

NOTICE OF ACCEPTANCE OF POWER OF ATTORNEY

This is in response to the Power of Attorney filed 04/29/2021.

The Power of Attorney in this application is accepted. Correspondence in this application will be mailed to the above address as provided by 37 CFR 1.33.

Questions about the contents of this notice and the requirements it sets forth should be directed to the Office of Data Management, Application Assistance Unit, at (571) 272-4000 or (571) 272-4200 or 1-888-786-0101.

/agizaw/



UNITED STATES PATENT AND TRADEMARK OFFICE

UNITED STATES DEPARTMENT OF COMMERCE
United States Patent and Trademark Office
Address: COMMISSIONER FOR PATENTS
P.O. Box 1450
Alexandria, Virginia 22313-1450
www.uspto.gov

APPLICATION NUMBER	FILING OR 371(C) DATE	FIRST NAMED APPLICANT	ATTY. DOCKET NO./TITLE
14/901,426	12/28/2015	Seok BAE	DANA-0049

CONFIRMATION NO. 5436

POWER OF ATTORNEY NOTICE

34610
KED & ASSOCIATES, LLP
P.O. Box 8638
Reston, VA 20195



Date Mailed: 05/05/2021

NOTICE REGARDING CHANGE OF POWER OF ATTORNEY

This is in response to the Power of Attorney filed 04/29/2021.

- The Power of Attorney to you in this application has been revoked by the assignee who has intervenered as provided by 37 CFR 3.71. Future correspondence will be mailed to the new address of record(37 CFR 1.33).

Questions about the contents of this notice and the requirements it sets forth should be directed to the Office of Data Management, Application Assistance Unit, at (571) 272-4000 or (571) 272-4200 or 1-888-786-0101.

/agizaw/

AO 120 (Rev. 08/10)

TO: Mail Stop 8 Director of the U.S. Patent and Trademark Office P.O. Box 1450 Alexandria, VA 22313-1450	REPORT ON THE FILING OR DETERMINATION OF AN ACTION REGARDING A PATENT OR TRADEMARK
-----------------------------------------------------------------------------------------------------------------------------------------------	-------------------------------------------------------------------------------------------------------------------------

In Compliance with 35 U.S.C. § 290 and/or 15 U.S.C. § 1116 you are hereby advised that a court action has been filed in the U.S. District Court Western District of Texas on the following

Trademarks or Patents. (the patent action involves 35 U.S.C. § 292.);

DOCKET NO. 6:21-cv-00454	DATE FILED 4/30/2021	U.S. DISTRICT COURT Western District of Texas
PLAINTIFF SCRAMOGE, LTD.		DEFENDANT SAMSUNG ELECTRONICS CO., LTD.; and SAMSUNG ELECTRONICS AMERICA, INC.
PATENT OR TRADEMARK NO.	DATE OF PATENT OR TRADEMARK	HOLDER OF PATENT OR TRADEMARK
1 9,553,476	1/24/2017	Scramoge, Ltd.
2 9,825,482	11/21/2017	Scramoge, Ltd.
3 9,997,962	6/12/2018	Scramoge, Ltd.
4		
5		

In the above—entitled case, the following patent(s)/ trademark(s) have been included:

DATE INCLUDED	INCLUDED BY <input type="checkbox"/> Amendment <input type="checkbox"/> Answer <input type="checkbox"/> Cross Bill <input type="checkbox"/> Other Pleading	
PATENT OR TRADEMARK NO.	DATE OF PATENT OR TRADEMARK	HOLDER OF PATENT OR TRADEMARK
1		
2		
3		
4		
5		

In the above—entitled case, the following decision has been rendered or judgement issued:

DECISION/JUDGEMENT

CLERK	(BY) DEPUTY CLERK	DATE
-------	-------------------	------

Copy 1—Upon initiation of action, mail this copy to Director Copy 3—Upon termination of action, mail this copy to Director
 Copy 2—Upon filing document adding patent(s), mail this copy to Director Copy 4—Case file copy



POWER OF ATTORNEY BY APPLICANT

I hereby revoke all previous powers of attorney given in the application identified in either the attached transmittal letter or the boxes below.

Application Number	Filing Date

(Note: The boxes above may be left blank if information is provided on form PTO/AIA/82A.)

- I hereby appoint the Patent Practitioner(s) associated with the following Customer Number as my/our attorney(s) or agent(s), and to transact all business in the United States Patent and Trademark Office connected therewith for the application referenced in the attached transmittal letter (form PTO/AIA/82A) or identified above: 151145
- OR
- I hereby appoint Practitioner(s) named in the attached list (form PTO/AIA/82C) as my/our attorney(s) or agent(s), and to transact all business in the United States Patent and Trademark Office connected therewith for the patent application referenced in the attached transmittal letter (form PTO/AIA/82A) or identified above. (Note: Complete form PTO/AIA/82C.)

Please recognize or change the correspondence address for the application identified in the attached transmittal letter or the boxes above to:

- The address associated with the above-mentioned Customer Number
- OR
- The address associated with Customer Number:

Firm or Individual Name:

Address

City	State	Zip	
Country			
Telephone	Email		

I am the Applicant (if the Applicant is a juristic entity, list the Applicant name in the box):

Scramoge Technology Limited

- Inventor or Joint Inventor (title not required below)
- Legal Representative of a Deceased or Legally Incapacitated Inventor (title not required below)
- Assignee or Person to Whom the Inventor is Under an Obligation to Assign (provide signer's title if applicant is a juristic entity)
- Person Who Otherwise Shows Sufficient Proprietary Interest (e.g., a petition under 37 CFR 1.45(b)(2) was granted in the application or is concurrently being filed with this document) (provide signer's title if applicant is a juristic entity)

SIGNATURE of Applicant for Patent

The undersigned (whose title is supplied below) is authorized to act on behalf of the applicant (e.g., where the applicant is a juristic entity):

Signature	<i>Clara Ogara</i>	Date (Optional)	Feb 19 2021
Name	CLARA OGARA		
Title	DIRECTOR		

NOTE: Signature - This form must be signed by the applicant in accordance with 37 CFR 1.33. See 37 CFR 1.4 for signature requirements and certifications. If more than one applicant, use multiple forms.

Total of _____ forms are submitted

This collection of information is required by 37 CFR 1.151, 1.22, and 1.93. The information is required to obtain or retain a benefit by the public which is to be taxed by the USPTO in processing an application. Confidentiality is governed by 35 U.S.C. 122 and 37 CFR 1.11 and 1.14. This collection is estimated to take 3 minutes to complete, including gathering, preparing, and submitting the completed application form to the USPTO. Time will vary depending upon the individual case. Any comments on the amount of time you require to complete this form and/or suggestions for reducing this burden, should be sent to the Chief Information Officer, U.S. Patent and Trademark Office, U.S. Department of Commerce, P.O. Box 1455, Alexandria, VA 22313-1455. DO NOT SEND FEES OR COMPLETED FORMS TO THIS ADDRESS. SEND TO: Commissioner for Patents, P.O. Box 1460, Alexandria, VA 22313-1460.

If you need assistance in completing the form, call 1-800-PTO-9199 and select option 2.

Under the Paperwork Reduction Act of 1995, no persons are required to respond to a collection of information unless it displays a valid OMB control number.

TRANSMITTAL FOR POWER OF ATTORNEY TO ONE OR MORE REGISTERED PRACTITIONERS

NOTE: This form is to be submitted with the Power of Attorney by Applicant form (PTO/AIA/82B) to identify the application to which the Power of Attorney is directed, in accordance with 37 CFR 1.5, unless the application number and filing date are identified in the Power of Attorney by Applicant form. If neither form PTO/AIA/82A nor form PTO/AIA/82B identifies the application to which the Power of Attorney is directed, the Power of Attorney will not be recognized in the application.

Application Number	14/901,426
Filing Date	12-28-2015
First Named Inventor	Seok BAE
Title	RECEIVING ANTENNA AND WIRELESS POWER RECEIVING DEVICE INCLUDING THE SAME
Art Unit	2859
Examiner Name	DIAO, M BAYE
Attorney Docket Number	0106.001POA1

SIGNATURE of Applicant or Patent Practitioner			
Signature	/Khaled Shami/	Date (Optional)	
Name	Khaled Shami	Registration Number	38,745
Title (if Applicant is a juristic entity)			
Applicant Name (if Applicant is a juristic entity)			

NOTE: This form must be signed in accordance with 37 CFR 1.33. See 37 CFR 1.4(d) for signature requirements and certifications. If more than one applicant, use multiple forms.

*Total of _____ forms are submitted.

This collection of information is required by 37 CFR 1.131, 1.32, and 1.33. The information is required to obtain or retain a benefit by the public which is to file (and by the USPTO to process) an application. Confidentiality is governed by 35 U.S.C. 122 and 37 CFR 1.11 and 1.14. This collection is estimated to take 3 minutes to complete, including gathering, preparing, and submitting the completed application form to the USPTO. Time will vary depending upon the individual case. Any comments on the amount of time you require to complete this form and/or suggestions for reducing this burden, should be sent to the Chief Information Officer, U.S. Patent and Trademark Office, U.S. Department of Commerce, P.O. Box 1450, Alexandria, VA 22313-1450. DO NOT SEND FEES OR COMPLETED FORMS TO THIS ADDRESS. **SEND TO: Commissioner for Patents, P.O. Box 1450, Alexandria, VA 22313-1450.**

If you need assistance in completing the form, call 1-800-PTO-9199 and select option 2.

Under the Paperwork Reduction Act of 1995, no persons are required to respond to a collection of information unless it displays a valid OMB control number.

<p>CHANGE OF CORRESPONDENCE ADDRESS <i>Patent</i></p> <p>Address to: Mail Stop Post Issue Commissioner for Patents P.O. Box 1450 Alexandria, VA 22313-1450</p>	Patent Number	9,997,962
	Issue Date	06-12-2018
	Application Number	14/901,426
	Filing Date	12-28-2015
	First Named Inventor	Seok BAE
	Attorney Docket Number	0106.001POA1

Please change the Correspondence Address for the above-identified patent to:		
<input checked="" type="checkbox"/> The address associated with Customer Number:	151145	
OR		
<input type="checkbox"/> Firm or Individual Name		
Address		
City	State	ZIP
Country		
Telephone	Email	
<p>This form cannot be used to change the data associated with a Customer Number. To change the data associated with an existing Customer Number use "Request for Customer Number Data Change" (PTO/SB/124).</p> <p>This form will not affect any "fee address" provided for the above-identified patent. To change a "fee address" use the "Fee Address Indication Form" (PTO/SB/47).</p> <p>I am the:</p> <p><input type="checkbox"/> Patentee.</p> <p><input type="checkbox"/> If the Patentee was not the applicant for patent (37 CFR 1.42), then a Statement under 37 CFR 3.73(c) (Form PTO/AIA/96 or equivalent) is enclosed or was filed on _____. See 37 CFR 3.71.</p> <p><input checked="" type="checkbox"/> Attorney or agent of record. Registration Number <u>38,745</u>.</p> <p><input type="checkbox"/> Patent practitioner acting in a representative capacity whose correspondence address is the correspondence address of record. Notice has been given to the patentee or owner. Registration Number <u>38,745</u>.</p>		
Signature /Khaled Shami/		
Typed or Printed Name KHALED SHAMI		
Date April 28, 2021	Telephone 202-516-6901	
NOTE: This form must be signed in accordance with 37 CFR 1.33. See 37 CFR 1.4(d) for signature requirements and certifications. Submit multiple forms if more than one signature is required, see below*.		
<input type="checkbox"/> *Total of _____ forms are submitted.		

This collection of information is required by 37 CFR 1.33. The information is required to obtain or retain a benefit by the public which is to file (and by the USPTO to process) an application. Confidentiality is governed by 35 U.S.C. 122 and 37 CFR 1.11 and 1.14. This collection is estimated to take 3 minutes to complete, including gathering, preparing, and submitting the completed application form to the USPTO. Time will vary depending upon the individual case. Any comments on the amount of time you require to complete this form and/or suggestions for reducing this burden, should be sent to the Chief Information Officer, U.S. Patent and Trademark Office, U.S. Department of Commerce, P.O. Box 1450, Alexandria, VA 22313-1450. DO NOT SEND FEES OR COMPLETED FORMS TO THIS ADDRESS. **SEND TO: Mail Stop Post Issue, Commissioner for Patents, P.O. Box 1450, Alexandria, VA 22313-1450.**

If you need assistance in completing the form, call 1-800-PTO-9199 and select option 2.

Privacy Act Statement

The **Privacy Act of 1974 (P.L. 93-579)** requires that you be given certain information in connection with your submission of the attached form related to a patent application or patent. Accordingly, pursuant to the requirements of the Act, please be advised that: (1) the general authority for the collection of this information is 35 U.S.C. 2(b)(2); (2) furnishing of the information solicited is voluntary; and (3) the principal purpose for which the information is used by the U.S. Patent and Trademark Office is to process and/or examine your submission related to a patent application or patent. If you do not furnish the requested information, the U.S. Patent and Trademark Office may not be able to process and/or examine your submission, which may result in termination of proceedings or abandonment of the application or expiration of the patent.

The information provided by you in this form will be subject to the following routine uses:

1. The information on this form will be treated confidentially to the extent allowed under the Freedom of Information Act (5 U.S.C. 552) and the Privacy Act (5 U.S.C. 552a). Records from this system of records may be disclosed to the Department of Justice to determine whether disclosure of these records is required by the Freedom of Information Act.
2. A record from this system of records may be disclosed, as a routine use, in the course of presenting evidence to a court, magistrate, or administrative tribunal, including disclosures to opposing counsel in the course of settlement negotiations.
3. A record in this system of records may be disclosed, as a routine use, to a Member of Congress submitting a request involving an individual, to whom the record pertains, when the individual has requested assistance from the Member with respect to the subject matter of the record.
4. A record in this system of records may be disclosed, as a routine use, to a contractor of the Agency having need for the information in order to perform a contract. Recipients of information shall be required to comply with the requirements of the Privacy Act of 1974, as amended, pursuant to 5 U.S.C. 552a(m).
5. A record related to an International Application filed under the Patent Cooperation Treaty in this system of records may be disclosed, as a routine use, to the International Bureau of the World Intellectual Property Organization, pursuant to the Patent Cooperation Treaty.
6. A record in this system of records may be disclosed, as a routine use, to another federal agency for purposes of National Security review (35 U.S.C. 181) and for review pursuant to the Atomic Energy Act (42 U.S.C. 218(c)).
7. A record from this system of records may be disclosed, as a routine use, to the Administrator, General Services, or his/her designee, during an inspection of records conducted by GSA as part of that agency's responsibility to recommend improvements in records management practices and programs, under authority of 44 U.S.C. 2904 and 2906. Such disclosure shall be made in accordance with the GSA regulations governing inspection of records for this purpose, and any other relevant (*i.e.*, GSA or Commerce) directive. Such disclosure shall not be used to make determinations about individuals.
8. A record from this system of records may be disclosed, as a routine use, to the public after either publication of the application pursuant to 35 U.S.C. 122(b) or issuance of a patent pursuant to 35 U.S.C. 151. Further, a record may be disclosed, subject to the limitations of 37 CFR 1.14, as a routine use, to the public if the record was filed in an application which became abandoned or in which the proceedings were terminated and which application is referenced by either a published application, an application open to public inspection or an issued patent.
9. A record from this system of records may be disclosed, as a routine use, to a Federal, State, or local law enforcement agency, if the USPTO becomes aware of a violation or potential violation of law or regulation.

STATEMENT UNDER 37 CFR 3.73(c)

Applicant/Patent Owner: SCRAMOGE TECHNOLOGY LIMITED
Application No./Patent No.: 9,997,962 Filed/Issue Date: 06-12-2018
Titled: RECEIVING ANTENNA AND WIRELESS POWER RECEIVING DEVICE INCLUDING THE SAME
SCRAMOGE TECHNOLOGY LIMITED, a Corporation

(Name of Assignee) (Type of Assignee, e.g., corporation, partnership, university, government agency, etc.)

states that, for the patent application/patent identified above, it is (choose **one** of options 1, 2, 3 or 4 below):

1. The assignee of the entire right, title, and interest.
2. An assignee of less than the entire right, title, and interest (check applicable box):
- The extent (by percentage) of its ownership interest is _____%. Additional Statement(s) by the owners holding the balance of the interest must be submitted to account for 100% of the ownership interest.
 - There are unspecified percentages of ownership. The other parties, including inventors, who together own the entire right, title and interest are:

Additional Statement(s) by the owner(s) holding the balance of the interest must be submitted to account for the entire right, title, and interest.

3. The assignee of an undivided interest in the entirety (a complete assignment from one of the joint inventors was made). The other parties, including inventors, who together own the entire right, title, and interest are:

Additional Statement(s) by the owner(s) holding the balance of the interest must be submitted to account for the entire right, title, and interest.

4. The recipient, via a court proceeding or the like (e.g., bankruptcy, probate), of an undivided interest in the entirety (a complete transfer of ownership interest was made). The certified document(s) showing the transfer is attached.

The interest identified in option 1, 2 or 3 above (not option 4) is evidenced by either (choose **one** of options A or B below):

- A. An assignment from the inventor(s) of the patent application/patent identified above. The assignment was recorded in the United States Patent and Trademark Office at Reel _____, Frame _____, or for which a copy thereof is attached.

- B. A chain of title from the inventor(s), of the patent application/patent identified above, to the current assignee as follows:

1. From: BAE, SEOK To: LG INNOTEK CO., LTD.

The document was recorded in the United States Patent and Trademark Office at Reel 038336, Frame 0837, or for which a copy thereof is attached.

2. From: LG INNOTEK CO., LTD. To: SCRAMOGE TECHNOLOGY LIMITED

The document was recorded in the United States Patent and Trademark Office at Reel 055335, Frame 0652, or for which a copy thereof is attached.

[Page 1 of 2]

This collection of information is required by 37 CFR 3.73(b). The information is required to obtain or retain a benefit by the public which is to file (and by the USPTO to process) an application. Confidentiality is governed by 35 U.S.C. 122 and 37 CFR 1.11 and 1.14. This collection is estimated to take 12 minutes to complete, including gathering, preparing, and submitting the completed application form to the USPTO. Time will vary depending upon the individual case. Any comments on the amount of time you require to complete this form and/or suggestions for reducing this burden, should be sent to the Chief Information Officer, U.S. Patent and Trademark Office, U.S. Department of Commerce, P.O. Box 1450, Alexandria, VA 22313-1450. DO NOT SEND FEES OR COMPLETED FORMS TO THIS ADDRESS. **SEND TO: Commissioner for Patents, P.O. Box 1450, Alexandria, VA 22313-1450.**

If you need assistance in completing the form, call 1-800-PTO-9199 and select option 2.

Under the Paperwork Reduction Act of 1995, no persons are required to respond to a collection of information unless it displays a valid OMB control number.

STATEMENT UNDER 37 CFR 3.73(c)

3. From: _____ To: _____

The document was recorded in the United States Patent and Trademark Office at
Reel _____, Frame _____, or for which a copy thereof is attached.

4. From: _____ To: _____

The document was recorded in the United States Patent and Trademark Office at
Reel _____, Frame _____, or for which a copy thereof is attached.

5. From: _____ To: _____

The document was recorded in the United States Patent and Trademark Office at
Reel _____, Frame _____, or for which a copy thereof is attached.

6. From: _____ To: _____

The document was recorded in the United States Patent and Trademark Office at
Reel _____, Frame _____, or for which a copy thereof is attached.

Additional documents in the chain of title are listed on a supplemental sheet(s).

As required by 37 CFR 3.73(c)(1)(i), the documentary evidence of the chain of title from the original owner to the assignee was, or concurrently is being, submitted for recordation pursuant to 37 CFR 3.11.

[NOTE: A separate copy (i.e., a true copy of the original assignment document(s)) must be submitted to Assignment Division in accordance with 37 CFR Part 3, to record the assignment in the records of the USPTO. See MPEP 302.08]

The undersigned (whose title is supplied below) is authorized to act on behalf of the assignee.

/Khaled Shami/

Signature

Khaled Shami

Printed or Typed Name

April 28, 2021

Date

38,745

Title or Registration Number

Privacy Act Statement

The **Privacy Act of 1974 (P.L. 93-579)** requires that you be given certain information in connection with your submission of the attached form related to a patent application or patent. Accordingly, pursuant to the requirements of the Act, please be advised that: (1) the general authority for the collection of this information is 35 U.S.C. 2(b)(2); (2) furnishing of the information solicited is voluntary; and (3) the principal purpose for which the information is used by the U.S. Patent and Trademark Office is to process and/or examine your submission related to a patent application or patent. If you do not furnish the requested information, the U.S. Patent and Trademark Office may not be able to process and/or examine your submission, which may result in termination of proceedings or abandonment of the application or expiration of the patent.

The information provided by you in this form will be subject to the following routine uses:

1. The information on this form will be treated confidentially to the extent allowed under the Freedom of Information Act (5 U.S.C. 552) and the Privacy Act (5 U.S.C. 552a). Records from this system of records may be disclosed to the Department of Justice to determine whether disclosure of these records is required by the Freedom of Information Act.
2. A record from this system of records may be disclosed, as a routine use, in the course of presenting evidence to a court, magistrate, or administrative tribunal, including disclosures to opposing counsel in the course of settlement negotiations.
3. A record in this system of records may be disclosed, as a routine use, to a Member of Congress submitting a request involving an individual, to whom the record pertains, when the individual has requested assistance from the Member with respect to the subject matter of the record.
4. A record in this system of records may be disclosed, as a routine use, to a contractor of the Agency having need for the information in order to perform a contract. Recipients of information shall be required to comply with the requirements of the Privacy Act of 1974, as amended, pursuant to 5 U.S.C. 552a(m).
5. A record related to an International Application filed under the Patent Cooperation Treaty in this system of records may be disclosed, as a routine use, to the International Bureau of the World Intellectual Property Organization, pursuant to the Patent Cooperation Treaty.
6. A record in this system of records may be disclosed, as a routine use, to another federal agency for purposes of National Security review (35 U.S.C. 181) and for review pursuant to the Atomic Energy Act (42 U.S.C. 218(c)).
7. A record from this system of records may be disclosed, as a routine use, to the Administrator, General Services, or his/her designee, during an inspection of records conducted by GSA as part of that agency's responsibility to recommend improvements in records management practices and programs, under authority of 44 U.S.C. 2904 and 2906. Such disclosure shall be made in accordance with the GSA regulations governing inspection of records for this purpose, and any other relevant (*i.e.*, GSA or Commerce) directive. Such disclosure shall not be used to make determinations about individuals.
8. A record from this system of records may be disclosed, as a routine use, to the public after either publication of the application pursuant to 35 U.S.C. 122(b) or issuance of a patent pursuant to 35 U.S.C. 151. Further, a record may be disclosed, subject to the limitations of 37 CFR 1.14, as a routine use, to the public if the record was filed in an application which became abandoned or in which the proceedings were terminated and which application is referenced by either a published application, an application open to public inspection or an issued patent.
9. A record from this system of records may be disclosed, as a routine use, to a Federal, State, or local law enforcement agency, if the USPTO becomes aware of a violation or potential violation of law or regulation.

Electronic Acknowledgement Receipt

EFS ID:	42586432
Application Number:	14901426
International Application Number:	
Confirmation Number:	5436
Title of Invention:	RECEIVING ANTENNA AND WIRELESS POWER RECEIVING DEVICE INCLUDING THE SAME
First Named Inventor/Applicant Name:	Seok BAE
Customer Number:	34610
Filer:	Khaled Shami/Susanh Perez
Filer Authorized By:	Khaled Shami
Attorney Docket Number:	DANA-0049
Receipt Date:	29-APR-2021
Filing Date:	28-DEC-2015
Time Stamp:	12:14:46
Application Type:	U.S. National Stage under 35 USC 371

Payment information:

Submitted with Payment	no
------------------------	----

File Listing:

Document Number	Document Description	File Name	File Size(Bytes)/ Message Digest	Multi Part /.zip	Pages (if appl.)
1	Power of Attorney	01060000000_POASigned.pdf	1055768 <small>a163da1e2fda2ffb59b2385b929b44750ed33a63</small>	no	1

Warnings:

Information:					
2	Transmittal Letter	Pat_14901426_POA_Transmittal.pdf	293632 b21940fce4aae01962e7d6290d55698fa7c91d3c	no	1
Warnings:					
Information:					
3	Change of Address	Pat_14901426_aia0123.pdf	313159 1335b1872cbc62d568731cf6b937bc5fde976a24	no	2
Warnings:					
Information:					
4	Assignee showing of ownership per 37 CFR 3.73	Pat_14901426_373_aia0096.pdf	231014 af54f75b57bf36e5ba53fc4e156e813f00c12075	no	3
Warnings:					
Information:					
Total Files Size (in bytes):			1893573		
<p>This Acknowledgement Receipt evidences receipt on the noted date by the USPTO of the indicated documents, characterized by the applicant, and including page counts, where applicable. It serves as evidence of receipt similar to a Post Card, as described in MPEP 503.</p> <p><u>New Applications Under 35 U.S.C. 111</u> If a new application is being filed and the application includes the necessary components for a filing date (see 37 CFR 1.53(b)-(d) and MPEP 506), a Filing Receipt (37 CFR 1.54) will be issued in due course and the date shown on this Acknowledgement Receipt will establish the filing date of the application.</p> <p><u>National Stage of an International Application under 35 U.S.C. 371</u> If a timely submission to enter the national stage of an international application is compliant with the conditions of 35 U.S.C. 371 and other applicable requirements a Form PCT/DO/EO/903 indicating acceptance of the application as a national stage submission under 35 U.S.C. 371 will be issued in addition to the Filing Receipt, in due course.</p> <p><u>New International Application Filed with the USPTO as a Receiving Office</u> If a new international application is being filed and the international application includes the necessary components for an international filing date (see PCT Article 11 and MPEP 1810), a Notification of the International Application Number and of the International Filing Date (Form PCT/RO/105) will be issued in due course, subject to prescriptions concerning national security, and the date shown on this Acknowledgement Receipt will establish the international filing date of the application.</p>					



UNITED STATES PATENT AND TRADEMARK OFFICE

UNITED STATES DEPARTMENT OF COMMERCE
United States Patent and Trademark Office
Address: COMMISSIONER FOR PATENTS
P.O. Box 1450
Alexandria, Virginia 22313-1450
www.uspto.gov

Table with 5 columns: APPLICATION NO., ISSUE DATE, PATENT NO., ATTORNEY DOCKET NO., CONFIRMATION NO.
Row 1: 14/901,426, 06/12/2018, 9997962, DANA-0049, 5436

34610 7590 05/23/2018
KED & ASSOCIATES, LLP
P.O. Box 8638
Reston, VA 20195

ISSUE NOTIFICATION

The projected patent number and issue date are specified above.

Determination of Patent Term Adjustment under 35 U.S.C. 154 (b)
(application filed on or after May 29, 2000)

The Patent Term Adjustment is 206 day(s). Any patent to issue from the above-identified application will include an indication of the adjustment on the front page.

If a Continued Prosecution Application (CPA) was filed in the above-identified application, the filing date that determines Patent Term Adjustment is the filing date of the most recent CPA.

Applicant will be able to obtain more detailed information by accessing the Patent Application Information Retrieval (PAIR) WEB site (http://pair.uspto.gov).

Any questions regarding the Patent Term Extension or Adjustment determination should be directed to the Office of Patent Legal Administration at (571)-272-7702. Questions relating to issue and publication fee payments should be directed to the Application Assistance Unit (AAU) of the Office of Data Management (ODM) at (571)-272-4200.

APPLICANT(s) (Please see PAIR WEB site http://pair.uspto.gov for additional applicants):

LG INNOTEK CO., LTD., Seoul, KOREA, REPUBLIC OF;
Seok BAE, Seoul, KOREA, REPUBLIC OF;
Donchul CHOI, Seoul, KOREA, REPUBLIC OF;
Soon Young Hyun, Seoul, KOREA, REPUBLIC OF;

The United States represents the largest, most dynamic marketplace in the world and is an unparalleled location for business investment, innovation, and commercialization of new technologies. The USA offers tremendous resources and advantages for those who invest and manufacture goods here. Through SelectUSA, our nation works to encourage and facilitate business investment. To learn more about why the USA is the best country in the world to develop technology, manufacture products, and grow your business, visit SelectUSA.gov.

PART B - FEE(S) TRANSMITTAL

Complete and send this form, together with applicable fee(s), to: **Mail** Mail Stop ISSUE FEE
Commissioner for Patents
P.O. Box 1450
Alexandria, Virginia 22313-1450
or Fax (571)-273-2885

INSTRUCTIONS: This form should be used for transmitting the ISSUE FEE and PUBLICATION FEE (if required). Blocks 1 through 5 should be completed where appropriate. All further correspondence including the Patent, advance orders and notification of maintenance fees will be mailed to the current correspondence address as indicated unless corrected below or directed otherwise in Block 1, by (a) specifying a new correspondence address; and/or (b) indicating a separate "FEE ADDRESS" for maintenance fee notifications.

CURRENT CORRESPONDENCE ADDRESS (Note: Use Block 1 for any change of address)

34610 7590 02/15/2018
KED & ASSOCIATES, LLP
 P.O. Box 8638
 Reston, VA 20195

Note: A certificate of mailing can only be used for domestic mailings of the Fee(s) Transmittal. This certificate cannot be used for any other accompanying papers. Each additional paper, such as an assignment or formal drawing, must have its own certificate of mailing or transmission.

Certificate of Mailing or Transmission

I hereby certify that this Fee(s) Transmittal is being deposited with the United States Postal Service with sufficient postage for first class mail in an envelope addressed to the Mail Stop ISSUE FEE address above, or being facsimile transmitted to the USPTO (571) 273-2885, on the date indicated below.

_____ (Depositor's name)
_____ (Signature)
_____ (Date)

APPLICATION NO.	FILING DATE	FIRST NAMED INVENTOR	ATTORNEY DOCKET NO.	CONFIRMATION NO.
14/901,426	12/28/2015	Seok BAE	DANA-0049	5436

TITLE OF INVENTION: RECEIVING ANTENNA AND WIRELESS POWER RECEIVING DEVICE INCLUDING THE SAME

APPLN. TYPE	ENTITY STATUS	ISSUE FEE DUE	PUBLICATION FEE DUE	PREV. PAID ISSUE FEE	TOTAL FEE(S) DUE	DATE DUE
nonprovisional	UNDISCOUNTED	\$1000	\$0	\$0	\$1000	05/15/2018

EXAMINER	ART UNIT	CLASS-SUBCLASS
DIAO, M BAYE	2859	320-108000

1. Change of correspondence address or indication of "Fee Address" (37 CFR 1.363).

Change of correspondence address (or Change of Correspondence Address form PTO/SB/122) attached.

"Fee Address" indication (or "Fee Address" Indication form PTO/SB/47; Rev 03-02 or more recent) attached. **Use of a Customer Number is required.**

2. For printing on the patent front page, list

(1) The names of up to 3 registered patent attorneys or agents OR, alternatively,

(2) The name of a single firm (having as a member a registered attorney or agent) and the names of up to 2 registered patent attorneys or agents. If no name is listed, no name will be printed.

1 KED & ASSOCIATES, LLP

2 _____

3 _____

3. ASSIGNEE NAME AND RESIDENCE DATA TO BE PRINTED ON THE PATENT (print or type)

PLEASE NOTE: Unless an assignee is identified below, no assignee data will appear on the patent. If an assignee is identified below, the document has been filed for recordation as set forth in 37 CFR 3.11. Completion of this form is NOT a substitute for filing an assignment.

(A) NAME OF ASSIGNEE LG INNOTEK CO., LTD.

(B) RESIDENCE: (CITY and STATE OR COUNTRY) SEOUL, REPUBLIC OF KOREA

Please check the appropriate assignee category or categories (will not be printed on the patent): Individual Corporation or other private group entity Government

4a. The following fee(s) are submitted:

Issue Fee

Publication Fee (No small entity discount permitted)

Advance Order - # of Copies _____

4b. Payment of Fee(s): (Please first reapply any previously paid issue fee shown above)

A check is enclosed.

Payment by credit card.

The director is hereby authorized to charge the required fee(s), any deficiency, or credits any overpayment, to Deposit Account Number 16-0607 (enclose an extra copy of this form).

5. Change in Entity Status (from status indicated above)

Applicant certifying micro entity status. See 37 CFR 1.29

Applicant asserting small entity status. See 37 CFR 1.27

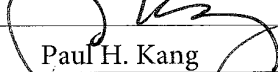
Applicant changing to regular undiscounted fee status.

NOTE: Absent a valid certification of Micro Entity Status (see forms PTO/SB/15A and 15B), issue fee payment in the micro entity amount will not be accepted at the risk of application abandonment.

NOTE: If the application was previously under micro entity status, checking this box will be taken to be a notification of loss of entitlement to micro entity status.

NOTE: Checking this box will be taken to be a notification of loss of entitlement to small or micro entity status, as applicable.

NOTE: This form must be signed in accordance with 37 CFR 1.31 and 1.33. See 37 CFR 1.4 for signature requirements and certifications.

Authorized Signature 

Typed or printed name Paul H. Kang

Date May 9, 2018

Registration No. 66,545

Electronic Patent Application Fee Transmittal

Application Number:	14901426			
Filing Date:	28-Dec-2015			
Title of Invention:	RECEIVING ANTENNA AND WIRELESS POWER RECEIVING DEVICE INCLUDING THE SAME			
First Named Inventor/Applicant Name:	Seok BAE			
Filer:	Daniel Y.J. Kim/Sarah Garrett			
Attorney Docket Number:	DANA-0049			
Filed as Large Entity				
Filing Fees for U.S. National Stage under 35 USC 371				
Description	Fee Code	Quantity	Amount	Sub-Total in USD(\$)
Basic Filing:				
Pages:				
Claims:				
Miscellaneous-Filing:				
Petition:				
Patent-Appeals-and-Interference:				
Post-Allowance-and-Post-Issuance:				
UTILITY APPL ISSUE FEE	1501	1	1000	1000

Description	Fee Code	Quantity	Amount	Sub-Total in USD(\$)
Extension-of-Time:				
Miscellaneous:				
Total in USD (\$)				1000

Electronic Acknowledgement Receipt

EFS ID:	32574935
Application Number:	14901426
International Application Number:	
Confirmation Number:	5436
Title of Invention:	RECEIVING ANTENNA AND WIRELESS POWER RECEIVING DEVICE INCLUDING THE SAME
First Named Inventor/Applicant Name:	Seok BAE
Customer Number:	34610
Filer:	Daniel Y.J. Kim/Sarah Garrett
Filer Authorized By:	Daniel Y.J. Kim
Attorney Docket Number:	DANA-0049
Receipt Date:	09-MAY-2018
Filing Date:	28-DEC-2015
Time Stamp:	12:13:52
Application Type:	U.S. National Stage under 35 USC 371

Payment information:

Submitted with Payment	yes
Payment Type	CARD
Payment was successfully received in RAM	\$1000
RAM confirmation Number	050918INTEFSW12143800
Deposit Account	
Authorized User	

The Director of the USPTO is hereby authorized to charge indicated fees and credit any overpayment as follows:

--	--	--	--	--	--

File Listing:

Document Number	Document Description	File Name	File Size(Bytes)/ Message Digest	Multi Part /.zip	Pages (if appl.)
1	Issue Fee Payment (PTO-85B)	IssueFeeTransmittal.pdf	212393	no	1
			33dcfcc1006f33ce81ae365414b257b8c6dae2fa		

Warnings:

Information:

2	Fee Worksheet (SB06)	fee-info.pdf	30580	no	2
			65dd0c5711303d25434f0ecf53c4ff9773121cc3		

Warnings:

Information:

Total Files Size (in bytes):	242973
-------------------------------------	--------

This Acknowledgement Receipt evidences receipt on the noted date by the USPTO of the indicated documents, characterized by the applicant, and including page counts, where applicable. It serves as evidence of receipt similar to a Post Card, as described in MPEP 503.

New Applications Under 35 U.S.C. 111

If a new application is being filed and the application includes the necessary components for a filing date (see 37 CFR 1.53(b)-(d) and MPEP 506), a Filing Receipt (37 CFR 1.54) will be issued in due course and the date shown on this Acknowledgement Receipt will establish the filing date of the application.

National Stage of an International Application under 35 U.S.C. 371

If a timely submission to enter the national stage of an international application is compliant with the conditions of 35 U.S.C. 371 and other applicable requirements a Form PCT/DO/EO/903 indicating acceptance of the application as a national stage submission under 35 U.S.C. 371 will be issued in addition to the Filing Receipt, in due course.

New International Application Filed with the USPTO as a Receiving Office

If a new international application is being filed and the international application includes the necessary components for an international filing date (see PCT Article 11 and MPEP 1810), a Notification of the International Application Number and of the International Filing Date (Form PCT/RO/105) will be issued in due course, subject to prescriptions concerning national security, and the date shown on this Acknowledgement Receipt will establish the international filing date of the application.



UNITED STATES PATENT AND TRADEMARK OFFICE

UNITED STATES DEPARTMENT OF COMMERCE
United States Patent and Trademark Office
Address: COMMISSIONER FOR PATENTS
P.O. Box 1450
Alexandria, Virginia 22313-1450
www.uspto.gov

NOTICE OF ALLOWANCE AND FEE(S) DUE

34610 7590 02/15/2018
KED & ASSOCIATES, LLP
P.O. Box 8638
Reston, VA 20195

EXAMINER

DIAO, M BAYE

ART UNIT PAPER NUMBER

2859

DATE MAILED: 02/15/2018

Table with 5 columns: APPLICATION NO., FILING DATE, FIRST NAMED INVENTOR, ATTORNEY DOCKET NO., CONFIRMATION NO.

14/901,426 12/28/2015 Seok BAE DANA-0049 5436

TITLE OF INVENTION: RECEIVING ANTENNA AND WIRELESS POWER RECEIVING DEVICE INCLUDING THE SAME

Table with 7 columns: APPLN. TYPE, ENTITY STATUS, ISSUE FEE DUE, PUBLICATION FEE DUE, PREV. PAID ISSUE FEE, TOTAL FEE(S) DUE, DATE DUE

nonprovisional UNDISCOUNTED \$1000 \$0 \$0 \$1000 05/15/2018

THE APPLICATION IDENTIFIED ABOVE HAS BEEN EXAMINED AND IS ALLOWED FOR ISSUANCE AS A PATENT. PROSECUTION ON THE MERITS IS CLOSED. THIS NOTICE OF ALLOWANCE IS NOT A GRANT OF PATENT RIGHTS. THIS APPLICATION IS SUBJECT TO WITHDRAWAL FROM ISSUE AT THE INITIATIVE OF THE OFFICE OR UPON PETITION BY THE APPLICANT. SEE 37 CFR 1.313 AND MPEP 1308.

THE ISSUE FEE AND PUBLICATION FEE (IF REQUIRED) MUST BE PAID WITHIN THREE MONTHS FROM THE MAILING DATE OF THIS NOTICE OR THIS APPLICATION SHALL BE REGARDED AS ABANDONED. THIS STATUTORY PERIOD CANNOT BE EXTENDED. SEE 35 U.S.C. 151. THE ISSUE FEE DUE INDICATED ABOVE DOES NOT REFLECT A CREDIT FOR ANY PREVIOUSLY PAID ISSUE FEE IN THIS APPLICATION. IF AN ISSUE FEE HAS PREVIOUSLY BEEN PAID IN THIS APPLICATION (AS SHOWN ABOVE), THE RETURN OF PART B OF THIS FORM WILL BE CONSIDERED A REQUEST TO REAPPLY THE PREVIOUSLY PAID ISSUE FEE TOWARD THE ISSUE FEE NOW DUE.

HOW TO REPLY TO THIS NOTICE:

I. Review the ENTITY STATUS shown above. If the ENTITY STATUS is shown as SMALL or MICRO, verify whether entitlement to that entity status still applies.

If the ENTITY STATUS is the same as shown above, pay the TOTAL FEE(S) DUE shown above.

If the ENTITY STATUS is changed from that shown above, on PART B - FEE(S) TRANSMITTAL, complete section number 5 titled "Change in Entity Status (from status indicated above)".

For purposes of this notice, small entity fees are 1/2 the amount of undiscounted fees, and micro entity fees are 1/2 the amount of small entity fees.

II. PART B - FEE(S) TRANSMITTAL, or its equivalent, must be completed and returned to the United States Patent and Trademark Office (USPTO) with your ISSUE FEE and PUBLICATION FEE (if required). If you are charging the fee(s) to your deposit account, section "4b" of Part B - Fee(s) Transmittal should be completed and an extra copy of the form should be submitted. If an equivalent of Part B is filed, a request to reapply a previously paid issue fee must be clearly made, and delays in processing may occur due to the difficulty in recognizing the paper as an equivalent of Part B.

III. All communications regarding this application must give the application number. Please direct all communications prior to issuance to Mail Stop ISSUE FEE unless advised to the contrary.

IMPORTANT REMINDER: Maintenance fees are due in utility patents issuing on applications filed on or after Dec. 12, 1980. It is patentee's responsibility to ensure timely payment of maintenance fees when due. More information is available at www.uspto.gov/PatentMaintenanceFees.

PART B - FEE(S) TRANSMITTAL

**Complete and send this form, together with applicable fee(s), to: Mail Mail Stop ISSUE FEE
 Commissioner for Patents
 P.O. Box 1450
 Alexandria, Virginia 22313-1450
 or Fax (571)-273-2885**

INSTRUCTIONS: This form should be used for transmitting the ISSUE FEE and PUBLICATION FEE (if required). Blocks 1 through 5 should be completed where appropriate. All further correspondence including the Patent, advance orders and notification of maintenance fees will be mailed to the current correspondence address as indicated unless corrected below or directed otherwise in Block 1, by (a) specifying a new correspondence address; and/or (b) indicating a separate "FEE ADDRESS" for maintenance fee notifications.

CURRENT CORRESPONDENCE ADDRESS (Note: Use Block 1 for any change of address)

34610 7590 02/15/2018
KED & ASSOCIATES, LLP
 P.O. Box 8638
 Reston, VA 20195

Note: A certificate of mailing can only be used for domestic mailings of the Fee(s) Transmittal. This certificate cannot be used for any other accompanying papers. Each additional paper, such as an assignment or formal drawing, must have its own certificate of mailing or transmission.

Certificate of Mailing or Transmission

I hereby certify that this Fee(s) Transmittal is being deposited with the United States Postal Service with sufficient postage for first class mail in an envelope addressed to the Mail Stop ISSUE FEE address above, or being facsimile transmitted to the USPTO (571) 273-2885, on the date indicated below.

_____ (Depositor's name)
_____ (Signature)
_____ (Date)

APPLICATION NO.	FILING DATE	FIRST NAMED INVENTOR	ATTORNEY DOCKET NO.	CONFIRMATION NO.
14/901,426	12/28/2015	Seok BAE	DANA-0049	5436

TITLE OF INVENTION: RECEIVING ANTENNA AND WIRELESS POWER RECEIVING DEVICE INCLUDING THE SAME

APPLN. TYPE	ENTITY STATUS	ISSUE FEE DUE	PUBLICATION FEE DUE	PREV. PAID ISSUE FEE	TOTAL FEE(S) DUE	DATE DUE
nonprovisional	UNDISCOUNTED	\$1000	\$0	\$0	\$1000	05/15/2018

EXAMINER	ART UNIT	CLASS-SUBCLASS
DIAO, M BAYE	2859	320-108000

<p>1. Change of correspondence address or indication of "Fee Address" (37 CFR 1.363).</p> <p><input type="checkbox"/> Change of correspondence address (or Change of Correspondence Address form PTO/SB/122) attached.</p> <p><input type="checkbox"/> "Fee Address" indication (or "Fee Address" Indication form PTO/SB/47; Rev 03-02 or more recent) attached. Use of a Customer Number is required.</p>	<p>2. For printing on the patent front page, list</p> <p>(1) The names of up to 3 registered patent attorneys or agents OR, alternatively, 1 _____</p> <p>(2) The name of a single firm (having as a member a registered attorney or agent) and the names of up to 2 registered patent attorneys or agents. If no name is listed, no name will be printed. 2 _____</p> <p>3 _____</p>
-------------------------------------------------------------------------------------------------------------------------------------------------------------------------------------------------------------------------------------------------------------------------------------------------------------------------------------------------------------------------------------------------------------------	---------------------------------------------------------------------------------------------------------------------------------------------------------------------------------------------------------------------------------------------------------------------------------------------------------------------------------------------------------------------------------------

3. ASSIGNEE NAME AND RESIDENCE DATA TO BE PRINTED ON THE PATENT (print or type)

PLEASE NOTE: Unless an assignee is identified below, no assignee data will appear on the patent. If an assignee is identified below, the document has been filed for recordation as set forth in 37 CFR 3.11. Completion of this form is NOT a substitute for filing an assignment.

(A) NAME OF ASSIGNEE _____ (B) RESIDENCE: (CITY and STATE OR COUNTRY) _____

Please check the appropriate assignee category or categories (will not be printed on the patent): Individual Corporation or other private group entity Government

<p>4a. The following fee(s) are submitted:</p> <p><input type="checkbox"/> Issue Fee</p> <p><input type="checkbox"/> Publication Fee (No small entity discount permitted)</p> <p><input type="checkbox"/> Advance Order - # of Copies _____</p>	<p>4b. Payment of Fee(s): (Please first reapply any previously paid issue fee shown above)</p> <p><input type="checkbox"/> A check is enclosed.</p> <p><input type="checkbox"/> Payment by credit card. Form PTO-2038 is attached.</p> <p><input type="checkbox"/> The director is hereby authorized to charge the required fee(s), any deficiency, or credits any overpayment, to Deposit Account Number _____ (enclose an extra copy of this form).</p>
-------------------------------------------------------------------------------------------------------------------------------------------------------------------------------------------------------------------------------------------------	-----------------------------------------------------------------------------------------------------------------------------------------------------------------------------------------------------------------------------------------------------------------------------------------------------------------------------------------------------------------------------------------------------------------------------------------------------------

5. **Change in Entity Status** (from status indicated above)

Applicant certifying micro entity status. See 37 CFR 1.29

Applicant asserting small entity status. See 37 CFR 1.27

Applicant changing to regular undiscounted fee status.

NOTE: Absent a valid certification of Micro Entity Status (see forms PTO/SB/15A and 15B), issue fee payment in the micro entity amount will not be accepted at the risk of application abandonment.

NOTE: If the application was previously under micro entity status, checking this box will be taken to be a notification of loss of entitlement to micro entity status.

NOTE: Checking this box will be taken to be a notification of loss of entitlement to small or micro entity status, as applicable.

NOTE: This form must be signed in accordance with 37 CFR 1.31 and 1.33. See 37 CFR 1.4 for signature requirements and certifications.

Authorized Signature _____	Date _____
Typed or printed name _____	Registration No. _____



UNITED STATES PATENT AND TRADEMARK OFFICE

UNITED STATES DEPARTMENT OF COMMERCE
United States Patent and Trademark Office
Address: COMMISSIONER FOR PATENTS
P.O. Box 1450
Alexandria, Virginia 22313-1450
www.uspto.gov

Table with 5 columns: APPLICATION NO., FILING DATE, FIRST NAMED INVENTOR, ATTORNEY DOCKET NO., CONFIRMATION NO.
14/901,426 12/28/2015 Seok BAE DANA-0049 5436

34610 7590 02/15/2018
KED & ASSOCIATES, LLP
P.O. Box 8638
Reston, VA 20195

EXAMINER

DIAO, M BAYE

ART UNIT PAPER NUMBER

2859

DATE MAILED: 02/15/2018

Determination of Patent Term Adjustment under 35 U.S.C. 154 (b)
(Applications filed on or after May 29, 2000)

The Office has discontinued providing a Patent Term Adjustment (PTA) calculation with the Notice of Allowance.

Section 1(h)(2) of the AIA Technical Corrections Act amended 35 U.S.C. 154(b)(3)(B)(i) to eliminate the requirement that the Office provide a patent term adjustment determination with the notice of allowance. See Revisions to Patent Term Adjustment, 78 Fed. Reg. 19416, 19417 (Apr. 1, 2013). Therefore, the Office is no longer providing an initial patent term adjustment determination with the notice of allowance. The Office will continue to provide a patent term adjustment determination with the Issue Notification Letter that is mailed to applicant approximately three weeks prior to the issue date of the patent, and will include the patent term adjustment on the patent. Any request for reconsideration of the patent term adjustment determination (or reinstatement of patent term adjustment) should follow the process outlined in 37 CFR 1.705.

Any questions regarding the Patent Term Extension or Adjustment determination should be directed to the Office of Patent Legal Administration at (571)-272-7702. Questions relating to issue and publication fee payments should be directed to the Customer Service Center of the Office of Patent Publication at 1-(888)-786-0101 or (571)-272-4200.

OMB Clearance and PRA Burden Statement for PTOL-85 Part B

The Paperwork Reduction Act (PRA) of 1995 requires Federal agencies to obtain Office of Management and Budget approval before requesting most types of information from the public. When OMB approves an agency request to collect information from the public, OMB (i) provides a valid OMB Control Number and expiration date for the agency to display on the instrument that will be used to collect the information and (ii) requires the agency to inform the public about the OMB Control Number's legal significance in accordance with 5 CFR 1320.5(b).

The information collected by PTOL-85 Part B is required by 37 CFR 1.311. The information is required to obtain or retain a benefit by the public which is to file (and by the USPTO to process) an application. Confidentiality is governed by 35 U.S.C. 122 and 37 CFR 1.14. This collection is estimated to take 12 minutes to complete, including gathering, preparing, and submitting the completed application form to the USPTO. Time will vary depending upon the individual case. Any comments on the amount of time you require to complete this form and/or suggestions for reducing this burden, should be sent to the Chief Information Officer, U.S. Patent and Trademark Office, U.S. Department of Commerce, P.O. Box 1450, Alexandria, Virginia 22313-1450. DO NOT SEND FEES OR COMPLETED FORMS TO THIS ADDRESS. SEND TO: Commissioner for Patents, P.O. Box 1450, Alexandria, Virginia 22313-1450. Under the Paperwork Reduction Act of 1995, no persons are required to respond to a collection of information unless it displays a valid OMB control number.

Privacy Act Statement

The Privacy Act of 1974 (P.L. 93-579) requires that you be given certain information in connection with your submission of the attached form related to a patent application or patent. Accordingly, pursuant to the requirements of the Act, please be advised that: (1) the general authority for the collection of this information is 35 U.S.C. 2(b)(2); (2) furnishing of the information solicited is voluntary; and (3) the principal purpose for which the information is used by the U.S. Patent and Trademark Office is to process and/or examine your submission related to a patent application or patent. If you do not furnish the requested information, the U.S. Patent and Trademark Office may not be able to process and/or examine your submission, which may result in termination of proceedings or abandonment of the application or expiration of the patent.

The information provided by you in this form will be subject to the following routine uses:

1. The information on this form will be treated confidentially to the extent allowed under the Freedom of Information Act (5 U.S.C. 552) and the Privacy Act (5 U.S.C. 552a). Records from this system of records may be disclosed to the Department of Justice to determine whether disclosure of these records is required by the Freedom of Information Act.
2. A record from this system of records may be disclosed, as a routine use, in the course of presenting evidence to a court, magistrate, or administrative tribunal, including disclosures to opposing counsel in the course of settlement negotiations.
3. A record in this system of records may be disclosed, as a routine use, to a Member of Congress submitting a request involving an individual, to whom the record pertains, when the individual has requested assistance from the Member with respect to the subject matter of the record.
4. A record in this system of records may be disclosed, as a routine use, to a contractor of the Agency having need for the information in order to perform a contract. Recipients of information shall be required to comply with the requirements of the Privacy Act of 1974, as amended, pursuant to 5 U.S.C. 552a(m).
5. A record related to an International Application filed under the Patent Cooperation Treaty in this system of records may be disclosed, as a routine use, to the International Bureau of the World Intellectual Property Organization, pursuant to the Patent Cooperation Treaty.
6. A record in this system of records may be disclosed, as a routine use, to another federal agency for purposes of National Security review (35 U.S.C. 181) and for review pursuant to the Atomic Energy Act (42 U.S.C. 218(c)).
7. A record from this system of records may be disclosed, as a routine use, to the Administrator, General Services, or his/her designee, during an inspection of records conducted by GSA as part of that agency's responsibility to recommend improvements in records management practices and programs, under authority of 44 U.S.C. 2904 and 2906. Such disclosure shall be made in accordance with the GSA regulations governing inspection of records for this purpose, and any other relevant (i.e., GSA or Commerce) directive. Such disclosure shall not be used to make determinations about individuals.
8. A record from this system of records may be disclosed, as a routine use, to the public after either publication of the application pursuant to 35 U.S.C. 122(b) or issuance of a patent pursuant to 35 U.S.C. 151. Further, a record may be disclosed, subject to the limitations of 37 CFR 1.14, as a routine use, to the public if the record was filed in an application which became abandoned or in which the proceedings were terminated and which application is referenced by either a published application, an application open to public inspection or an issued patent.
9. A record from this system of records may be disclosed, as a routine use, to a Federal, State, or local law enforcement agency, if the USPTO becomes aware of a violation or potential violation of law or regulation.

Notice of Allowability	Application No. 14/901,426	Applicant(s) BAE ET AL.	
	Examiner M'BAYE DIAO	Art Unit 2859	AIA (First Inventor to File) Status Yes

-- The MAILING DATE of this communication appears on the cover sheet with the correspondence address--

All claims being allowable, PROSECUTION ON THE MERITS IS (OR REMAINS) CLOSED in this application. If not included herewith (or previously mailed), a Notice of Allowance (PTOL-85) or other appropriate communication will be mailed in due course. **THIS NOTICE OF ALLOWABILITY IS NOT A GRANT OF PATENT RIGHTS.** This application is subject to withdrawal from issue at the initiative of the Office or upon petition by the applicant. See 37 CFR 1.313 and MPEP 1308.

1. This communication is responsive to Amendment filed on 12/19/2017.
 A declaration(s)/affidavit(s) under **37 CFR 1.130(b)** was/were filed on _____.

2. An election was made by the applicant in response to a restriction requirement set forth during the interview on _____; the restriction requirement and election have been incorporated into this action.

3. The allowed claim(s) is/are 1,9,13, and 23-38 (renumbered 1-19). As a result of the allowed claim(s), you may be eligible to benefit from the **Patent Prosecution Highway** program at a participating intellectual property office for the corresponding application. For more information, please see http://www.uspto.gov/patents/init_events/pph/index.jsp or send an inquiry to PPHfeedback@uspto.gov.

4. Acknowledgment is made of a claim for foreign priority under 35 U.S.C. § 119(a)-(d) or (f).

Certified copies:

a) All b) Some *c) None of the:

1. Certified copies of the priority documents have been received.

2. Certified copies of the priority documents have been received in Application No. _____.

3. Copies of the certified copies of the priority documents have been received in this national stage application from the International Bureau (PCT Rule 17.2(a)).

* Certified copies not received: _____.

Applicant has THREE MONTHS FROM THE "MAILING DATE" of this communication to file a reply complying with the requirements noted below. Failure to timely comply will result in ABANDONMENT of this application.
THIS THREE-MONTH PERIOD IS NOT EXTENDABLE.

5. CORRECTED DRAWINGS (as "replacement sheets") must be submitted.
 including changes required by the attached Examiner's Amendment / Comment or in the Office action of Paper No./Mail Date _____.

Identifying indicia such as the application number (see 37 CFR 1.84(c)) should be written on the drawings in the front (not the back) of each sheet. Replacement sheet(s) should be labeled as such in the header according to 37 CFR 1.121(d).

6. DEPOSIT OF and/or INFORMATION about the deposit of BIOLOGICAL MATERIAL must be submitted. Note the attached Examiner's comment regarding REQUIREMENT FOR THE DEPOSIT OF BIOLOGICAL MATERIAL.

Attachment(s)

1. <input type="checkbox"/> Notice of References Cited (PTO-892)	5. <input checked="" type="checkbox"/> Examiner's Amendment/Comment
2. <input checked="" type="checkbox"/> Information Disclosure Statements (PTO/SB/08), Paper No./Mail Date <u>12/19/2017</u>	6. <input checked="" type="checkbox"/> Examiner's Statement of Reasons for Allowance
3. <input type="checkbox"/> Examiner's Comment Regarding Requirement for Deposit of Biological Material	7. <input checked="" type="checkbox"/> Other <u>Examiner's Amendment to the Specification.</u>
4. <input type="checkbox"/> Interview Summary (PTO-413), Paper No./Mail Date _____	

/M'BAYE DIAO/ Primary Examiner, Art Unit 2859	01/29/2018
--------------------------------------------------	------------

DETAILED ACTION

Notice of Pre-AIA or AIA Status

1. The present application, filed on or after March 16, 2013, is being examined under the first inventor to file provisions of the AIA.

Response to Amendment

2. Acknowledgement is made of amendment filed on 12/19/2017 in which claims 1,9, and 13 are currently amended, claims 2-8,10-12 and 14-22 have been canceled while claims 23-38 have been newly added. By this amendment, claims 1,9,13, and 23-38 are now pending in the application.

Information Disclosure Statement

3. The information disclosure statement (IDS) submitted on 12/19/2017 is in compliance with the provisions of 37 CFR 1.97. Accordingly, the information disclosure statement is being considered by the examiner.

EXAMINER'S AMENDMENT

4. An examiner's amendment to the record appears below. Should the changes and/or additions be unacceptable to applicant, an amendment may be filed as provided by 37 CFR 1.312. To ensure consideration of such an amendment, it MUST be submitted no later than the payment of the issue fee.

Authorization for this examiner's amendment was given in an interview with Paul H. Kang Reg. No. on 66,545.

The application has been amended as follows: **Replace claim 38 with the following:**

38. (~~New~~ Currently Amended) The wireless power receiving apparatus of claim ~~38~~ 13, further comprising a NFC coil disposed to surround a side portion of the receiving coil.

Replace paragraphs [0026],[0027], and [0028] with the attached Amendments to the specification.

Allowable Subject Matter

5. The following is an examiner's statement of reasons for allowance: Claims 1,9,13, and 23-38 (renumbered 1-19) are allowed over the prior art of record.

6. Regarding claim 1, the prior art of record along with the art filed on 12/19/2017 fails to teach or reasonably suggest,

7. As in claim 1: a power receiving antenna comprising: a substrate; a soft magnetic layer comprising a first magnetic sheet disposed on the substrate and a second magnetic sheet disposed on the first magnetic sheet; a receiving coil disposed on the second magnetic sheet; and an adhesive layer formed between the second magnetic sheet and the receiving coil; wherein the adhesive layer includes a first adhesive layer in contact with the second magnetic sheet, a second adhesive layer in contact with the receiving coil, and an insulating layer disposed between the first adhesive layer and the second adhesive layer, and wherein a height of a highest position of the second magnetic sheet from the substrate is higher than a height of a lowest position of the receiving coil from the substrate.

8. As in claim 9: A method of fabricating a wireless power receiving antenna, ...comprising: preparing a substrate; disposing a first soft magnetic sheet including a Fe-Si based alloy on the substrate; stacking a plurality of the soft magnetic sheets by

stacking a second soft magnetic sheet including the Fe-Si based alloy on the first soft magnetic sheet; disposing an adhesive layer on the second soft magnetic sheet; disposing a receiving coil on the adhesive layer; and compressing the plurality of the soft magnetic sheets, the adhesive layer, and the receiving coil, wherein the adhesive layer includes a first adhesive layer in contact with the second soft magnetic sheet, a second adhesive layer in contact with the receiving coil, and an insulating layer disposed between the first adhesive layer and the second adhesive layer, and wherein compressing the plurality of the soft magnetic sheets, the adhesive layer, and the receiving coil includes forming a height of a highest position of the second September 22, 2017 magnetic sheet from the substrate so to be higher than a height of a lowest position of the receiving coil from the substrate.

9. As in claim 13: A wireless power receiving apparatus, comprising a receiving circuit and a power receiving antenna, the wireless power receiving antenna comprising: a substrate; a soft magnetic layer comprising a first magnetic sheet disposed on the substrate and a second magnetic sheet disposed on the first magnetic sheet; a receiving coil disposed on the second magnetic sheet, and an adhesive layer formed between the second magnetic sheet and the receiving coil; wherein the adhesive layer includes a first adhesive layer in contact with the second magnetic sheet, a second adhesive layer in contact with the receiving coil, and an insulating layer disposed between the first adhesive layer and the second adhesive layer, and wherein a height of a highest position of the second magnetic sheet from the substrate is higher than a height of a lowest position of the receiving coil from the substrate.

10. Claims 23-30 depend either directly or indirectly from claim 1 and thus are also allowed for the same reasons.

11. Claims 31-37 depend either directly or indirectly from claim 9 and thus are also allowed for the same reasons.

12. Claim 38 depend directly from claim 13 and thus is also allowed for the same reasons.

Any comments considered necessary by applicant must be submitted no later than the payment of the issue fee and, to avoid processing delays, should preferably accompany the issue fee. Such submissions should be clearly labeled "Comments on Statement of Reasons for Allowance."

Conclusion

Any inquiry concerning this communication or earlier communications from the examiner should be directed to M'BAYE DIAO whose telephone number is (571)272-6127. The examiner can normally be reached on 8:30-7:00; Friday off.


Examiner interviews are available via telephone, in-person, and video conferencing using a USPTO supplied web-based collaboration tool. To schedule an interview, applicant is encouraged to use the USPTO Automated Interview Request (AIR) at <http://www.uspto.gov/interviewpractice>.

If attempts to reach the examiner by telephone are unsuccessful, the examiner's supervisor, DREW DUNN can be reached on 571-272-2312. The fax phone number for the organization where this application or proceeding is assigned is 571-273-8300.

Information regarding the status of an application may be obtained from the Patent Application Information Retrieval (PAIR) system. Status information for published applications may be obtained from either Private PAIR or Public PAIR. Status information for unpublished applications is available through Private PAIR only. For more information about the PAIR system, see <http://pair-direct.uspto.gov>. Should you have questions on access to the Private PAIR system, contact the Electronic Business Center (EBC) at 866-217-9197 (toll-free). If you would like assistance from a USPTO Customer Service Representative or access to the automated information system, call 800-786-9199 (IN USA OR CANADA) or 571-272-1000.

M'baye Diao
Primary Examiner
Art Unit 2859

/M'BAYE DIAO/
Primary Examiner, Art Unit 2859
January 29, 2018

Search Notes 	Application/Control No. 14901426	Applicant(s)/Patent Under Reexamination BAE ET AL.
	Examiner M'BAYE DIAO	Art Unit 2859

CPC- SEARCHED		
Symbol	Date	Examiner
H01Q 7/06	09/17/2017	MD
H02J50/20,27; H02J7/025	09/17/2017	MD

CPC COMBINATION SETS - SEARCHED		
Symbol	Date	Examiner

US CLASSIFICATION SEARCHED			
Class	Subclass	Date	Examiner
320	108	09/17/2017	MD
307	104	09/17/2017	MD

* See search history printout included with this form or the SEARCH NOTES box below to determine the scope of the search.

SEARCH NOTES		
Search Notes	Date	Examiner
EAST(Search Notes Attached).	09/17/2017	MD
Inventor Name and Assignee search (EAST).	09/16/2017	MD
PLUS Search Conducted.	08/22/2017	MD
Updated Search above.	01/29/2018	MD

INTERFERENCE SEARCH			
US Class/ CPC Symbol	US Subclass / CPC Group	Date	Examiner
	See attached Text.	01/29/2018	MD

	M'BAYE DIAO/ Primary Examiner.Art Unit 2859
--	------------------------------------------------

EAST Search History

EAST Search History (Prior Art)

Ref #	Hits	Search Query	DBs	Default Operator	Plurals	Time Stamp
S1	1	"20160156215"	US-PGPUB; USPAT; EPO	OR	ON	2017/09/17 08:24
S2	1	"20160156103"	US-PGPUB; USPAT; EPO	OR	ON	2017/09/17 08:25
S3	2	"9504194".pn.	US-PGPUB; USPAT; EPO	OR	ON	2017/09/17 09:14
S4	1	"9252611".pn.	US-PGPUB; USPAT; EPO	OR	ON	2017/09/17 09:56
S5	1	"20130249302"	US-PGPUB; USPAT; EPO	OR	ON	2017/09/17 10:03
S6	11	reciv\$3 near (antenna choke coil)	US-PGPUB; USPAT; EPO	OR	ON	2017/09/17 10:31
S7	2522191	substrate	US-PGPUB; USPAT; EPO	OR	ON	2017/09/17 10:31
S8	7113	soft near magnetic near layer	US-PGPUB; USPAT; EPO	OR	ON	2017/09/17 10:31
S9	40087	receiv\$3 near coil	US-PGPUB; USPAT; EPO	OR	ON	2017/09/17 10:32
S10	234770	adhesive near layer	US-PGPUB; USPAT; EPO	OR	ON	2017/09/17 10:32
S11	40317	receiv\$3 near (coil choke)	US-PGPUB; USPAT; EPO	OR	ON	2017/09/17 10:32
S12	245187	receiv\$3 near (antenna choke coil)	US-PGPUB; USPAT; EPO	OR	ON	2017/09/17 10:33

EAST Search History

S13	1	S12 with (S7 same S8 same S9 same S10)	US-PGPUB; USPAT; EPO	OR	ON	2017/09/17 10:34
S14	1	S12 and (S7 same S8 same S9 same S10)	US-PGPUB; USPAT; EPO	OR	ON	2017/09/17 10:34
S15	7	S12 and (S7 and S8 and S9 and S10)	US-PGPUB; USPAT; EPO	OR	ON	2017/09/17 10:34
S16	2	"20130169399"	US-PGPUB; USPAT; EPO	OR	ON	2017/09/17 10:41
S17	1	"9362776".pn.	US-PGPUB; USPAT; EPO	OR	ON	2017/09/17 10:59
S18	581	S10 S11 S12	US-PGPUB; USPAT; EPO	AND	ON	2017/09/17 11:21
S19	5781	S7 S8	US-PGPUB; USPAT; EPO	AND	ON	2017/09/17 11:21
S20	7	S18 and S19	US-PGPUB; USPAT; EPO	AND	ON	2017/09/17 11:21
S21	148	(US-4631766-\$ or US-5358110-\$ or US-5382223-\$ or US-5399051-\$ or US-6081948-\$ or US-4276884-\$ or US-4278456-\$ or US-4286696-\$ or US-4300865-\$ or US-4317733-\$ or US-4319616-\$ or US-4350375-\$ or US-4361090-\$ or US-4381830-\$ or US-4392012-\$ or US-4396799-\$ or US-4411460-\$ or US-4440706-\$ or US-4444795-\$ or US-4480513-\$ or US-4491018-\$ or US-4501034-\$ or US-4522603-\$ or US-4536165-\$ or US-4555806-\$ or US-4587582-\$).did. or (US-4590542-\$ or US-4590340-\$ or US-4610676-\$ or US-4761032-\$ or US-4791751-\$ or US-4869014-\$ or US-4911153-\$ or US-4924121-\$ or US-4933258-\$ or US-4938396-\$ or US-4974771-\$ or US-5178107-\$ or US-5202176-\$ or US-5226674-\$ or US-5230178-\$ or US-5243799-\$ or US-5244277-\$ or US-5289979-\$ or US-5292265-\$ or US-5344086-\$ or US-5360112-\$ or US-5369079-\$ or US-5370486-\$ or US-5374129-\$ or US-5405095-\$ or US-5415573-\$ or US-5417668-\$).did. or (US-5437364-\$ or US-5443214-\$ or US-5452794-\$ or US-5477519-\$ or US-5505477-\$ or US-	USPAT	OR	ON	2017/09/17 11:23

		5536985-\$ or US-5535462-\$ or US-5542753-\$ or US-5562215-\$ or US-5591207-\$ or US-5604752-\$ or US-5621764-\$ or US-5660410-\$ or US-5669493-\$ or US-5690350-\$ or US-5711581-\$ or US-5717872-\$ or US-5727029-\$ or US-5728170-\$ or US-5766174-\$ or US-5769086-\$ or US-5791690-\$ or US-5806876-\$ or US-5845512-\$ or US-5845406-\$ or US-5853188-\$ or US-5872835-\$).did. or (US-5894669-\$ or US-5899160-\$ or US-5906058-\$ or US-5915720-\$ or US-6002716-\$ or US-6035040-\$ or US-6044106-\$ or US-6044111-\$ or US-6099530-\$ or US-6109583-\$ or US-6115435-\$ or US-6134188-\$ or US-6138437-\$ or US-6168183-\$ or US-6192618-\$ or US-6193515-\$ or US-6209771-\$ or US-6221019-\$ or US-6244808-\$ or US-3617078-\$ or US-3642312-\$ or US-3915833-\$ or US-3804184-\$ or US-4024945-\$ or US-4043445-\$ or US-4062569-\$ or US-4160230-\$).did. or (US-4166507-\$ or US-4179829-\$ or US-4068581-\$ or US-4106868-\$ or US-4109556-\$ or US-4129059-\$ or US-4242853-\$ or US-4243122-\$ or US-4243851-\$ or US-4245158-\$ or US-4244459-\$ or US-4244360-\$ or US-4244123-\$ or US-4245360-\$ or US-4245960-\$ or US-4245456-\$ or US-4246738-\$ or US-4248228-\$ or US-4249432-\$ or US-4251066-\$ or US-4252324-\$ or US-4252135-\$ or US-4254206-\$ or US-4254908-\$ or US-4256109-\$ or US-4256952-\$ or US-4259160-\$).did. or (US-4261054-\$ or US-4261366-\$ or US-4262909-\$ or US-4264549-\$ or US-4265167-\$ or US-4267794-\$ or US-4268991-\$ or US-4270070-\$ or US-4270720-\$ or US-4270719-\$ or US-4270426-\$ or US-4275535-\$ or US-4278236-\$ or US-4278029-\$).did.				
S22	0	S18 and S21	US-PGPUB; USPAT; EPO	OR	ON	2017/09/17 11:23
S23	13392	(320/108;307/104;455/41.1,572,573).ccls.	US-PGPUB; USPAT; EPO	OR	ON	2017/09/17 11:24
S24	40	S18 and S23	US-PGPUB; USPAT; EPO	OR	ON	2017/09/17 11:24
S25	11955	(H04B5/0037 H02J7/025 H02J5/005).cpc.	US-PGPUB; USPAT; EPO	OR	ON	2017/09/17 11:28
S26	105	S18 and S25	US-	OR	ON	2017/09/17

			PGPUB; USPAT; EPO			11:28
S27	1	(S24 S26) and ((adhesive near layer) near formed near between near5 (soft near magnetic near layer))	US- PGPUB; USPAT; EPO	OR	ON	2017/09/17 11:30
S28	2	(S24 S26) and ((adhesive near layer) with formed same between near5 (soft near magnetic near layer))	US- PGPUB; USPAT; EPO	OR	ON	2017/09/17 11:31
S29	6	(S24 S26) and S8 and S10 and S12	US- PGPUB; USPAT; EPO	OR	ON	2017/09/17 11:34
S30	1	(soft near magnetic near layer) with (groove near section)	US- PGPUB; USPAT; EPO	OR	ON	2017/09/17 15:15
S31	3	(soft near magnetic near layer) same (groove near section)	US- PGPUB; USPAT; EPO	OR	ON	2017/09/17 15:22
S32	4	("20090121677" "20100007215" "20100052992" "20110050382").PN.	US- PGPUB; USPAT	OR	ON	2017/09/17 15:26


EAST Search History (Interference)

Ref #	Hits	Search Query	DBs	Default Operator	Plurals	Time Stamp
S33	0	(WI RELESS AND RECEI V\$3 AND SUBSTRATE AND SOFT AND MAGNETI C AND LAYER AND RECEI V\$3 AND COI L AND ADHESI VE AND LAYER AND INSULAT\$3 AND HIGHEST AND LOWEST AND POSI TION).CLM.	US- PGPUB; USPAT	OR	OFF	2018/01/29 13:58
S34	0	(WI RELESS AND SUBSTRATE AND SOFT AND MAGNETI C AND LAYER AND RECEI V\$3 AND COI L AND ADHESI VE AND LAYER AND INSULAT\$3 AND HEI GHT AND HIGHEST AND LOWEST AND POSI TION).CLM.	US- PGPUB; USPAT	OR	OFF	2018/01/29 13:59
S35	0	(WI RELESS AND SUBSTRATE AND SOFT AND MAGNETI C AND LAYER AND RECEI V\$3 AND COI L AND ADHESI VE AND LAYER AND INSULAT\$3 AND HEI GHT AND POSI TION).CLM.	US- PGPUB; USPAT	OR	OFF	2018/01/29 14:00
S36	0	(SUBSTRATE AND SOFT AND MAGNETI C AND LAYER AND RECEI V\$3 AND COI L AND ADHESI VE AND LAYER AND INSULAT\$3 AND HEI GHT AND POSI TION).CLM.	US- PGPUB; USPAT	OR	OFF	2018/01/29 14:00
S37	0	(SUBSTRATE AND SOFT AND MAGNETI C AND LAYER AND RECEI V\$3 AND COI L AND ADHESI VE AND LAYER AND INSULAT\$3 AND HEI GHT).CLM.	US- PGPUB; USPAT	OR	OFF	2018/01/29 14:00
S38	0	(SUBSTRATE AND SOFT AND MAGNETI C AND LAYER AND RECEI V\$3 AND COI L AND INSULAT\$3 AND HEI GHT).CLM.	US- PGPUB; USPAT	OR	OFF	2018/01/29 14:01
S39	12	(SUBSTRATE AND SOFT AND MAGNETI C AND LAYER AND RECEI V\$3 AND COI L AND	US- PGPUB;	OR	OFF	2018/01/29 14:01

	INSULAT\$3).CLM.	USPAT		
--	-------------------	-------	--	--


1/ 29/ 2018 5:21:02 PM

C:\Users\mdiao\Documents\EAST\Workspaces\mbaye_01426.wsp

Index of Claims 	Application/Control No. 14901426	Applicant(s)/Patent Under Reexamination BAE ET AL.
	Examiner M'BAYE DIAO	Art Unit 2859

✓	Rejected	-	Cancelled	N	Non-Elected	A	Appeal
=	Allowed	÷	Restricted	I	Interference	O	Objected

<input type="checkbox"/> Claims renumbered in the same order as presented by applicant		<input type="checkbox"/> CPA		<input type="checkbox"/> T.D.		<input type="checkbox"/> R.1.47	
CLAIM		DATE					
Final	Original	09/17/2017	01/29/2018				
1	1	✓					
	2	○	-				
	3	✓	-				
	4	✓	-				
	5	○	-				
	6	○	-				
	7	✓	-				
	8	✓	-				
10	9	=	=				
	10	=	-				
	11	-	-				
	12	-	-				
18	13	✓	=				
	14	✓	-				
	15	✓	-				
	16	✓	-				
	17	=	-				
	18	=	-				
	19	=	-				
	20	○	-				
	21	✓	-				
	22	✓	-				
2	23		=				
3	24		=				
4	25		=				
5	26		=				
6	27		=				
7	28		=				
8	29		=				
9	30		=				
11	31		=				
12	32		=				
13	33		=				
14	34		=				
15	35		=				
16	36		=				

<i>Index of Claims</i> 	Application/Control No. 14901426	Applicant(s)/Patent Under Reexamination BAE ET AL.
	Examiner M'BAYE DIAO	Art Unit 2859

✓	Rejected	-	Cancelled	N	Non-Elected	A	Appeal
=	Allowed	÷	Restricted	I	Interference	O	Objected

<input type="checkbox"/> Claims renumbered in the same order as presented by applicant		<input type="checkbox"/> CPA		<input type="checkbox"/> T.D.		<input type="checkbox"/> R.1.47			
CLAIM		DATE							
Final	Original	09/17/2017	01/29/2018						
17	37		=						
19	38		=						

Approved
/MD/



Mailing Address:
P.O. Box 8638, Reston, VA 20195
Street Address:
1916 Association Drive, Reston, VA 20191
Tel: 703.766.3777 Fax: 703.766.3644
www.ked-iplaw.com
mail@ked-iplaw.com

FACSIMILE COVER SHEET

To:	Examiner M. Baye DIAO U.S. Patent & Trademark Office	From:	Paul H. Kang, Esq.
Fax:	(571) 273-6127	Date:	February 7, 2018
Phone:	(571) 272-6127	Pages:	2
Re:	U.S. Patent Application Serial No. 14/901,426	cc:	
<input type="checkbox"/> Urgent <input type="checkbox"/> For Review <input type="checkbox"/> Please Comment <input type="checkbox"/> Please Reply <input type="checkbox"/> Please Recycle			

Examiner Diao,

Per our discussion today, attached are proposed amendments to the specification to incorporate the description of FIG. 11. We hereby authorize this amendment to place this case in condition for allowance, as we discussed.

We look forward to the Notice of Allowance. Should you have any questions or comments, please do not hesitate to contact me. Thank you for your time and attention in this matter.

Best regards,

Paul H. Kang, Esq.
KED & Associates, LLP
1916 Association Drive
Reston, Virginia 20191
Reg. No. 66,545
E-mail: phk@ked-iplaw.com
Telephone: (703) 766-3755
Facsimile: (703) 766-3644

IMPORTANT

The information contained in this facsimile is intended only for the use of the individual or entity to whom it is addressed. If you are not the intended recipient, you are hereby notified that any use, dissemination, distribution or copying of this communication is strictly prohibited. If you have received this facsimile in error, please immediately notify us by telephone, and return the original message to us at the address above via the U.S. Postal Service. Thank you.

Approved
/MD/

Docket No.: DANA-0049
Serial No. 14/901,426

PATENT

PROPOSED AMENDMENTS – FOR DISCUSSION PURPOSES ONLY

AMENDMENTS TO THE SPECIFICATION

Please replace paragraph [0026] with the following amended paragraph:


~~[0026] FIG. 9 is a cross-sectional view illustrating a soft magnetic layer and a receiving coil in accordance with a comparative example and an example of the present invention and FIG. 10 is a graph illustrating a measurement result of a transmission efficiency in accordance with a comparative example and an example of the present invention.~~

Please add the following new paragraph after paragraph [0026]:

[0027] FIG. 10 is a graph illustrating a measurement result of a transmission efficiency in accordance with a comparative example and an example of the present invention.

Please add the following new paragraph after paragraph [0027]:


[0028] FIG. 11 is a graph illustrating a pressure condition and heat treatment condition in accordance with an embodiment of the present invention.

Issue Classification 	Application/Control No. 14901426	Applicant(s)/Patent Under Reexamination BAE ET AL.	
	Examiner M'BAYE DIAO	Art Unit 2859	

CPC					
Symbol				Type	Version
H02J	50	70		F	2016-02-01
H02J	50	10		I	2016-02-01
H04B	5	0037		A	2013-01-01
H01Q	7	06		I	2013-01-01
H02J	7	025		I	2013-01-01
H02J	50	20		I	2016-02-01
H02J	50	27		I	2016-02-01


CPC Combination Sets				
Symbol	Type	Set	Ranking	Version

NONE		Total Claims Allowed:	
(Assistant Examiner)	(Date)	19	
/M'BAYE DIAO/ Primary Examiner.Art Unit 2859	01/29/2018	O.G. Print Claim(s)	O.G. Print Figure
(Primary Examiner)	(Date)	1	2

Issue Classification 	Application/Control No. 14901426	Applicant(s)/Patent Under Reexamination BAE ET AL.
	Examiner M'BAYE DIAO	Art Unit 2859

US ORIGINAL CLASSIFICATION					INTERNATIONAL CLASSIFICATION								
CLASS		SUBCLASS			CLAIMED				NON-CLAIMED				
320		108			H	0	2	J	7 / 00 (2006.01.01)				
CROSS REFERENCE(S)					H	0	1	F	27 / 42 (2006.01.01)				
CLASS	SUBCLASS (ONE SUBCLASS PER BLOCK)												
307	104												

NONE		Total Claims Allowed:	
		19	
(Assistant Examiner)	(Date)		
/M'BAYE DIAO/ Primary Examiner. Art Unit 2859	01/29/2018	O.G. Print Claim(s)	O.G. Print Figure
(Primary Examiner)	(Date)	1	2

Issue Classification 	Application/Control No. 14901426	Applicant(s)/Patent Under Reexamination BAE ET AL.
	Examiner M'BAYE DIAO	Art Unit 2859

<input type="checkbox"/> Claims renumbered in the same order as presented by applicant		<input type="checkbox"/> CPA		<input type="checkbox"/> T.D.		<input type="checkbox"/> R.1.47									
Final	Original	Final	Original	Final	Original	Final	Original	Final	Original	Final	Original	Final	Original	Final	Original
1	1		17	13	33										
	2		18	14	34										
	3		19	15	35										
	4		20	16	36										
	5		21	17	37										
	6		22	19	38										
	7	2	23												
	8	3	24												
10	9	4	25												
	10	5	26												
	11	6	27												
	12	7	28												
18	13	8	29												
	14	9	30												
	15	11	31												
	16	12	32												

NONE		Total Claims Allowed:	
(Assistant Examiner)	(Date)	19	
/M'BAYE DIAO/ Primary Examiner. Art Unit 2859	01/29/2018	O.G. Print Claim(s)	O.G. Print Figure
(Primary Examiner)	(Date)	1	2

Docket No.: **DANA-0049**

PATENT

IN THE UNITED STATES PATENT AND TRADEMARK OFFICE

In re Application of:

Confirmation No.: **5436**

**Seok BAE; Donchul CHOI; and Soon
Young HYUN**

Group Art Unit: **2859**

Serial No.: **14/901,426**

Examiner: **M. Baye DIAO**

Filed: **December 28, 2015**

Customer No.: **34610**

For: **RECEIVING ANTENNA AND WIRELESS POWER RECEIVING
DEVICE INCLUDING THE SAME**

AMENDMENT

U.S. Patent and Trademark Office
Customer Window, Mail Stop Amendment
Randolph Building
401 Dulany Street
Alexandria, Virginia 22314

Sir:

In reply to the Office Action of September 22, 2017, please amend the above-identified application as follows:

Amendments to the Claims are reflected in the listing of claims.

Remarks/Arguments begin after the listing of the claims.

AMENDMENTS TO THE CLAIMS

This listing of claims will replace all prior versions, and listings, of claims in the application:

Listing of Claims:

1. (Currently Amended) ~~A receiving antenna of a wireless power receiving device wirelessly charging electric power, the receiving antenna comprising:~~

a substrate;

a soft magnetic layer ~~stacked comprising a first magnetic sheet disposed on the substrate and a second magnetic sheet disposed on the first magnetic sheet;~~

a receiving coil ~~wound in parallel with a plane of the soft magnetic layer, and formed inside of the soft~~ disposed on the second magnetic layer sheet; and

an adhesive layer formed between the ~~soft~~ second magnetic layer sheet and the receiving coil,

wherein the adhesive layer includes a first adhesive layer in contact with the second magnetic sheet, a second adhesive layer in contact with the receiving coil, and an insulating layer disposed between the first adhesive layer and the second adhesive layer, and

wherein a height of a highest position of the second magnetic sheet from the substrate is higher than a height of a lowest position of the receiving coil from the substrate.

2 – 8. (Canceled)

9. (Currently Amended) A method of fabricating a wireless power receiving antenna, the method comprising:

preparing a substrate;

disposing a first soft magnetic sheet including a Fe-Si based alloy on the substrate;

stacking a plurality of the soft magnetic sheets including a soft magnetic metal powder and a polymer resin by stacking a second soft magnetic sheet including the Fe-Si based alloy on the first soft magnetic sheet;

forming disposing an adhesive layer on an upper plane of the plurality of sheets the second soft magnetic sheet;

disposing a receiving coil on the adhesive layer; and

compressing the plurality of the soft magnetic sheets, the adhesive layer, and the receiving coil to form the receiving coil inside of the plurality of sheets,

wherein the adhesive layer includes a first adhesive layer in contact with the second soft magnetic sheet, a second adhesive layer in contact with the receiving coil, and an insulating layer disposed between the first adhesive layer and the second adhesive layer, and

wherein compressing the plurality of the soft magnetic sheets, the adhesive layer, and the receiving coil includes forming a height of a highest position of the second

magnetic sheet from the substrate so to be higher than a height of a lowest position of the receiving coil from the substrate.

10 – 12. (Cancelled)

13. (Currently Amended) A wireless power receiving ~~device~~ apparatus ~~wirelessly charging electric power, comprising a receiving circuit and a wireless power receiving antenna, the wireless power receiving antenna comprising:~~

a substrate;

a soft magnetic layer ~~stacked on the substrate~~ comprising a first magnetic sheet disposed on the substrate and a second magnetic sheet disposed on the first magnetic sheet;

a receiving coil ~~wound in parallel with a plane of the soft magnetic layer, and formed inside of the soft magnetic layer;~~ disposed on the second magnetic sheet, and

an adhesive layer formed between the second soft magnetic layer sheet and the receiving coil;

~~a circuit unit connected to the receiving coil, and configured to convert electromagnetic energy into electrical energy; and~~

~~a storage unit configured to store the electrical energy~~

wherein the adhesive layer includes a first adhesive layer in contact with the second magnetic sheet, a second adhesive layer in contact with the receiving coil, and an insulating layer disposed between the first adhesive layer and the second adhesive layer, and

wherein a height of a highest position of the second magnetic sheet from the substrate is higher than a height of a lowest position of the receiving coil from the substrate.

14 - 22. (Canceled)

23. (New) The wireless power receiving antenna of claim 1, wherein the soft magnetic layer includes an Fe-Si based alloy.

24. (New) The wireless power receiving antenna of claim 23, further comprising a support means stacked on the receiving coil.

25. (New) The wireless power receiving antenna of claim 24, further comprising an NFC coil disposed so as to surround a side portion of the receiving coil.

26. (New) The wireless power receiving antenna of claim 25, wherein the insulating layer includes a polyethylene terephthalate (PET).

27. (New) The wireless power receiving antenna of claim 25, wherein the insulating layer includes a polyimide (PI).

28. (New) The wireless power receiving antenna of claim 25, wherein a portion of the receiving coil is embedded in a portion of the second magnetic sheet.

29. (New) The wireless power receiving antenna of claim 25, wherein a portion of a side of the soft magnetic layer on which the NFC coil is disposed is removed.

30. (New) The wireless power receiving antenna of claim 1, wherein at least one of the first magnetic sheet or the second magnetic sheet includes an Fe-Si based soft magnetic metal powder and a polymer resin.

31. (New) The method of fabricating a wireless power receiving antenna of claim 9, further comprising stacking a support means on the receiving coil.

32. (New) The method of fabricating a wireless power receiving antenna of claim 9, further disposing an NFC coil to surround a side portion of the receiving coil.

33. (New) The method of fabricating a wireless power receiving antenna of claim 32, wherein a portion of a side of the plurality of the soft magnetic sheets on which the NFC coil is disposed is removed.

34. (New) The method of fabricating a wireless power receiving antenna of claim 9, wherein compressing the plurality of the soft magnetic sheets, the adhesive layer, and the receiving coil includes simultaneously compressing the plurality of the soft magnetic sheets, the adhesive layer, and the receiving coil by heating.

35. (New) The method of fabricating a wireless power receiving antenna of claim 34, wherein the insulating layer includes a polyethylene terephthalate (PET).

36. (New) The method of fabricating a wireless power receiving antenna of claim 34, wherein a portion of the receiving coil is formed to be embedded in a portion of the second magnetic sheet.

37. (New) The method of fabricating a wireless power receiving antenna of claim 9, wherein at least one of the first soft magnetic sheet and the second soft magnetic sheet includes an Fe-Si based soft magnetic metal powder and a polymer resin.

Serial No. 14/901,426

Docket No. DANA-0049

Reply to Office Action of September 22, 2017

38. (New) The wireless power receiving apparatus of claim 38, further comprising a NFC coil disposed to surround a side portion of the receiving coil.

REMARKS/ARGUMENTS

Claims 1, 9, 13 and 23-38 are pending in this application. By this Reply, claims 1, 9 and 13 are amended, claims 2-8, 10-12 and 14-22 are canceled, and claims 23-38 are added. Certain amendments are made for purposes of clarity and unrelated to issues of patentability. No new matter is added. Support for the claims can be found throughout the specification, including the original claims and the drawings.

At the outset, the Examiner is thanked for the indication that claims 9-10 and 17-19 are allowed and that claims 2, 5-6 and 20 would be allowable if rewritten in independent form including all of the limitations of the base claim and any intervening claims.

By this Amendment, independent claim 1 is amended to incorporate the allowable features of claim 2. Independent claim 13 is amended to substantially incorporate the allowable features of claim 20. Moreover, independent claim 9 is amended to incorporate similar features.

Specifically, independent claims 1, 9 and 13 are amended to recite "wherein the adhesive layer includes a first adhesive layer in contact with the second magnetic sheet, a second adhesive layer in contact with the receiving coil, and an insulating layer disposed between the first adhesive layer and the second adhesive layer," in combination with other features, respectively. Independent claim 1 is further amended to recite "wherein a height of a highest position of the second magnetic sheet from the substrate is higher than a height of a lowest position of the receiving coil from the substrate." Independent claims 9 and 13

recite similar features in varying scope. The applied prior art fails to teach or suggest these features. Hence, independent claims 1, 9 and 13 should be in condition for allowance, along with dependent claims 23-38 which respectively depend therefrom.

Claim 3 stands objected to for informalities. Moreover, claim 3 stands rejected under 35 U.S.C. §112, second paragraph. Claim 3 is canceled, and hence, this objection and rejection are moot.

Claims 1, 7-8 and 13 stand rejected under 35 U.S.C. §102(a)(1)/(a)(2) as being anticipated by U.S. Patent Publication No. 2013/0069444 to Waffenschmidt et al. (hereinafter “Waffenschmidt”). Claims 3-4, 14-16 and 21-22 stands rejected under 35 U.S.C. §103 as being unpatentable over Waffenschmidt in view of U.S. Patent Publication No. 2009/0121677 to Inoue (hereinafter “Inoue”). The rejections are moot in view of the amendments to independent claims 1, 9 and 13 as previously discussed.

By this Amendment, dependent claims 23-38 are added. It is respectfully submitted that claims 23-38 are allowable by virtue of their dependency on independent claims 1, 9 and 13, respectively, as well as for their added features.

CONCLUSION

In view of the foregoing amendments and remarks, it is respectfully submitted that the application is in condition for allowance. Favorable consideration and prompt allowance are earnestly solicited.

If the Examiner believes that any additional changes would place the application in better condition for allowance, the Examiner is invited to contact the undersigned attorney, **Paul H. Kang**, at the telephone number listed below.

To the extent necessary, a petition for an extension of time under 37 C.F.R. §1.136 is hereby made. Please charge any shortage in fees due in connection with the filing of this, concurrent and future replies, including extension of time fees, to Deposit Account 16-0607 and please credit any excess fees to such deposit account.

Respectfully submitted,
KED & ASSOCIATES, LLP


Paul H. Kang
Registration No. 66545

Correspondence Address:

P.O. Box 8638

Reston, VA 20195

703 766-3777 (main)

703 766-3755 (direct) PHK/seg

Please direct all correspondence to Customer Number 34610

Q:\Documents\2414-049\700842

Docket No.: **DANA-0049**

PATENT

IN THE UNITED STATES PATENT AND TRADEMARK OFFICE

In re Application of

Confirmation No.: **5436**

**Seok BAE; Donchul CHOI; and Soon Young
HYUN**

Group Art Unit: **2859**

Serial No.: **14/901,426**

Examiner: **M. Baye DIAO**

Filed: **December 28, 2015**

Customer No.: **34610**

For: **RECEIVING ANTENNA AND WIRELESS POWER RECEIVING DEVICE
INCLUDING THE SAME**

INFORMATION DISCLOSURE STATEMENT

U.S. Patent and Trademark Office
Customer Service Window
Randolph Building
401 Dulany Street
Alexandria, Virginia 22314

Sir:

Pursuant to 37 C.F.R. §1.56, the attention of the Patent and Trademark Office is hereby directed to the references listed on the attached PTO-1449. One copy of each non-U.S. reference is attached. It is respectfully requested that the information be expressly considered during the prosecution of this application, and that the reference(s) be made of record therein and appear among the "References Cited" on any patent to issue therefrom.

Applicants have listed publication dates on the attached PTO-1449 based on information presently available to the undersigned. However, the listed publication dates should not be construed as an admission that the information was actually published on the indicated date. Applicants reserve the right to establish the patentability of the claimed invention over any of the information provided herewith, and/or to prove that this information may not be prior art, and/or to prove that this information may not be enabling for the teachings purportedly offered. This statement should not be construed as a representation that a search has been made, that information cited in the statement is considered to be and/or is material to patentability, or that information more material to the examination of the present patent application does not exist. The Examiner is specifically requested not to rely solely on the material submitted herewith. It is further understood that the Examiner will consider information that was cited or submitted to the U.S. Patent and Trademark Office in a prior application relied on under 35 U.S.C. §120. 1138 OG 37, 38 (May 19, 1992).

- 1. This Information Disclosure Statement is being filed (i) within three months of the U.S. filing date of a U.S. application other than a CPA continued prosecution application under §1.53(d) OR (ii) within three months of the date of entry of the national stage as set forth in §1.491 in an international application OR (iii) before the mailing date of a first Office Action on the merits OR (iv) before the mailing of a first Office Action after the filing of a Request for continued examination under §1.114. No certification or fee is required. 37 C.F.R. §1.97(b).
- 2. This Information Disclosure Statement is being filed more than three months after the U.S. filing date AND after the mailing date of the first Office Action on the merits, but before the mailing date of a Final Rejection OR Notice of Allowance OR an action that otherwise closes prosecution in the application. 37 C.F.R. §1.97(c).
 - a. I hereby state that each item of information contained in this Information Disclosure Statement was first cited in a communication from a foreign patent office in a counterpart foreign application not more than three months prior to the filing of this Information Disclosure Statement. 37 C.F.R. §1.97(e)(1). No fee is required.
 - b. I hereby state that no item of information in this Information Disclosure Statement was cited in a communication from a foreign patent office in a counterpart foreign application and, to my knowledge after making reasonable inquiry, was known to any

individual designated in 37 C.F.R. §1.56(c) more than three months prior to the filing of this Information Disclosure Statement. 37 C.F.R. §1.97(e)(2). No fee is required.

- c. Please charge our Credit Card in the amount of \$180.00 in payment of the fee under 37 C.F.R. §1.17(p) per the attached PTO 2038 form. Please credit or debit Deposit Account No. 16-0607 as needed to ensure consideration of the disclosed information.
- 3. This Information Disclosure Statement is being filed after the mailing date of a Final Rejection OR Notice of Allowance OR an action that otherwise closes prosecution in the application, but on or before payment of the Issue Fee. Please charge our Credit Card in the amount of \$180.00 in payment of the fee under 37 C.F.R. §1.17(p) per the attached PTO 2038 form. Please credit or debit Deposit Account No. 16-0607 as needed to ensure consideration of the disclosed information. 37 C.F.R. §1.97(d).
 - a. I hereby state that each item of information contained in this Information Disclosure Statement was first cited in a communication from a foreign patent office in a counterpart foreign application not more than three months prior to the filing of this Information Disclosure Statement. 37 C.F.R. §1.97(e)(1).
 - b. I hereby state that no item of information in this Information Disclosure Statement was cited in a communication from a foreign patent office in a counterpart foreign application or, to my knowledge after making reasonable inquiry, was known to any individual designated in 37 C.F.R. §1.56(c) more than three months prior to the filing of this Information Disclosure Statement. 37 C.F.R. §1.97(e)(2).
- 4. The references were cited in a corresponding Chinese Office Action. Please note that the references previously submitted in an Information Disclosure Statement filed on September 30, 2016, are not submitted herewith.
- 5. To the extent necessary, a petition for an extension of time under 37 C.F.R. §1.136 is hereby made. Please charge any shortage in fees due in connection with the filing of this paper, including extension of time fees, to Deposit Account 16-0607 and please credit any excess fees to such deposit account.

Respectfully submitted,
KED & ASSOCIATES, LLP



Paul H Kang
Registration No. 66,545

Correspondence Address:
P.O. Box 8638
Reston, VA 20195
Telephone: (703) 766-3777
PHK/seg

Please direct all correspondence to Customer Number 34610

\\ked2\Documents\2414\2414-049\703072.docx



Espacenet

Bibliographic data: TW200723596 (A) — 2007-06-16

Sheet body for improving communication, antenna device provided with such sheet body and electronic information transmitting apparatus

Inventor(s): GO HARUhide [JP]; YOSHIDA TAKAHIKO [JP]; MATSUSHITA MASATO [JP]; KIYOHARA YOSHIHARU [JP]; SATO SHINICHI [JP]; YOSHIHARA RYOTA [JP]; MORITA KAZUHISA [JP]; KOGURE HIROAKI [JP] ± (GO, HARUhide, ; YOSHIDA, TAKAHIKO, ; MATSUSHITA, MASATO, ; KIYOHARA, YOSHIHARU, ; SATO, SHINICHI, ; YOSHIHARA, RYOTA, ; MORITA, KAZUHISA, ; KOGURE, HIROAKI)

Applicant(s): NITTA CORP [JP] ± (NITTA CORPORATION)

Classification: - international: **G06K19/077; H01Q1/44; H05K9/00**
- cooperative: **H01Q1/526; H01Q15/0026; H01Q17/00; H01Q19/108**

Application number: TW20060139078 20061023

Priority number(s): JP20050307325 20051021

Also published as: EP2096711 (A1) EP2096711 (A4) EP2096711 (B1)
TWI335688 (B) US2010052992 (A1) more

Abstract of TW200723596 (A)

A conductive pattern (22) formed on a pattern layer (15) operates as antenna. When an electromagnetic wave of a prescribed frequency arrives, resonance phenomenon is exhibited, and the electromagnetic wave of a specific frequency is introduced into a sheet body (10). Since the sheet body (10) having the pattern layer (15) can adjust the phase of a reflection wave from a reflection area, even the sheet body is small and thin, and an area having a high electric field intensity can be set in the vicinity of the antenna element by interference of the reflection wave from the sheet body and the coming electromagnetic wave. An electromagnetic field is generated in the periphery of the conductive pattern (22) by arranging the sheet body (10) between the antenna element (51) and the communication disturbing member (57), and electromagnetic energy is supplied from the conductive pattern to the antenna element (51). Thus, receiving power of the antenna element (51) is increased and wireless communication can be suitably performed.

200723596

發明專利說明書

200723596

(本說明書格式、順序及粗體字，請勿任意更動，※記號部分請勿填寫)

※ 申請案號： 9513P078

※ 申請日期： 95.10.23

※IPC 分類：H01Q 1/44 H05K 9/00
G06K 19/077

一、發明名稱：(中文/英文)

通信改善用片體與包含其之天線裝置及電子資訊傳達裝置

二、申請人：(共 1 人)

姓名或名稱：(中文/英文)

日商新田股份有限公司

NITTA CORPORATION

代表人：(中文/英文)

新田 長彥

NITTA, TAKEHIKO

住居所或營業所地址：(中文/英文)

日本國大阪府大阪市浪速區櫻川4丁目4番26號

4-26, SAKURAGAWA 4-CHOME, NANIWA-KU, OSAKA-SHI, OSAKA

556-0022, JAPAN

國 籍：(中文/英文)

日本 JAPAN

200723596

三、發明人：(共 8 人)

姓 名：(中文/英文)

1. 吳 東英
GO, HARUHIDE
2. 吉田 隆彦
YOSHIDA, TAKAHIKO
3. 松下 正人
MATSUSHITA, MASATO
4. 清原 好晴
KIYOHARA, YOSHIHARU
5. 佐藤 真一
SATO, SHINICHI
6. 吉原 良太
YOSHIHARA, RYOTA
7. 森田 和久
MORITA, KAZUHISA
8. 小暮 裕明
KOGURE, HIROAKI

國 籍：(中文/英文)

1. 日本 JAPAN
2. 日本 JAPAN
3. 日本 JAPAN
4. 日本 JAPAN
5. 日本 JAPAN
6. 日本 JAPAN
7. 日本 JAPAN
8. 日本 JAPAN

四、聲明事項：

主張專利法第二十二條第二項 第一款或 第二款規定之事實，其事實發生日期為： 年 月 日。

申請前已向下列國家（地區）申請專利：

【格式請依：受理國家（地區）、申請日、申請案號 順序註記】

有主張專利法第二十七條第一項國際優先權：

1. 日本；2005年10月21日；特願2005-307325

2.

無主張專利法第二十七條第一項國際優先權：

1.

2.

主張專利法第二十九條第一項國內優先權：

【格式請依：申請日、申請案號 順序註記】

主張專利法第三十條生物材料：

須寄存生物材料者：

國內生物材料 【格式請依：寄存機構、日期、號碼 順序註記】

國外生物材料 【格式請依：寄存國家、機構、日期、號碼 順序註記】

不須寄存生物材料者：

所屬技術領域中具有通常知識者易於獲得時，不須寄存。

九、發明說明：

【發明所屬之技術領域】

本發明係關於一種在妨礙通信構件之近旁，使用天線元件而進行無線通信用之通信改善用片體與包含其之天線裝置及電子資訊傳達裝置。

【先前技術】

圖51係簡化先前技術之標籤(Tag)1而顯示之剖面圖。是13.56 MHz頻帶為代表之電磁感應方式之無線通信的情況。RFID(無線頻率識別(Radio Frequency Identification))系統係用於固定之自動識別之系統，且基本上包含：讀取器與轉發器。該RFID系統之轉發器使用標籤1。標籤1包含：檢測磁力線之磁場型天線之線圈天線2，及使用其線圈天線2進行無線通信之積體電路(IC)3。標籤1係構成接收來自讀取器之要求信號時，傳送記憶於IC3內之資訊，換言之，可藉由讀取器而讀取保持於標籤1之資訊。標籤1如貼合於商品而設置，利用於商品管理，以防止商品遭竊及掌握庫存狀況等。

該標籤1貼合於金屬製之商品而使用等，於天線2之近旁存在妨礙通信構件4(本例為導電性材料)時，藉由天線2收發之電磁波之信號而形成之磁場之磁力線，通過妨礙通信構件4之表面近旁。此時，在妨礙通信構件4上產生渦電流，電磁波能轉換成熱能而被吸收。如此，能量被吸收時，電磁波之信號大幅衰減，導致標籤1無法進行無線通信。此外，藉由感應之渦電流產生與標籤之通信用磁場相

反方向之磁場(反磁場)，亦產生消磁現象。標籤1亦由於該現象而無法進行無線通信。再者，由於妨礙通信構件4之影響，亦有天線2之共振頻率偏移之現象。因此，標籤1在妨礙通信構件4之近旁無法使用。

圖52係簡化其他先前技術之標籤1A而顯示之剖面圖。圖52所示之標籤1A與圖51之標籤1類似，在對應之部分註記相同符號，而僅說明不同之構造。圖52之標籤1A為求解決圖51之標籤1的問題，其構造包含磁性吸收板7，其係配置於貼合物品之構件4及天線2之間而設置。具有複數相對磁導率之板的磁性吸收板7係由鐵矽鋁磁合金、鐵氧體及羰基鐵等高磁導率材料，亦即由複數相對磁導率高之材料構成。

複數相對磁導率包含實數部與虛數部，實數部高時，複數相對磁導率提高。換言之，複數相對磁導率高之材料，其複數相對磁導率中之實數部高。磁場中存在複數相對磁導率中實數部高之材料時，磁力線可集中而通過其構件內。使用檢測磁力線之磁場型之天線2的標籤1A，藉由設置磁性吸收板7，防止磁場洩漏於妨礙通信構件4，即使在妨礙通信構件4近旁使用，仍可抑制磁場能量之衰減而進行無線通信。此種標籤1A如專利文獻1中所示。

此外，另外之先前技術係配置於包含金屬等之壁面附近，在可傳送指定電波之非接觸式無線資料載體上，以接合劑等貼合片體，而吸收該片體朝向壁面之電波及藉由壁面而反射之電波，於非接觸式無線資料載體動作時，在有

效之電波區域中，可以全部之空間收發。該例係將藉由 2.4 GHz 頻帶之電波方式之無線通信的 RFID 系統作為對象。此外，藉由接合劑等貼合：非接觸無線資料載體；具有指定厚度，且具有不吸收電波性質之間隔物；及電波反射體；使非接觸無線資料載體之位置，與自電波反射體離開 $\lambda/4$ (λ 表示波長) 程度之位置，與自該位置離開 $n\lambda/2$ (符號 n 係自然數) 之位置不一致地，設定間隔物 δ 之厚度，於非接觸無線資料載體動作時，在有效之電波區域，可以全部之空間收發。使用非接觸無線資料載體之資料載體系統，如專利文獻 2 所示。

[專利文獻 1] 日本特開 2000-114132 號公報

[專利文獻 2] 日本特開 2002-230507 號公報

【發明內容】

[發明所欲解決之問題]

本發明所稱之妨礙通信構件，係藉由存在於天線近旁，比在自由空間時，可使天線之通信特性惡化之構件。妨礙通信構件如相當於：金屬等之導電性材料，玻璃、紙張、液體等之電介質材料，及帶磁性之磁性體材料。在天線元件之近旁存在導電性材料時，天線元件之輸入阻抗顯著降低，造成無線通信困難。此外，瓦楞板、樹脂、玻璃及液體等電介質材料，藉由其具有之介電常數，使天線之共振頻率降低而妨礙無線通信。再者，磁性材料亦藉由磁導率，照樣使天線之共振頻率降低，而妨礙無線通信。

如圖 52 所示之標籤 1A，使用線圈天線等磁場型之天線 2

情況下，藉由防止磁場洩漏，雖可在妨礙通信構件4之近旁進行無線通信，但是，磁場型天線通常存在無法確保充分之通信距離的問題。此外，此種防止磁場洩漏用之構造，於使用檢測電力線之電場型之天線情況下，視同無效，而不檢討採用。

此外，專利文獻2係在非接觸無線資料載體上，經由片體或間隔物而堆疊電波反射體，而使資料載體之位置與自電波反射體離開 $\lambda/4$ 程度之位置及自該位置離開 $n\lambda/2$ (n 係自然數)之位置不一致。該專利文獻2，係在各個自反射面離開 $\lambda/4$ 程度之位置及自該位置離開 $\lambda/2$ 之位置，出現入射波與反射波抵銷而無法收發之點。但是，本發明人發現，如圖12所示，電波經電波反射面反射時，其相位偏移 180° ，結果自電波反射面離開 $\lambda/4$ 程度之位置，藉由干擾而電場強度最強。同時，該位置之磁場強度為零。亦即，雖然磁場型天線無法接收，但是一般使用之電場型天線則顯示最佳之接收。若離開其位置，則有在妨礙通信構件近旁，無法確保充分通信距離之問題。

再者，共振頻率之偏移問題，視存在於近旁之材料(材質)而異，由於其偏移量不定，因而要求個別之通信改善對策(修正共振頻率)。

本發明之目的，在提供一種並非衰減電磁能之電波吸收體，而係在妨礙通信構件近旁可保存通信能，可正常進行無線通信之通信改善用片體與包含其之天線裝置及電子資訊傳達裝置。

[解決問題之手段]

本發明之通信改善用片體之特徵為：包含圖案層，其係在妨礙通信構件之近旁使用天線元件進行無線通信時，設於天線元件與妨礙通信構件之間，並且形成導電性圖案。

按照本發明，圖案層之導電性圖案用作天線，於指定頻率之電磁波到來時發現共振現象。在圖案層之近旁設置偶極天線等之天線元件時，導電性圖案層與天線元件引起電磁耦合，貯存於圖案層之電磁能，自導電性圖案轉移至天線元件。自導電性圖案供給共振頻率之電磁能至天線元件，與不設置圖案層時比較，可增加天線元件之接收電力。因此，即使在妨礙通信構件之近旁仍可正常進行無線通信，並可確保充分之通信距離。如此，藉由包含導電性圖案，片體獨自具有天線功能，可獲得天線元件之通信改善效果。本發明之通信改善用片體，本身不受妨礙通信構件之影響，且設計成其本身不致對天線元件造成不良影響，再者，成為於天線元件中補足用於通信之電磁能之構造體。

此外，本發明之特徵為包含貯藏體層，其係包含非導電性之電介質層及/或磁性體層，並且收集用於無線通信之電磁波能量。

按照本發明，在妨礙通信構件之近旁配置天線元件時，由於在天線元件與妨礙通信構件之間配置收集用於無線通信之電磁波能量之貯藏體層，因此，防止導通，可增加電抗(L)成分及電容(C)成分，此外，藉由複數相對介電常數

之實數部 ϵ' 及 / 或複數相對磁導率之實數部 μ'' ，可彎曲進入片體之電磁波之傳播路徑，再者，藉由波長縮短效應，可使導電性圖案及片體厚度體積小及厚度薄。貯藏體層藉由不具導電性之磁性材料層或介電材料層之至少 1 個而形成。

此外，在妨礙通信構件之近旁配置天線元件時，由於在天線元件與妨礙通信構件之間配置非導電性之貯藏體層，因此可抑制因妨礙通信構件造成天線元件之輸入阻抗降低。輸入阻抗小時，與使用天線元件進行通信之通信機構之阻抗背離，在天線元件與通信機構之間無法收發信號。由於片體可在妨礙通信構件之近旁配置天線元件時，抑制天線元件之輸入阻抗降低，因此，即使在妨礙通信構件之近旁，仍可正常進行無線通信。

此外，本發明之特徵為：進一步包含反射區域形成層，其係在與圖案層之間夾著貯藏體層，自圖案層隔以間隔而設於與天線元件相反側，將用於無線通信之電磁波之波長設為 λ 時，在自圖案層起電性長度為 $((2n-1)/4)\lambda$ (n 為正整數) 之位置附近，形成反射用於無線通信之電磁波之反射區域。

按照本發明，藉由共振而將特定頻率之電磁波取入片體內部，在片體內部調整取入之電磁波的相位，用於無線通信之電磁波之波長為 λ 時，可使形成於自反射區域起離開電性長度為 $((2n-1)/4)\lambda$ (n 為正整數) 之位置之電場強度變強之區域產生於圖案層之位置。藉由反射區域形成層而形成

之反射區域所反射之電磁波，由於其相位變位 180° ，因此，到來之電磁波與被反射區域所反射之電磁波干擾時，自反射區域起電性長度為電磁波之波長之 $((2n-1)/4)$ 倍中，電場強度提高。藉由在反射之電磁波與到來之電磁波強力結合而干擾之位置設置天線元件，亦即，藉由在天線元件上，以電性絕緣狀態而近旁地配置圖案層來使用，可防止可藉由天線元件接收之電場強度降低，即使在妨礙通信構件之近旁，仍可正常地進行無線通信。此外，反射區域可為反射區域形成層本身，或是亦可為虛擬連結導電性圖案之中央附近與反射區域形成層之電場為零之位置(虛擬之電磁波反射面)。反射區域為虛擬連結導電性圖案之中央附近與反射區域形成層之電場為零之位置(虛擬之電磁波反射面)時，利用在該位置電磁波反射與電磁波繞進導電性圖案，可爭取自導電性圖案至反射區域之電性長度。因而可使片體厚度比 $((2n-1)/4)\lambda$ (n 為正整數)小，而可實現薄型化。

此外，藉由設置反射區域形成層，可防止受到片體設置位置之影響，亦即，可防止因構成妨礙通信構件之材料種類及附著於妨礙通信構件表面之水等液體存在，導致導電性圖案之共振頻率變化。藉此，各個不同之天線元件無須再度調整通信之最佳條件，而可使天線元件之通信條件穩定化。

此外，本發明之特徵為：圖案層係形成彼此電性絕緣之複數導電性圖案。

按照本發明，藉由圖案層，可接收對應於各導電性圖案尺寸之電磁波，而發現共振現象。藉由導電性圖案尺寸之決定方法，可藉由用於無線通信之電磁波增加天線元件獲得之電力。此時，與通信頻率之電磁波共振之圖案可為單數亦可為複數。圖案層亦可為單層或數層。亦可立體地形成。

此外，本發明之特徵為：圖案層係形成尺寸及形狀中之至少任一方不同之複數種導電性圖案。

按照本發明，尺寸及形狀中之至少任一方不同之複數種導電性圖案，其各個共振頻率不同，因此，可以圖案層接收數種頻率之電磁波。此外，可藉由用於無線通信之電磁波，而確實增加天線元件獲得之電力。

此外，本發明之特徵為：圖案層係形成涵蓋片體之寬廣範圍而連續延伸之導電性圖案。

按照本發明，由於形成涵蓋寬廣範圍而連續構成之導電性圖案之圖案層，可涵蓋寬廣帶域之頻率提高增益，因此，包含其之片體可接收寬廣帶域頻率之電磁波。此外，藉由用於無線通信之電磁波，可確實增加天線元件獲得之電力。

此外，本發明之特徵為：導電性圖案具有至少1個角部係曲線狀之大致多角形之外輪廓形狀。

接收電磁波之導電性圖案，具有基本上係多角形之大致多角形之外輪廓形狀，且至少1個角部形成曲線狀。藉由在角部賦予R，亦即藉由形成曲線狀，可抑制而減少依電

磁波之偏振方向，增益達到峰值之頻率的偏差，而形成良好之偏振特性。因此，可實現增益之峰值提高，且依電磁波之偏振方向，增益達到峰值之頻率偏差小之優異的通信改善用片體。

圖案層之構造亦可全部導電性圖案具有曲線狀之角部，亦可並非全部之導電性圖案具有曲線狀角部之構造，只要是一部分之導電性圖案具有曲線狀之角部的構造即可。一部分導電性圖案具有曲線狀之角部情況下，其他之導電性圖案並非就有無曲線狀之角部而限定者。再者，具有曲線狀角部之導電性圖案亦可為僅一部分角部係曲線狀，亦可為全部之角部為曲線狀。此外，導電性圖案亦可為大致多角形之面狀形狀，亦可為延伸成大致多角形狀之封閉迴路之線狀形狀。如此，藉由用於無線通信之電磁波，可確實增加天線元件獲得之電力。

此外，本發明之特徵為：圖案層係形成複數導電性圖案，並組合角部之曲率半徑不同之導電性圖案而形成。

按照本發明，藉由形成角部之曲率半徑不同之導電性圖案，對於僅形成角部之曲率半徑相同之導電性圖案時，不降低增益之峰值，而可變更接收之電磁波之頻率帶域(以下，有時稱為「接收帶域」)。接收帶域之變更包含：擴大接收帶域及接收頻率之變更。如藉由在鄰接之導電性圖案之角部曲率半徑上賦予若干差異，不降低增益之峰值，而可擴大接收帶域，此外，如藉由在鄰接之導電性圖案之角部曲率半徑上賦予稍大之差異，不降低增益之峰值，而

可將接收之電磁波之頻率(以下，有時稱為「接收頻率」)向低的方向擴大。

此外，本發明之特徵為：圖案層係形成複數導電性圖案，鄰接之2個導電性圖案之間隔依位置而不同。

按照本發明，比將鄰接之2個導電性圖案之間隔保持一定時，可擴大增益。

此外，本發明之特徵為：用於無線通信之電磁波頻率包含於300 MHz以上300 GHz以下之範圍。

按照本發明，可使用頻率為300 MHz以上，300 GHz以下之電磁波正常地進行無線通信。在300 MHz以上，300 GHz以下之範圍中，包含UHF頻帶(300 MHz~3 GHz)、SHF頻帶(3 GHz~30 GHz)及EHF頻帶(30 GHz~300 GHz)。

此外，本發明之特徵為：總厚度為50 mm以下。

按照本發明，可減少厚度而達到可使用頻率為300 MHz以上300 GHz以下範圍中包含之頻率之電磁波而正常進行無線通信用之片體厚度，而達到薄型化。

此外，本發明之特徵為：用於無線通信之電磁波頻率包含於860 MHz頻帶以上1,000 MHz頻帶以下之任一頻帶(以下，稱為高MHz頻帶)，且總厚度為15 mm以下。

按照本發明，可減少厚度而達到可使用頻率包含於高MHz頻帶之頻率之電磁波而正常進行無線通信用之片體厚度，而達到薄型化。

此外，本發明之特徵為：用於無線通信之電磁波頻率包含於2.4 GHz頻帶，總厚度為8 mm以下。

按照本發明，可減少厚度而達到可使用頻率包含於2.4 GHz頻帶之頻率之電磁波而正常進行無線通信用之片體厚度，而達到薄型化。

此外，本發明之特徵為：貯藏體層係包含對有機聚合物100重量份，作為磁性材料，以1重量份以上1500重量份以下之添加量包含選自鐵氧體、鐵合金及鐵粒子之群中之1個或複數材料之材料。

按照本發明，可在貯藏體層中賦予複數相對磁導率(μ' 、 μ'')，可適切實現達成前述效果之片體。

此外，本發明之特徵為：係賦予難燃性。

按照本發明，片體具有難燃性。如使用包含標籤、讀取器、行動電話之天線元件進行無線通信之電子資訊傳達裝置，有時要求難燃性。片體亦可適用於要求此種難燃性之用途上。

此外，本發明之特徵為：至少一方之表面部具有黏合性或接合性。

按照本發明，由於至少一方表面部具有黏合性或接合性，因此，如前述妨礙通信構件等可黏合於其他物品上。藉此，可輕易使用片體。

此外，本發明之天線裝置之特徵為包含：天線元件，其係具有配合用於無線通信之頻率之共振頻率；及

前述通信改善用片體。

按照本發明，片體係設於天線元件與妨礙通信構件之間。藉此，可使用天線裝置，設於妨礙通信構件之近旁，

使用天線元件正常進行無線通信，而傳達電子資訊。如此，可實現可在妨礙通信構件近旁正常使用之天線裝置。

此外，本發明之電子資訊傳達裝置之特徵為：包含前述天線裝置。

按照本發明，可實現即使設於妨礙通信構件之近旁，仍可使用包含天線元件之天線裝置正常進行無線通信之電子資訊傳達裝置。

[發明之效果]

本發明藉由將通信改善用片體設置於天線元件與妨礙通信構件之間，在天線元件上，以電性絕緣狀態而在近旁配置圖案層來使用，引起導電性圖案與天線元件之電磁耦合，電磁能自導電性圖案轉移至天線元件，而將共振頻率之電磁能自導電性圖案供給至天線元件。因此，即使在妨礙通信構件之近旁，仍可正常進行無線通信，並可確保充分之通信距離。

此外，本發明將天線元件配置於妨礙通信構件之近旁時，由於在天線元件與妨礙通信構件之間配置收集用於無線通信之電磁波能量之貯藏體層，因此防止導通，可增加電抗(L)成分及電容(C)成分，此外可藉由複數相對介電常數之實數部 ϵ' 及/或複數相對磁導率之實數部 μ' ，彎曲進入片體之電磁波之傳播路徑，再者可藉由波長縮短效應而達到小型化。

此外，本發明藉由反射區域形成層形成反射區域，雖是體積小且厚度薄之片體，但是調整來自反射區域之反射波

之相位，藉由來自反射區域之反射波與到來之電磁波之干擾，可在片體表面及/或天線元件近旁設定電場強度高之區域。此外，將天線元件配置於妨礙通信構件之近旁時，由於可抑制因妨礙通信構件造成天線元件之輸入阻抗降低，因此即使在妨礙通信構件之近旁，仍可正常進行無線通信。

藉由設置反射區域形成層，可防止因各個妨礙通信構件之材料(材質)造成天線元件之通信條件改變，即使在任何環境下，均可使天線元件之通信條件穩定化。

此外，本發明藉由圖案層，接收對應於各導電性圖案尺寸之電磁波，可發現共振現象。依導電性圖案之尺寸之決定方法，可藉由用於無線通信之電磁波而增加天線元件獲得之電力。

此外，本發明由於尺寸及形狀中之至少任何一方不同之數種導電性圖案之各個共振頻路不同，因此可以圖案層接收數種頻率之電磁波。此外，可藉由用於無線通信之電磁波，而確實增加天線元件獲得之電力。

此外，本發明由於形成涵蓋寬廣範圍而連續構成之導電性圖案之圖案層，可涵蓋寬廣帶域之頻率而提高增益，因此，包含其之片體可接收寬廣帶域之頻率或數種頻率帶之電磁波。此外，可藉由用於無線通信之電磁波而確實增加天線元件獲得之電力。

此外，本發明由於接收電磁波之導電性圖案具有基本上為多角形之大致多角形之外輪廓形狀，且至少1個角部形

成曲線狀，因此，可實現增益之峰值高，且依電磁波之偏振方向，增益達到峰值之頻率的偏差小，而優異之通信改善用片體。

此外，本發明藉由形成角部之曲率半徑不同之導電性圖案，對於僅形成角部之曲率半徑相同之導電性圖案時，不降低增益之峰值，而可變更接收之電磁波之頻率帶域(以下，有時稱為「接收帶域」)。

此外，本發明比鄰接之2個導電性圖案之間隔保持一定時，可擴大增益。

此外，本發明可使用頻率為300 MHz以上，300 GHz以下之電磁波正常進行無線通信。

此外，本發明可減少厚度而達到可使用頻率為300 MHz以上，300 GHz以下範圍中包含之頻率之電磁波而正常進行無線通信用之片體厚度，而達到薄型化。

此外，本發明可減少厚度而達到可使用頻率包含於高MHz頻帶之頻率之電磁波而正常進行無線通信用之片體厚度，而達到薄型化。

此外，本發明可減少厚度而達到可使用頻率包含於2.4 GHz頻帶之頻率之電磁波而正常進行無線通信用之片體厚度，而達到薄型化。

此外，本發明由於貯藏體層係由對有機聚合物100重量部，其磁性材料係以1重量部以上，1500重量部以下之配合量，包含自鐵氧體、鐵合金及鐵粒子之群中選出之1個或複數材料之材料而構成，因此可適切實現達成前述效果

之片體。

此外，本發明之片體具有難燃性，而可適用於要求難燃性之用途上。

此外，本發明由於至少一方表面部具有黏合性或接合性，因此，可黏合於其他物品上。藉此，可輕易使用片體。

此外，本發明可實現設置片體，可設於妨礙通信構件之近旁，而適合用於無線通信之天線裝置。

此外，本發明可實現即使設於妨礙通信構件之近旁，仍可正常進行無線通信之電子資訊傳達裝置。

【實施方式】

圖1係本發明一種實施形態之通信改善用片體(以下稱片體)10之剖面圖。片體10係在妨礙通信構件之近旁，使用天線元件而正常進行無線通信用之片，且設於天線元件與妨礙通信構件之間。

該片體10係片狀，且包含：圖案層15、第一貯藏體層14、反射區域形成層12及貼合層11。片體10進一步包含第二貯藏體層13。各層11~15在圖1中係自上方側之厚度方向(疊層方向)一方側之電磁波入射側，依序堆疊：圖案層15、第一貯藏體層14、第二貯藏體層13、反射區域形成層12及貼合層11，並藉由該疊層構造而構成片體10。在圖案層15之電磁波入射側(圖1之上方)，亦可進一步形成並非反射電磁波之層之表面層16。以下，為了容易瞭解，有時將各貯藏體層14, 13稱為貯藏體層。

本實施形態中，片體10之必要構成要素係：圖案層15、貯藏體層及反射區域形成層12。但是，反射區域形成層12連接於具有其功能之電磁波反射材料(如金屬)而使用時，亦可不包含於片體10中。圖案層15形成起作用作為天線功能之導電性圖案22。貯藏體層係包含非導電性之電介質層及/或磁性體層之層，且由包含：複數相對介電常數之實數部 ϵ' 及/或複數相對磁導率之實數部 μ' ，而儘量抑制各個損失成分之複數相對介電常數之虛數部 ϵ'' 及/或複數相對磁導率之虛數部 μ'' 為較低之材料而構成。貯藏體層位於圖案層15之近旁，可藉由其複數相對介電常數之實數部 ϵ' 及/或複數相對磁導率之實數部 μ' ，彎曲進入片體10之電磁波之傳播路徑，並可藉由波長縮短效應，而使導電性圖案22及片體10之厚度小型化及薄型化。片體10之複數相對介電常數之實數部 ϵ' 之範圍，於通信頻率帶中係1~200，複數相對磁導率之實數部 μ' 之範圍於通信頻率帶中為1~100。並宜在接近導電性圖案22之處設置高 ϵ' 及/或高 μ' 之材料，如此容易獲得波長縮短效應。該貯藏體層可為單層，亦可為多層，亦可為含有空氣層之構造。如貯藏體層(電介質層)可使用發泡體、樹脂、紙、接合劑、黏合劑等，片體10如可為以：圖案層15、接合劑層(高介電常數)、發泡體層(低損失)及反射區域形成層12之方式堆疊之構造。此因，愈在圖案層15之近旁，愈容易獲得來自貯藏體層之波長縮短效應，而使用配合介電材料等之接合材料，確保導電性圖案22與反射區域形成層12之距離時，使用低損失之介電材

料，達到輕量化及低價格化，並進行通信改善之構造。該接合材料層及發泡體層形成本發明中所稱之貯藏體層。當然，並不限定於該構造，亦可組合各種材料。

圖1所示之構造，貯藏體層係包含第一及第二貯藏體層14, 13之構造。貯藏材料包含：包含介電性材料之介電性材(以下，有時稱為「介電材」)及包含磁性材料之磁性材。第一及第二貯藏體層14, 13由包含複數相對磁導率(μ' , μ'')之磁性材及包含複數相對介電常數(ϵ' , ϵ'')之介電材之至少任何一方之材料而構成，亦可均為磁性材或均為介電材，亦可任何一方為介電性材，且任何之另一方係磁性材。此外，僅使用亦可為介電材或磁性材之第一貯藏體層14，而不設置第二貯藏體層13之構造亦包含於本發明。本實施形態之第一貯藏體層14係磁性材，第二貯藏體層13係介電材。

反射區域形成層12係在與第二貯藏體層13之電磁波入射側之相反側的表面上，涵蓋全面形成導電性膜而構成，藉由堆疊於片體10之後述之標籤本體54而反射用於無線通信之電磁波。貼合層11具有黏合性或接合性，係由將片體10貼合於物品用之貼合材構成之層。貼合材包含黏合劑及接合劑之至少一種，藉由黏合性或接合性而具有結合力。貼合層11並非必要，亦可沒有。為形成一體者時，其構造不拘。

為求經由天線元件正常地進行無線通信，將本片體10作為對象之電磁波係依用途而決定者，如為包含於高MHz頻

帶之頻率的電磁波，更具體而言，在日本國內係包含於950 MHz以上，956 MHz以下範圍之頻率的電磁波。作為前述對象之電磁波之頻率係例示，即使是將例示之頻率以外頻率之電磁波作為對象之構造，亦包含於本發明。

此外，本片體10有時用於藉由2.4 GHz頻帶之頻率的電磁波正常進行無線通信。2.4 GHz頻帶係2400 MHz以上，而未達2500 MHz之頻率範圍。RFID系統使用之電磁波，包含於2400 MHz以上，2483.5 MHz以下之範圍。

作為前述對象之電磁波之頻率並非特別限定者，包含300 MHz以上，300 GHz以下之範圍，可選擇任意之單數或複數之頻率。在該300 MHz以上，300 GHz以下之範圍中包含：UHF頻帶(300 MHz~3 GHz)、SHF頻帶(3 GHz~30 GHz)及EHF頻帶(30 GHz~300 GHz)。

各層11~15之厚度尺寸及片體10全部之厚度尺寸並非特別限定者，舉例而言，本實施形態係形成圖案層15之厚度尺寸為 100\AA ($1\times 10^{-8}\text{m}$)以上，500 μm 以下，第一貯藏體層14之厚度尺寸為1 μm 以上，5 mm以下，第二貯藏體層13之厚度尺寸為1 μm 以上，45 mm以下，反射區域形成層12之厚度尺寸為 100\AA ($1\times 10^{-8}\text{m}$)以上，500 μm 以下，貼合層11為1 μm 以上，1 mm以下，片體10全體之厚度尺寸為3 μm 以上，50 mm以下，每單位面積之質量為 0.1 kg/m^2 以上， 40 kg/m^2 以下之片狀。片體10之全體厚度尺寸如前述地小，且各層13~16由前述之材料構成，而具有撓曲性。因此，片體10可隨意變形。

用於高MHz頻帶之無線通信情況下，片體10之全體厚度為0.1 mm以上，15 mm以下，用於2.4 GHz頻帶之無線通信情況下，片體10之全體厚度形成0.1 mm以上，8 mm以下。藉由形成此種構造，可減少厚度而達到可使用頻率為包含於高MHz頻帶或2.4 GHz頻帶之頻率的電磁波正常進行無線通信之片體10的厚度，而可達到薄型化。

本實施形態之第一貯藏體層14藉由選擇包含複數相對磁導率 μ 及複數相對介電常數 ϵ 之材料特性值，收集用於無線通信之電磁波。複數相對磁導率之實數部 μ' 愈大，磁力線愈集中通過，而可彎曲電磁波之傳播路徑。複數相對磁導率之虛數部 μ'' 及磁導率損失項 $\tan\delta\mu(=\mu''/\mu')$ 愈小，磁場能量之損失愈小。因此，複數相對磁導率之實數部 μ' 宜較大，複數相對磁導率之虛數部 μ'' 及磁導率損失項 $\tan\delta\mu$ 宜較小。藉由磁性體之波長縮短效應，而縮小導電性圖案之尺寸及圖案層與反射區域形成層之距離。此外，藉由電介質之波長縮短效應及沿著圖案之電磁波之路徑，而將相當於 $\lambda/4$ (2.4 GHz時約為3 cm)之距離縮短為約1 mm~約8 mm(2.4 GHz頻帶時)。此時，亦與在空間中之 $\lambda/4$ 實質相同，而可包含於本發明中所稱之 $\lambda/4$ 。此外，複數相對介電常數之實數部 ϵ' 愈大，電力線愈集中而通過，而可彎曲電磁波之傳播路徑，複數相對介電常數之虛數部 ϵ'' 愈小，電場能量之損失愈小。因此，複數相對介電常數之實數部 ϵ' 宜較大，此外，複數相對介電常數之虛數部 ϵ'' 宜較小。貯藏體層並非謀求能量損失，而係謀求集中收集能量，而以不損

失之形態通過。該貯藏體層中損失宜較小之性質，係本發明之片體10與電磁波吸收體不同之處。

此外，本發明中，複數相對磁導率之實數部 μ' 及虛數部 μ'' 以及複數相對介電常數之實數部 ϵ' 及虛數部 ϵ'' 之數值，係對應於用於無線通信之電磁波頻率之數值。用於無線通信之電磁波頻率如前述，亦可為包含UHF頻帶、SHF頻帶及EHF頻帶之300 MHz以上，300 GHz以下之範圍，如亦可為高MHz頻帶或2.4 GHz頻帶。

圖2係放大第一貯藏體層14之內部構造而顯示之剖面圖。圖2中，為了容易瞭解，係省略磁性粉末18及磁性微粒子19之陰影線而顯示。第一貯藏體層14為了獲得如前述之材料特性值，在結合材17上混合：包含具有磁性材料之粉末(以下，稱為「磁性粉末」)18與包含具有磁性材料之微粒子(以下，稱為「磁性微粒子」)19而形成。第一貯藏體層14之磁性材料含有磁性粉末18及磁性微粒子19。圖2係例示，而並不限定於此。本實施形態之結合材17包含聚合物，如包含非鹵素系聚合物，或混合非鹵素系聚合物與其他聚合物等之材料之非鹵素系混合材料。

結合材17亦可使用鹵素系聚合物。關於結合材17，如聚合物(樹脂、TPE、橡膠)凝膠、低聚物等，不論是有機系或無機系，此外，不取決於聚合度等可使用所有材質之材料。非鹵素系之材料係從環境觀點適合使用者。為求形成片，宜採用聚合材料，如宜使用以下列舉者，不過未列舉之種類的材料、刮片材料及合金化之材料等，凡是可形成

片之材料全部均可使用。

結合劑 20 之材料可使用各種有機聚合物材料，如包含：橡膠、熱可塑性彈性體及各種塑膠之高分子材料等。前述橡膠除天然橡膠之外，如有：異戊二烯橡膠、丁二烯橡膠、苯乙烯-丁二烯橡膠、乙二醇-丙烯橡膠、乙二醇-乙酸乙烯基系橡膠、丁基橡膠、氯丁二烯橡膠、硝基橡膠、丙烯基橡膠、乙二醇丙烯基系橡膠、環氧氯丙烷橡膠、氟橡膠、聚氨酯橡膠、矽橡膠、氯化聚乙烯橡膠及加氫硝基橡膠 (HNBR) 等合成橡膠單獨、此等之衍生物、或將此等以各種變性處理而改質者等。

此等橡膠除了單獨使用外，亦可混合數種而使用。橡膠中，除加硫劑之外，可適切配合加硫促進劑、防老化劑、軟化劑、可塑劑、填充劑及著色劑等先前用作橡膠配合劑者。除此等之外，亦可使用任意之添加劑。如為了控制介電常數及導電率，進行材料設計而添加指定量之電介質 (碳黑、黑鉛、氧化鈦等)。再者，亦可適切選擇而添加加工輔助劑 (滑劑、分散劑)。

熱可塑性彈性體如為：氯化聚乙烯等氯系、乙烯系共聚合物、丙烯基系、乙烯丙烯基共聚合物系、聚氨酯系、酯系、矽系、苯乙烯系、醯胺基系等各種熱可塑性彈性體及此等之衍生物。

再者，各種塑膠如為：聚乙烯、具丙烯、AS 樹脂、ABS 樹脂、聚苯乙烯、聚氯乙烯、聚偏氯乙烯等氯系樹脂、聚乙酸乙烯、乙二醇-乙酸乙烯共聚合物、氟樹脂、矽樹

脂、丙烯酸系樹脂、尼龍、聚碳酸酯、聚對苯二甲酸乙二醇酯、醇酸樹脂、不飽和聚酯、聚砜、聚二苯硫化物樹脂、液晶聚合物、聚醯胺亞胺樹脂、聚氨基酯樹脂、苯酚樹脂、尿素樹脂、環氧樹脂、聚醯亞胺樹脂等熱可塑性樹脂或熱硬化性樹脂及此等之衍生物。此等之結合劑可使用低分子量之低聚物型及液狀型者。如為藉由熱、壓力、紫外線、硬化劑等成型後，而形成片狀者，可選擇任意之材料。除此等之外，亦可使用陶瓷、紙、黏土等有機物質、無機物質之一切材料。

磁性粉末18係扁平之軟磁性金屬粉末，彼此不接觸而分散，且配向成對第一貯藏體層14之厚度方向垂直地延伸。磁性粉末18係大致圓板狀，平均厚度尺寸係2 μm ，垂直於厚度方向之方向的平均外徑係55 μm 。磁性微粒子19係厚度尺寸比金屬粉末小之微粒子，至少外表面部全體具有非導電性，而構成導電性降低。磁性微粒子19之平均外徑係1 μm 。

形成第一貯藏體層14之結合材17，如使用添加氫之NBR橡膠之HNBR。此外，磁性粉末18如包含鐵、矽及鋁合金(鐵-矽-鋁)之鐵矽鋁磁性合金。此外，磁性微粒子包含抑制全體之導電性而具有耐腐蝕性之如氧化鐵(磁鐵礦)。前述之尺寸及材料不過是例示，並不限定於此。

第一貯藏體層14只要係具有適切之複數相對磁導率及複數相對介電常數者，其材料構成並無特別限定。如本實施例所示，亦可使軟磁性粉末18及/或磁性微粒子19分散於

結合材 17 中，亦可直接使用磁性體(金屬氧化物、陶瓷、粒狀體 (granular) 薄膜、鐵氧體電鍍等)作為第一貯藏體層 14。軟磁性粉末 18 及 / 或磁性微粒子 19 之軟磁性粉末如為：鐵矽鋁磁性合金(鐵-矽-鋁合金)、坡莫合金(鐵-鎳合金)、矽鋼(鐵-銅-矽合金)、鐵-矽合金、鐵-矽-硼(-銅-鈮)合金、鐵-鎳-鉻-矽合金、鐵-鉻-矽合金、鐵-鋁-鎳-鉻合金、鐵-鎳-鉻合金、鐵-鉻-鋁-矽合金等。此外，亦可使用鐵氧體或純鐵粒子。鐵氧體如為：錳-鋅鐵氧體、鎳-鋅鐵氧體、錳-鎂鐵氧體、錳鐵氧體、銅-鋅鐵氧體、銅-鎂-鋅鐵氧體等軟鐵氧體，或是永久磁石材料之硬鐵氧體。純鐵粒子如為羰基鐵等。並宜使用磁導率高之扁平軟磁性粉末。除了以單體使用此等磁性材料外，亦可混合數種。軟磁性粉末亦可使用扁平軟磁性粉末與非扁平軟磁性粉末(針狀、纖維狀、球狀、塊狀等)之組合，不過，組合之至少一種宜為扁平狀。軟磁性粉末之粒徑為 0.1 μm 以上，1000 μm 以下並宜為 10 μm 以上，300 μm 以下者。此外，扁平軟磁性粉末之縱橫尺寸比為 2 以上，500 以下，並宜為 10 以上，100 以下者。軟磁性粉末，為求使其表面提高耐腐蝕性，亦可包含氧化覆膜。磁性粉末之表面宜實施表面處理。表面處理劑可使用耦合劑及界面活性劑等之一般處理法。此外，可使用提高磁性粉末與結合材之浸潤性之全部手段(樹脂覆膜、分散劑等)。

第一貯藏體層 14 之磁性材係包含軟磁性金屬、軟磁性氧化金屬、磁性金屬及磁性氧化金屬中之至少任何一種之材

料，並由含有其之材料而構成。第一貯藏體層 14 亦可為使包含軟磁性金屬、軟磁性氧化金屬、磁性金屬及磁性氧化金屬中之至少任何一種之粉末及微粒子之至少一方，如前述地分散於結合材 17 之構造，亦可藉由軟磁性金屬、軟磁性氧化金屬、磁性金屬及磁性氧化金屬中之至少任何一種而形成於包含薄膜之膜中。第一貯藏體層 14 中如亦可直接使用具有磁性之陶瓷(鐵氧體等)。

使磁性材料分散於結合材 17 之構造的第一貯藏體層 14，係由對於作為結合材 17 之有機聚合物 100 重量部，以 1 重量部以上，1500 重量部以下之配合量含有磁性材料之自鐵氧體、鐵合金及鐵粒子之群中選出之 1 種或數種材料之材料而形成。磁性材料對有機聚合物 100 重量部之配合量，宜為 10 重量部以上，1000 重量部以下。磁性材料對有機聚合物 100 重量部之配合量未達 1 重量部時，無法獲得充分之磁導率，超過 1500 重量部時，加工性差，而無法製造片體 10，或是製造困難。

第一貯藏體層 14 之構造相同時，複數相對磁導率之實數部 μ' 及虛數部 μ'' ，依對象之電磁波頻率而異，並具有隨著對象之電磁波頻率提高，而變小之傾向。本實施形態中，作為對象之電磁波包含高 MHz 頻帶及 2.4 GHz 頻帶之電磁波。複數相對磁導率之實數部 μ' 及虛數部 μ'' 具有隨著對象之電磁波頻率提高，而變小之傾向。因此，為了形成包含高 MHz 頻帶及 2.4 GHz 頻帶之電磁波而集中通過之構造，如與集中 1 以上 10 MHz 頻帶以下程度之低頻率電磁波而通

過為目的的構造比較，整體而言，複數相對磁導率之實數部 μ' 及虛數部 μ'' ，特別是實數部 μ' 變小。

為了增大第一貯藏體層14中之複數相對磁導率之實數部 μ' ，需要增加第一貯藏體層14中由具有磁性之材料構成部分之量。此外，為了減少複數相對磁導率之虛數部 μ'' ，只須減少磁力線之路徑20上由非磁性材料構成之部分即可。單純地考慮時，增加第一貯藏體層14中之磁性粉末18之配合量時，可增加由具有磁性之材料構成部分之量，並可減少磁力線之路徑上之由非磁性材料構成部分，不過，磁性粉末18之配合量過多，如各導電性磁性粉末18接觸時，造成第一貯藏體層14具有導電性，而在第一貯藏體層14內產生電流，結果產生導電性圖案與反射區域形成層之導通，而損害作為接收電磁波之天線之性能。因此，不可單純地增加磁性粉末18之配合量。

本實施形態藉由混合磁性粉末18與磁性微粒子19，防止磁性粉末18彼此接觸，且可使各磁性粉末18間介有磁性微粒子19，可增加由具有磁性之材料構成部分之量，並且減少磁力線之路徑25上由非磁性材料構成之部分。因此，對高MHz頻帶及2.4 GHz頻帶之電磁波，可獲得如前述之複數相對磁導率 μ 。

此外，本發明其他實施形態之第一貯藏體層14，為了提高磁性材料之填充率，係將成為平均粒子徑比約4:1之大小之兩種磁性粒子，混合於與前述相同之結合材17中，而混合磁性微粒子及軟磁性金屬纖維。再者，為了確保電絕

緣性，而混合電絕緣性微粒子。前述兩種磁性粒子包含與前述磁性粉末18相同之材料，大的一方之平均粒子徑約為20 μm ，小的一方之平均粒子徑約為5 μm 。此外，磁性微粒子及軟磁性金屬纖維包含鐵系材料，磁性微粒子之平均粒徑及軟磁性金屬纖維之平均纖維徑約為1 μm 。電絕緣性微粒子包含氧化矽(SiO_2)，平均粒子徑約為10 nm。再者，為了儘量消除第一貯藏體層14內之空隙，第一貯藏體層14之實測比重值，取儘量接近於來自配合之理論比重值來設計、製造。即使變成圖2所示之構造，而係如前述之構造，同樣地，複數相對磁導率之虛數部 μ'' 成為峰值之共鳴頻率向高頻率側偏移，再者，藉由提高為5 GHz及10 GHz，不致造成在300 MHz以上，特別是高MHz頻帶及2.4 GHz頻帶之複數相對磁導率之實數部 μ' 變大，且複數相對磁導率之虛數部 μ'' 過大，而可實現第一貯藏體層14。

第二貯藏體層13亦可使用與第一貯藏體層14相同之材料，依其用途，只要是氯乙烯樹脂、三聚氰胺、聚酯樹脂、聚氨酯樹脂、木材、石膏、水泥、陶瓷、不織布、發泡樹脂、發泡體、隔熱材、包含耐燃紙之紙及玻璃布等不具導電性之介電材料，均可使用。當然，亦可適切配合介電材及磁性材。第二貯藏體層13之複數相對介電常數之實數部 ϵ' 在1以上50以下之範圍內作選擇。形成該構造時，可任意控制第二貯藏體層13及片體10之介電常數，而有助於導電性圖案22之小型化及片體10之薄型化。

片體10，其至少一方之表面部具有黏合性或接合性。本

實施形態如前述，具有貼合層11，藉此，於厚度方向之另一方側的表面部具有黏合性或接合性。片體10藉由貼合層11之黏合性或接合性的結合力，可貼合於物品上。因此，片體10如藉由貼合於妨礙通信構件57上，而可輕易地設於天線元件51與妨礙通信構件57之間。片體10之厚度方向的一方側配置於天線元件51，厚度方向另一方側配置於妨礙通信構件57側而設置。實現貼合層11之貼合材如使用日東電工社製No.5000 NS。

反射區域形成層12可為：金、白金、銀、鎳、鉻、鋁、銅、鋅、鉛、鎢、鐵等金屬，亦可為在樹脂中混入上述金屬之粉末、導電性碳黑之樹脂混合物、熟知之導電性墨或導電性樹脂之膜等。亦可為上述金屬等加工成板、片、膜、不織布、布等者。亦可為ITO及ZnO等之導電性氧化物。此外，亦可為組合金屬箔與玻璃布之形態。或是，亦可具有在合成樹脂性膜上形成有膜厚如為600Å之金屬層之構造。此外，亦可為將導電墨(導電率為5,000 S/m以上)塗布於基板上之構造。亦可為反射特定頻率之電磁波之篩網、圖案狀之構造。

使用上述反射區域形成層12之構成材料，可形成圖案層15之導電性圖案22。各導電性圖案22如包含銀、鋁等金屬，且導電率為5,000 S/m以上。板狀基底21如包含聚對苯二甲酸乙二醇酯，蒸鍍前述金屬而形成導電性圖案22。在此等導電性圖案22之近旁設置貯藏體層14, 13。

各導電性圖案22之尺寸依對象之電磁波頻率予以最佳

化，而決定為前述之尺寸。因此，前述尺寸係一種範例，且係依據對象之電磁波頻率而適切決定。此外，各導電性圖案22之間隔亦是依據對象之電磁波頻率，以接收效率提高之方式決定。此外，貯藏體層之特性，具體而言，為依據材質等之複數相對介電常數或複數相對磁導率及厚度等，依據對象之電磁波頻率，以接收效率提高之方式而決定。如此，決定導電性圖案22之尺寸及間隔尺寸，並構成貯藏體層，而可有效接收電磁波。

此外，本發明另外實施形態之片體10，如將難燃劑或難燃輔助劑添加於圖案層15、貯藏體層之至少任何一個，而賦予難燃性、準不燃性或不燃性。在圖案層15及貯藏體層中如添加有難燃劑或難燃輔助劑。藉此，在片體10中賦予難燃性。此外，亦可在片體10之至少外周之一部分，以具有難燃性或不燃性之材料覆蓋。如行動電話等之電子機器，其內裝之聚合物材料亦要求難燃性。

此種獲得難燃性用之難燃劑並無特別限定，如可適切使用磷化合物、硼化合物、溴系難燃劑、鋅系難燃劑、氮系難燃劑、氫氧化物系難燃劑及金屬化合物系難燃劑等。磷化合物如為磷酸酯、磷酸鈦等。硼化合物如為硼酸鋅等。溴系難燃劑如為：六溴苯、六溴環十二烷、十溴苄基苯基醚、十溴苄基苯基氧化物、四溴雙酚、溴化鉍等。鋅系難燃劑如為碳酸鋅、氧化鋅或硼酸鋅等。氮系難燃劑如為三氮雜苯化合物、受阻胺化合物或三聚氰胺三聚氰酸脂、三聚氰胺胍化合物之三聚氰胺系化合物等。氫氧化物系難燃

劑如為氫氧化鎂、氫氧化鋁等。金屬化合物系難燃劑如為三氧化銻、氧化鉬、氧化錳、氧化鉻、氧化鐵等。

本實施形態於重量比中，藉由以結合材為100，溴系難燃劑為20，三氧化銻為10，磷酸酯為14之比分別添加，於UL94難燃試驗中可獲得相當於V0之難燃性。片體10可適合作為構成此種物品之素材，或是安裝於物品。如可適合安裝於飛機、船舶及車輛內之裝置等，而在希望防止燃燒及其產生之氣體的空間等中使用之物品。

此外，片體10具有電絕緣性。具體而言，藉由各層14、13由前述之材料構成，片體10之表面電阻率(JIS K6911)為 $10^2 \Omega/\square$ 以上。貯藏體層之表面電阻率宜較大。因此，可實現之最大值成為表面電阻率之上限值。如此具有高表面電阻率及電絕緣性。

此外，片體10具有耐熱性。具體而言，在橡膠或樹脂材料中添加交聯劑時之片體10之耐熱溫度為 150°C ，片體10至少達到超過 150°C 之溫度，其特性不產生變化。關於耐熱性，藉由以陶瓷或耐熱性樹脂(如在聚苯硫化物樹脂中添加 SiO_2 填料者)覆蓋標籤54、片體10、天線元件及IC晶片之至少一部分，即使在 150°C 以上，仍可保持耐熱性。以陶瓷覆蓋時，可為完全燒結，亦可為部分燒結或未燒結。

此外，本發明之其他實施形態，亦可形成不在圖1所示之實施形態之片體10中設置反射區域形成層12之構造。即使是不設置反射區域形成層12之構造，藉由設置於具有由

導電性材料構成部分之物體之面上而構成，仍可獲得相同之效果。此外，使用反射區域形成層12之構造，而防止受到各片體10之設置位置之影響，亦即，依構成妨礙通信構件之材料等，導致導電性圖案22之共振頻率變化，及片體10之接收特性變化。藉此，可防止天線元件51之通信條件變化，而可使天線元件51之通信條件穩定化。如即使將片體10設於建築物內裝材中，仍可防止受到其內裝材之複數相對介電常數等之影響，而導致可接收之頻率變化。

本發明使用之導電性圖案包含：以不連續之形態排列具有導電性之圖案之情況；及自具有導電性之層挖空成孔隙(空孔)狀之形態而形成之情況。而圖案之形狀中並無限制。可採用單一或數種使用，或組合使用圓形、方形、線狀、多角形、帶狀、不定形狀等可發揮天線功能之全部形狀。

圖3係顯示構成本發明一種實施形態之片體10之圖案層15之前視圖。圖4及圖5係圖3所示之實施形態中之圖案層15之一部分放大之前視圖。圖案層15在板狀基底21之電磁波入射側表面上形成導電性圖案22。板狀基底21如由合成樹脂之電介質而構成，該板狀基底21亦是介電材。導電性圖案22包含：放射形圖案30與矩形圖案31。板狀基底21與各導電性圖案22電性絕緣。圖3、圖4及圖5中，為了容易瞭解，而在導電性圖案22中附加斜線之陰影線來顯示。

放射形圖案30形成放射形狀，複數放射形圖案形狀30a相互隔以間隔(以下稱「放射形圖案間隔」)c2x, c2y而設

置。進一步具體說明，如本實施形態之放射形圖案形狀30a係形成沿著相互垂直之x方向及y方向之放射狀之十字狀，並在x方向隔以放射形圖案間隔 $c2x$ ，在y方向上隔以放射形圖案間隔 $c2y$ ，而規矩地配置成行列狀。

放射形圖案形狀30a係將圖5中以虛擬線表示之十字形40為基礎，而將交叉部分36之4個角部41形成曲線狀，具體而言係形成圓弧狀之形狀。成為基礎之十字形(以下稱為基礎十字形)40，係細長延伸於x方向之長方形之形狀部分34與細長延伸於y方向之長方形之形狀部分35，重疊此等各形狀部分34, 35之圖心，而在交叉部分36直角地交叉之形狀。各形狀部分34, 35在交叉部分36，於垂直之軸線周圍偏差90度，而具有相同形狀。其係將直角等腰三角形，且與直角之角部相對之斜邊朝向直角之角部而凹下之圓弧狀之4個大致三角形42，以直角之角部收納於基礎十字形40之各交叉部分36之角部41之方式而設置於該基礎十字形40中之形狀。

對象之電磁波頻率為2.4 GHz頻帶時，列舉放射形圖案形狀30a之一種尺寸，各形狀部分34, 35之寬度 $a1x$, $a1y$ 相等，如為1.0 mm，各形狀部分34, 35之長度 $a2x$, $a2y$ 相等，如為25.0 mm。形成弧狀之角部之圓弧狀之尺寸，亦即除去大致三角形42斜邊之邊長，具體而言係x方向之邊長 $a3x$ 及y方向之邊長 $a3y$ 相等，如為11.5 mm，斜邊之曲率半徑 $R1$ 為11.5 mm。放射形圖案間隔之x方向間隔 $c2x$ 與y方向之間隔 $c2y$ 相等，如為4.0 mm。

矩形圖案形狀 31a 係在被放射形圖案形狀 30a 包圍之區域，自放射形圖案形狀 30a 隔以間隔(以下稱為「放射-方形間隔」) c1 而配置，並以全面佔滿被放射形圖案形狀 30a 包圍之區域之方式設置。進一步詳細而言，係形成對應於被放射形圖案部包圍之區域之形狀。進一步具體說明，如本實施形態之放射形圖案部 30 係前述之十字形，被放射形圖案形狀 30a 包圍之區域係以長方形為基礎之大致長方形，而形成對應於其之形狀，亦即係形成放射-方形間隔 c1 在全周相同之形狀。各形狀部分 34, 35 如前述為相同形狀時，被放射形圖案形狀 30a 包圍之區域成為以正方形為基礎之大致正方形，矩形圖案形狀 31a 成為以正方形 25 為基礎之大致正方形。矩形圖案形狀 31a 係以成為基礎之正方形(以下稱為基礎正方形) 25 之邊部延伸於 x 方向及 y 方向之任何一方之方式配置。

矩形圖案形狀 31a 係大致矩形狀，且係以基礎正方形 25 為基礎，將 4 個角部 26 形成曲線狀，具體而言係形成圓弧狀之形狀。具體而言，係自基礎正方形 25，以直角之角部收納於正方形之各角部 26 之方式的位置關係而除去直角等腰三角形，且與直角角部相對之斜邊朝向直角之角部而凹下之圓弧狀之 4 個大致三角形 27 之形狀。

對象之電磁波頻率為 2.4 GHz 頻帶時，列舉矩形圖案形狀 31a 之一種尺寸，基礎正方形 25 之 x 方向之尺寸 b1x 與 y 方向之尺寸 b1y 相等，如為 25.0 mm。形成弧狀之角部之圓弧狀之尺寸，亦即除去大致三角形 27 斜邊之邊長，具體而言

係z方向之邊長 b_{2x} 及y方向之邊長 b_{2y} 相等，如為10.0 mm，角部之曲率半徑 R_2 為10.0 mm。放射-方形間隔之x方向之間隔 c_{1x} 與y方向之間隔 c_{1y} 相等，如為4.0 mm。

如此，放射形圖案形狀30a及矩形圖案形狀31a係將大致多角形為基礎，具有至少1個角部係曲線狀之大致多角形之外輪廓形狀之導電性圖案。該圖案於接收電磁波時之共振電流，在形成曲線狀之角部順利地流動。

此外，放射形圖案形狀30a及矩形圖案形狀31a並非沿著前述形狀之外周緣而延伸之封閉迴路的線狀(帶狀)，而係內周部亦全面佔滿之面狀的圖案。因此可在與反射區域形成層12之間形成電容器。

此種片體10可藉由圖案層15而有效接收導電性圖案22之共振頻率之電磁波。片體10之共振頻率首先由導電性圖案22之長度及周圍長來律定。此因係以與特定頻率之電磁波共振之形式接收電磁波，因此依據其特定頻率之電磁波之波長的 $1/2$ 或 $1/4$ 之長度等，來決定共振長度。不過，最後之共振頻率，除了圖案尺寸之外，再加上各導電性圖案22之結合特性及第一及第二貯藏體層14, 13之複數相對介電常數之實數部 ϵ' 或複數相對磁導率之實數部 μ' 之波長縮短效應，來設置表面層16時，係受到其表面層16之複數相對介電常數之實數部 ϵ' 之波長縮短效應，及自第一及第二貯藏體層14, 13決定之輸入阻抗之影響而決定。該共振頻率與用於後述之天線元件51之無線通信時之頻率大致相等。

再者，以配合後述之標籤本體54之大小來使用片體10

時，放射形圖案形狀30a及矩形圖案形狀31a之至少任何一方，可能僅其一部分包含於導電性圖案22。此時，共振頻率係因應圖案形狀之縮短，亦即係因應包含於導電性圖案22之放射形圖案形狀30a之一部分形狀及大致矩形圖案形狀31a之一部分形狀，而向高頻側偏移。

圖6係顯示以模擬計算藉由導電性圖案22切斷之影響而變化之共振頻率之結果圖。圖7係顯示用於模擬之片體10之導電性圖案22之圖案形狀之前視圖。圖7中，橫軸表示頻率，縱軸表示反射損失。反射損失係從入射於片體10之電磁波被片體10反射之觀點而觀察時之損失，且係對應於片體10中電磁波接收量之值。反射損失以負值表示，反射損失之絕對值成為電磁波之接收量。亦即，成為作為天線之特性評估的指標。反射損失之值愈小，表示片體10接收電磁波之效率愈高。本發明之反射損失量之計算，係以電腦模擬來進行。模擬時使用TLM法，並使用Flomerics社製「Micro-Stripes」。進行其計算時，第一貯藏體層14之如2.4 GHz頻帶之材料常數分別為：複數相對介電常數之實部 ϵ' =12.3，複數相對介電常數之虛部 ϵ'' =1.3，複數相對磁導率之實部 μ' =1.3，複數相對磁導率之虛部 μ'' =0.5，厚度為0.5 mm。第二貯藏體層13之如2.4 GHz頻帶之材料常數為： ϵ' =4.6， ϵ'' =0.1，厚度為2.0 mm。模擬時係計算在金屬板上堆疊片體10狀態下之頻率及反射損失之關係。

成為用於模擬之圖案層15之基本之導電性圖案22係 $a1x=a1y=1.0$ mm， $a2x=a2y=17.5$ mm， $a3x=a3y=7.5$ mm，

$c1x=c1y=1.5$ mm, $c2x=c2y=7.0$ mm, $b1x=b1y=20.5$ mm, $c1x=c1y=1.5$ mm, $R1=7.5$, $R2=7.0$ mm。此外, 垂直於片體 10 之疊層方向之長度方向(x方向)之尺寸 1 及寬度方向(y方向)之尺寸 L2 分別為 $L1=80$ mm, $L2=20$ mm。

將藉由切割用於模擬之片體 10 之導電性圖案 22 之一部分而形成之兩種圖案形狀, 分別設為第一圖案形狀 22A 及第二圖案形狀 22B, 並將形成有第一圖案形狀 22A 之片體 10 設為第一片體 10A, 將形成有第二圖案形狀 22B 之片體 10 設為第二片體 10B。

圖 7 係第一片體 10A 之前視圖。第一圖案形狀 22A 包含導電性圖案 22 中, 被通過放射形圖案形狀 30a 之圖心而平行於 x 方向之 2 個邊, 與通過放射形圖案形狀 30a 之圖心而平行於 y 方向之 2 個邊所形成之長方形包圍之部分之大致矩形圖案形狀 31a 與放射形圖案形狀 30a 之一部分。第一圖案形狀 22A 包含沿著 x 方向排列成 1 行, 各個圖心設於 y 方向中央之 4 個大致矩形圖案形狀 31a, 與排列於大致矩形圖案形狀 31a 周圍之放射形圖案形狀 30a 之一部分。

圖 6 中之實線 38 表示第一片體 10A 之頻率 - 反射損失特性。片體 10 之導電性圖案 22 係配合 2.4 GHz 頻帶而設計成為反射損失之峰值之頻率(共振頻率)者, 抽樣切割後之第一片體 10A, 其共振頻率比 2.4 GHz 頻帶, 向高頻側偏移。此時之共振頻率係在安裝天線元件 51 之前階段之片體 10 單體時者。

圖 6 中, 第一片體 10A 之共振頻率與 2.4 GHz 頻帶不一

致，但是反射損失變大之共振峰值38A之前襟部分有2.4 GHz頻帶，亦即，由於2.4 GHz頻帶中之反射損失大，因此判明有收集2.4 GHz頻帶之頻率之電磁波的能力(收集而供給之能力)。這表示片體10在對象之2.4 GHz頻帶中，雖共振頻率並未完全地符合，但是藉由電抗匹配等來調整共振頻率時，可將片體10作為抑制金屬面等之影響之收發天線，而發揮將電磁波供給至天線元件51之作用上之增強天線之功能。

藉由在片體10上設置天線元件51，雖然共振頻率有可能進一步偏移，但是，藉由天線元件51與片體10間之距離調整、介電常數或磁導率調整、及調整導電性圖案22之切斷方法及天線元件51之尺寸，仍可對應。在天線元件51與片體10之間，可使用接合材或黏合材而介有如適當厚度之發泡體、樹脂、紙等。

片體10藉由形成前述之疊層構造，可提高電磁波之接收效率，因此作為天線功能可獲得大的增益，並可謀求薄型化及輕量化。

此外，導電性圖案22中，放射形圖案形狀30a如前述係以使延伸成放射狀之部分相互對接之方式配置，矩形圖案形狀31a形成對應於被放射形圖案形狀30a包圍之區域之形狀。該配置之接收原理不同(放射形圖案成為雙極天線，矩形圖案成為修補(patch)天線)，藉由組合放射形圖案30與矩形圖案31接收效率最佳(提高)。因此，可實現接收效率高之片體10。此外，放射形圖案形狀30a係沿著x方向及

y方向而放射之配置，並且係以成為矩形圖案形狀31a之基礎之正方形之邊部延伸於x方向及y方向之方式配置，可提高在x方向及y方向存在電場方向而偏振之電磁波之接收效率。

片體10上，接收電磁波之導電性圖案22具有基本上為多角形之大致多角形之外輪廓性狀，可比導電性圖案22之外輪廓形狀為圓形時，提高增益之峰值。因而，基本上為多角形，而至少1個角部形成曲線狀。藉此，可抑制並減少藉由電磁波之偏振方向，增益達到峰值之頻率之偏差。因此，可獲得增益之峰值高，且藉由電磁波之偏振方向而增益達到峰值之頻率偏差小之優異之接收特性。

片體10藉由圖案層15之導電性圖案22，按照天線之共振原理而接收特定頻率之電磁波。換言之，本發明之片體10即使導電性圖案22作為接收天線，仍具有有效地動作之功能。此時，特定頻率係依導電性圖案22之形狀及尺寸等諸元而決定之頻率。以導電性圖案22接收電磁波時，共振電流流入導電性圖案22之端部，而在導電性圖案22之周緣部周圍產生電磁場。片體10藉由共振而使特定頻率之電磁波集中於片體內部。

再者，藉由在圖案層15與導電性層之間介有貯藏體層之疊層狀態下使用片體10，可在圖案層15之導電性圖案22與導電性層之間構成電容器或電感器。導電性層於本實施形態係反射區域形成層12，在不設置反射區域形成層12之其他形態中，則是由導電性材料構成之物體的表面層。縮短

導電性圖案 22 與導電性層之距離時，可增大電容器之電容。此外，導電性圖案 22 相互間亦可形成電容器。電容器可儲存特定頻率之電磁能。此外，藉由利用電容器等，可藉由賦予電抗調整功能而達成薄型化。藉此，可在片體 10 中儲存對應於特定頻率之電磁能。在外觀上是儲存電磁能，不過，片體 10 實際上係使捕捉之電磁能不斷地通過。片體 10 以作為高性能之小型天線功能之導電性圖案 22 高效率地再放射特定頻率之電磁波，與入射波干擾，而形成電場強度強之區域，使後述之天線元件 51 發揮藉由電磁結合而傳送此等能量之角色。

圖 8 係分解包含片體 10 之標籤 50 而顯示之立體圖。標籤 50 係藉由無線通信而傳達資訊之一種電子資訊傳達裝置，如用作利用於固體自動識別之 RFID(無線頻率識別)系統之轉發器。標籤 50 包含：天線元件 51，電性連接於天線元件 51，而使用天線元件 51 進行通信之通信機構之積體電路(以下稱「IC」)52 及片體 10。標籤 50 係構成藉由天線元件 51 接收來自讀取器之要求信號時，藉由天線元件 51 傳送表示記憶於 IC52 內之資訊之信號。因此，讀取器可讀取保持於標籤 50 之資訊。標籤 50 如貼合於商品而設置，用於商品管理，而防止商品遭竊及掌握庫存狀況等。包含天線元件 51 與片體 10 而構成天線裝置。標籤 50 係藉由天線元件 51 收發電磁波信號之電子資訊傳達裝置，且係利用接收之電磁波信號之能量回覆電磁波信號之無電池標籤。標籤 50 亦可為無電池標籤，亦可為內藏電池之電池標籤。

天線機構之天線元件51至少係電場型之天線元件，且係雙極天線或迴路天線或是單極天線，本實施形態係藉由雙極天線來實現。本發明之其他實施形態中，天線元件51亦可藉由其他天線而實現。藉由組合雙極天線與片體10，可實現天線元件51之小型化。藉由片體10之複數相對磁導率之實數部 μ' 及複數相對介電常數之實數部 ϵ' 之高度互相結合，除波長縮短效應之外，還可達成天線元件51之小型化。雙極天線係線狀，可以有曲線及曲折，全長為 $\lambda/2$ 即可。如950 MHz時約為15.8 cm之長度，其中加上片體10之波長縮短效應，可形成約3~10 cm之線狀元件，即使加上曲折，其尺寸仍可保持在2~3 cm之程度。再者，亦可予以小型化，而使貼合對象之範圍廣。單極天線係在雙極天線之一側的元件與接地板之間供電，因此，可使元件全長進一步小型化成 $\lambda/4$ 。形成迴路天線時，於全周接近1個波長時，可近似於將2個半波長雙極天線並列之構造，而可視為電場型之天線元件。為完全磁場型時，若係電場型與磁場型切換者或電場型與磁場型之功能並存者時，亦包含於本發明之天線元件。此外，本發明之天線元件中亦包含安裝電抗構造部者。

天線元件51藉由形成於由聚對苯二甲酸乙二醇酯(PET)構成之基底53之厚度方向一方側之表面部之圖案導體而實現。IC52配置於天線元件51之如中央部，而與天線元件51電性連接。IC52至少包含：記憶部與控制部。記憶部中可記憶資訊，控制部可使記憶部記憶資訊，或是自記憶部讀

取資訊。該IC52回應藉由天線元件51而接收之電磁波信號表示之指令，將資訊記憶於記憶部中，或是讀取記憶於記憶部中之資訊，並將表示該資訊之信號供給至天線元件51。基底53係長方形板狀，天線元件51延伸於長度方向而設於基底53之中央部。天線元件51及IC52之層之厚度尺寸為1 nm以上，500 μm以下，基底53之層之厚度尺寸為0.1 μm以上，2 mm以下。亦可為在片體10上直接印刷、加工天線元件51，而不使用基底之構造。

藉由天線元件51、IC52及基底53而構成標籤本體54。標籤本體54搭載於具有撓曲性之接合膠帶等加以包裝。藉由標籤本體54與片體10而構成標籤50。圖8中分解標籤本體54與片體10來顯示，不過，標籤本體54係使形成天線元件51之表面部，與片體10之一個表面(本實施形態為圖案層15之一個表面)相對而堆疊。天線元件51之表面藉由厚度為25 μm之由聚對苯二甲酸乙二醇酯構成之絕緣膜覆蓋，藉此，天線元件51與導電性圖案22絕緣。亦有在標籤本體54(亦有不合基底53之構造)與片體10之間，使用黏合劑及接合劑貼合，或是標籤本體54或片體10之任何一方或兩者具有黏合性及接合性而貼合之情況，不過圖8並未顯示。片體10形成長方形板狀，與標籤本體54堆疊而構成之標籤50成為長方形板狀。

片體10與標籤本體54之結合構造並無特別限定，亦可使用包含黏合劑及接合劑之結合劑而結合。在形成於片體10表面附近之電場強之區域，片體10與天線元件51在不導通

之狀態下堆疊，亦即，係經由具有電絕緣性之非導通層(亦可為電介質層或磁性體層)而堆疊。該片體10與天線元件51之距離可從天線元件51之通信特性來決定最佳位置。圖8中省略結合片體10與標籤本體54用之構造來顯示。標籤50自厚度方向之一方側向另一方側，依序堆疊有：基底53之層、天線元件51及IC52之層、標籤本體接合層、圖案層15、第一貯藏體層14、第二貯藏體層13、反射區域形成層12及貼合層11。

天線元件51可朝向與天線元件51延伸之方向交叉之方向傳送電磁波信號，並可接收自與天線元件51延伸之方向交叉之方向到來之電磁波信號。本實施形態可將天線元件51為基準，而向與片體10相反側之收發方向A傳送電磁波信號，並接收自收發方向A到來之電磁波信號。

標籤50如自讀寫器之資訊管理裝置，藉由天線元件51而接收表示預定須記憶之資訊(以下稱「主資訊」)，及指示記憶其主資訊之資訊(以下稱「指示記憶資訊」)之電磁波信號時，係自天線元件51對IC52供給表示主資訊及指示記憶資訊之電信號。IC52之控制部依據指示記憶資訊，而將主資訊記憶於記憶部中。

此外，藉由天線元件51接收表示指示自資訊管理裝置傳送記憶於記憶部之資訊(以下稱「記憶資訊」)之資訊(以下稱「指示傳送資訊」)之電磁波信號時，係自天線元件51供給表示指示傳送資訊之電信號至IC52。IC52之控制部依據指示傳送資訊，而讀取記憶於記憶部中之資訊(記憶資

訊)，並將表示其記憶資訊之電信號供給至天線元件51。藉此，自天線元件51傳送表示記憶資訊之電磁波信號。

圖9係顯示將標籤50貼合於妨礙通信構件57之狀態圖。標籤50為了可在妨礙通信構件之妨礙通信構件57近旁使用，而包含片體10。本發明中所謂一個妨礙通信材料之導電性材料，如係指包含：金屬、矽系材料、黑鉛片等之碳系材料、ITO及ZnO等氧化物及水等之液體，而在與天線元件之間具有可高頻地引起短路之程度的導電率之材料。導電性材料係具有導電性之材料，並包含：金屬等電阻率為 10^{-6} Ωcm以上，而未達 10^{-1} Ωcm之電阻率較低之材料；及水及海水等液體與半導體等電阻率為 10^{-1} Ωcm以上， 10^6 Ωcm以下之電阻率較高之材料。

片體10對天線元件51設於與收發方向A相反側。片體10藉由貼合層11貼合於妨礙通信構件57來使用。該標籤50係以比天線元件51將片體10配置於妨礙通信構件57側，並在天線元件51與妨礙通信構件57之間介有片體10之方式而設置。

圖10係顯示天線元件51與圖案層15之電磁耦合及圖案層15與電波反射層12之電磁耦合之剖面圖。另外，圖10中為了容易瞭解，於標籤50之構造中省略天線元件51、IC52及片體10以外之構造而顯示。在天線元件51之近旁不存在妨礙通信構件57之自由空間，藉由天線元件51兩端部51a, 51b之電位差而產生之電場，直接在空間中擴大，藉由電場之強度變化而形成磁場，再者，藉由其磁場強度之變化

而形成電場。天線元件51利用此種電場及磁場之形成現象依序連續地反覆之原理，可傳送電磁波。此外，天線元件51可藉由與傳送原理相反之原理，而接收共振頻率之電磁波。

圖13係電磁波入射於標籤50時，圖案層15之導電性圖案22作為天線，藉由片體10之各層12~15而決定之共振頻率之特定頻率之電磁波入射時，發現共振現象，其頻率之電磁波集中於片體10內。在圖案層15與反射區域形成層12之間介有具有介電性及磁性之第一貯藏體層14，藉由如前述地選擇該第一貯藏體層14之磁導率之實數部(μ')，而使進入片體10之電磁波沿著第一貯藏體層14傳播，可將天線元件51之通信妨礙程度抑制在最小限度。圖13中，行波進入片體10後，雖僅通過第一貯藏體層14，不過這是一例，因片體10內全層之作用，而產生通信改善效果。

在導電性圖案22之周邊部分發生電磁場時，電磁場亦發生於夾著圖案層15而與第一貯藏體層14之相反側。在圖案層15之近旁設置有天線元件51，在導電性圖案22之周圍發生電磁場時，導電性圖案22與天線元件51引起電磁耦合，電磁能自導電性圖案22轉移至天線元件51。自導電性圖案22供給共振頻率之電磁能至天線元件51之結果，與不設置圖案層15時比較，可使天線元件51之接收電力增加。標籤50利用接收之電磁波信號之能量而回覆電磁波信號，因此，可藉由接收電力增加而延長通信距離。該電磁波之增強效果亦可從導電性圖案22與反射區域形成層12間之距離

效果作說明。導電性圖案22與反射區域形成層12之間隔之 $((2n-1)/4)\lambda$ (n 為正整數)雖理想，但是藉由貯藏體層之磁導率及介電常數，而縮短獲得與空氣中之 $((2n-1)/4)\lambda$ 之干擾相當之效果的距離。 n 宜為0。

再者，片體10係設計成藉由將取得之電磁波在片體內部調整相位，於電磁波之波長設為 λ 時，使自反射區域形成層離開電性長度為 $((2n-1)/4)\lambda$ 之電場強度增強之區域產生於圖案層15之位置。本發明藉由產生虛擬連結導電性圖案22之中央附近與反射區域形成層之合成電場為0(零)之位置(後述之圖11及圖13中以虛擬線表示之虛擬之電磁波反射面201)，以形成反射區域之虛擬電磁波反射面201反射電磁波，比直線之 $((2n-1)/4)\lambda$ 之距離，利用繞進導電性圖案22，藉由爭取自圖案層15至反射區域之電性長度，而將片體10之厚度比 $\lambda/4$ 更大程度地薄型化。圖13中以箭頭符號202表示自本發明之圖案層15至反射區域之電性長度為 $((2n-1)/4)\lambda$ 之部分。如上述，在導電性圖案之位置，電場強度亦干擾而增加。藉由此等增強效果，片體10亦可說是作為增強天線之功能。因此，即使在妨礙通信構件57之近旁，仍可正常進行無線通信，並可確保充分之通信距離。如此，藉由包含導電性圖案22，使片體10獨自具備天線功能，可獲得天線元件51之通信改善效果。

在天線元件51之兩端部51a, 51b產生電位差之狀態下，天線元件51之兩端部51a, 51b成為正或負地分別帶電之狀態，藉此，於天線元件51之兩端部51a, 51b與反射區域形

成層 12 中分別與天線元件 51 之兩端部 51a, 51b 相對之部分 12a, 12b 之間形成電場，而成為與天線元件 51 之兩端部 51a, 51b 正負相反地帶電之狀態。天線元件 51 中藉由 IC52 施加交變電壓，兩端部 51a, 51b 以正或負交替之方式帶電。片體 10 設於電場型之天線元件 51 與妨礙通信構件 57 之間時，可使天線元件 51 與妨礙通信構件 57 之距離背離，因此，藉由天線元件 51 之兩端部 51a, 51b 帶電而產生，形成於與妨礙通信構件 57 之間之電場強度變小。本實施形態藉由在片體 10 上形成有反射區域形成層 12，在天線元件 51 與反射區域形成層 12 之間形成貯藏體層，可使天線元件 51 與反射區域形成層 12 之電性長度背離，因此，藉由天線元件 51 之兩端部 51a, 51b 帶電而產生，形成於與反射區域形成層 12 之間之電性短路程度變小。

以上現象亦應在天線元件 51 與導電性圖案 22 之間發生。但是，由於導電性圖案 22 比對應之天線元件 51 小且不連續，因此不足以影響天線元件之阻抗降低。

因此，在天線元件 51 與妨礙通信構件 57 或反射區域形成層 12 之間之高頻之短路電路之形成減弱。亦即，在電容器中施加高頻電壓時，與形成與通電者相同狀態同樣地，藉由高頻地短路之現象，可抑制流入天線元件 51 與妨礙通信構件 57 或反射區域形成層 12 之間之高頻電流，而抑制天線元件 51 之輸入阻抗之降低。抑制輸入阻抗之降低，則可從產生於天線元件 51 之電流之電流值，成為接近妨礙通信構件 57 不存在時之較小值而確認。如此，可藉由使用片體 10

來抑制輸入阻抗之降低。輸入阻抗變小時，與使用天線元件51而通信之通信機構(IC52)之阻抗背離，在天線元件51與通信機構之間，無法收發信號，不過，由於可藉由片體10抑制天線元件51之輸入阻抗降低，因此，即使在妨礙通信構件57之近旁，仍可正常進行無線通信。由於抑制該輸入阻抗之降低，亦可對導電性圖案22施加細縫、凹凸、傾斜、濃淡等，作為導通之電阻。

圖11係模式顯示入射於片體10之電磁波(稱為行波)及藉由片體10而反射之電磁波(稱為反射波)之圖，圖12係電磁波反射之說明圖，圖13係放大圖11所示片體10之一部分而模式顯示之圖。圖11及圖13中，為了容易瞭解，從標籤50之構造中，省略天線元件51、IC52及片體10以外之構造來顯示。行波入射於圖案層15時，該行波被導電性圖案22接收，並藉由貯藏體層在外觀上收集行波之能量。此外，圖13中，以虛線顯示在片體10內部藉由電磁波而產生之電場的方向。

片體10藉由最佳地設計前述之圖案層15，可使貯藏體層薄型化，並可有效接收電磁波。再者，藉由使用形成數種導電性圖案之圖案層15，可產生導電性圖案22中之接收動作特性，而有效接收，並且可藉由此等相互電性絕緣而謀求頻率帶域之廣域化，而可有效接收廣帶域之電磁波。

如此，由於可提高對寬廣頻率帶域之電磁波之接收效率，因此，可獲得寬且高之電磁波接收性能，可謀求薄型化及輕量化，進一步可提高貯藏體層材質之選擇自由度，

而保持彈性，可獲得製造性優異之片體10。

電磁波之行波與反射波干擾而產生駐波，並藉由反射區域形成層12而形成，藉由自電磁波反射之反射面(反射區域)之距離，而如圖12所示，電場及磁場互相增強或互相減弱。此時反射波(電場)之相位與行波之相位偏差 180° 。圖12及圖13中顯示駐波。圖12中以實線表示電場之駐波，以虛線表示磁場之駐波。此外，圖13中以虛線表示電場之駐波。省略形成駐波之機制，而圖12及圖13僅顯示強度(即使僅表示振幅，亦為相同之圖)。在自反射面離開 $((2n-1)/4)\lambda$ (n 為正整數)之位置，電場強度最高，同時磁場強度為0(零)。圖12所示之反射面與合成電場為0(零)之面等價，且與金屬面等價。

在與圖案層15之間夾著貯藏體層，對圖案層15及第一及第二貯藏體層14, 13，在與天線元件51相反側，以天線元件51及圖案層15中，與導電性圖案22間之部分之至少任何一方之電性長度成為 $((2n-1)/4)\lambda$ (n 為正整數)之方式隔以間隔，前述虛擬之電磁波反射面201，以結合導電性圖案22與反射區域形成層12之方式而形成。虛擬之電磁波反射面201係在導電性圖案22之中央部份與反射區域形成層12之間產生之電場強度為0(零)之區域。由於電場強度為0(零)，因此，如同作為電磁波之反射板之功能，自導電性圖案22進入片體10之電磁波被該虛擬之電磁波反射面201反射而返回。亦即，天線元件51及圖案層15中，與導電性圖案22間之部分之至少任何一方與虛擬之電磁波反射面

201，僅離開在圖案層15及貯藏體層中進行之電磁波之波長的 $((2n-1)/4)$ 倍之距離而設置。電磁波之波長藉由圖案層15及貯藏體層之各效果，比在空氣中之波長短，因此，在薄型片中實現自圖案層15之入射部至虛擬之電磁波反射面201相當於電磁波之波長之 $((2n-1)/4)$ 倍($n=0$ 時，實質為 $\lambda/4$)。此外，天線元件51及圖案層15中，藉由將自與導電性圖案22間之部分至少任何一方至虛擬之電磁波反射面201電性地作為 $((2n-1)/4)\lambda$ (n 為正整數)之距離，可利用片體10內之複數相對介電常數之實數部 ϵ' 及/或複數相對磁導率之實數部 μ' 之電磁波傳播路徑之彎曲爭取距離， $n=0$ 時，可使自圖案層15至反射區域形成層12之距離(片體10之厚度)比 $\lambda/4$ 大幅薄型化。此種薄型化技術迄今尚未曾提出。

就電場而言，電磁波之波長為 λ 時，自反射區域形成層12之反射面背離 $n \times (\lambda/2)$ (n 為正整數)之位置，行波藉由反射波而抵銷，但是自反射區域(虛擬之電磁波反射面201)之電性長度隔以波長之 $((2n-1)/4)$ 倍間隔之位置，行波與反射波干擾而互相增強。藉由在反射之電磁波與到來之電磁波互相增強而干擾之位置設置天線元件51，即使在妨礙通信構件57之近旁，仍可正常地進行無線通信。

圖14係放大標籤50之一部分而顯示之立體圖，且欠缺堆疊於片體10之標籤本體54之一部分來顯示。圖15係就圖14所示之以虛擬線48表示之區域，顯示模擬之電場強度圖。圖15中，電場之強度以灰色標度表示，並以白色之部分中

電場強，隨著自白色接近黑色，電場減弱之方式來表示。從模擬之結果，在矩形圖案形狀31a部分看出電場強之區域。用於計算之電場向量在圖15中係橫向，磁場向量係縱向，在圖15之矩形圖案形狀31a右側部分，亦形成黑之電場為0(零)之區域。該區域係前述之虛擬之電磁波反射面201。

此外，接收電磁波之導電性圖案22具有基本上為多角形之大致多角形之外輪廓形狀，與導電性圖案22之外輪廓形狀為圓形時比較，可提高增益之峰值。

此因，為多角形圖案時，Q值比圓形圖案高。首先說明Q值，共振之Q值可以帶域寬來表示。兩者之關係成為 $Q = \text{共振頻率} / \text{帶域寬}$ 。因此，Q值高者，帶域寬度窄。

該關係應用於使用圖案之增益之峰值來表現。亦即，所謂多角形圖案之Q值高，係窄之接收帶域並具有高之增益，所謂Q值低，顯示寬之接收帶域，但是表示增益低。

多角形圖案之Q值高，反而接收帶域窄，因偏振之影響，而發生共振頻率偏移。這可藉由在方形(四方形)圖案施加 0° 之電場(無偏振之狀態)時，強電流沿著矩形圖案之邊流動，而在該部分引起共振，反之，以矩形圖案將電場傾斜 45° 時，或是圓形圖案時，產生強電流流動之路徑，並非如矩形圖案於 0° 時變細而集中於邊緣之現象來說明。換言之，可以說藉由電流路徑擴大，關於共振之半波長之波分布的區域擴大，共振之條件增加，因而爭取帶域寬。如為矩形圖案之情況，接收電磁波(TE波)時，係與邊平行

且筆直地形成電場，但是使方形旋轉 45° 時，接收電磁波(TE波)時之圖案內的電場係圓弧狀產生，因此明顯地分布不同。亦即方形(多角形)圖案係共振集中而產生，因而接收提高，但是有容易發現偏振依存性之缺點。

為了改善該缺點，圖案形狀基本上是多角形，不過至少1個角部須形成曲線狀。此時在角部賦予R，亦即形成曲面狀之效果，係共振電流在角部不滯留而容易流動，且共振之區域擴大，結果之Q值雖然降低若干，但是藉由顯示廣帶域性能，而改善偏振特性。藉此，可藉由電磁波之偏振方向抑制且減少增益達到峰值之頻率偏移。因此可實現增益之峰值高，且藉由電磁波之偏振方向，增益達到峰值之頻率偏移小(偏振損失小)之優異接收特性的片體。

導電性圖案22基本上為多角形，且藉由至少將一部分角部形成曲線狀，可實現增益之峰值高，且藉由電磁波之偏振方向而增益達到峰值之頻率偏移小之優異接收特性的片體。

圖16係將構成圖1所示之實施形態中之片體10之其他實施形態之圖案層15之一部分予以放大顯示之立體圖。此時之導電性圖案22包含：兩種幾何學形狀之放射形圖案30及矩形圖案31。圖16中，為了容易瞭解，而將導電性圖案22附加斜線陰影線來顯示。

放射形圖案形狀30a將圖16中以虛擬線表示之基礎十字形40作為基礎，將交叉部分36之4個角部41及除去該角部41之其餘角部58形成曲線狀，具體而言係形成圓弧狀之形

狀。角部58形成向外方凸出之圓弧狀。

放射形圖案形狀30a之一種尺寸如為：各形狀部分34, 35之寬度 a_{1x} , a_{1y} 相等，如為1.0 mm，各形狀部分34, 35之長度 a_{2x} , a_{2y} 相等，如為17.5 mm。形成弧狀之角部成為圓弧狀之尺寸，亦即除去大致三角形42斜邊之邊長，具體而言係x方向之邊長 a_{3x} 及y方向之邊長 a_{3y} 相等，如為7.5 mm，斜邊之曲率半徑R1為7.5 mm。此外，角部58之外周邊之曲率半徑R3，為7.0 mm。放射形圖案間隔中，x方向之間隔 c_{2x} 與y方向之間隔 c_{2y} 相等，如為7.0 mm。此外，矩形圖案形狀31a之x方向之尺寸 b_{1x} 與y方向之尺寸 b_{1y} 相等，如為20.5 mm。放射形圖案形狀30a與矩形圖案形狀31a之放射-方形間隔中，x方向之間隔 c_{1x} 與y方向之間隔 c_{1y} 相等，如為1.5 mm。即使如此構成，仍可達到相同之效果。

圖17係將構成圖1所示之實施形態中之片體10之其他實施形態之圖案層15之一部分予以放大顯示之立體圖。此時之導電性圖案22包含：放射形圖案30及矩形圖案31。圖17中，為了容易瞭解，而將導電性圖案22附加斜線陰影線來顯示。

放射形圖案形狀30a將圖17中以虛擬線表示之基礎十字形40作為基礎，將交叉部分36之4個角部41及除去該角部41之其餘角部58形成曲線狀，具體而言係形成圓弧狀之形狀。角部58形成向外方凸出之圓弧狀。

放射形圖案形狀30a之一種尺寸如為：各形狀部分34, 35之寬度 a_{1x} , a_{1y} 相等，如為2 mm，各形狀部分34, 35之長

度 a_{2x} , a_{2y} 相等, 如為 10 mm。形成弧狀之角部成為圓弧狀之尺寸, 亦即除去大致三角形 42 斜邊之邊長, 具體而言係 x 方向之邊長 a_{3x} 及 y 方向之邊長 a_{3y} 相等, 如為 3 mm, 斜邊之曲率半徑 R_1 為 0.5 mm。此外, 角部 58 之外周邊之曲率半徑 R_3 , 為 0.5 mm。放射形圖案間隔中, x 方向之間隔 c_{2x} 與 y 方向之間隔 c_{2y} 相等, 如為 2 mm。此外, 矩形圖案形狀 31a 之 x 方向之尺寸 b_{1x} 與 y 方向之尺寸 b_{1y} 相等, 如為 6 mm。放射形圖案形狀 30a 與矩形圖案形狀 31a 之放射-方形間隔中, x 方向之間隔 c_{1x} 與 y 方向之間隔 c_{1y} 相等, 如為 2 mm。即使如此構成, 仍可達到相同之效果。

圖 18 係將構成圖 1 所示之實施形態中之片體 10 之其他實施形態之圖案層 15 之一部分予以放大顯示之立體圖。此時之導電性圖案 22 包含: 放射形圖案 30 及矩形圖案 31。圖 18 中, 為了容易瞭解, 而將導電性圖案 22 附加斜線陰影線來顯示。本實施形態中之矩形圖案形狀 31a, 係將圖 17 所示之導電性圖案 22 之矩形圖案形狀 31a, 將圖心作為中心, 而各變位 90° 來配置之形狀, 其他與圖 17 所示之導電性圖案 22 相同。即使如此構成, 仍可達到相同之效果。

圖 19 係構成圖 1 所示之實施形態中之片體 10 之其他實施形態之圖案層 15 的前視圖, 圖 20 係將圖 19 之圖案層 15 之一部分放大顯示之立體圖。此時之導電性圖案 22 包含: 角部 41, 58 之外形線形成直角之放射形圖案 30、及角部之外形線形成直角之矩形圖案 31。矩形圖案形狀 31a 係在被放射形圖案形狀 30a 包圍之區域, 自放射形圖案形狀 30a, 在 x

方向及y方向分別隔以放射-方形間隔 c_{1x} , c_{1y} 而配置。圖20中，為了容易瞭解，而將導電性圖案22附加斜線之陰影線來顯示。

放射形圖案形狀30a之一種尺寸如為：各形狀部分34, 35之寬度 a_{1x} , a_{1y} 相等，如為2.5 mm，各形狀部分34, 35之長度 a_{2x} , a_{2y} 相等，如為16.0 mm。放射-方形間隔 c_{1x} , c_{1y} 相等，如為1.0 mm。放射形圖案間隔中，x方向之間隔 c_{2x} 與y方向之間隔 c_{2y} 相等，如為1.0 mm。此外，矩形圖案形狀31a之x方向之尺寸 b_{1x} 與y方向之尺寸 b_{1y} 相等，如為12.5 mm。放射形圖案形狀30a與矩形圖案形狀31a之放射-方形間隔中，x方向之間隔 c_{1x} 與y方向之間隔 c_{1y} 相等，如為1.0 mm。即使如此構成，仍可達到相同之效果。

圖21係構成圖1所示之實施形態中之片體10之其他實施形態之顯示雙峰特性之圖案層15的前視圖。圖22係將圖21所示之實施形態中之圖案層15之一部分放大顯示之立體圖。該圖案層15在板狀基底21之電波入射側的表面上形成導電性圖案22。圖22中，為了容易瞭解，而將導電性圖案22附加斜線之陰影線來顯示。

導電性圖案22，如本實施形態中，單一種類之幾何學形狀之十字形圖案形狀，亦可為自正交座標系統之x方向及y方向，在垂直於圖21之紙面之軸線周圍，變位45度角之正交座標系統之 x_1 方向及 y_1 方向上隔以間隔 c_1 , c_2 ，而行列表地規矩配置之圖案。如此，構成導電性圖案22之圖案形狀61形成x字形。x字形之圖案形狀61，其 x_1 方向上細長延

伸之長方形之形狀部分62，與在y1方向上細長延伸之長方形之形狀部分63，係重疊此等各形狀部分62，63之圖心，而在交叉部分64直角地交叉而形成。各形狀部分62，63在交叉部分64中，於垂直之軸線周圍偏移90度，而具有相同形狀。各形狀部分62，63如亦可為寬度 $a_2=b_1=2.5$ mm，長度 $a_1=b_2=17$ mm，各形狀61之x1方向及y1方向之相互之間隔 $c_1=c_2=1$ mm。此等之圖案形狀61為線狀且具有兩端部之構造，此等之圖案形狀61以彼此不連結之形態排列複數。再者，構成該圖案形狀61之形狀部分62，63係線狀，且具有兩端部之構造，將該形狀部分62，63作為單位，在除去其兩端部之位置，2個以上(本實施形態為2個)單位之形狀部分62，63直角地交叉。即使如此構成，仍可達到相同之效果。顯示雙峰特性者，可提案1個片體10以2個以上之頻率動作之標籤。當然，係在標籤上設置複數天線，無法共用時，亦須設置複數晶片，不過，可提案如藉由以高MHz頻帶與2.4 GHz頻帶之兩頻率進行通信，即使存在妨礙通信構件，仍可改善通信特性之標籤。

圖23係顯示構成圖1所示之實施形態中之片體10之其他實施形態之顯示雙峰特性之圖案層15之前視圖。圖24係圖23所示之實施形態中之圖案層15之一部分放大之立體圖。該圖案層15係在板狀基底21之電波入射側之表面上形成導電性圖案22。圖24中，為了容易瞭解，而將導電性圖案22附加斜線之陰影線來顯示。導電性圖案22，如本實施形態亦可為單一種類之幾何學形狀之方形狀之迴路圖案形狀

(封閉迴路狀)，在正交座標系統之x方向及y方向上隔以間隔 $c5=c6$ ，而行列狀地規矩配置之圖案。此等之圖案形狀以彼此不連結之形態而排列複數。間隔為 $c5=c6=12\text{ mm}$ ，各尺寸如亦可為線寬 $a6=b5=1\text{ mm}$ ，外周部之一邊 $a5=b6=10\text{ mm}$ 。

圖25係顯示構成圖1所示之實施形態中之片體10之其他實施形態之圖案層15之前視圖。圖26係將圖25所示之圖案層15之一部分予以放大顯示之立體圖。圖25及圖26中，為了容易瞭解，而將導電性圖案22附加斜線之陰影線來顯示。此時之導電性圖案22係構成，其單一種類之幾何學形狀之矩形圖案31在x方向及y方向上隔以間隔(以下稱「圖案間隔」) $d1x, d1y$ 而行列狀地規矩配置。圖1所示之圖案層15之導電性圖案22包含：放射形圖案30及矩形圖案31，但是圖25之圖案層15之導電性圖案22僅包含矩形圖案31。

矩形圖案形狀31a係正方形狀，x方向之長度 $b1x$ 與y方向之長度 $b1y$ 相等，如為 21.0 mm ，此外，在x方向及y方向上鄰接之各圖案形狀59之相互間隔之第二圖案間隔中，x方向之間隔 $d1x$ 與y方向之間隔 $d1y$ 相等，如為 1.5 mm 。即使如此構成，仍可達到相同之效果。

圖27係顯示構成圖1所示之實施形態中之片體10之其他實施形態之圖案層15之前視圖。圖27中，為了容易瞭解，而將導電性圖案22附加斜線之陰影線來顯示。此時之導電性圖案22係構成，其單一種類之幾何學形狀之矩形圖案形狀31a在x方向及y方向上隔以圖案間隔 $d1x, d1y$ 而行列狀地

規矩配置。圖1所示之圖案層15之導電性圖案22包含：放射形圖案30及矩形圖案31，但是圖25之圖案層15之導電性圖案22僅包含矩形圖案31。

矩形圖案形狀31a係正方形狀，x方向之長度 b_{1x} 與y方向之長度 b_{1y} 相等，如為21.0 mm，且角部之曲率半徑R2選擇為10.0 mm。此外，在x方向及y方向上鄰接之各圖案形狀59之相互間隔之第二圖案間隔中，x方向之間隔 d_{1x} 與y方向之間隔 d_{1y} 相等，如為1.5 mm。

圖28係顯示構成圖1所示之實施形態中之片體10之其他實施形態之圖案層15之前視圖。圖29係將圖28所示之圖案層15之一部分予以放大顯示之立體圖。圖28及圖29中，為了容易瞭解，而將導電性圖案22附加斜線之陰影線來顯示。此時之導電性圖案22係構成，兩種幾何學形狀之矩形圖案形狀31A, 31B在x方向及y方向上隔以圖案間隔 d_{1x} , d_{1y} 而行列狀地規矩配置。第一及第二矩形圖案31A, 31B在x方向上交互地排列。此外，第一及第二矩形圖案形狀31A, 31B在y方向上交互地配置。

第一及第二矩形圖案形狀31A, 31B係大致正方形狀，第一矩形圖案形狀31A與第二矩形圖案形狀31B，其角部之曲率半徑不同。第一矩形圖案形狀31A角部之曲率半徑R2a選擇比第二矩形圖案形狀31B角部之曲率半徑小。x方向之長度 b_{1x} 與y方向之長度 b_{1y} 相等，如為21.0 mm，角部之曲率半徑R2a, R2b分別選擇為4.0 mm, 7.0 mm。此外，在x方向及y方向上鄰接之各圖案形狀59之相互間隔之第二

圖案間隔中，x方向之間隔 d_{1x} 與y方向之間隔 d_{1y} 相等，如為1.5 mm。即使如此構成，仍可達到相同之效果。

圖30係構成圖1所示之實施形態中之片體10之另外實施形態之圖案層15之前視圖。圖30中，為了容易瞭解，而將導電性圖案22附加斜線之陰影線來顯示。此時之導電性圖案22係構成，其單一種類之幾何學形狀之圖案形狀66在x方向及y方向上隔以圖案間隔 d_{1x} ， d_{1y} 而行列狀地規矩配置。

圖案形狀66係圓形狀，半徑 r 如為13 mm。此外在x方向及y方向上鄰接之各圖案形狀66之相互間隔之圖案間隔中，x方向之間隔 d_{1x} 與y方向之間隔 d_{1y} 相等，如為8 mm。即使如此構成，仍可達到相同之效果。

圖31係構成圖1所示之實施形態中之片體10之另外實施形態之圖案層15之前視圖。圖31中，為了容易瞭解，而將導電性圖案22附加斜線之陰影線來顯示。圖4所示之圖案層15之導電性圖案22包含：放射形圖案30及矩形圖案31，不過，圖31之圖案層15之導電性圖案22僅包含放射形圖案30。即使如此構成，仍可達到相同之效果。

圖32係顯示其他形態之矩形圖案形狀71之前視圖。本實施形態取代圖4、圖16、圖17、圖18、圖19、圖25、圖27、圖28之矩形圖案形狀31a，而使用圖32所示之矩形圖案形狀71。其他構造與圖1所示之實施形態之構造相同。圖4、圖16、圖17、圖18、圖19、圖25、圖27、圖28所示之矩形圖案形狀31a，係面狀圖案，而圖32之矩形圖案形

狀 71 係沿著外周緣而延伸之封閉迴路之線狀(帶狀)圖案。即使如此構成，仍可達到相同之效果。

圖 33 係顯示本發明另外形態之放射形圖案形狀 70 之前視圖。本實施形態取代圖 4、圖 16、圖 17、圖 18、圖 19 及圖 31 所示之放射形圖案形狀 30a，而使用圖 33 所示之放射形圖案形狀 70。其他構造與圖 1 所示之實施形態之構造相同。圖 4、圖 16、圖 17、圖 18、圖 19 及圖 31 所示之放射形圖案形狀 30a，係面狀圖案，而圖 33 之放射形圖案形狀 70 係沿著外周緣而延伸之封閉迴路之線狀(帶狀)圖案。即使如此構成，仍可達到相同之效果。

圖 34 係構成圖 1 所示之實施形態中之片體 10 之另外實施形態之圖案層 15 之前視圖。圖 34 中，為了容易瞭解，而將導電性圖案 22 附加斜線之陰影線來顯示。圖案層 15 係在板狀基底 21 之電磁波入射側之表面上形成金屬製之導電性圖案 22。

導電性圖案 22 在與電磁波入射方向交叉之方向上，具體而言，係垂直於厚度方向，且相互垂直之 x 方向及 y 方向上，於片體 10 之寬廣範圍中，具體而言係涵蓋全體，電性連接而連續地形成。連續導體元件之導電性圖案 22 中形成有複數空孔 80, 81。各空孔 80, 81 具有自包含 1 個四方形之方形之多角形、圓形、角部之外形線為曲線之大致多角形、帶狀地延伸之形狀及此等組合而選出之形狀。帶狀地延伸之形狀係細長延伸之形狀，亦可直線狀地延伸，如亦可如渦卷地延伸成曲線狀，亦可在中途部彎曲。

進一步詳細說明，在導電性圖案22中形成有形狀及尺寸中至少任何一方不同之數種空孔，具體而言係形成：十字形空孔80與方形空孔81。

十字形空孔80係形成十字形狀，複數十字形空孔80相互隔以間隔(以下稱「十字形空孔間隔」) c_{2x} , c_{2y} 而設置。進一步詳細而言，十字形空孔80係以使放射狀地延伸之部分82相互對接，相互對接之放射狀地延伸之部分82隔以十字形空孔間隔 c_{2x} , c_{2y} 。進一步具體說明，如本實施形態之十字形空孔80亦可沿著相互垂直之x方向及y方向形成放射狀之十字形，並在x方向上隔以十字形空孔間隔 c_{2x} ，在y方向上隔以十字形空孔間隔 c_{2y} ，而行列狀地規矩配置。

十字形空孔80係將在x方向上細長延伸之長方形之形狀部分84，與在y方向上細長延伸之長方形之形狀部分85，重疊此等各形狀部分84, 85之圖心，而在交叉部分86直角地交叉之形狀。各形狀部分84, 85於交叉部分86中，在垂直之軸線周圍偏移90度，而具有相同形狀。各形狀部分84, 85之寬度 a_{1y} , a_{1x} 相等，如為8 mm。各形狀部分84, 85之長度 a_{2x} , a_{2y} 相等，如為38 mm。十字形空孔80之十字形空孔間隔中，x方向之間隔 c_{2x} 與y方向之間隔 c_{2y} 相等，如為32 mm。

方形空孔81在被十字形空孔80包圍之區域，自十字形空孔80隔以間隔(以下稱為「十字形方形間隔」) c_{1x} , c_{1y} 而配置，並以佔滿被十字形空孔80包圍之區域之方式設置。進一步詳細而言，方形空孔81將被十字形空孔80包圍之區域

分割成4個部分，而分別配置於各個分割之區域。因此，在被十字形空孔80包圍之1個區域中形成4個方形空孔81。

方形空孔81係對應於被十字形空孔80包圍之區域之形狀，如本實施形態之十字形空孔80係前述之十字形，被十字形空孔80包圍之區域係長方形，且係對應於其之形狀之長方形。各形狀部分84, 85如前述地為相同形狀時，被十字形空孔80包圍之區域成為正方形，方形空孔81成為正方形。

被十字形空孔80包圍之1個區域內之4個十字形空孔80，以邊緣部延伸於x方向及y方向之任何一方之方式配置，且行列狀地並列於x方向及y方向。並列此等4個方形空孔之區域成為四方形，具體而言成為正方形，亦有該區域與十字形空孔80之距離之十字形方形間隔 $c1x$, $c1y$ ，形成在全周相同之形狀。

此種各空孔80, 81之配置，改變觀點來觀察時，係將具有4個方形空孔81與1個十字形空孔80之空孔群作為1個單位，複數單位空孔群排列於與電磁波入射方向交叉之方向，具體而言，係行列狀地並列於x方向及y方向而配置。1個空孔群中，4個方形空孔81行列狀地並列於x方向及y方向，在形成於此等4個方形空孔81間之十字形狀之區域中配置十字形空孔80。

方形空孔81之x方向之尺寸 $b1x$ 與y方向之尺寸 $b1y$ 相等，如為27 mm，十字形空孔80與方形空孔81之十字形方形間隔中，x方向之間隔 $c1x$ 與y方向之間隔 $c1y$ 相等，如為2

mm。此外，被十字形空孔 80 包圍之區域內之 4 個方形空孔 81 之間隔(以下稱為「方形空孔間隔」) c_{3x} ， c_{3y} 中， x 方向之間隔 c_{3x} 與 y 方向之間隔 c_{3y} 相等，如為 4 mm。

因此，導電性圖案 22 具有自以 x 方向上平行之 2 個邊與 y 方向上平行之 2 個邊界定之正方形，將切除前述單位空孔群之形狀之元件部分作為 1 個單位元件部分 101。單位元件部分 101 關於其中心點 P101 係點對稱，並且係在中心點 P101 周圍，每旋轉 90 度成為相同形狀之旋轉對稱。此外，關於通過中心點 P101 而平行於 x 方向之直線係線對稱，並且關於通過中心點 P101 而平行於 y 方向之直線係線對稱。導電性圖案 22 係使複數單位元件部分 101 在 x 方向及 y 方向上平行移動而行列狀地並列之形狀。該形狀亦係交互配置單位元件部分 101 以及與單位元件部分 101 在 x 方向及 y 方向對稱形之對稱單位元件部分成相間狀之形狀。前述單位元件部分 101 亦有之配置間距之 x 方向之尺寸 f_{1x} 及 y 方向之尺寸 f_{1y} 如為 70 mm。十字形空孔 80 及方形空孔 81 係多角形狀，全部之角部分係形成尖銳狀，亦即構成角而形成邊緣狀。即使如此構成，仍可達到相同之效果。

圖 35 係顯示作為本發明另外實施形態，而於圖 34 之圖案層 15 尺寸上構造不同之其他圖案層 15 之前視圖。圖 34 中，為了容易瞭解，而將導電性圖案 22 附加斜線陰影線來顯示。除尺寸上之構造外，與參照圖 33 而說明之構造相同，因此在對應之部分註記相同符號，而僅說明不同部分之尺寸。該圖案層 15 取代圖 3 所示之圖案層 15，可使用於片體

10。各形狀部分84, 85之寬度 a_{1y} , a_{1x} 如為6 mm, 各形狀部分84, 85之長度 a_{2x} , a_{2y} 如為132 mm。十字形空孔間隔 c_{2x} , c_{2y} 如為8 mm。此外方形空孔81之尺寸 b_{1x} , b_{1y} 如為50 mm。十字形方形間隔 c_{1x} , c_{1y} 如為7 mm。此外, 方形空孔間隔 c_{3x} , c_{3y} 如為20 mm。再者, 前述單位元件部分101之尺寸 f_{1x} , f_{1y} 如為140 mm。該圖35所示之導電性圖案22中, 方形空孔81亦相當於等尺寸部分。以下, 等尺寸部分有時使用與方形空孔相同之符號81。

圖36係顯示可用作本發明另外實施形態之其他圖案層15之前視圖。圖36中為了容易瞭解, 而將導電性圖案22附加斜線陰影線來顯示。在與圖34所示之圖案層15對應之部分註記相同符號, 而僅說明不同之構造。該圖案層15取代圖3所示之圖案層15, 可使用於片體10。圖36所示之圖案層15, 其導電性圖案22與圖34所示之導電性圖案22具有不同之形狀。圖36所示之導電性圖案22形成複數空孔120。

各空孔120係全部之內角未達180度之多角形, 亦可為正多角形。本實施形態之各空孔120係四方形, 具體而言係長方形。長方形中包含正方形。進一步詳細說明, 各空孔120係以x方向上平行之兩邊與y方向上平行之兩邊界定之正方形, 該長方形之各空孔120係按照與行列狀不同之指定之規則性來配置。

更具體而言, 導電性圖案22具有自以x方向上平行之兩邊與y方向上平行之兩邊界定之正方形, 形成切下4個長方形(將各空孔120以平行於其一邊之直線分成一半之長方形)

之形狀之單位元件部分101。該單位元件部分101係在前述4個切下部分在單位元件部分101之各邊部分各有1個，而使切下之一邊與單位元件部分101之邊一致之狀態下配置，而以開放於外方之方式分別形成之形狀。再者，4個切下之部分，其中心位置自單位元件部分101各邊之中點，向單位元件部分101之中心位置P101周圍之周方向一方，以相同之偏移量配置於偏移之位置。4個切下之部分與單位元件部分101之邊一致之邊的尺寸，與空孔120鄰接之2個邊中之一方邊之尺寸相等，對單位元件部分101之邊垂直之邊的尺寸，係空孔120之前述鄰接之2個邊中之另一方邊之尺寸之1/2之尺寸。

該單位元件部分101關於其中心點P101係點對稱，並且係在中心點P101周圍，每旋轉90度成為相同形狀之旋轉對稱。導電性圖案22具有將複數單位元件部分101以及與單位元件部分101關於x方向及y方向係對稱形之複數對稱單位元件部分101a，交互並列而形成相間狀之形狀。具有此種形狀之導電性圖案22之圖案層15，可取代圖3所示之圖案層15而同樣地使用，且可包含該圖35所示之圖案層15而構成片體10。單位元件部分101之x方向之尺寸 $f1x$ 及y方向之尺寸 $f1y$ 如為70 mm。

以下說明圖36所示之圖案層15更具體之構造，各空孔120係正方形。形成於單位元件部分101之各切下部分成為長邊與空孔120之一邊相同尺寸，短邊為空孔120之一邊之1/2尺寸之長方形。各切下部分使長邊與單位元件部分101

之邊一致而配置。藉由形成將形成此種各切下部分之單位元件部分101與對稱之對稱單位元件部分101a並列成前述相間狀之形狀，可獲得形成正方形狀之複數空孔120之圖案層15。各空孔120之x方向之尺寸 $g1x$ 及y方向之尺寸 $g1y$ 相同，如為40 mm。本實施形態各空孔120相當於等尺寸部分。以下，有時等尺寸部分使用與空孔120相同之符號。

圖37係顯示可用作本發明另外實施形態之其他圖案層15之前視圖。圖37中為了容易瞭解，而將導電性圖案22附加斜線陰影線來顯示。在與圖34所示之圖案層15對應之部分註記相同符號，而僅說明不同之構造。該圖案層15取代圖3所示之圖案層15，可使用於片體10。圖37所示之圖案層15，其導電性圖案22與圖34所示之導電性圖案22具有不同之形狀。

圖37所示之導電性圖案22形成複數空孔121。各空孔121係複數線段狀部分垂直彎曲而連接，大致形成C字形之2個C字形部125，使凹下之側相對而配置，各C字形部之中央部以直線狀之連結部126連結之形狀。此種形狀之各空孔121係以一方之C字形部125，關於其他空孔121之連結部126，在嵌入一方側之凹部之狀態下，彼此纏繞而按照指定之規則性配置而形成。各C字形部125之各線段狀部分及各連結部126在x方向或y方向上平行。

更具體而言，導電性圖案22具有自以x方向上平行之兩邊與y方向上平行之兩邊界定之正方形，將4個鉤狀之部分向周方向並列而切成渦卷狀形狀之單位元件部分101。各

鉤之部分係5個線段狀部分以4個彎曲部連結，隨著構成單位元件部分101之內方，而線段狀部分之尺寸變小之形狀，最外側之線段狀部分沿著單位元件部分101之邊而配置，並在單位元件部分101中向外方開放。單位元件部分101以形成在中心點P101使交叉部一體之卍字形部分之方式，而形成使x方向或y方向上平行之複數(本實施形態中為5個)線段狀部分垂直地彎曲而連結，向周方向一方迴旋，並向半徑方向外方擴大之渦卷狀。

該單位元件部分101關於其中心點P101係點對稱，並且係在中心點P101周圍，每旋轉90度成為相同形狀之旋轉對稱。導電性圖案22具有交互並列複數單位元件部分101以及與單位元件部分101在x方向及y方向對稱形之複數對稱單位元件部分101a而形成相間狀之形狀。如此，導電性圖案22係具有彼此連接之複數渦卷狀部分之形狀。具有此種形狀之導電性圖案22之圖案層15，可取代圖3所示之圖案層15而同樣地使用，可包含該圖37所示之圖案層15而構成片體10。單位元件部分101之x方向之尺寸 $f1x$ 及y方向之尺寸 $f1y$ 如為63 mm。

此外，從不同觀點觀察時，圖37所示之導電性圖案22，如著眼於被虛擬線包圍而顯示之區域S1，係以延伸於一個方向之複數不同尺寸部分127，向與一個方向交叉之方向並列之方式，而形成各空孔121。區域S1中各個不同尺寸部分127向x方向延伸，並向y方向並列。導電性圖案22中存在複數與該區域S1相同形狀之區域，並且存在複數具有

區域S1旋轉90度之形狀之區域。

如此，圖37所示之導電性圖案22係沿著與電磁波之入射方向交叉之面而電性連接，而連續地形成之連續導體元件，且形成複數空孔121。各空孔121具有在沿著平面而配置導電性圖案22之狀態下，彼此正交之2個方向之尺寸不同之不同尺寸部分127。各不同尺寸部分127向前述2個方向之尺寸中較小尺寸之方向並列而配置。此時前述2個方向係x方向及y方向。各不同尺寸部分127之前述2個方向之尺寸中較小一方之尺寸之各不同尺寸部分127的寬度尺寸 w_{127} 如為4 mm，前述不同尺寸部分127之前述2個方向之尺寸中較大一方之尺寸之各不同尺寸部分127的長度尺寸為前述寬度尺寸 w_{127} 之2倍以上。

圖38係顯示可用作本發明另外實施形態之其他圖案層15之前視圖。圖38中，為了容易瞭解，而將導電性圖案22附加斜線陰影線來顯示。與圖34所示之圖案層15對應之部分註記相同符號，而僅說明不同之構造。該圖案層15可取代圖3所示之圖案層15而用於片體10。圖38所示之圖案層15，其導電性圖案22具有與圖34所示之導電性圖案22不同之形狀。

圖38所示之導電性圖案22形成複數空孔130。各空孔130之彼此隔以間隔而平行地延伸之2個直線狀之端壁部131，在各中央部藉由直線狀之連結部132而連結，全體具有I字形之形狀。此種形狀之各空孔130，其一方端壁部131，在關於其他空孔130之連結部132，而嵌入一方側之凹部之狀

態下，按照指定之規則性配置而形成。各端壁部 131 及各連結部 132 係在 x 方向或 y 方向上平行。

更具體而言，導電性圖案 22 具有自以 x 方向上平行之兩邊與 y 方向上平行之兩邊界定之正方形，在將 4 個 L 字形之部分，其一方之直線部分沿著前述正方形之各邊而配置，並向外方開放之狀態下，向周方向並列而切成渦卷狀形狀之單位元件部分 101。單位元件部分 101 形成在中心點 P101，自其中心一致之正方形之基部，垂直地彎曲複數 (本實施形態為 2 個) 線段地連結，向周方向一方迴旋，並向半徑方向外方擴大之渦卷狀。

該單位元件部分 101 關於其中心點 P101 係點對稱，並且係在中心點 P101 周圍，每旋轉 90 度成為相同形狀之旋轉對稱。導電性圖案 22 具有交互並列複數單位元件部分 101 以及與單位元件部分 101 在 x 方向及 y 方向對稱形之複數對稱單位元件部分 101a 而形成相間狀之形狀。如此，導電性圖案 22 係具有彼此連接之複數渦卷狀部分之形狀。具有此種形狀之導電性圖案 22 之圖案層 15，可取代圖 3 所示之圖案層 15 而同樣地使用，可包含該圖 38 所示之圖案層 15 而構成元件接收機構 100。單位元件部分 101 之 x 方向之尺寸 $f1x$ 及 y 方向之尺寸 $f1y$ 如為 41 mm。

此外，從不同觀點觀察時，圖 38 所示之導電性圖案 22，如著眼於被虛擬線包圍而顯示之區域 S2，係以延伸於一個方向之複數不同尺寸部分 137，向與一個方向交叉之方向並列之方式，而形成各空孔 130。區域 S2 中各個不同尺寸

部分137向x方向延伸，並向y方向並列。導電性圖案22中存在複數與該區域S2相同形狀之區域，並且存在複數具有區域S2旋轉90度之形狀之區域。

如此，圖38所示之導電性圖案22係沿著與電磁波之入射方向交叉之面而電性連接，而連續地形成之連續導體元件，且形成複數空孔130。各空孔130具有在沿著平面而配置導電性圖案22之狀態下，彼此正交之2個方向之尺寸不同之不同尺寸部分137。各不同尺寸部分137向前述2個方向之尺寸中較小尺寸之方向並列而配置。此時前述2個方向係x方向及y方向。各不同尺寸部分137之前述2個方向之尺寸中較小一方之尺寸之各不同尺寸部分137的寬度尺寸w137如為3 mm，前述不同尺寸部分137之前述2個方向之尺寸中較大一方之尺寸之各不同尺寸部分137的長度尺寸為前述寬度尺寸w137之2倍以上。

圖39係顯示可用作本發明另外實施形態之其他圖案層15之前視圖。圖39中，為了容易瞭解，而將導電性圖案22附加斜線陰影線來顯示。與圖34所示之圖案層15對應之部分註記相同符號，而僅說明不同之構造。該圖案層15可取代圖3所示之圖案層15而用於片體10。圖39所示之圖案層15，其導電性圖案22具有與圖34所示之導電性圖案22不同之形狀。

圖39所示之導電性圖案22形成複數空孔135。各空孔135係細長之長方形狀，且以帶狀，亦即構成條紋狀，按照指定之規則性配置而形成。各空孔135係平行於x方向或y方

向。更具體而言，導電性圖案22具有自以x方向上平行之兩邊與y方向上平行之兩邊界定之正方形，切下配置成帶狀之複數空孔135之形狀之單位元件部分101。在單位元件部分101中，將單位元件部分101以在中心點P101正交之平行於x方向之直線與平行於y方向之直線分割成4個區域，在配置於一方之對角線方向之2個區域，複數(本實施形態為6個)空孔135在x方向上平行且帶狀地大致均等地配置而形成，在另一方對角線方向上配置之2個區域，複數(本實施形態為6個)空孔135在y方向上平行且帶狀地大致均等地配置而形成。

該單位元件部分101關於其中心點P101係點對稱，並且係在中心點P101周圍，每旋轉90度成為相同形狀之旋轉對稱。導電性圖案22具有行列狀地並列而形成複數單位元件部分101之形狀。該形狀亦係交互地配置單位元件部分101以及與單位元件部分101在x方向及y方向對稱形之對稱單位元件部分成相間狀之形狀。此外，導電性圖案22亦係在自x方向上平行之兩邊與y方向上平行之兩邊界定之正方形區域，將延伸於x方向之6個空孔135並列於y方向而形成之部分，與在同樣之正方形區域，將延伸於y方向之6個空孔135並列於x方向而形成之部分，交互並列地配置成相間狀之形狀。具有此種形狀之導電性圖案22之圖案層15，可取代圖4所示之圖案層15而同樣地使用，可包含此種圖14所示之圖案層15而構成元件接收機構100。單位元件部分101之x方向之尺寸 $f1x$ 及y方向之尺寸 $f1y$ 如為129 mm。

此外，從不同觀點觀察時，圖39所示之導電性圖案22，如著眼於被虛擬線包圍而顯示之區域S3，係以延伸於一個方向之複數不同尺寸部分，向與一個方向交叉之方向並列之方式，而形成各空孔135。圖39之構造，各空孔135分別相當於不同尺寸部分。區域S3中，各不同尺寸部分之各空孔135向x方向延伸，並向y方向並列。導電性圖案22中存在複數與該區域S3相同形狀之區域，並且存在複數具有區域S3旋轉90度之形狀之區域。

如此，圖39所示之導電性圖案22係沿著與電磁波之入射方向交叉之面而電性連接，而連續地形成之連續導體元件，且形成複數空孔135。各空孔135相當於在沿著平面而配置導電性圖案22之狀態下，彼此正交之2個方向之尺寸不同之不同尺寸部分。以下，不同尺寸部分有時使用與各空孔135相同之符號135。各不同尺寸部分之各空孔135係向前述2個方向之尺寸中較小尺寸之方向並列而配置。此時，前述2個方向係x方向及y方向。各空孔135之前述兩個方向之尺寸中較小一方之尺寸之各空孔135之寬度尺寸w135如為6 mm，空孔135之前述兩個方向之尺寸中較大一方之尺寸之空孔135之長度尺寸為前述寬度尺寸w135之2倍以上。

圖40係顯示放大構成圖1所示之實施形態中之片體10之其他實施形態之圖案層15之一部分之前視圖。圖41係放大圖40之一部分而顯示之圖案層15之前視圖。圖40及圖41中，為了容易瞭解，而將導電性圖案22附加斜線之陰影線

來顯示。該圖案層15係取代圖1所示之前述之圖案層15而使用之圖案層，且與圖1所示之前述之圖案層15類似，在對應之部分註記相同之參照符號，而省略重複之說明。圖40之圖案層15與圖1之圖案層15，各導電性圖案22之形狀及尺寸不同。圖40之導電性圖案22具有：複數放射形圖案30及複數大致方形圖案31。

各放射形圖案30分別形成放射形狀，複數放射形圖案30相互隔以間隔而設置。各放射形圖案30形成相互地在虛擬之一個平面上正交之沿著x方向及y方向之放射狀的大致十字形，並在x方向及y方向上行列狀地規矩地整齊配置。各放射形圖案30係將圖41中以虛擬線顯示之成為基礎之十字形(以下稱為「基礎十字形」)40之交叉部分36中之4個角部41形成曲線狀，具體而言係形成圓弧狀之形狀。基礎十字形40係細長延伸於x方向之第一長方形部分34與細長延伸於y方向之第二長方形部分35，重疊此等各長方形部分34, 35之中心，而在交叉部分36直角地交叉之形狀。各長方形部分34, 35在交叉部分36，於垂直之軸線周圍偏差90度，而具有相同形狀。在此種基礎十字形40中，係以交叉部分36之4個角部41分別收納各第一大致直角三角形42之角部之方式而設計4個第一大致直角三角形42之形狀。各第一大致直角三角形42係大致直角等腰三角形，且係與直角之角部相對之斜邊朝向直角之角部而凹下地彎曲成圓弧狀之形狀。各放射形圖案30係4次旋轉對稱，且關於各長方形部分34, 35之中心為點對稱，通過各長方形部分34, 35之中

心，於各長方形部分之長邊平行之2個直線係分別線對稱，通過各長方形部分34, 35之中心，與各長方形部分之長邊平行之2個直線偏差45度之2個直線係線對稱。

各大致方形圖案31在被放射形圖案30包圍之區域，自放射形圖案30隔以間隔而配置，並以佔滿被放射形圖案30包圍之區域之方式分別配置。藉由組合：x方向上鄰接之2個放射形圖案30，與此等2個放射形圖案30中，在y方向之任何一方鄰接之2個放射形圖案30之4個放射形圖案30包圍之區域係大致正方形。該區域中，以嵌入之方式配置1個大致方形圖案31。各大致方形圖案31形成與被前述4個放射形圖案30包圍之區域形狀類似之形狀。

各放射形圖案30係前述之大致十字形，且被各放射形圖案30包圍之各區域係長方形之各角部形成圓弧狀之圓角四方形。成為該圓角四方形之基礎之長方形包含：長邊與短邊之尺寸不同之矩形及長邊與短邊之尺寸相同之正方形。本實施形態中，被各放射形圖案30包圍之各區域係大致正方形之圓角四方形，且各大致方形圖案31係大致正方形之圓角四方形。

各大致方形圖案31係將基礎正方形25之4個角部26變更成圓弧狀之形狀。各大致方形圖案31係自基礎正方形25，除去以直角之角部收納於基礎正方形25之角部之方式而配置之4個第二大致直角三角形27之形狀。各第二大致直角三角形27係大致直角等腰三角形，且係與直角之角部相對之斜邊朝向直角之角部凹下而彎曲成圓弧狀之形狀。各大

致方形圖案31係以基礎正方形25之中心與連結其周圍4個放射形圖案30之基礎十字形之中心而形成之正方形之中心一致，且基礎正方形25之各邊以延伸於x方向及y方向之任何一方之方式配置。各大致方形圖案31係4次旋轉對稱，而基礎正方形25之中心為點對稱，基礎正方形25之2個對角線分別為線對稱，通過基礎正方形25中心，而平行於任何之邊之2個直線分別為線對稱。

形成具有此種放射形圖案30與大致方形圖案31之各圖案12之圖案層15，假設圖案層15全部區域之面積為1時，具有形成各導電性圖案22之區域之面積(以下稱為「圖案面積」)為0.6以上之面積比。

第一長方形部分34之寬度 $a1y$ 與第二長方形部分35之寬度 $a1x$ 彼此相等，如為0.05 mm以上，10 mm以下，第一長方形部分34之長度 $a2x$ 與第二長方形部分35之長度 $a2y$ 彼此相等，如為1 mm以上，100 mm以下。夾著第一大致直角三角形42之直角之兩邊長度，亦即兩邊中之沿著x方向之邊的長度 $a3x$ 與沿著y方向之邊的長度 $a3y$ 彼此相等，如為0.1 mm以上，50 mm以下，第一大致直角三角形42之斜邊之曲率半徑 $R1$ 如為1 mm以上，100 mm以下。分別連結第一大致直角三角形42之斜邊之圓弧中心點與第一大致直角三角形42之斜邊兩端之2個直線構成之角度 $\theta3$ 為5度以上，45度以下。在x方向鄰接之2個放射形圖案30之各第一長方形部分34間之距離 $c2x$ ，與y方向上鄰接之2個放射形圖案30之各第二長方形部分35間之距離 $c2y$ 彼此相等，如為0.1

mm以上，100 mm以下。

此外，基礎正方形25之x方向之尺寸 b_{1x} 與y方向之尺寸 b_{1y} 彼此相等，如為1 mm以上，100 mm以下。此等基礎正方形25之各尺寸 b_{1x} ， b_{1y} 係大致方形圖案31之x方向尺寸及y方向尺寸。夾著第二大致直角三角形27之直角之兩邊長度，亦即兩邊中之沿著x方向之邊的長度 b_{2x} 與沿著y方向之邊的長度 b_{2y} 彼此相等，如為0.1 mm以上，50 mm以下，第二大致直角三角形27之斜邊之曲率半徑 R_2 為1 mm以上，100 mm以下。

此外，放射形圖案30與大致方形圖案31間之間隙(以下稱為「放射方形間之間隙」)之寬度尺寸 c_1 ，在最小寬度尺寸 c_{1min} 至最大寬度尺寸 c_{1max} 之間，於間隙之延伸方向上連續地變化。放射方形間之間隙之最小寬度尺寸 c_{1min} ，係至放射形圖案30之各長方形部分34，35之長度方向之端中之大致方形圖案31之尺寸，如為0.1 mm以上，20 mm以下。放射方形間之間隙之最大寬度尺寸 c_{1max} ，係沿著將各大致直角三角形42，27之直角予以二等分之直線位置之尺寸，如為0.5 mm以上，50 mm以下。

如此，放射方形間之間隙之寬度尺寸 c_1 ，在其間隙之延伸方向上連續地變化。放射方形間之間隙之寬度尺寸 c_1 之變化率 Δc_1 如為0.001以上，10以下。放射方形間之間隙之寬度尺寸 c_1 之變化率 Δc_1 ，係沿著放射形圖案30之邊緣每單位尺寸之放射方形間之間隙之寬度尺寸 c_1 之變化量。此外，本實施形態之變化率 Δc_1 並非相同，係隨著自最小寬

度尺寸 c_{lmin} 之位置向最大寬度尺寸 c_{lmax} 之位置而逐漸變小。

變化率 Δc_1 以公式 (1) 來表示。公式 (1) 中之係數 k ，以公式 (2) 表示。

[數 1]

$$\Delta c_1 = \frac{c_{lmax} - c_{lmin}}{\frac{k}{2}} \quad \dots(1)$$

$$k = \left(\frac{a_{2x} - a_{1x}}{2} - a_{3x} \right) + \left(\frac{a_{2y} - a_{1y}}{2} - a_{3y} \right) + \left(\frac{2\pi R_1}{360} \right) \quad \dots(2)$$

作為片體 10 之吸收對象之電磁波頻率為 UHF 頻帶時，各長方形部分 34, 35 之寬度 a_{1x} , a_{1y} 如為 1 mm，各長方形部分 34, 35 之長度 a_{2x} , a_{2y} 如為 20 mm，夾著第一大致直角三角形 42 直角之兩邊長度 a_{3x} , a_{3y} 如為 6.5 mm，斜邊之曲率半徑 R_1 為 6.5 mm。作為片體 10 之吸收對象之電磁波頻率為 UHF 頻帶時，基礎正方形 25 之尺寸 b_{1x} , b_{1y} 如為 25 mm，夾著第二大致直角三角形 27 直角之兩邊長度 b_{2x} , b_{2y} 如為 10.5 mm，斜邊之曲率半徑 R_2 為 10.5 mm。作為片體 10 之吸收對象之電磁波頻率為 UHF 頻帶時，放射方形間之間隙之寬度尺寸 c_1 之最小寬度尺寸 c_{lmin} 如為 0.5 mm，最大寬度尺寸 c_{lmax} 如為 2 mm，變化率 Δc_1 如為 0.15。作為片體 10 之吸收對象之電磁波頻率為 UHF 頻帶時，放射形圖案間之間隔 c_{2x} , c_{2y} 如為 7 mm。

作為片體 10 之吸收對象之電磁波頻率為 2.4 GHz 頻帶

時，各長方形部分34, 35之寬度 a_{1x} , a_{1y} 如為0.5 mm，各長方形部分34, 35之長度 a_{2x} , a_{2y} 如為17.5 mm，夾著第一大致直角三角形42直角之兩邊長度 a_{3x} , a_{3y} 如為5 mm，斜邊之曲率半徑 R_1 為5 mm。作為片體10之吸收對象之電磁波頻率為2.4 GHz頻帶時，基礎正方形25之尺寸 b_{1x} , b_{1y} 如為20.5 mm，夾著第二大致直角三角形27直角之兩邊長度 b_{2x} , b_{2y} 如為8 mm，斜邊之曲率半徑 R_2 為8 mm。作為片體10之吸收對象之電磁波頻率為2.4 GHz頻帶時，放射方形間之間隙之寬度尺寸 c_1 之最小寬度尺寸 c_{1min} 如為0.5 mm，最大寬度尺寸 c_{1max} 如為1.7 mm，變化率 Δc_1 如為0.14。作為片體10之吸收對象之電磁波頻率為2.4 GHz頻帶時，放射形圖案間之間隔 c_{2x} , c_{2y} 如為2.5 mm。

具備形成包含此種放射形圖案30與大致方形圖案31之各導電性圖案22之圖案層15之片體10，可達到與具備前述圖3之圖案層15之片體10相同之效果。此外，圖40及圖41之圖案層15，各導電性圖案22中，至少一部分之圖案具有包含曲線部分之外形形狀。本實施形態全部之導電性圖案22具有包含曲線部分之外形形狀。該導電性圖案22接收電磁波時之共振電流在曲線狀部分順利地流動。

此外，本發明之其他實施形態之片體10之疊層構造，亦可為圖1以外之疊層構造。

圖42係顯示本發明另外實施形態之片體10a之剖面圖。片體10a如圖42所示，可構成自電磁波入射側起依序堆疊：第一貯藏體層14、圖案層15、第二貯藏體層13、反射

區域形成層 12 及貼合層 11。第一貯藏體層 14、圖案層 15、第二貯藏體層 13、反射區域形成層 12 及貼合層 11 之各層與前述之構造相同。即使如此構成，仍可達到相同之效果。圖 42 之形態中，在與圖 1 對應之構造上註記相同符號。本實施形態中，第一及第二貯藏體層 14, 13 可使用同樣之貯藏體層，亦可為相同之貯藏體層，亦可為不同之貯藏體層。貯藏體層不限於第一及第二，亦可為數層之疊層。可為電介質層，亦可為磁性體層，亦可為複合此等者。亦可為單層者如後述之圖 44 所示。

圖 43 係顯示本發明另外實施形態之片體 10b 之剖面圖。片體 10b 如圖 43 所示，可依序堆疊：第一貯藏體層（如第三貯藏體層 130）、圖案層 15、第二貯藏體層（如第一貯藏體層 14）、第三貯藏體層（如第二貯藏體層 13）、反射區域形成層 12 及貼合層 11 而構成。第三貯藏體層 130 與第一及第二貯藏體層 14, 13 同樣地係貯藏體層，可為介電材亦可為磁性材。圖案層 15、第一貯藏體層 14、第二貯藏體層 13、反射區域形成層 12 及貼合層 11 之各層與前述之實施形態相同。圖 43 之形態中，在與圖 1 對應之構造上註記相同之符號。本實施形態中，第一及第二貯藏體層 14, 13 與第三貯藏體層 130，可使用同樣之貯藏體層，可為同一個貯藏體層，亦可為不同之貯藏體層。

圖 44 係顯示本發明另外實施形態之片體 10c 之剖面圖。片體 10c 如圖 44 所示，可構成自電磁波入射側起依序堆疊：圖案層 15、貯藏體層 208 及反射區域形成層 12。圖案

層 15 及反射區域形成層 12 之各層與前述之構造相同，此外，貯藏體層 208 如前述，係包含非導電性之電介質層及/或磁性體層之層，即使如此構成，仍可達到相同之效果。圖 44 之形態中，在與圖 1 對應之構造上註記相同符號。本實施形態中，貯藏體層 208 可藉由前述各貯藏體層 14, 13 等來實現。

此外，前述各形態之構造中，亦可將各貯藏體層 14, 13, 20, 208 分別予以多層化。此外，各形態之構造中，各層 12~16, 20, 208 亦可為經由接合劑層及支撐體(PET膜等)而堆疊者，此種構造亦可以在設於各層間之接合劑層中配合介電材料及磁性材料之任何一方，而具有貯藏效果之方式構成。特別是反射區域形成層 12 之近旁係磁場強之區域，而可配置由磁性材料構成之層或配合磁性材料之層。

本發明之其他實施形態，係片體不含前述各種實施形態中之反射區域形成層 12，此種不含反射區域形成層 12 之片體亦可構成在與第二貯藏體層 13 或貯藏體層 208 之電磁波入射側(圖 1、圖 42、圖 43 及圖 44 之上方)之相反側(圖 1、圖 42、圖 43 及圖 44 之下方)之表面部，設於具有電磁波遮蔽性能之妨礙通信構件 57 之面上。妨礙通信構件 57 如亦可具有與反射區域形成層 12 相同之構造，如亦可藉由金屬板等來實現，此時達到與設置反射區域形成層 12 之構造相同之效果。

本發明主要說明用作無線標籤之情況，若為用於無線通信之資料載體裝置時，與標籤、讀取器、讀取器/寫入器

無關，係附加於天線體或與天線一體化，最大限度排除妨礙通信構件之影響，而可獲得通信改善效果。

以下說明實施例及比較例之構造及性能評估結果。以下之說明僅係本發明之具體性例示，而本發明並不限定於此。

表1彙整實施例1~6及比較例1及2之各構造與評估結果來顯示。表1表示有無片體、圖案形狀、片體之厚度及能否進行通信(可否通信)。

[表 1]

	有無片體	圖案形狀	片之厚度 (mm)	可否通信
實施例1	有	圖19	3.0	○
實施例2	有	圖28	3.0	○
實施例3	有	圖25	3.0	○
實施例4	有	圖3	3.0	○
實施例5	有	圖3	2.7	○
實施例6	有	圖3	2.1	○
比較例1	無	-	-	×
比較例2	無	-	2.0	×

○：通信距離5 cm以上 ×：通信距離5 cm以下

表2彙整各實施例1~6中之第一及第二貯藏體層14,13之構造而顯示。將第一貯藏體層14作為貯藏體層，將第二貯藏體層13作為電介質層。表2顯示第一及第二貯藏體層

14,13各層之厚度、複數相對介電常數之實數部 ϵ' 及虛數部 ϵ'' 以及複數相對磁導率之實數部 μ' 及虛數部 μ'' 。

[表 2]

實施例	相關圖式 (圖案 形狀)	各層名稱	厚度	材料	ϵ'	ϵ''	μ'	μ''
1	圖19	第一貯藏體層	0.5 mm	SBS	13.6	1.3	1.4	0.5
		第二貯藏體層	2.3 mm	SBS	3.5	0.0	1.0	0.0
2	圖28	第一貯藏體層	0.3 mm	PVC	21.6	1.0	1.2	0.3
		第二貯藏體層	1.8 mm	PVC	4.0	0.1	1.0	0.0
3	圖25	第一貯藏體層	0.5 mm	SBS	15.6	0.6	1.3	0.5
		第二貯藏體層	2.0 mm	SBS	4.6	0.1	1.0	0.0
4	圖3	第一貯藏體層	1.0 mm	SBS	12.3	0.7	1.3	0.5
		第二貯藏體層	1.75 mm	SBS	4.6	0.1	1.0	0.0
5	圖3	第一貯藏體層	0.5 mm	SBS	15.6	0.6	1.3	0.5
		第二貯藏體層	2.0 mm	SBS	4.6	0.1	1.0	0.0
6	圖3	第一貯藏體層	0.4 mm	PVC	25.8	1.3	1.2	0.3
		第二貯藏體層	1.7 mm	PVC	3.5	0.0	1.0	0.0

作為性能評估而進行讀寫器111與標籤之通信試驗。圖45及圖46係模式顯示通信試驗之狀態圖。實施例係在不銹鋼板之金屬板110之厚度方向之一個表面上貼合具有片體10之標籤50，比較例則係在相同之金屬板110之厚度方向之一個表面上直接貼合標籤本體54。選擇金屬板110之一

個表面充分大於標籤50及標籤本體54之厚度方向之一個表面，形成一邊為150 mm之正方形。在金屬板110一個表面之中央部貼合標籤50或標籤本體54。通信試驗中，可通信時，在表1之可否通信欄中顯示符號「○」，無法通信時，在表1之可否通信欄中顯示符號「×」。

靠近標籤本體54，藉由讀寫器111進行無線通信，而進行可否通信之實驗。讀寫器111與標籤本體54之距離L，為實際使用中，標籤本體54與讀寫器111進行無線通信時必要最低限度之距離(必要最低距離)L。用於無線通信之電磁波頻率2.4 GHz頻帶。此外，在讀寫器111與標籤本體54之間介有空氣。

(實施例1)

圖案層15及反射區域形成層12係使用厚度為100 μm 之鋁蒸鍍聚對苯二甲酸乙二醇酯(Polyethylene Terephthalate：簡稱為PET)。圖案層15及反射區域形成層12中之鋁層之層厚為100 μm 。圖案層15係在PET中蒸鍍鋁而形成鋁層，藉由對該鋁層進行蝕刻處理予以圖案化，形成圖19所示之圖案形狀來製作。第一貯藏體層14係藉由在SBS(苯乙烯·丁二烯·苯乙烯共聚物)樹脂100重量部中，於介電材料中添加碳黑35重量部，於磁性材料中添加鐵氧體205重量部及其他分散劑(不使用磁性材)而攪拌，擠壓成形為片狀之1 mm厚之片而形成。第二貯藏體層13係藉由在SBS中攪拌紅磷及氫氧化鎂，形成難燃化之厚度為1.75 mm之片而形成。貼合層11之厚度為0.15 mm，並藉由丙烯酸基共聚樹脂

而形成。將此等藉由接合劑而依序堆疊圖案層15、第一貯藏體層14、第二貯藏體層13及反射區域形成層12，並在反射區域形成層12上堆疊貼合層11，將此等之各層裁斷成20 mm×80 mm之尺寸，來製作總厚度為3 mm之立方體形狀之片體10。圖案層15之導電性圖案22，於x方向為長度方向，y方向為寬度方向時，矩形圖案形狀31a在寬度方向之中央分別對準圖心而排列於長度方向，放射形圖案形狀30a之一部分配置於矩形圖案形狀31a之周圍。貼合所製作之片體10與標籤本體54來製作標籤50。

另外，圖案層15之導電性圖案22為 $a1x=a1y=2.5$ mm， $a2x=a2y=16$ mm， $c1x=c1y=1.0$ mm， $c2x=c2y=1.0$ mm， $b1x=b1y=12.5$ mm， $c1x=c1y=1.0$ mm。

(實施例2)

圖案層15及反射區域形成層12使用厚度為100 μ m之鋁蒸鍍聚對苯二甲酸乙二醇酯(PET)。圖案層15及反射區域形成層12中之鋁層之層厚為0.05 μ m。圖案層15藉由在PET上蒸鍍鋁而形成鋁層，藉由將該鋁層進行蝕刻處理予以圖案化，形成圖28所示之圖案形狀來製作。第一貯藏體層14藉由添加PVC(株式會社KANEKA，KS1700)樹脂100重量部、DOP[鄰苯二甲酸二辛酯(鄰苯二甲酸二乙基己基)]1,2 Benzenedicarboxylic acid bis(2-ethylhexyl)ester]80重量部、介電材料中添加石墨43重量部、磁性材料中添加鐵氧體125重量部、及另外添加碳酸鈣予以攪拌，擠壓成形為片狀之0.3 mm厚之片而形成。第二貯藏體層13係藉由在

SBS中攪拌紅磷及氫氧化鎂，形成難燃化之厚度為1.8 mm之片而形成。貼合層11之厚度為0.15 mm，並藉由丙烯酸共聚樹脂而形成。將此等藉由接合劑而依序堆疊圖案層15、第一貯藏體層14、第二貯藏體層13及反射區域形成層12，並在反射區域形成層12上堆疊貼合層11，將此等之各層裁斷成20 mm×80 mm之尺寸，來製作總厚度為2.1 mm之立方體形狀之片體10。

另外，圖案層15之導電性圖案22為 $b1x=b1y=21.0$ mm， $R2a=7.0$ mm， $R2b=4.0$ mm， $d1x=d1y=1.5$ mm。圖案層15之導電性圖案22，於x方向為長度方向，y方向為寬度方向時，矩形圖案形狀31a在寬度方向之中央分別對準圖心而排列於長度方向。

(實施例3)

圖案層15形成顯示於圖22之圖案形狀，其他之製作方法與實施例1相同。

另外，圖案層15之導電性圖案22為 $b1x=b1y=21.0$ mm， $d1x=d1y=1.5$ mm。圖案層15之導電性圖案22，於x方向為長度方向，y方向為寬度方向時，矩形圖案形狀31a在寬度方向之中央分別對準圖心而排列於長度方向。

(實施例4)

圖案層15形成顯示於圖3之圖案形狀，其他之製作方法與實施例1相同。

另外，圖案層15之導電性圖案22為 $a1x=a1y=1.0$ mm， $a2x=a2y=17.5$ mm， $a3x=a3y=7.5$ mm， $c1x=c1y=1.5$ mm，

$c2x=c2y=7.0$ mm, $b1x=b1y=20.5$ mm, $c1x=c1y=1.5$ mm, $R1=7.5$ mm, $R2=7.0$ mm。圖案層 15 之導電性圖案 22, 於 x 方向為長度方向, y 方向為寬度方向時, 矩形圖案形狀 31a 在寬度方向之中央分別對準圖心而排列於長度方向, 放射形圖案形狀 30a 之一部分配置於矩形圖案形狀 31a 之周圍。

(實施例 5)

圖案層 15 及反射區域形成層 12 係使用厚度為 100 μm 之鋁蒸鍍聚對苯二甲酸乙二醇酯 (PET)。圖案層 15 及反射區域形成層 12 中之鋁層之層厚為 0.05 μm 。圖案層 15 係在 PET 中蒸鍍鋁而形成鋁層, 藉由對該鋁層進行蝕刻處理予以圖案化, 形成圖 3 所示之圖案形狀來製作。第一貯藏體層 14 係藉由在 SBS 樹脂 100 重量部中, 於介電材料中添加石墨 55 重量部, 於磁性材料中添加鐵氧體 213 重量部及其他分散劑而攪拌, 擠壓成形為片狀之 0.5 mm 厚之片而形成。第二貯藏體層 13 係藉由在 SBS 中攪拌紅磷及氫氧化鎂, 形成難燃化之厚度為 2.0 mm 之片而形成。貼合層 11 之厚度為 0.15 mm, 並藉由丙烯酸基共聚樹脂而形成。將此等藉由接合劑而依序堆疊圖案層 15、第一貯藏體層 14、第二貯藏體層 13 及反射區域形成層 12, 並在反射區域形成層 12 上堆疊貼合層 11, 將此等之各層裁斷成 20 mm \times 80 mm 之尺寸, 來製作總厚度為 2.7 mm 之立方體形狀之片體 10。

另外, 圖案層 15 之導電性圖案 22 係與實施例 4 相同之尺寸。

(實施例 6)

圖案層 15 及反射區域形成層 12 係使用厚度為 100 μm 之鋁蒸鍍聚對苯二甲酸乙二醇酯 (PET)。圖案層 15 及反射區域形成層 12 中之鋁層之層厚為 0.05 μm 。圖案層 15 係在 PET 中蒸鍍鋁而形成鋁層，藉由對該鋁層進行蝕刻處理予以圖案化，形成圖 3 所示之圖案形狀來製作。第一貯藏體層 14 係藉由添加 PVC 樹脂 100 重量部、DOP 80 重量部、在介電材料中添加石墨 48 重量部、在磁性材料中添加鐵氧體 130 重量部及其他增量材之碳酸鈣而攪拌，擠壓成形為片狀之 0.4 mm 厚之片而形成。第二貯藏體層 13 係藉由在 SBS 中攪拌紅磷及氫氧化鎂，形成難燃化之厚度為 1.7 mm 之片而形成。貼合層 11 之厚度為 0.15 mm，並藉由丙烯基共聚樹脂而形成。將此等藉由接合劑而依序堆疊圖案層 15、第一貯藏體層 14、第二貯藏體層 13 及反射區域形成層 12，並在反射區域形成層 12 上堆疊貼合層 11，將此等之各層裁斷成 20 mm \times 80 mm 之尺寸，來製作總厚度為 2.1 mm 之立方體形狀之片體 10。

另外，圖案層 15 之導電性圖案 22 係與實施例 4 相同之尺寸。

(比較例 1)

與實施例 1~6 相同，將標籤本體 54 直接貼合於金屬板 110 上進行通信測試。

如從表 1 所示之試驗結果之判斷，比較例之標籤本體 54 與讀寫器 111 無法進行通信，而實施例 1~7 之標籤 50 與讀寫器 111 均可進行通信，即使在妨礙通信構件 57 之金屬板 110

之近旁，仍可正常進行無線通信，並可抑制貼合於金屬板110時之通信距離降低。

(比較例2)

將由橡膠鐵氧體(2 mm厚)構成之磁性片裁斷成20 mm×80 mm之尺寸者，插入標籤本體54與金屬板110之間，進行通信測試。通信改善效果低，明顯比本發明之片體10差。

(實施例7)

圖案形狀大致為圖40及圖41所示者，在放射形圖案30與大致方形圖案31之各曲率上附加差異，使2個圖案30, 31之間隔c1連續地改變其差。導電性圖案22之尺寸為 $a1x=a1y=1.0$ mm, $a2x=a2y=20.0$ mm, $b1x=b1y=25$ mm, $c2x=c2y=7.0$ mm, $c1=0.5$ mm以上, 2.5 mm以下, 放射形圖案30中之大致三角形22之曲率半徑 $R1=6.5$ mm, 大致方形圖案31中之角部之曲率半徑 $R2=10.5$ mm。放射形圖案30與大致方形圖案31之間隔c1, 與此等圖案30, 31間之間隙延伸之方向之兩端部比較, 以中間部變大之方式連續變化。

第一貯藏體層14之配合, 係將聚氯乙炔(昭和電工株式會社, ELASLENE301NA)100(phr)、羧基鐵(BASF製EW-1)800(phr)作為基礎, 而添加可塑劑、分散劑及碳酸鈣等。第二貯藏體層13之配合, 與用於第一貯藏體層14者相同, 在聚氯乙炔100(phr)中, 將黑鉛16(phr)作為基礎而添加可塑劑及分散劑等。其構造係圖案層15(鋁蒸鍍PET

膜)、第一貯藏體層 14(2.1 mm)、第二貯藏體層 13(2.5 mm) 及反射區域形成層(鋁蒸鍍PET膜)之疊層。950 MHz頻帶中之材料常數：第一貯藏體層 14 為 $\epsilon'=19.0$ ， $\epsilon''=0.90(\tan\delta\epsilon=0.047)$ ， $\mu'=5.33$ ， $\mu''=1.43(\tan\delta\mu=0.268)$ ，第二貯藏體層 13 為 $\epsilon'=7.9$ ， $\epsilon''=0.13(\tan\delta\epsilon=0.017)$ ， $\mu'=1$ ， $\mu''=0$ ，且均為抑制損失之配合。片體 10 用於 UHF 頻帶時，厚度約 4.6 mm。

圖 47 係顯示以模擬計算實施例 7 之片體 10 之反射損失之結果圖。圖 47 中，橫軸表示頻率，縱軸表示反射損失。本發明之反射損失量之計算如前述，係以電腦模擬來進行。本實施例之圖案構造如前述，係以改變鄰接導電性圖案 22 之角部之曲率半徑，並連續改變導電性圖案 22 間之間隔之形態，進行共振之調整(頻率及 Q)。

將該實施例 7 之片體 10，以在放射形圖案 30 上配置標籤本體 54 之方式，切下成比標籤本體 54 大 1 圈之尺寸，在片體 10 上堆疊 ALIEN 社製之 UHF 頻帶用中間範圍標籤 (ALIEN2004, 89 mm×19 mm)，將其使用 ALIEN 社製讀取器 (ALR-7610-75L，直線偏振使用) 來讀取，而進行試驗。另外，在自由空間中評估前述中間範圍標籤時之通信距離為 2800 mm。表 3 顯示讀取試驗之結果(通信距離測定結果)。表 3 中，比較例 3 及 4 係取代片體 10 而使用發泡體之發泡苯乙烯，亦顯示進行同樣讀取試驗之結果。表 3 中顯示：片體 10 之厚度(片厚)、通信距離及對自由空間通信距離比。該讀取試驗時，妨礙通信構件係使用鋁板，並在鋁板上放

置片體10或發泡體。因此，片厚等於自鋁板至標籤本體54之距離(Gap間隔)。

[表 3]

構造	實施例 7	比較例 3	比較例 4
		發泡苯乙烯	
片厚(Gap間隔) (mm)	5.1	5	10
通信距離 (mm)	2130	590	960
對自由空間通信距離比(%)	76	21	35

使用厚度約5 mm之比較例7之片體10時，顯示2130 mm之通信距離，獲得自由空間時約76%之通信距離。作為比較而使用發泡體進行讀取試驗時之通信距離，為自由空間時之21%，顯示本發明之片體10有大幅之通信距離改善效果。

(實施例8)

圖48係顯示實施例8之片體10之剖面圖，圖49係顯示安裝於實施例8之片體10上之標籤本體54之平面圖。圖50係顯示構成實施例8之片體10之圖案層15之平面圖。另外，圖48中顯示安裝有標籤本體54。實施例8之片體10之構造，係在反射區域形成層12上依序堆疊：第二貯藏體層13、第一貯藏體層14、膜層/接合層207及圖案層15。圖案層15由導電性圖案22與間隔物(基底)21所構成。反射區域形成層12及圖案層15由鋁蒸鍍PET膜而構成。圖案層15係使導電性圖案22與膜層/接合層207相對而設置。另外，膜

層/接合層及間隔物(基底)等，亦係本發明中所稱之貯藏體層。

本實施例中，導電性圖案22係圖25所示之圖案形狀，且係將邊長 $W1=45$ mm之正方形之矩形圖案形狀31a，切成以間隔 $W2=1$ mm而並列4個之尺寸，以圖48~圖50所示之構造，計算安裝於片體10之標籤本體54之對應金屬之通信改善效果。包含試作之標籤本體54及片體10之厚度約為3 mm，而達成薄型化。試作之標籤本體54如圖49所示，係大致長方形狀(長度147 mm，寬度10 mm)，IC52之標籤晶片之阻抗，在950 MHz頻帶中，係作為 $30-j250(\Omega)$ 之UHF頻帶用。標籤本體54在4個矩形圖案形狀31a並列之方向上，使長度方向一致，而重疊配置於由4個矩形圖案形狀31a構成之導電性圖案22之中央部。

表4顯示實施例8之片體10之構成材料之材料常數。表4中顯示：間隔物(基底)21、膜層/接合層207、第一貯藏體層14及第二貯藏體層13之層厚、複數相對介電常數之實數部 ϵ' 、介電損失 $\tan\delta(\epsilon)$ 、複數相對磁導率之實數部 μ' 、磁性損失 $\tan\delta(\mu)$ 及導電率 σ 。

[表4]

各層名稱	厚度(mm)	ϵ'	$\tan\delta(\epsilon)$	μ'	$\tan\delta(\mu)$	導電率 σ
間隔物(基底)	1	3	0.01	1	0	0
膜層/接合層	0.15	3	0.01	1	0	0
第一貯藏體層	0.5	15.1	0.049	4.55	0.24	0.039
第二貯藏體層	1.5	3	0.01	1	0	0

表5顯示使用實施例8之片體10時之標籤本體54之天線特性之評估結果。表5中顯示：950 MHz頻帶之電磁波中之測定反射係數S11、阻抗之實數部Z11之實部、阻抗之虛數部Z11之虛部及絕對增益；及在自由空間使用標籤本體54時之相對比較。在自由空間使用標籤本體54時之相對比較時，顯示對天線元件51之供電、自天線元件51之放射、總數(total)及估計通信距離。此時，表中之「供電」表示自晶片對天線元件之匹配程度，表示數值愈大愈可取得匹配(Matching)。並顯示將自由空間作為1時之比較。「放射」表示取匹配而自晶片供給相同大小之電力至天線元件時之放射電力。此亦顯示將自由空間作為1時之比較。「total」表示不取匹配，而自晶片供給相同大小之電力至天線元件時之放射電力。同樣地顯示將自由空間作為1時之比較。該「total」之比較，係表示天線特性之比較。表5中亦顯示自妨礙通信構件57隔以3.15 mm之間隔而配置標籤本體54時之天線特性，作為比較例。

就估計通信距離之基本估計公式顯示於公式(3)。

[數2]

通信距離[m]=

$$\sqrt{\frac{\text{傳送電力} EIRP[W] \times \text{標籤之天線增益[真值]} \times \text{偏振損失[真值]}}{(4\pi)^2 \times \text{標籤之必要最低電力}[W]}} \times \text{波長}[m]$$

...(3)

標籤之傳送電力一定，不考慮偏振損失，而與標籤之天線增益(真值)之平方根($\sqrt{\quad}$)成正比來估計。此外，天線增益

與動作增益(包含匹配損失及材料損失之增益)相同。

[表 5]

	950 MHz				與自由空間比較			
	S11(dB)	Z11之實部	Z11之虛部	絕對增益(dBi)	供電	放射	total	估計通信距離
自由空間	-11.827	24.309	236.863	2.290	1.000	1.000	1.000	1.000
Gap (3.15 mm)	-0.0750078	32.016	-219.603	7.052	0.018	2.994	0.055	0.234
實施例8	-11.0416	19.2147	258.976	-3.532	0.986	0.262	0.258	0.508

結果如表 5 所示，使用本實施例之片體 10 時之估計通信距離為自由空間之 51%，而自妨礙通信構件 57 設置相當厚度 (3.15 mm) 部分之空間之比較例，約為自由空間之 23%，即使與比較例比較，仍顯示一倍以上之通信距離，因此發現可使用本實施例之片體 10 作為 UHF 頻帶用對應薄型金屬天線體之可能性。

此外，表 6 顯示試作之標籤本體 54 之放射效率。此時可表示成放射效率 $\eta = 10^{(\text{增益} - \text{指向性增益})/10}$ 。指向性增益係不含金屬等損失之增益。增益(此處指的是通常僅寫成 Gain 者)可說是包含損失之「亦即真正增益」。此外，天線之放射電阻設為 R_{rad} ，損失電阻設為 R_{loss} 時，係放射效率 $\eta = R_{\text{rad}} / (R_{\text{rad}} + R_{\text{loss}})$ 。 R_{rad} 相當於無損失天線之輸入阻抗之電阻。實施例 8 中使用之標籤本體 54，其指向性增益為 7.44 dBi，增益(絕對增益)為 -3.53 dBi，且放射效率約為

8%。

[表 6]

指向性增益 (dBi)	絕對增益 (dBi)	放射效率
7.440	-3.532	7.99%

【圖式簡單說明】

圖 1 係本發明一種實施形態之片體 10 之剖面圖。

圖 2 係放大第一貯藏體層 14 之內部構造而顯示之剖面圖。

圖 3 係顯示構成本發明一種實施形態之片體 10 之圖案層 15 之前視圖。

圖 4 係放大圖 3 所示之實施形態中之圖案層 15 之一部分之前視圖。

圖 5 係放大圖 3 所示之實施形態中之圖案層 15 之一部分之前視圖。

圖 6 係顯示模擬計算因導電性圖案 22 切斷之影響而變化之共振頻率之結果圖。

圖 7 係第一片體 10A 之前視圖。

圖 8 係分解包含片體 10 之標籤 50 而顯示之立體圖。

圖 9 係顯示將標籤 50 貼合於妨礙通信構件 57 之狀態圖。

圖 10 係顯示天線元件 51 與圖案層 15 之電磁耦合及圖案層 15 與電波反射層 12 之電磁耦合之剖面圖。

圖 11 係模式顯示入射於片體 10 之電磁波(稱為行波)及被片體 10 反射之電磁波(稱為反射波)之圖。

圖 12 係說明電磁波之反射之圖。

圖 13 係放大圖 11 所示之片體 10 之一部分而模式顯示之圖。

圖 14 係放大標籤 50 之一部分而顯示之立體圖。

圖 15 係就以圖 14 所示之虛擬線 48 表示之區域顯示模擬之電磁場強度之圖。

圖 16 係放大構成圖 1 所示之實施形態中之片體 10 之其他實施形態之圖案層 15 之一部分之立體圖。

圖 17 係放大構成圖 1 所示之實施形態中之片體 10 之其他實施形態之圖案層 15 之一部分之立體圖。

圖 18 係放大構成圖 1 所示之實施形態中之片體 10 之其他實施形態之圖案層 15 之一部分之立體圖。

圖 19 係構成圖 1 所示之實施形態中之片體 10 之其他實施形態之圖案層 15 之前視圖。

圖 20 係放大圖 19 之圖案層 15 之一部分而顯示之立體圖。

圖 21 係顯示構成圖 1 所示之實施形態中之片體 10 之其他實施形態之雙峰特性之圖案層 15 之前視圖。

圖 22 係圖 21 所示之實施形態中之圖案層 15 之一部分放大之立體圖。

圖 23 係顯示構成圖 1 所示之實施形態中之片體 10 之其他實施形態之雙峰特性之圖案層 15 之前視圖。

圖 24 係圖 23 所示之實施形態中之圖案層 15 之一部分放大之立體圖。

圖 25 係構成圖 1 所示之實施形態中之片體 10 之其他實施

形態之圖案層 15 之前視圖。

圖 26 係放大圖 25 所示之圖案層 15 之一部分而顯示之立體圖。

圖 27 係顯示構成圖 1 所示之實施形態中之片體 10 之其他實施形態之圖案層 15 之前視圖。

圖 28 係顯示構成圖 1 所示之實施形態中之片體 10 之其他實施形態之圖案層 15 之前視圖。

圖 29 係放大圖 28 所示之圖案層 15 之一部分而顯示之立體圖。

圖 30 係構成圖 1 所示之實施形態中之片體 10 之另外實施形態之圖案層 15 之前視圖。

圖 31 係構成圖 1 所示之實施形態中之片體 10 之另外實施形態之圖案層 15 之前視圖。

圖 32 係顯示其他形態之矩形圖案 71 之前視圖。

圖 33 係顯示本發明另外實施形態之放射形圖案形狀 70 之前視圖。

圖 34 係構成圖 1 所示之實施形態中之片體 10 之另外實施形態之圖案層 15 之前視圖。

圖 35 係本發明之另外實施形態，而顯示與圖 34 之圖案層 15 在尺寸上構造不同之其他圖案層 15 之前視圖。

圖 36 係顯示可用作本發明另外實施形態之其他圖案層 15 之前視圖。

圖 37 係顯示可用作本發明另外實施形態之其他圖案層 15 之前視圖。

圖 38 係顯示可用作本發明另外實施形態之其他圖案層 15 之前視圖。

圖 39 係顯示可用作本發明另外實施形態之其他圖案層 15 之前視圖。

圖 40 係放大構成圖 1 所示之實施形態中之片體 10 之其他實施形態之圖案層 15 之一部分而顯示之前視圖。

圖 41 係放大圖 40 之一部分而顯示之圖案層 15 之前視圖。

圖 42 係顯示本發明另外實施形態之片體 10a 之剖面圖。

圖 43 係顯示本發明另外實施形態之片體 10b 之剖面圖。

圖 44 係顯示本發明另外實施形態之片體 10c 之剖面圖。

圖 45 係模式顯示通信試驗之狀態圖。

圖 46 係模式顯示通信試驗之狀態圖。

圖 47 係顯示模擬計算實施例 7 之片體 10 之反射損失之結果圖。

圖 48 係顯示實施例 8 之片體 10 之剖面圖。

圖 49 係顯示安裝於實施例 8 之片體 10 上之標籤本體 54 之平面圖。

圖 50 係顯示構成實施例 8 之片體 10 之圖案層 15 之平面圖。

圖 51 係簡化先前技術之標籤 1 而顯示之剖面圖。

圖 52 係簡化其他先前技術之標籤 1A 而顯示之剖面圖。

【主要元件符號說明】

10 片體

11 貼合層

200723596

12	反射區域形成層
13	第二貯藏體層
14	第一貯藏體層
15	圖案層
22	導電性圖案
50	標籤
51	天線元件

五、中文發明摘要：

本發明提供一種可在妨礙通信之構件近旁，適當地進行無線通信之通信改善用片體與包含其之天線裝置及電子資訊傳達裝置。本發明之形成於圖案層15之導電性圖案22起作用作為天線，於特定頻率之電磁波到來時顯現共振現象，而在片體10中導入特定頻率之電磁波。由於包含圖案層15之片體10雖然小型薄型，卻可調整來自反射區域之反射波相位，因此可藉由來自此處之反射波與到來之電磁波之干擾，而在天線元件近旁設定高電場強度之區域。藉由將該片體10設於天線元件51與妨礙通信構件57之間，可在導電性圖案22之周圍產生電磁場，電磁能自導電性圖案供給至天線元件51，增加天線元件51之接收電力，可適當進行無線通信。

六、英文發明摘要：

十、申請專利範圍：

1. 一種通信改善用片體，其特徵為：包含圖案層，其係在妨礙通信構件之近旁使用天線元件進行無線通信時，設於天線元件與妨礙通信構件之間，並且形成有導電性圖案。
2. 如請求項1之通信改善用片體，其中包含貯藏體層，其係包含非導電性之電介質層及/或磁性體層，並且收集用於無線通信之電磁波能量。
3. 如請求項2之通信改善用片體，其中進一步包含反射區域形成層，其係在與圖案層之間夾著貯藏體層，自圖案層隔以間隔而設於與天線元件相反側，將用於無線通信之電磁波之波長設為 λ 時，在自圖案層起電性長度為 $((2n-1)/4)\lambda$ (n 為正整數)之位置附近，形成反射用於無線通信之電磁波之反射區域。
4. 如請求項1至3中任一項之通信改善用片體，其中圖案層係形成彼此電性絕緣之複數導電性圖案。
5. 如請求項4之通信改善用片體，其中圖案層係形成尺寸及形狀中之至少任一者不同之複數種導電性圖案。
6. 如請求項1至5中任一項之通信改善用片體，其中圖案層係形成涵蓋片體之寬廣範圍而連續延伸之導電性圖案。
7. 如請求項1至6中任一項之通信改善用片體，其中導電性圖案具有至少1個角部係曲線狀之大致多角形之外輪廓形狀。
8. 如請求項7之通信改善用片體，其中圖案層係形成複數

導電性圖案；

組合角部之曲率半徑不同之導電性圖案而形成。

9. 如請求項1至8中任一項之通信改善用片體，其中圖案層係形成複數導電性圖案；

鄰接之2個導電性圖案之間隔依位置而不同。

10. 如請求項1至9中任一項之通信改善用片體，其中用於無線通信之電磁波頻率包含於300 MHz以上300 GHz以下之範圍。

11. 如請求項10之通信改善用片體，其總厚度為50 mm以下。

12. 如請求項10之通信改善用片體，其中用於無線通信之電磁波頻率包含於860 MHz頻帶以上1,000 MHz頻帶以下之任一頻帶，且總厚度為15 mm以下。

13. 如請求項10之通信改善用片體，其中用於無線通信之電磁波頻率包含於2.4 GHz頻帶；

總厚度為8 mm以下。

14. 如請求項1至13中任一項之通信改善用片體，其中貯藏體層係包含對有機聚合物100重量份，作為磁性材料，以1重量份以上1500重量份以下之添加量包含選自鐵氧體、鐵合金及鐵粒子之群中之1個或複數材料之材料。

15. 如請求項1至14中任一項之通信改善用片體，其被賦予難燃性。

16. 如請求項1至15中任一項之通信改善用片體，其中至少一方之表面部具有黏合性或接合性。

200723596

17. 一種天線裝置，其特徵為包含：

天線元件，其係具有配合用於無線通信之頻率之共振
頻率；及

如請求項1至16中任一項之通信改善用片體。

18. 一種電子資訊傳達裝置，其特徵為：包含如請求項17之
天線裝置。

200723596

十一、圖式：

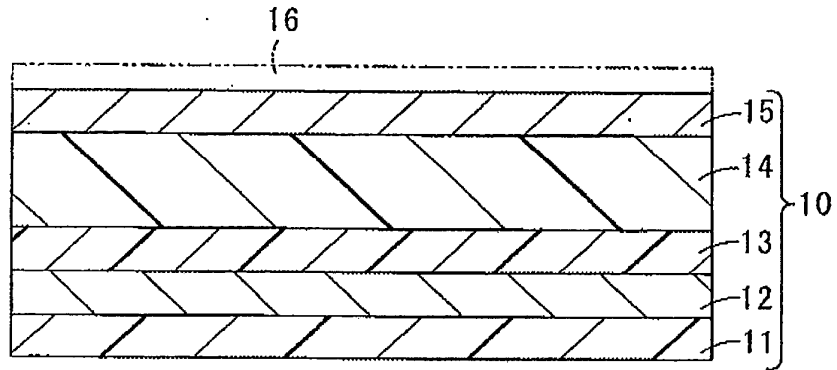


圖 1

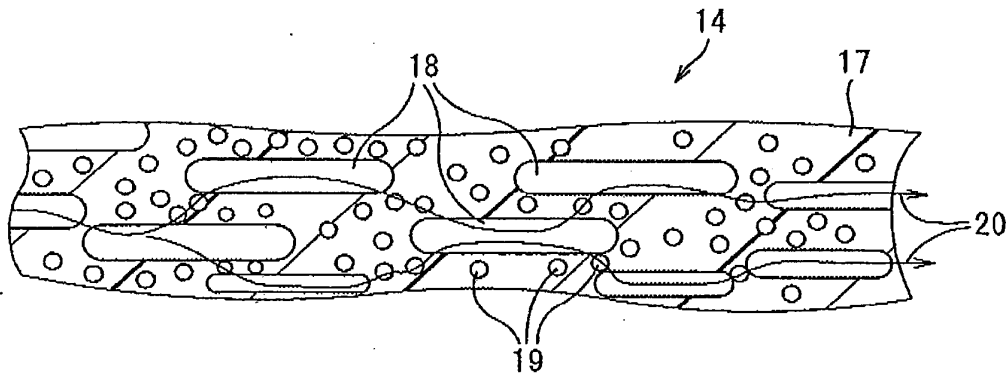


圖 2

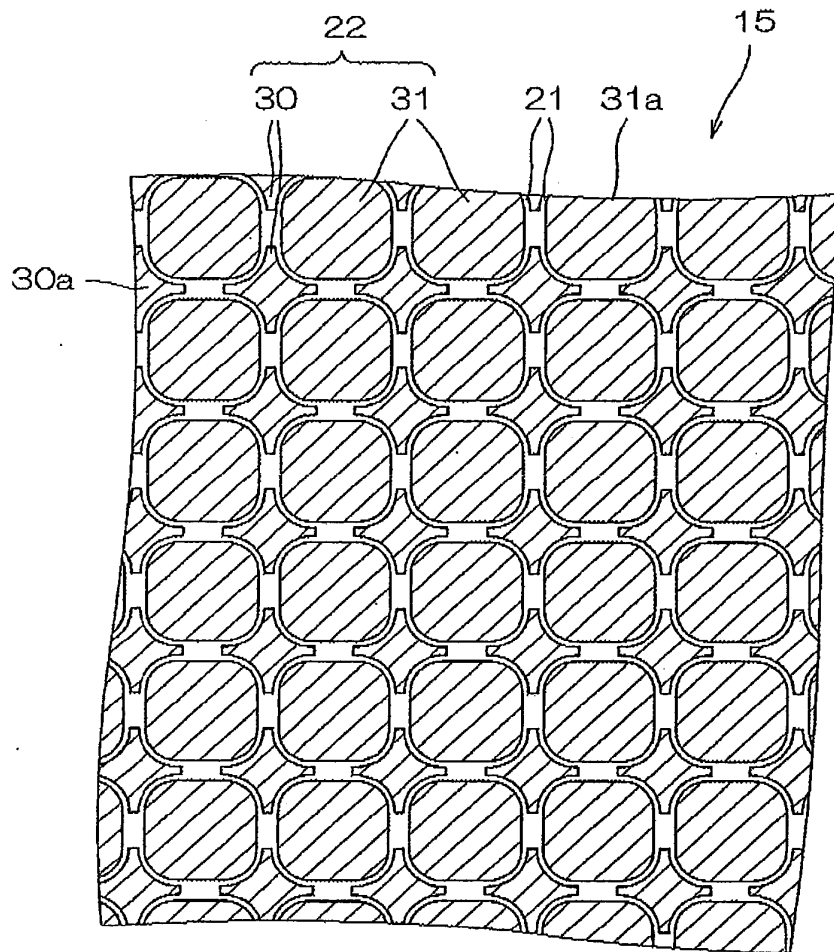


圖 3

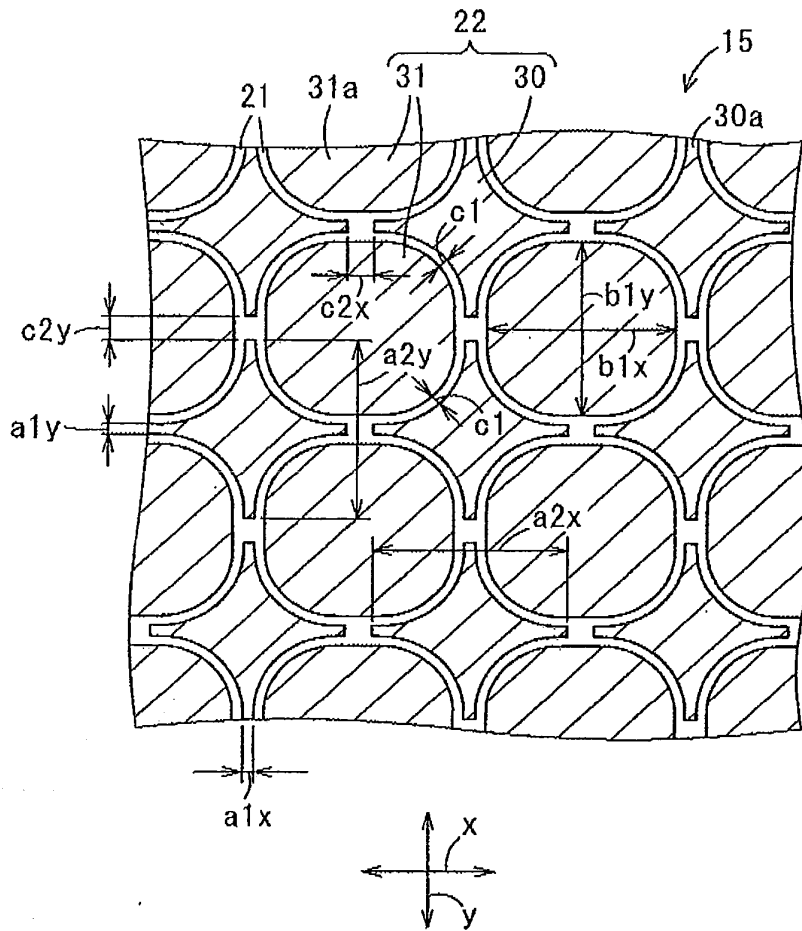


圖 4

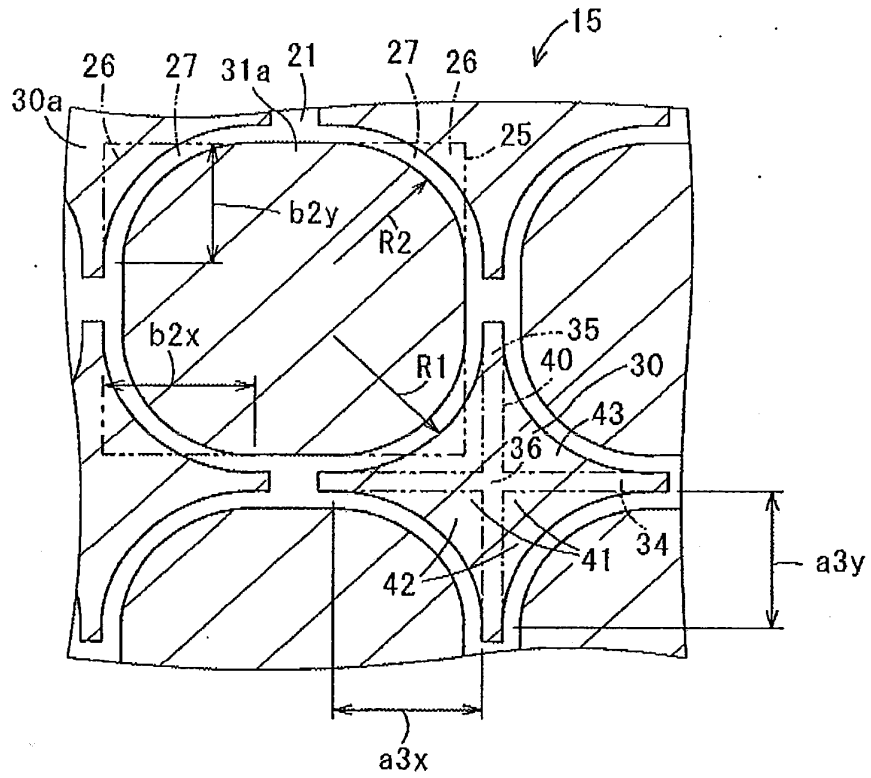


圖 5

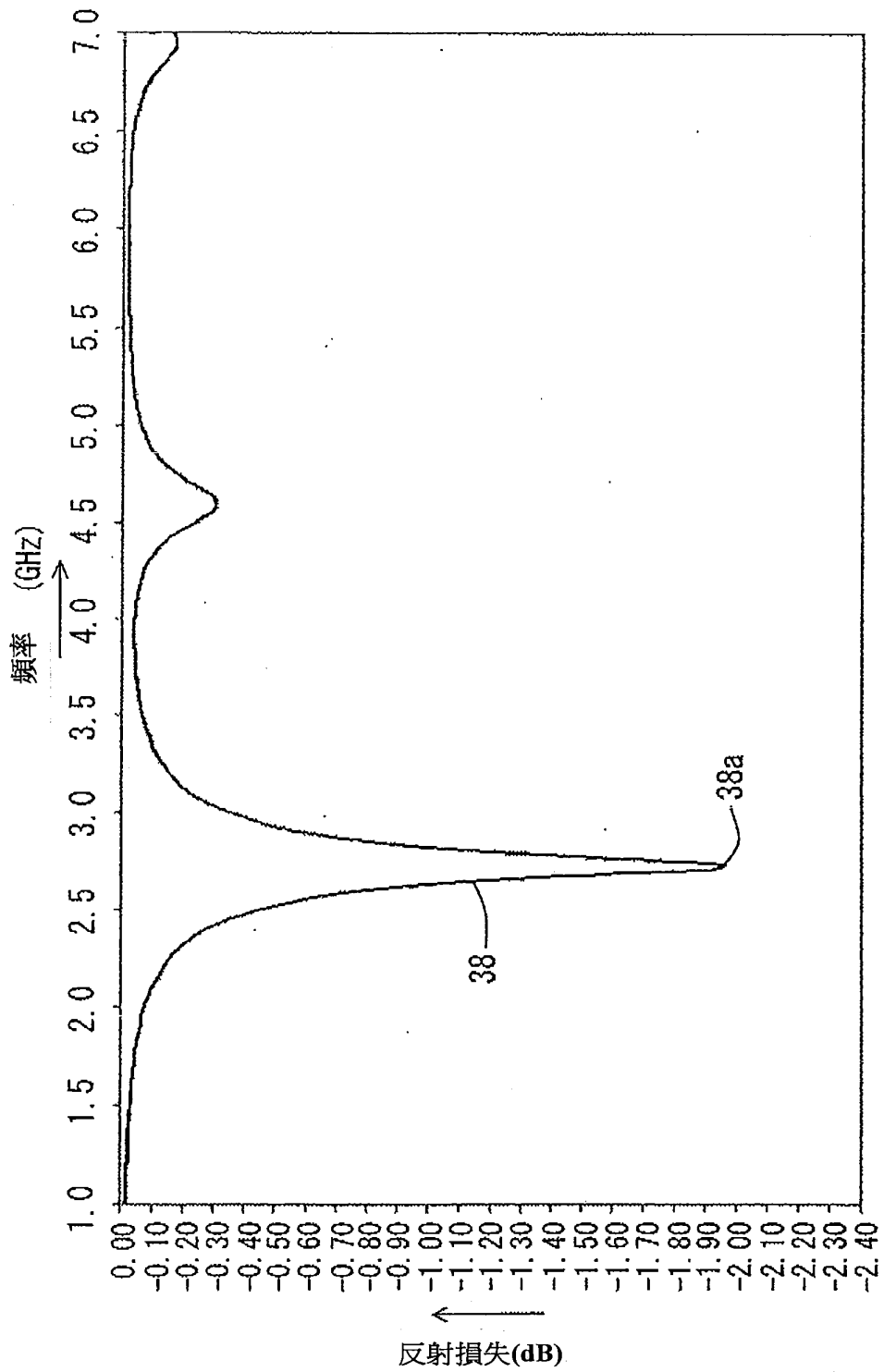


圖 6

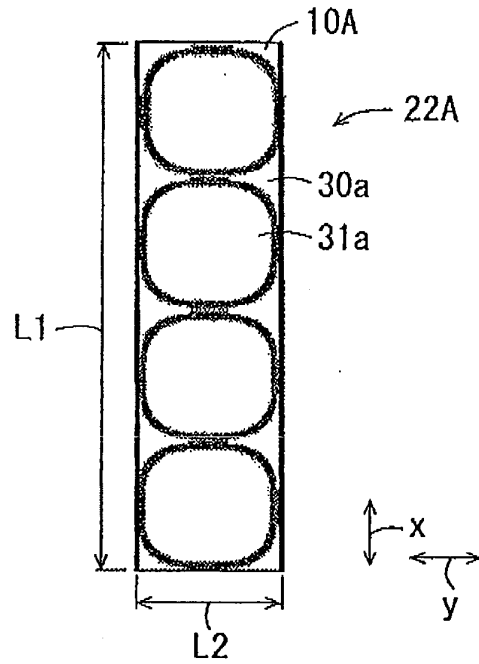


圖 7

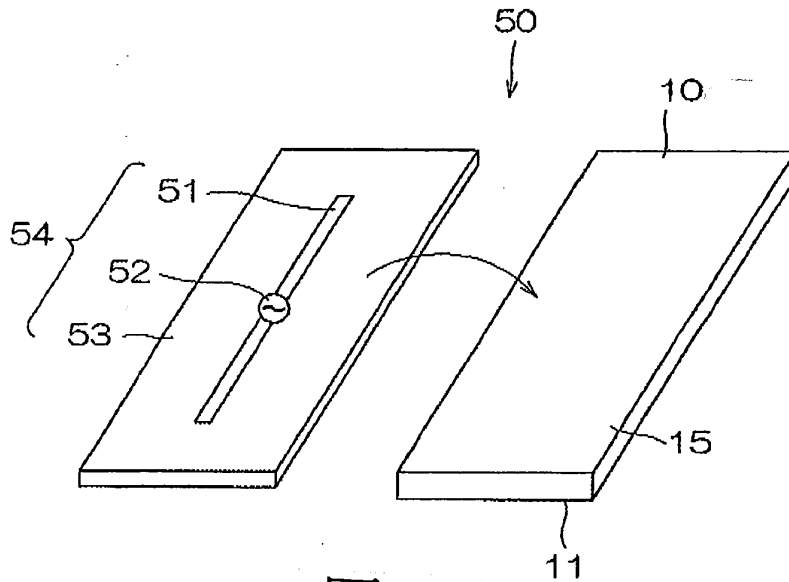


圖 8

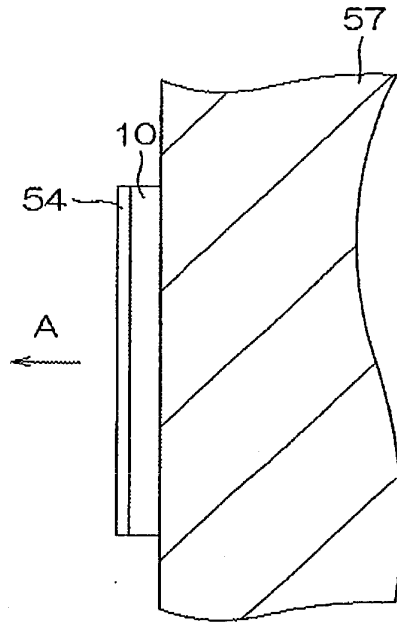


圖 9

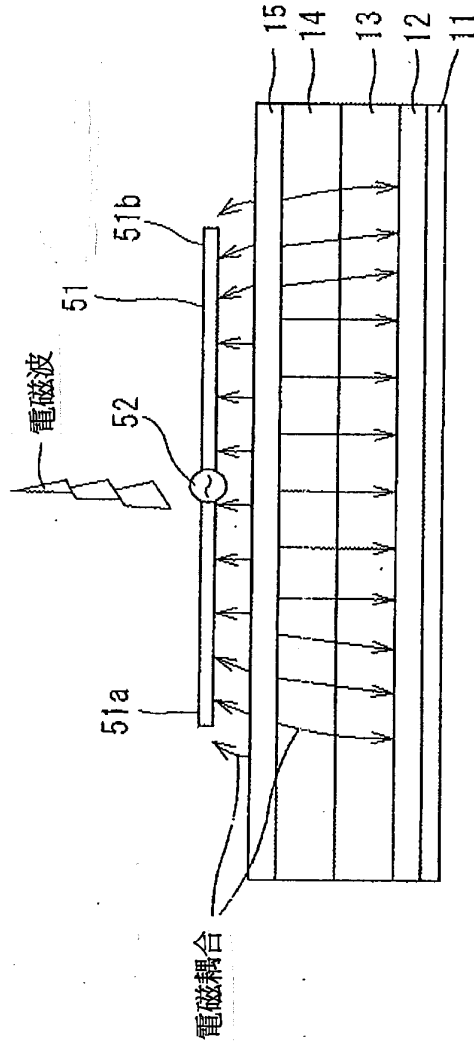


圖 10

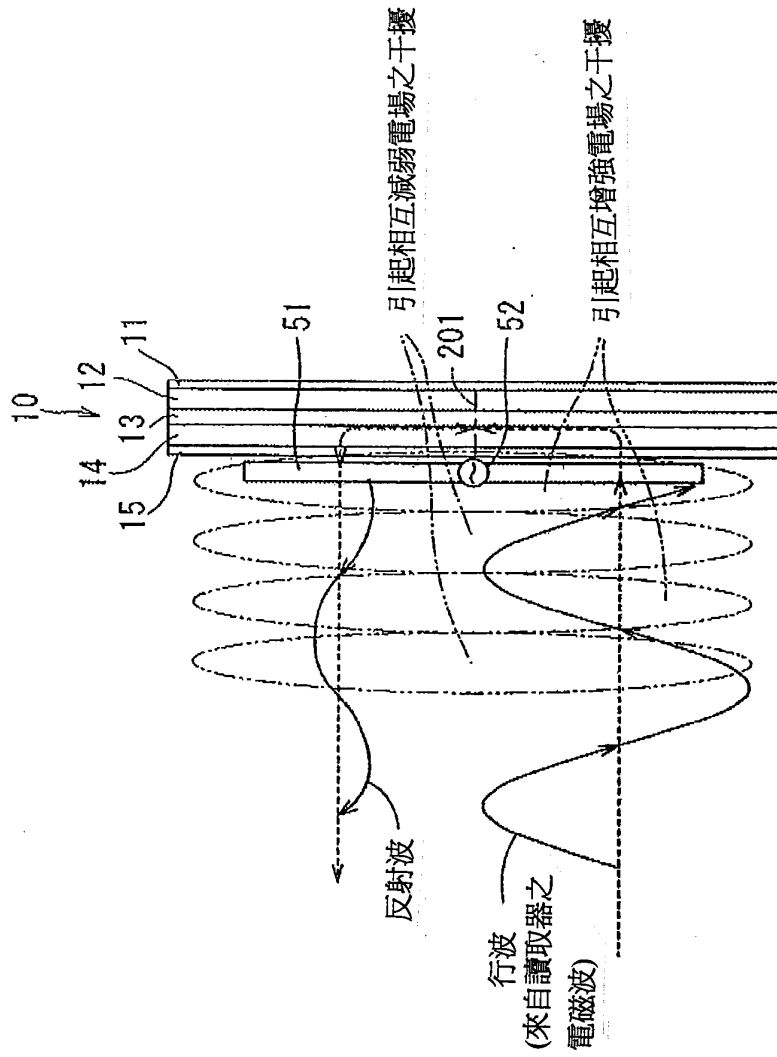


圖 11

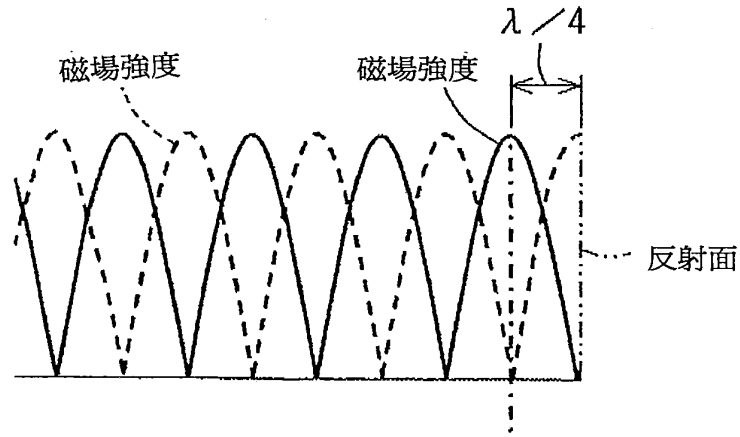


圖 12

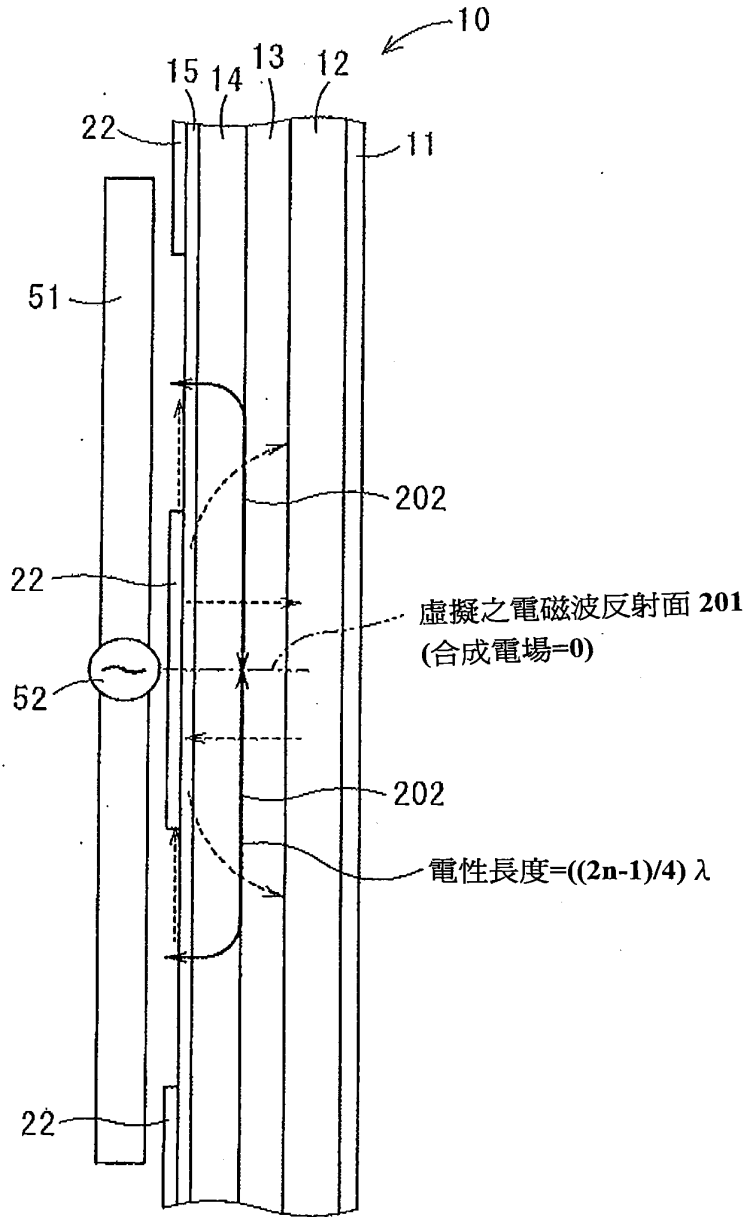


圖 13

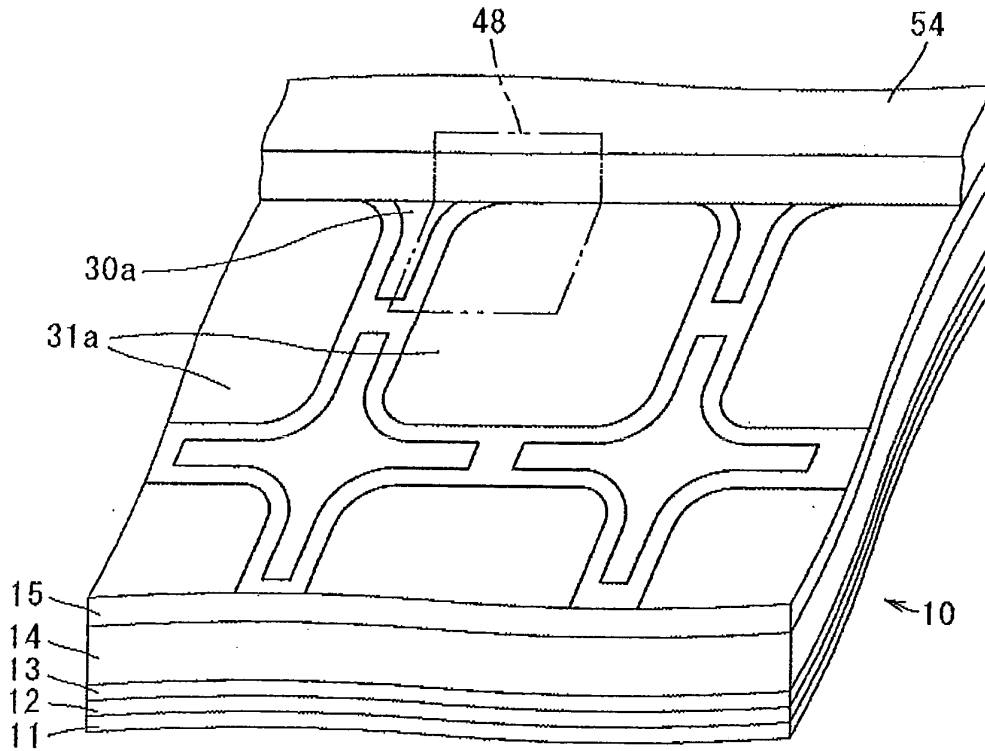


圖 14

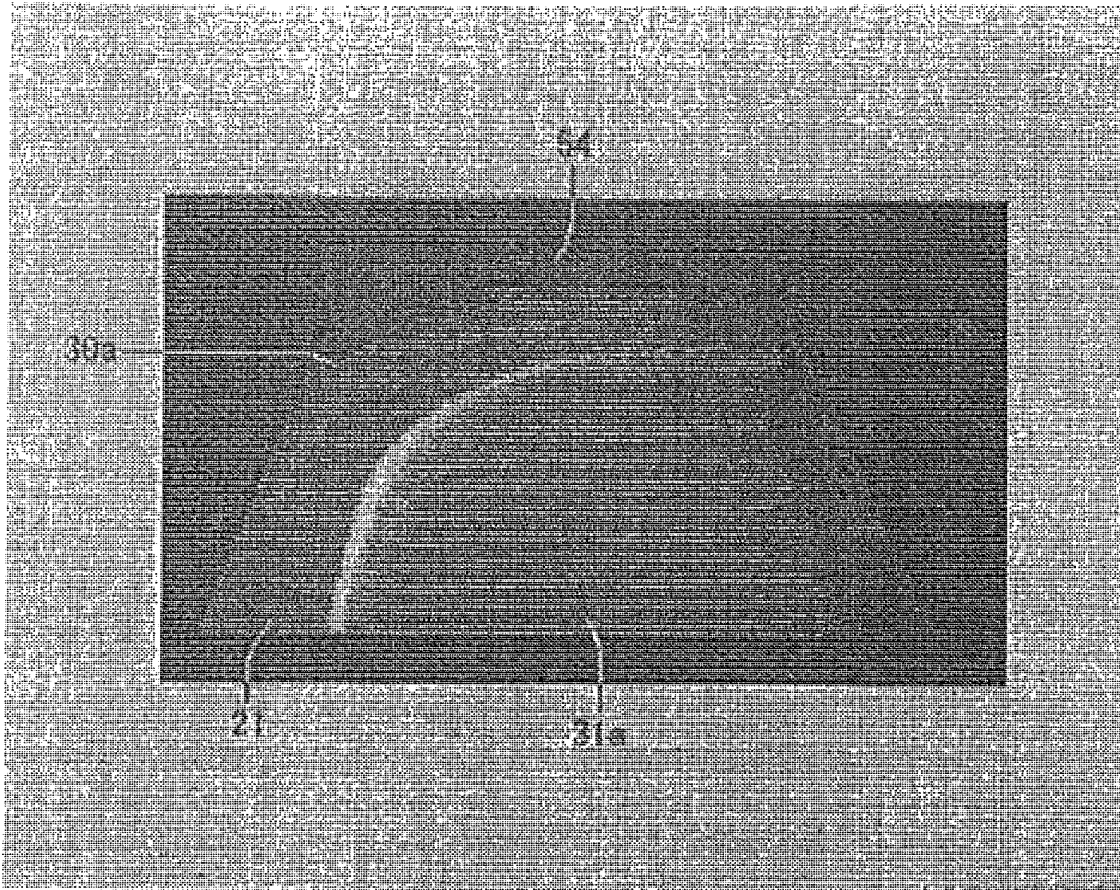


圖 15

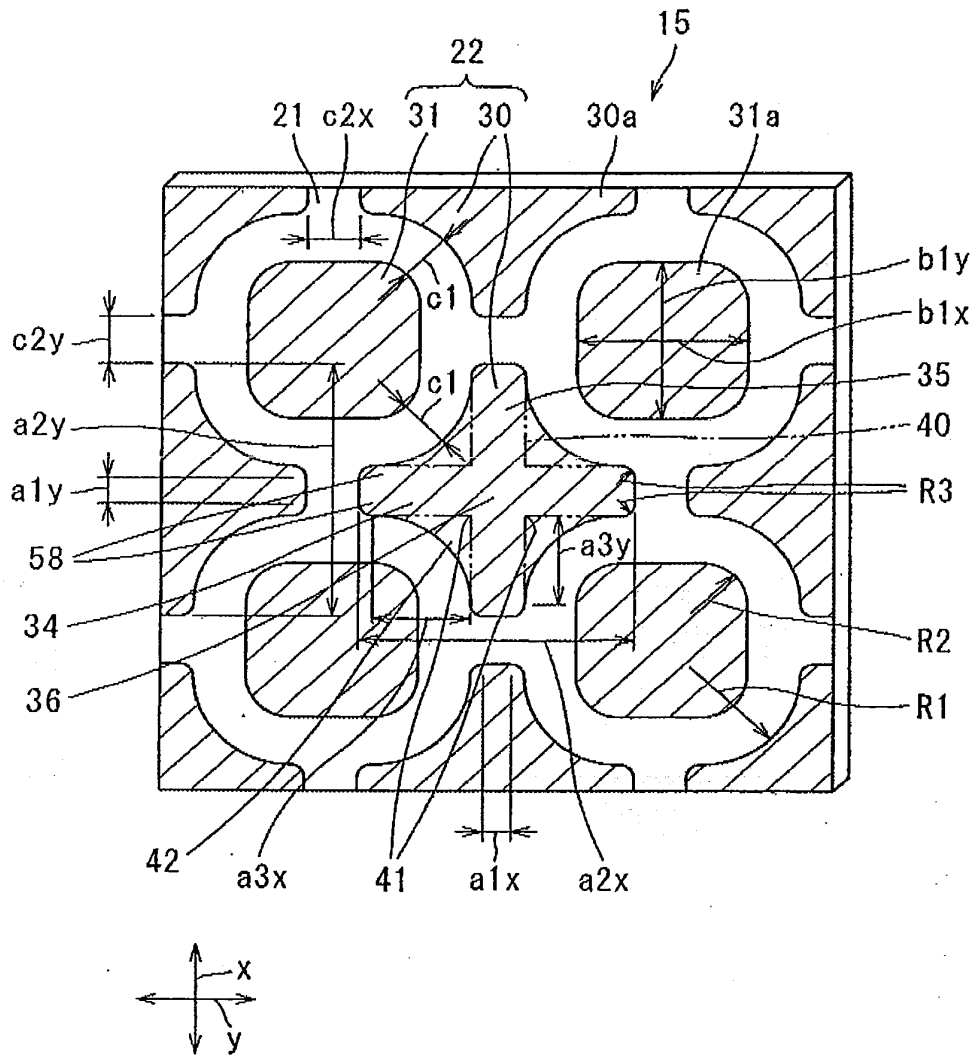


圖 16

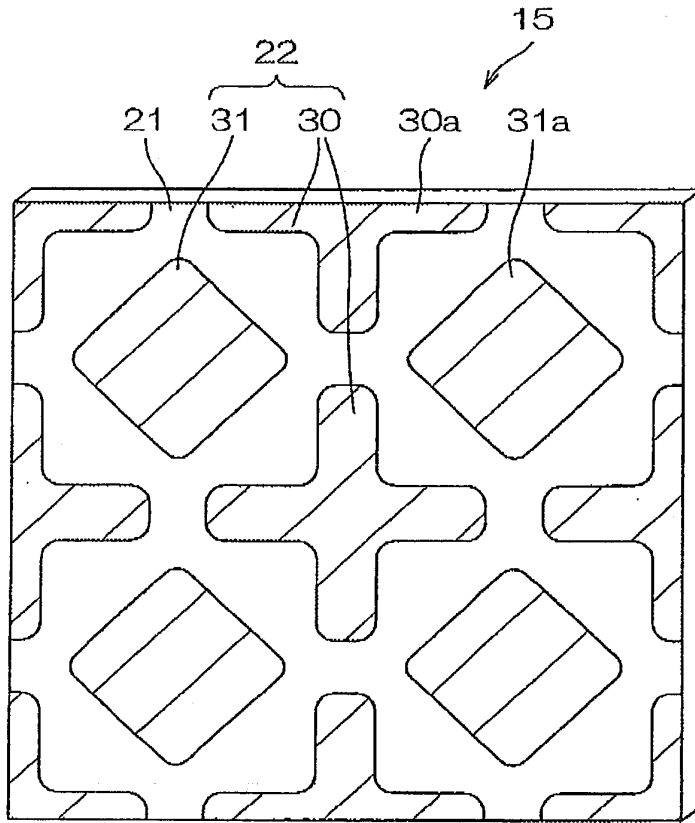


圖 18

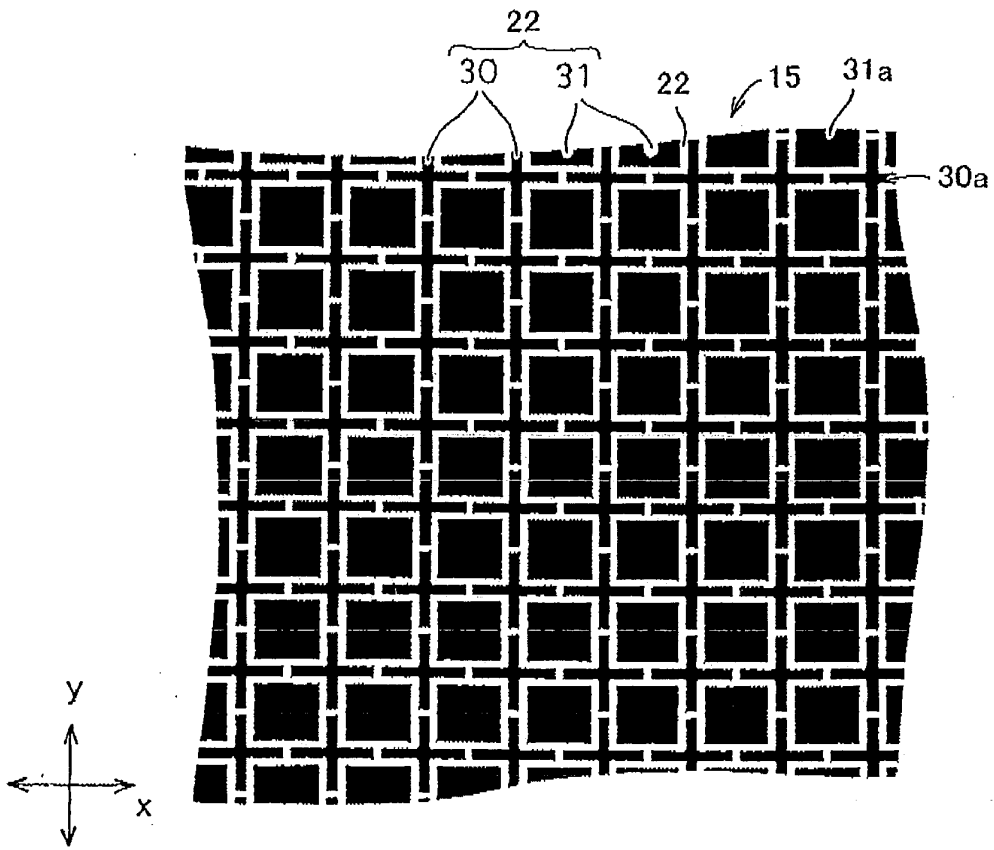


圖 19

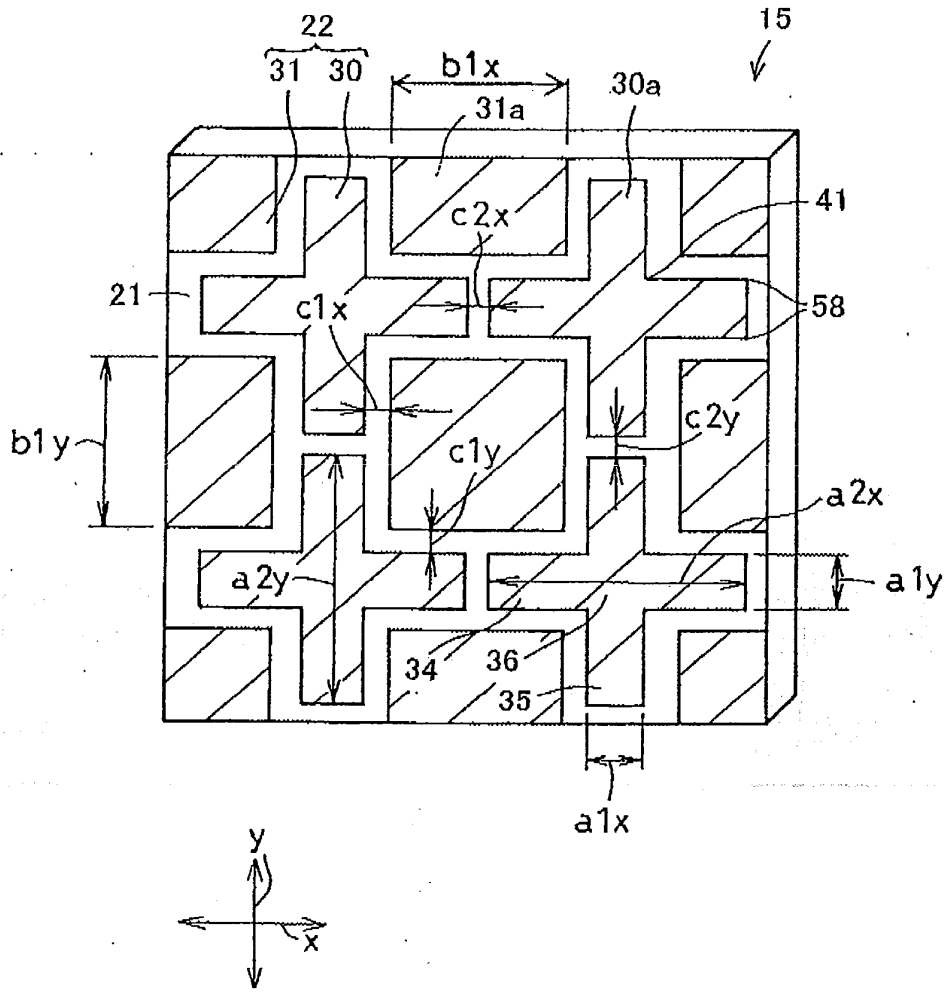


圖 20

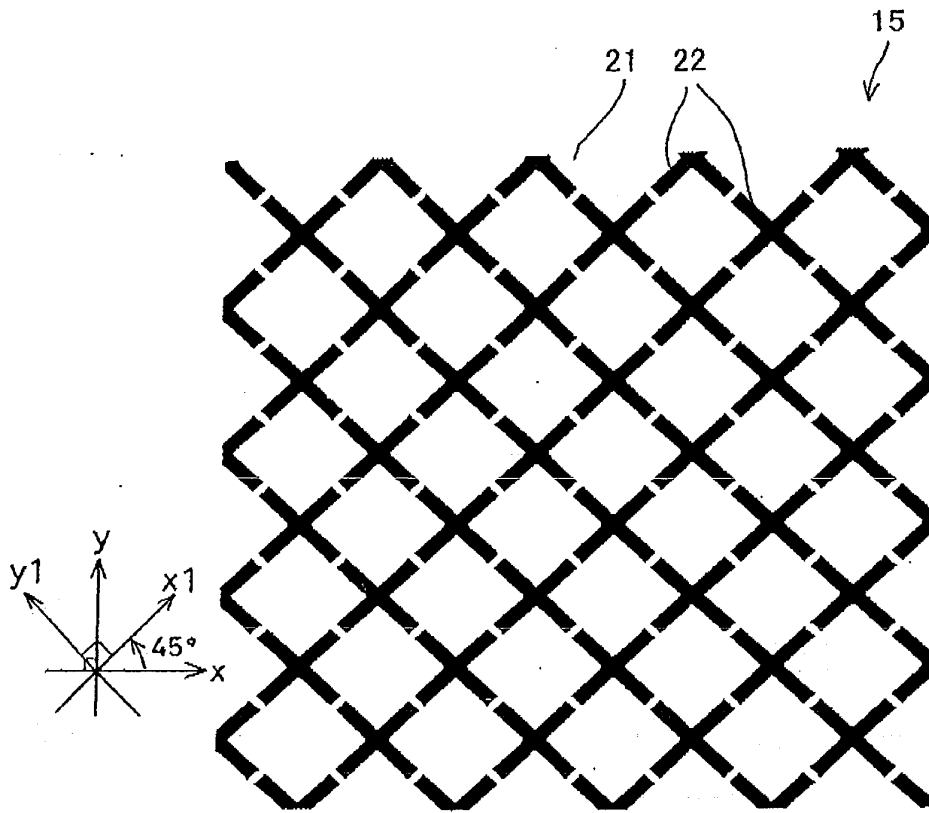


圖 21

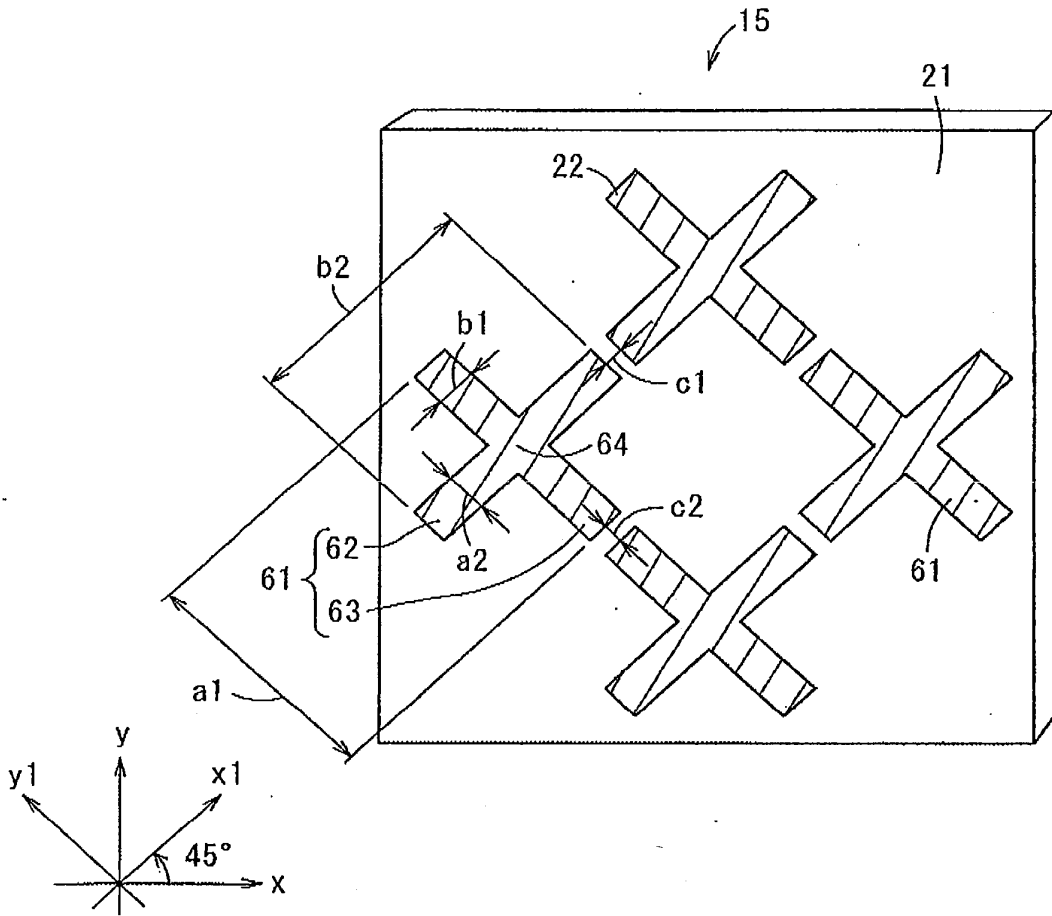


圖 22

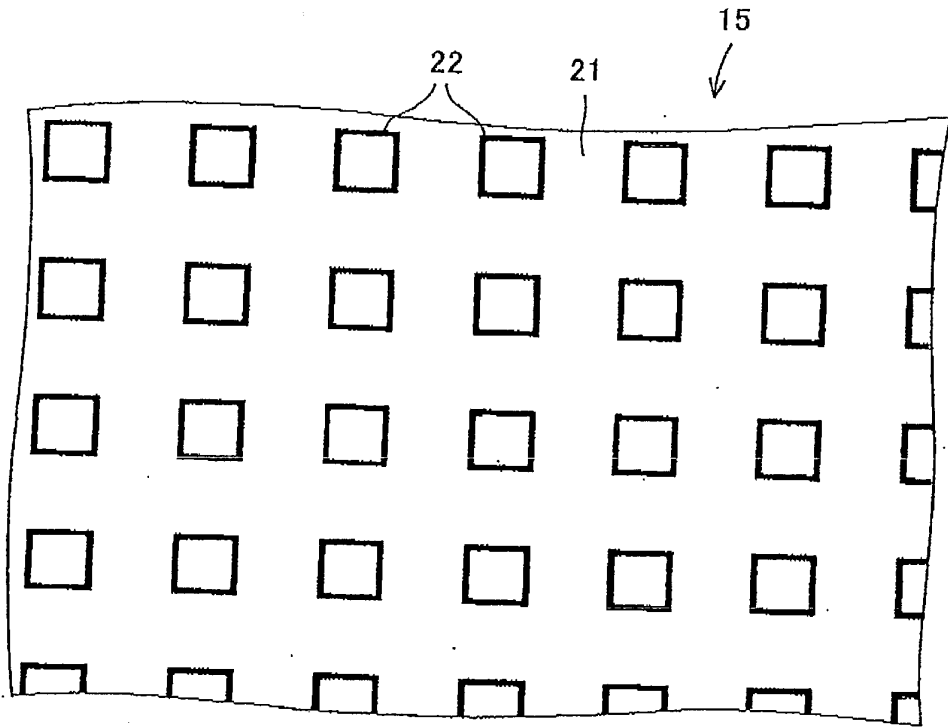


圖 23

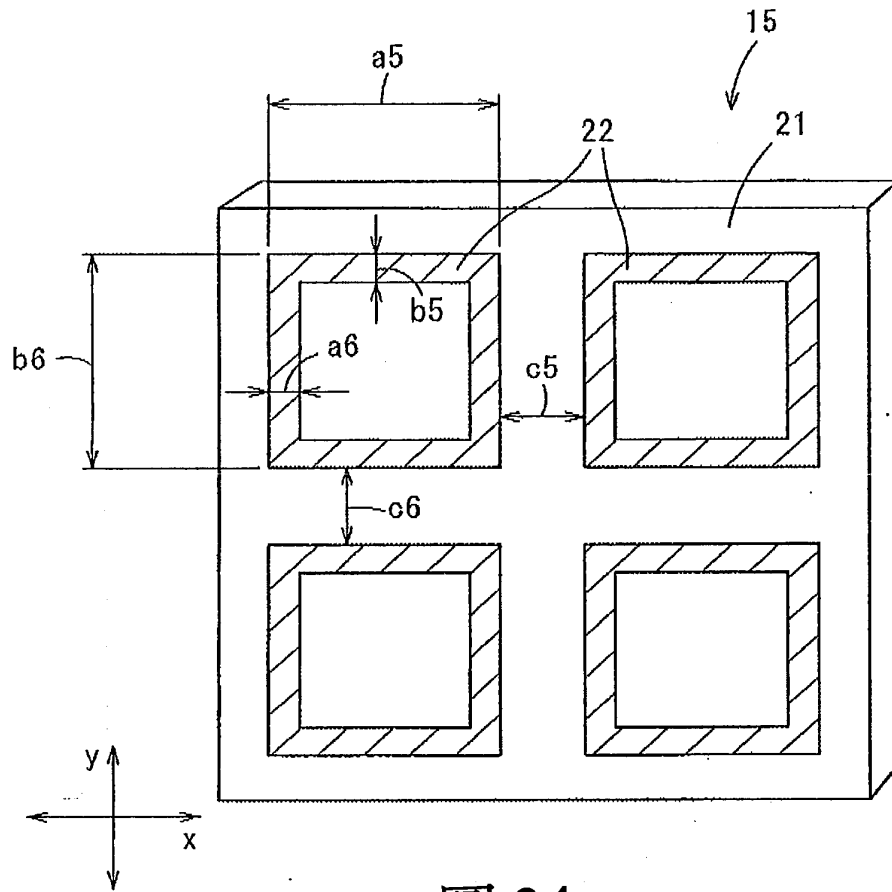


圖 24

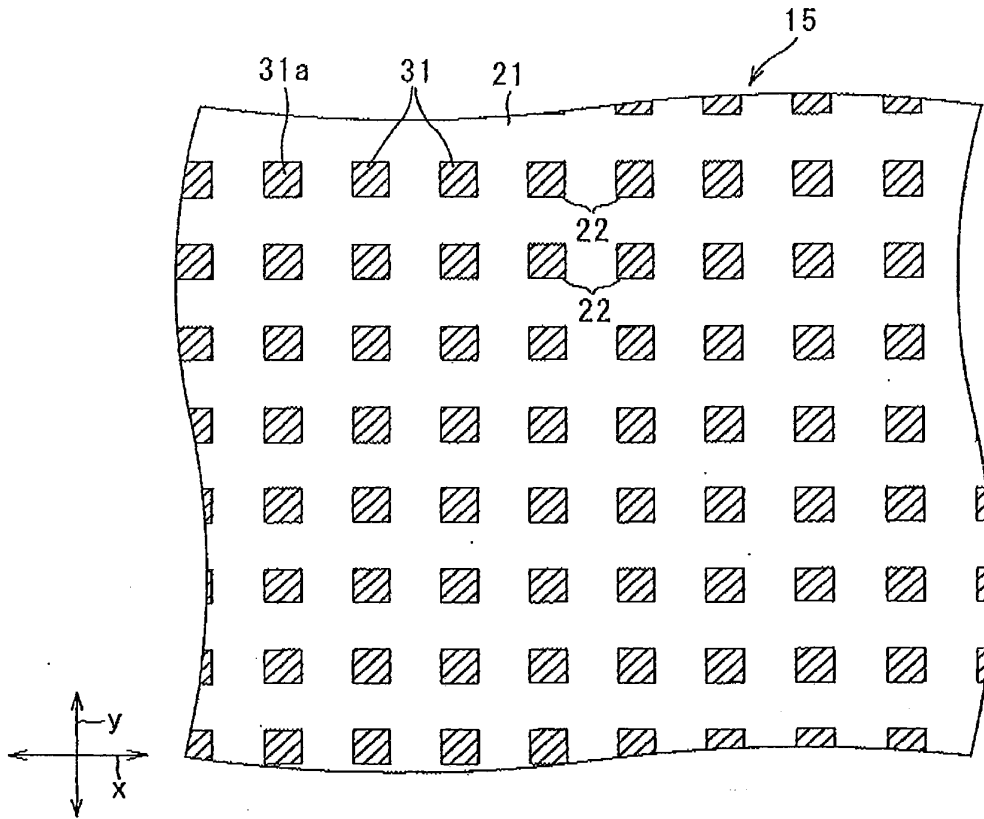


圖 25

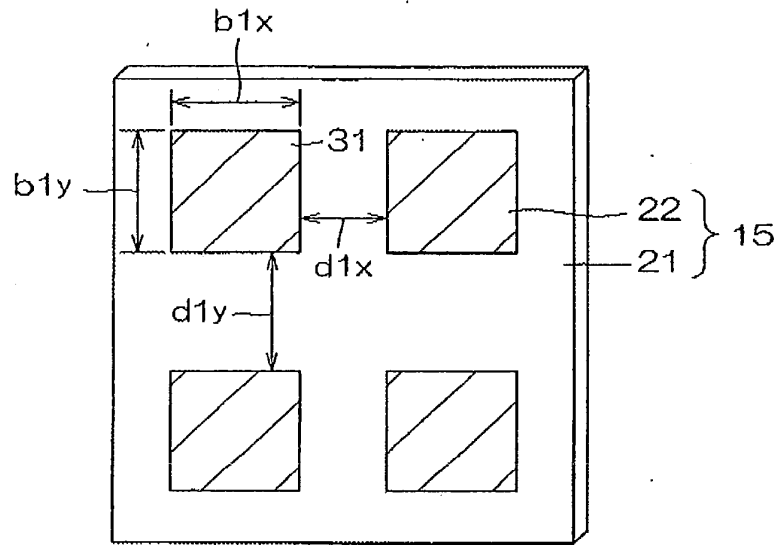


圖 26

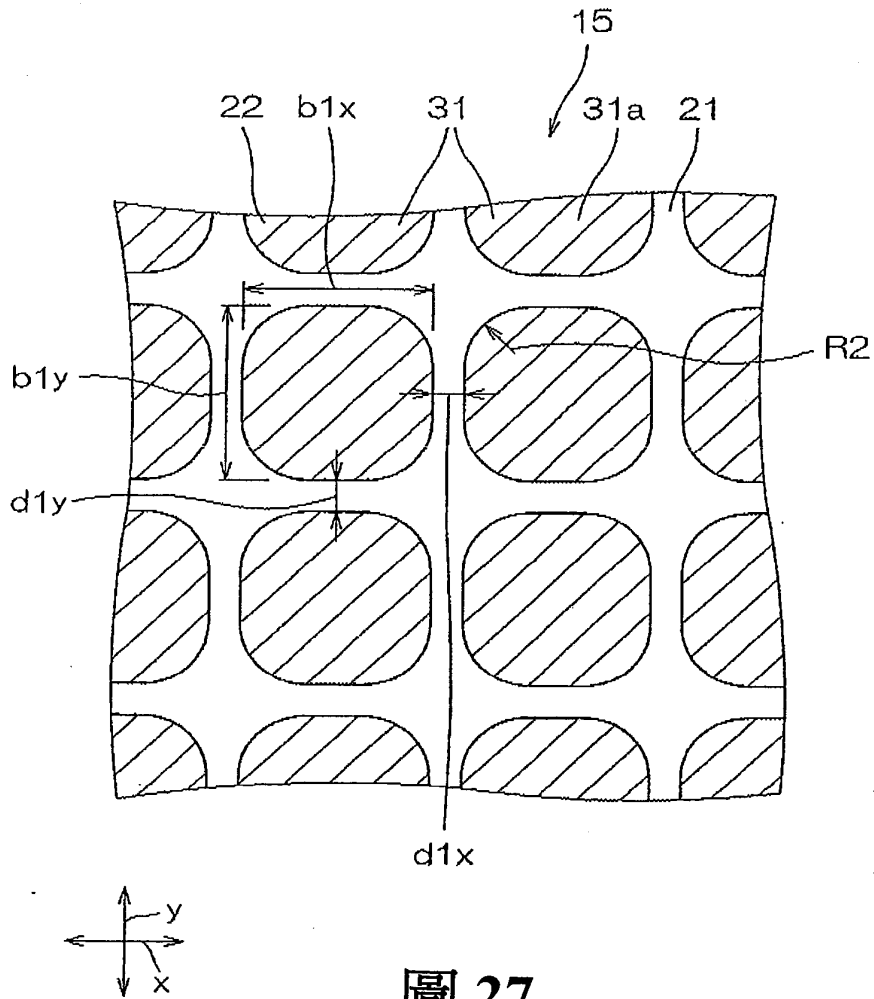


圖 27

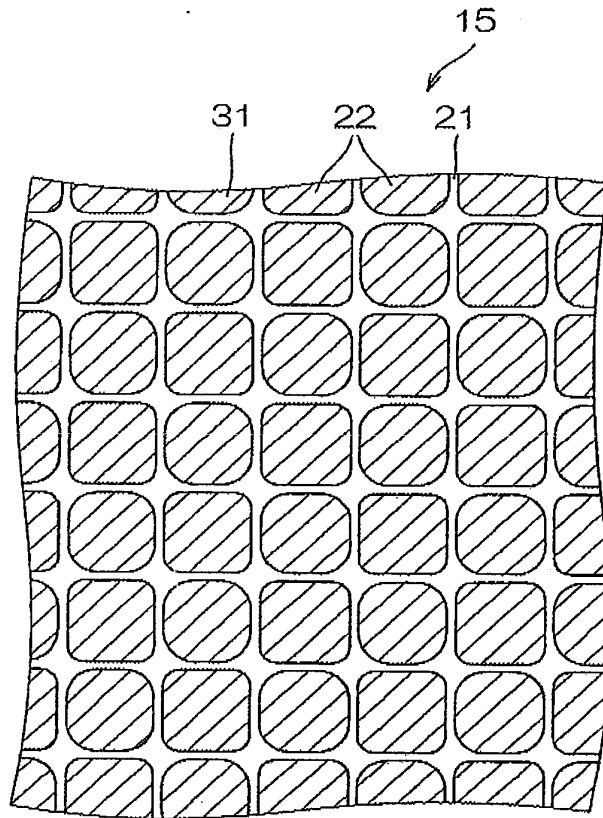


圖 28

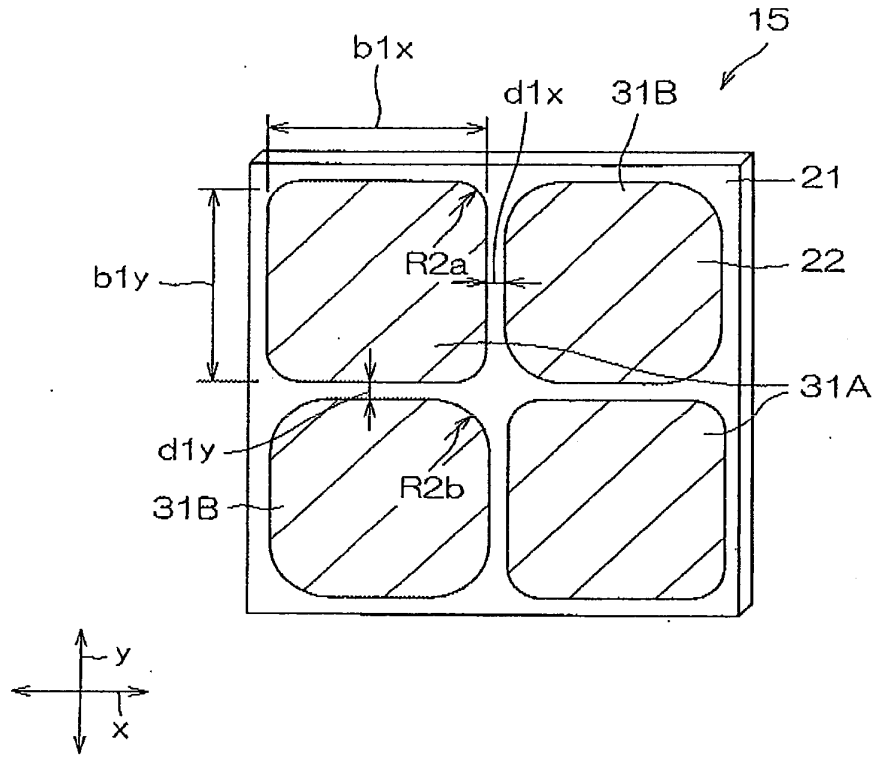


圖 29

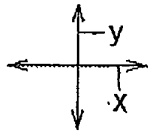
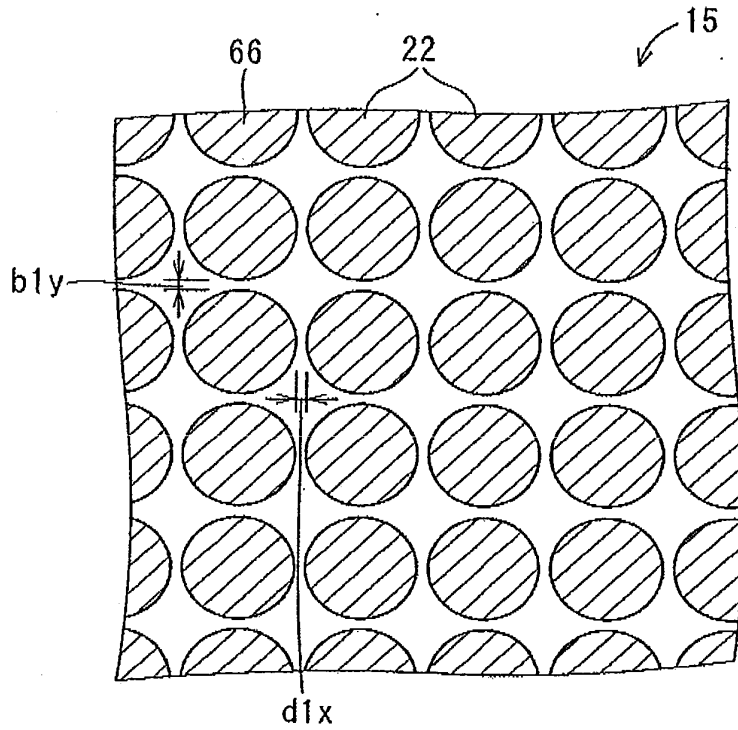


圖 30

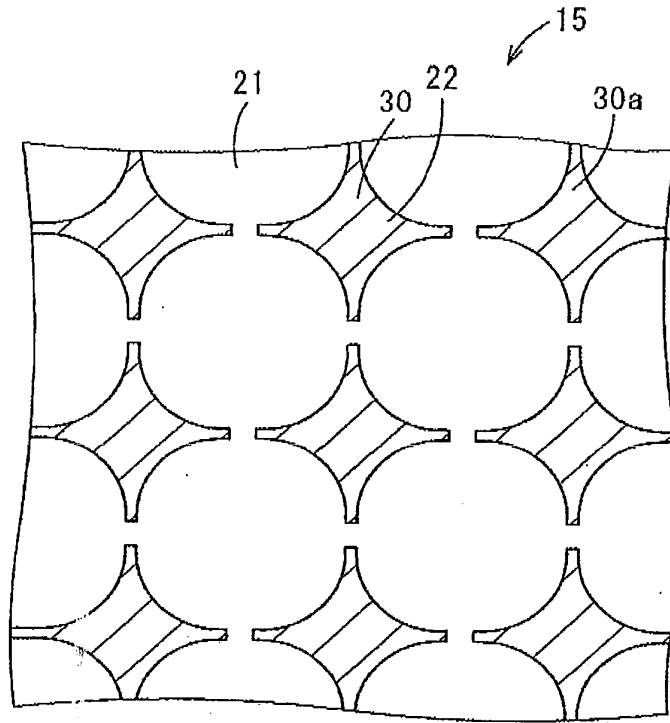


圖 31

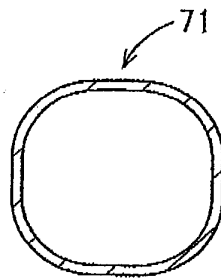


圖 32

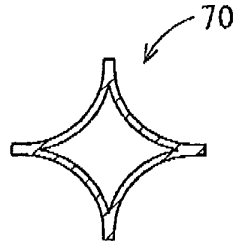


圖 33

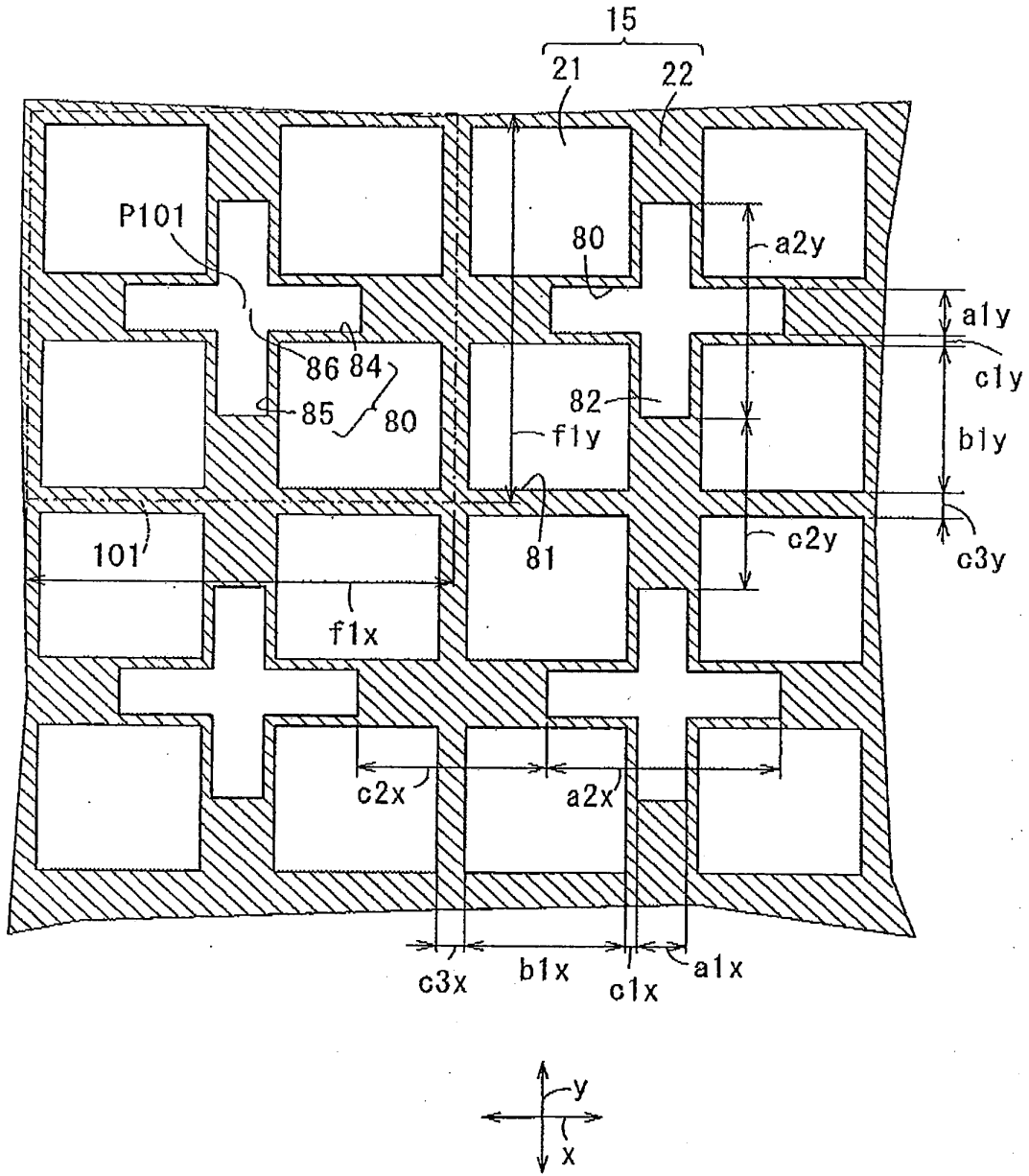


圖 34

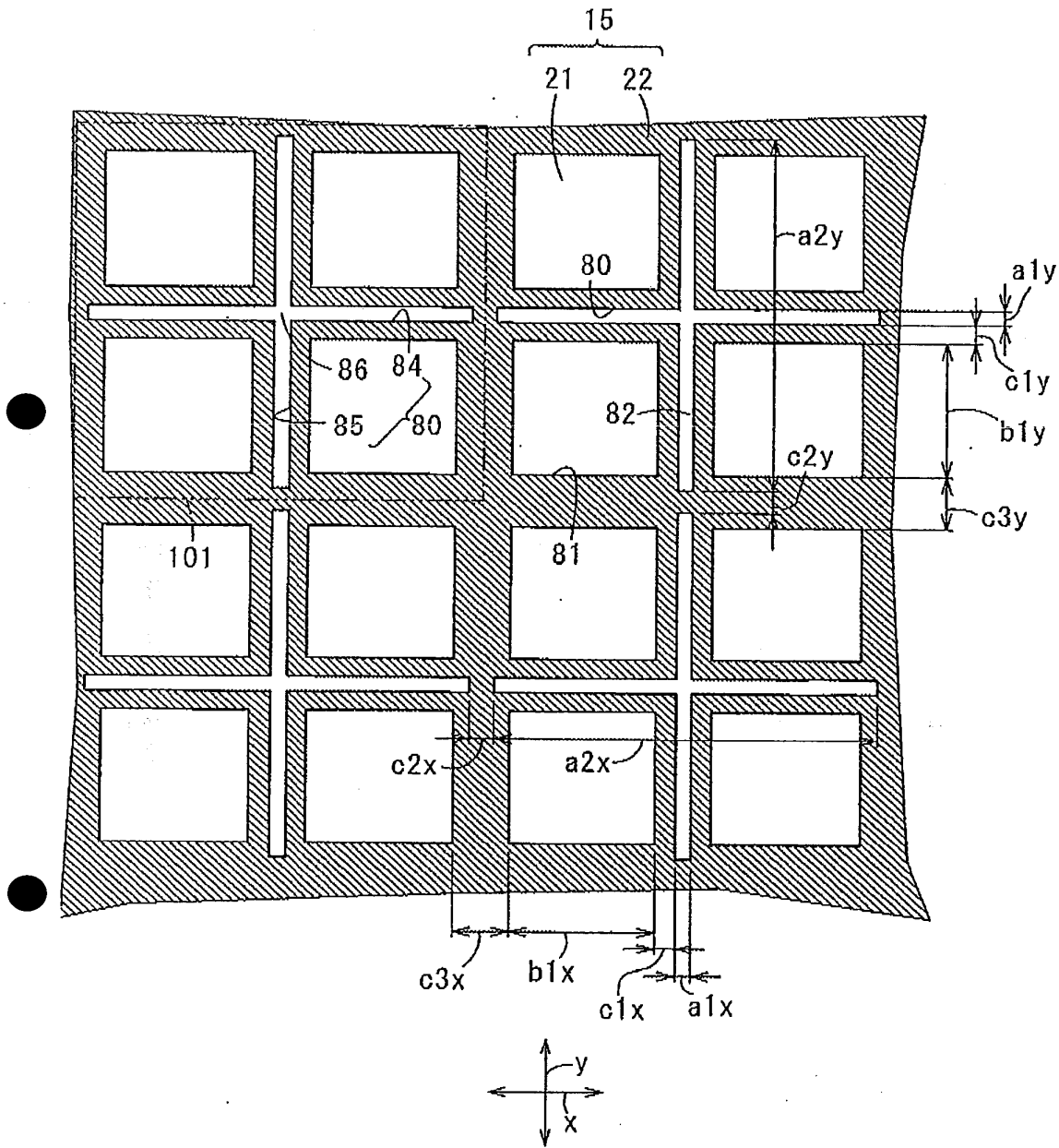


圖 35

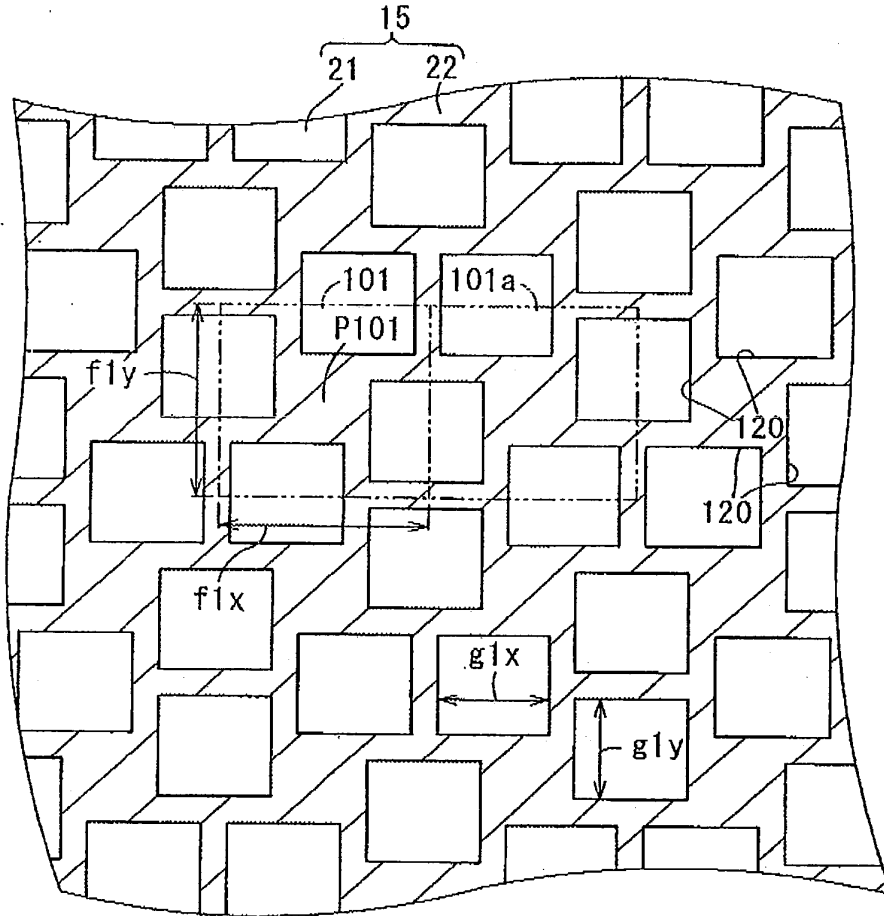


圖 36

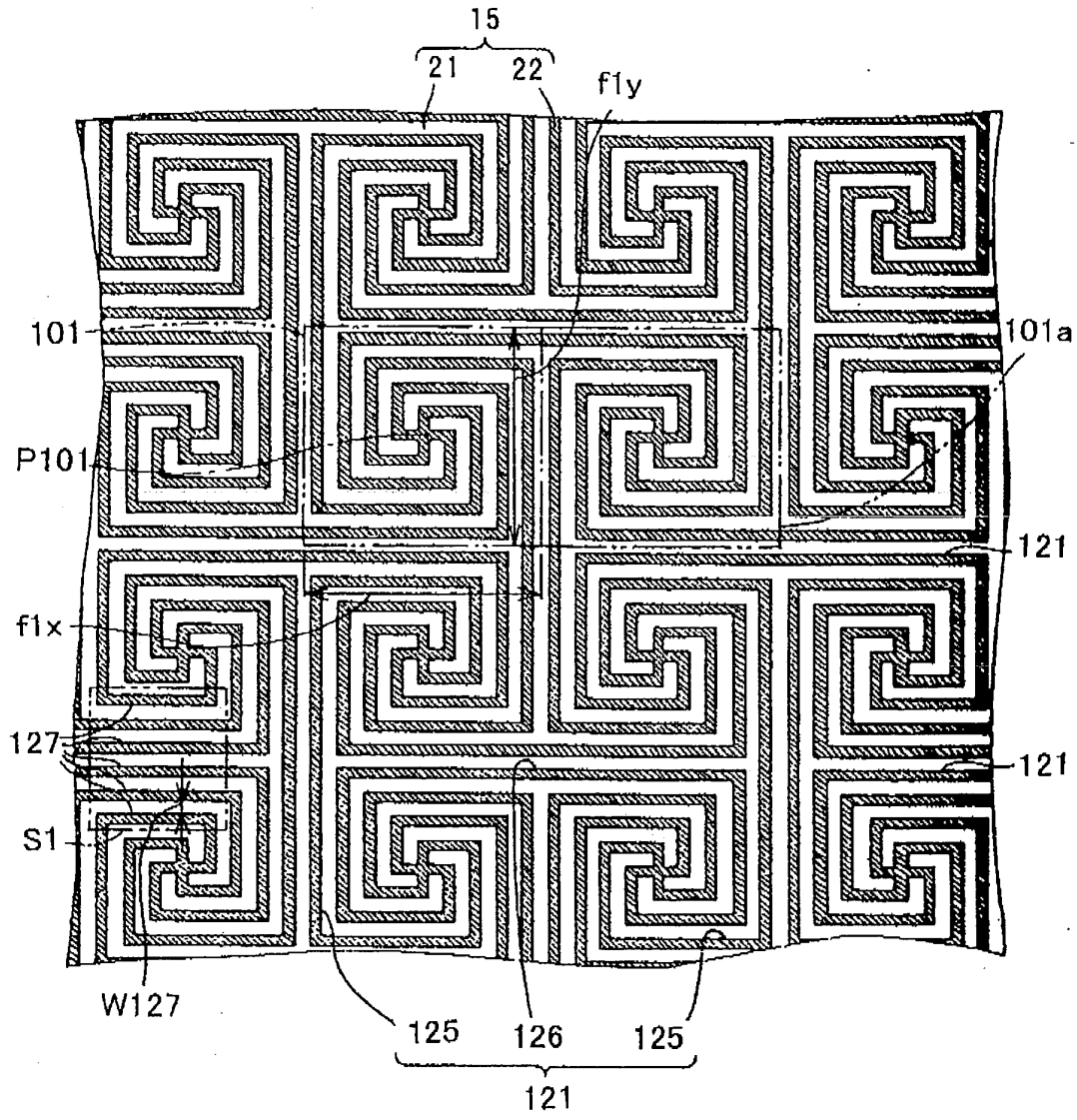


圖 37

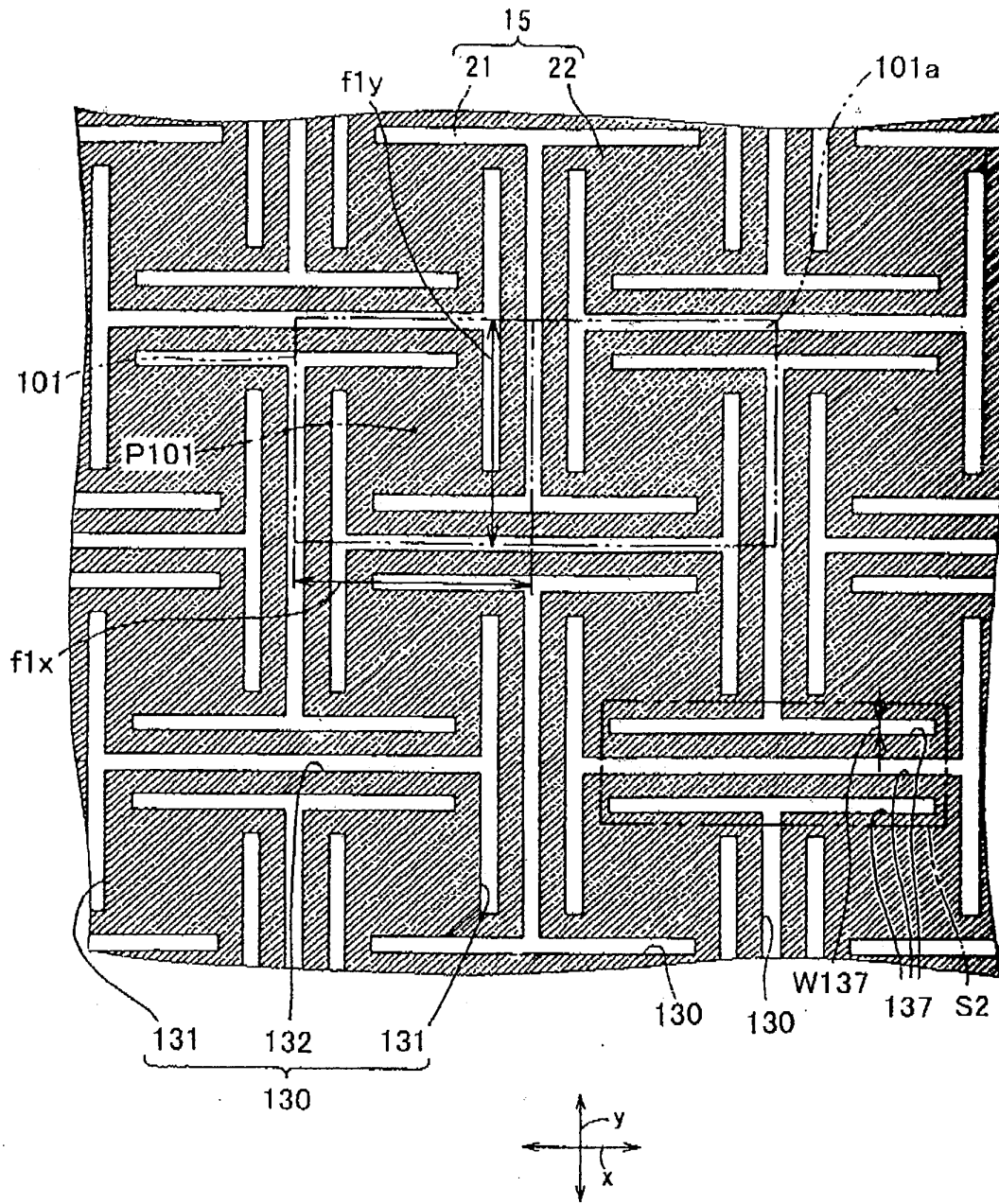


圖 38

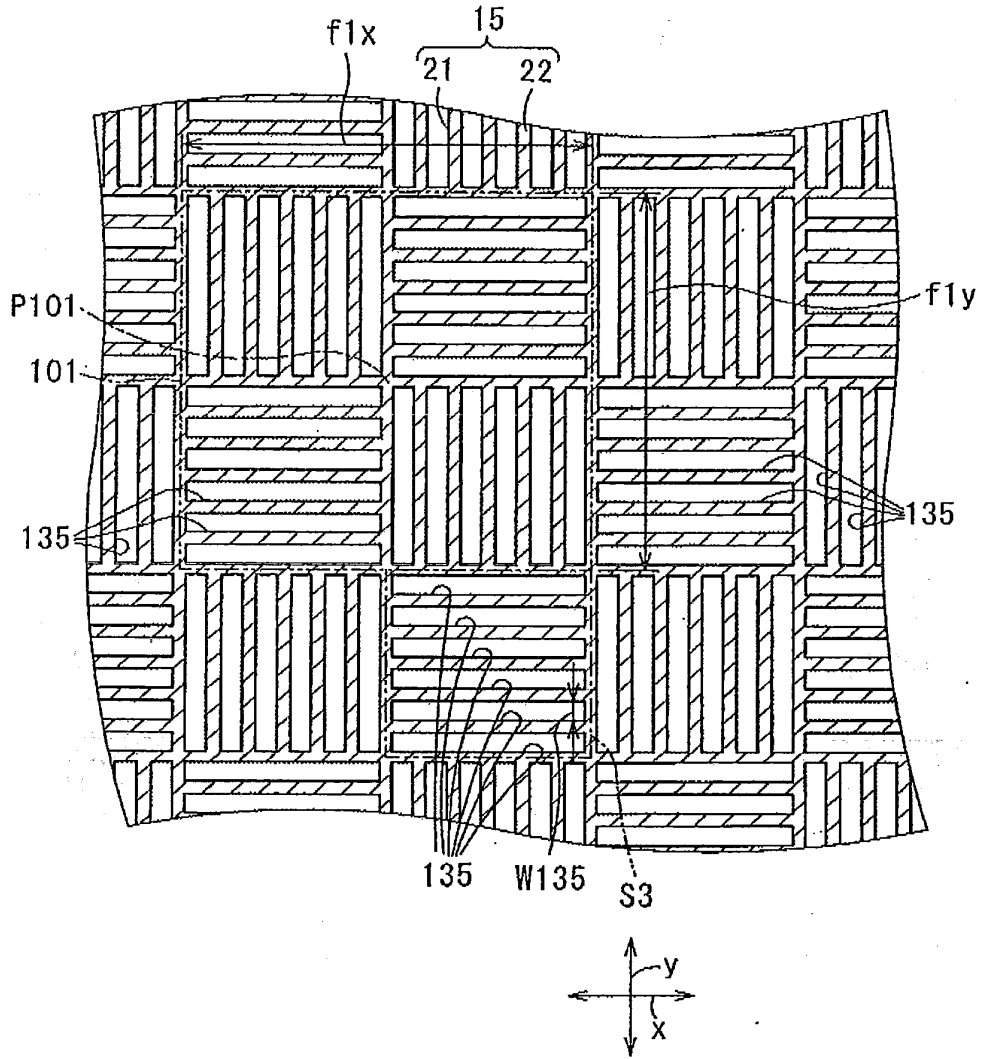


圖 39

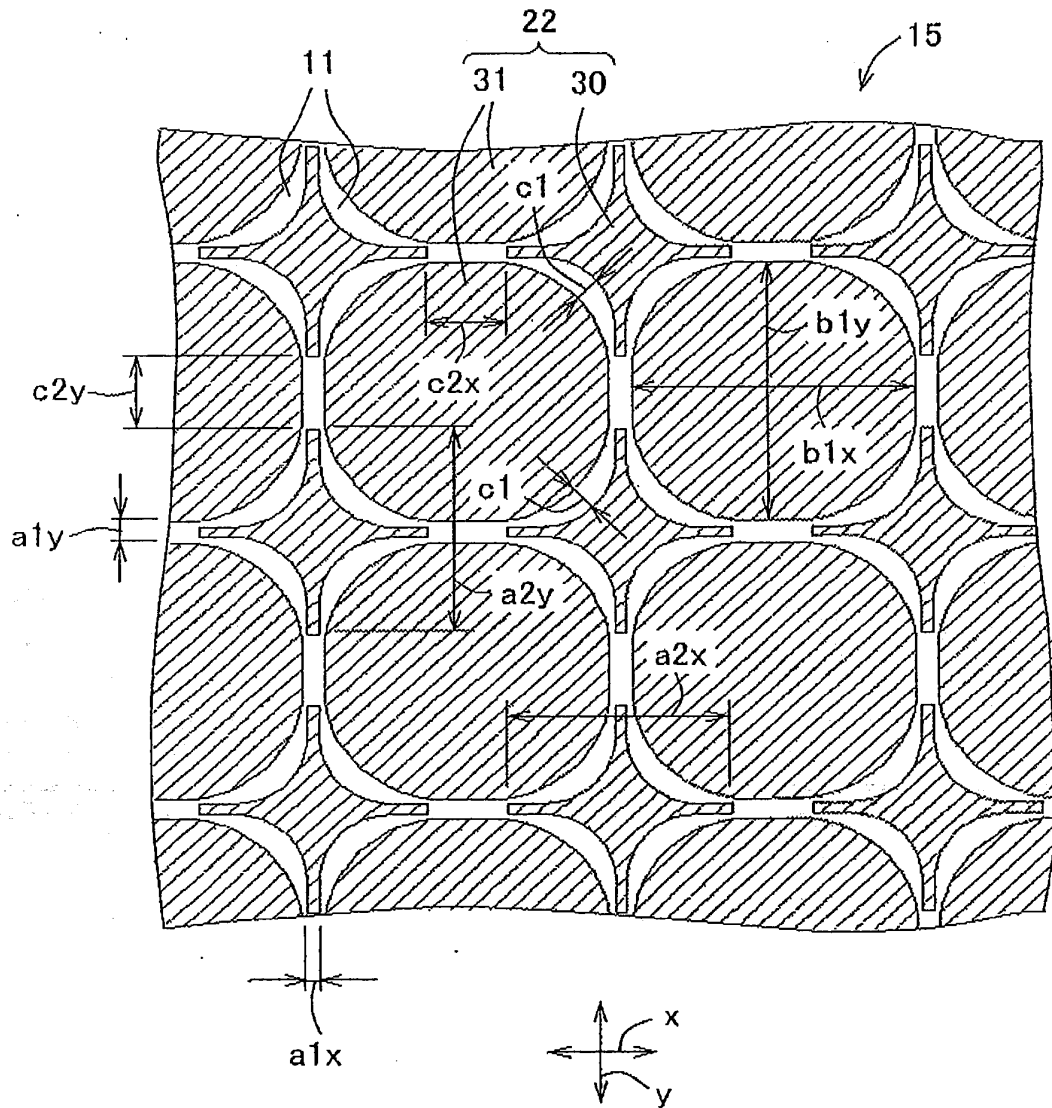


圖 40

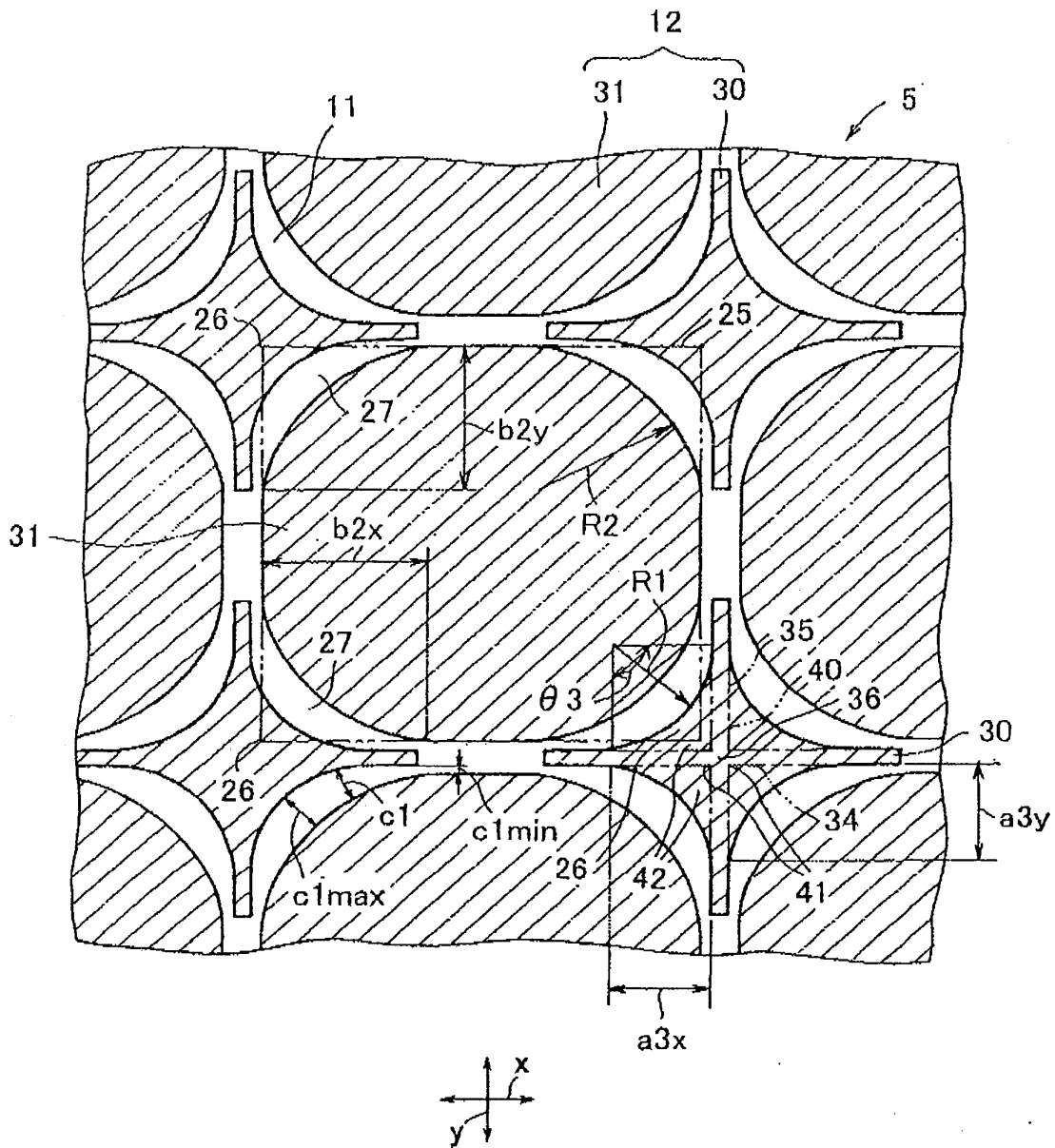


圖 41

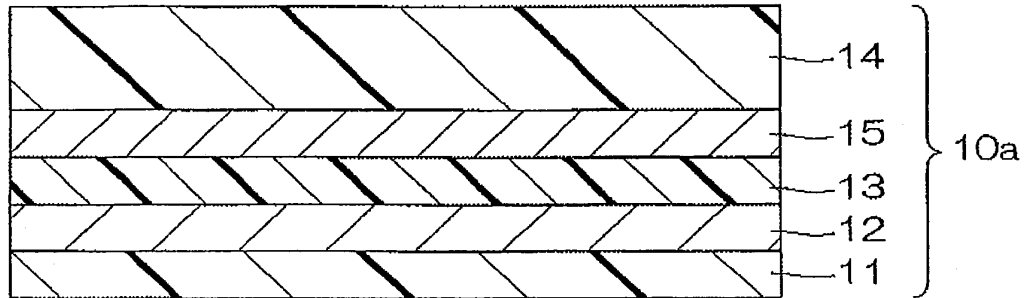


圖 42

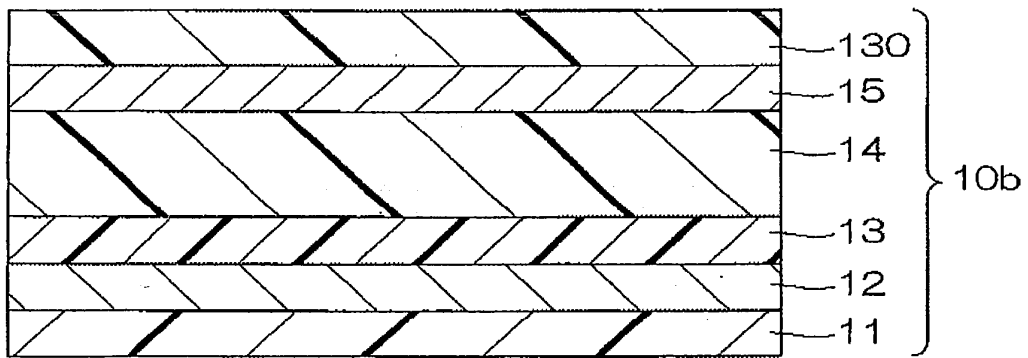


圖 43

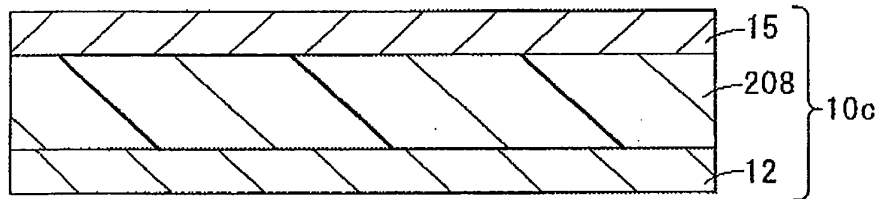


圖 44

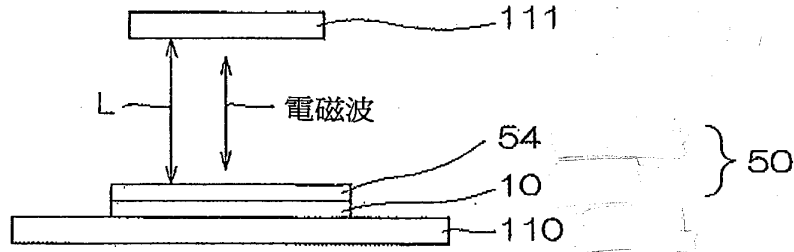


圖 45

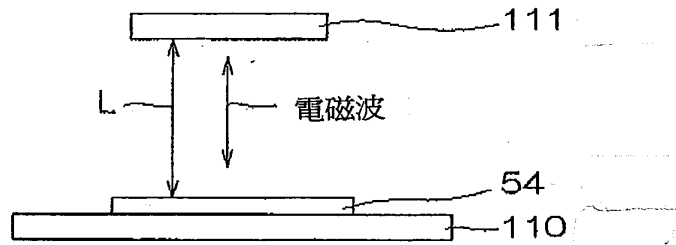


圖 46

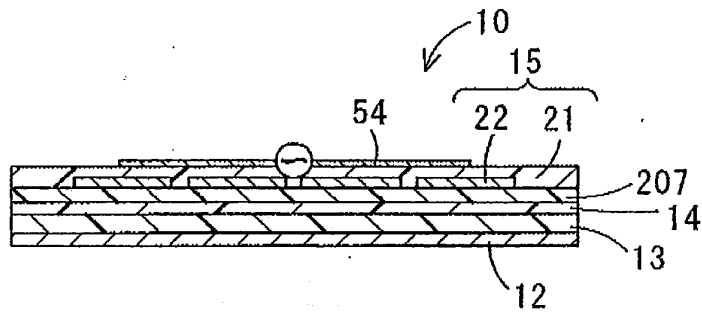


圖 47

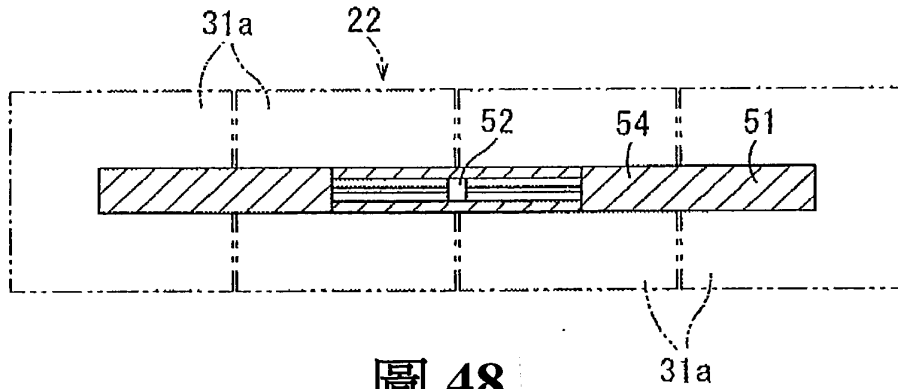


圖 48

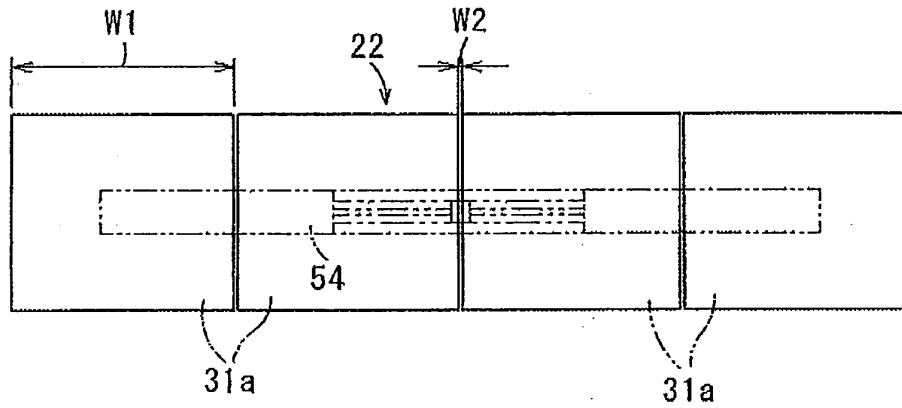


圖 49

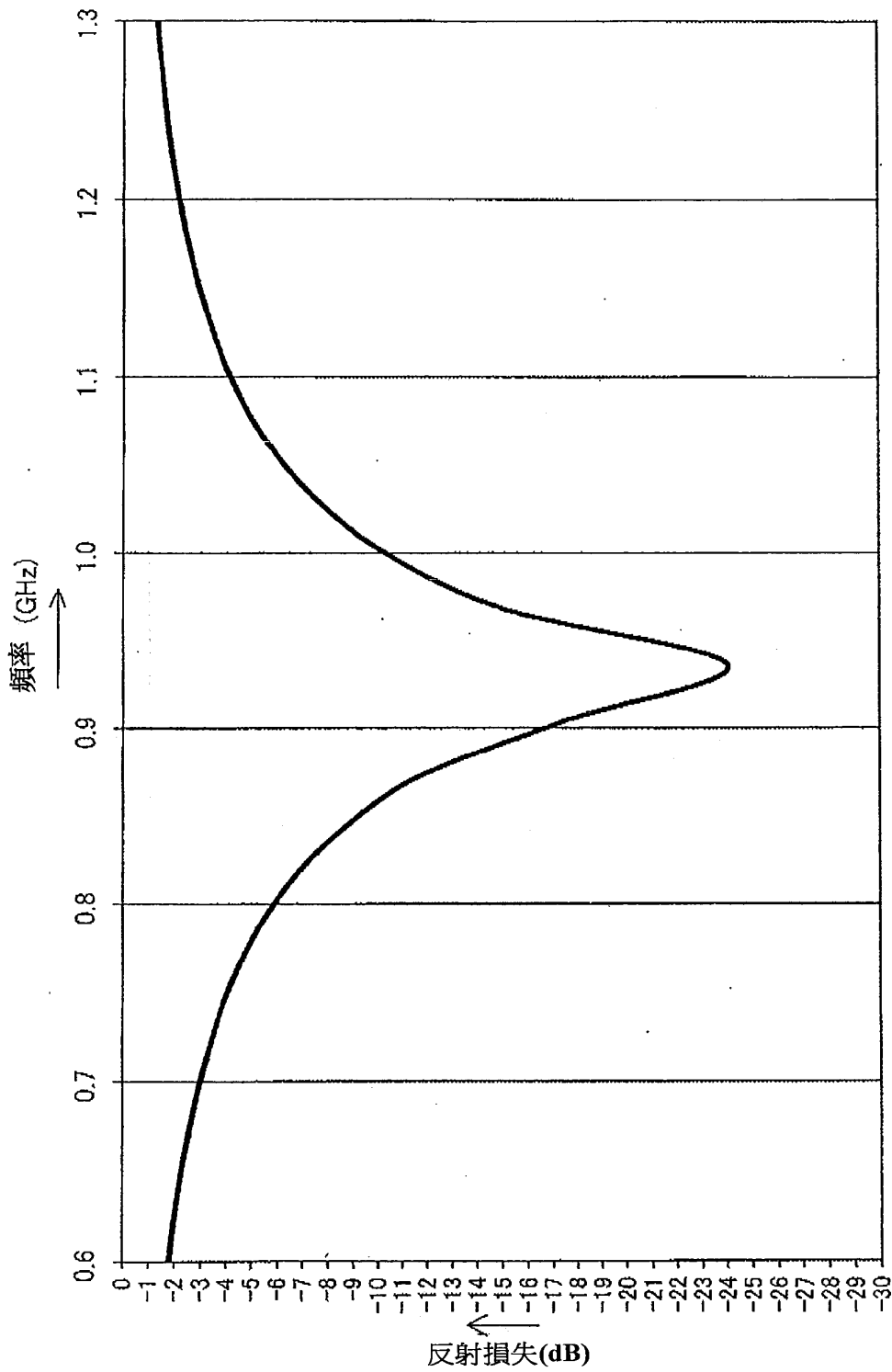


圖 50

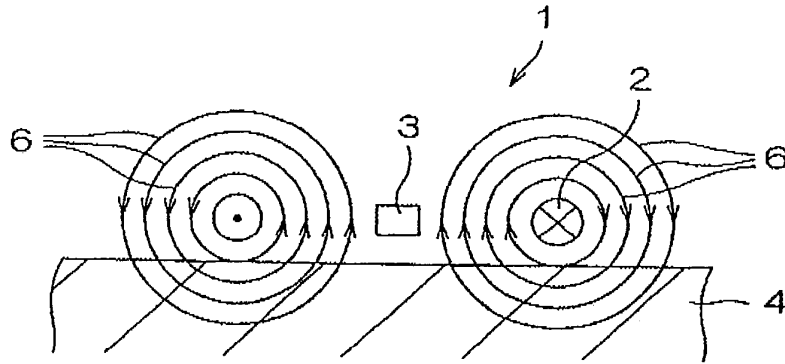


圖 51

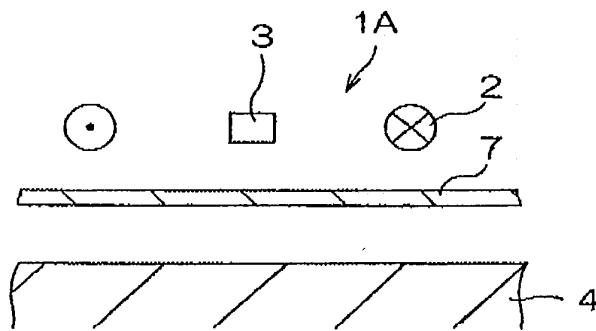


圖 52

200723596

七、指定代表圖：

(一)本案指定代表圖為：第(1)圖。

(二)本代表圖之元件符號簡單說明：

10	片體
11	貼合層
12	反射區域形成層
13	第二貯藏體層
14	第一貯藏體層
15	圖案層
16	表面層

八、本案若有化學式時，請揭示最能顯示發明特徵的化學式：

(無)



(11) **EP 2 096 711 A1**

(12) **EUROPEAN PATENT APPLICATION**
published in accordance with Art. 153(4) EPC

(43) Date of publication:
02.09.2009 Bulletin 2009/36

(21) Application number: **06812147.4**

(22) Date of filing: **23.10.2006**

(51) Int Cl.:
H01Q 15/14 (2006.01) **H01Q 1/38** (2006.01)
H01Q 9/16 (2006.01) **H01Q 17/00** (2006.01)
H01Q 19/10 (2006.01) **H05K 9/00** (2006.01)

(86) International application number:
PCT/JP2006/321087

(87) International publication number:
WO 2007/046527 (26.04.2007 Gazette 2007/17)

(84) Designated Contracting States:
**AT BE BG CH CY CZ DE DK EE ES FI FR GB GR
HU IE IS IT LI LT LU LV MC NL PL PT RO SE SI
SK TR**

(30) Priority: **21.10.2005 JP 2005307325**

(71) Applicant: **Nitta Corporation**
Osaka-shi,
Osaka 556-0022 (JP)

(72) Inventors:
• **GO, Haruhide**
Yamatokooriyama-shi, Nara 639-1085 (JP)
• **YOSHIDA, Takahiko**
Yamatokooriyama-shi, Nara 639-1085 (JP)
• **MATSUSHITA, Masato**
Yamatokooriyama-shi, Nara 639-1085 (JP)

- **KIYOHARA, Yoshiharu**
Yamatokooriyama-shi, Nara 639-1085 (JP)
- **SATO, Shinichi**
Yamatokooriyama-shi, Nara 639-1085 (JP)
- **YOSHIHARA, Ryota**
Yamatokooriyama-shi, Nara 639-1085 (JP)
- **MORITA, Kazuhisa**
Yamatokooriyama-shi, Nara 639-1085 (JP)
- **KOGURE, Hiroaki**
Tokyo 145-0071 (JP)

(74) Representative: **Ward, David Ian et al**
Marks & Clerk LLP
Alpha Tower
Suffolk Street
Queensway
Birmingham
B1 1TT (GB)

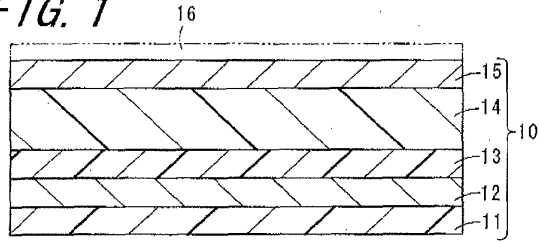
(54) **SHEET BODY FOR IMPROVING COMMUNICATION, ANTENNA DEVICE PROVIDED WITH SUCH SHEET BODY AND ELECTRONIC INFORMATION TRANSMITTING APPARATUS**

(57) A conductive pattern portion (22) formed in a pattern layer (15) functions as an antenna, and, when electromagnetic waves at a predetermined frequency arrive, resonance occurs, and an electromagnetic wave of a specific frequency is introduced into a sheet member (10). As to the sheet member (10) having the pattern layer (15), even in a small and thin sheet member, the phase of reflected waves from the reflection area can be adjusted, and thus an area having high electric field intensity due to interference between reflected waves from the reflection area and arriving electromagnetic waves

can be set in the vicinity of the antenna element. When the sheet member (10) is disposed between an antenna element (15) and a communication jamming member (57), an electromagnetic field is generated around the conductive pattern portion (22), and an electromagnetic energy is supplied from the conductive pattern portion to the antenna element (51), and therefore receiving power of the antenna element (51) can be increased. Accordingly, wireless communication can be suitably performed.

EP 2 096 711 A1

FIG. 1



Description

Technical Field

5 [0001] The present invention relates to a sheet member for improving communication, used for performing wireless communication using an antenna element in the vicinity of a communication jamming member, and an antenna device and an electronic information transmitting apparatus provided therewith,

Background Art

10

[0002] Fig. 51 is a simplified cross-sectional view showing a tag 1 according to a conventional technique. Fig. 51 shows the case of wireless communication using an electromagnetic induction system typically used for a 13.56 MHz band. An RFID (radio frequency identification) system is a system used for automatically recognizing a solid matter, and basically is provided with a reader and a transponder. As the transponder of this RFID system, the tag 1 is used. The tag 1 has a coil antenna 2 that is a magnetic field-type antenna detecting lines of magnetic force, and an integrated circuit (IC) 3 that is used for performing wireless communication using the coil antenna 2. In the tag 1, at the time when a request signal from the reader is received, information stored in the IC 3 is sent, that is, the reader is allowed to read information held in the tag 1. For example, the tag 1 is attached to a product, and used for management of products such as prevention of product theft or recognition of inventory status.

15

20

[0003] When a communication jamming member 4 (a conductive material in this example) is present in the vicinity of the antenna 2, for example, when the tag 1 is attached to a metal product in use, lines of magnetic force of a magnetic field that is formed by electromagnetic wave signals sent and received by the antenna 2 pass through points in the vicinity of the surface of the communication jamming member 4. In this case, an eddy current is formed at the communication jamming member 4, and electromagnetic wave energy is converted into thermal energy and absorbed. When the energy is absorbed in this manner, electromagnetic wave signals are significantly attenuated, which makes it impossible for the tag 1 to perform wireless communication. Furthermore, when the induced eddy current generates a magnetic field (diamagnetic field) in the orientation opposite to the magnetic field for communication of the tag, a phenomenon occurs in which the magnetic field is cancelled. This phenomenon also makes it impossible for the tag 1 to perform wireless communication. Furthermore, due to the influence of the communication jamming member 4, a phenomenon occurs in which the resonance frequency of the antenna 2 is shifted. Accordingly, the tag 1 cannot be used in the vicinity of the communication jamming member 4.

25

30

[0004] Fig. 52 is a simplified cross-sectional view showing a tag 1A according to another conventional technique. The tag 1A shown in Fig. 52 is similar to the tag 1 in Fig. 51, and thus the corresponding constituent elements are denoted by the same numerals, and only different constituent elements in the configuration will be described. In order to solve the problem of the tag 1 in Fig. 51, the tag 1A in Fig. 52 is configured to include a magnetic wave absorbing plate 7 disposed between the antenna 2 and the member 4 that is a product to which the tag 1A is attached. The magnetic wave absorbing plate 7, which is a sheet having a complex relative magnetic permeability, is made of a highly magnetically permeable material such as sendust, ferrite, or carbonyl iron, that is, a material having a high complex relative magnetic permeability.

35

40

[0005] The complex relative magnetic permeability has a real number part and an imaginary number part. When the real number part becomes high, the complex relative magnetic permeability becomes high. In other words, a material having a high complex relative magnetic permeability has a high real number part in the complex relative magnetic permeability. In a case where a material having a high real number part in the complex relative magnetic permeability is present in the magnetic field, lines of magnetic force concentratedly pass through the material. In the tag 1A that uses the magnetic field-type antenna 2 detecting lines of magnetic force, leakage of the magnetic field to the communication jamming member 4 is prevented by arranging the magnetic wave absorbing plate 7. Thus, even in the vicinity of the communication jamming member 4, the tag 1A can perform wireless communication while suppressing attenuation of magnetic field energy. This sort of tag 1A has been disclosed in, for example, Japanese Unexamined Patent Publication JP-A 2000-114132.

45

50

[0006] In another conventional technique, a sheet member is attached via an adhesive or the like to a non-contact wireless data carrier that is disposed near a wall face made of a metal or the like and that can send and receive predetermined radio waves, and thus this sheet member absorbs radio waves oriented toward the wall face or radio waves reflected by the wall face, thereby making it possible to send and receive data in the entire space in a radio wave area effective for the operation of the non-contact wireless data carrier. This example is for the RFID system in wireless communication using a radio wave method in a 2.4 GHz band. Furthermore, the non-contact wireless data carrier, a spacer that has a predetermined thickness and that does not absorb radio waves, and a radio wave reflecting members are attached to each other via an adhesive or the like, and the thickness of the spacer 8 is set so that the position of the non-contact wireless data carrier does not match a position away from the radio wave reflecting member by $\lambda/4$ (λ

55

denotes the wavelength) or a position away from that position by $n\lambda/2$ (the symbol n denotes a natural number), thereby making it possible to send and receive data in the entire space in a radio wave area effective for the operation of the non-contact wireless data carrier. A data carrier system using the non-contact wireless data carrier has been disclosed, for example, in Japanese Unexamined Patent Publication JP-A 2002-230507.

5 **[0007]** A communication jamming member in the invention refers to a member that may deteriorate communication properties of an antenna when the communication jamming member is present in the vicinity of the antenna, compared with the case of a free space. The communication jamming member corresponds to, for example, conductive materials such as metals, dielectric materials such as glass, paper, and a liquid, and magnetic materials having magnetic properties. In a case where a conductive material is present in the vicinity of an antenna element, the input impedance of the antenna element is significantly lowered, and thus wireless communication becomes difficult. Moreover, a dielectric material such as cardboard, a resin, glass, or a liquid jams wireless communication because the dielectric constant of the dielectric material lowers the resonance frequency of the antenna. Furthermore, a magnetic material also jams wireless communication because the magnetic permeability of the magnetic material lowers the resonance frequency of the antenna.

10 **[0008]** In a case where the magnetic-field-type antenna 2, such as a coil antenna is used as in the tag 1A shown in Fig. 52, leakage of a magnetic field is prevented, and thus wireless communication can be performed in the vicinity of the communication jamming member 4. However, this configuration has the problem that a sufficient communication distance cannot be typically secured with a magnetic field-type antenna. Furthermore, it is considered that this sort of configuration for preventing leakage of a magnetic field is not effective for a case in which an electric field-type antenna detecting lines of electric force is used, and the application thereof has not been investigated.

15 **[0009]** In JP-A 2002-230507, the radio wave reflecting member is overlaid via a sheet member or a spacer on the non-contact wireless data carrier, and thus the position of the data carrier is set so as not to match a position away from the radio wave reflecting member by $\lambda/4$ or a position away from that position by $n\lambda/2$ (n is a natural number). JP-A 2002-230507 describes that a point where data cannot be sent or received due to mutual cancellation of incident waves and reflected waves appears in each point away from the reflecting face by $\lambda/4$ and point away from that position by $\lambda/2$. However, as shown in Fig. 12 by the present inventors, the phase of radio waves is shifted by 180° when the radio waves are reflected by the radio wave reflecting face, and thus the position away from the radio wave reflecting face by $\lambda/4$ has the largest electric field intensity due to interference. At the same time, the magnetic field intensity at this position becomes zero. That is to say, although data cannot be received by a magnetic field-type antenna, data can be received optimally by a commonly used electric field-type antenna. Thus, in a case where this position is not included, there is the problem that a sufficient communication distance cannot be secured in the vicinity of the communication jamming member.

20 **[0010]** The problem in the shift of the resonance frequency is that since the shift varies depending on a material (material quality) that is present in the vicinity, the shift amount is not constant, and thus a measure for improving communication (modifying resonance frequency) is individually required.

35 Disclosure of Invention

[0011] It is an object of the invention to provide, instead of a radio wave absorbing member that attenuates electromagnetic energy, a sheet member for improving communication, capable of storing communication energy and enabling wireless communication to be suitably performed in the vicinity of a communication jamming member, and an antenna device and an electronic information transmitting apparatus provided therewith.

40 **[0012]** The invention is directed to a sheet member for improving communication used when performing wireless communication using an antenna element in a vicinity of a communication jamming member, the sheet member being disposed between the antenna element and the communication jamming member, and comprising a pattern layer in which a conductive pattern portion is formed.

45 **[0013]** According to the invention, the conductive pattern portion of the pattern layer functions as an antenna, and resonance occurs when electromagnetic waves at a predetermined frequency arrive. In a case where an antenna element such as a dipole antenna is disposed in the vicinity of the pattern layer, electromagnetic coupling is formed between the conductive pattern layer and the antenna element, and electromagnetic energy stored in the pattern layer is transferred from the conductive pattern portion to the antenna element. When electromagnetic energy at the resonance frequency is supplied from the conductive pattern portion to the antenna element, receiving power of the antenna element can be increased compared with a case in which this pattern layer is not included. Accordingly, wireless communication can be suitably performed even in the vicinity of a communication jamming member, and a sufficient communication distance can be secured. When the sheet member includes the conductive pattern portion and independently has an antenna function in this manner, an effect of improving communication of antenna element can be obtained. The sheet member for improving communication of the invention is designed so that the sheet member itself is not affected by a communication jamming member and the sheet member itself does not negatively affect the antenna element. Furthermore, the sheet member has a structure in which electromagnetic energy used for communication is completed for the antenna

element.

[0014] Furthermore, in the invention, it is preferable that the sheet member for improving communication further comprises a storage layer that is made of a non-conductive dielectric layer and/or magnetic layer and that collects energy of electromagnetic waves used for wireless communication.

5 **[0015]** According to the invention, when the antenna element is disposed in the vicinity of a communication jamming member, since the storage layer that collects energy of electromagnetic waves used for wireless communication is disposed between the antenna element and the communication jamming member, conduction can be prevented, and reactance (L) components and capacitance (C) components can be increased. Furthermore, due to a real number part ϵ' of the complex relative dielectric constant and/or a real number part μ' of the complex relative magnetic permeability, the propagation path of electromagnetic waves that have entered the sheet member can be bent. Moreover, due to a wavelength shortening effect, the conductive pattern portion and the sheet member can be made smaller and thinner. The storage layer is made of at least one of a non-conductive magnetic layer and dielectric layer.

10 **[0016]** Furthermore, when the antenna element is disposed in the vicinity of a communication jamming member, since the non-conductive storage layer is disposed between the antenna element and the communication jamming member, a decrease in the input impedance of the antenna element caused by the communication jamming member can be suppressed. When the input impedance becomes small, this impedance is deviated from the impedance of communication means for performing communication using the antenna element, and signals cannot be exchanged between the antenna element and the communication means. Since the sheet member can suppress a decrease in the input impedance of the antenna element when the antenna element is disposed in the vicinity of a communication jamming member, wireless communication can be suitably performed even in the vicinity of a communication jamming member.

15 **[0017]** Furthermore, in the invention, it is preferable that a reflection area forming layer that forms a reflection area reflecting electromagnetic waves used for wireless communication is disposed to have the storage layer interposed between the reflection area forming layer and the pattern layer, and to be spaced away from the pattern layer on the opposite side of the antenna element, in the vicinity of a position at which the electrical length from the pattern layer is $((2n-1)/4)\lambda$ (n is a positive integer) when the wavelength of electromagnetic waves used for wireless communication is taken as λ .

20 **[0018]** According to the invention, electromagnetic waves at a specific frequency are captured by the interior of the sheet member by resonance, and the phase of the captured electromagnetic waves is adjusted in the interior of the sheet member. Thus, when the wavelength of electromagnetic waves used for wireless communication is taken as λ , an area having high electric field intensity, formed at a position away from the reflection area by an electrical length of $((2n-1)/4)\lambda$ (n is a positive integer), can be formed at the position of the pattern layer. Since the phase of electromagnetic waves reflected at a reflection area that is formed by the reflection area forming layer is shifted by 180° , when arriving electromagnetic waves and electromagnetic waves reflected at the reflection area interfere each other, the electric field intensity is increased at a position away from the reflection area by an electrical length of $((2n-1)/4)$ times of the wavelength of electromagnetic waves. When the antenna element is disposed at a position where reflected electromagnetic waves and arriving electromagnetic waves reinforce each other for interference, that is, the pattern layer is disposed in the vicinity of the antenna element in an electrically insulated state, the intensity of an electric field that can be received by the antenna element can be prevented from being lowered, and wireless communication can be suitably performed even in the vicinity of a communication jamming member.

25 **[0019]** Furthermore, the reflection area may be the reflection area forming layer itself, or may be a position (virtual electromagnetic wave reflecting face) having an electric field of zero and virtually connecting a point near the center of the conductive pattern portion and the reflection area forming layer. In a case where the reflection area is a position (virtual electromagnetic wave reflecting face) having an electric field of zero and virtually connecting a point near the center of the conductive pattern portion and the reflection area forming layer, electromagnetic waves are reflected at that position, and electromagnetic waves move around the conductive pattern portion. Using these aspects, a longer electrical length from the conductive pattern portion to the reflection area can be obtained. As a result, the thickness of the sheet member can be made smaller than $((2n-1)/4)\lambda$ (n is a positive integer), and thus the sheet member can be made thinner.

30 **[0020]** Furthermore, in a case where the reflection area forming layer is disposed, the influence of the arrangement position of the sheet member, that is, the type of materials constituting the communication jamming member and presence of liquid such as water attached to the surface of the communication jamming member can be prevented from changing the resonance frequency of the conductive pattern portion. Thus, the optimum conditions of communication do not have to be readjusted for each different antenna element, and the communication conditions of the antenna element can be stabilized.

35 **[0021]** Furthermore, in the invention, it is preferable that a plurality of conductive pattern portions that are electrically insulated from each other are formed in the pattern layer.

40 **[0022]** According to the invention, with the pattern layer, electromagnetic waves corresponding to the size of each of the conductive pattern portions can be received to cause resonance. Depending on how the size of the conductive

pattern portions is determined, electric power obtained by the antenna element from electromagnetic waves used for wireless communication can be increased. Herein, the number of pattern portions resonated with electromagnetic waves at a communication frequency may be one or may be plural. The pattern layer may be a single layer or may be multiple layers. The pattern layer may be formed in three dimensions.

5 [0023] Furthermore, in the invention, it is preferable that a plurality of types of conductive pattern portions in which at least one of size and shape is different therebetween are formed in the pattern layer.

[0024] According to the invention, a plurality of types of conductive pattern portions in which at least one of size and shape is different therebetween have respectively different resonance frequencies, and thus the pattern layer can receive electromagnetic waves at a plurality frequencies. Furthermore, the electric power obtained by the antenna element from electromagnetic waves used for wireless communication can be reliably increased.

10 [0025] Furthermore, in the invention, it is preferable that a conductive pattern portion that continuously extends over a wide range of the sheet member is formed in the pattern layer.

[0026] According to the invention, the pattern layer in which the conductive pattern portion continuously disposed in a wide range is formed can increase the gain over frequencies in a wide band. Thus, the sheet member provided therewith can receive electromagnetic waves at frequencies in a wide band. Furthermore, the electric power obtained by the antenna element from electromagnetic waves used for wireless communication can be reliably increased.

15 [0027] Furthermore, in the invention, it is preferable that the conductive pattern portion has a substantially polygonal outer shape in which at least one corner is curved.

[0028] The conductive pattern portion that receives electromagnetic waves has a substantially polygonal outer shape that is basically in the shape of a polygon, and at least one corner is curved. When the corner is rounded off, that is, curved, shift of the frequency at which the gain has a peak value according to the direction in which electromagnetic waves are polarized can be suppressed low, and good polarization properties can be obtained. Accordingly, an excellent sheet member for improving communication can be realized in which a peak value of the gain is high, and shift of the frequency at which the gain has a peak value according to the direction in which electromagnetic waves are polarized is small.

20 [0029] In the pattern layer, all conductive pattern portions may have curved corners. However, all conductive pattern portions do not have to have curved corners, and any configuration may be applied, as long as part of the conductive pattern portions has curved corners. In a case where part of the conductive pattern portions has curved corners, there is no limitation on presence or absence of curved corners in the other conductive pattern portions. Furthermore, in the conductive pattern portions that have curved corners, only part of the corners may be curved, or all corners may be curved. Furthermore, the conductive pattern portion may be in the shape of a substantially polygonal plane, or may be in the shape of a line forming a closed loop extending substantially in the shape of a polygon. Accordingly, the electric power obtained by the antenna element from electromagnetic waves used for wireless communication can be reliably increased.

25 [0030] Furthermore, in the invention, it is preferable that a plurality of conductive pattern portions are formed in the pattern layer, and the conductive pattern portions have different radiuses of curvature of corners and are formed in combination.

[0031] According to the invention, since the conductive pattern portions having different radiuses of curvature of the corners are formed, the frequency band of electromagnetic waves that are to be received (hereinafter, may be referred to as a 'reception band') can be changed without lowering a peak value of the gain, compared with a case in which only conductive pattern portions having the same radius of curvature of the corners are formed. Changing the reception band includes widening the reception band and changing the reception frequency. For example, in a case where the radius of curvature of the corners is slightly different between adjacent conductive pattern portions, the reception band can be widened without lowering a peak value of the gain. Furthermore, for example, in a case where the difference in the radius of curvature of the corners between adjacent conductive pattern portions is slightly larger, the frequency of electromagnetic waves that are to be received (hereinafter, may be referred to as a 'reception frequency') can be widened to the lower side without lowering a peak value of the gain.

30 [0032] Furthermore, in the invention, it is preferable that a plurality of conductive pattern portions are formed in the pattern layer, and a gap between two adjacent conductive pattern portions varies depending on the position.

35 [0033] According to the invention, the gain can be increased compared with a case in which the gap between two adjacent conductive pattern portions is constant.

[0034] Furthermore, in the invention, it is preferable that a frequency of electromagnetic waves used for wireless communication is included in the range of at least 300 MHz and not greater than 300 GHz.

40 [0035] According to the invention, wireless communication can be suitably performed using electromagnetic waves having a frequency of 300 MHz or higher and 300 GHz or lower. The range of 300 MHz or higher and 300 GHz or lower includes a UHF band (300 MHz to 3 GHz), an SHF band (3 GHz to 30 GHz) and an EHF band (30 GHz to 300 GHz).

45 [0036] Furthermore, in the invention, it is preferable that a total thickness is not greater than 50 mm.

50 [0037] According to the invention, the thickness of the sheet member for enabling wireless communication to be

suitably performed using electromagnetic waves at a frequency in the range of 300 MHz or higher and 300 GHz or lower can be made as small as possible, and thus the sheet member can be made thinner.

[0038] Furthermore, in the invention, it is preferable that the frequency of electromagnetic waves used for wireless communication is included in any one of frequency bands (hereinafter, referred to as a high MHz band) in the range of at least 860 MHz band and less than 1,000 MHz band, and a total thickness is not greater than 15 mm,

[0039] According to the invention, the thickness of the sheet member for enabling wireless communication to be suitably performed using electromagnetic waves at a frequency included in a high MHz band can be made as small as possible, and thus the sheet member can be made thinner.

[0040] Furthermore, in the invention, it is preferable that the frequency of electromagnetic waves used for wireless communication is included in a 2.4 GHz band, and a total thickness is not greater than 8 mm.

[0041] According to the invention, the thickness of the sheet member for enabling wireless communication to be suitably performed using electromagnetic waves at a frequency included in a 2.4 GHz band can be made as small as possible, and thus the sheet member can be made thinner.

[0042] Furthermore, in the invention, it is preferable that the storage layer is made of a material in which one or a plurality of materials selected from the group consisting of ferrite, iron alloy, and iron particles are contained as a magnetic material in an amount blended of at least 1 part by weight and not greater than 1500 parts by weight, with respect to 100 parts by weight of an organic polymer.

[0043] According to the invention, the storage layer can be provided with a complex relative magnetic permeability (μ' , μ''), and thus a sheet member achieving the above-described effect can be suitably realized.

[0044] Furthermore, in the invention, it is preferable that the sheet member for improving communication is flame-resistant.

[0045] According to the invention, the sheet member can be flame-resistant. For example, an electronic information transmitting apparatus that performs wireless communication using an antenna element, such as tags, readers, and portable telephones may be required to be flame-resistant. The sheet member can be suitably used also for the application where flame resistance is required.

[0046] Furthermore, in the invention, it is preferable that at least one surface portion is glutinous or adhesive.

[0047] According to the invention, at least one surface portion is glutinous or adhesive. Thus, the sheet member can be attached to other articles such as the above-described communication jamming member. Accordingly, the sheet member can be easily used.

[0048] Moreover, the invention is directed to an antenna device, comprising:

an antenna element that has a resonance frequency matched to a frequency used for wireless communication; and the sheet member for improving communication mentioned above.

[0049] According to the invention, the sheet member is disposed between the antenna element and a communication jamming member. Thus, in a state where the antenna device is disposed in the vicinity of a communication jamming member, the antenna device can be used for suitably performing wireless communication using the antenna element, and for transmitting electronic information. In this manner, an antenna device that can be suitably used in the vicinity of a communication jamming member can be realized.

[0050] Moreover, the invention is directed to an electronic information transmitting apparatus comprising the antenna device mentioned above.

[0051] According to the invention, an electronic information transmitting apparatus can be realized that can suitably perform wireless communication using the antenna device including the antenna element even in a state where the electronic information transmitting apparatus is disposed in the vicinity of a communication jamming member.

Brief Description of Drawings

[0052] Other and further objects, features, and advantages of the invention will be more explicit from the following detailed description taken with reference to the drawings wherein:

- Fig. 1 is a cross-sectional view of a sheet member 10 according to an embodiment of the invention;
- Fig. 2 is an enlarged cross-sectional view showing the internal structure of a first storage layer 14;
- Fig. 3 is a front view showing a pattern layer 15 constituting the sheet member 10 according to an embodiment of the invention;
- Fig. 4 is an enlarged front view of a part of the pattern layer 15 in the embodiment shown in Fig. 3;
- Fig. 5 is an enlarged front view of a part of the pattern layer 15 in the embodiment shown in Fig. 3;
- Fig. 6 is a graph showing a calculation result obtained with a simulation of the resonance frequency that is changed by the influence of cutting of conductive pattern portions 22;

EP 2 096 711 A1

Fig. 7 is a front view showing a pattern shape of the conductive pattern portion 22 of the sheet member 10 used in the simulation;

Fig. 8 is an exploded perspective view showing a tag 50 including the sheet member 10;

Fig. 9 is a view showing a state in which the tag 50 is attached to a communication jamming member 57;

5 Fig. 10 is a cross-sectional view showing electromagnetic coupling between an antenna element 51 and a pattern layer 15 and electromagnetic coupling between the pattern layer 15 and a radio wave reflecting layer 12;

Fig. 11 is a schematic view showing electromagnetic waves that are incident on the sheet member 10 (referred to as traveling waves) and Electromagnetic waves that are reflected by the sheet member 10 (referred to as reflected waves);

10 Fig. 12 is a view illustrating reflection of electromagnetic waves;

Fig. 13 is an enlarged schematic view showing a part of the sheet member 10 shown in Fig. 11;

Fig. 14 is an enlarged perspective view showing a part of the tag 50, in which a part of a tag main body 54 overlaid on the sheet member 10 is cut out;

Fig. 15 is a view showing the electric field intensity obtained by a simulation performed in a region indicated by a virtual line 48 shown in Fig. 14;

15 Fig. 16 is an enlarged perspective view showing a part of the pattern layer 15, which is another embodiment constituting the sheet member 10 in the embodiment shown in Fig. 1;

Fig. 17 is an enlarged perspective view showing a part of the pattern layer 15 according to another embodiment constituting the sheet member 10 in the embodiment shown in Fig. 1;

20 Fig. 18 is an enlarged perspective view showing a part of the pattern layer 15 according to another embodiment constituting the sheet member 10 in the embodiment shown in Fig. 1;

Fig. 19 is a front view of the pattern layer 15 according to another embodiment constituting the sheet member 10 in the embodiment shown in Fig. 1;

Fig. 20 is an enlarged perspective view showing a part of the pattern layer 15 in Fig. 19;

25 Fig. 21 is a front view of the pattern layer 15 showing double-humped properties according to another embodiment constituting the sheet member 10 in the embodiment shown in Fig. 1;

Fig. 22 is an enlarged perspective view of a part of the pattern layer 15 in the embodiment shown in Fig. 21;

Fig. 23 is a front view of the pattern layer 15 showing double-humped properties according to another embodiment constituting the sheet member 10 in the embodiment shown in Fig. 1;

30 Fig. 24 is an enlarged perspective view of a part of the pattern layer 15 in the embodiment shown in Fig. 23;

Fig. 25 is a front view of the pattern layer 15 according to another embodiment constituting the sheet member 10 in the embodiment shown in Fig. 1;

Fig. 26 is an enlarged perspective view showing a part of the pattern layer 15 shown in Fig. 25;

35 Fig. 27 is a front view showing the pattern layer 15 according to another embodiment constituting the sheet member 10 in the embodiment shown in Fig. 1;

Fig. 28 is a front view showing the pattern layer 15 according to another embodiment constituting the sheet member 10 in the embodiment shown in Fig. 1;

Fig. 29 is an enlarged perspective view showing a part of the pattern layer 15 shown in Fig. 28; .

40 Fig. 30 is a front view of the pattern layer 15 according to still another embodiment constituting the sheet member 10 in the embodiment shown in Fig. 1;

Fig. 31 is a front view of the pattern layer 15 according to still another embodiment constituting the sheet member 10 in the embodiment shown in Fig. 1;

Fig. 32 is a front view showing a rectangular pattern shape 71 according to another embodiment.

45 Fig. 33 is a front view showing a radial pattern shape 70 accordin to still another embodiment of the invention;

Fig. 34 is a front view of the pattern layer 15 accordint to still another embodiment constituting the sheet member 10 in the embodiment shown in Fig. 1;

Fig. 35 is a front view showing another pattern layer 15 whose configuration is different in size from that of the pattern layer 15 in Fig. 34, accordint to still another embodiment of the invention;

50 Fig. 36 is a front view showing another pattern layer 15 that can be used as still another embodiment of the invention;

Fig. 37 is a front view showing another pattern layer 15 that can be used as still another embodiment of the invention;

Fig. 38 is a front view showing another pattern layer 15 that can be used as still another embodiment of the invention;

Fig. 39 is a front view showing another pattern layer 15 that can be used as still another embodiment of the invention;

Fig. 40 is an enlarged front view showing a part of the pattern layer 15 according to another embodiment constituting the sheet member 10 in the embodiment shown in Fig. 1;

55 Fig. 41 is a front view of the pattern layer 15 in which a part of Fig. 40 is enlarged;

Fig. 42 is a cross-sectional view showing a sheet member 10a according to still another embodiment of the invention;

Fig. 43 is a cross-sectional view showing a sheet member 10b according to still another embodiment of the invention;

Fig. 44 is a cross-sectional view showing a sheet member 10c according to still another embodiment of the invention;

Fig. 45 is a schematic view showing the manner of a communication test;
 Fig. 46 is a schematic view showing the manner of a communication test;
 Fig. 47 is a graph showing a calculation result obtained with a simulation of the reflection loss of the sheet member 10 in Example 7;
 5 Fig. 48 is a cross-sectional view showing the sheet member 10 of Example 8;
 Fig. 49 is a plan view showing the tag main body 54 that is attached to the sheet member 10 of Example 8;
 Fig. 50 is a plan view showing the pattern layer 15 constituting the sheet member 10 of Example 8;
 Fig. 51 shows the case of wireless communication using an electromagnetic induction system typically used for a 13.56 MHz band; and
 10 Fig. 52 is a simplified cross-sectional view showing a tag 1A according to another conventional technique.

Best Mode for Carrying out the Invention

[0053] Now referring to the drawings, preferred embodiments of the invention are described below.

15 [0054] Fig. 1 is a cross-sectional view of a sheet member for improving communication (hereinafter, referred to as a sheet member) 10 according to an embodiment of the invention. The sheet member 10 is a sheet for suitably performing wireless communication using an antenna element in the vicinity of a communication jamming member, and is disposed between the antenna element and the communication jamming member.

[0055] The sheet member 10 is in the shape of a sheet, and has a pattern layer 15, a first storage layer 14, a reflection area forming layer 12, and an attachment layer 11. The sheet member 10 also has a second storage layer 13. The layers 11 to 15 are overlaid in the following order; the pattern layer 15, the first storage layer 14, the second storage layer 13, the reflection area forming layer 12, and then the attachment layer 11, from the electromagnetic wave incident side, which is one side in the thickness direction (overlaid direction) that is the upper side in Fig. 1. The sheet member 10 has this sort of layer configuration. On the electromagnetic wave incident side (the upper side in Fig. 1) of the pattern layer 15, a surface layer 16 that is not a layer reflecting electromagnetic waves, also may be formed. Hereinafter, for facilitating understanding, the storage layers 14 and 13 may be referred to as storage layers.

[0056] In this embodiment, essential constituent elements of the sheet member 10 are the pattern layer 15, the storage layers, and the reflection area forming layer 12. The reflection area forming layer 12 may not be included in the sheet member 10 when the sheet member 10 is used in contact with an electromagnetic wave reflecting plate (for example, a metal) having the function of the reflection area forming layer 12. In the pattern layer 15, conductive pattern portions 22 functioning as an antenna are formed. The storage layers are layers containing a non-conductive dielectric layer and/or magnetic layer. The layers have a real number part ϵ' of the complex relative dielectric constant and/or a real number part μ' of the complex relative magnetic permeability, and are made of a material in which an imaginary number part ϵ'' of the complex relative dielectric constant and/or an imaginary number part μ'' of the complex relative magnetic permeability, which are loss components of the real number parts, is suppressed to the lowest to the extent possible. The storage layers are positioned in the vicinity of the pattern layer 15. With the real number part ϵ' of the complex relative dielectric constant and/or the real number part μ' of the complex relative magnetic permeability, a propagation path of electromagnetic waves that have entered the sheet member 10 can be bent. Furthermore, with a wavelength shortening effect, the conductive pattern portions 11 and the sheet member 10 can be made smaller and thinner. The range of the real number part ϵ' of the complex relative dielectric constant of the sheet member 10 is 1 to 200 in a communication frequency band. The range of the real number part μ' of the complex relative magnetic permeability is 1 to 100 in a communication frequency band. Preferably, materials with high ϵ' and/or high μ' are positioned close to the conductive pattern portions 11, which makes it easy to obtain a wavelength shortening effect. The storage layer may be either a single layer or multiple layers, and also may contain an air layer. For example, a foam, a resin, paper, an adhesive, a glue, or the like can be used as the storage layer (dielectric layer). For example, the sheet member 10 may have a configuration in which the pattern layer 15, an adhesive layer (high dielectric constant), a foam layer (low loss), and the reflection area forming layer 12 are overlaid in this order. In this configuration, an adhesive containing a dielectric material or the like is used because a wavelength shortening effect from the storage layers can be more easily provided as being closer to the pattern layer 15, and a dielectric material with low loss is used in order to secure the distance between the conductive pattern portions 22 and the reflection area forming layer 12. Thus, communication is improved while the weight is made lighter and the price is made lower. The adhesive layer and the foam layer correspond to the storage layers in the invention. It will be appreciated that the configuration is not limited to this, and various materials can be combined.

[0057] The configuration shown in Fig. 1 includes the first and the second storage layers 14 and 13 as the storage layers. The storage members include a member having a dielectric property made of a dielectric material (hereinafter, may be referred to as a 'dielectric member') and a magnetic member made of a magnetic material. The first and the second storage layers 14 and 13 are made of a material that is at least one of a magnetic member having the complex relative magnetic permeability (μ' , μ'') and a dielectric member having the complex relative dielectric constant (ϵ' , ϵ'').

Both of the materials may be a magnetic member, both of the materials may be a dielectric member, or one of the materials may be a dielectric member and the other may be a magnetic member. The invention also encompasses the configuration in which the first storage layer 14 that may be either a dielectric member or a magnetic member is used and the second storage layer 13 is not included. In this embodiment, the first storage layer 14 is a magnetic member, and the second storage layer 13 is a dielectric member.

[0058] The reflection area forming layer 12 is configured as a conductive film that is formed throughout the entire surface of the second storage layer 13 on the opposite side of the electromagnetic wave incident side, and reflects electromagnetic waves used for wireless communication with a tag main body 54 (described later) that is overlaid on the sheet member 10. The attachment layer 11 is a layer that is glutinous or adhesive and that includes an attachment member for attaching the sheet member 10 to an article. The attachment member includes at least one of a glue and an adhesive, and has a bond strength based on glutinosity or adhesion property. The attachment layer 11 is not essential, and may be omitted. Any configuration may be applied, as long as the constituent elements can be formed into one piece.

[0059] Electromagnetic waves that are targeted by the sheet member 10 for suitably performing wireless communication via an antenna element are determined according to the application, but examples thereof include electromagnetic waves at a frequency contained in a high MHz band, more specifically, electromagnetic waves at a frequency in the range of 950 MHz or higher and 956 MHz or lower in Japan. The frequency of the target electromagnetic waves is shown as an example, and the invention also encompasses the configuration in which electromagnetic waves at frequencies other than the frequency shown in the example are targeted.

[0060] Furthermore, the sheet member 10 may be used for suitably performing wireless communication using electromagnetic waves at a frequency in a 2.4 GHz band. The 2.4 GHz band has the frequency range of 2400 MHz or higher and lower than 2500 MHz. The electromagnetic waves used in the RFID system are included in the range of 2400 MHz or higher and 2483.5 MHz or lower.

[0061] There is no specific limitation on the frequency of the target electromagnetic waves, but the frequency is in the range of 300 MHz or higher and 300 GHz or lower, and any single or multiple frequencies can be selected. The range of 300 MHz or higher and 300 GHz or lower includes a UHF band (300 MHz to 3 GHz), an SHF band (3 GHz to 30 GHz), and an EHF band (30 GHz to 300 GHz).

[0062] There is no specific limitation on the thickness of the layers 11 to 15 and the total thickness of the sheet member 10. However, for example, in this embodiment, the thickness of the pattern layer 15 is 100 Å (1×10^{-8} m) or more and 500 μm or less, the thickness of the first storage layer 14 is 1 μm or more and 5 mm or less, the thickness of the second storage layer 13 is 1 μm or more and 45 mm or less, the thickness of the reflection area forming layer 12 is 100 Å (1×10^{-8} m) or more and 500 μm or less, the thickness of the attachment layer 11 is 1 μm or more and 1 mm or less, and the total thickness of the sheet member 10 is 3 μm or more and 50 mm or less. The sheet member 10 is formed into a sheet in which the mass per unit area is 0.1 kg/m² or more and 40 kg/m² or less. The total thickness of the sheet member 10 is small as described above, and the layers 13 to 16 are made of the above-described materials and are flexible. Accordingly, the shape of the sheet member 10 can be freely changed.

[0063] When used for wireless communication in a high MHz band, the total thickness of the sheet member 10 is set to 0.1 mm or more and 15 mm or less, and when used for wireless communication in a 2.4 GHz band, the total thickness of the sheet member 10 is set to 0.1 mm or more and 8 mm or less. With this sort of configuration, the thickness of the sheet member 10 for enabling wireless communication to be suitably performed using electromagnetic waves at a frequency contained in a high MHz band or 2.4 GHz band can be made as small as possible, and thus the sheet member 10 can be made thinner.

[0064] In this embodiment, material property values including the complex relative magnetic permeability μ and the complex relative dielectric constant ϵ of the first storage layer 14 are selected, so that electromagnetic waves used for wireless communication are selected. As the real number part μ' of the complex relative magnetic permeability is larger, lines of magnetic force are allowed to more concentratedly pass through, and the propagation path of electromagnetic waves can be bent. As the imaginary number part μ'' of the complex relative magnetic permeability and a magnetic permeability loss term $\tan \delta \mu$ ($= \mu''/\mu'$) are smaller, the loss of magnetic field energy becomes smaller. Accordingly, the real number part μ' of the complex relative magnetic permeability is preferably larger, and the imaginary number part μ'' of the complex relative magnetic permeability and the magnetic permeability loss term $\tan \delta \mu$ are preferably smaller. With a wavelength shortening effect obtained from the magnetic material, the size of the conductive pattern portions and the distance between the pattern layer and the reflection area forming layer are shortened. With a wavelength shortening effect obtained from the dielectric, and the path of electromagnetic waves along the pattern, the distance corresponding to $\lambda/4$ (approximately 3 cm, in the case of a 2.4 GHz) is shortened to approximately 1 mm to approximately 8 mm (in the case of a 2.4 GHz band). This case is substantially the same as the case of $\lambda/4$ in a space, and can be included in $\lambda/4$ in the invention. Furthermore, as the real number part ϵ' of the complex relative dielectric constant is larger, lines of electric force are allowed to more concentratedly pass through, and the propagation path of electromagnetic waves can be bent. As the imaginary number part ϵ'' of the complex relative dielectric constant is smaller, the loss of electric field energy becomes smaller. Accordingly, the real number part ϵ' of the complex relative dielectric constant is

preferably larger, and the imaginary number part ϵ'' of the complex relative dielectric constant is preferably smaller. The storage layers are not intended to lose energy, but intended to concentratedly collect energy and allow the energy to pass through without being lost. The sheet member 10 of the invention is different from electromagnetic wave absorbing members in that the loss in the storage layers is preferably smaller.

5 **[0065]** Furthermore, in the invention, the values of the real number part μ' and the imaginary number part μ'' of the complex relative magnetic permeability and the real number part ϵ' and the imaginary number part ϵ'' of the complex relative dielectric constant are values corresponding to the frequency of electromagnetic waves used for wireless communication. As described above, the frequency of electromagnetic waves used for wireless communication may be in the range of 300 MHz or higher and 300 GHz or lower including a UHF band, an SHF band, and an EHF band, and may be in a high MHz band or 2.4 GHz band, for example.

10 **[0066]** Fig. 2 is an enlarged cross-sectional view showing the internal structure of the first storage layer 14. In Fig. 2, for facilitating understanding, hatching of magnetic powders 18 and magnetic fine particles 19 is omitted. In order to obtain the above-described material property values, in the first storage layer 14, powders made of a magnetic material (hereinafter, referred to as 'magnetic powders') 18 and fine particles made of a magnetic material (hereinafter, referred to as 'magnetic fine particles') 19 are mixed in a binder 17. The first storage layer 14 contains the magnetic powders 18 and the magnetic fine particles 19 as magnetic materials. Fig. 2 is shown as an example, and there is no limitation to this. In this embodiment, the binder 17 is made of a polymer, for example, a non-halogen-based polymer, or a non-halogen-based mixture in which a non-halogen-based polymer and another polymer or the like are mixed.

15 **[0067]** As the binder 17, a halogen-based polymer also can be used. The binder 17 may be made of a material having any material quality, such as a polymer (resin, TPE, rubber) gel, an oligomer, or the like. The material may be either organic or inorganic, and the degree of polymerization or the like of the material does not matter. A non-halogen-based material can be preferably used in view of the environment. In order to form the binder 17 into a sheet, a polymer material is suitable. For example, materials shown below can be preferably used, but materials, blended materials, alloy materials, and the like not shown below also can be used, as long as the material can be formed into a sheet.

20 **[0068]** As the material of the binder 20, various organic polymer materials can be used, and examples thereof include polymer materials such as rubbers, thermoplastic elastomers, and various plastics. Examples of the rubbers include natural rubbers, as well as synthetic rubbers (used alone) such as a isoprene rubber, a butadiene rubber, a styrene-butadiene rubber, an ethylene-propylene rubber, an ethylene-vinyl acetate-based rubber, a butyl rubber, a chloroprene rubber, a nitrile rubber, an acrylic rubber, an ethylene acrylic rubber, an epichlorohydrin rubber, a fluorine rubber, a urethane rubber, a silicone rubber, a chlorinated polyethylene rubber, and a hydrogenated nitrile rubber (HNBR), derivatives thereof, and rubbers obtained by modifying these rubbers with various types of modification treatment.

25 **[0069]** These rubbers may be used alone or in combination of a plurality of types. Agents that have been conventionally added to rubbers, such as vulcanizing agents, vulcanization promoters, antioxidants, softeners, plasticizers, fillers, colorants, and the like can be added to these rubbers. In addition to the above, any additive also can be used. For example, in order to control dielectric constant and electrical conductivity, a predetermined amount of dielectric (carbon black, graphite, titanium oxide, etc.) may be added as a material design. Moreover, processing aids (lubricant, dispersant) also may be selectively added as appropriate.

30 **[0070]** Examples of the thermoplastic elastomers include chlorine-based (e.g., chlorinated polyethylene-based), ethylene copolymer-based, acrylic, ethylene acrylic copolymer-based, urethane-based, ester-based, silicone-based, styrene-based, amide-based, and other various thermoplastic elastomers, and derivatives thereof.

35 **[0071]** Examples of various plastics include polyethylene, polypropylene, AS resins, ABS resins, polystyrene, chlorine-based resins such as polyvinyl chloride and polyvinylidene chloride, polyvinyl acetate, ethylene-vinyl acetate copolymers, fluorine resins, silicone resins, acrylic resins, nylon, polycarbonate, polyethylene terephthalate, alkyd resins, unsaturated polyester, polysulfone, polyphenylene sulfide resins, liquid crystal polymers, polyamide imide resins, urethane resins, phenol resins, urea resins, epoxy resins, polyimide resins, and other thermoplastic resins or thermosetting resins, and derivatives thereof. As a binder thereof, low-molecular weight oligomer type-binders and liquid type-binders can be used. Any material can be selected, as long as the material can be formed into a sheet with heat, pressure, ultraviolet rays, a curing agent, or the like after molding. In addition to the above, any organic or inorganic material such as ceramics, paper, clay, and the like can be used.

40 **[0072]** The magnetic powders 18 are flat soft magnetic metal powders. The powders are dispersed so as not to be brought into contact with each other, and arranged so as to extend perpendicularly to the thickness direction of the first storage layer 14. The magnetic powders 18 are substantially in the shape of a disk in which the average thickness is 2 μm , and the average outer diameter in a direction perpendicular to the thickness direction is 55 μm . The magnetic fine particles 19 are fine particles in which the thickness and size are smaller than those of the metal powders. At least the entire outer surface portion of the magnetic fine particles are not conductive, and the electrical conductivity of the magnetic fine particles is low. The average outer diameter of the magnetic fine particles 19 is 1 μm .

45 **[0073]** As the binder 17 constituting the first storage layer 14, for example, HNBR, which is hydrogenated NBR rubber, is used. The magnetic powders 18 are made of, for example, sendust, which is an alloy of iron, silicon, and aluminum

(Fe-Si-Al). Furthermore, the magnetic fine particles are made of, for example, iron oxide (magnetite) that overall suppresses electrical conductivity and has corrosion resistance. The size and the material are shown as an example, and there is no limitation to this.

[0074] There is no specific limitation on the material configuration of the first storage layer 14, as long as the complex relative magnetic permeability and the complex relative dielectric constant are appropriate. The binder 17 in which the soft magnetic powders 18 and/or the magnetic fine particles 19 are dispersed as in this example, or magnetic materials (metal oxide, ceramics, granular thin film, ferrite plating, etc.) without any treatment may be used as the first storage layer 14. Examples of soft magnetic powders used as the soft magnetic powders 18 and/or the magnetic fine particles 19 include sendust (Fe-Si-Al alloy), permalloy (Fe-Ni alloy), silicon steel (Fe-Cu-Si alloy), Fe-Si alloy, Fe-Si-B (-Cu-Nb) alloy, Fe-Ni-Cr-Si alloy, Fe-Cr-Si alloy, Fe-Al-Ni-Cr alloy, Fe-Ni-Cr alloy, Fe-Cr-al-Si alloy, and the like. Furthermore, ferrite or pure iron particles also may be used. Examples of the ferrite include soft ferrite such as Mn-Zn ferrite, Ni-Zn ferrite, Mn-Mg ferrite, Mn ferrite, Cu-Zn ferrite, and Cu-Mg-Zn ferrite, and hard ferrite that is a permanent magnet material. Examples of the pure iron particles include carbonyliron and the like. Preferably, flat soft magnetic powders having high magnetic permeability are used. These magnetic materials may be used alone or in combination of a plurality of types. As the soft magnetic powders, flat soft magnetic powders and non-flat soft magnetic powders (e.g., needle shaped, fibrous, spherical, or block-shaped powders) may be combined, but at least one of the powders in this combination is preferably flat. The particle size of the soft magnetic powders is 0.1 μm or more and 1000 μm or less, preferably 10 μm or more and 300 μm or less. The aspect ratio of the flat soft magnetic powders is 2 or more and 500 or less, preferably 10 or more and 100 or less. In order to improve corrosion resistance, the surface of the soft magnetic powders may have an oxide film. The surface of the magnetic powders is preferably subjected to surface treatment. The surface treatment may follow a commonly used treatment method in which a coupling agent, a surfactant, or the like is used as the surface treatment agent. Any means (resin coating, dispersant, etc.) can be used in order to improve the wettability between the magnetic powders and the binder.

[0075] The first storage layer 14 is made of, or contains, at least one of soft magnetic metal, soft magnetic metal oxide, magnetic metal, and magnetic metal oxide, as the magnetic member. The first storage layer 14 may have the configuration in which at least one of powders and fine particles made of at least one of soft magnetic metal, soft magnetic metal oxide, magnetic metal, and magnetic metal oxide is disposed in the binder 17 as described above, or may be formed into a film including a thin film made of at least one of soft magnetic metal, soft magnetic metal oxide, magnetic metal, and magnetic metal oxide. As the first storage layer 14, for example, magnetic ceramics (ferrite, etc.) may be used without any treatment.

[0076] The first storage layer 14 having the configuration in which the magnetic material is dispersed in the binder 17 is made of a material in which one or a plurality of materials selected from the group consisting of ferrite, iron alloy, and iron particles are contained as the magnetic material in an amount blended of 1 part by weight or more and 1500 parts by weight or less, with respect to 100 parts by weight of an organic polymer as the binder 17. The amount of the magnetic material blended with respect to 100 parts by weight of the organic polymer is preferably 10 parts by weight or more and 1000 parts by weight or less. In a case where the amount of the magnetic material blended with respect to 100 parts by weight of the organic polymer is less than 1 part by weight, sufficient magnetic permeability cannot be obtained. In a case where the amount blended is more than 1500 parts by weight, processability becomes poor, and thus the sheet member 10 cannot be produced, or the production become difficult.

[0077] In a case where the configuration of the first storage layer 14 is the same, the real number part μ' and the imaginary number part μ'' of the complex relative magnetic permeability vary depending on the frequency of target electromagnetic waves, and tend to be smaller as the frequency of target electromagnetic waves becomes higher. In this embodiment, the target electromagnetic waves include electromagnetic waves in a high MHz band and 2.4 GHz band. The real number part μ' and the imaginary number part μ'' of the complex relative magnetic permeability tend to be smaller as the frequency of target electromagnetic waves becomes higher. Accordingly, in order to allow electromagnetic waves including electromagnetic waves in a high MHz band and 2.4 GHz band to be collected and pass through, the real number part μ' and the imaginary number part μ'' of the complex relative magnetic permeability, in particular, the real number part μ' overall becomes smaller compared with those in the configuration for allowing, for example, electromagnetic waves at low frequency in an approximately 1 to 10 MHz band to be collected and pass through.

[0078] In order to increase the real number part μ' of the complex relative magnetic permeability in the first storage layer 14, it is necessary to increase the amount of portion made of a magnetic material in the first storage layer 14. Furthermore, in order to reduce the imaginary number part μ'' of the complex relative magnetic permeability, it is possible to reduce the amount of portion made of a non-magnetic material in paths 20 of lines of magnetic force. When the amount of the magnetic powders 18 blended in the first storage layer 14 is simply increased, the amount of portion made of a magnetic material becomes larger, and thus the amount of portion made of a non-magnetic material in the paths of lines of magnetic force can be made smaller. However, in a case where the amount of the magnetic powders 18 blended is increased so significantly that, for example, the conductive magnetic powders 18 are brought into contact with each other, the first storage layer 14 becomes conductive, and a current flows in the first storage layer 14. As a result,

conduction is established between the conductive pattern portions and the reflection area forming layer, and thus the performance as an antenna that receives electromagnetic waves is impaired. Accordingly, it is not possible to simply increase the amount of the magnetic powders 18 blended.

[0079] In this embodiment, the magnetic fine particles 19 are mixed together with the magnetic powders 18, and thus the magnetic powders 18 are prevented from being brought into contact with each other. Furthermore, since the magnetic fine particles 19 are interposed between the magnetic powders 18, the amount of portion made of a magnetic material can be increased, and the amount of portion made of a non-magnetic material in the paths 25 of lines of magnetic force can be reduced. Accordingly, the above-described complex relative magnetic permeability μ can be obtained for electromagnetic waves in a high MHz band and 2.4 GHz band.

[0080] As the first storage layer 14 in another embodiment of the invention, in order to increase the ratio of the magnetic material filled, two types of differently-sized magnetic particles having an average particle size ratio of approximately 4:1 are mixed in the above-described binder 17, and the magnetic fine particles and soft magnetic metal fiber are mixed. Furthermore, in order to secure electric insulation, electrically insulating fine particles are mixed. The two types of magnetic particles are made of the same material as that of the magnetic powders 18, the average particle size of the larger particles is approximately 20 μm , and the average particle size of the smaller particles is approximately 5 μm . The magnetic fine particles and the soft magnetic metal fiber are made of iron-based materials, and the average particle size of the magnetic fine particles and the average fiber size of the soft magnetic metal fiber is approximately 1 μm . The electrically insulating fine particles are made of silicon oxide (SiO_2), and has an average particle size of approximately 10 nm. Furthermore, in order to reduce voids in the first storage layer 14 to the extent possible, the first storage layer 14 is designed and produced so that the measured specific gravity value is close to the theoretical specific gravity value based on the blend to the extent possible. Also when applying the above-described configuration instead of the configuration shown in Fig. 2, the resonance frequency at which the imaginary number part μ'' of the complex relative magnetic permeability has a peak value is shifted toward the high frequency side. When the frequency is further increased to 5 GHz and to 10 GHz, the first storage layer 14 can be realized in which the real number part μ' of the complex relative magnetic permeability is large at 300 MHz or higher, in particular, in a high MHz band and 2.4 GHz band, and the imaginary number part μ'' of the complex relative magnetic permeability is not too large.

[0081] The second storage layer 13 can be made of the same material as that of the first storage layer 14. According to the application, materials such as vinyl chloride resins, melamine resins, polyester resins, urethane resins, wood, plaster, cement, ceramics, nonwoven fabric, foam resins, foams, heat insulating materials, paper including flame retardant paper, glass fabrics, and the like can be used, as long as the material is a non-conductive dielectric material. It will be appreciated that dielectric members or magnetic members can be blended as appropriate. The real part ϵ' of the complex relative dielectric constant of the second storage layer 13 is selected to be in the range of 1 or more and 50 or less. With this sort of configuration, the dielectric constant of the second storage layer 13 and the sheet member 10 can be freely controlled, and a contribution can be made to realization of smaller conductive pattern portions 22 and a thinner sheet member 10.

[0082] At least one surface portion of the sheet member 10 is glutinous or adhesive. In this embodiment, the attachment layer 11 is disposed as described above, and thus the surface portion on the other side in the thickness direction is glutinous or adhesive. With the bond strength due to the glutinosity or adhesion property of the attachment layer 11, the sheet member 10 can be attached to an article. Accordingly, the sheet member 10 can be attached, for example, to a communication jamming member 12, and thus the sheet member 10 can be easily disposed between an antenna element 51 and the communication jamming member 12. The sheet member 10 is disposed so that one side in the thickness direction is disposed on the side of the antenna element 51 and the other side in the thickness direction is disposed on the side of the communication jamming member 57. As the attachment member realizing the attachment layer 11, for example, No. 5000NS (manufactured by Nitto Denko Corporation) is used.

[0083] The reflection area forming layer 12 may be metals such as gold, platinum, silver, nickel, chromium, aluminum, copper, zinc, lead, tungsten, iron, or the like, a resin mixture in which powder of the above-mentioned metal or conductive carbon black is mixed in a resin, known conductive ink, or films made of a conductive resin. The above-mentioned metal or the like formed into a plate, a sheet, a film, a nonwoven fabric, a cloth, or the like also can be used. Conductive oxides such as ITO and ZnO also can be used. The configuration also can be applied in which metal foil and glass fabrics are combined. The configuration also can be applied in which a metal layer having a film thickness of, for example, 600 Å is formed on a synthetic resin film. The configuration also can be applied in which conductive ink (electrical conductivity is 5,000S/m or more) is applied onto a substrate. It is also possible to apply a configuration having mesh or other patterns reflecting electromagnetic waves at a specific frequency.

[0084] Using the above-described material constituting the reflection area forming layer 12, the conductive pattern portions 22 of the pattern layer 15 can be formed. Each of the conductive pattern portions 22 is made of, for example, a metal such as silver, aluminum, or the like, and has an electrical conductivity of 5,000S/m or more. A plate-shaped base 31 is made of, for example, polyethylene terephthalate, and the above-described metal is evaporated thereon, so that the conductive pattern portions 22 are formed. The storage layers 14 and 13 are arranged in the vicinity of the

conductive pattern portions 22.

[0085] The size of the conductive pattern portions 22 is optimized according to the frequency of the target electromagnetic waves, and the size is determined to be the above-described size. Accordingly, the size is shown as an example, and is determined as appropriate based on the frequency of the target electromagnetic waves. Furthermore, the gap between the conductive pattern portions 22 is determined based on the frequency of the target electromagnetic waves so that the receiving efficiency becomes high. The properties of the storage layer, more specifically, the complex relative dielectric constant or the complex relative magnetic permeability based on the material quality, the thickness, and the like are determined based on the frequency of the target electromagnetic waves so that the receiving efficiency becomes high. In this manner, the size and the gap size of the conductive pattern portions 22 are determined, the storage layers are configured, and electromagnetic waves can be efficiently received.

[0086] As another embodiment of the invention, for example, a flame retardant or an auxiliary flame retardant is added to at least one of the pattern layer 15 and the storage layers, and thus the sheet member 10 is flame-resistant, semi-incombustible, or incombustible. For example, a flame retardant or an auxiliary flame retardant is added to the pattern layer 15 or the storage layers. Thus, the sheet member 10 is flame-resistant. Furthermore, at least part of the outer periphery of the sheet member 10 may be covered by a material that is flame-resistant or incombustible. For example, also in the case of electronics apparatuses such as portable telephones, the internal polymer material may be required to be flame-resistant.

[0087] There is no specific limitation on the flame retardant for obtaining such flame resistance, but, for example, phosphorus compounds, boron compounds, bromine-based flame retardants, zinc-based flame retardants, nitrogen-based flame retardants, hydroxide-based flame retardants, metal compound-based flame retardants or the like can be used as appropriate. Examples of the phosphorus compounds include phosphoric acid ester and titanium phosphate. Examples of the boron compounds include zinc borate. Examples of the bromine-based flame retardants include hexabromobenzene, hexabromocyclododecane, decabromobenzylphenylether, decabromobenzylphenyl oxide, tetrabromobisphenol, and ammonium bromide. Examples of the zinc-based flame retardants include zinc carbonate, zinc oxide, and zinc borate. Examples of the nitrogen-based flame retardants include triazine compounds, hindered amine compounds, and melamine-based compounds such as melamine cyanurate and melamine guanidine compounds. Examples of the hydroxide-based flame retardants include magnesium hydroxide and aluminum hydroxide. Examples of the metal compound-based flame retardants include antimony trioxide, molybdenum oxide, manganese oxide, chromium oxide, and iron oxide.

[0088] In this embodiment, taking the content of the binder as 100 in the weight ratio, when 20 of bromine-based flame retardant, 10 of antimony trioxide, and 14 of phosphoric acid ester are added, the flame resistance corresponding to v0 in UL94 nonflammability test can be obtained. The sheet member 10 preferably can be a material constituting an article, or can be attached to an article. For example, the sheet member 10 can be preferably used, for example, in a state where the sheet member 10 is attached to an article used in a space in which combustion or gas generation resulting from combustion are desired to be prevented, such as apparatuses inside aircrafts, watercrafts, and vehicles.

[0089] The sheet member 10 is electrically insulating. Specifically, in a case where each of the layers 14 and 13 is made of the above-described material, the surface resistivity (JIS K6911) of the sheet member 10 is $10^2 \Omega/\square$ or more. The surface resistivity of the storage layers is preferably larger. Accordingly, the possible maximum value is the upper limit value of the surface resistivity. In this manner, the sheet member 10 has high surface resistivity, and is electrically insulating.

[0090] Furthermore, the sheet member 10 is heat-resistant. Specifically, the sheet member 10 can resist a temperature up to 150°C in a case where a crosslinking agent is added to a rubber or resin material. The properties of the sheet member 10 do not change at least to a temperature exceeding 150°C. Regarding heat resistance, resistance against a temperature of 150°C or higher can be provided also by coating at least part of a tag 54, the sheet member 10, the antenna element, and an IC chip with ceramics or a heat resisting resin (for example, a polyphenylene sulfide resin to which SiO₂ fillers have been added). In the case of ceramics coating, complete sintering or partial sintering may be performed, or sintering may not be performed.

[0091] In another embodiment of the invention, the configuration also may be applied in which the sheet member 10 in the embodiment shown in Fig. 1 does not include the reflection area forming layer 12. Even in the configuration in which the reflection area forming layer 12 is not included, a similar effect can be obtained by arranging the sheet member 10 on a face of an object that has a portion made of a conductive material. In the configuration in which the reflection area forming layer 12 is used, the influence of the arrangement position of the sheet member 10, that is, the type or the like of materials constituting a communication jamming member can be prevented from changing the resonance frequency of the conductive pattern portions 22 and changing the receiving properties of the sheet member 10. Thus, the communication conditions using the antenna element 51 can be prevented from being changed, and the communication conditions using the antenna element 51 can be stabilized. For example, even when the sheet member 10 is disposed inside interior materials of buildings, the receivable frequency can be prevented from being changed by the influence of the complex relative dielectric constant or the like of the interior materials.

[0092] As the conductive pattern portions used in the invention, conductive pattern portions may be non-continuously arranged, or slots (holes) may be formed in a conductive layer. There is no limitation on the shape of the pattern portions. Any shape can be applied such as a single or a plurality of circles, rectangles, lines, polygons, strings, irregular shapes, or a combination thereof, as long as the shape can realize the function as an antenna.

5 **[0093]** Fig. 3 is a front view showing the pattern layer 15 constituting the sheet member 10 according to an embodiment of the invention. Figs. 4 and 5 are enlarged front views of part of the pattern layer 15 in the embodiment shown in Fig. 3. In the pattern layer 15, the conductive pattern portions 22 are formed on the surface of the plate-shaped base 21 on the electromagnetic wave incident side. The plate-shaped base 21 is, for example, a dielectric made of a synthetic resin, and the plate-shaped base 21 also functions as a dielectric member. The conductive pattern portions 22 have radial pattern portions 30 and rectangular pattern portions 31. The plate-shaped base 21 electrically insulates the conductive pattern portions 22 from each other. In Figs. 3, 4, and 5, for facilitating understanding, the conductive pattern portions 22 are hatched with diagonal lines.

10 **[0094]** The radial pattern portion 30 is formed into a radial shape, and a plurality of radial pattern shapes 30a are spaced away from each other by gaps (hereinafter, referred to as 'radial pattern gaps') c2x and c2y. More specifically, for example, in this embodiment, the radial pattern shapes 30a are formed in the shape of crosses radially extending in the x direction and the y direction that are perpendicular to each other, and regularly arranged in a matrix in which the radial pattern gap c2x is interposed in the x direction and the radial pattern gap c2y is interposed in the y direction.

15 **[0095]** The radial pattern shape 30a has a shape in which four corners 41 in an intersecting portion 36 are formed into curves, more specifically, arcs, based on a cross 40 indicated by the virtual line in Fig. 5. The cross 40 functioning as the base (hereinafter, referred to as a base cross) has a shape in which a rectangular shape portion 34 linearly extending in the x direction and a rectangular shape portion 35 linearly extending in the y direction intersect each other at right angles at the intersecting portion 36 so that the centroids of the shape portions 34 and 35 are overlapped. The shape portions 34 and 35 are displaced from each other by 90° about an axis perpendicular to the intersecting portion 36, and have the same shape. Four substantially triangular portions 42, that are right-angled isosceles triangles in which the oblique side opposing the right-angled corner is in the shape of an arc recessed toward the right-angled corner, are arranged on this base cross 40 so that the right-angled corners are accommodated in the respective corners 41 of the intersecting portion 36 in the base cross 40.

20 **[0096]** In a case where the frequency of the target electromagnetic waves is in a 2.4 GHz band, for example, the radial pattern shape 30a has a size in which widths a1x and a1y of the shape portions 34 and 35 are the same, for example, 1.0 mm, and lengths a2x and a2y of the shape portions 34 and 35 are the same, for example, 25.0 mm. The sizes of the arc at the arc-shaped corner, that is, the lengths of the sides excluding the oblique side of the substantially triangular portion 42, more specifically, a length a3x, of the side in the x direction and a length a3y of the side in the y direction are the same, for example, 11.5 mm, and the radius of curvature R1 of the oblique side is 11.5 mm. Regarding the radial pattern gaps, the gap c2x in the x direction and the gap c2y in the y direction are the same, for example, 4.0 mm.

25 **[0097]** A rectangular pattern shape 31a is disposed in a region enclosed by the radial pattern shapes 30a so as to be spaced away from the radial pattern shapes 30a by a gap (hereinafter, referred to as a 'radial-rectangular portion gap') c1 so that the rectangular pattern shape 31a covers the region enclosed by the radial pattern shapes 30a. More specifically, the rectangular pattern shapes 31a are formed into a shape corresponding to the region enclosed by the radial pattern portions. More specifically, for example, in this embodiment, the radial pattern portion 30 is in the shape of a cross as described above, and the region enclosed by the radial pattern shapes 30a is substantially in the shape of a rectangle based on a rectangle. The shape corresponding thereto, that is, the radial-rectangular portion gap c1 has the same shape throughout the entire periphery. In a case where the shape portions 34 and 35 have the same shape as described above, the region enclosed by the radial pattern shapes 30a is substantially in the shape of a square based on a square, and the rectangular pattern shapes 31a are substantially in the shape of a square based on a square 25. The rectangular pattern shapes 31a are arranged so that the side portions of the square functioning as the base (hereinafter, referred to as a base square) 25 extend in either the x direction or the y direction.

30 **[0098]** The rectangular pattern shapes 31a are substantially in the shape of a rectangle in which four corners 26 are formed into curves, more specifically, arcs, based on the base square 25. More specifically, four substantially triangular portions 27, that are right-angled isosceles triangles in which the oblique side opposing the right-angled corner is in the shape of an arc recessed toward the right-angled corner, are removed from the base square 25 so that the right-angled corners are accommodated in the respective corners 26 of the square.

35 **[0099]** In a case where the frequency of the target electromagnetic waves is in a 2.4 GHz band, for example, the rectangular pattern shape 31a has a size in which a size b1x in the x direction and a size b1y in the y direction of the base square 25 are the same, for example, 25.0 mm. The sizes of the arc at the arc-shaped corner, that is, the lengths of the sides excluding the oblique side of the substantially triangular portion 27, more specifically, a length b2x of the side in the x direction and a length b2y of the side in the y direction are the same, for example, 10.0 mm, and the radius of curvature R2 of the corners is 10.0 mm. Regarding the radial-rectangular portion gap, a gap c1x in the x direction and a gap c1y in the y direction are the same, for example, 4.0 mm.

[0100] In this manner, the radial pattern shapes 30a and the rectangular pattern shapes 31a are conductive pattern portions substantially based on polygons, having a substantially polygonal outer shape in which at least one corner is curved. In this sort of pattern, a resonance current when receiving electromagnetic waves smoothly flows at the curved corners.

5 **[0101]** Furthermore, the radial pattern shapes 30a and the rectangular pattern shapes 31a are not in the shape of a strip (belt) forming a closed loop extending along the outer peripheral edge of the shapes, but are a planar pattern in which the inner portion is also covered. Accordingly, a capacitor can be formed between the pattern layer 15 and the reflection area forming layer 12.

10 **[0102]** With this sheet member 10, the pattern layer 15 makes it possible for electromagnetic waves at the resonance frequency of the conductive pattern portions 22 to be efficiently received. The resonance frequency of the sheet member 10 is first specified according to the length and the peripheral length of the conductive pattern portions 22. Since electromagnetic waves are received so as to be resonated with electromagnetic waves at a specific frequency, the resonance length is determined according to, for example, the length of 1/2 or 1/4 of the wavelength of the electromagnetic waves at the specific frequency. Here, the final resonance frequency is determined not only according to the pattern size but, 15 also according to the binding properties between the conductive pattern portions 22, a wavelength shortening effect resulting from the real part ϵ' of the complex relative dielectric constant or the real part μ' of the complex relative magnetic permeability of the first and the second storage layers 14 and 13, and a wavelength shortening effect resulting from the real part ϵ' of the complex relative dielectric constant of the surface layer 16 and the influence of input impedance determined based on the first and the second storage layers 14 and 13 in a case where the surface layer 16 is additionally disposed. This resonance frequency is substantially the same as the frequency used for wireless communication in the antenna element 51 described later.

20 **[0103]** When the sheet member 10 is used according to the size corresponding to the tag main body 54 (described later), at least one of the radial pattern shapes 30a and the substantially rectangular pattern shapes 31a may be contained only partially in the conductive pattern portions 22. In this case, the resonance frequency is shifted toward the high 25 frequency side according to the downsizing of the pattern shape, that is, the partial shape of the radial pattern shapes 30a and the partial shape of the substantially rectangular pattern shapes 31a contained in the conductive pattern portions 22.

30 **[0104]** Fig. 6 is a graph showing a calculation result obtained with a simulation of the resonance frequency that is changed by the influence of cutting of the conductive pattern portions 22. Fig. 7 is a front view showing the pattern shape of the conductive pattern portion 22 of the sheet member 10 used in the simulation. In Fig. 7, the horizontal axis represents the frequency, and the vertical axis represents the reflection loss. The reflection loss refers to the loss from a point of view in which electromagnetic waves that are incident on the sheet member 10 are reflected by the sheet member 10, and has a value corresponding to the amount of electromagnetic waves received in the sheet member 10. The reflection loss is represented by a negative value, and the absolute value of the reflection loss is the amount of electromagnetic waves received. That is to say, the reflection loss functions as an indicator in evaluation of the properties as an antenna. It is indicated that, as the value of the reflection loss is smaller, the efficiency of the sheet member 10 in receiving electromagnetic waves is higher. The reflection loss amount in the invention is calculated using a computer simulation. The simulation follows the TLM method and is performed using a 'Micro-Stripes' manufactured by Flomerics. In the calculation, the material constants of the first storage layer 14, for example, in a 2.4 GHz band were set so that the real part ϵ' of the complex relative dielectric constant = 12.3, the imaginary part ϵ'' of the complex relative dielectric constant = 1.3, the real part μ' of the complex relative magnetic permeability = 1.3, the imaginary part μ'' of the complex relative magnetic permeability = 0.5, and the thickness = 0.5 mm. The material constants of the second storage layer 13, for example, in a 2.4 GHz band were set so that $\epsilon' = 4.6$, $\epsilon'' = 0.1$, and the thickness = 2.0 mm. In the simulation, the correspondence between the frequency and the reflection loss in a state where the sheet member 10 was overlaid on a metal plate was calculated.

45 **[0105]** In the conductive pattern portion 22 on which the pattern layer 15 used in the simulation was based, $a1x = a1y = 1.0$ mm, $a2x = a2y = 17.5$ mm, $a3x = a3y = 7.5$ mm, $c1x = c1y = 1.5$ mm, $c2x = c2y = 7.0$ mm, $b1x = b1y = 20.5$ mm, $c1x = c1y = 1.5$ mm, $R1 = 7.5$, and $R2 = 7.0$ mm. Furthermore, a size L1 in the longer-side direction (the x direction) and a size L2 in the shorter-side direction (the y direction) perpendicular to the overlaid direction of the sheet member 10 were set so that L1 = 80 mm and L2 = 20 mm.

50 **[0106]** Two types of pattern shape formed by cutting part of the conductive pattern portion 22 of the sheet member 10 used in the simulation are respectively taken as a first pattern shape 22A and a second pattern shape 22B, the sheet member 10 in which the first pattern shape 22A is formed is taken as a first sheet member 10A, and the sheet member 10 in which the second pattern shape 22B is formed is taken as a second sheet member 10B.

55 **[0107]** Fig. 7 is a front view of the first sheet member 10A. The first pattern shape 22A includes, among the conductive pattern portions 22, the substantially rectangular pattern shapes 31a and part of the radial pattern shapes 30a in a portion enclosed by a rectangle defined by two sides that pass through the centroids of the radial pattern shapes 30a and that are parallel to the x direction and two sides that pass through the centroids of the radial pattern shapes 30a and that

are parallel to the y direction. The first pattern shape 22A is arranged in a line in the x direction, and includes four substantially rectangular pattern shapes 31a that respectively have centroids arranged at the center in the y direction and part of the radial pattern shapes 30a that are arranged around the substantially rectangular pattern shapes 31a.

5 [0108] In Fig. 6, a solid line 38 represents the frequency reflection loss properties of the first sheet member 10A. The conductive pattern portions 22 of the sheet member 10 are designed so that the frequency at which the reflection loss has a peak value (resonance frequency) corresponds to a 2.4 GHz band, but the resonance frequency of the first sheet member 10A after cutting of the samples is shifted toward the frequency side higher than a 2.4 GHz band. This resonance frequency is the frequency of the sheet member 10 alone before the antenna element 51 is attached.

10 [0109] In Fig. 6, the resonance frequency of the first sheet member 10A does not match a 2.4 GHz band, but the 2.4 GHz band is included in a portion around a resonance peak 38A at which the reflection loss is large, that is, the reflection loss in the 2.4 GHz band is large. Thus, it is seen that the first sheet member 10A has an ability to collect (an ability to collect and supply) electromagnetic waves at a frequency in a 2.4 GHz band. This fact shows that, although the resonance frequency of the sheet member 10 does not completely match the targeted 2.4 GHz band, the sheet member 10 can function as a sending and receiving antenna in which the influence of a metal face and the like is suppressed and a booster antenna that is to supply electromagnetic waves to the antenna element 51, after the resonance frequency is adjusted by reactance matching or the like.

15 [0110] When the antenna element 51 is mounted on the sheet member 10, the resonance frequency may be further shifted, but this problem can be dealt with, by adjusting the distance between the antenna element 51 and the sheet member 10, adjusting the dielectric constant and the magnetic permeability, or adjusting the method for cutting the conductive pattern portions 22 and the size of the antenna element 51. For example, a foam, resin, paper, or the like with an appropriate thickness can be interposed between the antenna element 51 and the sheet member 10, using an adhesive or glue.

20 [0111] When the sheet member 10 has the above-described layer configuration, the receiving efficiency of electromagnetic waves can be increased, and thus a large gain as the function of an antenna can be obtained, and the sheet member 10 can be made thinner and lighter.

25 [0112] Furthermore, in the conductive pattern portion 32, the radial pattern shapes 30a are arranged so that radially extending portions face each other as described above, and the rectangular pattern shapes 31a are formed into a shape corresponding to the region enclosed by the radial pattern shapes 30a. In this arrangement, the receiving efficiency is optimized (increased) by combining the radial pattern portions 30 and the rectangular pattern portions 31 having different receiving principles (the radial patterns function as dipole antennas, and the rectangular patterns function as patch antennas). Accordingly, the sheet member 10 having high receiving efficiency can be realized. Furthermore, the radial pattern shape 30a is radially disposed in the x direction and the y direction, and the side portions of a square on which the rectangular pattern shape 31a is based is disposed so as to extend in the x direction and the y direction. Thus, the receiving efficiency of electromagnetic waves polarized so that the direction of the electric field is in the x direction and the y direction can be increased.

30 [0113] In the sheet member 10, the conductive pattern portions 22 that receive electromagnetic waves have a substantially polygonal outer shape that is basically in the shape of a polygon, and thus a peak value of the gain can be increased compared with a case in which the outer shape of the conductive pattern portions 22 is circular. In this manner, the shape is basically polygonal, and at least one corner is curved. Thus, shift of the frequency at which the gain has a peak according to the direction in which electromagnetic waves are polarized can be suppressed low. Accordingly, excellent, receiving properties can be obtained in which a peak value of the gain is high, and shift of the frequency at which the gain has a peak value according to the direction in which electromagnetic waves are polarized is small.

35 [0114] The sheet member 10 uses the conductive pattern portions 22 of the pattern layer 15 to receive electromagnetic waves at a specific frequency following the resonance principle of an antenna. In other words, in the sheet member 10 of the invention, the conductive pattern portions 22 function to effectively operate also as a receiving antenna. Herein, the specific frequency is a frequency determined according to factors such as the shape and the size of the conductive pattern portions 22. When electromagnetic waves are received by the conductive pattern portions 22, a resonance current flows at the end portions of the conductive pattern portions 22, and an electromagnetic field is generated around the peripheral edge portions of the conductive pattern portions 22. In the sheet member 10, electromagnetic waves at a specific frequency are concentrated at the interior of the sheet member due to resonance.

40 [0115] Furthermore, when the sheet member 10 is used in an overlaid state in which the storage layers are interposed between the pattern layer 15 and the conductive layer, a capacitor or an inductor can be formed between the conductive pattern portions 22 of the pattern layer 15 and the conductive layer. In this embodiment, the conductive layer is the reflection area forming layer 12. In another embodiment in which the reflection area forming layer 12 is not included, the conductive layer is a surface layer of an object made of a conductive material. In a case where the distance between the conductive pattern portions 22 and the conductive layer is reduced, the capacity of the capacitor can be increased. Also, a capacitor can be formed between the conductive pattern portions 22. As a capacitor, electromagnetic energy at a specific frequency can be stored. When a capacitor or the like is used, a function to adjust reactance is provided, and

thus the sheet member 10 can be made thinner. Thus, electromagnetic energy corresponding to a specific frequency can be accumulated in the sheet member 10. Electromagnetic energy is apparently accumulated, but the sheet member 10 actually allows captured electromagnetic energy to continuously pass through. The sheet member 10 plays a role to highly effectively re-radiate electromagnetic waves at a specific frequency at the conductive pattern portions 22 functioning as a high-performance small antenna, to cause the electromagnetic waves to be interfered with incident waves thereby forming a region having high electric field intensity, and to transfer the energy by electromagnetic coupling to the antenna element 51 (described later).

[0116] Fig. 8 is an exploded perspective view showing the tag 50 including the sheet member 10. The tag 50 is one of electronic information transmitting apparatuses that transmit information by wireless communication, and is used, for example, as a transponder of an RFID (Radio Frequency Identification) system used for automatically recognizing a solid matter. The tag 50 includes the antenna element 51, an integrated circuit (hereinafter, referred to as an 'IC') 52 that is electrically connected to the antenna element 51 and that functions as communication means for performing communication using the antenna element 51, and the sheet member 10. In the tag 50, at the time when the antenna element 51 receives a request signal from a reader, the antenna element 51 sends signals indicating information stored in the IC 52. Accordingly, the reader can read information held in the tag 50. For example, the tag 50 is attached to a product, and used for management of products such as prevention of product theft or recognition of inventory status. An antenna device includes the antenna element 51 and the sheet member 10. The tag 50 is an electronic information transmitting apparatus that uses the antenna element 11 to send and receive electromagnetic wave signals, and is a battery-less tag that returns electromagnetic wave, signals using the energy of the received electromagnetic wave signals. The tag 50 may be a battery-less tag, or may be a battery-equipped battery tag.

[0117] The antenna element 51 functioning as antenna means is at least an electric field-type antenna element, is a dipole antenna, a loop antenna, or a monopole antenna, and is realized as a dipole antenna in this embodiment. In another embodiment of the invention, the antenna element 51 may be realized as another antenna. In a case where a dipole antenna and the sheet member 10 are combined, the antenna element 51 can be made smaller. With the level of the real number part μ' of the complex relative magnetic permeability and the real number part ϵ' of the complex relative dielectric constant of the sheet member 10, together with the wavelength shortening effect, the antenna element 51 can be made smaller. The dipole antenna is linear, and may have curve and bent portions. It is sufficient that the total length is $\lambda/2$. For example, in the case of 950 MHz, the length is approximately 15.8 cm. When a wavelength shortening effect obtained from the sheet member 10 is applied to this configuration, a linear element having a size of approximately 3 to 10 cm can be realized. When the element is curved or bent, the size allowing accommodation in a label of 2 to 3 cm can be realized. The element can be made further smaller, and thus the element can be attached to a wide range of targets. Since a monopole antenna supplies electricity between an element on one side of a dipole antenna and a ground plate, the total length of the element can be as small as $\lambda/4$. In the case of a loop antenna, when the circumferential length is close to one wavelength, the structure becomes similar to that in which two half-wavelength dipole antennas are arranged side by side, and thus this loop antenna can be regarded as an electric field-type antenna element. The antenna element of the invention includes an antenna element in which the type is switched between an electric field-type and a magnetic field-type, and an antenna element in which electric field-type and magnetic field-type functions are together provided, as long as the antenna element is not of completely magnetic field-type. Furthermore, the antenna element of the invention also includes an antenna element on which a reactance structure portion is mounted.

[0118] The antenna element 51 is realized as a pattern conductor that is formed on a surface portion of a base 53 (made of polyethylene terephthalate (PET)) on one side in the thickness direction. The IC 52 is disposed, for example, at the center portion of the antenna element 51, and is electrically connected to the antenna element 51. The IC 52 has at least a storage portion and a control portion. Information can be stored in the storage portion, and the control portion can store information in the storage portion or read information from the storage portion. In response to a command indicated by electromagnetic wave signals received by the antenna element 51, the IC 52 stores information in the storage portion or reads information stored in the storage portion, and gives signals indicated by the information to the antenna element 51. The base 53 is in the shape of a rectangular plate, and the antenna element 51 is disposed at the center portion of the base 53 so as to extend in the longer-side direction. The layer thickness of the antenna element 51 and the IC 52 is 1 nm or more and 500 μm or less, and the layer thickness of the base 53 is 0.1 μm or more and 2 mm or less. The configuration without a base also can be applied in which the antenna element 51 is directly printed or formed by treatment on the sheet member 10.

[0119] The antenna element 51, the IC 52, and the base 53 constitute the tag main body 54. The tag main body 54 is packaged so that the tag main body 54 is, for example, mounted on a flexible adhesive tape. The tag main body 54 and the sheet member 10 constitute the tag 50. Fig. 8 is an exploded view of the tag main body 54 and the sheet member 10, but the tag main body 54 is overlaid on the sheet member 10 so that the surface portion having the antenna element 51 opposes one surface of the sheet member 10 (one surface of the pattern layer 15 in this embodiment). The surface of the antenna element 51 is covered by a polyethylene terephthalate insulating film having a thickness of 25 μm , and thus the antenna element 51 is insulated from the conductive pattern portions 22. Although not shown in Fig. 8, a glue

and an adhesive may be used between the tag main body 54 (that may not include the base 53) and the sheet member 10, or one or both of the tag main body 54 and the sheet member 10 may be glutinous or adhesive so that these layers are attached to each other. The sheet member 10 is in the form of a rectangular plate, and is overlaid on tag main body 50 to form the tag 50 in the shape of a rectangular plate.

5 **[0120]** There is no specific limitation on the binding structure between the sheet member 10 and the tag main body 54, but these layers may be bound to each other using a binding agent including a glue and an adhesive. In an area having an intensive electric field formed near the surface of the sheet member 10, the sheet member 10 and the antenna element 51 are overlaid in a non-conduction state, that is, overlaid via an electrically insulating non-conductive layer (that also may be a dielectric layer or magnetic layer). Regarding the distance between the sheet member 10 and the antenna element 51, the optimum position can be determined according to the communication properties of the antenna element 51. In Fig. 8, the configuration, for binding the sheet member 10 and the tag main body 54 is omitted. In the tag 50, the layer of the base 53, the layer of the antenna element 51 and the IC 52, the tag main body adhesive layer, the pattern layer 15, the first storage layer 14, the second storage layer 13, the reflection area forming layer 12, and the attachment layer 11 are overlaid in this order from one side in the thickness direction to the other side.

10 **[0121]** The antenna element 51 can send electromagnetic wave signals in a direction intersecting the direction in which the antenna element 51 extends, and receive electromagnetic wave signals arriving from the direction intersecting the direction in which the antenna element 51 extends. In this embodiment, electromagnetic wave signals can be sent in a sending and receiving direction A that is oriented to the side farther from the sheet member 10 than the antenna element 51, and electromagnetic wave signals arriving from the sending and receiving direction A can be received.

15 **[0122]** In the tag 50, for example, at the time when the antenna element 51 receives an electromagnetic wave signal indicating predetermined information that is to be stored (hereinafter, referred to as 'main information') and information to give a command to store the main information (hereinafter, referred to as 'storage command information') from an information management apparatus that is a reader/writer, an electrical signal indicating the main information and the storage command information is given from the antenna element 51 to the IC 52. In the IC tag 51, the control portion stores the main information in the storage portion based on the storage command information.

20 **[0123]** Furthermore, at the time when the antenna element 51 receives an electromagnetic wave signal indicating information (hereinafter, referred to as 'sending command information') to give a command to send information stored in the storage portion (hereinafter, referred to as 'stored information') from the information management apparatus, an electrical signal indicating the sending command information is given from the antenna element 51 to the IC 52. In IC tag 52, the control portion reads the information stored in the storage portion (stored information), and gives an electrical signal indicating the stored information to the antenna element 51, based on the sending command information. Thus, an electromagnetic wave signal indicating the stored information is sent from the antenna element 51.

25 **[0124]** Fig. 9 is a view showing a state in which the tag 50 is attached to the communication jamming member 57. The tag 50 includes the sheet member 10 so that the tag 50 can be used in the vicinity of the communication jamming member 57, which is a member that jams communication. Examples of conductive material, which is one of communication jamming materials in the invention, include metals, si-based materials, carbon-based materials such as graphite sheet, oxides such as ITO and ZnO, and liquids such as water. The conductive material refers to a material that is conductive to the extent that a high-frequency short circuit may occur between the material and the antenna element. The conductive material refers to a material having conductivity, examples thereof include materials having relatively low resistivity that is 10^{-6} Ωcm or higher and lower than 10^{-1} Ωcm (metals, etc.) and materials having relatively high resistivity that is 10^{-1} Ωcm or higher and 10^6 Ωcm or lower (liquids such as water and seawater, and semiconductors).

30 **[0125]** The sheet member 10 is disposed on the side farther from the sending and receiving direction A than the antenna element 51. The sheet member 10 is used in a state where the sheet member 10 is attached via the attachment layer 11 to the communication jamming member 57. The tag 50 is disposed so that the sheet member 10 is disposed closer to the communication jamming member 57 than the antenna element 51 and the sheet member 10 is interposed between the antenna element 51 and the communication jamming member 57.

35 **[0126]** Fig. 10 is a cross-sectional view showing electromagnetic coupling between the antenna element 51 and the pattern layer 15 and electromagnetic coupling between the pattern layer 15 and the radio wave reflecting layer 12. In Fig. 10, for facilitating understanding, constituent elements other than the antenna element 51, the IC 52, and the sheet member 10 in the configuration of the tag 50 are omitted. In a free space in which the communication jamming member 12 is not present in the vicinity of the antenna element 51, an electric field formed by a potential difference between end portions 51a and 51b of the antenna element 51 spreads throughout the space, a magnetic field is formed by a change in the intensity of this electric field, and an electric field is formed by a change in the intensity of this magnetic field. Using the principle that an electric field and a magnetic field are repeatedly formed in a successive manner, the antenna element 51 can send electromagnetic waves. Furthermore, using the inverse principle, the antenna element 51 can receive electromagnetic waves at the resonance frequency.

40 **[0127]** In Fig. 13, when electromagnetic waves are incident on the tag 50, the conductive pattern portions 22 of the pattern layer 15 function as an antenna. When electromagnetic waves at a specific frequency that is a resonance

frequency determined according to the layers 12 to 15 of the sheet member 10 are incident, resonance occurs, and electromagnetic waves at that frequency are concentrated at the interior of the sheet member 10. The dielectric and magnetic first storage layer 14 is interposed between the pattern layer 15 and the reflection area forming layer 12, and the real number part (μ') of the magnetic permeability of the first storage layer 14 is selected as described above, and thus electromagnetic waves that have entered the sheet member 10 are propagated along the first storage layer 14. Accordingly, jamming of communication of the antenna element 51 can be suppressed as small as possible. In Fig. 13, traveling waves enter the sheet member 10, and then pass only through the first storage layer 14. However, this is merely an example, and an effect of improving communication is obtained with all layers in the sheet member 10.

[0128] When an electromagnetic field is generated around the conductive pattern portions 22, an electromagnetic field is generated also on the side farther from the first storage layer 14 than the pattern layer 15. The antenna element 51 is disposed in the vicinity of the pattern layer 15, and when an electromagnetic field is generated around the conductive pattern portions 22, electromagnetic coupling is formed between the conductive pattern portions 22 and the antenna element 51, and electromagnetic energy is transferred from the conductive pattern portions 22 to the antenna element 51. Since electromagnetic energy at the resonance frequency is supplied from the conductive pattern portions 22 to the antenna element 51, receiving power of the antenna element 51 can be increased compared with a case in which the pattern layer 15 is not included. The tag 50 returns electromagnetic wave signals using the energy of the received electromagnetic wave signals, and thus communication distance can be made longer. This effect of reinforcing electromagnetic waves can be described also based on the distance effect between the conductive pattern portions 22 and the reflection area forming layer 12. The gap between the conductive pattern portions 22 and the reflection area forming layer 12 is ideally $((2n-1)/4)\lambda$ (n is a positive integer), but the distance for obtaining an effect corresponding to interference at $((2n-1)/4)\lambda$ in an air is reduced due to the magnetic permeability and the dielectric constant of the storage layers. Preferably, n is 0.

[0129] Furthermore, the sheet member 10 is designed so that the phase of captured electromagnetic waves is adjusted in the interior of the sheet member, and thus an area having high electric field intensity, at a position away from the reflection area forming layer by an electrical length of $((2n-1)/4)\lambda$ (where the wavelength of electromagnetic waves is taken as λ), is formed at the position of the pattern layer 15. In the invention, a position (a virtual electromagnetic wave reflecting face 201 indicated by the virtual line shown in Figs. 11 and 13 described later) having a composite electric field of 0 (zero) and virtually connecting a point near the center of the conductive pattern portions 22 and the reflection area forming layer is formed. When electromagnetic waves are reflected by the virtual electromagnetic wave reflecting face 201 that forms a reflection area, the electromagnetic waves move around the conductive pattern portions 22 along the distance longer than the straight distance $((2n-1)/4)\lambda$. Using this aspect, a longer electrical length from the pattern layer 15 to the reflection area is obtained, and thus the sheet member 10 is made significantly thinner than $\lambda/4$. Portions in which the electrical length from the pattern layer 15 to the reflection area is $((2n-1)/4)\lambda$, in the invention are denoted by arrows 202 in Fig. 13. Accordingly, the electric field intensity is also increased by interference at the position of the conductive pattern portions. With these reinforcement effects, the sheet member 10 also functions as a booster antenna. Accordingly, wireless communication can be suitably performed even in the vicinity of the communication jamming member 12, and a sufficient communication distance can be secured. When the sheet member 10 includes the conductive pattern portions 22 and independently has an antenna function in this manner, an effect of improving communication of the antenna element 51 can be obtained.

[0130] In a state where there is a potential difference between the end portions 51a and 51b of the antenna element 51, each of the end portions 51a and 51b of the antenna element 51 is charged positively or negatively, and thus electric fields are formed between the end portions 51a and 51b of the antenna element 51 and portions 12a and 12b in the reflection area forming layer 12 respectively opposing the end portions 51a and 51b of the antenna element 51, and a positively or negatively charged state that is opposite to the charge of the end portions 51a and 51b of the antenna element 51 is formed. The IC 52 applies an alternating voltage to the antenna element 51, and the end portions 51a and 51b are charged so that the charge is alternately switched between positive and negative. In a case where the sheet member 10 is disposed between the electric field-type antenna element 51 and the communication jamming member 57, the distance between the antenna element 51 and the communication jamming member 57 can be increased. Thus, the intensity of an electric field that is generated by the end portions 51a and 51b of the antenna element 51 being charged and that is formed between the antenna element 51 and the communication jamming member 57 can be reduced. In this embodiment, the reflection area forming layer 12 is formed in the sheet member 10, and the storage layers are formed between the antenna element 51 and the reflection area forming layer 12. Thus, the electrical length between the antenna element 51 and the reflection area forming layer 12 can be increased, and the degree of an electrical short circuit that is generated by the end portions 51a and 51b of the antenna element 51 being charged and that is formed between the antenna element 51 and the reflection area forming layer 12 becomes smaller.

[0131] The above-described phenomenon is to be generated also between the antenna element 51 and the conductive pattern portions 22. However, since the conductive pattern portions 22 are smaller than the corresponding antenna element 51 and are non-continuously arranged, the influence to lower the impedance of the antenna element is small.

[0132] Accordingly, a high-frequency short circuit between the antenna element 51 and the communication jamming member 57 or the reflection area forming layer 12 is less likely to occur. That is to say, it is possible to suppress a high-frequency current flowing between the antenna element 51 and the communication jamming member 57 or the reflection area forming layer 12 due to a high-frequency short circuit occurring, which is similar to an electrical current flowing when a high-frequency voltage is applied to a capacitor, and thus a decrease in the input impedance of the antenna element 51 is suppressed. Suppression of a decrease in the input impedance has been confirmed based on the fact that the current value of a current that flows in the antenna element 51 becomes small as in a case where the communication jamming member 12 is not present. When the sheet member 10 is used in this manner, a decrease in the input impedance can be suppressed. When the input impedance becomes small, this impedance is deviated from the impedance of the communication means (the IC 52) for performing communication using the antenna element 51, and thus signals cannot be exchanged between the antenna element 51 and the communication means. However, since the sheet member 10 can suppress a decrease in the input impedance of the antenna element 51, wireless communication can be suitably performed even in the vicinity of the communication jamming member 57. In order to suppress a decrease in the input impedance, the conductive pattern portions 22 may have slits, projections and recesses, inclination, lightness and darkness, or the like, so as to resist conduction.

[0133] Fig. 11 is a schematic view showing electromagnetic waves that are incident on the sheet member 10 (referred to as traveling waves) and electromagnetic waves that are reflected by the sheet member 10 (referred to as reflected waves). Fig. 12 is a view illustrating reflection of electromagnetic waves. Fig. 13 is an enlarged schematic view showing a part of the sheet member 10 shown in Fig. 11. In Figs. 11 and 13, for facilitating understanding, constituent elements other than the antenna element 51, the IC 52, and the sheet member 10 in the configuration of the configuration of the tag 50 are omitted. When traveling waves are incident on the pattern layer 15, the traveling waves are received by the conductive pattern portions 22, and thus the energy of the traveling waves are apparently collected at the storage layers. In Fig. 13, the orientations of the electric field formed by the electromagnetic waves inside the sheet member 10 are indicated by the broken lines.

[0134] In the sheet member 10, the storage layers can be made thinner by optimally designing the above-described pattern layer 15, and electromagnetic waves can be efficiently received. Moreover, since the pattern layer 15 in which a plurality of types of conductive pattern portions are formed is used, electromagnetic waves can be efficiently received using the properties of the receiving operation in the conductive pattern portions 22. Since the conductive pattern portions 22 are electrically insulated from each other, the frequency band can be made wider, and electromagnetic waves in a wide band can be efficiently received.

[0135] Since the receiving efficiency of electromagnetic waves in a wide frequency band can be increased in this manner, wide and high performance in receiving electromagnetic waves can be obtained. The sheet member 10 can be made thinner and lighter. Furthermore, the degree of freedom in selecting the material quality of the storage layers is increased so as to provide flexibility. Thus, the sheet member 10 having excellent productivity can be obtained.

[0136] Traveling waves and reflected waves of electromagnetic waves are interfered with each other, and thus stationary waves are formed. Depending on the distance from a reflecting face (reflection area) that is formed by the reflection area forming layer 12 and reflects electromagnetic waves, the electric field and the magnetic field reinforce or weaken each other as shown in Fig. 12. At that time, the phase of the reflected waves (electric field) is shifted from the phase of the traveling waves by 180°. Figs. 12 and 13 show stationary waves. In Fig. 12, the stationary waves of the electric field are indicated by the solid lines, and the stationary waves of the magnetic field are indicated by the broken lines. In Fig. 13, the stationary waves of the electric field are indicated by the broken lines. The mechanism in which the stationary waves are formed is not described, but Figs. 12 and 13 show only the intensity (the same views are obtained also in a case where only the amplitude is shown). At the position that is away from the reflecting face by $((2n-1)/4)\lambda$ (n is a positive integer), the electric field intensity is highest, and the magnetic field intensity becomes 0 (zero). The reflecting face shown in Fig. 12 is equivalent to a face having a composite electric field of 0 (zero), and is equivalent to a metal face.

[0137] On the side farther from the antenna element 51 than the pattern layer 15 and the first and the second storage layers 14 and 13, the above-described virtual electromagnetic wave reflecting face 201 that has the storage layers interposed between this face and the pattern layer 15 and that is spaced away from at least one of the antenna element 51 and the pattern layer 15 at the portion between the conductive pattern portions 22 by an electrical length of $((2n-1)/4)\lambda$ (n is a positive integer) is formed so as to connect the conductive pattern portions 22 and the reflection area forming layer 12. The virtual electromagnetic wave reflecting face 201 is an area in which the intensity of an electric field formed between the center portion of the conductive pattern portions 22 and the reflection area forming layer 12 is 0 (zero). Since the intensity of the electric field is 0 (zero), the virtual electromagnetic wave reflecting face 201 functions as a reflecting plate of electromagnetic waves, and electromagnetic waves that have entered the sheet member 10 from the conductive pattern portions 22 are reflected by the virtual electromagnetic wave reflecting face 201 and return. That is to say, at least one of the antenna element 51 and the pattern layer 15 at the portion between the conductive pattern portions 22 and the virtual electromagnetic wave reflecting face 201 are away from each other by a distance of $((2n-1)/4)$ times of the wavelength of electromagnetic waves that travel through the pattern layer 15 and the storage layers.

The wavelength of electromagnetic waves is shorter than the wavelength in an air due to effects of the pattern layer 15 and the storage layers, and thus the portion from the incident portion of the pattern layer 15 to the virtual electromagnetic wave reflecting face 201 realizes a distance corresponding to $((2n-1)/4)$ times (substantially $\lambda/4$, when $n = 0$) of the wavelength of electromagnetic waves in a thin sheet. Furthermore, the electrical distance from at least one of the antenna element 51 and the pattern layer 15 at the portion between the conductive pattern portions 22 to the virtual electromagnetic wave reflecting face 201 is taken as $((2n-1)/4)\lambda$ (n is a positive integer), and thus a longer distance is obtained using curve of the propagation path of electromagnetic waves due to the real number part ϵ' of the complex relative dielectric constant and/or the real number part μ' of the complex relative magnetic permeability in the sheet member 10. When $n = 0$, the distance (the thickness of the sheet member 10) from the pattern layer 15 to the reflection area forming layer 12 can be made significantly thinner than $\lambda/4$. This sort of technique for making sheets thinner has not been proposed so far.

[0138] Regarding an electric field, when the wavelength of electromagnetic waves is taken as λ , at a position away from the reflecting face of the reflection area forming layer 12 by $n \times (\lambda/2)$ (n is a positive integer), traveling waves are canceled by reflected waves. However, at a position away from the reflection area (the virtual electromagnetic wave reflecting face 201) by an electrical length of $((2n-1)/4)$ times of the wavelength, traveling waves and reflected waves reinforce each other by interference. When the antenna element 51 is disposed at a position where reflected electromagnetic waves and arriving electromagnetic waves reinforce each other for interference, wireless communication can be suitably performed even in the vicinity of the communication jamming member 57.

[0139] Fig. 14 is an enlarged perspective view showing a part of the tag 50, in which a part of the tag main body 54 overlaid on the sheet member 10 is cut out. Fig. 15 is a view showing the electric field intensity obtained by a simulation performed in a region indicated by a virtual line 48 shown in Fig. 14. In Fig. 15, the electric field intensity is indicated with a gray scale where an electric field is intensive in a white portion and is less intensive as the color is changed from white toward black. Based on the simulation result, an area having an intensive electric field is observed at the rectangular pattern shapes 31a. In Fig. 15, the electric field vector used for the calculation is horizontal, and the magnetic field vector is vertical. A portion on the right side of the rectangular pattern shapes 31a in Fig. 15 has a black area in which the electric field is 0 (zero). This area corresponds to the above-described virtual electromagnetic wave reflecting face 201.

[0140] Furthermore, the conductive pattern portions 22 that receive electromagnetic waves have a substantially polygonal outer shape that is basically in the shape of a polygon, and thus a peak value of the gain can be increased compared with a case in which the outer shape of the conductive pattern portions 22 is circular.

[0141] The reason for this is that, in the case of a polygonal pattern, the Q value is higher than that of a circular pattern. First, the Q value will be described. The Q value of resonance can be indicated by a band width. The correspondence is $Q = \text{resonance frequency} / \text{band width}$. Accordingly, a high Q value indicates that the band width is narrow.

[0142] This correspondence can be applied for a peak value of the gain using the pattern. That is to say, a high Q value of a polygonal pattern indicates that the gain is high although the reception band is narrow. A low Q value indicates that the gain is low although the reception band is wide.

[0143] When the Q value of a polygonal pattern is high, in turn, the reception band becomes narrow, and the resonance frequency is shifted due to the influence of polarization. The reason for this can be described as below. In a case where a 0° electric field (non-polarized state) is present in a rectangular (quadrangular) pattern, an intensive current flows along the sides of the rectangular pattern, and resonance occurs at that portion. On the other hand, in a case where the electric field is inclined by 45° in the rectangular pattern, or the pattern is a circular pattern, the path through which an intensive current flows is not concentrated to be thin at the edge compared with the case where the rectangular pattern is at 0° . In other words, since the path of the current becomes wider, a region in which half-wavelength waves related to resonance are distributed is expanded, and thus resonance conditions are increased. It is considered that, as a result, the band width can be increased. For example, in the case of a rectangular pattern, when electromagnetic waves (TE waves) are received, an electric field is formed to extend in a straight line parallel to the sides, but in a case where the rectangle is rotated by 45° , an electric field in the pattern in a case where electromagnetic waves (TE waves) are received is formed so as to extend in the shape of an arc, that is, the distributions are clearly different from each other. That is to say, a rectangular (polygonal) pattern is disadvantageous in that since resonance is concentratedly occurs, communication easily depends on polarization, although receiving properties become high,

[0144] In order to improve this disadvantage, the pattern shape is basically polygonal, but at least one corner is set to be curved. Herein, an effect resulting from the fact that the corner is rounded off, that is, formed to be curved is to cause a resonance current to easily flow without stagnating at the corner, and to make the resonant region wider. As a result, the Q value becomes slightly smaller, but wide-band performance is exhibited, and thus polarization properties are improved. Thus, shift of the frequency at which the gain has a peak according to the direction in which electromagnetic waves are polarized can be suppressed low. Accordingly, a sheet member having excellent receiving properties can be realized in which a peak value of the gain is high, and shift of the frequency at which the gain has a peak according to the direction in which electromagnetic waves are polarized is small. (polarization loss is small).

[0145] When the conductive pattern portions 22 are basically polygonal and at least part of the corners is formed to

be curved, a sheet member having excellent receiving properties can be realized in which a peak value of the gain is high, and shift of the frequency at which the gain has a peak according to the direction in which electromagnetic waves are polarized is small.

5 [0146] Fig. 16 is an enlarged perspective view showing a part of the pattern layer 15, which is another embodiment constituting the sheet member 10 in the embodiment shown in Fig. 1. In the conductive pattern portions 22 in this case, the conductive pattern portions 12 have the radial pattern portions 30 and the rectangular pattern portions 31 that are two types of geometrical shapes. In Fig. 16, for facilitating understanding, the conductive pattern portions 22 are hatched with diagonal lines.

10 [0147] The radial pattern shape 30a has a shape in which four corners 41 in the intersecting portion 36 and corners 58 other than the corners 41 are formed into curves, more specifically, arcs, based on the base cross 40 indicated by the virtual line in Fig. 16. The corners 58 are formed in the shape of arcs projecting outward.

[0148] For example, the radial pattern shape 30a has a size in which the widths $a1x$ and $a1y$ of the shape portions 34 and 35 are the same, for example, 1.0 mm, and the lengths $a2x$ and $a2y$ of the shape portions 34 and 35 are the same, for example, 17.5 mm. The sizes of the arc at the arc-shaped corner, that is, the lengths of the sides excluding the oblique side of the substantially triangular portion 42, more specifically, the length $a3x$ of the side in the x direction and the length $a3y$ of the side in the y direction are the same, for example, 7.5 mm, and the radius of curvature R1 of the oblique side is 7.5 mm. Furthermore, the radius of curvature R3 of the outer peripheral sides of the corners 58 is 7.0 mm. Regarding the radial pattern gaps, the gap $c2x$ in the x direction and the gap $c2y$ in the y direction are the same, for example, 7.0 mm. Furthermore, in the rectangular pattern shapes 31a, the size $b1x$ in the x direction and the size $b1y$ in the y direction are the same, for example, 20.5 mm. Regarding the radial-rectangular portion gap between the radial pattern shapes 30a and the rectangular pattern shapes 31a, the gap $c1x$ in the x direction and the gap $c1y$ in the y direction are the same, for example, 1.5 mm. Also with this sort of configuration, a similar effect can be obtained.

25 [0149] Fig. 17 is an enlarged perspective view showing a part of the pattern layer 15 according to another embodiment constituting the sheet member 10 in the embodiment shown in Fig. 1. In the conductive pattern portions 22 in this case, the conductive pattern portions 12 have the radial pattern portions 30 and the rectangular pattern portions 31. In Fig. 17, for facilitating understanding, the conductive pattern portions 22 are hatched with diagonal lines.

[0150] The radial pattern shape 30a has a shape in which four corners 41 in the intersecting portion 36 and corners 58 other than the corners 41 are formed into curves, more specifically, arcs, based on the base cross 40 indicated by the virtual line in Fig. 17. The corners 58 are formed in the shape of arcs projecting outward.

30 [0151] For example, the radial pattern shape 30a has a size in which the widths $a1x$ and $a1y$ of the shape portions 34 and 35 are the same, for example, 2 mm, and the lengths $a2x$ and $a2y$ of the shape portions 34 and 35 are the same, for example, 10 mm. The sizes of the arc at the arc-shaped corner, that is, the lengths of the sides excluding the oblique side of the substantially triangular portion 42, more specifically, the length $a3x$ of the side in the x direction and the length $a3y$ of the side in the y direction are the same, for example, 3 mm, and the radius of curvature R1 of the oblique side is 0.5 mm. Furthermore, the radius of curvature R3 of the outer peripheral sides of the corners 58 is 0.5 mm. Regarding the radial pattern gaps, the gap $c2x$ in the x direction and the gap $c2y$ in the y direction are the same, for example, 2 mm. Furthermore, in the rectangular pattern shapes 31a, the size $b1x$ in the x direction and the size $b1y$ in the y direction are the same, for example, 6 mm. Regarding the radial-rectangular portion gap between the radial pattern shapes 30a and the rectangular pattern shapes 31a, the gap $c1x$ in the x direction and the gap $c1y$ in the y direction are the same, for example, 2 mm. Also with this sort of configuration, a similar effect can be obtained.

40 [0152] Fig. 18 is an enlarged perspective view showing a part of the pattern layer 15 according to another embodiment constituting the sheet member 10 in the embodiment shown in Fig. 1. The conductive pattern portions 22 in this case have the radial pattern portions 30 and the rectangular pattern portions 31. In Fig. 18, for facilitating understanding, the conductive pattern portions 22 are hatched with diagonal lines. The rectangular pattern shapes 31a in this embodiment have a shape obtained by angularly displacing the rectangular pattern shapes 31a of the conductive pattern portions 12 shown in Fig. 17 by 90° about the centroids, and the other constituent elements in the configuration are the same as those in the conductive pattern portions 22 shown in Fig. 17. Also with this sort of configuration, a similar effect can be obtained.

50 [0153] Fig. 19 is a front view of the pattern layer 15 according to another embodiment constituting the sheet member 10 in the embodiment shown in Fig. 1. Fig. 20 is an enlarged perspective view showing a part of the pattern layer 15 in Fig. 19. The conductive pattern portions 22 in this case have the radial pattern portions 30 in which the outlines of the corners 41 and 58 are formed at right angles and the rectangular pattern portions 31 in which the outlines of the corners are formed at right angles. The rectangular pattern shape 31a is disposed in a region enclosed by the radial pattern shapes 30a so as to be spaced away from the radial pattern shapes 30a by the radial-rectangular portion gaps $c1x$ and $c1y$ respectively in the x direction and the y direction. In Fig. 20, for facilitating understanding, the conductive pattern portions 22 are hatched with diagonal lines.

55 [0154] For example, the radial pattern shape 30a has a size in which the widths $a1x$ and $a1y$ of the shape portions 34 and 35 are the same, for example, 2.5 mm, and the lengths $a2x$ and $a2y$ of the shape portions 34 and 35 are the

same, for example, 16.0 mm. The radial-rectangular portion gaps c_{1x} and c_{1y} are the same, for example, 1.0 mm. Regarding the radial pattern gaps, the gap c_{2x} in the x direction and the gap c_{2y} in the y direction are the same, for example, 1.0 mm. Furthermore, in the rectangular pattern shapes 31a, the size b_{1x} in the x direction and the size b_{1y} in the y direction are the same, for example, 12.5 mm. Regarding the radial-rectangular portion gap between the radial pattern shapes 30a and the rectangular pattern shapes 31a, the gap c_{1x} in the x direction and the gap c_{1y} in the y direction are the same, for example, 1.0 mm. Also with this sort of configuration, a similar effect can be obtained.

[0155] Fig. 21 is a front view of the pattern layer 15 showing double-humped properties according to another embodiment constituting the sheet member 10 in the embodiment shown in Fig. 1. Fig. 22 is an enlarged perspective view of part of the pattern layer 15 in the embodiment shown in Fig. 21. In the pattern layer 15, the conductive pattern portions 22 are formed on the surface of the plate-shaped base 31 on the radio wave incident side. In Fig. 22, for facilitating understanding, the conductive pattern portions 22 are hatched with diagonal lines.

[0156] For example, the conductive pattern portions 22 in this embodiment may have a pattern in which pattern shape portions in the shape of a cross, having a single type of geometrical shape, are regularly arranged in a matrix so as to be spaced away from each other by gaps c_1 and c_2 in the x_1 direction and the y_1 direction of the rectangular coordinate system, which is obtained by angularly displacing the x direction and the y direction of the rectangular coordinate system by 45° about an axis perpendicular to the section of the diagram of Fig. 21. Thus, pattern shapes 61 constituting the conductive pattern portions 22 are formed in the shape of "X". The pattern shapes 61 in the shape of "X" are formed so that a rectangular shape portion 62 linearly extending in the x_1 direction and a rectangular shape portion 63 linearly extending in the y_1 direction intersect each other at right angles at an intersecting portion 64 so that the centroids of the shape portions 62 and 63 are overlapped. The shape portions 62 and 63 are displaced from each other by 90° about an axis perpendicular to the intersecting portion 64, and have the same shape. In the shape portions 62 and 63, for example, width $a_2 = b_1 = 2.5$ mm and length $a_1 = b_2 = 17$ mm. The shapes 61 may be arranged in the x_1 direction and the y_1 direction at gaps of $c_1 = c_2 = 1$ mm. The pattern shape 61 has a linear structure having end portions, and a plurality of pattern shapes 61 are arranged so as not to be connected to each other. Furthermore, the shape portions 62 and 63 constituting the pattern shapes 61 have a linear structure having end portions, the shape portions 62 and 63 function as a unit, and the shape portions 62 and 63 in the unit in which the number of the portions is two or more (two in this embodiment) intersect each other at right angles at a portion that is not at the end portions. Also with this sort of configuration, a similar effect can be obtained. With the double-humped properties, a tag can be proposed that operates at two or more frequencies using one sheet member 10. It will be appreciated that a plurality of antennas have to be arranged on the tag, or a plurality of chips also have to be arranged in a case where the chip cannot be shared. However, when communication is performed, for example, at both frequencies in a high MHz band and a 2.4 GHz band, a tag can be proposed in which communication properties are improved even in a case where a communication jamming member is present.

[0157] Fig. 23 is a front view of the pattern layer 15 showing double-humped properties according to another embodiment constituting the sheet member 10 in the embodiment shown in Fig. 1. Fig. 24 is an enlarged perspective view of part of the pattern layer 15 in the embodiment shown in Fig. 23. In the pattern layer 15, the conductive pattern portions 22 are formed on the surface of the plate-shaped base 31 on the radio wave incident side. In Fig. 24, for facilitating understanding, the conductive pattern portions 22 are hatched with diagonal lines. For example, the conductive pattern portions 22 in this embodiment may have a pattern in which rectangular loop pattern shapes (in the shape of closed loops), having a single type of geometrical shape, are regularly arranged in a matrix so as to be spaced away from each other by a gap $c_5 = c_6$ in the x direction and the y direction of the rectangular coordinate system. A plurality of pattern shapes are arranged so as not to be connected to each other. The gap may be set so that gap $c_5 = c_6 = 12$ mm. Furthermore, the size may be set so that, for example, line width $a_6 = b_5 = 1$ mm and one outer peripheral side $a_5 = b_6 = 10$ mm.

[0158] Fig. 25 is a front view of the pattern layer 15 according to another embodiment constituting the sheet member 10 in the embodiment shown in Fig. 1. Fig. 26 is an enlarged perspective view showing a part of the pattern layer 15 shown in Fig. 25. In Figs. 25 and 26, for facilitating understanding, the conductive pattern portions 22 are hatched with diagonal lines. The conductive pattern portions 22 in this case are formed so that the rectangular pattern portions 31, having a single type of geometrical shape, are regularly arranged in a matrix so as to be spaced away from each other by gaps (hereinafter, referred to as 'pattern gaps') d_{1x} and d_{1y} in the x direction and the y direction. While the conductive pattern portions 22 of the pattern layer 15 shown in Fig. 1 have the radial pattern portions 30 and the rectangular pattern portions 31, the conductive pattern portions 22 of the pattern layer 15 in Fig. 25 only have the rectangular pattern portions 31.

[0159] The rectangular pattern shapes 31a are in the shape of a square, and the length b_{1x} in the x direction and the length b_{1y} in the y direction are the same, for example, 21.0 mm. Furthermore, regarding a second pattern gap, which is the gap between pattern shapes 59 adjacent to each other in the x direction and the y direction, the gap d_{1x} in the x direction and the gap d_{1y} in the y direction are the same, for example, 1.5 mm. Also with this sort of configuration, a similar effect can be obtained.

[0160] Fig. 27 is a front view showing the pattern layer 15 according to another embodiment constituting the sheet member 10 in the embodiment shown in Fig. 1. In Fig. 27, for facilitating understanding, the conductive pattern portions 22 are hatched with diagonal lines. The conductive pattern portions 22 in this case are formed so that the rectangular pattern shapes 31a, having a single type of geometrical shape, are regularly arranged in a matrix so as to be spaced away from each other by the pattern gaps $d1x$ and $d1y$ in the x direction and the y direction. While the conductive pattern portions 22 of the pattern layer 15 shown in Fig. 1 have the radial pattern portions 30 and the rectangular pattern portions 31, the conductive pattern portions 22 of the pattern layer 15 in Fig. 25 only have the rectangular pattern portions 31.

[0161] The rectangular pattern shapes 31a are in the shape of a square, the length $b1x$ in the x direction and the length $b1y$ in the y direction are the same, for example, 21.0 mm, and the radius of curvature R2 of the corners is selected to be 10.0 mm. Furthermore, regarding a second pattern gap, which is the gap between the pattern shapes 59 adjacent to each other in the x direction and the y direction, the gap $d1x$ in the x direction and the gap $d1y$ in the y direction are the same, for example, 1.5 mm.

[0162] Fig. 28 is a front view showing the pattern layer 15 according to another embodiment constituting the sheet member 10 in the embodiment shown in Fig. 1. Fig. 29 is an enlarged perspective view showing a part of the pattern layer 15 shown in Fig. 28. In Figs. 28 and 29, for facilitating understanding, the conductive pattern portions 22 are hatched with diagonal lines. The conductive pattern portions 22 in this case are formed so that rectangular pattern shapes 31A and 31B, having two types of geometrical shapes, are regularly arranged in a matrix so as to be spaced away from each other by the pattern gaps $d1x$ and $d1y$ in the x direction and the y direction. The first and the second rectangular pattern shapes 31A and 31B are alternately arranged in the x direction. Furthermore, the first and the second rectangular pattern shapes 31A and 31B are alternately arranged in the y direction.

[0163] The first and the second rectangular pattern shapes 31A and 31B are substantially in the shape of a square, and the first rectangular pattern shape 31A and the second rectangular pattern shape 31B have different radii of curvature of the corners. The radius of curvature R2a of the corners of the first rectangular pattern portion 31A is selected to be smaller than the radius of curvature of the corners of the second rectangular pattern portion 31B. The length $b1x$ in the x direction and the length $b1y$ in the y direction are the same, for example, 21.0 mm, and the radii of curvature R2a and R2b of the corners are respectively selected to be 4.0 mm and 7.0 mm. Furthermore, regarding a second pattern gap, which is the gap between the pattern shapes 59 adjacent to each other in the x direction and the y direction, the gap $d1x$ in the x direction and the gap $d1y$ in the y direction are the same, for example, 1.5 mm. Also with this sort of configuration, a similar effect can be obtained.

[0164] Fig. 30 is a front view of the pattern layer 15 according to still another embodiment constituting the sheet member 10 in the embodiment shown in Fig. 1. In Fig. 30, for facilitating understanding, the conductive pattern portions 22 are hatched with diagonal lines. The conductive pattern portions 22 in this case are formed so that pattern shapes 66, having a single type of geometrical shape, are regularly arranged in a matrix so as to be spaced away from each other by the pattern gaps $d1x$ and $d1y$ in the x direction and the y direction.

[0165] The pattern shapes 66 are circular, and a radius r is, for example, 13 mm. Furthermore, regarding a pattern gap, which is the gap between the pattern shapes 66 adjacent to each other in the x direction and the y direction, the gap $d1x$ in the x direction and the gap $d1y$ in the y direction are the same, for example, 8 mm. Also with this sort of configuration, a similar effect can be obtained.

[0166] Fig. 31 is a front view of the pattern layer 15 according to still another embodiment constituting the sheet member 10 in the embodiment shown in Fig. 1. In Fig. 31, for facilitating understanding, the conductive pattern portions 22 are hatched with diagonal lines. While the conductive pattern portions 22 of the pattern layer 15 shown in Fig. 4 have the radial pattern portions 30 and the rectangular pattern portions 31, the conductive pattern portions 22 of the pattern layer 15 in Fig. 31 only have the radial pattern portions 30. Also with this sort of configuration, a similar effect can be obtained.

[0167] Fig. 32 is a front view showing a rectangular pattern shape 71 according to another embodiment. In this embodiment, instead of the rectangular pattern shapes 31a in Figs. 4, 16, 17, 18, 19, 25, 27, and 28, the rectangular pattern shape 71 shown in Fig. 32 is used. The other constituent elements in the configuration are the same as those in the embodiment shown in Fig. 1. While the rectangular pattern shapes 31a shown in Figs. 4, 16, 17, 18, 19, 25, 27, and 28 are planar patterns, the rectangular pattern shape 71 in Fig. 32 is a pattern in the shape of a strip (belt) forming a closed loop extending along the outer peripheral edge. Also with this sort of configuration, a similar effect can be obtained.

[0168] Fig. 33 is a front view showing a radial pattern shape 70 according to still another embodiment of the invention. In this embodiment, instead of the radial pattern shapes 30a shown in Figs. 4, 16, 17, 18, 19, and 31, the radial pattern shape 70 shown in Fig. 33 is used. The other constituent elements in the configuration are the same as those in the embodiment shown in Fig. 1. While the radial pattern shapes 30a shown in Figs. 4, 16, 17, 18, 19, and 31 are planar patterns, the radial pattern shape 70 in Fig. 33 is a pattern in the shape of a strip (belt) forming a closed loop extending along the outer peripheral edge. Also with this sort of configuration, a similar effect can be obtained.

[0169] Fig. 34 is a front view of the pattern layer 15 according to still another embodiment constituting the sheet member 10 in the embodiment shown in Fig. 1. In Fig. 34, for facilitating understanding, the conductive pattern portions

22 are hatched with diagonal lines. In the pattern layer 15, the conductive pattern portions 22 made of a metal are formed on the surface of the plate-shaped base 21 on the electromagnetic wave incident side.

[0170] The conductive pattern portions 22 are continuously formed in an electrically connected manner over a wide range, more specifically, the entire range of the sheet member 10, in directions intersecting the electromagnetic wave incident direction, more specifically, in the x direction and the y direction that are perpendicular to the thickness direction and that are perpendicular to each other. On the conductive pattern portions 22 functioning as continuously arranged conductive elements, a plurality of holes 80 and 81 are formed. Each of the holes 80 and 81 has a shape selected from polygons (including rectangles, which are types of quadrangles), circles, substantially polygonal shapes in which the outline at the corners is curved, shapes extending in the shape of a string, and combinations thereof. The shapes extending in the shape of a string are a linearly extending shapes, and may extend in a straight line, may extend in a curved line (e.g., a spiral), or may be bent at an intermediate portion.

[0171] More specifically, in the conductive pattern portions 22, a plurality of types of holes in which at least one of shape and size is different therebetween; more specifically, the cross holes 80 and the rectangular holes 81 are formed.

[0172] The cross hole 80 is formed in the shape of a cross, and a plurality of cross holes 80 are spaced away from each other by gaps (hereinafter, referred to as 'cross hole gaps') c2x and c2y. More specifically, the cross holes 80 are arranged so that radially extending portions 82 face each other, and the radially extending portions 82 facing each other are spaced away from each other by the cross hole gaps c2x and c2y. More specifically, for example, in this embodiment, the cross holes 80 may be formed in the shape of crosses radially extending in the x direction and the y direction that are perpendicular to each other, and regularly arranged in a matrix in which the cross hole gap c2x is interposed in the x direction and the cross hole gap c2y is interposed in the y direction.

[0173] The cross hole 80 has a shape in which a rectangular shape portion 84 linearly extending in the x direction and a rectangular shape portion 85 linearly extending in the y direction intersect each other at right angles at an intersecting portion 86 so that the centroids of the shape portions 84 and 85 are overlapped. The shape portions 84 and 85 are displaced from each other by 90° about an axis perpendicular to the intersecting portion 86, and have the same shape. Widths a1y and a1x of the shape portions 84 and 85 are the same, for example, 8 mm. Lengths a2x and a2y of the shape portions 84 and 85 are the same, for example, 38 mm. Regarding the cross hole gaps of the cross holes 80, the gap c2x in the x direction and the gap c2y in the y direction are the same, for example, 32 mm.

[0174] The rectangular holes 81 are arranged in a region enclosed by the cross holes 80 so as to be spaced away from the cross holes 80 by gaps (hereinafter, referred to as 'cross rectangular portion gaps') c1x and c1y so that the rectangular holes 81 cover the region enclosed by the cross holes 80. More specifically, the rectangular holes 81 divide the region enclosed by the cross holes 80 into four, and are arranged respectively in the regions obtained by the division. Accordingly, in one region enclosed by the cross holes 80, four rectangular holes 81 are formed.

[0175] The rectangular holes 81 are formed into a shape corresponding to the region enclosed by the cross holes 80. For example, in this embodiment, the cross hole 80 is in the shape of a cross as described above, and the region enclosed by the cross holes 80 is rectangular, that is, in the shape of a rectangle corresponding thereto. In a case where the shape portions 84 and 85 have the same shape as described above, the region enclosed by the cross holes 80 is in the shape of a square, the rectangular holes 81 are in the shape of a square.

[0176] Four rectangular holes 80 in one region enclosed by the cross holes 80 are arranged so that the edge side portions extend in either the x direction or the y direction, and the rectangular holes are arranged in a matrix in the x direction and the y direction. The region in which the four rectangular holes are arranged is in the shape of a quadrangle, more specifically, a square. Cross rectangular gaps c1x and c1y, which are the distance between the region and the cross holes 80, are formed to have the same shape throughout the entire periphery.

[0177] From another point of view, the holes 80 and 81 are arranged so that, when a hole group having four rectangular holes 81 and one cross hole 80 is taken as one unit, a plurality of unit hole groups are regularly arranged in directions intersecting the electromagnetic wave incident direction, more specifically, the groups are arranged in a matrix in the x direction and the y direction. In one hole group, four rectangular holes 81 are arranged in a matrix in the x direction and the y direction, and the cross hole 80 is disposed in a region in the shape of a cross formed between the four rectangular holes 81.

[0178] The size b1x in the x direction and the size b1y in the y direction of the rectangular holes 81 are the same, for example, 27 mm. Regarding the cross rectangular portion gaps between the cross holes 80 and the rectangular holes 81, the gap c1x in the x direction and the gap c1y in the y direction are the same, for example, 2 mm. Furthermore, regarding gaps (hereinafter, referred to as 'rectangular hole gaps') c3x and c3y between four rectangular holes 81 in the region enclosed by the cross holes 80, the gap c3x in the x direction and the gap c3y in the y direction are the same, for example, 4 mm.

[0179] Accordingly, the conductive pattern portion 22 has, as one unit element portion 101, an element portion having a shape in which the above-described unit hole group is cut out from a square defined by two sides parallel to the x direction and two sides parallel to the y direction. The unit element portion 101 is symmetric about a center point P101 and is rotationally symmetric having the same shape each time the unit element portion 101 is rotated by 90° about the

center point P101. The unit element portion 101 is symmetric with respect to a straight line that passes through the center point P101 and that is parallel to the x direction, and is symmetric with respect to a straight line that passes through the center point P101 and that is parallel to the y direction. The conductive pattern portions 22 have a shape in which a plurality of unit element portions 101 are moved in parallel in the x direction and the y direction to be arranged in a matrix. This shape is also a shape in which the unit element portions 101 and symmetrical unit element portions that are symmetric to the unit element portions 101 with respect to the x direction and the y direction are alternately arranged in a checkered pattern. A size $f1x$ in the x direction and a size $f1y$ in the y direction, which also function as the arrangement pitch of the unit element portions 101, are, for example, 70 mm. The cross holes 80 and the rectangular holes 81 are polygonal, and all corners are sharp-pointed, that is, formed in the shape of angled edges. Also with this sort of configuration, a similar effect can be obtained.

[0180] Fig. 35 is a front view showing another pattern layer 15 whose configuration is different in size from that of the pattern layer 15 in Fig. 34, according to still another embodiment of the invention. In Fig. 34, for facilitating understanding, the conductive pattern portions 22 are hatched with diagonal lines. Since the configuration, except for size, is similar to the configuration described with reference to Fig. 33, the corresponding constituent elements are denoted by the same numerals, and only size, which is a different aspect, will be described. Instead of the pattern layer 15 shown in Fig. 3, this pattern layer 15 can be used for the sheet member 10. The widths $a1y$ and $a1x$ of the shape portions 84 and 85 are, for example, 6 mm, and the lengths $a2x$ and $a2y$ of the shape portions 84 and 85 are, for example, 132 mm. The cross hole gaps $c2x$ and $c2y$ are, for example, 8 mm. Furthermore, the sizes $b1x$ and $b1y$ of the rectangular holes 81 are, for example, 50 mm. The cross rectangular gaps $c1x$ and $c1y$ are, for example, 7 mm. Furthermore, the rectangular hole gaps $c3x$ and $c3y$ are, for example, 20 mm. Furthermore, the sizes $f1x$ and $f1y$ of the unit element portion 101 are, for example, 140 mm. Also in the conductive pattern portions 22 shown in Fig. 35, the rectangular holes 81 correspond to the same size portions. Hereinafter, the same size portions may be denoted by the same numeral 81 as that for the rectangular holes.

[0181] Fig. 36 is a front view showing another pattern layer 15 that can be used as still another embodiment of the invention. In Fig. 36, for facilitating understanding, the conductive pattern portions 22 are hatched with diagonal lines. The constituent elements corresponding to those in the pattern layer 15 shown in Fig. 34 are denoted by the same numerals, and only different constituent elements in the configuration will be described. Instead of the pattern layer 15 shown in Fig. 3, this pattern layer 15 can be used for the sheet member 10. In the pattern layer 15 shown in Fig. 36, the conductive pattern portions 22 are different in shape from the conductive pattern portions 22 shown in Fig. 34. In the conductive pattern portions 22 shown in Fig. 36, a plurality of holes 120 are formed.

[0182] Each of the holes 120 is in the shape of a polygon in which all interior angles are smaller than 180° , and may be in the shape of a regular polygon. In this embodiment, each of the holes 120 is quadrangular, and specifically, rectangular. The rectangular shapes include square shapes. More specifically, each of the holes 120 is in the shape of a square defined by two sides parallel to the x direction and two sides parallel to the y direction, and the rectangular holes 120 are arranged in a predetermined pattern that is not a matrix pattern.

[0183] More specifically, the conductive pattern portion 22 has a unit element portion 101 having a shape in which four rectangles (rectangles obtained by cutting each the holes 120 into half along a straight line parallel to one side thereof) are formed as portions cut out from a square defined by two sides parallel to the x direction and two sides parallel to the y direction. The unit element portion 101 has a shape in which each of the four cut-out portions is disposed at each side portion of the unit element portion 101 so that the side of the cut-out portion matches the side of the unit element portion 101 and opens outward. Furthermore, the center positions of the four cut-out portions are displaced from the midpoints of the respective sides of the unit element portion 101 by the same displacement amount in one peripheral direction about the center position P101 of the unit element portion 101. In the four cut-out portions, the size of the side matching the side of the unit element portion 101 is the same as the size of one of two adjacent sides of the hole 120, and the size of the side perpendicular to the side of the unit element portion 101 is $1/2$ of the size of the other side of the of two adjacent sides of the hole 120.

[0184] The unit element portion 101 is symmetric about a center point P101, and is rotationally symmetric having the same shape each time the unit element portion 101 is rotated by 90° about the center point P101. The conductive pattern portions 22 have a shape in which a plurality of unit element portions 101 and a plurality of symmetrical unit element portions 101a that are symmetric to the unit element portions 101 with respect to the x direction and the y direction are alternately arranged in a checkered pattern. The pattern layer 15 with the conductive pattern portions 22 having this shape can be used in a similar manner instead of the pattern layer 15 shown in Fig. 3, and the sheet member 10 can be formed including this pattern layer 15 shown in Fig. 35. The size $f1x$ in the x direction and the size $f1y$ in the y direction of the unit element portion 101 are, for example, 70 mm.

[0185] The pattern layer 15 shown in Fig. 36 will be described more specifically. Each of the holes 120 is in the shape of a square. Each of the cut-out portions formed in the unit element portion 101 is in the shape of a rectangle in which the size of the longer side is the same as the size of one side of the hole 120, and the size of the shorter side is $1/2$ of the size of one side of the hole 120. Each of the cut-out portions is arranged so that the longer side matches the side

of the unit element portion 101. When the unit element portions 101 in which the cut-out portions are formed and the symmetrical unit element portions 101a that are symmetric thereto are arranged in a checkered pattern as described above, the pattern layer 15 in which a plurality of square holes 120 are formed can be obtained. A size $g1x$ in the x direction and a size $g1y$ in the y direction of each of the holes 120 are the same, for example, 40 mm. In this embodiment, the holes 120 correspond to the same size portions. Hereinafter, the same size portions may be denoted by the same numeral as that for the holes 120.

[0186] Fig. 37 is a front view showing another pattern layer 15 that can be used as still another embodiment of the invention. In Fig. 37, for facilitating understanding, the conductive pattern portions 22 are hatched with diagonal lines. The constituent elements corresponding to those in the pattern layer 15 shown in Fig. 34 are denoted by the same numerals, and only different constituent elements in the configuration will be described. Instead of the pattern layer 15 shown in Fig. 3, this pattern layer 15 can be used for the sheet member 10. In the pattern layer 15 shown in Fig. 37, the conductive pattern portions 22 are different in shape from the conductive pattern portions 22 shown in Fig. 34.

[0187] In the conductive pattern portions 22 shown in Fig. 37, a plurality of holes 121 are formed. Each of the holes 121 has a shape in which two C-shaped portions 125, in which a plurality of line segment portions are bent at right angles and connected to be substantially in the shape of Cs, are arranged so that the recessed sides oppose each other, and the center portions of the C-shaped portions are connected by a linear connecting portion 126. The holes 121 having this shape are formed in an arrangement following a predetermined pattern in which one of the C-shaped portions 125 is fitted to the recessed portion on one side with respect to the connecting portion 126 of another hole 121, and the C-shaped portions 125 are intertwined. Each line segment portion of each of the C-shaped portions 125 and each of the connecting portions 126 are parallel to the x direction or the y direction.

[0188] More specifically, the conductive pattern portion 22 has a unit element portion 101 having a shape in which four hook-shaped portions are arranged in the peripheral direction and cut out in the shape of a spiral from a square defined by two sides parallel to the x direction and two sides parallel to the y direction. Each hook portion has a shape in which five line segment portions are connected at four bent portions, and the size of the line segment portion becomes smaller toward the inner side of the unit element portion 102. The line segment portion on the outermost side is disposed along a side of the unit element portion 101, and opens outward in the unit element portion 101. The unit element portion 101 has a shape in which a plurality of (five in this embodiment) line segment portions parallel to the x direction or the y direction are connected so as to be bent at right angles, and formed in the shape of a spiral extending outward in the radial direction while being rotated toward one side in the peripheral direction, so that a fylfot-shaped portion where the intersecting portions are integrally connected at the center point P10 is formed.

[0189] The unit element portion 101 is symmetric about a center point P101, and is rotationally symmetric having the same shape each time the unit element portion 101 is rotated by 90° about the center point P101. The conductive pattern portions 22 have a shape in which a plurality of unit element portions 101 and a plurality of symmetrical unit element portions 101a that are symmetric to the unit element portions 101 with respect to the x direction and the y direction are alternately arranged in a checkered pattern. In this manner, the conductive pattern portions 22 have a shape in which a plurality of spiral portions are mutually connected. The pattern 15 with the conductive pattern portions 22 having this shape can be used in a similar manner instead of the pattern layer 15 shown in Fig. 3, and the sheet member 10 can be formed including this pattern layer 15 shown in Fig. 37. The size $f1x$ in the x direction and the size $f1y$ in the y direction of the unit element portion 101 are, for example, 63 mm.

[0190] From another point of view, in the conductive pattern portions 22 shown in Fig. 37, the holes 121 are formed so that a plurality of different size portions 127 extending in one direction are arranged in a direction intersecting the one direction, for example, focusing on a region S1 enclosed by the virtual line. In the region S1, the different size portions 127 extend in the x direction and are arranged in the y direction. In the conductive pattern portions 22, a plurality of regions having the same shape as the region S1 are present, and a plurality of regions having the shape obtained by rotating the region S1 by 90° are present.

[0191] In this manner, the conductive pattern portions 22 shown in Fig. 37 are continuously arranged conductive elements that are continuously formed in an electrically connected manner across a face intersecting the electromagnetic wave incident direction, and a plurality of holes 121 are formed therein. The holes 121 have the different size portions 127 in which the sizes in two directions intersecting each other at right angles in a state where the conductive pattern portions 22 are arranged along a plane are different from each other. The different size portions 127 are arranged in a direction of the smaller size of the sizes in the two directions. Herein, the two directions are the x direction and the y direction. A width $w127$ of the different size portions 127, which is the smaller size of the sizes in the two directions of the different size portions 127 is, for example, 4 mm, and a length of the different size portions 127, which is the larger size of the sizes in the two directions of the different size portions 127, is twice or more than the width $w127$.

[0192] Fig. 38 is a front view showing another pattern layer 15 that can be used as still another embodiment of the invention. In Fig. 38, for facilitating understanding, the conductive pattern portions 22 are hatched with diagonal lines. The constituent elements corresponding to those in the pattern layer 15 shown in Fig. 34 are denoted by the same numerals, and only different constituent elements in the configuration will be described. Instead of the pattern layer 15

shown in Fig. 3, this pattern layer 15 can be used for the sheet member 10. In the pattern layer 15 shown in Fig. 38, the conductive pattern portions 22 are different in shape from the conductive pattern portions 22 shown in Fig. 34.

5 **[0193]** In the conductive pattern portions 22 shown in Fig. 38, a plurality of holes 130 are formed. Each of the holes 130 has the overall shape of "I" in which two linear end wall portions 131 that are spaced away from each other and extend in parallel are connected at the center portions by a linear connecting portion 132. The holes 130 having this shape are formed in an arrangement following a predetermined pattern in which one of the end wall portions 131 is fitted to the recessed portion on one side with respect to the connecting portion 132 of another hole 130. Each of the end wall portions 131 and each of the connecting portions 132 are parallel to the x direction or the y direction.

10 **[0194]** More specifically, the conductive pattern portion 22 has a unit element portion 101 having a shape in which four L-shaped portions are arranged in the peripheral direction and cut out in the shape of a spiral from a square defined by two sides parallel to the x direction and two sides parallel to the y direction in a state where one straight line portion of each L-shaped portion is disposed along a side of the square and opens outward. The unit element portion 101 has a shape in which a plurality of (two in this embodiment) line segments are connected so as to be bent at right angles, to be in the shape of a spiral extending outward in the radial direction from a square base whose center matches the center point P101 while being rotated toward one side in the peripheral direction.

15 **[0195]** The unit element portion 101 is symmetric about a center point P101, and is rotationally symmetric having the same shape each time the unit element portion 101 is rotated by 90° about the center point P101. The conductive pattern portions 22 have a shape in which a plurality of unit element portions 101 and a plurality of symmetrical unit element portions 101a that are symmetric to the unit element portions 101 with respect to the x direction and the y direction are alternately arranged in a checkered pattern. In this manner, the conductive pattern portions 22 have a shape in which a plurality of spiral portions are mutually connected. The pattern layer 15 with the conductive pattern portions 22 having this shape can be used in a similar manner instead of the pattern layer 15 shown in Fig. 3, and element receiving means 20 can be formed including this pattern layer 15 shown in Fig. 38. The size f1x in the x direction and the size fly in the y direction of the unit element portion 101 are, for example, 41 mm.

25 **[0196]** From another point of view, in the conductive pattern portions 22 shown in Fig. 38, the holes 130 are formed so that a plurality of different size portions 137 extending in one direction are arranged in a direction intersecting the one direction, for example, focusing on a region S2 enclosed by the virtual line. In the region S2, the different size portions 137 extend in the x direction and are arranged in the y direction. In the conductive pattern portions 22, a plurality of regions having the same shape as the region S2 are present, and a plurality of regions having the shape obtained by rotating the region S2 by 90° are present.

30 **[0197]** In this manner, the conductive pattern portions 22 shown in Fig. 38 are continuously arranged conductive elements that are continuously formed in an electrically connected manner across a face intersecting the electromagnetic wave incident direction, and a plurality of holes 130 are formed therein. The holes 130 have the different size portions 137 in which the sizes in two directions intersecting each other at right angles in a state where the conductive pattern portions 22 are arranged along a plane are different from each other. The different size portions 137 are arranged in a direction of the smaller size of the sizes in the two directions. Herein, the two directions are the x direction and the y direction. A width w137 of the different size portions 137, which is the smaller size of the sizes in the two directions of the different size portions 137 is, for example, 3 mm, and a length of the different size portions 137, which is the larger size of the sizes in the two directions of the different size portions 137, is twice or more than the width w137.

35 **[0198]** Fig. 39 is a front view showing another pattern layer 15 that can be used as still another embodiment of the invention. In Fig. 39, for facilitating understanding, the conductive pattern portions 22 are hatched with diagonal lines. The constituent elements corresponding to those in the pattern layer 15 shown in Fig. 34 are denoted by the same numerals, and only different constituent elements in the configuration will be described. Instead of the pattern layer 15 shown in Fig. 3, this pattern layer 15 can be used for the sheet member 10. In the pattern layer 15 shown in Fig. 39, the conductive pattern portions 22 are different in shape from the conductive pattern portions 22 shown in Fig. 34.

40 **[0199]** In the conductive pattern portions 22 shown in Fig. 39, a plurality of holes 135 are formed. Each of the holes 135 is in the shape of an elongated rectangle, and formed in an arrangement following a predetermined pattern in which the holes 135 are arranged in a stripe pattern. Each of the holes 135 is parallel to the x direction or the y direction, more specifically, the conductive pattern portion 22 has a unit element portion 101 having a shape in which a plurality of holes 135 arranged in a stripe pattern are cut out from a square defined by two sides parallel to the x direction and two sides parallel to the y direction. In the unit element portion 101, four regions are obtained by dividing the unit element portion 101 along a straight line parallel to the x direction and a straight line parallel to the y direction that intersect each other at right angles at the center point P101, a plurality of (six in this embodiment) holes 135 are arranged substantially at equal spacings in a stripe pattern parallel to the x direction in two regions arranged in one of the diagonal directions, and a plurality of (six in this embodiment) holes 135 are arranged substantially at equal spacings in a stripe pattern parallel to the y direction in two regions arranged in the other diagonal direction.

45 **[0200]** The unit element portion 101 is symmetric about a center point P101, and is rotationally symmetric having the same shape each time the unit element portion 101 is rotated by 90° about the center point P101. The conductive pattern

portions 22 have a shape in which a plurality of unit element portions 101 are arranged in a matrix. This shape is also a shape in which the unit element portions 101 and symmetrical unit element portions that are symmetric to the unit element portions 101 with respect to the x direction and the y direction are alternately arranged in a checkered pattern. Furthermore, the shape of the conductive pattern portions 22 also may be a shape in which portions in which six holes 135 extending in the x direction are arranged in the y direction in a square region defined by two sides parallel to the x direction and two sides parallel to the y direction and portions in which six holes 135 extending in the y direction are arranged in the x direction in a similar square region are alternately arranged in a checkered pattern. The pattern layer 15 with the conductive pattern portions 22 having this shape can be used in a similar manner instead of the pattern layer 15 shown in Fig. 4, and the element receiving means 100 can be formed including this pattern layer 15 shown in Fig. 14. The size $f1x$ in the x direction and the size $f1y$ in the y direction of the unit element portion 101 are, for example, 129 mm.

[0201] From another point of view, in the conductive pattern portions 22 shown in Fig. 39, the holes 135 are formed so that a plurality of different size portions extending in one direction are arranged in a direction intersecting the one direction, for example, focusing on a region S3 enclosed by the virtual line. In the configuration in Fig. 39, the holes 135 respectively correspond to the different size portions. In the region S3, the holes 135 functioning as the different size portions extend in the x direction and are arranged in the y direction. In the conductive pattern portions 22, a plurality of regions having the same shape as the region S3 are present, and a plurality of regions having the shape obtained by rotating the region S3 by 90° are present.

[0202] In this manner, the conductive pattern portions 22 shown in Fig. 39 are continuously arranged conductive elements that are continuously formed in an electrically connected manner across a face intersecting the electromagnetic wave incident direction, and a plurality of holes 135 are formed therein. The holes 135 correspond to the different size portions in which the sizes in two directions intersecting each other at right angles in a state where the conductive pattern portions 22 are arranged along a plane are different from each other. Hereinafter, the different size portions may be denoted by the same numeral 135 as that for the holes 135. The holes 135 functioning as the different size portions are arranged in a direction of the smaller size of the sizes in the two directions. Herein, the two directions are the x direction and the y direction. A width $w135$ of the holes 135, which is the smaller size of the sizes in the two directions of the holes 135, is, for example, 6 mm, and a length of the holes 135, which is the larger size of the sizes in the two directions of the holes 135, is twice or more than the width $w135$.

[0203] Fig. 40 is an enlarged front view showing a part of the pattern layer 15 according to another embodiment constituting the sheet member 10 in the embodiment shown in Fig. 1. Fig. 41 is a front view of the pattern layer 15 in which a part of Fig. 40 is enlarged. In Figs. 40 and 41, for facilitating understanding, the conductive pattern portions 22 are hatched with diagonal lines. This pattern layer 5 is a pattern layer used instead of the above-described pattern layer 15 shown in Fig. 1, and is similar to the above-described pattern layer 15 shown in Fig. 1. Thus, the corresponding portions are denoted by the same numerals, and a description of the same portions may be omitted. The pattern layer 15 in Fig. 40 is different, in the shape and the size of the conductive pattern portions 22, from the pattern layer 15 in Fig. 1. The conductive pattern portions 22 in Fig. 40 have a plurality of radial pattern portions 30 and a plurality of substantially rectangular patterns 31.

[0204] Each of the radial pattern portion 30 is formed into a radial shape, and a plurality of radial pattern portions 30 are spaced away from each other. Each of the radial pattern portion 30 is formed substantially in the shape of a cross radially extending in the x direction and the y direction that intersect each other at right angles in a virtual plane, and the radial pattern portion are regularly arranged in a matrix in the x direction and the y direction. Each of the radial pattern portion 30 has a shape in which four corners 41 in the intersecting portion 36 of a cross (hereinafter, referred to as a 'base cross') 40 indicated by the virtual line in Fig. 41 are formed into curves, more specifically, arcs. The base cross 40 has a shape in which a first rectangular portion 34 linearly extending in the x direction and a second rectangular portion 35 linearly extending in the y direction intersect each other at right angles at the intersecting portion 36 so that the centers of the rectangular portions 34 and 35 are overlapped. The rectangular portions 34 and 35 are displaced from each other by 90° about an axis perpendicular to the intersecting portion 36, and have the same shape. Four first substantially right-angled triangles 42 are arranged on this base cross 40 so that the corners of the first substantially right-angled triangles 42 are respectively accommodated in the four corners 41 of the intersecting portion 36. The first substantially right-angled triangles 42 are substantially in the shape of a right-angled isosceles triangle in which the oblique side opposing the right-angled corner is curved in the shape of an arc recessed toward the right-angled corner. Each of the radial pattern portion 30 is four-fold rotationally symmetric, is symmetric about the centers of the rectangular portions 34 and 35, is symmetric with respect to two straight lines that pass through the centers of the rectangular portions 34 and 35 and that are parallel to the longer sides of the rectangular portions, and is symmetric with respect to two straight lines obtained by displacing, by 45°, the two straight lines that pass through the centers of the rectangular portions 34 and 35 and that are parallel to the longer sides of the rectangular portions.

[0205] The substantially rectangular pattern 31 is disposed in a region enclosed by the radial pattern portions 30 so as to be spaced away from the radial pattern portions 30 so that the substantially rectangular pattern 31 covers the region enclosed by the radial pattern portions 30. The region enclosed by four radial pattern portions 31 in which two

radial pattern portions 31 adjacent to each other in the x direction and two radial pattern portions 31 adjacent to the two radial pattern portions 31 on either one side in the y direction are combined is substantially square. One substantially rectangular pattern 31 is disposed so as to be fitted to this region. Each of the substantially rectangular patterns 31 is formed into a shape similar to the shape of the region enclosed by the four radial pattern portions 31.

5 [0206] Each of the radial pattern portion 30 is substantially in the shape of a cross as described above, and each region enclosed by the radial pattern portion 30 is in the shape of a quadrangle with rounded corners in which the corners of the rectangle are formed in the shape of arcs. Examples of the rectangle on which this quadrangle with rounded corners is based include rectangles in which the longer sides are different in size from the shorter sides and squares in which the longer sides have the same size as that of the shorter sides. In this embodiment, each region enclosed by the radial pattern portion 30 is in the shape of a quadrangle with rounded corners, which is substantially square, and each of the substantially rectangular patterns 31 is in the shape of a quadrangle with rounded corners, which is substantially square.

10 [0207] Each of the substantially rectangular patterns 31 has a shape in which four corners 26 of the base square 25 are changed into the shape of arcs. Each of the substantially rectangular patterns 31 has a shape in which four second substantially right-angled triangles 27 arranged so that the right-angled corners are accommodated in the corners of the base square 25 are removed from the base square 25. The second substantially right-angled triangles 27 are substantially in the shape of a right-angled isosceles triangle in which the oblique side opposing the right-angled corner is curved in the shape of an arc recessed toward the right-angled corner. Each of the substantially rectangular patterns 31 is disposed so that the center of the base square 25 matches the center of a square formed by connecting the centers of the base crosses of four radial pattern portions 31 arranged around the base square 25, and each side of the base square 25 extends in either the x direction or the y direction. Each of the substantially rectangular patterns 12 is four-fold rotationally symmetric, is symmetric about the center of the base square 25, is symmetric with respect to two diagonal lines of the base square 25, and is symmetric with respect to two straight lines that pass through the center of the base square 25 and that are parallel to any side.

15 [0208] The pattern layer 15 in which the patterns 12 having the radial pattern portions 30 and the substantially rectangular patterns 31 are formed has an area ratio in which, when the area of the entire region of the pattern layer 15 is taken as 1, the area of the region in which the conductive pattern portions 22 are formed (hereinafter, referred to as a 'pattern area') is 0.6 or more.

20 [0209] A width $a1y$ of the first rectangular portion 34 and a width $a1x$ of the second rectangular portion 35 are the same, for example, 0.05 mm or more and 10 mm or less. A length $a2x$ of the first rectangular portion 34 and a length $a2y$ of the second rectangular portion 35 are the same, for example, 1 mm or more and 100 mm or less. The lengths of two sides of the first substantially right-angled triangle 42 having the right-angled corner interposed therebetween, that is, the length $a3x$ of the side extending in the x direction and the length $a3y$ of the side extending in the y direction, of the two sides, are the same, for example, 0.1 mm or more and 50 mm or less, and the radius of curvature $R1$ of the oblique side of the first substantially right-angled triangles 42 is, for example, 1 mm or more and 100 mm or less. An angle $\theta3$ formed by two straight lines connecting the center point of the arc at the oblique side of the first substantially right-angled triangle 42 and ends of the oblique side of the first substantially right-angled triangle 42 is 5° or more and 45° or less. A distance $c2x$ between the first rectangular portions 34 of two radial pattern portions 30 adjacent to each other in the x direction and a distance $c2y$ between the second rectangular portions 35 of two radial pattern portions 30 adjacent to each other in the y direction are the same, for example, 0.1 mm or more and 100 mm or less.

25 [0210] Furthermore, the size $b1x$ in the x direction and the size $b1y$ in the y direction of the base square 25 are the same, for example, 1 mm or more and 100 mm or less. The sizes $b1x$ and $b1y$ of the base square 25 are the size in the x direction and the size in the y direction of the substantially rectangular pattern 31. The lengths of two sides of the second substantially right-angled triangle 27 having the right-angled corner interposed therebetween, that is, the length $b2x$ of the side extending in the x direction and the length $b2y$ of the side extending in the y direction, of the two sides, are the same, for example, 0.1 mm or more and 50 mm or less, and the radius of curvature $R2$ of the oblique side of the second substantially right-angled triangle 27 is, 1 mm or more and 100 mm or less.

30 [0211] Furthermore, a width $c1$ of a gap (hereinafter, referred to as a 'radial-rectangular portion gap') between the radial pattern portion 30 and the substantially rectangular pattern 31 continuously changes from a minimum width $c1min$ to a maximum width $c1max$ in a direction in which the gap extends. The minimum width $c1min$ of the radial-rectangular portion gap is the size from the radial pattern portion 30 at ends in the longer-side direction of the rectangular portions 34 and 35 to the substantially rectangular pattern 31, for example, 0.1 mm or more and 20 mm or less. The maximum width $c1max$ of the radial-rectangular portion gap is the size along a straight line equally dividing the right-angled corner of the substantially right-angled triangles 42 and 27 into two, for example, 0.5 mm or more and 50 mm or less.

35 [0212] In this manner, the width $c1$ of the radial-rectangular portion gap continuously changes in a direction in which the gap extends. A change ratio $\Delta c1$ of the width $c1$ of the radial-rectangular portion gap is, for example, 0.001 or more and 10 or less. The change ratio $\Delta c1$ of the width $c1$ of the radial-rectangular portion gap is the amount of change in the width $c1$ of the radial-rectangular portion gap per unit size along the edge side of the radial pattern portion 30. In this

embodiment, the change ratio $\Delta c1$ is not constant, and becomes smaller from the position of the minimum width $c1min$ toward the position of the maximum width $c1max$.

[0213] The change ratio $\Delta c1$ is represented by Formula (1). The coefficient k in Formula (1) is represented by Formula (2).

5

$$\Delta c1 = \frac{c1max - c1min}{k} \quad \dots (1)$$

10

$$k = \left(\frac{a2x - a1x}{2} - a3x \right) + \left(\frac{a2y - a1y}{2} - a3y \right) + \frac{2\pi R1}{360} \quad \dots (2)$$

15

[0214] In a case where the frequency of electromagnetic waves that are to be absorbed by the sheet member 10 is in a UHF band, the widths $a1x$ and $a1y$ of the rectangular portions 34 and 35 are, for example, 1 mm, the lengths $a2x$ and $a2y$ of the rectangular portions 34 and 35 are, for example, 20 mm, the lengths $a3x$ and $a3y$ of the two sides of the first substantially right-angled triangle 42 having the right-angled corner interposed therebetween are, for example, 6.5 mm, and the radius of curvature $R1$ of the oblique side is 6.5 mm. In a case where the frequency of electromagnetic waves that are to be absorbed by the sheet member 10 is in a UHF band, the sizes $b1x$ and $b1y$ of the base square 25 are, for example, 25 mm, the lengths $b2x$ and $b2y$ of two sides of the second substantially right-angled triangle 27 having the right-angled corner interposed therebetween are, for example, 10.5 mm, and the radius of curvature $R2$ of the oblique side is, 10.5 mm. In a case where the frequency of electromagnetic waves that are to be absorbed by the sheet member 10 is in a UHF band, the minimum width $c1min$ of the width $c1$ of the radial-rectangular portion gap is, for example, 0.5 mm, the maximum width $c1max$ is, for example, 2 mm, and the change ratio $\Delta c1$ is, for example, 0.15. In a case where the frequency of electromagnetic waves that are to be absorbed by the sheet member 10 is in a UHF band, the gaps $c2x$ and $c2y$ between the radial pattern portions are, for example, 7 mm.

20

25

30

35

40

45

[0215] In a case where the frequency of electromagnetic waves that are to be absorbed by the sheet member 10 is in a 2.4 GHz band, the widths $a1x$ and $a1y$ of the rectangular portions 34 and 35 are, for example, 0.5 mm, the lengths $a2x$ and $a2y$ of the rectangular portions 34 and 35 are, for example, 17.5 mm, the lengths $a3x$ and $a3y$ of the two sides of the first substantially right-angled triangle 42 having the right-angled corner interposed therebetween are, for example, 5 mm, and the radius of curvature $R1$ of the oblique side is 5 mm. In a case where the frequency of electromagnetic waves that are to be absorbed by the sheet member 10 is in a 2.4 GHz band, the sizes $b1x$ and $b1y$ of the base square 25 are, for example, 20.5 mm, the lengths $b2x$ and $b2y$ of two sides of the second substantially right-angled triangle 27 having the right-angled corner interposed therebetween are, for example, 8 mm, the radius of curvature $R2$ of the oblique side is, 8 mm. In a case where the frequency of electromagnetic waves that are to be absorbed by the sheet member 10 is in a 2.4 GHz band, the minimum width $c1min$ of the width $c1$ of the radial-rectangular portion gap is, for example, 0.5 mm, the maximum width $c1max$ is, for example, approximately 1.7 mm, and the change ratio $\Delta c1$ is, for example, 0.14. In a case where the frequency of electromagnetic waves that are to be absorbed by the sheet member 10 is in a 2.4 GHz band, the gaps $c2x$ and $c2y$ between the radial pattern portions are, for example, 2.5 mm..

[0216] With the sheet member 10 including the pattern layer 15 in which the conductive pattern portions 22 having the radial pattern portions 30 and the substantially rectangular patterns 31 are formed, a similar effect can be obtained as in the case of the sheet member 10 including the pattern layer 15 in Fig. 3. Furthermore, in the pattern layer 15 in Figs. 40 and 41, at least part of pattern portions in among the conductive pattern portions 22 has the outer shape including curved portion. In this embodiment, all of the conductive pattern portions 22 have the outer shape including curved portion. In this sort of conductive pattern portions 22, a resonance current when receiving electromagnetic waves smoothly flows at the curved portions.

[0217] Furthermore, as another embodiment of the invention, the layer configuration of the sheet member 10 also may be a layer configuration other than that in Fig. 1.

50

55

[0218] Fig. 42 is a cross-sectional view showing a sheet member 10a according to still another embodiment of the invention. As shown in Fig. 42, the sheet member 10a may have the configuration in which the first storage layer 14, the pattern layer 15, the second storage layer 13, the reflection area forming layer 12, and the attachment layer 11 are overlaid in this order from the electromagnetic wave incident side. The configuration of the first storage layer 14, the pattern layer 15, the second storage layer 13, the reflection area forming layer 12, and the attachment layer 11 is similar to that described above. Also with this sort of configuration, a similar effect can be obtained. In the embodiment in Fig. 42, constituent elements corresponding to those in Fig. 1 are denoted by the same numerals. In this embodiment, the first and the second storage layers 14 and 13 may be similar storage layers. The layers may be the same storage layer, or may be different storage layers. The storage layers are not limited to the first and the second layers, and there is no limitation on the number of layers overlaid. The storage layers may be dielectric layers, may be magnetic layers, or may

be a combination thereof. As shown in Fig. 44 below, the storage layer also may be a single layer.

[0219] Fig. 43 is a cross-sectional view showing a sheet member 10b according to still another embodiment of the invention. As shown in Fig. 43, the sheet member 10b may have the configuration in which a storage layer at the first order (for example, a third storage layer 130), the pattern layer 15, a storage layer at the second order (for example, the first storage layer 14), a storage layer at the third order (for example, the second storage layer 13), the reflection area forming layer 12, and the attachment layer 11 are overlaid in this order. As in the case of the first and the second storage layers 14 and 13, the third storage layer 130 is a storage layer, and may be a dielectric member or may be a magnetic member. The pattern layer 15, the first storage layer 14, the second storage layer 13, the reflection area forming layer 12, and the attachment layer 11 are similar to those in the foregoing embodiments. In the embodiment in Fig. 43, constituent elements corresponding to those in Fig. 1 are denoted by the same numerals. In this embodiment, the first and the second storage layers 14 and 13 and the third storage layer 130 may be similar storage layers. The layers may be the same storage layer, or may be different storage layers.

[0220] Fig. 44 is a cross-sectional view showing a sheet member 10c according to still another embodiment of the invention. As shown in Fig. 44, the sheet member 10c may have the configuration in which the pattern layer 15, a storage layer 208, the reflection area forming layer 12 are overlaid in this order from the electromagnetic wave incident side. The configuration of the pattern layer 15 and the reflection area forming layer 12 is similar to that described above. Furthermore, as described above, the storage layer 208 is a layer made of a non-conductive dielectric layer and/or magnetic layer. Also with this sort of configuration, a similar effect can be obtained. In the embodiment in Fig. 44, constituent elements corresponding to those in Fig. 1 are denoted by the same numerals. In this embodiment, the storage layer 208 is realized as the storage layers 14 and 13 or the like described above.

[0221] Furthermore, in the configuration of the foregoing embodiments, each of the storage layers 14, 13, 20, and 208 may be multiple layers. In the configuration of the embodiments, the layers 12 to 16, 20, and 208 may be overlaid via an adhesive layer and a support member (PET film, etc.). In this sort of configuration, either one of a dielectric material and a magnetic material may be mixed to an adhesive layer disposed between the layers, in order to obtain a storage effect. In particular, a region in the vicinity of the reflection area forming layer 12 has an intensive magnetic field, and thus it is effective to dispose a layer made of a magnetic material or a layer to which a magnetic material is mixed.

[0222] As another embodiment of the invention, the sheet member may not include the reflection area forming layer 12 in the foregoing embodiments, and this sort of sheet member not including the reflection area forming layer 12 may be disposed on a face of the communication jamming member 57 having electromagnetic wave blocking properties at a surface portion of the second storage layer 13 or the storage layer 208 on the side (the lower side in Figs. 1, 42, 43, and 44) that is opposite to the electromagnetic wave incident side (the upper side in Figs. 1, 42, 43, and 44). The configuration of the communication jamming member 57 may be similar to that of, for example, the reflection area forming layer 12, and may be realized as, for example, a metal plate or the like. In this case, an effect similar to that in a case where the reflection area forming layer 12 is disposed is obtained.

[0223] Although the invention was described mainly in the application as a wireless tag. However, the invention can be added to or integrally formed with an antenna member, and an effect of improving communication can be obtained by eliminating the influence of a communication jamming member to the extent possible, regardless of the application as a tag, a reader, a reader/writer, as long as the apparatus is a data carrier apparatus that is used for wireless communication.

[0224] Hereinafter, the configuration of examples and comparative examples and results obtained by evaluating the performance will be described. Although specific examples of the invention are described, the invention is not limited to this.

[0225] Table 1 lists the configuration and evaluation results of Examples 1 to 6 and Comparative Examples 1 and 2. Table 1 shows presence or absence of the sheet member, the pattern shape, the thickness of the sheet member, and whether or not communication is possible (communicable or not).

Table 1

	Presence or absence of sheet member	Pattern shape	Sheet thickness (mm)	Communicable or not
Ex. 1	Present	Fig. 19	3.0	Able
Ex. 2	Present	Fig. 28	3.0	Able
Ex. 3	Present	Fig. 25	3.0	Able
Ex. 4	Present	Fig. 3	3.0	Able
Ex. 5	Present	Fig. 3	2.7	Able

EP 2 096 711 A1

(continued)

	Presence or absence of sheet member	Pattern shape	Sheet thickness (mm)	Communicable or not	
5	Ex. 6	Present	Fig. 3	2.1	Able
	Com.Ex. 1	Absent	-	-	Disable
	Com.Ex. 2	Absent	-	2.0	Disable
10	Able: Communication distance 5 cm or longer Disable: Communication distance 5 cm or shorter				

[0226] Table 2 lists the configuration of the first, and the second storage layers 13 and 14 in Examples 1 to 6. The first storage layer 13 is set to a storage layer, and the second storage layer 14 is set to a dielectric layer. Table 2 shows the thickness of the first and the second storage layers 13 and 14, the real number part ϵ' and the imaginary number part ϵ'' of the complex relative dielectric constant, and the real number part μ' and the imaginary number part μ'' of the complex relative magnetic permeability.

Table 2

Ex.	Related figure (Pattern shape)	Layer name	Thickness	Material	ϵ'	ϵ''	μ'	μ''
1	Fig. 19	First storage layer	0.5 mm	SBS	13.6	1.3	1.4	0.5
		Second storage layer	2.3 mm	SBS	3.5	0.0	1.0	0.0
2	Fig. 28	First storage layer	0.3 mm	PVC	21.6	1.0	1.2	0.3
		Second storage layer	1.8 mm	PVC	4.0	0.1	1.0	0.0
3	Fig. 25	First storage layer	0.5 mm	SBS	15.6	0.6	1.3	0.5
		Second storage layer	2.0 mm	SBS	4.6	0.1	1.0	0.0
4	Fig. 3	First storage layer	1.0 mm	SBS	12.3	0.7	1.3	0.5
		Second storage layer	1.75 mm	SBS	4.6	0.1	1.0	0.0
5	Fig. 3	First storage layer	0.5 mm	SBS	15.6	0.6	1.3	0.5
		Second storage layer	2.0 mm	SBS	4.6	0.1	1.0	0.0
6	Fig. 3	Second storage layer	0.4mm	PVC	25.8	1.3	1.2	0.3
		Second storage layer	1.7 mm	PVC	3.5	0.0	1.0	0.0

[0227] As a performance evaluation, a communication test between a reader writer 111 and a tag was performed. Figs. 45 and 46 are schematic views showing the manner of the communication test. In examples, the tag 50 having the sheet member 10 was attached to a surface on one side in the thickness direction of a metal plate 110 that was a plate made of stainless steel. In comparative examples, the tag main body 54 was directly attached to a surface on one side in the thickness direction of the same metal plate 110. One surface of the metal plate 110 was selected to be sufficiently larger than a surface on one side in the thickness direction of the tag 50 and the tag main body 54, and to be a square in which one side was 150 mm. The tag 50 or the tag main body 54 was attached to the center portion on one surface of the metal plate 110. In the communication test, in a case where communication was possible, 'Able' was shown in the field indicating whether or not communication is possible in Table 1, and in a case where communication was impossible, 'Disable' was shown in the field indicating whether or not communication is possible in Table 1.

[0228] Wireless communication was performed using the reader writer 111 facing the tag main body 54, and a test was performed to check whether or not communication was possible. A distance L between the reader writer 111 and the tag main body 54 was set to the minimum distance (minimum distance required) L that is required for wireless communication between the tag main body 54 and the reader writer 111 in actual use. The frequency of electromagnetic waves used for wireless communication is in a 2.4 GHz band. Furthermore, air is interposed between the reader writer 111 and the tag main body 54.

(Example 1)

[0229] As the pattern layer 15 and the reflection area forming layer 12, aluminum-evaporated polyethylene terephthalate (polyethylene terephthalate: abbreviated to PET) having a thickness of 100 μm was used. The layer thickness of the aluminum layer in the pattern layer 15 and the reflection area forming layer 12 is 100 μm . The pattern layer 15 was produced by evaporating aluminum on PET to form an aluminum layer, and etching this aluminum layer to form a pattern shape shown in Fig. 19. The first storage layer 14 was produced using a method in which 100 parts by weight of SBS (styrene/butadiene/styrene copolymer) resin, 35 parts by weight of carbon black as a dielectric material, 205 parts by weight of ferrite as a magnetic material, and a dispersant (no magnetic member was used) were mixed, kneaded, and formed into a sheet having a thickness of 1 mm by extrusion molding. The second storage layer 13 was produced as a sheet having a thickness of 1.75 mm in which red phosphorus and magnesium hydroxide were kneaded with SBS for providing flame resistance. The attachment layer 11 had a thickness of 0.15 mm, and was made of an acrylic copolymer resin. The pattern layer 15, the first storage layer 14, the second storage layer 13, and the reflection area forming layer 12 were overlaid via an adhesive in this order, and the attachment layer 11 was overlaid on the reflection area forming layer 12. The layers were cut into 20 mm x 80 mm pieces, and thus sheet member 10 in the shape of a rectangular solid having a total thickness of 3 mm was produced. When the x direction of the conductive pattern portions 22 of the pattern layer 15 is set to the longer-side direction, and the y direction is set to the shorter-side direction, the rectangular pattern shapes 31a are arranged in the longer-side direction so that each of the centroids matches the center in shorter-side direction, and part of the radial pattern shapes 40a is arranged around the rectangular pattern shapes 31a. The produced sheet member 10 and the tag main body 54 were attached together to produce the tag 50.

[0230] Regarding the conductive pattern portions 22 of the pattern layer 15, $a1x = a1y = 2.5$ mm, $a2x = a2y = 16$ mm, $c1x = c1y = 1.0$ mm, $c2x = c2y = 1.0$ mm, $b1x = b1y = 12.5$ mm, and $c1x = c1y = 1.0$ mm.

(Example 2)

[0231] As the pattern layer 15 and the reflection area forming layer 12, aluminum-evaporated polyethylene terephthalate (PET) having a thickness of 100 μm was used. The layer thickness of the aluminum layer in the pattern layer 15 and the reflection area forming layer 12 is 0.05 μm . The pattern layer 15 was produced by evaporating aluminum on PET to form an aluminum layer, and etching this aluminum layer to form a pattern shape shown in Fig. 28. The first storage layer 14 was produced using a method in which 100 parts by weight of PVC (KANEKA CORPORATION, KS1700) resin, 80 parts by weight of DOP [dioctyl phthalate (phthalic acid di-2-ethylhexyl) 1,2-benzenedicarboxylic acid bis(2-ethylhexyl)ester], 43 parts by weight of graphite as a dielectric material, 125 parts by weight of ferrite as a magnetic material, and calcium carbonate were mixed, kneaded, and formed into a sheet having a thickness of 0.3 mm by extrusion molding. The second storage layer 13 was produced as a sheet having a thickness, of 1.8 mm in which red phosphorus and magnesium hydroxide were kneaded with SBS for providing flame resistance. The attachment layer 11 had a thickness of 0.15 mm, and was made of an acrylic copolymer resin. The pattern layer 15, the first storage layer 14, the second storage layer 13, and the reflection area forming layer 12 were overlaid via an adhesive in this order, and the attachment layer 11 was overlaid on the reflection area forming layer 12. The layers were cut into 20 mm x 80 mm pieces, and thus sheet member 10 in the shape of a rectangular solid having a total thickness of 2.1 mm was produced.

[0232] Regarding the conductive pattern portions 22 of the pattern layer 15, $b1x = b1y = 21.0$ mm, $R2a = 7.0$ mm, $R2b = 4.0$ mm, and $d1x = d1y = 1.5$ mm. When the x direction of the conductive pattern portions 22 of the pattern layer 15 is set to the longer-side direction, and the y direction is set to the shorter-side direction, the rectangular pattern shapes 31a are arranged in the longer-side direction so that each of the centroids matches the center in shorter-side direction.

(Example 3)

[0233] The pattern layer 15 was formed into a pattern shape shown in Fig. 22, and other procedures in the method were the same as those in Example 1.

[0234] Regarding the conductive pattern portions 22 of the pattern layer 15, $b1x = b1y = 21.0$ mm, and $d1x = d1y = 1.5$ mm. When the x direction of the conductive pattern portions 22 of the pattern layer 15 is set to the longer-side direction, and the y direction is set to the shorter-side direction, the rectangular pattern shapes 31a are arranged in the longer-side direction so that each of the centroids matches the center in shorter-side direction.

(Example 4)

[0235] The pattern layer 15 was formed into a pattern shape shown in Fig. 3, and other procedures in the method were the same as those in Example 1.

[0236] Regarding the conductive pattern portions 22 of the pattern layer 15, $a1x = a1y = 1.0$ mm, $a2x = a2y = 17.5$

EP 2 096 711 A1

mm, $a3x = a3y = 7.5$ mm, $c1x = c1y = 1.5$ mm, $c2x = c2y = 7.0$ mm, $b1x = b1y = 20.5$ mm, $c1x = c1y = 1.5$ mm, $R1 = 7.5$ mm, and $R2 = 7.0$ mm. When the x direction of the conductive pattern portions 22 of the pattern layer 15 is set to the longer-side direction, and the y direction is set to the shorter-side direction, the rectangular pattern shapes 31a are arranged in the longer-side direction so that each of the centroids matches the center in shorter-side direction, and part of the radial pattern shapes 40a is arranged around the rectangular pattern shapes 31a.

(Example 5)

[0237] As the pattern layer 15 and the reflection area forming layer 12, aluminum-evaporated polyethylene terephthalate (PET) having a thickness of 100 μm was used. The layer thickness of the aluminum layer in the pattern layer 15 and the reflection area forming layer 12 is 0.05 μm . The pattern layer 15 was produced by evaporating aluminum on PET to form an aluminum layer, and etching this aluminum layer to form a pattern shape shown in Fig. 3. The first storage layer 14 was produced using a method in which 100 parts by weight of SBS resin, 55 parts by weight of graphite as a dielectric material, 213 parts by weight of ferrite as a magnetic material, and a dispersant were mixed, kneaded, and formed into a sheet having a thickness of 0.5 mm by extrusion molding. The second storage layer 13 was produced as a sheet having a thickness of 2.0 mm in which red phosphorus and magnesium hydroxide were kneaded with SBS for providing flame resistance. The attachment layer 11 had a thickness of 0.15 mm, and was made of an acrylic copolymer resin. The pattern layer 15, the first storage layer 14, the second storage layer 13, and the reflection area forming layer 12 were overlaid via an adhesive in this order, and the attachment layer 11 was overlaid on the reflection area forming layer 12. The layers were cut into 20 mm \times 80 mm pieces, and thus sheet member 10 in the shape of a rectangular solid having a total thickness of 2.7 mm was produced.

[0238] The size of the conductive pattern portions 22 of the pattern layer 15 is similar to that in Example 4.

(Example 6)

[0239] As the pattern layer 15 and the reflection area forming layer 12, aluminum-evaporated polyethylene terephthalate (PET) having a thickness of 100 μm was used. The layer thickness of the aluminum layer in the pattern layer 15 and the reflection area forming layer 12 is 0.05 μm . The pattern layer 15 was produced by evaporating aluminum on PET to form an aluminum layer, and etching this aluminum layer to form a pattern shape shown in Fig. 3. The first storage layer 14 was produced using a method in which 100 parts by weight of PVC resin, 80 parts by weight of DOP, 48 parts by weight of graphite as a dielectric material, 130 parts by weight of ferrite as a magnetic material, and calcium carbonate as a filler were mixed, kneaded, and formed into a sheet having a thickness of 0.4 mm by extrusion molding. The second storage layer 13 was produced as a sheet having a thickness of 1.7 mm in which red phosphorus and magnesium hydroxide were kneaded with SBS for providing flame resistance. The attachment layer 11 had a thickness of 0.15 mm, and was made of an acrylic copolymer resin. The pattern layer 15, the first storage layer 14, the second storage layer 13, and the reflection area forming layer 12 were overlaid via an adhesive in this order, and the attachment layer 11 was overlaid on the reflection area forming layer 12. The layers were cut into 20 mm \times 80 mm pieces, and thus sheet member 10 in the shape of a rectangular solid having a total thickness of 2.1 mm was produced.

[0240] The size of the conductive pattern portions 22 of the pattern layer 15 is similar to that in Example 4.

(Comparative Example 1)

[0241] A communication test was performed in a state where the tag main body 54 as in Examples 1 to 6 was directly attached to the metal plate 110.

[0242] As seen from the test result shown in Table 1, communication was not possible between the tag main body 54 and the reader/writer 111 in the comparative examples, but communication between the tag 50 and the reader/writer 111 was possible in all of Examples 1 to 7. In Examples 1 to 7, it was possible to suitably perform wireless communication even in the vicinity of the metal plate 110 that is the communication jamming member 57, and to suppress a decrease in the communication distance when the tag was attached to the metal plate 110.

(Comparative Example 2)

[0243] A communication test was performed in a state where a magnetic sheet made of rubber ferrite (2 mm thickness) cut into a 20 mm \times 80 mm piece was interposed between the tag main body 54 and the metal plate 110. The effect of improving communication was low, and was clearly inferior to that of the sheet member 10 of the invention.

(Example 7)

[0244] The pattern shape is substantially the same as that shown in Figs. 40 and 41, the radial pattern portions 30 and the substantially rectangular patterns 31 have different curvatures, and the gap c1 between the two pattern portions 30 and 31 is continuously changed. The size of the conductive pattern portions 22 was set so that $a1x = a1y = 1.0$ mm, $a2x = a2y = 20.0$ mm, $b1x = b1y = 25$ mm, $c2x = c2y = 7.0$ mm, and $c1 = 0.5$ mm or more and 2.5 mm or less. In the substantially triangular portion 22 in the radial pattern portion 30, the radius of curvature R1 was set to 6.5 mm. In the substantially rectangular patterns 31, the radius of curvature R2 of the corners was set to 10.5 mm. The gap c1 between the radial pattern portion 30 and the substantially rectangular pattern 31 is continuously changed so that the gap becomes larger at the middle portion than the end portions in a direction in which the gap between the pattern portions 30 and 31 extends.

[0245] As the first storage layer 14, a plasticizer, a dispersant, calcium carbonate, and the like were added to 100 (phr) of chlorinated polyethylene (Showa Denko K.K., ELASLEN301NA) and 800 (phr) of carbonyliron (EW-1 manufactured by BASF). As the second storage layer 13, a plasticizer, a dispersant, and the like were added to 100 (phr) of chlorinated polyethylene that is the same as that used in the first storage layer 14 and 16 (phr) of graphite. The configuration was applied in which the pattern layer 15 (aluminum-evaporated PET film), the first storage layer 14 (2.1 mm), the second storage layer 13 (2.5 mm), and the reflection area forming layer (aluminum-evaporated PET film) were overlaid. The material constants in a 950 MHz band were set so that, in the first storage layer 14, $\epsilon' = 19.0$, $\epsilon'' = 0.90$ ($\tan\delta\epsilon = 0.047$), $\mu' = 5.33$, and $\mu'' = 1.43$ ($\tan\delta\mu = 0.268$), and in the second storage layer 13, $\epsilon' = 7.9$, $\epsilon'' = 0.13$ ($\tan\delta\epsilon = 0.017$), $\mu' = 1$, and $\mu'' = 0$, in order to suppress the loss. As the sheet member 10, a sheet for a UHF band having a thickness of approximately 4.6 mm was used.

[0246] Fig. 47 is a graph showing a calculation result obtained with a simulation of the reflection loss of the sheet member 10 in Example 7. In Fig. 47, the horizontal axis represents the frequency, and the vertical axis represents the reflection loss. The reflection loss amount in the invention is calculated using a computer simulation as described above. The pattern structure of this example was set so that, as described above, the radius of curvature of the corners was changed between the adjacent conductive pattern portions 22 and the gap between the conductive pattern portions 22 was continuously changed, and thus the resonance (frequency and Q) was adjusted.

[0247] The sheet member 10 of Example 7 was cut into a piece having a size that was slightly larger than the tag main body 54 so that the tag main body 54 was disposed on the radial pattern portion 30, a middle-range tag for an UHF band (ALIEN2004, 89 mm × 19 mm) manufactured by ALIEN was overlaid on the sheet member 10, and a reading test was performed using a reader (ALR-7610-75L, linear polarization) manufactured by ALIEN. In a case where the middle-range tag was evaluated in a free space, the communication distance was 2800 mm. Table 3 shows the results (results obtained by measuring the communication distance) of the reading test. Table 3 also shows results obtained as Comparative Examples 3 and 4 by performing a similar reading test in which foamed polystyrene, which is a foam, was used instead of the sheet member 10. Table 3 shows the thickness of the sheet member 10 (sheet thickness), the communication distance, and the ratio of communication distance with respect to a free space. In this reading test, an aluminum plate was used as a communication jamming member, and the sheet member 10 or a foam was attached to the aluminum plate. Accordingly, the sheet thickness is the same as the distance (gap size) from the aluminum plate to the tag main body 54.

Table 3

Configuration	Ex. 7	Com.Ex. 3	Com.Ex. 4
		Foamed polystyrene	
Sheet thickness (gap size) (mm)	5.1	5	10
Communication distance (mm)	2130	590	960
Ratio of communication distance with respect to free space (%)	76	21	35

[0248] In a case where Comparative the sheet member 10 having a thickness of approximately 5 mm of Example 7 was used, the communication distance was 2130 mm, that is, the communication distance that was approximately 76% of that in the case of a free space was obtained. In a case where a reading test was performed using a foam for comparison, the communication distance was 21% of that in the case of a free space. Thus, it was clear that the sheet member 10 of the invention has a significant effect of improving communication distance.

(Example 8)

[0249] Fig. 48 is a cross-sectional view showing the sheet member 10 of Example 8. Fig. 49 is a plan view showing the tag main body 54 that is attached to the sheet member 10 of Example 8. Fig. 50 is a plan view showing the pattern layer 15 constituting the sheet member 10 of Example 8. Fig. 48 shows a state in which the tag main body 54 is attached. The sheet member 10 of Example 8 has a configuration in which the reflection area forming layer 12, the second storage layer 13, the first storage layer 14, the film layer/adhesive layer 207, and the pattern layer 15 are overlaid in this order. The pattern layer 15 includes the conductive pattern portions 22 and the spacer (base) 21. The reflection area forming layer 12 and the pattern layer 15 are made of an aluminum-evaporated PET film. The pattern layer 15 is disposed so that the conductive pattern portions 22 oppose the film layer/adhesive layer 207. It should be noted that the film layer/adhesive layer, the spacer (base), and the like are also the storage layers in the invention.

[0250] In this example, the conductive pattern portions 22 had the pattern shape shown in Fig. 25, and were cut into a piece having a size in which four rectangular pattern shapes 31a in the shape of a square with a side length $W1 = 45$ mm were arranged with a gap $W2 = 1$ mm interposed therebetween. With the configuration shown in Figs. 48 to 50, an effect of improving metal-compatible communication was calculated for the tag main body 54 attached to the sheet member 10. The thickness including the experimentally produced tag main body 54 and the sheet member 10 was approximately 3 mm, that is, the thickness was made smaller. The experimentally produced tag main body 54 is substantially in the shape of a rectangle (length 147 mm, width 10 mm) as shown in Fig. 49, and is a UHF band tag in which the impedance of the tag chip functioning as the IC 52 is set to $30-j250 (\Omega)$ in a 950 MHz band. The tag main body 54 is disposed to be overlaid at the center portion of the conductive pattern portions 22 including four rectangular pattern shapes 31a so that the longer-side direction matches the direction in which the four rectangular pattern shapes 31a are arranged.

[0251] Table 4 shows the material constants of materials constituting the sheet member 10 of Example 8. Table 4 shows the layer thickness, the real number part ϵ' of the complex relative dielectric constant, the dielectric loss $\tan\delta (\epsilon)$, the real number part μ' of the complex relative magnetic permeability, the magnetic loss $\tan\delta (\mu)$, and the electrical conductivity σ of the spacer (base) 21, the film layer/adhesive layer 207, the first storage layer 14, and the second storage layer 13.

Table 4

Layer name	Thickness (mm)	ϵ'	$\tan\delta (\epsilon)$	μ'	$\tan\delta (\mu)$	Electrical conductivity σ
Spacer (base)	1	3	0.01	1	0	0
Film layer/ Adhesive layer	0.15	3	0.01	1	0	0
First storage layer	0.5	15.1	0.049	4.55	0.24	0.039
Second storage layer	1.5	3	0.01	1	0	0

[0252] Table 5 shows results obtained by evaluating the antenna properties of the tag main body 54 in a case where the sheet member 10 of Example 8 was used. Table 5 shows the measured reflection coefficient S11, the real part of the real number part Z11 of impedance, the imaginary part of the imaginary number part Z11 of impedance, and the absolute gain in electromagnetic waves in a 950 MHz band, and relative comparison with a case in which the tag main body 54 was used in a free space. As the relative comparison with a case in which the tag main body 54 was used in a free space, the electricity supply to the antenna element 51, the radiation from the antenna element 51, the total, and the presumed communication distance are shown. In Table 5, 'electricity supply' represents the degree of matching from a chip to an antenna element. It is indicated that, as the value is larger, matching is established more suitably. The comparison is shown taking a free space as 1. Furthermore, 'radiation' represents the radiated power in a case where electric power of the same size is supplied from the chip to the antenna element after establishing matching. Also, the comparison is shown taking a free space as 1. Furthermore, 'total' represents the radiated power in a case where electric power of the same size is supplied from the chip to the antenna element without establishing matching. Also, the comparison is shown taking a free space as 1. The comparison of 'total' represents comparison of the antenna properties. Table 5 also shows, as a comparative example, the antenna properties in a case where the tag main body 54 is disposed so as to be spaced away from the communication jamming member 57 by 3.15 mm.

[0253] Formula (3) represents a basic presumption formula for the presumed communication distance.

EP 2 096 711 A1

$$\text{Communication distance [m]} = \sqrt{\frac{\text{Transmission power EIRP [W]} \times \text{Tag antennagain [Antilog]} \times \text{Polarization loss [Antilog]}}{(4\pi)^2 \times \text{Tag minimum required power [W]}}} \times \text{Wavelength [m]} \dots (3)$$

[0254] The distance was presumed based on the conditions that the transmission power of the tag is constant, the polarization loss is not taken into consideration, and the distance is proportional to the square root ($\sqrt{\quad}$) of the antenna gain (antilogarithm) of the tag. Furthermore, the antenna gain was taken to be similar to the actual gain (gain including matching loss and material loss).

Table 5

	950 MHz				Comparison with free space			
	S11 (dB)	Real part of Z11	imaginary part of Z11	Absolute gain (dBi)	Electricity supply	Radiation	total	Presumed communication distance
Free space	-11.827	24.309	236.863	2.290	1.000	1.000	1.000	1.000
Gap (3.15 mm)	0.0750078	32.016	-219.603	7,052	0.018	2.994	0.055	0.234
Ex. 8	-11.0416	19.2147	258.976	-3.532	0.986	0.262	0.258	0.508

[0255] As a result, as shown in Table 5, the presumed communication distance in a case where the sheet member 10 of the example is used is 51% of that in the case of a free space, and the distance in the comparative example in which a space corresponding to a thickness (3.15 mm) is provided from the communication jamming member 57 is approximately 23% of that in the case of a free space, that is, the sheet member 10 of the example exhibited the communication distance that is twice or more than that in the comparative example. Thus, the possibility has been found that the sheet member 10 of the example can be used as a metal-compatible thin antenna member for a UHF band.

[0256] Table 6 shows the radiation efficiency of the experimentally produced tag main body 54. Here, radiation efficiency $\eta = 10^{(\text{gain} - \text{directional gain})/10}$. Directional gain is a gain not including metal loss or the like. Gain (usually, simple indication 'gain' refers to this gain) can be regarded as 'so-called true gain' including loss. When the radiation resistance of the antenna is taken as Rrad, and the loss resistance is taken as Rloss, radiation efficiency $\eta = Rrad / (Rrad + Rloss)$. Rrad corresponds to the resistance of the input impedance of a no-loss antenna. In the tag main body 54 used in Example 8, the directional gain was 7.44 dBi, the gain (absolute gain) was -3.53 dBi, and the radiation efficiency was approximately 8%.

Table 6

Directional gain (dBi)	Absolute gain (dBi)	Radiation efficiency
7.440	-3.532	7.99%

[0257] The invention may be embodied in other specific forms without departing from the spirit or essential characteristics thereof. The present embodiments are therefore to be considered in all respects as illustrative and not restrictive, the scope of the invention being indicated by the appended claims rather than by the foregoing description and all changes which come within the meaning and the range of equivalency of the claims are therefore intended to be embraced therein.

Industrial Applicability

[0258] According to the invention, the sheet member for improving communication is disposed between the antenna element and the communication jamming member, and the pattern layer is disposed in the vicinity of the antenna element in an electrically insulated state. Thus, electromagnetic coupling is formed between the conductive pattern portion and the antenna element, electromagnetic energy is transferred from the conductive pattern portion to the antenna element,

and electromagnetic energy at the resonance frequency is supplied from the conductive pattern portion to the antenna element. Accordingly, wireless communication can be suitably performed even in the vicinity of a communication jamming member, and sufficient communication distance can be secured.

5 [0259] Furthermore, according to the invention, when the antenna element is disposed in the vicinity of a communication jamming member, the storage layer that collects energy of electromagnetic waves used for wireless communication is disposed between the antenna element and the communication jamming member. Thus, conduction can be prevented, and reactance (L) components and capacitance (C) components can be increased. Furthermore, due to the real number part ϵ' of the complex relative dielectric constant and/or the real number part μ' of the complex relative magnetic permeability, the propagation path of electromagnetic waves that have entered the sheet member can be bent. Moreover, due to a wavelength shortening effect, the sheet member can be made smaller.

10 [0260] Furthermore, according to the invention, the reflection area forming layer forms a reflection area. Thus, even in a small and thin sheet member, the phase of reflected waves from the reflection area can be adjusted, and thus an area having high electric field intensity due to interference between reflected waves from the reflection area and arriving electromagnetic waves can be set on the surface of the sheet member and/or in the vicinity of the antenna element.

15 Furthermore, when the antenna element is disposed in the vicinity of a communication jamming member, a decrease in the input impedance of the antenna element caused by the communication jamming member can be suppressed, and thus wireless communication can be suitably performed even in the vicinity of a communication jamming member.

[0261] Furthermore, in a case where the reflection area forming layer is disposed, communication conditions of the antenna element can be prevented from being changed according to the material (material quality) of each communication jamming member, and thus the communication conditions using the antenna element can be stabilized in any environment.

[0262] Furthermore, according to the invention, with the pattern layer, electromagnetic waves corresponding to the size of each of the conductive pattern portions can be received to cause resonance. Depending on how the size of the conductive pattern portions is determined, electric power obtained by the antenna element from electromagnetic waves used for wireless communication can be increased.

[0263] Furthermore, according to the invention, a plurality of types of conductive pattern portions in which at least one of size and shape is different therebetween have respectively different resonance frequencies, and thus the pattern layer can receive electromagnetic waves at a plurality of frequencies. Furthermore, the electric power obtained by the antenna element from electromagnetic waves used for wireless communication can be reliably increased.

30 [0264] Furthermore, according to the invention, the pattern layer in which the conductive pattern portion continuously disposed in a wide range is formed can increase the gain over frequencies in a wide band. Thus, the sheet member provided therewith can receive electromagnetic waves at frequencies in a wide band or a plurality of frequency bands. Furthermore, the electric power obtained by the antenna element from electromagnetic waves used for wireless communication can be reliably increased.

35 [0265] Furthermore, according to the invention, the conductive pattern portion that receives electromagnetic waves has a substantially polygonal outer shape that is basically in the shape of a polygon, and at least one corner is curved. Thus, an excellent sheet member for improving communication can be realized in which a peak value of the gain is high, and shift of the frequency at which the gain has a peak value according to the direction in which electromagnetic waves are polarized is small.

40 [0266] Furthermore, according to the invention, since the conductive pattern portions having different radii of curvature of the corners are formed, the frequency band of electromagnetic waves that are to be received (hereinafter, may be referred to as a 'reception band') can be changed without lowering a peak value of the gain, compared with a case in which only conductive pattern portions having the same radius of curvature of the corners are formed.

[0267] Furthermore, according to the invention, the gain can be increased compared with a case in which the gap between two adjacent conductive pattern portions is constant.

45 [0268] Furthermore, according to the invention, wireless communication can be suitably performed using electromagnetic waves having a frequency of 300 MHz or higher and 300 GHz or lower.

[0269] Furthermore, according to the invention, the thickness of the sheet member for enabling wireless communication to be suitably performed using electromagnetic waves at a frequency in the range of 300 MHz or higher and 300 GHz or lower can be made as small as possible, and thus the sheet member can be made thinner.

[0270] Furthermore, according to the invention, the thickness of the sheet member for enabling wireless communication to be suitably performed using electromagnetic waves at a frequency included in a high MHz band can be made as small as possible, and thus the sheet member can be made thinner.

55 [0271] Furthermore, according to the invention, the thickness of the sheet member for enabling wireless communication to be suitably performed using electromagnetic waves at a frequency included in a 2.4 GHz band can be made as small as possible, and thus the sheet member can be made thinner.

[0272] Furthermore, according to the invention, the storage layer is made of a material in which one or a plurality of materials selected from the group consisting of ferrite, iron alloy, and iron particles are contained as the magnetic material

in an amount blended of 1 part by weight or more and 1500 parts by weight or less, with respect to 100 parts by weight of an organic polymer. Thus, a sheet member achieving the above-described effect can be suitably realized.

[0273] Furthermore, according to the invention, the sheet member can be flame-resistant. Thus, the sheet member can be suitably used also for the application where flame resistance is required.

5 [0274] Furthermore, according to the invention, at least one surface portion is glutinous or adhesive. Thus, the sheet member can be attached to other articles. Accordingly, the sheet member can be easily used.

[0275] Furthermore, according to the invention, an antenna device can be realized that comprises the sheet member and that can be suitably used for wireless communication in a state where the antenna device is disposed in the vicinity of a communication jamming member.

10 [0276] Furthermore, according to the invention, an electronic information transmitting apparatus can be realized that can suitably perform wireless communication even in a case where the electronic information transmitting apparatus is disposed in the vicinity of a communication jamming member.

15 **Claims**

1. (Amended) A sheet member for improving communication used when performing wireless communication using an antenna element in a vicinity of a communication jamming member, the sheet member being disposed between the antenna element and the communication jamming member, and comprising a pattern layer in which a conductive pattern portion is formed.
2. (Amended) The sheet member for improving communication of claim 1, further comprising a storage layer that is made of a non-conductive dielectric layer and/or magnetic layer and that collects energy of electromagnetic waves used for wireless communication.
- 25 3. (Amended) The sheet member for improving communication of claim 2, wherein a reflection area forming layer that forms a reflection area reflecting electromagnetic waves used for wireless communication is disposed to have the storage layer interposed between the reflection area forming layer and the pattern layer, and to be spaced away from the pattern layer on the opposite side of the antenna element, in the vicinity of a position at which the electrical length from the pattern layer is $((2n-1)/4)\lambda$ (n is a positive integer) when the wavelength of electromagnetic waves used for wireless communication is taken as λ .
- 30 4. (Amended) The sheet member for improving communication of any one of claims 1 to 3, wherein a plurality of conductive pattern portions that are electrically insulated from each other are formed in the pattern layer.
- 35 5. (Amended) The sheet member for improving communication of claim 4, wherein a plurality of types of conductive pattern portions in which at least one of size and shape is different therebetween are formed in the pattern layer.
6. The sheet member for improving communication of any one of claims 1 to 5, wherein a conductive pattern portion that continuously extends over a wide range of the sheet member is formed in the pattern layer.
- 40 7. The sheet member for improving communication of any one of claims 1 to 6, wherein the conductive pattern portion has a substantially polygonal outer shape in which at least one corner is curved.
- 45 8. The sheet member for improving communication of claim 7, wherein a plurality of conductive pattern portions are formed in the pattern layer, and the conductive pattern portions have different radiuses of curvature of corners and are formed in combination.
- 50 9. The sheet member for improving communication of any one of claims 1 to 8, wherein a plurality of conductive pattern portions are formed in the pattern layer, and a gap between two adjacent conductive pattern portions varies depending on the position.
10. The sheet member for improving communication of any one of claims 1 to 9, wherein a frequency of electromagnetic waves used for wireless communication is included in the range of at least 300 MHz and not greater than 300 GHz.
- 55 11. The sheet member for improving communication of claim 10, wherein a total thickness is not greater than 50 mm.
12. The sheet member for improving communication of claim 10, wherein the frequency of electromagnetic waves used

EP 2 096 711 A1

for wireless communication is included in any one of frequency bands in the range of at least 860 MHz band and less than 1,000 MHz band, and a total thickness is not greater than 15 mm.

5 **13.** The sheet member for improving communication of claim 10, wherein the frequency of electromagnetic waves used for wireless communication is included in a 2.4 GHz band, and a total thickness is not greater than 8 mm.

14. The sheet member for improving communication of any one of claims 1 to 13, wherein the storage layer is made of a material in which one or a plurality of materials selected from the group consisting of ferrite, iron alloy, and iron particles are contained as a magnetic material in an amount blended of at least 1 part by weight and not greater than 1500 parts by weight, with respect to 100 parts by weight of an organic polymer.

15. The sheet member for improving communication of any one of claims 1 to 14, wherein the sheet member for improving communication is flame-resistant.

15 **16.** The sheet member for improving communication of any one of claims 1 to 15, wherein at least one surface portion is glutinous or adhesive.

17. An antenna device, comprising:

20 an antenna element that has a resonance frequency matched to a frequency used for wireless communication;
and
the sheet member for improving communication of any one of claims 1 to 16.

18. An electronic information transmitting apparatus comprising the antenna device of claim 17.

25

30

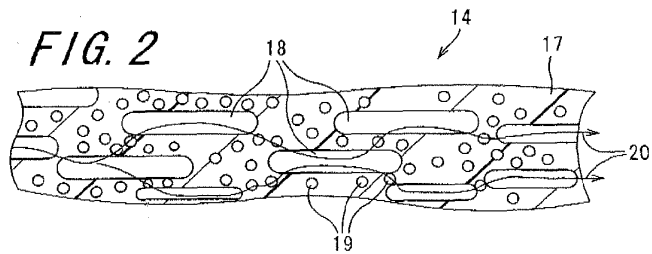
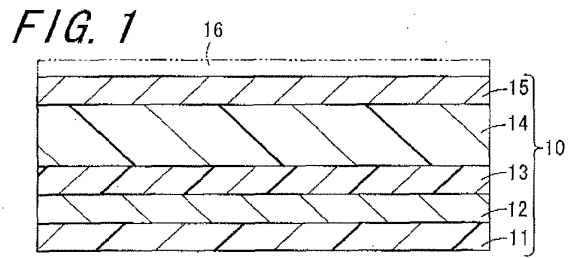
35

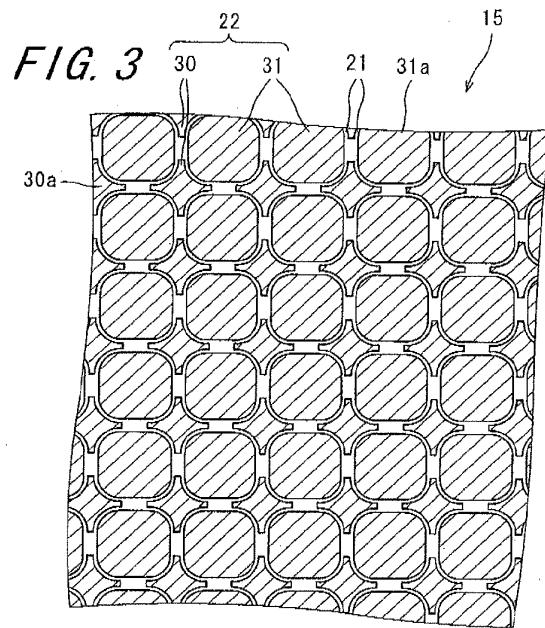
40

45

50

55





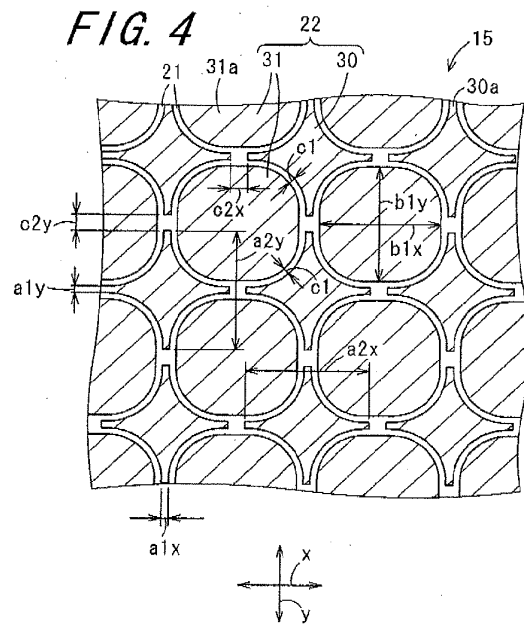
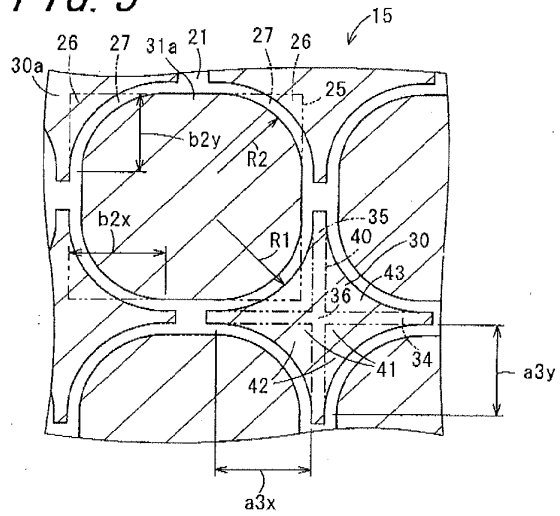


FIG. 5



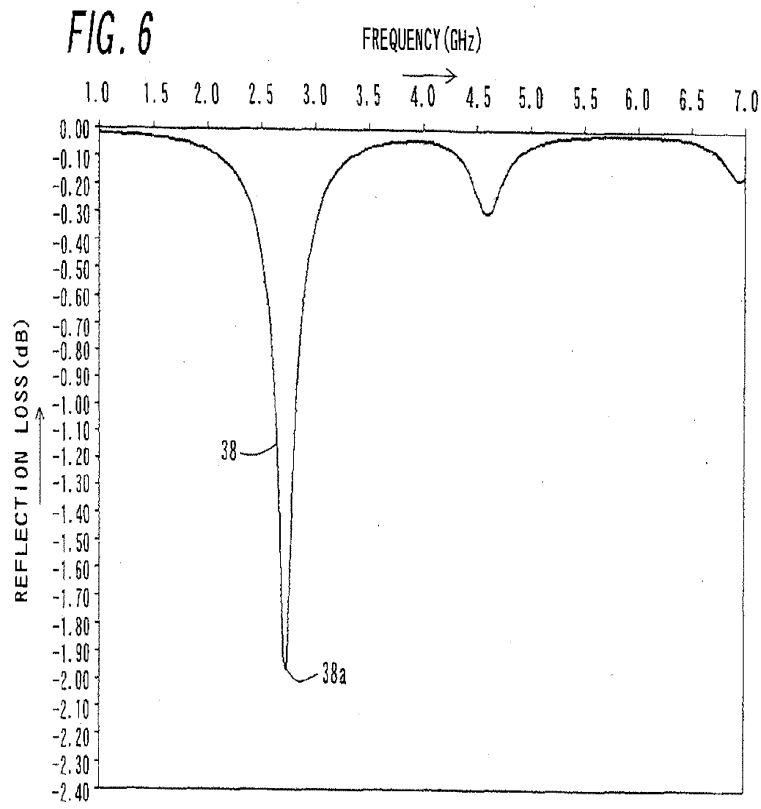
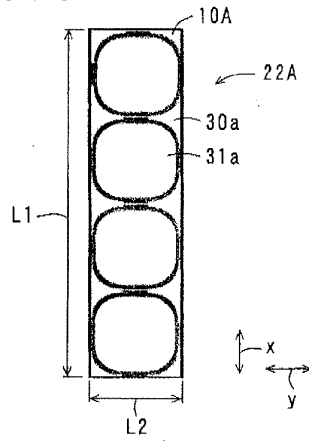
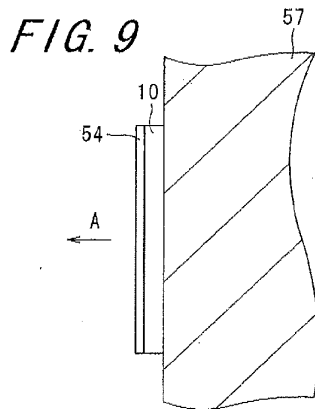
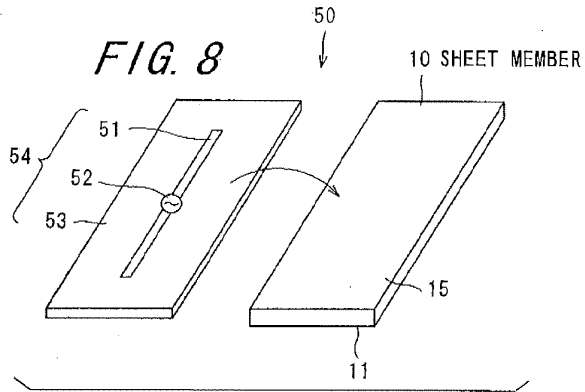


FIG. 7





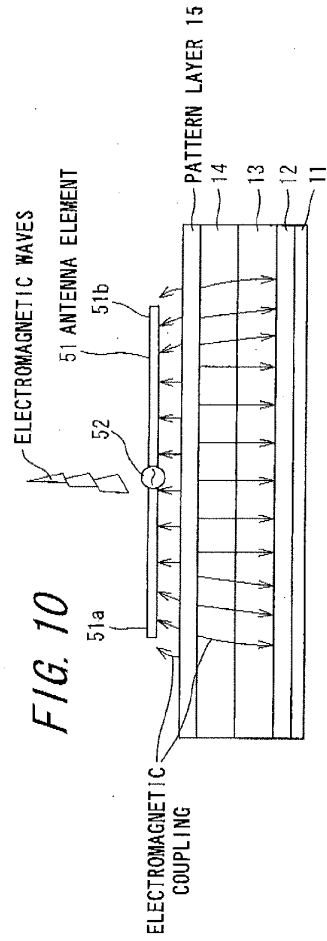
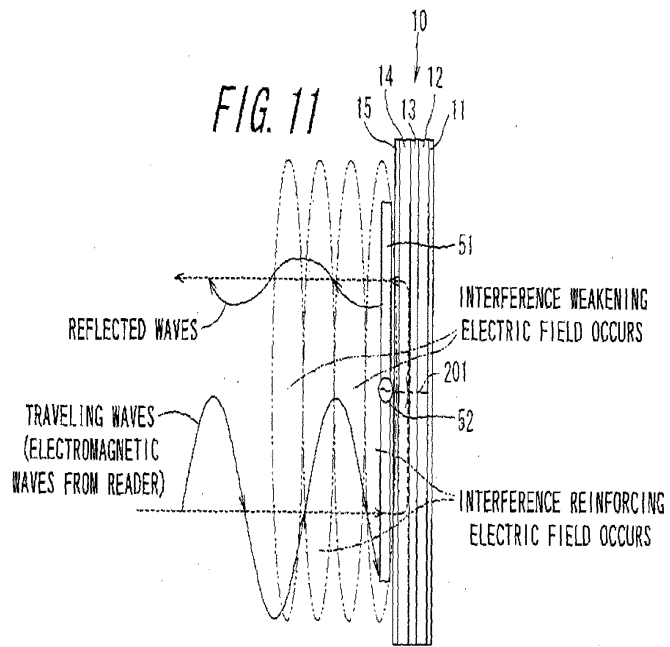


FIG. 10



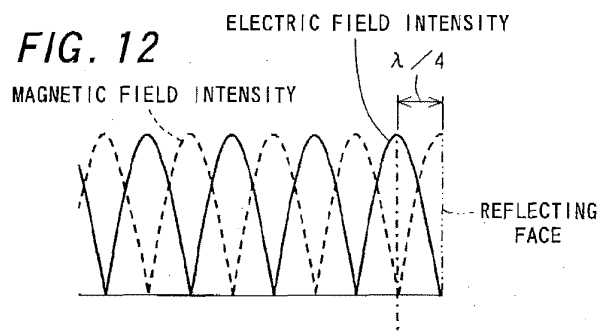
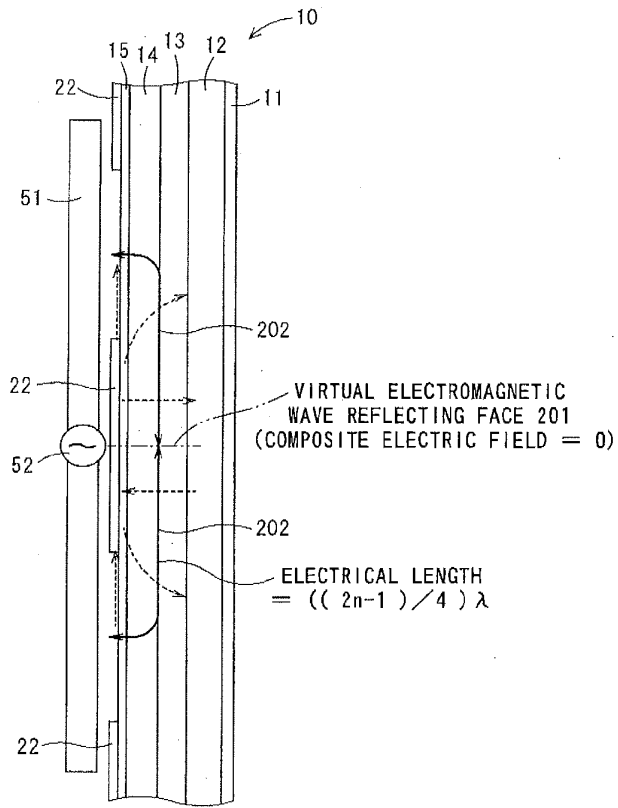


FIG. 13



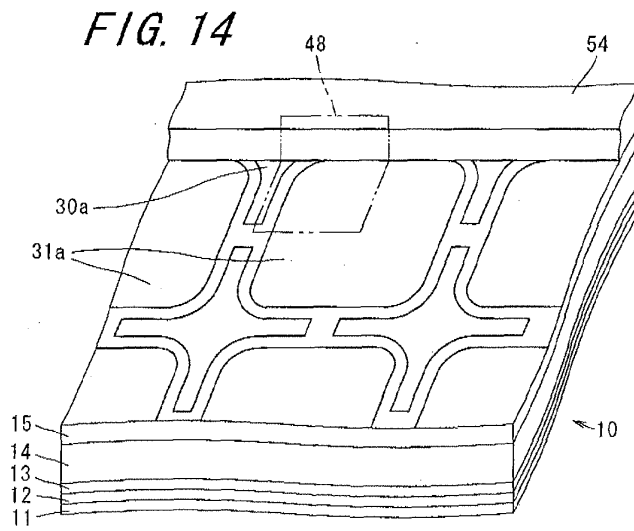


FIG. 15

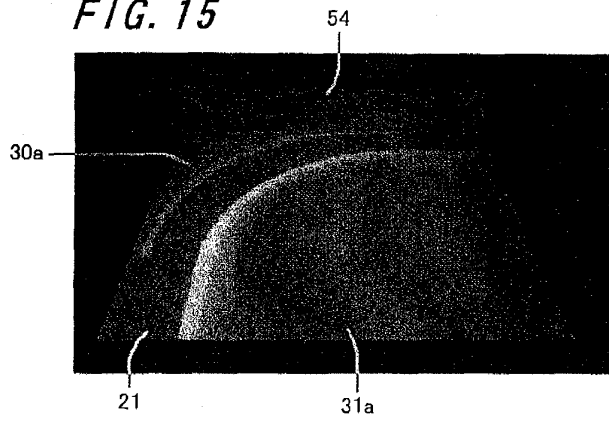
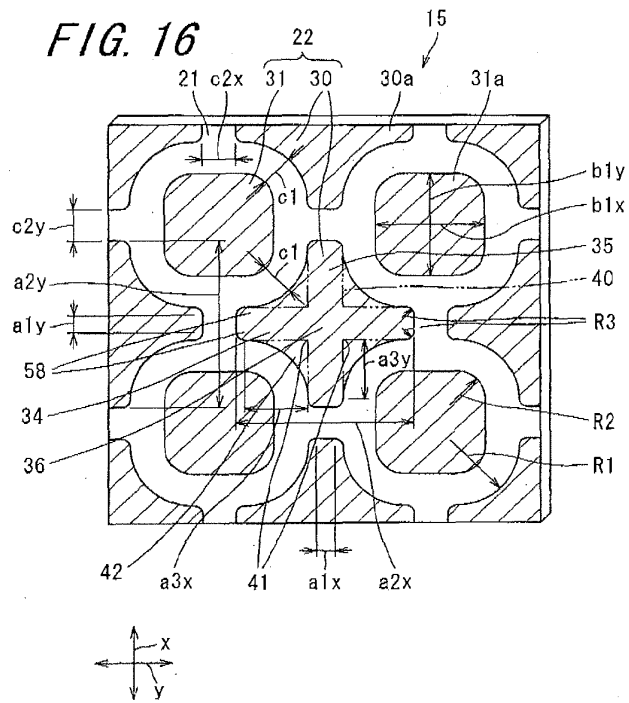
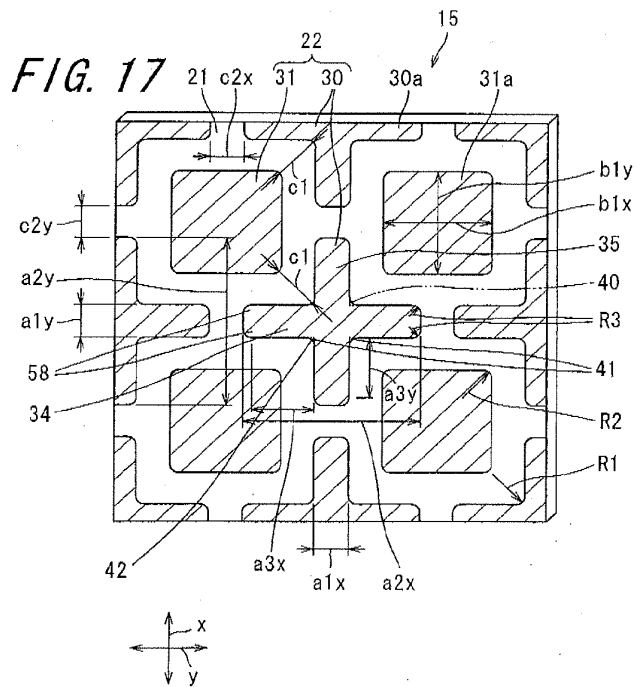
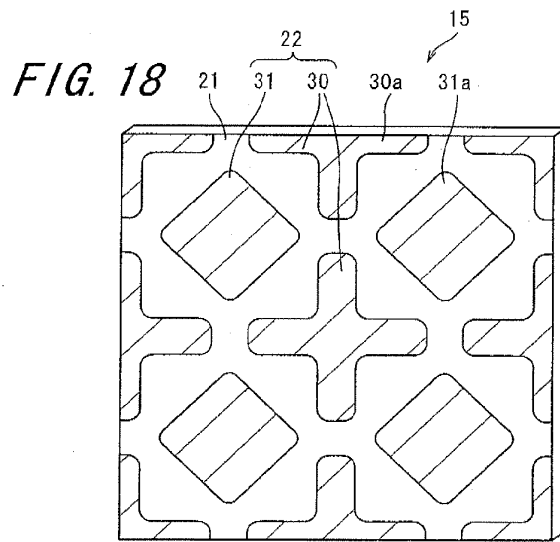
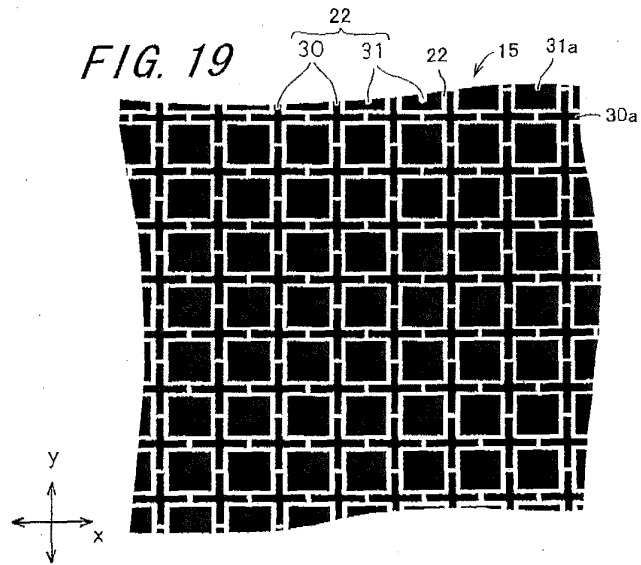


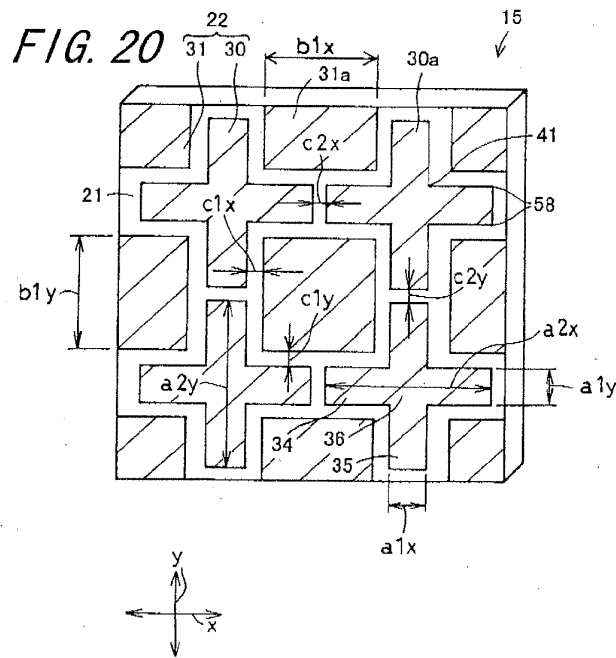
FIG. 16











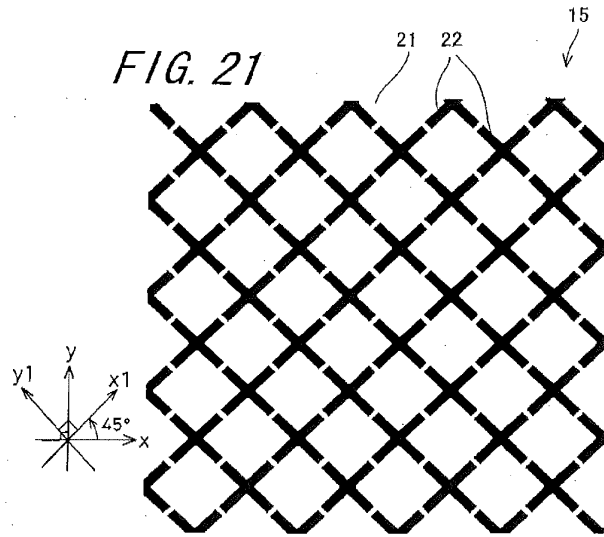


FIG. 22

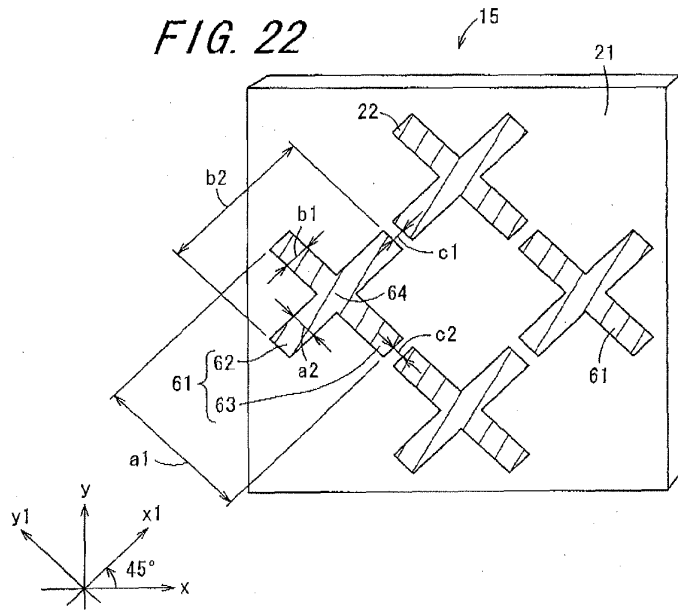
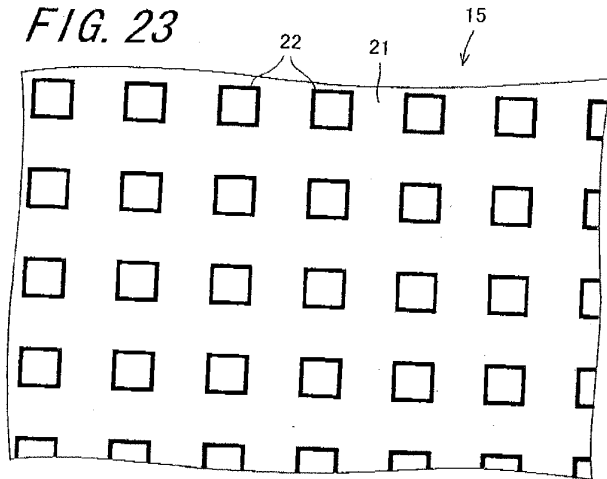


FIG. 23



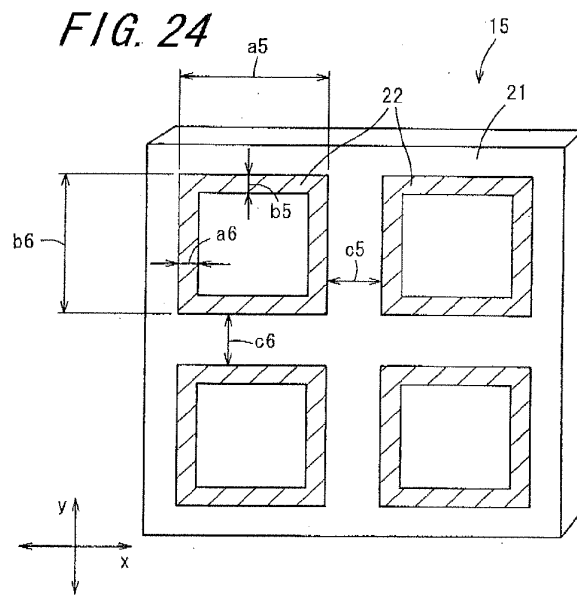
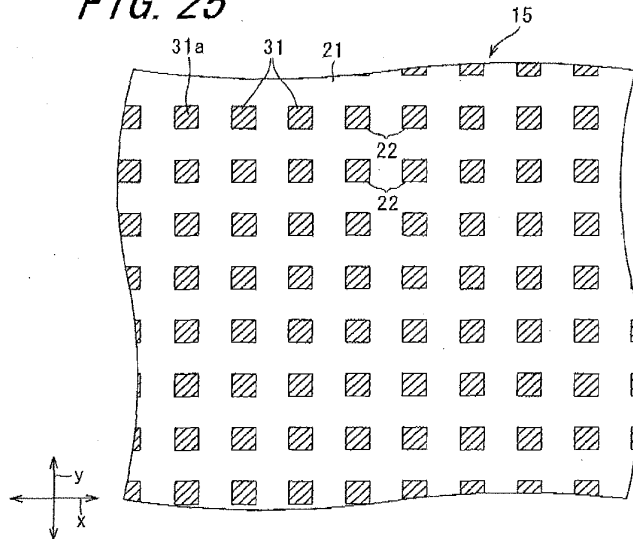
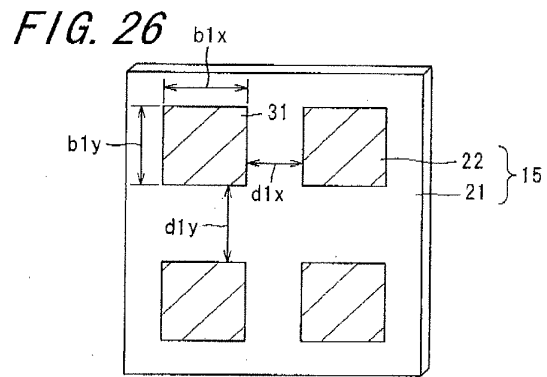
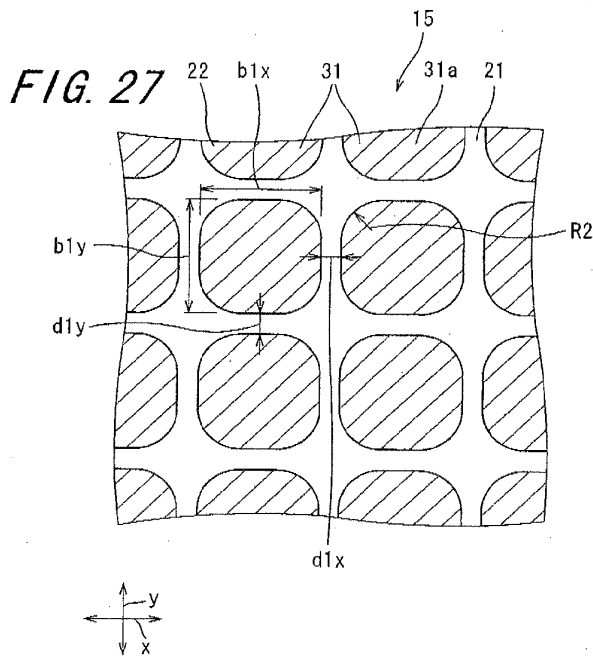
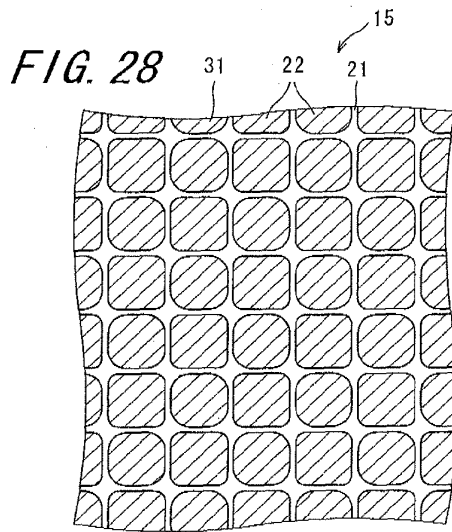


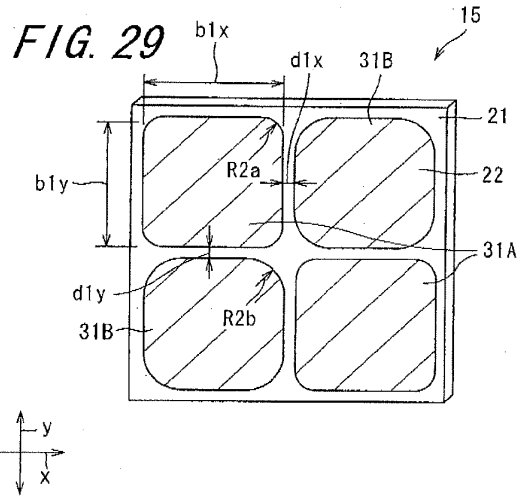
FIG. 25

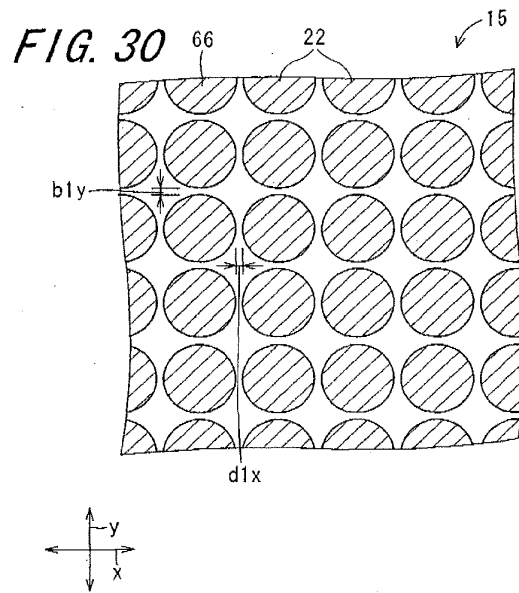


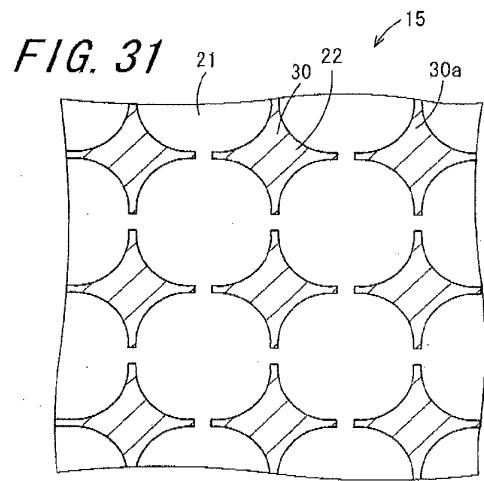


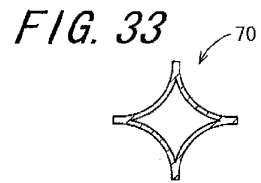
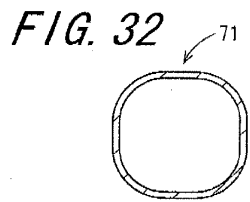


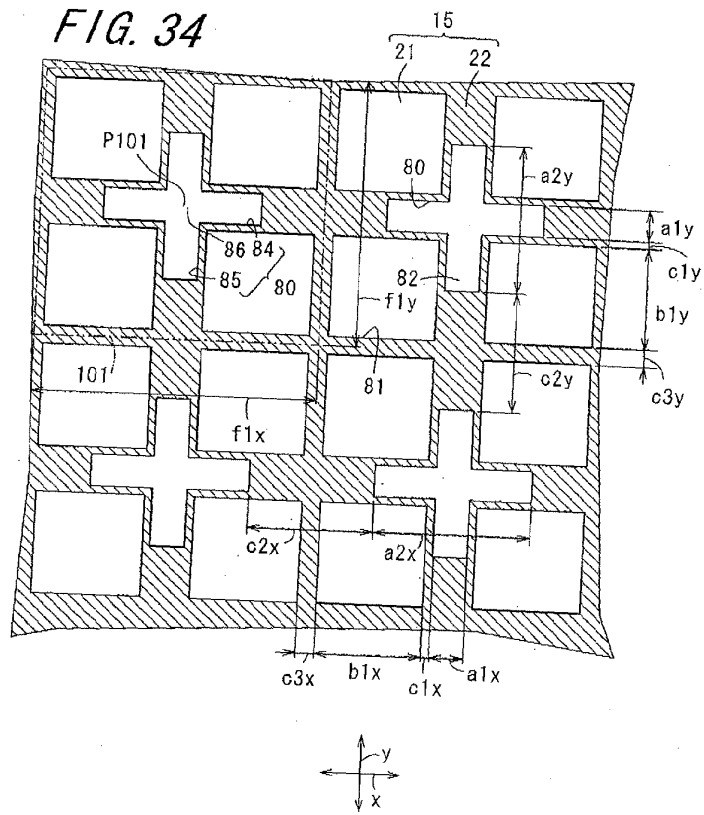












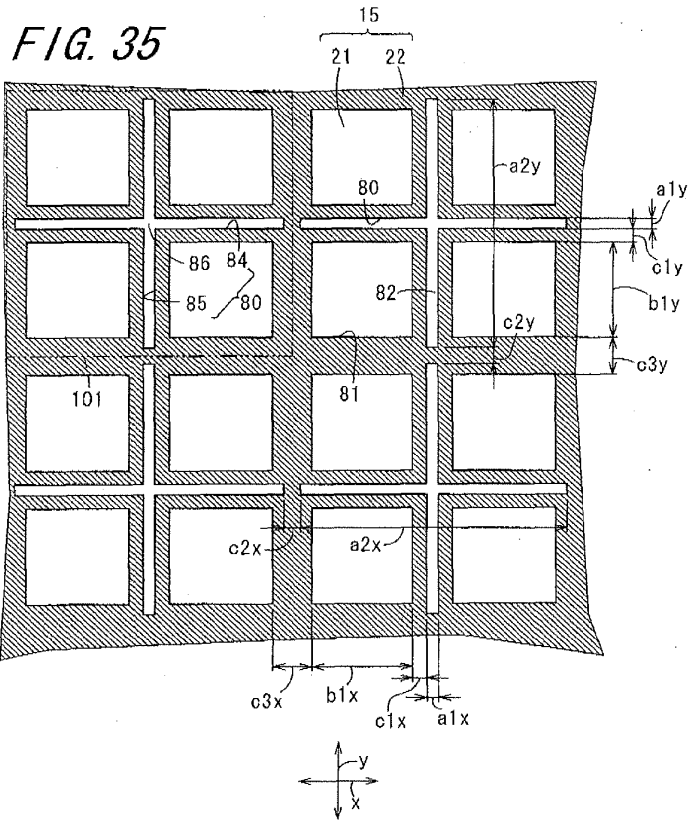
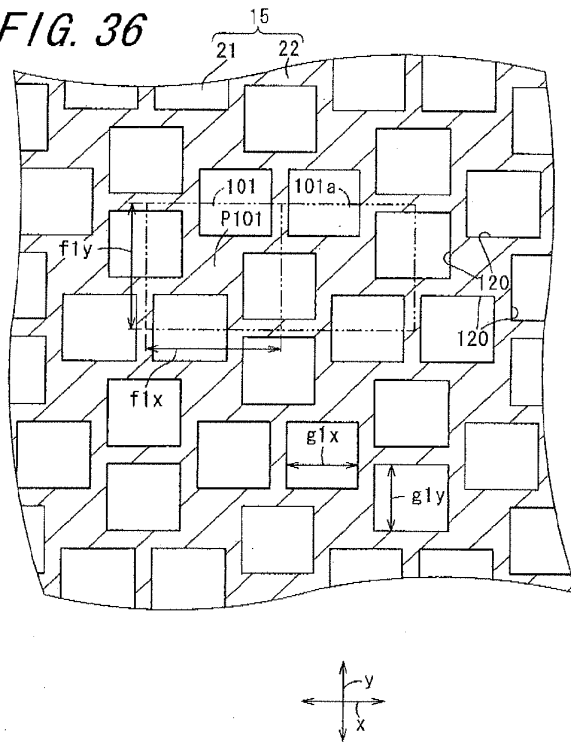
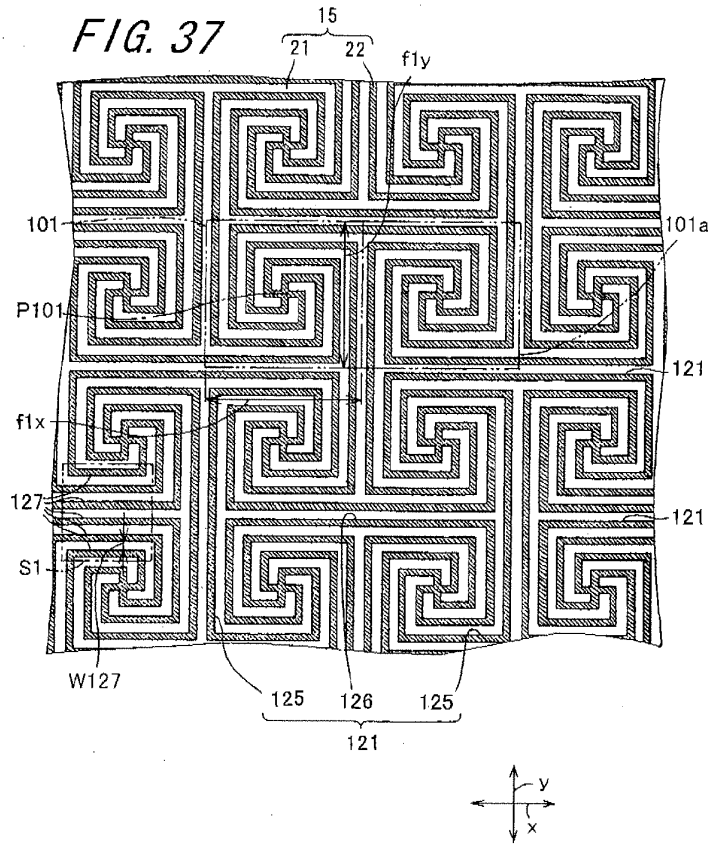


FIG. 36





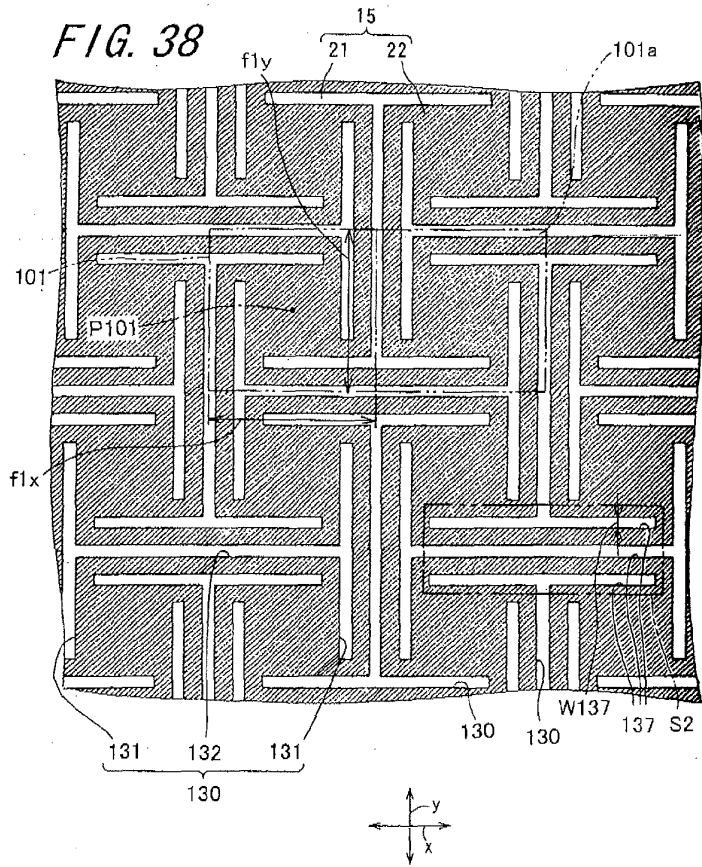
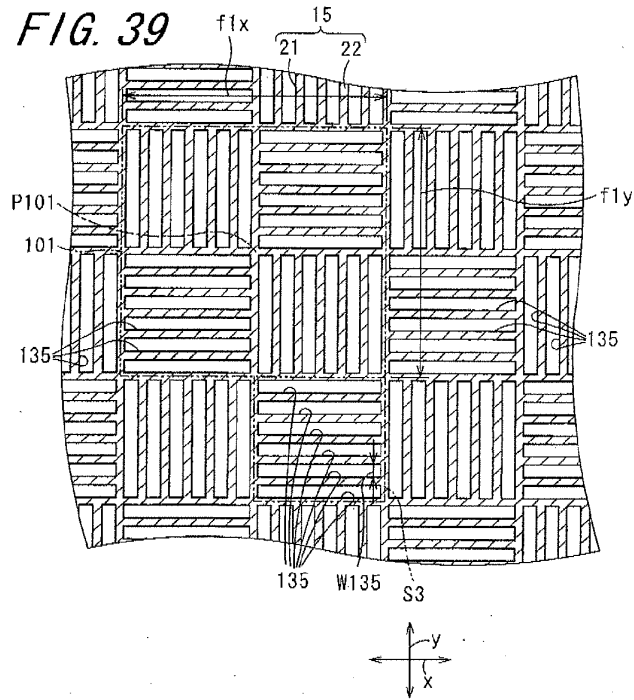
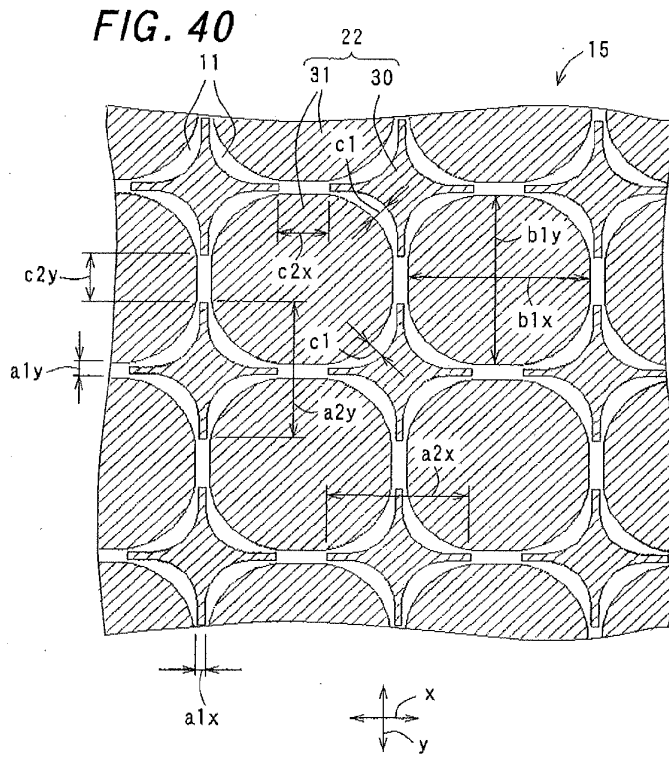


FIG. 39





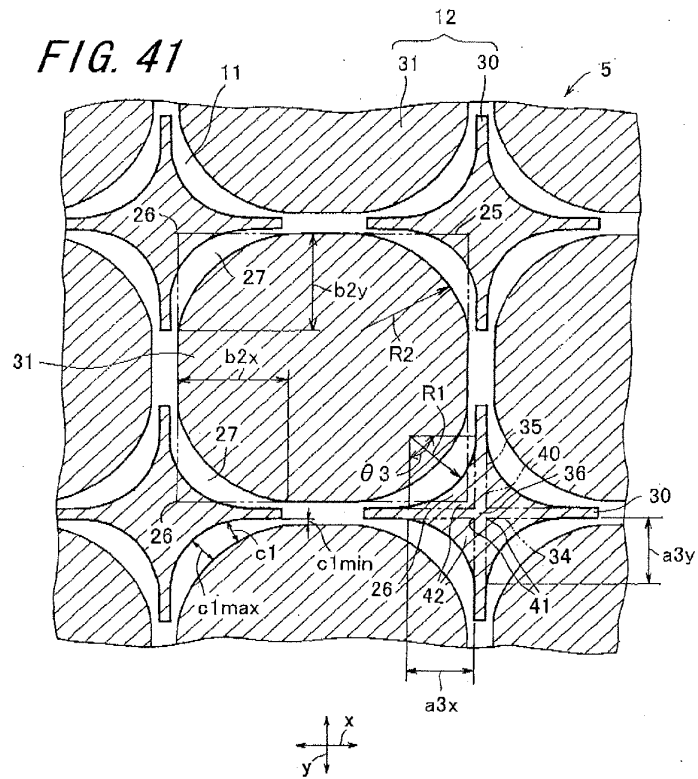


FIG. 42

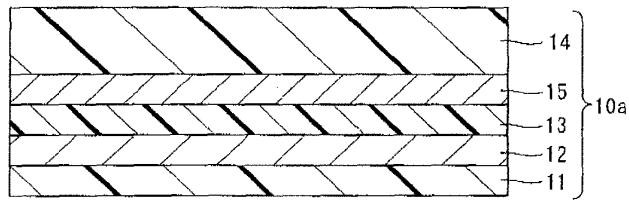


FIG. 43

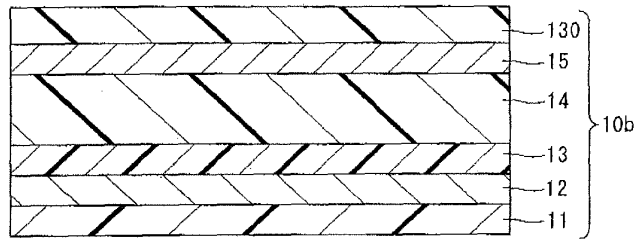


FIG. 44

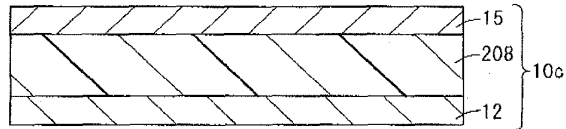


FIG. 45

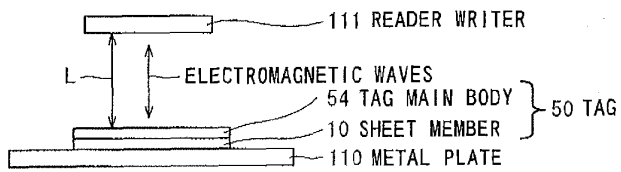


FIG. 46

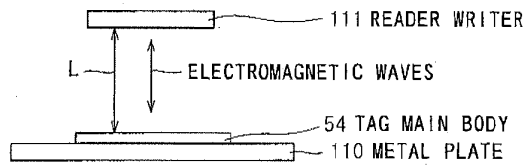


FIG. 47

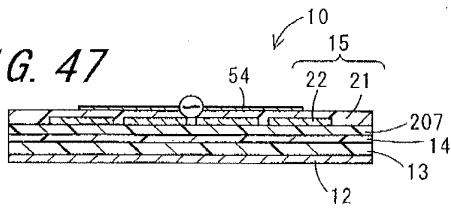


FIG. 48

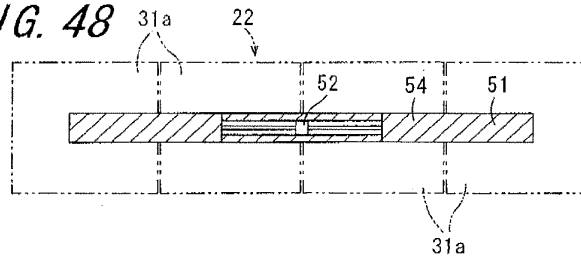
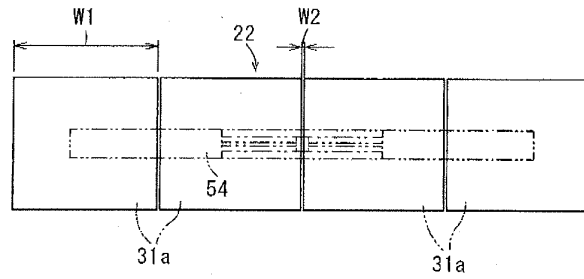


FIG. 49



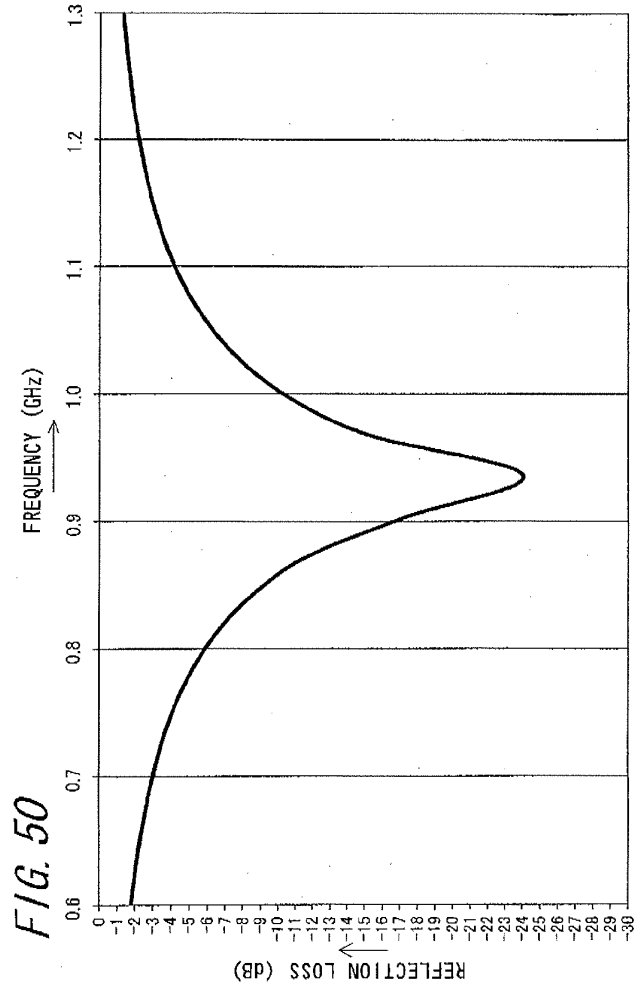


FIG. 51

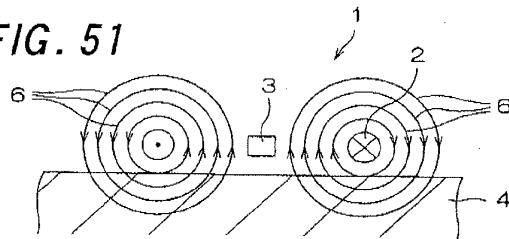
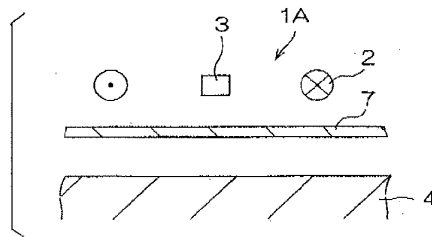


FIG. 52



INTERNATIONAL SEARCH REPORT

International application No.

PCT/JP2006/321087

A. CLASSIFICATION OF SUBJECT MATTER <i>H01Q15/14</i> (2006.01)i, <i>H01Q1/38</i> (2006.01)i, <i>H01Q9/16</i> (2006.01)i, <i>H01Q17/00</i> (2006.01)i, <i>H01Q19/10</i> (2006.01)i, <i>H05K9/00</i> (2006.01)i		
According to International Patent Classification (IPC) or to both national classification and IPC		
B. FIELDS SEARCHED		
Minimum documentation searched (classification system followed by classification symbols) <i>H01Q15/14</i> , <i>H01Q1/38</i> , <i>H01Q9/16</i> , <i>H01Q17/00</i> , <i>H01Q19/10</i> , <i>H05K9/00</i>		
Documentation searched other than minimum documentation to the extent that such documents are included in the fields searched Jitsuyo Shinan Koho 1922-1996 Jitsuyo Shinan Toroku Koho 1996-2007 Kokai Jitsuyo Shinan Koho 1971-2007 Toroku Jitsuyo Shinan Koho 1994-2007		
Electronic data base consulted during the international search (name of data base and, where practicable, search terms used)		
C. DOCUMENTS CONSIDERED TO BE RELEVANT		
Category*	Citation of document, with indication, where appropriate, of the relevant passages	Relevant to claim No.
Y	JP 3647446 B2 (Nitta Corp.), 11 May, 2005 (11.05.05), Full text; all drawings (Family: none)	1, 2, 4-18
Y	JP 2005-159337 A (Nitta Corp.), 16 June, 2005 (16.06.05), Full text; all drawings (Family: none)	1, 2, 4-18
Y	JP 2000-68676 A (Toso Co., Ltd.), 03 March, 2000 (03.03.00), Full text; all drawings (Family: none)	1, 2, 4-18
<input checked="" type="checkbox"/> Further documents are listed in the continuation of Box C.		<input type="checkbox"/> See patent family annex.
* Special categories of cited documents:	"T" later document published after the international filing date or priority date and not in conflict with the application but cited to understand the principle or theory underlying the invention	
"A" document defining the general state of the art which is not considered to be of particular relevance	"X" document of particular relevance; the claimed invention cannot be considered novel or cannot be considered to involve an inventive step when the document is taken alone	
"E" earlier application or patent but published on or after the international filing date	"Y" document of particular relevance; the claimed invention cannot be considered to involve an inventive step when the document is combined with one or more other such documents, such combination being obvious to a person skilled in the art	
"L" document which may throw doubts on priority claim(s) or which is cited to establish the publication date of another citation or other special reason (as specified)	"&" document member of the same patent family	
"O" document referring to an oral disclosure, use, exhibition or other means		
"P" document published prior to the international filing date but later than the priority date claimed		
Date of the actual completion of the international search 05 January, 2007 (05.01.07)	Date of mailing of the international search report 16 January, 2007 (16.01.07)	
Name and mailing address of the ISA/ Japanese Patent Office	Authorized officer	
Facsimile No.	Telephone No.	

Form PCT/ISA/210 (second sheet) (April 2005)

INTERNATIONAL SEARCH REPORT

International application No.

PCT/JP2006/321087

C (Continuation). DOCUMENTS CONSIDERED TO BE RELEVANT		
Category*	Citation of document, with indication, where appropriate, of the relevant passages	Relevant to claim No.
Y	JP 1-149503 A (Nippon Telegraph And Telephone Corp.), 12 June, 1989 (12.06.89), Full text; all drawings (Family: none)	1, 2, 4-18
Y A	JP 2002-314284 A (The Yokohama Rubber Co., Ltd.), 25 October, 2002 (25.10.02), Full text; all drawings (Family: none)	1, 2, 4-18 3
Y A	JP 2005-184012 A (Nitta Corp.), 07 July, 2005 (07.07.05), Full text; all drawings & JP 2005-12204 A	1, 2, 4-18 3
Y A	JP 2005-109638 A (The Yokohama Rubber Co., Ltd.), 21 April, 2005 (21.04.05), Par. Nos. [0003] to [0005] (Family: none)	1, 2, 4-18 3
A	WO 2004/93497 A1 (PPG INDUSTRIES OHIO, INC.), 28 October, 2004 (28.10.04), Full text; all drawings & US 2004/200821 A1 & EP 1614325 A1 & JP 2006-526944 A	4-9
A	JP 2003-60430 A (Mitsubishi Heavy Industries, Ltd.), 28 February, 2003 (28.02.03), Full text; all drawings (Family: none)	4-9
A	JP 2000-236214 A (Mitsubishi Electric Corp.), 29 August, 2000 (29.08.00), Full text; all drawings (Family: none)	4-9

Form PCT/ISA/210 (continuation of second sheet) (April 2005)

EP 2 096 711 A1

REFERENCES CITED IN THE DESCRIPTION

This list of references cited by the applicant is for the reader's convenience only. It does not form part of the European patent document. Even though great care has been taken in compiling the references, errors or omissions cannot be excluded and the EPO disclaims all liability in this regard.

Patent documents cited in the description

- JP 2000114132 A [0005]
- JP 2002230507 A [0006] [0009] [0009]



Espacenet

Bibliographic data: CN103094992 (A) — 2013-05-08

Wireless power receiver and control method thereof
Inventor(s): LEE KI MIN; LEE JUNG OH ± (LEE KI MIN, ; LEE JUNG OH)

Applicant(s): LG INNOTEK CO LTD ± (LG INNOTEK CO., LTD)

Classification: - international: H02J17/00
 - cooperative: G06K19/0708; G06K19/0715; G06K19/07783;
H01Q1/2225; H01Q1/526; H01Q7/00; H02J50/12;
H02J50/80; H02J7/025; H02J7/045; H04B5/0031;
H04B5/0037; H04B5/0087; H02J50/10
Application number: CN20121432152 20121102 Global Dossier
Priority number (s): KR20110114721 20111104
Also published as: CN103094992 (B) CN106026411 (A) EP2590257 (A2)
EP2590257 (A3) EP2765647 (A2) more
Abstract of CN103094992 (A)

A wireless power receiver according to an embodiment wirelessly receives power from a wireless power transmitter. The wireless power receiver includes a printed circuit board having a reception space in a predetermined area, a receiving coil disposed in the reception space of the printed circuit board for receiving power from the wireless power transmitter, and a short-range communication antenna disposed on the printed circuit board while surrounding the receiving coil.



(12) 发明专利申请

(10) 申请公布号 CN 103094992 A

(43) 申请公布日 2013.05.08

(21) 申请号 201210432152.X

(22) 申请日 2012.11.02

(30) 优先权数据

10-2011-0114721 2011.11.04 KR

(71) 申请人 LG 伊诺特有限公司

地址 韩国首尔

(72) 发明人 李奇珉 李钰五

(74) 专利代理机构 中原信达知识产权代理有限
责任公司 11219

代理人 夏凯 谢丽娜

(51) Int. Cl.

H02J 17/00(2006.01)

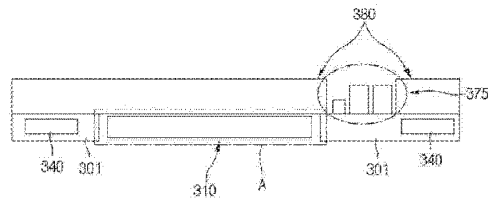
权利要求书2页 说明书7页 附图6页

(54) 发明名称

无线电力接收器及其控制方法

(57) 摘要

本发明提供一种无线电力接收器及其控制方法。根据实施例的无线电力接收器从无线电力发射器无线地接收电力。无线电力接收器包括：印制电路板，该印制电路板在预定区域中具有接收空间；接收线圈，该接收线圈被布置在印制电路板的接收空间中，用于从无线电力发射器接收电力；以及短程通信天线，该短程通信天线围绕接收线圈被布置在印制电路板上。



CN 103094992 A

1. 一种无线电力接收器,所述无线电力接收器从无线电力发射器无线地接收电力,所述无线电力接收器包括:
 - 印制电路板,所述印制电路板在预定区域中具有接收空间;
 - 接收线圈,所述接收线圈被布置在所述印制电路板的接收空间中,用于从所述无线电力发射器接收电力;以及
 - 短程通信天线,所述短程通信天线被布置在所述印制电路板上同时围绕所述接收线圈。
2. 根据权利要求1所述的无线电力接收器,进一步包括屏蔽单元,所述屏蔽单元用于屏蔽从所述接收线圈产生的磁场。
3. 根据权利要求2所述的无线电力接收器,其中所述屏蔽单元被布置成包括由所述接收线圈占据的区域。
4. 根据权利要求2所述的无线电力接收器,其中所述屏蔽单元在其预定的区域中具有接收空间,以及
 - 所述无线电力接收器进一步包括无线充电电路,所述无线充电电路被布置在所述屏蔽单元的接收空间中以通过整流从所述接收线圈接收到的电力将被整流的电力转移到负载。
5. 根据权利要求4所述的无线电力接收器,其中所述无线充电电路具有等于或者小于所述屏蔽单元的厚度的厚度。
6. 根据权利要求1所述的无线电力接收器,其中所述接收线圈具有等于或者小于所述印制电路板的厚度的厚度。
7. 根据权利要求1所述的无线电力接收器,其中所述短程通信天线被布置在所述印制电路板中,
 - 其中所述短程通信天线包括 NFC (近场通信) 天线。
8. 一种无线电力接收器,所述无线电力接收器从无线电力发射器无线地接收电力,所述无线电力接收器包括:
 - 短程通信天线,所述短程通信天线用于执行短程通信;
 - 接收线圈,所述接收线圈用于从所述无线电力发射器无线地接收电力;以及
 - 开关,所述开关用于根据所述电力的接收更改所述短程通信天线的传导状态,其中所述无线电力接收器根据所述电力的接收断开或者闭合所述开关。
9. 根据权利要求8所述的无线电力接收器,其中所述短程通信天线围绕所述接收线圈。
10. 根据权利要求8所述的无线电力接收器,其中所述无线电力接收器当接收到所述电力时断开所述开关,并且当没有接收到所述电力时闭合所述开关。
11. 根据权利要求8所述的无线电力接收器,进一步包括短程通信模块,所述短程通信模块从所述短程通信天线接收电流。
12. 根据权利要求8所述的无线电力接收器,进一步包括保护单元,所述保护单元用于当流过所述短程通信天线的电流等于或者大于阈值电流值时更改电流流动方向,
 - 其中所述保护单元包括至少一个齐纳二极管。
13. 一种控制无线电力接收器的方法,所述无线电力接收器包括用于与外部通信的短程通信天线,所述方法包括:

确定是否通过电磁感应从传输线圈接收到电力；
当接收到所述电力时，断开开关，这更改了所述短程通信天线的传导状态；
识别接收到的电力的量是否等于或者大于阈值；以及
当所述接收到的电力的量等于或者大于所述阈值时，闭合所述开关。

14. 根据权利要求 13 所述的方法，进一步包括：

当所述接收到的电力的量小于所述阈值时，断开所述开关。

15. 根据权利要求 13 所述的方法，进一步包括：

当流过所述短程通信天线的电流等于或者大于所述阈值电流值时，更改电流的流动方向，以及

其中所述电流流动方向的更改包括通过使用齐纳二极管更改所述电流流动方向。

无线电力接收器及其控制方法

技术领域

[0001] 本发明涉及一种无线电力接收器及其控制方法。

背景技术

[0002] 无线电力传输或者无线能量转移指的是向所期望的设备无线地转移电能的技术。在 19 世纪,已经广泛地使用了采用电磁感应原理的电动机或者变压器,并且然后已经提出了用于通过辐照诸如无线电波或者激光的电磁波而传输电能的方法。实际上,在日常生活中频繁地使用的电动牙刷或者电动剃刀是基于电磁感应原理而被充电的。直至现在,使用磁感应、共振和短波长射频的长距离传输已经被用作无线能量转移方案。

[0003] 近来,在无线电力传输技术中,已经广泛地使用了采用谐振的能量传输方案。

[0004] 因为在使用电磁感应的无线电力传输系统中,通过线圈无线地转移在无线电力传输器和无线电力接收器之间产生的电信号,所以使用者可以容易地对诸如便携式设备的电器充电。

[0005] 然而,由于组成接收侧的接收线圈、短程通信天线以及印制电路板中的每一个的厚度,电器的尺寸变得较大并且不容易将它们嵌入在电器中。具体地,增加与接收线圈、短程通信天线以及印制电路板的厚度相对应的电器的尺寸。

[0006] 此外,当过电流流过短程通信模块时,难以有效地处理过电流。

[0007] 此外,从接收线圈产生的磁场对电器的内部产生影响,使得电器发生故障。

发明内容

[0008] 实施例通过适当地布置接收线圈、短程通信天线以及印制电路板来提供具有最小化的厚度的无线电力接收器。

[0009] 实施例通过允许短程通信天线被包括在印制电路板中来提供具有被减少厚度的无线电力接收器。

[0010] 实施例提供一种无线电力接收器,该无线电力接收器使用屏蔽单元来防止电器发生故障。

[0011] 实施例提供一种无线电力接收器,该无线电力接收器通过使用保护单元保护短程通信模块来阻止过电流。

[0012] 根据实施例的无线电力接收器从无线电力发射器无线地接收电力。该无线电力接收器包括:印制电路板,该印制电路板在预定区域中具有接收空间;接收线圈,该接收线圈被布置在印制电路板的接收空间中,用于从无线电力发射器接收电力;以及短程通信天线,该短程通信天线被布置在印制电路板上同时围绕接收线圈。

[0013] 根据实施例的无线电力接收器从无线电力发射器无线地接收电力。无线电力接收器包括:短程通信天线,该短程通信天线用于执行短程通信;接收线圈,该接收线圈用于从无线电力发射器无线地接收电力;以及开关,该开关用于根据电力的接收来更改短程通信天线的传导状态,其中无线电力接收器根据电力的接收来断开或者闭合(short)开关。

[0014] 一种根据实施例的控制无线电力接收器的方法,该无线电力接收器包括短程通信天线,该短程通信天线用于与外部通信,该方法包括:确定是否通过电磁感应从传输线圈接收到电力;当接收到电力时,断开更改短程通信天线的传导状态的开关;识别接收到的电力的量是否等于或者大于阈值;以及当接收到的电力的量等于或者大于阈值时,闭合开关。

[0015] 根据实施例,通过适当地布置接收线圈、短程通信天线以及印制电路板能够最小化无线电力接收器的厚度。

[0016] 根据实施例,能够通过防止过电流流入无线电力接收器来防止无线电力接收器被破坏,并且能够通过屏蔽磁场来防止无线电力接收器的故障。

附图说明

[0017] 图 1 是示出根据实施例的无线电力传输系统的视图;

[0018] 图 2 是根据实施例的传输线圈的等效电路图;

[0019] 图 3 是根据实施例的无线电力传输系统的等效电路图;

[0020] 图 4 是根据实施例的无线电力接收器的框图;

[0021] 图 5 是示出根据实施例的无线电力接收器的配置的示例的视图;

[0022] 图 6 是图示根据实施例的无线电力接收器的分解立体和截面图。

[0023] 图 7 示出根据实施例的无线电力接收器的元件的布置的截面图;

[0024] 图 8 是图示根据实施例的无线电力接收器的顶表面和底表面的视图;

[0025] 图 9 是图示根据实施例的将屏蔽单元附接到无线电力接收器上的一个示例的视图;

[0026] 图 10 是图示根据实施例的将屏蔽单元插入到无线电力接收器中的一个示例的视图;以及

[0027] 图 11 是图示根据实施例的无线电力接收器的控制方法的流程图。

具体实施方式

[0028] 在下文中,将详细地描述本公开的示例性实施例,使得本领域的技术人员能够容易地理解本公开。

[0029] 图 1 图示根据实施例的无线电力传输系统。

[0030] 从电源 100 产生的电力被提供给无线电力发射器 200,使得通过电磁感应将电力转移到无线电力接收器 300。

[0031] 详细地,电源 100 是用于供应预定频率的 AC 电力的 AC 电源。

[0032] 无线电力发射器 200 包括传输线圈 210。传输线圈 200 被连接到电源 100,使得 AC 电流流过传输线圈 210。当 AC 电流流过传输感应线圈 210 时,由于电磁感应 AC 电流被感应到与传输线圈 210 物理上隔开的接收线圈 310,使得 AC 电力被转移到无线电力接收器 300。

[0033] 在彼此阻抗匹配的两个 LC 电路之间可以通过电磁感应转移电力。通过电磁感应的电力传输可使得能够进行高效的电力传输。

[0034] 无线电力接收器 300 可以包括接收线圈 310、整流器电路 320 以及负载 330。在实施例中,负载 330 可以不包括在无线电力接收器 300 中,而是可以单独地提供。通过电磁感应在接收线圈 310 处接收到通过传输线圈 210 传输的电力。通过整流器电路 320 将转移到

接收线圈 310 的电力转移到负载 330。

[0035] 图 2 是根据实施例的传输线圈 210 的等效电路图。

[0036] 如在图 2 中所示,传输线圈 210 可以包括电感器 L1 和电容器 C1,并且形成具有适当的电感值和适当的电容值的电路。电容器 C1 可以是可变电容器。通过控制可变电容器,可以执行阻抗匹配。同时,接收线圈 320 的等效电路可以等同于在图 2 中描述的电路。

[0037] 图 3 是根据实施例的无线电力传输系统的等效电路图。

[0038] 如在图 3 中所示,传输线圈 210 可以包括具有预定电感值的电感器 L1 和具有预定电容值的电容器 C1。

[0039] 此外,如在图 3 中所示,接收线圈 310 可以包括具有预定电感值的电感器 L2 和具有预定的电容值的电容器 C2。整流器电路 320 可以包括二极管 D1 和整流电容器 C3,使得整流器电路 320 将 AC 电力转换成 DC 电力并且输出该 DC 电力。

[0040] 虽然负载 330 被表示为 DC 电源,但是负载 330 可以是要求 DC 电力的电池或者其它设备。

[0041] 接下来,将参考图 4 至图 10 描述根据实施例的无线电力接收器。

[0042] 图 4 是根据实施例的无线电力接收器的框图。图 5 是示出根据实施例的无线电力接收器的配置的示例的视图,图 6 是图示根据实施例的无线电力接收器的分解立体图和截面图,图 7 是示出根据实施例的无线电力接收器的元件的布置的截面图,图 8 是图示根据实施例的无线电力接收器的顶表面和底表面的视图,图 9 是图示根据实施例的将屏蔽单元附接到无线电力接收器上的一个示例的视图,并且图 10 是图示根据实施例的将屏蔽单元插入到无线电力接收器中的一个示例的视图。

[0043] 首先,参考图 4,无线电力接收器 300 可以包括接收线圈 310、短程通信天线 340、开关 350、保护单元 360、短程通信模块 370、屏蔽单元 380、以及控制器 390。

[0044] 根据实施例的无线电力接收器 300 可以被安装在要求电力的终端或者电器中,诸如便携式终端、膝上型计算机、以及鼠标。

[0045] 接收线圈 310 通过电磁感应从无线电力发射器 200 的传输线圈 210 接收电力。即,如果当 AC 电流流过传输线圈 210 时产生磁场,则通过所产生的磁场将电流感应到接收线圈 310,使得 AC 电流从中流过。

[0046] 在实施例中,接收线圈 310 可以被布置在印制电路板 301 的接收空间中。

[0047] 通过缠绕导线数次可以提供接收线圈 310。在实施例中,接收线圈 310 可以具有螺旋状,但是实施例不限于此。

[0048] 短程通信天线 340 可以与能够执行短程通信的读取器通信。短程通信天线 340 可以执行向读取器传输信息和从其接收信息的天线的功能。在实施例中,短程通信天线 340 可以被布置在接收线圈 310 的外部。在实施例中,接收线圈 310 可以被布置在印制电路板 301 内部的接收空间中,并且短程通信天线 340 可以被布置为围绕印制电路板 301 上的接收线圈 310。

[0049] 将参考图 6 更加详细地描述以上配置。

[0050] 参考在图 6 (a)中示出的无线电力接收器 300 的分解立体图,无线电力接收器 300 可以包括外壳 302、印制电路板 301、接收线圈 301、短程通信天线 340 以及屏蔽单元 380。在此,外壳 302 指的是便携式终端的外壳,但是实施例不限于此。稍后将描述屏蔽单元 380。

[0051] 参考图 6 (a), 可以识别到, 接收线圈 310 被布置在印制电路板 301 的接收空间 A 中并且短程通信天线 340 被布置在印制电路板 301 上。即, 接收线圈 301 可以被布置在设置在印制电路板 301 内部的接收空间 A 中, 并且短程通信天线 340 可以围绕接收空间 A 被布置在印制电路板 301 的上侧处。

[0052] 图 6 (b) 是示出在图 6 (a) 中图示的无线电力接收器 300 的元件的布置的截面图。

[0053] 在实施例中, 可以通过注塑成型将印制电路板 301、接收线圈 310 以及短程通信天线 340 插入外壳 302 中。此外, 如上所述, 短程通信天线 340 可以围绕被安置在接收空间 A 中的接收线圈 310 被布置在印制电路板 301 上的外围处。

[0054] 在下文中, 将参考图 7 和图 8 更加详细地描述在接收线圈 310、短程通信天线 340 以及印制电路板 301 当中的布置。

[0055] 首先, 参考图 7, 印制电路板 301 在其预定的区域中具有接收空间 A。在实施例中, 预定的区域可以包括印制电路板 301 的中心部分。在实施例中, 印制电路板 301 的中心部分可以具有诸如矩形和圆形的多边形的接收空间。

[0056] 接收线圈 310 被布置在印制电路板 301 的接收空间 A 中, 并且通过电磁感应从传输感应线圈 310 接收电力。在实施例中, 接收线圈 310 和印制电路板 301 可以被制造成使得接收线圈 310 的厚度可以等于印制电路板 301 的厚度或者接收线圈 310 的厚度可以小于印制电路板 301 的厚度。在这样的情况下, 防止由于接收线圈 310 和短程通信天线 340 的厚度而使无线电力接收器 300 的厚度增加, 使得能够容易地将无线电力接收器 310 嵌入便携式终端的外壳中。

[0057] 在实施例中, 接收线圈 310 可以被制造成具有与印制电路板 310 的接收空间 A 的形状相匹配的形状。例如, 当印制电路板 310 的接收空间 A 的形状是矩形时, 接收线圈 310 或者导线可以被缠绕成矩形。当印制电路板 310 的接收空间 A 的形状是圆形时, 接收线圈 310 或者导线可以被缠绕成圆形。因此, 接收线圈 310 或者导线可以具有各种形状。

[0058] 短程通信天线 340 可以被包括在印制电路板 301 中并且可以被配置成围绕接收线圈 310。在实施例中, 短程通信天线 340 可以被制造成使得短程通信天线 340 可以被嵌入印制电路板 301 中, 并且可以被配置成围绕具有诸如矩形或者圆形的各种形状的接收线圈 310 的外围。在这样的情况下, 能够防止由于印制电路板 301 和短程通信天线 340 的厚度而使无线电力接收器 300 的厚度增加, 使得可以容易地将无线电力接收器 300 安装在便携式终端的外壳中。

[0059] 无线电力接收器 300 可以进一步包括屏蔽单元 380, 该屏蔽单元 380 用于屏蔽通过接收线圈 310 产生的磁场。在实施例中, 屏蔽单元 380 可以被布置成覆盖接收线圈 310 所占据的区域。在实施例中, 屏蔽单元 380 可以被布置在接收线圈 310 和短程通信天线 340 上, 使得屏蔽单元 380 可以包括接收线圈 310 和短程通信天线 340 所占据的区域。

[0060] 在实施例中, 屏蔽单元 380 可以在其预定的区域中具有接收空间。放置在印制电路板 301 的顶表面上的无线充电电路 375 可以被布置在屏蔽单元 380 的接收空间中。无线充电电路 375 可以包括整流器电路, 该整流器电路用于将 AC 电力转换成 DC 电力; 电容器, 该电容器用于消除噪声信号; 以及主 IC 芯片, 该主 IC 芯片用于执行用于无线电力接收的操作。

[0061] 在实施例中, 屏蔽单元 380 和无线充电电路 375 可以被制造成使得屏蔽单元 380

的厚度可以等于无线充电电路 375 的厚度或者屏蔽单元 380 的厚度可以小于无线充电电路 375 的厚度。在这样的情况下,能够防止由于屏蔽单元 380 和无线充电电路 375 的厚度而使无线电力接收器 300 的厚度增加,使得能够容易地将无线电力接收器 300 安装在便携式终端的外壳中。

[0062] 图 8 (a)是示出根据实施例的无线电力接收器的底表面的视图并且图 8 (b)是示出根据实施例的无线电力接收器的顶表面的视图。

[0063] 图 8 (a)图示根据实施例的印制电路板 301、接收线圈 310 以及短程通信天线 340 的布置。印制电路板 301 在中心区域中具有接收空间 A,并且具有矩形的接收线圈 310 被布置在接收空间 A 中。短程通信天线 340 被嵌入在印制电路板 301 中。在这样的情况下,能够防止由于印制电路板 301 和短程通信天线 340 的厚度而使无线电力接收器 300 的厚度增加,使得能够容易地将无线电力接收器安装在便携式终端的外壳中。

[0064] 此外,接收线圈 310 和印制电路板 301 可以被制造成使得接收线圈 310 的厚度可以等于印制电路板 301 的厚度或者接收线圈 310 的厚度可以小于印制电路板 301 的厚度。在这样的情况下,能够防止由于接收线圈 310 和印制电路板 301 的厚度而使无线电力接收器 300 的厚度增加,使得能够容易地将无线电力接收器 300 安装在便携式终端的外壳中。

[0065] 图 8 (b)图示根据实施例的无线充电电路 375 和屏蔽单元 380 的布置。屏蔽单元 380 可以在其预定的区域中具有接收空间,并且无线充电电路 375 可以被布置在屏蔽单元 380 的接收空间中。

[0066] 在实施例中,屏蔽单元 380 和无线充电电路 375 可以被制造成使得无线充电电路 375 的厚度可以等于无线充电电路 375 的厚度或者屏蔽单元 380 的厚度可以小于无线充电电路 375 的厚度。在这样的情况下,能够防止由于屏蔽单元 380 和无线充电电路 375 的厚度而使无线电力接收器 300 的厚度增加,使得能够容易地将无线电力接收器 300 安装在便携式终端的外壳中。

[0067] 再次参考图 4,虽然各种技术能够被应用于在下面将描述的无线通信天线 340 和短程通信模块 370 中使用的短程通信协议,但是 NFC (近场通信)可以优选地被用于无线通信天线 340 和短程通信模块 370。NFC 是用于通过 13.56MHz 的带宽在短范围内执行无线通信的技术。

[0068] 开关 350 被连接到短程通信天线 340 并从下面要描述的控制单元 390 接收断开或者闭合信号,使得开关 350 可以改变短程通信天线的导电状态。

[0069] 如果确定从传输线圈 320 接收到电力,则开关 350 可以从控制单元 390 接收断开信号,使得开关 350 可以阻止电流流过短程通信天线 340。

[0070] 如果无线电力接收器 300 被充电有等于或者高于阈值的电力,则开关 350 可以从控制单元 390 接收闭合信号,使得开关 350 可以通过短程通信天线 340 传导电流,因此开关 350 可以允许短程通信天线 340 被操作。

[0071] 当等于或者高于阈值电流值的电流流过保护单元 360 时操作保护单元 360,使得保护单元 360 可以阻止等于或者高于阈值电流值的电流被转移到短程通信模块 370。

[0072] 在实施例中,如在图 5 中所示,保护单元 360 可以包括至少一个齐纳二极管。齐纳二极管可以仅允许具有等于或者小于阈值电流值的电流流过电路。阈值电流值可以被不同地设置并且可以是极限值,在该极限值可以正常地操作短程通信模块 370。

[0073] 当转移到短程通信模块 340 的电流具有阈值电流值或者以上时,保护单元 360 可以改变流动方向或者电流的流动以防止过电流流过短程通信模块 370。

[0074] 参考图 5,如果流过短程通信模块 340 的电流具有阈值电流值或者以上,则操作保护单元 350。参考图 5,当在 A 方向中流动的电流具有阈值电流值或者以上时,具有阈值电流值或者以上的电流流入安置在保护单元 350 的上侧处的齐纳二极管中。

[0075] 在 B 方向上流动的电流具有阈值电流值或者以上的情况下,执行相同的程序。

[0076] 具有阈值电流值或者以上的过电流流过齐纳二极管并且作为热能放电。即,保护单元 360 可以防止过电流流过短程通信模块 370,使得可以防止通信模块 370 的损坏。

[0077] 再次参考图 4,短程通信模块 370 可以通过短程通信天线 340 接收电流。虽然各种类型的通信技术能够被应用于短程通信模块 370,但是可以优选地使用 NFC (近场通信) 协议。

[0078] 屏蔽单元 380 可以改变从接收线圈 310 产生的电磁的方向。屏蔽单元 380 可以吸收从接收线圈 310 产生的磁场并且可以将吸收的磁场作为热能放电。

[0079] 即,因为屏蔽单元 380 可以改变从线圈 310 产生的磁场的方向或者吸收和放电作为热能的磁场,所以可以防止磁场对安装无线电力接收器 300 的电器内部的任何其它元件施加不好的影响。即,屏蔽单元 380 能够防止由应用到其它元件的磁场引起的故障。

[0080] 屏蔽单元 380 可以包括铁素体,但是实施例不限于此。

[0081] 屏蔽单元 380 可以被布置在无线电力接收器 300 的一侧处。

[0082] 在下文中,将参考图 9 和图 10 描述无线电力接收器 300 上的屏蔽单元 380 的布置。

[0083] 首先,参考图 9,在短程通信天线 340 已经被布置在印制电路板 301 上之后,屏蔽单元 380 可以通过粘合剂被附接到印制电路板 301 的一侧。

[0084] 参考图 10,当执行将短程通信天线 340 布置在印制电路板 301 上的程序时,可以将屏蔽单元 380 插入印制电路板 301 中。即,不同于图 9,因为屏蔽单元 380 被布置在印制电路板 301 中,所以在没有执行将屏蔽单元 380 布置在印制电路板 301 的一侧处的程序的情况下可以在布置短程通信天线 340 的程序中包括布置屏蔽单元 380 的程序。即,如上所述,根据在图 8 中示出的实施例,当屏蔽单元 380 被插入印制电路板 301 中时,可以减少与粘合剂 303 的厚度相对应的无线电力接收器 300 的整个厚度。因此,附接屏蔽单元 380 的单独的程序不是必要的,因此可以简化制造工艺。

[0085] 再次参考图 4,控制器 390 可以控制无线电力接收器 300 的整个操作。

[0086] 控制器 390 可以根据电力的接收将无线电力接收器 300 的操作模式更改为充电模式或通信模式。在实施例中,充电模式可以是无线电力接收器 300 没有通过短程通信模块 370 与外部通信,而是从传输线圈 210 接收电力。通信模式可以是无线电力接收器 300 没有从传输线圈 210 接收电力,而是通过短程通信模块 370 与外部通信。

[0087] 控制器 390 可以通过断开或者闭合开关 350 来更改短程通信天线 340 的传导状态。如果在开关 350 被闭合的状态下将电流感应到接收线圈 310,则控制器 390 可以断开开关 350 以将无线电力接收器 300 的操作模式更改为充电模式。即,如果控制器 390 从传输线圈 210 接收电力,则控制器 390 断开开关 350 以防止电流流过短程通信天线 340。在开关 350 被断开的状态中,如果电流没有感应到接收线圈 310,则控制器 390 可以闭合开关 350 以将无线电力接收器 300 的操作模式更改为通信模式。即,如果控制器没有从传输线圈

210 接收电力,则控制器 390 可以闭合开关 350 以允许将电流感应到短程通信天线 340。

[0088] 为了更改短程通信天线 340 的传导状态,控制器 390 可以感测流过接收线圈 310 的电流。在另一实施例中,无线电力接收器 300 可以进一步包括单独的电流感测单元(未示出),其能够感测被感应到接收线圈 310 的电流以感测流过接收线圈 310 的电流。

[0089] 控制器 390 可以根据在无线电力接收器 300 处接收到的电力的量来断开或者闭合开关 350。这将参考图 11 在下面加以描述。

[0090] 图 11 图示根据实施例的无线电力接收器的控制方法的流程图。

[0091] 在下文中,将参考图 1 至图 10 描述根据实施例的无线电力接收器的控制方法。

[0092] 在步骤 S101 中,控制器 390 可以确定接收线圈 310 是否通过电磁感应从传输线圈 210 接收到电力。在实施例中,无线电力接收器 300 可以进一步包括检测单元(未示出)以确定是否接收到电力。检测线圈可以被用作检测单元。

[0093] 在步骤 S103 中,如果确定接收线圈 310 通过电磁感应从传输线圈 210 接收到电力,则可以断开开关 350,这更改了短程通信天线 340 的传导状态。即,控制器 390 可以将断开信号传输到开关 350 以防止电流流过短程通信天线 340。在实施例中,当确定接收线圈 310 通过电磁感应从传输线圈 210 接收到电力时,无线电力接收器 300 可能处于充电模式中。当无线电力接收器 300 在充电模式中操作以从传输线圈 310 接收电力时,流过短程通信天线的电流必须被切断,因为在充电模式期间产生的磁场可能干扰短程通信模块 370 和外部之间的通信。

[0094] 然后,在步骤 S105 中,控制器 390 可以确定在无线电力接收器 300 处接收到的电力的量是否大于阈值。在实施例中,虽然阈值对应于无线电力接收器 300 被充电 100% 的状态,但是阈值不限于此并且可以由用户不同地设置。

[0095] 然后,在步骤 S107 中,当电力的量具有阈值或者以上时,控制器 390 允许开关被闭合。在这样的情况下,无线电力接收器 300 终止充电模式并且在通信模式中操作。

[0096] 然后,在步骤 S109 中,控制器 390 确定流过短程通信天线 340 的电流是否等于或者大于阈值电流值。在步骤 S111 中,当流过短程通信天线 340 的电流等于或者大于阈值电流值时,可以更改电流流动方向。在实施例中,阈值电流值可以意指允许正常地操作短程通信的极限值。在实施例中,用户可以不同地设置阈值电流值。在实施例中,通过保护单元 360 可以执行电流流动方向的更改。在实施例中,保护单元 360 可以是齐纳二极管。如果具有阈值电流值或者以上的电流流动,则齐纳二极管执行作为热能使电流放电的功能。在这样的情况下,齐纳二极管可以防止过电流流过短程通信模块 370,使得可以防止短程通信模块 370 的损坏。

[0097] 虽然已经参考本公开的多个说明性实施例描述了实施例,但是应该理解,本领域技术人员能够设计将落入本公开的原理的精神和范围内的多个其它的修改和实施例。更加具体地,在本公开、附图和所附权利要求的范围内,在主题组合布置的构件和 / 或布置中,各种变化和修改都是可能的。除了构件和 / 或布置的变化和修改,对于本领域技术人员而言,可替代的使用也将是明显的。

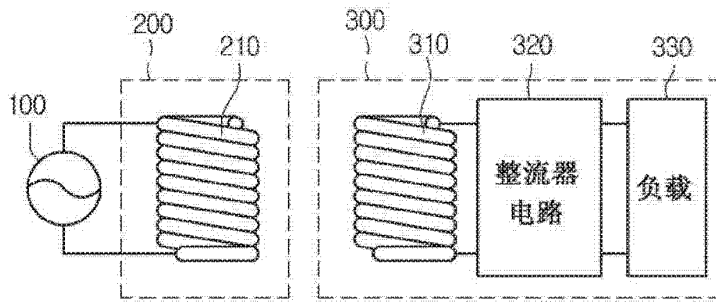


图 1

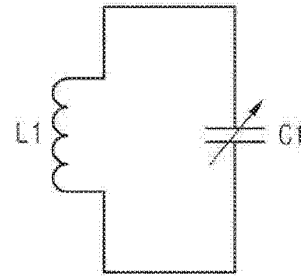


图 2

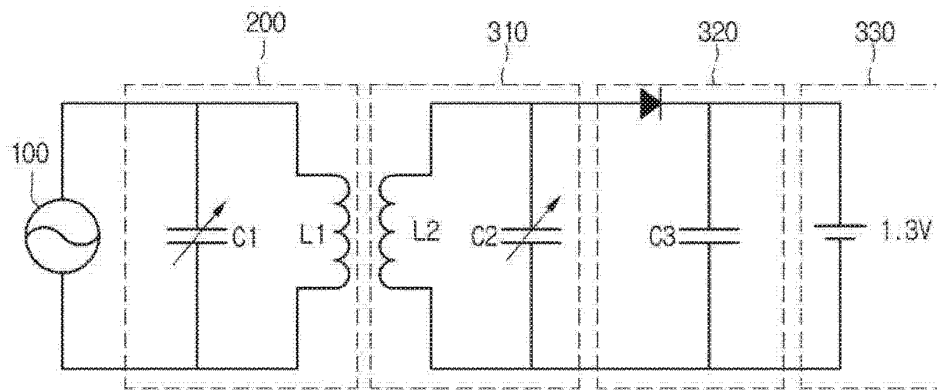


图 3

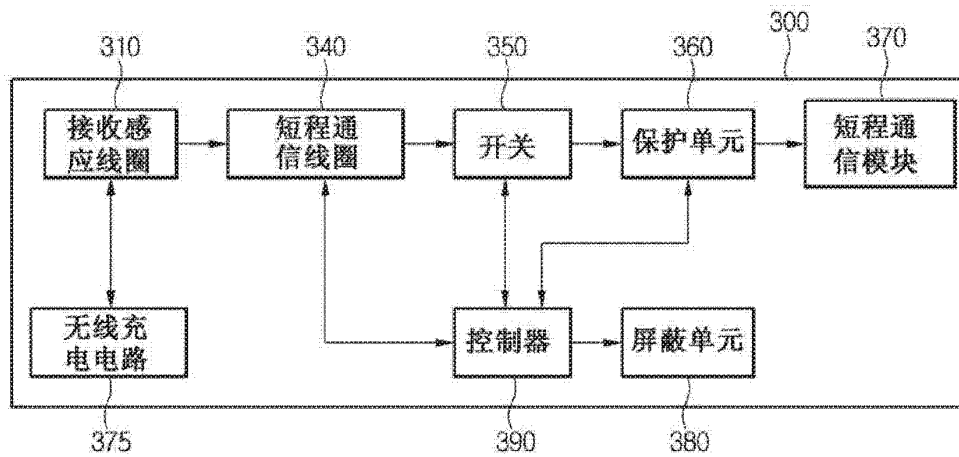


图 4

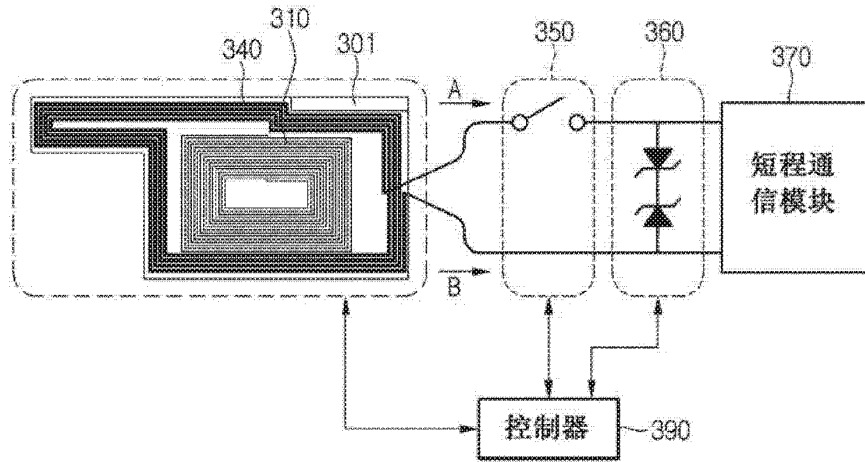


图 5

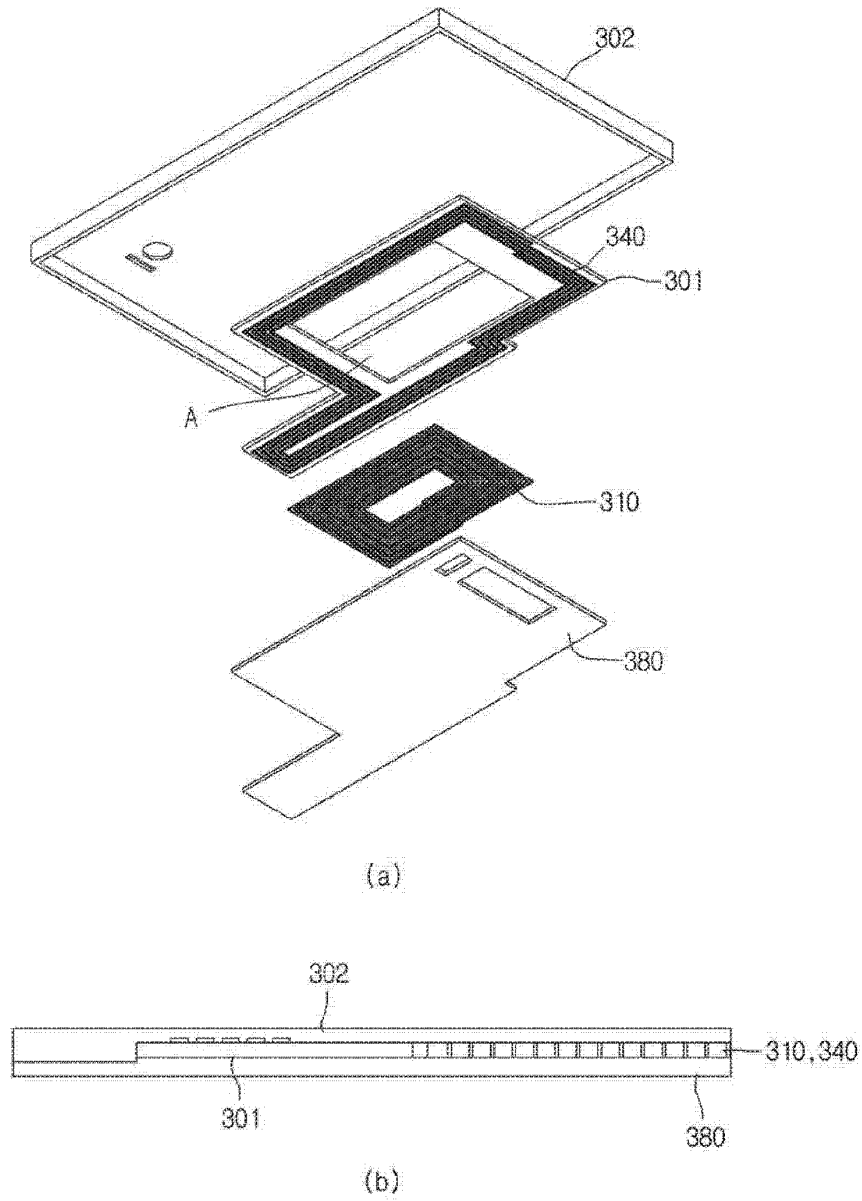


图 6

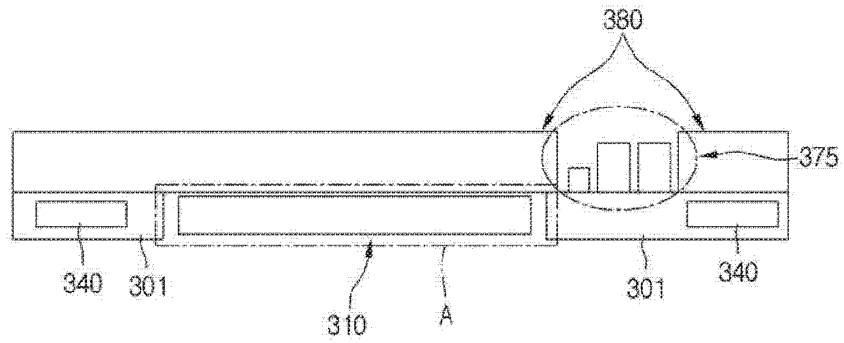


图 7

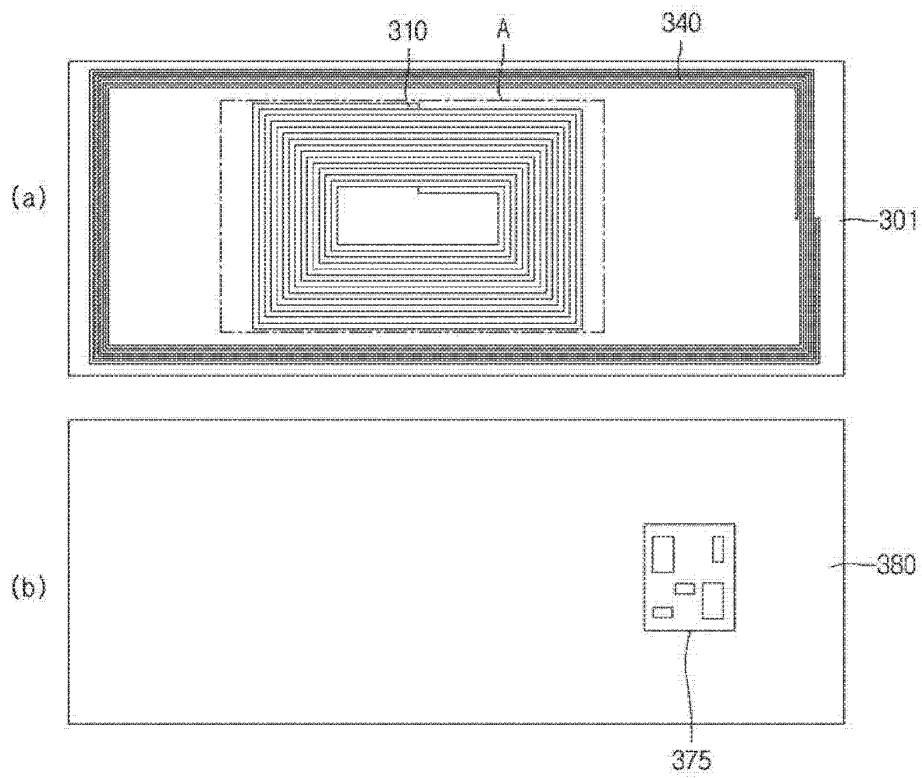


图 8

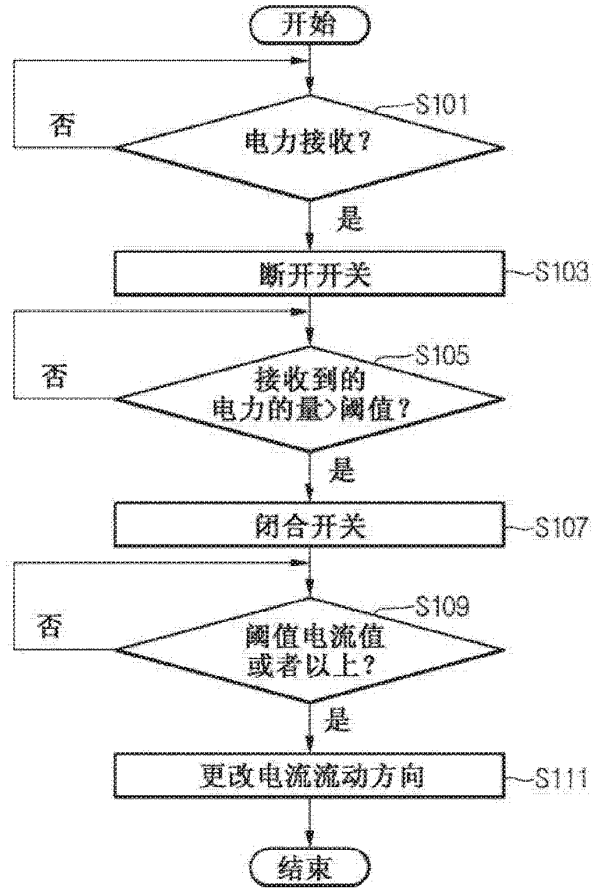


图 11



Espacenet

Bibliographic data: CN102598168 (A) — 2012-07-18**Flux concentrator and method of making a magnetic flux concentrator**

Inventor(s): BAARMAN DAVID W; SCHWANNECKE JOSHUA K; TAYLOR ROY M JR; NORCONK MATTHEW J; STONER WILLIAM T JR; TURNER KAITLYN J; BERWALD THOMAS J; MILES MICHAEL E ±
(BAARMAN DAVID W, ; SCHWANNECKE JOSHUA K, ; TAYLOR ROY M. JR, ; NORCONK MATTHEW J, ; STONER WILLIAM T. JR, ; TURNER KAITLYN J, ; BERWALD THOMAS J, ; MILES MICHAEL E)

Applicant(s): ACCESS BUSINESS GROUP INT LLC ± (ACCESS BUSINESS GROUP INT LLC)

Classification: - international: H01F27/02; H01F38/14; H01F41/14; H01F5/06
- cooperative: H01F1/26; H01F1/375; H01F27/255; H01F27/327;
H01F38/14

Application number: CN2010849434 20100825 Global Dossier

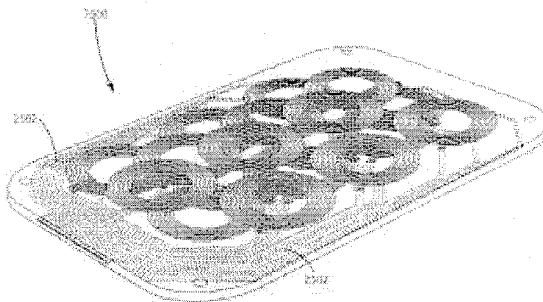
Priority number(s): WO2010US46611 20100825 ; US20090236732P 20090825 ;
US20090267187P 20091207

Also published as: CN102598168 (B) KR101671048 (B1) KR20120057636 (A)
TW201126551 (A) TWI451458 (B) US2011050382 (A1)
US8692639 (B2) WO2011031473 (A2) WO2011031473 (A3) less

Abstract of CN102598168 (A)

A flux concentrator and method for manufacturing a flux concentrator is provided. The method can include combining powdered soft magnetic material, a binder, a solvent, an internal lubricant; mixing the materials to create a mixture, evaporating the solvent from the mixture, molding the mixture to form a flux concentrator, and curing the flux

concentrator. The flux concentrator may be laminated and broken into multiple pieces, which makes the flux concentrator more flexible. Breaking the flux concentrator does not significantly affect the magnetic properties. Since the permeability of the binder is



very similar to that of air, adding tiny air gaps between the fractions is not significantly different than adding more binder.



(12) 发明专利

(10) 授权公告号 CN 102598168 B

(45) 授权公告日 2015.06.17

(21) 申请号 201080049434.0

(74) 专利代理机构 中国专利代理(香港)有限公司 72001

(22) 申请日 2010.08.25

代理人 张昱 杨楷

(30) 优先权数据

61/236732 2009.08.25 US

61/267187 2009.12.07 US

(51) Int. Cl.

H01F 38/14(2006.01)

H01F 41/14(2006.01)

H01F 27/02(2006.01)

H01F 5/06(2006.01)

(85) PCT国际申请进入国家阶段日

2012.04.25

(86) PCT国际申请的申请数据

PCT/US2010/046611 2010.08.25

审查员 黄万国

(87) PCT国际申请的公布数据

W02011/031473 EN 2011.03.17

(73) 专利权人 捷通国际有限公司

地址 美国密执安州

(72) 发明人 D·W·巴曼 J·K·施万内克

R·M·小泰勒 M·J·诺尔康克

W·T·小斯通纳 K·J·特纳

T·J·伯沃德 M·E·迈尔斯

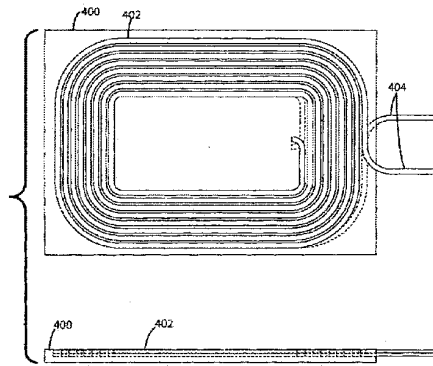
权利要求书2页 说明书12页 附图19页

(54) 发明名称

通量集中器和制作磁通量集中器的方法

(57) 摘要

本发明提供了一种通量集中器和用于制造通量集中器的方法。该方法可包括:使粉末状软磁材料、粘结剂、溶剂、内部润滑剂相结合;将这些材料混合以生成混合物,将溶剂从混合物中蒸发,将混合物模制以形成通量集中器,并且将通量集中器固化。该通量集中器可被层压并且打断成多个片块,这使得通量集中器更为柔性。将通量集中器打断不会显著地影响磁性能。由于粘结剂的渗透性与空气的渗透性非常相似,在片段之间加入极小的空气间隙与加入更多粘结剂相比不会有显著的不同。



CN 102598168 B

1. 一种层压的通量集中器组件,其包括:

通量集中器,其具有厚度、顶面和底面;以及

线圈,其被嵌入在所述通量集中器中,其中所述线圈的一个侧面与所述通量集中器的所述顶面齐平而形成了暴露的侧面,并且所述线圈的另一个侧面被嵌入在所述通量集中器的所述厚度内而形成了未暴露的侧面,其中所述线圈能够在所述暴露的侧面上感应耦合,并且不能够在所述未暴露的侧面上感应耦合;

其中所述通量集中器包括刻痕,以对所述通量集中器响应于弯曲而打断的地方产生影响;以及

层压件,其被粘合性地且紧固到所述通量集中器上,形成了在所述层压件和所述通量集中器之间的结合,其中所述层压件和所述结合将在所述刻痕的至少一部分处或附近响应于弯曲而被打断的所述通量集中器的多个片块保持在一起,其中将所述层压的通量集中器打断不会显著地影响所述层压的通量集中器的磁性能。

2. 如权利要求 1 所述的层压的通量集中器组件,其中所述线圈选自包括了初级线圈和次级线圈的组,所述初级线圈用于传输无线电能,所述次级线圈用于接收无线电能。

3. 如权利要求 1 所述的层压的通量集中器组件,其中所述通量集中器使电磁场集中以增加感应耦合。

4. 如权利要求 1 所述的层压的通量集中器组件,其中所述线圈是模压线圈和导线线圈中的至少一个。

5. 如权利要求 1 所述的层压的通量集中器组件,其还包括磁体或磁性吸引器,所述磁体或磁性吸引器能够为远程装置与无线电能传输系统的校准提供足够的磁性吸引。

6. 如权利要求 5 所述的层压的通量集中器组件,其中所述磁体或磁性吸引器被暴露于所述通量集中器表面上、或者被嵌入在所述通量集中器的所述表面的下方。

7. 如权利要求 1 所述的层压的通量集中器组件,其还包括了磁体,其中所述通量集中器组件包括在所述磁体和所述通量集中器之间的绝缘体,用以使由所述磁体引起的交流场饱和度的影响被最小化。

8. 如权利要求 1 所述的层压的通量集中器组件,其还包括被层压在所述通量集中器的所述顶面上的一层增强材料。

9. 一种柔性的通量集中器组件,其包括:

通量集中器,其具有厚度和表面;

其中所述通量集中器包括刻痕,以对所述通量集中器响应于弯曲而打断的地方产生影响;

层压件,其被粘合性地且紧固到所述通量集中器的所述表面的至少一部分上,形成了在所述层压件和所述通量集中器的所述表面的所述至少一部分之间的结合;

其中响应于将所述柔性的通量集中器折弯:1) 所述通量集中器能够被打断成其间具有空气间隙的多个片块,其中,响应于在所述刻痕的至少一部分处或附近打断所述柔性的通量集中器,所述层压件和所述结合将所述多个片块保持在一起,从而使得所述空气间隙不会显著地影响所述通量集中器的磁性能;并且,2) 所述层压件保持且粘合性地紧固到所述通量集中器的所述表面的所述至少所述部分上。

10. 如权利要求 9 所述的柔性的通量集中器组件,其中所述层压件围绕所述通量集中

器。

11. 如权利要求 9 所述的柔性的通量集中器组件,其包含:

线圈,其被嵌入在所述通量集中器中,其中所述线圈的一个侧面与所述通量集中器的所述表面齐平而形成了暴露的侧面,并且所述线圈的另一个侧面被嵌入在所述通量集中器的所述厚度内而形成了未暴露的侧面,其中所述线圈能够在所述暴露的侧面上感应耦合,并且不能够在所述未暴露的侧面上感应耦合。

12. 如权利要求 9 所述的柔性的通量集中器组件,其还包括磁体或磁性吸引器,所述磁体或磁性吸引器能够为远程装置与无线电能传输系统的校准提供足够的磁性吸引。

13. 如权利要求 9 所述的柔性的通量集中器组件,其中所述通量集中器被模制成具有宽度尺寸、厚度尺寸和高度尺寸的形状;

所述高度尺寸和所述宽度尺寸中的至少一个是所述厚度尺寸的 25 倍或者大于所述厚度尺寸的 25 倍;并且

其中所述通量集中器具有 500mT 或者更大的饱和度。

14. 如权利要求 13 所述的柔性的通量集中器组件,所述通量集中器具有大于自由空间渗透性 15 倍的渗透性。

15. 如权利要求 13 所述的柔性的通量集中器组件,所述通量集中器具有 1S/m 或者更小的电导率。

16. 如权利要求 13 所述的柔性的通量集中器组件,所述厚度是 1mm 或者更小。

17. 一种制造柔性的通量集中器组件的方法,其包括:

提供具有厚度和表面的通量集中器;

用刻痕图案来刻痕所述通量集中器,其中所述刻痕图案影响所述柔性的通量集中器响应于折弯而打断的地方;和

将层压件且粘合性地紧固到所述通量集中器的所述表面的至少一部分上,其中在所述层压件和所述通量集中器的所述表面的所述至少一部分之间形成了结合,从而响应于在所述刻痕图案的至少一部分处或附近打断所述通量集中器,所述结合和所述层压件将所述通量集中器的多个片块保持在一起。

18. 如权利要求 17 所述的制造柔性的通量集中器组件的方法,其中所述层压件围绕所述通量集中器。

19. 如权利要求 17 所述的制造柔性的通量集中器组件的方法,其中将所述通量集中器打断不会显著地影响所述通量集中器的磁性能。

20. 如权利要求 17 所述的制造柔性的通量集中器组件的方法,其包括:

将线圈嵌入在所述通量集中器中,其中所述线圈的一个侧面与所述通量集中器的所述表面齐平而形成了暴露的侧面,并且所述线圈的另一个侧面被嵌入在所述通量集中器的所述厚度内而形成了未暴露的侧面,其中所述线圈能够在所述暴露的侧面上感应耦合,并且不能够在所述未暴露的侧面上感应耦合。

21. 如权利要求 17 所述的制造柔性的通量集中器组件的方法,其中所述刻痕图案影响所述通量集中器以使其响应于折弯而打断成多个相同尺寸的片块。

通量集中器和制作磁通量集中器的方法

技术领域

[0001] 本发明总体上涉及磁通量集中器和制造磁通量集中器的方法。

背景技术

[0002] 磁通量集中器（有时被称为通量引导件、通量聚焦器、通量增强器、通量分流器、通量控制器、通量反射器以及其它名称）一般已公知并且已在感应加热和感应电能传输这些应用中使用。通量集中器增强了在某些区域中的磁场，并且能协助增加电能传输或热传输中的效率。在没有集中器的情况下，磁场很有可能扩散，并且与任何导电的周围事物相交叉。在某些情况下，磁通量防护罩可以是一种磁通量集中器。

[0003] 有时将软磁材料（即，在施加外部磁场时被磁化的材料）用于制造通量集中器中。软磁材料具有随机布置的磁畴。通过施加外部磁场可暂时布置磁畴。

[0004] 用在制造通量集中器的最普通软磁材料之一是铁素体。铁素体通量集中器是致密结构，其通常通过将氧化铁与一种或多种金属（诸如镍、锌或锰等）的氧化物或碳酸盐混合制成。由于金属氧化物（包括一些不含铁的金属氧化物）的众多组合物，因此“铁素体”的种类是极其多样的。通常，它们被压制，然后于高温下在窑中烧结并且机加工成适用于线圈的几何形状。铁素体一般具有很高的磁导率（通常超过 $\mu_r = 2000$ ）和低饱和通量密度（通常在 3000 至 4000 高斯之间）。铁素体通量集中器的主要缺陷在于当被制造呈薄横截面时它们时常是脆的且趋于歪斜 (warp)。铁素体也通常具有低饱和通量密度并且因此容易变为饱和，并且由此比空气在其它磁场面前不再更显著地可对磁场进行渗透，这在一些应用中可能是不期望的。铁素体通量集中器有时被制作得更厚来对脆性及低饱和通量密度进行补偿。铁素体通量集中器可被机加工得更薄，可是硬度会使其变得困难。然而，机加工薄部件将不能解决饱和问题或体积的可制造性。而且，机加工部件可使得批量生产昂贵并且困难。

[0005] 有时被用在制造通量集中器的另一种软磁材料是磁电介质材料 (MDM)。这些材料由软磁材料和电介质材料制成，其充当了颗粒的粘结剂和电绝缘体。MDM 通量集中器以两种形式出现：可成形的和固体的。可成形的 MDM 为油灰状并被期望被模制成配合线圈的几何形状。通过用后续热处理压制金属粉末和粘合剂来生产固体的 MDM。MDM 通量集中器的特性是除了其他以外而基于粘结剂的百分比进行变化的。通常，粘结剂越少则渗透性越高。然而，在传统的布置中，更少的粘结剂转化成了更多的金属相互 (metal on metal) 接触，并且因此在通量集中器的使用期间形成了更多的涡电流 (eddy currents)。尽管 MDM 通量集中器可以制造成具有薄的轮廓，由于变化的粘结剂百分比的竞争效应 (competing effects)，因此难以制造出具有所有期望的磁和热特性的 MDM 通量集中器。

[0006] 诸如手机、mp3 播放机和 PDA 等消费电子器件正趋向于细长的轮廓。同时，对能够接受无线电能的便携装置的需求在不断地增长。适合于与无线充电系统一同使用的电流通量集中器一般太厚，并且因此会明显地增加消费装置的轮廓。相应地，期望一种可制造出具有期望的磁和热特性的、适合于与无线电能传输系统一同使用的薄的通量集中器的方法。

发明内容

[0007] 本发明提供了通量集中器和用于制造通量集中器的方法。在一个实施方式中,该方法包括下列步骤:1)使粉末状软磁材料、粘结剂、溶剂以及一种或多种润滑剂相结合;2)至少将粉末状软磁材料、粘结剂和溶剂以充足的时间进行混合,以便溶解溶剂中的粘结剂来生成混合物;3)使溶剂从混合物中蒸发;4)将混合物模制以形成通量集中器;并且5)将通量集中器固化(cure)。使用适宜类型和数量的材料,所产生的磁通量集中器可被制造成具有适于与无线电能传输系统一同使用的磁和热特性。另外,所产生的磁通量集中器可被可靠地制造成具有与无线电能传输系统相适宜的尺寸。例如,在一个实施方式中,可将磁通量集中器制造成具有大于或等于约500mT的饱和磁感应强度,并且具有约25比1的最小的宽度对厚度尺寸比、或者最小的高度对厚度尺寸比。由于颗粒或聚结物的大小被保持在特定范围内,这些结果(至少部分地)是可实现的。在一些实施方式中,在模制之前,可筛选混合物来控制待被模制的颗粒或聚结物的大小。在一个实施方式中,粉末状软磁材料被聚结并被筛选为在约75微米和430微米之间。在可替换实施方式中,粉末状软磁材料颗粒的大小是天然地在75微米和430微米之间,所以无需形成聚合物并且没有必要进行筛选。

[0008] 制造通量集中器的方法可包括加入外部润滑剂和内部润滑剂。在既包括外部润滑剂又包括内部润滑剂的实施方式中,当混合物填充模具时,外部润滑剂趋于敷膜于(bloom to)聚结混合物的外表面,并且润滑了混合物的流动。外部润滑剂在混合物压缩期间也会有帮助。内部润滑剂趋于润滑各软磁颗粒,其由于在模制工艺期间施加压力而降低了颗粒之间(particle-to-particle)的接触,从而导致在通量集中器的使用期间形成了较少的涡电流。制造工艺可用来有成本效率地批量生产含有少量粘结剂并且展示出合适的磁和热特性的通量集中器。而且,使用该方法可以可靠地实现薄的通量集中器轮廓。在可替换实施方式中,可使用单一的润滑剂。

[0009] 在一个实施方式中,通量集中器的原材料包括了按重量计百分比范围在0.001-2.0的外部润滑剂、按重量计百分比范围在0.005-3.0的内部润滑剂、按重量计百分比范围在0.5-3.0的粘结剂、以及软磁材料的剩余部分。在使用溶剂的实施方式中,溶剂的量取决于所选择的粘结剂和溶剂。在当前实施方式中,使用了粘结剂10-20倍之间的溶剂。在一个实施方式中,在制造期间,可生成多个由润滑剂、软磁颗粒和粘结剂颗粒组成的聚结物。在加入溶剂的实施方式中,基本上所有的溶剂能在制造期间被蒸发。该制造方法生产出具有700微米和700微米以下聚结物的混合物。在压实(compaction)工艺期间可将混合物筛选成更窄的颗粒大小范围以有助于材料的均匀性。在当前实施方式中,筛选的行为将聚结物的大小分离至在约75微米和430微米之间。在一个实施方式中,通量集中器具有下列磁、热和物理特性:大于自由空间渗透性15倍的渗透性、大于30mT的饱和度、小于1S/m的电导率以及小于1mm的厚度。这样的通量集中器可使用本发明用于制造通量集中器的方法来制造。在可替换实施方式中,可制造出通量集中器以实现不同的磁、热和物理特性,其取决于应用。

[0010] 通量集中器可被层压(laminated)并且打断成多个片块(piece),这使得通量集中器更为柔性。将通量集中器打断不会显著地影响磁性能。由于粘结剂的渗透性非常类似于空气的渗透性,在片段(fraction)之间加入极小的空气间隙与加入更多粘结剂相比不

会有显著的不同。

[0011] 参考实施方式和附图说明可以更完整地理解并认识到本发明的这些以及其它特征。

附图说明

- [0012] 图 1 为图示了制造通量集中器方法的一个实施方式的流程图。
- [0013] 图 2 为图示了制造通量集中器方法的另一个实施方式的流程图。
- [0014] 图 3 为用于压缩模制根据本发明实施方式的通量集中器的示范性压制的图示说明。
- [0015] 图 4 为在通量集中器一个实施方式内的嵌入线圈的俯视图和侧横截面视图。
- [0016] 图 5 为包括了嵌入磁体的通量集中器的实施方式的俯视图。
- [0017] 图 6 为具有嵌入在通量集中器内的磁体、以及将该磁体和通量集中器分离的绝缘体的实施方式的俯视图。
- [0018] 图 7 为具有嵌入磁体的层压的通量集中器的侧横截面视图。
- [0019] 图 8 为层压的柔性通量集中器的透视图。
- [0020] 图 9 为双层压的通量集中器的分解视图和侧组合视图。
- [0021] 图 10 为示出了用于生成柔性通量集中器的方法的代表性视图。
- [0022] 图 11 为示出了使用滚筒用来生成柔性通量集中器的方法的代表性视图。
- [0023] 图 12 为示出了使用滚筒用来生成柔性通量集中器的方法的代表性视图。
- [0024] 图 13 图示了两个代表性视图，它们示出了用于两种不同的通量集中器的断点。
- [0025] 图 14 和图 15 为示出了通过刻痕和层压用来生成柔性通量集中器的方法的代表性视图。
- [0026] 图 16 为示出了通过用模板 (pattern) 来模制集中器以生成柔性通量集中器的方法的代表性视图。
- [0027] 图 17 示出了具有不规则模板的通量集中器的代表性透视图，其考虑到通量集中器的多种区域中的多种柔性水平。
- [0028] 图 18A 示出了嵌入在压缩模制出的磁通量集中器中的迹线 (trace) 的透视图。
- [0029] 图 18B 示出了迹线的透视图。
- [0030] 图 18C 示出了嵌入在压缩模制出的磁通量集中器中的迹线的俯视图，该磁通量集中器被连接至模压线圈 (stamped coil)，该模压线圈被安装在压缩模制的磁通量集中器的表面上。
- [0031] 图 18D 示出了图 18C 的截面视图。
- [0032] 图 19 示出了迹线的可替换实施方式的透视图。
- [0033] 图 20 示出了嵌入在压缩模制出的磁通量集中器中的迹线的可替换实施方式。
- [0034] 图 21 示出了无线电能模块一个实施方式的俯视图。
- [0035] 图 22 示出了图 21 的无线电能模块的仰视图。
- [0036] 图 23 示出了具有线圈阵列的无线电能模块的实施方式的俯视图。
- [0037] 图 24 示出了具有多层线圈阵列的无线电能模块的另一个实施方式的俯视图。
- [0038] 图 25 示出了具有共同模制的迹线的通量集中器的实施方式的透视图。

具体实施方式

[0039] 图 1 中图示了用于制造根据本发明实施方式的通量集中器的方法的流程图,并且在总体上被标示为 100。方法 100 一般包括这些步骤:1) 使软磁粉末、粘结剂、溶剂、润滑剂(例如,外部的和/或内部的润滑剂)相结合 102;2) 至少使软磁粉末、粘结剂、溶剂、润滑剂混合 104 充足的时间来溶解粘结剂中的粘结剂以生成混合物;3) 例如通过加热和/或对该混合物应用真空而使溶剂蒸发 106;4) 模制该混合物以形成通量集中器;以及 5) 在足以固化所述粘结剂的温度中固化 110 通量集中器。尽管材料都是被结合的,但是不需要刚好在混合之前或同时发生结合。例如,在溶剂被蒸发之前的任何时候,润滑剂(多种润滑剂)可与其它材料相结合。在具有超过一种润滑剂的实施方式中,可在混合之前或之后加入一些润滑剂。在一些实施方式中,例如通过筛选,可以在将混合物注入模具型腔之前控制混合物的颗粒大小。控制混合物的颗粒大小可包括控制混合物中聚结物的大小。

[0040] 本质上可使用任何软磁材料来制造通量集中器。在当前实施方式中,使用了铁粉末,因为它在用于与感应电能传输系统连接的频带中具有期望的磁特性。两种适合的铁粉末的实例为 Ancorsteel 1000C 和羰基(carbonyl)铁粉末。当被绝缘或与粘结剂一同使用时,Ancorsteel 1000C 和羰基铁粉末在 50kHz 至 500kHz 频带中都具有相对高的渗透性、相对高的饱和度以及相对低的磁损耗。Ancorsteel 1000C 可从 Hoeganaes 公司获得,并且羰基铁粉末可从 BASF 公司获得。软磁材料的颗粒大小可取决于应用而变化。在使用羰基铁粉末的实施方式中,羰基铁粉末的颗粒范围通常从 0.5 微米到 500 微米。在使用 Ancorsteel1000C 的实施方式中,Ancorsteel 1000C 的颗粒范围通常从 75 微米到 430 微米。由于成本原因或者为了实现通量集中器的某些期望的性能,可在不同实施方式中使用其它类型的铁粉末或者不同类型铁粉末的结合物。

[0041] 在可替换实施方式中,可使用其它的软磁材料,诸如软磁合金、绝缘金属颗粒或粉末状铁素体。可使用的软磁合金的具体实例包括了铁镍钼磁粉(Moly Permalloy Powder)、透磁合金(Permalloy)以及铝硅铁粉(Sendust)。使用软磁合金可在没有降低通量集中器性能的情况下能够使用较高的粘结剂百分比。绝缘金属的一个实例为被磷酸盐(phosphate)涂覆的铁。绝缘可降低涡电流和腐蚀。可适当地修改固化工艺来避免无意地消除绝缘,在固化期间绝缘可能会受到所用温度的侵害。

[0042] 颗粒分布可基于具体应用进行定制。在当前实施方式中,使用了单一类型的软磁材料和粘结剂,但是在可替换实施方式中,可使用双模态或其它定制的颗粒分布。例如,铁素体粉末和羰基铁粉末的结合可被用来制造具有用于特定应用的期望特性的通量集中器。在可替换实施方式中,其它的粉末状材料的融合物可能是合适的,例如高渗透性的软磁粉末的结合物。

[0043] 本质上可使用能将软磁材料粘结在一起以形成通量集中器的任何粘结剂来制造通量集中器。粘结剂是用于将混合物中的材料粘结在一起的材料。适合于在本发明中使用的粘结剂的实例包括热固聚合物、热塑性聚合物、硅酮聚合物(silicone polymers)、无机材料(诸如铝、二氧化硅或硅酸盐)、或者能将软磁材料粘结在一起以形成通量集中器的任何其它粘结剂。热固聚合物的实例包括环氧化物(有时被称为环氧树脂)、酚醛塑料(Bakelite)和福米卡塑料贴面(Formica)。环氧化物为在当前实施方式中使用的粘结剂。

环氧化物形成自环氧树脂与聚胺的反应。当前的实施方式使用了潜在的固化环氧树脂。当两个单体结合时,它在室温下为固体,但是直到被加热才会固化成交联的树脂。如在当前实施方式中,树脂和触媒可在混合之前同时与其它材料预结合或结合。

[0044] 溶剂可作为载体使用来分散在软磁粉末内的粘结剂。在当前实施方式中,丙酮被用作溶剂以便溶解环氧树脂粘结剂。在可替换实施方式中,可使用不同的溶剂来分散粘结剂。在当前实施方式中,一旦将粘结剂溶解在溶剂中并且在工艺中进行混合,该溶剂就被蒸发。

[0045] 将小百分比的粘结剂与粉末状软磁材料进行混合,可致使聚结物形成在混合物中。精细粉末流动不佳,并且当被注入模具型腔中时,精细颗粒趋于阻挡(trap)空气。聚结物相对于精细粉末可具有更好的填充和流动特性。取决于混合物的组成,聚结物的大小可处于期望的范围内,例如在 75 微米与 430 微米之间。取决于混合物的组成,可有益于筛选混合物以去除更小的聚结物和/或更小的颗粒,并且进一步改善填充和流动特性。例如,可使用筛选来获取大小在 75 微米与 430 微米之间的聚结物。另外,某些聚结物能给所产生的通量集中器提供某些磁、热和机械性能。

[0046] 在使用外部润滑剂的实施方式中,外部润滑剂可在聚结的颗粒之间提供润滑,这使得混合物流动得更快并且填充模制型腔更具均匀性。当溶剂蒸发时,外部润滑剂敷膜于聚结物的外表面并提供润滑,因而增加了混合物的流动且将它转换成自由流动粉末。

[0047] 可选择与一些或全部的软磁材料、粘结剂及溶剂具有有限兼容性的外部润滑剂。在一个实施方式中,在混合之前或混合期间,外部润滑剂可与软磁材料、粘结剂和溶剂相结合。在可替换实施方式中,在混合之后、但在模制步骤之前,可加入外部润滑剂。在混合步骤之前,聚二甲基硅氧烷可作为外部润滑剂使用,并且可与其它材料相结合。在可替换实施方式中,可使用不同的外部润滑剂,例如矿物油或植物油。

[0048] 在使用内部润滑剂的实施方式中,该内部润滑剂可降低在已完成的通量集中器中的软磁颗粒到颗粒之间的电导率,并且可在模制操作期间在金属或铁素体颗粒之间提供润滑。即,内部润滑剂可降低在通量集中器中形成的涡电流。合适的内部润滑剂的实例包括金属皂(诸如硬脂酸锌)和粉末状蜡。内部润滑剂不会敷膜于聚结物的外侧。作为代替,内部润滑剂渗透了聚结物并且到达软磁粉末颗粒的中间,这减少了会导致附加电损耗的颗粒碰撞的机率。

[0049] 在制造工艺期间所使用的润滑剂,内部润滑剂和外部润滑剂二者都可使用较少的粘结剂,同时提供了相似或改善的磁和热特性。

[0050] 可将这些材料在常规的混合器中进行混合,并且本质上可使用能充分彻底且以充足时间混合来溶解溶剂中粘结剂的任何混合技术。整个混合工艺过程中,可以按照不同次序且在不同时间加入材料。

[0051] 可以使用多种蒸发技术以便蒸发溶剂。在当前实施方式中,混合器包括套管(jacket),其中可传送热水或蒸汽来加热该混合器中的材料。当前实施方式的混合器也包括有用来在混合器内获得真空的泵。当溶剂蒸发时,混合物变干而成为粉末,其中可有粘结剂颗粒和软磁材料颗粒的聚结物。

[0052] 粉末可被直接注入用来模制的型腔中,或被筛选以控制颗粒及/或聚结物的大小。在一个实施方式中,粉末被处理直到足够量的溶剂被蒸发从而使得粉末变干并且可被

筛选。在可替换实施方式中,筛选步骤被略过,并且较少的精炼粉末可注入模具中。

[0053] 图 2 中图示了用于制造通量集中器方法的另一个实施方式的流程图,并且总体上被标示为 200。该方法包括这些步骤:1) 将软磁粉末加至混合器 202;2) 将粘结剂添加至混合器 204;3) 将溶剂加至混合器 206;4) 将外部润滑剂加至混合器 208;5) 将内部润滑剂加至混合器 210;6) 将这些材料混合直到溶剂溶解了粘结剂 212;7) 使溶剂蒸发 214;8) 筛选混合物 216 以控制颗粒大小 216;9) 压缩模制以形成通量集中器 218;10) 使通量集中器弹出 220;以及 11) 固化通量集中器 222。在用于制作通量集中器方法的该实施方式和图 1 实施方式之间的一个区别在于:混合物被筛选以控制颗粒大小。筛选可以是能去除太大和/或太小的颗粒的一个或两个阶段工艺。

[0054] 混合物可被筛选以去除大于阈值、小于阈值或两者皆有的颗粒或聚结物。窄的颗粒分布通常将会更稳定且更可靠地填充模具。在一个实施方式中,在指定阈值之下的粉末状颗粒和聚结物被去除。去除精细颗粒致使在填充模具时更好地增加了均匀性。通过较小的颗粒可以更容易地阻挡空气,所以将它们从混合物中去除可对模具填充操作有益。

[0055] 在一个实施方式中,如有需要,可通过 40 目美国标准筛(430 微米)去除大颗粒和聚结物,并且通过 200 目美国标准筛(75 微米)去除精细颗粒。聚结物可被磨碎或者压碎大并被加至混合物,较小颗粒可循环回到未来批量中。在可替换实施方式中,可使用不同大小的目或者其它筛选装置来获得混合物中不同大小的颗粒。

[0056] 各种不同的技术可被用于模制混合物以形成通量集中器。在当前实施方式中,混合物可被压缩模制。图 3 中图示了用于压缩模制的示范性的压机 300。通过可互换的模具可模制出简单或复杂的形状,可互换的模具可以连同模具型腔 302 一起使用。在当前实施方式中呈粉末为形式的混合物被注入压缩模具 304 的型腔 302 中。在使用外部润滑剂的实施方式中,外部润滑剂协助确保聚结物流动并填充压缩模具。总体而言,粉末是按照体积进行度量进入模具的,并且通过重力填充。通常,压机 300 被保持在室温下,但是在可替换实施方式中,可加热模具。在执行压缩时,上模 306 被带向下并压制粉末来形成固体零件。在当前实施方式中,压力变化可从每平方英寸约 10 吨至每平方英寸 50 吨。在可替换实施方式中,取决于应用而可以增加或者减少压力。

[0057] 在压缩期间,压力施加于聚结物、以及聚结物内的软磁材料颗粒。在使用内部润滑剂的实施方式中,当软磁材料的各颗粒被压缩时,内部润滑剂帮助它们移动。这可以帮助生产具有增强的密度和压缩性、在已完成零件中减小的变形和感应应力的零件。所产生的通量集中器可以比那些使用现有技术生产的通量集中器提供更好的性能特性。

[0058] 尽管使用了压缩模制来实施当前的方法,但是可以使用压缩模制的替换物。例如,挤压技术(诸如柱塞挤压)、冲压或 Ragan 技术公司。高剪切压制是可用于替代压缩模制的技术的所有实例。

[0059] 一旦压缩模制结束,通量集中器可从模具中弹出。在弹出之前或之后,可固化通量集中器或者应用其它的后处理工艺。许多后处理对于完成通量集中器可能是合适的。在当前实施方式中,将约 350 华氏摄氏度的温度应用于通量集中器以便固化粘结剂。在可替换实施方式中,零件可通过加热的模具被部分地固化,接着从模具弹出之后得到最终固化。可能会有其它的后处理,诸如热激活、低温固化、烘干、湿固化、UV 固化、辐射固化或树脂浸渍。如果合适的话,树脂浸渍是一种用溶解在溶剂中的粘结剂树脂来浸涂或涂镀通量集中器的

工艺。通量集中器的多孔部分它们用粘结剂树脂来填充。溶剂被蒸发,留下树脂从而给予通量集中器附加的强度。取决于粘结剂树脂,可将加热工艺用于固化粘结剂。树脂浸渍可以有利的增加通量集中器的强度或者减少随着时间发生的金属腐蚀量。

[0060] 如图 4 中所示,在压缩模制期间,线圈 402 可被嵌入通量集中器 400 中以便减少 z -高度(与堆叠在通量集中器的顶部上的线圈相比)并且增加通量集中器的总体强度。为了嵌入与表面齐平的线圈,可将线圈置于模具型腔的底部中,然后可将软磁材料混合物置入带有线圈的型腔中。在压缩模制之后,所产生的通量集中器包括了暴露的且与通量集中器表面齐平的嵌入线圈。嵌入线圈 402 与通量集中器的顶面齐平,这允许感应耦合发生在该暴露侧面上。即,线圈能被使用作为感应电能传输系统中的初级线圈或次级线圈,其中通量可以从该侧面上的嵌入线圈传输出、或者传输至该侧面上的嵌入线圈,这取决于是否线圈被用作初级线圈或次级线圈。通量集中器的较薄截面不旨在感应耦合,而是旨在集中场(field)以增强感应耦合。

[0061] 在当前实施方式中,嵌入线圈是两层模压线圈。模压线圈是从金属板片剪下的线圈。通过使多次模压的线圈与中间电介质一起分层可以生成多层模压线圈。可使用通路(via)或另一类型的连接来将多个层连接在一起。尽管在所图示的实施方式中模压线圈为两层,在可替换实施方式中,模压线圈可包括附加的层或更少的层。在可替换实施方式中,嵌入线圈可以是线绕式线圈而不是模压线圈,并且线圈可以是单层或超过两层。

[0062] 如图 4 中所示,线圈引线 404 可以伸出被压缩模制的通量集中器之外。在可替换实施方式中,线圈引线可连接至被模压的迹线,该被模压的迹线嵌入在被压缩模制的通量集中器内。图 18A-18D 中示出了嵌入被压缩模制的通量集中器 1800 内被模压的迹线 1802 的一种示范性构造。图 18A-B 示出了被压缩模制的通量集中器 1800 的透视图,该通量集中器 1800 包括有嵌入铜的迹线 1802。如图 18C 所示,迹线包括用于连接至线圈 1809 的衬垫 1804。

[0063] 可将终端 1806 模压以符合通量集中器的边缘。至其它通路部件的连接可以是接触式连接或者焊接。终端可以是直的以便考虑到 Molex 连接器。而且,直的终端可促使直接焊接到 PCBA 上。在模压铜周围/之下所模制的孔 1808 促使冲压出迹线。冲压出的位置 1810 在铜模压中。在模制之后,这个区域被冲压出以打断两个迹线之间的通路。

[0064] 图 18C 提供了嵌入在被压缩模制的通量集中器内并连接至安装了线圈 1809 的表面的迹线构造的俯视图。图 18D 图示了减少的堆叠高度,由于没有经过线圈上方或下方的中心导线,因此可以通过嵌入迹线获得减少的堆叠高度。作为代替,在当前实施方式中,电流由所嵌入的铜迹线承载。当然,在多个可替换实施方式中,也可以用除铜以外的其它金属来承载电流。

[0065] 因为中心导线所要求的迹线被嵌入在磁通量集中器中,嵌入被压缩模制的通量集中器中的被模压的铜迹线可以增加零件的强度、减少总体组件堆叠高度,并且可以通过允许多种终端类型来增加线圈-通量集中器组件的电连接。

[0066] 图 19 图示了可嵌入在被压缩模制的通量集中器中的迹线 1902 的可替换实施方式。迹线 1902 的一部分包括锯齿状或城堡状的边缘 1904,边缘 1904 协助将迹线紧固在被压缩模制的通量集中器中。可使用其它的紧固几何形状以便协助将迹线紧固在被压缩模制的通量集中器中。

[0067] 图 20 图示了改变终端 2006 位置的可替换实施方式。可以调整终端之间的间隔以及它们的位置来配合应用。例如,可以模压终端来形成用于 Molex 连接器或者直接焊至 PCBA 的铲形物。至其它的通路部件的连接可以是接触式连接或者焊接。终端也可以符合通量集中器的边缘。

[0068] 如图 5 中所示,磁体或磁性吸引器 502 可以共同模制、黏合或压制在通量集中器 500 中用于强度和磁性校准。可替换地,可将永久性磁体或磁性吸引器插入件 (insert) 插入后处理。后处理插入可包括将永久性磁体或磁性吸引器安装或粘合在适宜位置的摩擦。可以选择用于通量集中器的材料,用于磁体或磁性吸引器附近的增强性能。例如,具有较高饱和度的通量集中器适合于具有磁体的实施方式中,因为永久性磁体将会局部地降低通量集中器中的饱和度限制。

[0069] 可将永久性磁体或磁性吸引器构造成使得它暴露在旨在用于磁性吸引的表面上。可替换地,可将永久性磁体或磁性吸引器埋在表面下方,但是仍能提供足够的磁性吸引用来校准无线电能传输系统中的远程装置。

[0070] 如图 5 中所图示的,永久性磁体或磁性吸引器可以延伸穿过整个通量集中器。可替换地,永久性磁体或磁性吸引器可以部分地外部延伸至通量集中器或穿过通量集中器的一部分,这取决于对于给定应用所期望的磁性吸引力。

[0071] 如图 6 中所示,通过通量集中器中的绝缘部分 604 可以抵消由永久性磁体引起的被降级的饱和度限制。在所图示的实施方式中,在永久性磁体 602 和通量集中器 600 之间的空气间隙,使得通常由永久性磁体所引起的直流场 (DC field) 的饱和度的影响被最小化。在可替换实施方式中,可使用绝缘体而不是空气。例如,绝缘体可以是迈拉薄膜 (Mylar film) 或者磁导包 (flux guide wrap),诸如非晶态箔或通量反射器。

[0072] 如图 7 所示,可将一层增强材料 706 层压在通量集中器 700 的表面上。为了强度而使用合适的材料来共同模制、挤压或者层压通量集中器。例如,碳纤维、玻璃纤维、石墨烯 (graphene)、塑料或迈拉薄膜、非晶态磁性材料、凯夫拉尔 (Kevlar) 或者不同的合成物可共同模制、挤压或者层压在通量集中器上,或者与通量集中器一起共同模制、挤压或者层压。在另一个实施方式中,可将小段的钢导线切断成如小钢筋、如稳定器,但是对于生成穿过零件的基本上导电基体来说没有那么多。如上面所描述的,可以将可选的永久性磁体或磁性吸引器 702 并入层压的实施方式中。

[0073] 如图 9 中所示,可将材料 902、906 层压在通量集中器 904 的两个表面上,以形成柔性的通量集中器 900。在一些实施方式中,在通量集中器的两个侧面上的层压厚度是相同的,在其它的实施方式中,诸如图 9 中所示出的实施方式,层压可具有不同的厚度。图 9 中所示出的尺寸仅为示范。层压可包括在一个侧面或两个侧面上的粘合剂。例如,在图 9 中,一层膜为单侧面带且其它层的膜为双侧面带。双侧面带具有粘附至通量集中器的一个侧面、以及可粘附至待防护表面的另一个侧面。

[0074] 层压的通量集中器可被分离或打断成多个片块,以便在集中器的不同片块之间形成空气间隙。通过将通量集中器分离成一同层压的多个片块所生成的空气间隙允许通量集中器变得更为柔性。另外,通量集中器中附加的空气间隙不会显著影响通量集中器的性能。例如,在一些实施方式中,由于其形成期间所包括的聚合物材料,在通量集中器中已经存在空气间隙。打断上面所描述的通量集中器一般将会增加空气间隙的量,但是不会采用这样

的方式：其相对于打碎现有技术的铁素体防护罩显著地影响了通量集中器的性能。

[0075] 可将通量集中器打断或分离成均匀或非均匀的片块。在一些实施方式中，将通量集中器分离成总体上均匀大小的部分，诸如图 8 中通量集中器 800 中所示出的总体上均匀大小的正方形。在另一个实施方式中，可将通量集中器分离成非均匀的片块。例如，在图 13 中通量集中器被打断成随机大小的片块，并且在图 17 中通量集中器被打断成不规则图案的不同大小的片块。

[0076] 有许多种不同的技术用于打断或分离通量集中器。一些可能的技术包括：1) 层压和冲压；2) 层压和滚动；3) 刻痕、层压和打断；以及 4) 模制、层压和打断。

[0077] 层压和冲压包括将通量集中器层压，然后将力施加在有图案的模具 1000 上以冲压被层压的通量集中器 900，并且将它打断成多个与有图案的模具相对应的片块。使用这种技术，可生成图 8 中柔性的通量集中器。该模具可包括形成规则重复的几何形状图案（诸如正方形、三角形、六角形等）的脊部。在一个实施方式中，脊部形成了网格状的图案，如图 10 中所示。在多个可替换实施方式中，该模具可包括不规则的图案、或者作为代替而包括无图案或随机图案。

[0078] 层压和滚动包括将通量集中器层压并且使通量集中器 1100 运行通过滚筒系统 1102，以将通量集中器打断成多个片块。如图 11 中所示，在总体上平行于滚筒轴的方向上第一次经过滚筒 1102 打断了通量集中器 1100，这导致了具有总体上平行于滚筒 1104 的轴的裂痕 (fracture) 的通量集中器。在当前实施方式中，通量集中器 1104 从第一次经过滚筒的轴旋转 90 度，然后第二次运行通过滚筒 1102。第二次经过时被赋予磁通量集中器上的裂口 (break) 占主导性地沿着平行于滚筒的轴的方向，这产生了通量集中器 1106。图 11 和图 12 中所示出的裂口或裂痕仅是代表性的并且实际上不会完全平行于滚筒的轴。而且，裂口或裂痕线实际上发生在通量集中器本身中，绘制在层压上的这些线是将发生在通量集中器中裂口的代表。裂口的大小和形状可取决于滚筒系统而变化。如果使用光滑的滚筒系统，通量集中器 1300 可具有随机的裂口 1310，如图 13 中所示。块的大小将至少取决于压力的量、滚筒的半径、滚筒的间隔以及通量集中器经过滚筒的速度。如果滚筒在其表面上具有凸起的图案，那么在滚动工艺期间磁通量集中器可赋予有规则几何形状的图案，例如生产一个如图 8 中所图示的通量集中器。可基于特定的应用来选择几何形状图案的大小和形状。

[0079] 图 14 和图 15 中图示了刻痕、层压和打断的方法。该方法包括在将其层压前首先将通量集中器刻痕，将通量集中器层压，然后将通量集中器打断成多个片块。在图 14 和图 15 中示出了一种将通量集中器 1400 刻痕、层压和打断的方法，其中所刻痕的通量集中器包括有限定了正方形 1402 的刻痕 1404。这些刻痕可包括它们交叉处的断点 1406。在可替换实施方式中，通量集中器的整个表面可被刻痕而没有留下任何断点。而且，在当前实施方式中，通量集中器的一个侧面被刻痕，但在可替换实施方式中，通量集中器的其它侧面也可被刻痕。总体上，刻痕是足够深的以便使得当通量集中器被打断时裂口趋于依循刻痕线。尽管刻痕以总体上正方形图案示出，但是可将刻痕制作成不同的图案。在其它实施方式中，刻痕可由切穿整个通量集中器但留下了所连接材料区段的穿孔 (perforation) 来替代。层压工艺不随上面所描述的其它的实施方式而改变。在当前实施方式中，将被刻痕的通量集中器 1401 层压在一个具有层压 1408 的侧面上并且层压在具有层压 1410 的另一个侧面上。

一旦被层压,柔性的通量集中器 1500 准备投入使用。在使用期间,如果将通量集中器折弯,它将趋于沿着被刻痕的图案打断,这使其有柔性。可替换地,用户可将通量集中器折弯以便沿着刻痕线将通量集中器打断成多个片块。

[0080] 可将通量集中器模制成具有图案,以便促使将其打断成多个片块。图 16 中图示了该技术的代表性附图。模制压机 (mold press) 1602 可包括模具中的脊部 1604,脊部 1604 将刻痕或沟槽赋予到通量集中器中。模具 1606 也可包括将刻痕或沟槽赋予到通量集中器中的脊部 1608。在一些实施方式中,诸如所图示的实施方式,可将通量集中器模制成在两个侧面上都有刻痕线,在可替换实施方式中,可将刻痕线模制在仅一个侧面上,例如通过删除脊部 1604 或脊部 1608 中的一个。在通量集中器被模制之后,可将其层压并打断成多个片块以使其有柔性。

[0081] 在一些实施方式中,可将裂口设计成允许通量集中器以特定的方式成形。例如,在一些实施方式中,通量集中器的块可以是足够小,使得通量集中器能被弯曲成大约弧形的表面。在其它实施方式中,通量集中器可包括不同大小或形状的片块。例如,如图 17 中所示,通过将通量集中器 1700 的第一部段 1702 打断成片块,并且将通量集中器 1700 的第二部段 1704 打断成较小大小的片块,可将通量集中器制造成适应具体的几何形状。当将通量集中器粘合至要防护的不规则表面时,可使用任一种以上技术来制作符合弧形及其它各种形状的通量集中器。

[0082] 以上构造可以帮助增加磁通量集中器的所期望的磁、热或机械性能。这些构造中的一个或多个可与通量集中器结合使用。

[0083] 图 21 和图 22 图示了无线电能模块 2100 的一个实施方式。当前实施方式中的该无线电能模块一般包括线圈 2114、通量集中器 2112、无线电能半导体以及支撑部件 2104、用于在部件和模块之间连接的衬垫 2102、以及用于外部连接的衬垫 2106。可将被嵌入的迹线 2108 用于电连接线圈、衬垫 2102 和衬垫 2106。被嵌入的迹线的构造取决于无线电能模块的设计和功能性而变化。在一个实施方式中,迹线将线圈和衬垫 2102 的引线互相连接,它们被连接至微控制器。被嵌入的迹线也将衬垫 2102 连接至位于外部的衬垫 2106。无线电能模块也可包括构造环状物 2109 和校准元件 2110。在当前实施方式中,线圈 2114 可以被模压,印刷电路板构造,或者是线绕式线圈。线圈可以与如图 4 中所示的磁通量集中器齐平,或与如图 18A-D 中所示的所安装的表面齐平。

[0084] 无线电能模块为制造者提供了简单的方案 (package) 来将无线电能整合进产品中。无线电能模块包括必须要传输或接收无线电能的全部部件和电路。

[0085] 在当前实施方式中,无线电能半导体及支撑部件 2104 包括整流器和微控制器。整流器将从线圈接收的交流电 (AC) 电能转化成直流电 (DC)。微控制器能执行多种不同的功能。例如,微控制器可能能够与感应电源交流、或者调节由无线电能模块所提供电能的量。

[0086] 可使用构造环状物 2109 来手动地改变无线电能模块中线圈的特性。在一种构造中,每一个构造环状物包括高传导路径,并且通过打断环状物可以将附加的电阻加入通路。在名称为“产品监控装置、系统和方法 (Product Monitoring Devices, Systems, and Methods)”、申请号为 61/322,056 的申请中更详细地讨论了该技术。

[0087] 校准元件 2110 在当前的构造中是磁体。在可替换实施方式中,可以一起使用或去除不同的校准元件。该磁体与关联于初级线圈的磁体相配合,以便使线圈排成行并且提供

有效的电能传输。

[0088] 通过将任何待嵌入通量集中器中的部件放置于模具型腔中并压缩模制通量集中器以便嵌入那些部件,以此可制造无线电能模块 2100。在图 21-22 中所示出的实施方式中,线圈 2114、磁体 2110、迹线 2108、构造环状物 2109、衬垫 2102 和衬垫 2106 全部被嵌入通量集中器中。在通量集中器形成之后,将无线电能半导体及支撑部件 2104 连接到衬垫 2102 上。在一些实施方式中,通量集中器可包括凹部,以便使得当无线电能半导体及支撑部件 2104 被连接时它们不会增加无线电能模块的高度。

[0089] 图 23 图示了无线电能模块的可替换实施方式。该实施方式类似于与图 21-22 相关而进行描述的无线电能模块,除了替代单一线圈,在无线电能模块 2312 中包括了三个暴露的线圈 2314。每个线圈可包括校准元件 2310。在图 23 中,每个线圈 2314 被嵌入且与通量集中器的一个表面齐平,这提供了用于传输电能的暴露表面。在可替换实施方式中,线圈可被嵌入且与不同的表面齐平。正如图 22 中所图示的,使用嵌入在无线电能模块中的迹线可使连接贯穿无线电能模块。例如,迹线可在线圈和无线电能半导体及支撑部件之间提供电连接。

[0090] 图 24 图示了一种在图 23 中所示出的无线电能模块的可替换实施方式。在该实施方式中,不是单层线圈阵列,而是多层线圈阵列组件 2012 被嵌入通量集中器中。多层线圈阵列组件 2012 包括被定位在多层阵列中的多个线圈 2014、以及位于一个或多个线圈与通量集中器的表面之间的 PCB 或其它的非传导材料 2016。在一些实施方式中,可包括校准元件 2010。

[0091] 通过将线圈 2014 定位在所期望的图案中并将它们紧固在合适位置,可以生成用于嵌入在通量集中器中的多层线圈阵列组件 2012。可使用 PCB 或其它的非传导材料 2016 在模制期间保护通量集中器避免覆盖混合物。在制造期间,可将整个多层线圈阵列组件 2012 放置在模具型腔中,可将软磁粉末混合物倾倒在多层线圈阵列上并将其压缩模制,以便将整个阵列嵌入在通量集中器中。当通量集中器从模具中弹出时,多层线圈阵列中的一些线圈被暴露并且与通量集中器的表面齐平,其它线圈在通量集中器中被嵌入地更深并且未与通量集中器的表面齐平。然而,被嵌入在通量集中器中更深的线圈的相当一部分不是由与通量集中器表面齐平的线圈覆盖、就是由 PCB 或其它的非传导材料 2016 覆盖,PCB 或非传导材料 2016 是多层线圈阵列组件的一部分。在一些实施方式中,诸如图 24 中所示出的一个,多层线圈阵列组件可从每一个线圈提供导线路径。这样,当被嵌入通量集中器中时,导线可借助于多层线圈阵列组件而选择路径至通量集中器的边缘。导线从该处或由嵌入的迹线、或由外部连接可被连接至位于无线电能模块上的各种无线电能半导体及支撑部件。

[0092] 尽管在已整合了无线电能半导体及支撑部件的无线电能模块的上下文中描述了图 23 和图 24 中的线圈阵列,然而在可替换的非无线电能模块的实施方式中,可使用这些线圈构造作为具有被嵌入线圈阵列的通量集中器。例如,图 4 中所图示被嵌入、齐平的线圈可以由与图 23 和 24 相关而进行描述的单层线圈阵列或多层线圈阵列组件替代。

[0093] 图 25 图示了具有被共同模制的迹线 2502 的通量集中器 2500 的实施方式。在当前实施方式中,迹线上的终端点在磁通量集中器表面的上方突出。终端点可以是压接连接、焊垫或任何其它合适的终端结构。通过将它们放置于并将它们附连到从通量集中器突出的适宜的终端点上,可以校准线圈阵列中的线圈。在可替换实施方式中,线圈阵列组件(类似

于与图 24 有关而在上面进行描述的那个) 和被嵌入的迹线可与通量集中器共同模制。可将来自线圈阵列组件的线圈连接至被嵌入通量集中器中的迹线, 以便选择路径至无线电能半导体及支撑部件。

[0094] 在包括有多层线圈阵列的实施方式中, 来自多层线圈阵列的线圈和引线可使用在 2010 年 8 月 25 日提交的、名称为“无线供电系统和多层垫片组件 (Wireless Power Supply System and Multi-layer Shim Assembly)”的美国临时专利 No. _____ 中所描述的多层垫片组件之一来进行校准和选择路径, 通过引用将其并入本文中。

[0095] 以上描述的是本发明的当前实施方式。在没有背离如所附权利要求中限定的本发明精神和更宽方面的情况下, 可以做出各种替换和修改, 这应当按照包括了等同原则的专利法各原则进行阐释。以单数形式来对元件提出权利要求的任何引用, 例如使用定冠词“一 (a, an)”、“该 (the)”或“所述 (said)”等不解释成将元件限定为单数。

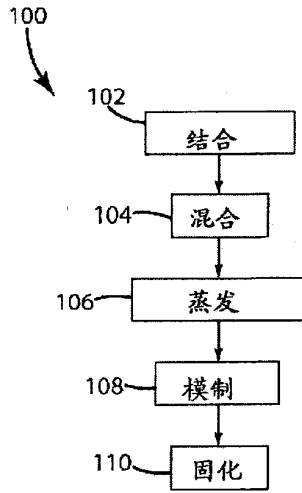


图 1

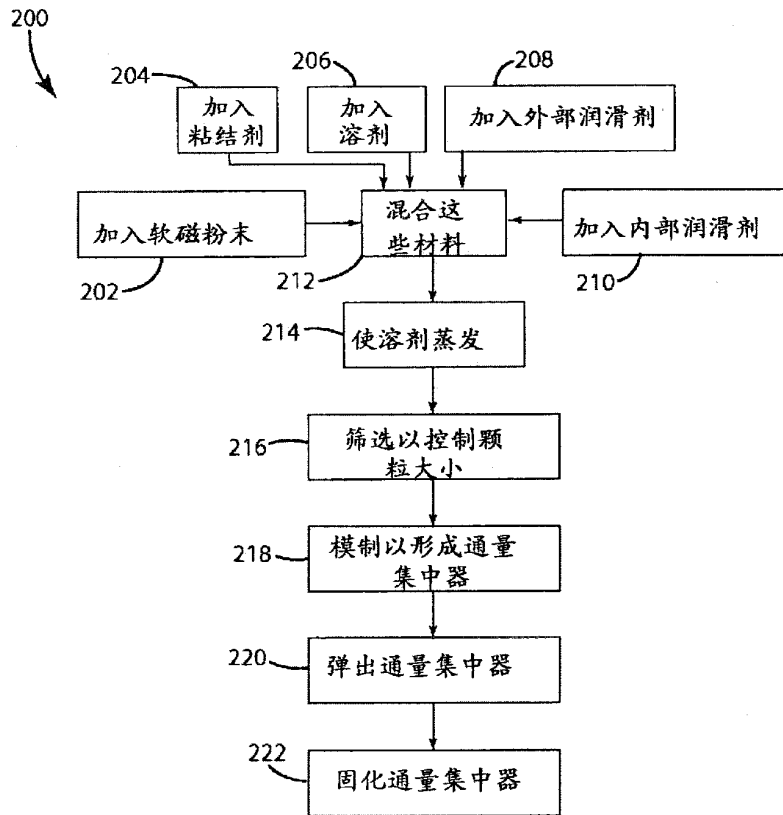


图 2

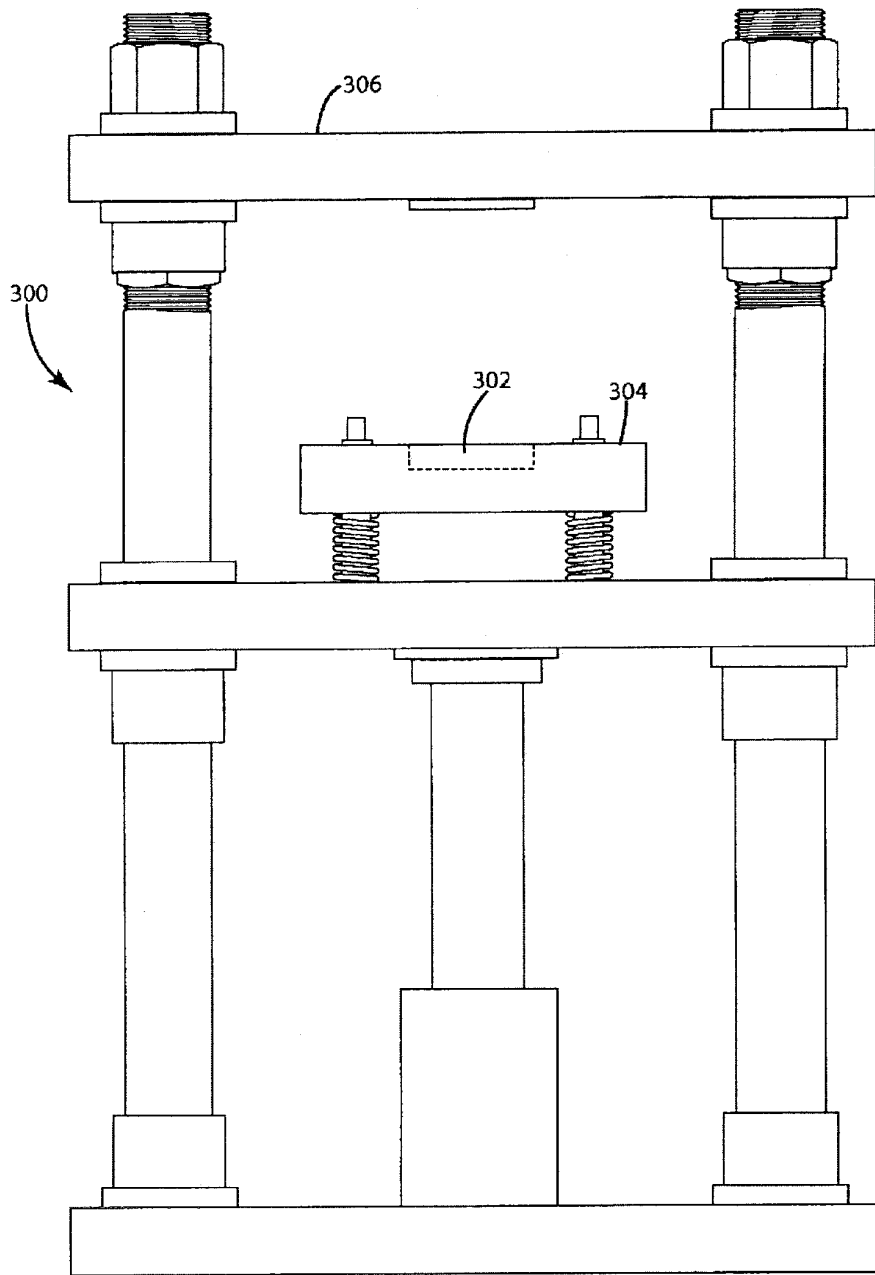


图 3

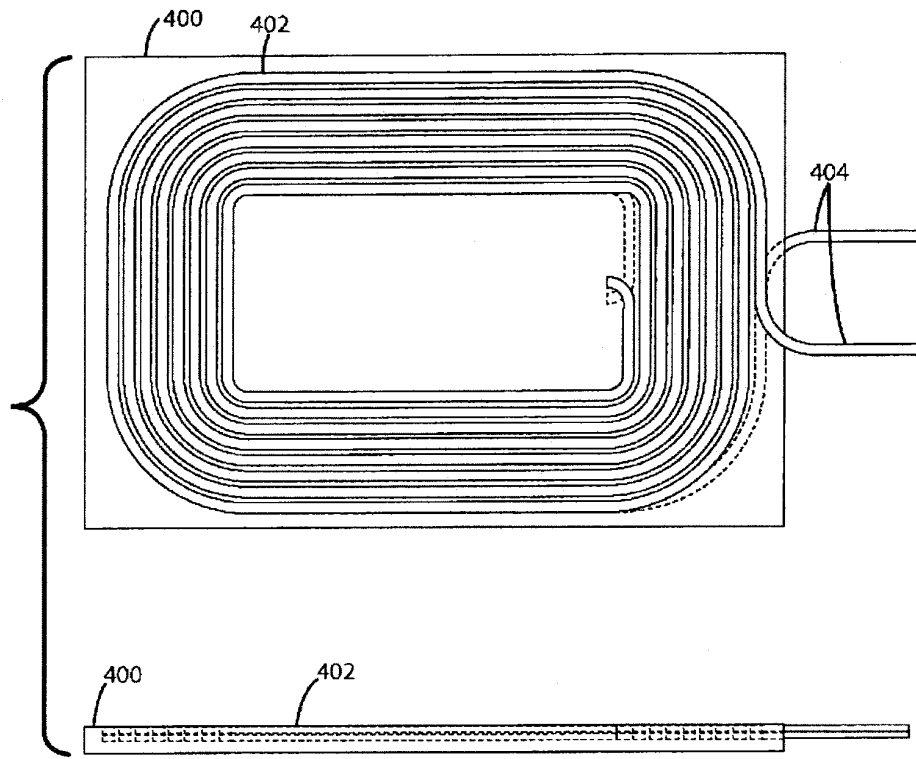


图 4

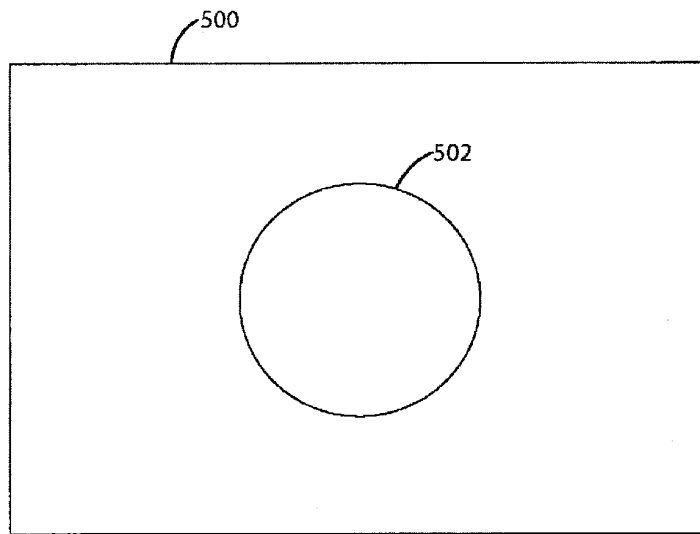


图 5

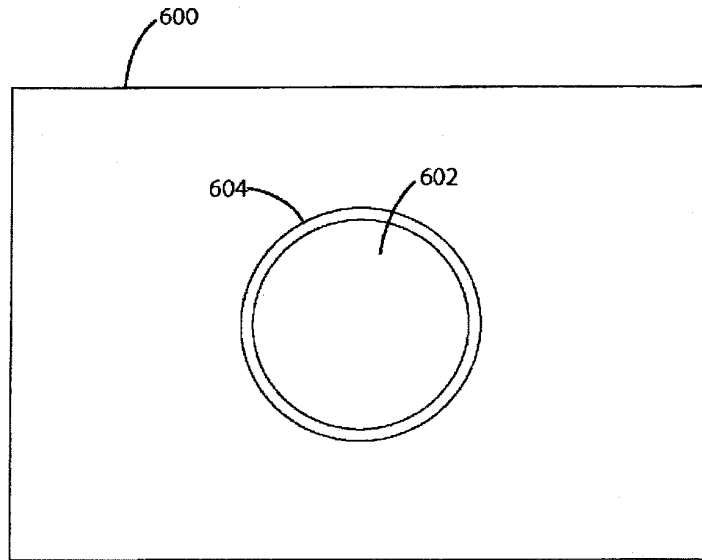


图 6

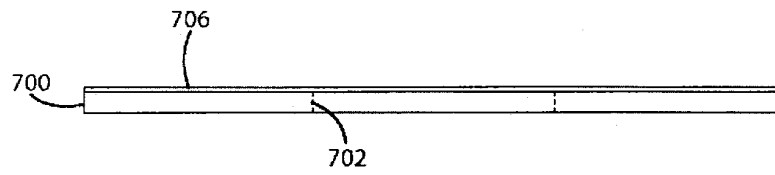


图 7

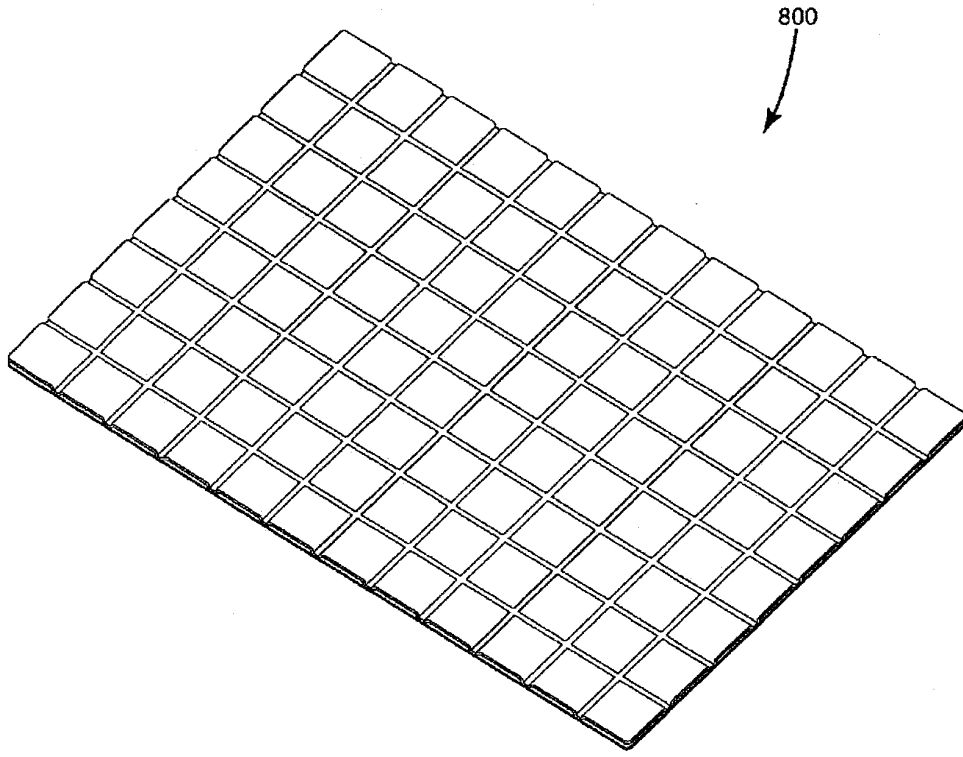


图 8

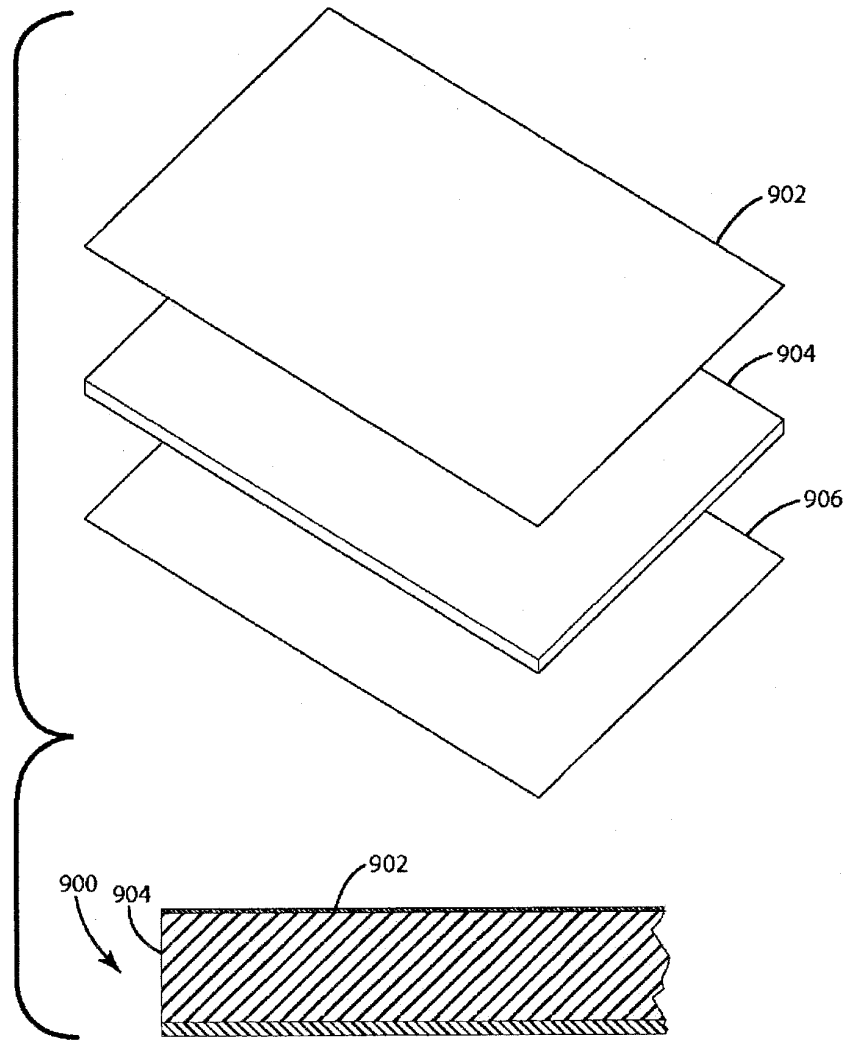


图 9

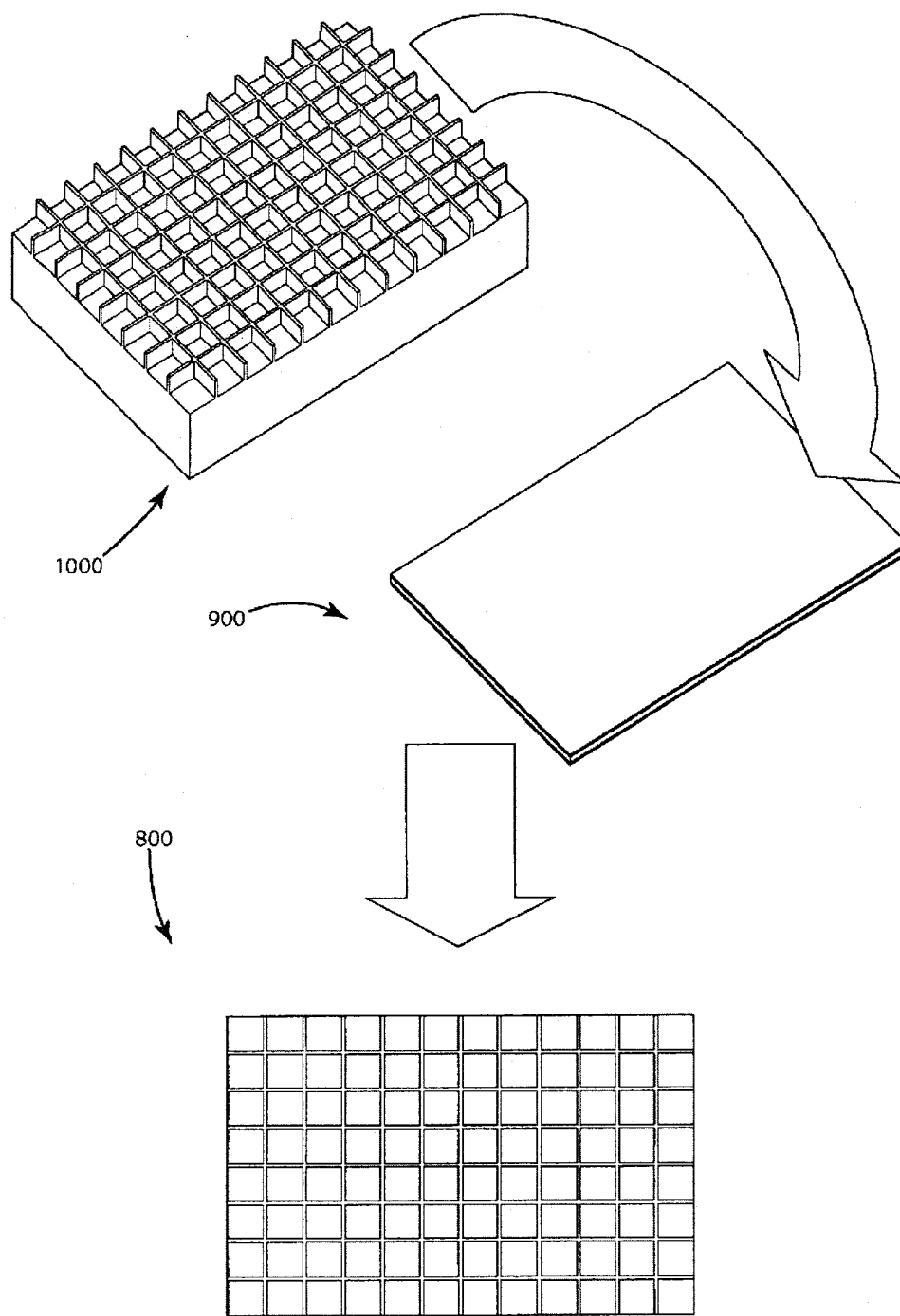


图 10

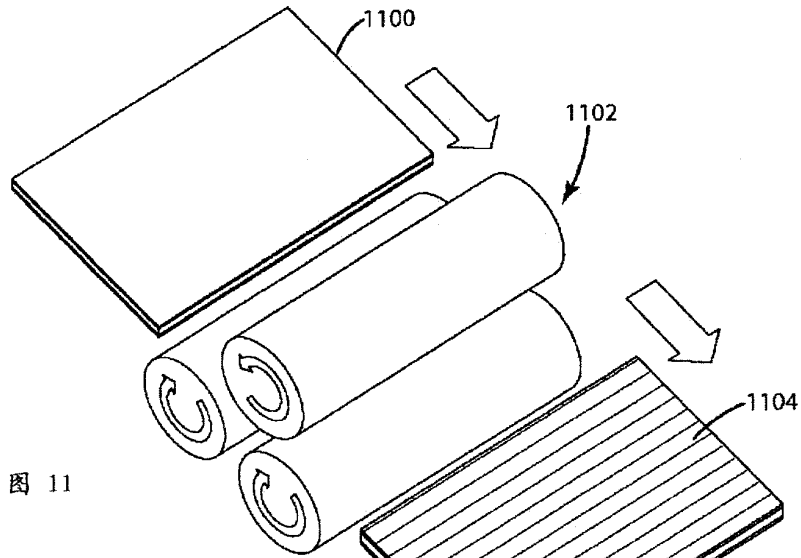


图 11

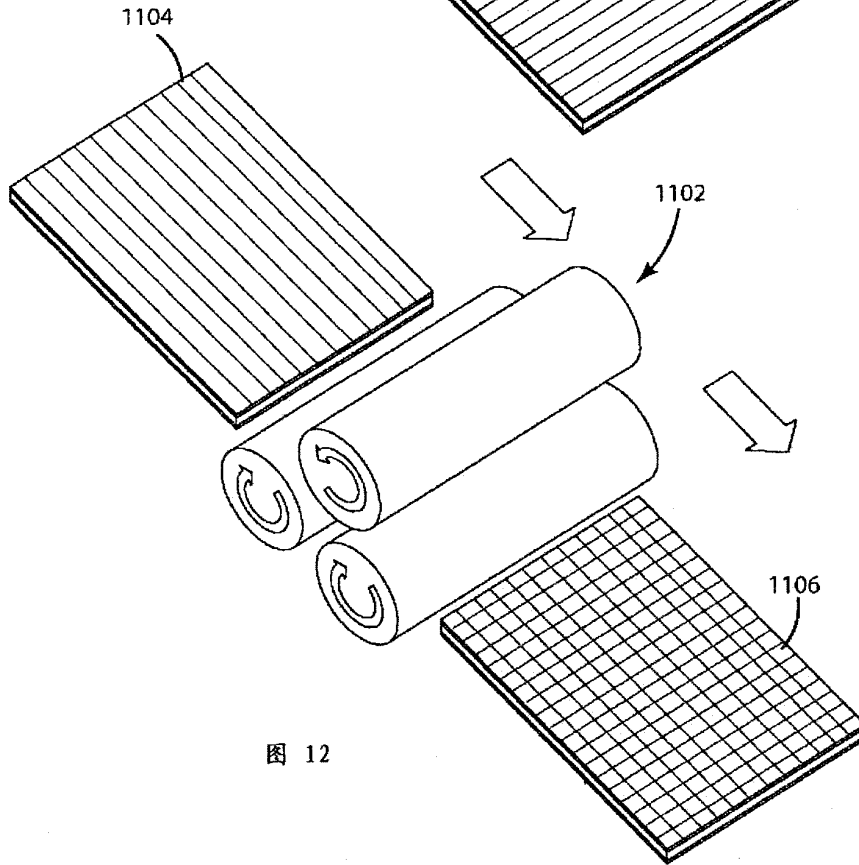


图 12

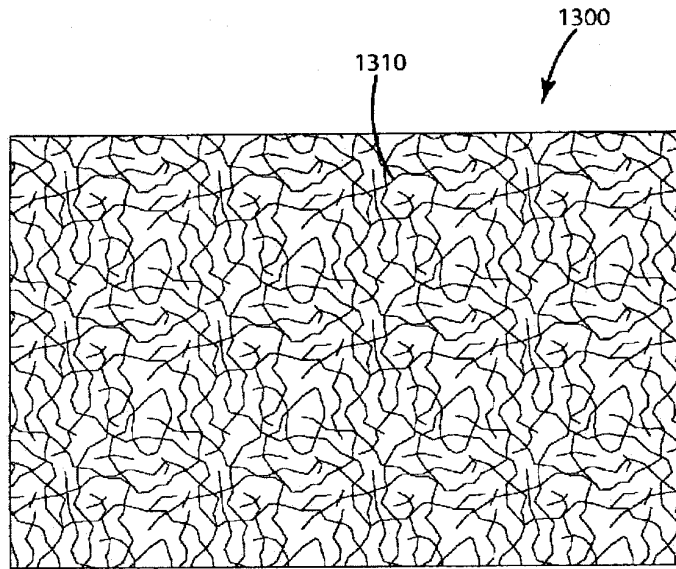


图 13

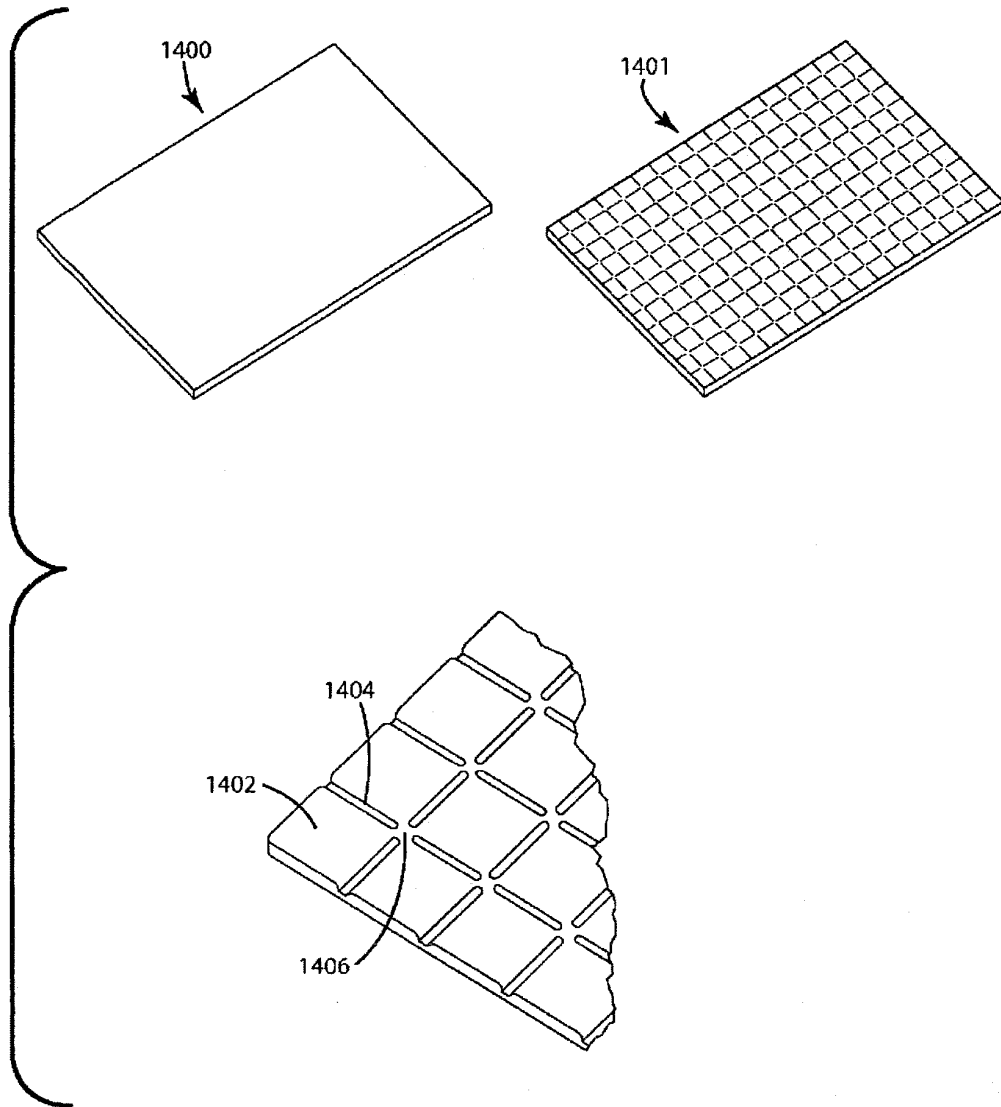


图 14

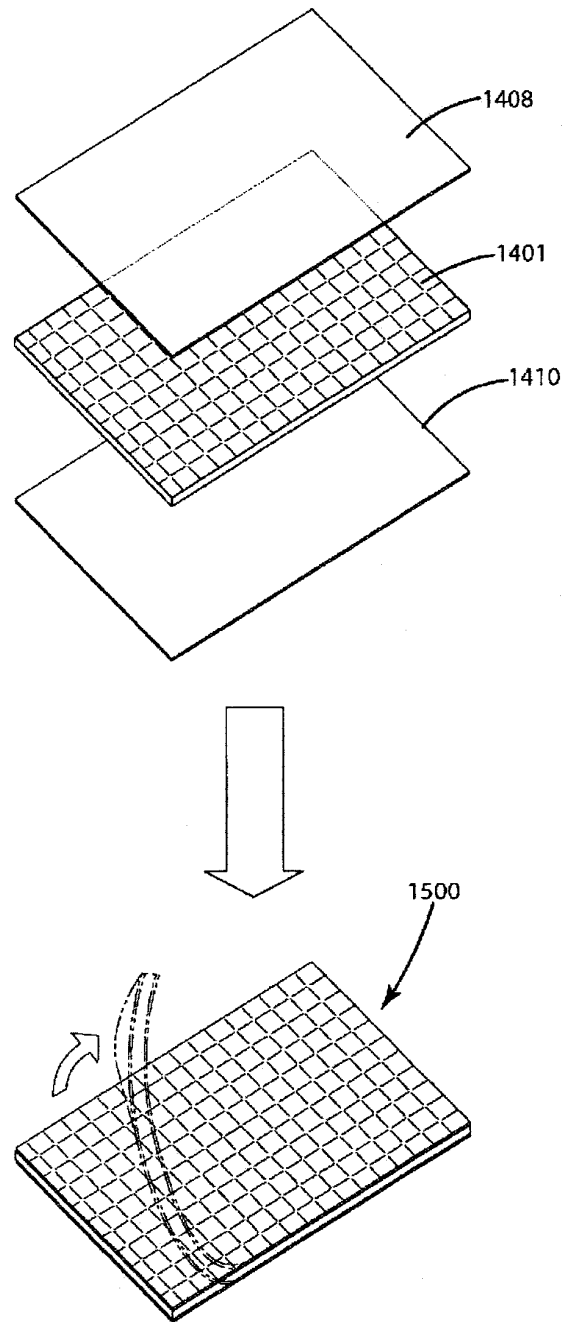


图 15

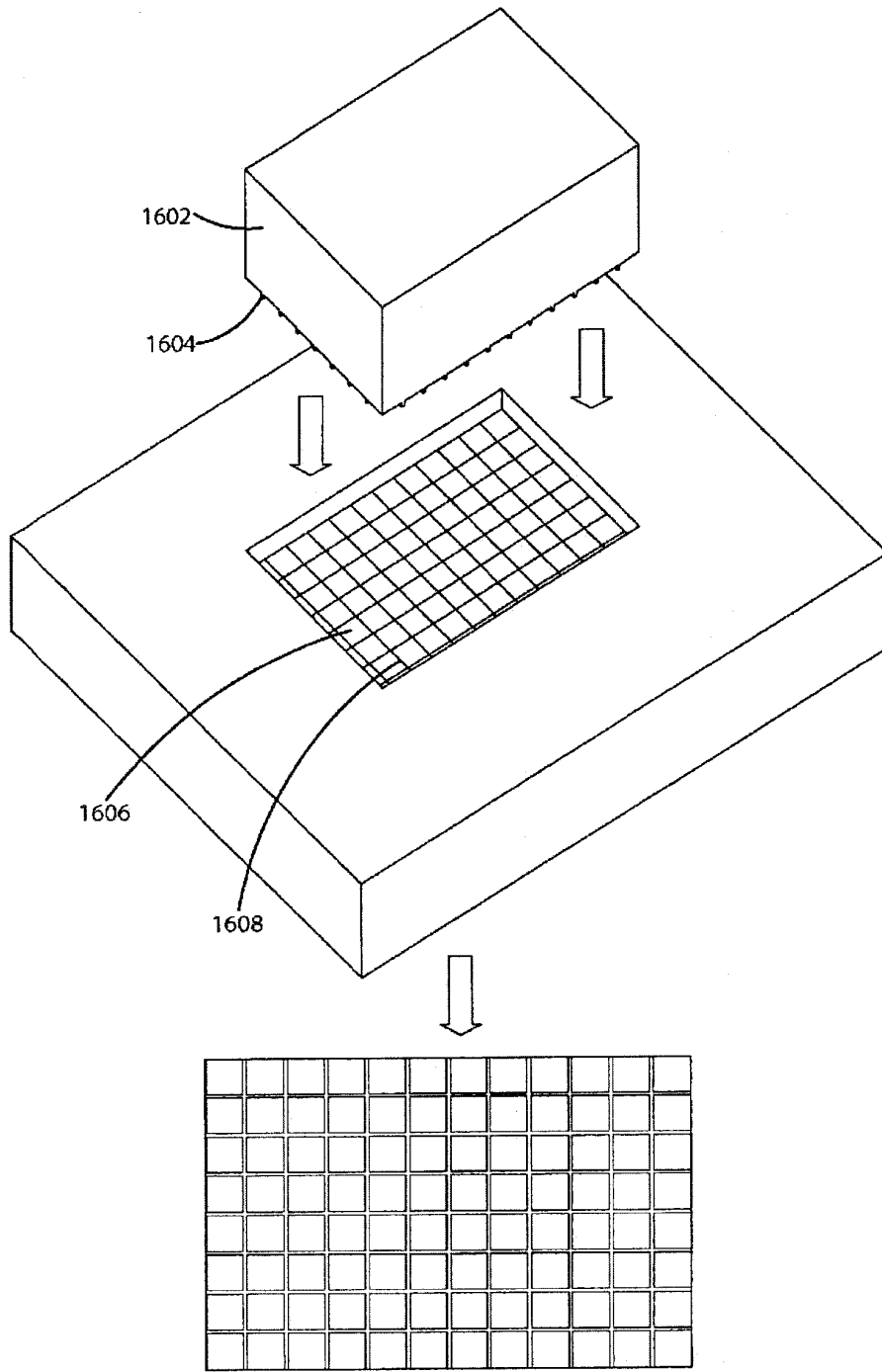


图 16

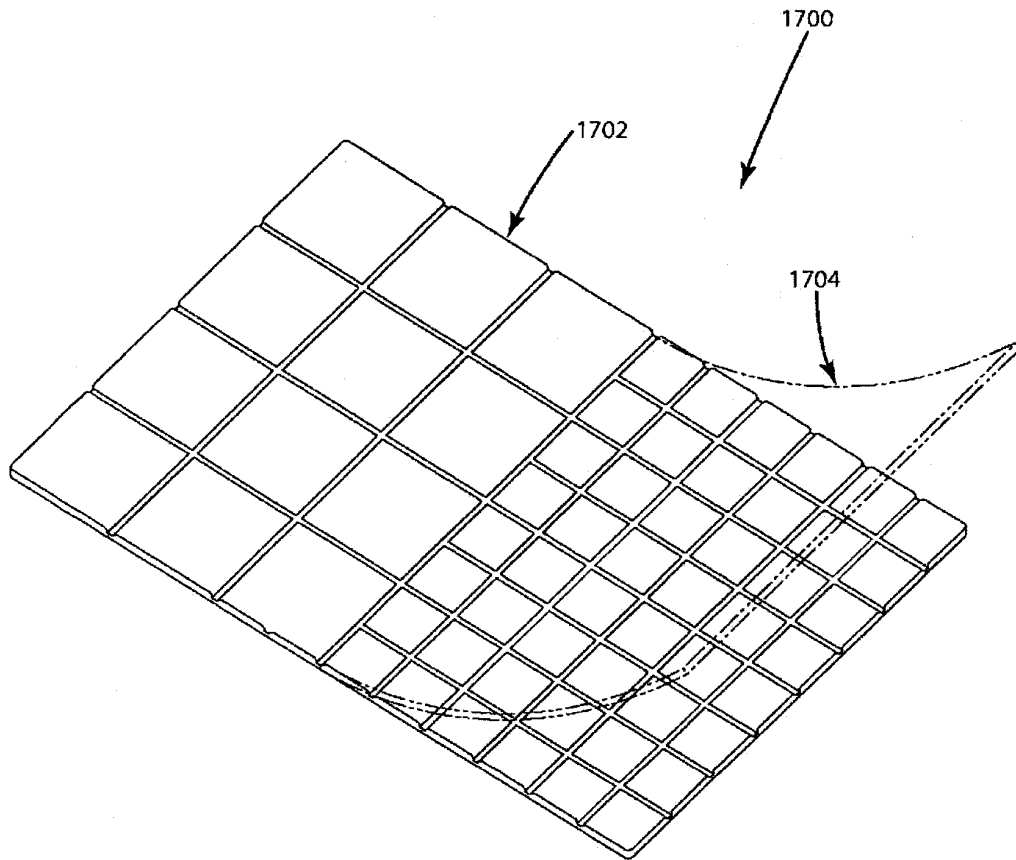


图 17

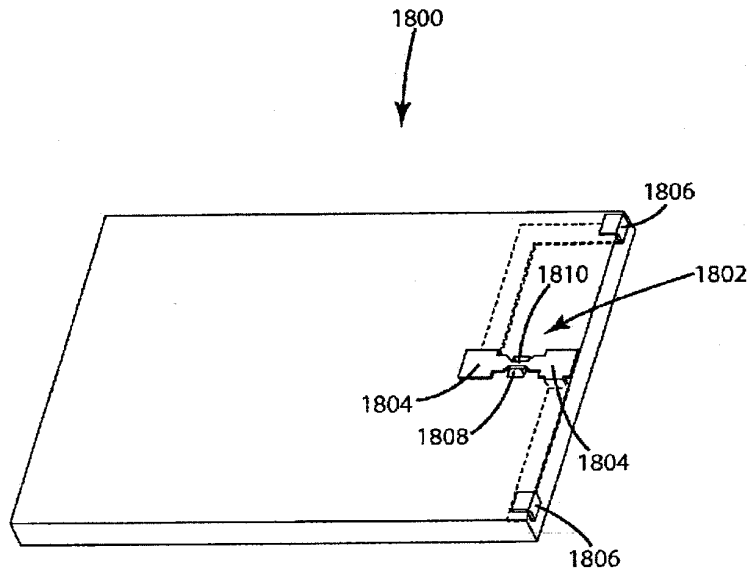


图 18A

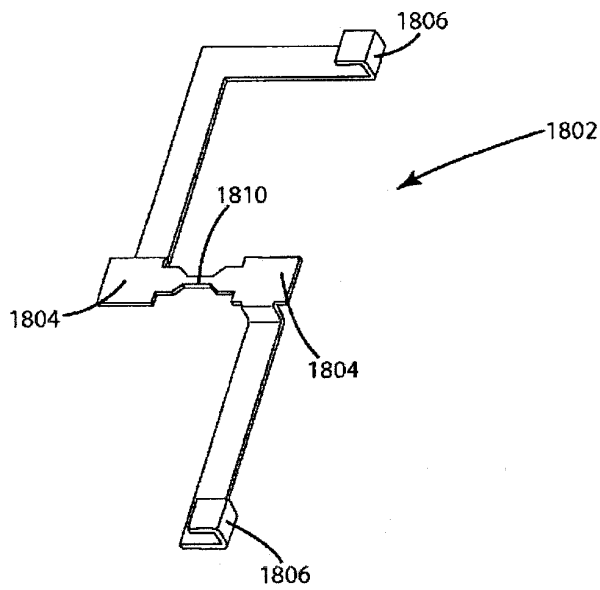


图 18B

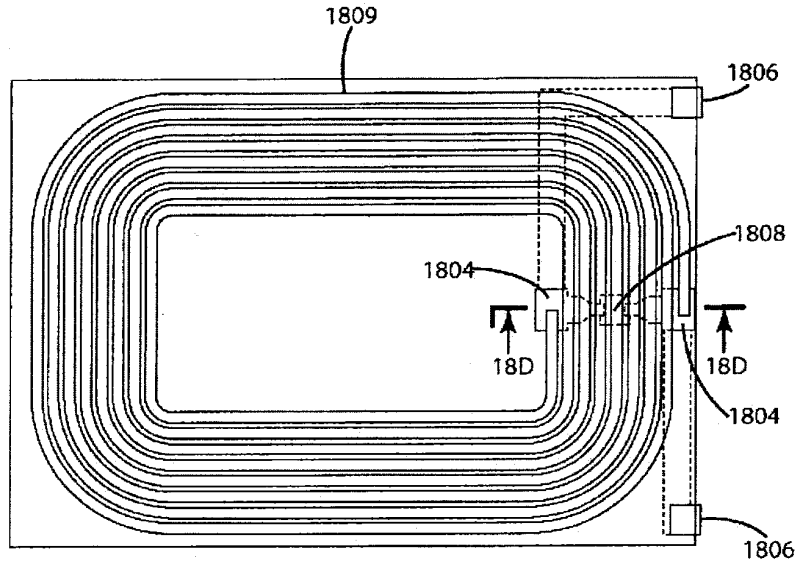


图 18C

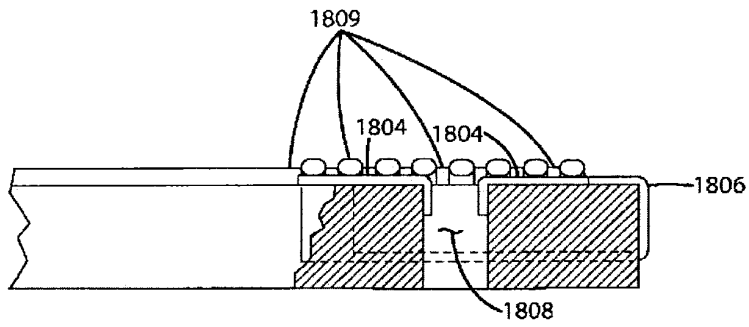


图 18D

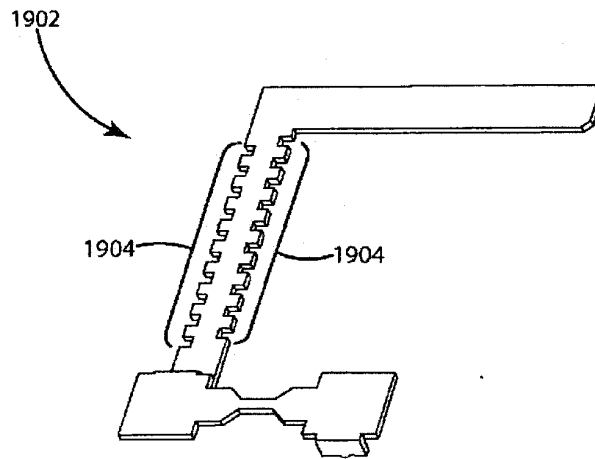


图 19

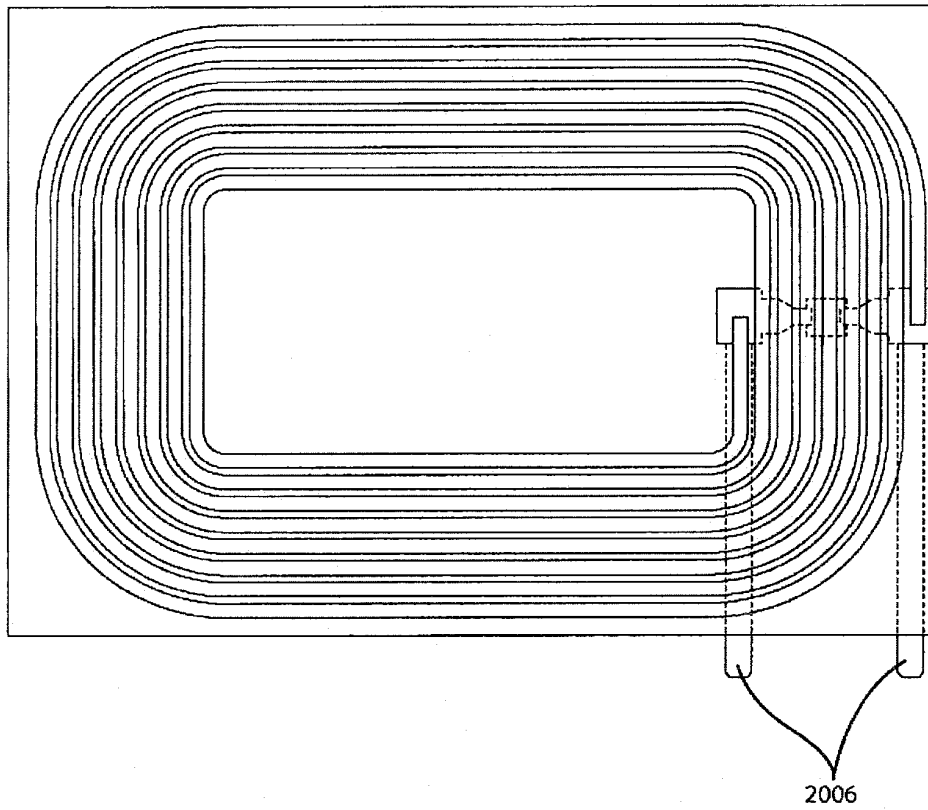


图 20

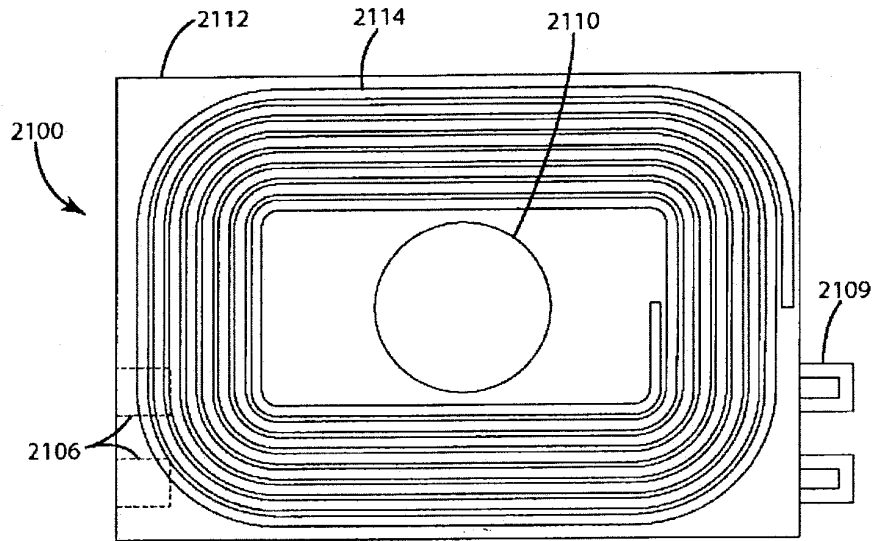


图 21

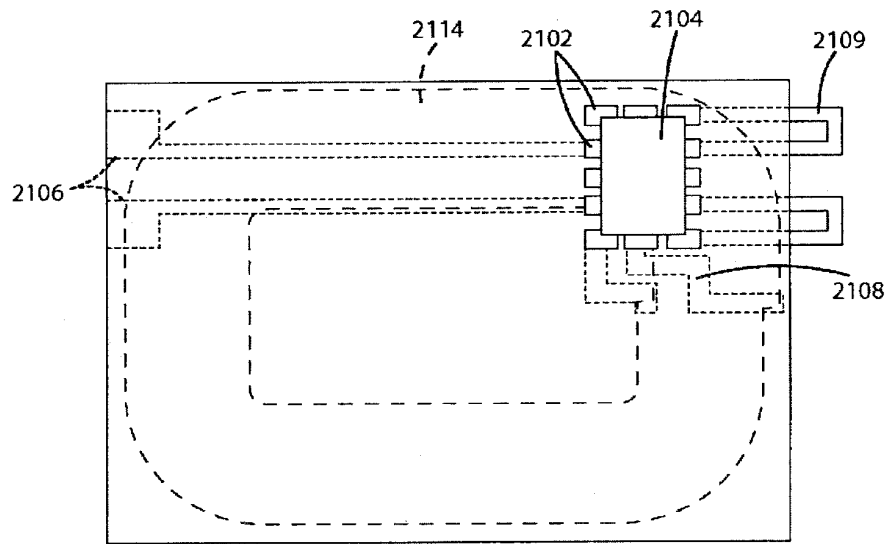


图 22

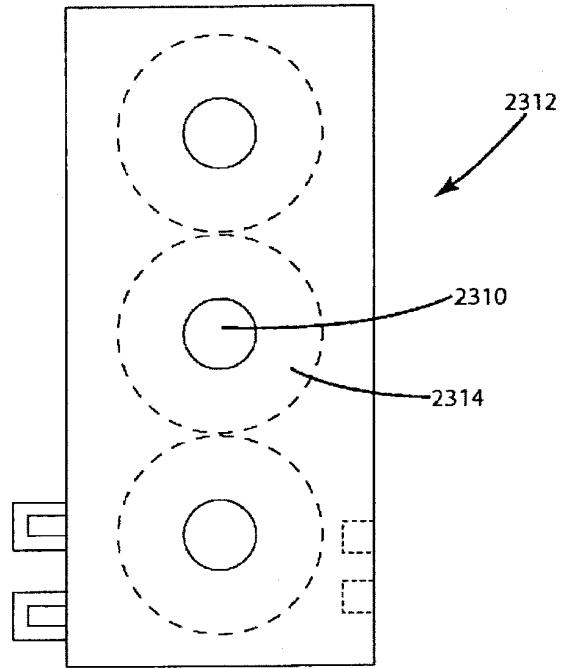


图 23

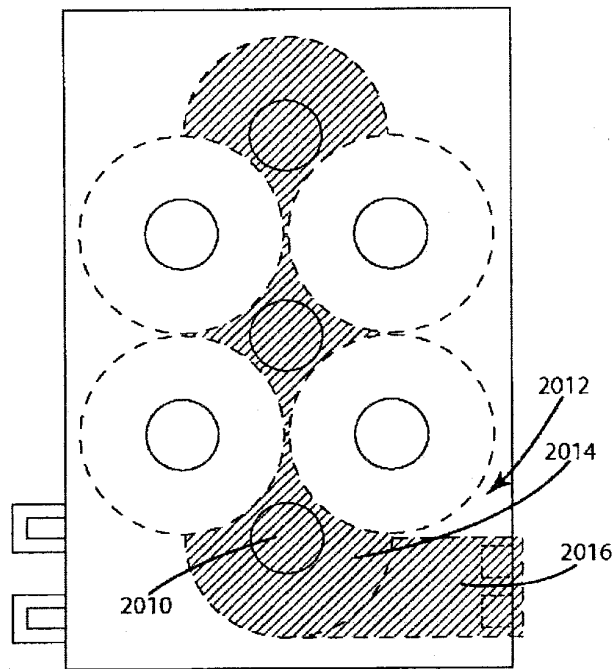


图 24

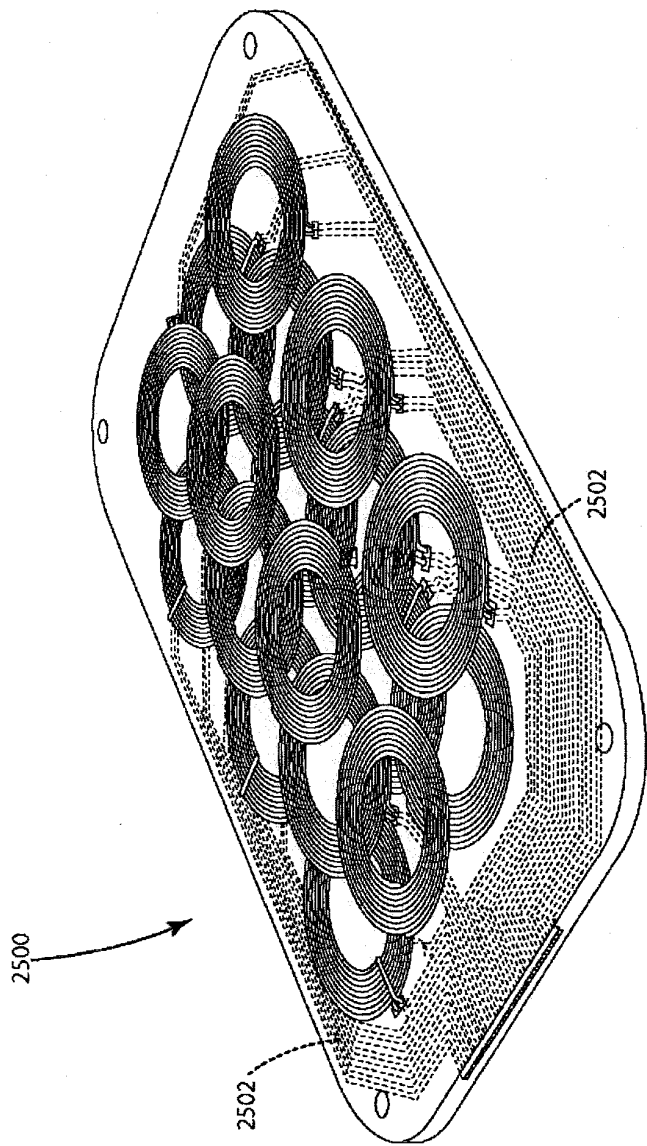


图 25

Electronic Acknowledgement Receipt

EFS ID:	31270530
Application Number:	14901426
International Application Number:	
Confirmation Number:	5436
Title of Invention:	RECEIVING ANTENNA AND WIRELESS POWER RECEIVING DEVICE INCLUDING THE SAME
First Named Inventor/Applicant Name:	Seok BAE
Customer Number:	34610
Filer:	Daniel Y.J. Kim/Sarah Garrett
Filer Authorized By:	Daniel Y.J. Kim
Attorney Docket Number:	DANA-0049
Receipt Date:	19-DEC-2017
Filing Date:	28-DEC-2015
Time Stamp:	12:44:54
Application Type:	U.S. National Stage under 35 USC 371

Payment information:

Submitted with Payment	no
------------------------	----

File Listing:

Document Number	Document Description	File Name	File Size(Bytes)/ Message Digest	Multi Part /.zip	Pages (if appl.)
1	Transmittal Letter	Transmittal.pdf	138761 0b7e1982d227122b6d52dd6214a10c6e4328dd9d	no	1

Warnings:

Information:					
2		Amendment.pdf	733525	yes	11
			1c1162fca87f46a0010f4982fa7173d71dc9a446		
Multipart Description/PDF files in .zip description					
		Document Description	Start	End	
		Amendment/Req. Reconsideration-After Non-Final Reject	1	1	
		Amendment Copy Claims/Response to Suggested Claims	2	8	
		Applicant Arguments/Remarks Made in an Amendment	9	11	
Warnings:					
Information:					
3	Transmittal Letter	IDS.pdf	278000	no	2
			1b1b167f2b75bfc0706e6129b6d55a3206f8b8af		
Warnings:					
Information:					
4	Information Disclosure Statement (IDS) Form (SB08)	1449.pdf	466643	no	1
			1ae12af537d515fc22d34b06ff9b10df6d074313		
Warnings:					
Information:					
This is not an USPTO supplied IDS fillable form					
5	Foreign Reference	TW200723596.pdf	2871593	no	149
			a597a4f2a40fd9857273641a2f2577436c3469d2		
Warnings:					
Information:					
6	Foreign Reference	EP2096711A1.pdf	946188	no	89
			56eec3e37a6edc2e64f6203ae36889dbf132123		
Warnings:					
Information:					

7	Foreign Reference	992A.pdf	19166187	no	17
			cb4d8d25657569f633b65fd335c68d5845535819		
Warnings:					
Information:					
8	Foreign Reference	168.pdf	4344224	no	36
			5155a449d0d82b302a3b526f59ffd2ca4a5d3a8f		
Warnings:					
Information:					
9	Non Patent Literature	CNOA.pdf	2815716	no	21
			f6245ec6562ff78c8ccc9b7b74afac4e942bc9		
Warnings:					
Information:					
Total Files Size (in bytes):				31760837	
<p>This Acknowledgement Receipt evidences receipt on the noted date by the USPTO of the indicated documents, characterized by the applicant, and including page counts, where applicable. It serves as evidence of receipt similar to a Post Card, as described in MPEP 503.</p> <p><u>New Applications Under 35 U.S.C. 111</u> If a new application is being filed and the application includes the necessary components for a filing date (see 37 CFR 1.53(b)-(d) and MPEP 506), a Filing Receipt (37 CFR 1.54) will be issued in due course and the date shown on this Acknowledgement Receipt will establish the filing date of the application.</p> <p><u>National Stage of an International Application under 35 U.S.C. 371</u> If a timely submission to enter the national stage of an international application is compliant with the conditions of 35 U.S.C. 371 and other applicable requirements a Form PCT/DO/EO/903 indicating acceptance of the application as a national stage submission under 35 U.S.C. 371 will be issued in addition to the Filing Receipt, in due course.</p> <p><u>New International Application Filed with the USPTO as a Receiving Office</u> If a new international application is being filed and the international application includes the necessary components for an international filing date (see PCT Article 11 and MPEP 1810), a Notification of the International Application Number and of the International Filing Date (Form PCT/RO/105) will be issued in due course, subject to prescriptions concerning national security, and the date shown on this Acknowledgement Receipt will establish the international filing date of the application.</p>					

Docket No.: DANA-0049

PATENT

IN THE UNITED STATES PATENT AND TRADEMARK OFFICE

In re Application of

Confirmation No.: 5436

Seok BAE; Donchul CHOI; and Soon Young HYUN

Group Art Unit: 2859

Serial No: 14/901,426

Examiner: M. Baye DIAO

Filed: December 28, 2015

Customer No.: 34610

For: RECEIVING ANTENNA AND WIRELESS POWER RECEIVING DEVICE INCLUDING THE SAME

U.S. Patent and Trademark Office
Customer Window, MAIL STOP AMENDMENT
Randolph Building
401 Dulany Street
Alexandria, Virginia 22314

Dear Sir:

Transmitted herewith is an Amendment and/or Reply in the above identified application.

- No additional fee is required.
- Also attached: Information Disclosure Statement (IDS)

The fee has been calculated as shown below:

	NO. OF CLAIMS	HIGHEST PREVIOUSLY PAID FOR	EXTRA CLAIMS	RATE	FEE
Total Claims	19	20	0	x \$80.00 =	\$0.00
Independent Claims	3	3	0	x \$420.00 =	\$0.00
If multiple claims newly presented, add \$780.00					\$0.00
Fee for extension of time					\$0.00
TOTAL FEE DUE					\$0.00

- Please charge my Deposit Account No. 16-0607 in the amount of \$ _____. An additional copy of this transmittal sheet is submitted herewith.
- Please charge my Credit Card. (Please see completed form PTO-2038 attached).
- The Commissioner is hereby authorized to charge payment of any fees associated with this communication or credit any overpayment, to Deposit Account No. 16-0607, including any filing fees under 37 C.F.R. §1.16 for presentation of extra claims and any patent application processing fees under 37 C.F.R. §1.17.

Respectfully submitted,
KED & ASSOCIATES, LLP



Paul H Kang
Registration No. 66,545

Correspondence Address:
P.O. Box 8638
Reston, VA 20195
(703) 766-3777 PHK/seg

Please direct all correspondence to Customer Number 34610

Q:\Documents\2414-049\700653

Under the Paperwork Reduction Act of 1995, no persons are required to respond to a collection of information unless it displays a valid OMB control number.

PATENT APPLICATION FEE DETERMINATION RECORD Substitute for Form PTO-875			Application or Docket Number 14/901,426	Filing Date 12/28/2015	<input type="checkbox"/> To be Mailed
ENTITY: <input checked="" type="checkbox"/> LARGE <input type="checkbox"/> SMALL <input type="checkbox"/> MICRO					
APPLICATION AS FILED – PART I					
(Column 1)		(Column 2)			
FOR	NUMBER FILED	NUMBER EXTRA	RATE (\$)	FEE (\$)	
<input type="checkbox"/> BASIC FEE <small>(37 CFR 1.16(a), (b), or (c))</small>	N/A	N/A	N/A		
<input type="checkbox"/> SEARCH FEE <small>(37 CFR 1.16(k), (i), or (m))</small>	N/A	N/A	N/A		
<input type="checkbox"/> EXAMINATION FEE <small>(37 CFR 1.16(o), (p), or (q))</small>	N/A	N/A	N/A		
TOTAL CLAIMS <small>(37 CFR 1.16(j))</small>	minus 20 =	*	X \$ =		
INDEPENDENT CLAIMS <small>(37 CFR 1.16(h))</small>	minus 3 =	*	X \$ =		
<input type="checkbox"/> APPLICATION SIZE FEE <small>(37 CFR 1.16(s))</small>	If the specification and drawings exceed 100 sheets of paper, the application size fee due is \$310 (\$155 for small entity) for each additional 50 sheets or fraction thereof. See 35 U.S.C. 41(a)(1)(G) and 37 CFR 1.16(s).				
<input type="checkbox"/> MULTIPLE DEPENDENT CLAIM PRESENT <small>(37 CFR 1.16(j))</small>					
* If the difference in column 1 is less than zero, enter "0" in column 2.			TOTAL		

APPLICATION AS AMENDED – PART II								
(Column 1)		(Column 2)		(Column 3)				
AMENDMENT	12/19/2017	CLAIMS REMAINING AFTER AMENDMENT		HIGHEST NUMBER PREVIOUSLY PAID FOR	PRESENT EXTRA	RATE (\$)	ADDITIONAL FEE (\$)	
	Total (37 CFR 1.16(i))	* 19	Minus	** 20	= 0	X \$80 =	0	
	Independent (37 CFR 1.16(h))	* 3	Minus	*** 3	= 0	X \$420 =	0	
	<input type="checkbox"/> Application Size Fee (37 CFR 1.16(s))							
	<input type="checkbox"/> FIRST PRESENTATION OF MULTIPLE DEPENDENT CLAIM (37 CFR 1.16(j))							
						TOTAL ADD'L FEE	0	

(Column 1)		(Column 2)		(Column 3)				
AMENDMENT		CLAIMS REMAINING AFTER AMENDMENT		HIGHEST NUMBER PREVIOUSLY PAID FOR	PRESENT EXTRA	RATE (\$)	ADDITIONAL FEE (\$)	
	Total (37 CFR 1.16(i))	*	Minus	**	=	X \$ =		
	Independent (37 CFR 1.16(h))	*	Minus	***	=	X \$ =		
	<input type="checkbox"/> Application Size Fee (37 CFR 1.16(s))							
	<input type="checkbox"/> FIRST PRESENTATION OF MULTIPLE DEPENDENT CLAIM (37 CFR 1.16(j))							
						TOTAL ADD'L FEE		
<p>* If the entry in column 1 is less than the entry in column 2, write "0" in column 3. ** If the "Highest Number Previously Paid For" IN THIS SPACE is less than 20, enter "20". *** If the "Highest Number Previously Paid For" IN THIS SPACE is less than 3, enter "3". The "Highest Number Previously Paid For" (Total or Independent) is the highest number found in the appropriate box in column 1.</p>						LIE STEPHEN W. HOOVER		

This collection of information is required by 37 CFR 1.16. The information is required to obtain or retain a benefit by the public which is to file (and by the USPTO to process) an application. Confidentiality is governed by 35 U.S.C. 122 and 37 CFR 1.14. This collection is estimated to take 12 minutes to complete, including gathering, preparing, and submitting the completed application form to the USPTO. Time will vary depending upon the individual case. Any comments on the amount of time you require to complete this form and/or suggestions for reducing this burden, should be sent to the Chief Information Officer, U.S. Patent and Trademark Office, U.S. Department of Commerce, P.O. Box 1450, Alexandria, VA 22313-1450. DO NOT SEND FEES OR COMPLETED FORMS TO THIS ADDRESS. **SEND TO: Commissioner for Patents, P.O. Box 1450, Alexandria, VA 22313-1450.**
 If you need assistance in completing the form, call 1-800-PTO-9199 and select option 2.



UNITED STATES PATENT AND TRADEMARK OFFICE

UNITED STATES DEPARTMENT OF COMMERCE
United States Patent and Trademark Office
Address: COMMISSIONER FOR PATENTS
P.O. Box 1450
Alexandria, Virginia 22313-1450
www.uspto.gov

Table with 5 columns: APPLICATION NO., FILING DATE, FIRST NAMED INVENTOR, ATTORNEY DOCKET NO., CONFIRMATION NO.
Row 1: 14/901,426, 12/28/2015, Seok BAE, DANA-0049, 5436
Row 2: 34610, 7590, 09/22/2017, KED & ASSOCIATES, LLP, P.O. Box 8638, Reston, VA 20195
Row 3: EXAMINER, DIAO, M BAYE
Row 4: ART UNIT, PAPER NUMBER, 2859
Row 5: NOTIFICATION DATE, DELIVERY MODE, 09/22/2017, ELECTRONIC

Please find below and/or attached an Office communication concerning this application or proceeding.

The time period for reply, if any, is set in the attached communication.

Notice of the Office communication was sent electronically on above-indicated "Notification Date" to the following e-mail address(es):

ked-docket@ked-iplaw.com
mydocket@icloud.com
keddocket@gmail.com

Office Action Summary	Application No. 14/901,426	Applicant(s) BAE ET AL.	
	Examiner M'BAYE DIAO	Art Unit 2859	AIA (First Inventor to File) Status Yes

-- The MAILING DATE of this communication appears on the cover sheet with the correspondence address --

Period for Reply

A SHORTENED STATUTORY PERIOD FOR REPLY IS SET TO EXPIRE 3 MONTHS FROM THE MAILING DATE OF THIS COMMUNICATION.

- Extensions of time may be available under the provisions of 37 CFR 1.136(a). In no event, however, may a reply be timely filed after SIX (6) MONTHS from the mailing date of this communication.
- If NO period for reply is specified above, the maximum statutory period will apply and will expire SIX (6) MONTHS from the mailing date of this communication.
- Failure to reply within the set or extended period for reply will, by statute, cause the application to become ABANDONED (35 U.S.C. § 133). Any reply received by the Office later than three months after the mailing date of this communication, even if timely filed, may reduce any earned patent term adjustment. See 37 CFR 1.704(b).

Status

- 1) Responsive to communication(s) filed on 12/28/2015.
 A declaration(s)/affidavit(s) under **37 CFR 1.130(b)** was/were filed on _____.
- 2a) This action is **FINAL**. 2b) This action is non-final.
- 3) An election was made by the applicant in response to a restriction requirement set forth during the interview on _____; the restriction requirement and election have been incorporated into this action.
- 4) Since this application is in condition for allowance except for formal matters, prosecution as to the merits is closed in accordance with the practice under *Ex parte Quayle*, 1935 C.D. 11, 453 O.G. 213.

Disposition of Claims*

- 5) Claim(s) 1-10 and 13-22 is/are pending in the application.
5a) Of the above claim(s) _____ is/are withdrawn from consideration.
- 6) Claim(s) 9,10 and 17-19 is/are allowed.
- 7) Claim(s) 1,3-4,7,8,13-16,21 and 22 is/are rejected.
- 8) Claim(s) 2,5,6 and 20 is/are objected to.
- 9) Claim(s) _____ are subject to restriction and/or election requirement.

* If any claims have been determined allowable, you may be eligible to benefit from the **Patent Prosecution Highway** program at a participating intellectual property office for the corresponding application. For more information, please see http://www.uspto.gov/patents/init_events/pph/index.jsp or send an inquiry to PPHfeedback@uspto.gov.

Application Papers

- 10) The specification is objected to by the Examiner.
- 11) The drawing(s) filed on 12/28/2015 is/are: a) accepted or b) objected to by the Examiner.
Applicant may not request that any objection to the drawing(s) be held in abeyance. See 37 CFR 1.85(a).
Replacement drawing sheet(s) including the correction is required if the drawing(s) is objected to. See 37 CFR 1.121(d).

Priority under 35 U.S.C. § 119

- 12) Acknowledgment is made of a claim for foreign priority under 35 U.S.C. § 119(a)-(d) or (f).

Certified copies:

- a) All b) Some** c) None of the:
1. Certified copies of the priority documents have been received.
2. Certified copies of the priority documents have been received in Application No. _____.
3. Copies of the certified copies of the priority documents have been received in this National Stage application from the International Bureau (PCT Rule 17.2(a)).

** See the attached detailed Office action for a list of the certified copies not received.

Attachment(s)

- 1) Notice of References Cited (PTO-892)
- 2) Information Disclosure Statement(s) (PTO/SB/08a and/or PTO/SB/08b)
Paper No(s)/Mail Date 12/28/2015:09/30/2016.
- 3) Interview Summary (PTO-413)
Paper No(s)/Mail Date. _____.
- 4) Other: _____.

DETAILED ACTION

Notice of Pre-AIA or AIA Status

1. The present application, filed on or after March 16, 2013, is being examined under the first inventor to file provisions of the AIA.

Response to Amendment

2. Acknowledgement is made of preliminary amendment filed on 12/28/2015 in which claims 1-4,9-10, and 13 are currently amended, claims 11-12 have been canceled while claims 14-22 have been newly added. By this amendment, claims 1-10,13-22 are now pending in the application for examination in a first action on the merits.

Priority

3. Receipt is acknowledged of certified copies of papers required by 37 CFR 1.55.

Information Disclosure Statement

4. The information disclosure statements (IDS) submitted on 12/28/2015 and 09/30/2016 are in compliance with the provisions of 37 CFR 1.97. Accordingly, the information disclosure statement are being considered by the examiner.

Claim Objections

5. Claim 3 is objected to because of the following informalities: Claim 3 recites, "The receiving antenna of claim 1, wherein the insulating layer includes is a film including a polyethylene terephthalate (PET) material". There is insufficient antecedent basis for this underlined limitations in the claims.

6. Appropriate correction is required.

Claim Rejections - 35 USC § 112

7. The following is a quotation of 35 U.S.C. 112(b):
(b) CONCLUSION.—The specification shall conclude with one or more claims particularly pointing out and distinctly claiming the subject matter which the inventor or a joint inventor regards as the invention.

The following is a quotation of 35 U.S.C. 112 (pre-AIA), second paragraph:
The specification shall conclude with one or more claims particularly pointing out and distinctly claiming the subject matter which the applicant regards as his invention.

8. Claim 3 is rejected under 35 U.S.C. 112(b) or 35 U.S.C. 112 (pre-AIA), second paragraph, as being indefinite for failing to particularly point out and distinctly claim the subject matter which the inventor or a joint inventor, or for pre-AIA the applicant regards as the invention.

Claim Rejections - 35 USC § 102

9. In the event the determination of the status of the application as subject to AIA 35 U.S.C. 102 and 103 (or as subject to pre-AIA 35 U.S.C. 102 and 103) is incorrect, any correction of the statutory basis for the rejection will not be considered a new ground of rejection if the prior art relied upon, and the rationale supporting the rejection, would be the same under either status.

10. The following is a quotation of the appropriate paragraphs of 35 U.S.C. 102 that form the basis for the rejections under this section made in this Office action:

A person shall be entitled to a patent unless –

(a)(1) the claimed invention was patented, described in a printed publication, or in public use, on sale or otherwise available to the public before the effective filing date of the claimed invention.

(a)(2) the claimed invention was described in a patent issued under section 151, or in an application for patent published or deemed published under section 122(b), in which the patent or application, as the case may be, names another inventor and was effectively filed before the effective filing date of the claimed invention.

11. Claims 1,7-8, and 13 are rejected under 35 U.S.C. 102(a)(1)|(a)(2) as being anticipated by Waffenschmidt et al., (Waffenschmidt) US 2013/0069444.

12. Regarding claim 1, Waffenschmidt discloses and shows in Fig. 20: A receiving antenna of a wireless power receiving device wirelessly charging electric power, the receiving antenna comprising: a substrate(212); a soft magnetic layer (202)stacked on the substrate(212); a receiving coil (203) wound in parallel with a plane of the soft magnetic layer(202), and formed inside of the soft magnetic layer; and an adhesive layer (211) formed between the soft magnetic layer(202) and the receiving coil(203)([0087]-[0088]).

13. Regarding claim 13, Waffenschmidt discloses([0087]-[0088]) and shows in Fig. 20: A wireless power receiving device wirelessly charging electric power, comprising: a substrate(212); a soft magnetic layer (202)stacked on the substrate; a receiving coil (203) wound in parallel with a plane of the soft magnetic layer(202), and formed inside of the soft magnetic layer(202); an adhesive layer (211) formed between the soft magnetic layer (202) and the receiving coil(203); a circuit unit (i.e. **additional power converters and On top of the carrier electronic components may be located, e.g. to rectify the alternating voltage of the receiver**) connected to the receiving coil(203), and configured to convert electromagnetic energy into electrical energy; and a storage unit configured to store the electrical energy(see [0087],[0094]).

14. Regarding claim 7, Waffenschmidt disclose, wherein the receiving antenna further comprising a support means (213)stacked on the receiving coil(203)([0087]).

15. Regarding claim 8, Waffenschmidt disclose, wherein the receiving coil **(203)** is embedded in one surface of the soft magnetic layer **(202)**(see **Fig. 20**).

Claim Rejections - 35 USC § 103

16. In the event the determination of the status of the application as subject to AIA 35 U.S.C. 102 and 103 (or as subject to pre-AIA 35 U.S.C. 102 and 103) is incorrect, any correction of the statutory basis for the rejection will not be considered a new ground of rejection if the prior art relied upon, and the rationale supporting the rejection, would be the same under either status.

17. The following is a quotation of 35 U.S.C. 103 which forms the basis for all obviousness rejections set forth in this Office action:

A patent for a claimed invention may not be obtained, notwithstanding that the claimed invention is not identically disclosed as set forth in section 102, if the differences between the claimed invention and the prior art are such that the claimed invention as a whole would have been obvious before the effective filing date of the claimed invention to a person having ordinary skill in the art to which the claimed invention pertains. Patentability shall not be negated by the manner in which the invention was made.

18. The factual inquiries set forth in *Graham v. John Deere Co.*, 383 U.S. 1, 148 USPQ 459 (1966), that are applied for establishing a background for determining obviousness under 35 U.S.C. 103 are summarized as follows:

1. Determining the scope and contents of the prior art.
2. Ascertaining the differences between the prior art and the claims at issue.
3. Resolving the level of ordinary skill in the pertinent art.
4. Considering objective evidence present in the application indicating

obviousness or nonobviousness.

19. This application currently names joint inventors. In considering patentability of the claims the examiner presumes that the subject matter of the various claims was

commonly owned as of the effective filing date of the claimed invention(s) absent any evidence to the contrary. Applicant is advised of the obligation under 37 CFR 1.56 to point out the inventor and effective filing dates of each claim that was not commonly owned as of the effective filing date of the later invention in order for the examiner to consider the applicability of 35 U.S.C. 102(b)(2)(C) for any potential 35 U.S.C. 102(a)(2) prior art against the later invention.

20. **Claims 3-4,14,15,16,21, and 22 are rejected under 35 U.S.C. 103 as being unpatentable over Waffenschmidt et al., (Waffenschmidt) US 2013/0069444. In view of Official Notice or Inoue US 2009/0121677(cited by Applicants)..**

21. Regarding claims 4,15,16,21, and 22, Waffenschmidt discloses wherein the soft magnetic layer **(202)** includes a plurality of stacked sheets **(210)** including and a polymer resin(**Ferrite polymer compound,[0088]**).

22. Waffenschmidt discloses all the claimed limitations except for the soft magnetic layer including a soft magnetic metal powder. It would have been obvious to one having ordinary skill in the art at the time of the effective filing date of the claimed invention to include in the soft magnetic layer of the device of Waffenschmidt to include a soft magnetic metal powder and a polymer resin, since it has been held to be within the general skill of a worker in the art to select a known material on the basis of its suitability for the intended use as a matter of obvious design choice. In re Leshin, 125 USPQ 416.

23. Inoue also teaches factual evidence of a power receiving portion including making the power receiving portion thinner corresponding to thickness reduction of an

apparatus by using a flat coil formed by printing a metal powder paste in a spiral shape on a substrate([0005],[0006],[0039]).

24. Therefore it would have been obvious to one having ordinary skill in the art at the time of the effective filing date of the claimed invention to include in the soft magnetic layer of the device of Waffenschmidt to include a soft magnetic metal powder and a polymer resin, as did Inoue, for the advantages of making the power receiving portion thinner, as per the teachings of Inoue([0006]).

25. **Regarding claim 3**, Waffenschmidt discloses all the claimed limitations except for wherein the insulating layer includes is a film including a polyethylene terephthalate (PET) material.. It would have been obvious to one having ordinary skill in the art at the time of the effective filing date of the claimed invention to have included in the insulating layer of Waffenschmidt, a film including a polyethylene terephthalate (PET) material, since it has been held to be within the general skill of a worker in the art to select a known material on the basis of its suitability for the intended use as a matter of obvious design choice. In re Leshin, 125 USPQ 416.

26. Accordingly claim 3 would have been obvious.

27. Accordingly claims 4,14,15,16,21, and 22 would have been obvious.

Allowable Subject Matter

28. Claims 2,5-6,,20,are objected to as being dependent upon a rejected base claim, but would be allowable if rewritten in independent form including all of the limitations of the base claim and any intervening claims.

29. Claims 9-10,17-19 are allowed over the prior art of record.

30. Regarding claim 9, the prior art of record either taken alone or in combination thereof fail to teach or reasonably suggest, in the claimed combination, a method of fabricating a receiving antenna comprising among other patentable steps, "...stacking a plurality of sheets including a soft magnetic metal powder and a polymer resin; forming an adhesive layer on an upper plane of the plurality of sheets; disposing a receiving coil on the adhesive layer; and compressing the plurality of sheets, the adhesive layer, and the receiving coil to form the receiving coil inside of the plurality of sheets".

31. Claim 10,17-19 depend either directly or indirectly from claim 9 and therefore are also allowed for the same reasons.

32. Regarding claim 5, the prior art of record does not teach or reasonably suggest, In the claimed combination, "wherein the soft magnetic layer includes a groove portion".

33. Regarding claims 2 and 20, patentability exists at least in part, "wherein the adhesive layer includes a first adhesive layer formed on the soft magnetic layer, an insulating layer formed on the first adhesive layer, and a second adhesive layer formed on the insulating layer".

34. Claim 6 depend directly from claim 5 and thus is also allowable for the same reason.

Citation of Prior Art

35. For a list of related prior art references not mentioned above but disclose related apparatus or method, see Form PTO-892.

Conclusion

Any inquiry concerning this communication or earlier communications from the examiner should be directed to M'BAYE DIAO whose telephone number is (571)272-6127. The examiner can normally be reached on 8:30-7:00; Friday off.

Examiner interviews are available via telephone, in-person, and video conferencing using a USPTO supplied web-based collaboration tool. To schedule an interview, applicant is encouraged to use the USPTO Automated Interview Request (AIR) at <http://www.uspto.gov/interviewpractice>.

If attempts to reach the examiner by telephone are unsuccessful, the examiner's supervisor, DREW DUNN can be reached on 571-272-2312. The fax phone number for the organization where this application or proceeding is assigned is 571-273-8300.

Information regarding the status of an application may be obtained from the Patent Application Information Retrieval (PAIR) system. Status information for published applications may be obtained from either Private PAIR or Public PAIR. Status information for unpublished applications is available through Private PAIR only. For more information about the PAIR system, see <http://pair-direct.uspto.gov>. Should you have questions on access to the Private PAIR system, contact the Electronic Business Center (EBC) at 866-217-9197 (toll-free). If you would like assistance from a USPTO Customer Service Representative or access to the automated information system, call 800-786-9199 (IN USA OR CANADA) or 571-272-1000.

M'baye Diao
Primary Examiner
Art Unit 2859

Application/Control Number: 14/901,426
Art Unit: 2859

Page 10

/M'BAYE DIAO/
Primary Examiner, Art Unit 2859
September 17, 2017

Notice of References Cited	Application/Control No. 14/901,426	Applicant(s)/Patent Under Reexamination BAE ET AL.	
	Examiner M'BAYE DIAO	Art Unit 2859	Page 1 of 1

U.S. PATENT DOCUMENTS

*		Document Number Country Code-Number-Kind Code	Date MM-YYYY	Name	CPC Classification	US Classification
*	A	US-5,940,362 A	08-1999	Plonsky; Christopher B.	G08B13/2408	369/273
*	B	US-2005/0226136 A1	10-2005	Moribe, Mineo	G11B11/10591	369/275.4
*	C	US-2013/0169399 A1	07-2013	YOO; Young Seuck	H01F17/0013	336/180
*	D	US-9,362,776 B2	06-2016	Low; Zhen Ning	G04C10/00	1/1
*	E	US-9,504,194 B2	11-2016	Lee; Dong Hoon	H01F38/14	1/1
*	F	US-2013/0069444 A1	03-2013	Waffenschmidt; Eberhard	H01F38/14	307/104
	G	US-				
	H	US-				
	I	US-				
	J	US-				
	K	US-				
	L	US-				
	M	US-				

FOREIGN PATENT DOCUMENTS

*		Document Number Country Code-Number-Kind Code	Date MM-YYYY	Country	Name	CPC Classification
	N					
	O					
	P					
	Q					
	R					
	S					
	T					

NON-PATENT DOCUMENTS

*		Include as applicable: Author, Title Date, Publisher, Edition or Volume, Pertinent Pages)
	U	
	V	
	W	
	X	

*A copy of this reference is not being furnished with this Office action. (See MPEP § 707.05(a).)
Dates in MM-YYYY format are publication dates. Classifications may be US or foreign.

EAST Search History

EAST Search History (Prior Art)

Ref #	Hits	Search Query	DBs	Default Operator	Plurals	Time Stamp
L1	1	(soft near magnetic near layer) with (groove near section)	US-PGPUB; USPAT; EPO	OR	ON	2017/09/17 15:15
L2	3	(soft near magnetic near layer) same (groove near section)	US-PGPUB; USPAT; EPO	OR	ON	2017/09/17 15:22
L3	4	("20090121677" "20100007215" "20100052992" "20110050382").PN.	US-PGPUB; USPAT	OR	ON	2017/09/17 15:26
S1	1	"20160156215"	US-PGPUB; USPAT; EPO	OR	ON	2017/09/17 08:24
S2	1	"20160156103"	US-PGPUB; USPAT; EPO	OR	ON	2017/09/17 08:25
S3	2	"9504194".pn.	US-PGPUB; USPAT; EPO	OR	ON	2017/09/17 09:14
S4	1	"9252611".pn.	US-PGPUB; USPAT; EPO	OR	ON	2017/09/17 09:56
S5	1	"20130249302"	US-PGPUB; USPAT; EPO	OR	ON	2017/09/17 10:03
S6	11	recv\$3 near (antenna choke coil)	US-PGPUB; USPAT; EPO	OR	ON	2017/09/17 10:31
S7	2522191	substrate	US-PGPUB; USPAT; EPO	OR	ON	2017/09/17 10:31
S8	7113	soft near magnetic near layer	US-PGPUB; USPAT; EPO	OR	ON	2017/09/17 10:31
S9	40087	receiv\$3 near coil	US-PGPUB; USPAT; EPO	OR	ON	2017/09/17 10:32
S10	234770	adhesive near layer	US-	OR	ON	2017/09/17

			PGPUB; USPAT; EPO			10:32
S11	40317	receiv\$3 near (coil choke)	US- PGPUB; USPAT; EPO	OR	ON	2017/09/17 10:32
S12	245187	receiv\$3 near (antenna choke coil)	US- PGPUB; USPAT; EPO	OR	ON	2017/09/17 10:33
S13	1	S12 with (S7 same S8 same S9 same S10)	US- PGPUB; USPAT; EPO	OR	ON	2017/09/17 10:34
S14	1	S12 and (S7 same S8 same S9 same S10)	US- PGPUB; USPAT; EPO	OR	ON	2017/09/17 10:34
S15	7	S12 and (S7 and S8 and S9 and S10)	US- PGPUB; USPAT; EPO	OR	ON	2017/09/17 10:34
S16	2	"20130169399"	US- PGPUB; USPAT; EPO	OR	ON	2017/09/17 10:41
S17	1	"9362776".pn.	US- PGPUB; USPAT; EPO	OR	ON	2017/09/17 10:59
S18	581	S10 S11 S12	US- PGPUB; USPAT; EPO	AND	ON	2017/09/17 11:21
S19	5781	S7 S8	US- PGPUB; USPAT; EPO	AND	ON	2017/09/17 11:21
S20	7	S18 and S19	US- PGPUB; USPAT; EPO	AND	ON	2017/09/17 11:21
S21	148	(US-4631766-\$ or US-5358110-\$ or US-5382223-\$ or US-5399051-\$ or US-6081948-\$ or US-4276884-\$ or US-4278456-\$ or US-4286696-\$ or US-4300865-\$ or US-4317733-\$ or US-4319616-\$ or US-4350375-\$ or US-4361090-\$ or US-4381830-\$ or US-4392012-\$ or US-4396799-\$ or US-4411460-\$ or US-4440706-\$ or US-4444795-\$ or US-4480513-\$ or US-4491018-\$ or US-4501034-\$ or US-4522603-\$ or US-4536165-\$ or US-4555806-\$ or US-4587582-\$).did. or (US-4590542-\$ or US-4590340-\$ or US-4610676-\$ or US-4761032-\$ or US-4791751-\$ or US-4869014-\$ or US-4911153-\$ or US-4924121-\$ or US-	USPAT	OR	ON	2017/09/17 11:23

		4933258-\$ or US-4938396-\$ or US-4974771-\$ or US-5178107-\$ or US-5202176-\$ or US-5226674-\$ or US-5230178-\$ or US-5243799-\$ or US-5244277-\$ or US-5289979-\$ or US-5292265-\$ or US-5344086-\$ or US-5360112-\$ or US-5369079-\$ or US-5370486-\$ or US-5374129-\$ or US-5405095-\$ or US-5415573-\$ or US-5417668-\$.did. or (US-5437364-\$ or US-5443214-\$ or US-5452794-\$ or US-5477519-\$ or US-5505477-\$ or US-5536985-\$ or US-5535462-\$ or US-5542753-\$ or US-5562215-\$ or US-5591207-\$ or US-5604752-\$ or US-5621764-\$ or US-5660410-\$ or US-5669493-\$ or US-5690350-\$ or US-5711581-\$ or US-5717872-\$ or US-5727029-\$ or US-5728170-\$ or US-5766174-\$ or US-5769086-\$ or US-5791690-\$ or US-5806876-\$ or US-5845512-\$ or US-5845406-\$ or US-5853188-\$ or US-5872835-\$.did. or (US-5894669-\$ or US-5899160-\$ or US-5906058-\$ or US-5915720-\$ or US-6002716-\$ or US-6035040-\$ or US-6044106-\$ or US-6044111-\$ or US-6099530-\$ or US-6109583-\$ or US-6115435-\$ or US-6134188-\$ or US-6138437-\$ or US-6168183-\$ or US-6192618-\$ or US-6193515-\$ or US-6209771-\$ or US-6221019-\$ or US-6244808-\$ or US-3617078-\$ or US-3642312-\$ or US-3915833-\$ or US-3804184-\$ or US-4024945-\$ or US-4043445-\$ or US-4062569-\$ or US-4160230-\$.did. or (US-4166507-\$ or US-4179829-\$ or US-4068581-\$ or US-4106868-\$ or US-4109556-\$ or US-4129059-\$ or US-4242853-\$ or US-4243122-\$ or US-4243851-\$ or US-4245158-\$ or US-4244459-\$ or US-4244360-\$ or US-4244123-\$ or US-4245360-\$ or US-4245960-\$ or US-4245456-\$ or US-4246738-\$ or US-4248228-\$ or US-4249432-\$ or US-4251066-\$ or US-4252324-\$ or US-4252135-\$ or US-4254206-\$ or US-4254908-\$ or US-4256109-\$ or US-4256952-\$ or US-4259160-\$.did. or (US-4261054-\$ or US-4261366-\$ or US-4262909-\$ or US-4264549-\$ or US-4265167-\$ or US-4267794-\$ or US-4268991-\$ or US-4270070-\$ or US-4270720-\$ or US-4270719-\$ or US-4270426-\$ or US-4275535-\$ or US-4278236-\$ or US-4278029-\$.did.				
S22	0	S18 and S21	US-PGPUB; USPAT; EPO	OR	ON	2017/09/17 11:23
S23	13392	(320/108;307/104;455/41.1,572,573).ccls.	US-PGPUB; USPAT;	OR	ON	2017/09/17 11:24

EAST Search History


			EPO			
S24	40	S18 and S23	US-PGPUB; USPAT; EPO	OR	ON	2017/09/17 11:24
S25	11955	(H04B5/0037 H02J7/025 H02J5/005).cpc.	US-PGPUB; USPAT; EPO	OR	ON	2017/09/17 11:28
S26	105	S18 and S25	US-PGPUB; USPAT; EPO	OR	ON	2017/09/17 11:28
S27	1	(S24 S26) and ((adhesive near layer) near formed near between near5 (soft near magnetic near layer))	US-PGPUB; USPAT; EPO	OR	ON	2017/09/17 11:30
S28	2	(S24 S26) and ((adhesive near layer) with formed same between near5 (soft near magnetic near layer))	US-PGPUB; USPAT; EPO	OR	ON	2017/09/17 11:31
S29	6	(S24 S26) and S8 and S10 and S12	US-PGPUB; USPAT; EPO	OR	ON	2017/09/17 11:34

EAST Search History (Interference)

< This search history is empty >

9/ 17/ 2017 5:12:17 PM

C:\Users\mdiao\Documents\EAST\Workspaces\mbaye_01426.wsp

<i>Index of Claims</i> 	Application/Control No. 14901426	Applicant(s)/Patent Under Reexamination BAE ET AL.
	Examiner M'BAYE DIAO	Art Unit 2859

✓	Rejected
=	Allowed


-	Cancelled
÷	Restricted

N	Non-Elected
I	Interference

A	Appeal
O	Objected

Claims renumbered in the same order as presented by applicant
 CPA
 T.D.
 R.1.47

CLAIM		DATE							
Final	Original	09/17/2017							
	1	✓							
	2	○							
	3	✓							
	4	✓							
	5	○							
	6	○							
	7	✓							
	8	✓							
	9	=							
	10	=							
	11	-							
	12	-							
	13	✓							
	14	✓							
	15	✓							
	16	✓							
	17	=							
	18	=							
	19	=							
	20	○							
	21	✓							
	22	✓							

Search Notes 	Application/Control No. 14901426	Applicant(s)/Patent Under Reexamination BAE ET AL.
	Examiner M'BAYE DIAO	Art Unit 2859

CPC- SEARCHED		
Symbol	Date	Examiner
H01Q 7/06	09/17/2017	MD
H02J50/20,27; H02J7/025	09/17/2017	MD

CPC COMBINATION SETS - SEARCHED		
Symbol	Date	Examiner

US CLASSIFICATION SEARCHED			
Class	Subclass	Date	Examiner
320	108	09/17/2017	MD
307	104	09/17/2017	MD

* See search history printout included with this form or the SEARCH NOTES box below to determine the scope of the search.

SEARCH NOTES		
Search Notes	Date	Examiner
EAST(Search Notes Attached).	09/17/2017	MD
Inventor Name and Assignee search (EAST).	09/16/2017	MD
PLUS Search Conducted.	08/22/2017	MD

INTERFERENCE SEARCH			
US Class/ CPC Symbol	US Subclass / CPC Group	Date	Examiner

	M'BAYE DIAO/ Primary Examiner.Art Unit 2859
--	------------------------------------------------



UNITED STATES PATENT AND TRADEMARK OFFICE

UNITED STATES DEPARTMENT OF COMMERCE
 United States Patent and Trademark Office
 Address: COMMISSIONER FOR PATENTS
 P.O. Box 1450
 Alexandria, Virginia 22313-1450
 www.uspto.gov

BIB DATA SHEET

CONFIRMATION NO. 5436

SERIAL NUMBER	FILING or 371(c) DATE RULE	CLASS	GROUP ART UNIT	ATTORNEY DOCKET NO. DANA-0049		
14/901,426	12/28/2015	320	2859			
APPLICANTS LG INNOTEK CO., LTD., Seoul, KOREA, REPUBLIC OF;						
INVENTORS Seok BAE, Seoul, KOREA, REPUBLIC OF; Donchul CHOI, Seoul, KOREA, REPUBLIC OF; Soon Young Hyun, Seoul, KOREA, REPUBLIC OF;						
** CONTINUING DATA ***** This application is a 371 of PCT/KR2014/005258 06/16/2014						
** FOREIGN APPLICATIONS ***** REPUBLIC OF KOREA 10-2013-0074620 06/27/2013						
** IF REQUIRED, FOREIGN FILING LICENSE GRANTED ** 02/23/2016						
Foreign Priority claimed <input checked="" type="checkbox"/> Yes <input type="checkbox"/> No 35 USC 119(a-d) conditions met <input checked="" type="checkbox"/> Yes <input type="checkbox"/> No Verified and Acknowledged <u>/M'BAYE DIAO/</u> Examiner's Signature		<input type="checkbox"/> Met after Allowance Initials	STATE OR COUNTRY KOREA, REPUBLIC OF	SHEETS DRAWINGS 7	TOTAL CLAIMS 20	INDEPENDENT CLAIMS 3
ADDRESS KED & ASSOCIATES, LLP P.O. Box 8638 Reston, VA 20195 UNITED STATES						
TITLE RECEIVING ANTENNA AND WIRELESS POWER RECEIVING DEVICE INCLUDING THE SAME						
FILING FEE RECEIVED 1620	FEES: Authority has been given in Paper No. _____ to charge/credit DEPOSIT ACCOUNT No. _____ for following:		<input type="checkbox"/> All Fees <input type="checkbox"/> 1.16 Fees (Filing) <input type="checkbox"/> 1.17 Fees (Processing Ext. of time) <input type="checkbox"/> 1.18 Fees (Issue) <input type="checkbox"/> Other _____ <input type="checkbox"/> Credit			

PLUS Search Results for S/N 14901426, Searched Tue Aug 22 14:36:33 EDT 2017
 The Patent Linguistics Utility System (PLUS) is a USPTO automated search system for U.S. Patents from 1971 to the present PLUS is a query-by-example search system which produces a list of patents that are most closely related linguistically to the application searched. This search was prepared by the staff of the Scientific and Technical Information Center, SIRA.

4631766 99	5374129 95	6209771 95
5358110 96	5405095 95	6221019 95
5382223 96	5415573 95	6244808 95
5399051 96	5417668 95	3617078 93
6081948 96	5437364 95	3642312 93
4276884 95	5443214 95	3915833 93
4278456 95	5452794 95	3804184 93
4286696 95	5477519 95	4024945 93
4300865 95	5505477 95	4043445 93
4317733 95	5536985 95	4062569 93
4319616 95	5535462 95	4160230 93
4350375 95	5542753 95	4166507 93
4361090 95	5562215 95	4179829 93
4381830 95	5591207 95	4068581 93
4392012 95	5604752 95	4106868 93
4396799 95	5621764 95	4109556 93
4411460 95	5660410 95	4129059 93
4440706 95	5669493 95	4242853 93
4444795 95	5690350 95	4243122 93
4480513 95	5711581 95	4243851 93
4491018 95	5717872 95	4245158 93
4501034 95	5727029 95	4244459 93
4522603 95	5728170 95	4244360 93
4536165 95	5766174 95	4244123 93
4555806 95	5769086 95	4245360 93
4587582 95	5791690 95	4245960 93
4590542 95	5806876 95	4245456 93
4590340 95	5845512 95	4246738 93
4610676 95	5845406 95	4248228 93
4761032 95	5853188 95	4249432 93
4791751 95	5872835 95	4251066 93
4869014 95	5894669 95	4252324 93
4911153 95	5899160 95	4252135 93
4924121 95	5906058 95	4254206 93
4933258 95	5915720 95	4254908 93
4938396 95	6002716 95	4256109 93
4974771 95	6035040 95	4256952 93
5178107 95	6044106 95	4259160 93
5202176 95	6044111 95	4261054 93
5226674 95	6099530 95	4261366 93
5230178 95	6109583 95	4262909 93
5243799 95	6115435 95	4264549 93
5244277 95	6134188 95	4265167 93
5289979 95	6138437 95	4267794 93
5292265 95	6168183 95	4268991 93
5344086 95	6192618 95	4270070 93
5360112 95	6193515 95	4270720 93
5369079 95	6209771 95	4270719 93
5370486 95	6221019 95	4270426 93

4275535 93
4278236 93
4278029 93

Electronic Acknowledgement Receipt

EFS ID:	27095560
Application Number:	14901426
International Application Number:	
Confirmation Number:	5436
Title of Invention:	RECEIVING ANTENNA AND WIRELESS POWER RECEIVING DEVICE INCLUDING THE SAME
First Named Inventor/Applicant Name:	Seok BAE
Customer Number:	34610
Filer:	Daniel Y.J. Kim/Deborah Kimberlin
Filer Authorized By:	Daniel Y.J. Kim
Attorney Docket Number:	DANA-0049
Receipt Date:	30-SEP-2016
Filing Date:	28-DEC-2015
Time Stamp:	18:36:57
Application Type:	U.S. National Stage under 35 USC 371

Payment information:

Submitted with Payment	no
------------------------	----

File Listing:

Document Number	Document Description	File Name	File Size(Bytes)/ Message Digest	Multi Part /.zip	Pages (if appl.)
1	Transmittal Letter	IDS.pdf	149455 2dce5f729372374e567ada7e65cebe5a117d9ed1	no	2

Warnings:

Information:					
2	Information Disclosure Statement (IDS) Form (SB08)	1449.pdf	182769	no	1
			c6008e0bdca31cfe8e7b5d8b6f88b9217c862a61		
Warnings:					
Information:					
This is not an USPTO supplied IDS fillable form					
3	Other Reference-Patent/App/Search documents	20160712EPSR.pdf	354208	no	7
			ec39cca21933178224139df53e0447b3f1c1adc		
Warnings:					
Information:					
Total Files Size (in bytes):				686432	
<p>This Acknowledgement Receipt evidences receipt on the noted date by the USPTO of the indicated documents, characterized by the applicant, and including page counts, where applicable. It serves as evidence of receipt similar to a Post Card, as described in MPEP 503.</p> <p><u>New Applications Under 35 U.S.C. 111</u> If a new application is being filed and the application includes the necessary components for a filing date (see 37 CFR 1.53(b)-(d) and MPEP 506), a Filing Receipt (37 CFR 1.54) will be issued in due course and the date shown on this Acknowledgement Receipt will establish the filing date of the application.</p> <p><u>National Stage of an International Application under 35 U.S.C. 371</u> If a timely submission to enter the national stage of an international application is compliant with the conditions of 35 U.S.C. 371 and other applicable requirements a Form PCT/DO/EO/903 indicating acceptance of the application as a national stage submission under 35 U.S.C. 371 will be issued in addition to the Filing Receipt, in due course.</p> <p><u>New International Application Filed with the USPTO as a Receiving Office</u> If a new international application is being filed and the international application includes the necessary components for an international filing date (see PCT Article 11 and MPEP 1810), a Notification of the International Application Number and of the International Filing Date (Form PCT/RO/105) will be issued in due course, subject to prescriptions concerning national security, and the date shown on this Acknowledgement Receipt will establish the international filing date of the application.</p>					

Docket No.: **DANA-0049**

PATENT

IN THE UNITED STATES PATENT AND TRADEMARK OFFICE

In re Application of

Confirmation No.: **5436**

Seok BAE; Donchul CHOI; and Soon Young HYUN

Group Art Unit: **2859**

Serial No.: **14/901,426**

Examiner: **Drew A. DUNN**

Filed: **December 28, 2015**

Customer No.: **34610**

For: **RECEIVING ANTENNA AND WIRELESS POWER RECEIVING DEVICE
INCLUDING THE SAME**

INFORMATION DISCLOSURE STATEMENT

U.S. Patent and Trademark Office
Customer Service Window
Randolph Building
401 Dulany Street
Alexandria, Virginia 22314

Sir:

Pursuant to 37 C.F.R. §1.56, the attention of the Patent and Trademark Office is hereby directed to the references listed on the attached PTO-1449. One copy of each non-U.S. reference is attached. It is respectfully requested that the information be expressly considered during the prosecution of this application, and that the reference(s) be made of record therein and appear among the "References Cited" on any patent to issue therefrom.

Applicants have listed publication dates on the attached PTO-1449 based on information presently available to the undersigned. However, the listed publication dates should not be construed as an admission that the information was actually published on the indicated date. Applicants reserve the right to establish the patentability of the claimed invention over any of the information provided herewith, and/or to prove that this information may not be prior art, and/or to prove that this information may not be enabling for the teachings purportedly offered. This statement should not be construed as a representation that a search has been made, that information cited in the statement is considered to be and/or is material to patentability, or that information more material to the examination of the present patent application does not exist. The Examiner is specifically requested not to rely solely on the material submitted herewith. It is further understood that the Examiner will consider information that was cited or submitted to the U.S. Patent and Trademark Office in a prior application relied on under 35 U.S.C. §120. 1138 OG 37, 38 (May 19, 1992).

1. This Information Disclosure Statement is being filed (i) within three months of the U.S. filing date of a U.S. application other than a CPA continued prosecution application under §1.53(d) OR (ii) within three months of the date of entry of the national stage as set forth in §1.491 in an international application OR (iii) before the mailing date of a first Office Action on the merits OR (iv) before the mailing of a first Office Action after the filing of a Request for continued examination under §1.114. No certification or fee is required. 37 C.F.R. §1.97(b).
2. This Information Disclosure Statement is being filed more than three months after the U.S. filing date AND after the mailing date of the first Office Action on the merits, but before the mailing date of a Final Rejection OR Notice of Allowance OR an action that otherwise closes prosecution in the application. 37 C.F.R. §1.97(c).
- a. I hereby state that each item of information contained in this Information Disclosure Statement was first cited in a communication from a foreign patent office in a counterpart foreign application not more than three months prior to the filing of this Information Disclosure Statement. 37 C.F.R. §1.97(e)(1). No fee is required.
- b. I hereby state that no item of information in this Information Disclosure Statement was cited in a communication from a foreign patent office in a counterpart foreign application and, to my knowledge after making reasonable inquiry, was known to any individual designated in 37 C.F.R. §1.56(c) more than three months prior to the filing of this Information Disclosure Statement. 37 C.F.R. §1.97(e)(2). No fee is required.

Ex.1002

APPLE INC. / Page 381 of 825

- c. Please charge our Credit Card in the amount of \$180.00 in payment of the fee under 37 C.F.R. §1.17(p) per the attached PTO 2038 form. Please credit or debit Deposit Account No. 16-0607 as needed to ensure consideration of the disclosed information.
- 3. This Information Disclosure Statement is being filed after the mailing date of a Final Rejection OR Notice of Allowance OR an action that otherwise closes prosecution in the application, but on or before payment of the Issue Fee. Please charge our Credit Card in the amount of \$180.00 in payment of the fee under 37 C.F.R. §1.17(p) per the attached PTO 2038 form. Please credit or debit Deposit Account No. 16-0607 as needed to ensure consideration of the disclosed information. 37 C.F.R. §1.97(d).
 - a. I hereby state that each item of information contained in this Information Disclosure Statement was first cited in a communication from a foreign patent office in a counterpart foreign application not more than three months prior to the filing of this Information Disclosure Statement. 37 C.F.R. §1.97(e)(1).
 - b. I hereby state that no item of information in this Information Disclosure Statement was cited in a communication from a foreign patent office in a counterpart foreign application or, to my knowledge after making reasonable inquiry, was known to any individual designated in 37 C.F.R. §1.56(c) more than three months prior to the filing of this Information Disclosure Statement. 37 C.F.R. §1.97(e)(2).
- 4. To the extent necessary, a petition for an extension of time under 37 C.F.R. §1.136 is hereby made. Please charge any shortage in fees due in connection with the filing of this paper, including extension of time fees, to Deposit Account 16-0607 and please credit any excess fees to such deposit account.

Respectfully submitted,
KED & ASSOCIATES, LLP

Daniel Y.J. Kim
Registration No. 36,186

Correspondence Address:
P.O. Box 8638
Reston, VA 20195
Telephone: (703) 766-3777
DYK/dak

Please direct all correspondence to Customer Number 34610

\\ked2\Documents\2414\2414-049\617206.docx

Docket No.: **DANA-0049**

PATENT

IN THE UNITED STATES PATENT AND TRADEMARK OFFICE

In re Application of

Confirmation No.: **5436**

Seok BAE; Donchul CHOI; and Soon Young HYUN

Group Art Unit: **2859**

Serial No.: **14/901,426**

Examiner: **Drew A. DUNN**

Filed: **December 28, 2015**

Customer No.: **34610**

For: **RECEIVING ANTENNA AND WIRELESS POWER RECEIVING DEVICE
INCLUDING THE SAME**

INFORMATION DISCLOSURE STATEMENT

U.S. Patent and Trademark Office
Customer Service Window
Randolph Building
401 Dulany Street
Alexandria, Virginia 22314

Sir:

Pursuant to 37 C.F.R. §1.56, the attention of the Patent and Trademark Office is hereby directed to the references listed on the attached PTO-1449. One copy of each non-U.S. reference is attached. It is respectfully requested that the information be expressly considered during the prosecution of this application, and that the reference(s) be made of record therein and appear among the "References Cited" on any patent to issue therefrom.

Applicants have listed publication dates on the attached PTO-1449 based on information presently available to the undersigned. However, the listed publication dates should not be construed as an admission that the information was actually published on the indicated date. Applicants reserve the right to establish the patentability of the claimed invention over any of the information provided herewith, and/or to prove that this information may not be prior art, and/or to prove that this information may not be enabling for the teachings purportedly offered. This statement should not be construed as a representation that a search has been made, that information cited in the statement is considered to be and/or is material to patentability, or that information more material to the examination of the present patent application does not exist. The Examiner is specifically requested not to rely solely on the material submitted herewith. It is further understood that the Examiner will consider information that was cited or submitted to the U.S. Patent and Trademark Office in a prior application relied on under 35 U.S.C. §120. 1138 OG 37, 38 (May 19, 1992).

1. This Information Disclosure Statement is being filed (i) within three months of the U.S. filing date of a U.S. application other than a CPA continued prosecution application under §1.53(d) OR (ii) within three months of the date of entry of the national stage as set forth in §1.491 in an international application OR (iii) before the mailing date of a first Office Action on the merits OR (iv) before the mailing of a first Office Action after the filing of a Request for continued examination under §1.114. No certification or fee is required. 37 C.F.R. §1.97(b).
2. This Information Disclosure Statement is being filed more than three months after the U.S. filing date AND after the mailing date of the first Office Action on the merits, but before the mailing date of a Final Rejection OR Notice of Allowance OR an action that otherwise closes prosecution in the application. 37 C.F.R. §1.97(c).
- a. I hereby state that each item of information contained in this Information Disclosure Statement was first cited in a communication from a foreign patent office in a counterpart foreign application not more than three months prior to the filing of this Information Disclosure Statement. 37 C.F.R. §1.97(e)(1). No fee is required.
- b. I hereby state that no item of information in this Information Disclosure Statement was cited in a communication from a foreign patent office in a counterpart foreign application and, to my knowledge after making reasonable inquiry, was known to any individual designated in 37 C.F.R. §1.56(c) more than three months prior to the filing of this Information Disclosure Statement. 37 C.F.R. §1.97(e)(2). No fee is required.

- c. Please charge our Credit Card in the amount of \$180.00 in payment of the fee under 37 C.F.R. §1.17(p) per the attached PTO 2038 form. Please credit or debit Deposit Account No. 16-0607 as needed to ensure consideration of the disclosed information.
- 3. This Information Disclosure Statement is being filed after the mailing date of a Final Rejection OR Notice of Allowance OR an action that otherwise closes prosecution in the application, but on or before payment of the Issue Fee. Please charge our Credit Card in the amount of \$180.00 in payment of the fee under 37 C.F.R. §1.17(p) per the attached PTO 2038 form. Please credit or debit Deposit Account No. 16-0607 as needed to ensure consideration of the disclosed information. 37 C.F.R. §1.97(d).
 - a. I hereby state that each item of information contained in this Information Disclosure Statement was first cited in a communication from a foreign patent office in a counterpart foreign application not more than three months prior to the filing of this Information Disclosure Statement. 37 C.F.R. §1.97(e)(1).
 - b. I hereby state that no item of information in this Information Disclosure Statement was cited in a communication from a foreign patent office in a counterpart foreign application or, to my knowledge after making reasonable inquiry, was known to any individual designated in 37 C.F.R. §1.56(c) more than three months prior to the filing of this Information Disclosure Statement. 37 C.F.R. §1.97(e)(2).
- 4. To the extent necessary, a petition for an extension of time under 37 C.F.R. §1.136 is hereby made. Please charge any shortage in fees due in connection with the filing of this paper, including extension of time fees, to Deposit Account 16-0607 and please credit any excess fees to such deposit account.

Respectfully submitted,
KED & ASSOCIATES, LLP

/Daniel Y.J. Kim/

Daniel Y.J. Kim
Registration No. 36,186

Correspondence Address:
P.O. Box 8638
Reston, VA 20195
Telephone: (703) 766-3777
DYK/dak

Please direct all correspondence to Customer Number 34610

\\ked2\Documents\2414\2414-049\617206.docx

Electronic Acknowledgement Receipt

EFS ID:	27095860
Application Number:	14901426
International Application Number:	
Confirmation Number:	5436
Title of Invention:	RECEIVING ANTENNA AND WIRELESS POWER RECEIVING DEVICE INCLUDING THE SAME
First Named Inventor/Applicant Name:	Seok BAE
Customer Number:	34610
Filer:	Daniel Y.J. Kim/Deborah Kimberlin
Filer Authorized By:	Daniel Y.J. Kim
Attorney Docket Number:	DANA-0049
Receipt Date:	30-SEP-2016
Filing Date:	28-DEC-2015
Time Stamp:	18:56:16
Application Type:	U.S. National Stage under 35 USC 371

Payment information:

Submitted with Payment	no
------------------------	----

File Listing:

Document Number	Document Description	File Name	File Size(Bytes)/ Message Digest	Multi Part /.zip	Pages (if appl.)
1	Transmittal Letter	IDS.pdf	149512 21493ed861802233ae27abf80706b0740b b71df	no	2

Warnings:

Information:	
Total Files Size (in bytes):	149512
<p>This Acknowledgement Receipt evidences receipt on the noted date by the USPTO of the indicated documents, characterized by the applicant, and including page counts, where applicable. It serves as evidence of receipt similar to a Post Card, as described in MPEP 503.</p> <p><u>New Applications Under 35 U.S.C. 111</u> If a new application is being filed and the application includes the necessary components for a filing date (see 37 CFR 1.53(b)-(d) and MPEP 506), a Filing Receipt (37 CFR 1.54) will be issued in due course and the date shown on this Acknowledgement Receipt will establish the filing date of the application.</p> <p><u>National Stage of an International Application under 35 U.S.C. 371</u> If a timely submission to enter the national stage of an international application is compliant with the conditions of 35 U.S.C. 371 and other applicable requirements a Form PCT/DO/EO/903 indicating acceptance of the application as a national stage submission under 35 U.S.C. 371 will be issued in addition to the Filing Receipt, in due course.</p> <p><u>New International Application Filed with the USPTO as a Receiving Office</u> If a new international application is being filed and the international application includes the necessary components for an international filing date (see PCT Article 11 and MPEP 1810), a Notification of the International Application Number and of the International Filing Date (Form PCT/RO/105) will be issued in due course, subject to prescriptions concerning national security, and the date shown on this Acknowledgement Receipt will establish the international filing date of the application.</p>	



UNITED STATES PATENT AND TRADEMARK OFFICE

UNITED STATES DEPARTMENT OF COMMERCE
United States Patent and Trademark Office
Address: COMMISSIONER FOR PATENTS
P.O. Box 1450
Alexandria, Virginia 22313-1450
www.uspto.gov

APPLICATION NUMBER	FILING OR 371(C) DATE	FIRST NAMED APPLICANT	ATTY. DOCKET NO./TITLE
14/901,426	12/28/2015	Seok BAE	DANA-0049

CONFIRMATION NO. 5436

34610
KED & ASSOCIATES, LLP
P.O. Box 8638
Reston, VA 20195

PUBLICATION NOTICE



Title:RECEIVING ANTENNA AND WIRELESS POWER RECEIVING DEVICE INCLUDING THE SAME

Publication No.US-2016-0156103-A1

Publication Date:06/02/2016

NOTICE OF PUBLICATION OF APPLICATION

The above-identified application will be electronically published as a patent application publication pursuant to 37 CFR 1.211, et seq. The patent application publication number and publication date are set forth above.

The publication may be accessed through the USPTO's publically available Searchable Databases via the Internet at www.uspto.gov. The direct link to access the publication is currently <http://www.uspto.gov/patft/>.

The publication process established by the Office does not provide for mailing a copy of the publication to applicant. A copy of the publication may be obtained from the Office upon payment of the appropriate fee set forth in 37 CFR 1.19(a)(1). Orders for copies of patent application publications are handled by the USPTO's Office of Public Records. The Office of Public Records can be reached by telephone at (703) 308-9726 or (800) 972-6382, by facsimile at (703) 305-8759, by mail addressed to the United States Patent and Trademark Office, Office of Public Records, Alexandria, VA 22313-1450 or via the Internet.

In addition, information on the status of the application, including the mailing date of Office actions and the dates of receipt of correspondence filed in the Office, may also be accessed via the Internet through the Patent Electronic Business Center at www.uspto.gov using the public side of the Patent Application Information and Retrieval (PAIR) system. The direct link to access this status information is currently <http://pair.uspto.gov/>. Prior to publication, such status information is confidential and may only be obtained by applicant using the private side of PAIR.

Further assistance in electronically accessing the publication, or about PAIR, is available by calling the Patent Electronic Business Center at 1-866-217-9197.

Office of Data Management, Application Assistance Unit (571) 272-4000, or (571) 272-4200, or 1-888-786-0101



UNITED STATES PATENT AND TRADEMARK OFFICE

UNITED STATES DEPARTMENT OF COMMERCE
United States Patent and Trademark Office
Address: COMMISSIONER FOR PATENTS
P.O. Box 1450
Alexandria, Virginia 22313-1450
www.uspto.gov

APPLICATION NUMBER	FILING OR 371(C) DATE	FIRST NAMED APPLICANT	ATTY. DOCKET NO./TITLE
14/901,426	12/28/2015	Seok BAE	DANA-0049

CONFIRMATION NO. 5436

POA ACCEPTANCE LETTER

34610
KED & ASSOCIATES, LLP
P.O. Box 8638
Reston, VA 20195



Date Mailed: 05/03/2016

NOTICE OF ACCEPTANCE OF POWER OF ATTORNEY

This is in response to the Power of Attorney filed 04/27/2016.

The Power of Attorney in this application is accepted. Correspondence in this application will be mailed to the above address as provided by 37 CFR 1.33.

Questions about the contents of this notice and the requirements it sets forth should be directed to the Office of Data Management, Application Assistance Unit, at (571) 272-4000 or (571) 272-4200 or 1-888-786-0101.

/qtran/



UNITED STATES PATENT AND TRADEMARK OFFICE

UNITED STATES DEPARTMENT OF COMMERCE
United States Patent and Trademark Office
Address: COMMISSIONER FOR PATENTS
P.O. Box 1450
Alexandria, Virginia 22313-1450
www.uspto.gov

Table with 7 columns: APPLICATION NUMBER, FILING or 371(c) DATE, GRP ART UNIT, FIL FEE REC'D, ATTY. DOCKET NO, TOT CLAIMS, IND CLAIMS. Row 1: 14/901,426, 12/28/2015, 2859, 1620, DANA-0049, 20, 3

CONFIRMATION NO. 5436
CORRECTED FILING RECEIPT

34610
KED & ASSOCIATES, LLP
P.O. Box 8638
Reston, VA 20195



Date Mailed: 04/27/2016

Receipt is acknowledged of this non-provisional patent application. The application will be taken up for examination in due course. Applicant will be notified as to the results of the examination. Any correspondence concerning the application must include the following identification information: the U.S. APPLICATION NUMBER, FILING DATE, NAME OF APPLICANT, and TITLE OF INVENTION. Fees transmitted by check or draft are subject to collection. Please verify the accuracy of the data presented on this receipt. If an error is noted on this Filing Receipt, please submit a written request for a Filing Receipt Correction. Please provide a copy of this Filing Receipt with the changes noted thereon. If you received a "Notice to File Missing Parts" for this application, please submit any corrections to this Filing Receipt with your reply to the Notice. When the USPTO processes the reply to the Notice, the USPTO will generate another Filing Receipt incorporating the requested corrections

Inventor(s)

Seok BAE, Seoul, KOREA, REPUBLIC OF;
Donchul CHOI, Seoul, KOREA, REPUBLIC OF;
Soon Young Hyun, Seoul, KOREA, REPUBLIC OF;

Applicant(s)

LG INNOTEK CO., LTD., Seoul, KOREA, REPUBLIC OF;

Power of Attorney: The patent practitioners associated with Customer Number 34610

Domestic Priority data as claimed by applicant

This application is a 371 of PCT/KR2014/005258 06/16/2014

Foreign Applications (You may be eligible to benefit from the Patent Prosecution Highway program at the USPTO. Please see http://www.uspto.gov for more information.)

REPUBLIC OF KOREA 10-2013-0074620 06/27/2013

Permission to Access Application via Priority Document Exchange: No

Permission to Access Search Results: No

Applicant may provide or rescind an authorization for access using Form PTO/SB/39 or Form PTO/SB/69 as appropriate.

If Required, Foreign Filing License Granted: 02/23/2016

The country code and number of your priority application, to be used for filing abroad under the Paris Convention, is US 14/901,426

Projected Publication Date: 06/02/2016

Non-Publication Request: No

Early Publication Request: No
Title

RECEIVING ANTENNA AND WIRELESS POWER RECEIVING DEVICE INCLUDING THE SAME

Preliminary Class

320

Statement under 37 CFR 1.55 or 1.78 for AIA (First Inventor to File) Transition Applications: No

PROTECTING YOUR INVENTION OUTSIDE THE UNITED STATES

Since the rights granted by a U.S. patent extend only throughout the territory of the United States and have no effect in a foreign country, an inventor who wishes patent protection in another country must apply for a patent in a specific country or in regional patent offices. Applicants may wish to consider the filing of an international application under the Patent Cooperation Treaty (PCT). An international (PCT) application generally has the same effect as a regular national patent application in each PCT-member country. The PCT process **simplifies** the filing of patent applications on the same invention in member countries, but **does not result** in a grant of "an international patent" and does not eliminate the need of applicants to file additional documents and fees in countries where patent protection is desired.

Almost every country has its own patent law, and a person desiring a patent in a particular country must make an application for patent in that country in accordance with its particular laws. Since the laws of many countries differ in various respects from the patent law of the United States, applicants are advised to seek guidance from specific foreign countries to ensure that patent rights are not lost prematurely.

Applicants also are advised that in the case of inventions made in the United States, the Director of the USPTO must issue a license before applicants can apply for a patent in a foreign country. The filing of a U.S. patent application serves as a request for a foreign filing license. The application's filing receipt contains further information and guidance as to the status of applicant's license for foreign filing.

Applicants may wish to consult the USPTO booklet, "General Information Concerning Patents" (specifically, the section entitled "Treaties and Foreign Patents") for more information on timeframes and deadlines for filing foreign patent applications. The guide is available either by contacting the USPTO Contact Center at 800-786-9199, or it can be viewed on the USPTO website at <http://www.uspto.gov/web/offices/pac/doc/general/index.html>.

For information on preventing theft of your intellectual property (patents, trademarks and copyrights), you may wish to consult the U.S. Government website, <http://www.stopfakes.gov>. Part of a Department of Commerce initiative, this website includes self-help "toolkits" giving innovators guidance on how to protect intellectual property in specific countries such as China, Korea and Mexico. For questions regarding patent enforcement issues, applicants may call the U.S. Government hotline at 1-866-999-HALT (1-866-999-4258).

LICENSE FOR FOREIGN FILING UNDER
Title 35, United States Code, Section 184
Title 37, Code of Federal Regulations, 5.11 & 5.15

GRANTED

The applicant has been granted a license under 35 U.S.C. 184, if the phrase "IF REQUIRED, FOREIGN FILING LICENSE GRANTED" followed by a date appears on this form. Such licenses are issued in all applications where the conditions for issuance of a license have been met, regardless of whether or not a license may be required as set forth in 37 CFR 5.15. The scope and limitations of this license are set forth in 37 CFR 5.15(a) unless an earlier license has been issued under 37 CFR 5.15(b). The license is subject to revocation upon written notification. The date indicated is the effective date of the license, unless an earlier license of similar scope has been granted under 37 CFR 5.13 or 5.14.

This license is to be retained by the licensee and may be used at any time on or after the effective date thereof unless it is revoked. This license is automatically transferred to any related applications(s) filed under 37 CFR 1.53(d). This license is not retroactive.

The grant of a license does not in any way lessen the responsibility of a licensee for the security of the subject matter as imposed by any Government contract or the provisions of existing laws relating to espionage and the national security or the export of technical data. Licensees should apprise themselves of current regulations especially with respect to certain countries, of other agencies, particularly the Office of Defense Trade Controls, Department of State (with respect to Arms, Munitions and Implements of War (22 CFR 121-128)); the Bureau of Industry and Security, Department of Commerce (15 CFR parts 730-774); the Office of Foreign Assets Control, Department of Treasury (31 CFR Parts 500+) and the Department of Energy.

NOT GRANTED

No license under 35 U.S.C. 184 has been granted at this time, if the phrase "IF REQUIRED, FOREIGN FILING LICENSE GRANTED" DOES NOT appear on this form. Applicant may still petition for a license under 37 CFR 5.12, if a license is desired before the expiration of 6 months from the filing date of the application. If 6 months has lapsed from the filing date of this application and the licensee has not received any indication of a secrecy order under 35 U.S.C. 181, the licensee may foreign file the application pursuant to 37 CFR 5.15(b).

SelectUSA

The United States represents the largest, most dynamic marketplace in the world and is an unparalleled location for business investment, innovation, and commercialization of new technologies. The U.S. offers tremendous resources and advantages for those who invest and manufacture goods here. Through SelectUSA, our nation works to promote and facilitate business investment. SelectUSA provides information assistance to the international investor community; serves as an ombudsman for existing and potential investors; advocates on behalf of U.S. cities, states, and regions competing for global investment; and counsels U.S. economic development organizations on investment attraction best practices. To learn more about why the United States is the best country in the world to develop technology, manufacture products, deliver services, and grow your business, visit <http://www.SelectUSA.gov> or call +1-202-482-6800.

Docket No.: **DANA-0049**

PATENT

IN THE UNITED STATES PATENT AND TRADEMARK OFFICE

In re Application of: Confirmation No.: **5436**
Seok BAE; Donchul CHOI; and Group Art Unit: **2859**
Soon Young HYUN
Serial No.: **14/901,426** Examiner: **To Be Assigned**
Filed: **December 28, 2015** Customer No.: **34610**
For: **RECEIVING ANTENNA AND WIRELESS POWER RECEIVING DEVICE**
INCLUDING THE SAME

SUBMISSION OF DECLARATIONS AND POWER OF ATTORNEY

U.S. Patent and Trademark Office
Customer Service Window, **BOX PCT**
Randolph Building
401 Dulany Street
Alexandria, VA 22314

Sir:

Further to the Notice of Acceptance dated **February 25, 2016**, submitted herewith are the following documents for filing in the above-referenced application:

- Substitute Statements in Lieu of Oath or Declaration and Declaration.**
- Power of Attorney.**
- Statement Under 37 C.F.R. §3.73(c).**
- Late filing surcharge of \$140.00 (large entity) (Previously submitted on December 28, 2015).**

It is requested that an Official Filing Receipt showing the data contained herewith now be issued.

Please charge any shortage in fees due in connection with the filing of this paper, including extension of time fees, to Deposit Account 16-0607 and please credit any excess fees to such deposit account.

Respectfully submitted,
KED & ASSOCIATES, LLP

/Daniel Y.J. Kim/

Daniel Y.J. Kim
Registration No. 36,186

Correspondence Address:

P.O. Box 8638

Reston, VA 20195

703 766-3777 DYK/seg

Please direct all correspondence to Customer Number 34610

Q:\Documents\2414-049\582796.docx

Under the Paperwork Reduction Act of 1995, no persons are required to respond to a collection of information unless it displays a valid OMB control number.

POWER OF ATTORNEY TO PROSECUTE APPLICATIONS BEFORE THE USPTO

I hereby revoke all previous powers of attorney given in the application identified in the attached statement under 37 CFR 3.73(c).

I hereby appoint:

Practitioners associated with Customer Number: 34610

OR

Practitioner(s) named below (if more than ten patent practitioners are to be named, then a customer number must be used):

Name	Registration Number	Name	Registration Number

As attorney(s) or agent(s) to represent the undersigned before the United States Patent and Trademark Office (USPTO) in connection with any and all patent applications assigned only to the undersigned according to the USPTO assignment records or assignments documents attached to this form in accordance with 37 CFR 3.73(c).

Please change the correspondence address for the application identified in the attached statement under 37 CFR 3.73(c) to:

The address associated with Customer Number: 34610

OR

Firm or Individual Name			
Address			
City	State	Zip	
Country			
Telephone	Email		

Assignee Name and Address: *LG Innotek Co., Ltd.*
Saemil Square, 416, Hongyong-Daero, Jung-gu
Seoul 100-710, Republic of Korea

A copy of this form, together with a statement under 37 CFR 3.73(c) (Form PTO/AIA/96 or equivalent) is required to be filed in each application in which this form is used. The statement under 37 CFR 3.73(c) may be completed by one of the practitioners appointed in this form, and must identify the application in which this Power of Attorney is to be filed.

SIGNATURE of Assignee of Record

The individual whose signature and title is supplied below is authorized to act on behalf of the assignee

Signature	<i>[Handwritten Signature]</i>	Date	June 18th, 2014
Name	Mr. Gyoung Rae KIM	Telephone	+82-31-436-9871
Title	Senior Manager		

This collection of information is required by 37 CFR 1.31, 1.32 and 1.33. The information is required to obtain or retain a benefit by the public which is to file (and by the USPTO to process) an application. Confidentiality is governed by 35 U.S.C. 122 and 37 CFR 1.11 and 1.14. This collection is estimated to take 3 minutes to complete, including gathering, preparing, and submitting the completed application form to the USPTO. Time will vary depending upon the individual case. Any comments on the amount of time you require to complete this form and/or suggestions for reducing this burden, should be sent to the Chief Information Officer, U.S. Patent and Trademark Office, U.S. Department of Commerce, P.O. Box 1450, Alexandria, VA 22313-1450. DO NOT SEND FEES OR COMPLETED FORMS TO THIS ADDRESS. SEND TO: Commissioner for Patents, P.O. Box 1450, Alexandria, VA 22313-1450.

If you need assistance in completing the form, call 1-800-PTO-9199 and select option 2.

STATEMENT UNDER 37 CFR 3.73(c)Applicant/Patent Owner: LG INNOTEK CO., LTD.Application No./Patent No.: 14/901,426 Filed/Issue Date: December 28, 2015Titled: RECEIVING ANTENNA AND WIRELESS POWER RECEIVING DEVICE INCLUDING THE SAMELG INNOTEK CO., LTD., a corporation

(Name of Assignee)

(Type of Assignee, e.g., corporation, partnership, university, government agency, etc.)

states that, for the patent application/patent identified above, it is (choose **one** of options 1, 2, 3 or 4 below):

1. The assignee of the entire right, title, and interest.
2. An assignee of less than the entire right, title, and interest (check applicable box):
- The extent (by percentage) of its ownership interest is _____%. Additional Statement(s) by the owners holding the balance of the interest must be submitted to account for 100% of the ownership interest.
- There are unspecified percentages of ownership. The other parties, including inventors, who together own the entire right, title and interest are:

Additional Statement(s) by the owner(s) holding the balance of the interest must be submitted to account for the entire right, title, and interest.

3. The assignee of an undivided interest in the entirety (a complete assignment from one of the joint inventors was made). The other parties, including inventors, who together own the entire right, title, and interest are:

Additional Statement(s) by the owner(s) holding the balance of the interest must be submitted to account for the entire right, title, and interest.

4. The recipient, via a court proceeding or the like (e.g., bankruptcy, probate), of an undivided interest in the entirety (a complete transfer of ownership interest was made). The certified document(s) showing the transfer is attached.

The interest identified in option 1, 2 or 3 above (not option 4) is evidenced by either (choose **one** of options A or B below):

- A. An assignment from the inventor(s) of the patent application/patent identified above. The assignment was recorded in the United States Patent and Trademark Office at Reel _____, Frame _____, or for which a copy thereof is attached.

- B. A chain of title from the inventor(s), of the patent application/patent identified above, to the current assignee as follows:

1. From: _____ To: _____

The document was recorded in the United States Patent and Trademark Office at

Reel _____, Frame _____, or for which a copy thereof is attached.

2. From: _____ To: _____

The document was recorded in the United States Patent and Trademark Office at

Reel _____, Frame _____, or for which a copy thereof is attached.

[Page 1 of 2]

This collection of information is required by 37 CFR 3.73(b). The information is required to obtain or retain a benefit by the public which is to file (and by the USPTO to process) an application. Confidentiality is governed by 35 U.S.C. 122 and 37 CFR 1.11 and 1.14. This collection is estimated to take 12 minutes to complete, including gathering, preparing, and submitting the completed application form to the USPTO. Time will vary depending upon the individual case. Any comments on the amount of time you require to complete this form and/or suggestions for reducing this burden, should be sent to the Chief Information Officer, U.S. Patent and Trademark Office, U.S. Department of Commerce, P.O. Box 1450, Alexandria, VA 22313-1450. DO NOT SEND FEES OR COMPLETED FORMS TO THIS ADDRESS. **SEND TO: Commissioner for Patents, P.O. Box 1450, Alexandria, VA 22313-1450.**

If you need assistance in completing the form, call 1-800-PTO-9199 and select option 2.

STATEMENT UNDER 37 CFR 3.73(c)

3. From: _____ To: _____

The document was recorded in the United States Patent and Trademark Office at
Reel _____, Frame _____, or for which a copy thereof is attached.

4. From: _____ To: _____

The document was recorded in the United States Patent and Trademark Office at
Reel _____, Frame _____, or for which a copy thereof is attached.

5. From: _____ To: _____

The document was recorded in the United States Patent and Trademark Office at
Reel _____, Frame _____, or for which a copy thereof is attached.

6. From: _____ To: _____

The document was recorded in the United States Patent and Trademark Office at
Reel _____, Frame _____, or for which a copy thereof is attached.

Additional documents in the chain of title are listed on a supplemental sheet(s).

As required by 37 CFR 3.73(c)(1)(i), the documentary evidence of the chain of title from the original owner to the assignee was, or concurrently is being, submitted for recordation pursuant to 37 CFR 3.11.

[NOTE: A separate copy (i.e., a true copy of the original assignment document(s)) must be submitted to Assignment Division in accordance with 37 CFR Part 3, to record the assignment in the records of the USPTO. See MPEP 302.08]

The undersigned (whose title is supplied below) is authorized to act on behalf of the assignee.

/Daniel Y.J. Kim/

April 20, 2016

Signature

Date

Daniel Y.J. Kim

36,186

Printed or Typed Name

Title or Registration Number

Docket No.: DANA-0049

ASSIGNMENT

In consideration of the premises and other good and valuable consideration in hand paid, the receipt and sufficiency of which is hereby acknowledged, the undersigned,

- (1) BAE, Seok (4) _____
- (2) CHOI, Don Cbul (5) _____
- (3) HYUN, Soon Young (6) _____

who have made a certain new and useful invention, hereby sell, assign and transfer unto

LG INNOTEK CO., LTD.

Seoul Square, 416, Hangang-daero, Jung-gu,

Seoul, 100-714 Republic of Korea

its successors and assigns (hereinafter designated "ASSIGNEE") the entire right, title and interest for the United States of America as defined in 35 U.S.C. 100 in the invention entitled:

RECEIVING ANTENNA AND WIRELESS POWER RECEIVING DEVICE INCLUDING THE SAME

(a) for which an application for United States Letters Patent was filed on 12/28/2015, and identified by United States Serial No. 14/901,426; or

(b) for which an application for United States Letters Patent was executed on _____;

and the undersigned hereby authorize and request the United States Commissioner of Patents and Trademarks to issue any and all United States Letters Patent which may be granted therefor and/or that claim priority thereto and any and all extensions, divisions, reissues, substitutes, renewals, continuations, or continuations-in-part thereof and/or that claim priority thereto, and the right to all benefits under the International Convention for the Protection of Industrial Property to the said ASSIGNEE, for its interest as ASSIGNEE, its successors, assigns and legal representatives; the undersigned agree that the attorneys of record in said application shall hereafter act on behalf of said ASSIGNEE.

AND the undersigned hereby agree to transfer a like interest, and to render all necessary assistance in making application for and obtaining original, divisional, reissued or extended Letters Patent of the United States, upon request of the said ASSIGNEE, its successors, assigns and legal representatives, and without further remuneration, in and to any improvements, and applications for patent based thereon, growing out of or related to the said invention; and to execute any papers by the said ASSIGNEE, its successors, assigns and legal representatives, deemed essential to ASSIGNEE's full protection and title in and to the invention hereby transferred.

AND the undersigned hereby grants the firm of KED & ASSOCIATES, LLP the power to insert on this assignment any further identification that may be necessary or desirable in order to comply with the rules of any issuing authority, including the United States Patent and Trademark Office, for recordation of this document.

SIGNED on the dates indicated aside our signatures:

INVENTORS	DATE SIGNED
1) <u>BAE, Seok</u> Name: <u>BAE, Seok</u>	<u>2. MAR. 2016</u>
2) _____ Name: <u>CHOI, Don Cbul</u>	_____
3) _____ Name: <u>HYUN, Soon Young</u>	_____
4) _____ Name: _____	_____
5) _____ Name: _____	_____
6) _____	_____

Under the Paperwork Reduction Act of 1995, no persons are required to respond to a collection of information unless it displays a valid GMB control number.

DECLARATION (37 CFR 1.63) FOR UTILITY OR DESIGN APPLICATION USING AN APPLICATION DATA SHEET (37 CFR 1.76)

Title of Invention	RECEIVING ANTENNA AND WIRELESS POWER RECEIVING DEVICE INCLUDING THE SAME
---------------------------	---------------------------------------------------------------------------------

As the below named inventor, I hereby declare that:

This declaration is directed to: The attached application, or United States application or PCT international application number PCT/KR2014/005258 filed on June 16, 2014

The above-identified application was made or authorized to be made by me.

I believe that I am the original inventor or an original joint inventor of a claimed invention in the application.

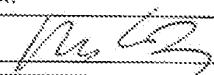
I hereby acknowledge that any willful false statement made in this declaration is punishable under 18 U.S.C. 1001 by fine or imprisonment of not more than five (5) years, or both.

WARNING:

Petitioner/applicant is cautioned to avoid submitting personal information in documents filed in a patent application that may contribute to identity theft. Personal information such as social security numbers, bank account numbers, or credit card numbers (other than a check or credit card authorization form PTO-2036 submitted for payment purposes) is never required by the USPTO to support a petition or an application. If this type of personal information is included in documents submitted to the USPTO, petitioners/applicants should consider redacting such personal information from the documents before submitting them to the USPTO. Petitioner/applicant is advised that the record of a patent application is available to the public after publication of the application (unless a non-publication request in compliance with 37 CFR 1.213(a) is made in the application) or issuance of a patent. Furthermore, the record from an abandoned application may also be available to the public if the application is referenced in a published application or an issued patent (see 37 CFR 1.14). Checks and credit card authorization forms PTO-2036 submitted for payment purposes are not retained in the application file and therefore are not publicly available.

LEGAL NAME OF INVENTOR

Inventor: BAE, Seok Date (Optional): DEC. 24, 2015

Signature: 

Note: An application data sheet (PTO/SB/14 or equivalent), including naming the entire inventive entity, must accompany this form or must have been previously filed. Use an additional PTO/AIA/01 form for each additional inventor.

This collection of information is required by 35 U.S.C. 115 and 37 CFR 1.63. The information is required to obtain or retain a benefit by the public which is to file (and by the USPTO to process) an application. Confidentiality is governed by 35 U.S.C. 122 and 37 CFR 1.11 and 1.14. This collection is estimated to take 1 minute to complete, including gathering, preparing, and submitting the completed application form to the USPTO. Time will vary depending upon the individual case. Any comments on the amount of time you require to complete this form and/or suggestions for reducing this burden, should be sent to the Chief Information Officer, U.S. Patent and Trademark Office, U.S. Department of Commerce, P.O. Box 1450, Alexandria, VA 22313-1450. DO NOT SEND FEES OR COMPLETED FORMS TO THIS ADDRESS. SEND TO: Commissioner for Patents, P.O. Box 1450, Alexandria, VA 22313-1450.

If you need assistance in completing the form, call 1-800-PTO-9199 and select option 2.