



US006122682A

United States Patent [19]

[11] **Patent Number:** 6,122,682

Andrews

[45] **Date of Patent:** Sep. 19, 2000

[54] **COMMUNICATION SYSTEM FOR CONTROLLING DATA PROCESSING ACCORDING TO A STATE OF A COMMUNICATION TERMINAL DEVICE**

5,475,599 12/1995 Yokoyama et al. 364/449
5,539,810 7/1996 Kennedy, III et al. .
5,893,894 4/1999 Moroto et al. 701/53

[75] Inventor: **Scott Andrews**, Seto, Japan
[73] Assignee: **Toyota Jidosha Kabushiki Kaisha**,
Toyota, Japan

FOREIGN PATENT DOCUMENTS

0751639 1/1997 European Pat. Off. .
0768632 4/1997 European Pat. Off. .
19517126 11/1995 Germany .
5-89399 4/1993 Japan .
7-332997 12/1995 Japan .
98/43192 10/1998 WIPO .

[21] Appl. No.: **09/045,644**

[22] Filed: **Mar. 23, 1998**

[30] Foreign Application Priority Data

Mar. 24, 1997 [JP] Japan 9-070031

[51] **Int. Cl.⁷** **G06F 13/00**

[52] **U.S. Cl.** **710/65; 710/14; 710/65; 701/211**

[58] **Field of Search** 701/211, 220;
340/995, 996; 710/38, 65, 69, 106, 131,
14

Primary Examiner—Thomas C. Lee
Assistant Examiner—Chun Cao
Attorney, Agent, or Firm—Pillsbury Madison & Sutro LLP

[57] ABSTRACT

A subject is to select a type of an output depending on a user's state. A file type recognizer (14) recognizes whether an incoming file has audio data, graphic data, or text data, and informs a command processor (26) of it. The command processor (26) determines whether a vehicle is in motion or not by a detection result from a motion/speed sensor (28), and controls a graphic/audio converter (20) and a text/audio converter (24). If a vehicle is in motion, text data is converted to audio data by the text/audio converter (24) and output from a speaker (18). Graphic data is converted into an audio summary by a graphic data converter and output from the speaker (18).

[56] References Cited

U.S. PATENT DOCUMENTS

5,144,318 9/1992 Kishi 342/357
5,148,153 9/1992 Haymond .
5,303,343 4/1994 Ohya et al. 395/200
5,406,492 4/1995 Suzuki 364/449
5,410,486 4/1995 Kishi et al. 364/449

8 Claims, 2 Drawing Sheets

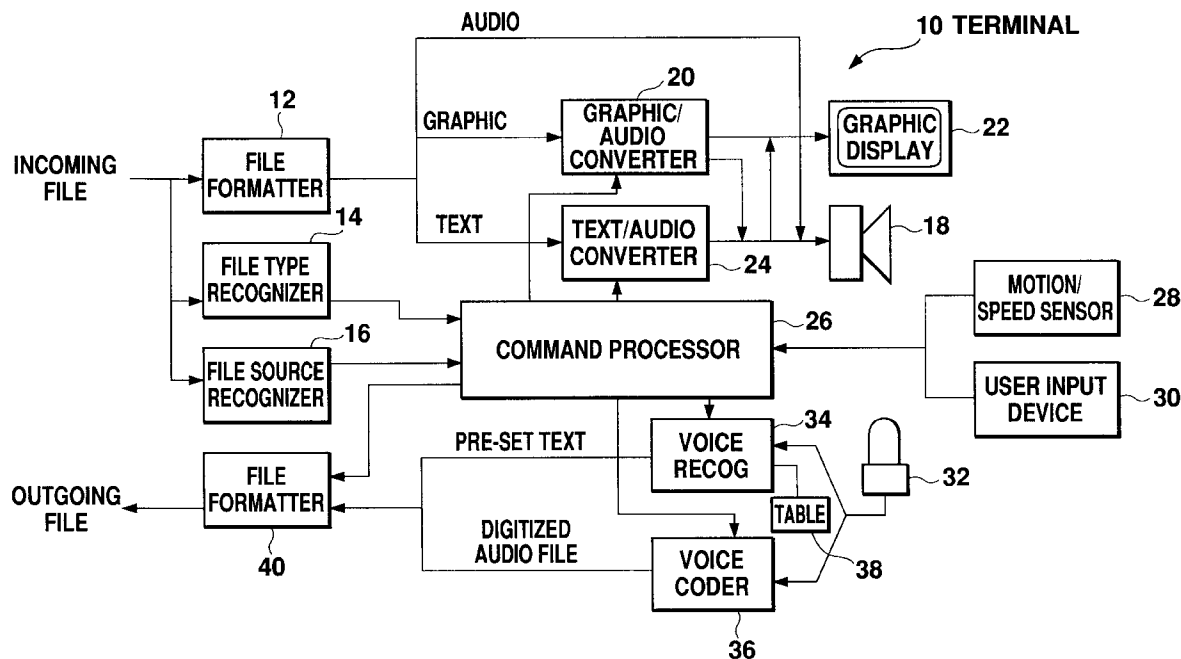

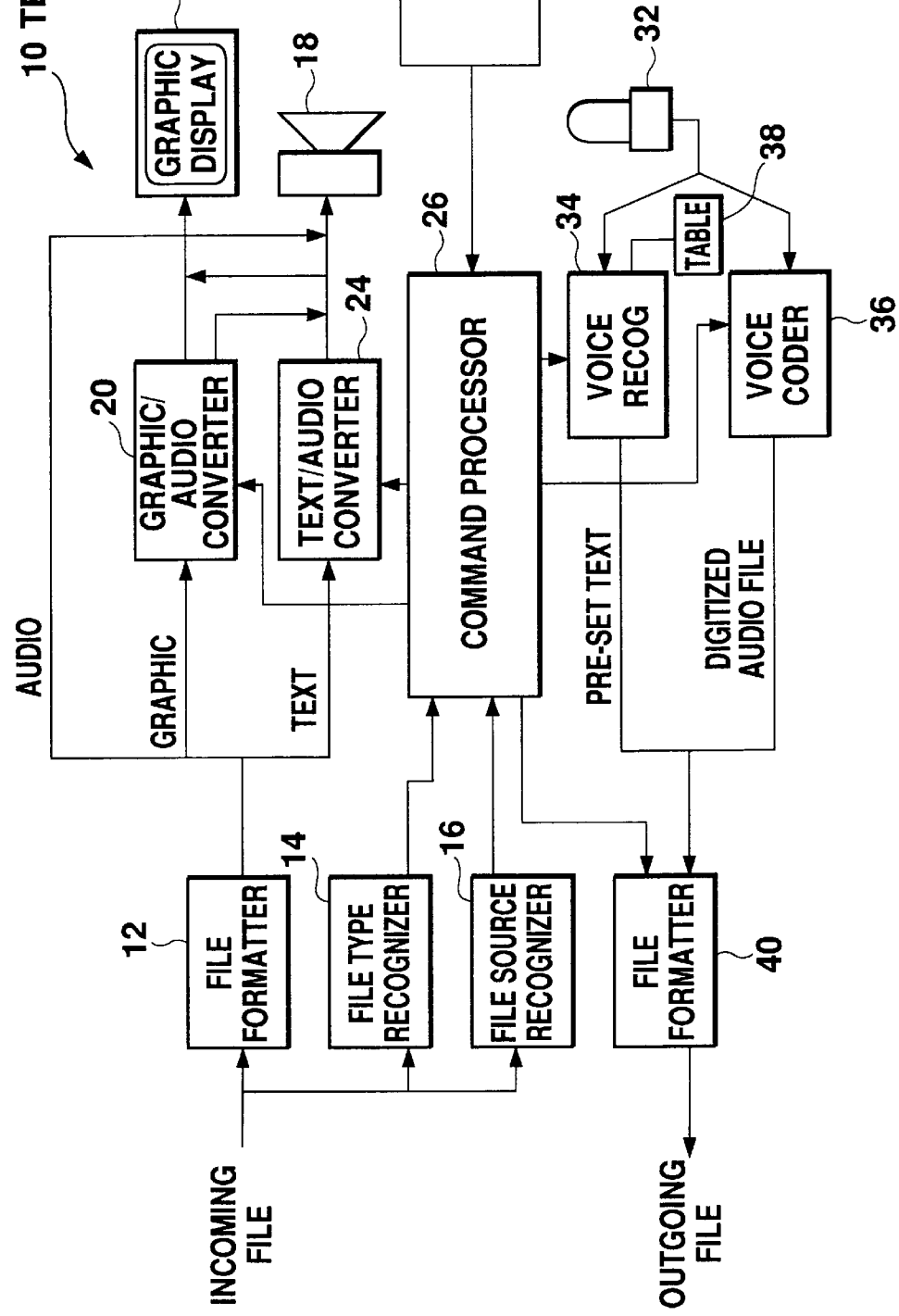

Fig. 1

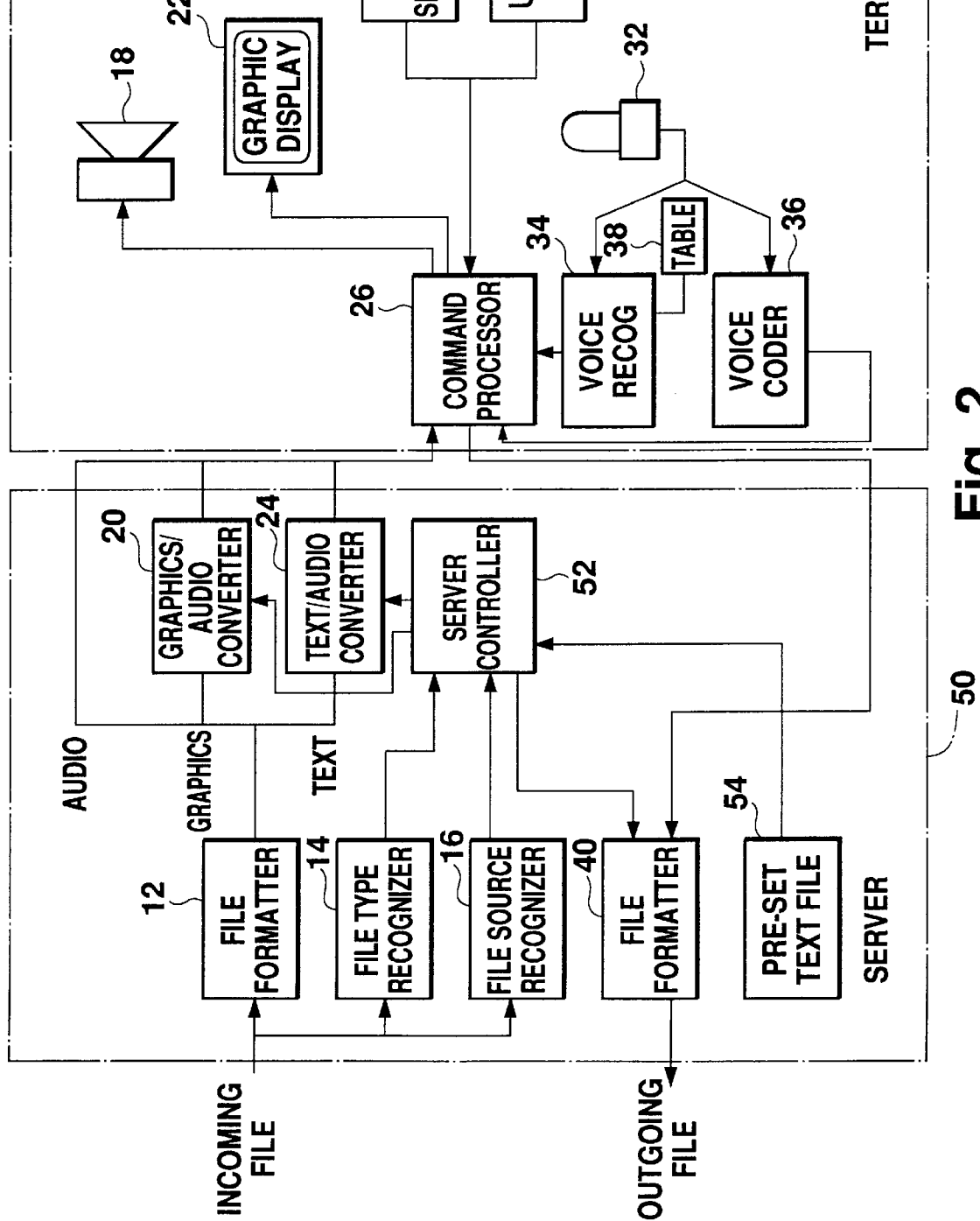

Fig. 2

**COMMUNICATION SYSTEM FOR
CONTROLLING DATA PROCESSING
ACCORDING TO A STATE OF A
COMMUNICATION TERMINAL DEVICE**

BACKGROUND OF THE INVENTION

1. Field of the Invention

The present invention relates to a communications terminal device, a communications system, and a storing medium for storing a program to control data processing by the communications terminal device. More specifically, it is related to the systems that convert received data into an appropriate data type using the communications terminal device.

2. Description of the Prior Art

In accordance with recent development of electronic communications technologies, a plurality of data communications has been available. Especially, with down-sizing of communications terminals and popularity of mobile communications, in-vehicle terminals and portable terminals are being widely used.

For example, Japanese Patent Laid-Open Publications No. Hei 5-89399 shows a system of communications between a mobile terminal in a vehicle, and a traffic information center. By this system, it is possible for a mobile terminal to down-load traffic information and display it on screen. Therefore, it is possible by this system to receive information from a traffic information center upon necessity while a vehicle is in motion.

However, the interface (man-machine interface) between the user and conventional in-vehicle or portable terminals has not been good enough. In other words, a user will be greatly influenced by an ever-changing environment when using an in-vehicle or portable terminal. Conventional terminals have not dealt with this problem. For example, a driver should pay attention to the surroundings while driving, so he cannot watch a display with full attention. However, a conventional in-vehicle terminal only displays text data when it is sent, which is not convenient for a user. Also, depending on the situation in which a communications terminal is placed, audio outputs may not be appropriate. For example, a user does not want to hear an audio message from a portable terminal during a meeting. Insufficient attention has been given for cases like this.

SUMMARY OF THE INVENTION

The present invention is created to solve problems like the above. It is also intended to provide a communications terminal and a system which optimizes the output based on a user's state, and a storage medium to store a program to control these.

This invention relates to a communications terminal used in a communications system, comprising means for receiving incoming data being transmitted, means for detecting the data type of the data received, means for detecting the state in which the communications terminal is placed, means for converting received data into an appropriate data type depending on the data type detected by the detection means and the state detected by the state detection means, and means for outputting the converted data in a manner indicated by the data type.

As described above, in this invention, state detection means detect a state in which a communications terminal is placed. Based on this state, The communications terminal determines an output data type and performs conversion of

the data into a data type appropriate for a user. For example, if a user is in a moving car, text data is converted to, and is output as audio data. By this method, information is provided in an appropriate form to a user who is driving a vehicle.

Another aspect of this invention comprises a table which stores relationships between states and data types which are appropriate for each state, and means for comparing the data type which the state detection means decide to be appropriate for the state and the data type of the received data which is detected by the data type detection means. The conversion means described above change the data type of the received data if the data types above compared by the comparing means disagree. By having this table, the best output type is easily determined. The above communications terminal device is located in a vehicle, and the state detection means detect a state of a vehicle motion. By detecting the state of a car in motion using a speed sensor and the like, the state of the driver who is a user should be detected and an appropriate output form for the user should be chosen.

This invention has at least a text type and an audio type as data types to be transmitted. The outputting means comprise a display and a speaker. The converting means decide, only if the received data is text data, whether the original text data is output as it is or as audio data converted from it.

A further aspect of the present invention comprises means for inputting data, means for composing an outgoing data in a plurality of format types, based on the data input by the inputting means, means for inferring a type of the outgoing data suitable for a communications terminal device to receive the data, and means for transmitting the outgoing data composed by the composing means. It composes the outgoing data using the composing means in a type inferred by the inferring means, and transmits the composed outgoing data by the transmitting means. By considering the state of a sender, a recipient should reply in a format suitable for that sender's state.

This invention is also a communications system in a plurality of data types. The transmitter transmits data in predetermined formats. The receiver recognizes a format of the data received, detects the state of the receiver, converts the data type of the received data to a type suitable for the receiver's detected state, and outputs the converted data. By this communications system the above described selection of an output data type can be done. It is also preferable to communicate not only via communications terminals but also via a fixed communications center and the like. In this case, a communications center has means for conversion so that down-sizing of a communications terminal is realized.

This invention is also a storing medium to store a program to control data processing by the communications terminal. It stores a program to detect the type of data received, to detect a state of a receiver, and to convert the received data to a suitable data type, in accordance with the type of data received and the state of the receiver.

BRIEF DESCRIPTION OF THE DRAWINGS

FIG. 1 is a block diagram showing a configuration of a communications terminal device related to an embodiment of the present invention.

FIG. 2 is a block diagram showing another configuration of a communications terminal device related to the embodiment of the present invention.

**DESCRIPTION OF THE PREFERRED
EMBODIMENTS**

Preferred embodiments of the present invention will now be described with reference to the accompanying figures.

Explanation of the Whole System

FIG. 1 is a block diagram showing a configuration of a communications terminal device related to the present embodiment. An incoming file transmitted from outside is input as a demodulated input file via a cellular phone and a modem. This input file is supplied to a file formatter 12, a file type recognizer 14, and a file source recognizer 16. The file formatter 12 arranges the form of a file (i.e., format) suitable for the data type of the input data. The file type recognizer 14 recognizes a data type if it is an audio file, a graphic file or a text file. The file source recognizer 16 recognizes a type of a transmitter terminal by a content of the input file. In other words, it recognizes if the terminal is an in-vehicle, a portable, or a fixed one. The file type and the type of the transmitter terminal are recorded in a header of a communication file which is at the beginning of the communication file. It is also preferable to add a state of the terminal (i.e., in-motion, or stationary) and a request for a data type of a replying file to the communication file if the transmitter is an in-vehicle or a portable one.

Audio data from the file formatter 12 is supplied to a speaker 18 where it is output. Graphic data is supplied to a graphic data converter 20 where conversion of the data format is performed if necessary. In other words, if conversion is necessary, audio signals to explain the content of the graphic data are generated. Graphic data which was not converted by the graphic data converter 20 is supplied to a graphic display 22 and displayed as it is. Audio signals obtained by the graphic data converter 20 are supplied to the speaker 18 and output thereby. Text data supplied from the file formatter 12 is supplied to a text data converter 24. The text data converter 4 then converts the text data into audio data. In other words, audio signals corresponding to each word of the text data are synthesized. Text data which was not converted by the text data converter 24 is supplied to the graphic display 22 as it is and displayed thereby. If the text data converter 24 converts text data to audio signals, the audio signals obtained are supplied to the speaker 18 and output thereby.

A command processor 26 controls each process of the present communications terminal, based on the incoming information. Recognition results from the file type recognizer 14 and the file source recognizer 16 are provided to the command processor 26. Information about vehicle speed detected by a motion/speed sensor 28 and the commands from a user input device 30 are also provided to the command processor 26. The user input device 30 comprises a keyboard and the like. The command processor 26 determines the state of the user (in this case a driver), based on a motion/speed sensor 28, in this case based on a speed of a vehicle. Based on the state recognized, the command processor 26 controls the graphic/audio converter 20 and

decides whether conversion to an audio data should be performed or not. In other words, if a vehicle is in motion, conversion is done by the graphic/audio converter or the text/audio converter, and an input file (graphic or text data) is converted to an audio data and output from the speaker 18.

The present communications terminal device 10 has a microphone 32 as an input device. A user can input audio signals via the microphone 32. The audio signals input through the microphone 32 are supplied to both a voice recognizer 34 and a voice coder 36. A table 38 is connected to the voice recognizer 34. The voice recognizer 34 recognizes limited voice sounds and reads out a corresponding text data from the table 38. For example, if the input voice sounds are "driving, later", text such as "I am driving. I will respond later." is composed. By inputting a number such as 1, 2, 3, . . . through the microphone, it is also possible to read out a corresponding text data. It is also possible to output a pre-recorded guide message from the speaker 18 and select a text data by replying through the microphone 32.

The voice coder 36 codes audio signals by a method such as PCM, and obtains a digitized audio file. The text data obtained by the voice recognizer 34 and the digitized audio file obtained by the voice coder 36 are provided to a file formatter 40. Text data from the command processor 26 is also provided to the file formatter 40. This text data is, for example, an input from the user input device 30. The file formatter 40 formats incoming data into a format suitable for transmission, and sends it out as an output file. This output is performed via a cellular phone and a modem. Means for transmitting or receiving data can be of any type such as one that directly uses a communications satellite channel.

In a communications terminal 10 of the present embodiment, the command processor 26 decides an output data type, based on a vehicle motion recognized by the motion/speed sensor 28 and a type of the transmitter recognized by the file source recognizer 16. For example, if a vehicle is in motion, the command processor 26 automatically selects the microphone as a replying method and waits for an input by a user. It is also preferable to output a guide message from the speaker. The voice coder then transmits a digitized audio file. If it is known that a recipient is at a meeting, it is preferable to transmit a text data generated by the voice recognizer 34.

Explanation about Data Conversion

Data conversion upon receipt is now explained referring to Table 1. A case of in-vehicle communications terminal was explained in the above embodiment, but cases of portable communication terminal are included in the Table 1.

TABLE 1

| CURRENT STATE | RECEIVER CONTROL TABLE EXAMPLE | | | | |
|------------------|--------------------------------|-------|----------------|---------------|---------------|
| | TEXT | AUDIO | IMAGE/ GRAPHIC | HTML/ VRML | APPLET |
| IN CAR-MOVING | AUDIO | AUDIO | AUDIO SUMMARY | AUDIO SUMMARY | AUDIO SUMMARY |
| IN CAR-STOPPED | TEXT | AUDIO | I/G | HTML/VRML | APPLET |
| PORTABLE-MOVING | AUDIO | AUDIO | AUDIO SUMMARY | AUDIO SUMMARY | AUDIO SUMMARY |
| PORTABLE-STOPPED | TEXT | AUDIO | I/G | HTML/VRML | APPLET |
| PORTABLE- | TEXT | TEXT | I/G | HTML/VRML | APPLET |

Explore Litigation Insights

Docket Alarm provides insights to develop a more informed litigation strategy and the peace of mind of knowing you're on top of things.

Real-Time Litigation Alerts



Keep your litigation team up-to-date with **real-time alerts** and advanced team management tools built for the enterprise, all while greatly reducing PACER spend.

Our comprehensive service means we can handle Federal, State, and Administrative courts across the country.

Advanced Docket Research



With over 230 million records, Docket Alarm's cloud-native docket research platform finds what other services can't. Coverage includes Federal, State, plus PTAB, TTAB, ITC and NLRB decisions, all in one place.

Identify arguments that have been successful in the past with full text, pinpoint searching. Link to case law cited within any court document via Fastcase.

Analytics At Your Fingertips



Learn what happened the last time a particular judge, opposing counsel or company faced cases similar to yours.

Advanced out-of-the-box PTAB and TTAB analytics are always at your fingertips.

API

Docket Alarm offers a powerful API (application programming interface) to developers that want to integrate case filings into their apps.

LAW FIRMS

Build custom dashboards for your attorneys and clients with live data direct from the court.

Automate many repetitive legal tasks like conflict checks, document management, and marketing.

FINANCIAL INSTITUTIONS

Litigation and bankruptcy checks for companies and debtors.

E-DISCOVERY AND LEGAL VENDORS

Sync your system to PACER to automate legal marketing.