



US005818568A

**United States Patent** [19]  
**Onaga et al.**

[11] **Patent Number:** **5,818,568**  
[45] **Date of Patent:** **Oct. 6, 1998**

[54] **EYEGLASS FRAME ASSEMBLY HAVING SCREW-LESS HINGES**

[75] Inventors: **Mikio Onaga; Chikao Uchida; Yoshikazu Takahashi**, all of Fukui-ken, Japan

[73] Assignees: **Eye-Protector Kobayashi Inc.; Kabushiki Kaisha Onaga Megane**, both of Fukui-ken, Japan

[21] Appl. No.: **852,414**

[22] Filed: **May 7, 1997**

[51] **Int. Cl.<sup>6</sup>** ..... **G02C 5/22**

[52] **U.S. Cl.** ..... **351/153; 351/89; 16/228**

[58] **Field of Search** ..... **351/111, 113, 351/119, 116, 121, 106, 153, 89; 16/228**

[56] **References Cited**

**U.S. PATENT DOCUMENTS**

5,135,296 8/1992 Linberg et al. .... 351/106

*Primary Examiner*—Huy Mai

*Attorney, Agent, or Firm*—Nikaido, Marmelstein, Murray & Oram LLP

[57] **ABSTRACT**

Disclosed is an improved eyeglass frame assembly having screw-less hinges. It comprises a front comprising two rims each embracing a lens "L" and a bridge connecting these rims "R" by their inner sides; and a pair of temples "T" each rotatably connected to the outer side of each rim. Each rim "R" is an open-loop metal wire having two holding projections 1, 1 formed at its opposite open ends. Each temple "T" has an arc-like hook 31 formed at its end, and the hook 31 has a vertical stopper 32 formed at its end. The frame assembly further comprises two holder pieces 2, 2, each having two holes 21, 21 to accommodate the two parallel holding projections 1, 1. The arc-like hook 31 embraces each holder piece 2, permitting the temple "T" to rotate about the holder piece 2 until the vertical stopper 32 abuts against the portions of the holding projections 1, 1 projecting from the holder piece 2. The screw-less, rim rock-and-temple hinge structure facilitates the assembling and disassembling of eyeglasses, giving a neat shape to the eyeglasses.

**6 Claims, 3 Drawing Sheets**

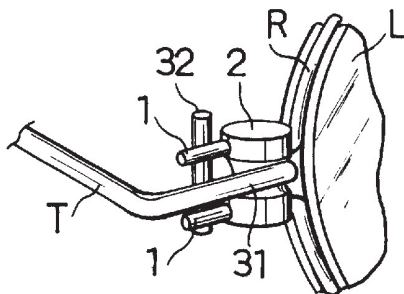
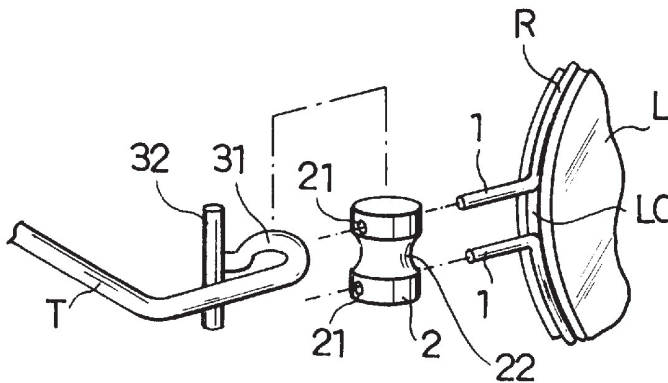

FIG. 1

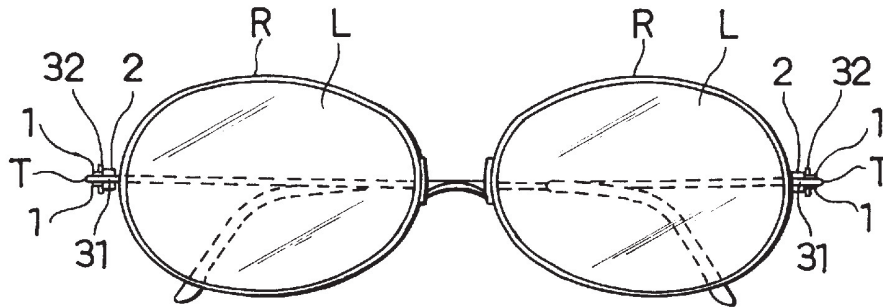

FIG. 2

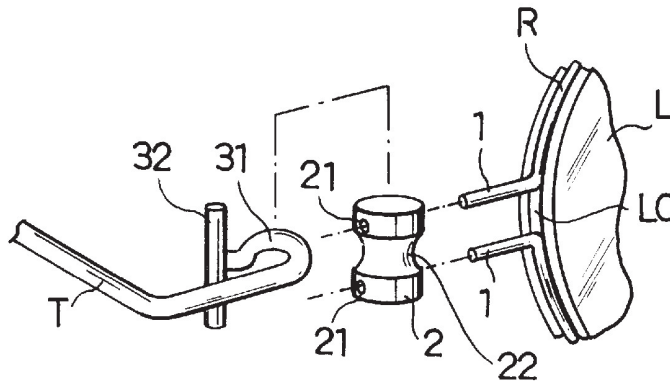

FIG. 3

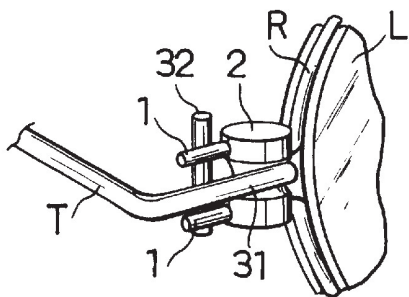

FIG. 4

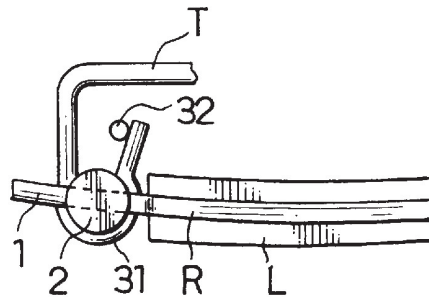

FIG. 5

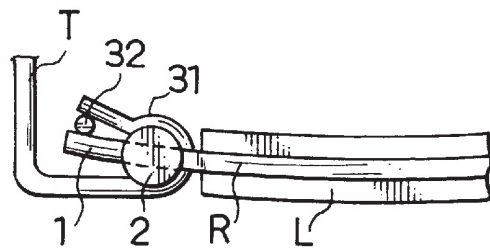

FIG. 6

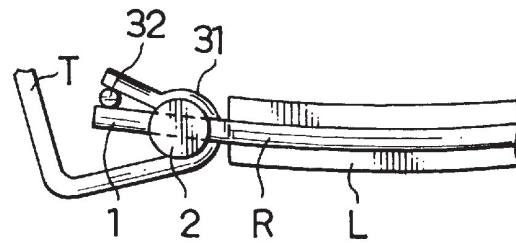

FIG. 7

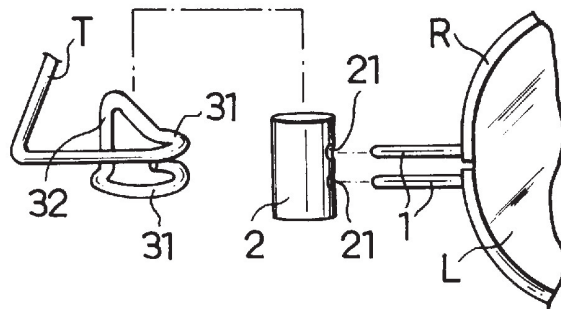

FIG. 8

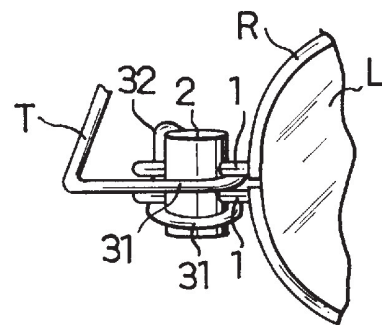

FIG. 9

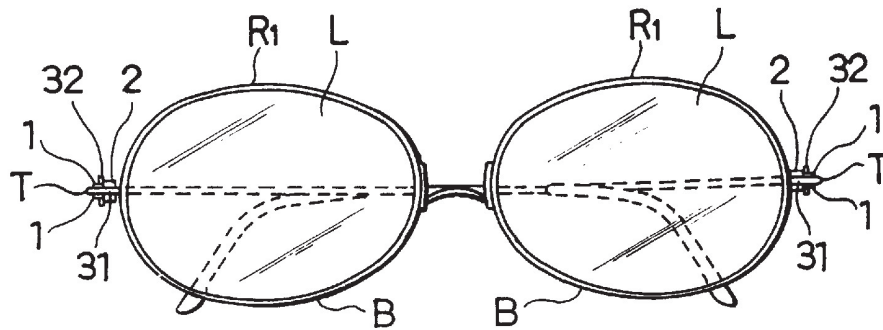

FIG. 10

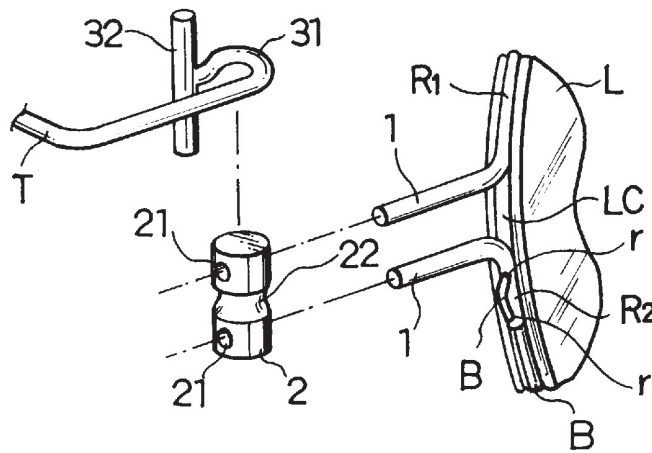
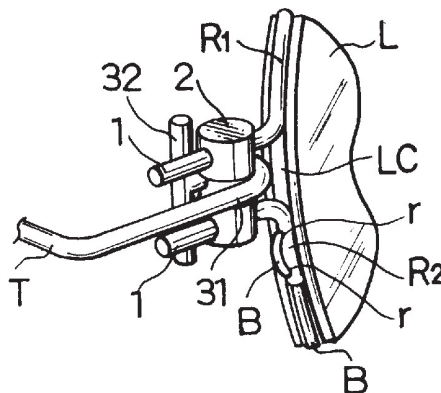

FIG. 11



## EYEGLASS FRAME ASSEMBLY HAVING SCREW-LESS HINGES

### BACKGROUND OF THE INVENTION

#### 1. Field of the Invention

The present invention relates generally to an eyeglass frame assembly, and particularly to an eyeglass frame assembly which is easy to be assembled, and is simple in structure and neat in appearance. Usually such an eyeglass frame assembly has rim lock-and-temple hinge means integrally formed therein.

#### 2. Description of Related Art

There has been an increasing demand for light eyeglass frames, not permitting their rims to cause any hindrance to the sight, expanding the field of sight, still assuring that comfortable feeling is given to persons wearing such eyeglasses. Thus, the rim and temple of the frames has been reduced toward a possible minimum thickness. As a matter of fact, however, there is a certain limit to reduction in slimming the frame structure. Specifically as the rim and temple is reduced in size, associated rim-locking pieces and hinges need to be reduced in size because otherwise, they would give an awkward appearance to the eyeglasses, but such parts are very difficult to reduce their sizes; their sizes have reached to practically possible minimum.

As is well known, a conventional rim locking part uses very small-sized screws to close and fix the opposite ends of the open-loop rim. Also, a conventional hinge uses a screw as a pivot. Therefore, reduction of rim locking parts and hinges cannot be attained without reducing the size of associated screws. Such screws, however, are reduced to practically possible minimum, and further reduction would be next to impossible. Also, disadvantageously use of such minimum screws makes it difficult to assemble associated parts, thus not facilitating the changing of lenses. Still disadvantageously such minimum screws are liable to loosen. Further reduction of such parts even if possible, would be undesirable from these points of view.

### SUMMARY OF THE INVENTION

In view of the above one object of the present invention is to provide an eyeglass frame assembly having screw-less hinges, more particularly screw-less, rim lock-and-temple hinge units, thereby providing a pleasing neat appearance for the eyeglasses.

To attain this object an eyeglass frame assembly having screw-less hinges comprising a front comprising two rims each embracing a lens and a bridge connecting these rims by their inner sides; and a pair of temples each rotatably connected to the outer side of each rim, is improved according to the present invention in that: each of said rims is an open-loop metal wire having two parallel holding projections formed at its opposite open ends; each of said temples has a major arc-like hook formed at its end, said hook having a vertical stopper at its end; and said eyeglass frame assembly includes two holder pieces, each having two holes to accommodate said two parallel holding projections, allowing said major arc-like hook to embrace each holder piece, thereby permitting said temples to rotate about said holder pieces until said holding projections abut against the vertical stoppers of the major arc-like hooks.

The present invention can be applied to suspender-type eyeglasses which has a pair of lenses suspended by strings such as nylon threads. Specifically, each rim comprises an upper rim half of metal wire and a lower rim half, which is

in the form of string for suspending the lens from the upper rim half. The upper rim half has a holding projection formed at its outer end, and the suspending string has a holding projection bound to its outer end. Each temple has a major arc-like hook formed at its end, and the hook has a vertical stopper integrally connected to its end. The frame assembly includes two holder pieces, each having two holes to accommodate the holding projections of the upper and lower rim halves, allowing the major arc-like hook to embrace each holder piece, thereby permitting the temples to rotate about the holder pieces until the holding projections abut against the vertical stoppers of the major arc-like hooks.

Each holder piece may have an annular groove made on its circumference for permitting the major arc-like hook to be press-fitted therein.

The holder pieces may be made of a synthetic resin material, and two parallel holding projections may be detachably inserted into the holes of each holder piece.

Other objects and advantages of the present invention will be understood from the following description of eyeglass frame assembly according to preferred embodiments of the present invention, which are shown in accompanying drawings.

### BRIEF DESCRIPTION OF THE DRAWINGS

FIG. 1 is a front view of an eyeglasses whose frame assembly has screw-less, rim lock-and-temple hinge means according to a first embodiment of the present invention;

FIG. 2 is an exploded, perspective view of the rim lock-and-temple hinge means;

FIG. 3 is a perspective view of the rim lock-and-temple hinge means;

FIG. 4 is a plane view of the rim lock-and-temple hinge means in the temple-folding position;

FIG. 5 is a similar plane view of the rim lock-and-temple hinge means in the temple-opening position, in which the temple is opened perpendicular to the front of the frame;

FIG. 6 is a similar plane view of the rim lock-and-temple hinge means, showing that the temple is opened beyond the normal temple-opening position;

FIG. 7 is an exploded, perspective view of a rim lock-and-temple hinge means according to a second embodiment of the present invention;

FIG. 8 is a perspective view of the rim lock-and-temple hinge means;

FIG. 9 is a front view of a suspender-type eyeglasses whose frame assembly uses rim lock-and-temple hinge means according to a third embodiment of the present invention;

FIG. 10 is an exploded, perspective view of the rim lock-and-temple hinge means; and

FIG. 11 is a perspective view of the rim lock-and-temple hinge means.

### DESCRIPTION OF THE PREFERRED EMBODIMENTS

The first, second and third embodiments of the present invention are described below with reference to these drawings.

FIGS. 1 to 6 show the first embodiment of the present invention;

FIGS. 7 and 8 show the second embodiment; and FIGS. 9 to 11 show the third embodiment.



# Explore Litigation Insights

Docket Alarm provides insights to develop a more informed litigation strategy and the peace of mind of knowing you're on top of things.

## Real-Time Litigation Alerts



Keep your litigation team up-to-date with **real-time alerts** and advanced team management tools built for the enterprise, all while greatly reducing PACER spend.

Our comprehensive service means we can handle Federal, State, and Administrative courts across the country.

## Advanced Docket Research



With over 230 million records, Docket Alarm's cloud-native docket research platform finds what other services can't. Coverage includes Federal, State, plus PTAB, TTAB, ITC and NLRB decisions, all in one place.

Identify arguments that have been successful in the past with full text, pinpoint searching. Link to case law cited within any court document via Fastcase.

## Analytics At Your Fingertips



Learn what happened the last time a particular judge, opposing counsel or company faced cases similar to yours.

Advanced out-of-the-box PTAB and TTAB analytics are always at your fingertips.

## API

Docket Alarm offers a powerful API (application programming interface) to developers that want to integrate case filings into their apps.

## LAW FIRMS

Build custom dashboards for your attorneys and clients with live data direct from the court.

Automate many repetitive legal tasks like conflict checks, document management, and marketing.

## FINANCIAL INSTITUTIONS

Litigation and bankruptcy checks for companies and debtors.

## E-DISCOVERY AND LEGAL VENDORS

Sync your system to PACER to automate legal marketing.