

FEATURES

Complete Acceleration Measurement System on a Single Monolithic IC
Full-Scale Measurement Range: ± 50 g
Self-Test on Digital Command
+5 V Single Supply Operation
Sensitivity Precalibrated to 19 mV/g
Internal Buffer Amplifier for User Adjustable Sensitivity and Zero-g Level
Frequency Response: DC to 10 kHz
Post Filtering with External Passive Components
High Shock Survival: >2000 g Unpowered
Other Versions Available: ADXL05 (± 5 g)

GENERAL DESCRIPTION

The ADXL50 is a complete acceleration measurement system on a single monolithic IC. Three external capacitors and a +5 volt power supply are all that is required to measure accelerations up to ± 50 g. Device sensitivity is factory trimmed to 19 mV/g, resulting in a full-scale output swing of ± 0.95 volts for a ± 50 g applied acceleration. Its zero g output level is +1.8 volts.

A TTL compatible self-test function can electrostatically deflect the sensor beam at any time to verify device functionality.

For convenience, the ADXL50 has an internal buffer amplifier with a full 0.25 V to 4.75 V output range. This may be used to set the zero-g level and change the output sensitivity by using external resistors. External capacitors may be added to the resistor network to provide 1 or 2 poles of filtering. No external active components are required to interface directly to most analog-to-digital converters (ADCs) or microcontrollers.

The ADXL50 uses a capacitive measurement method. The analog output voltage is directly proportional to acceleration, and is fully scaled, referenced and temperature compensated, resulting in high accuracy and linearity over a wide temperature range. Internal circuitry implements a forced-balance control loop that improves accuracy by compensating for any mechanical sensor variations.

The ADXL50 is powered from a standard +5 V supply and is robust for use in harsh industrial and automotive environments and will survive shocks of more than 2000 g unpowered.

The ADXL50 is available in a hermetic 10-pin TO-100 metal can, specified over the 0°C to +70°C commercial, and -40°C to +85°C industrial temperature ranges. Contact factory for availability of devices specified for operation over the -40°C to +105°C automotive temperature range.

FUNCTIONAL BLOCK DIAGRAM

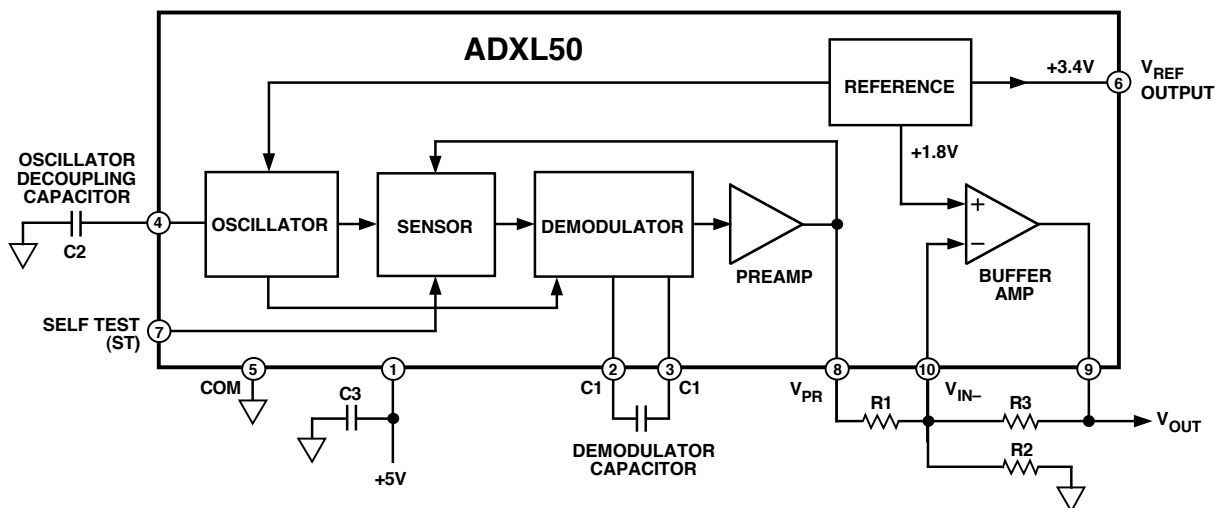

*Patents pending.

REV. B

Information furnished by Analog Devices is believed to be accurate and reliable. However, no responsibility is assumed by Analog Devices for its use, nor for any infringements of patents or other rights of third parties which may result from its use. No license is granted by implication or otherwise under any patent or patent rights of Analog Devices.

© Analog Devices, Inc., 1996

One Technology Way, P.O. Box 9106, Norwood, MA 02062-9106, U.S.A.
 Tel: 617/329-4700 Fax: 617/326-8703

ADXL50—SPECIFICATIONS (T_A = T_{MIN} to T_{MAX}, T_A = +25°C for J Grade Only, V_S = +5 V, @ Acceleration = 0 g, unless otherwise noted)

Parameter	Conditions	ADXL50J/A			Units
		Min	Typ	Max	
SENSOR INPUT					
Measurement Range	Guaranteed Full Scale	-50		+50	g
Nonlinearity	Best Fit Straight Line, 50 g FS		0.2		% of FS
Alignment Error ¹			±1		Degrees
Transverse Sensitivity ²			±2		%
SENSITIVITY					
Initial Sensitivity at V _{PR}	+25°C	16.1	19.0	21.9	mV/g
Temperature Drift ³			0.75/1.0		% of Reading
ZERO g BIAS LEVEL					
Initial Offset	at V _{PR}	1.55/1.60	1.80	2.05/2.00	V
vs. Temperature ³			±15/35		mV
vs. Supply	V _S = 4.75 V to 5.25 V		10	32	mV/V
NOISE PERFORMANCE					
Voltage Noise Density	at V _{PR} BW = 10 Hz to 1 kHz		6.6	12	mg/√Hz
Noise in 100 Hz Bandwidth			66		mg rms
Noise in 10 Hz Bandwidth			20		mg rms
FREQUENCY RESPONSE					
3 dB Bandwidth ⁴	C1 = 0.022 μF (See Figure 22)	800	1300		Hz
3 dB Bandwidth ⁴	C1 = 0.0068 μF		10		kHz
Sensor Resonant Frequency			24		kHz
SELF TEST INPUT					
Output Change at V _{PR} ⁵	ST Pin from Logic "0" to "1"	-0.85	-1.00	-1.15	V
Logic "1" Voltage		2.0			V
Logic "0" Voltage				0.8	V
Input Resistance	To Common		50		kΩ
+3.4 V REFERENCE					
Output Voltage		3.350	3.400	3.450	V
Output Temperature Drift ³			±10		mV
Power Supply Rejection	DC, V _S = +4.75 V to +5.25 V		1	10	mV/V
Output Current	Sourcing	500			μA
PREAMPLIFIER OUTPUT					
Voltage Swing		0.25		V _S - 1.4	V
Current Output	Source or Sink	30	80		μA
Capacitive Load Drive			100		pF
BUFFER AMPLIFIER					
Input Offset Voltage ⁶	Delta from Nominal 1.800 V		±10	±25	mV
Input Bias Current			5	20	nA
Open-Loop Gain	DC		80		dB
Unity Gain Bandwidth			200		kHz
Output Voltage Swing	I _{OUT} = ±100 μA	0.25		V _S - 0.25	V
Capacitive Load Drive		1000			pF
Power Supply Rejection	DC, V _S = +4.75 V to +5.25 V		1	10	mV/V
POWER SUPPLY					
Operating Voltage Range		4.75		5.25	V
Quiescent Supply Current			10	13	mA
TEMPERATURE RANGE					
Operating Range J		0		+70	°C
Specified Performance A		-40		+85	°C
Automotive Grade*		-40		+125	°C

NOTES

¹Alignment error is specified as the angle between the true and indicated axis of sensitivity, (see Figure 2).

²Transverse sensitivity is measured with an applied acceleration that is 90° from the indicated axis of sensitivity. Transverse sensitivity is specified as the percent of transverse acceleration that appears at the V_{PR} output. This is the algebraic sum of the alignment and the inherent sensor sensitivity errors, (see Figure 2).

³Specification refers to the maximum change in parameter from its initial at +25°C to its worst case value at T_{MIN} to T_{MAX}.

⁴Frequency at which response is 3 dB down from dc response assuming an exact C1 value is used. Maximum recommended BW is 10 kHz using a 0.007 μF capacitor, refer to Figure 22.

⁵Applying logic high to the self-test input has the effect of applying an acceleration of -52.6 g to the ADXL50.

⁶Input offset voltage is defined as the output voltage differential from 1.800 V when the amplifier is connected as a follower (i.e., Pins 9 and 10 tied together). The voltage at Pin 9 has a temperature drift proportional to that of the 3.4 V reference.

*Contact factory for availability of automotive grade devices.

All min and max specifications are guaranteed. Typical specifications are not tested or guaranteed. Specifications subject to change without notice.

ADXL50

ABSOLUTE MAXIMUM RATINGS*

Acceleration (Any Axis, Unpowered for 0.5 ms)	2000 g
Acceleration (Any Axis, Powered for 0.5 ms)	500 g
+V _S	-0.3 V to +7.0 V
Output Short Circuit Duration (V _{PR} , V _{OUT} , V _{REF} Terminals to Common)	Indefinite
Operating Temperature	-55°C to +125°C
Storage Temperature	-65°C to +150°C

*Stresses above those listed under “Absolute Maximum Ratings” may cause permanent damage to the device. This is a stress rating only; the functional operation of the device at these or any other conditions above those indicated in the operational sections of this specification is not implied. Exposure to absolute maximum rating conditions for extended periods may affect device reliability.

Package Characteristics

Package	θ _{JA}	θ _{JC}	Device Weight
10-Pin TO-100	130°C/W	30°C/W	5 Grams

ORDERING GUIDE

Model	Temperature Range
ADXL50JH	0°C to +70°C
ADXL50AH	-40°C to +85°C

CAUTION

ESD (electrostatic discharge) sensitive device. Electrostatic charges as high as 4000 V readily accumulate on the human body and test equipment and can discharge without detection. Although the ADXL50 features proprietary ESD protection circuitry, permanent damage may occur on devices subjected to high energy electrostatic discharges. Therefore, proper ESD precautions are recommended to avoid performance degradation or loss of functionality.



PIN DESCRIPTION

+5 V	The power supply input pin.
C2	Connection for an external bypass capacitor (nominally 0.022 μF) used to prevent oscillator switching noise from interfering with other ADXL50 circuitry. Please see the section on component selection.
C1	Connections for the demodulator capacitor, nominally 0.022 μF. See the section on component selection for application information.
COM	The power supply common (or “ground”) connection.
V _{REF}	Output of the internal 3.4 V voltage reference.
ST	The digital self-test input. It is both CMOS and TTL compatible.
V _{PR}	The ADXL50 preamplifier output providing an output voltage of 19 mV per g of acceleration.
V _{OUT}	Output of the uncommitted buffer amplifier.
V _{IN-}	The inverting input of the uncommitted buffer amplifier.

CONNECTION DIAGRAM

10-Header (TO-100)

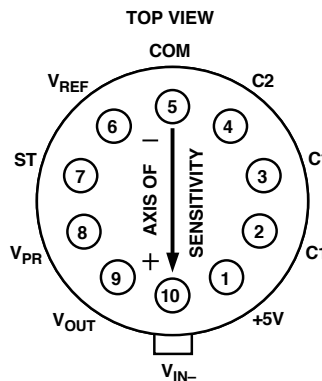

NOTES:

AXIS OF SENSITIVITY IS ALONG A LINE BETWEEN PIN 5 AND THE TAB.

THE CASE OF THE METAL CAN PACKAGE IS CONNECTED TO PIN 5 (COMMON).

ARROW INDICATES DIRECTION OF POSITIVE ACCELERATION ALONG AXIS OF SENSITIVITY.

ADXL50

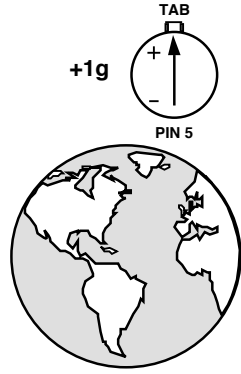

Figure 1. Output Polarity at V_{PR}

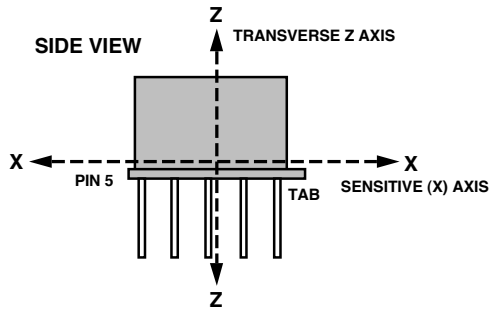

Figure 2a. Sensitive X and Transverse Z Axis

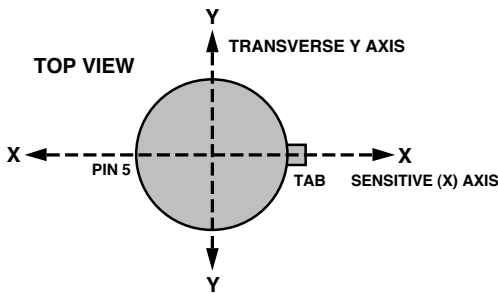

Figure 2b. Sensitive X and Transverse Y Axis

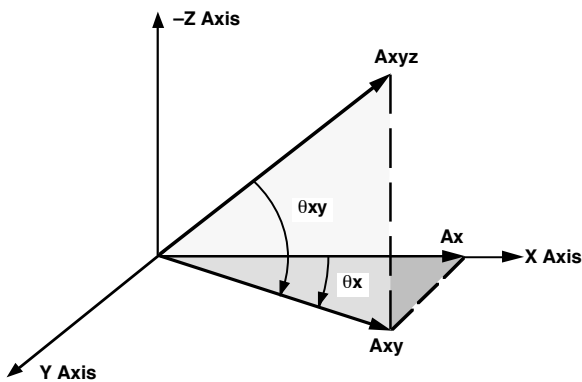

Figure 2c. A Vector Analysis of an Acceleration Acting Upon the ADXL50 in Three Dimensions

Polarity of the Acceleration Output

The polarity of the ADXL50 output is shown in the Figure 1. When oriented to the earth's gravity (and held in place), the ADXL50 will experience an acceleration of +1 g. This corresponds to a change of approximately +19 mV at the V_{PR} output pin. Note that the polarity will be reversed to a negative going signal at the buffer amplifier output V_{OUT} , due to its inverting configuration.

Mounting Considerations

There are three main causes of measurement error when using accelerometers. The first two are alignment and transverse sensitivity errors. The third source of error is due to resonances or vibrations of the sensor in its mounting fixture.

Errors Due to Misalignment

The ADXL50 is a sensor designed to measure accelerations that result from an applied force. Because these forces act on the sensor in a vector manner, the alignment of the sensor to the force to be measured may be critical.

The ADXL50 responds to the component of acceleration on its sensitive X axis. Figures 2a and 2b show the relationship between the sensitive "X" axis and the transverse "Z" and "Y" axes as they relate to the TO-100 package.

Figure 2c describes a three dimensional acceleration vector (A_{XYZ}) which might act on the sensor, where A_X is the component of interest. To determine A_X , first, the component of acceleration in the XY plane (A_{XY}) is found using the cosine law:

$$A_{XY} = A_{XYZ} (\cos\theta_{ZY}) \text{ then}$$

$$A_X = A_{XY} (\cos\theta_X)$$

$$\text{Therefore: Typical } V_{PR} = 19 \text{ mV/g } (A_{XYZ}) (\cos\theta_{ZY}) \cos\theta_X$$

Note that an ideal sensor will react to forces along or at angles to its sensitive axis but will reject signals from its various transverse axes, i.e., those exactly 90° from the sensitive "X" axis. But even an ideal sensor will produce output signals if the transverse signals are not exactly 90° to the sensitive axis. An acceleration that is acting on the sensor from a direction different from the sensitive axis will show up at the ADXL50 output at a reduced amplitude.

Table I. Ideal Output Signals for Off Axis Applied Accelerations Disregarding Device Alignment and Transverse Sensitivity Errors

θ_X	% of Signal Appearing at Output	Output in gs for a 50 g Applied Acceleration
0	100%	50 (On Axis)
1°	99.98%	49.99
2°	99.94%	49.97
3°	99.86%	49.93
5°	99.62%	49.81
10°	98.48%	49.24
30°	86.60%	43.30
45°	70.71%	35.36
60°	50.00%	25.00
80°	17.36%	8.68
85°	8.72%	4.36
87°	5.25%	2.63
88°	3.49%	1.75
89°	1.7%	0.85

Table I shows the percentage signals resulting from various θ_x angles. Note that small errors in alignment have a negligible effect on the output signal. A 1° error will only cause a 0.02% error in the signal. Note, however, that a signal coming 1° off of the transverse axis (i.e., 89° off the sensitive axis) will still contribute 1.7% of its signal to the output. Thus large transverse signals could cause output signals as large as the signals of interest.

Table I may also be used to approximate the effect of the ADXL50's internal errors due to misalignment of the die to the package. For example: a 1 degree sensor alignment error will allow 1.7% of a transverse signal to appear at the output. In a nonideal sensor, transverse sensitivity may also occur due to inherent sensor properties. That is, if the sensor physically moves due to a force applied exactly 90° to its sensitive axis, then this might be detected as an output signal, whereas an ideal sensor would reject such signals. In every day use, alignment errors may cause a small output peak with accelerations applied close to the sensitive axis but the largest errors are normally due to large accelerations applied close to the transverse axis.

Errors Due to Mounting Fixture Resonances

A common source of error in acceleration sensing is resonance of the mounting fixture. For example, the circuit board that the ADXL50 mounts to may have resonant frequencies in the same range as the signals of interest. This could cause the signals measured to be larger than they really are. A common solution to this problem is to dampen these resonances by mounting the ADXL50 near a mounting post or by adding extra screws to hold the board more securely in place.

When testing the accelerometer in your end application, it is recommended that you test the application at a variety of frequencies in order to ensure that no major resonance problems exist.

GLOSSARY OF TERMS

Acceleration: Change in velocity per unit time.

Acceleration Vector: Vector describing the net acceleration acting upon the ADXL50 (A_{XYZ}).

g: A unit of acceleration equal to the average force of gravity occurring at the earth's surface. A g is approximately equal to 32.17 feet/s², or 9.807 meters/s².

Nonlinearity: The maximum deviation of the ADXL50 output voltage from a best fit straight line fitted to a plot of acceleration vs. output voltage, calculated as a % of the full-scale output voltage (@ 50 g).

Resonant Frequency: The natural frequency of vibration of the ADXL50 sensor's central plate (or "beam"). At its resonant frequency of 24 kHz, the ADXL50's moving center plate has a peak in its frequency response with a Q of 3 or 4.

Sensitivity: The output voltage change per g unit of acceleration applied, specified at the V_{PR} pin in mV/g.

Sensitive Axis (X): The most sensitive axis of the accelerometer sensor. Defined by a line drawn between the package tab and Pin 5 in the plane of the pin circle. See Figures 2a and 2b.

Sensor Alignment Error: Misalignment between the ADXL50's on-chip sensor and the package axis, defined by Pin 5 and the package tab.

Total Alignment Error: Net misalignment of the ADXL50's on-chip sensor and the measurement axis of the application. This error includes errors due to sensor die alignment to the package, and any misalignment due to installation of the sensor package in a circuit board or module.

Transverse Acceleration: Any acceleration applied 90° to the axis of sensitivity.

Transverse Sensitivity Error: The percent of a transverse acceleration that appears at the V_{PR} output. For example, if the transverse sensitivity is 1%, then a +10 g transverse acceleration will cause a 0.1 g signal to appear at V_{PR} (1% of 10 g). Transverse sensitivity can result from a sensitivity of the sensor to transverse forces or from misalignment of the internal sensor to its package.

Transverse Y Axis: The axis perpendicular (90°) to the package axis of sensitivity in the plane of the package pin circle. See Figure 2.

Transverse Z Axis: The axis perpendicular (90°) to both the package axis of sensitivity and the plane of the package pin circle. See Figure 2.

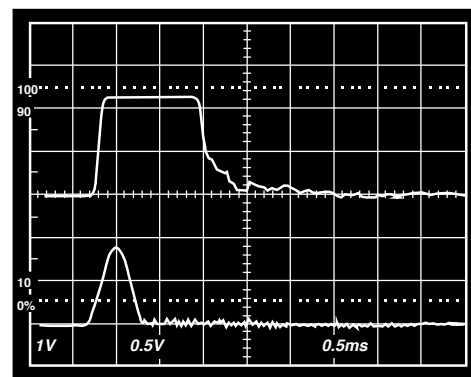

Figure 3. 500 g Shock Overload Recovery. Top Trace: ADXL50 Output. Bottom Trace: Reference Accelerometer Output

Explore Litigation Insights

Docket Alarm provides insights to develop a more informed litigation strategy and the peace of mind of knowing you're on top of things.

Real-Time Litigation Alerts



Keep your litigation team up-to-date with **real-time alerts** and advanced team management tools built for the enterprise, all while greatly reducing PACER spend.

Our comprehensive service means we can handle Federal, State, and Administrative courts across the country.

Advanced Docket Research



With over 230 million records, Docket Alarm's cloud-native docket research platform finds what other services can't. Coverage includes Federal, State, plus PTAB, TTAB, ITC and NLRB decisions, all in one place.

Identify arguments that have been successful in the past with full text, pinpoint searching. Link to case law cited within any court document via Fastcase.

Analytics At Your Fingertips



Learn what happened the last time a particular judge, opposing counsel or company faced cases similar to yours.

Advanced out-of-the-box PTAB and TTAB analytics are always at your fingertips.

API

Docket Alarm offers a powerful API (application programming interface) to developers that want to integrate case filings into their apps.

LAW FIRMS

Build custom dashboards for your attorneys and clients with live data direct from the court.

Automate many repetitive legal tasks like conflict checks, document management, and marketing.

FINANCIAL INSTITUTIONS

Litigation and bankruptcy checks for companies and debtors.

E-DISCOVERY AND LEGAL VENDORS

Sync your system to PACER to automate legal marketing.