

⑫ **EUROPEAN PATENT SPECIFICATION**

- ④⑤ Date of publication of patent specification: **13.11.85**      ⑤① Int. Cl.<sup>4</sup>: **G 02 B 25/00, G 02 C 7/14**  
②① Application number: **81303549.0**  
②② Date of filing: **04.08.81**

⑤④ **Vision enhancing system.**

③⑩ Priority: **05.08.80 US 175412**

④③ Date of publication of application:  
**10.02.82 Bulletin 82/06**

④⑤ Publication of the grant of the patent:  
**13.11.85 Bulletin 85/46**

⑧④ Designated Contracting States:  
**AT BE CH DE FR GB IT LI LU NL SE**

⑤⑥ References cited:  
**CH-A- 579 378**  
**FR-A-2 172 892**  
**US-A-2 226 941**  
**US-A-3 273 456**  
**US-A-3 893 135**

⑦③ Proprietor: **RESEARCH TRIANGLE INSTITUTE**  
**Post Office Box 12194 Research Triangle Park**  
**Durham North Carolina (US)**

⑦② Inventor: **Beadles, Robert L.**  
**5435 Lake View Drive**  
**Durham Carolina 27712 (US)**  
Inventor: **Pekar, Jaroslaw NMI**  
**Post Office Box 625**  
**Chapel Hill North Carolina 27514 (US)**

⑦④ Representative: **Shaw, Laurence**  
**George House George Road**  
**Edgbaston Birmingham B15 1PG (GB)**

**EP 0 045 656 B1**

Note: Within nine months from the publication of the mention of the grant of the European patent, any person may give notice to the European Patent Office of opposition to the European patent granted. Notice of opposition shall be filed in a written reasoned statement. It shall not be deemed to have been filed until the opposition fee has been paid. (Art. 99(1) European patent convention).

Courier Press, Leamington Spa, England.

## Description

The invention relates to a vision enhancing system that provides magnification capabilities while, presenting an aesthetically pleasing appearance. Although the invention has other applications, it is primarily to enable low-vision persons to read fine print material, to see blackboard work in educational facilities, and, in general, to provide acceptable distance vision.

There are a large number of low-vision persons, i.e. those having about 20/200 vision. The visual acuity of such individuals is not correctable to better than 20/50 with single-lens systems such as conventional eyeglasses or contact lenses, correction to 20/100 being more typical. Various attempts to enhance the visual acuity of such individuals to 20/20 have resulted in the construction of unsightly and unwieldy optical structures extending forward from the individual's eyes. While such prior attempts were optically effective, the forward extension of the optics provided an awkward impediment to head movement and the weight, being well forward of the nose support, created an unnatural muscular strain.

It is an object of the invention to provide improved apparatus for the purpose specified. Apparatus of the invention takes advantage of the distance between the wearer's temples to provide the major optical path, instead of extending it forward from the eyes of the user. By making the optical path parallel to a line between the wearer's temples, it is possible to obtain sufficient magnification while minimizing interference with the user's normal activities and the cosmetic drawbacks normally associated with vision-enhancing systems.

A sight facilitating apparatus comprising an elongate casing containing a lens system and a mounting means for mounting the casing on a wearer's head so that the direction of elongation of the casing extends substantially horizontally between the wearer's temples, according to the invention, is characterised in that a single prismatic telescopic system including an objective, an ocular and inverting and reversing optical means is provided in the housing, that the objective is mounted within the casing so that the majority of the focal length of the objective extends substantially parallel to the longitudinal axis of the casing, and in that a single light exit is located adjacent an eye of the wearer.

Means are preferably provided for adjusting the focus of the lens system from outside the casing, and means are provided for mounting the objective within the casing so that the majority of the focal length of the objective lies within, and parallel to the direction of elongation of the casing. Means are provided for mounting the casing on a wearer's head so that the direction of elongation of the casing extends substantially horizontally across the wearer's forehead with the light exit at the wearer's eye. The mounting means preferably comprises an eyeglass frame

including a support, nose piece and earpieces, with eyeglass lenses disposed in the frame support. Means are provided for mounting the casing on top of the frame support above the lenses and between the ear pieces, with the light entry and eyepiece disposed so that by tilting his/her eyes upward, the wearer can look through the light exit. The casing may be sealed so that dirt, moisture, and the like cannot enter the casing and affect the lens system, and the lens system itself may take a variety of forms depending upon the particular use.

Apparatus of the invention is of low weight, about 56 grams or less, is safe and rugged, yet is capable of correcting a low-vision person's sight to 20/20, or close to it. Magnifications on the order of 4x to 8x are readily provided. Utilizing the system according to the present invention, a low-vision person is not immediately identified as such, and thus the system according to the present invention may be utilized without undesirably increasing the self-consciousness of the wearer.

A typical low-vision person has one dominant eye, and the present invention provides a monocular system for aiding the vision of the dominant eye of the low-vision wearer. However, the invention also has applicability to other than low-vision systems. For instance the apparatus may be modified for use in covert surveillance, spectating at sports and cultural events, etc.

### Brief Description of the Drawings

FIGURE 1 is a perspective view illustrating apparatus according to the present invention in use on a wearer;

FIGURE 2 is a perspective view of apparatus similar to that of FIGURE 1 shown in use with a different style of eyeglass frame;

FIGURE 3 is a bottom view of the lens system casing of FIGURE 1 with the bottom plate removed;

FIGURE 4 is a modification of the optical components of the apparatus of FIGURE 3;

FIGURE 5 is a view partly in cross-section and partly in elevation of another embodiment illustrating a different lens system;

FIGURE 6 is a side schematic view illustrating a modified manner of interengagement between conventional eyeglass components and a lens system casing according to the invention.

### Detailed Description of the Drawings

Exemplary apparatus according to the present invention is illustrated generally at 10 in the drawings. The major element of the apparatus comprises a casing 12, which preferably is elongated in dimension L, and may be a rectangular parallelepiped. The casing may be made of any suitable material, preferably a lightweight material such as aluminum. Means are provided defining a light entry 13 into the casing, and means are provided defining a light exit 14 (see FIGURE 3) from the casing disposed on an opposite portion thereof as the light entry. The casing

12 dimension of elongation L preferably is equal to or less than the distance between a wearer's ears (see FIGURE 1), and the casing 12 has shortened second and third dimensions H, W compared to the dimension of elongation L.

The apparatus 10 (see FIGURE 3) further comprises a prismatic telescopic lens system, including an objective 16 and an ocular 17 mounted within the casing 12. The objective 16 and the ocular 17 may comprise any suitable lenses. For instance, the objective 16 may comprise an acromat with a focal length of about 66 mm. The ocular 17 preferably includes a field lens 18 and an eye lens 19, and may be of symmetrical Ramsden type, with a focal length of 12 mm. Inverting and reversing optical means (such as a plurality of prisms as described below with respect to particular embodiments of the lens system) are also provided to direct the light through the lens system and provide an erect image to the eye.

Means are also provided for adjusting the focus of the lens system. Such means may include an actuator 22 extending exteriorly of the casing 12 (see FIGURES 1 and 2) mounted on the "top" surface of the casing 12. In the embodiment illustrated in FIGURES 1 through 4, the actuator 22 is connected to a shaft 23 which extends through a seal (not shown) into the interior of the casing 12, and having a peripheral disc 24 mounted for rotation therewith. A take-up cable 25 is mounted to the circumference of the peripheral disc 24, and frictional engagement between the circumference of the disc 24 and a stationary friction member 27 within the casing 12 maintains the shaft 23 in the position to which it has been rotated. The cable is connected at the end 29 thereof to a block 30 mounted for linear slidable movement within the casing 12 in dimension L, and guided in that path of movement by the walls of the casing 12. A spring 31 is connected at one end 32 thereof to the block 30, and at the other end 33 thereof to the casing 12 to provide spring pressure tending to move the block 30 to the right in FIGURE 3.

In all illustrated embodiments, the objective 16 is mounted by appropriate means within the casing 12 so that the majority of the focal length extends parallel to the dimension L (direction of elongation of the casing 12).

Means are provided for mounting the casing 12 on a wearer's head (see FIGURE 1) so that the direction of elongation L extends substantially horizontally between the wearer's temples, with the light exit 14 adjacent the wearer's eye. Such mounting means preferably, especially in low-vision applications of the invention, takes the form of a conventional eyeglass frame including a support 40, nosepiece 41, ear pieces 43, 44, and eyeglass lenses 45 mounted by the support 40 (see FIGURES 1 and 2 in particular). Any suitable eyeglass frame style may be provided; alternatively, the casing 12 may comprise an integral part of the top portion of the eyeglass frame. For low-vision systems, the eyeglass frame illustrated in FIGURE 1 is desirable since the height of the

lenses 45 is relatively small, allowing the casing 12 to be mounted on top of the support 40 and readily be utilized by the wearer tilting his eyes with respect to his head, an angle  $\alpha$  (see FIGURE 1), much in the same manner that conventional bifocals are utilized.

Preferably the height H of the casing 12 is less than the height of the eyeglass lenses 45, and the width W also is relatively small, preferably small enough so that the casing 12 does not extend in front of the eyeglass lenses 45 any significant extent (see FIGURES 1 and 2).

Typically, the casing 12, with lens system disposed therein, according to the present invention would have a weight of about 56 g or less (e.g., 42 g), and having the relative dimensions with respect to the glass frame 40 illustrated in FIGURES 1 and 2 would not be uncomfortable to wear, and would be aesthetically pleasing, being little more obtrusive than conventional eyeglass frames. Mounting of the casing 12 to the frame support 40 could be accomplished utilizing any suitable conventional fastening means, such as brackets and screws, adhesives, clips, and the like; or (as illustrated in FIGURE 7) the casing 12 may actually be integral with and form a portion of the frame support 40. Mounted as illustrated in FIGURE 1, the wearer could tilt his head downwardly at an angle  $\alpha$  ( $\alpha$  preferably being about  $10^\circ$ ) from a position looking through the eyeglass lenses 45, and would then be able to look through the light exit 14 of the casing 12. The embodiment illustrated in FIGURES 1 through 4 is for a right-eye dominant low-vision person; the construction of a similar structure for a left-eye dominant low-vision person is readily apparent, being a mirror image of the structure illustrated in FIGURES 1 through 4.

The construction according to the present invention is simple and rugged, and because of the construction thereof the casing 12 may be readily sealed so that dirt, moisture, and the like cannot enter the casing and adversely affect the lens system. As illustrated in the drawings, normally the focus adjustment actuator 22 extending outwardly from the casing 12 will be adjacent the light exit 14 (that is associated with the lens 45 corresponding to the dominant eye of the wearer).

A variety of accommodations may be made in the construction of the frame support 40 and the eyeglasses 45 if the eyeglasses are constructed with the casing 12 in mind (although the casing 12 may be readily retrofitted to conventional eyeglasses). For instance, as illustrated in FIGURE 7, the eyeglass lenses 45' may be shaped on the upper portions 47 thereof to receive the bottom and front wall of the casing 12, which is integral with frame 40, to help positively locate it, and to decrease the effective height H of the casing 12 above the eyeglasses. Further similar accommodations can be made in the frame 40, with the result that a frame with the casing 12 would have dimensions corresponding to those of conventional eyeglasses.

A variety of components may be utilized in the lens system along with the objective 16 and ocular 17 in order to obtain the desired results. Each system will be described in the optical path order from light entry to light exit:

In the embodiment illustrated in FIGURE 3, the first light-redirecting optical element comprises an Amici prism 50, then the objective 16, then a pentaprism 51, and then the ocular 17. The ocular 17 is constructed and positioned so that the eye lens 19 extends outwardly from the casing 12.

In the embodiment illustrated in FIGURE 4, a flat glass window 52 seals the light entry 13, and instead of the Amici prism 50, a mirror 53 is provided for redirecting the incident light beam so that it exits first optical element 53 in dimension L. The objective 16 is next, and then a roof-pentaprism 54 is provided, and finally the ocular 17.

In the embodiment illustrated in FIGURE 5, the ocular is fully recessed, the eye lens 19 being flush with the casing 12. In the embodiment of FIGURE 5, the first optical element comprises roof-pentaprism 56; objective 16, the field lens 18 of the ocular 17, a right-angle prism 58, and the eye lens 19 of the ocular. In this embodiment, a slide pin 59 is shown schematically for adjusting the position of the objective 16 in dimension L, a frictional engagement being provided between the slide pin 59 where it extends in a sealed manner through the upper wall of the casing 12.

Also in FIGURE 5, the casing 12 is shown having a modular construction. The modular construction of the casing allows the ready fitting of the apparatus 10 to individuals merely by attaching modular components together. For instance in FIGURE 5, the casing 12 is shown as including a central modular component 60, and side components 61, 62, with demarcation lines 63, 64, respectively, being provided between the center 60 and side 61 and center 60 and side 62 modules. Different side components 61 may be provided with the eye lens 19 positioned with a particular spacing with respect to the demarcation line 63 to adjust for the particular spacing of the proposed wearer's eyes, and similarly the length of the component 62 may vary depending upon the desired distance between the ear pieces 43, 44. The modular components may be connected together in any suitable manner, such as with snap connections, adhesive, or the like, and sealing material may be provided at the interfaces 63, 64, if desired.

All of the various structures of the apparatus may take a wide variety of forms. For instance, the means for mounting the casing 12 on the wearer's head could comprise a helmet, or comprise clips for clipping onto conventional glasses, or could comprise a holder for bringing the operative components directly into operative relationship with the wearer's eyes (e.g., for binocular sports glasses or the like). Further, the eyeglass lenses may be tinted, ground off, or the like to hide the casing 12 completely or to any desirable extent. Adjustment of the focus of the lens system may

be by a sonar system, or other suitable means, and various accessory lenses, mirrors, or the like may be associated with the light entrance 13. For instance, various sliding or pivotal structures such as zoom lenses, mirrors, correcting lenses, tinted transparent plates, or the like may be mounted on casing 12 for movement into and out of operative relationship with the light entry 13. Any number of such structures could be provided depending upon the particular use for the apparatus.

To assemble apparatus of the invention, the various optical components of the lens system are mounted in the casing 12 as illustrated in FIGURE 3 and the casing bottom is closed. The casing 12 is then placed on top of a frame support 40 of a conventional pair of eyeglasses, for a right-eye dominant low-vision person, such as by utilizing screws and brackets, to provide the structure illustrated in FIGURE 1. The ear pieces 43, 44 are then placed on the wearer's ears in a conventional manner, and the wearer can look through the conventional eyeglass lenses 45.

When it is desired to properly view an object in the distance, the wearer merely tilts his head downwards or lifts his eyes with respect to his head an angle  $\alpha$ , and then the wearer may look through the ocular 17 at the light exit 14 adjacent his dominant right eye. By rotating actuator 22, the position of the objective 16 in dimension L is adjusted, thereby providing focusing on the object viewed. Light entering through light entry 13 passes through Amici prism 50, then through objective 16, through pentaprism 51, and then through ocular 17, providing an upright real image of the object being viewed.

It will thus be seen that according to the present invention a vision enhancing system has been provided which makes maximum obtrusiveness and minimum discomfort. For low-vision individuals, utilizing the present invention is possible to correct 20/200 vision to about 20/20 so that the individual can read fine print, do blackboard work in conventional educational institutions, and the like. Yet the apparatus according to the invention does not clearly denote the wearer to be a low-vision person, and has satisfactory aesthetic appeal.

#### Claims

1. A sight facilitating apparatus comprising an elongate casing (12) containing a lens system and a mounting means (43, 44) for mounting the casing (12) on a wearer's head so that the direction of elongation of the casing (12) extends substantially horizontally between the wearer's temples characterised in that a single prismatic telescopic system including an objective (16), an ocular (17) and inverting and reversing optical means (50, 51; 52, 53; 56, 58) is provided in the housing, that the objective (16) is mounted within the casing so that the majority of the focal length of the objective (16) extends substantially parallel

to the longitudinal axis of the casing, and in that a single light exit (14) is located adjacent an eye of the wearer.

2. Apparatus according to Claim 1 characterised in that adjusting means (22) accessible from outside the casing (12) are present for adjusting the focus of the lens system.

3. Apparatus according to Claim 2 characterised in that the adjusting means comprises a rotary actuator (22) extending into the casing (12) and connected to a block (30) carrying the objective (16), rotation of the actuator (22) being arranged to move the objective (16) longitudinally of the casing (12).

4. Apparatus according to Claim 1, 2 or 3 characterised in that the mounting means comprises an eyeglass or spectacle frame (40) and the casing (12) is mounted or incorporated in the top of the frame (40) with the light entry (13) facing forward and the light exit (14) facing rearward with respect to the wearer's head.

5. Apparatus according to Claim 4 characterised in that the casing (12) is mounted on the frame (40) such that the wearer may see through the light exit (14) by tilting his eye upwards through an angle of about 10°.

6. Apparatus according to Claim 4 or 5 characterised in that the width of the casing (12) is dimensioned such that the casing (12) does not project forwardly a significant distance from the eyeglass frame.

7. Apparatus according to any preceding Claim characterised in that the length (L) of the casing (12) is substantially equal to the distance between the wearer's temples, and in that the light entry (13) and the light exit (14) are spaced apart by a distance exceeding the distance between the pupils of the wearer's eyes.

8. Apparatus according to any preceding Claim characterised in that the lens system includes mounted in optical path order from the light entry (13) to the light exit (14), an Amici prism (50); and objective (16); a pentaprism (51); and an ocular (17).

#### Patentansprüche

1. Sehhilfsvorrichtung, bestehend aus einem länglichen, ein Linsensystem enthaltenden Gehäuse (12) und Halterungen (43, 44) zum Anbringen des Gehäuses (12) am Kopf eines Trägers, derart dass die Längsrichtung des Gehäuses (12) im wesentlichen waagrecht zwischen den Schläfen des Trägers verläuft, dadurch gekennzeichnet, dass ein einziges prismatisches Teleskopsystem mit einem Objektiv (16), einem Okular (17) sowie umkehrenden und aufrichtenden optischen Einrichtungen (50, 51; 52, 53; 56, 58) im Gehäuse vorgesehen ist, dass das Objektiv (16) innerhalb des Gehäuses so angeordnet ist, dass der Hauptanteil der Brennweite des Objektivs (16) im wesentlichen parallel zur Längsachse des Gehäuses verläuft und dass ein einziger Lichtaustritt (14) vor einem Auge des Trägers liegt.

2. Vorrichtung nach Anspruch 1, dadurch ge-

kennzeichnet, dass von ausserhalb des Gehäuses (12) zugängliche Einstellmittel (22) zur Scharfeinstellung des Linsensystems vorhanden sind.

3. Vorrichtung nach Anspruch 2 dadurch gekennzeichnet, dass die Einstellmittel ein drehbares Betätigungsorgan (22) umfassen, das sich in das Gehäuse (12) hinein erstreckt und mit einem das Objektiv (16) tragenden Block (30) verbunden ist, wobei eine Drehung des Betätigungsorgans (22) dazu dient, das Objektiv (16) entlang dem Gehäuse (12) zu bewegen.

4. Vorrichtung nach Anspruch 1, 2 oder 3, dadurch gekennzeichnet, dass die Halterungen aus einem Augenglasoder Brillenrahmen (40) bestehen und das Gehäuse (12) auf der Oberseite des Rahmens (40) angebracht oder darin eingebaut ist, wobei der Lichteintritt (13) gegenüber dem Kopf des Trägers nach vorne und der Lichtaustritt (14) nach hinten weist.

5. Vorrichtung nach Anspruch 4, dadurch gekennzeichnet, dass das Gehäuse (12) auf dem Rahmen (40) so gehalten ist, dass der Träger durch den Lichtaustritt (14) hindurchsehen kann, wenn er das Auge um einem Winkel von etwa 10° nach oben richtet.

6. Vorrichtung nach Anspruch 4 oder 5, dadurch gekennzeichnet, dass das Gehäuse (12) solche Breitenabmessungen aufweist, dass es nicht wesentlich über den Augenglasrahmen nach vorn vorsteht.

7. Vorrichtung nach einem der vorhergehenden Ansprüche, dadurch gekennzeichnet, dass die Länge (L) des Gehäuses (12) im wesentlichen gleich dem Abstand zwischen den Schläfen des Trägers ist und dass der Lichteintritt (13) und der Lichtaustritt (14) um einen Abstand auseinanderliegen, der grösser ist als der Abstand zwischen den Pupillen der Augen des Trägers.

8. Vorrichtung nach einem der vorhergehenden Ansprüche, dadurch gekennzeichnet, dass das Linsensystem ein Amici-Prisma (50), ein Objektiv (16), ein Pentaprisma (51) und ein Okular (17) in dieser Reihenfolge im Strahlengang vom Lichteintritt (13) zum Lichtaustritt (14) angeordnet enthält.

#### Revendications

1. Appareil facilitant la vision comprenant un long boîtier (12) contenant un système de lentilles et un dispositif de montage (43, 44) pour monter le boîtier (12) sur la tête d'un porteur de telle sorte que la longueur du boîtier (12) s'étende en substance horizontalement entre les tempes du porteur, caractérisé en ce qu'un système télescopique prismatique unique comprenant un objectif (16), un oculaire (17) et un dispositif optique inverseur et redresseur (50, 51; 52, 53; 56, 58) est prévu dans le boîtier, l'objectif (16) est monté dans le boîtier de telle sorte que la majeure partie de la distance focale de l'objectif (16) s'étende en substance parallèlement à l'axe longitudinal du boîtier et une seule sortie de lumière (14) est placée près d'un oeil du porteur.

2. Appareil suivant la revendication 1, caracté-

risé en ce qu'un dispositif de réglage (22) accessible de l'extérieur du boîtier (12) est présent pour régler la mise au point du système de lentilles.

3. Appareil suivant la revendication 2, caractérisé en ce que le dispositif de réglage comprend un organe d'actionnement tournant (22) qui s'étend dans le boîtier (12) et qui est relié à un bloc (30) portant l'objectif (16), la rotation de l'organe d'actionnement (22) ayant pour effet de déplacer l'objectif (16) dans le sens longitudinal du boîtier (12).

4. Appareil suivant les revendications 1, 2 ou 3, caractérisé en ce que le dispositif de montage comprend une monture de lunettes (40) et le boîtier (12) est monté sur la monture (40) ou est incorporé à la partie supérieure de celle-ci, l'entrée de lumière (13) étant orientée vers l'avant et la sortie de lumière (14) vers l'arrière par rapport à la tête du porteur.

5. Appareil suivant la revendication 4, caractérisé en ce que le boîtier (12) est monté sur la monture (40) de telle sorte que le porteur puisse voir

par la sortie de lumière (14) en inclinant son oeil vers le haut d'un angle d'environ 10°.

6. Appareil suivant la revendication 4 ou 5, caractérisé en ce que la largeur du boîtier (12) est telle que ce boîtier (12) ne fasse pas saillie vers l'avant d'une distance significative à partir de la monture de lunettes.

7. Appareil suivant l'une quelconque des revendications précédentes, caractérisé en ce que la longueur (L) du boîtier (12) est en substance égale à la distance entre les tempes du porteur et l'entrée de lumière (13) ainsi que la sortie de lumière (14) sont espacées l'une de l'autre d'une distance supérieure à la distance séparant les pupilles des yeux du porteur.

8. Appareil suivant l'une quelconque des revendications précédentes, caractérisé en ce que le système de lentilles comprend, montés dans l'ordre dans le trajet optique de l'entrée de lumière (13) vers la sortie de lumière (14), un prisme Amici (50), un objectif (16), un prisme pentagonal (51) et un oculaire (17).

25

30

35

40

45

50

55

60

65

6

Fig. 2

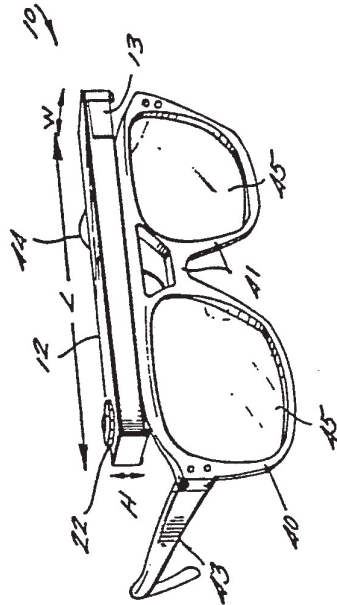

Fig. 1

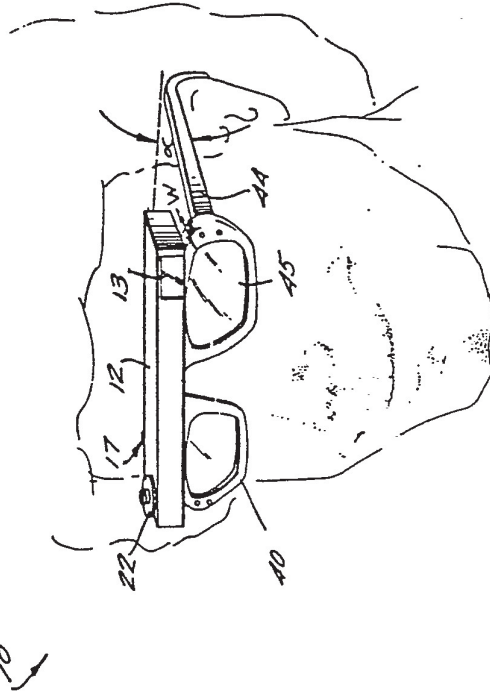

Fig. 3

